

# Chapter 11

## REFRIGERATION CYCLES

### The Reversed Carnot Cycle

**11-1C** Because the compression process involves the compression of a liquid-vapor mixture which requires a compressor that will handle two phases, and the expansion process involves the expansion of high-moisture content refrigerant.

**11-2** A steady-flow Carnot refrigeration cycle with refrigerant-134a as the working fluid is considered. The coefficient of performance, the amount of heat absorbed from the refrigerated space, and the net work input are to be determined.

**Assumptions** 1 Steady operating conditions exist. 2 Kinetic and potential energy changes are negligible.

**Analysis** (a) Noting that  $T_H = 30^\circ\text{C} = 303\text{ K}$  and  $T_L = T_{\text{sat @ } 160\text{ kPa}} = -15.60^\circ\text{C} = 257.4\text{ K}$ , the COP of this Carnot refrigerator is determined from

$$\text{COP}_{\text{R,C}} = \frac{1}{T_H / T_L - 1} = \frac{1}{(303\text{ K}) / (257.4\text{ K}) - 1} = \mathbf{5.64}$$

(b) From the refrigerant tables (Table A-11),

$$h_3 = h_g @ 30^\circ\text{C} = 266.66\text{ kJ/kg}$$

$$h_4 = h_f @ 30^\circ\text{C} = 93.58\text{ kJ/kg}$$

Thus,

$$q_H = h_3 - h_4 = 266.66 - 93.58 = 173.08\text{ kJ/kg}$$

and

$$\frac{q_H}{q_L} = \frac{T_H}{T_L} \longrightarrow q_L = \frac{T_L}{T_H} q_H = \left( \frac{257.4\text{ K}}{303\text{ K}} \right) (173.08\text{ kJ/kg}) = \mathbf{147.03\text{ kJ/kg}}$$

(c) The net work input is determined from

$$w_{\text{net}} = q_H - q_L = 173.08 - 147.03 = \mathbf{26.05\text{ kJ/kg}}$$

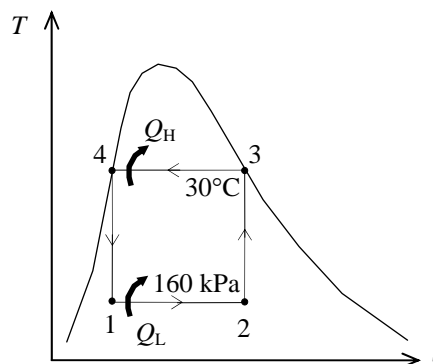

**11-3E** A steady-flow Carnot refrigeration cycle with refrigerant-134a as the working fluid is considered. The coefficient of performance, the quality at the beginning of the heat-absorption process, and the net work input are to be determined.

**Assumptions** 1 Steady operating conditions exist. 2 Kinetic and potential energy changes are negligible.

**Analysis** (a) Noting that  $T_H = T_{\text{sat}} @ 90 \text{ psia} = 72.78^\circ\text{F} = 532.8 \text{ R}$  and  $T_L = T_{\text{sat}} @ 30 \text{ psia} = 15.37^\circ\text{F} = 475.4 \text{ R}$ .

$$\text{COP}_{R,C} = \frac{1}{T_H / T_L - 1} = \frac{1}{(532.8 \text{ R}) / (475.4 \text{ R}) - 1} = \mathbf{8.28}$$

(b) Process 4-1 is isentropic, and thus

$$s_1 = s_4 = (s_f + x_4 s_{fg}) @ 90 \text{ psia} = 0.07481 + (0.05)(0.14525) \\ = 0.08207 \text{ Btu/lbm} \cdot \text{R}$$

$$x_1 = \left( \frac{s_1 - s_f}{s_{fg}} \right) @ 30 \text{ psia} = \frac{0.08207 - 0.03793}{0.18589} = \mathbf{0.2374}$$

(c) Remembering that on a  $T$ - $s$  diagram the area enclosed represents the net work, and  $s_3 = s_g @ 90 \text{ psia} = 0.22006 \text{ Btu/lbm} \cdot \text{R}$ ,

$$w_{\text{net,in}} = (T_H - T_L)(s_3 - s_4) = (72.78 - 15.37)(0.22006 - 0.08207) \text{ Btu/lbm} \cdot \text{R} = \mathbf{7.92 \text{ Btu/lbm}}$$

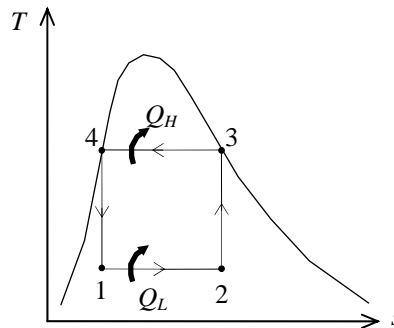

## Ideal and Actual Vapor-Compression Cycles

**11-4C** Yes; the throttling process is an internally irreversible process.

**11-5C** To make the ideal vapor-compression refrigeration cycle more closely approximate the actual cycle.

**11-6C** No. Assuming the water is maintained at 10°C in the evaporator, the evaporator pressure will be the saturation pressure corresponding to this pressure, which is 1.2 kPa. It is not practical to design refrigeration or air-conditioning devices that involve such extremely low pressures.

**11-7C** Allowing a temperature difference of 10°C for effective heat transfer, the condensation temperature of the refrigerant should be 25°C. The saturation pressure corresponding to 25°C is 0.67 MPa. Therefore, the recommended pressure would be 0.7 MPa.

**11-8C** The area enclosed by the cyclic curve on a  $T$ - $s$  diagram represents the net work input for the reversed Carnot cycle, but not so for the ideal vapor-compression refrigeration cycle. This is because the latter cycle involves an irreversible process for which the process path is not known.

**11-9C** The cycle that involves saturated liquid at 30°C will have a higher COP because, judging from the  $T$ - $s$  diagram, it will require a smaller work input for the same refrigeration capacity.

**11-10C** The minimum temperature that the refrigerant can be cooled to before throttling is the temperature of the sink (the cooling medium) since heat is transferred from the refrigerant to the cooling medium.

**11-11** A commercial refrigerator with refrigerant-134a as the working fluid is considered. The quality of the refrigerant at the evaporator inlet, the refrigeration load, the COP of the refrigerator, and the theoretical maximum refrigeration load for the same power input to the compressor are to be determined.

**Assumptions** 1 Steady operating conditions exist. 2 Kinetic and potential energy changes are negligible.

**Analysis** (a) From refrigerant-134a tables (Tables A-11 through A-13)

$$\left. \begin{array}{l} P_1 = 60 \text{ kPa} \\ T_1 = -34^\circ\text{C} \end{array} \right\} h_1 = 230.03 \text{ kJ/kg}$$

$$\left. \begin{array}{l} P_2 = 1200 \text{ kPa} \\ T_2 = 65^\circ\text{C} \end{array} \right\} h_2 = 295.16 \text{ kJ/kg}$$

$$\left. \begin{array}{l} P_3 = 1200 \text{ kPa} \\ T_3 = 42^\circ\text{C} \end{array} \right\} h_3 = 111.23 \text{ kJ/kg}$$

$$h_4 = h_3 = 111.23 \text{ kJ/kg}$$

$$\left. \begin{array}{l} P_4 = 60 \text{ kPa} \\ h_4 = 111.23 \text{ kJ/kg} \end{array} \right\} x_4 = \mathbf{0.4795}$$

Using saturated liquid enthalpy at the given temperature, for water we have (Table A-4)

$$h_{w1} = h_f @ 18^\circ\text{C} = 75.47 \text{ kJ/kg}$$

$$h_{w2} = h_f @ 26^\circ\text{C} = 108.94 \text{ kJ/kg}$$

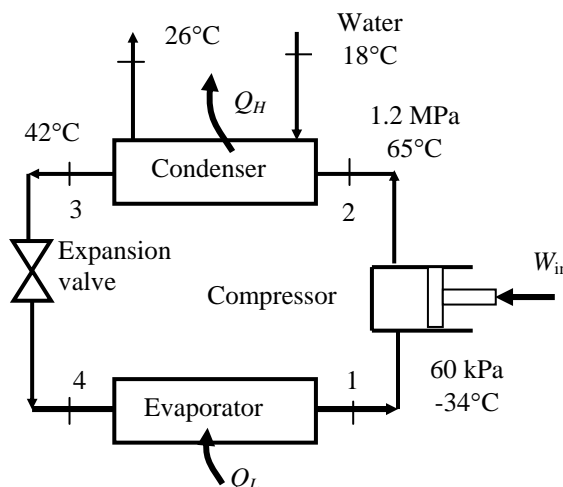

(b) The mass flow rate of the refrigerant may be determined from an energy balance on the compressor

$$\dot{m}_R(h_2 - h_3) = \dot{m}_w(h_{w2} - h_{w1})$$

$$\dot{m}_R(295.16 - 111.23) \text{ kJ/kg} = (0.25 \text{ kg/s})(108.94 - 75.47) \text{ kJ/kg}$$

$$\longrightarrow \dot{m}_R = 0.0455 \text{ kg/s}$$

The waste heat transferred from the refrigerant, the compressor power input, and the refrigeration load are

$$\dot{Q}_H = \dot{m}_R(h_2 - h_3) = (0.0455 \text{ kg/s})(295.16 - 111.23) \text{ kJ/kg} = 8.367 \text{ kW}$$

$$\dot{W}_{\text{in}} = \dot{m}_R(h_2 - h_1) - \dot{Q}_{\text{in}} = (0.0455 \text{ kg/s})(295.16 - 230.03) \text{ kJ/kg} - 0.45 \text{ kW} = 2.513 \text{ kW}$$

$$\dot{Q}_L = \dot{Q}_H - \dot{W}_{\text{in}} = 8.367 - 2.513 = \mathbf{5.85 \text{ kW}}$$

(c) The COP of the refrigerator is determined from its definition

$$\text{COP} = \frac{\dot{Q}_L}{\dot{W}_{\text{in}}} = \frac{5.85}{2.513} = \mathbf{2.33}$$

(d) The reversible COP of the refrigerator for the same temperature limits is

$$\text{COP}_{\text{max}} = \frac{1}{T_H/T_L - 1} = \frac{1}{(18 + 273)/(-30 + 273) - 1} = 5.063$$

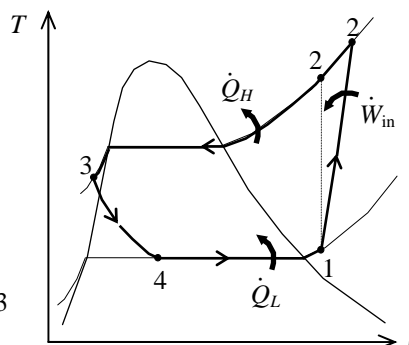

Then, the maximum refrigeration load becomes

$$\dot{Q}_{L,\text{max}} = \text{COP}_{\text{max}} \dot{W}_{\text{in}} = (5.063)(2.513 \text{ kW}) = \mathbf{12.72 \text{ kW}}$$

**11-12** An ideal vapor-compression refrigeration cycle with refrigerant-134a as the working fluid is considered. The COP and the power requirement are to be determined.

**Assumptions** 1 Steady operating conditions exist. 2 Kinetic and potential energy changes are negligible.

**Analysis** In an ideal vapor-compression refrigeration cycle, the compression process is isentropic, the refrigerant enters the compressor as a saturated vapor at the evaporator pressure, and leaves the condenser as saturated liquid at the condenser pressure. From the refrigerant tables (Tables A-11, A-12, and A-13),

$$\left. \begin{array}{l} T_1 = 4^\circ\text{C} \\ \text{sat. vapor} \end{array} \right\} \begin{array}{l} h_1 = h_g @ 4^\circ\text{C} = 252.77 \text{ kJ/kg} \\ s_1 = s_g @ 4^\circ\text{C} = 0.92927 \text{ kJ/kg}\cdot\text{K} \end{array}$$

$$\left. \begin{array}{l} P_2 = 1 \text{ MPa} \\ s_2 = s_1 \end{array} \right\} h_2 = 275.29 \text{ kJ/kg}$$

$$\left. \begin{array}{l} P_3 = 1 \text{ MPa} \\ \text{sat. liquid} \end{array} \right\} h_3 = h_f @ 1 \text{ MPa} = 107.32 \text{ kJ/kg}$$

$$h_4 \cong h_3 = 107.32 \text{ kJ/kg} \quad (\text{throttling})$$

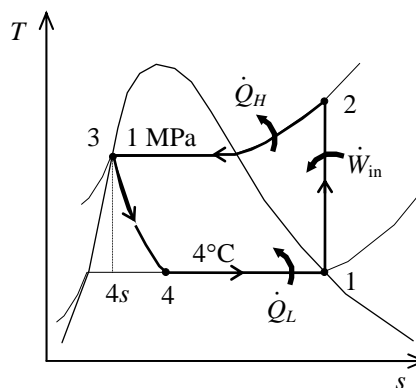

The mass flow rate of the refrigerant is

$$\dot{Q}_L = \dot{m}(h_1 - h_4) \longrightarrow \dot{m} = \frac{\dot{Q}_L}{h_1 - h_4} = \frac{400 \text{ kJ/s}}{(252.77 - 107.32) \text{ kJ/kg}} = 2.750 \text{ kg/s}$$

The power requirement is

$$\dot{W}_{\text{in}} = \dot{m}(h_2 - h_1) = (2.750 \text{ kg/s})(275.29 - 252.77) \text{ kJ/kg} = \mathbf{61.93 \text{ kW}}$$

The COP of the refrigerator is determined from its definition,

$$\text{COP}_R = \frac{\dot{Q}_L}{\dot{W}_{\text{in}}} = \frac{400 \text{ kW}}{61.93 \text{ kW}} = \mathbf{6.46}$$

**11-13** An ideal vapor-compression refrigeration cycle with refrigerant-134a as the working fluid is considered. The mass flow rate of the refrigerant and the power requirement are to be determined.

**Assumptions 1** Steady operating conditions exist. **2** Kinetic and potential energy changes are negligible.

**Analysis** In an ideal vapor-compression refrigeration cycle, the compression process is isentropic, the refrigerant enters the compressor as a saturated vapor at the evaporator pressure, and leaves the condenser as saturated liquid at the condenser pressure. From the refrigerant tables (Tables A-11, A-12, and A-13),

$$\left. \begin{array}{l} P_1 = 400 \text{ kPa} \\ \text{sat. vapor} \end{array} \right\} \begin{array}{l} h_1 = h_g @ 400 \text{ kPa} = 255.55 \text{ kJ/kg} \\ s_1 = s_g @ 400 \text{ kPa} = 0.92691 \text{ kJ/kg} \cdot \text{K} \end{array}$$

$$\left. \begin{array}{l} P_2 = 800 \text{ kPa} \\ s_2 = s_1 \end{array} \right\} h_2 = 269.90 \text{ kJ/kg}$$

$$\left. \begin{array}{l} P_3 = 800 \text{ kPa} \\ \text{sat. liquid} \end{array} \right\} h_3 = h_f @ 800 \text{ kPa} = 95.47 \text{ kJ/kg}$$

$$h_4 \cong h_3 = 95.47 \text{ kJ/kg} \quad (\text{throttling})$$

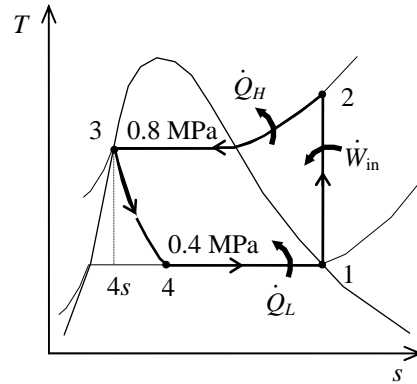

The mass flow rate of the refrigerant is determined from

$$\dot{Q}_L = \dot{m}(h_1 - h_4) \longrightarrow \dot{m} = \frac{\dot{Q}_L}{h_1 - h_4} = \frac{10 \text{ kJ/s}}{(255.55 - 95.47) \text{ kJ/kg}} = \mathbf{0.06247 \text{ kg/s}}$$

The power requirement is

$$\dot{W}_{\text{in}} = \dot{m}(h_2 - h_1) = (0.06247 \text{ kg/s})(269.90 - 255.55) \text{ kJ/kg} = \mathbf{0.8964 \text{ kW}}$$

**11-14E** An ideal vapor-compression refrigeration cycle with refrigerant-134a as the working fluid is considered. The mass flow rate of the refrigerant and the power requirement are to be determined.

**Assumptions 1** Steady operating conditions exist. **2** Kinetic and potential energy changes are negligible.

**Analysis** In an ideal vapor-compression refrigeration cycle, the compression process is isentropic, the refrigerant enters the compressor as a saturated vapor at the evaporator pressure, and leaves the condenser as saturated liquid at the condenser pressure. From the refrigerant tables (Tables A-11E, A-12E, and A-13E),

$$\left. \begin{array}{l} T_1 = -10^\circ\text{F} \\ \text{sat. vapor} \end{array} \right\} \begin{array}{l} h_1 = h_g @ -10^\circ\text{F} = 101.61 \text{ Btu/lbm} \\ s_1 = s_g @ -10^\circ\text{F} = 0.22660 \text{ Btu/lbm} \cdot \text{R} \end{array}$$

$$\left. \begin{array}{l} P_2 = 100 \text{ psia} \\ s_2 = s_1 \end{array} \right\} h_2 = 117.57 \text{ Btu/lbm}$$

$$\left. \begin{array}{l} P_3 = 100 \text{ psia} \\ \text{sat. liquid} \end{array} \right\} h_3 = h_f @ 100 \text{ psia} = 37.869 \text{ Btu/lbm}$$

$$h_4 \cong h_3 = 37.869 \text{ Btu/lbm} \quad (\text{throttling})$$

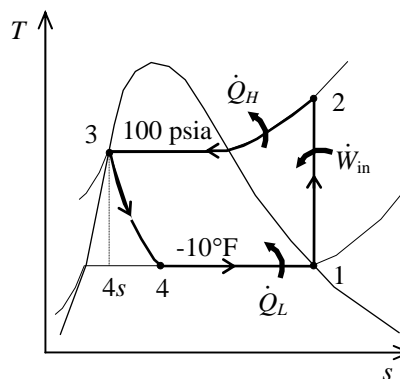

The mass flow rate of the refrigerant is

$$\dot{Q}_L = \dot{m}(h_1 - h_4) \longrightarrow \dot{m} = \frac{\dot{Q}_L}{h_1 - h_4} = \frac{24,000 \text{ Btu/h}}{(101.61 - 37.869) \text{ Btu/lbm}} = \mathbf{376.5 \text{ lbm/h}}$$

The power requirement is

$$\dot{W}_{\text{in}} = \dot{m}(h_2 - h_1) = (376.5 \text{ lbm/h})(117.57 - 101.61) \text{ Btu/lbm} \left( \frac{1 \text{ kW}}{3412.14 \text{ Btu/h}} \right) = \mathbf{1.761 \text{ kW}}$$

**11-15E** Problem 11-14E is to be repeated if ammonia is used as the refrigerant.

**Analysis** The problem is solved using EES, and the solution is given below.

"Given"

x[1]=1  
T[1]=-10 [F]  
x[3]=0  
P[3]=100 [psia]  
Q\_dot\_L=24000 [Btu/h]

"Analysis"

Fluid\$='ammonia'  
"compressor"  
h[1]=enthalpy(Fluid\$, T=T[1], x=x[1])  
s[1]=entropy(Fluid\$, T=T[1], x=x[1])  
s[2]=s[1]  
P[2]=P[3]  
h[2]=enthalpy(Fluid\$, P=P[2], s=s[2])  
"expansion valve"  
h[3]=enthalpy(Fluid\$, P=P[3], x=x[3])  
h[4]=h[3]  
"cycle"  
m\_dot\_R=Q\_dot\_L/(h[1]-h[4])  
W\_dot\_in=m\_dot\_R\*(h[2]-h[1])\*Convert(Btu/h, kW)

**Solution for ammonia**

Fluid\$='ammonia'  
h[2]=701.99 [Btu/lb\_m]  
**m\_dot\_R=47.69 [lbm/h]**  
Q\_dot\_L=24000 [Btu/h]  
T[1]=-10 [F]  
x[3]=0

**COP\_R=5.847**  
h[3]=112.67 [Btu/lb\_m]  
P[2]=100 [psia]  
s[1]=1.42220 [Btu/lb\_m-R]  
**W\_dot\_in=1.203 [kW]**

h[1]=615.92 [Btu/lb\_m]  
h[4]=112.67 [Btu/lb\_m]  
P[3]=100 [psia]  
s[2]=1.42220 [Btu/lb\_m-R]  
x[1]=1

**Solution for R-134a**

Fluid\$='R134a'  
h[2]=117.58 [Btu/lb\_m]  
**m\_dot\_R=376.5 [lbm/h]**  
Q\_dot\_L=24000 [Btu/h]  
T[1]=-10 [F]  
x[3]=0

**COP\_R=3.993**  
h[3]=37.87 [Btu/lb\_m]  
P[2]=100 [psia]  
s[1]=0.22662 [Btu/lb\_m-R]  
**W\_dot\_in=1.761 [kW]**

h[1]=101.62 [Btu/lb\_m]  
h[4]=37.87 [Btu/lb\_m]  
P[3]=100 [psia]  
s[2]=0.22662 [Btu/lb\_m-R]  
x[1]=1



**11-16** An ideal vapor-compression refrigeration cycle with refrigerant-134a as the working fluid is considered. The rate of heat removal from the refrigerated space, the power input to the compressor, the rate of heat rejection to the environment, and the COP are to be determined.

**Assumptions** 1 Steady operating conditions exist. 2 Kinetic and potential energy changes are negligible.

**Analysis** (a) In an ideal vapor-compression refrigeration cycle, the compression process is isentropic, the refrigerant enters the compressor as a saturated vapor at the evaporator pressure, and leaves the condenser as saturated liquid at the condenser pressure. From the refrigerant tables (Tables A-12 and A-13),

$$\left. \begin{array}{l} P_1 = 120 \text{ kPa} \\ \text{sat. vapor} \end{array} \right\} \begin{array}{l} h_1 = h_g @ 120 \text{ kPa} = 236.97 \text{ kJ/kg} \\ s_1 = s_g @ 120 \text{ kPa} = 0.94779 \text{ kJ/kg} \cdot \text{K} \end{array}$$

$$\left. \begin{array}{l} P_2 = 0.7 \text{ MPa} \\ s_2 = s_1 \end{array} \right\} \begin{array}{l} h_2 = 273.50 \text{ kJ/kg} \quad (T_2 = 34.95^\circ\text{C}) \end{array}$$

$$\left. \begin{array}{l} P_3 = 0.7 \text{ MPa} \\ \text{sat. liquid} \end{array} \right\} h_3 = h_f @ 0.7 \text{ MPa} = 88.82 \text{ kJ/kg}$$

$$h_4 \cong h_3 = 88.82 \text{ kJ/kg} \quad (\text{throttling})$$

Then the rate of heat removal from the refrigerated space and the power input to the compressor are determined from

$$\dot{Q}_L = \dot{m}(h_1 - h_4) = (0.05 \text{ kg/s})(236.97 - 88.82) \text{ kJ/kg} = \mathbf{7.41 \text{ kW}}$$

and

$$\dot{W}_{\text{in}} = \dot{m}(h_2 - h_1) = (0.05 \text{ kg/s})(273.50 - 236.97) \text{ kJ/kg} = \mathbf{1.83 \text{ kW}}$$

(b) The rate of heat rejection to the environment is determined from

$$\dot{Q}_H = \dot{Q}_L + \dot{W}_{\text{in}} = 7.41 + 1.83 = \mathbf{9.23 \text{ kW}}$$

(c) The COP of the refrigerator is determined from its definition,

$$\text{COP}_R = \frac{\dot{Q}_L}{\dot{W}_{\text{in}}} = \frac{7.41 \text{ kW}}{1.83 \text{ kW}} = \mathbf{4.06}$$

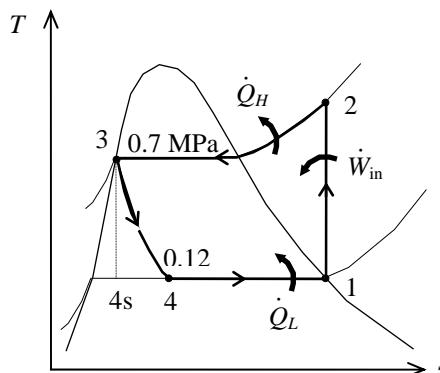

**11-17** An ideal vapor-compression refrigeration cycle with refrigerant-134a as the working fluid is considered. The rate of heat removal from the refrigerated space, the power input to the compressor, the rate of heat rejection to the environment, and the COP are to be determined.

**Assumptions** 1 Steady operating conditions exist. 2 Kinetic and potential energy changes are negligible.

**Analysis** (a) In an ideal vapor-compression refrigeration cycle, the compression process is isentropic, the refrigerant enters the compressor as a saturated vapor at the evaporator pressure, and leaves the condenser as saturated liquid at the condenser pressure. From the refrigerant tables (Tables A-12 and A-13),

$$P_1 = 120 \text{ kPa} \left\{ \begin{array}{l} h_1 = h_g @ 120 \text{ kPa} = 236.97 \text{ kJ/kg} \\ \text{sat. vapor} \quad \left. \begin{array}{l} s_1 = s_g @ 120 \text{ kPa} = 0.94779 \text{ kJ/kg} \cdot \text{K} \end{array} \right\} \end{array} \right.$$

$$P_2 = 0.9 \text{ MPa} \left\{ \begin{array}{l} h_2 = 278.93 \text{ kJ/kg} \quad (T_2 = 44.45^\circ\text{C}) \\ s_2 = s_1 \end{array} \right.$$

$$P_3 = 0.9 \text{ MPa} \left\{ \begin{array}{l} h_3 = h_f @ 0.9 \text{ MPa} = 101.61 \text{ kJ/kg} \\ \text{sat. liquid} \end{array} \right.$$

$$h_4 \cong h_3 = 101.61 \text{ kJ/kg} \quad (\text{throttling})$$

Then the rate of heat removal from the refrigerated space and the power input to the compressor are determined from

$$\dot{Q}_L = \dot{m}(h_1 - h_4) = (0.05 \text{ kg/s})(236.97 - 101.61) \text{ kJ/kg} = \mathbf{6.77 \text{ kW}}$$

and

$$\dot{W}_{\text{in}} = \dot{m}(h_2 - h_1) = (0.05 \text{ kg/s})(278.93 - 236.97) \text{ kJ/kg} = \mathbf{2.10 \text{ kW}}$$

(b) The rate of heat rejection to the environment is determined from

$$\dot{Q}_H = \dot{Q}_L + \dot{W}_{\text{in}} = 6.77 + 2.10 = \mathbf{8.87 \text{ kW}}$$

(c) The COP of the refrigerator is determined from its definition,

$$\text{COP}_R = \frac{\dot{Q}_L}{\dot{W}_{\text{in}}} = \frac{6.77 \text{ kW}}{2.10 \text{ kW}} = \mathbf{3.23}$$

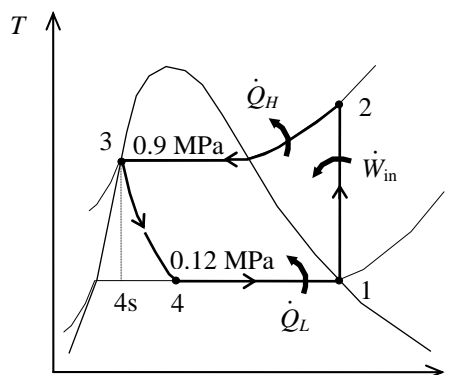

**11-18** An ideal vapor-compression refrigeration cycle with refrigerant-134a as the working fluid is considered. The throttling valve in the cycle is replaced by an isentropic turbine. The percentage increase in the COP and in the rate of heat removal from the refrigerated space due to this replacement are to be determined.

**Assumptions 1** Steady operating conditions exist.

**2** Kinetic and potential energy changes are negligible.

**Analysis** If the throttling valve in the previous problem is replaced by an isentropic turbine, we would have  $s_{4s} = s_3 = s_f @ 0.7 \text{ MPa} = 0.33230$  kJ/kg·K, and the enthalpy at the turbine exit would be

$$x_{4s} = \left( \frac{s_3 - s_f}{s_{fg}} \right)_{@ 120 \text{ kPa}} = \frac{0.33230 - 0.09275}{0.85503} = 0.2802$$

$$h_{4s} = (h_f + x_{4s}h_{fg})_{@ 120 \text{ kPa}} = 22.49 + (0.2802)(214.48) = 82.58 \text{ kJ/kg}$$

Then,

$$\dot{Q}_L = \dot{m}(h_1 - h_{4s}) = (0.05 \text{ kg/s})(236.97 - 82.58) \text{ kJ/kg} = 7.72 \text{ kW}$$

and

$$\text{COP}_R = \frac{\dot{Q}_L}{\dot{W}_{\text{in}}} = \frac{7.72 \text{ kW}}{1.83 \text{ kW}} = 4.23$$

Then the percentage increase in  $\dot{Q}$  and COP becomes

$$\text{Increase in } \dot{Q}_L = \frac{\Delta \dot{Q}_L}{\dot{Q}_L} = \frac{7.72 - 7.41}{7.41} = \mathbf{4.2\%}$$

$$\text{Increase in } \text{COP}_R = \frac{\Delta \text{COP}_R}{\text{COP}_R} = \frac{4.23 - 4.06}{4.06} = \mathbf{4.2\%}$$

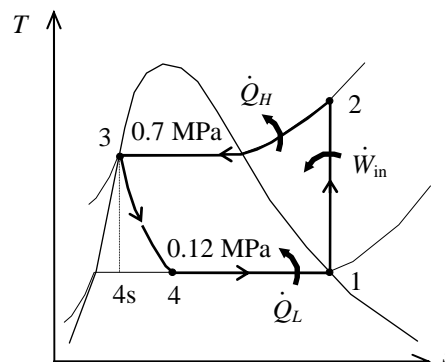

**11-19** A refrigerator with refrigerant-134a as the working fluid is considered. The rate of heat removal from the refrigerated space, the power input to the compressor, the isentropic efficiency of the compressor, and the COP of the refrigerator are to be determined.

**Assumptions** 1 Steady operating conditions exist. 2 Kinetic and potential energy changes are negligible.

**Analysis** (a) From the refrigerant tables (Tables A-12 and A-13),

$$\left. \begin{array}{l} P_1 = 0.14 \text{ MPa} \\ T_1 = -10^\circ\text{C} \end{array} \right\} \begin{array}{l} h_1 = 246.36 \text{ kJ/kg} \\ s_1 = 0.97236 \text{ kJ/kg} \cdot \text{K} \end{array}$$

$$\left. \begin{array}{l} P_2 = 0.7 \text{ MPa} \\ T_2 = 50^\circ\text{C} \end{array} \right\} h_2 = 288.53 \text{ kJ/kg}$$

$$\left. \begin{array}{l} P_{2s} = 0.7 \text{ MPa} \\ s_{2s} = s_1 \end{array} \right\} h_{2s} = 281.16 \text{ kJ/kg}$$

$$\left. \begin{array}{l} P_3 = 0.65 \text{ MPa} \\ T_3 = 24^\circ\text{C} \end{array} \right\} h_3 = h_f @ 24^\circ\text{C} = 84.98 \text{ kJ/kg}$$

$$h_4 \cong h_3 = 84.98 \text{ kJ/kg (throttling)}$$

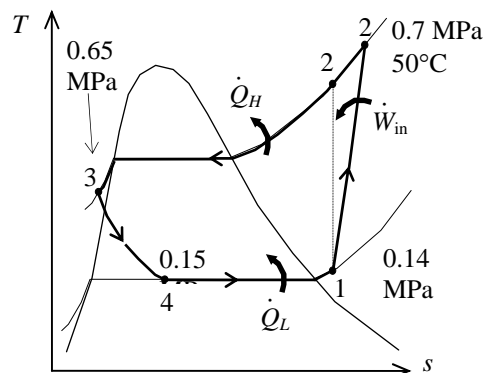

Then the rate of heat removal from the refrigerated space and the power input to the compressor are determined from

$$\dot{Q}_L = \dot{m}(h_1 - h_4) = (0.12 \text{ kg/s})(246.36 - 84.98) \text{ kJ/kg} = \mathbf{19.4 \text{ kW}}$$

and

$$\dot{W}_{\text{in}} = \dot{m}(h_2 - h_1) = (0.12 \text{ kg/s})(288.53 - 246.36) \text{ kJ/kg} = \mathbf{5.06 \text{ kW}}$$

(b) The adiabatic efficiency of the compressor is determined from

$$\eta_C = \frac{h_{2s} - h_1}{h_2 - h_1} = \frac{281.16 - 246.36}{288.53 - 246.36} = \mathbf{82.5\%}$$

(c) The COP of the refrigerator is determined from its definition,

$$\text{COP}_R = \frac{\dot{Q}_L}{\dot{W}_{\text{in}}} = \frac{19.4 \text{ kW}}{5.06 \text{ kW}} = \mathbf{3.83}$$

**11-20** An air conditioner operating on the ideal vapor-compression refrigeration cycle with refrigerant-134a as the working fluid is considered. The COP of the system is to be determined.

**Assumptions** 1 Steady operating conditions exist. 2 Kinetic and potential energy changes are negligible.

**Analysis** In an ideal vapor-compression refrigeration cycle, the compression process is isentropic, the refrigerant enters the compressor as a saturated vapor at the evaporator pressure, and leaves the condenser as saturated liquid at the condenser pressure. The evaporating temperature will be  $22-2=20^\circ\text{C}$ . From the refrigerant tables (Tables A-11, A-12, and A-13),

$$\left. \begin{array}{l} T_1 = 20^\circ\text{C} \\ \text{sat. vapor} \end{array} \right\} \begin{array}{l} h_1 = h_g @ 20^\circ\text{C} = 261.59 \text{ kJ/kg} \\ s_1 = s_g @ 20^\circ\text{C} = 0.92234 \text{ kJ/kg}\cdot\text{K} \end{array}$$

$$\left. \begin{array}{l} P_2 = 1 \text{ MPa} \\ s_2 = s_1 \end{array} \right\} h_2 = 273.11 \text{ kJ/kg}$$

$$\left. \begin{array}{l} P_3 = 1 \text{ MPa} \\ \text{sat. liquid} \end{array} \right\} h_3 = h_f @ 1 \text{ MPa} = 107.32 \text{ kJ/kg}$$

$$h_4 \cong h_3 = 107.32 \text{ kJ/kg} \quad (\text{throttling})$$

The COP of the air conditioner is determined from its definition,

$$\text{COP}_{\text{AC}} = \frac{q_L}{w_{\text{in}}} = \frac{h_1 - h_4}{h_2 - h_1} = \frac{261.59 - 107.32}{273.11 - 261.59} = \mathbf{13.39}$$

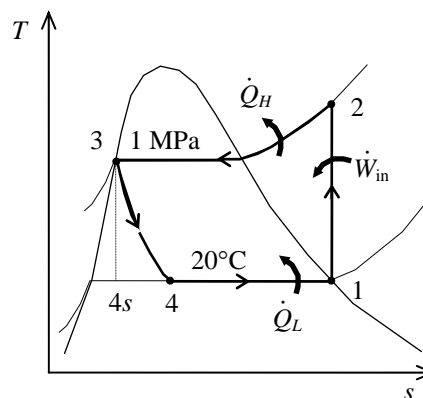

**11-21E** A refrigerator operating on the ideal vapor-compression refrigeration cycle with refrigerant-134a as the working fluid is considered. The increase in the COP if the throttling process were replaced by an isentropic expansion is to be determined.

**Assumptions** 1 Steady operating conditions exist. 2 Kinetic and potential energy changes are negligible.

**Analysis** In an ideal vapor-compression refrigeration cycle, the compression process is isentropic, the refrigerant enters the compressor as a saturated vapor at the evaporator pressure, and leaves the condenser as saturated liquid at the condenser pressure. From the refrigerant tables (Tables A-11E, A-12E, and A-13E),

$$\left. \begin{array}{l} T_1 = 20^\circ\text{F} \\ \text{sat. vapor} \end{array} \right\} \begin{array}{l} h_1 = h_g @ 20^\circ\text{F} = 105.98 \text{ Btu/lbm} \\ s_1 = s_g @ 20^\circ\text{F} = 0.22341 \text{ Btu/lbm} \cdot \text{R} \end{array}$$

$$\left. \begin{array}{l} P_2 = 300 \text{ psia} \\ s_2 = s_1 \end{array} \right\} h_2 = 125.68 \text{ Btu/lbm}$$

$$\left. \begin{array}{l} P_3 = 300 \text{ psia} \\ \text{sat. liquid} \end{array} \right\} \begin{array}{l} h_3 = h_f @ 300 \text{ psia} = 66.339 \text{ Btu/lbm} \\ s_3 = s_f @ 300 \text{ psia} = 0.12715 \text{ Btu/lbm} \cdot \text{R} \end{array}$$

$$h_4 \cong h_3 = 66.339 \text{ Btu/lbm} \quad (\text{throttling})$$

$$\left. \begin{array}{l} T_4 = 15^\circ\text{F} \\ s_4 = s_3 \end{array} \right\} h_{4s} = 59.80 \text{ Btu/lbm} \quad (\text{isentropic expansion})$$

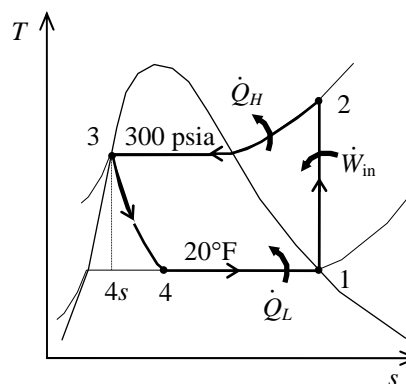

The COP of the refrigerator for the throttling case is

$$\text{COP}_R = \frac{q_L}{w_{\text{in}}} = \frac{h_1 - h_4}{h_2 - h_1} = \frac{105.98 - 66.339}{125.68 - 105.98} = \mathbf{2.012}$$

The COP of the refrigerator for the isentropic expansion case is

$$\text{COP}_R = \frac{q_L}{w_{\text{in}}} = \frac{h_1 - h_{4s}}{h_2 - h_1} = \frac{105.98 - 59.80}{125.68 - 105.98} = \mathbf{2.344}$$

The increase in the COP by isentropic expansion is **16.5%**.

**11-22** An ideal vapor-compression refrigeration cycle with refrigerant-134a as the working fluid is considered. The COP of the system and the cooling load are to be determined.

**Assumptions** 1 Steady operating conditions exist. 2 Kinetic and potential energy changes are negligible.

**Analysis** In an ideal vapor-compression refrigeration cycle, the compression process is isentropic, the refrigerant enters the compressor as a saturated vapor at the evaporator pressure, and leaves the condenser as saturated liquid at the condenser pressure. From the refrigerant tables (Tables A-11, A-12, and A-13),

$$\left. \begin{array}{l} T_1 = -10^\circ\text{C} \\ \text{sat. vapor} \end{array} \right\} \begin{array}{l} h_1 = h_g @ -10^\circ\text{C} = 244.51 \text{ kJ/kg} \\ s_1 = s_g @ -10^\circ\text{C} = 0.93766 \text{ kJ/kg}\cdot\text{K} \end{array}$$

$$\left. \begin{array}{l} P_2 = 600 \text{ kPa} \\ s_2 = s_1 \end{array} \right\} h_2 = 267.12 \text{ kJ/kg}$$

$$\left. \begin{array}{l} P_3 = 600 \text{ kPa} \\ \text{sat. liquid} \end{array} \right\} h_3 = h_f @ 600 \text{ kPa} = 81.51 \text{ kJ/kg}$$

$$h_4 \cong h_3 = 81.51 \text{ kJ/kg} \quad (\text{throttling})$$

The COP of the air conditioner is determined from its definition,

$$\text{COP}_{\text{AC}} = \frac{q_L}{w_{\text{in}}} = \frac{h_1 - h_4}{h_2 - h_1} = \frac{244.51 - 81.51}{267.12 - 244.51} = \mathbf{7.21}$$

The cooling load is

$$\dot{Q}_L = \dot{m}(h_1 - h_4) = (7 \text{ kg/s})(244.51 - 81.51) \text{ kJ/kg} = \mathbf{1141 \text{ kW}}$$

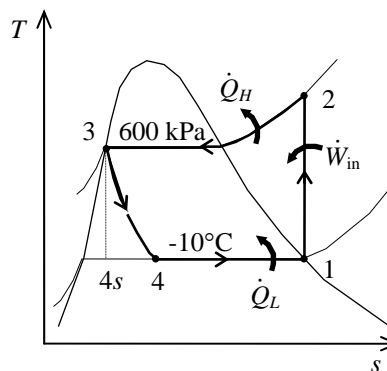

**11-23** A refrigerator with refrigerant-134a as the working fluid is considered. The power input to the compressor, the rate of heat removal from the refrigerated space, and the pressure drop and the rate of heat gain in the line between the evaporator and the compressor are to be determined.

**Assumptions** 1 Steady operating conditions exist. 2 Kinetic and potential energy changes are negligible.

**Analysis** (a) From the refrigerant tables (Tables A-12 and A-13),

$$\left. \begin{array}{l} P_1 = 140 \text{ kPa} \\ T_1 = -10^\circ\text{C} \end{array} \right\} \begin{array}{l} h_1 = 246.36 \text{ kJ/kg} \\ s_1 = 0.97236 \text{ kJ/kg} \cdot \text{K} \\ v_1 = 0.14605 \text{ m}^3/\text{kg} \end{array}$$

$$\left. \begin{array}{l} P_2 = 1.0 \text{ MPa} \\ s_{2s} = s_1 \end{array} \right\} \begin{array}{l} h_{2s} = 289.20 \text{ kJ/kg} \\ h_3 \cong h_f @ 30^\circ\text{C} = 93.58 \text{ kJ/kg} \end{array}$$

$$\left. \begin{array}{l} P_3 = 0.95 \text{ MPa} \\ T_3 = 30^\circ\text{C} \end{array} \right\} \begin{array}{l} h_3 \cong h_f @ 30^\circ\text{C} = 93.58 \text{ kJ/kg} \\ h_4 \cong h_3 = 93.58 \text{ kJ/kg (throttling)} \end{array}$$

$$\left. \begin{array}{l} T_5 = -18.5^\circ\text{C} \\ \text{sat. vapor} \end{array} \right\} \begin{array}{l} P_5 = 0.14165 \text{ MPa} \\ h_5 = 239.33 \text{ kJ/kg} \end{array}$$

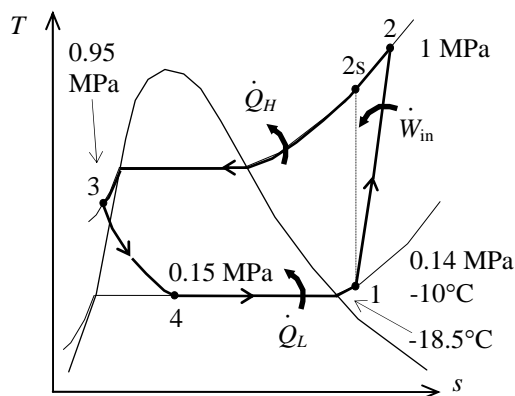

Then the mass flow rate of the refrigerant and the power input becomes

$$\dot{m} = \frac{\dot{V}_1}{v_1} = \frac{0.3/60 \text{ m}^3/\text{s}}{0.14605 \text{ m}^3/\text{kg}} = 0.03423 \text{ kg/s}$$

$$\dot{W}_{\text{in}} = \dot{m}(h_{2s} - h_1)/\eta_C = (0.03423 \text{ kg/s})[(289.20 - 246.36) \text{ kJ/kg}]/(0.78) = \mathbf{1.88 \text{ kW}}$$

(b) The rate of heat removal from the refrigerated space is

$$\dot{Q}_L = \dot{m}(h_5 - h_4) = (0.03423 \text{ kg/s})(239.33 - 93.58) \text{ kJ/kg} = \mathbf{4.99 \text{ kW}}$$

(c) The pressure drop and the heat gain in the line between the evaporator and the compressor are

$$\Delta P = P_5 - P_1 = 141.65 - 140 = \mathbf{1.65}$$

and

$$\dot{Q}_{\text{gain}} = \dot{m}(h_1 - h_5) = (0.03423 \text{ kg/s})(246.36 - 239.33) \text{ kJ/kg} = \mathbf{0.241 \text{ kW}}$$



**11-24 EES** Problem 11-23 is reconsidered. The effects of the compressor isentropic efficiency and the compressor inlet volume flow rate on the power input and the rate of refrigeration are to be investigated.

*Analysis* The problem is solved using EES, and the solution is given below.

"Input Data"

T[5]=-18.5 [C]  
 P[1]=140 [kPa]  
 T[1] = -10 [C]  
 V\_dot[1]=0.1 [m^3/min]  
 P[2] = 1000 [kPa]  
 P[3]=950 [kPa]  
 T[3] = 30 [C]  
 Eta\_c=0.78  
 Fluid\$='R134a'

"Compressor"

h[1]=enthalpy(Fluid\$,P=P[1],T=T[1]) "properties for state 1"  
 s[1]=entropy(Fluid\$,P=P[1],T=T[1])  
 v[1]=volume(Fluid\$,P=P[1],T=T[1])"[m^3/kg]"  
 m\_dot=V\_dot[1]/v[1]\*convert(m^3/min,m^3/s)"[kg/s]"  
 h2s=enthalpy(Fluid\$,P=P[2],s=s[1]) "Identifies state 2s as isentropic"  
 h[1]+Wcs=h2s "energy balance on isentropic compressor"

Wc=Wcs/Eta\_c"definition of compressor isentropic efficiency"  
 h[1]+Wc=h[2] "energy balance on real compressor-assumed adiabatic"  
 s[2]=entropy(Fluid\$,h=h[2],P=P[2]) "properties for state 2"  
 T[2]=temperature(Fluid\$,h=h[2],P=P[2])  
 W\_dot\_c=m\_dot\*Wc

"Condenser"

h[3]=enthalpy(Fluid\$,P=P[3],T=T[3]) "properties for state 3"  
 s[3]=entropy(Fluid\$,P=P[3],T=T[3])  
 h[2]=q\_out+h[3] "energy balance on condenser"  
 Q\_dot\_out=m\_dot\*q\_out

"Throttle Valve"

h[4]=h[3] "energy balance on throttle - isenthalpic"  
 x[4]=quality(Fluid\$,h=h[4],P=P[4]) "properties for state 4"  
 s[4]=entropy(Fluid\$,h=h[4],P=P[4])  
 T[4]=temperature(Fluid\$,h=h[4],P=P[4])

"Evaporator"

P[4]=pressure(Fluid\$,T=T[5],x=0)"pressure=Psat at evaporator exit temp."  
 P[5] = P[4]  
 h[5]=enthalpy(Fluid\$,T=T[5],x=1) "properties for state 5"

q\_in + h[4]=h[5] "energy balance on evaporator"  
 Q\_dot\_in=m\_dot\*q\_in  
 COP=Q\_dot\_in/W\_dot\_c "definition of COP"  
 COP\_plot = COP  
 W\_dot\_in = W\_dot\_c  
 Q\_dot\_line5to1=m\_dot\*(h[1]-h[5])"[kW]"

$COP_{plot}$	$W_{in}[kW]$	$Q_{in} [kW]$	$\eta_c$
2.041	0.8149	1.663	0.6
2.381	0.6985	1.663	0.7
2.721	0.6112	1.663	0.8
3.062	0.5433	1.663	0.9
3.402	0.4889	1.663	1

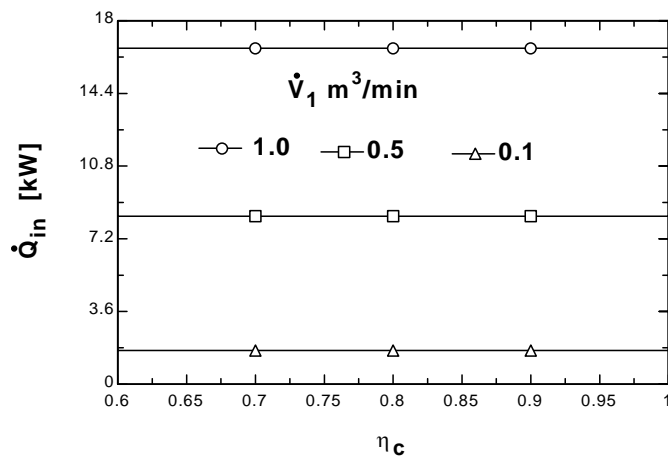
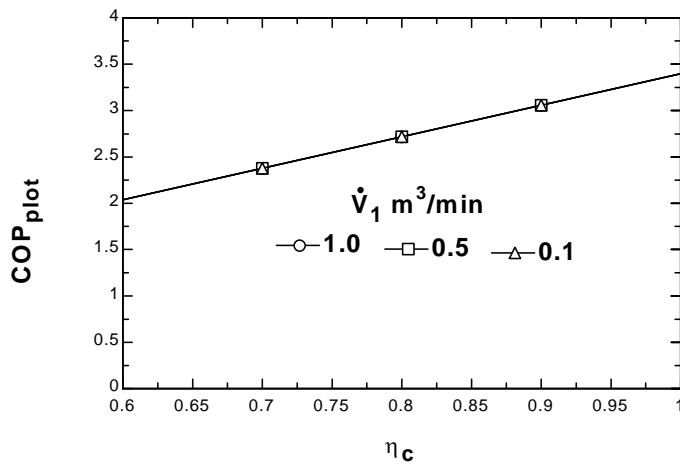
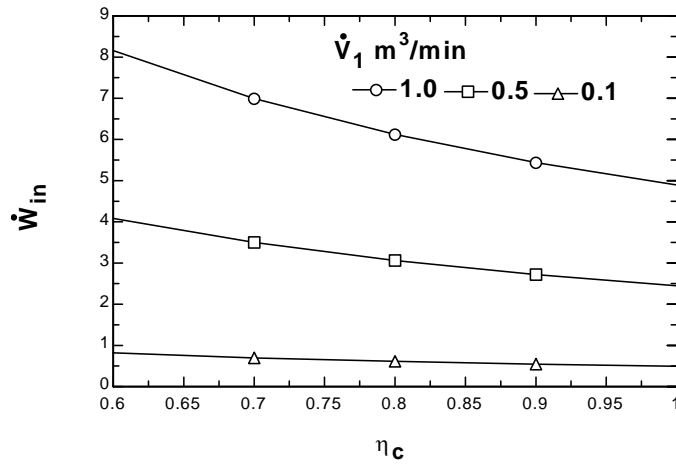

**11-25** A refrigerator uses refrigerant-134a as the working fluid and operates on the ideal vapor-compression refrigeration cycle. The mass flow rate of the refrigerant, the condenser pressure, and the COP of the refrigerator are to be determined.

**Assumptions** 1 Steady operating conditions exist. 2 Kinetic and potential energy changes are negligible.

**Analysis** (a) (b) From the refrigerant-134a tables (Tables A-11 through A-13)

$$\left. \begin{array}{l} P_4 = 120 \text{ kPa} \\ x_4 = 0.30 \end{array} \right\} h_4 = 86.83 \text{ kJ/kg}$$

$$h_3 = h_4$$

$$\left. \begin{array}{l} h_3 = 86.83 \text{ kJ/kg} \\ x_3 = 0 \text{ (sat. liq.)} \end{array} \right\} P_3 = \mathbf{671.8 \text{ kPa}}$$

$$P_2 = P_3$$

$$\left. \begin{array}{l} P_2 = 671.8 \text{ kPa} \\ T_2 = 60^\circ\text{C} \end{array} \right\} h_2 = 298.87 \text{ kJ/kg}$$

$$\left. \begin{array}{l} P_1 = P_4 = 120 \text{ kPa} \\ x_1 = 1 \text{ (sat. vap.)} \end{array} \right\} h_1 = 236.97 \text{ kJ/kg}$$

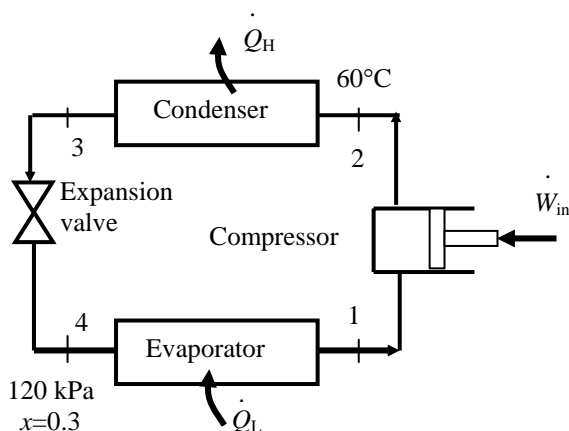

The mass flow rate of the refrigerant is determined from

$$\dot{m} = \frac{\dot{W}_{\text{in}}}{h_2 - h_1} = \frac{0.45 \text{ kW}}{(298.87 - 236.97) \text{ kJ/kg}} = \mathbf{0.00727 \text{ kg/s}}$$

(c) The refrigeration load and the COP are

$$\begin{aligned} \dot{Q}_L &= \dot{m}(h_1 - h_4) \\ &= (0.00727 \text{ kg/s})(236.97 - 86.83) \text{ kJ/kg} \\ &= \mathbf{1.091 \text{ kW}} \end{aligned}$$

$$\text{COP} = \frac{\dot{Q}_L}{\dot{W}_{\text{in}}} = \frac{1.091 \text{ kW}}{0.45 \text{ kW}} = \mathbf{2.43}$$

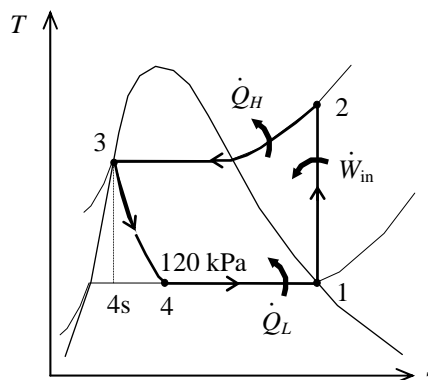

## Selecting the Right Refrigerant

**11-26C** The desirable characteristics of a refrigerant are to have an evaporator pressure which is above the atmospheric pressure, and a condenser pressure which corresponds to a saturation temperature above the temperature of the cooling medium. Other desirable characteristics of a refrigerant include being nontoxic, noncorrosive, nonflammable, chemically stable, having a high enthalpy of vaporization (minimizes the mass flow rate) and, of course, being available at low cost.

**11-27C** The minimum pressure that the refrigerant needs to be compressed to is the saturation pressure of the refrigerant at 30°C, which is **0.771 MPa**. At lower pressures, the refrigerant will have to condense at temperatures lower than the temperature of the surroundings, which cannot happen.

**11-28C** Allowing a temperature difference of 10°C for effective heat transfer, the evaporation temperature of the refrigerant should be -20°C. The saturation pressure corresponding to -20°C is 0.133 MPa. Therefore, the recommended pressure would be 0.12 MPa.

**11-29** A refrigerator that operates on the ideal vapor-compression cycle with refrigerant-134a is considered. Reasonable pressures for the evaporator and the condenser are to be selected.

**Assumptions** 1 Steady operating conditions exist. 2 Kinetic and potential energy changes are negligible.

**Analysis** Allowing a temperature difference of 10°C for effective heat transfer, the evaporation and condensation temperatures of the refrigerant should be -20°C and 35°C, respectively. The saturation pressures corresponding to these temperatures are 0.133 MPa and 0.888 MPa. Therefore, the recommended evaporator and condenser pressures are **0.133 MPa** and **0.888 MPa**, respectively.

**11-30** A heat pump that operates on the ideal vapor-compression cycle with refrigerant-134a is considered. Reasonable pressures for the evaporator and the condenser are to be selected.

**Assumptions** 1 Steady operating conditions exist. 2 Kinetic and potential energy changes are negligible.

**Analysis** Allowing a temperature difference of 10°C for effective heat transfer, the evaporation and condensation temperatures of the refrigerant should be 0°C and 32°C, respectively. The saturation pressures corresponding to these temperatures are 0.293 MPa and 0.816 MPa. Therefore, the recommended evaporator and condenser pressures are **0.293 MPa** and **0.816 MPa**, respectively.

## Heat Pump Systems

**11-31C** A heat pump system is more cost effective in Miami because of the low heating loads and high cooling loads at that location.

**11-32C** A water-source heat pump extracts heat from water instead of air. Water-source heat pumps have higher COPs than the air-source systems because the temperature of water is higher than the temperature of air in winter.

**11-33** An actual heat pump cycle with R-134a as the refrigerant is considered. The isentropic efficiency of the compressor, the rate of heat supplied to the heated room, the COP of the heat pump, and the COP of the heat pump and the rate of heat supplied to the heated room if this heat pump operated on the ideal vapor-compression cycle between the same pressure limits are to be determined.

**Assumptions** 1 Steady operating conditions exist. 2 Kinetic and potential energy changes are negligible.

**Analysis** (a) The properties of refrigerant-134a are (Tables A-11 through A-13)

$$\left. \begin{array}{l} P_2 = 800 \text{ kPa} \\ T_2 = 55^\circ\text{C} \end{array} \right\} h_2 = 291.76 \text{ kJ/kg}$$

$$T_3 = T_{\text{sat}@750 \text{ kPa}} = 29.06^\circ\text{C}$$

$$\left. \begin{array}{l} P_3 = 750 \text{ kPa} \\ T_3 = (29.06 - 3)^\circ\text{C} \end{array} \right\} h_3 = 87.91 \text{ kJ/kg}$$

$$h_4 = h_3 = 87.91 \text{ kJ/kg}$$

$$T_{\text{sat}@200 \text{ kPa}} = -10.09^\circ\text{C}$$

$$\left. \begin{array}{l} P_1 = 200 \text{ kPa} \\ T_1 = (-10.09 + 4)^\circ\text{C} \end{array} \right\} s_1 = 0.9506 \text{ kJ/kg}$$

$$\left. \begin{array}{l} P_2 = 800 \text{ kPa} \\ s_2 = s_1 \end{array} \right\} h_{2s} = 277.26$$

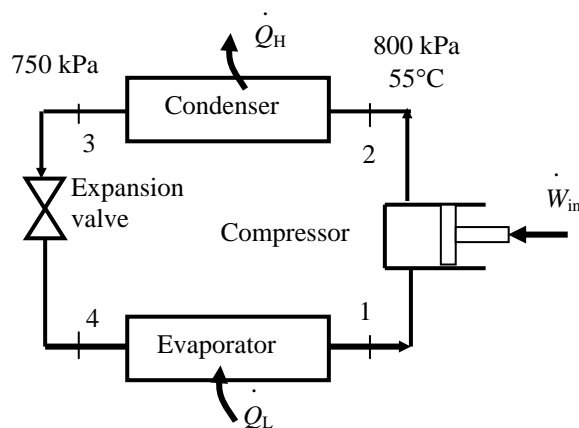

The isentropic efficiency of the compressor is

$$\eta_C = \frac{h_{2s} - h_1}{h_2 - h_1} = \frac{277.26 - 247.87}{291.76 - 247.87} = \mathbf{0.670}$$

(b) The rate of heat supplied to the room is

$$\dot{Q}_H = \dot{m}(h_2 - h_3) = (0.018 \text{ kg/s})(291.76 - 87.91) \text{ kJ/kg} = \mathbf{3.67 \text{ kW}}$$

(c) The power input and the COP are

$$\dot{W}_{\text{in}} = \dot{m}(h_2 - h_1) = (0.018 \text{ kg/s})(291.76 - 247.87) \text{ kJ/kg} = 0.790 \text{ kW}$$

$$\text{COP} = \frac{\dot{Q}_H}{\dot{W}_{\text{in}}} = \frac{3.67}{0.790} = \mathbf{4.64}$$

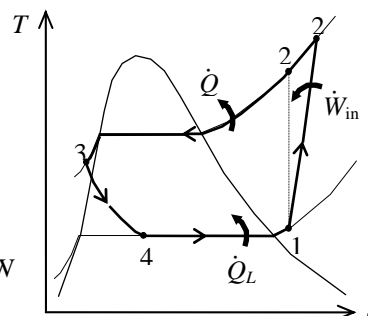

(d) The ideal vapor-compression cycle analysis of the cycle is as follows:

$$h_1 = h_{g@200 \text{ kPa}} = 244.46 \text{ kJ/kg}$$

$$s_1 = s_{g@200 \text{ kPa}} = 0.9377 \text{ kJ/kg}\cdot\text{K}$$

$$\left. \begin{array}{l} P_2 = 800 \text{ kPa} \\ s_2 = s_1 \end{array} \right\} h_2 = 273.25 \text{ kJ/kg}$$

$$h_3 = h_{f@800 \text{ kPa}} = 95.47 \text{ kJ/kg}$$

$$h_4 = h_3$$

$$\text{COP} = \frac{h_2 - h_3}{h_2 - h_1} = \frac{273.25 - 95.47}{273.25 - 244.46} = \mathbf{6.18}$$

$$\dot{Q}_H = \dot{m}(h_2 - h_3) = (0.018 \text{ kg/s})(273.25 - 95.47) \text{ kJ/kg} = \mathbf{3.20 \text{ kW}}$$

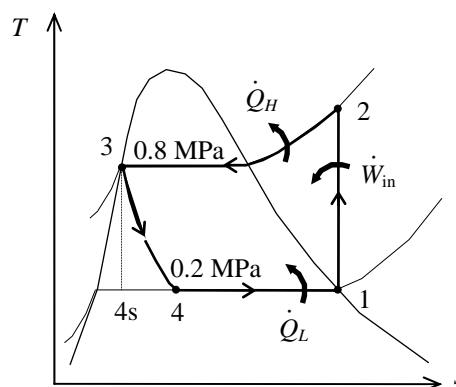

**11-34** A heat pump operating on the ideal vapor-compression refrigeration cycle with refrigerant-134a as the working fluid is considered. The COP and the rate of heat supplied to the evaporator are to be determined.

**Assumptions** 1 Steady operating conditions exist. 2 Kinetic and potential energy changes are negligible.

**Analysis** In an ideal vapor-compression refrigeration cycle, the compression process is isentropic, the refrigerant enters the compressor as a saturated vapor at the evaporator pressure, and leaves the condenser as saturated liquid at the condenser pressure. From the refrigerant tables (Tables A-11, A-12, and A-13),

$$\left. \begin{array}{l} P_1 = 280 \text{ kPa} \\ \text{sat. vapor} \end{array} \right\} \begin{array}{l} h_1 = h_g @ 280 \text{ kPa} = 249.72 \text{ kJ/kg} \\ s_1 = s_g @ 280 \text{ kPa} = 0.93210 \text{ kJ/kg} \cdot \text{K} \end{array}$$

$$\left. \begin{array}{l} P_2 = 1200 \text{ kPa} \\ s_2 = s_1 \end{array} \right\} h_2 = 280.00 \text{ kJ/kg}$$

$$\left. \begin{array}{l} P_3 = 1200 \text{ kPa} \\ \text{sat. liquid} \end{array} \right\} h_3 = h_f @ 1200 \text{ kPa} = 117.77 \text{ kJ/kg}$$

$$h_4 \cong h_3 = 117.77 \text{ kJ/kg} \quad (\text{throttling})$$

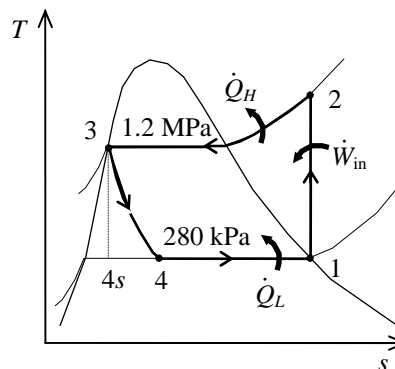

The mass flow rate of the refrigerant is determined from

$$\dot{W}_{\text{in}} = \dot{m}(h_2 - h_1) \longrightarrow \dot{m} = \frac{\dot{W}_{\text{in}}}{h_2 - h_1} = \frac{20 \text{ kJ/s}}{(280.00 - 249.72) \text{ kJ/kg}} = 0.6605 \text{ kg/s}$$

Then the rate of heat supplied to the evaporator is

$$\dot{Q}_L = \dot{m}(h_1 - h_4) = (0.6605 \text{ kg/s})(249.72 - 117.77) \text{ kJ/kg} = \mathbf{87.15 \text{ kW}}$$

The COP of the heat pump is determined from its definition,

$$\text{COP}_{\text{HP}} = \frac{q_H}{w_{\text{in}}} = \frac{h_2 - h_3}{h_2 - h_1} = \frac{280.00 - 117.77}{280.00 - 249.72} = \mathbf{5.36}$$

**11-35** A heat pump operating on a vapor-compression refrigeration cycle with refrigerant-134a as the working fluid is considered. The effect of compressor irreversibilities on the COP of the cycle is to be determined.

**Assumptions** 1 Steady operating conditions exist. 2 Kinetic and potential energy changes are negligible.

**Analysis** In this cycle, the refrigerant enters the compressor as a saturated vapor at the evaporator pressure, and leaves the condenser as saturated liquid at the condenser pressure. The compression process is not isentropic. The saturation pressure of refrigerant at  $-1.25^\circ\text{C}$  is 280 kPa. From the refrigerant tables (Tables A-11, A-12, and A-13),

$$\left. \begin{array}{l} P_1 = 280 \text{ kPa} \\ \text{sat. vapor} \end{array} \right\} \begin{array}{l} h_1 = h_g @ 280 \text{ kPa} = 249.72 \text{ kJ/kg} \\ s_1 = s_g @ 280 \text{ kPa} = 0.93210 \text{ kJ/kg} \cdot \text{K} \end{array}$$

$$\left. \begin{array}{l} P_2 = 800 \text{ kPa} \\ s_2 = s_1 \end{array} \right\} h_{2s} = 271.50 \text{ kJ/kg}$$

$$\left. \begin{array}{l} P_3 = 800 \text{ kPa} \\ \text{sat. liquid} \end{array} \right\} h_3 = h_f @ 800 \text{ kPa} = 95.47 \text{ kJ/kg}$$

$$h_4 \cong h_3 = 95.47 \text{ kJ/kg} \quad (\text{throttling})$$

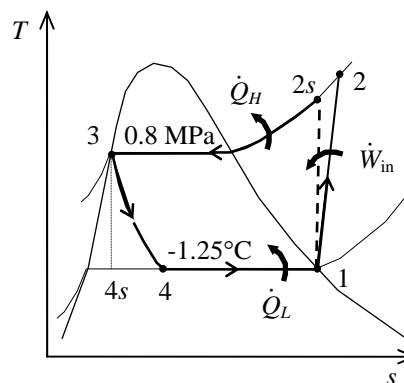

The actual enthalpy at the compressor exit is determined by using the compressor efficiency:

$$\eta_C = \frac{h_{2s} - h_1}{h_2 - h_1} \longrightarrow h_2 = h_1 + \frac{h_{2s} - h_1}{\eta_C} = 249.72 + \frac{271.50 - 249.72}{0.85} = 275.34 \text{ kJ/kg}$$

The COPs of the heat pump for isentropic and irreversible compression cases are

$$\text{COP}_{\text{HP, ideal}} = \frac{q_H}{w_{\text{in}}} = \frac{h_{2s} - h_3}{h_{2s} - h_1} = \frac{271.50 - 95.47}{271.50 - 249.72} = \mathbf{8.082}$$

$$\text{COP}_{\text{HP, actual}} = \frac{q_H}{w_{\text{in}}} = \frac{h_2 - h_3}{h_2 - h_1} = \frac{275.34 - 95.47}{275.34 - 249.72} = \mathbf{7.021}$$

The irreversible compressor decreases the COP by **13.1%**.



**11-36** A heat pump operating on a vapor-compression refrigeration cycle with refrigerant-134a as the working fluid is considered. The effect of superheating at the compressor inlet on the COP of the cycle is to be determined.

**Assumptions** 1 Steady operating conditions exist. 2 Kinetic and potential energy changes are negligible.

**Analysis** In this cycle, the compression process is isentropic and leaves the condenser as saturated liquid at the condenser pressure. The refrigerant entering the compressor is superheated by 2°C. The saturation pressure of refrigerant at -1.25°C is 280 kPa. From the refrigerant tables (Tables A-11, A-12, and A-13),

$$\left. \begin{array}{l} P_1 = 280 \text{ kPa} \\ T_1 = -1.25 + 2 = 1.25^\circ\text{C} \end{array} \right\} \begin{array}{l} h_1 = 251.96 \text{ kJ/kg} \\ s_1 = 0.9403 \text{ kJ/kg} \cdot \text{K} \end{array}$$

$$\left. \begin{array}{l} P_2 = 800 \text{ kPa} \\ s_2 = s_1 \end{array} \right\} h_2 = 274.04 \text{ kJ/kg}$$

$$\left. \begin{array}{l} P_3 = 800 \text{ kPa} \\ \text{sat. liquid} \end{array} \right\} h_3 = h_f @ 800 \text{ kPa} = 95.47 \text{ kJ/kg}$$

$$h_4 \cong h_3 = 95.47 \text{ kJ/kg} \quad (\text{throttling})$$

The states at the inlet and exit of the compressor when the refrigerant enters the compressor as a saturated vapor are

$$\left. \begin{array}{l} P_1 = 280 \text{ kPa} \\ \text{sat. vapor} \end{array} \right\} \begin{array}{l} h_1 = h_g @ 280 \text{ kPa} = 249.72 \text{ kJ/kg} \\ s_1 = s_g @ 280 \text{ kPa} = 0.93210 \text{ kJ/kg} \cdot \text{K} \end{array}$$

$$\left. \begin{array}{l} P_2 = 800 \text{ kPa} \\ s_2 = s_1 \end{array} \right\} h_{2s} = 271.50 \text{ kJ/kg}$$

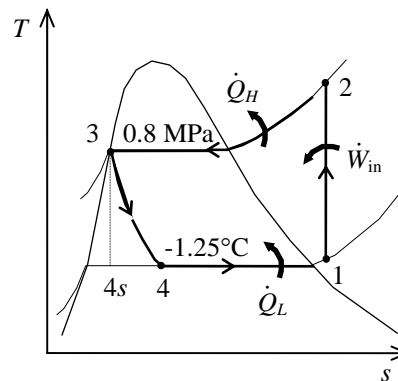

The COPs of the heat pump for the two cases are

$$\text{COP}_{\text{HP, ideal}} = \frac{q_H}{w_{\text{in}}} = \frac{h_{2s} - h_3}{h_{2s} - h_1} = \frac{271.50 - 95.47}{271.50 - 249.72} = \mathbf{8.082}$$

$$\text{COP}_{\text{HP, actual}} = \frac{q_H}{w_{\text{in}}} = \frac{h_2 - h_3}{h_2 - h_1} = \frac{274.04 - 95.47}{274.04 - 251.96} = \mathbf{8.087}$$

The effect of superheating on the COP is negligible.

**11-37E** A heat pump operating on the vapor-compression refrigeration cycle with refrigerant-134a as the working fluid is considered. The effect of subcooling at the exit of the condenser on the power requirement is to be determined.

**Assumptions** 1 Steady operating conditions exist. 2 Kinetic and potential energy changes are negligible.

**Analysis** In this cycle, the compression process is isentropic, the refrigerant enters the compressor as a saturated vapor at the evaporator pressure, and leaves the condenser as subcooled liquid. From the refrigerant tables (Tables A-11E, A-12E, and A-13E),

$$\left. \begin{array}{l} P_1 = 50 \text{ psia} \\ \text{sat. vapor} \end{array} \right\} \begin{array}{l} h_1 = h_g @ 50 \text{ psia} = 108.81 \text{ Btu/lbm} \\ s_1 = s_g @ 50 \text{ psia} = 0.22188 \text{ kJ/kg} \cdot \text{K} \end{array}$$

$$\left. \begin{array}{l} P_2 = 160 \text{ psia} \\ s_2 = s_1 \end{array} \right\} h_2 = 119.19 \text{ Btu/lbm}$$

$$T_3 = T_{\text{sat}} @ 160 \text{ psia} - 9.5 = 109.5 - 9.5 = 100^\circ\text{F}$$

$$\left. \begin{array}{l} P_3 = 160 \text{ psia} \\ T_3 = 100^\circ\text{F} \end{array} \right\} h_3 \cong h_f @ 100^\circ\text{F} = 45.124 \text{ Btu/lbm}$$

$$h_4 \cong h_3 = 45.124 \text{ Btu/lbm} \quad (\text{throttling})$$

The states at the inlet and exit of the expansion valve when the refrigerant is saturated liquid at the condenser exit are

$$\left. \begin{array}{l} P_3 = 160 \text{ psia} \\ \text{sat. liquid} \end{array} \right\} h_3 = h_f @ 160 \text{ psia} = 48.519 \text{ Btu/lbm}$$

$$h_4 \cong h_3 = 48.519 \text{ Btu/lbm} \quad (\text{throttling})$$

The mass flow rate of the refrigerant in the ideal case is

$$\dot{Q}_L = \dot{m}(h_1 - h_4) \longrightarrow \dot{m} = \frac{\dot{Q}_H}{h_2 - h_3} = \frac{100,000 \text{ Btu/h}}{(119.19 - 48.519) \text{ Btu/lbm}} = 1415.0 \text{ lbm/h}$$

The power requirement is

$$\dot{W}_{\text{in}} = \dot{m}(h_2 - h_1) = (1415.0 \text{ lbm/h})(119.19 - 108.81) \text{ Btu/lbm} \left( \frac{1 \text{ kW}}{3412.14 \text{ Btu/h}} \right) = \mathbf{4.305 \text{ kW}}$$

With subcooling, the mass flow rate and the power input are

$$\dot{Q}_L = \dot{m}(h_1 - h_4) \longrightarrow \dot{m} = \frac{\dot{Q}_H}{h_2 - h_3} = \frac{100,000 \text{ Btu/h}}{(119.19 - 45.124) \text{ Btu/lbm}} = 1350.1 \text{ lbm/h}$$

$$\dot{W}_{\text{in}} = \dot{m}(h_2 - h_1) = (1350.1 \text{ lbm/h})(119.19 - 108.81) \text{ Btu/lbm} \left( \frac{1 \text{ kW}}{3412.14 \text{ Btu/h}} \right) = \mathbf{4.107 \text{ kW}}$$

Subcooling decreases the power requirement by 4.6%.

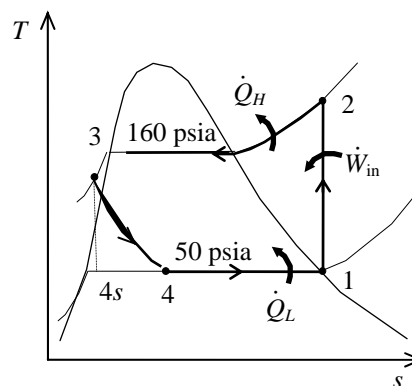

**11-38E** A heat pump operating on the vapor-compression refrigeration cycle with refrigerant-134a as the working fluid is considered. The effect of superheating at the compressor inlet on the power requirement is to be determined.

**Assumptions** 1 Steady operating conditions exist. 2 Kinetic and potential energy changes are negligible.

**Analysis** In this cycle, the compression process is isentropic and leaves the condenser as saturated liquid at the condenser pressure. The refrigerant entering the compressor is superheated by 10°F. The saturation temperature of the refrigerant at 50 psia is 40.23°F. From the refrigerant tables (Tables A-11E, A-12E, and A-13E),

$$\left. \begin{array}{l} P_1 = 50 \text{ psia} \\ T_1 = 40.23 + 10 = 50.2^\circ\text{F} \end{array} \right\} \begin{array}{l} h_1 = 110.99 \text{ Btu/lbm} \\ s_1 = 0.2262 \text{ kJ/kg} \cdot \text{K} \end{array}$$

$$\left. \begin{array}{l} P_2 = 160 \text{ psia} \\ s_2 = s_1 \end{array} \right\} h_2 = 121.71 \text{ Btu/lbm}$$

$$\left. \begin{array}{l} P_3 = 160 \text{ psia} \\ \text{sat. liquid} \end{array} \right\} h_3 = h_f @ 160 \text{ psia} = 48.519 \text{ Btu/lbm}$$

$$h_4 \cong h_3 = 48.519 \text{ Btu/lbm} \quad (\text{throttling})$$

The states at the inlet and exit of the compressor when the refrigerant enters the compressor as a saturated vapor are

$$\left. \begin{array}{l} P_1 = 50 \text{ psia} \\ \text{sat. vapor} \end{array} \right\} \begin{array}{l} h_1 = h_g @ 50 \text{ psia} = 108.81 \text{ Btu/lbm} \\ s_1 = s_g @ 50 \text{ psia} = 0.22188 \text{ kJ/kg} \cdot \text{K} \end{array}$$

$$\left. \begin{array}{l} P_2 = 160 \text{ psia} \\ s_2 = s_1 \end{array} \right\} h_2 = 119.19 \text{ Btu/lbm}$$

The mass flow rate of the refrigerant in the ideal case is

$$\dot{Q}_L = \dot{m}(h_1 - h_4) \longrightarrow \dot{m} = \frac{\dot{Q}_H}{h_2 - h_3} = \frac{100,000 \text{ Btu/h}}{(119.19 - 48.519) \text{ Btu/lbm}} = 1415.0 \text{ lbm/h}$$

The power requirement is

$$\dot{W}_{\text{in}} = \dot{m}(h_2 - h_1) = (1415.0 \text{ lbm/h})(119.19 - 108.81) \text{ Btu/lbm} \left( \frac{1 \text{ kW}}{3412.14 \text{ Btu/h}} \right) = \mathbf{4.305 \text{ kW}}$$

With superheating, the mass flow rate and the power input are

$$\dot{Q}_L = \dot{m}(h_1 - h_4) \longrightarrow \dot{m} = \frac{\dot{Q}_H}{h_2 - h_3} = \frac{100,000 \text{ Btu/h}}{(121.71 - 48.519) \text{ Btu/lbm}} = 1366.3 \text{ lbm/h}$$

$$\dot{W}_{\text{in}} = \dot{m}(h_2 - h_1) = (1366.3 \text{ lbm/h})(121.71 - 110.99) \text{ Btu/lbm} \left( \frac{1 \text{ kW}}{3412.14 \text{ Btu/h}} \right) = \mathbf{4.293 \text{ kW}}$$

Superheating decreases the power requirement slightly.

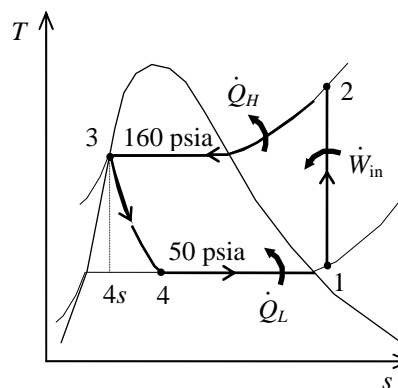

**11-39** A geothermal heat pump is considered. The degrees of subcooling done on the refrigerant in the condenser, the mass flow rate of the refrigerant, the heating load, the COP of the heat pump, the minimum power input are to be determined.

**Assumptions** 1 Steady operating conditions exist. 2 Kinetic and potential energy changes are negligible.

**Analysis** (a) From the refrigerant-134a tables (Tables A-11 through A-13)

$$\left. \begin{aligned} T_4 = 20^\circ\text{C} \\ x_4 = 0.23 \end{aligned} \right\} \begin{aligned} P_4 = 572.1 \text{ kPa} \\ h_4 = 121.24 \text{ kJ/kg} \end{aligned}$$

$$h_3 = h_4$$

$$\left. \begin{aligned} P_1 = 572.1 \text{ kPa} \\ x_1 = 1 \text{ (sat. vap.)} \end{aligned} \right\} \begin{aligned} h_1 = 261.59 \text{ kJ/kg} \\ s_1 = 0.9223 \text{ kJ/kg} \end{aligned}$$

$$\left. \begin{aligned} P_2 = 1400 \text{ kPa} \\ s_2 = s_1 \end{aligned} \right\} \begin{aligned} h_2 = 280.00 \text{ kJ/kg} \end{aligned}$$

From the steam tables (Table A-4)

$$h_{w1} = h_f @ 50^\circ\text{C} = 209.34 \text{ kJ/kg}$$

$$h_{w2} = h_f @ 40^\circ\text{C} = 167.53 \text{ kJ/kg}$$

The saturation temperature at the condenser pressure of 1400 kPa and the actual temperature at the condenser outlet are

$$T_{\text{sat @ 1400 kPa}} = 52.40^\circ\text{C}$$

$$\left. \begin{aligned} P_3 = 1400 \text{ kPa} \\ h_3 = 121.24 \text{ kJ} \end{aligned} \right\} T_3 = 48.59^\circ\text{C} \text{ (from EES)}$$

Then, the degrees of subcooling is

$$\Delta T_{\text{subcool}} = T_{\text{sat}} - T_3 = 52.40 - 48.59 = \mathbf{3.81^\circ\text{C}}$$

(b) The rate of heat absorbed from the geothermal water in the evaporator is

$$\dot{Q}_L = \dot{m}_w (h_{w1} - h_{w2}) = (0.065 \text{ kg/s})(209.34 - 167.53) \text{ kJ/kg} = 2.718 \text{ kW}$$

This heat is absorbed by the refrigerant in the evaporator

$$\dot{m}_R = \frac{\dot{Q}_L}{h_1 - h_4} = \frac{2.718 \text{ kW}}{(261.59 - 121.24) \text{ kJ/kg}} = \mathbf{0.01936 \text{ kg/s}}$$

(c) The power input to the compressor, the heating load and the COP are

$$\dot{W}_{\text{in}} = \dot{m}_R (h_2 - h_1) + \dot{Q}_{\text{out}} = (0.01936 \text{ kg/s})(280.00 - 261.59) \text{ kJ/kg} = 0.6564 \text{ kW}$$

$$\dot{Q}_H = \dot{m}_R (h_2 - h_3) = (0.01936 \text{ kg/s})(280.00 - 121.24) \text{ kJ/kg} = \mathbf{3.074 \text{ kW}}$$

$$\text{COP} = \frac{\dot{Q}_H}{\dot{W}_{\text{in}}} = \frac{3.074 \text{ kW}}{0.6564 \text{ kW}} = \mathbf{4.68}$$

(d) The reversible COP of the cycle is

$$\text{COP}_{\text{rev}} = \frac{1}{1 - T_L / T_H} = \frac{1}{1 - (25 + 273) / (50 + 273)} = 12.92$$

The corresponding minimum power input is

$$\dot{W}_{\text{in, min}} = \frac{\dot{Q}_H}{\text{COP}_{\text{rev}}} = \frac{3.074 \text{ kW}}{12.92} = \mathbf{0.238 \text{ kW}}$$

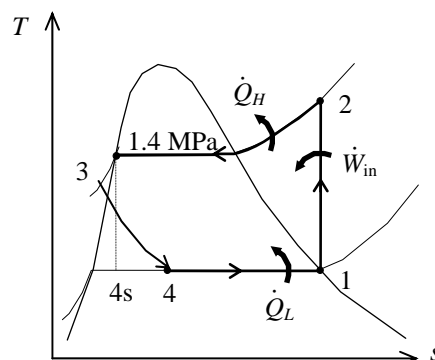
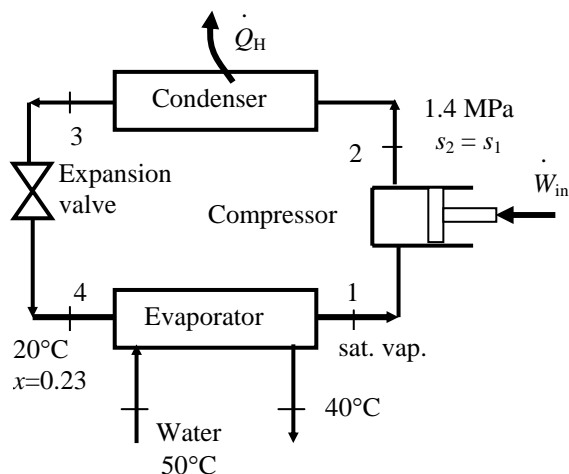

## Innovative Refrigeration Systems

**11-40C** Performing the refrigeration in stages is called cascade refrigeration. In cascade refrigeration, two or more refrigeration cycles operate in series. Cascade refrigerators are more complex and expensive, but they have higher COP's, they can incorporate two or more different refrigerants, and they can achieve much lower temperatures.

**11-41C** Cascade refrigeration systems have higher COPs than the ordinary refrigeration systems operating between the same pressure limits.

**11-42C** The saturation pressure of refrigerant-134a at  $-32^{\circ}\text{C}$  is 77 kPa, which is below the atmospheric pressure. In reality a pressure below this value should be used. Therefore, a cascade refrigeration system with a different refrigerant at the bottoming cycle is recommended in this case.

**11-43C** We would favor the two-stage compression refrigeration system with a flash chamber since it is simpler, cheaper, and has better heat transfer characteristics.

**11-44C** Yes, by expanding the refrigerant in stages in several throttling devices.

**11-45C** To take advantage of the cooling effect by throttling from high pressures to low pressures.

**11-46** [Also solved by EES on enclosed CD] A two-stage compression refrigeration system with refrigerant-134a as the working fluid is considered. The fraction of the refrigerant that evaporates as it is throttled to the flash chamber, the rate of heat removed from the refrigerated space, and the COP are to be determined.

**Assumptions** 1 Steady operating conditions exist. 2 Kinetic and potential energy changes are negligible. 3 The flash chamber is adiabatic.

**Analysis** (a) The enthalpies of the refrigerant at several states are determined from the refrigerant tables (Tables A-11, A-12, and A-13) to be

$$\begin{aligned} h_1 &= 239.16 \text{ kJ/kg}, & h_2 &= 265.31 \text{ kJ/kg} \\ h_3 &= 259.30 \text{ kJ/kg}, \\ h_5 &= 107.32 \text{ kJ/kg}, & h_6 &= 107.32 \text{ kJ/kg} \\ h_7 &= 73.33 \text{ kJ/kg}, & h_8 &= 73.33 \text{ kJ/kg} \end{aligned}$$

The fraction of the refrigerant that evaporates as it is throttled to the flash chamber is simply the quality at state 6,

$$x_6 = \frac{h_6 - h_f}{h_{fg}} = \frac{107.32 - 73.33}{185.98} = \mathbf{0.1828}$$

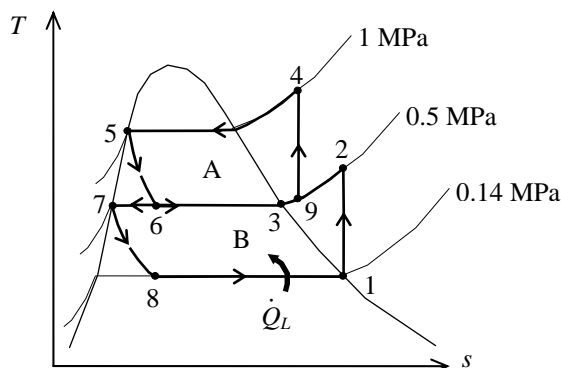

(b) The enthalpy at state 9 is determined from an energy balance on the mixing chamber:

$$\begin{aligned} \dot{E}_{in} - \dot{E}_{out} &= \Delta \dot{E}_{system} \stackrel{\neq 0 \text{ (steady)}}{=} 0 \\ \dot{E}_{in} &= \dot{E}_{out} \\ \sum \dot{m}_e h_e &= \sum \dot{m}_i h_i \\ (1)h_9 &= x_6 h_3 + (1 - x_6)h_2 \\ h_9 &= (0.1828)(259.30) + (1 - 0.1828)(265.31) = 264.21 \text{ kJ/kg} \end{aligned}$$

also,

$$\left. \begin{aligned} P_4 &= 1 \text{ MPa} \\ s_4 &= s_3 = 0.94083 \text{ kJ/kg} \cdot \text{K} \end{aligned} \right\} h_4 = 278.97 \text{ kJ/kg}$$

Then the rate of heat removed from the refrigerated space and the compressor work input per unit mass of refrigerant flowing through the condenser are

$$\begin{aligned} \dot{m}_B &= (1 - x_6)\dot{m}_A = (1 - 0.1828)(0.25 \text{ kg/s}) = 0.2043 \text{ kg/s} \\ \dot{Q}_L &= \dot{m}_B(h_1 - h_8) = (0.2043 \text{ kg/s})(239.16 - 73.33) \text{ kJ/kg} = \mathbf{33.88 \text{ kW}} \\ \dot{W}_{in} &= \dot{W}_{\text{compI, in}} + \dot{W}_{\text{compII, in}} = \dot{m}_A(h_4 - h_9) + \dot{m}_B(h_2 - h_1) \\ &= (0.25 \text{ kg/s})(278.97 - 264.21) \text{ kJ/kg} + (0.2043 \text{ kg/s})(265.31 - 239.16) \text{ kJ/kg} \\ &= 9.03 \text{ kW} \end{aligned}$$

(c) The coefficient of performance is determined from

$$\text{COP}_R = \frac{\dot{Q}_L}{\dot{W}_{\text{net, in}}} = \frac{33.88 \text{ kW}}{9.03 \text{ kW}} = \mathbf{3.75}$$

**11-47 EES** Problem 11-46 is reconsidered. The effects of the various refrigerants in EES data bank for compressor efficiencies of 80, 90, and 100 percent is to be investigated.

**Analysis** The problem is solved using EES, and the results are tabulated and plotted below.

#### "Input Data"

"P[1]=140 [kPa]  
 P[4] = 1000 [kPa]  
 P[6]=500 [kPa]  
 Eta\_compB =1.0  
 Eta\_compA =1.0"  
 m\_dot\_A=0.25 [kg/s]

#### "High Pressure Compressor A"

P[9]=P[6]  
 h4s=enthalpy(R134a,P=P[4],s=s[9]) "State 4s is the isentropic value of state 4"  
 h[9]+w\_compAs=h4s "energy balance on isentropic compressor"  
 w\_compA=w\_compAs/Eta\_compA "definition of compressor isentropic efficiency"  
 h[9]+w\_compA=h[4] "energy balance on real compressor-assumed adiabatic"  
 s[4]=entropy(R134a,h=h[4],P=P[4]) "properties for state 4"  
 T[4]=temperature(R134a,h=h[4],P=P[4])  
 W\_dot\_compA=m\_dot\_A\*w\_compA

#### "Condenser"

P[5]=P[4] "neglect pressure drops across condenser"  
 T[5]=temperature(R134a,P=P[5],x=0) "properties for state 5, assumes sat. liq. at cond. exit"  
 h[5]=enthalpy(R134a,T=T[5],x=0) "properties for state 5"  
 s[5]=entropy(R134a,T=T[5],x=0)  
 h[4]=q\_out+h[5] "energy balance on condenser"  
 Q\_dot\_out = m\_dot\_A\*q\_out

#### "Throttle Valve A"

h[6]=h[5] "energy balance on throttle - isenthalpic"  
 x6=quality(R134a,h=h[6],P=P[6]) "properties for state 6"  
 s[6]=entropy(R134a,h=h[6],P=P[6])  
 T[6]=temperature(R134a,h=h[6],P=P[6])

#### "Flash Chamber"

m\_dot\_B = (1-x6) \* m\_dot\_A  
 P[7] = P[6]  
 h[7]=enthalpy(R134a, P=P[7], x=0)  
 s[7]=entropy(R134a,h=h[7],P=P[7])  
 T[7]=temperature(R134a,h=h[7],P=P[7])

#### "Mixing Chamber"

x6\*m\_dot\_A\*h[3] + m\_dot\_B\*h[2] =(x6\* m\_dot\_A + m\_dot\_B)\*h[9]  
 P[3] = P[6]  
 h[3]=enthalpy(R134a, P=P[3], x=1) "properties for state 3"  
 s[3]=entropy(R134a,P=P[3],x=1)  
 T[3]=temperature(R134a,P=P[3],x=x1)  
 s[9]=entropy(R134a,h=h[9],P=P[9]) "properties for state 9"  
 T[9]=temperature(R134a,h=h[9],P=P[9])

#### "Low Pressure Compressor B"

x1=1 "assume flow to compressor inlet to be saturated vapor"

$h[1]=\text{enthalpy}(\text{R134a}, P=P[1], x=x1)$  "properties for state 1"  
 $T[1]=\text{temperature}(\text{R134a}, P=P[1], x=x1)$   
 $s[1]=\text{entropy}(\text{R134a}, P=P[1], x=x1)$   
 $P[2]=P[6]$   
 $h2s=\text{enthalpy}(\text{R134a}, P=P[2], s=s[1])$  "state 2s is isentropic state at comp. exit"  
 $h[1]+w_{\text{compB}}=h2s$  "energy balance on isentropic compressor"  
 $w_{\text{compB}}=w_{\text{compBs}}/\text{Eta}_{\text{compB}}$  "definition of compressor isentropic efficiency"  
 $h[1]+w_{\text{compB}}=h[2]$  "energy balance on real compressor-assumed adiabatic"  
 $s[2]=\text{entropy}(\text{R134a}, h=h[2], P=P[2])$  "properties for state 2"  
 $T[2]=\text{temperature}(\text{R134a}, h=h[2], P=P[2])$   
 $W_{\text{dot compB}}=m_{\text{dot B}}*w_{\text{compB}}$

#### "Throttle Valve B"

$h[8]=h[7]$  "energy balance on throttle - isenthalpic"  
 $x8=\text{quality}(\text{R134a}, h=h[8], P=P[8])$  "properties for state 8"  
 $s[8]=\text{entropy}(\text{R134a}, h=h[8], P=P[8])$   
 $T[8]=\text{temperature}(\text{R134a}, h=h[8], P=P[8])$

#### "Evaporator"

$P[8]=P[1]$  "neglect pressure drop across evaporator"  
 $q_{\text{in}} + h[8]=h[1]$  "energy balance on evaporator"  
 $Q_{\text{dot in}}=m_{\text{dot B}}*q_{\text{in}}$

#### "Cycle Statistics"

$W_{\text{dot in total}} = W_{\text{dot compA}} + W_{\text{dot compB}}$   
 $\text{COP} = Q_{\text{dot in}}/W_{\text{dot in total}}$  "definition of COP"

$\eta_{\text{compA}}$	$\eta_{\text{compB}}$	$Q_{\text{out}}$	COP
0,8	0,8	45.32	2.963
0,8333	0,8333	44.83	3.094
0,8667	0,8667	44.39	3.225
0,9	0,9	43.97	3.357
0,9333	0,9333	43.59	3.488
0,9667	0,9667	43.24	3.619
1	1	42.91	3.751

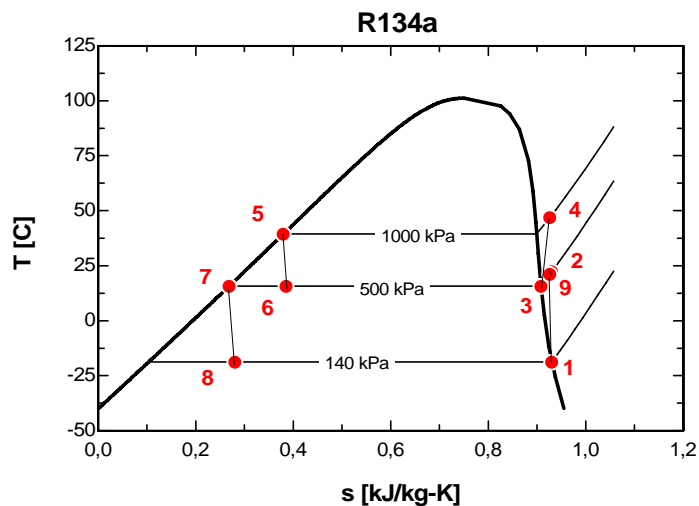



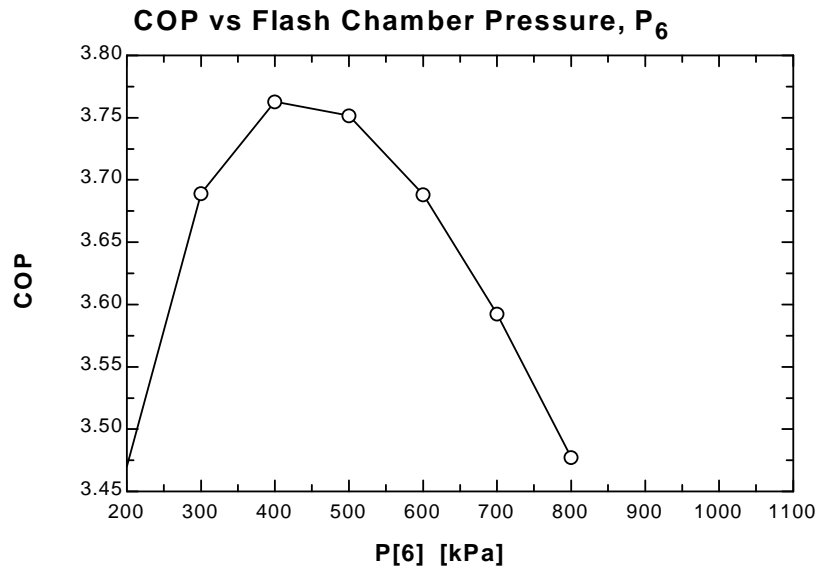
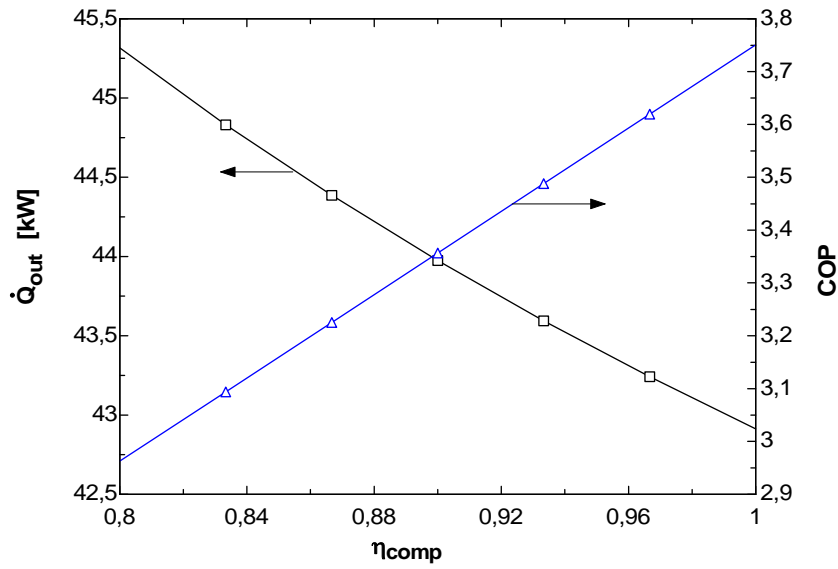

**11-48** [Also solved by EES on enclosed CD] A two-stage compression refrigeration system with refrigerant-134a as the working fluid is considered. The fraction of the refrigerant that evaporates as it is throttled to the flash chamber, the rate of heat removed from the refrigerated space, and the COP are to be determined.

**Assumptions** 1 Steady operating conditions exist. 2 Kinetic and potential energy changes are negligible. 3 The flash chamber is adiabatic.

**Analysis** (a) The enthalpies of the refrigerant at several states are determined from the refrigerant tables (Tables A-11, A-12, and A-13) to be

$$h_1 = 239.16 \text{ kJ/kg}, \quad h_2 = 255.90 \text{ kJ/kg}$$

$$h_3 = 251.88 \text{ kJ/kg},$$

$$h_5 = 107.32 \text{ kJ/kg}, \quad h_6 = 107.32 \text{ kJ/kg}$$

$$h_7 = 55.16 \text{ kJ/kg}, \quad h_8 = 55.16 \text{ kJ/kg}$$

The fraction of the refrigerant that evaporates as it is throttled to the flash chamber is simply the quality at state 6,

$$x_6 = \frac{h_6 - h_f}{h_{fg}} = \frac{107.32 - 55.16}{196.71} = \mathbf{0.2651}$$

(b) The enthalpy at state 9 is determined from an energy balance on the mixing chamber:

$$\dot{E}_{\text{in}} - \dot{E}_{\text{out}} = \Delta \dot{E}_{\text{system}} \stackrel{\phi=0 \text{ (steady)}}{=} 0$$

$$\dot{E}_{\text{in}} = \dot{E}_{\text{out}}$$

$$\sum \dot{m}_e h_e = \sum \dot{m}_i h_i$$

$$(1)h_9 = x_6 h_3 + (1 - x_6)h_2$$

$$h_9 = (0.2651)(251.88) + (1 - 0.2651)(255.90) = 254.84 \text{ kJ/kg}$$

and

$$\left. \begin{array}{l} P_9 = 0.32 \text{ MPa} \\ h_9 = 254.84 \text{ kJ/kg} \end{array} \right\} s_9 = 0.94074 \text{ kJ/kg} \cdot \text{K}$$

$$\text{also, } \left. \begin{array}{l} P_4 = 1 \text{ MPa} \\ s_4 = s_9 = 0.94074 \text{ kJ/kg} \cdot \text{K} \end{array} \right\} h_4 = 278.94 \text{ kJ/kg}$$

Then the rate of heat removed from the refrigerated space and the compressor work input per unit mass of refrigerant flowing through the condenser are

$$\dot{m}_B = (1 - x_6)\dot{m}_A = (1 - 0.2651)(0.25 \text{ kg/s}) = 0.1837 \text{ kg/s}$$

$$\dot{Q}_L = \dot{m}_B(h_1 - h_8) = (0.1837 \text{ kg/s})(239.16 - 55.16) \text{ kJ/kg} = \mathbf{33.80 \text{ kW}}$$

$$\begin{aligned} \dot{W}_{\text{in}} &= \dot{W}_{\text{compI,in}} + \dot{W}_{\text{compII,in}} = \dot{m}_A(h_4 - h_9) + \dot{m}_B(h_2 - h_1) \\ &= (0.25 \text{ kg/s})(278.94 - 254.84) \text{ kJ/kg} + (0.1837 \text{ kg/s})(255.90 - 239.16) \text{ kJ/kg} \\ &= \mathbf{9.10 \text{ kW}} \end{aligned}$$

(c) The coefficient of performance is determined from

$$\text{COP}_R = \frac{\dot{Q}_L}{\dot{W}_{\text{net,in}}} = \frac{33.80 \text{ kW}}{9.10 \text{ kW}} = \mathbf{3.71}$$

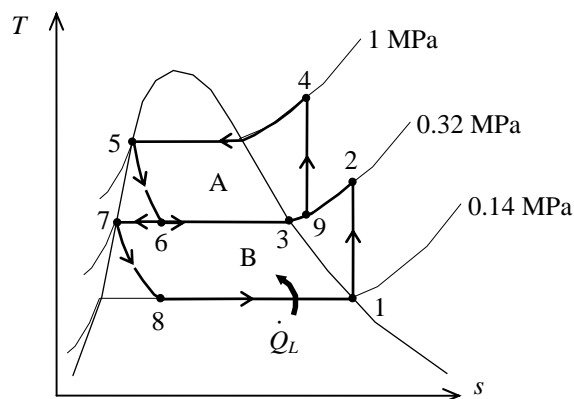

**11-49** A two-stage cascade refrigeration cycle is considered. The mass flow rate of the refrigerant through the upper cycle, the rate of heat removal from the refrigerated space, and the COP of the refrigerator are to be determined.

**Assumptions** 1 Steady operating conditions exist. 2 Kinetic and potential energy changes are negligible.

**Analysis** (a) The properties are to be obtained from the refrigerant tables (Tables A-11 through A-13):

$$h_1 = h_g @ 200 \text{ kPa} = 244.46 \text{ kJ/kg}$$

$$s_1 = s_g @ 200 \text{ kPa} = 0.9377 \text{ kJ/kg}\cdot\text{K}$$

$$\left. \begin{array}{l} P_2 = 500 \text{ kPa} \\ s_2 = s_1 \end{array} \right\} h_{2s} = 263.30 \text{ kJ/kg}$$

$$\eta_C = \frac{h_{2s} - h_1}{h_2 - h_1}$$

$$0.80 = \frac{263.30 - 244.46}{h_2 - 244.46} \longrightarrow h_2 = 268.01 \text{ kJ/kg}$$

$$h_3 = h_f @ 500 \text{ kPa} = 73.33 \text{ kJ/kg}$$

$$h_4 = h_3 = 73.33 \text{ kJ/kg}$$

$$h_5 = h_g @ 400 \text{ kPa} = 255.55 \text{ kJ/kg}$$

$$s_5 = s_g @ 400 \text{ kPa} = 0.9269 \text{ kJ/kg}\cdot\text{K}$$

$$\left. \begin{array}{l} P_6 = 1200 \text{ kPa} \\ s_6 = s_5 \end{array} \right\} h_{6s} = 278.33 \text{ kJ/kg}$$

$$\eta_C = \frac{h_{6s} - h_5}{h_6 - h_5}$$

$$0.80 = \frac{278.33 - 255.55}{h_6 - 255.55} \longrightarrow h_6 = 284.02 \text{ kJ/kg}$$

$$h_7 = h_f @ 1200 \text{ kPa} = 117.77 \text{ kJ/kg}$$

$$h_8 = h_7 = 117.77 \text{ kJ/kg}$$

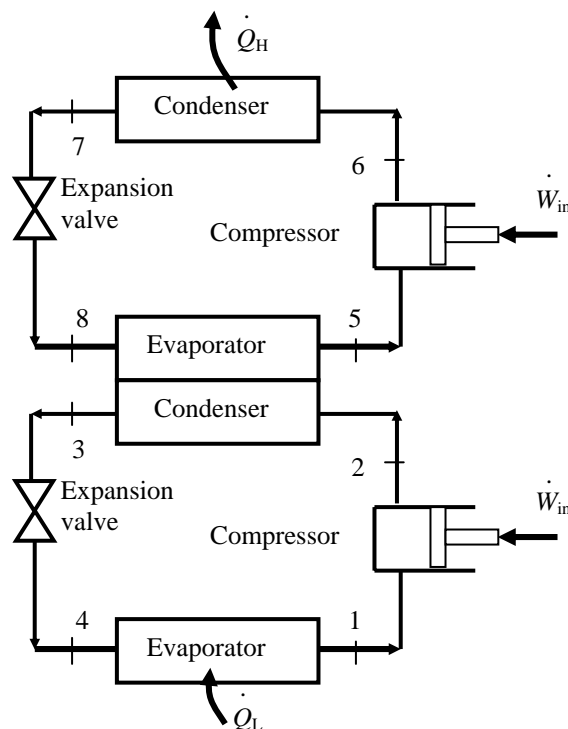

The mass flow rate of the refrigerant through the upper cycle is determined from an energy balance on the heat exchanger

$$\dot{m}_A (h_5 - h_8) = \dot{m}_B (h_2 - h_3)$$

$$\dot{m}_A (255.55 - 117.77) \text{ kJ/kg} = (0.15 \text{ kg/s})(268.01 - 73.33) \text{ kJ/kg} \longrightarrow \dot{m}_A = \mathbf{0.212 \text{ kg/s}}$$

(b) The rate of heat removal from the refrigerated space is

$$\dot{Q}_L = \dot{m}_B (h_1 - h_4) = (0.15 \text{ kg/s})(244.46 - 73.33) \text{ kJ/kg} = \mathbf{25.67 \text{ kW}}$$

(c) The power input and the COP are

$$\begin{aligned} \dot{W}_{\text{in}} &= \dot{m}_A (h_6 - h_5) + \dot{m}_B (h_2 - h_1) \\ &= (0.15 \text{ kg/s})(284.02 - 255.55) \text{ kJ/kg} + (0.212 \text{ kg/s})(268.01 - 244.46) \text{ kJ/kg} = 9.566 \text{ kW} \end{aligned}$$

$$\text{COP} = \frac{\dot{Q}_L}{\dot{W}_{\text{in}}} = \frac{25.67}{9.566} = \mathbf{2.68}$$

**11-50** A two-evaporator compression refrigeration cycle with refrigerant-134a as the working fluid is considered. The cooling rate of the high-temperature evaporator, the power required by the compressor, and the COP of the system are to be determined.

**Assumptions** 1 Steady operating conditions exist. 2 Kinetic and potential energy changes are negligible.

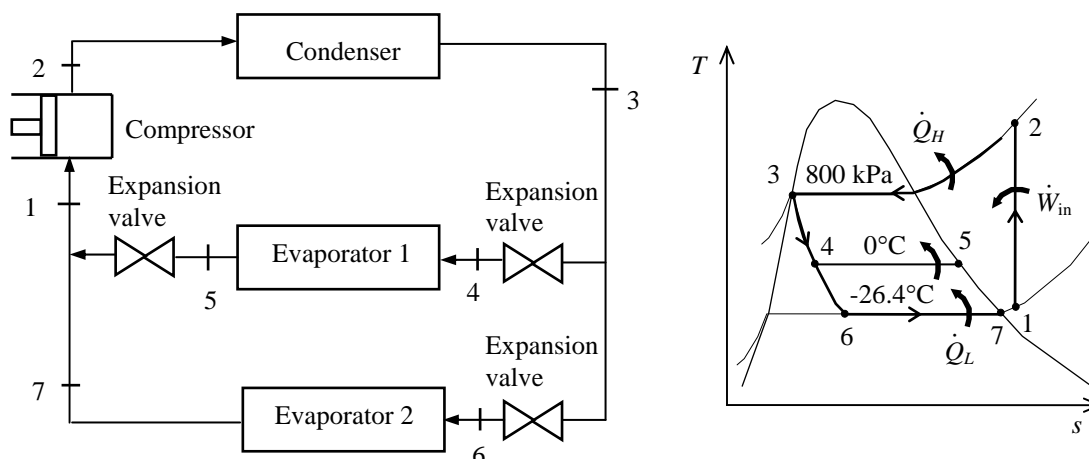

**Analysis** From the refrigerant tables (Tables A-11, A-12, and A-13),

$$\left. \begin{array}{l} P_3 = 800 \text{ kPa} \\ \text{sat. liquid} \end{array} \right\} h_3 = h_f @ 800 \text{ kPa} = 95.47 \text{ kJ/kg}$$

$$h_4 = h_6 \cong h_3 = 95.47 \text{ kJ/kg} \quad (\text{throttling})$$

$$\left. \begin{array}{l} T_5 = 0^\circ\text{C} \\ \text{sat. vapor} \end{array} \right\} h_5 = h_g @ 0^\circ\text{C} = 250.45 \text{ kJ/kg}$$

$$\left. \begin{array}{l} T_7 = -26.4^\circ\text{C} \\ \text{sat. vapor} \end{array} \right\} h_7 = h_g @ -26.4^\circ\text{C} = 234.44 \text{ kJ/kg}$$

The mass flow rate through the low-temperature evaporator is found by

$$\dot{Q}_L = \dot{m}_2(h_7 - h_6) \longrightarrow \dot{m}_2 = \frac{\dot{Q}_L}{h_7 - h_6} = \frac{8 \text{ kJ/s}}{(234.44 - 95.47) \text{ kJ/kg}} = 0.05757 \text{ kg/s}$$

The mass flow rate through the warmer evaporator is then

$$\dot{m}_1 = \dot{m} - \dot{m}_2 = 0.1 - 0.05757 = 0.04243 \text{ kg/s}$$

Applying an energy balance to the point in the system where the two evaporator streams are recombined gives

$$\dot{m}_1 h_5 + \dot{m}_2 h_7 = \dot{m} h_1 \longrightarrow h_1 = \frac{\dot{m}_1 h_5 + \dot{m}_2 h_7}{\dot{m}} = \frac{(0.04243)(250.45) + (0.05757)(234.44)}{0.1} = 241.23 \text{ kJ/kg}$$

Then,

$$\left. \begin{array}{l} P_1 = P_{\text{sat @ } -26.4^\circ\text{C}} \cong 100 \text{ kPa} \\ h_1 = 241.23 \text{ kJ/kg} \end{array} \right\} s_1 = 0.9789 \text{ kJ/kg} \cdot \text{K}$$

$$\left. \begin{array}{l} P_2 = 800 \text{ kPa} \\ s_2 = s_1 \end{array} \right\} h_2 = 286.26 \text{ kJ/kg}$$

The cooling rate of the high-temperature evaporator is

$$\dot{Q}_L = \dot{m}_1(h_5 - h_4) = (0.04243 \text{ kg/s})(250.45 - 95.47) \text{ kJ/kg} = \mathbf{6.58 \text{ kW}}$$

The power input to the compressor is

$$\dot{W}_{\text{in}} = \dot{m}(h_2 - h_1) = (0.1 \text{ kg/s})(286.26 - 241.23) \text{ kJ/kg} = \mathbf{4.50 \text{ kW}}$$

The COP of this refrigeration system is determined from its definition,

$$\text{COP}_R = \frac{\dot{Q}_L}{\dot{W}_{\text{in}}} = \frac{(8 + 6.58) \text{ kW}}{4.50 \text{ kW}} = \mathbf{3.24}$$

**11-51E** A two-evaporator compression refrigeration cycle with refrigerant-134a as the working fluid is considered. The power required by the compressor and the COP of the system are to be determined.

**Assumptions** 1 Steady operating conditions exist. 2 Kinetic and potential energy changes are negligible.

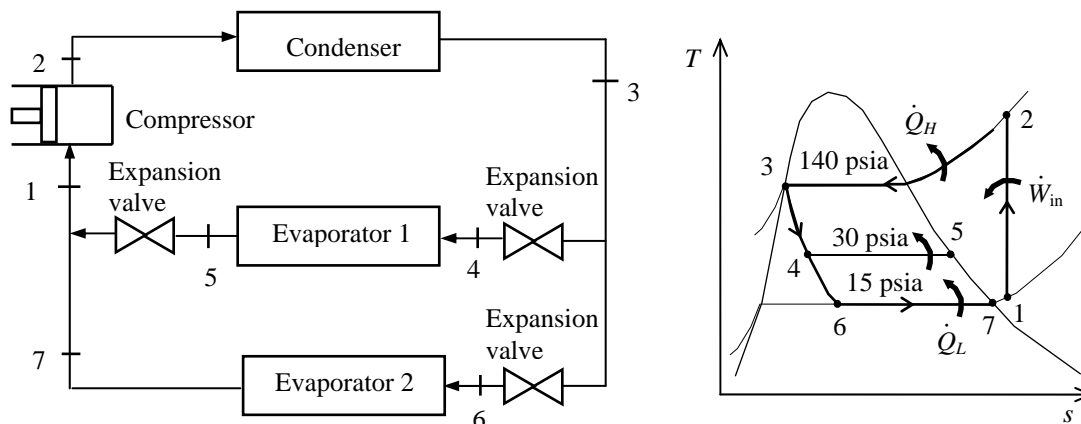

**Analysis** From the refrigerant tables (Tables A-11E, A-12E, and A-13E),

$$\left. \begin{array}{l} P_3 = 140 \text{ psia} \\ \text{sat. liquid} \end{array} \right\} h_3 = h_f @ 140 \text{ psia} = 45.304 \text{ Btu/lbm}$$

$$h_4 = h_6 \cong h_3 = 45.304 \text{ Btu/lbm} \quad (\text{throttling})$$

$$\left. \begin{array}{l} P_5 = 30 \text{ psia} \\ \text{sat. vapor} \end{array} \right\} h_5 = h_g @ 30 \text{ psia} = 105.32 \text{ Btu/lbm}$$

$$\left. \begin{array}{l} P_7 = 15 \text{ psia} \\ \text{sat. vapor} \end{array} \right\} h_7 = h_g @ 15 \text{ psia} = 100.99 \text{ Btu/lbm}$$

The mass flow rates through the high-temperature and low-temperature evaporators are found by

$$\dot{Q}_{L,1} = \dot{m}_1(h_5 - h_4) \longrightarrow \dot{m}_1 = \frac{\dot{Q}_{L,1}}{h_5 - h_4} = \frac{3000 \text{ Btu/h}}{(105.32 - 45.304) \text{ Btu/lbm}} = 49.99 \text{ lbm/h}$$

$$\dot{Q}_{L,2} = \dot{m}_2(h_7 - h_6) \longrightarrow \dot{m}_2 = \frac{\dot{Q}_{L,2}}{h_7 - h_6} = \frac{10,000 \text{ Btu/h}}{(100.99 - 45.304) \text{ Btu/lbm}} = 179.58 \text{ lbm/h}$$

Applying an energy balance to the point in the system where the two evaporator streams are recombined gives

$$\dot{m}_1 h_5 + \dot{m}_2 h_7 = (\dot{m}_1 + \dot{m}_2) h_1 \longrightarrow h_1 = \frac{\dot{m}_1 h_5 + \dot{m}_2 h_7}{\dot{m}_1 + \dot{m}_2} = \frac{(49.99)(105.32) + (179.58)(100.99)}{49.99 + 179.58} = 101.93 \text{ Btu/lbm}$$

Then,

$$\left. \begin{array}{l} P_1 = 15 \text{ psia} \\ h_1 = 101.93 \text{ Btu/lbm} \end{array} \right\} s_1 = 0.2293 \text{ Btu/lbm} \cdot \text{R}$$

$$\left. \begin{array}{l} P_2 = 140 \text{ psia} \\ s_2 = s_1 \end{array} \right\} h_2 = 122.24 \text{ Btu/lbm}$$

The power input to the compressor is

$$\dot{W}_{\text{in}} = (\dot{m}_1 + \dot{m}_2)(h_2 - h_1) = (49.99 + 179.58) \text{ lbm/h} (122.24 - 101.93) \text{ Btu/lbm} \left( \frac{1 \text{ kW}}{3412.14 \text{ Btu/h}} \right) = \mathbf{1.366 \text{ kW}}$$

The COP of this refrigeration system is determined from its definition,

$$\text{COP}_R = \frac{\dot{Q}_L}{\dot{W}_{\text{in}}} = \frac{(10,000 + 3000) \text{ Btu/h}}{1.366 \text{ kW}} \left( \frac{1 \text{ kW}}{3412.14 \text{ Btu/h}} \right) = \mathbf{2.79}$$

**11-52E** A two-evaporator compression refrigeration cycle with refrigerant-134a as the working fluid is considered. The power required by the compressor and the COP of the system are to be determined.

**Assumptions** 1 Steady operating conditions exist. 2 Kinetic and potential energy changes are negligible.

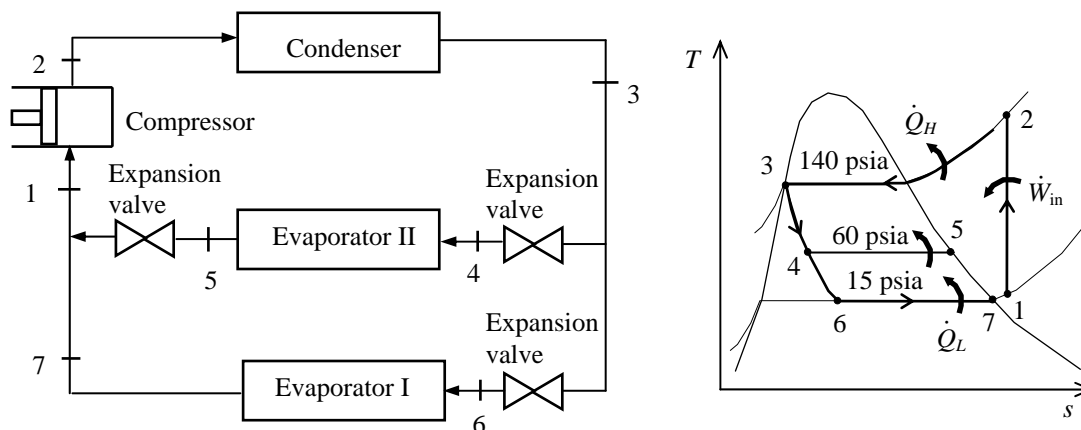

**Analysis** From the refrigerant tables (Tables A-11E, A-12E, and A-13E),

$$\left. \begin{array}{l} P_3 = 140 \text{ psia} \\ \text{sat. liquid} \end{array} \right\} h_3 = h_f @ 140 \text{ psia} = 45.304 \text{ Btu/lbm}$$

$$h_4 = h_6 \cong h_3 = 45.304 \text{ Btu/lbm} \quad (\text{throttling})$$

$$\left. \begin{array}{l} P_5 = 60 \text{ psia} \\ \text{sat. vapor} \end{array} \right\} h_5 = h_g @ 60 \text{ psia} = 110.11 \text{ Btu/lbm}$$

$$\left. \begin{array}{l} P_7 = 15 \text{ psia} \\ \text{sat. vapor} \end{array} \right\} h_7 = h_g @ 15 \text{ psia} = 100.99 \text{ Btu/lbm}$$

The mass flow rates through the high-temperature and low-temperature evaporators are found by

$$\dot{Q}_{L,1} = \dot{m}_1(h_5 - h_4) \longrightarrow \dot{m}_1 = \frac{\dot{Q}_{L,1}}{h_5 - h_4} = \frac{48,000 \text{ Btu/h}}{(110.11 - 45.304) \text{ Btu/lbm}} = 740.7 \text{ lbm/h}$$

$$\dot{Q}_{L,2} = \dot{m}_2(h_7 - h_6) \longrightarrow \dot{m}_2 = \frac{\dot{Q}_{L,2}}{h_7 - h_6} = \frac{10,000 \text{ Btu/h}}{(100.99 - 45.304) \text{ Btu/lbm}} = 179.6 \text{ lbm/h}$$

Applying an energy balance to the point in the system where the two evaporator streams are recombined gives

$$\dot{m}_1 h_5 + \dot{m}_2 h_7 = (\dot{m}_1 + \dot{m}_2) h_1 \longrightarrow h_1 = \frac{\dot{m}_1 h_5 + \dot{m}_2 h_7}{\dot{m}_1 + \dot{m}_2} = \frac{(740.7)(110.11) + (179.58)(100.99)}{740.7 + 179.58} = 108.33 \text{ Btu/lbm}$$

Then,

$$\left. \begin{array}{l} P_1 = 15 \text{ psia} \\ h_1 = 108.33 \text{ Btu/lbm} \end{array} \right\} s_1 = 0.2430 \text{ Btu/lbm} \cdot \text{R}$$

$$\left. \begin{array}{l} P_2 = 140 \text{ psia} \\ s_2 = s_1 \end{array} \right\} h_2 = 130.45 \text{ Btu/lbm}$$

The power input to the compressor is

$$\dot{W}_{\text{in}} = (\dot{m}_1 + \dot{m}_2)(h_2 - h_1) = (740.7 + 179.6) \text{ lbm/h}(130.45 - 108.33) \text{ Btu/lbm} \left( \frac{1 \text{ kW}}{3412.14 \text{ Btu/h}} \right) = \mathbf{5.966 \text{ kW}}$$

The COP of this refrigeration system is determined from its definition,

$$\text{COP}_R = \frac{\dot{Q}_L}{\dot{W}_{\text{in}}} = \frac{(48,000 + 10,000) \text{ Btu/h}}{5.966 \text{ kW}} \left( \frac{1 \text{ kW}}{3412.14 \text{ Btu/h}} \right) = \mathbf{2.85}$$

**11-53** A two-stage compression refrigeration system with a separation unit is considered. The mass flow rate through the two compressors, the power used by the compressors, and the system's COP are to be determined.

**Assumptions 1** Steady operating conditions exist. **2** Kinetic and potential energy changes are negligible.

**Analysis** From the refrigerant tables (Tables A-11, A-12, and A-13),

$$T_1 = -10.1^\circ\text{C} \left. \begin{array}{l} h_1 = h_g @ -10.1^\circ\text{C} = 244.46 \text{ kJ/kg} \\ s_1 = s_g @ -10.1^\circ\text{C} = 0.93773 \text{ kJ/kg}\cdot\text{K} \end{array} \right\}$$

$$P_2 = 800 \text{ kPa} \left. \begin{array}{l} h_2 = 273.24 \text{ kJ/kg} \\ s_2 = s_1 \end{array} \right\}$$

$$P_3 = 800 \text{ kPa} \left. \begin{array}{l} h_3 = h_f @ 800 \text{ kPa} = 95.47 \text{ kJ/kg} \\ \text{sat. liquid} \end{array} \right\}$$

$$h_4 \cong h_3 = 95.47 \text{ kJ/kg} \quad (\text{throttling})$$

$$T_5 = -10.1^\circ\text{C} \left. \begin{array}{l} h_5 = h_f @ -10.1^\circ\text{C} = 38.43 \text{ kJ/kg} \\ \text{sat. liquid} \end{array} \right\}$$

$$h_6 \cong h_5 = 38.43 \text{ kJ/kg} \quad (\text{throttling})$$

$$T_7 = -40^\circ\text{C} \left. \begin{array}{l} h_7 = h_g @ -40^\circ\text{C} = 225.86 \text{ kJ/kg} \\ \text{sat. vapor} \end{array} \right\} \quad s_7 = s_g @ -40^\circ\text{C} = 0.96866 \text{ kJ/kg}\cdot\text{K}$$

$$P_8 = P_{\text{sat}} @ -10.1^\circ\text{C} = 200 \text{ kPa} \left. \begin{array}{l} h_8 = 252.74 \text{ kJ/kg} \\ s_8 = s_7 \end{array} \right\}$$

The mass flow rate through the evaporator is determined from

$$\dot{Q}_L = \dot{m}_6(h_7 - h_6) \longrightarrow \dot{m}_6 = \frac{\dot{Q}_L}{h_7 - h_6} = \frac{30 \text{ kJ/s}}{(225.86 - 38.43) \text{ kJ/kg}} = \mathbf{0.1601 \text{ kg/s}}$$

An energy balance on the separator gives

$$\dot{m}_6(h_8 - h_5) = \dot{m}_2(h_1 - h_4) \longrightarrow \dot{m}_2 = \dot{m}_6 \frac{h_8 - h_5}{h_1 - h_4} = (0.1601) \frac{252.74 - 38.43}{244.46 - 95.47} = \mathbf{0.2303 \text{ kg/s}}$$

The total power input to the compressors is

$$\begin{aligned} \dot{W}_{\text{in}} &= \dot{m}_6(h_8 - h_7) + \dot{m}_2(h_2 - h_1) \\ &= (0.1601 \text{ kg/s})(252.74 - 225.86) \text{ kJ/kg} + (0.2303 \text{ kg/s})(273.24 - 244.46) \text{ kJ/kg} \\ &= \mathbf{10.93 \text{ kW}} \end{aligned}$$

The COP of this refrigeration system is determined from its definition,

$$\text{COP}_R = \frac{\dot{Q}_L}{\dot{W}_{\text{in}}} = \frac{30 \text{ kW}}{10.93 \text{ kW}} = \mathbf{2.74}$$

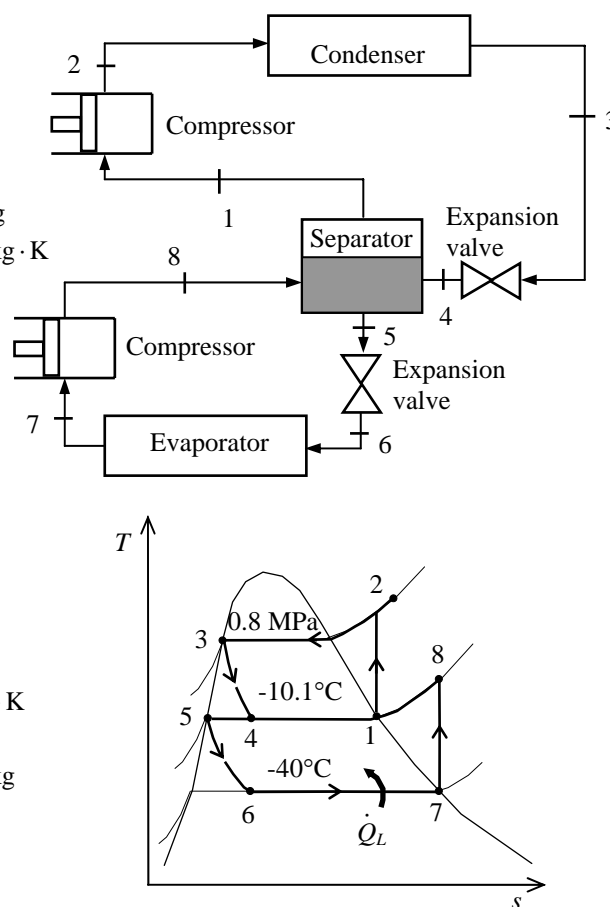



**11-54E** A two-stage compression refrigeration system with a separation unit is considered. The cooling load and the system's COP are to be determined.

**Assumptions 1** Steady operating conditions exist. **2** Kinetic and potential energy changes are negligible.

**Analysis** From the refrigerant tables (Tables A-11E, A-12E, and A-13E),

$$\left. \begin{array}{l} P_1 = 120 \text{ psia} \\ \text{sat. vapor} \end{array} \right\} \begin{array}{l} h_1 = h_g @ 120 \text{ psia} = 115.16 \text{ Btu/lbm} \\ s_1 = s_g @ 120 \text{ psia} = 0.21924 \text{ Btu/lbm} \cdot \text{R} \end{array}$$

$$\left. \begin{array}{l} P_2 = 300 \text{ psia} \\ s_2 = s_1 \end{array} \right\} h_2 = 123.06 \text{ Btu/lbm}$$

$$\left. \begin{array}{l} P_3 = 300 \text{ psia} \\ \text{sat. liquid} \end{array} \right\} h_3 = h_f @ 300 \text{ psia} = 66.339 \text{ Btu/lbm}$$

$$h_4 \cong h_3 = 66.339 \text{ Btu/lbm} \quad (\text{throttling})$$

$$\left. \begin{array}{l} P_5 = 120 \text{ psia} \\ \text{sat. liquid} \end{array} \right\} h_5 = h_f @ 120 \text{ psia} = 41.787 \text{ Btu/lbm}$$

$$h_6 \cong h_5 = 41.787 \text{ kJ/kg} \quad (\text{throttling})$$

$$\left. \begin{array}{l} P_7 = 60 \text{ psia} \\ \text{sat. vapor} \end{array} \right\} \begin{array}{l} h_7 = h_g @ 60 \text{ psia} = 110.11 \text{ Btu/lbm} \\ s_7 = s_g @ 60 \text{ psia} = 0.22127 \text{ Btu/lbm} \cdot \text{R} \end{array}$$

$$\left. \begin{array}{l} P_8 = 120 \text{ psia} \\ s_8 = s_7 \end{array} \right\} h_8 = 116.28 \text{ Btu/lbm}$$

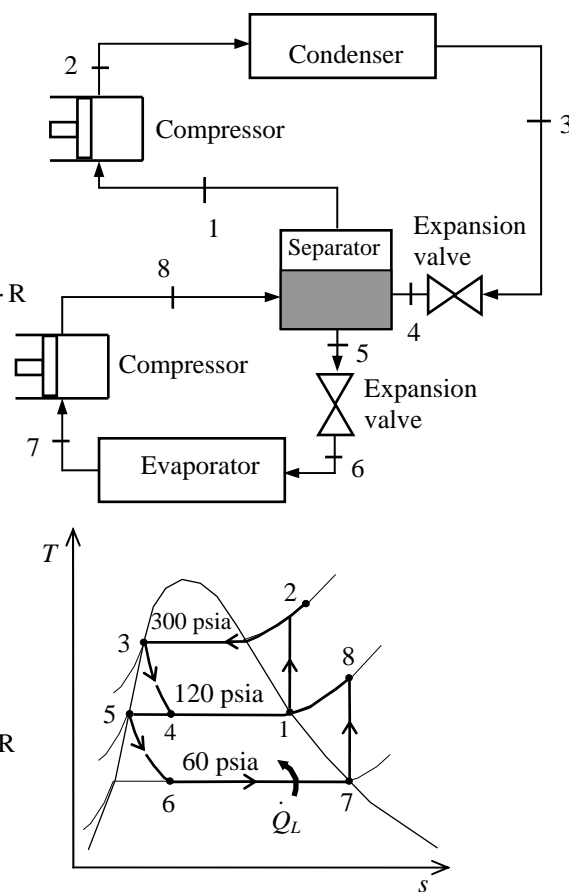

An energy balance on the separator gives

$$\dot{m}_6(h_8 - h_5) = \dot{m}_2(h_1 - h_4) \longrightarrow \dot{m}_2 = \dot{m}_6 \frac{h_8 - h_5}{h_1 - h_4} = \dot{m}_6 \frac{116.28 - 41.787}{115.16 - 66.339} = 1.5258\dot{m}_6$$

The total power input to the compressors is given by

$$\begin{aligned} \dot{W}_{\text{in}} &= \dot{m}_6(h_8 - h_7) + \dot{m}_2(h_2 - h_1) \\ &= \dot{m}_6(h_8 - h_7) + 1.5258\dot{m}_6(h_2 - h_1) \end{aligned}$$

Solving for  $\dot{m}_6$ ,

$$\dot{m}_6 = \frac{\dot{W}_{\text{in}}}{(h_8 - h_7) + 1.5258(h_2 - h_1)} = \frac{(25 \times 3412.14) \text{ Btu/h}}{(116.28 - 110.11) + 1.5258(123.06 - 115.16) \text{ Btu/lbm}} = 4681 \text{ lbm/h}$$

The cooling effect produced by this system is then

$$\dot{Q}_L = \dot{m}_6(h_7 - h_6) = (4681 \text{ lbm/h})(110.11 - 41.787) \text{ Btu/lbm} = \mathbf{319,800 \text{ Btu/h}}$$

The COP of this refrigeration system is determined from its definition,

$$\text{COP}_R = \frac{\dot{Q}_L}{\dot{W}_{\text{in}}} = \frac{(319,800/3412.14) \text{ kW}}{25 \text{ kW}} = \mathbf{3.75}$$

**11-55** A two-stage cascade refrigeration system is considered. Each stage operates on the ideal vapor-compression cycle with upper cycle using water and lower cycle using refrigerant-134a as the working fluids. The mass flow rate of R-134a and water in their respective cycles and the overall COP of this system are to be determined.

**Assumptions** 1 Steady operating conditions exist. 2 Kinetic and potential energy changes are negligible. 3 The heat exchanger is adiabatic.

**Analysis** From the water and refrigerant tables (Tables A-4, A-5, A-6, A-11, A-12, and A-13),

$$\left. \begin{array}{l} T_1 = 5^\circ\text{C} \\ \text{sat. vapor} \end{array} \right\} \begin{array}{l} h_1 = h_g @ 5^\circ\text{C} = 2510.1 \text{ kJ/kg} \\ s_1 = s_g @ 5^\circ\text{C} = 9.0249 \text{ kJ/kg} \cdot \text{K} \end{array}$$

$$\left. \begin{array}{l} P_2 = 1.6 \text{ MPa} \\ s_2 = s_1 \end{array} \right\} h_2 = 5083.4 \text{ kJ/kg}$$

$$\left. \begin{array}{l} P_3 = 1.6 \text{ MPa} \\ \text{sat. liquid} \end{array} \right\} h_3 = h_f @ 1.6 \text{ MPa} = 858.44 \text{ kJ/kg}$$

$$h_4 \cong h_3 = 858.44 \text{ kJ/kg} \quad (\text{throttling})$$

$$\left. \begin{array}{l} T_5 = -40^\circ\text{C} \\ \text{sat. vapor} \end{array} \right\} \begin{array}{l} h_5 = h_g @ -40^\circ\text{C} = 225.86 \text{ kJ/kg} \\ s_5 = s_g @ -40^\circ\text{C} = 0.96866 \text{ kJ/kg} \cdot \text{K} \end{array}$$

$$\left. \begin{array}{l} P_6 = 400 \text{ kPa} \\ s_6 = s_5 \end{array} \right\} h_6 = 267.59 \text{ kJ/kg}$$

$$\left. \begin{array}{l} P_7 = 400 \text{ kPa} \\ \text{sat. liquid} \end{array} \right\} h_7 = h_f @ 400 \text{ kPa} = 63.94 \text{ kJ/kg}$$

$$h_8 \cong h_7 = 63.94 \text{ kJ/kg} \quad (\text{throttling})$$

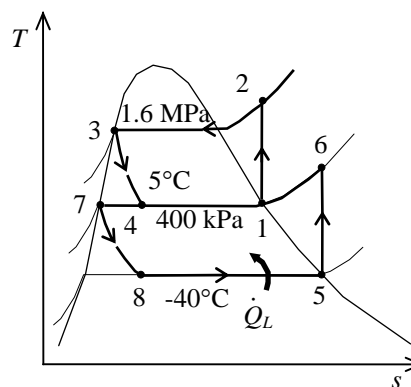

The mass flow rate of R-134a is determined from

$$\dot{Q}_L = \dot{m}_R (h_5 - h_8) \longrightarrow \dot{m}_R = \frac{\dot{Q}_L}{h_5 - h_8} = \frac{20 \text{ kJ/s}}{(225.86 - 63.94) \text{ kJ/kg}} = \mathbf{0.1235 \text{ kg/s}}$$

An energy balance on the heat exchanger gives the mass flow rate of water

$$\begin{aligned} \dot{m}_R (h_6 - h_7) &= \dot{m}_w (h_1 - h_4) \\ \longrightarrow \dot{m}_w &= \dot{m}_R \frac{h_6 - h_7}{h_1 - h_4} = (0.1235 \text{ kg/s}) \frac{267.59 - 63.94}{2510.1 - 858.44} = \mathbf{0.01523 \text{ kg/s}} \end{aligned}$$

The total power input to the compressors is

$$\begin{aligned} \dot{W}_{\text{in}} &= \dot{m}_R (h_6 - h_5) + \dot{m}_w (h_2 - h_1) \\ &= (0.1235 \text{ kg/s})(267.59 - 225.86) \text{ kJ/kg} + (0.01523 \text{ kg/s})(5083.4 - 2510.1) \text{ kJ/kg} \\ &= 44.35 \text{ kJ/s} \end{aligned}$$

The COP of this refrigeration system is determined from its definition,

$$\text{COP}_R = \frac{\dot{Q}_L}{\dot{W}_{\text{in}}} = \frac{20 \text{ kJ/s}}{44.35 \text{ kJ/s}} = \mathbf{0.451}$$

**11-56** A two-stage vapor-compression refrigeration system with refrigerant-134a as the working fluid is considered. The process with the greatest exergy destruction is to be determined.

**Assumptions 1** Steady operating conditions exist. **2** Kinetic and potential energy changes are negligible.

**Analysis** From Prob. 11-55 and the water and refrigerant tables (Tables A-4, A-5, A-6, A-11, A-12, and A-13),

$$\begin{aligned} s_1 &= s_2 = 9.0249 \text{ kJ/kg} \cdot \text{K} \\ s_3 &= 2.3435 \text{ kJ/kg} \cdot \text{K} \\ s_4 &= 3.0869 \text{ kJ/kg} \cdot \text{K} \\ s_5 &= s_6 = 0.96866 \text{ kJ/kg} \cdot \text{K} \\ s_7 &= 0.24757 \text{ kJ/kg} \cdot \text{K} \\ s_8 &= 0.27423 \text{ kJ/kg} \cdot \text{K} \\ \dot{m}_R &= 0.1235 \text{ kg/s} \\ \dot{m}_w &= 0.01751 \text{ kg/s} \\ q_L &= h_5 - h_8 = 161.92 \text{ kJ/kg} \\ q_H &= h_2 - h_3 = 4225.0 \text{ kJ/kg} \\ T_L &= -30^\circ\text{C} = 243 \text{ K} \\ T_H &= 30^\circ\text{C} = 303 \text{ K} \\ T_0 &= 30^\circ\text{C} = 303 \text{ K} \end{aligned}$$

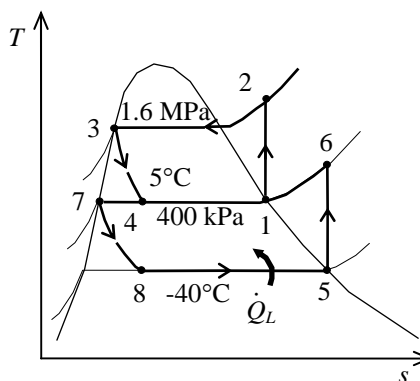

The exergy destruction during a process of a stream from an inlet state to exit state is given by

$$x_{\text{dest}} = T_0 s_{\text{gen}} = T_0 \left( s_e - s_i - \frac{q_{\text{in}}}{T_{\text{source}}} + \frac{q_{\text{out}}}{T_{\text{sink}}} \right)$$

Application of this equation for each process of the cycle gives

$$\begin{aligned} \dot{X}_{\text{destroyed},23} &= \dot{m}_w T_0 \left( s_3 - s_2 + \frac{q_H}{T_H} \right) \\ &= (0.01751)(303 \text{ K}) \left( 2.3435 - 9.0249 + \frac{4225.0}{303} \right) = 38.53 \text{ kJ/s} \end{aligned}$$

$$\dot{X}_{\text{destroyed},34} = \dot{m}_w T_0 (s_4 - s_3) = (0.01751)(303)(3.0869 - 2.3435) = 3.94 \text{ kJ/s}$$

$$\dot{X}_{\text{destroyed},78} = \dot{m}_R T_0 (s_8 - s_7) = (0.1235)(303)(0.27423 - 0.24757) = 1.00 \text{ kJ/s}$$

$$\begin{aligned} \dot{X}_{\text{destroyed},85} &= \dot{m}_R T_0 \left( s_5 - s_8 - \frac{q_L}{T_L} \right) \\ &= (0.1235)(303) \left( 0.96866 - 0.27423 - \frac{161.92}{243} \right) = 1.05 \text{ kJ/s} \end{aligned}$$

$$\begin{aligned} \dot{X}_{\text{destroyed, heat exch}} &= T_0 [\dot{m}_w (s_1 - s_4) + \dot{m}_R (s_7 - s_6)] \\ &= (303) [(0.01751)(9.0249 - 3.0869) + (0.1235)(0.24757 - 0.96866)] = 4.52 \text{ kJ/s} \end{aligned}$$

For isentropic processes, the exergy destruction is zero:

$$\dot{X}_{\text{destroyed},12} = 0$$

$$\dot{X}_{\text{destroyed},56} = 0$$

Note that heat is absorbed from a reservoir at  $-30^\circ\text{C}$  (243 K) and rejected to a reservoir at  $30^\circ\text{C}$  (303 K), which is also taken as the dead state temperature. Alternatively, one may use the standard  $25^\circ\text{C}$  (298 K) as the dead state temperature, and perform the calculations accordingly. The greatest exergy destruction occurs in the condenser.

## Gas Refrigeration Cycles

**11-57C** The ideal gas refrigeration cycle is identical to the Brayton cycle, except it operates in the reversed direction.

**11-58C** The reversed Stirling cycle is identical to the Stirling cycle, except it operates in the reversed direction. Remembering that the Stirling cycle is a totally reversible cycle, the reversed Stirling cycle is also totally reversible, and thus its COP is

$$\text{COP}_{\text{R,Stirling}} = \frac{1}{T_H / T_L - 1}$$

**11-59C** In the ideal gas refrigeration cycle, the heat absorption and the heat rejection processes occur at constant pressure instead of at constant temperature.

**11-60C** In aircraft cooling, the atmospheric air is compressed by a compressor, cooled by the surrounding air, and expanded in a turbine. The cool air leaving the turbine is then directly routed to the cabin.

**11-61C** No; because  $h = h(T)$  for ideal gases, and the temperature of air will not drop during a throttling ( $h_1 = h_2$ ) process.

**11-62C** By regeneration.

**11-63** [Also solved by EES on enclosed CD] An ideal-gas refrigeration cycle with air as the working fluid is considered. The rate of refrigeration, the net power input, and the COP are to be determined.

**Assumptions** 1 Steady operating conditions exist. 2 Air is an ideal gas with variable specific heats. 3 Kinetic and potential energy changes are negligible.

**Analysis** (a) We assume both the turbine and the compressor to be isentropic, the turbine inlet temperature to be the temperature of the surroundings, and the compressor inlet temperature to be the temperature of the refrigerated space. From the air table (Table A-17),

$$T_1 = 285 \text{ K} \longrightarrow \begin{aligned} h_1 &= 285.14 \text{ kJ/kg} \\ P_{r_1} &= 1.1584 \end{aligned}$$

$$T_1 = 320 \text{ K} \longrightarrow \begin{aligned} h_3 &= 320.29 \text{ kJ/kg} \\ P_{r_3} &= 1.7375 \end{aligned}$$

Thus,

$$P_{r_2} = \frac{P_2}{P_1} P_{r_1} = \left( \frac{250}{50} \right) (1.1584) = 5.792 \longrightarrow \begin{aligned} T_2 &= 450.4 \text{ K} \\ h_2 &= 452.17 \text{ kJ/kg} \end{aligned}$$

$$P_{r_4} = \frac{P_4}{P_3} P_{r_3} = \left( \frac{50}{250} \right) (1.7375) = 0.3475 \longrightarrow \begin{aligned} T_4 &= 201.8 \text{ K} \\ h_4 &= 201.76 \text{ kJ/kg} \end{aligned}$$

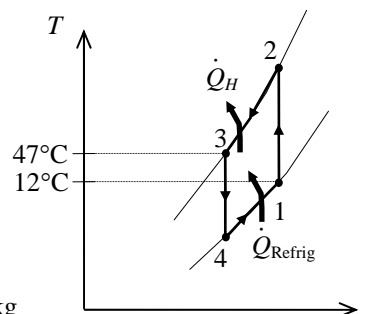

Then the rate of refrigeration is

$$\dot{Q}_{\text{refrig}} = \dot{m}(q_L) = \dot{m}(h_1 - h_4) = (0.08 \text{ kg/s})(285.14 - 201.76) \text{ kJ/kg} = \mathbf{6.67 \text{ kW}}$$

(b) The net power input is determined from

$$\dot{W}_{\text{net, in}} = \dot{W}_{\text{comp, in}} - \dot{W}_{\text{turb, out}}$$

where

$$\dot{W}_{\text{comp, in}} = \dot{m}(h_2 - h_1) = (0.08 \text{ kg/s})(452.17 - 285.14) \text{ kJ/kg} = 13.36 \text{ kW}$$

$$\dot{W}_{\text{turb, out}} = \dot{m}(h_3 - h_4) = (0.08 \text{ kg/s})(320.29 - 201.76) \text{ kJ/kg} = 9.48 \text{ kW}$$

Thus,

$$\dot{W}_{\text{net, in}} = 13.36 - 9.48 = \mathbf{3.88 \text{ kW}}$$

(c) The COP of this ideal gas refrigeration cycle is determined from

$$\text{COP}_R = \frac{\dot{Q}_L}{\dot{W}_{\text{net, in}}} = \frac{6.67 \text{ kW}}{3.88 \text{ kW}} = \mathbf{1.72}$$

**11-64 EES** Problem 11-63 is reconsidered. The effects of compressor and turbine isentropic efficiencies on the rate of refrigeration, the net power input, and the COP are to be investigated.

**Analysis** The problem is solved using EES, and the solution is given below.

"Input data"

T[1] = 12 [C]  
 P[1] = 50 [kPa]  
 T[3] = 47 [C]  
 P[3] = 250 [kPa]  
 m\_dot = 0.08 [kg/s]  
 Eta\_comp = 1.00  
 Eta\_turb = 1.0

"Compressor analysis"

s[1] = ENTROPY(Air, T=T[1], P=P[1])  
 s2s = s[1] "For the ideal case the entropies are constant across the compressor"  
 P[2] = P[3]  
 s2s = ENTROPY(Air, T=Ts2, P=P[2]) "Ts2 is the isentropic value of T[2] at compressor exit"  
 Eta\_comp = W\_dot\_comp\_isen / W\_dot\_comp "compressor adiabatic efficiency, W\_dot\_comp > W\_dot\_comp\_isen"  
 m\_dot\*h[1] + W\_dot\_comp\_isen = m\_dot\*hs2 "SSSF First Law for the isentropic compressor, assuming: adiabatic, ke=pe=0, m\_dot is the mass flow rate in kg/s"  
 h[1] = ENTHALPY(Air, T=T[1])  
 hs2 = ENTHALPY(Air, T=Ts2)  
 m\_dot\*h[1] + W\_dot\_comp = m\_dot\*h[2] "SSSF First Law for the actual compressor, assuming: adiabatic, ke=pe=0"  
 h[2] = ENTHALPY(Air, T=T[2])  
 s[2] = ENTROPY(Air, h=h[2], P=P[2])

"Heat Rejection Process 2-3, assumed SSSF constant pressure process"

m\_dot\*h[2] + Q\_dot\_out = m\_dot\*h[3] "SSSF First Law for the heat exchanger, assuming W=0, ke=pe=0"  
 h[3] = ENTHALPY(Air, T=T[3])

"Turbine analysis"

s[3] = ENTROPY(Air, T=T[3], P=P[3])  
 s4s = s[3] "For the ideal case the entropies are constant across the turbine"  
 P[4] = P[1]  
 s4s = ENTROPY(Air, T=Ts4, P=P[4]) "Ts4 is the isentropic value of T[4] at turbine exit"  
 Eta\_turb = W\_dot\_turb / W\_dot\_turb\_isen "turbine adiabatic efficiency, W\_dot\_turb\_isen > W\_dot\_turb"  
 m\_dot\*h[3] = W\_dot\_turb\_isen + m\_dot\*hs4 "SSSF First Law for the isentropic turbine, assuming: adiabatic, ke=pe=0"  
 hs4 = ENTHALPY(Air, T=Ts4)  
 m\_dot\*h[3] = W\_dot\_turb + m\_dot\*h[4] "SSSF First Law for the actual compressor, assuming: adiabatic, ke=pe=0"  
 h[4] = ENTHALPY(Air, T=T[4])  
 s[4] = ENTROPY(Air, h=h[4], P=P[4])

"Refrigeration effect:"

m\_dot\*h[4] + Q\_dot\_Refrig = m\_dot\*h[1]

"Cycle analysis"

W\_dot\_in\_net = W\_dot\_comp - W\_dot\_turb "External work supplied to compressor"  
 COP = Q\_dot\_Refrig / W\_dot\_in\_net

"The following is for plotting data only:"

Ts[1] = Ts2  
 ss[1] = s2s  
 Ts[2] = Ts4  
 ss[2] = s4s

COP	$\eta_{\text{comp}}$	$\eta_{\text{turb}}$	$\dot{Q}_{\text{Refrig}}$ [kW]	$\dot{W}_{\text{innet}}$ [kW]
0.6937	0.7	1	6.667	9.612
0.9229	0.8	1	6.667	7.224
1.242	0.9	1	6.667	5.368
1.717	1	1	6.667	3.882

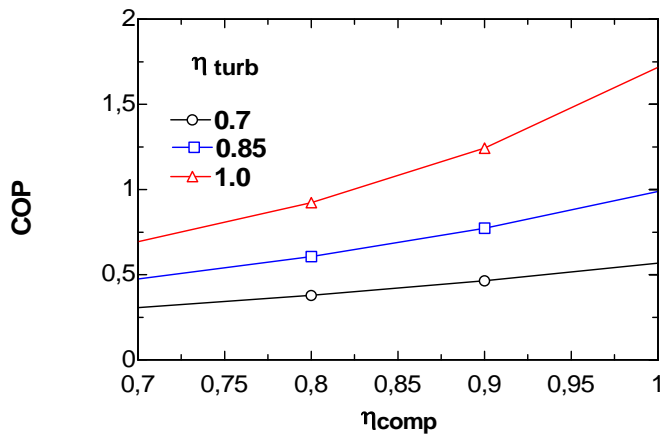
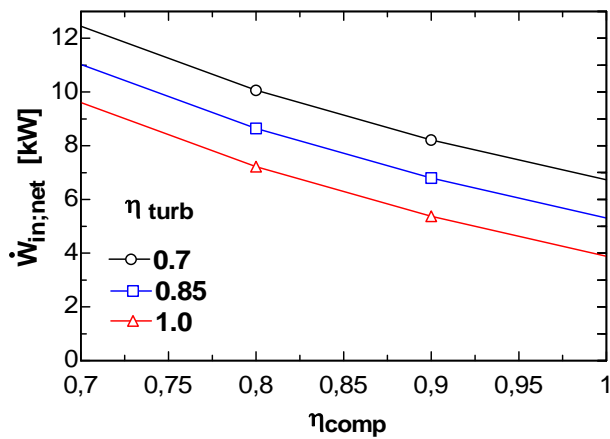
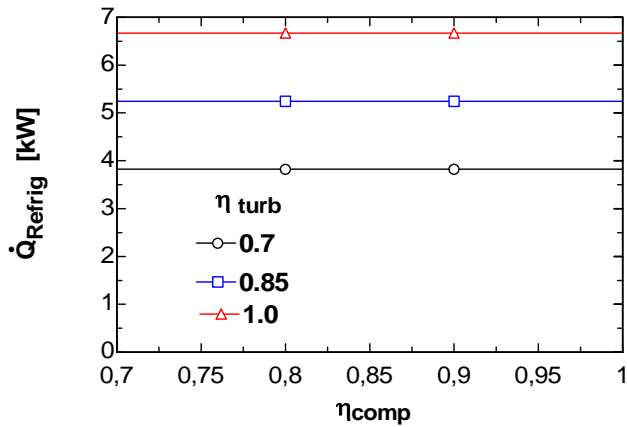

**11-65** [Also solved by EES on enclosed CD] An ideal-gas refrigeration cycle with air as the working fluid is considered. The rate of refrigeration, the net power input, and the COP are to be determined.

**Assumptions 1** Steady operating conditions exist. **2** Air is an ideal gas with variable specific heats. **3** Kinetic and potential energy changes are negligible.

**Analysis (a)** We assume the turbine inlet temperature to be the temperature of the surroundings, and the compressor inlet temperature to be the temperature of the refrigerated space. From the air table (Table A-17),

$$T_1 = 285 \text{ K} \longrightarrow \begin{aligned} h_1 &= 285.14 \text{ kJ/kg} \\ P_{r_1} &= 1.1584 \end{aligned}$$

$$T_3 = 320 \text{ K} \longrightarrow \begin{aligned} h_3 &= 320.29 \text{ kJ/kg} \\ P_{r_3} &= 1.7375 \end{aligned}$$

Thus,

$$P_{r_2} = \frac{P_2}{P_1} P_{r_1} = \left( \frac{250}{50} \right) (1.1584) = 5.792 \longrightarrow \begin{aligned} T_{2s} &= 450.4 \text{ K} \\ h_{2s} &= 452.17 \text{ kJ/kg} \end{aligned}$$

$$P_{r_4} = \frac{P_4}{P_3} P_{r_3} = \left( \frac{50}{250} \right) (1.7375) = 0.3475 \longrightarrow \begin{aligned} T_{4s} &= 201.8 \text{ K} \\ h_{4s} &= 201.76 \text{ kJ/kg} \end{aligned}$$

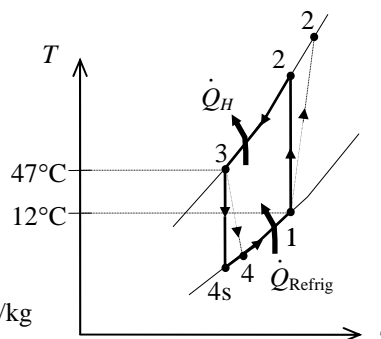

Also,

$$\begin{aligned} \eta_T = \frac{h_3 - h_4}{h_3 - h_{4s}} &\longrightarrow h_4 = h_3 - \eta_T (h_3 - h_{4s}) \\ &= 320.29 - (0.85)(320.29 - 201.76) \\ &= 219.54 \text{ kJ/kg} \end{aligned}$$

Then the rate of refrigeration is

$$\dot{Q}_{\text{refrig}} = \dot{m}(q_L) = \dot{m}(h_1 - h_4) = (0.08 \text{ kg/s})(285.14 - 219.54) \text{ kJ/kg} = \mathbf{5.25 \text{ kW}}$$

(b) The net power input is determined from

$$\dot{W}_{\text{net, in}} = \dot{W}_{\text{comp, in}} - \dot{W}_{\text{turb, out}}$$

where

$$\begin{aligned} \dot{W}_{\text{comp, in}} &= \dot{m}(h_2 - h_1) = \dot{m}(h_{2s} - h_1) / \eta_C \\ &= (0.08 \text{ kg/s})[(452.17 - 285.14) \text{ kJ/kg}] / (0.80) = 16.70 \text{ kW} \end{aligned}$$

$$\dot{W}_{\text{turb, out}} = \dot{m}(h_3 - h_4) = (0.08 \text{ kg/s})(320.29 - 219.54) \text{ kJ/kg} = 8.06 \text{ kW}$$

Thus,

$$\dot{W}_{\text{net, in}} = 16.70 - 8.06 = \mathbf{8.64 \text{ kW}}$$

(c) The COP of this ideal gas refrigeration cycle is determined from

$$\text{COP}_R = \frac{\dot{Q}_L}{\dot{W}_{\text{net, in}}} = \frac{5.25 \text{ kW}}{8.64 \text{ kW}} = \mathbf{0.61}$$



**11-66** A gas refrigeration cycle with helium as the working fluid is considered. The minimum temperature in the cycle, the COP, and the mass flow rate of the helium are to be determined.

**Assumptions 1** Steady operating conditions exist. **2** Helium is an ideal gas with constant specific heats. **3** Kinetic and potential energy changes are negligible.

**Properties** The properties of helium are  $c_p = 5.1926 \text{ kJ/kg}\cdot\text{K}$  and  $k = 1.667$  (Table A-2).

**Analysis (a)** From the isentropic relations,

$$T_{2s} = T_1 \left( \frac{P_2}{P_1} \right)^{(k-1)/k} = (263\text{K})(3)^{0.667/1.667} = 408.2\text{K}$$

$$T_{4s} = T_3 \left( \frac{P_4}{P_3} \right)^{(k-1)/k} = (323\text{K}) \left( \frac{1}{3} \right)^{0.667/1.667} = 208.1\text{K}$$

and

$$\eta_T = \frac{h_3 - h_4}{h_3 - h_{4s}} = \frac{T_3 - T_4}{T_3 - T_{4s}} \longrightarrow T_4 = T_3 - \eta_T (T_3 - T_{4s}) = 323 - (0.80)(323 - 208.1) = 231.1 \text{ K} = T_{\min}$$

$$\eta_C = \frac{h_{2s} - h_1}{h_2 - h_1} = \frac{T_{2s} - T_1}{T_2 - T_1} \longrightarrow T_2 = T_1 + (T_{2s} - T_1)/\eta_C = 263 + (408.2 - 263)/(0.80) = 444.5 \text{ K}$$

(b) The COP of this gas refrigeration cycle is determined from

$$\begin{aligned} \text{COP}_R &= \frac{q_L}{w_{\text{net,in}}} = \frac{q_L}{w_{\text{comp,in}} - w_{\text{turb,out}}} \\ &= \frac{h_1 - h_4}{(h_2 - h_1) - (h_3 - h_4)} \\ &= \frac{T_1 - T_4}{(T_2 - T_1) - (T_3 - T_4)} \\ &= \frac{263 - 231.1}{(444.5 - 263) - (323 - 231.1)} = \mathbf{0.356} \end{aligned}$$

(c) The mass flow rate of helium is determined from

$$\dot{m} = \frac{\dot{Q}_{\text{refrig}}}{q_L} = \frac{\dot{Q}_{\text{refrig}}}{h_1 - h_4} = \frac{\dot{Q}_{\text{refrig}}}{c_p (T_1 - T_4)} = \frac{18 \text{ kJ/s}}{(5.1926 \text{ kJ/kg}\cdot\text{K})(263 - 231.1)\text{K}} = \mathbf{0.109 \text{ kg/s}}$$

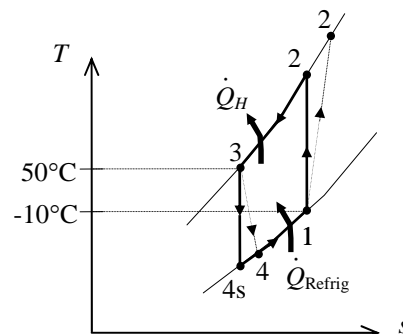

**11-67** A regenerative gas refrigeration cycle using air as the working fluid is considered. The effectiveness of the regenerator, the rate of heat removal from the refrigerated space, the COP of the cycle, and the refrigeration load and the COP if this system operated on the simple gas refrigeration cycle are to be determined.

**Assumptions** 1 Steady operating conditions exist. 2 Kinetic and potential energy changes are negligible. 3 Air is an ideal gas with constant specific heats.

**Properties** The properties of air at room temperature are  $c_p = 1.005 \text{ kJ/kg}\cdot\text{K}$  and  $k = 1.4$  (Table A-2).

**Analysis** (a) From the isentropic relations,

$$T_{2s} = T_1 \left( \frac{P_2}{P_1} \right)^{(k-1)/k} = (273.2 \text{ K})(5)^{0.4/1.4} = 432.4 \text{ K}$$

$$\eta_C = \frac{h_{2s} - h_1}{h_2 - h_1} = \frac{T_{2s} - T_1}{T_2 - T_1}$$

$$0.80 = \frac{432.4 - 273.2}{T_2 - 273.2} \rightarrow T_2 = 472.5 \text{ K}$$

The temperature at state 4 can be determined by solving the following two equations simultaneously:

$$T_{5s} = T_4 \left( \frac{P_5}{P_4} \right)^{(k-1)/k} = T_4 \left( \frac{1}{5} \right)^{0.4/1.4}$$

$$\eta_T = \frac{h_4 - h_5}{h_4 - h_{5s}} \rightarrow 0.85 = \frac{T_4 - 193.2}{T_4 - T_{5s}}$$

Using EES, we obtain  $T_4 = 281.3 \text{ K}$ .

An energy balance on the regenerator may be written as

$$\dot{m}c_p(T_3 - T_4) = \dot{m}c_p(T_1 - T_6) \rightarrow T_3 - T_4 = T_1 - T_6$$

or,

$$T_6 = T_1 - T_3 + T_4 = 273.2 - 308.2 + 281.3 = 246.3 \text{ K}$$

The effectiveness of the regenerator is

$$\varepsilon_{\text{regen}} = \frac{h_3 - h_4}{h_3 - h_6} = \frac{T_3 - T_4}{T_3 - T_6} = \frac{308.2 - 281.3}{308.2 - 246.3} = \mathbf{0.434}$$

(b) The refrigeration load is

$$\dot{Q}_L = \dot{m}c_p(T_6 - T_5) = (0.4 \text{ kg/s})(1.005 \text{ kJ/kg}\cdot\text{K})(246.3 - 193.2)\text{K} = \mathbf{21.36 \text{ kW}}$$

(c) The turbine and compressor powers and the COP of the cycle are

$$\dot{W}_{\text{C,in}} = \dot{m}c_p(T_2 - T_1) = (0.4 \text{ kg/s})(1.005 \text{ kJ/kg}\cdot\text{K})(472.5 - 273.2)\text{K} = 80.13 \text{ kW}$$

$$\dot{W}_{\text{T,out}} = \dot{m}c_p(T_4 - T_5) = (0.4 \text{ kg/s})(1.005 \text{ kJ/kg}\cdot\text{K})(281.3 - 193.2)\text{kJ/kg} = 35.43 \text{ kW}$$

$$\text{COP} = \frac{\dot{Q}_L}{\dot{W}_{\text{net,in}}} = \frac{\dot{Q}_L}{\dot{W}_{\text{C,in}} - \dot{W}_{\text{T,out}}} = \frac{21.36}{80.13 - 35.43} = \mathbf{0.478}$$

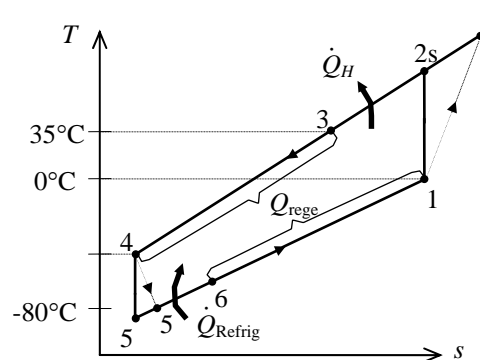
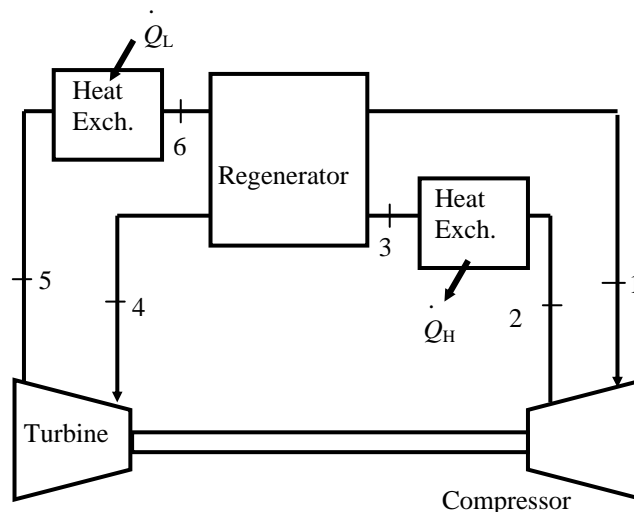

(d) The simple gas refrigeration cycle analysis is as follows:

$$T_{4s} = T_3 \left( \frac{1}{r} \right)^{(k-1)/k} = (308.2 \text{ K}) \left( \frac{1}{5} \right)^{0.4/1.4} = 194.6 \text{ K}$$

$$\eta_T = \frac{T_3 - T_4}{T_3 - T_{4s}} \rightarrow 0.85 = \frac{308.2 - T_4}{308.2 - 194.6} \rightarrow T_4 = 211.6 \text{ K}$$

$$\begin{aligned} \dot{Q}_L &= \dot{m} c_p (T_1 - T_4) \\ &= (0.4 \text{ kg/s})(1.005 \text{ kJ/kg}\cdot\text{K})(273.2 - 211.6) \text{ kJ/kg} \\ &= \mathbf{24.74 \text{ kW}} \end{aligned}$$

$$\begin{aligned} \dot{W}_{\text{net,in}} &= \dot{m} c_p (T_2 - T_1) - \dot{m} c_p (T_3 - T_4) \\ &= (0.4 \text{ kg/s})(1.005 \text{ kJ/kg}\cdot\text{K})[(472.5 - 273.2) - (308.2 - 211.6) \text{ kJ/kg}] \\ &= 41.32 \text{ kW} \end{aligned}$$

$$\text{COP} = \frac{\dot{Q}_L}{\dot{W}_{\text{net,in}}} = \frac{24.74}{41.32} = \mathbf{0.599}$$

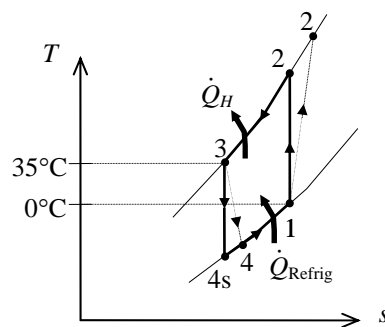

**11-68E** An ideal gas refrigeration cycle with air as the working fluid has a compression ratio of 4. The COP of the cycle is to be determined.

**Assumptions** 1 Steady operating conditions exist. 2 Air is an ideal gas with constant specific heats. 3 Kinetic and potential energy changes are negligible.

**Properties** The properties of air at room temperature are  $c_p = 0.240$  Btu/lbm·R and  $k = 1.4$  (Table A-2Ea).

**Analysis** From the isentropic relations,

$$T_2 = T_1 \left( \frac{P_2}{P_1} \right)^{(k-1)/k} = (450 \text{ R})(4)^{0.4/1.4} = 668.7 \text{ R}$$

$$T_4 = T_3 \left( \frac{P_4}{P_3} \right)^{(k-1)/k} = (560 \text{ R}) \left( \frac{1}{4} \right)^{0.4/1.4} = 376.8 \text{ R}$$

The COP of this ideal gas refrigeration cycle is determined from

$$\begin{aligned} \text{COP}_R &= \frac{q_L}{w_{\text{net,in}}} = \frac{q_L}{w_{\text{comp,in}} - w_{\text{turb,out}}} \\ &= \frac{h_1 - h_4}{(h_2 - h_1) - (h_3 - h_4)} \\ &= \frac{T_1 - T_4}{(T_2 - T_1) - (T_3 - T_4)} \\ &= \frac{450 - 376.8}{(668.7 - 450) - (560 - 376.8)} = \mathbf{2.06} \end{aligned}$$

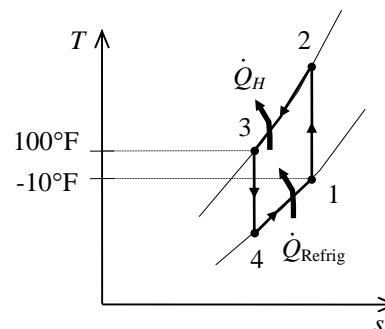

**11-69E** An gas refrigeration cycle with air as the working fluid has a compression ratio of 4. The COP of the cycle is to be determined.

**Assumptions 1** Steady operating conditions exist. **2** Air is an ideal gas with constant specific heats. **3** Kinetic and potential energy changes are negligible.

**Properties** The properties of air at room temperature are  $c_p = 0.240$  Btu/lbm-R and  $k = 1.4$  (Table A-2Ea).

**Analysis** From the isentropic relations,

$$T_{2s} = T_1 \left( \frac{P_2}{P_1} \right)^{(k-1)/k} = (450 \text{ R})(4)^{0.4/1.4} = 668.7 \text{ R}$$

$$T_{4s} = T_3 \left( \frac{P_4}{P_3} \right)^{(k-1)/k} = (560 \text{ R}) \left( \frac{6 \text{ psia}}{19 \text{ psia}} \right)^{0.4/1.4} = 402.9 \text{ R}$$

and

$$\eta_T = \frac{h_3 - h_4}{h_3 - h_{4s}} = \frac{T_3 - T_4}{T_3 - T_{4s}} \longrightarrow T_4 = T_3 - \eta_T (T_3 - T_{4s}) = 560 - (0.94)(560 - 402.9) = 412.3 \text{ R}$$

$$\eta_C = \frac{h_{2s} - h_1}{h_2 - h_1} = \frac{T_{2s} - T_1}{T_2 - T_1} \longrightarrow T_2 = T_1 + (T_{2s} - T_1) / \eta_C = 450 + (668.7 - 450) / (0.87) = 701.4 \text{ R}$$

The COP of this gas refrigeration cycle is determined from

$$\begin{aligned} \text{COP}_R &= \frac{q_L}{w_{\text{net,in}}} = \frac{q_L}{w_{\text{comp,in}} - w_{\text{turb,out}}} \\ &= \frac{h_1 - h_4}{(h_2 - h_1) - (h_3 - h_4)} \\ &= \frac{T_1 - T_4}{(T_2 - T_1) - (T_3 - T_4)} \\ &= \frac{450 - 412.3}{(701.4 - 450) - (560 - 412.3)} = \mathbf{0.364} \end{aligned}$$

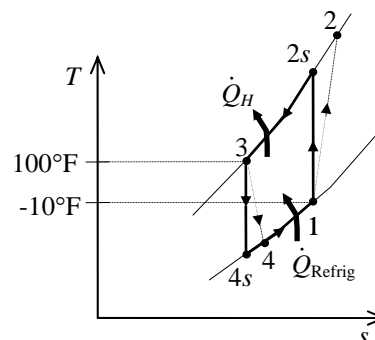

**11-70** An ideal gas refrigeration cycle with air as the working fluid provides 15 kW of cooling. The mass flow rate of air and the rates of heat addition and rejection are to be determined.

**Assumptions** 1 Steady operating conditions exist. 2 Air is an ideal gas with constant specific heats. 3 Kinetic and potential energy changes are negligible.

**Properties** The properties of air at room temperature are  $c_p = 1.005 \text{ kJ/kg}\cdot\text{K}$  and  $k = 1.4$  (Table A-2a).

**Analysis** From the isentropic relations,

$$T_2 = T_1 \left( \frac{P_2}{P_1} \right)^{(k-1)/k} = (293 \text{ K}) \left( \frac{500 \text{ kPa}}{100 \text{ kPa}} \right)^{0.4/1.4} = 464.1 \text{ K}$$

$$T_4 = T_3 \left( \frac{P_4}{P_3} \right)^{(k-1)/k} = (303 \text{ K}) \left( \frac{100 \text{ kPa}}{500 \text{ kPa}} \right)^{0.4/1.4} = 191.3 \text{ K}$$

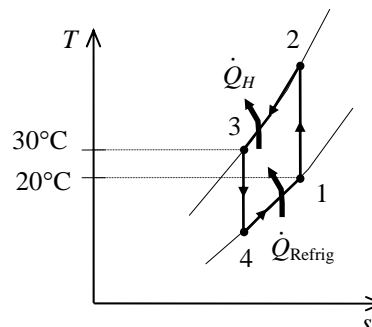

The mass flow rate of the air is determined from

$$\dot{Q}_{\text{Refrig}} = \dot{m} c_p (T_1 - T_4) \longrightarrow \dot{m} = \frac{\dot{Q}_{\text{Refrig}}}{c_p (T_1 - T_4)} = \frac{15 \text{ kJ/s}}{(1.005 \text{ kJ/kg}\cdot\text{K})(293 - 191.3) \text{ K}} = \mathbf{0.1468 \text{ kg/s}}$$

The rate of heat addition to the cycle is the same as the rate of cooling,

$$\dot{Q}_{\text{in}} = \dot{Q}_{\text{Refrig}} = \mathbf{15 \text{ kW}}$$

The rate of heat rejection from the cycle is

$$\dot{Q}_H = \dot{m} c_p (T_2 - T_3) = (0.1468 \text{ kg/s})(1.005 \text{ kJ/kg}\cdot\text{K})(464.1 - 303) \text{ K} = \mathbf{23.8 \text{ kW}}$$

**11-71** An ideal gas refrigeration cycle with air as the working fluid is considered. The minimum pressure ratio for this system to operate properly is to be determined.

**Assumptions** 1 Steady operating conditions exist. 2 Air is an ideal gas with constant specific heats. 3 Kinetic and potential energy changes are negligible.

**Properties** The properties of air at room temperature are  $c_p = 1.005 \text{ kJ/kg}\cdot\text{K}$  and  $k = 1.4$  (Table A-2a).

**Analysis** An energy balance on process 4-1 gives

$$q_{\text{Refrig}} = c_p(T_1 - T_4)$$

$$T_4 = T_1 - \frac{q_{\text{Refrig}}}{c_p} = 268 \text{ K} - \frac{20 \text{ kJ/kg}}{1.005 \text{ kJ/kg}\cdot\text{K}} = 248.1 \text{ K}$$

The minimum temperature at the turbine inlet would be the same as that to which the heat is rejected. That is,

$$T_3 = 293 \text{ K}$$

Then the minimum pressure ratio is determined from the isentropic relation to be

$$\frac{P_3}{P_4} = \left(\frac{T_3}{T_4}\right)^{k/(k-1)} = \left(\frac{293 \text{ K}}{248.1 \text{ K}}\right)^{1.4/0.4} = \mathbf{1.79}$$

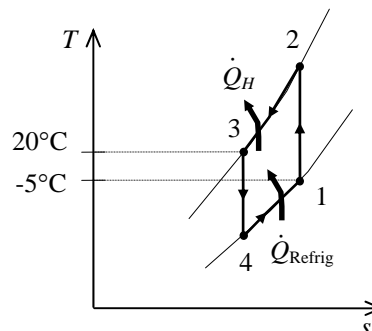

**11-72** An ideal gas refrigeration cycle with two stages of compression with intercooling using air as the working fluid is considered. The COP of this system and the mass flow rate of air are to be determined.

**Assumptions** 1 Steady operating conditions exist. 2 Air is an ideal gas with constant specific heats. 3 Kinetic and potential energy changes are negligible.

**Properties** The properties of air at room temperature are  $c_p = 1.005 \text{ kJ/kg}\cdot\text{K}$  and  $k = 1.4$  (Table A-2a).

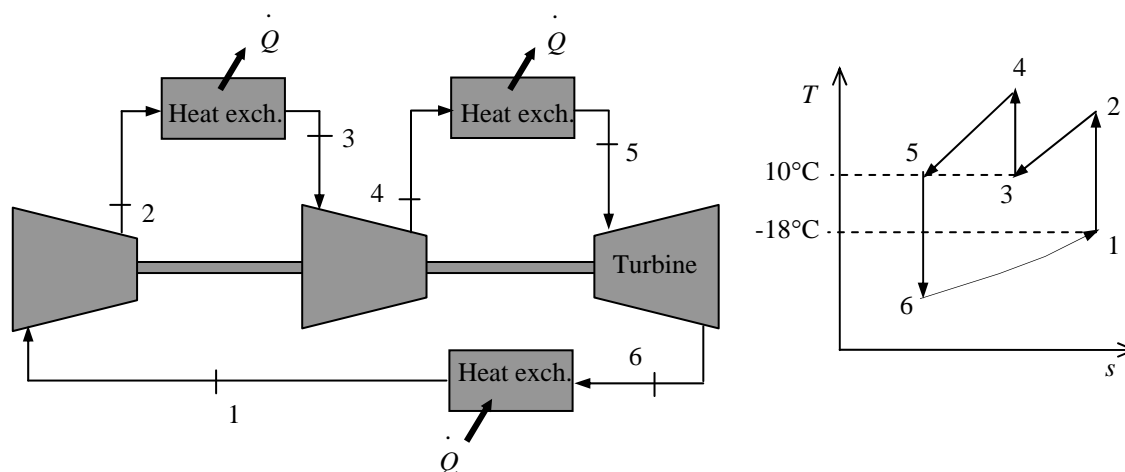

**Analysis** From the isentropic relations,

$$T_2 = T_1 \left( \frac{P_2}{P_1} \right)^{(k-1)/k} = (255 \text{ K})(4)^{0.4/1.4} = 378.9 \text{ K}$$

$$T_4 = T_3 \left( \frac{P_4}{P_3} \right)^{(k-1)/k} = (283 \text{ K})(4)^{0.4/1.4} = 420.5 \text{ K}$$

$$T_6 = T_5 \left( \frac{P_6}{P_5} \right)^{(k-1)/k} = (283 \text{ K}) \left( \frac{1}{16} \right)^{0.4/1.4} = 128.2 \text{ K}$$

The COP of this ideal gas refrigeration cycle is determined from

$$\begin{aligned} \text{COP}_R &= \frac{q_L}{w_{\text{net,in}}} = \frac{q_L}{w_{\text{comp,in}} - w_{\text{turb,out}}} \\ &= \frac{h_1 - h_6}{(h_2 - h_1) + (h_4 - h_3) - (h_5 - h_6)} \\ &= \frac{T_1 - T_6}{(T_2 - T_1) + (T_4 - T_3) - (T_5 - T_6)} \\ &= \frac{255 - 128.2}{(378.9 - 255) + (420.5 - 283) - (283 - 128.2)} = \mathbf{1.19} \end{aligned}$$

The mass flow rate of the air is determined from

$$\dot{Q}_{\text{Refrig}} = \dot{m} c_p (T_1 - T_6) \longrightarrow \dot{m} = \frac{\dot{Q}_{\text{Refrig}}}{c_p (T_1 - T_6)} = \frac{(75,000 / 3600) \text{ kJ/s}}{(1.005 \text{ kJ/kg}\cdot\text{K})(255 - 128.2) \text{ K}} = \mathbf{0.163 \text{ kg/s}}$$



**11-73** A gas refrigeration cycle with two stages of compression with intercooling using air as the working fluid is considered. The COP of this system and the mass flow rate of air are to be determined.  
*Assumptions* 1 Steady operating conditions exist. 2 Air is an ideal gas with constant specific heats. 3 Kinetic and potential energy changes are negligible.  
*Properties* The properties of air at room temperature are  $c_p = 1.005 \text{ kJ/kg}\cdot\text{K}$  and  $k = 1.4$  (Table A-2a).

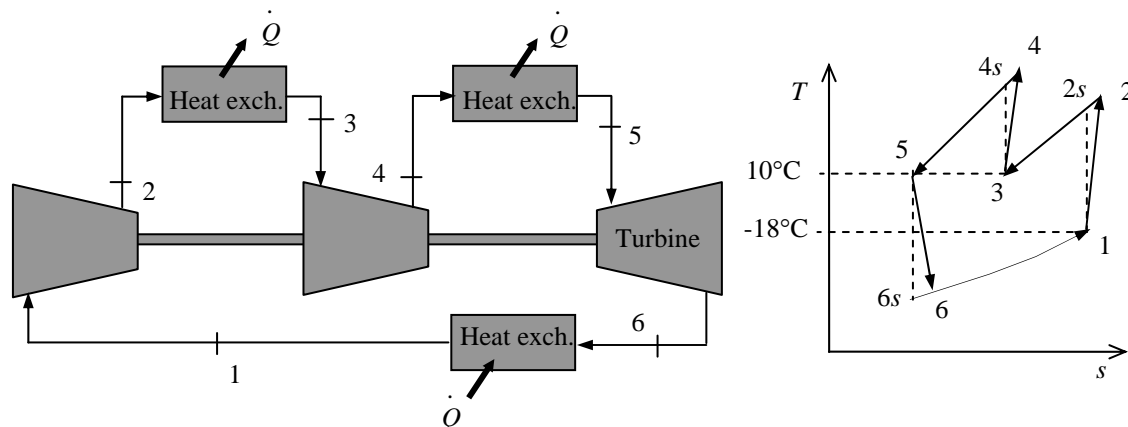

**Analysis** From the isentropic relations,

$$T_{2s} = T_1 \left( \frac{P_2}{P_1} \right)^{(k-1)/k} = (255 \text{ K})(4)^{0.4/1.4} = 378.9 \text{ K}$$

$$T_{4s} = T_3 \left( \frac{P_4}{P_3} \right)^{(k-1)/k} = (283 \text{ K})(4)^{0.4/1.4} = 420.5 \text{ K}$$

$$T_{6s} = T_5 \left( \frac{P_6}{P_5} \right)^{(k-1)/k} = (283 \text{ K}) \left( \frac{1}{16} \right)^{0.4/1.4} = 128.2 \text{ K}$$

and

$$\eta_C = \frac{h_{2s} - h_1}{h_2 - h_1} = \frac{T_{2s} - T_1}{T_2 - T_1} \longrightarrow T_2 = T_1 + (T_{2s} - T_1) / \eta_C = 255 + (378.9 - 255) / 0.85 = 400.8 \text{ K}$$

$$\eta_C = \frac{h_{4s} - h_3}{h_4 - h_3} = \frac{T_{4s} - T_3}{T_4 - T_3} \longrightarrow T_4 = T_3 + (T_{4s} - T_3) / \eta_C = 283 + (420.5 - 283) / 0.85 = 444.8 \text{ K}$$

$$\eta_T = \frac{h_5 - h_6}{h_5 - h_{6s}} = \frac{T_5 - T_6}{T_5 - T_{6s}} \longrightarrow T_6 = T_5 - \eta_T (T_5 - T_{6s}) = 283 - (0.95)(283 - 128.2) = 135.9 \text{ K}$$

The COP of this ideal gas refrigeration cycle is determined from

$$\begin{aligned} \text{COP}_R &= \frac{q_L}{w_{\text{net,in}} - w_{\text{turb,out}}} = \frac{q_L}{w_{\text{comp,in}} - w_{\text{turb,out}}} \\ &= \frac{h_1 - h_6}{(h_2 - h_1) + (h_4 - h_3) - (h_5 - h_6)} \\ &= \frac{T_1 - T_6}{(T_2 - T_1) + (T_4 - T_3) - (T_5 - T_6)} \\ &= \frac{255 - 135.9}{(400.8 - 255) + (444.8 - 283) - (283 - 135.9)} = \mathbf{0.742} \end{aligned}$$

The mass flow rate of the air is determined from

$$\dot{Q}_{\text{Refrig}} = \dot{m} c_p (T_1 - T_6) \longrightarrow \dot{m} = \frac{\dot{Q}_{\text{Refrig}}}{c_p (T_1 - T_6)} = \frac{(75,000 / 3600) \text{ kJ/s}}{(1.005 \text{ kJ/kg}\cdot\text{K})(255 - 135.9) \text{ K}} = \mathbf{0.174 \text{ kg/s}}$$

## Absorption Refrigeration Systems

**11-74C** Absorption refrigeration is the kind of refrigeration that involves the absorption of the refrigerant during part of the cycle. In absorption refrigeration cycles, the refrigerant is compressed in the liquid phase instead of in the vapor form.

**11-75C** The main advantage of absorption refrigeration is its being economical in the presence of an inexpensive heat source. Its disadvantages include being expensive, complex, and requiring an external heat source.

**11-76C** In absorption refrigeration, water can be used as the refrigerant in air conditioning applications since the temperature of water never needs to fall below the freezing point.

**11-77C** The fluid in the absorber is cooled to maximize the refrigerant content of the liquid; the fluid in the generator is heated to maximize the refrigerant content of the vapor.

**11-78C** The coefficient of performance of absorption refrigeration systems is defined as

$$\text{COP}_R = \frac{\text{desired output}}{\text{required input}} = \frac{Q_L}{Q_{\text{gen}} + W_{\text{pump,in}}} \cong \frac{Q_L}{Q_{\text{gen}}}$$

**11-79C** The rectifier separates the water from  $\text{NH}_3$  and returns it to the generator. The regenerator transfers some heat from the water-rich solution leaving the generator to the  $\text{NH}_3$ -rich solution leaving the pump.

**11-80** The COP of an absorption refrigeration system that operates at specified conditions is given. It is to be determined whether the given COP value is possible.

**Analysis** The maximum COP that this refrigeration system can have is

$$\text{COP}_{\text{R,max}} = \left(1 - \frac{T_0}{T_s}\right) \left(\frac{T_L}{T_0 - T_L}\right) = \left(1 - \frac{300 \text{ K}}{403 \text{ K}}\right) \left(\frac{268}{300 - 268}\right) = 2.14$$

which is slightly greater than 2. Thus the claim is **possible**, but not probable.

**11-81** The conditions at which an absorption refrigeration system operates are specified. The maximum COP this absorption refrigeration system can have is to be determined.

**Analysis** The maximum COP that this refrigeration system can have is

$$\text{COP}_{\text{R,max}} = \left(1 - \frac{T_0}{T_s}\right) \left(\frac{T_L}{T_0 - T_L}\right) = \left(1 - \frac{298 \text{ K}}{393 \text{ K}}\right) \left(\frac{273}{298 - 273}\right) = \mathbf{2.64}$$

**11-82** The conditions at which an absorption refrigeration system operates are specified. The maximum rate at which this system can remove heat from the refrigerated space is to be determined.

**Analysis** The maximum COP that this refrigeration system can have is

$$\text{COP}_{\text{R,max}} = \left(1 - \frac{T_0}{T_s}\right) \left(\frac{T_L}{T_0 - T_L}\right) = \left(1 - \frac{298 \text{ K}}{403 \text{ K}}\right) \left(\frac{243}{298 - 243}\right) = 1.15$$

Thus,

$$\dot{Q}_{\text{L,max}} = \text{COP}_{\text{R,max}} \dot{Q}_{\text{gen}} = (1.15)(5 \times 10^5 \text{ kJ/h}) = \mathbf{5.75 \times 10^5 \text{ kJ/h}}$$

**11-83E** The conditions at which an absorption refrigeration system operates are specified. The COP is also given. The maximum rate at which this system can remove heat from the refrigerated space is to be determined.

**Analysis** For a COP = 0.55, the rate at which this system can remove heat from the refrigerated space is

$$\dot{Q}_{\text{L}} = \text{COP}_{\text{R}} \dot{Q}_{\text{gen}} = (0.55)(10^5 \text{ Btu/h}) = \mathbf{0.55 \times 10^5 \text{ Btu/h}}$$

**11-84** A reversible absorption refrigerator consists of a reversible heat engine and a reversible refrigerator. The rate at which the steam condenses, the power input to the reversible refrigerator, and the second law efficiency of an actual chiller are to be determined.

**Properties** The enthalpy of vaporization of water at 200°C is  $h_{fg} = 1939.8$  kJ/kg (Table A-4).

**Analysis** (a) The thermal efficiency of the reversible heat engine is

$$\eta_{\text{th,rev}} = 1 - \frac{T_0}{T_s} = 1 - \frac{(25 + 273.15) \text{ K}}{(200 + 273.15) \text{ K}} = 0.370$$

The COP of the reversible refrigerator is

$$\text{COP}_{\text{R,rev}} = \frac{T_L}{T_0 - T_L} = \frac{(-10 + 273.15) \text{ K}}{(25 + 273.15) - (-10 + 273.15) \text{ K}} = 7.52$$

The COP of the reversible absorption refrigerator is

$$\text{COP}_{\text{abs,rev}} = \eta_{\text{th,rev}} \text{COP}_{\text{R,rev}} = (0.370)(7.52) = 2.78$$

The heat input to the reversible heat engine is

$$\dot{Q}_{\text{in}} = \frac{\dot{Q}_L}{\text{COP}_{\text{abs,rev}}} = \frac{22 \text{ kW}}{2.78} = 7.911 \text{ kW}$$

Then, the rate at which the steam condenses becomes

$$\dot{m}_s = \frac{\dot{Q}_{\text{in}}}{h_{fg}} = \frac{7.911 \text{ kJ/s}}{1939.8 \text{ kJ/kg}} = \mathbf{0.00408 \text{ kg/s}}$$

(b) The power input to the refrigerator is equal to the power output from the heat engine

$$\dot{W}_{\text{in,R}} = \dot{W}_{\text{out,HE}} = \eta_{\text{th,rev}} \dot{Q}_{\text{in}} = (0.370)(7.911 \text{ kW}) = \mathbf{2.93 \text{ kW}}$$

(c) The second-law efficiency of an actual absorption chiller with a COP of 0.7 is

$$\eta_{\text{II}} = \frac{\text{COP}_{\text{actual}}}{\text{COP}_{\text{abs,rev}}} = \frac{0.7}{2.78} = \mathbf{0.252}$$

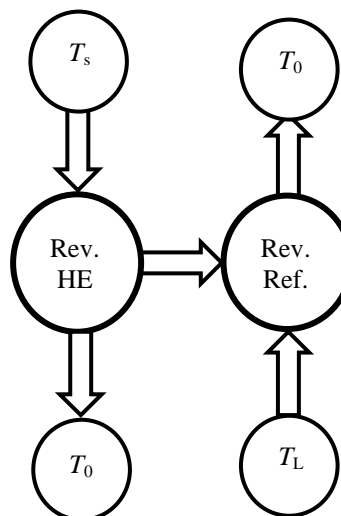

**Special Topic: Thermoelectric Power Generation and Refrigeration Systems**

**11-85C** The circuit that incorporates both thermal and electrical effects is called a thermoelectric circuit.

**11-86C** When two wires made from different metals joined at both ends (junctions) forming a closed circuit and one of the joints is heated, a current flows continuously in the circuit. This is called the Seebeck effect. When a small current is passed through the junction of two dissimilar wires, the junction is cooled. This is called the Peltier effect.

**11-87C** No.

**11-88C** No.

**11-89C** Yes.

**11-90C** When a thermoelectric circuit is broken, the current will cease to flow, and we can measure the voltage generated in the circuit by a voltmeter. The voltage generated is a function of the temperature difference, and the temperature can be measured by simply measuring voltages.

**11-91C** The performance of thermoelectric refrigerators improves considerably when semiconductors are used instead of metals.

**11-92C** The efficiency of a thermoelectric generator is limited by the Carnot efficiency because a thermoelectric generator fits into the definition of a heat engine with electrons serving as the working fluid.

**11-93E** A thermoelectric generator that operates at specified conditions is considered. The maximum thermal efficiency this thermoelectric generator can have is to be determined.

**Analysis** The maximum thermal efficiency of this thermoelectric generator is the Carnot efficiency,

$$\eta_{\text{th,max}} = \eta_{\text{th,Carnot}} = 1 - \frac{T_L}{T_H} = 1 - \frac{550\text{R}}{800\text{R}} = \mathbf{31.3\%}$$

**11-94** A thermoelectric refrigerator that operates at specified conditions is considered. The maximum COP this thermoelectric refrigerator can have and the minimum required power input are to be determined.

**Analysis** The maximum COP of this thermoelectric refrigerator is the COP of a Carnot refrigerator operating between the same temperature limits,

$$\text{COP}_{\text{max}} = \text{COP}_{\text{R,Carnot}} = \frac{1}{(T_H/T_L) - 1} = \frac{1}{(293\text{ K})/(268\text{ K}) - 1} = \mathbf{10.72}$$

Thus,

$$\dot{W}_{\text{in,min}} = \frac{\dot{Q}_L}{\text{COP}_{\text{max}}} = \frac{130\text{ W}}{10.72} = \mathbf{12.1\text{ W}}$$

**11-95** A thermoelectric cooler that operates at specified conditions with a given COP is considered. The required power input to the thermoelectric cooler is to be determined.

**Analysis** The required power input is determined from the definition of  $\text{COP}_{\text{R}}$ ,

$$\text{COP}_{\text{R}} = \frac{\dot{Q}_L}{\dot{W}_{\text{in}}} \longrightarrow \dot{W}_{\text{in}} = \frac{\dot{Q}_L}{\text{COP}_{\text{R}}} = \frac{180\text{ W}}{0.15} = \mathbf{1200\text{ W}}$$

**11-96E** A thermoelectric cooler that operates at specified conditions with a given COP is considered. The required power input to the thermoelectric cooler is to be determined.

**Analysis** The required power input is determined from the definition of  $\text{COP}_{\text{R}}$ ,

$$\text{COP}_{\text{R}} = \frac{\dot{Q}_L}{\dot{W}_{\text{in}}} \longrightarrow \dot{W}_{\text{in}} = \frac{\dot{Q}_L}{\text{COP}_{\text{R}}} = \frac{20\text{ Btu/min}}{0.15} = 133.3\text{ Btu/min} = \mathbf{3.14\text{ hp}}$$

**11-97** A thermoelectric refrigerator powered by a car battery cools 9 canned drinks in 12 h. The average COP of this refrigerator is to be determined.

**Assumptions** Heat transfer through the walls of the refrigerator is negligible.

**Properties** The properties of canned drinks are the same as those of water at room temperature,  $\rho = 1 \text{ kg/L}$  and  $c_p = 4.18 \text{ kJ/kg}\cdot^\circ\text{C}$  (Table A-3).

**Analysis** The cooling rate of the refrigerator is simply the rate of decrease of the energy of the canned drinks,

$$m = \rho V = 9 \times (1 \text{ kg/L})(0.350 \text{ L}) = 3.15 \text{ kg}$$

$$Q_{\text{cooling}} = mc\Delta T = (3.15 \text{ kg})(4.18 \text{ kJ/kg}\cdot^\circ\text{C})(25 - 3)^\circ\text{C} = 290 \text{ kJ}$$

$$\dot{Q}_{\text{cooling}} = \frac{Q_{\text{cooling}}}{\Delta t} = \frac{290 \text{ kJ}}{12 \times 3600 \text{ s}} = 0.00671 \text{ kW} = 6.71 \text{ W}$$

The electric power consumed by the refrigerator is

$$\dot{W}_{\text{in}} = \mathbf{VI} = (12 \text{ V})(3 \text{ A}) = 36 \text{ W}$$

Then the COP of the refrigerator becomes

$$\text{COP} = \frac{\dot{Q}_{\text{cooling}}}{\dot{W}_{\text{in}}} = \frac{6.71 \text{ W}}{36 \text{ W}} = \mathbf{0.186} \approx 0.20$$

**11-98E** A thermoelectric cooler is said to cool a 12-oz drink or to heat a cup of coffee in about 15 min. The average rate of heat removal from the drink, the average rate of heat supply to the coffee, and the electric power drawn from the battery of the car are to be determined.

**Assumptions** Heat transfer through the walls of the refrigerator is negligible.

**Properties** The properties of canned drinks are the same as those of water at room temperature,  $c_p = 1.0$  Btu/lbm·°F (Table A-3E).

**Analysis** (a) The average cooling rate of the refrigerator is simply the rate of decrease of the energy content of the canned drinks,

$$Q_{\text{cooling}} = mc_p \Delta T = (0.771 \text{ lbm})(1.0 \text{ Btu/lbm} \cdot ^\circ\text{F})(78 - 38)^\circ\text{F} = 30.84 \text{ Btu}$$

$$\dot{Q}_{\text{cooling}} = \frac{Q_{\text{cooling}}}{\Delta t} = \frac{30.84 \text{ Btu}}{15 \times 60 \text{ s}} \left( \frac{1055 \text{ J}}{1 \text{ Btu}} \right) = \mathbf{36.2 \text{ W}}$$

(b) The average heating rate of the refrigerator is simply the rate of increase of the energy content of the canned drinks,

$$Q_{\text{heating}} = mc_p \Delta T = (0.771 \text{ lbm})(1.0 \text{ Btu/lbm} \cdot ^\circ\text{F})(130 - 75)^\circ\text{F} = 42.4 \text{ Btu}$$

$$\dot{Q}_{\text{heating}} = \frac{Q_{\text{heating}}}{\Delta t} = \frac{42.4 \text{ Btu}}{15 \times 60 \text{ s}} \left( \frac{1055 \text{ J}}{1 \text{ Btu}} \right) = \mathbf{49.7 \text{ W}}$$

(c) The electric power drawn from the car battery during cooling and heating is

$$\dot{W}_{\text{in,cooling}} = \frac{\dot{Q}_{\text{cooling}}}{\text{COP}_{\text{cooling}}} = \frac{36.2 \text{ W}}{0.2} = \mathbf{181 \text{ W}}$$

$$\text{COP}_{\text{heating}} = \text{COP}_{\text{cooling}} + 1 = 0.2 + 1 = 1.2$$

$$\dot{W}_{\text{in,heating}} = \frac{\dot{Q}_{\text{heating}}}{\text{COP}_{\text{heating}}} = \frac{49.7 \text{ W}}{1.2} = \mathbf{41.4 \text{ W}}$$

**11-99** The maximum power a thermoelectric generator can produce is to be determined.

**Analysis** The maximum thermal efficiency this thermoelectric generator can have is

$$\eta_{\text{th,max}} = 1 - \frac{T_L}{T_H} = 1 - \frac{303 \text{ K}}{353 \text{ K}} = 0.142$$

Thus,

$$\dot{W}_{\text{out,max}} = \eta_{\text{th,max}} \dot{Q}_{\text{in}} = (0.142)(10^6 \text{ kJ/h}) = 142,000 \text{ kJ/h} = \mathbf{39.4 \text{ kW}}$$



## Review Problems

**11-100** A steady-flow Carnot refrigeration cycle with refrigerant-134a as the working fluid is considered. The COP, the condenser and evaporator pressures, and the net work input are to be determined.

**Assumptions** 1 Steady operating conditions exist. 2 Kinetic and potential energy changes are negligible.

**Analysis** (a) The COP of this refrigeration cycle is determined from

$$\text{COP}_{R,C} = \frac{1}{(T_H / T_L) - 1} = \frac{1}{(303 \text{ K}) / (253 \text{ K}) - 1} = \mathbf{5.06}$$

(b) The condenser and evaporative pressures are (Table A-11)

$$P_{\text{evap}} = P_{\text{sat}@-20^\circ\text{C}} = \mathbf{132.82 \text{ kPa}}$$

$$P_{\text{cond}} = P_{\text{sat}@30^\circ\text{C}} = \mathbf{770.64 \text{ kPa}}$$

(c) The net work input is determined from

$$h_1 = (h_f + x_1 h_{fg})_{@-20^\circ\text{C}} = 25.49 + (0.15)(212.91) = 57.43 \text{ kJ/kg}$$

$$h_2 = (h_f + x_2 h_{fg})_{@-20^\circ\text{C}} = 25.49 + (0.80)(212.91) = 195.82 \text{ kJ/kg}$$

$$q_L = h_2 - h_1 = 195.82 - 57.43 = 138.4 \text{ kJ/kg}$$

$$w_{\text{net,in}} = \frac{q_L}{\text{COP}_R} = \frac{138.4 \text{ kJ/kg}}{5.06} = \mathbf{27.35 \text{ kJ/kg}}$$

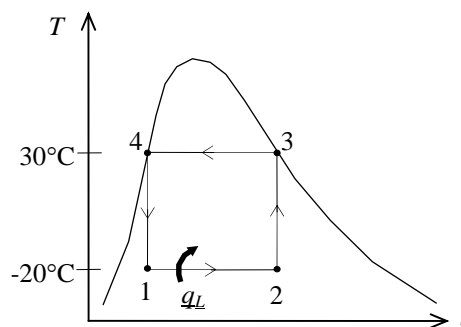

**11-101** A heat pump that operates on the ideal vapor-compression cycle with refrigerant-134a as the working fluid is used to heat a house. The rate of heat supply to the house, the volume flow rate of the refrigerant at the compressor inlet, and the COP of this heat pump are to be determined.

**Assumptions** 1 Steady operating conditions exist. 2 Kinetic and potential energy changes are negligible.

**Analysis** (a) In an ideal vapor-compression refrigeration cycle, the compression process is isentropic, the refrigerant enters the compressor as a saturated vapor at the evaporator pressure, and leaves the condenser as saturated liquid at the condenser pressure. From the refrigerant tables (Tables A-12 and A-13),

$$P_1 = 200 \text{ kPa} \left. \begin{array}{l} h_1 = h_g @ 200 \text{ kPa} = 244.46 \text{ kJ/kg} \\ s_1 = s_g @ 200 \text{ kPa} = 0.93773 \text{ kJ/kg} \cdot \text{K} \\ \text{sat. vapor} \end{array} \right\} \nu_1 = \nu_g @ 200 \text{ kPa} = 0.099867 \text{ m}^3/\text{kg}$$

$$P_2 = 0.9 \text{ MPa} \left. \begin{array}{l} h_2 = 275.75 \text{ kJ/kg} \\ s_2 = s_1 \end{array} \right\}$$

$$P_3 = 0.9 \text{ MPa} \left. \begin{array}{l} h_3 = h_f @ 0.9 \text{ MPa} = 101.61 \text{ kJ/kg} \\ \text{sat. liquid} \end{array} \right\}$$

$$h_4 \cong h_3 = 101.61 \text{ kJ/kg} \text{ (throttling)}$$

The rate of heat supply to the house is determined from

$$\dot{Q}_H = \dot{m}(h_2 - h_3) = (0.32 \text{ kg/s})(275.75 - 101.61) \text{ kJ/kg} = \mathbf{55.73 \text{ kW}}$$

(b) The volume flow rate of the refrigerant at the compressor inlet is

$$\dot{V}_1 = \dot{m}\nu_1 = (0.32 \text{ kg/s})(0.099867 \text{ m}^3/\text{kg}) = \mathbf{0.0320 \text{ m}^3/\text{s}}$$

(c) The COP of this heat pump is determined from

$$\text{COP}_R = \frac{q_L}{w_{\text{in}}} = \frac{h_2 - h_3}{h_2 - h_1} = \frac{275.75 - 101.61}{275.75 - 244.46} = \mathbf{5.57}$$

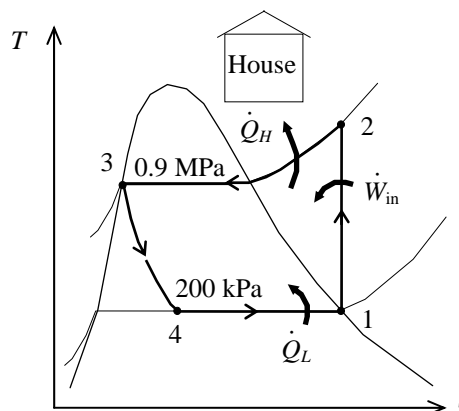

**11-102** A relation for the COP of the two-stage refrigeration system with a flash chamber shown in Fig. 11-12 is to be derived.

**Analysis** The coefficient of performance is determined from

$$\text{COP}_R = \frac{q_L}{w_{\text{in}}}$$

where

$$q_L = (1 - x_6)(h_1 - h_8) \quad \text{with} \quad x_6 = \frac{h_6 - h_f}{h_{fg}}$$

$$w_{\text{in}} = w_{\text{compl, I}} + w_{\text{compl, II}} = (1 - x_6)(h_2 - h_1) + (1)(h_4 - h_9)$$

**11-103** A two-stage compression refrigeration system using refrigerant-134a as the working fluid is considered. The fraction of the refrigerant that evaporates as it is throttled to the flash chamber, the amount of heat removed from the refrigerated space, the compressor work, and the COP are to be determined.

**Assumptions** 1 Steady operating conditions exist. 2 Kinetic and potential energy changes are negligible. 3 The flashing chamber is adiabatic.

**Analysis** (a) The enthalpies of the refrigerant at several states are determined from the refrigerant tables to be (Tables A-11, A-12, and A-13)

$$h_1 = 239.16 \text{ kJ/kg}, \quad h_2 = 260.58 \text{ kJ/kg}$$

$$h_3 = 255.55 \text{ kJ/kg},$$

$$h_5 = 95.47 \text{ kJ/kg}, \quad h_6 = 95.47 \text{ kJ/kg}$$

$$h_7 = 63.94 \text{ kJ/kg}, \quad h_8 = 63.94 \text{ kJ/kg}$$

The fraction of the refrigerant that evaporates as it is throttled to the flash chamber is simply the quality at state 6,

$$x_6 = \frac{h_6 - h_f}{h_{fg}} = \frac{95.47 - 63.94}{191.62} = \mathbf{0.1646}$$

(b) The enthalpy at state 9 is determined from an energy balance on the mixing chamber:

$$\dot{E}_{in} - \dot{E}_{out} = \Delta \dot{E}_{system} \stackrel{\phi^0(\text{steady})}{=} 0 \rightarrow \dot{E}_{in} = \dot{E}_{out}$$

$$\sum \dot{m}_e h_e = \sum \dot{m}_i h_i$$

$$(1)h_9 = x_6 h_3 + (1 - x_6)h_2$$

$$h_9 = (0.1646)(255.55) + (1 - 0.1646)(260.58) = 259.75 \text{ kJ/kg}$$

$$\left. \begin{array}{l} P_9 = 0.4 \text{ MPa} \\ h_9 = 259.75 \text{ kJ/kg} \end{array} \right\} s_9 = 0.94168 \text{ kJ/kg} \cdot \text{K}$$

Also,

$$\left. \begin{array}{l} P_4 = 0.8 \text{ MPa} \\ s_4 = s_9 = 0.94168 \text{ kJ/kg} \cdot \text{K} \end{array} \right\} h_4 = 274.47 \text{ kJ/kg}$$

Then the amount of heat removed from the refrigerated space and the compressor work input per unit mass of refrigerant flowing through the condenser are

$$q_L = (1 - x_6)(h_1 - h_8) = (1 - 0.1646)(239.16 - 63.94) \text{ kJ/kg} = \mathbf{146.4 \text{ kJ/kg}}$$

$$\begin{aligned} w_{in} &= w_{\text{compI, in}} + w_{\text{compII, in}} = (1 - x_6)(h_2 - h_1) + (1)(h_4 - h_9) \\ &= (1 - 0.1646)(260.58 - 239.16) \text{ kJ/kg} + (274.47 - 259.75) \text{ kJ/kg} = \mathbf{32.6 \text{ kJ/kg}} \end{aligned}$$

(c) The coefficient of performance is determined from

$$\text{COP}_R = \frac{q_L}{w_{in}} = \frac{146.4 \text{ kJ/kg}}{32.6 \text{ kJ/kg}} = \mathbf{4.49}$$

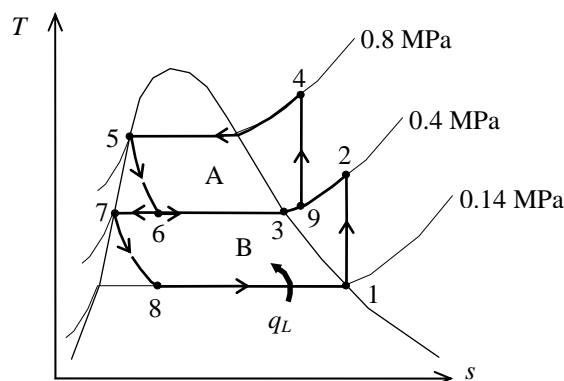

**11-104** A refrigerator operating on a vapor-compression refrigeration cycle with refrigerant-134a as the working fluid is considered. The process with the greatest exergy loss is to be determined.

**Assumptions 1** Steady operating conditions exist. **2** Kinetic and potential energy changes are negligible.

**Analysis** In this cycle, the refrigerant enters the compressor as a saturated vapor at the evaporator pressure, and leaves the condenser as saturated liquid at the condenser pressure. The compression process is not isentropic. From the refrigerant tables (Tables A-11, A-12, and A-13),

$$\begin{aligned} T_1 = -10^\circ\text{C} \left. \begin{array}{l} h_1 = h_g @ -10^\circ\text{C} = 244.51 \text{ kJ/kg} \\ \text{sat. vapor} \end{array} \right\} s_1 = s_g @ -10^\circ\text{C} = 0.93766 \text{ kJ/kg} \cdot \text{K} \\ \\ P_2 = 700 \text{ kPa} \left. \begin{array}{l} h_{2s} = 270.38 \text{ kJ/kg} \\ s_2 = s_1 \end{array} \right\} \\ \\ P_3 = 700 \text{ kPa} \left. \begin{array}{l} h_3 = h_f @ 700 \text{ kPa} = 88.82 \text{ kJ/kg} \\ \text{sat. liquid} \end{array} \right\} s_3 = s_f @ 700 \text{ kPa} = 0.33230 \text{ kJ/kg} \cdot \text{K} \\ \\ h_4 \cong h_3 = 88.82 \text{ kJ/kg} \quad (\text{throttling}) \\ \\ T_4 = -10^\circ\text{C} \left. \begin{array}{l} h_4 = 88.82 \text{ kJ/kg} \\ \end{array} \right\} s_4 = 0.34605 \text{ kJ/kg} \cdot \text{K} \end{aligned}$$

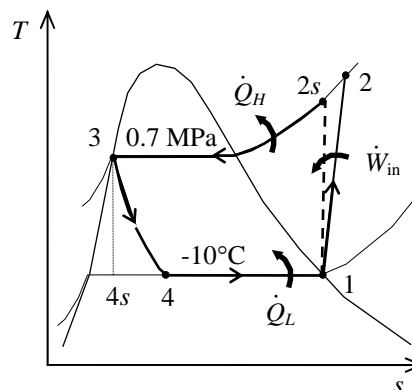

The actual enthalpy at the compressor exit is determined by using the compressor efficiency:

$$\eta_C = \frac{h_{2s} - h_1}{h_2 - h_1} \longrightarrow h_2 = h_1 + \frac{h_{2s} - h_1}{\eta_C} = 244.51 + \frac{270.38 - 244.51}{0.85} = 274.95 \text{ kJ/kg}$$

and

$$\left. \begin{array}{l} P_2 = 700 \text{ kPa} \\ h_2 = 274.95 \text{ kJ/kg} \end{array} \right\} s_2 = 0.95252 \text{ kJ/kg}$$

The heat added in the evaporator and that rejected in the condenser are

$$\begin{aligned} q_L &= h_1 - h_4 = (244.51 - 88.82) \text{ kJ/kg} = 155.69 \text{ kJ/kg} \\ q_H &= h_2 - h_3 = (274.95 - 88.82) \text{ kJ/kg} = 186.13 \text{ kJ/kg} \end{aligned}$$

The exergy destruction during a process of a stream from an inlet state to exit state is given by

$$x_{\text{dest}} = T_0 s_{\text{gen}} = T_0 \left( s_e - s_i - \frac{q_{\text{in}}}{T_{\text{source}}} + \frac{q_{\text{out}}}{T_{\text{sink}}} \right)$$

Application of this equation for each process of the cycle gives

$$\begin{aligned} x_{\text{destroyed},12} &= T_0 (s_2 - s_1) = (295 \text{ K})(0.95252 - 0.93766) \text{ kJ/kg} \cdot \text{K} = 4.38 \text{ kJ/kg} \\ x_{\text{destroyed},23} &= T_0 \left( s_3 - s_2 + \frac{q_H}{T_H} \right) = (295 \text{ K}) \left( 0.33230 - 0.95252 + \frac{186.13 \text{ kJ/kg}}{295 \text{ K}} \right) = 3.17 \text{ kJ/kg} \\ x_{\text{destroyed},34} &= T_0 (s_4 - s_3) = (295 \text{ K})(0.34605 - 0.33230) \text{ kJ/kg} \cdot \text{K} = 4.06 \text{ kJ/kg} \\ x_{\text{destroyed},41} &= T_0 \left( s_1 - s_4 - \frac{q_L}{T_L} \right) = (295 \text{ K}) \left( 0.93766 - 0.34605 - \frac{155.69 \text{ kJ/kg}}{273 \text{ K}} \right) = \mathbf{6.29 \text{ kJ/kg}} \end{aligned}$$

The greatest exergy destruction occurs in the evaporator. Note that heat is absorbed from freezing water at  $0^\circ\text{C}$  (273 K) and rejected to the ambient air at  $22^\circ\text{C}$  (295 K), which is also taken as the dead state temperature. Alternatively, one may use the standard  $25^\circ\text{C}$  (298 K) as the dead state temperature, and perform the calculations accordingly.

**11-105** A refrigerator operating on a vapor-compression refrigeration cycle with refrigerant-134a as the working fluid is considered. The process with the greatest exergy loss is to be determined.

**Assumptions 1** Steady operating conditions exist. **2** Kinetic and potential energy changes are negligible.

**Analysis** From the refrigerant tables (Tables A-11, A-12, and A-13),

$$\left. \begin{array}{l} T_1 = -10^\circ\text{C} \\ \text{sat. vapor} \end{array} \right\} \begin{array}{l} h_1 = h_g @ -10^\circ\text{C} = 244.51 \text{ kJ/kg} \\ s_1 = s_g @ -10^\circ\text{C} = 0.93766 \text{ kJ/kg}\cdot\text{K} \end{array}$$

$$\left. \begin{array}{l} P_2 = 700 \text{ kPa} \\ s_2 = s_1 \end{array} \right\} h_{2s} = 270.38 \text{ kJ/kg}$$

$$\left. \begin{array}{l} P_3 = 700 \text{ kPa} \\ T_3 = T_{\text{sat}} @ 700 \text{ kPa} - 2.7 \\ \quad = 26.7 - 2.7 = 24^\circ\text{C} \end{array} \right\} \begin{array}{l} h_3 \cong h_f @ 24^\circ\text{C} = 84.98 \text{ kJ/kg} \\ s_3 \cong s_f @ 24^\circ\text{C} = 0.31958 \text{ kJ/kg}\cdot\text{K} \end{array}$$

$$h_4 \cong h_3 = 84.98 \text{ kJ/kg} \quad (\text{throttling})$$

$$\left. \begin{array}{l} T_4 = -10^\circ\text{C} \\ h_4 = 84.98 \text{ kJ/kg} \end{array} \right\} s_4 = 0.33146 \text{ kJ/kg}\cdot\text{K}$$

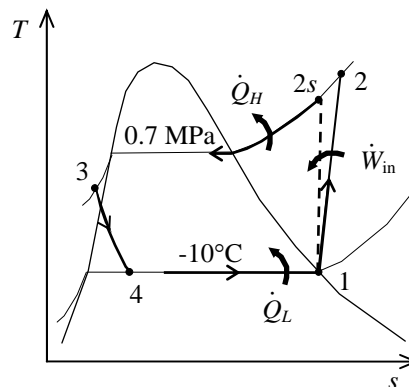

The actual enthalpy at the compressor exit is determined by using the compressor efficiency:

$$\eta_C = \frac{h_{2s} - h_1}{h_2 - h_1} \longrightarrow h_2 = h_1 + \frac{h_{2s} - h_1}{\eta_C} = 244.51 + \frac{270.38 - 244.51}{0.85} = 274.95 \text{ kJ/kg}$$

$$\text{and } \left. \begin{array}{l} P_2 = 700 \text{ kPa} \\ h_2 = 274.95 \text{ kJ/kg} \end{array} \right\} s_2 = 0.95252 \text{ kJ/kg}$$

The heat added in the evaporator and that rejected in the condenser are

$$q_L = h_1 - h_4 = (244.51 - 84.98) \text{ kJ/kg} = 159.53 \text{ kJ/kg}$$

$$q_H = h_2 - h_3 = (274.95 - 84.98) \text{ kJ/kg} = 189.97 \text{ kJ/kg}$$

The exergy destruction during a process of a stream from an inlet state to exit state is given by

$$x_{\text{dest}} = T_0 s_{\text{gen}} = T_0 \left( s_e - s_i - \frac{q_{\text{in}}}{T_{\text{source}}} + \frac{q_{\text{out}}}{T_{\text{sink}}} \right)$$

Application of this equation for each process of the cycle gives

$$x_{\text{destroyed},12} = T_0 (s_2 - s_1) = (295 \text{ K})(0.95252 - 0.93766) \text{ kJ/kg}\cdot\text{K} = 4.38 \text{ kJ/kg}$$

$$x_{\text{destroyed},23} = T_0 \left( s_3 - s_2 + \frac{q_H}{T_H} \right) = (295 \text{ K}) \left( 0.31958 - 0.95252 + \frac{189.97 \text{ kJ/kg}}{295 \text{ K}} \right) = 3.25 \text{ kJ/kg}$$

$$x_{\text{destroyed},34} = T_0 (s_4 - s_3) = (295 \text{ K})(0.33146 - 0.31958) \text{ kJ/kg}\cdot\text{K} = 3.50 \text{ kJ/kg}$$

$$x_{\text{destroyed},41} = T_0 \left( s_1 - s_4 - \frac{q_L}{T_L} \right) = (295 \text{ K}) \left( 0.93766 - 0.33146 - \frac{159.53 \text{ kJ/kg}}{273 \text{ K}} \right) = \mathbf{6.44 \text{ kJ/kg}}$$

The greatest exergy destruction occurs in the evaporator. Note that heat is absorbed from freezing water at  $0^\circ\text{C}$  (273 K) and rejected to the ambient air at  $22^\circ\text{C}$  (295 K), which is also taken as the dead state temperature. Alternatively, one may use the standard  $25^\circ\text{C}$  (298 K) as the dead state temperature, and perform the calculations accordingly.

**11-106** A refrigerator operating on a vapor-compression refrigeration cycle with refrigerant-134a as the working fluid is considered. The process with the greatest exergy loss is to be determined.

**Assumptions 1** Steady operating conditions exist. **2** Kinetic and potential energy changes are negligible.

**Analysis** In this cycle, the refrigerant leaves the condenser as saturated liquid at the condenser pressure. The compression process is not isentropic. From the refrigerant tables (Tables A-11, A-12, and A-13),

$$\left. \begin{array}{l} P_1 = P_{\text{sat @ } -37^\circ\text{C}} = 60 \text{ kPa} \\ T_1 = -37 + 7 = -30^\circ\text{C} \end{array} \right\} \begin{array}{l} h_1 = 233.09 \text{ kJ/kg} \\ s_1 = 0.9865 \text{ kJ/kg} \cdot \text{K} \end{array}$$

$$\left. \begin{array}{l} P_2 = 1.2 \text{ MPa} \\ s_2 = s_1 \end{array} \right\} h_{2s} = 298.11 \text{ kJ/kg}$$

$$\left. \begin{array}{l} P_3 = 1.2 \text{ MPa} \\ \text{sat. liquid} \end{array} \right\} \begin{array}{l} h_3 = h_f @ 1.2 \text{ MPa} = 117.77 \text{ kJ/kg} \\ s_3 = s_f @ 1.2 \text{ MPa} = 0.42441 \text{ kJ/kg} \cdot \text{K} \end{array}$$

$$h_4 \cong h_3 = 117.77 \text{ kJ/kg} \quad (\text{throttling})$$

$$\left. \begin{array}{l} T_4 = -37^\circ\text{C} \\ h_4 = 117.77 \text{ kJ/kg} \end{array} \right\} \begin{array}{l} x_4 = 0.5089 \\ s_4 = 0.4988 \text{ kJ/kg} \cdot \text{K} \end{array}$$

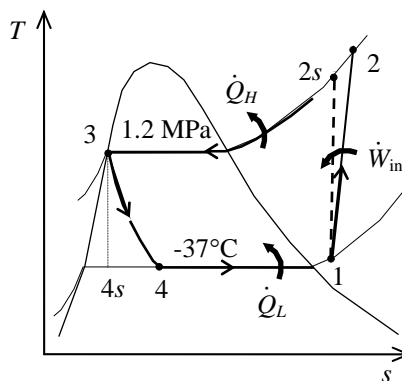

The actual enthalpy at the compressor exit is determined by using the compressor efficiency:

$$\eta_C = \frac{h_{2s} - h_1}{h_2 - h_1} \longrightarrow h_2 = h_1 + \frac{h_{2s} - h_1}{\eta_C} = 233.09 + \frac{298.11 - 233.09}{0.90} = 305.33 \text{ kJ/kg}$$

$$\text{and } \left. \begin{array}{l} P_2 = 1.2 \text{ MPa} \\ h_2 = 305.33 \text{ Btu/lbm} \end{array} \right\} s_2 = 1.0075 \text{ kJ/kg} \cdot \text{K}$$

The heat added in the evaporator and that rejected in the condenser are

$$\begin{aligned} q_L &= h_1 - h_4 = (233.09 - 117.77) \text{ kJ/kg} = 115.32 \text{ kJ/kg} \\ q_H &= h_2 - h_3 = (305.33 - 117.77) \text{ kJ/kg} = 187.56 \text{ kJ/kg} \end{aligned}$$

The exergy destruction during a process of a stream from an inlet state to exit state is given by

$$x_{\text{dest}} = T_0 s_{\text{gen}} = T_0 \left( s_e - s_i - \frac{q_{\text{in}}}{T_{\text{source}}} + \frac{q_{\text{out}}}{T_{\text{sink}}} \right)$$

Application of this equation for each process of the cycle gives

$$\begin{aligned} x_{\text{destroyed},12} &= T_0 (s_2 - s_1) = (303 \text{ K})(1.0075 - 0.9865) \text{ kJ/kg} \cdot \text{K} = 6.36 \text{ kJ/kg} \\ x_{\text{destroyed},23} &= T_0 \left( s_3 - s_2 + \frac{q_H}{T_H} \right) = (303 \text{ K}) \left( 0.42441 - 1.0075 + \frac{187.56 \text{ kJ/kg}}{303 \text{ K}} \right) = 10.88 \text{ kJ/kg} \\ x_{\text{destroyed},34} &= T_0 (s_4 - s_3) = (303 \text{ K})(0.4988 - 0.42441) \text{ kJ/kg} \cdot \text{K} = \mathbf{22.54 \text{ kJ/kg}} \\ x_{\text{destroyed},41} &= T_0 \left( s_1 - s_4 - \frac{q_L}{T_L} \right) = (303 \text{ K}) \left( 0.9865 - 0.4988 - \frac{115.32 \text{ kJ/kg}}{(-34 + 273) \text{ K}} \right) = 1.57 \text{ kJ/kg} \end{aligned}$$

The greatest exergy destruction occurs in the expansion valve. Note that heat is absorbed from fruits at  $-34^\circ\text{C}$  (239 K) and rejected to the ambient air at  $30^\circ\text{C}$  (303 K), which is also taken as the dead state temperature. Alternatively, one may use the standard  $25^\circ\text{C}$  (298 K) as the dead state temperature, and perform the calculations accordingly.

**11-107** A refrigerator operating on a vapor-compression refrigeration cycle with refrigerant-134a as the working fluid is considered. The process with the greatest exergy loss is to be determined.

**Assumptions 1** Steady operating conditions exist. **2** Kinetic and potential energy changes are negligible.

**Analysis** From the refrigerant tables (Tables A-11, A-12, and A-13),

$$\left. \begin{array}{l} P_1 = P_{\text{sat}} @ -37^\circ\text{C} = 60 \text{ kPa} \\ T_1 = -37 + 7 = -30^\circ\text{C} \end{array} \right\} \begin{array}{l} h_1 = 233.09 \text{ kJ/kg} \\ s_1 = 0.9865 \text{ kJ/kg} \cdot \text{K} \end{array}$$

$$\left. \begin{array}{l} P_2 = 1.2 \text{ MPa} \\ s_2 = s_1 \end{array} \right\} h_{2s} = 298.11 \text{ kJ/kg}$$

$$\left. \begin{array}{l} P_3 = 1.2 \text{ MPa} \\ T_3 = T_{\text{sat}} @ 1.2 \text{ MPa} - 6.3 \\ \quad = 46.3 - 6.3 = 40^\circ\text{C} \end{array} \right\} \begin{array}{l} h_3 \cong h_f @ 40^\circ\text{C} = 108.26 \text{ kJ/kg} \\ s_3 \cong s_f @ 40^\circ\text{C} = 0.39486 \text{ kJ/kg} \cdot \text{K} \end{array}$$

$$h_4 \cong h_3 = 108.26 \text{ kJ/kg} \quad (\text{throttling})$$

$$\left. \begin{array}{l} T_4 = -37^\circ\text{C} \\ h_4 = 108.26 \text{ kJ/kg} \end{array} \right\} \begin{array}{l} x_4 = 0.4665 \\ s_4 = 0.4585 \text{ kJ/kg} \cdot \text{K} \end{array}$$

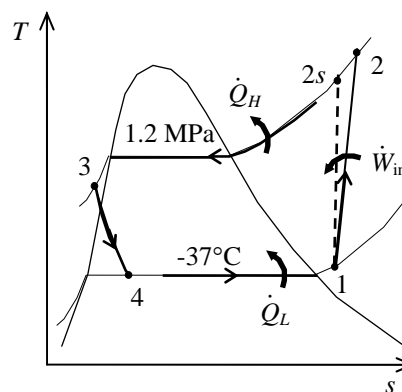

The actual enthalpy at the compressor exit is determined by using the compressor efficiency:

$$\eta_C = \frac{h_{2s} - h_1}{h_2 - h_1} \rightarrow h_2 = h_1 + \frac{h_{2s} - h_1}{\eta_C} = 233.09 + \frac{298.11 - 233.09}{0.90} = 305.33 \text{ kJ/kg}$$

$$\text{and } \left. \begin{array}{l} P_2 = 1.2 \text{ MPa} \\ h_2 = 305.33 \text{ Btu/lbm} \end{array} \right\} s_2 = 1.0075 \text{ kJ/kg} \cdot \text{K}$$

The heat added in the evaporator and that rejected in the condenser are

$$q_L = h_1 - h_4 = (233.09 - 108.26) \text{ kJ/kg} = 124.83 \text{ kJ/kg}$$

$$q_H = h_2 - h_3 = (305.33 - 108.26) \text{ kJ/kg} = 197.07 \text{ kJ/kg}$$

The exergy destruction during a process of a stream from an inlet state to exit state is given by

$$x_{\text{dest}} = T_0 s_{\text{gen}} = T_0 \left( s_e - s_i - \frac{q_{\text{in}}}{T_{\text{source}}} + \frac{q_{\text{out}}}{T_{\text{sink}}} \right)$$

Application of this equation for each process of the cycle gives

$$x_{\text{destroyed},12} = T_0 (s_2 - s_1) = (303 \text{ K})(1.0075 - 0.9865) \text{ kJ/kg} \cdot \text{K} = 6.36 \text{ kJ/kg}$$

$$x_{\text{destroyed},23} = T_0 \left( s_3 - s_2 + \frac{q_H}{T_H} \right) = (303 \text{ K}) \left( 0.39486 - 1.0075 + \frac{197.07 \text{ kJ/kg}}{303 \text{ K}} \right) = 11.44 \text{ kJ/kg}$$

$$x_{\text{destroyed},34} = T_0 (s_4 - s_3) = (303 \text{ K})(0.4585 - 0.39486) \text{ kJ/kg} \cdot \text{K} = \mathbf{19.28 \text{ kJ/kg}}$$

$$x_{\text{destroyed},41} = T_0 \left( s_1 - s_4 - \frac{q_L}{T_L} \right) = (303 \text{ K}) \left( 0.9865 - 0.4585 - \frac{124.83 \text{ kJ/kg}}{(-34 + 273) \text{ K}} \right) = 1.73 \text{ kJ/kg}$$

The greatest exergy destruction occurs in the expansion valve. Note that heat is absorbed from fruits at  $-34^\circ\text{C}$  (239 K) and rejected to the ambient air at  $30^\circ\text{C}$  (303 K), which is also taken as the dead state temperature. Alternatively, one may use the standard  $25^\circ\text{C}$  (298 K) as the dead state temperature, and perform the calculations accordingly.

**11-108E** A two-evaporator compression refrigeration cycle with refrigerant-134a as the working fluid is considered. The cooling load of both evaporators per unit of flow through the compressor and the COP of the system are to be determined.

**Assumptions** 1 Steady operating conditions exist. 2 Kinetic and potential energy changes are negligible.

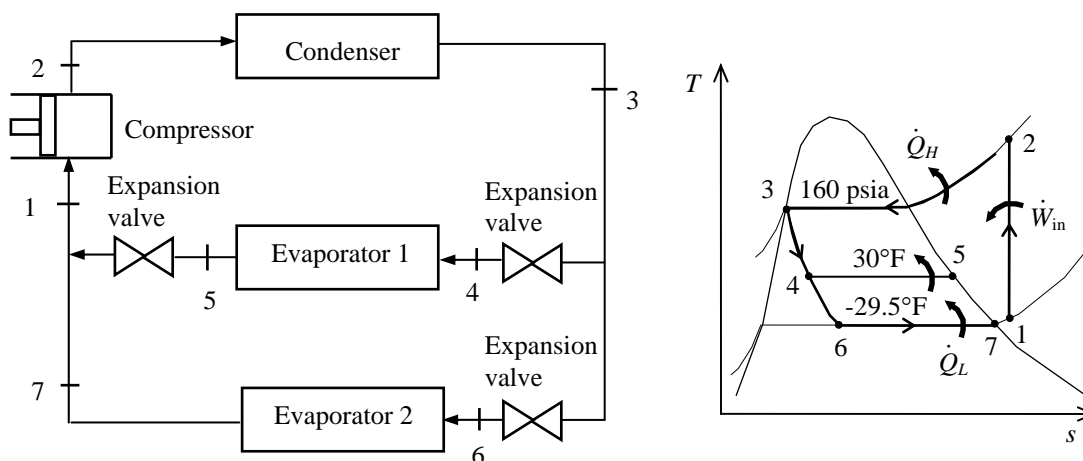

**Analysis** From the refrigerant tables (Tables A-11E, A-12E, and A-13E),

$$\left. \begin{array}{l} P_3 = 160 \text{ psia} \\ \text{sat. liquid} \end{array} \right\} h_3 = h_f @ 160 \text{ psia} = 48.519 \text{ Btu/lbm}$$

$$h_4 = h_6 \cong h_3 = 48.519 \text{ Btu/lbm} \quad (\text{throttling})$$

$$\left. \begin{array}{l} T_5 = 30^\circ\text{F} \\ \text{sat. vapor} \end{array} \right\} h_5 = h_g @ 30^\circ\text{F} = 107.40 \text{ Btu/lbm}$$

$$\left. \begin{array}{l} T_7 = -29.5^\circ\text{F} \\ \text{sat. vapor} \end{array} \right\} h_7 = h_g @ -29.5^\circ\text{F} = 98.68 \text{ Btu/lbm}$$

For a unit mass flowing through the compressor, the fraction of mass flowing through Evaporator II is denoted by  $x$  and that through Evaporator I is  $y$  ( $y = 1-x$ ). From the cooling loads specification,

$$\begin{aligned} \dot{Q}_{L, \text{evap 1}} &= 2\dot{Q}_{L, \text{evap 2}} \\ x(h_5 - h_4) &= 2y(h_7 - h_6) \end{aligned}$$

where

$$x = 1 - y$$

Combining these results and solving for  $y$  gives

$$y = \frac{h_5 - h_4}{2(h_7 - h_6) + (h_5 - h_4)} = \frac{107.40 - 48.519}{2(98.68 - 48.519) + (107.40 - 48.519)} = 0.3698$$

Then,

$$x = 1 - y = 1 - 0.3698 = 0.6302$$

Applying an energy balance to the point in the system where the two evaporator streams are recombined gives



$$xh_5 + yh_7 = h_1 \longrightarrow h_1 = \frac{xh_5 + yh_7}{1} = \frac{(0.6302)(107.40) + (0.3698)(98.68)}{1} = 104.18 \text{ Btu/lbm}$$

Then,

$$\left. \begin{array}{l} P_1 = P_{\text{sat @ } -29.5^\circ\text{F}} \cong 10 \text{ psia} \\ h_1 = 104.18 \text{ Btu/lbm} \end{array} \right\} s_1 = 0.2418 \text{ Btu/lbm} \cdot \text{R}$$

$$\left. \begin{array}{l} P_2 = 160 \text{ psia} \\ s_2 = s_1 \end{array} \right\} h_2 = 131.14 \text{ Btu/lbm}$$

The cooling load of both evaporators per unit mass through the compressor is

$$\begin{aligned} q_L &= x(h_5 - h_4) + y(h_7 - h_6) \\ &= (0.6302)(107.40 - 48.519) \text{ Btu/lbm} + (0.3698)(98.68 - 48.519) \text{ Btu/lbm} \\ &= \mathbf{55.66 \text{ Btu/lbm}} \end{aligned}$$

The work input to the compressor is

$$w_{\text{in}} = h_2 - h_1 = (131.14 - 104.18) \text{ Btu/lbm} = 26.96 \text{ Btu/lbm}$$

The COP of this refrigeration system is determined from its definition,

$$\text{COP}_R = \frac{q_L}{w_{\text{in}}} = \frac{55.66 \text{ Btu/lbm}}{26.96 \text{ Btu/lbm}} = \mathbf{2.06}$$

**11-109E** A two-evaporator compression refrigeration cycle with refrigerant-134a as the working fluid is considered. The process with the greatest exergy destruction is to be determined.

**Assumptions** 1 Steady operating conditions exist. 2 Kinetic and potential energy changes are negligible.

**Analysis** From Prob. 11-107E and the refrigerant tables (Tables A-11E, A-12E, and A-13E),

$$\begin{aligned} s_1 &= s_2 = 0.2418 \text{ Btu/lbm} \cdot \text{R} \\ s_3 &= 0.09774 \text{ Btu/lbm} \cdot \text{R} \\ s_4 &= 0.10238 \text{ Btu/lbm} \cdot \text{R} \\ s_5 &= 0.22260 \text{ Btu/lbm} \cdot \text{R} \\ s_6 &= 0.11286 \text{ Btu/lbm} \cdot \text{R} \\ s_7 &= 0.22948 \text{ Btu/lbm} \cdot \text{R} \\ x &= 0.6302 \\ y &= 1 - x = 0.3698 \\ q_{L,45} &= h_5 - h_4 = 58.881 \text{ Btu/lbm} \\ q_{L,67} &= h_7 - h_6 = 50.161 \text{ Btu/lbm} \\ q_H &= 82.621 \text{ Btu/lbm} \end{aligned}$$

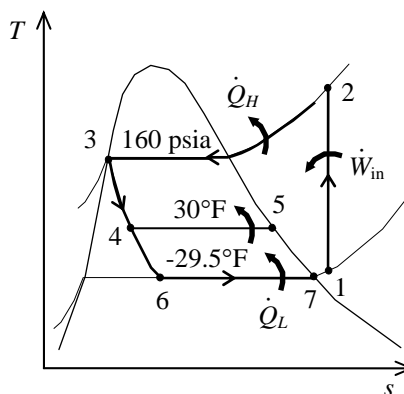

The exergy destruction during a process of a stream from an inlet state to exit state is given by

$$x_{\text{dest}} = T_0 s_{\text{gen}} = T_0 \left( s_e - s_i - \frac{q_{\text{in}}}{T_{\text{source}}} + \frac{q_{\text{out}}}{T_{\text{sink}}} \right)$$

Application of this equation for each process of the cycle gives the exergy destructions per unit mass flowing through the compressor:

$$x_{\text{destroyed},23} = T_0 \left( s_3 - s_2 + \frac{q_H}{T_H} \right) = (555 \text{ R}) \left( 0.09774 - 0.2418 + \frac{82.621 \text{ Btu/lbm}}{555 \text{ R}} \right) = 2.67 \text{ Btu/lbm}$$

$$\begin{aligned} x_{\text{destroyed},346} &= T_0 (x s_4 + y s_6 - s_3) \\ &= (555 \text{ R}) (0.6302 \times 0.10238 + 0.3698 \times 0.11286 - 0.09774) \text{ Btu/lbm} \cdot \text{R} = 4.73 \text{ Btu/lbm} \end{aligned}$$

$$\begin{aligned} x_{\text{destroyed},45} &= x T_0 \left( s_5 - s_4 - \frac{q_{L,45}}{T_L} \right) \\ &= (0.6302)(555 \text{ R}) \left( 0.22260 - 0.10238 - \frac{58.881 \text{ Btu/lbm}}{495 \text{ R}} \right) = 0.44 \text{ Btu/lbm} \end{aligned}$$

$$\begin{aligned} x_{\text{destroyed},67} &= y T_0 \left( s_7 - s_6 - \frac{q_{L,67}}{T_L} \right) \\ &= (0.3698)(555 \text{ R}) \left( 0.22948 - 0.11286 - \frac{50.161 \text{ Btu/lbm}}{440 \text{ R}} \right) = 0.54 \text{ Btu/lbm} \end{aligned}$$

$$\begin{aligned} \dot{X}_{\text{destroyed},\text{mixing}} &= T_0 (s_1 - x s_5 - y s_6) \\ &= (555 \text{ R}) [0.2418 - (0.6302)(0.22260) - (0.3698)(0.11286)] = \mathbf{3.18 \text{ Btu/lbm}} \end{aligned}$$

For isentropic processes, the exergy destruction is zero:

$$\dot{X}_{\text{destroyed},12} = 0$$

The greatest exergy destruction occurs during the mixing process. Note that heat is absorbed in evaporator 2 from a reservoir at  $-20^\circ\text{F}$  (440 R), in evaporator 1 from a reservoir at  $35^\circ\text{F}$  (495 R), and rejected to a reservoir at  $95^\circ\text{F}$  (555 R), which is also taken as the dead state temperature.

**11-110** A two-stage compression refrigeration system with a separation unit is considered. The rate of cooling and the power requirement are to be determined.

**Assumptions** 1 Steady operating conditions exist. 2 Kinetic and potential energy changes are negligible.

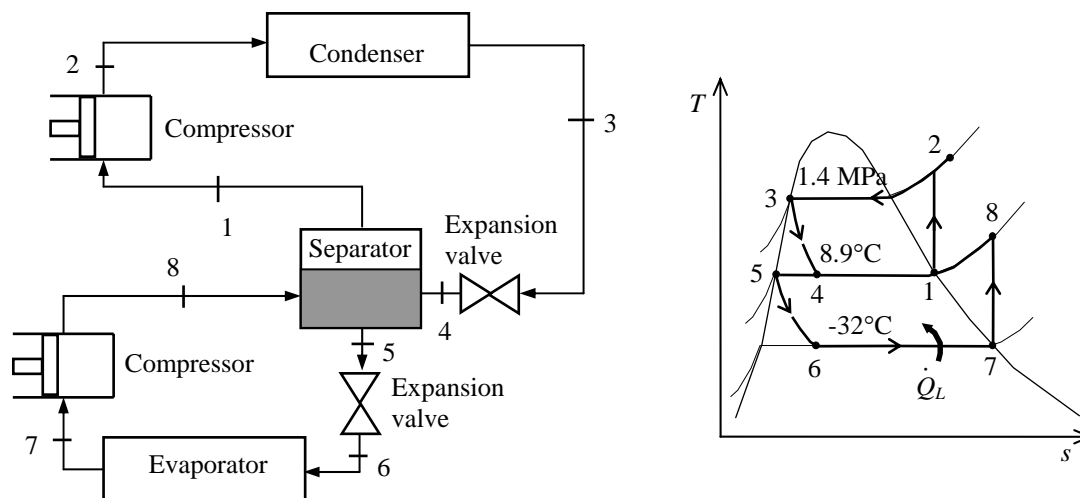

**Analysis** From the refrigerant tables (Tables A-11, A-12, and A-13),

$$\left. \begin{array}{l} T_1 = 8.9^\circ\text{C} \\ \text{sat. vapor} \end{array} \right\} \begin{array}{l} h_1 = h_g @ 8.9^\circ\text{C} = 255.55 \text{ kJ/kg} \\ s_1 = s_g @ 8.9^\circ\text{C} = 0.92691 \text{ kJ/kg}\cdot\text{K} \end{array}$$

$$\left. \begin{array}{l} P_2 = 1400 \text{ kPa} \\ s_2 = s_1 \end{array} \right\} h_2 = 281.49 \text{ kJ/kg}$$

$$\left. \begin{array}{l} P_3 = 1400 \text{ kPa} \\ \text{sat. liquid} \end{array} \right\} h_3 = h_f @ 1400 \text{ kPa} = 127.22 \text{ kJ/kg}$$

$$h_4 \cong h_3 = 127.22 \text{ kJ/kg} \quad (\text{throttling})$$

$$\left. \begin{array}{l} T_5 = 8.9^\circ\text{C} \\ \text{sat. liquid} \end{array} \right\} h_5 = h_f @ 8.9^\circ\text{C} = 63.94 \text{ kJ/kg}$$

$$h_6 \cong h_5 = 63.94 \text{ kJ/kg} \quad (\text{throttling})$$

$$\left. \begin{array}{l} T_7 = -32^\circ\text{C} \\ \text{sat. vapor} \end{array} \right\} \begin{array}{l} h_7 = h_g @ -32^\circ\text{C} = 230.91 \text{ kJ/kg} \\ s_7 = s_g @ -32^\circ\text{C} = 0.95813 \text{ kJ/kg}\cdot\text{K} \end{array}$$

$$\left. \begin{array}{l} P_8 = P_{\text{sat}} @ 8.9^\circ\text{C} = 400 \text{ kPa} \\ s_8 = s_7 \end{array} \right\} h_8 = 264.51 \text{ kJ/kg}$$

An energy balance on the separator gives

$$\dot{m}_6(h_8 - h_5) = \dot{m}_2(h_1 - h_4) \longrightarrow \dot{m}_6 = \dot{m}_2 \frac{h_1 - h_4}{h_8 - h_5} = (2 \text{ kg/s}) \frac{255.55 - 127.22}{264.51 - 63.94} = 1.280 \text{ kg/s}$$

The rate of cooling produced by this system is then

$$\dot{Q}_L = \dot{m}_6(h_7 - h_6) = (1.280 \text{ kg/s})(230.91 - 63.94) \text{ kJ/kg} = \mathbf{213.7 \text{ kJ/s}}$$

The total power input to the compressors is

$$\begin{aligned} \dot{W}_{\text{in}} &= \dot{m}_6(h_8 - h_7) + \dot{m}_2(h_2 - h_1) \\ &= (1.280 \text{ kg/s})(264.51 - 230.91) \text{ kJ/kg} + (2 \text{ kg/s})(281.49 - 255.55) \text{ kJ/kg} = \mathbf{94.89 \text{ kW}} \end{aligned}$$

**11-111** A two-stage vapor-compression refrigeration system with refrigerant-134a as the working fluid is considered. The process with the greatest exergy destruction is to be determined.

**Assumptions** 1 Steady operating conditions exist. 2 Kinetic and potential energy changes are negligible.

**Analysis** From Prob. 11-109 and the refrigerant tables (Tables A-11, A-12, and A-13),

$$s_1 = s_2 = 0.92691 \text{ kJ/kg} \cdot \text{K}$$

$$s_3 = 0.45315 \text{ kJ/kg} \cdot \text{K}$$

$$s_4 = 0.4720 \text{ kJ/kg} \cdot \text{K}$$

$$s_5 = 0.24761 \text{ kJ/kg} \cdot \text{K}$$

$$s_6 = 0.2658 \text{ kJ/kg} \cdot \text{K}$$

$$s_7 = s_8 = 0.95813 \text{ kJ/kg} \cdot \text{K}$$

$$\dot{m}_{\text{upper}} = 2 \text{ kg/s}$$

$$\dot{m}_{\text{lower}} = 1.280 \text{ kg/s}$$

$$q_L = h_7 - h_6 = 166.97 \text{ kJ/kg}$$

$$q_H = h_2 - h_3 = 154.27 \text{ kJ/kg}$$

$$T_L = -18 + 273 = 255 \text{ K}$$

$$T_H = T_0 = 25 + 273 = 298 \text{ K}$$

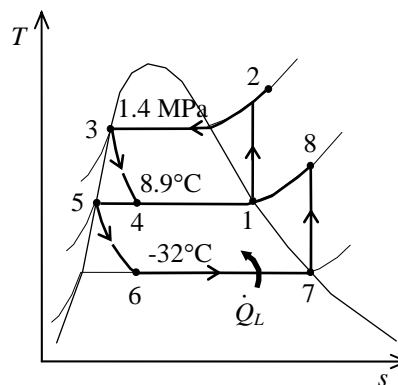

The exergy destruction during a process of a stream from an inlet state to exit state is given by

$$x_{\text{dest}} = T_0 s_{\text{gen}} = T_0 \left( s_e - s_i - \frac{q_{\text{in}}}{T_{\text{source}}} + \frac{q_{\text{out}}}{T_{\text{sink}}} \right)$$

Application of this equation for each process of the cycle gives

$$\begin{aligned} \dot{X}_{\text{destroyed},23} &= \dot{m}_{\text{upper}} T_0 \left( s_3 - s_2 + \frac{q_H}{T_H} \right) \\ &= (2 \text{ kg/s})(298 \text{ K}) \left( 0.45315 - 0.92691 + \frac{154.27 \text{ kJ/kg}}{298 \text{ K}} \right) = \mathbf{26.18 \text{ kW}} \end{aligned}$$

$$\dot{X}_{\text{destroyed},34} = \dot{m}_{\text{upper}} T_0 (s_4 - s_3) = (2 \text{ kg/s})(298 \text{ K})(0.4720 - 0.45315) \text{ kJ/kg} \cdot \text{K} = 11.23 \text{ kW}$$

$$\dot{X}_{\text{destroyed},56} = \dot{m}_{\text{lower}} T_0 (s_6 - s_5) = (1.280 \text{ kg/s})(298 \text{ K})(0.2658 - 0.24761) \text{ kJ/kg} \cdot \text{K} = 6.94 \text{ kW}$$

$$\begin{aligned} \dot{X}_{\text{destroyed},67} &= \dot{m}_{\text{lower}} T_0 \left( s_7 - s_6 - \frac{q_L}{T_L} \right) \\ &= (1.280 \text{ kg/s})(298 \text{ K}) \left( 0.95813 - 0.2658 - \frac{166.97 \text{ kJ/kg}}{255 \text{ K}} \right) = 14.32 \text{ kW} \end{aligned}$$

$$\begin{aligned} \dot{X}_{\text{destroyed},\text{separator}} &= T_0 \left[ \dot{m}_{\text{lower}} (s_5 - s_8) - \dot{m}_{\text{upper}} (s_1 - s_4) \right] \\ &= (298 \text{ K}) \left[ (1.280 \text{ kg/s})(0.24761 - 0.95813) + (2 \text{ kg/s})(0.92691 - 0.4720) \right] = 0.11 \text{ kW} \end{aligned}$$

For isentropic processes, the exergy destruction is zero:

$$\dot{X}_{\text{destroyed},12} = 0$$

$$\dot{X}_{\text{destroyed},78} = 0$$

Note that heat is absorbed from a reservoir at 0°F (460 R) and rejected to the standard ambient air at 77°F (537 R), which is also taken as the dead state temperature. The greatest exergy destruction occurs during the condensation process.

**11-112** A regenerative gas refrigeration cycle with helium as the working fluid is considered. The temperature of the helium at the turbine inlet, the COP of the cycle, and the net power input required are to be determined.

**Assumptions** 1 Steady operating conditions exist. 2 Helium is an ideal gas with constant specific heats at room temperature. 3 Kinetic and potential energy changes are negligible.

**Properties** The properties of helium are  $c_p = 5.1926$  kJ/kg·K and  $k = 1.667$  (Table A-2).

**Analysis** (a) The temperature of the helium at the turbine inlet is determined from an energy balance on the regenerator,

$$\begin{aligned}\dot{E}_{\text{in}} - \dot{E}_{\text{out}} &= \Delta \dot{E}_{\text{system}} \quad \phi^0(\text{steady}) = 0 \\ \dot{E}_{\text{in}} &= \dot{E}_{\text{out}} \\ \sum \dot{m}_e h_e &= \sum \dot{m}_i h_i \longrightarrow \dot{m}(h_3 - h_4) = \dot{m}(h_1 - h_6)\end{aligned}$$

or,

$$\dot{m}c_p(T_3 - T_4) = \dot{m}c_p(T_1 - T_6) \longrightarrow T_3 - T_4 = T_1 - T_6$$

Thus,

$$T_4 = T_3 - T_1 + T_6 = 20^\circ\text{C} - (-10^\circ\text{C}) + (-25^\circ\text{C}) = 5^\circ\text{C} = 278 \text{ K}$$

(b) From the isentropic relations,

$$\begin{aligned}T_2 &= T_1 \left( \frac{P_2}{P_1} \right)^{(k-1)/k} = (263 \text{ K})(3)^{0.667/1.667} = 408.2 \text{ K} = 135.2^\circ\text{C} \\ T_5 &= T_4 \left( \frac{P_5}{P_4} \right)^{(k-1)/k} = (278 \text{ K}) \left( \frac{1}{3} \right)^{0.667/1.667} = 179.1 \text{ K} = -93.9^\circ\text{C}\end{aligned}$$

Then the COP of this ideal gas refrigeration cycle is determined from

$$\begin{aligned}\text{COP}_R &= \frac{q_L}{w_{\text{net,in}}} = \frac{q_L}{w_{\text{comp,in}} - w_{\text{turb,out}}} = \frac{h_6 - h_5}{(h_2 - h_1) - (h_4 - h_5)} \\ &= \frac{T_6 - T_5}{(T_2 - T_1) - (T_4 - T_5)} = \frac{-25^\circ\text{C} - (-93.9^\circ\text{C})}{[135.2 - (-10)]^\circ\text{C} - [5 - (-93.9)]^\circ\text{C}} = \mathbf{1.49}\end{aligned}$$

(c) The net power input is determined from

$$\begin{aligned}\dot{W}_{\text{net,in}} &= \dot{W}_{\text{comp,in}} - \dot{W}_{\text{turb,out}} = \dot{m}[(h_2 - h_1) - (h_4 - h_5)] \\ &= \dot{m}c_p[(T_2 - T_1) - (T_4 - T_5)] \\ &= (0.45 \text{ kg/s})(5.1926 \text{ kJ/kg}\cdot^\circ\text{C})[(135.2 - (-10)) - [5 - (-93.9)]] \\ &= \mathbf{108.2 \text{ kW}}\end{aligned}$$

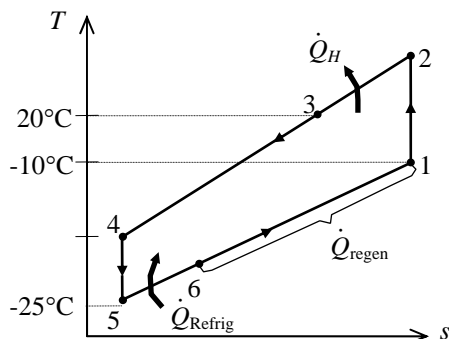

**11-113** An absorption refrigeration system operating at specified conditions is considered. The minimum rate of heat supply required is to be determined.

**Analysis** The maximum COP that this refrigeration system can have is

$$\text{COP}_{R,\max} = \left(1 - \frac{T_0}{T_s}\right) \left(\frac{T_L}{T_0 - T_L}\right) = \left(1 - \frac{298\text{K}}{358\text{K}}\right) \left(\frac{263}{298 - 263}\right) = 1.259$$

Thus,

$$\dot{Q}_{\text{gen},\min} = \frac{\dot{Q}_L}{\text{COP}_{R,\max}} = \frac{12 \text{ kW}}{1.259} = \mathbf{9.53 \text{ kW}}$$

**11-114 EES** Problem 11-113 is reconsidered. The effect of the source temperature on the minimum rate of heat supply is to be investigated.

**Analysis** The problem is solved using EES, and the solution is given below.

"Input Data:"

T\_L = -10 [C]

T\_0 = 25 [C]

T\_s = 85 [C]

Q\_dot\_L = 8 [kW]

"The maximum COP that this refrigeration system can have is:"

$\text{COP}_{R,\max} = (1 - (T_0 + 273)/(T_s + 273)) * ((T_L + 273)/(T_0 - T_L))$

"The minimum rate of heat supply is:"

$Q_{\text{dot\_gen\_min}} = Q_{\text{dot\_L}} / \text{COP}_{R,\max}$

$Q_{\text{gen,min}}$ [kW]	$T_s$ [C]
13.76	50
8.996	65
6.833	80
5.295	100
4.237	125
3.603	150
2.878	200
2.475	250

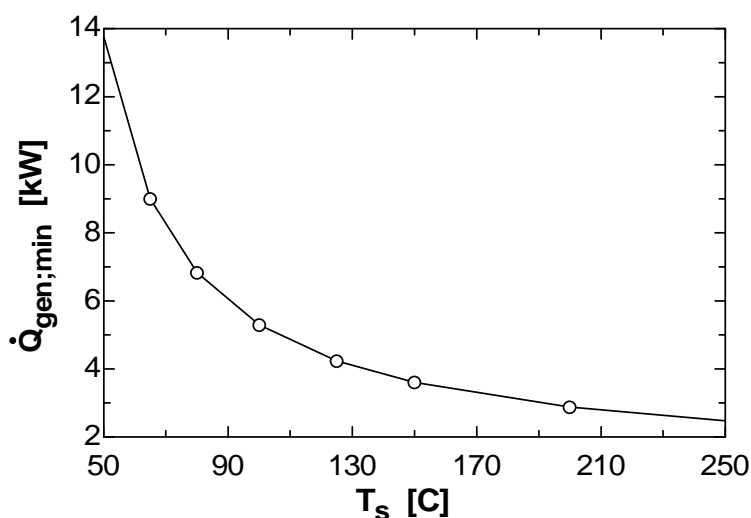

**11-115** A room is cooled adequately by a 5000 Btu/h window air-conditioning unit. The rate of heat gain of the room when the air-conditioner is running continuously is to be determined.

**Assumptions** **1** The heat gain includes heat transfer through the walls and the roof, infiltration heat gain, solar heat gain, internal heat gain, etc. **2** Steady operating conditions exist.

**Analysis** The rate of heat gain of the room in steady operation is simply equal to the cooling rate of the air-conditioning system,

$$\dot{Q}_{\text{heat gain}} = \dot{Q}_{\text{cooling}} = \mathbf{5,000 \text{ Btu/h}}$$

**11-116** A regenerative gas refrigeration cycle using air as the working fluid is considered. The effectiveness of the regenerator, the rate of heat removal from the refrigerated space, the COP of the cycle, and the refrigeration load and the COP if this system operated on the simple gas refrigeration cycle are to be determined.

**Assumptions** 1 Steady operating conditions exist. 2 Kinetic and potential energy changes are negligible. 3 Air is an ideal gas with variable specific heats.

**Analysis** (a) For this problem, we use the properties of air from EES:

$$\begin{aligned} T_1 = 0^\circ\text{C} &\longrightarrow h_1 = 273.40 \text{ kJ/kg} \\ P_1 = 100 \text{ kPa} \\ T_1 = 0^\circ\text{C} &\left. \vphantom{\begin{array}{l} T_1 = 0^\circ\text{C} \\ P_1 = 100 \text{ kPa} \end{array}} \right\} s_1 = 5.6110 \text{ kJ/kg}\cdot\text{K} \\ P_2 = 500 \text{ kPa} \\ s_2 = s_1 &\left. \vphantom{\begin{array}{l} P_2 = 500 \text{ kPa} \\ s_2 = s_1 \end{array}} \right\} h_{2s} = 433.50 \text{ kJ/kg} \end{aligned}$$

$$\eta_C = \frac{h_{2s} - h_1}{h_2 - h_1}$$

$$0.80 = \frac{433.50 - 273.40}{h_2 - 273.40}$$

$$h_2 = 473.52 \text{ kJ/kg}$$

$$T_3 = 35^\circ\text{C} \longrightarrow h_3 = 308.63 \text{ kJ/kg}$$

For the turbine inlet and exit we have

$$T_5 = -80^\circ\text{C} \longrightarrow h_5 = 193.45 \text{ kJ/kg}$$

$$T_4 = ? \longrightarrow h_4 =$$

$$\eta_T = \frac{h_4 - h_5}{h_4 - h_{5s}}$$

$$\begin{aligned} P_1 = 100 \text{ kPa} \\ T_1 = 0^\circ\text{C} &\left. \vphantom{\begin{array}{l} P_1 = 100 \text{ kPa} \\ T_1 = 0^\circ\text{C} \end{array}} \right\} s_1 = 5.6110 \text{ kJ/kg}\cdot\text{K} \end{aligned}$$

$$\begin{aligned} P_4 = 500 \text{ kPa} \\ T_4 = ? &\left. \vphantom{\begin{array}{l} P_4 = 500 \text{ kPa} \\ T_4 = ? \end{array}} \right\} s_4 = \end{aligned}$$

$$\begin{aligned} P_5 = 500 \text{ kPa} \\ s_5 = s_4 &\left. \vphantom{\begin{array}{l} P_5 = 500 \text{ kPa} \\ s_5 = s_4 \end{array}} \right\} h_{5s} = \end{aligned}$$

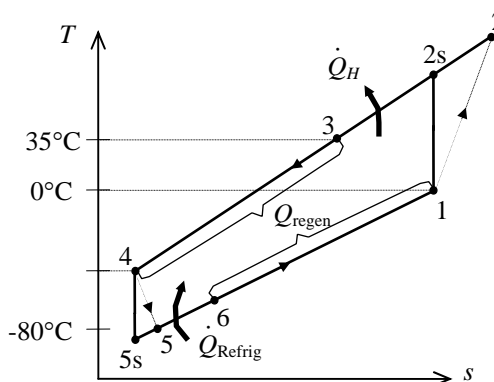
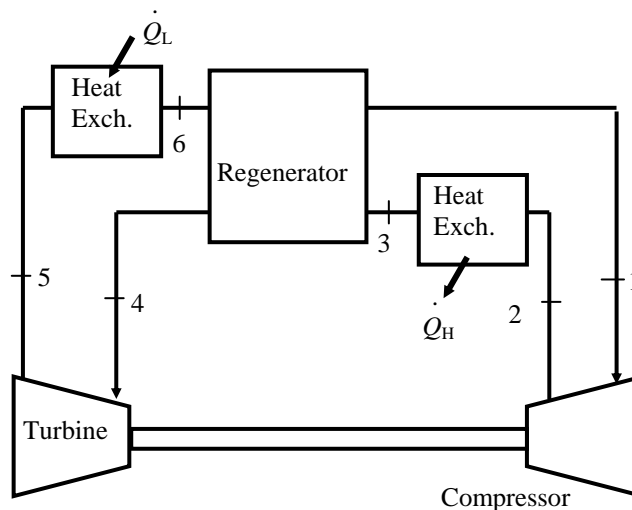

We can determine the temperature at the turbine inlet from EES using the above relations. A hand solution would require a trial-error approach.

$$T_4 = 281.8 \text{ K}, \quad h_4 = 282.08 \text{ kJ/kg}$$

An energy balance on the regenerator gives

$$h_6 = h_1 - h_3 + h_4 = 273.40 - 308.63 + 282.08 = 246.85 \text{ kJ/kg}$$

The effectiveness of the regenerator is determined from

$$\varepsilon_{\text{regen}} = \frac{h_3 - h_4}{h_3 - h_6} = \frac{308.63 - 282.08}{308.63 - 246.85} = \mathbf{0.430}$$



(b) The refrigeration load is

$$\dot{Q}_L = \dot{m}(h_6 - h_5) = (0.4 \text{ kg/s})(246.85 - 193.45) \text{ kJ/kg} = \mathbf{21.36 \text{ kW}}$$

(c) The turbine and compressor powers and the COP of the cycle are

$$\dot{W}_{C,\text{in}} = \dot{m}(h_2 - h_1) = (0.4 \text{ kg/s})(473.52 - 273.40) \text{ kJ/kg} = 80.05 \text{ kW}$$

$$\dot{W}_{T,\text{out}} = \dot{m}(h_4 - h_5) = (0.4 \text{ kg/s})(282.08 - 193.45) \text{ kJ/kg} = 35.45 \text{ kW}$$

$$\text{COP} = \frac{\dot{Q}_L}{\dot{W}_{\text{net,in}}} = \frac{\dot{Q}_L}{\dot{W}_{C,\text{in}} - \dot{W}_{T,\text{out}}} = \frac{21.36}{80.05 - 35.45} = \mathbf{0.479}$$

(d) The simple gas refrigeration cycle analysis is as follows:

$$h_1 = 273.40 \text{ kJ/kg}$$

$$h_2 = 473.52 \text{ kJ/kg}$$

$$h_3 = 308.63 \text{ kJ/kg}$$

$$\left. \begin{array}{l} P_3 = 500 \text{ kPa} \\ T_3 = 35^\circ\text{C} \end{array} \right\} s_3 = 5.2704 \text{ kJ/kg}$$

$$\left. \begin{array}{l} P_1 = 100 \text{ kPa} \\ s_4 = s_3 \end{array} \right\} h_{4s} = 194.52 \text{ kJ/kg.K}$$

$$\eta_T = \frac{h_3 - h_4}{h_3 - h_{4s}} \longrightarrow 0.85 = \frac{308.63 - h_4}{308.63 - 194.52} \longrightarrow h_4 = 211.64 \text{ kJ/kg}$$

$$\dot{Q}_L = \dot{m}(h_1 - h_4) = (0.4 \text{ kg/s})(273.40 - 211.64) \text{ kJ/kg} = \mathbf{24.70 \text{ kW}}$$

$$\dot{W}_{\text{net,in}} = \dot{m}(h_2 - h_1) - \dot{m}(h_3 - h_4) = (0.4 \text{ kg/s})[(473.52 - 273.40) - (308.63 - 211.64) \text{ kJ/kg}] = 41.25 \text{ kW}$$

$$\text{COP} = \frac{\dot{Q}_L}{\dot{W}_{\text{net,in}}} = \frac{24.70}{41.25} = \mathbf{0.599}$$

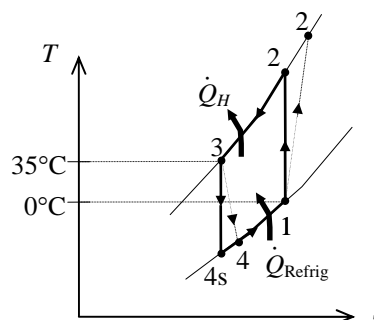

**11-117** A heat pump water heater has a COP of 2.2 and consumes 2 kW when running. It is to be determined if this heat pump can be used to meet the cooling needs of a room by absorbing heat from it.

**Assumptions** The COP of the heat pump remains constant whether heat is absorbed from the outdoor air or room air.

**Analysis** The COP of the heat pump is given to be 2.2. Then the COP of the air-conditioning system becomes

$$\text{COP}_{\text{air-cond}} = \text{COP}_{\text{heat pump}} - 1 = 2.2 - 1 = 1.2$$

Then the rate of cooling (heat absorption from the air) becomes

$$\dot{Q}_{\text{cooling}} = \text{COP}_{\text{air-cond}} \dot{W}_{\text{in}} = (1.2)(2 \text{ kW}) = 2.4 \text{ kW} = 8640 \text{ kJ/h}$$

since  $1 \text{ kW} = 3600 \text{ kJ/h}$ . We conclude that this heat pump **can meet** the cooling needs of the room since its cooling rate is greater than the rate of heat gain of the room.

**11-118** An innovative vapor-compression refrigeration system with a heat exchanger is considered. The system's COP is to be determined.

**Assumptions** 1 Steady operating conditions exist. 2 Kinetic and potential energy changes are negligible.

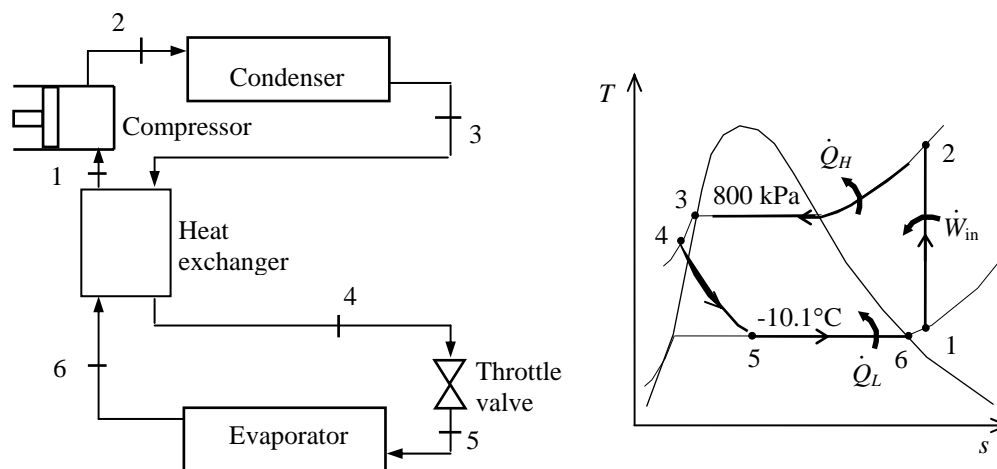

**Analysis** From the refrigerant tables (Tables A-11, A-12, and A-13),

$$\left. \begin{array}{l} P_3 = 800 \text{ kPa} \\ \text{sat. liquid} \end{array} \right\} h_3 = h_f @ 800 \text{ kPa} = 95.47 \text{ kJ/kg}$$

$$\left. \begin{array}{l} T_4 = T_{\text{sat}} @ 800 \text{ kPa} - 11.3 \\ = 31.3 - 11.3 = 20^\circ\text{C} \\ P_4 = 800 \text{ kPa} \end{array} \right\} h_4 \cong h_f @ 20^\circ\text{C} = 79.32 \text{ kJ/kg}$$

$$h_5 \cong h_4 = 79.32 \text{ kJ/kg} \quad (\text{throttling})$$

$$\left. \begin{array}{l} T_6 = -10.1^\circ\text{C} \\ \text{sat. vapor} \end{array} \right\} \begin{array}{l} h_6 = h_g @ -10.1^\circ\text{C} = 244.46 \text{ kJ/kg} \\ P_6 = P_{\text{sat}} @ -10.1^\circ\text{C} = 200 \text{ kPa} \end{array}$$

An energy balance on the heat exchanger gives

$$\dot{m}(h_1 - h_6) = \dot{m}(h_3 - h_4) \longrightarrow h_1 = h_3 - h_4 + h_6 = 95.47 - 79.32 + 244.46 = 260.61 \text{ kJ/kg}$$

Then,

$$\left. \begin{array}{l} P_1 = 200 \text{ kPa} \\ h_1 = 260.61 \text{ kJ/kg} \end{array} \right\} s_1 = 0.9970 \text{ kJ/kg} \cdot \text{K}$$

$$\left. \begin{array}{l} P_2 = 800 \text{ kPa} \\ s_2 = s_1 \end{array} \right\} h_2 = 292.17 \text{ kJ/kg}$$

The COP of this refrigeration system is determined from its definition,

$$\text{COP}_R = \frac{q_L}{w_{\text{in}}} = \frac{h_6 - h_5}{h_2 - h_1} = \frac{244.46 - 79.32}{292.17 - 260.61} = \mathbf{5.23}$$

**11-119** An innovative vapor-compression refrigeration system with a heat exchanger is considered. The system's COP is to be determined.

**Assumptions** 1 Steady operating conditions exist. 2 Kinetic and potential energy changes are negligible.

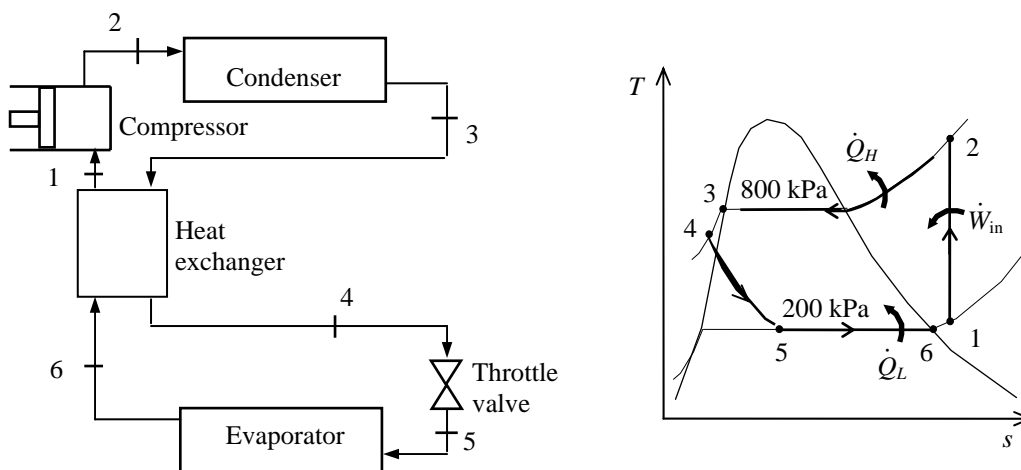

**Analysis** From the refrigerant tables (Tables A-11, A-12, and A-13),

$$\left. \begin{array}{l} P_3 = 800 \text{ kPa} \\ \text{sat. liquid} \end{array} \right\} h_3 = h_f @ 800 \text{ kPa} = 95.47 \text{ kJ/kg}$$

$$\left. \begin{array}{l} T_4 = T_{\text{sat}} @ 800 \text{ kPa} - 21.3 \\ = 31.3 - 21.3 = 10^\circ\text{C} \\ P_4 = 800 \text{ kPa} \end{array} \right\} h_4 \cong h_f @ 10^\circ\text{C} = 65.43 \text{ kJ/kg}$$

$$h_5 \cong h_4 = 65.43 \text{ kJ/kg} \quad (\text{throttling})$$

$$\left. \begin{array}{l} T_6 = -10.1^\circ\text{C} \\ \text{sat. vapor} \end{array} \right\} \begin{array}{l} h_6 = h_g @ -10.1^\circ\text{C} = 244.46 \text{ kJ/kg} \\ P_6 = P_{\text{sat}} @ -10.1^\circ\text{C} = 200 \text{ kPa} \end{array}$$

An energy balance on the heat exchanger gives

$$\dot{m}(h_1 - h_6) = \dot{m}(h_3 - h_4) \longrightarrow h_1 = h_3 - h_4 + h_6 = 95.47 - 65.43 + 244.46 = 274.50 \text{ kJ/kg}$$

Then,

$$\left. \begin{array}{l} P_1 = 200 \text{ kPa} \\ h_1 = 274.50 \text{ kJ/kg} \end{array} \right\} s_1 = 1.0449 \text{ kJ/kg} \cdot \text{K}$$

$$\left. \begin{array}{l} P_2 = 800 \text{ kPa} \\ s_2 = s_1 \end{array} \right\} h_2 = 308.28 \text{ kJ/kg}$$

The COP of this refrigeration system is determined from its definition,

$$\text{COP}_R = \frac{q_L}{w_{in}} = \frac{h_6 - h_5}{h_2 - h_1} = \frac{244.46 - 65.43}{308.28 - 274.50} = \mathbf{5.30}$$

**11-120** An ideal gas refrigeration cycle with with three stages of compression with intercooling using air as the working fluid is considered. The COP of this system is to be determined.

**Assumptions 1** Steady operating conditions exist. **2** Air is an ideal gas with constant specific heats. **3** Kinetic and potential energy changes are negligible.

**Properties** The properties of air at room temperature are  $c_p = 1.005 \text{ kJ/kg}\cdot\text{K}$  and  $k = 1.4$  (Table A-2a).

**Analysis** From the isentropic relations,

$$T_2 = T_1 \left( \frac{P_2}{P_1} \right)^{(k-1)/k} = (253 \text{ K})(5)^{0.4/1.4} = 400.7 \text{ K}$$

$$T_4 = T_6 = T_3 \left( \frac{P_4}{P_3} \right)^{(k-1)/k} = (288 \text{ K})(5)^{0.4/1.4} = 456.1 \text{ K}$$

$$T_8 = T_7 \left( \frac{P_8}{P_7} \right)^{(k-1)/k} = (288 \text{ K}) \left( \frac{1}{5 \times 5 \times 5} \right)^{0.4/1.4} = 72.5 \text{ K}$$

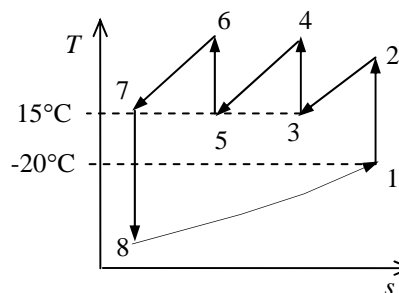

The COP of this ideal gas refrigeration cycle is determined from

$$\begin{aligned} \text{COP}_R &= \frac{q_L}{w_{\text{net,in}}} = \frac{q_L}{w_{\text{comp,in}} - w_{\text{turb,out}}} \\ &= \frac{h_1 - h_8}{(h_2 - h_1) + (h_4 - h_3) + (h_6 - h_5) - (h_7 - h_8)} \\ &= \frac{T_1 - T_8}{(T_2 - T_1) + 2(T_4 - T_3) - (T_7 - T_8)} \\ &= \frac{253 - 72.5}{(400.7 - 253) + 2(456.1 - 288) - (288 - 72.5)} = \mathbf{0.673} \end{aligned}$$

**11-121** An ideal vapor-compression refrigeration cycle with refrigerant-22 as the working fluid is considered. The evaporator is located inside the air handler of building. The hardware and the T-s diagram for this heat pump application are to be sketched. The COP of the unit and the ratio of volume flow rate of air entering the air handler to mass flow rate of R-22 through the air handler are to be determined.

**Assumptions** 1 Steady operating conditions exist. 2 Kinetic and potential energy changes are negligible.

**Analysis** (a) In an ideal vapor-compression refrigeration cycle, the compression process is isentropic, the refrigerant enters the compressor as a saturated vapor at the evaporator pressure, and leaves the condenser as saturated liquid at the condenser pressure. From the refrigerant-22 data from the problem statement,

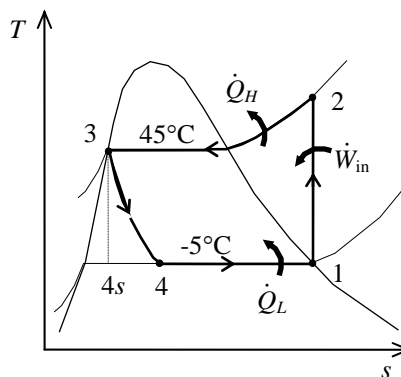
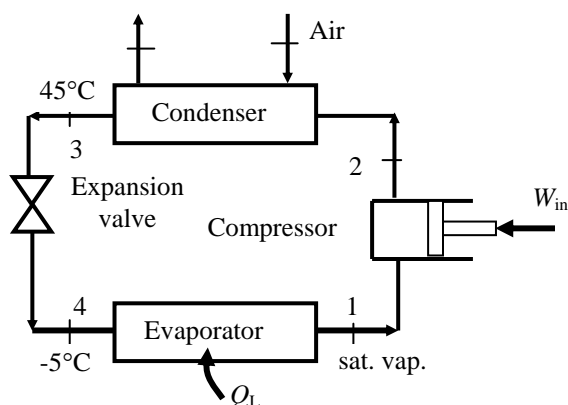

$$\left. \begin{array}{l} T_1 = -5^\circ\text{C} \\ \text{sat. vapor} \end{array} \right\} \begin{array}{l} h_1 = h_g @ -5^\circ\text{C} = 248.1 \text{ kJ/kg} \\ s_1 = s_g @ -5^\circ\text{C} = 0.9344 \text{ kJ/kg}\cdot\text{K} \end{array}$$

$$\left. \begin{array}{l} P_2 = 1728 \text{ kPa} \\ s_2 = s_1 \end{array} \right\} h_2 = 283.7 \text{ kJ/kg}$$

$$\left. \begin{array}{l} P_3 = 1728 \text{ kPa} \\ \text{sat. liquid} \end{array} \right\} h_3 = h_f @ 1728 \text{ kPa} = 101 \text{ kJ/kg}$$

$$h_4 \cong h_3 = 101 \text{ kJ/kg} \quad (\text{throttling})$$

(b) The COP of the heat pump is determined from its definition,

$$\text{COP}_{\text{HP}} = \frac{q_H}{w_{\text{in}}} = \frac{h_2 - h_3}{h_2 - h_1} = \frac{283.7 - 101}{283.7 - 248.1} = \mathbf{5.13}$$

(c) An energy balance on the condenser gives

$$\dot{Q}_H = \dot{m}_R (h_2 - h_3) = \dot{m}_a c_p \Delta T = \frac{\dot{V}_a}{\nu_a} c_p \Delta T$$

Rearranging, we obtain the ratio of volume flow rate of air entering the air handler to mass flow rate of R-22 through the air handler

$$\begin{aligned} \frac{\dot{V}_a}{\dot{m}_R} &= \frac{h_2 - h_3}{(1/\nu)c_p \Delta T} = \frac{(283.7 - 101) \text{ kJ/kg}}{(1/0.847 \text{ m}^3/\text{kg})(1.005 \text{ kJ/kg}\cdot\text{K})(20 \text{ K})} \\ &= 7.699 \text{ (m}^3 \text{ air/s)/(kg R22/s)} \\ &= \mathbf{462 \text{ (m}^3 \text{ air/min)/(kg R22/s)}} \end{aligned}$$

Note that the specific volume of air is obtained from ideal gas equation taking the pressure of air to be 101 kPa and using the room temperature of air ( $25^\circ\text{C} = 298 \text{ K}$ ) to be  $0.847 \text{ m}^3/\text{kg}$ .

**11-122** An ideal vapor-compression refrigeration cycle with refrigerant-134a as the working fluid is considered. Cooling water flows through the water jacket surrounding the condenser. To produce ice, potable water is supplied to the chiller section of the refrigeration cycle. The hardware and the T-s diagram for this refrigerant-ice making system are to be sketched. The mass flow rates of the refrigerant and the potable water are to be determined.

**Assumptions** 1 Steady operating conditions exist. 2 Kinetic and potential energy changes are negligible.

**Analysis** (a) In an ideal vapor-compression refrigeration cycle, the compression process is isentropic, the refrigerant enters the compressor as a saturated vapor at the evaporator pressure, and leaves the condenser as saturated liquid at the condenser pressure. From the refrigerant-134a data from the problem statement,

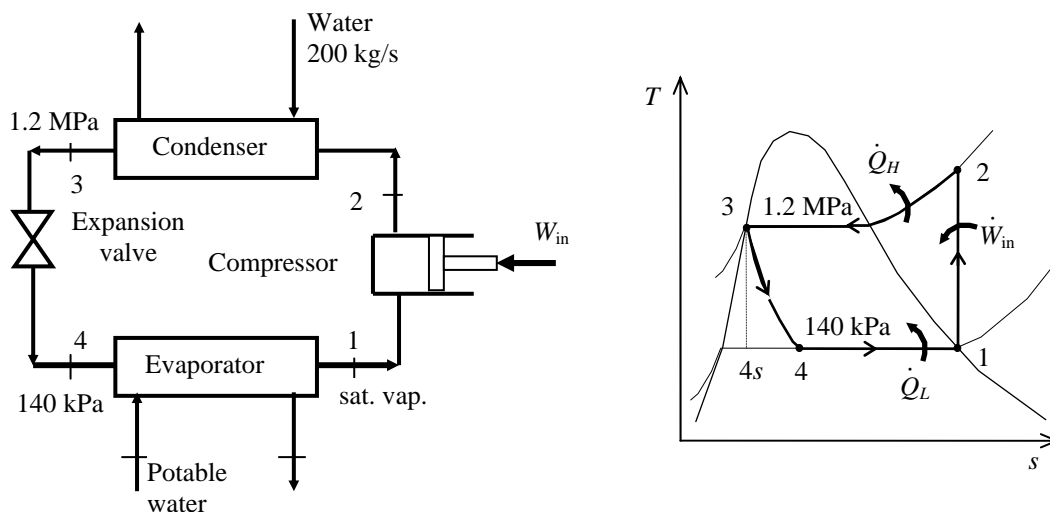

$$\left. \begin{array}{l} T_1 = 140 \text{ kPa} \\ \text{sat. vapor} \end{array} \right\} \begin{array}{l} h_1 = h_g @ 140 \text{ kPa} = 239.16 \text{ kJ/kg} \\ s_1 = s_g @ 140 \text{ kPa} = 0.94456 \text{ kJ/kg} \cdot \text{K} \end{array}$$

$$\left. \begin{array}{l} P_2 = 1200 \text{ kPa} \\ s_2 = s_1 \end{array} \right\} h_2 = 284.07 \text{ kJ/kg}$$

$$\left. \begin{array}{l} P_3 = 1200 \text{ kPa} \\ \text{sat. liquid} \end{array} \right\} h_3 = h_f @ 1200 \text{ kPa} = 117.77 \text{ kJ/kg}$$

$$h_4 \cong h_3 = 117.77 \text{ kJ/kg} \quad (\text{throttling})$$

(b) An energy balance on the condenser gives

$$\dot{Q}_H = \dot{m}_R (h_2 - h_3) = \dot{m}_w c_p \Delta T$$

Solving for the mass flow rate of the refrigerant

$$\dot{m}_R = \frac{\dot{m}_w c_p \Delta T}{h_2 - h_3} = \frac{(200 \text{ kg/s})(4.18 \text{ kJ/kg} \cdot \text{K})(10 \text{ K})}{(284.07 - 117.77) \text{ kJ/kg}} = \mathbf{50.3 \text{ kg/s}}$$

(c) An energy balance on the evaporator gives

$$\dot{Q}_L = \dot{m}_R (h_1 - h_4) = \dot{m}_w h_{if}$$

Solving for the mass flow rate of the potable water

$$\dot{m}_w = \frac{\dot{m}_R (h_1 - h_4)}{h_{if}} = \frac{(50.3 \text{ kg/s})(239.16 - 117.77) \text{ kJ/kg}}{333 \text{ kJ/kg}} = \mathbf{18.3 \text{ kg/s}}$$

**11-123** A vortex tube receives compressed air at 500 kPa and 300 K, and supplies 25 percent of it as cold air and the rest as hot air. The COP of the vortex tube is to be compared to that of a reversed Brayton cycle for the same pressure ratio; the exit temperature of the hot fluid stream and the COP are to be determined; and it is to be shown if this process violates the second law.

**Assumptions** **1** The vortex tube is adiabatic. **2** Air is an ideal gas with constant specific heats at room temperature. **3** Steady operating conditions exist.

**Properties** The gas constant of air is 0.287 kJ/kg.K (Table A-1). The specific heat of air at room temperature is  $c_p = 1.005$  kJ/kg.K (Table A-2). The enthalpy of air at absolute temperature  $T$  can be expressed in terms of specific heats as  $h = c_p T$ .

**Analysis** (a) The COP of the vortex tube is much lower than the COP of a reversed Brayton cycle of the same pressure ratio since the vortex tube involves *vortices*, which are highly irreversible. Owing to this irreversibility, the minimum temperature that can be obtained by the vortex tube is not as low as the one that can be obtained by the reversed Brayton cycle.

(b) We take the vortex tube as the system. This is a steady flow system with one inlet and two exits, and it involves no heat or work interactions. Then the steady-flow energy balance equation for this system

$\dot{E}_{\text{in}} = \dot{E}_{\text{out}}$  for a unit mass flow rate at the inlet ( $\dot{m}_1 = 1$  kg/s) can be expressed as

$$\begin{aligned}\dot{m}_1 h_1 &= \dot{m}_2 h_2 + \dot{m}_3 h_3 \\ \dot{m}_1 c_p T_1 &= \dot{m}_2 c_p T_2 + \dot{m}_3 c_p T_3 \\ 1c_p T_1 &= 0.25c_p T_2 + 0.75c_p T_3\end{aligned}$$

Canceling  $c_p$  and solving for  $T_3$  gives

$$\begin{aligned}T_3 &= \frac{T_1 - 0.25T_2}{0.75} \\ &= \frac{300 - 0.25 \times 278}{0.75} = \mathbf{307.3 \text{ K}}\end{aligned}$$

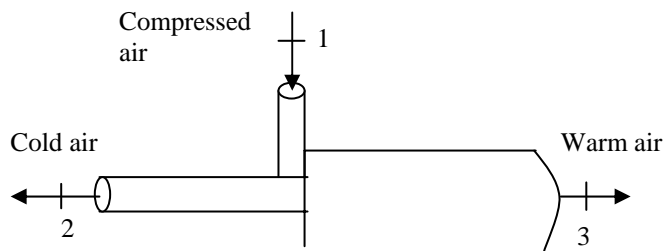

Therefore, the hot air stream will leave the vortex tube at an average temperature of 307.3 K.

(c) The entropy balance for this steady flow system  $\dot{S}_{\text{in}} - \dot{S}_{\text{out}} + \dot{S}_{\text{gen}} = 0$  can be expressed as with one inlet and two exits, and it involves no heat or work interactions. Then the steady-flow entropy balance equation for this system for a unit mass flow rate at the inlet ( $\dot{m}_1 = 1$  kg/s) can be expressed

$$\begin{aligned}\dot{S}_{\text{gen}} &= \dot{S}_{\text{out}} - \dot{S}_{\text{in}} \\ &= \dot{m}_2 s_2 + \dot{m}_3 s_3 - \dot{m}_1 s_1 = \dot{m}_2 s_2 + \dot{m}_3 s_3 - (\dot{m}_2 + \dot{m}_3) s_1 \\ &= \dot{m}_2 (s_2 - s_1) + \dot{m}_3 (s_3 - s_1) \\ &= 0.25(s_2 - s_1) + 0.75(s_3 - s_1) \\ &= 0.25 \left( c_p \ln \frac{T_2}{T_1} - R \ln \frac{P_2}{P_1} \right) + 0.75 \left( c_p \ln \frac{T_3}{T_1} - R \ln \frac{P_3}{P_1} \right)\end{aligned}$$

Substituting the known quantities, the rate of entropy generation is determined to be

$$\begin{aligned}\dot{S}_{\text{gen}} &= 0.25 \left( (1.005 \text{ kJ/kg.K}) \ln \frac{278 \text{ K}}{300 \text{ K}} - (0.287 \text{ kJ/kg.K}) \ln \frac{100 \text{ kPa}}{500 \text{ kPa}} \right) \\ &\quad + 0.75 \left( (1.005 \text{ kJ/kg.K}) \ln \frac{307.3 \text{ K}}{300 \text{ K}} - (0.287 \text{ kJ/kg.K}) \ln \frac{100 \text{ kPa}}{500 \text{ kPa}} \right) \\ &= 0.461 \text{ kW/K} > 0\end{aligned}$$

which is a positive quantity. Therefore, this process **satisfies** the 2<sup>nd</sup> law of thermodynamics.



(d) For a unit mass flow rate at the inlet ( $\dot{m}_1 = 1 \text{ kg/s}$ ), the cooling rate and the power input to the compressor are determined to

$$\begin{aligned}\dot{Q}_{\text{cooling}} &= \dot{m}_c (h_1 - h_c) = \dot{m}_c c_p (T_1 - T_c) \\ &= (0.25 \text{ kg/s})(1.005 \text{ kJ/kg}\cdot\text{K})(300 - 278)\text{K} = 5.53 \text{ kW} \\ \dot{W}_{\text{comp,in}} &= \frac{\dot{m}_0 R T_0}{(k-1)\eta_{\text{comp}}} \left[ \left( \frac{P_1}{P_0} \right)^{(k-1)/k} - 1 \right] \\ &= \frac{(1 \text{ kg/s})(0.287 \text{ kJ/kg}\cdot\text{K})(300 \text{ K})}{(1.4-1)0.80} \left[ \left( \frac{500 \text{ kPa}}{100 \text{ kPa}} \right)^{(1.4-1)/1.4} - 1 \right] = 157.1 \text{ kW}\end{aligned}$$

Then the COP of the vortex refrigerator becomes

$$\text{COP} = \frac{\dot{Q}_{\text{cooling}}}{\dot{W}_{\text{comp,in}}} = \frac{5.53 \text{ kW}}{157.1 \text{ kW}} = \mathbf{0.035}$$

The COP of a Carnot refrigerator operating between the same temperature limits of 300 K and 278 K is

$$\text{COP}_{\text{Carnot}} = \frac{T_L}{T_H - T_L} = \frac{278 \text{ K}}{(300 - 278) \text{ K}} = \mathbf{12.6}$$

**Discussion** Note that the COP of the vortex refrigerator is a small fraction of the COP of a Carnot refrigerator operating between the same temperature limits.

**11-124** A vortex tube receives compressed air at 600 kPa and 300 K, and supplies 25 percent of it as cold air and the rest as hot air. The COP of the vortex tube is to be compared to that of a reversed Brayton cycle for the same pressure ratio; the exit temperature of the hot fluid stream and the COP are to be determined; and it is to be shown if this process violates the second law.

**Assumptions** **1** The vortex tube is adiabatic. **2** Air is an ideal gas with constant specific heats at room temperature. **3** Steady operating conditions exist.

**Properties** The gas constant of air is 0.287 kJ/kg.K (Table A-1). The specific heat of air at room temperature is  $c_p = 1.005$  kJ/kg.K (Table A-2). The enthalpy of air at absolute temperature  $T$  can be expressed in terms of specific heats as  $h = c_p T$ .

**Analysis** (a) The COP of the vortex tube is much lower than the COP of a reversed Brayton cycle of the same pressure ratio since the vortex tube involves *vortices*, which are highly irreversible. Owing to this irreversibility, the minimum temperature that can be obtained by the vortex tube is not as low as the one that can be obtained by the reversed Brayton cycle.

(b) We take the vortex tube as the system. This is a steady flow system with one inlet and two exits, and it involves no heat or work interactions. Then the steady-flow entropy balance equation for this system

$\dot{E}_{\text{in}} = \dot{E}_{\text{out}}$  for a unit mass flow rate at the inlet ( $\dot{m}_1 = 1$  kg/s) can be expressed as

$$\begin{aligned}\dot{m}_1 h_1 &= \dot{m}_2 h_2 + \dot{m}_3 h_3 \\ \dot{m}_1 c_p T_1 &= \dot{m}_2 c_p T_2 + \dot{m}_3 c_p T_3 \\ 1 c_p T_1 &= 0.25 c_p T_2 + 0.75 c_p T_3\end{aligned}$$

Canceling  $c_p$  and solving for  $T_3$  gives

$$\begin{aligned}T_3 &= \frac{T_1 - 0.25T_2}{0.75} \\ &= \frac{300 - 0.25 \times 278}{0.75} = \mathbf{307.3 \text{ K}}\end{aligned}$$

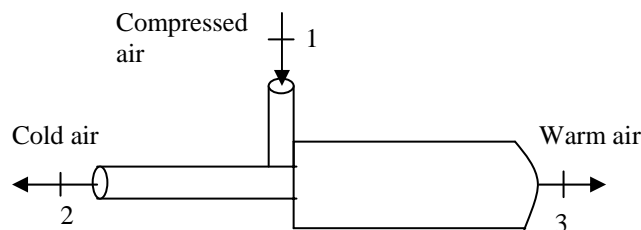

Therefore, the hot air stream will leave the vortex tube at an average temperature of 307.3 K.

(c) The entropy balance for this steady flow system  $\dot{S}_{\text{in}} - \dot{S}_{\text{out}} + \dot{S}_{\text{gen}} = 0$  can be expressed as with one inlet and two exits, and it involves no heat or work interactions. Then the steady-flow energy balance equation for this system for a unit mass flow rate at the inlet ( $\dot{m}_1 = 1$  kg/s) can be expressed

$$\begin{aligned}\dot{S}_{\text{gen}} &= \dot{S}_{\text{out}} - \dot{S}_{\text{in}} \\ &= \dot{m}_2 s_2 + \dot{m}_3 s_3 - \dot{m}_1 s_1 = \dot{m}_2 s_2 + \dot{m}_3 s_3 - (\dot{m}_2 + \dot{m}_3) s_1 \\ &= \dot{m}_2 (s_2 - s_1) + \dot{m}_3 (s_3 - s_1) \\ &= 0.25(s_2 - s_1) + 0.75(s_3 - s_1) \\ &= 0.25 \left( c_p \ln \frac{T_2}{T_1} - R \ln \frac{P_2}{P_1} \right) + 0.75 \left( c_p \ln \frac{T_3}{T_1} - R \ln \frac{P_3}{P_1} \right)\end{aligned}$$

Substituting the known quantities, the rate of entropy generation is determined to be

$$\begin{aligned}\dot{S}_{\text{gen}} &= 0.25 \left( (1.005 \text{ kJ/kg.K}) \ln \frac{278 \text{ K}}{300 \text{ K}} - (0.287 \text{ kJ/kg.K}) \ln \frac{100 \text{ kPa}}{600 \text{ kPa}} \right) \\ &\quad + 0.75 \left( (1.005 \text{ kJ/kg.K}) \ln \frac{307.3 \text{ K}}{300 \text{ K}} - (0.287 \text{ kJ/kg.K}) \ln \frac{100 \text{ kPa}}{600 \text{ kPa}} \right) \\ &= 0.513 \text{ kW/K} > 0\end{aligned}$$

which is a positive quantity. Therefore, this process **satisfies** the 2<sup>nd</sup> law of thermodynamics.

(d) For a unit mass flow rate at the inlet ( $\dot{m}_1 = 1 \text{ kg/s}$ ), the cooling rate and the power input to the compressor are determined to

$$\begin{aligned}\dot{Q}_{\text{cooling}} &= \dot{m}_c (h_1 - h_c) = \dot{m}_c c_p (T_1 - T_c) \\ &= (0.25 \text{ kg/s})(1.005 \text{ kJ/kg}\cdot\text{K})(300 - 278)\text{K} = 5.53 \text{ kW} \\ \dot{W}_{\text{comp,in}} &= \frac{\dot{m}_0 R T_0}{(k-1)\eta_{\text{comp}}} \left[ \left( \frac{P_1}{P_0} \right)^{(k-1)/k} - 1 \right] \\ &= \frac{(1 \text{ kg/s})(0.287 \text{ kJ/kg}\cdot\text{K})(300 \text{ K})}{(1.4-1)0.80} \left[ \left( \frac{600 \text{ kPa}}{100 \text{ kPa}} \right)^{(1.4-1)/1.4} - 1 \right] = 179.9 \text{ kW}\end{aligned}$$

Then the COP of the vortex refrigerator becomes

$$\text{COP} = \frac{\dot{Q}_{\text{cooling}}}{\dot{W}_{\text{comp,in}}} = \frac{5.53 \text{ kW}}{179.9 \text{ kW}} = \mathbf{0.031}$$

The COP of a Carnot refrigerator operating between the same temperature limits of 300 K and 278 K is

$$\text{COP}_{\text{Carnot}} = \frac{T_L}{T_H - T_L} = \frac{278 \text{ K}}{(300 - 278) \text{ K}} = \mathbf{12.6}$$

**Discussion** Note that the COP of the vortex refrigerator is a small fraction of the COP of a Carnot refrigerator operating between the same temperature limits.

**11-125 EES** The effect of the evaporator pressure on the COP of an ideal vapor-compression refrigeration cycle with R-134a as the working fluid is to be investigated.

**Analysis** The problem is solved using EES, and the solution is given below.

**"Input Data"**

P[1]=100 [kPa]

P[2] = 1000 [kPa]

Fluid\$='R134a'

Eta\_c=0.7 "Compressor isentropic efficiency"

**"Compressor"**

h[1]=enthalpy(Fluid\$,P=P[1],x=1) "properties for state 1"

s[1]=entropy(Fluid\$,P=P[1],x=1)

T[1]=temperature(Fluid\$,h=h[1],P=P[1])

h2s=enthalpy(Fluid\$,P=P[2],s=s[1]) "Identifies state 2s as isentropic"

h[1]+Wcs=h2s "energy balance on isentropic compressor"

W\_c=Wcs/Eta\_c "definition of compressor isentropic efficiency"

h[1]+W\_c=h[2] "energy balance on real compressor-assumed adiabatic"

s[2]=entropy(Fluid\$,h=h[2],P=P[2]) "properties for state 2"

T[2]=temperature(Fluid\$,h=h[2],P=P[2])

**"Condenser"**

P[3] = P[2]

h[3]=enthalpy(Fluid\$,P=P[3],x=0) "properties for state 3"

s[3]=entropy(Fluid\$,P=P[3],x=0)

h[2]=Qout+h[3] "energy balance on condenser"

**"Throttle Valve"**

h[4]=h[3] "energy balance on throttle - isenthalpic"

x[4]=quality(Fluid\$,h=h[4],P=P[4]) "properties for state 4"

s[4]=entropy(Fluid\$,h=h[4],P=P[4])

T[4]=temperature(Fluid\$,h=h[4],P=P[4])

**"Evaporator"**

P[4]= P[1]

Q\_in + h[4]=h[1] "energy balance on evaporator"

"Coefficient of Performance:"

COP=Q\_in/W\_c "definition of COP"

COP	$\eta_c$	P <sub>1</sub> [kPa]
1.851	0.7	100
2.863	0.7	200
4.014	0.7	300
5.462	0.7	400
7.424	0.7	500

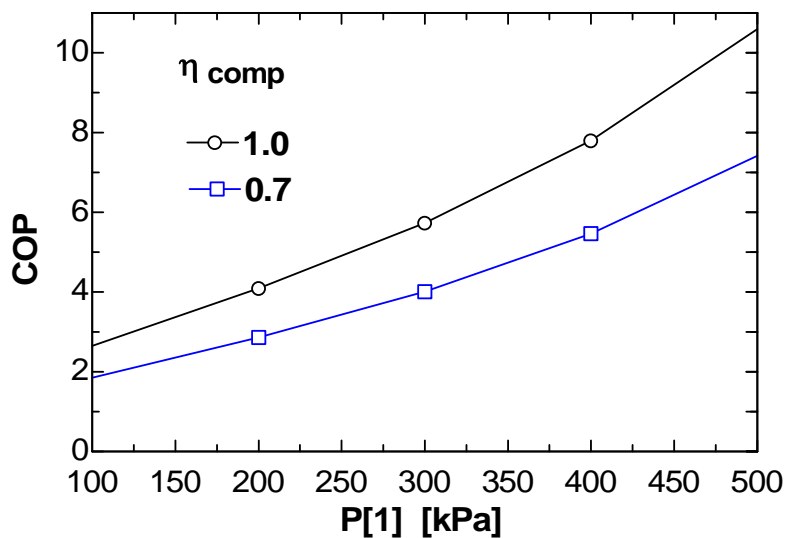

**11-126 EES** The effect of the condenser pressure on the COP of an ideal vapor-compression refrigeration cycle with R-134a as the working fluid is to be investigated.

**Analysis** The problem is solved using EES, and the solution is given below.

"Input Data"

P[1]=120 [kPa]

P[2] = 400 [kPa]

Fluid\$='R134a'

Eta\_c=0.7 "Compressor isentropic efficiency"

"Compressor"

h[1]=enthalpy(Fluid\$,P=P[1],x=1) "properties for state 1"

s[1]=entropy(Fluid\$,P=P[1],x=1)

T[1]=temperature(Fluid\$,h=h[1],P=P[1])

h2s=enthalpy(Fluid\$,P=P[2],s=s[1]) "Identifies state 2s as isentropic"

h[1]+Wcs=h2s "energy balance on isentropic compressor"

W\_c=Wcs/Eta\_c "definition of compressor isentropic efficiency"

h[1]+W\_c=h[2] "energy balance on real compressor-assumed adiabatic"

s[2]=entropy(Fluid\$,h=h[2],P=P[2]) "properties for state 2"

T[2]=temperature(Fluid\$,h=h[2],P=P[2])

"Condenser"

P[3] = P[2]

h[3]=enthalpy(Fluid\$,P=P[3],x=0) "properties for state 3"

s[3]=entropy(Fluid\$,P=P[3],x=0)

h[2]=Qout+h[3] "energy balance on condenser"

"Throttle Valve"

h[4]=h[3] "energy balance on throttle - isenthalpic"

x[4]=quality(Fluid\$,h=h[4],P=P[4]) "properties for state 4"

s[4]=entropy(Fluid\$,h=h[4],P=P[4])

T[4]=temperature(Fluid\$,h=h[4],P=P[4])

"Evaporator"

P[4]= P[1]

Q\_in + h[4]=h[1] "energy balance on evaporator"

"Coefficient of Performance:"

COP=Q\_in/W\_c "definition of COP"

COP	$\eta_c$	$P_2$ [kPa]
4.935	0.7	400
3.04	0.7	650
2.258	0.7	900
1.803	0.7	1150
1.492	0.7	1400

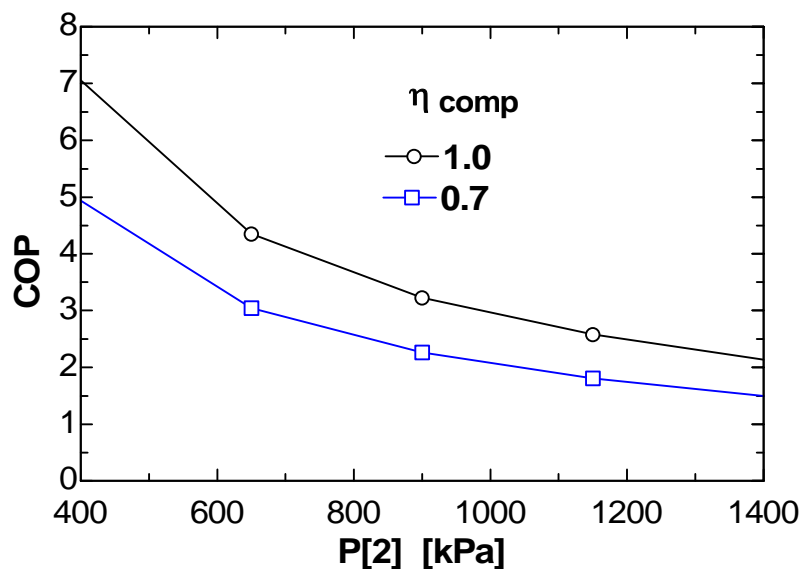

## Fundamentals of Engineering (FE) Exam Problems

**11-127** Consider a heat pump that operates on the reversed Carnot cycle with R-134a as the working fluid executed under the saturation dome between the pressure limits of 140 kPa and 800 kPa. R-134a changes from saturated vapor to saturated liquid during the heat rejection process. The net work input for this cycle is

- (a) 28 kJ/kg      (b) 34 kJ/kg      (c) 49 kJ/kg      (d) 144 kJ/kg      (e) 275 kJ/kg

*Answer* (a) 28 kJ/kg

**Solution** Solved by EES Software. Solutions can be verified by copying-and-pasting the following lines on a blank EES screen. (Similar problems and their solutions can be obtained easily by modifying numerical values).

```
P1=800 "kPa"
P2=140 "kPa"
h_fg=ENTHALPY(R134a,x=1,P=P1)-ENTHALPY(R134a,x=0,P=P1)
TH=TEMPERATURE(R134a,x=0,P=P1)+273
TL=TEMPERATURE(R134a,x=0,P=P2)+273
q_H=h_fg
COP=TH/(TH-TL)
w_net=q_H/COP
```

"Some Wrong Solutions with Common Mistakes:"

W1\_work = q\_H/COP1; COP1=TL/(TH-TL) "Using COP of refrigerator"

W2\_work = q\_H/COP2; COP2=(TH-273)/(TH-TL) "Using C instead of K"

W3\_work = h\_fg3/COP; h\_fg3= ENTHALPY(R134a,x=1,P=P2)-ENTHALPY(R134a,x=0,P=P2)

"Using h\_fg at P2"

W4\_work = q\_H\*TL/TH "Using the wrong relation"

**11-128** A refrigerator removes heat from a refrigerated space at  $-5^{\circ}\text{C}$  at a rate of  $0.35\text{ kJ/s}$  and rejects it to an environment at  $20^{\circ}\text{C}$ . The minimum required power input is

- (a) 30 W                      (b) 33 W                      (c) 56 W                      (d) 124 W                      (e) 350 W

*Answer* (b) 33 W

**Solution** Solved by EES Software. Solutions can be verified by copying-and-pasting the following lines on a blank EES screen. (Similar problems and their solutions can be obtained easily by modifying numerical values).

```
TH=20+273
TL=-5+273
Q_L=0.35 "kJ/s"
COP_max=TL/(TH-TL)
w_min=Q_L/COP_max
```

"Some Wrong Solutions with Common Mistakes:"

```
W1_work = Q_L/COP1; COP1=TH/(TH-TL) "Using COP of heat pump"
W2_work = Q_L/COP2; COP2=(TH-273)/(TH-TL) "Using C instead of K"
W3_work = Q_L*TL/TH "Using the wrong relation"
W4_work = Q_L "Taking the rate of refrigeration as power input"
```

**11-129** A refrigerator operates on the ideal vapor compression refrigeration cycle with R-134a as the working fluid between the pressure limits of 120 kPa and 800 kPa. If the rate of heat removal from the refrigerated space is 32 kJ/s, the mass flow rate of the refrigerant is

- (a) 0.19 kg/s      (b) 0.15 kg/s      (c) 0.23 kg/s      (d) 0.28 kg/s      (e) 0.81 kg/s

*Answer* (c) 0.23 kg/s

**Solution** Solved by EES Software. Solutions can be verified by copying-and-pasting the following lines on a blank EES screen. (Similar problems and their solutions can be obtained easily by modifying numerical values).

```
P1=120 "kPa"
P2=800 "kPa"
P3=P2
P4=P1
s2=s1
Q_refrig=32 "kJ/s"
m=Q_refrig/(h1-h4)
h1=ENTHALPY(R134a,x=1,P=P1)
s1=ENTROPY(R134a,x=1,P=P1)
h2=ENTHALPY(R134a,s=s2,P=P2)
h3=ENTHALPY(R134a,x=0,P=P3)
h4=h3
```

"Some Wrong Solutions with Common Mistakes:"

```
W1_mass = Q_refrig/(h2-h1) "Using wrong enthalpies, for W_in"
W2_mass = Q_refrig/(h2-h3) "Using wrong enthalpies, for Q_H"
W3_mass = Q_refrig/(h1-h44); h44=ENTHALPY(R134a,x=0,P=P4) "Using wrong enthalpy h4 (at P4)"
W4_mass = Q_refrig/h_fg; h_fg=ENTHALPY(R134a,x=1,P=P2) - ENTHALPY(R134a,x=0,P=P2)
"Using h_fg at P2"
```



**11-130** A heat pump operates on the ideal vapor compression refrigeration cycle with R-134a as the working fluid between the pressure limits of 0.32 MPa and 1.2 MPa. If the mass flow rate of the refrigerant is 0.193 kg/s, the rate of heat supply by the heat pump to the heated space is

- (a) 3.3 kW            (b) 23 kW            (c) 26 kW            (d) 31 kW            (e) 45 kW

*Answer* (d) 31 kW

**Solution** Solved by EES Software. Solutions can be verified by copying-and-pasting the following lines on a blank EES screen. (Similar problems and their solutions can be obtained easily by modifying numerical values).

```
P1=320 "kPa"
P2=1200 "kPa"
P3=P2
P4=P1
s2=s1
m=0.193 "kg/s"
Q_supply=m*(h2-h3) "kJ/s"
h1=ENTHALPY(R134a,x=1,P=P1)
s1=ENTROPY(R134a,x=1,P=P1)
h2=ENTHALPY(R134a,s=s2,P=P2)
h3=ENTHALPY(R134a,x=0,P=P3)
h4=h3
```

"Some Wrong Solutions with Common Mistakes:"

```
W1_Qh = m*(h2-h1) "Using wrong enthalpies, for W_in"
W2_Qh = m*(h1-h4) "Using wrong enthalpies, for Q_L"
W3_Qh = m*(h22-h4); h22=ENTHALPY(R134a,x=1,P=P2) "Using wrong enthalpy h2 (hg at P2)"
W4_Qh = m*h_fg; h_fg=ENTHALPY(R134a,x=1,P=P1) - ENTHALPY(R134a,x=0,P=P1) "Using h_fg at P1"
```

**11-131** An ideal vapor compression refrigeration cycle with R-134a as the working fluid operates between the pressure limits of 120 kPa and 1000 kPa. The mass fraction of the refrigerant that is in the liquid phase at the inlet of the evaporator is

- (a) 0.65                      (b) 0.60                      (c) 0.40                      (d) 0.55                      (e) 0.35

*Answer* (b) 0.60

**Solution** Solved by EES Software. Solutions can be verified by copying-and-pasting the following lines on a blank EES screen. (Similar problems and their solutions can be obtained easily by modifying numerical values).

```
P1=120 "kPa"
P2=1000 "kPa"
P3=P2
P4=P1
h1=ENTHALPY(R134a,x=1,P=P1)
h3=ENTHALPY(R134a,x=0,P=P3)
h4=h3
x4=QUALITY(R134a,h=h4,P=P4)
liquid=1-x4
```

"Some Wrong Solutions with Common Mistakes:"

```
W1_liquid = x4 "Taking quality as liquid content"
W2_liquid = 0 "Assuming superheated vapor"
W3_liquid = 1-x4s; x4s=QUALITY(R134a,s=s3,P=P4) "Assuming isentropic expansion"
s3=ENTROPY(R134a,x=0,P=P3)
```

**11-132** Consider a heat pump that operates on the ideal vapor compression refrigeration cycle with R-134a as the working fluid between the pressure limits of 0.32 MPa and 1.2 MPa. The coefficient of performance of this heat pump is

- (a) 0.17                      (b) 1.2                      (c) 3.1                      (d) 4.9                      (e) 5.9

*Answer* (e) 5.9

**Solution** Solved by EES Software. Solutions can be verified by copying-and-pasting the following lines on a blank EES screen. (Similar problems and their solutions can be obtained easily by modifying numerical values).

```
P1=320 "kPa"
P2=1200 "kPa"
P3=P2
P4=P1
s2=s1
h1=ENTHALPY(R134a,x=1,P=P1)
s1=ENTROPY(R134a,x=1,P=P1)
h2=ENTHALPY(R134a,s=s2,P=P2)
h3=ENTHALPY(R134a,x=0,P=P3)
h4=h3
COP_HP=qH/Win
Win=h2-h1
qH=h2-h3
```

"Some Wrong Solutions with Common Mistakes:"

W1\_COP = (h1-h4)/(h2-h1) "COP of refrigerator"

W2\_COP = (h1-h4)/(h2-h3) "Using wrong enthalpies, QL/QH"

W3\_COP = (h22-h3)/(h22-h1); h22=ENTHALPY(R134a,x=1,P=P2) "Using wrong enthalpy h2 (hg at P2)"

**11-133** An ideal gas refrigeration cycle using air as the working fluid operates between the pressure limits of 80 kPa and 280 kPa. Air is cooled to 35°C before entering the turbine. The lowest temperature of this cycle is

- (a) -58°C                      (b) -26°C                      (c) 0°C                      (d) 11°C                      (e) 24°C

*Answer* (a) -58°C

**Solution** Solved by EES Software. Solutions can be verified by copying-and-pasting the following lines on a blank EES screen. (Similar problems and their solutions can be obtained easily by modifying numerical values).

```
k=1.4
P1= 80 "kPa"
P2=280 "kPa"
T3=35+273 "K"
"Minimum temperature is the turbine exit temperature"
T4=T3*(P1/P2)^((k-1)/k) - 273
```

```
"Some Wrong Solutions with Common Mistakes:"
W1_Tmin = (T3-273)*(P1/P2)^((k-1)/k) "Using C instead of K"
W2_Tmin = T3*(P1/P2)^((k-1)) - 273 "Using wrong exponent"
W3_Tmin = T3*(P1/P2)^k - 273 "Using wrong exponent"
```

**11-134** Consider an ideal gas refrigeration cycle using helium as the working fluid. Helium enters the compressor at 100 kPa and  $-10^{\circ}\text{C}$  and is compressed to 250 kPa. Helium is then cooled to  $20^{\circ}\text{C}$  before it enters the turbine. For a mass flow rate of 0.2 kg/s, the net power input required is

- (a) 9.3 kW      (b) 27.6 kW      (c) 48.8 kW      (d) 93.5 kW      (e) 119 kW

*Answer* (b) 27.6 kW

**Solution** Solved by EES Software. Solutions can be verified by copying-and-pasting the following lines on a blank EES screen. (Similar problems and their solutions can be obtained easily by modifying numerical values).

```

k=1.667
Cp=5.1926 "kJ/kg.K"
P1= 100 "kPa"
T1=-10+273 "K"
P2=250 "kPa"
T3=20+273 "K"
m=0.2 "kg/s"
"Minimum temperature is the turbine exit temperature"
T2=T1*(P2/P1)^((k-1)/k)
T4=T3*(P1/P2)^((k-1)/k)
W_netin=m*Cp*((T2-T1)-(T3-T4))

```

"Some Wrong Solutions with Common Mistakes:"

W1\_Win = m\*Cp\*((T2-T1)-(T3-T4)); T2=T1\*P2/P1; T4=T3\*P1/P2 "Using wrong relations for temps"

W2\_Win = m\*Cp\*(T2-T1) "Ignoring turbine work"

W3\_Win=m\*1.005\*((T2-T1)-(T3-T4)); T2=T1\*(P2/P1)^((kB-1)/kB); T4=T3\*(P1/P2)^((kB-1)/kB); kB=1.4 "Using air properties"

W4\_Win=m\*Cp\*((T2-(T1-273))-(T3-273-T4)); T2=(T1-273)\*(P2/P1)^((k-1)/k); T4=(T3-273)\*(P1/P2)^((k-1)/k) "Using C instead of K"

**11-135** An absorption air-conditioning system is to remove heat from the conditioned space at 20°C at a rate of 150 kJ/s while operating in an environment at 35°C. Heat is to be supplied from a geothermal source at 140°C. The minimum rate of heat supply required is

- (a) 86 kJ/s            (b) 21 kJ/s            (c) 30 kJ/s            (d) 61 kJ/s            (e) 150 kJ/s

*Answer* (c) 30 kJ/s

**Solution** Solved by EES Software. Solutions can be verified by copying-and-pasting the following lines on a blank EES screen. (Similar problems and their solutions can be obtained easily by modifying numerical values).

```
TL=20+273 "K"
Q_refrig=150 "kJ/s"
To=35+273 "K"
Ts=140+273 "K"
COP_max=(1-To/Ts)*(TL/(To-TL))
Q_in=Q_refrig/COP_max
```

"Some Wrong Solutions with Common Mistakes:"

```
W1_Qin = Q_refrig "Taking COP = 1"
W2_Qin = Q_refrig/COP2; COP2=TL/(Ts-TL) "Wrong COP expression"
W3_Qin = Q_refrig/COP3; COP3=(1-To/Ts)*(Ts/(To-TL)) "Wrong COP expression, COP_HP"
W4_Qin = Q_refrig*COP_max "Multiplying by COP instead of dividing"
```

**11-136** Consider a refrigerator that operates on the vapor compression refrigeration cycle with R-134a as the working fluid. The refrigerant enters the compressor as saturated vapor at 160 kPa, and exits at 800 kPa and 50°C, and leaves the condenser as saturated liquid at 800 kPa. The coefficient of performance of this refrigerator is

- (a) 2.6                      (b) 1.0                      (c) 4.2                      (d) 3.2                      (e) 4.4

*Answer* (d) 3.2

**Solution** Solved by EES Software. Solutions can be verified by copying-and-pasting the following lines on a blank EES screen. (Similar problems and their solutions can be obtained easily by modifying numerical values).

```
P1=160 "kPa"
P2=800 "kPa"
T2=50 "C"
P3=P2
P4=P1
h1=ENTHALPY(R134a,x=1,P=P1)
s1=ENTROPY(R134a,x=1,P=P1)
h2=ENTHALPY(R134a,T=T2,P=P2)
h3=ENTHALPY(R134a,x=0,P=P3)
h4=h3
COP_R=qL/Win
Win=h2-h1
qL=h1-h4
```

"Some Wrong Solutions with Common Mistakes:"

W1\_COP = (h2-h3)/(h2-h1) "COP of heat pump"

W2\_COP = (h1-h4)/(h2-h3) "Using wrong enthalpies, QL/QH"

W3\_COP = (h1-h4)/(h2s-h1); h2s=ENTHALPY(R134a,s=s1,P=P2) "Assuming isentropic compression"

### 11-137 ... 11-145 Design and Essay Problems

