

YUNUS A. ÇENGEL
MICHAEL A. BOLES

THERMODYNAMICS

An Engineering Approach

**INSTRUCTOR
SOLUTIONS
MANUAL**

Eighth Edition

Solutions Manual for
Thermodynamics: An Engineering Approach
8th Edition
Yunus A. Cengel, Michael A. Boles
McGraw-Hill, 2015

Chapter 1

INTRODUCTION AND BASIC CONCEPTS

PROPRIETARY AND CONFIDENTIAL

This Manual is the proprietary property of McGraw-Hill Education and protected by copyright and other state and federal laws. By opening and using this Manual the user agrees to the following restrictions, and if the recipient does not agree to these restrictions, the Manual should be promptly returned unopened to McGraw-Hill Education: **This Manual is being provided only to authorized professors and instructors for use in preparing for the classes using the affiliated textbook. No other use or distribution of this Manual is permitted. This Manual may not be sold and may not be distributed to or used by any student or other third party. No part of this Manual may be reproduced, displayed or distributed in any form or by any means, electronic or otherwise, without the prior written permission of McGraw-Hill Education.**

Thermodynamics

1-1C Classical thermodynamics is based on experimental observations whereas statistical thermodynamics is based on the average behavior of large groups of particles.

1-2C On a downhill road the potential energy of the bicyclist is being converted to kinetic energy, and thus the bicyclist picks up speed. There is no creation of energy, and thus no violation of the conservation of energy principle.

1-3C A car going uphill without the engine running would increase the energy of the car, and thus it would be a violation of the first law of thermodynamics. Therefore, this cannot happen. Using a level meter (a device with an air bubble between two marks of a horizontal water tube) it can be shown that the road that looks uphill to the eye is actually downhill.

1-4C There is no truth to his claim. It violates the second law of thermodynamics.

Mass, Force, and Units

1-5C Kg-mass is the mass unit in the SI system whereas kg-force is a force unit. 1-kg-force is the force required to accelerate a 1-kg mass by 9.807 m/s^2 . In other words, the weight of 1-kg mass at sea level is 1 kg-force.

1-6C In this unit, the word *light* refers to the speed of light. The light-year unit is then the product of a velocity and time. Hence, this product forms a distance dimension and unit.

1-7C There is no acceleration, thus the net force is zero in both cases.

1-8 The variation of gravitational acceleration above the sea level is given as a function of altitude. The height at which the weight of a body will decrease by 0.3% is to be determined.

Analysis The weight of a body at the elevation z can be expressed as

$$W = mg = m(9.807 - 3.32 \times 10^{-6}z)$$

In our case,

$$W = (1 - 0.3/100)W_s = 0.997W_s = 0.997mg_s = 0.997(m)(9.807)$$

Substituting,

$$0.997(9.807) = (9.807 - 3.32 \times 10^{-6}z) \longrightarrow z = \mathbf{8862 \text{ m}}$$



1-9 The mass of an object is given. Its weight is to be determined.

Analysis Applying Newton's second law, the weight is determined to be

$$W = mg = (200 \text{ kg})(9.6 \text{ m/s}^2) = \mathbf{1920 \text{ N}}$$

1-10 A plastic tank is filled with water. The weight of the combined system is to be determined.

Assumptions The density of water is constant throughout.

Properties The density of water is given to be $\rho = 1000 \text{ kg/m}^3$.

Analysis The mass of the water in the tank and the total mass are

$$m_w = \rho V = (1000 \text{ kg/m}^3)(0.2 \text{ m}^3) = 200 \text{ kg}$$

$$m_{\text{total}} = m_w + m_{\text{tank}} = 200 + 3 = 203 \text{ kg}$$

Thus,

$$W = mg = (203 \text{ kg})(9.81 \text{ m/s}^2) \left(\frac{1 \text{ N}}{1 \text{ kg} \cdot \text{m/s}^2} \right) = \mathbf{1991 \text{ N}}$$

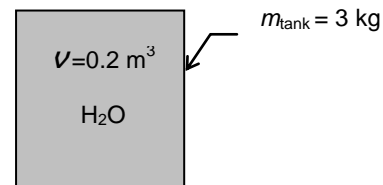

1-11E The constant-pressure specific heat of air given in a specified unit is to be expressed in various units.

Analysis Using proper unit conversions, the constant-pressure specific heat is determined in various units to be

$$c_p = (1.005 \text{ kJ/kg} \cdot ^\circ\text{C}) \left(\frac{1 \text{ kJ/kg} \cdot \text{K}}{1 \text{ kJ/kg} \cdot ^\circ\text{C}} \right) = \mathbf{1.005 \text{ kJ/kg} \cdot \text{K}}$$

$$c_p = (1.005 \text{ kJ/kg} \cdot ^\circ\text{C}) \left(\frac{1000 \text{ J}}{1 \text{ kJ}} \right) \left(\frac{1 \text{ kg}}{1000 \text{ g}} \right) = \mathbf{1.005 \text{ J/g} \cdot ^\circ\text{C}}$$

$$c_p = (1.005 \text{ kJ/kg} \cdot ^\circ\text{C}) \left(\frac{1 \text{ kcal}}{4.1868 \text{ kJ}} \right) = \mathbf{0.240 \text{ kcal/kg} \cdot ^\circ\text{C}}$$

$$c_p = (1.005 \text{ kJ/kg} \cdot ^\circ\text{C}) \left(\frac{1 \text{ Btu/lbm} \cdot ^\circ\text{F}}{4.1868 \text{ kJ/kg} \cdot ^\circ\text{C}} \right) = \mathbf{0.240 \text{ Btu/lbm} \cdot ^\circ\text{F}}$$

1-12  A rock is thrown upward with a specified force. The acceleration of the rock is to be determined.

Analysis The weight of the rock is

$$W = mg = (3 \text{ kg})(9.79 \text{ m/s}^2) \left(\frac{1 \text{ N}}{1 \text{ kg} \cdot \text{m/s}^2} \right) = 29.37 \text{ N}$$

Then the net force that acts on the rock is

$$F_{\text{net}} = F_{\text{up}} - F_{\text{down}} = 200 - 29.37 = 170.6 \text{ N}$$

From the Newton's second law, the acceleration of the rock becomes

$$a = \frac{F}{m} = \frac{170.6 \text{ N}}{3 \text{ kg}} \left(\frac{1 \text{ kg} \cdot \text{m/s}^2}{1 \text{ N}} \right) = \mathbf{56.9 \text{ m/s}^2}$$

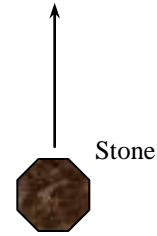



1-13 Problem 1-12 is reconsidered. The entire EES solution is to be printed out, including the numerical results with proper units.

Analysis The problem is solved using EES, and the solution is given below.

"The weight of the rock is"

$$W=m*g$$

$$m=3 \text{ [kg]}$$

$$g=9.79 \text{ [m/s}^2\text{]}$$

"The force balance on the rock yields the net force acting on the rock as"

$$F_{\text{up}}=200 \text{ [N]}$$

$$F_{\text{net}} = F_{\text{up}} - F_{\text{down}}$$

$$F_{\text{down}}=W$$

"The acceleration of the rock is determined from Newton's second law."

$$F_{\text{net}}=m*a$$

"To Run the program, press F2 or select Solve from the Calculate menu."

SOLUTION

$$a=56.88 \text{ [m/s}^2\text{]}$$

$$F_{\text{down}}=29.37 \text{ [N]}$$

$$F_{\text{net}}=170.6 \text{ [N]}$$

$$F_{\text{up}}=200 \text{ [N]}$$

$$g=9.79 \text{ [m/s}^2\text{]}$$

$$m=3 \text{ [kg]}$$

$$W=29.37 \text{ [N]}$$

m [kg]	a [m/s ²]
1	190.2
2	90.21
3	56.88
4	40.21
5	30.21
6	23.54
7	18.78
8	15.21
9	12.43
10	10.21

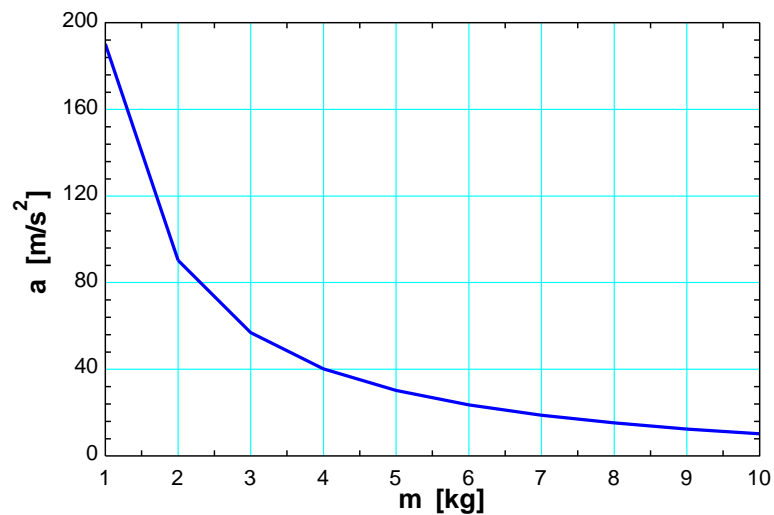

1-14 A resistance heater is used to heat water to desired temperature. The amount of electric energy used in kWh and kJ are to be determined.

Analysis The resistance heater consumes electric energy at a rate of 4 kW or 4 kJ/s. Then the total amount of electric energy used in 3 hours becomes

$$\begin{aligned}\text{Total energy} &= (\text{Energy per unit time})(\text{Time interval}) \\ &= (4 \text{ kW})(3 \text{ h}) \\ &= \mathbf{12 \text{ kWh}}\end{aligned}$$

Noting that 1 kWh = (1 kJ/s)(3600 s) = 3600 kJ,

$$\begin{aligned}\text{Total energy} &= (12 \text{ kWh})(3600 \text{ kJ/kWh}) \\ &= \mathbf{43,200 \text{ kJ}}\end{aligned}$$

Discussion Note kW is a unit for power whereas kWh is a unit for energy.

1-15E An astronaut took his scales with him to space. It is to be determined how much he will weigh on the spring and beam scales in space.

Analysis (a) A spring scale measures weight, which is the local gravitational force applied on a body:

$$W = mg = (150 \text{ lbm})(5.48 \text{ ft/s}^2) \left(\frac{1 \text{ lbf}}{32.2 \text{ lbm} \cdot \text{ft/s}^2} \right) = \mathbf{25.5 \text{ lbf}}$$

(b) A beam scale compares masses and thus is not affected by the variations in gravitational acceleration. The beam scale will read what it reads on earth,

$$W = \mathbf{150 \text{ lbf}}$$

1-16 A gas tank is being filled with gasoline at a specified flow rate. Based on unit considerations alone, a relation is to be obtained for the filling time.

Assumptions Gasoline is an incompressible substance and the flow rate is constant.

Analysis The filling time depends on the volume of the tank and the discharge rate of gasoline. Also, we know that the unit of time is ‘seconds’. Therefore, the independent quantities should be arranged such that we end up with the unit of seconds. Putting the given information into perspective, we have

$$t [\text{s}] \leftrightarrow V [\text{L}], \text{ and } \dot{V} [\text{L/s}]$$

It is obvious that the only way to end up with the unit “s” for time is to divide the tank volume by the discharge rate. Therefore, the desired relation is

$$\boxed{t = \frac{V}{\dot{V}}}$$

Discussion Note that this approach may not work for cases that involve dimensionless (and thus unitless) quantities.

1-17 A pool is to be filled with water using a hose. Based on unit considerations, a relation is to be obtained for the volume of the pool.

Assumptions Water is an incompressible substance and the average flow velocity is constant.

Analysis The pool volume depends on the filling time, the cross-sectional area which depends on hose diameter, and flow velocity. Also, we know that the unit of volume is m^3 . Therefore, the independent quantities should be arranged such that we end up with the unit of seconds. Putting the given information into perspective, we have

$$V [\text{m}^3] \text{ is a function of } t [\text{s}], D [\text{m}], \text{ and } V [\text{m/s}]$$

It is obvious that the only way to end up with the unit “ m^3 ” for volume is to multiply the quantities t and V with the square of D . Therefore, the desired relation is

$$V = CD^2Vt$$

where the constant of proportionality is obtained for a round hose, namely, $C = \pi/4$ so that $V = (\pi D^2/4)Vt$.

Discussion Note that the values of dimensionless constants of proportionality cannot be determined with this approach.

Systems, Properties, State, and Processes

1-18C The radiator should be analyzed as an open system since mass is crossing the boundaries of the system.

1-19C The system is taken as the air contained in the piston-cylinder device. This system is a closed or fixed mass system since no mass enters or leaves it.

1-20C A can of soft drink should be analyzed as a closed system since no mass is crossing the boundaries of the system.

1-21C Intensive properties do not depend on the size (extent) of the system but extensive properties do.

1-22C If we were to divide the system into smaller portions, the weight of each portion would also be smaller. Hence, the weight is an *extensive property*.

1-23C Yes, because temperature and pressure are two independent properties and the air in an isolated room is a simple compressible system.

1-24C If we were to divide this system in half, both the volume and the number of moles contained in each half would be one-half that of the original system. The molar specific volume of the original system is

$$\bar{v} = \frac{V}{N}$$

and the molar specific volume of one of the smaller systems is

$$\bar{v} = \frac{V/2}{N/2} = \frac{V}{N}$$

which is the same as that of the original system. The molar specific volume is then an *intensive property*.

1-25C A process during which a system remains almost in equilibrium at all times is called a quasi-equilibrium process. Many engineering processes can be approximated as being quasi-equilibrium. The work output of a device is maximum and the work input to a device is minimum when quasi-equilibrium processes are used instead of nonquasi-equilibrium processes.

1-26C A process during which the temperature remains constant is called isothermal; a process during which the pressure remains constant is called isobaric; and a process during which the volume remains constant is called isochoric.

1-27C The pressure and temperature of the water are normally used to describe the state. Chemical composition, surface tension coefficient, and other properties may be required in some cases.

As the water cools, its pressure remains fixed. This cooling process is then an isobaric process.

1-28C When analyzing the acceleration of gases as they flow through a nozzle, the proper choice for the system is the volume within the nozzle, bounded by the entire inner surface of the nozzle and the inlet and outlet cross-sections. This is a control volume since mass crosses the boundary.

1-29C The **specific gravity**, or **relative density**, and is defined as the ratio of the density of a substance to the density of some standard substance at a specified temperature (usually water at 4°C, for which $\rho_{\text{H}_2\text{O}} = 1000 \text{ kg/m}^3$). That is, $\text{SG} = \rho / \rho_{\text{H}_2\text{O}}$. When specific gravity is known, density is determined from $\rho = \text{SG} \times \rho_{\text{H}_2\text{O}}$.



1-30 The variation of density of atmospheric air with elevation is given in tabular form. A relation for the variation of density with elevation is to be obtained, the density at 7 km elevation is to be calculated, and the mass of the atmosphere using the correlation is to be estimated.

Assumptions 1 Atmospheric air behaves as an ideal gas. **2** The earth is perfectly sphere with a radius of 6377 km, and the thickness of the atmosphere is 25 km.

Properties The density data are given in tabular form as

r , km	z , km	ρ , kg/m ³
6377	0	1.225
6378	1	1.112
6379	2	1.007
6380	3	0.9093
6381	4	0.8194
6382	5	0.7364
6383	6	0.6601
6385	8	0.5258
6387	10	0.4135
6392	15	0.1948
6397	20	0.08891
6402	25	0.04008

Analysis Using EES, (1) Define a trivial function $\rho = a + bz + cz^2$ in equation window, (2) select new parametric table from Tables, and type the data in a two-column table, (3) select Plot and plot the data, and (4) select plot and click on “curve fit” to get curve fit window. Then specify 2nd order polynomial and enter/edit equation. The results are:

$$\rho(z) = a + bz + cz^2 = 1.20252 - 0.101674z + 0.0022375z^2 \quad \text{for the unit of kg/m}^3,$$

$$\text{(or, } \rho(z) = (1.20252 - 0.101674z + 0.0022375z^2) \times 10^9 \quad \text{for the unit of kg/km}^3)$$

where z is the vertical distance from the earth surface at sea level. At $z = 7$ km, the equation would give $\rho = 0.60$ kg/m³.

(b) The mass of atmosphere can be evaluated by integration to be

$$m = \int_V \rho dV = \int_{z=0}^h (a + bz + cz^2) 4\pi(r_0 + z)^2 dz = 4\pi \int_{z=0}^h (a + bz + cz^2)(r_0^2 + 2r_0z + z^2) dz$$

$$= 4\pi \left[ar_0^2 h + r_0(2a + br_0)h^2 / 2 + (a + 2br_0 + cr_0^2)h^3 / 3 + (b + 2cr_0)h^4 / 4 + ch^5 / 5 \right]$$

where $r_0 = 6377$ km is the radius of the earth, $h = 25$ km is the thickness of the atmosphere, and $a = 1.20252$, $b = -0.101674$, and $c = 0.0022375$ are the constants in the density function. Substituting and multiplying by the factor 10^9 for the density unity kg/km³, the mass of the atmosphere is determined to be

$$m = 5.092 \times 10^{18} \text{ kg}$$

Discussion Performing the analysis with excel would yield exactly the same results.

EES Solution for final result:

$$a=1.2025166; \quad b=-0.10167$$

$$c=0.0022375; \quad r=6377; \quad h=25$$

$$m=4*\pi*(a*r^2*h+r*(2*a+b*r)*h^2/2+(a+2*b*r+c*r^2)*h^3/3+(b+2*c*r)*h^4/4+c*h^5/5)*1E+9$$

Temperature

1-31C They are Celsius ($^{\circ}\text{C}$) and kelvin (K) in the SI, and fahrenheit ($^{\circ}\text{F}$) and rankine (R) in the English system.

1-32C Probably, but not necessarily. The operation of these two thermometers is based on the thermal expansion of a fluid. If the thermal expansion coefficients of both fluids vary linearly with temperature, then both fluids will expand at the same rate with temperature, and both thermometers will always give identical readings. Otherwise, the two readings may deviate.

1-33C Two systems having different temperatures and energy contents are brought in contact. The direction of heat transfer is to be determined.

Analysis Heat transfer occurs from warmer to cooler objects. Therefore, heat will be transferred from system B to system A until both systems reach the same temperature.

1-34 A temperature is given in $^{\circ}\text{C}$. It is to be expressed in K.

Analysis The Kelvin scale is related to Celsius scale by

$$T(\text{K}) = T(^{\circ}\text{C}) + 273$$

Thus,

$$T(\text{K}) = 37^{\circ}\text{C} + 273 = \mathbf{310\text{ K}}$$

1-35E The temperature of air given in $^{\circ}\text{C}$ unit is to be converted to $^{\circ}\text{F}$ and R unit.

Analysis Using the conversion relations between the various temperature scales,

$$T(^{\circ}\text{F}) = 1.8T(^{\circ}\text{C}) + 32 = (1.8)(150) + 32 = \mathbf{302^{\circ}\text{F}}$$

$$T(\text{R}) = T(^{\circ}\text{F}) + 460 = 302 + 460 = \mathbf{762\text{R}}$$

1-36 A temperature change is given in $^{\circ}\text{C}$. It is to be expressed in K.

Analysis This problem deals with temperature changes, which are identical in Kelvin and Celsius scales. Thus,

$$\Delta T(\text{K}) = \Delta T(^{\circ}\text{C}) = \mathbf{70\text{ K}}$$

1-37E The flash point temperature of engine oil given in °F unit is to be converted to K and R units.

Analysis Using the conversion relations between the various temperature scales,

$$T(\text{R}) = T(^{\circ}\text{F}) + 460 = 363 + 460 = \mathbf{823\text{R}}$$

$$T(\text{K}) = \frac{T(\text{R})}{1.8} = \frac{823}{1.8} = \mathbf{457\text{K}}$$

1-38E The temperature of ambient air given in °C unit is to be converted to °F, K and R units.

Analysis Using the conversion relations between the various temperature scales,

$$T = -40^{\circ}\text{C} = (-40)(1.8) + 32 = \mathbf{-40^{\circ}\text{F}}$$

$$T = -40 + 273.15 = \mathbf{233.15\text{K}}$$

$$T = -40 + 459.67 = \mathbf{419.67\text{R}}$$

1-39E A temperature change is given in °F. It is to be expressed in °C, K, and R.

Analysis This problem deals with temperature changes, which are identical in Rankine and Fahrenheit scales. Thus,

$$\Delta T(\text{R}) = \Delta T(^{\circ}\text{F}) = 45 \text{ R}$$

The temperature changes in Celsius and Kelvin scales are also identical, and are related to the changes in Fahrenheit and Rankine scales by

$$\Delta T(\text{K}) = \Delta T(\text{R})/1.8 = 45/1.8 = \mathbf{25 \text{ K}}$$

and $\Delta T(^{\circ}\text{C}) = \Delta T(\text{K}) = \mathbf{25^{\circ}\text{C}}$

Pressure, Manometer, and Barometer

1-40C The atmospheric pressure, which is the external pressure exerted on the skin, decreases with increasing elevation. Therefore, the pressure is lower at higher elevations. As a result, the difference between the blood pressure in the veins and the air pressure outside increases. This pressure imbalance may cause some thin-walled veins such as the ones in the nose to burst, causing bleeding. The shortness of breath is caused by the lower air density at higher elevations, and thus lower amount of oxygen per unit volume.

1-41C The blood vessels are more restricted when the arm is parallel to the body than when the arm is perpendicular to the body. For a constant volume of blood to be discharged by the heart, the blood pressure must increase to overcome the increased resistance to flow.

1-42C No, the absolute pressure in a liquid of constant density does not double when the depth is doubled. It is the *gage pressure* that doubles when the depth is doubled.

1-43C *Pascal's principle* states that *the pressure applied to a confined fluid increases the pressure throughout by the same amount*. This is a consequence of the pressure in a fluid remaining constant in the horizontal direction. An example of Pascal's principle is the operation of the hydraulic car jack.

1-44C The density of air at sea level is higher than the density of air on top of a high mountain. Therefore, the volume flow rates of the two fans running at identical speeds will be the same, but the mass flow rate of the fan at sea level will be higher.

1-45 The pressure in a vacuum chamber is measured by a vacuum gage. The absolute pressure in the chamber is to be determined.

Analysis The absolute pressure in the chamber is determined from

$$P_{\text{abs}} = P_{\text{atm}} - P_{\text{vac}} = 92 - 35 = \mathbf{57 \text{ kPa}}$$

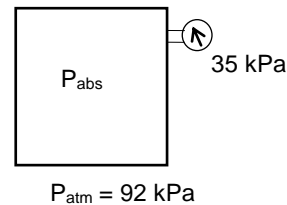

1-46 The pressure in a tank is given. The tank's pressure in various units are to be determined.

Analysis Using appropriate conversion factors, we obtain

$$(a) \quad P = (1200 \text{ kPa}) \left(\frac{1 \text{ kN/m}^2}{1 \text{ kPa}} \right) = \mathbf{1200 \text{ kN/m}^2}$$

$$(b) \quad P = (1200 \text{ kPa}) \left(\frac{1 \text{ kN/m}^2}{1 \text{ kPa}} \right) \left(\frac{1000 \text{ kg} \cdot \text{m/s}^2}{1 \text{ kN}} \right) = \mathbf{1,200,000 \text{ kg/m} \cdot \text{s}^2}$$

$$(c) \quad P = (1200 \text{ kPa}) \left(\frac{1 \text{ kN/m}^2}{1 \text{ kPa}} \right) \left(\frac{1000 \text{ kg} \cdot \text{m/s}^2}{1 \text{ kN}} \right) \left(\frac{1000 \text{ m}}{1 \text{ km}} \right) = \mathbf{1,200,000,000 \text{ kg/km} \cdot \text{s}^2}$$

1-47E The pressure in a tank in SI unit is given. The tank's pressure in various English units are to be determined.

Analysis Using appropriate conversion factors, we obtain

$$(a) \quad P = (1500 \text{ kPa}) \left(\frac{20.886 \text{ lbf/ft}^2}{1 \text{ kPa}} \right) = \mathbf{31,330 \text{ lbf/ft}^2}$$

$$(b) \quad P = (1500 \text{ kPa}) \left(\frac{20.886 \text{ lbf/ft}^2}{1 \text{ kPa}} \right) \left(\frac{1 \text{ ft}^2}{144 \text{ in}^2} \right) \left(\frac{1 \text{ psia}}{1 \text{ lbf/in}^2} \right) = \mathbf{217.6 \text{ psia}}$$

1-48E The pressure given in mm Hg unit is to be converted to psia.

Analysis Using the mm Hg to kPa and kPa to psia units conversion factors,

$$P = (1500 \text{ mm Hg}) \left(\frac{0.1333 \text{ kPa}}{1 \text{ mm Hg}} \right) \left(\frac{1 \text{ psia}}{6.895 \text{ kPa}} \right) = \mathbf{29.0 \text{ psia}}$$

1-49E The pressure in a tank is measured with a manometer by measuring the differential height of the manometer fluid. The absolute pressure in the tank is to be determined for the cases of the manometer arm with the higher and lower fluid level being attached to the tank.

Assumptions The fluid in the manometer is incompressible.

Properties The specific gravity of the fluid is given to be $SG = 1.25$. The density of water at 32°F is 62.4 lbf/ft^3 (Table A-3E)

Analysis The density of the fluid is obtained by multiplying its specific gravity by the density of water,

$$\rho = SG \times \rho_{\text{H}_2\text{O}} = (1.25)(62.4 \text{ lbf/ft}^3) = 78.0 \text{ lbf/ft}^3$$

The pressure difference corresponding to a differential height of 28 in between the two arms of the manometer is

$$\Delta P = \rho g h = (78 \text{ lbf/ft}^3)(32.174 \text{ ft/s}^2)(28/12 \text{ ft}) \left(\frac{1 \text{ lbf}}{32.174 \text{ lbf} \cdot \text{ft/s}^2} \right) \left(\frac{1 \text{ ft}^2}{144 \text{ in}^2} \right) = 1.26 \text{ psia}$$

Then the absolute pressures in the tank for the two cases become:

(a) The fluid level in the arm attached to the tank is higher (vacuum):

$$P_{\text{abs}} = P_{\text{atm}} - P_{\text{vac}} = 12.7 - 1.26 = \mathbf{11.44 \text{ psia}}$$

(b) The fluid level in the arm attached to the tank is lower:

$$P_{\text{abs}} = P_{\text{gage}} + P_{\text{atm}} = 12.7 + 1.26 = \mathbf{13.96 \text{ psia}}$$

Discussion Note that we can determine whether the pressure in a tank is above or below atmospheric pressure by simply observing the side of the manometer arm with the higher fluid level.

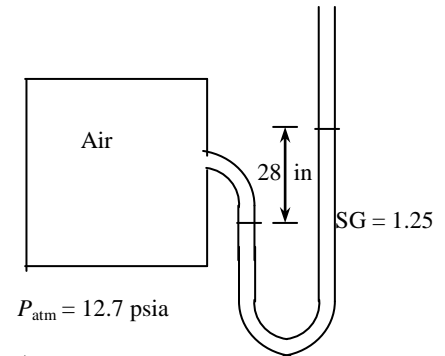

1-50 The pressure in a pressurized water tank is measured by a multi-fluid manometer. The gage pressure of air in the tank is to be determined.

Assumptions The air pressure in the tank is uniform (i.e., its variation with elevation is negligible due to its low density), and thus we can determine the pressure at the air-water interface.

Properties The densities of mercury, water, and oil are given to be 13,600, 1000, and 850 kg/m³, respectively.

Analysis Starting with the pressure at point 1 at the air-water interface, and moving along the tube by adding (as we go down) or subtracting (as we go up) the ρgh terms until we reach point 2, and setting the result equal to P_{atm} since the tube is open to the atmosphere gives

$$P_1 + \rho_{\text{water}} gh_1 + \rho_{\text{oil}} gh_2 - \rho_{\text{mercury}} gh_3 = P_{\text{atm}}$$

Solving for P_1 ,

$$P_1 = P_{\text{atm}} - \rho_{\text{water}} gh_1 - \rho_{\text{oil}} gh_2 + \rho_{\text{mercury}} gh_3$$

or,

$$P_1 - P_{\text{atm}} = g(\rho_{\text{mercury}} h_3 - \rho_{\text{water}} h_1 - \rho_{\text{oil}} h_2)$$

Noting that $P_{1,\text{gage}} = P_1 - P_{\text{atm}}$ and substituting,

$$\begin{aligned} P_{1,\text{gage}} &= (9.81 \text{ m/s}^2)[(13,600 \text{ kg/m}^3)(0.4 \text{ m}) - (1000 \text{ kg/m}^3)(0.2 \text{ m}) \\ &\quad - (850 \text{ kg/m}^3)(0.3 \text{ m})] \left(\frac{1 \text{ N}}{1 \text{ kg} \cdot \text{m/s}^2} \right) \left(\frac{1 \text{ kPa}}{1000 \text{ N/m}^2} \right) \\ &= \mathbf{48.9 \text{ kPa}} \end{aligned}$$

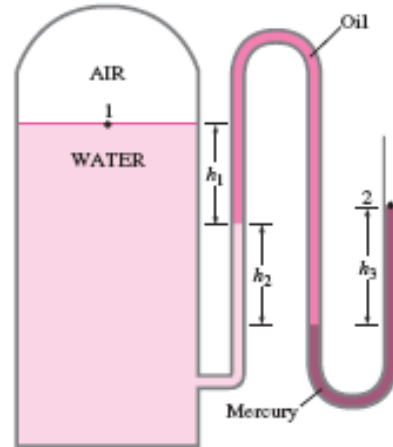

Discussion Note that jumping horizontally from one tube to the next and realizing that pressure remains the same in the same fluid simplifies the analysis greatly.

1-51 The barometric reading at a location is given in height of mercury column. The atmospheric pressure is to be determined.

Properties The density of mercury is given to be 13,600 kg/m³.

Analysis The atmospheric pressure is determined directly from

$$\begin{aligned} P_{\text{atm}} &= \rho gh \\ &= (13,600 \text{ kg/m}^3)(9.81 \text{ m/s}^2)(0.750 \text{ m}) \left(\frac{1 \text{ N}}{1 \text{ kg} \cdot \text{m/s}^2} \right) \left(\frac{1 \text{ kPa}}{1000 \text{ N/m}^2} \right) \\ &= \mathbf{100.1 \text{ kPa}} \end{aligned}$$

1-52E The weight and the foot imprint area of a person are given. The pressures this man exerts on the ground when he stands on one and on both feet are to be determined.

Assumptions The weight of the person is distributed uniformly on foot imprint area.

Analysis The weight of the man is given to be 200 lbf. Noting that pressure is force per unit area, the pressure this man exerts on the ground is

$$(a) \text{ On both feet: } P = \frac{W}{2A} = \frac{200 \text{ lbf}}{2 \times 36 \text{ in}^2} = 2.78 \text{ lbf/in}^2 = \mathbf{2.78 \text{ psi}}$$

$$(b) \text{ On one foot: } P = \frac{W}{A} = \frac{200 \text{ lbf}}{36 \text{ in}^2} = 5.56 \text{ lbf/in}^2 = \mathbf{5.56 \text{ psi}}$$

Discussion Note that the pressure exerted on the ground (and on the feet) is reduced by half when the person stands on both feet.

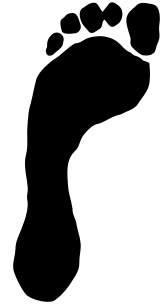

1-53 The gage pressure in a liquid at a certain depth is given. The gage pressure in the same liquid at a different depth is to be determined.

Assumptions The variation of the density of the liquid with depth is negligible.

Analysis The gage pressure at two different depths of a liquid can be expressed as

$$P_1 = \rho g h_1 \quad \text{and} \quad P_2 = \rho g h_2$$

Taking their ratio,

$$\frac{P_2}{P_1} = \frac{\rho g h_2}{\rho g h_1} = \frac{h_2}{h_1}$$

Solving for P_2 and substituting gives

$$P_2 = \frac{h_2}{h_1} P_1 = \frac{9 \text{ m}}{3 \text{ m}} (42 \text{ kPa}) = \mathbf{126 \text{ kPa}}$$

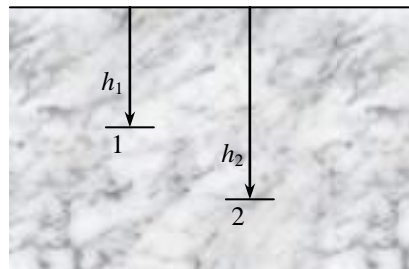

Discussion Note that the gage pressure in a given fluid is proportional to depth.

1-54 The absolute pressure in water at a specified depth is given. The local atmospheric pressure and the absolute pressure at the same depth in a different liquid are to be determined.

Assumptions The liquid and water are incompressible.

Properties The specific gravity of the fluid is given to be $SG = 0.85$. We take the density of water to be 1000 kg/m^3 . Then density of the liquid is obtained by multiplying its specific gravity by the density of water,

$$\rho = SG \times \rho_{H_2O} = (0.85)(1000 \text{ kg/m}^3) = 850 \text{ kg/m}^3$$

Analysis (a) Knowing the absolute pressure, the atmospheric pressure can be determined from

$$\begin{aligned} P_{\text{atm}} &= P - \rho gh \\ &= (185 \text{ kPa}) - (1000 \text{ kg/m}^3)(9.81 \text{ m/s}^2)(9 \text{ m}) \left(\frac{1 \text{ kPa}}{1000 \text{ N/m}^2} \right) \\ &= \mathbf{96.7 \text{ kPa}} \end{aligned}$$

(b) The absolute pressure at a depth of 5 m in the other liquid is

$$\begin{aligned} P &= P_{\text{atm}} + \rho gh \\ &= (96.7 \text{ kPa}) + (850 \text{ kg/m}^3)(9.81 \text{ m/s}^2)(9 \text{ m}) \left(\frac{1 \text{ kPa}}{1000 \text{ N/m}^2} \right) \\ &= \mathbf{171.8 \text{ kPa}} \end{aligned}$$

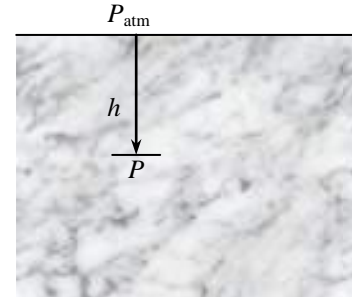

Discussion Note that at a given depth, the pressure in the lighter fluid is lower, as expected.

1-55E A submarine is cruising at a specified depth from the water surface. The pressure exerted on the surface of the submarine by water is to be determined.

Assumptions The variation of the density of water with depth is negligible.

Properties The specific gravity of seawater is given to be $SG = 1.03$. The density of water at 32°F is 62.4 lbm/ft^3 (Table A-3E).

Analysis The density of the seawater is obtained by multiplying its specific gravity by the density of water,

$$\rho = SG \times \rho_{H_2O} = (1.03)(62.4 \text{ lbm/ft}^3) = 64.27 \text{ lbm/ft}^3$$

The pressure exerted on the surface of the submarine cruising 300 ft below the free surface of the sea is the absolute pressure at that location:

$$\begin{aligned} P &= P_{\text{atm}} + \rho gh \\ &= (14.7 \text{ psia}) + (64.27 \text{ lbm/ft}^3)(32.2 \text{ ft/s}^2)(175 \text{ ft}) \left(\frac{1 \text{ lbf}}{32.2 \text{ lbm} \cdot \text{ft/s}^2} \right) \left(\frac{1 \text{ ft}^2}{144 \text{ in}^2} \right) \\ &= \mathbf{92.8 \text{ psia}} \end{aligned}$$

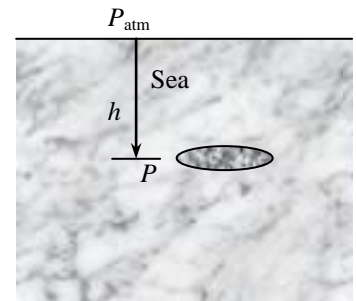

1-56 The mass of a woman is given. The minimum imprint area per shoe needed to enable her to walk on the snow without sinking is to be determined.

Assumptions 1 The weight of the person is distributed uniformly on the imprint area of the shoes. **2** One foot carries the entire weight of a person during walking, and the shoe is sized for walking conditions (rather than standing). **3** The weight of the shoes is negligible.

Analysis The mass of the woman is given to be 70 kg. For a pressure of 0.5 kPa on the snow, the imprint area of one shoe must be

$$A = \frac{W}{P} = \frac{mg}{P}$$

$$= \frac{(70 \text{ kg})(9.81 \text{ m/s}^2)}{0.5 \text{ kPa}} \left(\frac{1 \text{ N}}{1 \text{ kg} \cdot \text{m/s}^2} \right) \left(\frac{1 \text{ kPa}}{1000 \text{ N/m}^2} \right) = \mathbf{1.37 \text{ m}^2}$$

Discussion This is a very large area for a shoe, and such shoes would be impractical to use. Therefore, some sinking of the snow should be allowed to have shoes of reasonable size.



1-57E The vacuum pressure given in kPa unit is to be converted to various units.

Analysis Using the definition of vacuum pressure,

$$P_{\text{gage}} = \text{not applicable for pressures below atmospheric pressure}$$

$$P_{\text{abs}} = P_{\text{atm}} - P_{\text{vac}} = 98 - 80 = \mathbf{18 \text{ kPa}}$$

Then using the conversion factors,

$$P_{\text{abs}} = (18 \text{ kPa}) \left(\frac{1 \text{ kN/m}^2}{1 \text{ kPa}} \right) = \mathbf{18 \text{ kN/m}^2}$$

$$P_{\text{abs}} = (18 \text{ kPa}) \left(\frac{1 \text{ lbf/in}^2}{6.895 \text{ kPa}} \right) = \mathbf{2.61 \text{ lbf/in}^2}$$

$$P_{\text{abs}} = (18 \text{ kPa}) \left(\frac{1 \text{ psi}}{6.895 \text{ kPa}} \right) = \mathbf{2.61 \text{ psi}}$$

$$P_{\text{abs}} = (18 \text{ kPa}) \left(\frac{1 \text{ mm Hg}}{0.1333 \text{ kPa}} \right) = \mathbf{135 \text{ mm Hg}}$$

1-58 A mountain hiker records the barometric reading before and after a hiking trip. The vertical distance climbed is to be determined.

Assumptions The variation of air density and the gravitational acceleration with altitude is negligible.

Properties The density of air is given to be $\rho = 1.20 \text{ kg/m}^3$.

Analysis Taking an air column between the top and the bottom of the mountain and writing a force balance per unit base area, we obtain

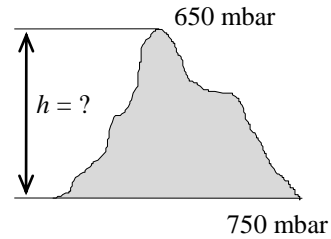

$$W_{\text{air}} / A = P_{\text{bottom}} - P_{\text{top}}$$

$$(\rho gh)_{\text{air}} = P_{\text{bottom}} - P_{\text{top}}$$

$$(1.20 \text{ kg/m}^3)(9.81 \text{ m/s}^2)(h) \left(\frac{1 \text{ N}}{1 \text{ kg} \cdot \text{m/s}^2} \right) \left(\frac{1 \text{ bar}}{100,000 \text{ N/m}^2} \right) = (0.750 - 0.650) \text{ bar}$$

It yields

$$h = \mathbf{850 \text{ m}}$$

which is also the distance climbed.

1-59 A barometer is used to measure the height of a building by recording reading at the bottom and at the top of the building. The height of the building is to be determined.

Assumptions The variation of air density with altitude is negligible.

Properties The density of air is given to be $\rho = 1.18 \text{ kg/m}^3$. The density of mercury is $13,600 \text{ kg/m}^3$.

Analysis Atmospheric pressures at the top and at the bottom of the building are

$$\begin{aligned} P_{\text{top}} &= (\rho gh)_{\text{top}} \\ &= (13,600 \text{ kg/m}^3)(9.81 \text{ m/s}^2)(0.675 \text{ m}) \left(\frac{1 \text{ N}}{1 \text{ kg} \cdot \text{m/s}^2} \right) \left(\frac{1 \text{ kPa}}{1000 \text{ N/m}^2} \right) \\ &= 90.06 \text{ kPa} \end{aligned}$$

$$\begin{aligned} P_{\text{bottom}} &= (\rho gh)_{\text{bottom}} \\ &= (13,600 \text{ kg/m}^3)(9.81 \text{ m/s}^2)(0.695 \text{ m}) \left(\frac{1 \text{ N}}{1 \text{ kg} \cdot \text{m/s}^2} \right) \left(\frac{1 \text{ kPa}}{1000 \text{ N/m}^2} \right) \\ &= 92.72 \text{ kPa} \end{aligned}$$

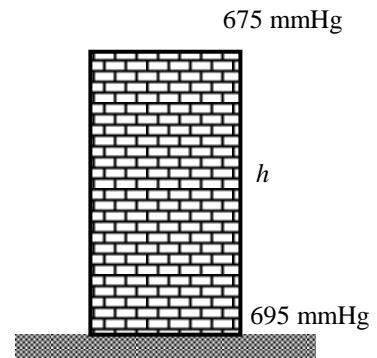

Taking an air column between the top and the bottom of the building and writing a force balance per unit base area, we obtain

$$W_{\text{air}} / A = P_{\text{bottom}} - P_{\text{top}}$$

$$(\rho gh)_{\text{air}} = P_{\text{bottom}} - P_{\text{top}}$$

$$(1.18 \text{ kg/m}^3)(9.81 \text{ m/s}^2)(h) \left(\frac{1 \text{ N}}{1 \text{ kg} \cdot \text{m/s}^2} \right) \left(\frac{1 \text{ kPa}}{1000 \text{ N/m}^2} \right) = (92.72 - 90.06) \text{ kPa}$$

It yields

$$h = \mathbf{231 \text{ m}}$$

which is also the height of the building.



1-60 Problem 1-59 is reconsidered. The entire EES solution is to be printed out, including the numerical results with proper units.

Analysis The problem is solved using EES, and the solution is given below.

```
P_bottom=695 [mmHg]
P_top=675 [mmHg]
g=9.81 [m/s^2] "local acceleration of gravity at sea level"
rho=1.18 [kg/m^3]
DELTAP_abs=(P_bottom-P_top)*CONVERT(mmHg, kPa) "[kPa]" "Delta P reading from the barometers,
converted from mmHg to kPa."
DELTAP_h =rho*g*h*Convert(Pa, kPa) "Delta P due to the air fluid column height, h, between the top and bottom
of the building."
DELTAP_abs=DELTAP_h
```

SOLUTION

```
DELTAP_abs=2.666 [kPa]
DELTAP_h=2.666 [kPa]
g=9.81 [m/s^2]
h=230.3 [m]
P_bottom=695 [mmHg]
P_top=675 [mmHg]
rho=1.18 [kg/m^3]
```

1-61 The hydraulic lift in a car repair shop is to lift cars. The fluid gage pressure that must be maintained in the reservoir is to be determined.

Assumptions The weight of the piston of the lift is negligible.

Analysis Pressure is force per unit area, and thus the gage pressure required is simply the ratio of the weight of the car to the area of the lift,

$$P_{\text{gage}} = \frac{W}{A} = \frac{mg}{\pi D^2 / 4}$$

$$= \frac{(2000 \text{ kg})(9.81 \text{ m/s}^2)}{\pi(0.30 \text{ m})^2 / 4} \left(\frac{1 \text{ kN}}{1000 \text{ kg} \cdot \text{m/s}^2} \right) = 278 \text{ kN/m}^2 = \mathbf{278 \text{ kPa}}$$

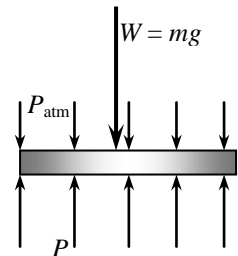

Discussion Note that the pressure level in the reservoir can be reduced by using a piston with a larger area.

1-62 A gas contained in a vertical piston-cylinder device is pressurized by a spring and by the weight of the piston. The pressure of the gas is to be determined.

Analysis Drawing the free body diagram of the piston and balancing the vertical forces yield

$$PA = P_{\text{atm}}A + W + F_{\text{spring}}$$

Thus,

$$\begin{aligned} P &= P_{\text{atm}} + \frac{mg + F_{\text{spring}}}{A} \\ &= (95 \text{ kPa}) + \frac{(3.2 \text{ kg})(9.81 \text{ m/s}^2) + 150 \text{ N}}{35 \times 10^{-4} \text{ m}^2} \left(\frac{1 \text{ kPa}}{1000 \text{ N/m}^2} \right) \\ &= \mathbf{147 \text{ kPa}} \end{aligned}$$

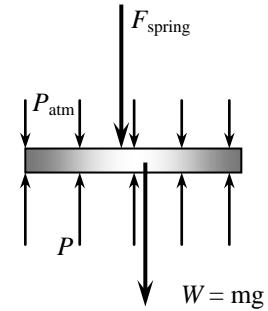

1-63 Problem 1-62 is reconsidered. The effect of the spring force in the range of 0 to 500 N on the pressure inside the cylinder is to be investigated. The pressure against the spring force is to be plotted, and results are to be discussed.

Analysis The problem is solved using EES, and the solution is given below.

```
g=9.81 [m/s^2]
P_atm= 95 [kPa]
m_piston=3.2 [kg]
{F_spring=150 [N]}
A=35*CONVERT(cm^2, m^2)
W_piston=m_piston*g
F_atm=P_atm*A*CONVERT(kPa, N/m^2)
"From the free body diagram of the piston, the balancing vertical forces yield:"
F_gas= F_atm+F_spring+W_piston
P_gas=F_gas/A*CONVERT(N/m^2, kPa)
```

F_{spring} [N]	P_{gas} [kPa]
0	104
50	118.3
100	132.5
150	146.8
200	161.1
250	175.4
300	189.7
350	204
400	218.3
450	232.5
500	246.8

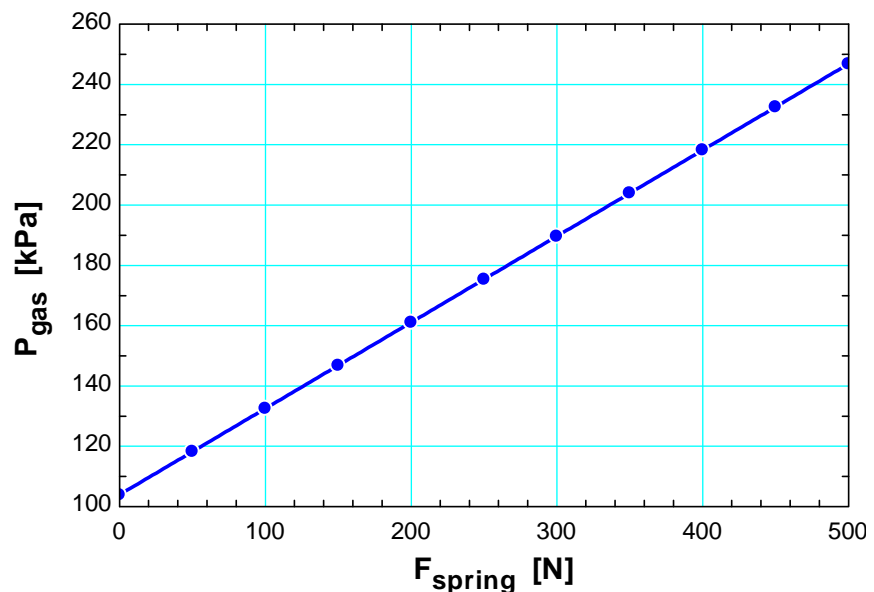



1-64 Both a gage and a manometer are attached to a gas to measure its pressure. For a specified reading of gage pressure, the difference between the fluid levels of the two arms of the manometer is to be determined for mercury and water.

Properties The densities of water and mercury are given to be $\rho_{\text{water}} = 1000 \text{ kg/m}^3$ and be $\rho_{\text{Hg}} = 13,600 \text{ kg/m}^3$.

Analysis The gage pressure is related to the vertical distance h between the two fluid levels by

$$P_{\text{gage}} = \rho g h \longrightarrow h = \frac{P_{\text{gage}}}{\rho g}$$

(a) For mercury,

$$\begin{aligned} h &= \frac{P_{\text{gage}}}{\rho_{\text{Hg}} g} \\ &= \frac{80 \text{ kPa}}{(13,600 \text{ kg/m}^3)(9.81 \text{ m/s}^2)} \left(\frac{1 \text{ kN/m}^2}{1 \text{ kPa}} \right) \left(\frac{1000 \text{ kg/m} \cdot \text{s}^2}{1 \text{ kN}} \right) = \mathbf{0.60 \text{ m}} \end{aligned}$$

(b) For water,

$$h = \frac{P_{\text{gage}}}{\rho_{\text{H}_2\text{O}} g} = \frac{80 \text{ kPa}}{(1000 \text{ kg/m}^3)(9.81 \text{ m/s}^2)} \left(\frac{1 \text{ kN/m}^2}{1 \text{ kPa}} \right) \left(\frac{1000 \text{ kg/m} \cdot \text{s}^2}{1 \text{ kN}} \right) = \mathbf{8.16 \text{ m}}$$

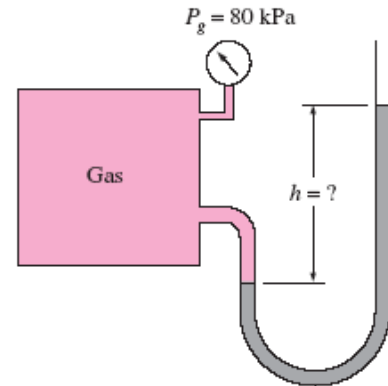



1-65 Problem 1-64 is reconsidered. The effect of the manometer fluid density in the range of 800 to 13,000 kg/m³ on the differential fluid height of the manometer is to be investigated. Differential fluid height against the density is to be plotted, and the results are to be discussed.

Analysis The problem is solved using EES, and the solution is given below.

"Let's modify this problem to also calculate the absolute pressure in the tank by supplying the atmospheric pressure.

Use the relationship between the pressure gage reading and the manometer fluid column height. "

Function fluid_density(Fluid\$)

"This function is needed since if-then-else logic can only be used in functions or procedures.

The underscore displays whatever follows as subscripts in the Formatted Equations Window."

If fluid\$='Mercury' then fluid_density=13600 else fluid_density=1000

end

{Input from the diagram window. If the diagram window is hidden, then all of the input must come from the equations window. Also note that brackets can also denote comments - but these comments do not appear in the formatted equations window.}

{Fluid\$='Mercury'

P_atm = 101.325 [kPa]

DELTAP=80 [kPa] "Note how DELTAP is displayed on the Formatted Equations Window."}

g=9.807 [m/s^2] "local acceleration of gravity at sea level"

rho=fluid_density(Fluid\$) "Get the fluid density, either Hg or H2O, from the function"

"To plot fluid height against density place {} around the above equation. Then set up the parametric table and solve."

DELTAP = RHO*g*h/1000

"Instead of dividing by 1000 Pa/kPa we could have multiplied by the EES function, CONVERT(Pa,kPa)"

h_mm=h*convert(m, mm) "The fluid height in mm is found using the built-in CONVERT function."

P_abs= P_atm + DELTAP

"To make the graph, hide the diagram window and remove the {}brackets from Fluid\$ and from P_atm. Select New Parametric Table from the Tables menu. Choose P_abs, DELTAP and h to be in the table. Choose Alter Values from the Tables menu. Set values of h to range from 0 to 1 in steps of 0.2. Choose Solve Table (or press F3) from the Calculate menu. Choose New Plot Window from the Plot menu. Choose to plot P_abs vs h and then choose Overlay Plot from the Plot menu and plot DELTAP on the same scale."

Manometer Fluid Height vs Manometer Fluid Density

ρ [kg/m ³]	h_{mm} [mm]
800	10197
2156	3784
3511	2323
4867	1676
6222	1311
7578	1076
8933	913.1
10289	792.8
11644	700.5
13000	627.5

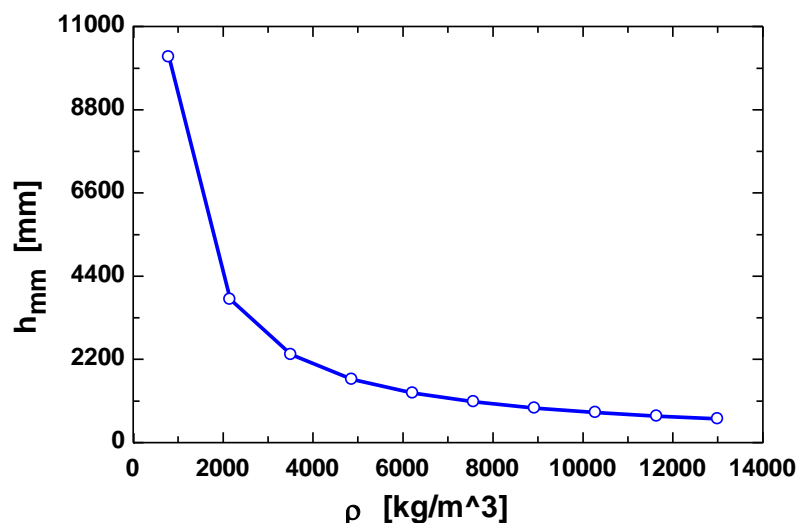

1-66 The air pressure in a tank is measured by an oil manometer. For a given oil-level difference between the two columns, the absolute pressure in the tank is to be determined.

Properties The density of oil is given to be $\rho = 850 \text{ kg/m}^3$.

Analysis The absolute pressure in the tank is determined from

$$\begin{aligned} P &= P_{\text{atm}} + \rho gh \\ &= (98 \text{ kPa}) + (850 \text{ kg/m}^3)(9.81 \text{ m/s}^2)(0.80 \text{ m}) \left(\frac{1 \text{ kPa}}{1000 \text{ N/m}^2} \right) \\ &= \mathbf{104.7 \text{ kPa}} \end{aligned}$$

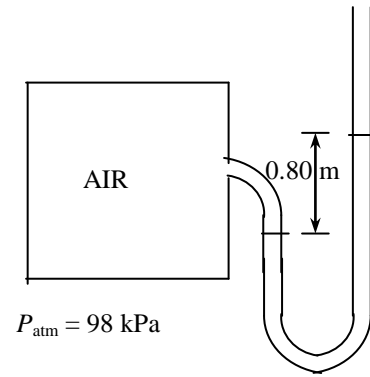

1-67 The air pressure in a duct is measured by a mercury manometer. For a given mercury-level difference between the two columns, the absolute pressure in the duct is to be determined.

Properties The density of mercury is given to be $\rho = 13,600 \text{ kg/m}^3$.

Analysis (a) The pressure in the duct is above atmospheric pressure since the fluid column on the duct side is at a lower level.

(b) The absolute pressure in the duct is determined from

$$\begin{aligned} P &= P_{\text{atm}} + \rho gh \\ &= (100 \text{ kPa}) + (13,600 \text{ kg/m}^3)(9.81 \text{ m/s}^2)(0.015 \text{ m}) \left(\frac{1 \text{ N}}{1 \text{ kg} \cdot \text{m/s}^2} \right) \left(\frac{1 \text{ kPa}}{1000 \text{ N/m}^2} \right) \\ &= \mathbf{102 \text{ kPa}} \end{aligned}$$

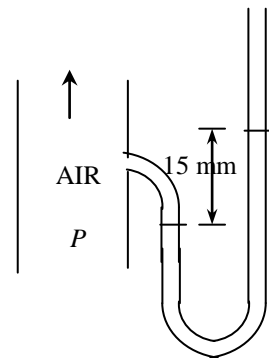

1-68 The air pressure in a duct is measured by a mercury manometer. For a given mercury-level difference between the two columns, the absolute pressure in the duct is to be determined.

Properties The density of mercury is given to be $\rho = 13,600 \text{ kg/m}^3$.

Analysis (a) The pressure in the duct is above atmospheric pressure since the fluid column on the duct side is at a lower level.

(b) The absolute pressure in the duct is determined from

$$\begin{aligned} P &= P_{\text{atm}} + \rho gh \\ &= (100 \text{ kPa}) + (13,600 \text{ kg/m}^3)(9.81 \text{ m/s}^2)(0.045 \text{ m}) \left(\frac{1 \text{ N}}{1 \text{ kg} \cdot \text{m/s}^2} \right) \left(\frac{1 \text{ kPa}}{1000 \text{ N/m}^2} \right) \\ &= \mathbf{106 \text{ kPa}} \end{aligned}$$

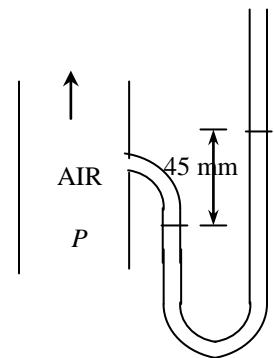

1-69E The pressure in a natural gas pipeline is measured by a double U-tube manometer with one of the arms open to the atmosphere. The absolute pressure in the pipeline is to be determined.

Assumptions **1** All the liquids are incompressible. **2** The effect of air column on pressure is negligible. **3** The pressure throughout the natural gas (including the tube) is uniform since its density is low.

Properties We take the density of water to be $\rho_w = 62.4 \text{ lbm/ft}^3$. The specific gravity of mercury is given to be 13.6, and thus its density is $\rho_{\text{Hg}} = 13.6 \times 62.4 = 848.6 \text{ lbm/ft}^3$.

Analysis Starting with the pressure at point 1 in the natural gas pipeline, and moving along the tube by adding (as we go down) or subtracting (as we go up) the ρgh terms until we reach the free surface of oil where the oil tube is exposed to the atmosphere, and setting the result equal to P_{atm} gives

$$P_1 - \rho_{\text{Hg}} g h_{\text{Hg}} - \rho_{\text{water}} g h_{\text{water}} = P_{\text{atm}}$$

Solving for P_1 ,

$$P_1 = P_{\text{atm}} + \rho_{\text{Hg}} g h_{\text{Hg}} + \rho_{\text{water}} g h_1$$

Substituting,

$$P = 14.2 \text{ psia} + (32.2 \text{ ft/s}^2)[(848.6 \text{ lbm/ft}^3)(6/12 \text{ ft}) + (62.4 \text{ lbm/ft}^3)(27/12 \text{ ft})] \left(\frac{1 \text{ lbf}}{32.2 \text{ lbm} \cdot \text{ft/s}^2} \right) \left(\frac{1 \text{ ft}^2}{144 \text{ in}^2} \right) \\ = \mathbf{18.1 \text{ psia}}$$

Discussion Note that jumping horizontally from one tube to the next and realizing that pressure remains the same in the same fluid simplifies the analysis greatly. Also, it can be shown that the 15-in high air column with a density of 0.075 lbm/ft^3 corresponds to a pressure difference of 0.00065 psi . Therefore, its effect on the pressure difference between the two pipes is negligible.

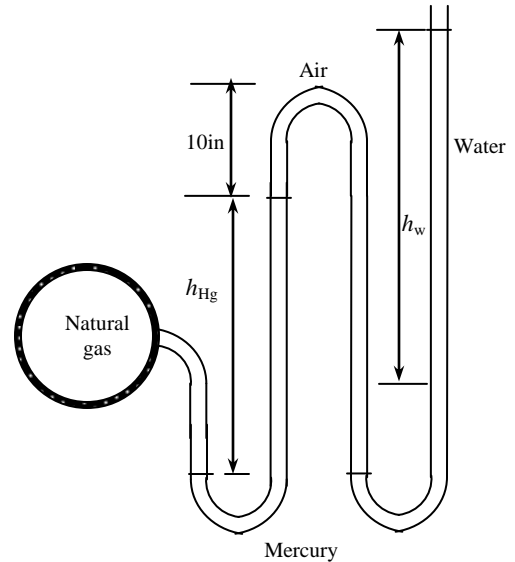

1-70E The pressure in a natural gas pipeline is measured by a double U-tube manometer with one of the arms open to the atmosphere. The absolute pressure in the pipeline is to be determined.

Assumptions 1 All the liquids are incompressible. **2** The pressure throughout the natural gas (including the tube) is uniform since its density is low.

Properties We take the density of water to be $\rho_w = 62.4 \text{ lbm/ft}^3$. The specific gravity of mercury is given to be 13.6, and thus its density is $\rho_{\text{Hg}} = 13.6 \times 62.4 = 848.6 \text{ lbm/ft}^3$. The specific gravity of oil is given to be 0.69, and thus its density is $\rho_{\text{oil}} = 0.69 \times 62.4 = 43.1 \text{ lbm/ft}^3$.

Analysis Starting with the pressure at point 1 in the natural gas pipeline, and moving along the tube by adding (as we go down) or subtracting (as we go up) the ρgh terms until we reach the free surface of oil where the oil tube is exposed to the atmosphere, and setting the result equal to P_{atm} gives

$$P_1 - \rho_{\text{Hg}} gh_{\text{Hg}} + \rho_{\text{oil}} gh_{\text{oil}} - \rho_{\text{water}} gh_{\text{water}} = P_{\text{atm}}$$

Solving for P_1 ,

$$P_1 = P_{\text{atm}} + \rho_{\text{Hg}} gh_{\text{Hg}} + \rho_{\text{water}} gh_1 - \rho_{\text{oil}} gh_{\text{oil}}$$

Substituting,

$$\begin{aligned} P_1 &= 14.2 \text{ psia} + (32.2 \text{ ft/s}^2)[(848.6 \text{ lbm/ft}^3)(6/12 \text{ ft}) + (62.4 \text{ lbm/ft}^3)(27/12 \text{ ft}) \\ &\quad - (43.1 \text{ lbm/ft}^3)(15/12 \text{ ft})] \left(\frac{1 \text{ lbf}}{32.2 \text{ lbm} \cdot \text{ft/s}^2} \right) \left(\frac{1 \text{ ft}^2}{144 \text{ in}^2} \right) \\ &= \mathbf{17.7 \text{ psia}} \end{aligned}$$

Discussion Note that jumping horizontally from one tube to the next and realizing that pressure remains the same in the same fluid simplifies the analysis greatly.

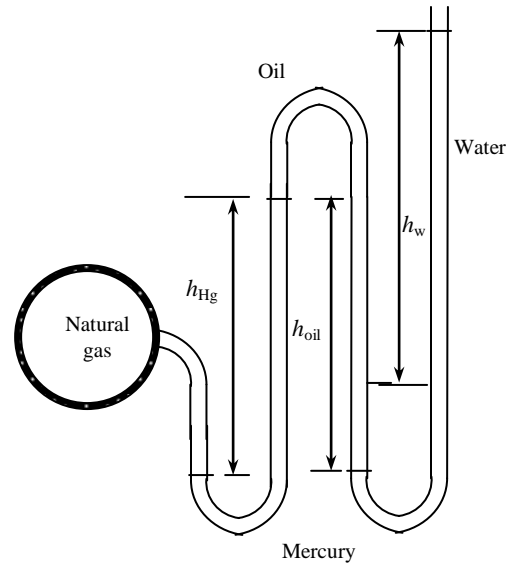

1-71E The systolic and diastolic pressures of a healthy person are given in mmHg. These pressures are to be expressed in kPa, psi, and meter water column.

Assumptions Both mercury and water are incompressible substances.

Properties We take the densities of water and mercury to be 1000 kg/m^3 and $13,600 \text{ kg/m}^3$, respectively.

Analysis Using the relation $P = \rho gh$ for gage pressure, the high and low pressures are expressed as

$$P_{\text{high}} = \rho gh_{\text{high}} = (13,600 \text{ kg/m}^3)(9.81 \text{ m/s}^2)(0.12 \text{ m}) \left(\frac{1 \text{ N}}{1 \text{ kg} \cdot \text{m/s}^2} \right) \left(\frac{1 \text{ kPa}}{1000 \text{ N/m}^2} \right) = \mathbf{16.0 \text{ kPa}}$$

$$P_{\text{low}} = \rho gh_{\text{low}} = (13,600 \text{ kg/m}^3)(9.81 \text{ m/s}^2)(0.08 \text{ m}) \left(\frac{1 \text{ N}}{1 \text{ kg} \cdot \text{m/s}^2} \right) \left(\frac{1 \text{ kPa}}{1000 \text{ N/m}^2} \right) = \mathbf{10.7 \text{ kPa}}$$

Noting that $1 \text{ psi} = 6.895 \text{ kPa}$,

$$P_{\text{high}} = (16.0 \text{ Pa}) \left(\frac{1 \text{ psi}}{6.895 \text{ kPa}} \right) = \mathbf{2.32 \text{ psi}} \quad \text{and} \quad P_{\text{low}} = (10.7 \text{ Pa}) \left(\frac{1 \text{ psi}}{6.895 \text{ kPa}} \right) = \mathbf{1.55 \text{ psi}}$$

For a given pressure, the relation $P = \rho gh$ can be expressed for mercury and water as $P = \rho_{\text{water}} gh_{\text{water}}$ and $P = \rho_{\text{mercury}} gh_{\text{mercury}}$. Setting these two relations equal to each other and solving for water height gives

$$P = \rho_{\text{water}} gh_{\text{water}} = \rho_{\text{mercury}} gh_{\text{mercury}} \rightarrow h_{\text{water}} = \frac{\rho_{\text{mercury}}}{\rho_{\text{water}}} h_{\text{mercury}}$$

Therefore,

$$h_{\text{water, high}} = \frac{\rho_{\text{mercury}}}{\rho_{\text{water}}} h_{\text{mercury, high}} = \frac{13,600 \text{ kg/m}^3}{1000 \text{ kg/m}^3} (0.12 \text{ m}) = \mathbf{1.63 \text{ m}}$$

$$h_{\text{water, low}} = \frac{\rho_{\text{mercury}}}{\rho_{\text{water}}} h_{\text{mercury, low}} = \frac{13,600 \text{ kg/m}^3}{1000 \text{ kg/m}^3} (0.08 \text{ m}) = \mathbf{1.09 \text{ m}}$$

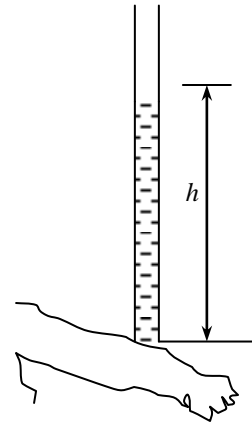

Discussion Note that measuring blood pressure with a “water” monometer would involve differential fluid heights higher than the person, and thus it is impractical. This problem shows why mercury is a suitable fluid for blood pressure measurement devices.

1-72 A vertical tube open to the atmosphere is connected to the vein in the arm of a person. The height that the blood will rise in the tube is to be determined.

Assumptions 1 The density of blood is constant. 2 The gage pressure of blood is 120 mmHg.

Properties The density of blood is given to be $\rho = 1050 \text{ kg/m}^3$.

Analysis For a given gage pressure, the relation $P = \rho gh$ can be expressed

for mercury and blood as $P = \rho_{\text{blood}} g h_{\text{blood}}$ and $P = \rho_{\text{mercury}} g h_{\text{mercury}}$.

Setting these two relations equal to each other we get

$$P = \rho_{\text{blood}} g h_{\text{blood}} = \rho_{\text{mercury}} g h_{\text{mercury}}$$

Solving for blood height and substituting gives

$$h_{\text{blood}} = \frac{\rho_{\text{mercury}}}{\rho_{\text{blood}}} h_{\text{mercury}} = \frac{13,600 \text{ kg/m}^3}{1050 \text{ kg/m}^3} (0.12 \text{ m}) = \mathbf{1.55 \text{ m}}$$

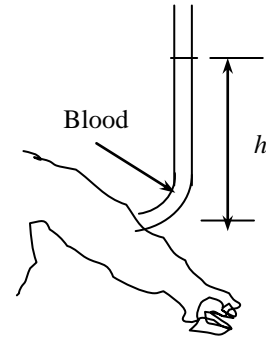

Discussion Note that the blood can rise about one and a half meters in a tube connected to the vein. This explains why IV tubes must be placed high to force a fluid into the vein of a patient.

1-73 A diver is moving at a specified depth from the water surface. The pressure exerted on the surface of the diver by water is to be determined.

Assumptions The variation of the density of water with depth is negligible.

Properties The specific gravity of seawater is given to be $SG = 1.03$. We take the density of water to be 1000 kg/m^3 .

Analysis The density of the seawater is obtained by multiplying its specific gravity by the density of water which is taken to be 1000 kg/m^3 :

$$\rho = SG \times \rho_{H_2O} = (1.03)(1000 \text{ kg/m}^3) = 1030 \text{ kg/m}^3$$

The pressure exerted on a diver at 45 m below the free surface of the sea is the absolute pressure at that location:

$$\begin{aligned} P &= P_{\text{atm}} + \rho gh \\ &= (101 \text{ kPa}) + (1030 \text{ kg/m}^3)(9.807 \text{ m/s}^2)(45 \text{ m}) \left(\frac{1 \text{ kPa}}{1000 \text{ N/m}^2} \right) \\ &= \mathbf{556 \text{ kPa}} \end{aligned}$$

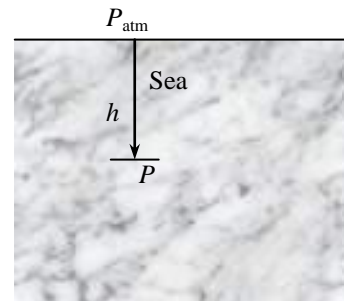

1-74 Water is poured into the U-tube from one arm and oil from the other arm. The water column height in one arm and the ratio of the heights of the two fluids in the other arm are given. The height of each fluid in that arm is to be determined.

Assumptions Both water and oil are incompressible substances.

Properties The density of oil is given to be $\rho = 790 \text{ kg/m}^3$. We take the density of water to be $\rho = 1000 \text{ kg/m}^3$.

Analysis The height of water column in the left arm of the manometer is given to be $h_{w1} = 0.70 \text{ m}$. We let the height of water and oil in the right arm to be h_{w2} and h_a , respectively. Then, $h_a = 4h_{w2}$. Noting that both arms are open to the atmosphere, the pressure at the bottom of the U-tube can be expressed as

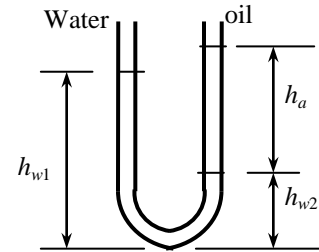

$$P_{\text{bottom}} = P_{\text{atm}} + \rho_w g h_{w1} \quad \text{and} \quad P_{\text{bottom}} = P_{\text{atm}} + \rho_w g h_{w2} + \rho_a g h_a$$

Setting them equal to each other and simplifying,

$$\rho_w g h_{w1} = \rho_w g h_{w2} + \rho_a g h_a \quad \rightarrow \quad \rho_w h_{w1} = \rho_w h_{w2} + \rho_a h_a \quad \rightarrow \quad h_{w1} = h_{w2} + (\rho_a / \rho_w) h_a$$

Noting that $h_a = 4h_{w2}$, the water and oil column heights in the second arm are determined to be

$$0.7 \text{ m} = h_{w2} + (790/1000) 4h_{w2} \quad \rightarrow \quad h_{w2} = \mathbf{0.168 \text{ m}}$$

$$0.7 \text{ m} = 0.168 \text{ m} + (790/1000) h_a \quad \rightarrow \quad h_a = \mathbf{0.673 \text{ m}}$$

Discussion Note that the fluid height in the arm that contains oil is higher. This is expected since oil is lighter than water.

1-75 A double-fluid manometer attached to an air pipe is considered. The specific gravity of one fluid is known, and the specific gravity of the other fluid is to be determined.

Assumptions 1 Densities of liquids are constant. 2 The air pressure in the tank is uniform (i.e., its variation with elevation is negligible due to its low density), and thus the pressure at the air-water interface is the same as the indicated gage pressure.

Properties The specific gravity of one fluid is given to be 13.55. We take the standard density of water to be 1000 kg/m^3 .

Analysis Starting with the pressure of air in the tank, and moving along the tube by adding (as we go down) or subtracting (as we go up) the $\rho g h$ terms until we reach the free surface where the oil tube is exposed to the atmosphere, and setting the result equal to P_{atm} give

$$P_{\text{air}} + \rho_1 g h_1 - \rho_2 g h_2 = P_{\text{atm}} \quad \rightarrow \quad P_{\text{air}} - P_{\text{atm}} = SG_2 \rho_w g h_2 - SG_1 \rho_w g h_1$$

Rearranging and solving for SG_2 ,

$$SG_2 = SG_1 \frac{h_1}{h_2} + \frac{P_{\text{air}} - P_{\text{atm}}}{\rho_w g h_2} = 13.55 \frac{0.22 \text{ m}}{0.40 \text{ m}} + \left(\frac{76 - 100 \text{ kPa}}{(1000 \text{ kg/m}^3)(9.81 \text{ m/s}^2)(0.40 \text{ m})} \right) \left(\frac{1000 \text{ kg} \cdot \text{m/s}^2}{1 \text{ kPa} \cdot \text{m}^2} \right) = \mathbf{1.34}$$

Discussion Note that the right fluid column is higher than the left, and this would imply above atmospheric pressure in the pipe for a single-fluid manometer.

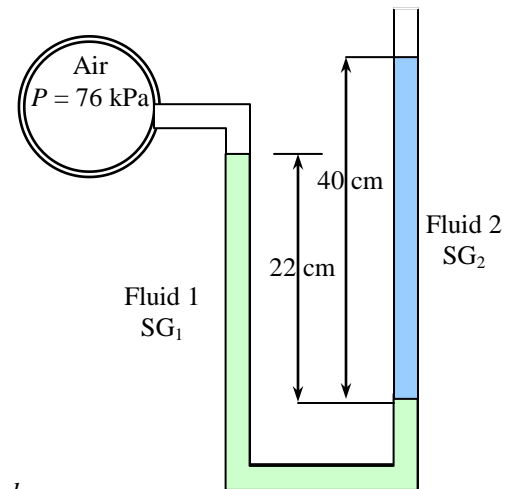

1-76 Fresh and seawater flowing in parallel horizontal pipelines are connected to each other by a double U-tube manometer. The pressure difference between the two pipelines is to be determined.

Assumptions 1 All the liquids are incompressible. 2 The effect of air column on pressure is negligible.

Properties The densities of seawater and mercury are given to be $\rho_{\text{sea}} = 1035 \text{ kg/m}^3$ and $\rho_{\text{Hg}} = 13,600 \text{ kg/m}^3$. We take the density of water to be $\rho_w = 1000 \text{ kg/m}^3$.

Analysis Starting with the pressure in the fresh water pipe (point 1) and moving along the tube by adding (as we go down) or subtracting (as we go up) the ρgh terms until we reach the sea water pipe (point 2), and setting the result equal to P_2 gives

$$P_1 + \rho_w gh_w - \rho_{\text{Hg}} gh_{\text{Hg}} - \rho_{\text{air}} gh_{\text{air}} + \rho_{\text{sea}} gh_{\text{sea}} = P_2$$

Rearranging and neglecting the effect of air column on pressure,

$$P_1 - P_2 = -\rho_w gh_w + \rho_{\text{Hg}} gh_{\text{Hg}} - \rho_{\text{sea}} gh_{\text{sea}} = g(\rho_{\text{Hg}} h_{\text{Hg}} - \rho_w h_w - \rho_{\text{sea}} h_{\text{sea}})$$

Substituting,

$$\begin{aligned} P_1 - P_2 &= (9.81 \text{ m/s}^2)[(13600 \text{ kg/m}^3)(0.1 \text{ m}) \\ &\quad - (1000 \text{ kg/m}^3)(0.6 \text{ m}) - (1035 \text{ kg/m}^3)(0.4 \text{ m})] \left(\frac{1 \text{ kN}}{1000 \text{ kg} \cdot \text{m/s}^2} \right) \\ &= 3.39 \text{ kN/m}^2 = \mathbf{3.39 \text{ kPa}} \end{aligned}$$

Therefore, the pressure in the fresh water pipe is 3.39 kPa higher than the pressure in the sea water pipe.

Discussion A 0.70-m high air column with a density of 1.2 kg/m^3 corresponds to a pressure difference of 0.008 kPa. Therefore, its effect on the pressure difference between the two pipes is negligible.

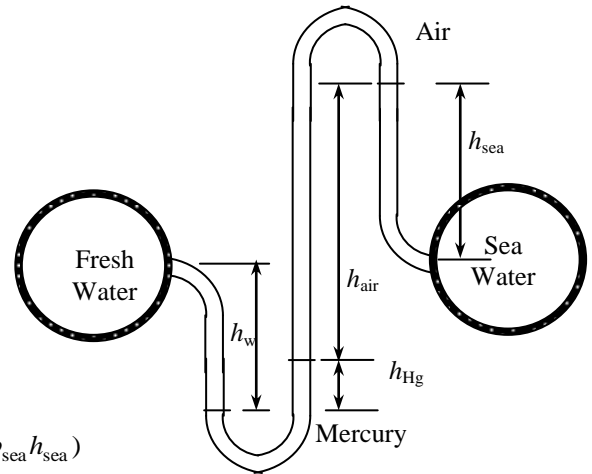

1-77 Fresh and seawater flowing in parallel horizontal pipelines are connected to each other by a double U-tube manometer. The pressure difference between the two pipelines is to be determined.

Assumptions All the liquids are incompressible.

Properties The densities of seawater and mercury are given to be $\rho_{\text{sea}} = 1035 \text{ kg/m}^3$ and $\rho_{\text{Hg}} = 13,600 \text{ kg/m}^3$. We take the density of water to be $\rho_w = 1000 \text{ kg/m}^3$. The specific gravity of oil is given to be 0.72, and thus its density is 720 kg/m^3 .

Analysis Starting with the pressure in the fresh water pipe (point 1) and moving along the tube by adding (as we go down) or subtracting (as we go up) the ρgh terms until we reach the sea water pipe (point 2), and setting the result equal to P_2 gives

$$P_1 + \rho_w gh_w - \rho_{\text{Hg}} gh_{\text{Hg}} - \rho_{\text{oil}} gh_{\text{oil}} + \rho_{\text{sea}} gh_{\text{sea}} = P_2$$

Rearranging,

$$\begin{aligned} P_1 - P_2 &= -\rho_w gh_w + \rho_{\text{Hg}} gh_{\text{Hg}} + \rho_{\text{oil}} gh_{\text{oil}} - \rho_{\text{sea}} gh_{\text{sea}} \\ &= g(\rho_{\text{Hg}} h_{\text{Hg}} + \rho_{\text{oil}} h_{\text{oil}} - \rho_w h_w - \rho_{\text{sea}} h_{\text{sea}}) \end{aligned}$$

Substituting,

$$\begin{aligned} P_1 - P_2 &= (9.81 \text{ m/s}^2)[(13600 \text{ kg/m}^3)(0.1 \text{ m}) + (720 \text{ kg/m}^3)(0.7 \text{ m}) - (1000 \text{ kg/m}^3)(0.6 \text{ m}) \\ &\quad - (1035 \text{ kg/m}^3)(0.4 \text{ m})] \left[\frac{1 \text{ kN}}{1000 \text{ kg} \cdot \text{m/s}^2} \right] \\ &= 8.34 \text{ kN/m}^2 = \mathbf{8.34 \text{ kPa}} \end{aligned}$$

Therefore, the pressure in the fresh water pipe is 8.34 kPa higher than the pressure in the sea water pipe.

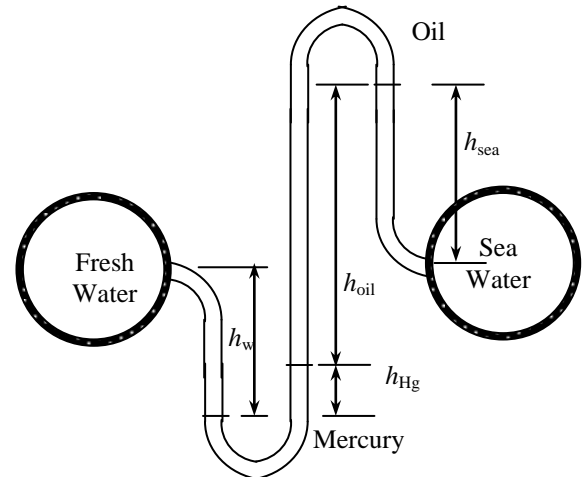

1-78 The pressure indicated by a manometer is to be determined.

Properties The specific weights of fluid A and fluid B are given to be 10 kN/m^3 and 8 kN/m^3 , respectively.

Analysis The absolute pressure P_1 is determined from

$$\begin{aligned} P_1 &= P_{\text{atm}} + (\rho gh)_A + (\rho gh)_B \\ &= P_{\text{atm}} + \gamma_A h_A + \gamma_B h_B \\ &= (758 \text{ mm Hg}) \left(\frac{0.1333 \text{ kPa}}{1 \text{ mm Hg}} \right) \\ &\quad + (10 \text{ kN/m}^3)(0.05 \text{ m}) + (8 \text{ kN/m}^3)(0.15 \text{ m}) \\ &= \mathbf{102.7 \text{ kPa}} \end{aligned}$$

Note that $1 \text{ kPa} = 1 \text{ kN/m}^2$.

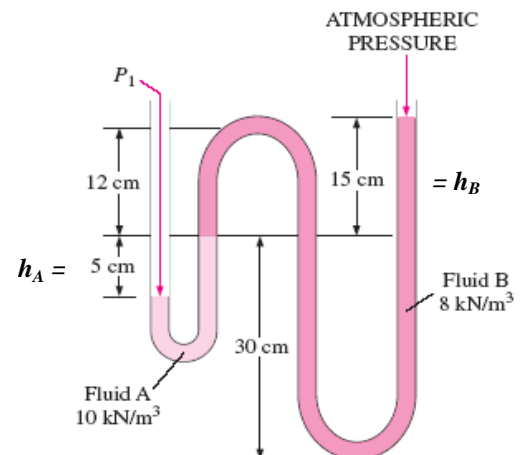

1-79 The pressure indicated by a manometer is to be determined.

Properties The specific weights of fluid A and fluid B are given to be 100 kN/m^3 and 8 kN/m^3 , respectively.

Analysis The absolute pressure P_1 is determined from

$$\begin{aligned} P_1 &= P_{\text{atm}} + (\rho gh)_A + (\rho gh)_B \\ &= P_{\text{atm}} + \gamma_A h_A + \gamma_B h_B \\ &= 90 \text{ kPa} + (100 \text{ kN/m}^3)(0.05 \text{ m}) + (8 \text{ kN/m}^3)(0.15 \text{ m}) \\ &= \mathbf{96.2 \text{ kPa}} \end{aligned}$$

Note that $1 \text{ kPa} = 1 \text{ kN/m}^2$.

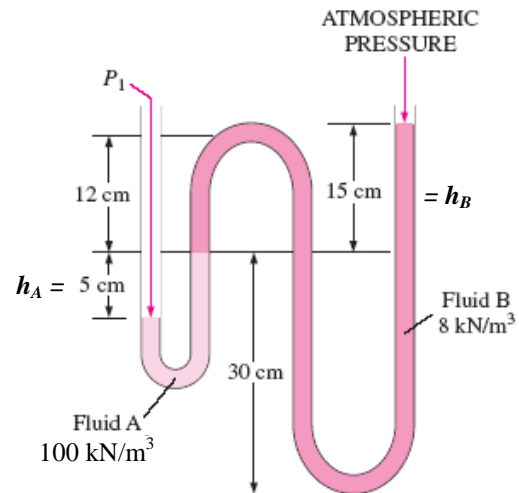

1-80 The pressure indicated by a manometer is to be determined.

Properties The specific weights of fluid A and fluid B are given to be 10 kN/m^3 and 20 kN/m^3 , respectively.

Analysis The absolute pressure P_1 is determined from

$$\begin{aligned} P_1 &= P_{\text{atm}} + (\rho gh)_A + (\rho gh)_B \\ &= P_{\text{atm}} + \gamma_A h_A + \gamma_B h_B \\ &= (720 \text{ mm Hg}) \left(\frac{0.1333 \text{ kPa}}{1 \text{ mm Hg}} \right) \\ &\quad + (10 \text{ kN/m}^3)(0.05 \text{ m}) + (20 \text{ kN/m}^3)(0.15 \text{ m}) \\ &= \mathbf{99.5 \text{ kPa}} \end{aligned}$$

Note that $1 \text{ kPa} = 1 \text{ kN/m}^2$.

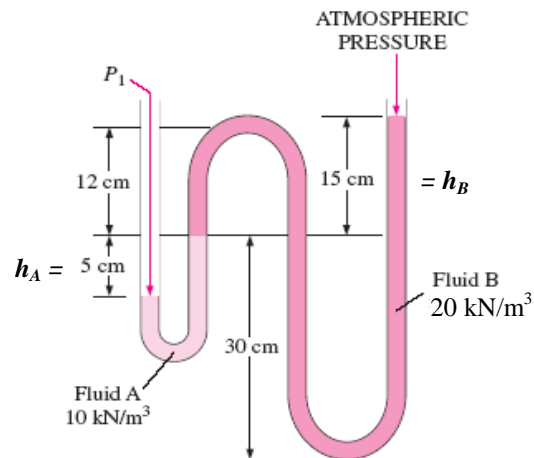

1-81 The fluid levels in a multi-fluid U-tube manometer change as a result of a pressure drop in the trapped air space. For a given pressure drop and brine level change, the area ratio is to be determined.

Assumptions 1 All the liquids are incompressible. 2 Pressure in the brine pipe remains constant. 3 The variation of pressure in the trapped air space is negligible.

Properties The specific gravities are given to be 13.56 for mercury and 1.1 for brine. We take the standard density of water to be $\rho_w = 1000 \text{ kg/m}^3$.

Analysis It is clear from the problem statement and the figure that the brine pressure is much higher than the air pressure, and when the air pressure drops by 0.7 kPa, the pressure difference between the brine and the air space increases also by the same amount.

Starting with the air pressure (point A) and moving along the tube by adding (as we go down) or subtracting (as we go up) the ρgh terms until we reach the brine pipe (point B), and setting the result equal to P_B before and after the pressure change of air give

$$\text{Before: } P_{A1} + \rho_w gh_w + \rho_{\text{Hg}} gh_{\text{Hg},1} - \rho_{\text{br}} gh_{\text{br},1} = P_B$$

$$\text{After: } P_{A2} + \rho_w gh_w + \rho_{\text{Hg}} gh_{\text{Hg},2} - \rho_{\text{br}} gh_{\text{br},2} = P_B$$

Subtracting,

$$P_{A2} - P_{A1} + \rho_{\text{Hg}} g \Delta h_{\text{Hg}} - \rho_{\text{br}} g \Delta h_{\text{br}} = 0 \rightarrow \frac{P_{A1} - P_{A2}}{\rho_w g} = SG_{\text{Hg}} \Delta h_{\text{Hg}} - SG_{\text{br}} \Delta h_{\text{br}} = 0 \quad (1)$$

where Δh_{Hg} and Δh_{br} are the changes in the differential mercury and brine column heights, respectively, due to the drop in air pressure. Both of these are positive quantities since as the mercury-brine interface drops, the differential fluid heights for both mercury and brine increase. Noting also that the volume of mercury is constant, we have $A_1 \Delta h_{\text{Hg, left}} = A_2 \Delta h_{\text{Hg, right}}$ and

$$P_{A2} - P_{A1} = -0.7 \text{ kPa} = -700 \text{ N/m}^2 = -700 \text{ kg/m} \cdot \text{s}^2$$

$$\Delta h_{\text{br}} = 0.005 \text{ m}$$

$$\Delta h_{\text{Hg}} = \Delta h_{\text{Hg, right}} + \Delta h_{\text{Hg, left}} = \Delta h_{\text{br}} + \Delta h_{\text{br}} A_2 / A_1 = \Delta h_{\text{br}} (1 + A_2 / A_1)$$

Substituting,

$$\frac{700 \text{ kg/m} \cdot \text{s}^2}{(1000 \text{ kg/m}^3)(9.81 \text{ m/s}^2)} = [13.56 \times 0.005(1 + A_2 / A_1) - (1.1 \times 0.005)] \text{ m}$$

It gives

$$A_2 / A_1 = \mathbf{0.134}$$

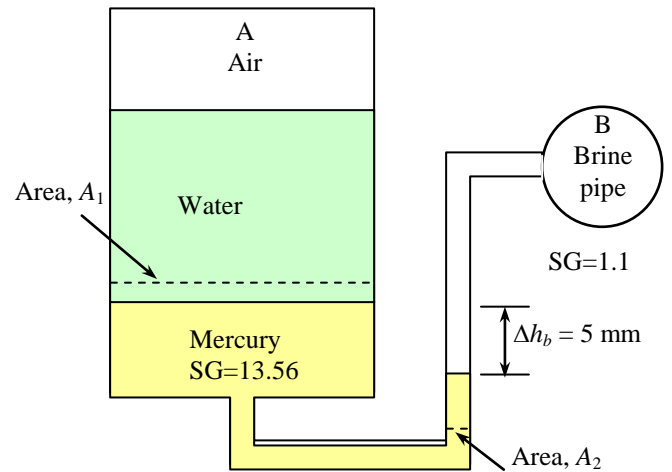

Solving Engineering Problems and EES

1-82C Despite the convenience and capability the engineering software packages offer, they are still just tools, and they will not replace the traditional engineering courses. They will simply cause a shift in emphasis in the course material from mathematics to physics. They are of great value in engineering practice, however, as engineers today rely on software packages for solving large and complex problems in a short time, and perform optimization studies efficiently.



1-83 Determine a positive real root of the following equation using EES:

$$2x^3 - 10x^{0.5} - 3x = -3$$

Solution by EES Software (Copy the following line and paste on a blank EES screen to verify solution):

$$2*x^3-10*x^{0.5}-3*x = -3$$

Answer: $x = 2.063$ (using an initial guess of $x=2$)



1-84 Solve the following system of 2 equations with 2 unknowns using EES:

$$x^3 - y^2 = 7.75$$

$$3xy + y = 3.5$$

Solution by EES Software (Copy the following lines and paste on a blank EES screen to verify solution):

$$x^3-y^2=7.75$$

$$3*x*y+y=3.5$$

Answer $x=2$ $y=0.5$



1-85 Solve the following system of 3 equations with 3 unknowns using EES:

$$x^2y - z = 1$$

$$x - 3y^{0.5} + xz = -2$$

$$x + y - z = 2$$

Solution by EES Software (Copy the following lines and paste on a blank EES screen to verify solution):

$$x^2*y-z=1$$

$$x-3*y^{0.5}+x*z=-2$$

$$x+y-z=2$$

Answer $x=1$, $y=1$, $z=0$



1-86 Solve the following system of 3 equations with 3 unknowns using EES:

$$2x - y + z = 7$$

$$3x^2 + 2y = z + 3$$

$$xy + 2z = 4$$

Solution by EES Software (Copy the following lines and paste on a blank EES screen to verify solution):

$$2*x-y+z=7$$

$$3*x^2+2*y=z+3$$

$$x*y+2*z=4$$

Answer $x=1.609$, $y=-0.9872$, $z=2.794$



1-87E Specific heat of water is to be expressed at various units using unit conversion capability of EES.

Analysis The problem is solved using EES, and the solution is given below.

EQUATION WINDOW

"GIVEN"

$$C_p = 4.18 \text{ [kJ/kg-C]}$$

"ANALYSIS"

$$C_{p,1} = C_p * \text{Convert(kJ/kg-C, kJ/kg-K)}$$

$$C_{p,2} = C_p * \text{Convert(kJ/kg-C, Btu/lbm-F)}$$

$$C_{p,3} = C_p * \text{Convert(kJ/kg-C, Btu/lbm-R)}$$

$$C_{p,4} = C_p * \text{Convert(kJ/kg-C, kCal/kg-C)}$$

FORMATTED EQUATIONS WINDOW

GIVEN

$$C_p = 4.18 \text{ [kJ/kg-C]}$$

ANALYSIS

$$C_{p,1} = C_p \cdot \left| 1 \cdot \frac{\text{kJ/kg-K}}{\text{kJ/kg-C}} \right|$$

$$C_{p,2} = C_p \cdot \left| 0.238846 \cdot \frac{\text{Btu/lbm-F}}{\text{kJ/kg-C}} \right|$$

$$C_{p,3} = C_p \cdot \left| 0.238846 \cdot \frac{\text{Btu/lbm-R}}{\text{kJ/kg-C}} \right|$$

$$C_{p,4} = C_p \cdot \left| 0.238846 \cdot \frac{\text{kCal/kg-C}}{\text{kJ/kg-C}} \right|$$

SOLUTION

$$C_p = 4.18 \text{ [kJ/kg-C]}$$

$$C_{p,1} = 4.18 \text{ [kJ/kg-K]}$$

$$C_{p,2} = 0.9984 \text{ [Btu/lbm-F]}$$

$$C_{p,3} = 0.9984 \text{ [Btu/lbm-R]}$$

$$C_{p,4} = 0.9984 \text{ [kCal/kg-C]}$$

Review Problems

1-88 The gravitational acceleration changes with altitude. Accounting for this variation, the weights of a body at different locations are to be determined.

Analysis The weight of an 80-kg man at various locations is obtained by substituting the altitude z (values in m) into the relation

$$W = mg = (80\text{kg})(9.807 - 3.32 \times 10^{-6} z \text{ m/s}^2) \left(\frac{1\text{N}}{1\text{kg} \cdot \text{m/s}^2} \right)$$

Sea level: ($z = 0$ m): $W = 80 \times (9.807 - 3.32 \times 10^{-6} \times 0) = 80 \times 9.807 = \mathbf{784.6 \text{ N}}$

Denver: ($z = 1610$ m): $W = 80 \times (9.807 - 3.32 \times 10^{-6} \times 1610) = 80 \times 9.802 = \mathbf{784.2 \text{ N}}$

Mt. Ev.: ($z = 8848$ m): $W = 80 \times (9.807 - 3.32 \times 10^{-6} \times 8848) = 80 \times 9.778 = \mathbf{782.2 \text{ N}}$

1-89E A man is considering buying a 12-oz steak for \$5.50, or a 300-g steak for \$5.20. The steak that is a better buy is to be determined.

Assumptions The steaks are of identical quality.

Analysis To make a comparison possible, we need to express the cost of each steak on a common basis. Let us choose 1 kg as the basis for comparison. Using proper conversion factors, the unit cost of each steak is determined to be

12 ounce steak:

$$\text{Unit Cost} = \left(\frac{\$5.50}{12 \text{ oz}} \right) \left(\frac{16 \text{ oz}}{1 \text{ lbm}} \right) \left(\frac{1 \text{ lbm}}{0.45359 \text{ kg}} \right) = \mathbf{\$16.17/\text{kg}}$$

300 gram steak:

$$\text{Unit Cost} = \left(\frac{\$5.20}{300 \text{ g}} \right) \left(\frac{1000 \text{ g}}{1 \text{ kg}} \right) = \mathbf{\$17.33/\text{kg}}$$

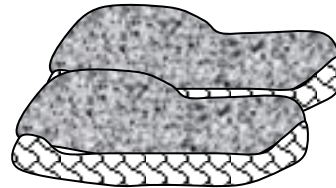

Therefore, the steak at the traditional market is a better buy.

1.90E The mass of a substance is given. Its weight is to be determined in various units.

Analysis Applying Newton's second law, the weight is determined in various units to be

$$W = mg = (1 \text{ kg})(9.81 \text{ m/s}^2) \left(\frac{1 \text{ N}}{1 \text{ kg} \cdot \text{m/s}^2} \right) = \mathbf{9.81 \text{ N}}$$

$$W = mg = (1 \text{ kg})(9.81 \text{ m/s}^2) \left(\frac{1 \text{ kN}}{1000 \text{ kg} \cdot \text{m/s}^2} \right) = \mathbf{0.00981 \text{ kN}}$$

$$W = mg = (1 \text{ kg})(9.81 \text{ m/s}^2) = \mathbf{1 \text{ kg} \cdot \text{m/s}^2}$$

$$W = mg = (1 \text{ kg})(9.81 \text{ m/s}^2) \left(\frac{1 \text{ N}}{1 \text{ kg} \cdot \text{m/s}^2} \right) \left(\frac{1 \text{ kgf}}{9.81 \text{ N}} \right) = \mathbf{1 \text{ kgf}}$$

$$W = mg = (1 \text{ kg}) \left(\frac{2.205 \text{ lbm}}{1 \text{ kg}} \right) (32.2 \text{ ft/s}^2) = \mathbf{71 \text{ lbm} \cdot \text{ft/s}^2}$$

$$W = mg = (1 \text{ kg}) \left(\frac{2.205 \text{ lbm}}{1 \text{ kg}} \right) (32.2 \text{ ft/s}^2) \left(\frac{1 \text{ lbf}}{32.2 \text{ lbm} \cdot \text{ft/s}^2} \right) = \mathbf{2.21 \text{ lbf}}$$

1-91 A hydraulic lift is used to lift a weight. The diameter of the piston on which the weight to be placed is to be determined.

Assumptions 1 The cylinders of the lift are vertical. 2 There are no leaks. 3 Atmospheric pressure act on both sides, and thus it can be disregarded.

Analysis Noting that pressure is force per unit area, the pressure on the smaller piston is determined from

$$\begin{aligned} P_1 &= \frac{F_1}{A_1} = \frac{m_1 g}{\pi D_1^2 / 4} \\ &= \frac{(25 \text{ kg})(9.81 \text{ m/s}^2)}{\pi(0.10 \text{ m})^2 / 4} \left(\frac{1 \text{ kN}}{1000 \text{ kg} \cdot \text{m/s}^2} \right) \\ &= 31.23 \text{ kN/m}^2 = 31.23 \text{ kPa} \end{aligned}$$

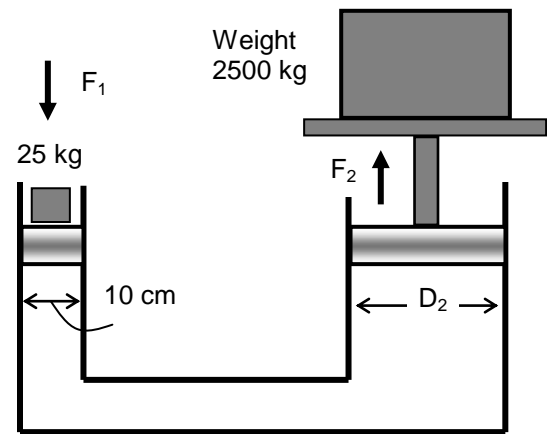

From Pascal's principle, the pressure on the greater piston is equal to that in the smaller piston. Then, the needed diameter is determined from

$$P_1 = P_2 = \frac{F_2}{A_2} = \frac{m_2 g}{\pi D_2^2 / 4} \rightarrow 31.23 \text{ kN/m}^2 = \frac{(2500 \text{ kg})(9.81 \text{ m/s}^2)}{\pi D_2^2 / 4} \left(\frac{1 \text{ kN}}{1000 \text{ kg} \cdot \text{m/s}^2} \right) \rightarrow D_2 = \mathbf{1.0 \text{ m}}$$

Discussion Note that large weights can be raised by little effort in hydraulic lift by making use of Pascal's principle.

1-92E The efficiency of a refrigerator increases by 3% per °C rise in the minimum temperature. This increase is to be expressed per °F, K, and R rise in the minimum temperature.

Analysis The magnitudes of 1 K and 1°C are identical, so are the magnitudes of 1 R and 1°F. Also, a change of 1 K or 1°C in temperature corresponds to a change of 1.8 R or 1.8°F. Therefore, the increase in efficiency is

- (a) **3%** for each K rise in temperature, and
- (b), (c) $3/1.8 = \mathbf{1.67\%}$ for each R or °F rise in temperature.

1-93E Hyperthermia of 5°C is considered fatal. This fatal level temperature change of body temperature is to be expressed in °F, K, and R.

Analysis The magnitudes of 1 K and 1°C are identical, so are the magnitudes of 1 R and 1°F. Also, a change of 1 K or 1°C in temperature corresponds to a change of 1.8 R or 1.8°F. Therefore, the fatal level of hypothermia is

- (a) **5 K**
- (b) $5 \times 1.8 = \mathbf{9^\circ \text{F}}$
- (c) $5 \times 1.8 = \mathbf{9 \text{ R}}$

1-94E A house is losing heat at a rate of 1800 kJ/h per °C temperature difference between the indoor and the outdoor temperatures. The rate of heat loss is to be expressed per °F, K, and R of temperature difference between the indoor and the outdoor temperatures.

Analysis The magnitudes of 1 K and 1°C are identical, so are the magnitudes of 1 R and 1°F. Also, a change of 1 K or 1°C in temperature corresponds to a change of 1.8 R or 1.8°F. Therefore, the rate of heat loss from the house is

- (a) **1800 kJ/h** per K difference in temperature, and
 (b), (c) $1800/1.8 = \mathbf{1000 \text{ kJ/h}}$ per R or °F rise in temperature.

1-95 The average temperature of the atmosphere is expressed as $T_{\text{atm}} = 288.15 - 6.5z$ where z is altitude in km. The temperature outside an airplane cruising at 12,000 m is to be determined.

Analysis Using the relation given, the average temperature of the atmosphere at an altitude of 12,000 m is determined to be

$$\begin{aligned} T_{\text{atm}} &= 288.15 - 6.5z \\ &= 288.15 - 6.5 \times 12 \\ &= \mathbf{210.15 \text{ K} = -63^\circ\text{C}} \end{aligned}$$

Discussion This is the “average” temperature. The actual temperature at different times can be different.

1-96 A new “Smith” absolute temperature scale is proposed, and a value of 1000 S is assigned to the boiling point of water. The ice point on this scale, and its relation to the Kelvin scale are to be determined.

Analysis All linear absolute temperature scales read zero at absolute zero pressure, and are constant multiples of each other. For example, $T(\text{R}) = 1.8 T(\text{K})$. That is, multiplying a temperature value in K by 1.8 will give the same temperature in R.

The proposed temperature scale is an acceptable absolute temperature scale since it differs from the other absolute temperature scales by a constant only. The boiling temperature of water in the Kelvin and the Smith scales are 373.15 K and 1000 S, respectively. Therefore, these two temperature scales are related to each other by

$$T(\text{S}) = \frac{1000}{373.15} T(\text{K}) = \mathbf{2.6799 T(\text{K})}$$

The ice point of water on the Smith scale is

$$T(\text{S})_{\text{ice}} = 2.6799 T(\text{K})_{\text{ice}} = 2.6799 \times 273.15 = \mathbf{732.0 \text{ S}}$$



1-97E An expression for the equivalent wind chill temperature is given in English units. It is to be converted to SI units.

Analysis The required conversion relations are $1 \text{ mph} = 1.609 \text{ km/h}$ and $T(^{\circ}\text{F}) = 1.8T(^{\circ}\text{C}) + 32$. The first thought that comes to mind is to replace $T(^{\circ}\text{F})$ in the equation by its equivalent $1.8T(^{\circ}\text{C}) + 32$, and V in mph by 1.609 km/h , which is the “regular” way of converting units. However, the equation we have is not a regular dimensionally homogeneous equation, and thus the regular rules do not apply. The V in the equation is a constant whose value is equal to the numerical value of the velocity in mph. Therefore, if V is given in km/h, we should divide it by 1.609 to convert it to the desired unit of mph. That is,

$$T_{\text{equiv}}(^{\circ}\text{F}) = 91.4 - [91.4 - T_{\text{ambient}}(^{\circ}\text{F})][0.475 - 0.0203(V / 1.609) + 0.304\sqrt{V / 1.609}]$$

or

$$T_{\text{equiv}}(^{\circ}\text{F}) = 91.4 - [91.4 - T_{\text{ambient}}(^{\circ}\text{F})][0.475 - 0.0126V + 0.240\sqrt{V}]$$

where V is in km/h. Now the problem reduces to converting a temperature in $^{\circ}\text{F}$ to a temperature in $^{\circ}\text{C}$, using the proper convection relation:

$$1.8T_{\text{equiv}}(^{\circ}\text{C}) + 32 = 91.4 - [91.4 - (1.8T_{\text{ambient}}(^{\circ}\text{C}) + 32)][0.475 - 0.0126V + 0.240\sqrt{V}]$$

which simplifies to

$$T_{\text{equiv}}(^{\circ}\text{C}) = 33.0 - (33.0 - T_{\text{ambient}})(0.475 - 0.0126V + 0.240\sqrt{V})$$

where the ambient air temperature is in $^{\circ}\text{C}$.



1-98E Problem 1-97E is reconsidered. The equivalent wind-chill temperatures in $^{\circ}\text{F}$ as a function of wind velocity in the range of 4 mph to 40 mph for the ambient temperatures of 20, 40, and 60°F are to be plotted, and the results are to be discussed.

Analysis The problem is solved using EES, and the solution is given below.

T_ambient=20

"V=20"

T_equiv=91.4-(91.4-T_ambient)*(0.475 - 0.0203*V + 0.304*sqrt(V))

V [mph]	T _{equiv} [F]
4	59.94
8	54.59
12	51.07
16	48.5
20	46.54
24	45.02
28	43.82
32	42.88
36	42.16
40	41.61

The table is for $T_{\text{ambient}}=60^{\circ}\text{F}$

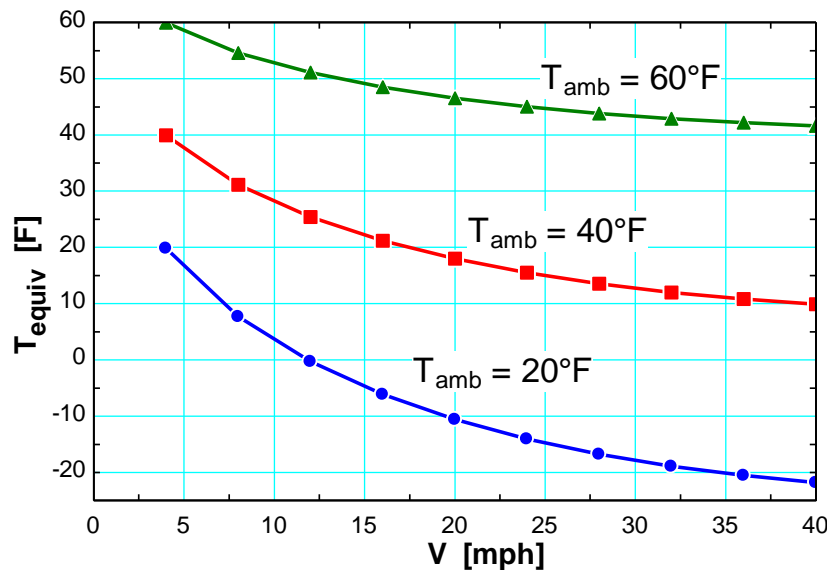

1-99 A vertical piston-cylinder device contains a gas. Some weights are to be placed on the piston to increase the gas pressure. The local atmospheric pressure and the mass of the weights that will double the pressure of the gas are to be determined.

Assumptions Friction between the piston and the cylinder is negligible.

Analysis The gas pressure in the piston-cylinder device initially depends on the local atmospheric pressure and the weight of the piston. Balancing the vertical forces yield

$$P_{\text{atm}} = P - \frac{m_{\text{piston}}g}{A} = 100 \text{ kPa} - \frac{(5 \text{ kg})(9.81 \text{ m/s}^2)}{\pi(0.12 \text{ m}^2)/4} \left(\frac{1 \text{ kN}}{1000 \text{ kg} \cdot \text{m/s}^2} \right) = 95.66 \text{ kN/m}^2 = \mathbf{95.7 \text{ kPa}}$$

The force balance when the weights are placed is used to determine the mass of the weights

$$P = P_{\text{atm}} + \frac{(m_{\text{piston}} + m_{\text{weights}})g}{A}$$

$$200 \text{ kPa} = 95.66 \text{ kPa} + \frac{(5 \text{ kg} + m_{\text{weights}})(9.81 \text{ m/s}^2)}{\pi(0.12 \text{ m}^2)/4} \left(\frac{1 \text{ kN}}{1000 \text{ kg} \cdot \text{m/s}^2} \right) \rightarrow m_{\text{weights}} = \mathbf{115 \text{ kg}}$$

A large mass is needed to double the pressure.

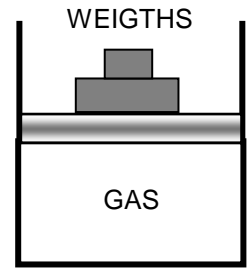

1-100 One section of the duct of an air-conditioning system is laid underwater. The upward force the water will exert on the duct is to be determined.

Assumptions 1 The diameter given is the outer diameter of the duct (or, the thickness of the duct material is negligible). **2** The weight of the duct and the air in is negligible.

Properties The density of air is given to be $\rho = 1.30 \text{ kg/m}^3$. We take the density of water to be 1000 kg/m^3 .

Analysis Noting that the weight of the duct and the air in it is negligible, the net upward force acting on the duct is the buoyancy force exerted by water. The volume of the underground section of the duct is

$$V = AL = (\pi D^2 / 4)L = [\pi(0.15 \text{ m})^2 / 4](35 \text{ m}) = 0.6185 \text{ m}^3$$

Then the buoyancy force becomes

$$F_B = \rho g V = (1000 \text{ kg/m}^3)(9.81 \text{ m/s}^2)(0.6185 \text{ m}^3) \left(\frac{1 \text{ kN}}{1000 \text{ kg} \cdot \text{m/s}^2} \right) = \mathbf{6.07 \text{ kN}}$$

Discussion The upward force exerted by water on the duct is 6.07 kN, which is equivalent to the weight of a mass of 619 kg. Therefore, this force must be treated seriously.

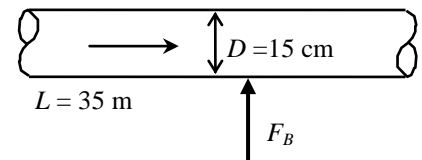

1-101E The average body temperature of a person rises by about 2°C during strenuous exercise. This increase in temperature is to be expressed in $^{\circ}\text{F}$, K , and R .

Analysis The magnitudes of 1 K and 1°C are identical, so are the magnitudes of 1 R and 1°F . Also, a change of 1 K or 1°C in temperature corresponds to a change of 1.8 R or 1.8°F . Therefore, the rise in the body temperature during strenuous exercise is

- (a) **2 K**
- (b) $2 \times 1.8 = \mathbf{3.6^{\circ}\text{F}}$
- (c) $2 \times 1.8 = \mathbf{3.6\text{ R}}$

1-102 A helium balloon tied to the ground carries 2 people. The acceleration of the balloon when it is first released is to be determined.

Assumptions The weight of the cage and the ropes of the balloon is negligible.

Properties The density of air is given to be $\rho = 1.16\text{ kg/m}^3$. The density of helium gas is $1/7^{\text{th}}$ of this.

Analysis The buoyancy force acting on the balloon is

$$\begin{aligned} V_{\text{balloon}} &= 4\pi r^3/3 = 4\pi(6\text{ m})^3/3 = 904.8\text{ m}^3 \\ F_B &= \rho_{\text{air}} g V_{\text{balloon}} \\ &= (1.16\text{ kg/m}^3)(9.81\text{ m/s}^2)(904.8\text{ m}^3) \left(\frac{1\text{ N}}{1\text{ kg} \cdot \text{m/s}^2} \right) = 10,296\text{ N} \end{aligned}$$

The total mass is

$$\begin{aligned} m_{\text{He}} &= \rho_{\text{He}} V = \left(\frac{1.16}{7}\text{ kg/m}^3 \right) (904.8\text{ m}^3) = 149.9\text{ kg} \\ m_{\text{total}} &= m_{\text{He}} + m_{\text{people}} = 149.9 + 2 \times 85 = 319.9\text{ kg} \end{aligned}$$

The total weight is

$$W = m_{\text{total}} g = (319.9\text{ kg})(9.81\text{ m/s}^2) \left(\frac{1\text{ N}}{1\text{ kg} \cdot \text{m/s}^2} \right) = 3138\text{ N}$$

Thus the net force acting on the balloon is

$$F_{\text{net}} = F_B - W = 10,296 - 3138 = 7157\text{ N}$$

Then the acceleration becomes

$$a = \frac{F_{\text{net}}}{m_{\text{total}}} = \frac{7157\text{ N}}{319.9\text{ kg}} \left(\frac{1\text{ kg} \cdot \text{m/s}^2}{1\text{ N}} \right) = \mathbf{22.4\text{ m/s}^2}$$





1-103 Problem 1-102 is reconsidered. The effect of the number of people carried in the balloon on acceleration is to be investigated. Acceleration is to be plotted against the number of people, and the results are to be discussed.

Analysis The problem is solved using EES, and the solution is given below.

"Given"

D=12 [m]
 N_person=2
 m_person=85 [kg]
 rho_air=1.16 [kg/m^3]
 rho_He=rho_air/7

"Analysis"

g=9.81 [m/s^2]
 V_ballon=pi*D^3/6
 F_B=rho_air*g*V_ballon
 m_He=rho_He*V_ballon
 m_people=N_person*m_person
 m_total=m_He+m_people
 W=m_total*g
 F_net=F_B-W
 a=F_net/m_total

N _{person}	a [m/s ²]
1	34
2	22.36
3	15.61
4	11.2
5	8.096
6	5.79
7	4.01
8	2.595
9	1.443
10	0.4865

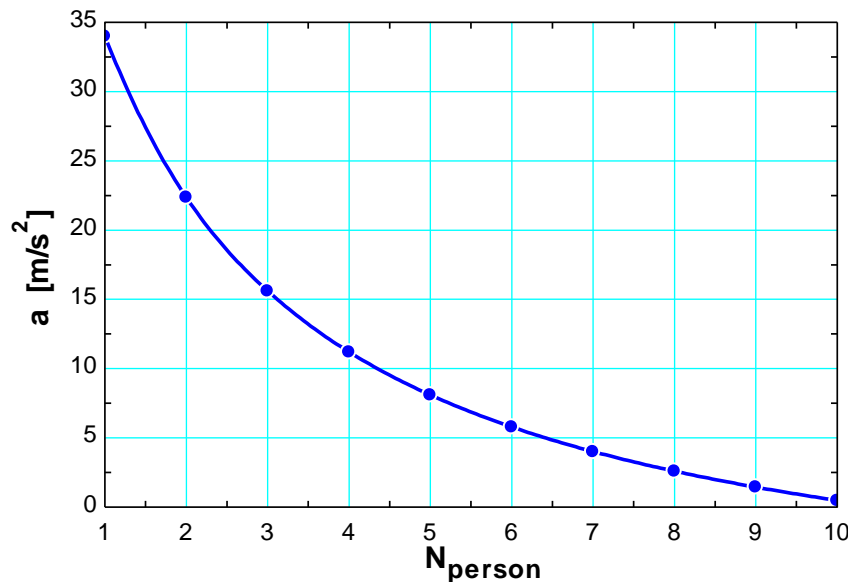

1-104 A balloon is filled with helium gas. The maximum amount of load the balloon can carry is to be determined.

Assumptions The weight of the cage and the ropes of the balloon is negligible.

Properties The density of air is given to be $\rho = 1.16 \text{ kg/m}^3$. The density of helium gas is 1/7th of this.

Analysis The buoyancy force acting on the balloon is

$$\begin{aligned} V_{\text{balloon}} &= 4\pi r^3/3 = 4\pi(6 \text{ m})^3/3 = 904.8 \text{ m}^3 \\ F_B &= \rho_{\text{air}} g V_{\text{balloon}} \\ &= (1.16 \text{ kg/m}^3)(9.81 \text{ m/s}^2)(904.8 \text{ m}^3) \left(\frac{1 \text{ N}}{1 \text{ kg} \cdot \text{m/s}^2} \right) = 10,296 \text{ N} \end{aligned}$$

The mass of helium is

$$m_{\text{He}} = \rho_{\text{He}} V = \left(\frac{1.16}{7} \text{ kg/m}^3 \right) (904.8 \text{ m}^3) = 149.9 \text{ kg}$$

In the limiting case, the net force acting on the balloon will be zero. That is, the buoyancy force and the weight will balance each other:

$$\begin{aligned} W &= mg = F_B \\ m_{\text{total}} &= \frac{F_B}{g} = \frac{10,296 \text{ N}}{9.81 \text{ m/s}^2} = 1050 \text{ kg} \end{aligned}$$

Thus,

$$m_{\text{people}} = m_{\text{total}} - m_{\text{He}} = 1050 - 149.9 = \mathbf{900 \text{ kg}}$$



1-105 A 6-m high cylindrical container is filled with equal volumes of water and oil. The pressure difference between the top and the bottom of the container is to be determined.

Properties The density of water is given to be $\rho = 1000 \text{ kg/m}^3$. The specific gravity of oil is given to be 0.85.

Analysis The density of the oil is obtained by multiplying its specific gravity by the density of water,

$$\rho = SG \times \rho_{\text{H}_2\text{O}} = (0.85)(1000 \text{ kg/m}^3) = 850 \text{ kg/m}^3$$

The pressure difference between the top and the bottom of the cylinder is the sum of the pressure differences across the two fluids,

$$\begin{aligned} \Delta P_{\text{total}} &= \Delta P_{\text{oil}} + \Delta P_{\text{water}} = (\rho g h)_{\text{oil}} + (\rho g h)_{\text{water}} \\ &= \left[(850 \text{ kg/m}^3)(9.81 \text{ m/s}^2)(3 \text{ m}) + (1000 \text{ kg/m}^3)(9.81 \text{ m/s}^2)(3 \text{ m}) \right] \left(\frac{1 \text{ kPa}}{1000 \text{ N/m}^2} \right) \\ &= \mathbf{54.4 \text{ kPa}} \end{aligned}$$

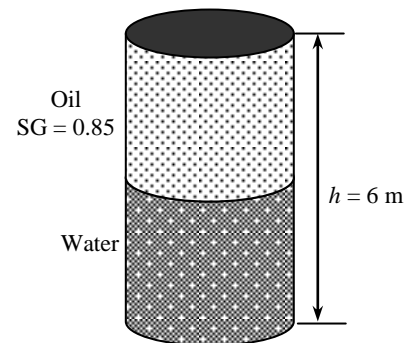

1-106 The pressure of a gas contained in a vertical piston-cylinder device is measured to be 180 kPa. The mass of the piston is to be determined.

Assumptions There is no friction between the piston and the cylinder.

Analysis Drawing the free body diagram of the piston and balancing the vertical forces yield

$$\begin{aligned}
 W &= PA - P_{\text{atm}} A \\
 mg &= (P - P_{\text{atm}})A \\
 (m)(9.81 \text{ m/s}^2) &= (180 - 100 \text{ kPa})(25 \times 10^{-4} \text{ m}^2) \left(\frac{1000 \text{ kg/m} \cdot \text{s}^2}{1 \text{ kPa}} \right)
 \end{aligned}$$

It yields $m = \mathbf{20.4 \text{ kg}}$

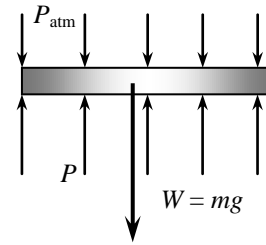

1-107 The gage pressure in a pressure cooker is maintained constant at 100 kPa by a petcock. The mass of the petcock is to be determined.

Assumptions There is no blockage of the pressure release valve.

Analysis Atmospheric pressure is acting on all surfaces of the petcock, which balances itself out. Therefore, it can be disregarded in calculations if we use the gage pressure as the cooker pressure. A force balance on the petcock ($\Sigma F_y = 0$) yields

$$\begin{aligned}
 W &= P_{\text{gage}} A \\
 m &= \frac{P_{\text{gage}} A}{g} = \frac{(100 \text{ kPa})(4 \times 10^{-6} \text{ m}^2)}{9.81 \text{ m/s}^2} \left(\frac{1000 \text{ kg/m} \cdot \text{s}^2}{1 \text{ kPa}} \right) \\
 &= \mathbf{0.0408 \text{ kg}}
 \end{aligned}$$

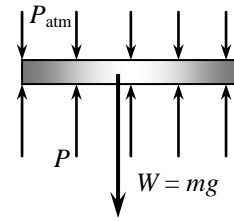

1-108 A glass tube open to the atmosphere is attached to a water pipe, and the pressure at the bottom of the tube is measured. It is to be determined how high the water will rise in the tube.

Properties The density of water is given to be $\rho = 1000 \text{ kg/m}^3$.

Analysis The pressure at the bottom of the tube can be expressed as

$$P = P_{\text{atm}} + (\rho gh)_{\text{tube}}$$

Solving for h ,

$$\begin{aligned}
 h &= \frac{P - P_{\text{atm}}}{\rho g} \\
 &= \frac{(110 - 99) \text{ kPa}}{(1000 \text{ kg/m}^3)(9.81 \text{ m/s}^2)} \left(\frac{1 \text{ kg} \cdot \text{m/s}^2}{1 \text{ N}} \right) \left(\frac{1000 \text{ N/m}^2}{1 \text{ kPa}} \right) \\
 &= \mathbf{1.12 \text{ m}}
 \end{aligned}$$

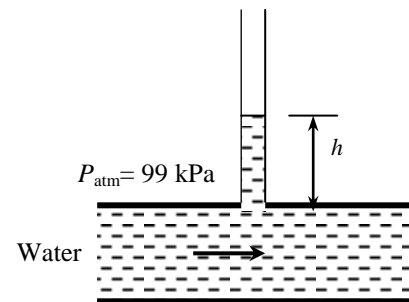

1-109E Equal volumes of water and oil are poured into a U-tube from different arms, and the oil side is pressurized until the contact surface of the two fluids moves to the bottom and the liquid levels in both arms become the same. The excess pressure applied on the oil side is to be determined.

Assumptions 1 Both water and oil are incompressible substances. 2 Oil does not mix with water. 3 The cross-sectional area of the U-tube is constant.

Properties The density of oil is given to be $\rho_{oil} = 49.3 \text{ lbf/ft}^3$. We take the density of water to be $\rho_w = 62.4 \text{ lbf/ft}^3$.

Analysis Noting that the pressure of both the water and the oil is the same at the contact surface, the pressure at this surface can be expressed as

$$P_{\text{contact}} = P_{\text{blow}} + \rho_a g h_a = P_{\text{atm}} + \rho_w g h_w$$

Noting that $h_a = h_w$ and rearranging,

$$\begin{aligned} P_{\text{gage,blow}} &= P_{\text{blow}} - P_{\text{atm}} = (\rho_w - \rho_{oil}) g h \\ &= (62.4 - 49.3 \text{ lbf/ft}^3)(32.2 \text{ ft/s}^2)(30/12 \text{ ft}) \left(\frac{1 \text{ lbf}}{32.2 \text{ lbf} \cdot \text{ft/s}^2} \right) \left(\frac{1 \text{ ft}^2}{144 \text{ in}^2} \right) \\ &= \mathbf{0.227 \text{ psi}} \end{aligned}$$

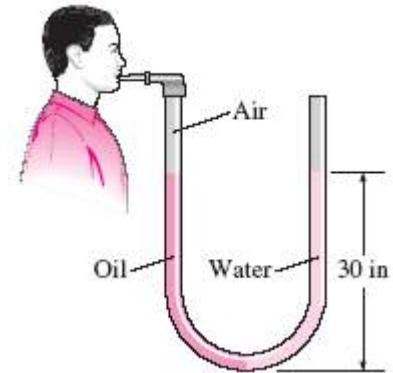

Discussion When the person stops blowing, the oil will rise and some water will flow into the right arm. It can be shown that when the curvature effects of the tube are disregarded, the differential height of water will be 23.7 in to balance 30-in of oil.

1-110 A barometer is used to measure the altitude of a plane relative to the ground. The barometric readings at the ground and in the plane are given. The altitude of the plane is to be determined.

Assumptions The variation of air density with altitude is negligible.

Properties The densities of air and mercury are given to be $\rho = 1.20 \text{ kg/m}^3$ and $\rho = 13,600 \text{ kg/m}^3$.

Analysis Atmospheric pressures at the location of the plane and the ground level are

$$\begin{aligned} P_{\text{plane}} &= (\rho g h)_{\text{plane}} \\ &= (13,600 \text{ kg/m}^3)(9.81 \text{ m/s}^2)(0.690 \text{ m}) \left(\frac{1 \text{ N}}{1 \text{ kg} \cdot \text{m/s}^2} \right) \left(\frac{1 \text{ kPa}}{1000 \text{ N/m}^2} \right) \\ &= 92.06 \text{ kPa} \end{aligned}$$

$$\begin{aligned} P_{\text{ground}} &= (\rho g h)_{\text{ground}} \\ &= (13,600 \text{ kg/m}^3)(9.81 \text{ m/s}^2)(0.753 \text{ m}) \left(\frac{1 \text{ N}}{1 \text{ kg} \cdot \text{m/s}^2} \right) \left(\frac{1 \text{ kPa}}{1000 \text{ N/m}^2} \right) \\ &= 100.46 \text{ kPa} \end{aligned}$$

Taking an air column between the airplane and the ground and writing a force balance per unit base area, we obtain

$$\begin{aligned} W_{\text{air}} / A &= P_{\text{ground}} - P_{\text{plane}} \\ (\rho g h)_{\text{air}} &= P_{\text{ground}} - P_{\text{plane}} \\ (1.20 \text{ kg/m}^3)(9.81 \text{ m/s}^2)(h) \left(\frac{1 \text{ N}}{1 \text{ kg} \cdot \text{m/s}^2} \right) \left(\frac{1 \text{ kPa}}{1000 \text{ N/m}^2} \right) &= (100.46 - 92.06) \text{ kPa} \end{aligned}$$

It yields

$$h = \mathbf{714 \text{ m}}$$

which is also the altitude of the airplane.

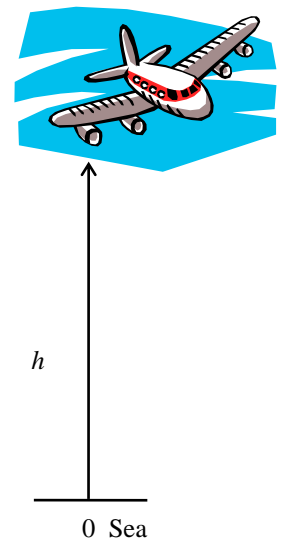

1-111E A water pipe is connected to a double-U manometer whose free arm is open to the atmosphere. The absolute pressure at the center of the pipe is to be determined.

Assumptions 1 All the liquids are incompressible. **2** The solubility of the liquids in each other is negligible.

Properties The specific gravities of mercury and oil are given to be 13.6 and 0.80, respectively. We take the density of water to be $\rho_w = 62.4 \text{ lbm/ft}^3$.

Analysis Starting with the pressure at the center of the water pipe, and moving along the tube by adding (as we go down) or subtracting (as we go up) the ρgh terms until we reach the free surface of oil where the oil tube is exposed to the atmosphere, and setting the result equal to P_{atm} gives

$$P_{\text{water pipe}} - \rho_{\text{water}} gh_{\text{water}} + \rho_{\text{oil}} gh_{\text{oil}} - \rho_{\text{Hg}} gh_{\text{Hg}} - \rho_{\text{oil}} gh_{\text{oil}} = P_{\text{atm}}$$

Solving for $P_{\text{water pipe}}$,

$$P_{\text{water pipe}} = P_{\text{atm}} + \rho_{\text{water}} g(h_{\text{water}} - SG_{\text{oil}}h_{\text{oil}} + SG_{\text{Hg}}h_{\text{Hg}} + SG_{\text{oil}}h_{\text{oil}})$$

Substituting,

$$\begin{aligned} P_{\text{water pipe}} &= 14.2 \text{ psia} + (62.4 \text{ lbm/ft}^3)(32.2 \text{ ft/s}^2)[(20/12 \text{ ft}) - 0.8(60/12 \text{ ft}) + 13.6(25/12 \text{ ft}) \\ &\quad + 0.8(30/12 \text{ ft})] \times \left(\frac{1 \text{ lbf}}{32.2 \text{ lbm} \cdot \text{ft/s}^2} \right) \left(\frac{1 \text{ ft}^2}{144 \text{ in}^2} \right) \\ &= \mathbf{26.4 \text{ psia}} \end{aligned}$$

Therefore, the absolute pressure in the water pipe is 26.4 psia.

Discussion Note that jumping horizontally from one tube to the next and realizing that pressure remains the same in the same fluid simplifies the analysis greatly.

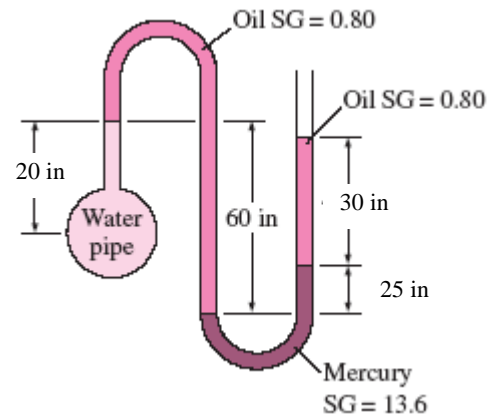

1-112 A gasoline line is connected to a pressure gage through a double-U manometer. For a given reading of the pressure gage, the gage pressure of the gasoline line is to be determined.

Assumptions 1 All the liquids are incompressible. **2** The effect of air column on pressure is negligible.

Properties The specific gravities of oil, mercury, and gasoline are given to be 0.79, 13.6, and 0.70, respectively. We take the density of water to be $\rho_w = 1000 \text{ kg/m}^3$.

Analysis Starting with the pressure indicated by the pressure gage and moving along the tube by adding (as we go down) or subtracting (as we go up) the ρgh terms until we reach the gasoline pipe, and setting the result equal to P_{gasoline} gives

$$P_{\text{gage}} - \rho_w gh_w + \rho_{\text{oil}} gh_{\text{oil}} - \rho_{\text{Hg}} gh_{\text{Hg}} - \rho_{\text{gasoline}} gh_{\text{gasoline}} = P_{\text{gasoline}}$$

Rearranging,

$$P_{\text{gasoline}} = P_{\text{gage}} - \rho_w g(h_w - SG_{\text{oil}}h_{\text{oil}} + SG_{\text{Hg}}h_{\text{Hg}} + SG_{\text{gasoline}}h_{\text{gasoline}})$$

Substituting,

$$\begin{aligned} P_{\text{gasoline}} &= 370 \text{ kPa} - (1000 \text{ kg/m}^3)(9.81 \text{ m/s}^2)[(0.45 \text{ m}) - 0.79(0.5 \text{ m}) + 13.6(0.1 \text{ m}) + 0.70(0.22 \text{ m})] \\ &\times \left(\frac{1 \text{ kN}}{1000 \text{ kg} \cdot \text{m/s}^2} \right) \left(\frac{1 \text{ kPa}}{1 \text{ kN/m}^2} \right) \\ &= \mathbf{354.6 \text{ kPa}} \end{aligned}$$

Therefore, the pressure in the gasoline pipe is 15.4 kPa lower than the pressure reading of the pressure gage.

Discussion Note that sometimes the use of specific gravity offers great convenience in the solution of problems that involve several fluids.

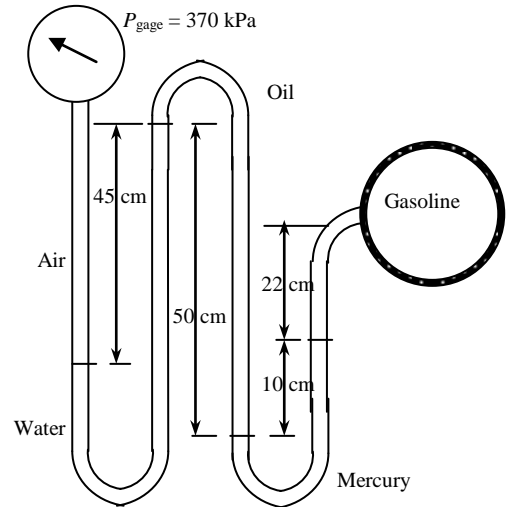

1-113 A gasoline line is connected to a pressure gage through a double-U manometer. For a given reading of the pressure gage, the gage pressure of the gasoline line is to be determined.

Assumptions 1 All the liquids are incompressible. **2** The effect of air column on pressure is negligible.

Properties The specific gravities of oil, mercury, and gasoline are given to be 0.79, 13.6, and 0.70, respectively. We take the density of water to be $\rho_w = 1000 \text{ kg/m}^3$.

Analysis Starting with the pressure indicated by the pressure gage and moving along the tube by adding (as we go down) or subtracting (as we go up) the ρgh terms until we reach the gasoline pipe, and setting the result equal to P_{gasoline} gives

$$P_{\text{gage}} - \rho_w gh_w + \rho_{\text{oil}} gh_{\text{oil}} - \rho_{\text{Hg}} gh_{\text{Hg}} - \rho_{\text{gasoline}} gh_{\text{gasoline}} = P_{\text{gasoline}}$$

Rearranging,

$$P_{\text{gasoline}} = P_{\text{gage}} - \rho_w g(h_w - SG_{\text{oil}}h_{\text{oil}} + SG_{\text{Hg}}h_{\text{Hg}} + SG_{\text{gasoline}}h_{\text{gasoline}})$$

Substituting,

$$\begin{aligned} P_{\text{gasoline}} &= 180 \text{ kPa} - (1000 \text{ kg/m}^3)(9.807 \text{ m/s}^2)[(0.45 \text{ m}) - 0.79(0.5 \text{ m}) + 13.6(0.1 \text{ m}) + 0.70(0.22 \text{ m})] \\ &\times \left(\frac{1 \text{ kN}}{1000 \text{ kg} \cdot \text{m/s}^2} \right) \left(\frac{1 \text{ kPa}}{1 \text{ kN/m}^2} \right) \\ &= \mathbf{164.6 \text{ kPa}} \end{aligned}$$

Therefore, the pressure in the gasoline pipe is 15.4 kPa lower than the pressure reading of the pressure gage.

Discussion Note that sometimes the use of specific gravity offers great convenience in the solution of problems that involve several fluids.

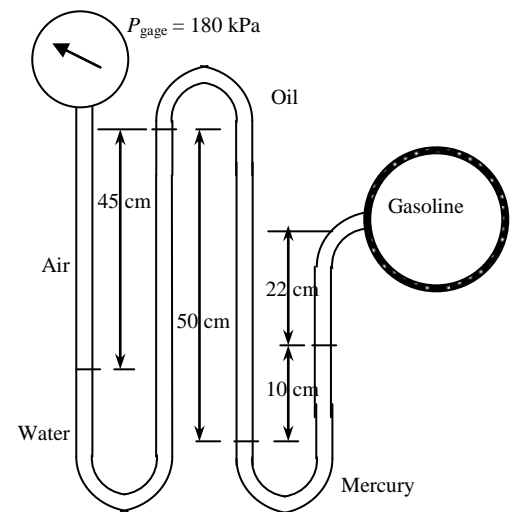

1-114 The average atmospheric pressure is given as $P_{\text{atm}} = 101.325(1 - 0.02256z)^{5.256}$ where z is the altitude in km. The atmospheric pressures at various locations are to be determined.

Analysis The atmospheric pressures at various locations are obtained by substituting the altitude z values in km into the relation

$$P_{\text{atm}} = 101.325(1 - 0.02256z)^{5.256}$$

Atlanta: $(z = 0.306 \text{ km}): P_{\text{atm}} = 101.325(1 - 0.02256 \times 0.306)^{5.256} = \mathbf{97.7 \text{ kPa}}$

Denver: $(z = 1.610 \text{ km}): P_{\text{atm}} = 101.325(1 - 0.02256 \times 1.610)^{5.256} = \mathbf{83.4 \text{ kPa}}$

M. City: $(z = 2.309 \text{ km}): P_{\text{atm}} = 101.325(1 - 0.02256 \times 2.309)^{5.256} = \mathbf{76.5 \text{ kPa}}$

Mt. Ev.: $(z = 8.848 \text{ km}): P_{\text{atm}} = 101.325(1 - 0.02256 \times 8.848)^{5.256} = \mathbf{31.4 \text{ kPa}}$

1-115 The temperature of the atmosphere varies with altitude z as $T = T_0 - \beta z$, while the gravitational acceleration varies by $g(z) = g_0 / (1 + z / 6,370,320)^2$. Relations for the variation of pressure in atmosphere are to be obtained (a) by ignoring and (b) by considering the variation of g with altitude.

Assumptions The air in the troposphere behaves as an ideal gas.

Analysis (a) Pressure change across a differential fluid layer of thickness dz in the vertical z direction is

$$dP = -\rho g dz$$

From the ideal gas relation, the air density can be expressed as $\rho = \frac{P}{RT} = \frac{P}{R(T_0 - \beta z)}$. Then,

$$dP = -\frac{P}{R(T_0 - \beta z)} g dz$$

Separating variables and integrating from $z = 0$ where $P = P_0$ to $z = z$ where $P = P$,

$$\int_{P_0}^P \frac{dP}{P} = -\int_0^z \frac{g dz}{R(T_0 - \beta z)}$$

Performing the integrations,

$$\ln \frac{P}{P_0} = \frac{g}{R\beta} \ln \frac{T_0 - \beta z}{T_0}$$

Rearranging, the desired relation for atmospheric pressure for the case of constant g becomes

$$P = P_0 \left(1 - \frac{\beta z}{T_0} \right)^{\frac{g}{R\beta}}$$

(b) When the variation of g with altitude is considered, the procedure remains the same but the expressions become more complicated,

$$dP = -\frac{P}{R(T_0 - \beta z)} \frac{g_0}{(1 + z / 6,370,320)^2} dz$$

Separating variables and integrating from $z = 0$ where $P = P_0$ to $z = z$ where $P = P$,

$$\int_{P_0}^P \frac{dP}{P} = -\int_0^z \frac{g_0 dz}{R(T_0 - \beta z)(1 + z / 6,370,320)^2}$$

Performing the integrations,

$$\ln P \Big|_{P_0}^P = \frac{g_0}{R\beta} \left[\frac{1}{(1 + kT_0 / \beta)(1 + kz)} - \frac{1}{(1 + kT_0 / \beta)^2} \ln \frac{1 + kz}{T_0 - \beta z} \right]_0^z$$

where $R = 287 \text{ J/kg}\cdot\text{K} = 287 \text{ m}^2/\text{s}^2\cdot\text{K}$ is the gas constant of air. After some manipulations, we obtain

$$P = P_0 \exp \left[-\frac{g_0}{R(\beta + kT_0)} \left(\frac{1}{1 + 1/kz} + \frac{1}{1 + kT_0 / \beta} \ln \frac{1 + kz}{1 - \beta z / T_0} \right) \right]$$

where $T_0 = 288.15 \text{ K}$, $\beta = 0.0065 \text{ K/m}$, $g_0 = 9.807 \text{ m/s}^2$, $k = 1/6,370,320 \text{ m}^{-1}$, and z is the elevation in m.

Discussion When performing the integration in part (b), the following expression from integral tables is used, together with a transformation of variable $x = T_0 - \beta z$,

$$\int \frac{dx}{x(a + bx)^2} = \frac{1}{a(a + bx)} - \frac{1}{a^2} \ln \frac{a + bx}{x}$$

Also, for $z = 11,000 \text{ m}$, for example, the relations in (a) and (b) give 22.62 and 22.69 kPa, respectively.

1-116 The variation of pressure with density in a thick gas layer is given. A relation is to be obtained for pressure as a function of elevation z .

Assumptions The property relation $P = C\rho^n$ is valid over the entire region considered.

Analysis The pressure change across a differential fluid layer of thickness dz in the vertical z direction is given as,

$$dP = -\rho g dz$$

Also, the relation $P = C\rho^n$ can be expressed as $C = P / \rho^n = P_0 / \rho_0^n$, and thus

$$\rho = \rho_0 (P / P_0)^{1/n}$$

Substituting,

$$dP = -g\rho_0 (P / P_0)^{1/n} dz$$

Separating variables and integrating from $z = 0$ where $P = P_0 = C\rho_0^n$ to $z = z$ where $P = P$,

$$\int_{P_0}^P (P / P_0)^{-1/n} dP = -\rho_0 g \int_0^z dz$$

Performing the integrations.

$$P_0 \frac{(P / P_0)^{-1/n+1}}{-1/n+1} \Big|_{P_0}^P = -\rho_0 g z \quad \rightarrow \quad \left(\frac{P}{P_0} \right)^{(n-1)/n} - 1 = -\frac{n-1}{n} \frac{\rho_0 g z}{P_0}$$

Solving for P ,

$$P = P_0 \left(1 - \frac{n-1}{n} \frac{\rho_0 g z}{P_0} \right)^{n/(n-1)}$$

which is the desired relation.

Discussion The final result could be expressed in various forms. The form given is very convenient for calculations as it facilitates unit cancellations and reduces the chance of error.

1-117 The flow of air through a wind turbine is considered. Based on unit considerations, a proportionality relation is to be obtained for the mass flow rate of air through the blades.

Assumptions Wind approaches the turbine blades with a uniform velocity.

Analysis The mass flow rate depends on the air density, average wind velocity, and the cross-sectional area which depends on hose diameter. Also, the unit of mass flow rate \dot{m} is kg/s. Therefore, the independent quantities should be arranged such that we end up with the proper unit. Putting the given information into perspective, we have

$$\dot{m} \text{ [kg/s]} \text{ is a function of } \rho \text{ [kg/m}^3\text{]}, D \text{ [m]}, \text{ and } V \text{ [m/s]}$$

It is obvious that the only way to end up with the unit “kg/s” for mass flow rate is to multiply the quantities ρ and V with the square of D . Therefore, the desired proportionality relation is

$$\dot{m} \text{ is proportional to } \rho D^2 V$$

or,

$$\dot{m} = C \rho D^2 V$$

where the constant of proportionality is $C = \pi/4$ so that $\dot{m} = \rho(\pi D^2 / 4)V$

Discussion Note that the dimensionless constants of proportionality cannot be determined with this approach.

1-118 A relation for the air drag exerted on a car is to be obtained in terms of on the drag coefficient, the air density, the car velocity, and the frontal area of the car.

Analysis The drag force depends on a dimensionless drag coefficient, the air density, the car velocity, and the frontal area. Also, the unit of force F is newton N, which is equivalent to $\text{kg}\cdot\text{m}/\text{s}^2$. Therefore, the independent quantities should be arranged such that we end up with the unit $\text{kg}\cdot\text{m}/\text{s}^2$ for the drag force. Putting the given information into perspective, we have

$$F_D \text{ [kg}\cdot\text{m/s}^2\text{]} \leftrightarrow C_{\text{Drag}} [], A_{\text{front}} \text{ [m}^2\text{]}, \rho \text{ [kg/m}^3\text{]}, \text{ and } V \text{ [m/s]}$$

It is obvious that the only way to end up with the unit “ $\text{kg}\cdot\text{m}/\text{s}^2$ ” for drag force is to multiply mass with the square of the velocity and the fontal area, with the drag coefficient serving as the constant of proportionality. Therefore, the desired relation is

$$F_D = C_{\text{Drag}} \rho A_{\text{front}} V^2$$

Discussion Note that this approach is not sensitive to dimensionless quantities, and thus a strong reasoning is required.

Fundamentals of Engineering (FE) Exam Problems

1-119 An apple loses 4.5 kJ of heat as it cools per °C drop in its temperature. The amount of heat loss from the apple per °F drop in its temperature is

- (a) 1.25 kJ (b) 2.50 kJ (c) 5.0 kJ (d) 8.1 kJ (e) 4.1 kJ

Answer (b) 2.50 kJ

Solution Solved by EES Software. Solutions can be verified by copying-and-pasting the following lines on a blank EES screen. (Similar problems and their solutions can be obtained easily by modifying numerical values).

Q_perC=4.5 "kJ"

Q_perF=Q_perC/1.8 "kJ"

"Some Wrong Solutions with Common Mistakes:"

W1_Q=Q_perC*1.8 "multiplying instead of dividing"

W2_Q=Q_perC "setting them equal to each other"

1-120 Consider a fish swimming 5 m below the free surface of water. The increase in the pressure exerted on the fish when it dives to a depth of 25 m below the free surface is

- (a) 196 Pa (b) 5400 Pa (c) 30,000 Pa (d) 196,000 Pa (e) 294,000 Pa

Answer (d) 196,000 Pa

Solution Solved by EES Software. Solutions can be verified by copying-and-pasting the following lines on a blank EES screen. (Similar problems and their solutions can be obtained easily by modifying numerical values).

rho=1000 "kg/m3"

g=9.81 "m/s2"

z1=5 "m"

z2=25 "m"

DELTAP=rho*g*(z2-z1) "Pa"

"Some Wrong Solutions with Common Mistakes:"

W1_P=rho*g*(z2-z1)/1000 "dividing by 1000"

W2_P=rho*g*(z1+z2) "adding depts instead of subtracting"

W3_P=rho*(z1+z2) "not using g"

W4_P=rho*g*(0+z2) "ignoring z1"

1-121 The atmospheric pressures at the top and the bottom of a building are read by a barometer to be 96.0 and 98.0 kPa. If the density of air is 1.0 kg/m^3 , the height of the building is

- (a) 17 m (b) 20 m (c) 170 m (d) 204 m (e) 252 m

Answer (d) 204 m

Solution Solved by EES Software. Solutions can be verified by copying-and-pasting the following lines on a blank EES screen. (Similar problems and their solutions can be obtained easily by modifying numerical values).

```
rho=1.0 "kg/m3"
g=9.81 "m/s2"
P1=96 "kPa"
P2=98 "kPa"
DELTAP=P2-P1 "kPa"
DELTAP=rho*g*h/1000 "kPa"
"Some Wrong Solutions with Common Mistakes:"
DELTAP=rho*W1_h/1000 "not using g"
DELTAP=g*W2_h/1000 "not using rho"
P2=rho*g*W3_h/1000 "ignoring P1"
P1=rho*g*W4_h/1000 "ignoring P2"
```

1-122 Consider a 2-m deep swimming pool. The pressure difference between the top and bottom of the pool is

- (a) 12.0 kPa (b) 19.6 kPa (c) 38.1 kPa (d) 50.8 kPa (e) 200 kPa

Answer (b) 19.6 kPa

Solution Solved by EES Software. Solutions can be verified by copying-and-pasting the following lines on a blank EES screen. (Similar problems and their solutions can be obtained easily by modifying numerical values).

```
rho=1000 "kg/m^3"
g=9.81 "m/s2"
z1=0 "m"
z2=2 "m"
DELTAP=rho*g*(z2-z1)/1000 "kPa"
"Some Wrong Solutions with Common Mistakes:"
W1_P=rho*(z1+z2)/1000 "not using g"
W2_P=rho*g*(z2-z1)/2000 "taking half of z"
W3_P=rho*g*(z2-z1) "not dividing by 1000"
```

1-123 During a heating process, the temperature of an object rises by 10°C . This temperature rise is equivalent to a temperature rise of

- (a) 10°F (b) 42°F (c) 18 K (d) 18 R (e) 283 K

Answer (d) 18 R

Solution Solved by EES Software. Solutions can be verified by copying-and-pasting the following lines on a blank EES screen. (Similar problems and their solutions can be obtained easily by modifying numerical values).

```
T_inC=10 "C"
T_inR=T_inC*1.8 "R"
"Some Wrong Solutions with Common Mistakes:"
W1_TinF=T_inC "F, setting C and F equal to each other"
W2_TinF=T_inC*1.8+32 "F, converting to F"
W3_TinK=1.8*T_inC "K, wrong conversion from C to K"
W4_TinK=T_inC+273 "K, converting to K"
```

1-124 At sea level, the weight of 1 kg mass in SI units is 9.81 N. The weight of 1 lbm mass in English units is

- (a) 1 lbf (b) 9.81 lbf (c) 32.2 lbf (d) 0.1 lbf (e) 0.031 lbf

Answer (a) 1 lbf

Solution Solved by EES Software. Solutions can be verified by copying-and-pasting the following lines on a blank EES screen. (Similar problems and their solutions can be obtained easily by modifying numerical values).

```
m=1 "lbm"
g=32.2 "ft/s2"
W=m*g/32.2 "lbf"
"Some Wrong Solutions with Common Mistakes:"
gSI=9.81 "m/s2"
W1_W= m*gSI "Using wrong conversion"
W2_W= m*g "Using wrong conversion"
W3_W= m/gSI "Using wrong conversion"
W4_W= m/g "Using wrong conversion"
```

1-125, 1-126 Design and Essay Problems



Solutions Manual for
Thermodynamics: An Engineering Approach
8th Edition
Yunus A. Cengel, Michael A. Boles
McGraw-Hill, 2015

Chapter 2
ENERGY, ENERGY TRANSFER, AND
GENERAL ENERGY ANALYSIS

PROPRIETARY AND CONFIDENTIAL

This Manual is the proprietary property of McGraw-Hill Education and protected by copyright and other state and federal laws. By opening and using this Manual the user agrees to the following restrictions, and if the recipient does not agree to these restrictions, the Manual should be promptly returned unopened to McGraw-Hill Education: **This Manual is being provided only to authorized professors and instructors for use in preparing for the classes using the affiliated textbook. No other use or distribution of this Manual is permitted. This Manual may not be sold and may not be distributed to or used by any student or other third party. No part of this Manual may be reproduced, displayed or distributed in any form or by any means, electronic or otherwise, without the prior written permission of McGraw-Hill Education.**

Forms of Energy

2-1C The sum of all forms of the energy a system possesses is called *total energy*. In the absence of magnetic, electrical and surface tension effects, the total energy of a system consists of the kinetic, potential, and internal energies.

2-2C The internal energy of a system is made up of sensible, latent, chemical and nuclear energies. The sensible internal energy is due to translational, rotational, and vibrational effects.

2-3C Thermal energy is the sensible and latent forms of internal energy, and it is referred to as heat in daily life.

2-4C The *mechanical energy* is the form of energy that can be converted to mechanical work completely and directly by a mechanical device such as a propeller. It differs from thermal energy in that thermal energy cannot be converted to work directly and completely. The forms of mechanical energy of a fluid stream are kinetic, potential, and flow energies.

2-5C Hydrogen is also a fuel, since it can be burned, but it is not an energy source since there are no hydrogen reserves in the world. Hydrogen can be obtained from water by using another energy source, such as solar or nuclear energy, and then the hydrogen obtained can be used as a fuel to power cars or generators. Therefore, it is more proper to view hydrogen is an energy carrier than an energy source.

2-6C In electric heaters, electrical energy is converted to sensible internal energy.

2-7C The forms of energy involved are electrical energy and sensible internal energy. Electrical energy is converted to sensible internal energy, which is transferred to the water as heat.

2-8E The total kinetic energy of an object is given is to be determined.

Analysis The total kinetic energy of the object is given by

$$KE = m \frac{V^2}{2} = (10 \text{ lbm}) \frac{(50 \text{ ft/s})^2}{2} \left(\frac{1 \text{ Btu/lbm}}{25,037 \text{ ft}^2/\text{s}^2} \right) = 0.499 \text{ Btu} \cong \mathbf{0.50 \text{ Btu}}$$

2-9E The total potential energy of an object is to be determined.

Analysis Substituting the given data into the potential energy expression gives

$$PE = mgz = (200 \text{ lbm})(32.2 \text{ ft/s}^2)(10 \text{ ft}) \left(\frac{1 \text{ Btu/lbm}}{25,037 \text{ ft}^2/\text{s}^2} \right) = \mathbf{2.57 \text{ Btu}}$$

2-10 A person with his suitcase goes up to the 10th floor in an elevator. The part of the energy of the elevator stored in the suitcase is to be determined.

Assumptions 1 The vibrational effects in the elevator are negligible.

Analysis The energy stored in the suitcase is stored in the form of potential energy, which is mgz . Therefore,

$$\Delta E_{\text{suitcase}} = \Delta PE = mg\Delta z = (30 \text{ kg})(9.81 \text{ m/s}^2)(35 \text{ m}) \left(\frac{1 \text{ kJ/kg}}{1000 \text{ m}^2/\text{s}^2} \right) = \mathbf{10.3 \text{ kJ}}$$

Therefore, the suitcase on 10th floor has 10.3 kJ more energy compared to an identical suitcase on the lobby level.

Discussion Noting that 1 kWh = 3600 kJ, the energy transferred to the suitcase is $10.3/3600 = 0.0029$ kWh, which is very small.

2-11 A hydraulic turbine-generator is to generate electricity from the water of a large reservoir. The power generation potential is to be determined.

Assumptions 1 The elevation of the reservoir remains constant.

2 The mechanical energy of water at the turbine exit is negligible.

Analysis The total mechanical energy water in a reservoir possesses is equivalent to the potential energy of water at the free surface, and it can be converted to work entirely. Therefore, the power potential of water is its potential energy, which is gz per unit mass, and $\dot{m}gz$ for a given mass flow rate.

$$e_{\text{mech}} = pe = gz = (9.81 \text{ m/s}^2)(120 \text{ m}) \left(\frac{1 \text{ kJ/kg}}{1000 \text{ m}^2/\text{s}^2} \right) = 1.177 \text{ kJ/kg}$$

Then the power generation potential becomes

$$\dot{W}_{\text{max}} = \dot{E}_{\text{mech}} = \dot{m}e_{\text{mech}} = (2400 \text{ kg/s})(1.177 \text{ kJ/kg}) \left(\frac{1 \text{ kW}}{1 \text{ kJ/s}} \right) = \mathbf{2825 \text{ kW}}$$

Therefore, the reservoir has the potential to generate 2825 kW of power.

Discussion This problem can also be solved by considering a point at the turbine inlet, and using flow energy instead of potential energy. It would give the same result since the flow energy at the turbine inlet is equal to the potential energy at the free surface of the reservoir.

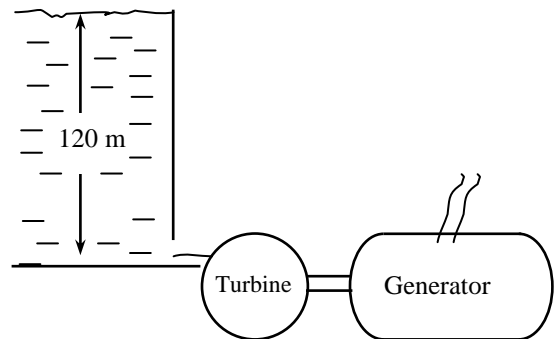

2-12 Wind is blowing steadily at a certain velocity. The mechanical energy of air per unit mass and the power generation potential are to be determined.

Assumptions The wind is blowing steadily at a constant uniform velocity.

Properties The density of air is given to be $\rho = 1.25 \text{ kg/m}^3$.

Analysis Kinetic energy is the only form of mechanical energy the wind possesses, and it can be converted to work entirely. Therefore, the power potential of the wind is its kinetic energy, which is $V^2/2$ per unit mass, and $\dot{m}V^2/2$ for a given mass flow rate:

$$e_{\text{mech}} = ke = \frac{V^2}{2} = \frac{(10 \text{ m/s})^2}{2} \left(\frac{1 \text{ kJ/kg}}{1000 \text{ m}^2/\text{s}^2} \right) = 0.050 \text{ kJ/kg}$$

$$\dot{m} = \rho VA = \rho V \frac{\pi D^2}{4} = (1.25 \text{ kg/m}^3)(10 \text{ m/s}) \frac{\pi (60 \text{ m})^2}{4} = 35,340 \text{ kg/s}$$

$$\dot{W}_{\text{max}} = \dot{E}_{\text{mech}} = \dot{m}e_{\text{mech}} = (35,340 \text{ kg/s})(0.050 \text{ kJ/kg}) = \mathbf{1770 \text{ kW}}$$

Therefore, 1770 kW of actual power can be generated by this wind turbine at the stated conditions.

Discussion The power generation of a wind turbine is proportional to the cube of the wind velocity, and thus the power generation will change strongly with the wind conditions.

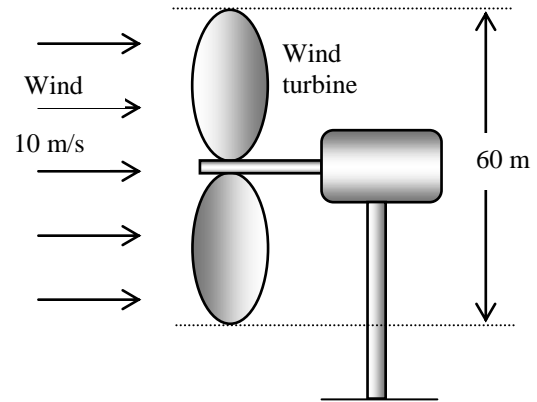

2-13 A water jet strikes the buckets located on the perimeter of a wheel at a specified velocity and flow rate. The power generation potential of this system is to be determined.

Assumptions Water jet flows steadily at the specified speed and flow rate.

Analysis Kinetic energy is the only form of harvestable mechanical energy the water jet possesses, and it can be converted to work entirely. Therefore, the power potential of the water jet is its kinetic energy, which is $V^2/2$ per unit mass, and $\dot{m}V^2/2$ for a given mass flow rate:

$$e_{\text{mech}} = ke = \frac{V^2}{2} = \frac{(60 \text{ m/s})^2}{2} \left(\frac{1 \text{ kJ/kg}}{1000 \text{ m}^2/\text{s}^2} \right) = 1.8 \text{ kJ/kg}$$

$$\begin{aligned} \dot{W}_{\text{max}} &= \dot{E}_{\text{mech}} = \dot{m}e_{\text{mech}} \\ &= (120 \text{ kg/s})(1.8 \text{ kJ/kg}) \left(\frac{1 \text{ kW}}{1 \text{ kJ/s}} \right) = \mathbf{216 \text{ kW}} \end{aligned}$$

Therefore, 216 kW of power can be generated by this water jet at the stated conditions.

Discussion An actual hydroelectric turbine (such as the Pelton wheel) can convert over 90% of this potential to actual electric power.

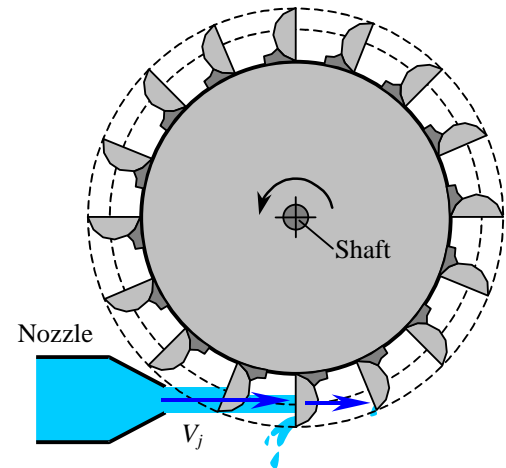

2-14 Two sites with specified wind data are being considered for wind power generation. The site better suited for wind power generation is to be determined.

Assumptions 1 The wind is blowing steadily at specified velocity during specified times. 2 The wind power generation is negligible during other times.

Properties We take the density of air to be $\rho = 1.25 \text{ kg/m}^3$ (it does not affect the final answer).

Analysis Kinetic energy is the only form of mechanical energy the wind possesses, and it can be converted to work entirely. Therefore, the power potential of the wind is its kinetic energy, which is $V^2/2$ per unit mass, and $\dot{m}V^2/2$ for a given mass flow rate. Considering a unit flow area ($A = 1 \text{ m}^2$), the maximum wind power and power generation becomes

$$e_{\text{mech},1} = ke_1 = \frac{V_1^2}{2} = \frac{(7 \text{ m/s})^2}{2} \left(\frac{1 \text{ kJ/kg}}{1000 \text{ m}^2/\text{s}^2} \right) = 0.0245 \text{ kJ/kg}$$

$$e_{\text{mech},2} = ke_2 = \frac{V_2^2}{2} = \frac{(10 \text{ m/s})^2}{2} \left(\frac{1 \text{ kJ/kg}}{1000 \text{ m}^2/\text{s}^2} \right) = 0.050 \text{ kJ/kg}$$

$$\dot{W}_{\text{max},1} = \dot{E}_{\text{mech},1} = \dot{m}_1 e_{\text{mech},1} = \rho V_1 A k e_1 = (1.25 \text{ kg/m}^3)(7 \text{ m/s})(1 \text{ m}^2)(0.0245 \text{ kJ/kg}) = 0.2144 \text{ kW}$$

$$\dot{W}_{\text{max},2} = \dot{E}_{\text{mech},2} = \dot{m}_2 e_{\text{mech},2} = \rho V_2 A k e_2 = (1.25 \text{ kg/m}^3)(10 \text{ m/s})(1 \text{ m}^2)(0.050 \text{ kJ/kg}) = 0.625 \text{ kW}$$

since $1 \text{ kW} = 1 \text{ kJ/s}$. Then the maximum electric power generations per year become

$$E_{\text{max},1} = \dot{W}_{\text{max},1} \Delta t_1 = (0.2144 \text{ kW})(3000 \text{ h/yr}) = \mathbf{643 \text{ kWh/yr}}$$
 (per m^2 flow area)

$$E_{\text{max},2} = \dot{W}_{\text{max},2} \Delta t_2 = (0.625 \text{ kW})(1500 \text{ h/yr}) = \mathbf{938 \text{ kWh/yr}}$$
 (per m^2 flow area)

Therefore, **second site** is a better one for wind generation.

Discussion Note the power generation of a wind turbine is proportional to the cube of the wind velocity, and thus the average wind velocity is the primary consideration in wind power generation decisions.

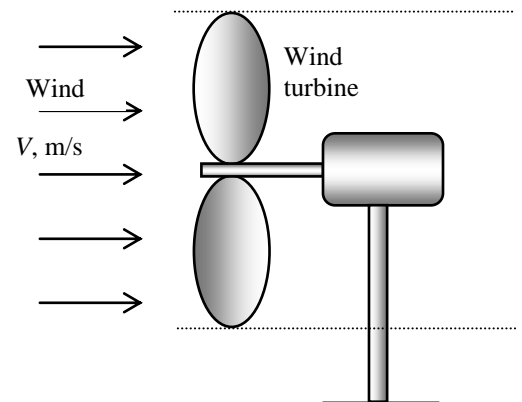

2-15 A river flowing steadily at a specified flow rate is considered for hydroelectric power generation by collecting the water in a dam. For a specified water height, the power generation potential is to be determined.

Assumptions 1 The elevation given is the elevation of the free surface of the river. **2** The mechanical energy of water at the turbine exit is negligible.

Properties We take the density of water to be $\rho = 1000 \text{ kg/m}^3$.

Analysis The total mechanical energy the water in a dam possesses is equivalent to the potential energy of water at the free surface of the dam (relative to free surface of discharge water), and it can be converted to work entirely. Therefore, the power potential of water is its potential energy, which is gz per unit mass, and $\dot{m}gz$ for a given mass flow rate.

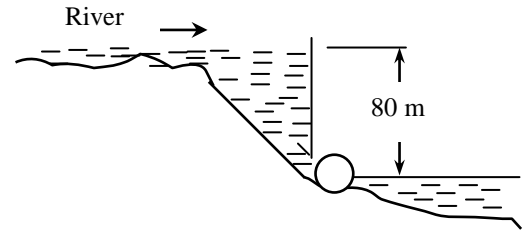

$$e_{\text{mech}} = pe = gz = (9.81 \text{ m/s}^2)(80 \text{ m}) \left(\frac{1 \text{ kJ/kg}}{1000 \text{ m}^2/\text{s}^2} \right) = 0.7848 \text{ kJ/kg}$$

The mass flow rate is

$$\dot{m} = \rho \dot{V} = (1000 \text{ kg/m}^3)(175 \text{ m}^3/\text{s}) = 175,000 \text{ kg/s}$$

Then the power generation potential becomes

$$\dot{W}_{\text{max}} = \dot{E}_{\text{mech}} = \dot{m}e_{\text{mech}} = (175,000 \text{ kg/s})(0.7848 \text{ kJ/kg}) \left(\frac{1 \text{ MW}}{1000 \text{ kJ/s}} \right) = \mathbf{137 \text{ MW}}$$

Therefore, 137 MW of power can be generated from this river if its power potential can be recovered completely.

Discussion Note that the power output of an actual turbine will be less than 137 MW because of losses and inefficiencies.

2-16 A river is flowing at a specified velocity, flow rate, and elevation. The total mechanical energy of the river water per unit mass, and the power generation potential of the entire river are to be determined.

Assumptions 1 The elevation given is the elevation of the free surface of the river. **2** The velocity given is the average velocity. **3** The mechanical energy of water at the turbine exit is negligible.

Properties We take the density of water to be $\rho = 1000 \text{ kg/m}^3$.

Analysis Noting that the sum of the flow energy and the potential energy is constant for a given fluid body, we can take the elevation of the entire river water to be the elevation of the free surface, and ignore the flow energy. Then the total mechanical energy of the river water per unit mass becomes

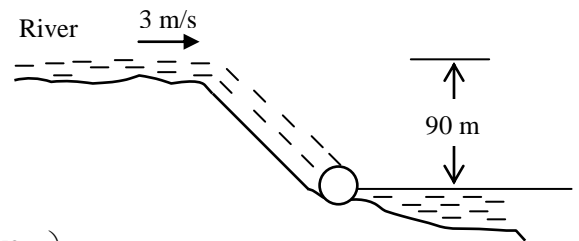

$$e_{\text{mech}} = pe + ke = gh + \frac{V^2}{2} = \left((9.81 \text{ m/s}^2)(90 \text{ m}) + \frac{(3 \text{ m/s})^2}{2} \right) \left(\frac{1 \text{ kJ/kg}}{1000 \text{ m}^2/\text{s}^2} \right) = \mathbf{0.887 \text{ kJ/kg}}$$

The power generation potential of the river water is obtained by multiplying the total mechanical energy by the mass flow rate,

$$\dot{m} = \rho \dot{V} = (1000 \text{ kg/m}^3)(500 \text{ m}^3/\text{s}) = 500,000 \text{ kg/s}$$

$$\dot{W}_{\text{max}} = \dot{E}_{\text{mech}} = \dot{m}e_{\text{mech}} = (500,000 \text{ kg/s})(0.887 \text{ kJ/kg}) = 444,000 \text{ kW} = \mathbf{444 \text{ MW}}$$

Therefore, 444 MW of power can be generated from this river as it discharges into the lake if its power potential can be recovered completely.

Discussion Note that the kinetic energy of water is negligible compared to the potential energy, and it can be ignored in the analysis. Also, the power output of an actual turbine will be less than 444 MW because of losses and inefficiencies.

Energy Transfer by Heat and Work

2-17C The form of energy that crosses the boundary of a closed system because of a temperature difference is heat; all other forms are work.

2-18C (a) The car's radiator transfers heat from the hot engine cooling fluid to the cooler air. No work interaction occurs in the radiator.

(b) The hot engine transfers heat to cooling fluid and ambient air while delivering work to the transmission.

(c) The warm tires transfer heat to the cooler air and to some degree to the cooler road while no work is produced. No work is produced since there is no motion of the forces acting at the interface between the tire and road.

(d) There is minor amount of heat transfer between the tires and road. Presuming that the tires are hotter than the road, the heat transfer is from the tires to the road. There is no work exchange associated with the road since it cannot move.

(e) Heat is being added to the atmospheric air by the hotter components of the car. Work is being done on the air as it passes over and through the car.

2-19C (a) From the perspective of the contents, heat must be removed in order to reduce and maintain the content's temperature. Heat is also being added to the contents from the room air since the room air is hotter than the contents.

(b) Considering the system formed by the refrigerator box when the doors are closed, there are three interactions, electrical work and two heat transfers. There is a transfer of heat from the room air to the refrigerator through its walls. There is also a transfer of heat from the hot portions of the refrigerator (i.e., back of the compressor where condenser is placed) system to the room air. Finally, electrical work is being added to the refrigerator through the refrigeration system.

(c) Heat is transferred through the walls of the room from the warm room air to the cold winter air. Electrical work is being done on the room through the electrical wiring leading into the room.

2-20C It is a work interaction.

2-21C It is a work interaction since the electrons are crossing the system boundary, thus doing electrical work.

2-22C It is a heat interaction since it is due to the temperature difference between the sun and the room.

2-23C This is neither a heat nor a work interaction since no energy is crossing the system boundary. This is simply the conversion of one form of internal energy (chemical energy) to another form (sensible energy).

2-24 The power produced by an electrical motor is to be expressed in different units.

Analysis Using appropriate conversion factors, we obtain

$$(a) \quad \dot{W} = (5 \text{ W}) \left(\frac{1 \text{ J/s}}{1 \text{ W}} \right) \left(\frac{1 \text{ N} \cdot \text{m}}{1 \text{ J}} \right) = \mathbf{5 \text{ N} \cdot \text{m/s}}$$

$$(b) \quad \dot{W} = (5 \text{ W}) \left(\frac{1 \text{ J/s}}{1 \text{ W}} \right) \left(\frac{1 \text{ N} \cdot \text{m}}{1 \text{ J}} \right) \left(\frac{1 \text{ kg} \cdot \text{m/s}^2}{1 \text{ N}} \right) = \mathbf{5 \text{ kg} \cdot \text{m}^2/\text{s}^3}$$

2-25E The power produced by a model aircraft engine is to be expressed in different units.

Analysis Using appropriate conversion factors, we obtain

$$(a) \quad \dot{W} = (10 \text{ W}) \left(\frac{1 \text{ Btu/s}}{1055.056 \text{ W}} \right) \left(\frac{778.169 \text{ lbf} \cdot \text{ft/s}}{1 \text{ Btu/s}} \right) = \mathbf{7.38 \text{ lbf} \cdot \text{ft/s}}$$

$$(b) \quad \dot{W} = (10 \text{ W}) \left(\frac{1 \text{ hp}}{745.7 \text{ W}} \right) = \mathbf{0.0134 \text{ hp}}$$

Mechanical Forms of Work

2-26C The work done is the same, but the power is different.

2-27E A construction crane lifting a concrete beam is considered. The amount of work is to be determined considering (a) the beam and (b) the crane as the system.

Analysis (a) The work is done on the beam and it is determined from

$$\begin{aligned} W &= mg\Delta z = (3 \times 2000 \text{ lbm})(32.174 \text{ ft/s}^2) \left(\frac{1 \text{ lbf}}{32.174 \text{ lbm} \cdot \text{ft/s}^2} \right) (24 \text{ ft}) \\ &= \mathbf{144,000 \text{ lbf} \cdot \text{ft}} \\ &= (144,000 \text{ lbf} \cdot \text{ft}) \left(\frac{1 \text{ Btu}}{778.169 \text{ lbf} \cdot \text{ft}} \right) = \mathbf{185 \text{ Btu}} \end{aligned}$$

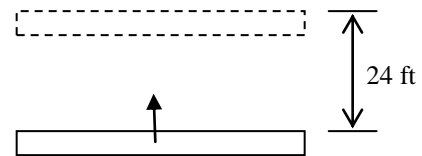

(b) Since the crane must produce the same amount of work as is required to lift the beam, the work done by the crane is

$$W = \mathbf{144,000 \text{ lbf} \cdot \text{ft} = 185 \text{ Btu}}$$

2-28E A man is pushing a cart with its contents up a ramp that is inclined at an angle of 10° from the horizontal. The work needed to move along this ramp is to be determined considering (a) the man and (b) the cart and its contents as the system.

Analysis (a) Considering the man as the system, letting l be the displacement along the ramp, and letting θ be the inclination angle of the ramp,

$$\begin{aligned} W &= Fl \sin \theta = (100 + 180 \text{ lbf})(100 \text{ ft})\sin(10) = \mathbf{4862 \text{ lbf} \cdot \text{ft}} \\ &= (4862 \text{ lbf} \cdot \text{ft}) \left(\frac{1 \text{ Btu}}{778.169 \text{ lbf} \cdot \text{ft}} \right) = \mathbf{6.248 \text{ Btu}} \end{aligned}$$

This is work that the man must do to raise the weight of the cart and contents, plus his own weight, a distance of $l \sin \theta$.

(b) Applying the same logic to the cart and its contents gives

$$\begin{aligned} W &= Fl \sin \theta = (100 \text{ lbf})(100 \text{ ft})\sin(10) = \mathbf{1736 \text{ lbf} \cdot \text{ft}} \\ &= (1736 \text{ lbf} \cdot \text{ft}) \left(\frac{1 \text{ Btu}}{778.169 \text{ lbf} \cdot \text{ft}} \right) = \mathbf{2.231 \text{ Btu}} \end{aligned}$$

2-29E The work required to compress a spring is to be determined.

Analysis Since there is no preload, $F = kx$. Substituting this into the work expression gives

$$\begin{aligned} W &= \int_1^2 F ds = \int_1^2 kx dx = k \int_1^2 x dx = \frac{k}{2} (x_2^2 - x_1^2) \\ &= \frac{200 \text{ lbf/in}}{2} [(1 \text{ in})^2 - 0^2] \left(\frac{1 \text{ ft}}{12 \text{ in}} \right) = \mathbf{8.33 \text{ lbf} \cdot \text{ft}} \\ &= (8.33 \text{ lbf} \cdot \text{ft}) \left(\frac{1 \text{ Btu}}{778.169 \text{ lbf} \cdot \text{ft}} \right) = \mathbf{0.0107 \text{ Btu}} \end{aligned}$$

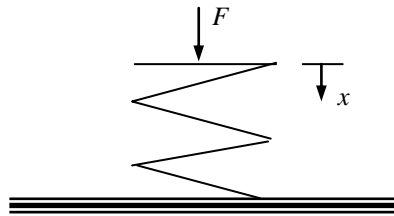

2-30 A car is accelerated from 10 to 60 km/h on an uphill road. The work needed to achieve this is to be determined.

Analysis The total work required is the sum of the changes in potential and kinetic energies,

$$W_a = \frac{1}{2} m (\mathbf{V}_2^2 - \mathbf{V}_1^2) = \frac{1}{2} (1300 \text{ kg}) \left(\left(\frac{60,000 \text{ m}}{3600 \text{ s}} \right)^2 - \left(\frac{10,000 \text{ m}}{3600 \text{ s}} \right)^2 \right) \left(\frac{1 \text{ kJ}}{1000 \text{ kg} \cdot \text{m}^2/\text{s}^2} \right) = 175.5 \text{ kJ}$$

and
$$W_g = mg(z_2 - z_1) = (1300 \text{ kg})(9.81 \text{ m/s}^2)(40 \text{ m}) \left(\frac{1 \text{ kJ}}{1000 \text{ kg} \cdot \text{m}^2/\text{s}^2} \right) = 510.0 \text{ kJ}$$

Thus,

$$W_{\text{total}} = W_a + W_g = 175.5 + 510.0 = \mathbf{686 \text{ kJ}}$$

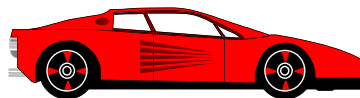

2-31E The engine of a car develops 450 hp at 3000 rpm. The torque transmitted through the shaft is to be determined.

Analysis The torque is determined from

$$T = \frac{\dot{W}_{sh}}{2\pi i} = \frac{450 \text{ hp}}{2\pi(3000/60)/s} \left(\frac{550 \text{ lbf} \cdot \text{ft/s}}{1 \text{ hp}} \right) = \mathbf{788 \text{ lbf} \cdot \text{ft}}$$

2-32E The work required to expand a soap bubble is to be determined.

Analysis Noting that there are two gas-liquid interfaces in a soap bubble, the surface tension work is determined from

$$\begin{aligned} W &= 2 \int_1^2 \sigma_s dA = \sigma(A_1 - A_2) = 2(0.005 \text{ lbf/ft}) \pi \left[(3/12 \text{ ft})^2 - (0.5/12 \text{ ft})^2 \right] \\ &= 0.001909 \text{ lbf} \cdot \text{ft} = (0.001909 \text{ lbf} \cdot \text{ft}) \left(\frac{1 \text{ Btu}}{778.2 \text{ lbf} \cdot \text{ft}} \right) = \mathbf{12.45 \times 10^{-6} \text{ Btu}} \end{aligned}$$

2-33 A linear spring is elongated by 20 cm from its rest position. The work done is to be determined.

Analysis The spring work can be determined from

$$W_{spring} = \frac{1}{2} k(x_2^2 - x_1^2) = \frac{1}{2} (70 \text{ kN/m})(0.2^2 - 0) \text{ m}^2 = 1.4 \text{ kN} \cdot \text{m} = \mathbf{1.4 \text{ kJ}}$$

2-34 A ski lift is operating steadily at 10 km/h. The power required to operate and also to accelerate this ski lift from rest to the operating speed are to be determined.

Assumptions **1** Air drag and friction are negligible. **2** The average mass of each loaded chair is 250 kg. **3** The mass of chairs is small relative to the mass of people, and thus the contribution of returning empty chairs to the motion is disregarded (this provides a safety factor).

Analysis The lift is 1000 m long and the chairs are spaced 20 m apart. Thus at any given time there are $1000/20 = 50$ chairs being lifted. Considering that the mass of each chair is 250 kg, the load of the lift at any given time is

$$\text{Load} = (50 \text{ chairs})(250 \text{ kg/chair}) = 12,500 \text{ kg}$$

Neglecting the work done on the system by the returning empty chairs, the work needed to raise this mass by 200 m is

$$W_g = mg(z_2 - z_1) = (12,500 \text{ kg})(9.81 \text{ m/s}^2)(200 \text{ m}) \left(\frac{1 \text{ kJ}}{1000 \text{ kg} \cdot \text{m}^2/\text{s}^2} \right) = 24,525 \text{ kJ}$$

At 10 km/h, it will take

$$\Delta t = \frac{\text{distance}}{\text{velocity}} = \frac{1 \text{ km}}{10 \text{ km/h}} = 0.1 \text{ h} = 360 \text{ s}$$

to do this work. Thus the power needed is

$$\dot{W}_g = \frac{W_g}{\Delta t} = \frac{24,525 \text{ kJ}}{360 \text{ s}} = \mathbf{68.1 \text{ kW}}$$

The velocity of the lift during steady operation, and the acceleration during start up are

$$V = (10 \text{ km/h}) \left(\frac{1 \text{ m/s}}{3.6 \text{ km/h}} \right) = 2.778 \text{ m/s}$$

$$a = \frac{\Delta V}{\Delta t} = \frac{2.778 \text{ m/s} - 0}{5 \text{ s}} = 0.556 \text{ m/s}^2$$

During acceleration, the power needed is

$$\dot{W}_a = \frac{1}{2} m(V_2^2 - V_1^2) / \Delta t = \frac{1}{2} (12,500 \text{ kg}) \left((2.778 \text{ m/s})^2 - 0 \right) \left(\frac{1 \text{ kJ/kg}}{1000 \text{ m}^2/\text{s}^2} \right) / (5 \text{ s}) = 9.6 \text{ kW}$$

Assuming the power applied is constant, the acceleration will also be constant and the vertical distance traveled during acceleration will be

$$h = \frac{1}{2} at^2 \sin \alpha = \frac{1}{2} at^2 \frac{200 \text{ m}}{1000 \text{ m}} = \frac{1}{2} (0.556 \text{ m/s}^2)(5 \text{ s})^2 (0.2) = 1.39 \text{ m}$$

and

$$\dot{W}_g = mg(z_2 - z_1) / \Delta t = (12,500 \text{ kg})(9.81 \text{ m/s}^2)(1.39 \text{ m}) \left(\frac{1 \text{ kJ/kg}}{1000 \text{ kg} \cdot \text{m}^2/\text{s}^2} \right) / (5 \text{ s}) = 34.1 \text{ kW}$$

Thus,

$$\dot{W}_{\text{total}} = \dot{W}_a + \dot{W}_g = 9.6 + 34.1 = \mathbf{43.7 \text{ kW}}$$

2-35 The engine of a car develops 75 kW of power. The acceleration time of this car from rest to 100 km/h on a level road is to be determined.

Analysis The work needed to accelerate a body is the change in its kinetic energy,

$$W_a = \frac{1}{2} m (V_2^2 - V_1^2) = \frac{1}{2} (1500 \text{ kg}) \left[\left(\frac{100,000 \text{ m}}{3600 \text{ s}} \right)^2 - 0 \right] \left(\frac{1 \text{ kJ}}{1000 \text{ kg} \cdot \text{m}^2/\text{s}^2} \right) = 578.7 \text{ kJ}$$

Thus the time required is

$$\Delta t = \frac{W_a}{\dot{W}_a} = \frac{578.7 \text{ kJ}}{75 \text{ kJ/s}} = 7.72 \text{ s}$$

This answer is not realistic because part of the power will be used against the air drag, friction, and rolling resistance.

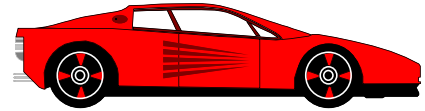

2-36 A car is to climb a hill in 12 s. The power needed is to be determined for three different cases.

Assumptions Air drag, friction, and rolling resistance are negligible.

Analysis The total power required for each case is the sum of the rates of changes in potential and kinetic energies. That is,

$$\dot{W}_{\text{total}} = \dot{W}_a + \dot{W}_g$$

(a) $\dot{W}_a = 0$ since the velocity is constant. Also, the vertical rise is $h = (100 \text{ m})(\sin 30^\circ) = 50 \text{ m}$. Thus,

$$\dot{W}_g = mg(z_2 - z_1) / \Delta t = (1150 \text{ kg})(9.81 \text{ m/s}^2)(50 \text{ m}) \left(\frac{1 \text{ kJ}}{1000 \text{ kg} \cdot \text{m}^2/\text{s}^2} \right) / (12 \text{ s}) = 47.0 \text{ kW}$$

and $\dot{W}_{\text{total}} = \dot{W}_a + \dot{W}_g = 0 + 47.0 = \mathbf{47.0 \text{ kW}}$

(b) The power needed to accelerate is

$$\dot{W}_a = \frac{1}{2} m (V_2^2 - V_1^2) / \Delta t = \frac{1}{2} (1150 \text{ kg}) \left[(30 \text{ m/s})^2 - 0 \right] \left(\frac{1 \text{ kJ}}{1000 \text{ kg} \cdot \text{m}^2/\text{s}^2} \right) / (12 \text{ s}) = 43.1 \text{ kW}$$

and $\dot{W}_{\text{total}} = \dot{W}_a + \dot{W}_g = 47.0 + 43.1 = \mathbf{90.1 \text{ kW}}$

(c) The power needed to decelerate is

$$\dot{W}_a = \frac{1}{2} m (V_2^2 - V_1^2) / \Delta t = \frac{1}{2} (1150 \text{ kg}) \left[(5 \text{ m/s})^2 - (35 \text{ m/s})^2 \right] \left(\frac{1 \text{ kJ}}{1000 \text{ kg} \cdot \text{m}^2/\text{s}^2} \right) / (12 \text{ s}) = -57.5 \text{ kW}$$

and $\dot{W}_{\text{total}} = \dot{W}_a + \dot{W}_g = -57.5 + 47.1 = \mathbf{-10.5 \text{ kW}}$ (braking power)

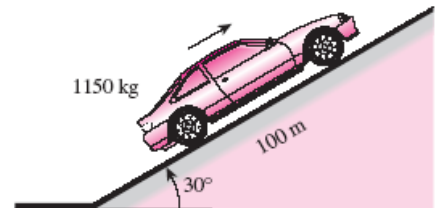

The First Law of Thermodynamics

2-37C Energy can be transferred to or from a control volume as heat, various forms of work, and by mass transport.

2-38C Warmer. Because energy is added to the room air in the form of electrical work.

2-39 Water is heated in a pan on top of a range while being stirred. The energy of the water at the end of the process is to be determined.

Assumptions The pan is stationary and thus the changes in kinetic and potential energies are negligible.

Analysis We take the water in the pan as our system. This is a closed system since no mass enters or leaves. Applying the energy balance on this system gives

$$\underbrace{E_{\text{in}} - E_{\text{out}}}_{\substack{\text{Net energy transfer} \\ \text{by heat, work, and mass}}} = \underbrace{\Delta E_{\text{system}}}_{\substack{\text{Change in internal, kinetic,} \\ \text{potential, etc. energies}}}$$

$$Q_{\text{in}} + W_{\text{sh,in}} - Q_{\text{out}} = \Delta U = U_2 - U_1$$

$$30 \text{ kJ} + 0.5 \text{ kJ} - 5 \text{ kJ} = U_2 - 10 \text{ kJ}$$

$$U_2 = \mathbf{35.5 \text{ kJ}}$$

Therefore, the final internal energy of the system is 35.5 kJ.

2-40E Water is heated in a cylinder on top of a range. The change in the energy of the water during this process is to be determined.

Assumptions The pan is stationary and thus the changes in kinetic and potential energies are negligible.

Analysis We take the water in the cylinder as the system. This is a closed system since no mass enters or leaves. Applying the energy balance on this system gives

$$\underbrace{E_{\text{in}} - E_{\text{out}}}_{\substack{\text{Net energy transfer} \\ \text{by heat, work, and mass}}} = \underbrace{\Delta E_{\text{system}}}_{\substack{\text{Change in internal, kinetic,} \\ \text{potential, etc. energies}}}$$

$$Q_{\text{in}} - W_{\text{out}} - Q_{\text{out}} = \Delta U = U_2 - U_1$$

$$65 \text{ Btu} - 5 \text{ Btu} - 8 \text{ Btu} = \Delta U$$

$$\Delta U = U_2 - U_1 = \mathbf{52 \text{ Btu}}$$

Therefore, the energy content of the system increases by 52 Btu during this process.

2-41E The heat loss from a house is to be made up by heat gain from people, lights, appliances, and resistance heaters. For a specified rate of heat loss, the required rated power of resistance heaters is to be determined.

Assumptions 1 The house is well-sealed, so no air enters or leaves the house. **2** All the lights and appliances are kept on. **3** The house temperature remains constant.

Analysis Taking the house as the system, the energy balance can be written as

$$\underbrace{\dot{E}_{\text{in}} - \dot{E}_{\text{out}}}_{\text{Rate of net energy transfer by heat, work, and mass}} = \underbrace{dE_{\text{system}}/dt}_{\text{Rate of change in internal, kinetic, potential, etc. energies}} \stackrel{\text{steady}}{\approx} 0 \rightarrow \dot{E}_{\text{in}} = \dot{E}_{\text{out}}$$

where $\dot{E}_{\text{out}} = \dot{Q}_{\text{out}} = 60,000 \text{ Btu/h}$ and

$$\dot{E}_{\text{in}} = \dot{E}_{\text{people}} + \dot{E}_{\text{lights}} + \dot{E}_{\text{appliance}} + \dot{E}_{\text{heater}} = 6000 \text{ Btu/h} + \dot{E}_{\text{heater}}$$

Substituting, the required power rating of the heaters becomes

$$\dot{E}_{\text{heater}} = 60,000 - 6000 = 54,000 \text{ Btu/h} \left(\frac{1 \text{ kW}}{3412 \text{ Btu/h}} \right) = \mathbf{15.8 \text{ kW}}$$

Discussion When the energy gain of the house equals the energy loss, the temperature of the house remains constant. But when the energy supplied drops below the heat loss, the house temperature starts dropping.

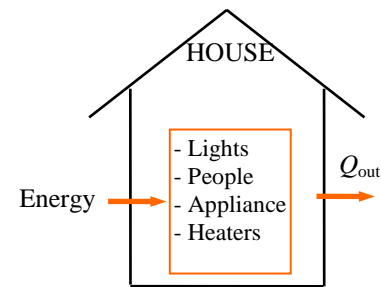

2-42E A water pump increases water pressure. The power input is to be determined.

Analysis The power input is determined from

$$\begin{aligned} \dot{W} &= \dot{V}(P_2 - P_1) \\ &= (0.8 \text{ ft}^3/\text{s})(70 - 15) \text{ psia} \left(\frac{1 \text{ Btu}}{5.404 \text{ psia} \cdot \text{ft}^3} \right) \left(\frac{1 \text{ hp}}{0.7068 \text{ Btu/s}} \right) \\ &= \mathbf{11.5 \text{ hp}} \end{aligned}$$

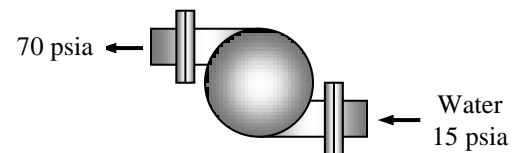

The water temperature at the inlet does not have any significant effect on the required power.

2-43 A water pump is claimed to raise water to a specified elevation at a specified rate while consuming electric power at a specified rate. The validity of this claim is to be investigated.

Assumptions 1 The water pump operates steadily. **2** Both the lake and the pool are open to the atmosphere, and the flow velocities in them are negligible.

Properties We take the density of water to be $\rho = 1000 \text{ kg/m}^3 = 1 \text{ kg/L}$.

Analysis For a control volume that encloses the pump-motor unit, the energy balance can be written as

$$\underbrace{\dot{E}_{in} - \dot{E}_{out}}_{\text{Rate of net energy transfer by heat, work, and mass}} = \underbrace{\frac{dE_{\text{system}}}{dt}}_{\text{Rate of change in internal, kinetic, potential, etc. energies}} \stackrel{\text{steady}}{\neq} 0 = 0$$

$$\dot{E}_{in} = \dot{E}_{out}$$

$$\dot{W}_{in} + \dot{m}pe_1 = \dot{m}pe_2 \rightarrow \dot{W}_{in} = \dot{m}\Delta pe = \dot{m}g(z_2 - z_1)$$

since the changes in kinetic and flow energies of water are negligible. Also,

$$\dot{m} = \rho\dot{V} = (1 \text{ kg/L})(50 \text{ L/s}) = 50 \text{ kg/s}$$

Substituting, the minimum power input required is determined to be

$$\dot{W}_{in} = \dot{m}g(z_2 - z_1) = (50 \text{ kg/s})(9.81 \text{ m/s}^2)(30 \text{ m}) \left(\frac{1 \text{ kJ/kg}}{1000 \text{ m}^2/\text{s}^2} \right) = 14.7 \text{ kJ/s} = \mathbf{14.7 \text{ kW}}$$

which is much greater than 2 kW. Therefore, the claim is **false**.

Discussion The conservation of energy principle requires the energy to be conserved as it is converted from one form to another, and it does not allow any energy to be created or destroyed during a process. In reality, the power required will be considerably higher than 14.7 kW because of the losses associated with the conversion of electrical-to-mechanical shaft and mechanical shaft-to-potential energy of water.

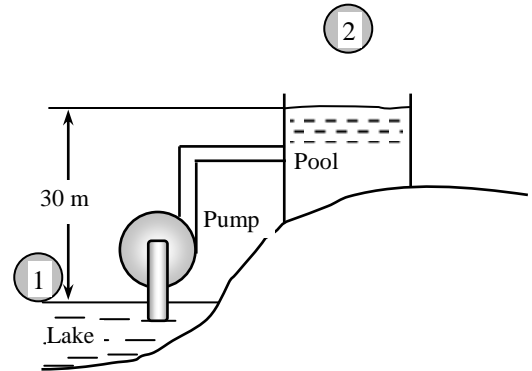

2-44 A classroom is to be air-conditioned using window air-conditioning units. The cooling load is due to people, lights, and heat transfer through the walls and the windows. The number of 5-kW window air conditioning units required is to be determined.

Assumptions There are no heat dissipating equipment (such as computers, TVs, or ranges) in the room.

Analysis The total cooling load of the room is determined from

$$\dot{Q}_{\text{cooling}} = \dot{Q}_{\text{lights}} + \dot{Q}_{\text{people}} + \dot{Q}_{\text{heat gain}}$$

where

$$\dot{Q}_{\text{lights}} = 10 \times 100 \text{ W} = 1 \text{ kW}$$

$$\dot{Q}_{\text{people}} = 40 \times 360 \text{ kJ/h} = 4 \text{ kW}$$

$$\dot{Q}_{\text{heat gain}} = 15,000 \text{ kJ/h} = 4.17 \text{ kW}$$

Substituting, $\dot{Q}_{\text{cooling}} = 1 + 4 + 4.17 = 9.17 \text{ kW}$

Thus the number of air-conditioning units required is

$$\frac{9.17 \text{ kW}}{5 \text{ kW/unit}} = 1.83 \rightarrow \mathbf{2 \text{ units}}$$

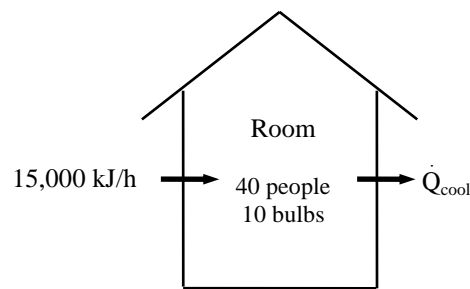

2-45 The classrooms and faculty offices of a university campus are not occupied an average of 4 hours a day, but the lights are kept on. The amounts of electricity and money the campus will save per year if the lights are turned off during unoccupied periods are to be determined.

Analysis The total electric power consumed by the lights in the classrooms and faculty offices is

$$\dot{E}_{\text{lighting,classroom}} = (\text{Power consumed per lamp}) \times (\text{No. of lamps}) = (200 \times 12 \times 110 \text{ W}) = 264,000 = 264 \text{ kW}$$

$$\dot{E}_{\text{lighting,offices}} = (\text{Power consumed per lamp}) \times (\text{No. of lamps}) = (400 \times 6 \times 110 \text{ W}) = 264,000 = 264 \text{ kW}$$

$$\dot{E}_{\text{lighting,total}} = \dot{E}_{\text{lighting,classroom}} + \dot{E}_{\text{lighting,offices}} = 264 + 264 = 528 \text{ kW}$$

Noting that the campus is open 240 days a year, the total number of unoccupied work hours per year is

$$\text{Unoccupied hours} = (4 \text{ hours/day})(240 \text{ days/year}) = 960 \text{ h/yr}$$

Then the amount of electrical energy consumed per year during unoccupied work period and its cost are

$$\text{Energy savings} = (\dot{E}_{\text{lighting,total}})(\text{Unoccupied hours}) = (528 \text{ kW})(960 \text{ h/yr}) = 506,880 \text{ kWh}$$

$$\text{Cost savings} = (\text{Energy savings})(\text{Unit cost of energy}) = (506,880 \text{ kWh/yr})(\$0.11/\text{kWh}) = \mathbf{\$55,757/\text{yr}}$$

Discussion Note that simple conservation measures can result in significant energy and cost savings.

2-46 An industrial facility is to replace its 40-W standard fluorescent lamps by their 35-W high efficiency counterparts. The amount of energy and money that will be saved a year as well as the simple payback period are to be determined.

Analysis The reduction in the total electric power consumed by the lighting as a result of switching to the high efficiency fluorescent is

$$\begin{aligned} \text{Wattage reduction} &= (\text{Wattage reduction per lamp})(\text{Number of lamps}) \\ &= (40 - 34 \text{ W/lamp})(700 \text{ lamps}) \\ &= 4200 \text{ W} \end{aligned}$$

Then using the relations given earlier, the energy and cost savings associated with the replacement of the high efficiency fluorescent lamps are determined to be

$$\begin{aligned} \text{Energy Savings} &= (\text{Total wattage reduction})(\text{Ballast factor})(\text{Operating hours}) \\ &= (4.2 \text{ kW})(1.1)(2800 \text{ h/year}) \\ &= \mathbf{12,936 \text{ kWh/year}} \end{aligned}$$

$$\begin{aligned} \text{Cost Savings} &= (\text{Energy savings})(\text{Unit electricity cost}) \\ &= (12,936 \text{ kWh/year})(\$0.105/\text{kWh}) \\ &= \mathbf{\$1358/\text{year}} \end{aligned}$$

The implementation cost of this measure is simply the extra cost of the energy efficient fluorescent bulbs relative to standard ones, and is determined to be

$$\begin{aligned} \text{Implementation Cost} &= (\text{Cost difference of lamps})(\text{Number of lamps}) \\ &= [(\$2.26 - \$1.77)/\text{lamp}](700 \text{ lamps}) \\ &= \$343 \end{aligned}$$

This gives a simple payback period of

$$\text{Simple payback period} = \frac{\text{Implementation cost}}{\text{Annual cost savings}} = \frac{\$343}{\$1358/\text{year}} = \mathbf{0.25 \text{ year}} \quad (3.0 \text{ months})$$

Discussion Note that if all the lamps were burned out today and are replaced by high-efficiency lamps instead of the conventional ones, the savings from electricity cost would pay for the cost differential in about 4 months. The electricity saved will also help the environment by reducing the amount of CO₂, CO, NO_x, etc. associated with the generation of electricity in a power plant.



2-47 A room contains a light bulb, a TV set, a refrigerator, and an iron. The rate of increase of the energy content of the room when all of these electric devices are on is to be determined.

Assumptions 1 The room is well sealed, and heat loss from the room is negligible. **2** All the appliances are kept on.

Analysis Taking the room as the system, the rate form of the energy balance can be written as

$$\underbrace{\dot{E}_{in} - \dot{E}_{out}}_{\text{Rate of net energy transfer by heat, work, and mass}} = \underbrace{dE_{\text{system}} / dt}_{\text{Rate of change in internal, kinetic, potential, etc. energies}} \rightarrow dE_{\text{room}} / dt = \dot{E}_{in}$$

since no energy is leaving the room in any form, and thus $\dot{E}_{out} = 0$. Also,

$$\begin{aligned} \dot{E}_{in} &= \dot{E}_{\text{lights}} + \dot{E}_{\text{TV}} + \dot{E}_{\text{refrig}} + \dot{E}_{\text{iron}} \\ &= 40 + 110 + 300 + 1200 \text{ W} \\ &= 1650 \text{ W} \end{aligned}$$

Substituting, the rate of increase in the energy content of the room becomes

$$dE_{\text{room}} / dt = \dot{E}_{in} = \mathbf{1650 \text{ W}}$$

Discussion Note that some appliances such as refrigerators and irons operate intermittently, switching on and off as controlled by a thermostat. Therefore, the rate of energy transfer to the room, in general, will be less.

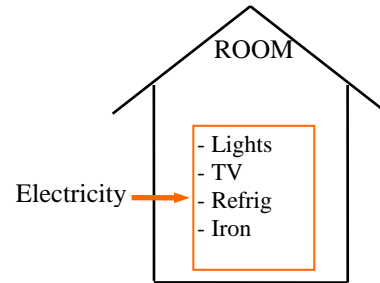

2-48E A fan accelerates air to a specified velocity in a square duct. The minimum electric power that must be supplied to the fan motor is to be determined.

Assumptions 1 The fan operates steadily. **2** There are no conversion losses.

Properties The density of air is given to be $\rho = 0.075 \text{ lbm/ft}^3$.

Analysis A fan motor converts electrical energy to mechanical shaft energy, and the fan transmits the mechanical energy of the shaft (shaft power) to mechanical energy of air (kinetic energy). For a control volume that encloses the fan-motor unit, the energy balance can be written as

$$\underbrace{\dot{E}_{in} - \dot{E}_{out}}_{\text{Rate of net energy transfer by heat, work, and mass}} = \underbrace{dE_{\text{system}} / dt}_{\text{Rate of change in internal, kinetic, potential, etc. energies}} \stackrel{\text{steady}}{=} 0 \rightarrow \dot{E}_{in} = \dot{E}_{out}$$

$$\dot{W}_{\text{elect, in}} = \dot{m}_{\text{air}} ke_{\text{out}} = \dot{m}_{\text{air}} \frac{V_{\text{out}}^2}{2}$$

where

$$\dot{m}_{\text{air}} = \rho VA = (0.075 \text{ lbm/ft}^3)(3 \times 3 \text{ ft}^2)(22 \text{ ft/s}) = 14.85 \text{ lbm/s}$$

Substituting, the minimum power input required is determined to be

$$\dot{W}_{in} = \dot{m}_{\text{air}} \frac{V_{\text{out}}^2}{2} = (14.85 \text{ lbm/s}) \frac{(22 \text{ ft/s})^2}{2} \left(\frac{1 \text{ Btu/lbm}}{25,037 \text{ ft}^2/\text{s}^2} \right) = 0.1435 \text{ Btu/s} = \mathbf{151 \text{ W}}$$

since $1 \text{ Btu} = 1.055 \text{ kJ}$ and $1 \text{ kJ/s} = 1000 \text{ W}$.

Discussion The conservation of energy principle requires the energy to be conserved as it is converted from one form to another, and it does not allow any energy to be created or destroyed during a process. In reality, the power required will be considerably higher because of the losses associated with the conversion of electrical-to-mechanical shaft and mechanical shaft-to-kinetic energy of air.

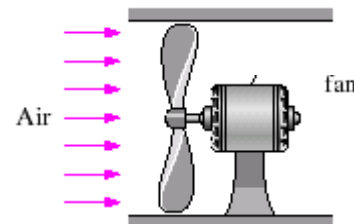

2-49 The fan of a central heating system circulates air through the ducts. For a specified pressure rise, the highest possible average flow velocity is to be determined.

Assumptions 1 The fan operates steadily. **2** The changes in kinetic and potential energies across the fan are negligible.

Analysis For a control volume that encloses the fan unit, the energy balance can be written as

$$\underbrace{\dot{E}_{in} - \dot{E}_{out}}_{\substack{\text{Rate of net energy transfer} \\ \text{by heat, work, and mass}}} = \underbrace{dE_{system}/dt}_{\substack{\text{Rate of change in internal, kinetic,} \\ \text{potential, etc. energies}}} \stackrel{\phi^0 \text{ (steady)}}{=} 0 \rightarrow \dot{E}_{in} = \dot{E}_{out}$$

$$\dot{W}_{in} + \dot{m}(Pv)_1 = \dot{m}(Pv)_2 \rightarrow \dot{W}_{in} = \dot{m}(P_2 - P_1)v = \dot{V} \Delta P$$

since $\dot{m} = \dot{V}/v$ and the changes in kinetic and potential energies of gasoline are negligible, Solving for volume flow rate and substituting, the maximum flow rate and velocity are determined to be

$$\dot{V}_{max} = \frac{\dot{W}_{in}}{\Delta P} = \frac{60 \text{ J/s}}{50 \text{ Pa}} \left(\frac{1 \text{ Pa} \cdot \text{m}^3}{1 \text{ J}} \right) = 1.2 \text{ m}^3/\text{s}$$

$$V_{max} = \frac{\dot{V}_{max}}{A_c} = \frac{\dot{V}_{max}}{\pi D^2 / 4} = \frac{1.2 \text{ m}^3/\text{s}}{\pi (0.30 \text{ m})^2 / 4} = \mathbf{17.0 \text{ m/s}}$$

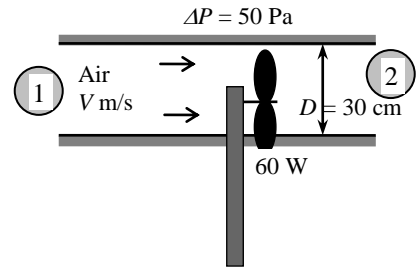

Discussion The conservation of energy principle requires the energy to be conserved as it is converted from one form to another, and it does not allow any energy to be created or destroyed during a process. In reality, the velocity will be less because of the losses associated with the conversion of electrical-to-mechanical shaft and mechanical shaft-to-flow energy.



2-50 A gasoline pump raises the pressure to a specified value while consuming electric power at a specified rate. The maximum volume flow rate of gasoline is to be determined.

Assumptions 1 The gasoline pump operates steadily. **2** The changes in kinetic and potential energies across the pump are negligible.

Analysis For a control volume that encloses the pump-motor unit, the energy balance can be written as

$$\underbrace{\dot{E}_{in} - \dot{E}_{out}}_{\substack{\text{Rate of net energy transfer} \\ \text{by heat, work, and mass}}} = \underbrace{dE_{system}/dt}_{\substack{\text{Rate of change in internal, kinetic,} \\ \text{potential, etc. energies}}} \stackrel{\phi^0 \text{ (steady)}}{=} 0 \rightarrow \dot{E}_{in} = \dot{E}_{out}$$

$$\dot{W}_{in} + \dot{m}(Pv)_1 = \dot{m}(Pv)_2 \rightarrow \dot{W}_{in} = \dot{m}(P_2 - P_1)v = \dot{V} \Delta P$$

since $\dot{m} = \dot{V}/v$ and the changes in kinetic and potential energies of gasoline are negligible, Solving for volume flow rate and substituting, the maximum flow rate is determined to be

$$\dot{V}_{max} = \frac{\dot{W}_{in}}{\Delta P} = \frac{3.8 \text{ kJ/s}}{7 \text{ kPa}} \left(\frac{1 \text{ kPa} \cdot \text{m}^3}{1 \text{ kJ}} \right) = \mathbf{0.543 \text{ m}^3/\text{s}}$$

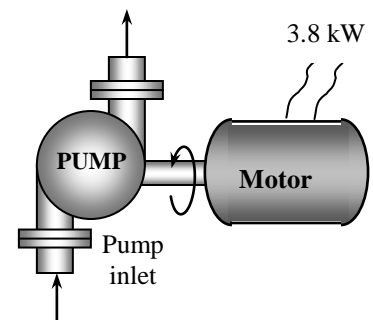

Discussion The conservation of energy principle requires the energy to be conserved as it is converted from one form to another, and it does not allow any energy to be created or destroyed during a process. In reality, the volume flow rate will be less because of the losses associated with the conversion of electrical-to-mechanical shaft and mechanical shaft-to-flow energy.

2-51 An inclined escalator is to move a certain number of people upstairs at a constant velocity. The minimum power required to drive this escalator is to be determined.

Assumptions **1** Air drag and friction are negligible. **2** The average mass of each person is 75 kg. **3** The escalator operates steadily, with no acceleration or braking. **4** The mass of escalator itself is negligible.

Analysis At design conditions, the total mass moved by the escalator at any given time is

$$\text{Mass} = (50 \text{ persons})(75 \text{ kg/person}) = 3750 \text{ kg}$$

The vertical component of escalator velocity is

$$V_{\text{vert}} = V \sin 45^\circ = (0.6 \text{ m/s})\sin 45^\circ$$

Under stated assumptions, the power supplied is used to increase the potential energy of people. Taking the people on elevator as the closed system, the energy balance in the rate form can be written as

$$\underbrace{\dot{E}_{\text{in}} - \dot{E}_{\text{out}}}_{\substack{\text{Rate of net energy transfer} \\ \text{by heat, work, and mass}}} = \underbrace{dE_{\text{system}}/dt}_{\substack{\text{Rate of change in internal, kinetic,} \\ \text{potential, etc. energies}}} = 0 \rightarrow \dot{E}_{\text{in}} = dE_{\text{sys}}/dt \cong \frac{\Delta E_{\text{sys}}}{\Delta t}$$

$$\dot{W}_{\text{in}} = \frac{\Delta PE}{\Delta t} = \frac{mg\Delta z}{\Delta t} = mgV_{\text{vert}}$$

That is, under stated assumptions, the power input to the escalator must be equal to the rate of increase of the potential energy of people. Substituting, the required power input becomes

$$\dot{W}_{\text{in}} = mgV_{\text{vert}} = (3750 \text{ kg})(9.81 \text{ m/s}^2)(0.6 \text{ m/s})\sin 45^\circ \left(\frac{1 \text{ kJ/kg}}{1000 \text{ m}^2/\text{s}^2} \right) = 12.5 \text{ kJ/s} = \mathbf{15.6 \text{ kW}}$$

When the escalator velocity is doubled to $V = 1.2 \text{ m/s}$, the power needed to drive the escalator becomes

$$\dot{W}_{\text{in}} = mgV_{\text{vert}} = (3750 \text{ kg})(9.81 \text{ m/s}^2)(1.2 \text{ m/s})\sin 45^\circ \left(\frac{1 \text{ kJ/kg}}{1000 \text{ m}^2/\text{s}^2} \right) = 25.0 \text{ kJ/s} = \mathbf{31.2 \text{ kW}}$$

Discussion Note that the power needed to drive an escalator is proportional to the escalator velocity.

2-52 A car cruising at a constant speed to accelerate to a specified speed within a specified time. The additional power needed to achieve this acceleration is to be determined.

Assumptions 1 The additional air drag, friction, and rolling resistance are not considered. **2** The road is a level road.

Analysis We consider the entire car as the system, except that let's assume the power is supplied to the engine externally for simplicity (rather than internally by the combustion of a fuel and the associated energy conversion processes). The energy balance for the entire mass of the car can be written in the rate form as

$$\underbrace{\dot{E}_{\text{in}} - \dot{E}_{\text{out}}}_{\substack{\text{Rate of net energy transfer} \\ \text{by heat, work, and mass}}} = \underbrace{dE_{\text{system}}/dt}_{\substack{\text{Rate of change in internal, kinetic,} \\ \text{potential, etc. energies}}} = 0 \rightarrow \dot{E}_{\text{in}} = dE_{\text{sys}}/dt \cong \frac{\Delta E_{\text{sys}}}{\Delta t}$$

$$\dot{W}_{\text{in}} = \frac{\Delta KE}{\Delta t} = \frac{m(V_2^2 - V_1^2)/2}{\Delta t}$$

since we are considering the change in the energy content of the car due to a change in its kinetic energy (acceleration). Substituting, the required additional power input to achieve the indicated acceleration becomes



$$\dot{W}_{\text{in}} = m \frac{V_2^2 - V_1^2}{2\Delta t} = (1400 \text{ kg}) \frac{(110/3.6 \text{ m/s})^2 - (70/3.6 \text{ m/s})^2}{2(5 \text{ s})} \left(\frac{1 \text{ kJ/kg}}{1000 \text{ m}^2/\text{s}^2} \right) = 77.8 \text{ kJ/s} = \mathbf{77.8 \text{ kW}}$$

since 1 m/s = 3.6 km/h. If the total mass of the car were 700 kg only, the power needed would be

$$\dot{W}_{\text{in}} = m \frac{V_2^2 - V_1^2}{2\Delta t} = (700 \text{ kg}) \frac{(110/3.6 \text{ m/s})^2 - (70/3.6 \text{ m/s})^2}{2(5 \text{ s})} \left(\frac{1 \text{ kJ/kg}}{1000 \text{ m}^2/\text{s}^2} \right) = \mathbf{38.9 \text{ kW}}$$

Discussion Note that the power needed to accelerate a car is inversely proportional to the acceleration time. Therefore, the short acceleration times are indicative of powerful engines.

Energy Conversion Efficiencies

2-53C The *combined pump-motor efficiency* of a pump/motor system is defined as the ratio of the increase in the mechanical energy of the fluid to the electrical power consumption of the motor,

$$\eta_{\text{pump-motor}} = \eta_{\text{pump}} \eta_{\text{motor}} = \frac{\dot{E}_{\text{mech,out}} - \dot{E}_{\text{mech,in}}}{\dot{W}_{\text{elect,in}}} = \frac{\Delta \dot{E}_{\text{mech,fluid}}}{\dot{W}_{\text{elect,in}}} = \frac{\dot{W}_{\text{pump}}}{\dot{W}_{\text{elect,in}}}$$

The combined pump-motor efficiency cannot be greater than either of the pump or motor efficiency since both pump and motor efficiencies are less than 1, and the product of two numbers that are less than one is less than either of the numbers.

2-54C The turbine efficiency, generator efficiency, and *combined turbine-generator efficiency* are defined as follows:

$$\eta_{\text{turbine}} = \frac{\text{Mechanical energy output}}{\text{Mechanical energy extracted from the fluid}} = \frac{\dot{W}_{\text{shaft,out}}}{|\Delta \dot{E}_{\text{mech,fluid}}|}$$

$$\eta_{\text{generator}} = \frac{\text{Electrical power output}}{\text{Mechanical power input}} = \frac{\dot{W}_{\text{elect,out}}}{\dot{W}_{\text{shaft,in}}}$$

$$\eta_{\text{turbine-gen}} = \eta_{\text{turbine}} \eta_{\text{generator}} = \frac{\dot{W}_{\text{elect,out}}}{\dot{E}_{\text{mech,in}} - \dot{E}_{\text{mech,out}}} = \frac{\dot{W}_{\text{elect,out}}}{|\Delta \dot{E}_{\text{mech,fluid}}|}$$

2-55C No, the combined pump-motor efficiency cannot be greater than either of the pump efficiency or the motor efficiency. This is because $\eta_{\text{pump-motor}} = \eta_{\text{pump}}\eta_{\text{motor}}$, and both η_{pump} and η_{motor} are less than one, and a number gets smaller when multiplied by a number smaller than one.

2-56 A hooded electric open burner and a gas burner are considered. The amount of the electrical energy used directly for cooking and the cost of energy per “utilized” kWh are to be determined.

Analysis The efficiency of the electric heater is given to be 73 percent. Therefore, a burner that consumes 3-kW of electrical energy will supply

$$\eta_{\text{gas}} = 38\%$$

$$\eta_{\text{electric}} = 73\%$$

$$\dot{Q}_{\text{utilized}} = (\text{Energy input}) \times (\text{Efficiency}) = (2.4 \text{ kW})(0.73) = \mathbf{1.75 \text{ kW}}$$

of useful energy. The unit cost of utilized energy is inversely proportional to the efficiency, and is determined from

$$\text{Cost of utilized energy} = \frac{\text{Cost of energy input}}{\text{Efficiency}} = \frac{\$0.10/\text{kWh}}{0.73} = \mathbf{\$0.137/\text{kWh}}$$

Noting that the efficiency of a gas burner is 38 percent, the energy input to a gas burner that supplies utilized energy at the same rate (1.75 kW) is

$$\dot{Q}_{\text{input,gas}} = \frac{\dot{Q}_{\text{utilized}}}{\text{Efficiency}} = \frac{1.75 \text{ kW}}{0.38} = \mathbf{4.61 \text{ kW}} \quad (= 15,700 \text{ Btu/h})$$

since 1 kW = 3412 Btu/h. Therefore, a gas burner should have a rating of at least 15,700 Btu/h to perform as well as the electric unit. Noting that 1 therm = 29.3 kWh, the unit cost of utilized energy in the case of gas burner is determined the same way to be

$$\text{Cost of utilized energy} = \frac{\text{Cost of energy input}}{\text{Efficiency}} = \frac{\$1.20/(29.3 \text{ kWh})}{0.38} = \mathbf{\$0.108/\text{kWh}}$$



2-57 A worn out standard motor is to be replaced by a high efficiency one. The amount of electrical energy and money savings as a result of installing the high efficiency motor instead of the standard one as well as the simple payback period are to be determined.

Assumptions The load factor of the motor remains constant at 0.75.

Analysis The electric power drawn by each motor and their difference can be expressed as

$$\begin{aligned}\dot{W}_{\text{electric in, standard}} &= \dot{W}_{\text{shaft}} / \eta_{\text{standard}} = (\text{Power rating})(\text{Load factor}) / \eta_{\text{standard}} \\ \dot{W}_{\text{electric in, efficient}} &= \dot{W}_{\text{shaft}} / \eta_{\text{efficient}} = (\text{Power rating})(\text{Load factor}) / \eta_{\text{efficient}} \\ \text{Power savings} &= \dot{W}_{\text{electric in, standard}} - \dot{W}_{\text{electric in, efficient}} \\ &= (\text{Power rating})(\text{Load factor})[1 / \eta_{\text{standard}} - 1 / \eta_{\text{efficient}}]\end{aligned}$$

where η_{standard} is the efficiency of the standard motor, and $\eta_{\text{efficient}}$ is the efficiency of the comparable high efficiency motor. Then the annual energy and cost savings associated with the installation of the high efficiency motor are determined to be

$$\begin{aligned}\text{Energy Savings} &= (\text{Power savings})(\text{Operating Hours}) \\ &= (\text{Power Rating})(\text{Operating Hours})(\text{Load Factor})(1/\eta_{\text{standard}} - 1/\eta_{\text{efficient}}) \\ &= (75 \text{ hp})(0.746 \text{ kW/hp})(4,368 \text{ hours/year})(0.75)(1/0.91 - 1/0.954) \\ &= \mathbf{9,290 \text{ kWh/year}}\end{aligned}$$

$$\begin{aligned}\text{Cost Savings} &= (\text{Energy savings})(\text{Unit cost of energy}) \\ &= (9,290 \text{ kWh/year})(\$0.12/\text{kWh}) \\ &= \mathbf{\$1114/\text{year}}\end{aligned}$$

The implementation cost of this measure consists of the excess cost the high efficiency motor over the standard one. That is,

$$\text{Implementation Cost} = \text{Cost differential} = \$5,520 - \$5,449 = \$71$$

This gives a simple payback period of

$$\text{Simple payback period} = \frac{\text{Implementation cost}}{\text{Annual cost savings}} = \frac{\$71}{\$1114/\text{year}} = \mathbf{0.0637 \text{ year}} \text{ (or 0.76 month)}$$

Therefore, the high-efficiency motor will pay for its cost differential in less than one month.

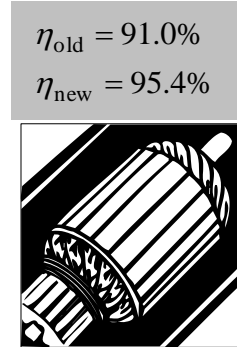

2-58 An electric motor with a specified efficiency operates in a room. The rate at which the motor dissipates heat to the room it is in when operating at full load and if this heat dissipation is adequate to heat the room in winter are to be determined.

Assumptions The motor operates at full load.

Analysis The motor efficiency represents the fraction of electrical energy consumed by the motor that is converted to mechanical work. The remaining part of electrical energy is converted to thermal energy and is dissipated as heat.

$$\dot{Q}_{\text{dissipated}} = (1 - \eta_{\text{motor}})\dot{W}_{\text{in, electric}} = (1 - 0.88)(20 \text{ kW}) = \mathbf{2.4 \text{ kW}}$$

which is larger than the rating of the heater. Therefore, the heat dissipated by the motor alone is sufficient to heat the room in winter, and there is no need to turn the heater on.

Discussion Note that the heat generated by electric motors is significant, and it should be considered in the determination of heating and cooling loads.

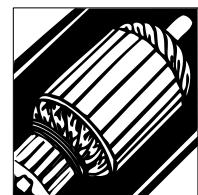

2-59E The combustion efficiency of a furnace is raised from 0.7 to 0.8 by tuning it up. The annual energy and cost savings as a result of tuning up the boiler are to be determined.

Assumptions The boiler operates at full load while operating.

Analysis The heat output of boiler is related to the fuel energy input to the boiler by

$$\text{Boiler output} = (\text{Boiler input})(\text{Combustion efficiency})$$

or
$$\dot{Q}_{\text{out}} = \dot{Q}_{\text{in}} \eta_{\text{furnace}}$$

The current rate of heat input to the boiler is given to be $\dot{Q}_{\text{in, current}} = 5.5 \times 10^6 \text{ Btu/h}$.

Then the rate of useful heat output of the boiler becomes

$$\dot{Q}_{\text{out}} = (\dot{Q}_{\text{in}} \eta_{\text{furnace}})_{\text{current}} = (5.5 \times 10^6 \text{ Btu/h})(0.7) = 3.85 \times 10^6 \text{ Btu/h}$$

The boiler must supply useful heat at the same rate after the tune up. Therefore, the rate of heat input to the boiler after the tune up and the rate of energy savings become

$$\dot{Q}_{\text{in, new}} = \dot{Q}_{\text{out}} / \eta_{\text{furnace, new}} = (3.85 \times 10^6 \text{ Btu/h}) / 0.8 = 4.81 \times 10^6 \text{ Btu/h}$$

$$\dot{Q}_{\text{in, saved}} = \dot{Q}_{\text{in, current}} - \dot{Q}_{\text{in, new}} = 5.5 \times 10^6 - 4.81 \times 10^6 = 0.69 \times 10^6 \text{ Btu/h}$$

Then the annual energy and cost savings associated with tuning up the boiler become

$$\begin{aligned} \text{Energy Savings} &= \dot{Q}_{\text{in, saved}} (\text{Operation hours}) \\ &= (0.69 \times 10^6 \text{ Btu/h})(4200 \text{ h/year}) = \mathbf{2.89 \times 10^9 \text{ Btu/yr}} \end{aligned}$$

$$\begin{aligned} \text{Cost Savings} &= (\text{Energy Savings})(\text{Unit cost of energy}) \\ &= (2.89 \times 10^9 \text{ Btu/yr})(\$4.35/10^6 \text{ Btu}) = \mathbf{\$12,600/\text{year}} \end{aligned}$$

Discussion Notice that tuning up the boiler will save \$12,600 a year, which is a significant amount. The implementation cost of this measure is negligible if the adjustment can be made by in-house personnel. Otherwise it is worthwhile to have an authorized representative of the boiler manufacturer to service the boiler twice a year.

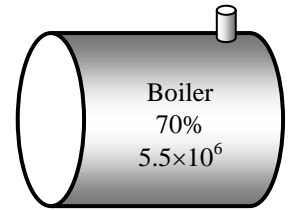



2-60E Problem 2-59E is reconsidered. The effects of the unit cost of energy and combustion efficiency on the annual energy used and the cost savings as the efficiency varies from 0.7 to 0.9 and the unit cost varies from \$4 to \$6 per million Btu are the investigated. The annual energy saved and the cost savings are to be plotted against the efficiency for unit costs of \$4, \$5, and \$6 per million Btu.

Analysis The problem is solved using EES, and the solution is given below.

"Given"

Q_dot_in_current=5.5E6 [Btu/h]
 eta_furnace_current=0.7
 eta_furnace_new=0.8
 Hours=4200 [h/year]
 UnitCost=4.35E-6 [\$/Btu]

"Analysis"

Q_dot_out=Q_dot_in_current*eta_furnace_current
 Q_dot_in_new=Q_dot_out/eta_furnace_new
 Q_dot_in_saved=Q_dot_in_current-Q_dot_in_new
 Energysavings=Q_dot_in_saved*Hours
 CostSavings=Energysavings*UnitCost

$\eta_{\text{furnace,new}}$	EnergySavings [Btu/year]	CostSavings [\$/year]
0.7	0.00E+00	0
0.72	6.42E+08	3208
0.74	1.25E+09	6243
0.76	1.82E+09	9118
0.78	2.37E+09	11846
0.8	2.89E+09	14437
0.82	3.38E+09	16902
0.84	3.85E+09	19250
0.86	4.30E+09	21488
0.88	4.73E+09	23625
0.9	5.13E+09	25667

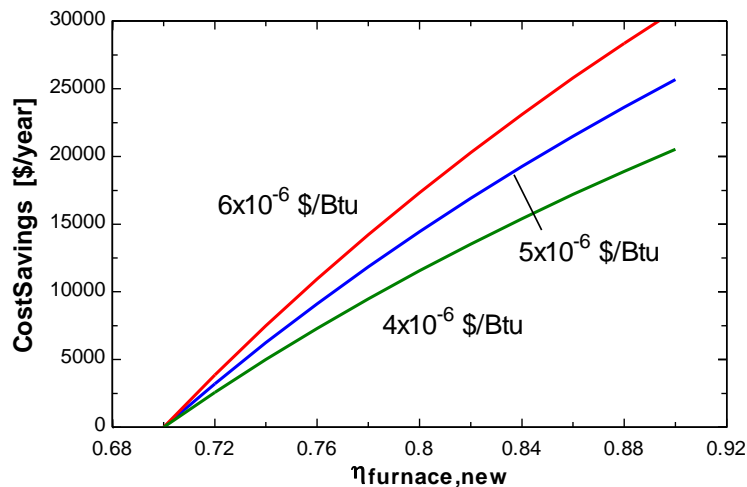
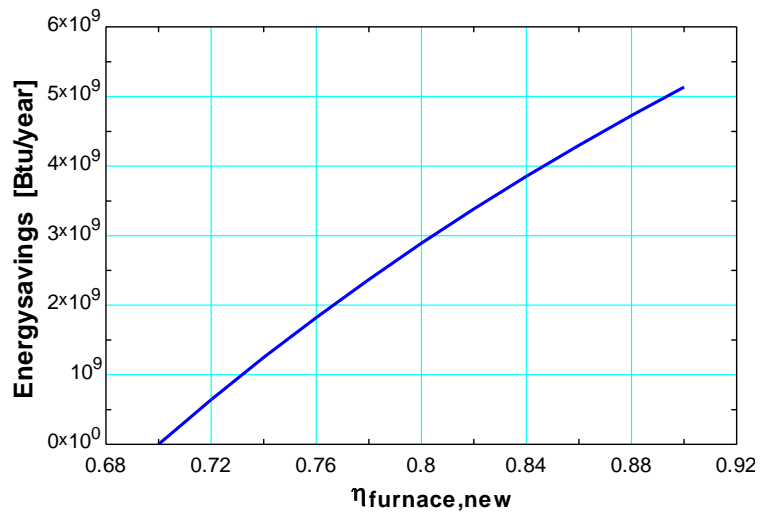

Table values are for UnitCost = 5E-5 [\$/Btu]

2-61 Geothermal water is raised from a given depth by a pump at a specified rate. For a given pump efficiency, the required power input to the pump is to be determined.

Assumptions 1 The pump operates steadily. 2 Frictional losses in the pipes are negligible. 3 The changes in kinetic energy are negligible. 4 The geothermal water is exposed to the atmosphere and thus its free surface is at atmospheric pressure.

Properties The density of geothermal water is given to be $\rho = 1050 \text{ kg/m}^3$.

Analysis The elevation of geothermal water and thus its potential energy changes, but it experiences no changes in its velocity and pressure. Therefore, the change in the total mechanical energy of geothermal water is equal to the change in its potential energy, which is gz per unit mass, and $\dot{m}gz$ for a given mass flow rate. That is,

$$\begin{aligned}\Delta \dot{E}_{\text{mech}} &= \dot{m} \Delta e_{\text{mech}} = \dot{m} \Delta pe = \dot{m} g \Delta z = \rho \dot{V} g \Delta z \\ &= (1050 \text{ kg/m}^3)(0.3 \text{ m}^3/\text{s})(9.81 \text{ m/s}^2)(200 \text{ m}) \left(\frac{1 \text{ N}}{1 \text{ kg} \cdot \text{m/s}^2} \right) \left(\frac{1 \text{ kW}}{1000 \text{ N} \cdot \text{m/s}} \right) \\ &= 618.0 \text{ kW}\end{aligned}$$

Then the required power input to the pump becomes

$$\dot{W}_{\text{pump,elect}} = \frac{\Delta \dot{E}_{\text{mech}}}{\eta_{\text{pump-motor}}} = \frac{618 \text{ kW}}{0.74} = \mathbf{835 \text{ kW}}$$

Discussion The frictional losses in piping systems are usually significant, and thus a larger pump will be needed to overcome these frictional losses.

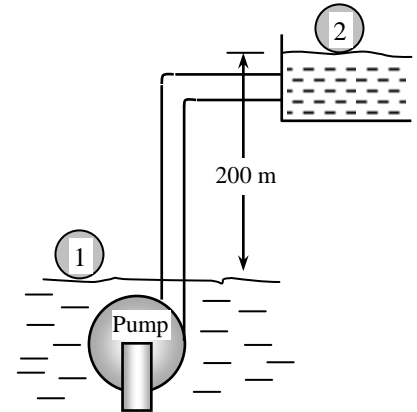

2-62 Several people are working out in an exercise room. The rate of heat gain from people and the equipment is to be determined.

Assumptions The average rate of heat dissipated by people in an exercise room is 600 W.

Analysis The 6 weight lifting machines do not have any motors, and thus they do not contribute to the internal heat gain directly. The usage factors of the motors of the treadmills are taken to be unity since they are used constantly during peak periods. Noting that 1 hp = 745.7 W, the total heat generated by the motors is

$$\begin{aligned}\dot{Q}_{\text{motors}} &= (\text{No. of motors}) \times \dot{W}_{\text{motor}} \times f_{\text{load}} \times f_{\text{usage}} / \eta_{\text{motor}} \\ &= 7 \times (2.5 \times 746 \text{ W}) \times 0.70 \times 1.0 / 0.77 = 11,870 \text{ W}\end{aligned}$$

The heat gain from 14 people is

$$\dot{Q}_{\text{people}} = 14 \times (600 \text{ W}) = 8400 \text{ W}$$

Then the total rate of heat gain of the exercise room during peak period becomes

$$\dot{Q}_{\text{total}} = \dot{Q}_{\text{motors}} + \dot{Q}_{\text{people}} = 11,870 + 8400 = \mathbf{20,270 \text{ W}}$$



2-63 A room is cooled by circulating chilled water through a heat exchanger, and the air is circulated through the heat exchanger by a fan. The contribution of the fan-motor assembly to the cooling load of the room is to be determined.

Assumptions The fan motor operates at full load so that $f_{load} = 1$.

Analysis The entire electrical energy consumed by the motor, including the shaft power delivered to the fan, is eventually dissipated as heat. Therefore, the contribution of the fan-motor assembly to the cooling load of the room is equal to the electrical energy it consumes,

$$\begin{aligned}\dot{Q}_{\text{internal generation}} &= \dot{W}_{\text{in,electric}} = \dot{W}_{\text{shaft}} / \eta_{\text{motor}} \\ &= (0.25 \text{ hp}) / 0.54 = 0.463 \text{ hp} = \mathbf{345 \text{ W}}\end{aligned}$$

since 1 hp = 746 W.

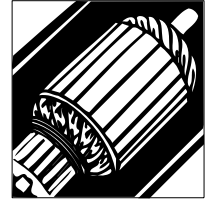

2-64 A hydraulic turbine-generator is to generate electricity from the water of a lake. The overall efficiency, the turbine efficiency, and the shaft power are to be determined.

Assumptions 1 The elevation of the lake and that of the discharge site remains constant. 2 Irreversible losses in the pipes are negligible.

Properties The density of water can be taken to be $\rho = 1000 \text{ kg/m}^3$. The gravitational acceleration is $g = 9.81 \text{ m/s}^2$.

Analysis (a) We take the bottom of the lake as the reference level for convenience. Then kinetic and potential energies of water are zero, and the mechanical energy of water consists of pressure energy only which is

$$\begin{aligned}e_{\text{mech,in}} - e_{\text{mech,out}} &= \frac{P}{\rho} = gh \\ &= (9.81 \text{ m/s}^2)(50 \text{ m}) \left(\frac{1 \text{ kJ/kg}}{1000 \text{ m}^2/\text{s}^2} \right) \\ &= 0.491 \text{ kJ/kg}\end{aligned}$$

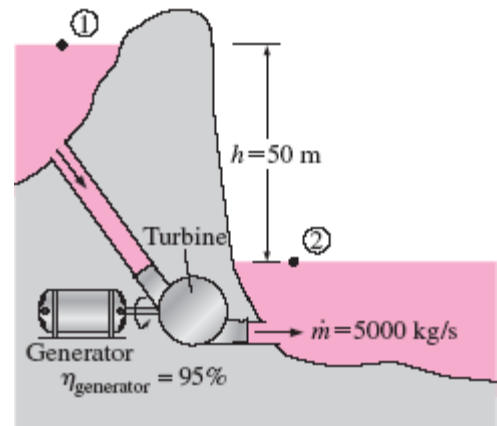

Then the rate at which mechanical energy of fluid supplied to the turbine and the overall efficiency become

$$|\Delta \dot{E}_{\text{mech,fluid}}| = \dot{m}(e_{\text{mech,in}} - e_{\text{mech,out}}) = (5000 \text{ kg/s})(0.491 \text{ kJ/kg}) = 2455 \text{ kW}$$

$$\eta_{\text{overall}} = \eta_{\text{turbine-gen}} = \frac{\dot{W}_{\text{elect,out}}}{|\Delta \dot{E}_{\text{mech,fluid}}|} = \frac{1862 \text{ kW}}{2455 \text{ kW}} = \mathbf{0.760}$$

(b) Knowing the overall and generator efficiencies, the mechanical efficiency of the turbine is determined from

$$\eta_{\text{turbine-gen}} = \eta_{\text{turbine}} \eta_{\text{generator}} \rightarrow \eta_{\text{turbine}} = \frac{\eta_{\text{turbine-gen}}}{\eta_{\text{generator}}} = \frac{0.76}{0.95} = \mathbf{0.800}$$

(c) The shaft power output is determined from the definition of mechanical efficiency,

$$\dot{W}_{\text{shaft,out}} = \eta_{\text{turbine}} |\Delta \dot{E}_{\text{mech,fluid}}| = (0.800)(2455 \text{ kW}) = 1964 \text{ kW} \approx \mathbf{1960 \text{ kW}}$$

Therefore, the lake supplies 2455 kW of mechanical energy to the turbine, which converts 1964 kW of it to shaft work that drives the generator, which generates 1862 kW of electric power.

2-65 A pump with a specified shaft power and efficiency is used to raise water to a higher elevation. The maximum flow rate of water is to be determined.

Assumptions 1 The flow is steady and incompressible. **2** The elevation difference between the reservoirs is constant. **3** We assume the flow in the pipes to be *frictionless* since the *maximum* flow rate is to be determined,

Properties We take the density of water to be $\rho = 1000 \text{ kg/m}^3$.

Analysis The useful pumping power (the part converted to mechanical energy of water) is

$$\dot{W}_{\text{pump,u}} = \eta_{\text{pump}} \dot{W}_{\text{pump,shaft}} = (0.82)(7 \text{ hp}) = 5.74 \text{ hp}$$

The elevation of water and thus its potential energy changes during pumping, but it experiences no changes in its velocity and pressure. Therefore, the change in the total mechanical energy of water is equal to the change in its potential energy, which is gz per unit mass, and $\dot{m}gz$ for a given mass flow rate. That is,

$$\Delta \dot{E}_{\text{mech}} = \dot{m} \Delta e_{\text{mech}} = \dot{m} \Delta pe = \dot{m} g \Delta z = \rho \dot{V} g \Delta z$$

Noting that $\Delta \dot{E}_{\text{mech}} = \dot{W}_{\text{pump,u}}$, the volume flow rate of water is determined to be

$$\dot{V} = \frac{\dot{W}_{\text{pump,u}}}{\rho g z_2} = \frac{5.74 \text{ hp}}{(1000 \text{ kg/m}^3)(9.81 \text{ m/s}^2)(15 \text{ m})} \left(\frac{745.7 \text{ W}}{1 \text{ hp}} \right) \left(\frac{1 \text{ N} \cdot \text{m/s}}{1 \text{ W}} \right) \left(\frac{1 \text{ kg} \cdot \text{m/s}^2}{1 \text{ N}} \right) = \mathbf{0.0291 \text{ m}^3/\text{s}}$$

Discussion This is the maximum flow rate since the frictional effects are ignored. In an actual system, the flow rate of water will be less because of friction in pipes.

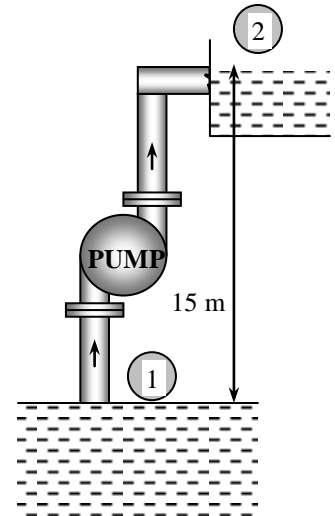

2-66 Wind is blowing steadily at a certain velocity. The mechanical energy of air per unit mass, the power generation potential, and the actual electric power generation are to be determined.

Assumptions 1 The wind is blowing steadily at a constant uniform velocity. **2** The efficiency of the wind turbine is independent of the wind speed.

Properties The density of air is given to be $\rho = 1.25 \text{ kg/m}^3$.

Analysis Kinetic energy is the only form of mechanical energy the wind possesses, and it can be converted to work entirely. Therefore, the power potential of the wind is its kinetic energy, which is $V^2/2$ per unit mass, and $\dot{m}V^2/2$ for a given mass flow rate:

$$e_{\text{mech}} = ke = \frac{V^2}{2} = \frac{(7 \text{ m/s})^2}{2} \left(\frac{1 \text{ kJ/kg}}{1000 \text{ m}^2/\text{s}^2} \right) = 0.0245 \text{ kJ/kg}$$

$$\dot{m} = \rho VA = \rho V \frac{\pi D^2}{4} = (1.25 \text{ kg/m}^3)(7 \text{ m/s}) \frac{\pi (80 \text{ m})^2}{4} = 43,982 \text{ kg/s}$$

$$\dot{W}_{\text{max}} = \dot{E}_{\text{mech}} = \dot{m} e_{\text{mech}} = (43,982 \text{ kg/s})(0.0245 \text{ kJ/kg}) = \mathbf{1078 \text{ kW}}$$

The actual electric power generation is determined by multiplying the power generation potential by the efficiency,

$$\dot{W}_{\text{elect}} = \eta_{\text{wind turbine}} \dot{W}_{\text{max}} = (0.30)(1078 \text{ kW}) = \mathbf{323 \text{ kW}}$$

Therefore, 323 kW of actual power can be generated by this wind turbine at the stated conditions.

Discussion The power generation of a wind turbine is proportional to the cube of the wind velocity, and thus the power generation will change strongly with the wind conditions.

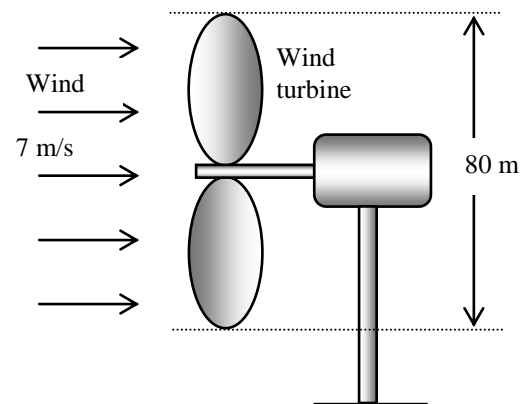



2-67 Problem 2-66 is reconsidered. The effect of wind velocity and the blade span diameter on wind power generation as the velocity varies from 5 m/s to 20 m/s in increments of 5 m/s, and the diameter varies from 20 m to 120 m in increments of 20 m is to be investigated.

Analysis The problem is solved using EES, and the solution is given below.

"Given"

V=7 [m/s]
 D=80 [m]
 eta_overall=0.30
 rho=1.25 [kg/m^3]

"Analysis"

g=9.81 [m/s^2]
 A=pi*D^2/4
 m_dot=rho*A*V
 W_dot_max=m_dot*V^2/2*Convert(m^2/s^2, kJ/kg)
 W_dot_elect=eta_overall*W_dot_max

Table 1	1	2	3	4
1..24	D [m]	V [m/s]	m_dot [kg/s]	W_dot_elect [kW]
Run 1	20	5	1963	7.363
Run 2	20	10	3927	58.9
Run 3	20	15	5890	198.8
Run 4	20	20	7854	471.2
Run 5	40	5	7854	29.45
Run 6	40	10	15708	235.6
Run 7	40	15	23562	795.2
Run 8	40	20	31416	1885
Run 9	60	5	17671	66.27
Run 10	60	10	35343	530.1
Run 11	60	15	53014	1789
Run 12	60	20	70686	4241
Run 13	80	5	31416	117.8
Run 14	80	10	62832	942.5
Run 15	80	15	94248	3181
Run 16	80	20	125664	7540
Run 17	100	5	49087	184.1
Run 18	100	10	98175	1473
Run 19	100	15	147262	4970
Run 20	100	20	196350	11781
Run 21	120	5	70686	265.1
Run 22	120	10	141372	2121
Run 23	120	15	212058	7157
Run 24	120	20	282743	16965

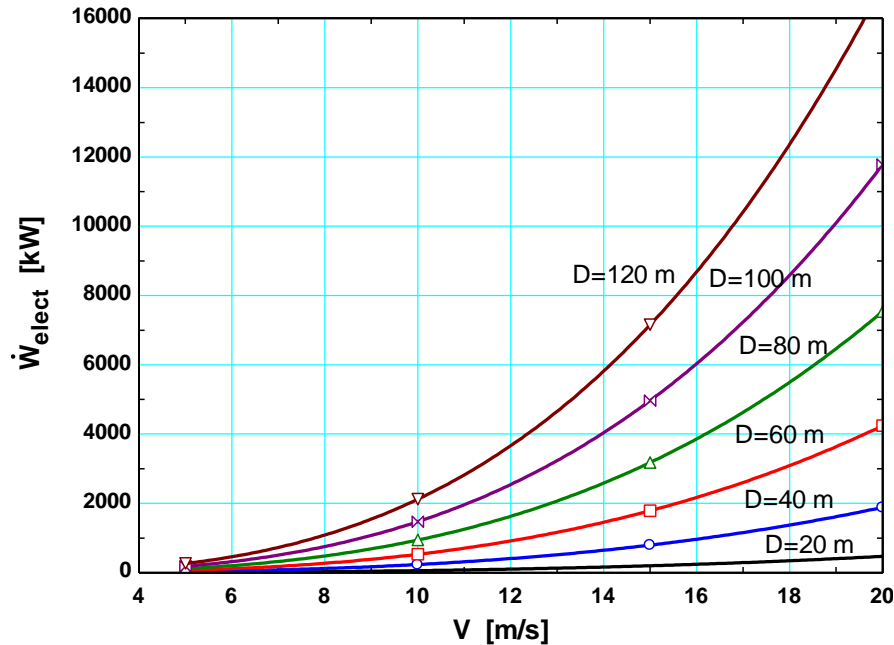

2-68 Water is pumped from a lake to a storage tank at a specified rate. The overall efficiency of the pump-motor unit and the pressure difference between the inlet and the exit of the pump are to be determined.

Assumptions 1 The elevations of the tank and the lake remain constant. **2** Frictional losses in the pipes are negligible. **3** The changes in kinetic energy are negligible. **4** The elevation difference across the pump is negligible.

Properties We take the density of water to be $\rho = 1000 \text{ kg/m}^3$.

Analysis (a) We take the free surface of the lake to be point 1 and the free surfaces of the storage tank to be point 2. We also take the lake surface as the reference level ($z_1 = 0$), and thus the potential energy at points 1 and 2 are $pe_1 = 0$ and $pe_2 = gz_2$. The flow energy at both points is zero since both 1 and 2 are open to the atmosphere ($P_1 = P_2 = P_{\text{atm}}$). Further, the kinetic energy at both points is zero ($ke_1 = ke_2 = 0$) since the water at both locations is essentially stationary. The mass flow rate of water and its potential energy at point 2 are

$$\dot{m} = \rho \dot{V} = (1000 \text{ kg/m}^3)(0.070 \text{ m}^3/\text{s}) = 70 \text{ kg/s}$$

$$pe_2 = gz_2 = (9.81 \text{ m/s}^2)(15 \text{ m}) \left(\frac{1 \text{ kJ/kg}}{1000 \text{ m}^2/\text{s}^2} \right) = 0.1472 \text{ kJ/kg}$$

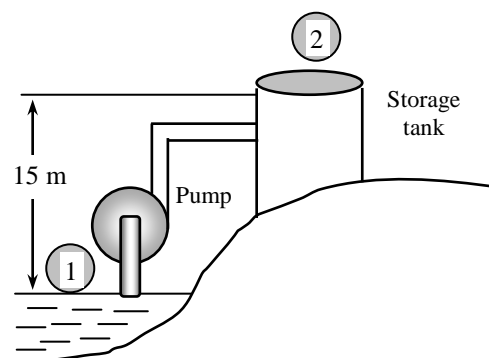

Then the rate of increase of the mechanical energy of water becomes

$$\Delta \dot{E}_{\text{mech,fluid}} = \dot{m}(e_{\text{mech,out}} - e_{\text{mech,in}}) = \dot{m}(pe_2 - 0) = \dot{m}pe_2 = (70 \text{ kg/s})(0.1472 \text{ kJ/kg}) = 10.3 \text{ kW}$$

The overall efficiency of the combined pump-motor unit is determined from its definition,

$$\eta_{\text{pump-motor}} = \frac{\Delta \dot{E}_{\text{mech,fluid}}}{\dot{W}_{\text{elect,in}}} = \frac{10.3 \text{ kW}}{15.4 \text{ kW}} = 0.669 \quad \text{or} \quad \mathbf{66.9\%}$$

(b) Now we consider the pump. The change in the mechanical energy of water as it flows through the pump consists of the change in the flow energy only since the elevation difference across the pump and the change in the kinetic energy are negligible. Also, this change must be equal to the useful mechanical energy supplied by the pump, which is 10.3 kW:

$$\Delta \dot{E}_{\text{mech,fluid}} = \dot{m}(e_{\text{mech,out}} - e_{\text{mech,in}}) = \dot{m} \frac{P_2 - P_1}{\rho} = \dot{V} \Delta P$$

Solving for ΔP and substituting,

$$\Delta P = \frac{\Delta \dot{E}_{\text{mech,fluid}}}{\dot{V}} = \frac{10.3 \text{ kJ/s}}{0.070 \text{ m}^3/\text{s}} \left(\frac{1 \text{ kPa} \cdot \text{m}^3}{1 \text{ kJ}} \right) = \mathbf{147 \text{ kPa}}$$

Therefore, the pump must boost the pressure of water by 147 kPa in order to raise its elevation by 15 m.

Discussion Note that only two-thirds of the electric energy consumed by the pump-motor is converted to the mechanical energy of water; the remaining one-third is wasted because of the inefficiencies of the pump and the motor.

2-69 A large wind turbine is installed at a location where the wind is blowing steadily at a certain velocity. The electric power generation, the daily electricity production, and the monetary value of this electricity are to be determined.

Assumptions 1 The wind is blowing steadily at a constant uniform velocity. **2** The efficiency of the wind turbine is independent of the wind speed.

Properties The density of air is given to be $\rho = 1.25 \text{ kg/m}^3$.

Analysis Kinetic energy is the only form of mechanical energy the wind possesses, and it can be converted to work entirely. Therefore, the power potential of the wind is its kinetic energy, which is $V^2/2$ per unit mass, and $\dot{m}V^2/2$ for a given mass flow rate:

$$e_{\text{mech}} = ke = \frac{V^2}{2} = \frac{(8 \text{ m/s})^2}{2} \left(\frac{1 \text{ kJ/kg}}{1000 \text{ m}^2/\text{s}^2} \right) = 0.032 \text{ kJ/kg}$$

$$\dot{m} = \rho VA = \rho V \frac{\pi D^2}{4} = (1.25 \text{ kg/m}^3)(8 \text{ m/s}) \frac{\pi(100 \text{ m})^2}{4} = 78,540 \text{ kg/s}$$

$$\dot{W}_{\text{max}} = \dot{E}_{\text{mech}} = \dot{m}e_{\text{mech}} = (78,540 \text{ kg/s})(0.032 \text{ kJ/kg}) = 2513 \text{ kW}$$

The actual electric power generation is determined from

$$\dot{W}_{\text{elect}} = \eta_{\text{wind turbine}} \dot{W}_{\text{max}} = (0.32)(2513 \text{ kW}) = \mathbf{804.2 \text{ kW}}$$

Then the amount of electricity generated per day and its monetary value become

$$\text{Amount of electricity} = (\text{Wind power})(\text{Operating hours}) = (804.2 \text{ kW})(24 \text{ h}) = \mathbf{19,300 \text{ kWh}}$$

$$\text{Revenues} = (\text{Amount of electricity})(\text{Unit price}) = (19,300 \text{ kWh})(\$0.09/\text{kWh}) = \mathbf{\$1737} \text{ (per day)}$$

Discussion Note that a single wind turbine can generate several thousand dollars worth of electricity every day at a reasonable cost, which explains the overwhelming popularity of wind turbines in recent years.

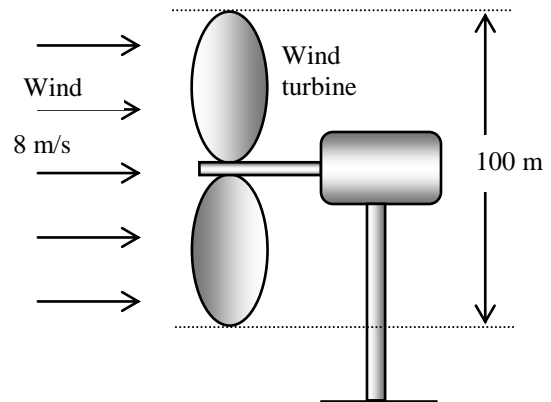

2-70 The available head of a hydraulic turbine and its overall efficiency are given. The electric power output of this turbine is to be determined.

Assumptions 1 The flow is steady and incompressible. **2** The elevation of the reservoir remains constant.

Properties We take the density of water to be $\rho = 1000 \text{ kg/m}^3$.

Analysis The total mechanical energy the water in a reservoir possesses is equivalent to the potential energy of water at the free surface, and it can be converted to work entirely. Therefore, the power potential of water is its potential energy, which is gz per unit mass, and $\dot{m}gz$ for a given mass flow rate. Therefore, the actual power produced by the turbine can be expressed as

$$\dot{W}_{\text{turbine}} = \eta_{\text{turbine}} \dot{m}gh_{\text{turbine}} = \eta_{\text{turbine}} \rho \dot{V}gh_{\text{turbine}}$$

Substituting,

$$\dot{W}_{\text{turbine}} = (0.91)(1000 \text{ kg/m}^3)(0.25 \text{ m}^3/\text{s})(9.81 \text{ m/s}^2)(85 \text{ m}) \left(\frac{1 \text{ N}}{1 \text{ kg} \cdot \text{m/s}^2} \right) \left(\frac{1 \text{ kW}}{1000 \text{ N} \cdot \text{m/s}} \right) = \mathbf{190 \text{ kW}}$$

Discussion Note that the power output of a hydraulic turbine is proportional to the available elevation difference (turbine head) and the flow rate.

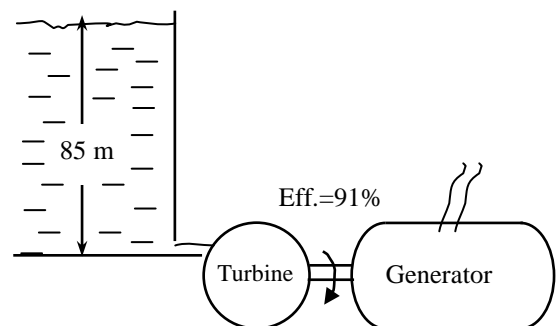

2-71E A water pump raises the pressure of water by a specified amount at a specified flow rate while consuming a known amount of electric power. The mechanical efficiency of the pump is to be determined.

Assumptions 1 The pump operates steadily. 2 The changes in velocity and elevation across the pump are negligible. 3 Water is incompressible.

Analysis To determine the mechanical efficiency of the pump, we need to know the increase in the mechanical energy of the fluid as it flows through the pump, which is

$$\begin{aligned}
 \Delta \dot{E}_{\text{mech,fluid}} &= \dot{m}(e_{\text{mech,out}} - e_{\text{mech,in}}) \\
 &= \dot{m}[(P\boldsymbol{v})_2 - (P\boldsymbol{v})_1] \\
 &= \dot{m}(P_2 - P_1)\boldsymbol{v} \\
 &= \dot{V}(P_2 - P_1) \\
 &= (15 \text{ ft}^3/\text{s})(1.2 \text{ psi}) \left(\frac{1 \text{ Btu}}{5.404 \text{ psi} \cdot \text{ft}^3} \right) \\
 &= 3.33 \text{ Btu/s} = 4.71 \text{ hp}
 \end{aligned}$$

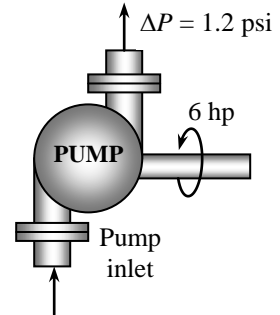

since $1 \text{ hp} = 0.7068 \text{ Btu/s}$, $\dot{m} = \rho \dot{V} = \dot{V} / \boldsymbol{v}$, and there is no change in kinetic and potential energies of the fluid. Then the mechanical efficiency of the pump becomes

$$\eta_{\text{pump}} = \frac{\Delta \dot{E}_{\text{mech,fluid}}}{\dot{W}_{\text{pump,shaft}}} = \frac{4.71 \text{ hp}}{6 \text{ hp}} = 0.786 \quad \text{or} \quad \mathbf{78.6\%}$$

Discussion The overall efficiency of this pump will be lower than 83.8% because of the inefficiency of the electric motor that drives the pump.

2-72 Water is pumped from a lower reservoir to a higher reservoir at a specified rate. For a specified shaft power input, the power that is converted to thermal energy is to be determined.

Assumptions 1 The pump operates steadily. 2 The elevations of the reservoirs remain constant. 3 The changes in kinetic energy are negligible.

Properties We take the density of water to be $\rho = 1000 \text{ kg/m}^3$.

Analysis The elevation of water and thus its potential energy changes during pumping, but it experiences no changes in its velocity and pressure. Therefore, the change in the total mechanical energy of water is equal to the change in its potential energy, which is gz per unit mass, and $\dot{m}gz$ for a given mass flow rate. That is,

$$\begin{aligned}\Delta \dot{E}_{\text{mech}} &= \dot{m} \Delta e_{\text{mech}} = \dot{m} \Delta pe = \dot{m} g \Delta z = \rho \dot{V} g \Delta z \\ &= (1000 \text{ kg/m}^3)(0.03 \text{ m}^3/\text{s})(9.81 \text{ m/s}^2)(45 \text{ m}) \left(\frac{1 \text{ N}}{1 \text{ kg} \cdot \text{m/s}^2} \right) \left(\frac{1 \text{ kW}}{1000 \text{ N} \cdot \text{m/s}} \right) = 13.2 \text{ kW}\end{aligned}$$

Then the mechanical power lost because of frictional effects becomes

$$\dot{W}_{\text{frict}} = \dot{W}_{\text{pump,in}} - \Delta \dot{E}_{\text{mech}} = 20 - 13.2 \text{ kW} = \mathbf{6.8 \text{ kW}}$$

Discussion The 6.8 kW of power is used to overcome the friction in the piping system. The effect of frictional losses in a pump is always to convert mechanical energy to an equivalent amount of thermal energy, which results in a slight rise in fluid temperature. Note that this pumping process could be accomplished by a 13.2 kW pump (rather than 20 kW) if there were no frictional losses in the system. In this ideal case, the pump would function as a turbine when the water is allowed to flow from the upper reservoir to the lower reservoir and extract 13.2 kW of power from the water.

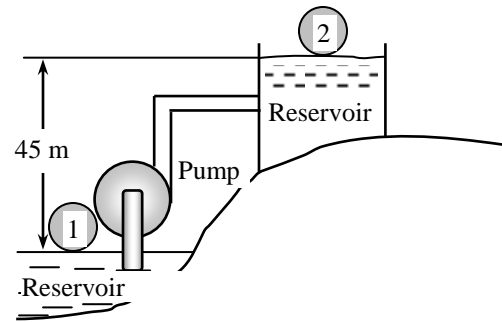

2-73 The mass flow rate of water through the hydraulic turbines of a dam is to be determined.

Analysis The mass flow rate is determined from

$$\dot{W} = \dot{m}g(z_2 - z_1) \longrightarrow \dot{m} = \frac{\dot{W}}{g(z_2 - z_1)} = \frac{100,000 \text{ kJ/s}}{(9.8 \text{ m/s}^2)(206 - 0) \text{ m}} \left(\frac{1 \text{ kJ/kg}}{1000 \text{ m}^2/\text{s}^2} \right) = \mathbf{49,500 \text{ kg/s}}$$

2-74 A pump is pumping oil at a specified rate. The pressure rise of oil in the pump is measured, and the motor efficiency is specified. The mechanical efficiency of the pump is to be determined.

Assumptions 1 The flow is steady and incompressible. 2 The elevation difference across the pump is negligible.

Properties The density of oil is given to be $\rho = 860 \text{ kg/m}^3$.

Analysis Then the total mechanical energy of a fluid is the sum of the potential, flow, and kinetic energies, and is expressed per unit mass as $e_{\text{mech}} = gh + Pv + V^2/2$. To determine the mechanical efficiency of the pump, we need to know the increase in the mechanical energy of the fluid as it flows through the pump, which is

$$\Delta \dot{E}_{\text{mech,fluid}} = \dot{m}(e_{\text{mech,out}} - e_{\text{mech,in}}) = \dot{m} \left[(Pv)_2 + \frac{V_2^2}{2} - (Pv)_1 - \frac{V_1^2}{2} \right] = \dot{V} \left[(P_2 - P_1) + \rho \frac{V_2^2 - V_1^2}{2} \right]$$

since $\dot{m} = \rho \dot{V} = \dot{V}/\nu$, and there is no change in the potential energy of the fluid. Also,

$$V_1 = \frac{\dot{V}}{A_1} = \frac{\dot{V}}{\pi D_1^2 / 4} = \frac{0.1 \text{ m}^3/\text{s}}{\pi (0.08 \text{ m})^2 / 4} = 19.9 \text{ m/s}$$

$$V_2 = \frac{\dot{V}}{A_2} = \frac{\dot{V}}{\pi D_2^2 / 4} = \frac{0.1 \text{ m}^3/\text{s}}{\pi (0.12 \text{ m})^2 / 4} = 8.84 \text{ m/s}$$

Substituting, the useful pumping power is determined to be

$$\begin{aligned} \dot{W}_{\text{pump,u}} &= \Delta \dot{E}_{\text{mech,fluid}} \\ &= (0.1 \text{ m}^3/\text{s}) \left[500 \text{ kN/m}^2 + (860 \text{ kg/m}^3) \frac{(8.84 \text{ m/s})^2 - (19.9 \text{ m/s})^2}{2} \right] \left(\frac{1 \text{ kN}}{1000 \text{ kg} \cdot \text{m/s}^2} \right) \left(\frac{1 \text{ kW}}{1 \text{ kN} \cdot \text{m/s}} \right) \\ &= 36.3 \text{ kW} \end{aligned}$$

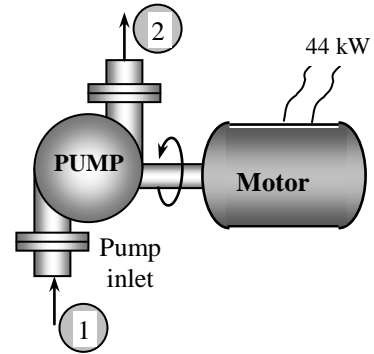

Then the shaft power and the mechanical efficiency of the pump become

$$\dot{W}_{\text{pump,shaft}} = \eta_{\text{motor}} \dot{W}_{\text{electric}} = (0.90)(44 \text{ kW}) = 39.6 \text{ kW}$$

$$\eta_{\text{pump}} = \frac{\dot{W}_{\text{pump,u}}}{\dot{W}_{\text{pump,shaft}}} = \frac{36.3 \text{ kW}}{39.6 \text{ kW}} = 0.918 = \mathbf{91.8\%}$$

Discussion The overall efficiency of this pump/motor unit is the product of the mechanical and motor efficiencies, which is $0.9 \times 0.918 = 0.826$.

Energy and Environment

2-75C Energy conversion pollutes the soil, the water, and the air, and the environmental pollution is a serious threat to vegetation, wild life, and human health. The emissions emitted during the combustion of fossil fuels are responsible for smog, acid rain, and global warming and climate change. The primary chemicals that pollute the air are hydrocarbons (HC, also referred to as volatile organic compounds, VOC), nitrogen oxides (NO_x), and carbon monoxide (CO). The primary source of these pollutants is the motor vehicles.

2-76C Fossil fuels include small amounts of sulfur. The sulfur in the fuel reacts with oxygen to form sulfur dioxide (SO₂), which is an air pollutant. The sulfur oxides and nitric oxides react with water vapor and other chemicals high in the atmosphere in the presence of sunlight to form sulfuric and nitric acids. The acids formed usually dissolve in the suspended water droplets in clouds or fog. These acid-laden droplets are washed from the air on to the soil by rain or snow. This is known as *acid rain*. It is called “rain” since it comes down with rain droplets.

As a result of acid rain, many lakes and rivers in industrial areas have become too acidic for fish to grow. Forests in those areas also experience a slow death due to absorbing the acids through their leaves, needles, and roots. Even marble structures deteriorate due to acid rain.

2-77C Carbon monoxide, which is a colorless, odorless, poisonous gas that deprives the body's organs from getting enough oxygen by binding with the red blood cells that would otherwise carry oxygen. At low levels, carbon monoxide decreases the amount of oxygen supplied to the brain and other organs and muscles, slows body reactions and reflexes, and impairs judgment. It poses a serious threat to people with heart disease because of the fragile condition of the circulatory system and to fetuses because of the oxygen needs of the developing brain. At high levels, it can be fatal, as evidenced by numerous deaths caused by cars that are warmed up in closed garages or by exhaust gases leaking into the cars.

2-78C Carbon dioxide (CO₂), water vapor, and trace amounts of some other gases such as methane and nitrogen oxides act like a blanket and keep the earth warm at night by blocking the heat radiated from the earth. This is known as the *greenhouse effect*. The greenhouse effect makes life on earth possible by keeping the earth warm. But excessive amounts of these gases disturb the delicate balance by trapping too much energy, which causes the average temperature of the earth to rise and the climate at some localities to change. These undesirable consequences of the greenhouse effect are referred to as *global warming* or *global climate change*. The greenhouse effect can be reduced by reducing the net production of CO₂ by consuming less energy (for example, by buying energy efficient cars and appliances) and planting trees.

2-79C Smog is the brown haze that builds up in a large stagnant air mass, and hangs over populated areas on calm hot summer days. Smog is made up mostly of ground-level ozone (O₃), but it also contains numerous other chemicals, including carbon monoxide (CO), particulate matter such as soot and dust, volatile organic compounds (VOC) such as benzene, butane, and other hydrocarbons. Ground-level ozone is formed when hydrocarbons and nitrogen oxides react in the presence of sunlight in hot calm days. Ozone irritates eyes and damage the air sacs in the lungs where oxygen and carbon dioxide are exchanged, causing eventual hardening of this soft and spongy tissue. It also causes shortness of breath, wheezing, fatigue, headaches, nausea, and aggravate respiratory problems such as asthma.

2-80E A person trades in his Ford Taurus for a Ford Explorer. The extra amount of CO₂ emitted by the Explorer within 5 years is to be determined.

Assumptions The Explorer is assumed to use 850 gallons of gasoline a year compared to 650 gallons for Taurus.

Analysis The extra amount of gasoline the Explorer will use within 5 years is

$$\begin{aligned}\text{Extra Gasoline} &= (\text{Extra per year})(\text{No. of years}) \\ &= (850 - 650 \text{ gal/yr})(5 \text{ yr}) \\ &= 1000 \text{ gal}\end{aligned}$$

$$\begin{aligned}\text{Extra CO}_2 \text{ produced} &= (\text{Extra gallons of gasoline used})(\text{CO}_2 \text{ emission per gallon}) \\ &= (1000 \text{ gal})(19.7 \text{ lbm/gal}) \\ &= \mathbf{19,700 \text{ lbm CO}_2}\end{aligned}$$

Discussion Note that the car we choose to drive has a significant effect on the amount of greenhouse gases produced.

2-81E A household uses fuel oil for heating, and electricity for other energy needs. Now the household reduces its energy use by 15%. The reduction in the CO₂ production this household is responsible for is to be determined.

Properties The amount of CO₂ produced is 1.54 lbm per kWh and 26.4 lbm per gallon of fuel oil (given).

Analysis Noting that this household consumes 14,000 kWh of electricity and 900 gallons of fuel oil per year, the amount of CO₂ production this household is responsible for is

$$\begin{aligned}\text{Amount of CO}_2 \text{ produced} &= (\text{Amount of electricity consumed})(\text{Amount of CO}_2 \text{ per kWh}) \\ &\quad + (\text{Amount of fuel oil consumed})(\text{Amount of CO}_2 \text{ per gallon}) \\ &= (14,000 \text{ kWh/yr})(1.54 \text{ lbm/kWh}) + (900 \text{ gal/yr})(26.4 \text{ lbm/gal}) \\ &= 45,320 \text{ CO}_2 \text{ lbm/year}\end{aligned}$$

Then reducing the electricity and fuel oil usage by 15% will reduce the annual amount of CO₂ production by this household by

$$\begin{aligned}\text{Reduction in CO}_2 \text{ produced} &= (0.15)(\text{Current amount of CO}_2 \text{ production}) \\ &= (0.15)(45,320 \text{ CO}_2 \text{ kg/year}) \\ &= \mathbf{6798 \text{ CO}_2 \text{ lbm/year}}\end{aligned}$$

Therefore, any measure that saves energy also reduces the amount of pollution emitted to the environment.

2-82 A power plant that burns natural gas produces 0.59 kg of carbon dioxide (CO₂) per kWh. The amount of CO₂ production that is due to the refrigerators in a city is to be determined.

Assumptions The city uses electricity produced by a natural gas power plant.

Properties 0.59 kg of CO₂ is produced per kWh of electricity generated (given).

Analysis Noting that there are 300,000 households in the city and each household consumes 700 kWh of electricity for refrigeration, the total amount of CO₂ produced is

$$\begin{aligned}\text{Amount of CO}_2 \text{ produced} &= (\text{Amount of electricity consumed})(\text{Amount of CO}_2 \text{ per kWh}) \\ &= (300,000 \text{ household})(700 \text{ kWh/year household})(0.59 \text{ kg/kWh}) \\ &= 1.23 \times 10^8 \text{ CO}_2 \text{ kg/year} \\ &= \mathbf{123,000 \text{ CO}_2 \text{ ton/year}}\end{aligned}$$

Therefore, the refrigerators in this city are responsible for the production of 123,000 tons of CO₂.

2-83 A power plant that burns coal, produces 1.1 kg of carbon dioxide (CO₂) per kWh. The amount of CO₂ production that is due to the refrigerators in a city is to be determined.

Assumptions The city uses electricity produced by a coal power plant.

Properties 1.1 kg of CO₂ is produced per kWh of electricity generated (given).

Analysis Noting that there are 300,000 households in the city and each household consumes 700 kWh of electricity for refrigeration, the total amount of CO₂ produced is

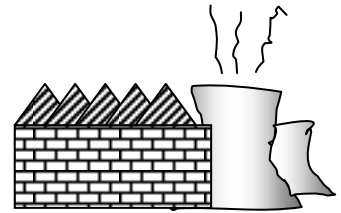

$$\begin{aligned}\text{Amount of CO}_2 \text{ produced} &= (\text{Amount of electricity consumed})(\text{Amount of CO}_2 \text{ per kWh}) \\ &= (300,000 \text{ household})(700 \text{ kWh/household})(1.1 \text{ kg/kWh}) \\ &= 2.31 \times 10^8 \text{ CO}_2 \text{ kg/year} \\ &= \mathbf{231,000 \text{ CO}_2 \text{ ton/year}}\end{aligned}$$

Therefore, the refrigerators in this city are responsible for the production of 231,000 tons of CO₂.

2-84 A household has 2 cars, a natural gas furnace for heating, and uses electricity for other energy needs. The annual amount of NO_x emission to the atmosphere this household is responsible for is to be determined.

Properties The amount of NO_x produced is 7.1 g per kWh, 4.3 g per therm of natural gas, and 11 kg per car (given).

Analysis Noting that this household has 2 cars, consumes 1200 therms of natural gas, and 9,000 kWh of electricity per year, the amount of NO_x production this household is responsible for is



$$\begin{aligned}
 \text{Amount of } \text{NO}_x \text{ produced} &= (\text{No. of cars})(\text{Amount of } \text{NO}_x \text{ produced per car}) \\
 &+ (\text{Amount of electricity consumed})(\text{Amount of } \text{NO}_x \text{ per kWh}) \\
 &+ (\text{Amount of gas consumed})(\text{Amount of } \text{NO}_x \text{ per gallon}) \\
 &= (2 \text{ cars})(11 \text{ kg/car}) + (9000 \text{ kWh/yr})(0.0071 \text{ kg/kWh}) \\
 &\quad + (1200 \text{ therms/yr})(0.0043 \text{ kg/therm}) \\
 &= \mathbf{91.06 \text{ NO}_x \text{ kg/year}}
 \end{aligned}$$

Discussion Any measure that saves energy will also reduce the amount of pollution emitted to the atmosphere.

Special Topic: Mechanisms of Heat Transfer

2-85C The three mechanisms of heat transfer are conduction, convection, and radiation.

2-86C Diamond has a higher thermal conductivity than silver, and thus diamond is a better conductor of heat.

2-87C In forced convection, the fluid is forced to move by external means such as a fan, pump, or the wind. The fluid motion in natural convection is due to buoyancy effects only.

2-88C A blackbody is an idealized body that emits the maximum amount of radiation at a given temperature, and that absorbs all the radiation incident on it. Real bodies emit and absorb less radiation than a blackbody at the same temperature.

2-89C Emissivity is the ratio of the radiation emitted by a surface to the radiation emitted by a blackbody at the same temperature. Absorptivity is the fraction of radiation incident on a surface that is absorbed by the surface. The Kirchhoff's law of radiation states that the emissivity and the absorptivity of a surface are equal at the same temperature and wavelength.

2-90C No. It is purely by radiation.

2-91 The inner and outer surfaces of a brick wall are maintained at specified temperatures. The rate of heat transfer through the wall is to be determined.

Assumptions **1** Steady operating conditions exist since the surface temperatures of the wall remain constant at the specified values. **2** Thermal properties of the wall are constant.

Properties The thermal conductivity of the wall is given to be $k = 0.69 \text{ W/m}\cdot^\circ\text{C}$.

Analysis Under steady conditions, the rate of heat transfer through the wall is

$$\dot{Q}_{\text{cond}} = kA \frac{\Delta T}{L} = (0.69 \text{ W/m}\cdot^\circ\text{C})(5 \times 6 \text{ m}^2) \frac{(20 - 5)^\circ\text{C}}{0.3 \text{ m}} = \mathbf{1035 \text{ W}}$$

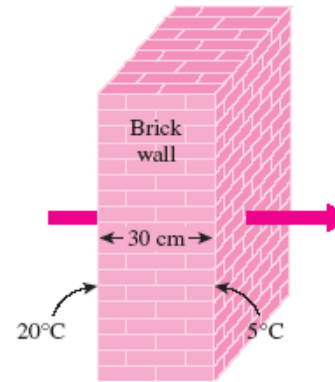

2-92 The inner and outer surfaces of a window glass are maintained at specified temperatures. The amount of heat transferred through the glass in 5 h is to be determined.

Assumptions **1** Steady operating conditions exist since the surface temperatures of the glass remain constant at the specified values. **2** Thermal properties of the glass are constant.

Properties The thermal conductivity of the glass is given to be $k = 0.78 \text{ W/m}\cdot^\circ\text{C}$.

Analysis Under steady conditions, the rate of heat transfer through the glass by conduction is

$$\dot{Q}_{\text{cond}} = kA \frac{\Delta T}{L} = (0.78 \text{ W/m}\cdot^\circ\text{C})(2 \times 2 \text{ m}^2) \frac{(15 - 6)^\circ\text{C}}{0.005 \text{ m}} = 5616 \text{ W}$$

Then the amount of heat transferred over a period of 10 h becomes

$$Q = \dot{Q}_{\text{cond}} \Delta t = (5.616 \text{ kJ/s})(10 \times 3600 \text{ s}) = \mathbf{202,200 \text{ kJ}}$$

If the thickness of the glass is doubled to 1 cm, then the amount of heat transferred will go down by half to **101,100 kJ**.

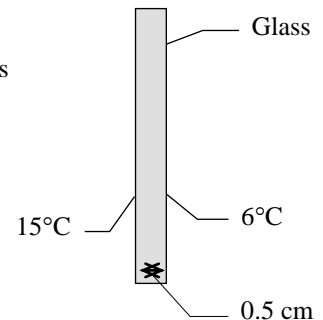



2-93 Reconsider Prob. 2-92. Using EES (or other) software, investigate the effect of glass thickness on heat loss for the specified glass surface temperatures. Let the glass thickness vary from 0.2 cm to 2 cm. Plot the heat loss versus the glass thickness, and discuss the results.

Analysis The problem is solved using EES, and the solution is given below.

```

FUNCTION klookup(material$)
If material$='Glass' then klookup:=0.78
If material$='Brick' then klookup:=0.72
If material$='Fiber Glass' then klookup:=0.043
If material$='Air' then klookup:=0.026
If material$='Wood(oak)' then klookup:=0.17

END

L=2 [m]
W=2 [m]
material$='Glass'
T_in=15 [C]
T_out=6 [C]
k=0.78 [W/m-C]
t=10 [hr]
thickness=0.5 [cm]
A=L*W
Q_dot_loss=A*k*(T_in-T_out)/(thickness*convert(cm,m))
Q_loss_total=Q_dot_loss*t*convert(hr,s)*convert(J,kJ)

```

Thickness [cm]	$Q_{\text{loss,total}}$ [kJ]
0.2	505440
0.4	252720
0.6	168480
0.8	126360
1	101088
1.2	84240
1.4	72206
1.6	63180
1.8	56160
2	50544

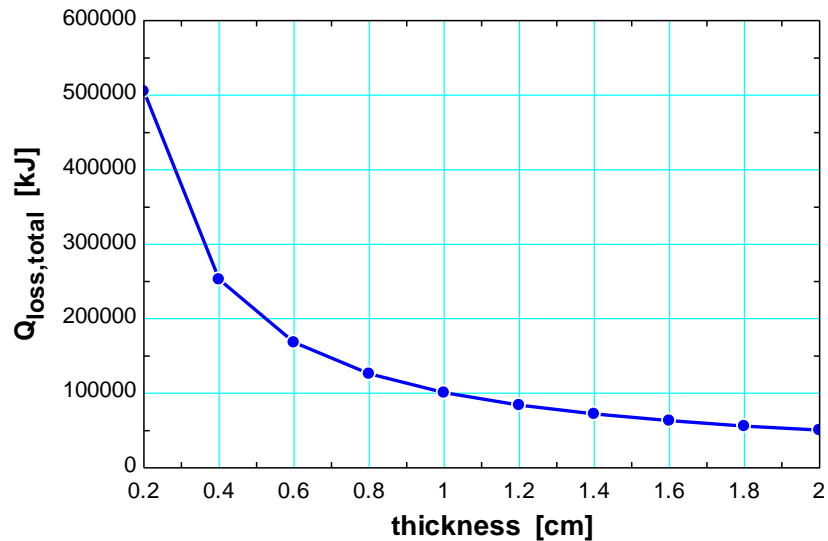

2-94 Heat is transferred steadily to boiling water in the pan through its bottom. The inner surface temperature of the bottom of the pan is given. The temperature of the outer surface is to be determined.

Assumptions 1 Steady operating conditions exist since the surface temperatures of the pan remain constant at the specified values. 2 Thermal properties of the aluminum pan are constant.

Properties The thermal conductivity of the aluminum is given to be $k = 237 \text{ W/m}\cdot\text{C}$.

Analysis The heat transfer surface area is

$$A = \pi r^2 = \pi(0.1 \text{ m})^2 = 0.0314 \text{ m}^2$$

Under steady conditions, the rate of heat transfer through the bottom of the pan by conduction is

$$\dot{Q} = kA \frac{\Delta T}{L} = kA \frac{T_2 - T_1}{L}$$

Substituting,

$$700 \text{ W} = (237 \text{ W/m}\cdot\text{C})(0.0314 \text{ m}^2) \frac{T_2 - 105^\circ\text{C}}{0.006 \text{ m}}$$

which gives

$$T_2 = \mathbf{105.6^\circ\text{C}}$$

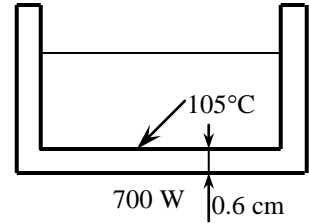

2-95 The inner and outer glasses of a double pane window with a 1-cm air space are at specified temperatures. The rate of heat transfer through the window is to be determined.

Assumptions 1 Steady operating conditions exist since the surface temperatures of the glass remain constant at the specified values. 2 Heat transfer through the window is one-dimensional. 3 Thermal properties of the air are constant. 4 The air trapped between the two glasses is still, and thus heat transfer is by conduction only.

Properties The thermal conductivity of air at room temperature is $k = 0.026 \text{ W/m}\cdot\text{C}$ (Table 2-3).

Analysis Under steady conditions, the rate of heat transfer through the window by conduction is

$$\dot{Q}_{\text{cond}} = kA \frac{\Delta T}{L} = (0.026 \text{ W/m}\cdot\text{C})(2 \times 2 \text{ m}^2) \frac{(18 - 6)^\circ\text{C}}{0.01 \text{ m}} = \mathbf{125 \text{ W} = 0.125 \text{ kW}}$$

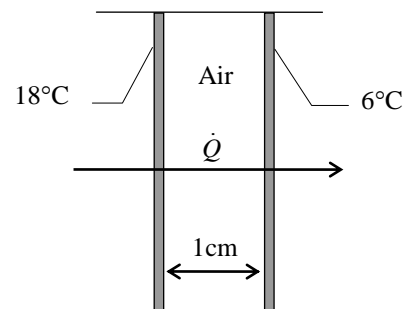

2-96 Two surfaces of a flat plate are maintained at specified temperatures, and the rate of heat transfer through the plate is measured. The thermal conductivity of the plate material is to be determined.

Assumptions 1 Steady operating conditions exist since the surface temperatures of the plate remain constant at the specified values. **2** Heat transfer through the plate is one-dimensional. **3** Thermal properties of the plate are constant.

Analysis The thermal conductivity is determined directly from the steady one-dimensional heat conduction relation to be

$$\dot{Q} = kA \frac{T_1 - T_2}{L}$$

$$k = \frac{(\dot{Q}/A)L}{T_1 - T_2} = \frac{(500 \text{ W/m}^2)(0.02 \text{ m})}{(100 - 0)^\circ\text{C}} = \mathbf{0.1 \text{ W/m}\cdot^\circ\text{C}}$$

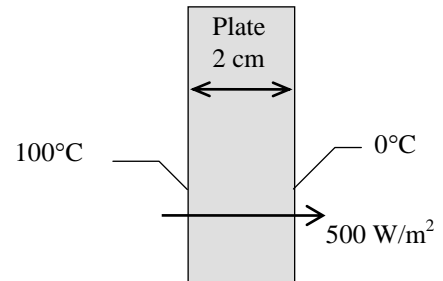

2-97 Hot air is blown over a flat surface at a specified temperature. The rate of heat transfer from the air to the plate is to be determined.

Assumptions 1 Steady operating conditions exist. **2** Heat transfer by radiation is not considered. **3** The convection heat transfer coefficient is constant and uniform over the surface.

Analysis Under steady conditions, the rate of heat transfer by convection is

$$\begin{aligned} \dot{Q}_{\text{conv}} &= hA\Delta T \\ &= (55 \text{ W/m}^2 \cdot ^\circ\text{C})(2 \times 4 \text{ m}^2)(80 - 30)^\circ\text{C} \\ &= \mathbf{22,000 \text{ W} = 22 \text{ kW}} \end{aligned}$$

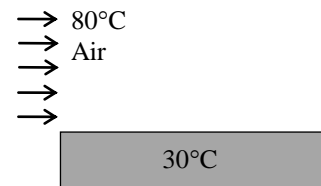

2-98 A person is standing in a room at a specified temperature. The rate of heat transfer between a person and the surrounding air by convection is to be determined.

Assumptions 1 Steady operating conditions exist. **2** Heat transfer by radiation is not considered. **3** The environment is at a uniform temperature.

Analysis The heat transfer surface area of the person is

$$A = \pi DL = \pi(0.3 \text{ m})(1.75 \text{ m}) = 1.649 \text{ m}^2$$

Under steady conditions, the rate of heat transfer by convection is

$$\dot{Q}_{\text{conv}} = hA\Delta T = (10 \text{ W/m}^2 \cdot ^\circ\text{C})(1.649 \text{ m}^2)(34 - 20)^\circ\text{C} = \mathbf{231 \text{ W}}$$

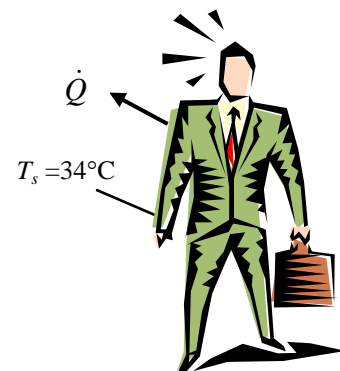

2-99 A spherical ball whose surface is maintained at a temperature of 110°C is suspended in the middle of a room at 20°C . The total rate of heat transfer from the ball is to be determined.

Assumptions 1 Steady operating conditions exist since the ball surface and the surrounding air and surfaces remain at constant temperatures. **2** The thermal properties of the ball and the convection heat transfer coefficient are constant and uniform.

Properties The emissivity of the ball surface is given to be $\varepsilon = 0.8$.

Analysis The heat transfer surface area is

$$A = \pi D^2 = \pi (0.09 \text{ m})^2 = 0.02545 \text{ m}^2$$

Under steady conditions, the rates of convection and radiation heat transfer are

$$\dot{Q}_{\text{conv}} = hA\Delta T = (15 \text{ W/m}^2 \cdot ^{\circ}\text{C})(0.02545 \text{ m}^2)(110 - 20)^{\circ}\text{C} = 34.35 \text{ W}$$

$$\dot{Q}_{\text{rad}} = \varepsilon\sigma A(T_s^4 - T_o^4) = 0.8(0.02545 \text{ m}^2)(5.67 \times 10^{-8} \text{ W/m}^2 \cdot \text{K}^4)[(383 \text{ K})^4 - (293 \text{ K})^4] = 16.33 \text{ W}$$

Therefore,

$$\dot{Q}_{\text{total}} = \dot{Q}_{\text{conv}} + \dot{Q}_{\text{rad}} = 34.35 + 16.33 = \mathbf{50.7 \text{ W}}$$

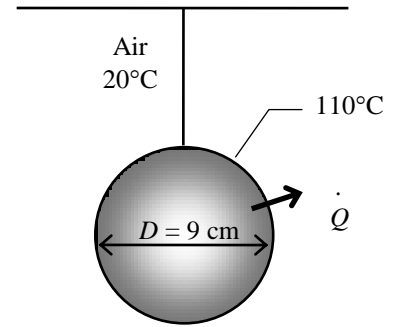



2-100 Reconsider Prob. 2-99. Using EES (or other) software, investigate the effect of the convection heat transfer coefficient and surface emissivity on the heat transfer rate from the ball. Let the heat transfer coefficient vary from $5 \text{ W/m}^2\cdot\text{C}$ to $30 \text{ W/m}^2\cdot\text{C}$. Plot the rate of heat transfer against the convection heat transfer coefficient for the surface emissivities of 0.1, 0.5, 0.8, and 1, and discuss the results.

Analysis The problem is solved using EES, and the solution is given below.

"Given"

$D=0.09 \text{ [m]}$
 $T_s=\text{ConvertTemp}(C,K,110)$
 $T_f=\text{ConvertTemp}(C,K,20)$
 $h=15 \text{ [W/m}^2\text{-C]}$
 $\text{epsilon}=0.8$

"Properties"

$\text{sigma}=5.67\text{E-}8 \text{ [W/m}^2\text{-K}^4]$

"Analysis"

$A=\text{pi}\cdot D^2$
 $Q_{\text{dot_conv}}=h\cdot A\cdot(T_s-T_f)$
 $Q_{\text{dot_rad}}=\text{epsilon}\cdot\text{sigma}\cdot A\cdot(T_s^4-T_f^4)$
 $Q_{\text{dot_total}}=Q_{\text{dot_conv}}+Q_{\text{dot_rad}}$

h [W/m ² -C]	Q _{total} [W]
5	27.8
7.5	33.53
10	39.25
12.5	44.98
15	50.7
17.5	56.43
20	62.16
22.5	67.88
25	73.61
27.5	79.33
30	85.06

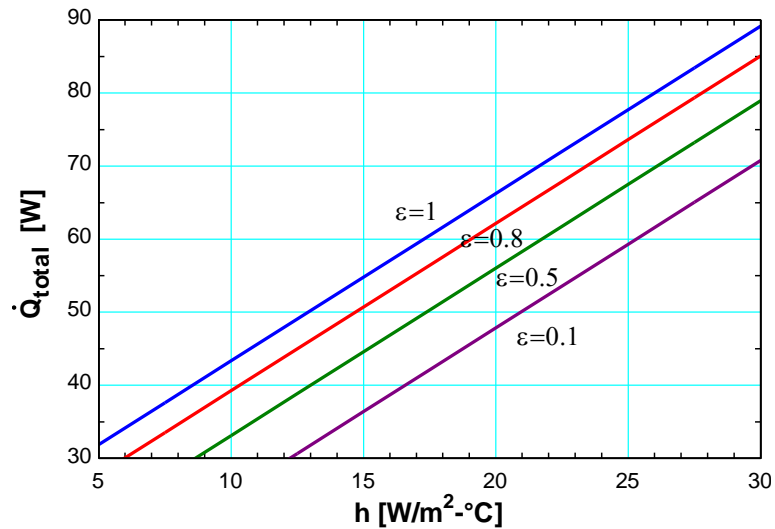

2-101 A 1000-W iron is left on the iron board with its base exposed to the air at 23°C. The temperature of the base of the iron is to be determined in steady operation.

Assumptions 1 Steady operating conditions exist. 2 The thermal properties of the iron base and the convection heat transfer coefficient are constant and uniform. 3 The temperature of the surrounding surfaces is the same as the temperature of the surrounding air.

Properties The emissivity of the base surface is given to be $\varepsilon = 0.4$.

Analysis At steady conditions, the 1000 W of energy supplied to the iron will be dissipated to the surroundings by convection and radiation heat transfer. Therefore,

$$\dot{Q}_{\text{total}} = \dot{Q}_{\text{conv}} + \dot{Q}_{\text{rad}} = 1000 \text{ W}$$

where

$$\dot{Q}_{\text{conv}} = hA\Delta T = (20 \text{ W/m}^2 \cdot \text{K})(0.02 \text{ m}^2)(T_s - 296 \text{ K}) = 0.4(T_s - 296 \text{ K}) \text{ W}$$

and

$$\begin{aligned} \dot{Q}_{\text{rad}} &= \varepsilon\sigma A(T_s^4 - T_o^4) = 0.4(0.02 \text{ m}^2)(5.67 \times 10^{-8} \text{ W/m}^2 \cdot \text{K}^4)[T_s^4 - (296 \text{ K})^4] \\ &= 0.04536 \times 10^{-8} [T_s^4 - (296 \text{ K})^4] \text{ W} \end{aligned}$$

Substituting,

$$1000 \text{ W} = 0.4(T_s - 296 \text{ K}) + 0.04536 \times 10^{-8} [T_s^4 - (296 \text{ K})^4]$$

Solving by trial and error gives

$$T_s = 1106 \text{ K} = \mathbf{833^\circ\text{C}}$$

Discussion We note that the iron will dissipate all the energy it receives by convection and radiation when its surface temperature reaches 1106 K.

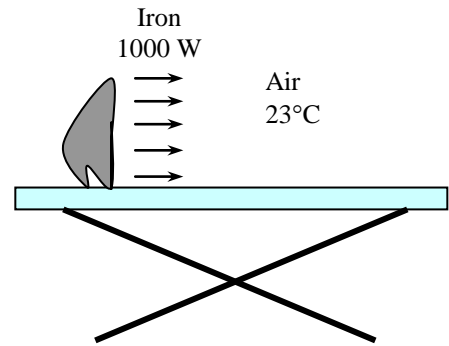

2-102 A hot water pipe at 80°C is losing heat to the surrounding air at 5°C by natural convection with a heat transfer coefficient of 25 W/m²·°C. The rate of heat loss from the pipe by convection is to be determined.

Assumptions 1 Steady operating conditions exist. 2 Heat transfer by radiation is not considered. 3 The convection heat transfer coefficient is constant and uniform over the surface.

Analysis The heat transfer surface area is

$$A = (\pi D)L = \pi(0.07 \text{ m})(18 \text{ m}) = 3.958 \text{ m}^2$$

Under steady conditions, the rate of heat transfer by convection is

$$\dot{Q}_{\text{conv}} = hA\Delta T = (25 \text{ W/m}^2 \cdot ^\circ\text{C})(3.958 \text{ m}^2)(80 - 5)^\circ\text{C} = 7422 \text{ W} = \mathbf{7.42 \text{ kW}}$$

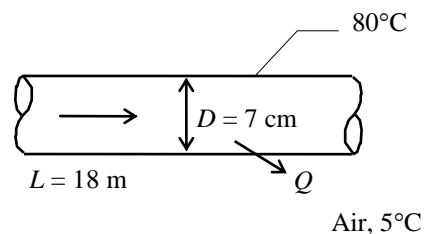

2-103 The backside of the thin metal plate is insulated and the front side is exposed to solar radiation. The surface temperature of the plate is to be determined when it stabilizes.

Assumptions **1** Steady operating conditions exist. **2** Heat transfer through the insulated side of the plate is negligible. **3** The heat transfer coefficient is constant and uniform over the plate. **4** Heat loss by radiation is negligible.

Properties The solar absorptivity of the plate is given to be $\alpha = 0.8$.

Analysis When the heat loss from the plate by convection equals the solar radiation absorbed, the surface temperature of the plate can be determined from

$$\begin{aligned}\dot{Q}_{\text{solarabsorbed}} &= \dot{Q}_{\text{conv}} \\ \alpha \dot{Q}_{\text{solar}} &= hA(T_s - T_o) \\ 0.8 \times A \times 450 \text{ W/m}^2 &= (50 \text{ W/m}^2 \cdot \text{°C})A(T_s - 25)\end{aligned}$$

Canceling the surface area A and solving for T_s gives

$$T_s = \mathbf{32.2^\circ\text{C}}$$

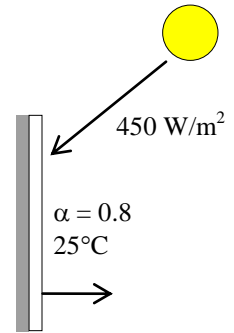



2-104 Reconsider Prob. 2-103. Using EES (or other) software, investigate the effect of the convection heat transfer coefficient on the surface temperature of the plate. Let the heat transfer coefficient vary from $10 \text{ W/m}^2\cdot\text{C}$ to $90 \text{ W/m}^2\cdot\text{C}$. Plot the surface temperature against the convection heat transfer coefficient, and discuss the results.

Analysis The problem is solved using EES, and the solution is given below.

"Given"

alpha=0.8
 q_dot_solar=450 [W/m^2]
 T_f=25 [C]
 h=50 [W/m^2-C]

"Analysis"

q_dot_solarabsorbed=alpha*q_dot_solar
 q_dot_conv=h*(T_s-T_f)
 q_dot_solarabsorbed=q_dot_conv

h [W/m ² -C]	T _s [C]
10	61
15	49
20	43
25	39.4
30	37
35	35.29
40	34
45	33
50	32.2
55	31.55
60	31
65	30.54
70	30.14
75	29.8
80	29.5
85	29.24
90	29

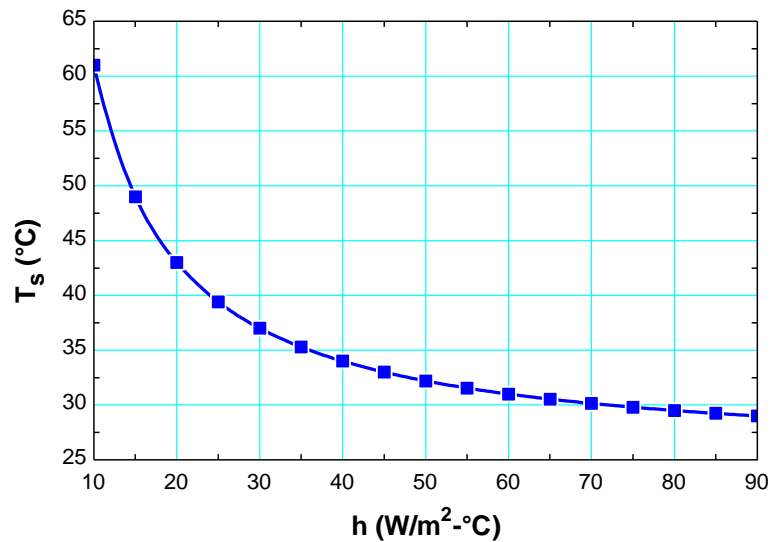

2-105 A spacecraft in space absorbs solar radiation while losing heat to deep space by thermal radiation. The surface temperature of the spacecraft is to be determined when steady conditions are reached..

Assumptions **1** Steady operating conditions exist since the surface temperatures of the wall remain constant at the specified values. **2** Thermal properties of the spacecraft are constant.

Properties The outer surface of a spacecraft has an emissivity of 0.6 and an absorptivity of 0.2.

Analysis When the heat loss from the outer surface of the spacecraft by radiation equals the solar radiation absorbed, the surface temperature can be determined from

$$\begin{aligned}\dot{Q}_{\text{solarabsorbed}} &= \dot{Q}_{\text{rad}} \\ \alpha \dot{Q}_{\text{solar}} &= \varepsilon \sigma A (T_s^4 - T_{\text{space}}^4) \\ 0.2 \times A \times (1000 \text{ W/m}^2) &= 0.6 \times A \times (5.67 \times 10^{-8} \text{ W/m}^2 \cdot \text{K}^4) [T_s^4 - (0 \text{ K})^4]\end{aligned}$$

Canceling the surface area A and solving for T_s gives

$$T_s = \mathbf{276.9\text{K}}$$

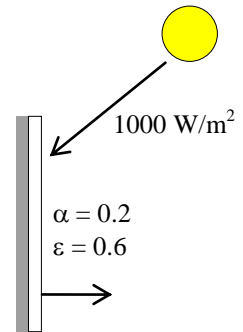



2-106 Reconsider Prob. 2-105. Using EES (or other) software, investigate the effect of the surface emissivity and absorptivity of the spacecraft on the equilibrium surface temperature. Plot the surface temperature against emissivity for solar absorptivities of 0.1, 0.5, 0.8, and 1, and discuss the results.

Analysis The problem is solved using EES, and the solution is given below.

"Given"

epsilon=0.2
 alpha=0.6
 q_dot_solar=1000 [W/m^2]
 T_f=0 [K] "space temperature"

"Properties"

sigma=5.67E-8 [W/m^2-K^4]

"Analysis"

q_dot_solarabsorbed=alpha*q_dot_solar
 q_dot_rad=epsilon*sigma*(T_s^4-T_f^4)
 q_dot_solarabsorbed=q_dot_rad

ϵ	T_s [K]
0.1	648
0.2	544.9
0.3	492.4
0.4	458.2
0.5	433.4
0.6	414.1
0.7	398.4
0.8	385.3
0.9	374.1
1	364.4

Table for $\epsilon = 1$

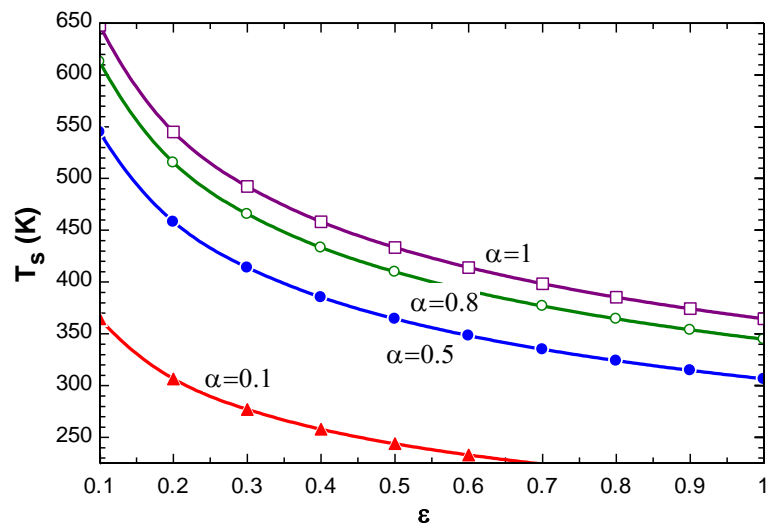

2-107 A hollow spherical iron container is filled with iced water at 0°C . The rate of heat loss from the sphere and the rate at which ice melts in the container are to be determined.

Assumptions **1** Steady operating conditions exist since the surface temperatures of the wall remain constant at the specified values. **2** Heat transfer through the shell is one-dimensional. **3** Thermal properties of the iron shell are constant. **4** The inner surface of the shell is at the same temperature as the iced water, 0°C .

Properties The thermal conductivity of iron is $k = 80.2 \text{ W/m}\cdot^{\circ}\text{C}$ (Table 2-3). The heat of fusion of water is at 1 atm is 333.7 kJ/kg .

Analysis This spherical shell can be approximated as a plate of thickness 0.4 cm and surface area

$$A = \pi D^2 = \pi (0.4 \text{ m})^2 = 0.5027 \text{ m}^2$$

Then the rate of heat transfer through the shell by conduction is

$$\dot{Q}_{\text{cond}} = kA \frac{\Delta T}{L} = (80.2 \text{ W/m}\cdot^{\circ}\text{C})(0.5027 \text{ m}^2) \frac{(3 - 0)^{\circ}\text{C}}{0.004 \text{ m}} = \mathbf{30,235 \text{ W}}$$

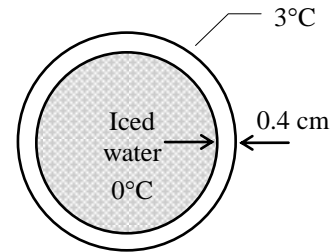

Considering that it takes 333.7 kJ of energy to melt 1 kg of ice at 0°C , the rate at which ice melts in the container can be determined from

$$\dot{m}_{\text{ice}} = \frac{\dot{Q}}{h_{if}} = \frac{30.235 \text{ kJ/s}}{333.7 \text{ kJ/kg}} = \mathbf{0.0906 \text{ kg/s}}$$

Discussion We should point out that this result is slightly in error for approximating a curved wall as a plain wall. The error in this case is very small because of the large diameter to thickness ratio. For better accuracy, we could use the inner surface area ($D = 39.2 \text{ cm}$) or the mean surface area ($D = 39.6 \text{ cm}$) in the calculations.

Review Problems

2-108 The weight of the cabin of an elevator is balanced by a counterweight. The power needed when the fully loaded cabin is rising, and when the empty cabin is descending at a constant speed are to be determined.

Assumptions **1** The weight of the cables is negligible. **2** The guide rails and pulleys are frictionless. **3** Air drag is negligible.

Analysis (a) When the cabin is fully loaded, half of the weight is balanced by the counterweight. The power required to raise the cabin at a constant speed of 1.2 m/s is

$$\dot{W} = \frac{mgz}{\Delta t} = mgV = (400 \text{ kg})(9.81 \text{ m/s}^2)(1.2 \text{ m/s}) \left(\frac{1 \text{ N}}{1 \text{ kg} \cdot \text{m/s}^2} \right) \left(\frac{1 \text{ kW}}{1000 \text{ N} \cdot \text{m/s}} \right) = \mathbf{4.71 \text{ kW}}$$

If no counterweight is used, the mass would double to 800 kg and the power would be $2 \times 4.71 = \mathbf{9.42 \text{ kW}}$.

(b) When the empty cabin is descending (and the counterweight is ascending) there is mass imbalance of $400 - 150 = 250 \text{ kg}$. The power required to raise this mass at a constant speed of 1.2 m/s is

$$\dot{W} = \frac{mgz}{\Delta t} = mgV = (250 \text{ kg})(9.81 \text{ m/s}^2)(1.2 \text{ m/s}) \left(\frac{1 \text{ N}}{1 \text{ kg} \cdot \text{m/s}^2} \right) \left(\frac{1 \text{ kW}}{1000 \text{ N} \cdot \text{m/s}} \right) = \mathbf{2.94 \text{ kW}}$$

If a friction force of 800 N develops between the cabin and the guide rails, we will need

$$\dot{W}_{\text{friction}} = \frac{F_{\text{friction}}z}{\Delta t} = F_{\text{friction}}V = (800 \text{ N})(1.2 \text{ m/s}) \left(\frac{1 \text{ kW}}{1000 \text{ N} \cdot \text{m/s}} \right) = 0.96 \text{ kW}$$

of additional power to combat friction which always acts in the opposite direction to motion. Therefore, the total power needed in this case is

$$\dot{W}_{\text{total}} = \dot{W} + \dot{W}_{\text{friction}} = 2.94 + 0.96 = \mathbf{3.90 \text{ kW}}$$

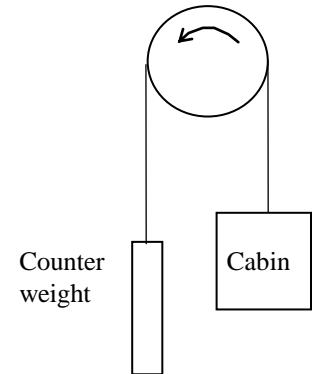

2-109 A decision is to be made between a cheaper but inefficient natural gas heater and an expensive but efficient natural gas heater for a house.

Assumptions The two heaters are comparable in all aspects other than the initial cost and efficiency.

Analysis Other things being equal, the logical choice is the heater that will cost less during its lifetime. The total cost of a system during its lifetime (the initial, operation, maintenance, etc.) can be determined by performing a life cycle cost analysis. A simpler alternative is to determine the simple payback period.

The annual heating cost is given to be \$1200. Noting that the existing heater is 55% efficient, only 55% of that energy (and thus money) is delivered to the house, and the rest is wasted due to the inefficiency of the heater. Therefore, the monetary value of the heating load of the house is

$$\begin{aligned}\text{Cost of useful heat} &= (55\%)(\text{Current annual heating cost}) \\ &= 0.55 \times (\$1200/\text{yr}) = \$660/\text{yr}\end{aligned}$$

Gas Heater $\eta_1 = 82\%$ $\eta_2 = 95\%$
--

This is how much it would cost to heat this house with a heater that is 100% efficient. For heaters that are less efficient, the annual heating cost is determined by dividing \$660 by the efficiency:

82% heater: Annual cost of heating = (Cost of useful heat)/Efficiency = $(\$660/\text{yr})/0.82 = \$805/\text{yr}$

95% heater: Annual cost of heating = (Cost of useful heat)/Efficiency = $(\$660/\text{yr})/0.95 = \$695/\text{yr}$

$$\text{Annual cost savings with the efficient heater} = 805 - 695 = \$110$$

$$\text{Excess initial cost of the efficient heater} = 2700 - 1600 = \$1100$$

The simple payback period becomes

$$\text{Simple payback period} = \frac{\text{Excess initial cost}}{\text{Annual cost savings}} = \frac{\$1100}{\$110/\text{yr}} = \mathbf{10 \text{ years}}$$

Therefore, the more efficient heater will pay for the \$1100 cost differential in this case in 10 years, which is more than the 8-year limit. Therefore, the purchase of the cheaper and less efficient heater is a better buy in this case.

2-110E The energy contents, unit costs, and typical conversion efficiencies of various energy sources for use in water heaters are given. The lowest cost energy source is to be determined.

Assumptions The differences in installation costs of different water heaters are not considered.

Properties The energy contents, unit costs, and typical conversion efficiencies of different systems are given in the problem statement.

Analysis The unit cost of each Btu of useful energy supplied to the water heater by each system can be determined from

$$\text{Unit cost of useful energy} = \frac{\text{Unit cost of energy supplied}}{\text{Conversion efficiency}}$$

Substituting,

$$\text{Natural gas heater:} \quad \text{Unit cost of useful energy} = \frac{\$0.012/\text{ft}^3}{0.85} \left(\frac{1 \text{ ft}^3}{1025 \text{ Btu}} \right) = \$13.8 \times 10^{-6} / \text{Btu}$$

$$\text{Heating by oil heater:} \quad \text{Unit cost of useful energy} = \frac{\$2.2/\text{gal}}{0.75} \left(\frac{1 \text{ gal}}{138,700 \text{ Btu}} \right) = \$21.1 \times 10^{-6} / \text{Btu}$$

$$\text{Electric heater:} \quad \text{Unit cost of useful energy} = \frac{\$0.11/\text{kWh}}{0.90} \left(\frac{1 \text{ kWh}}{3412 \text{ Btu}} \right) = \$35.8 \times 10^{-6} / \text{Btu}$$

Therefore, the lowest cost energy source for hot water heaters in this case is **natural gas**.

2-111 A home owner is considering three different heating systems for heating his house. The system with the lowest energy cost is to be determined.

Assumptions The differences in installation costs of different heating systems are not considered.

Properties The energy contents, unit costs, and typical conversion efficiencies of different systems are given in the problem statement.

Analysis The unit cost of each Btu of useful energy supplied to the house by each system can be determined from

$$\text{Unit cost of useful energy} = \frac{\text{Unit cost of energy supplied}}{\text{Conversion efficiency}}$$

Substituting,

$$\text{Natural gas heater:} \quad \text{Unit cost of useful energy} = \frac{\$1.24/\text{therm}}{0.87} \left(\frac{1 \text{ therm}}{105,500 \text{ kJ}} \right) = \$13.5 \times 10^{-6} / \text{kJ}$$

$$\text{Heating oil heater:} \quad \text{Unit cost of useful energy} = \frac{\$2.3/\text{gal}}{0.87} \left(\frac{1 \text{ gal}}{138,500 \text{ kJ}} \right) = \$19.1 \times 10^{-6} / \text{kJ}$$

$$\text{Electric heater:} \quad \text{Unit cost of useful energy} = \frac{\$0.12/\text{kWh}}{1.0} \left(\frac{1 \text{ kWh}}{3600 \text{ kJ}} \right) = \$33.3 \times 10^{-6} / \text{kJ}$$

Therefore, the system with the lowest energy cost for heating the house is the **natural gas heater**.

2-112 It is estimated that 570,000 barrels of oil would be saved per day if the thermostat setting in residences in winter were lowered by 6°F (3.3°C). The amount of money that would be saved per year is to be determined.

Assumptions The average heating season is given to be 180 days, and the cost of oil to be \$40/barrel.

Analysis The amount of money that would be saved per year is determined directly from

$$(570,000 \text{ barrel/day})(180 \text{ days/year})(\$110/\text{barrel}) = \mathbf{\$11,290,000,000}$$

Therefore, the proposed measure will save more than 11-billion dollars a year in energy costs.

2-113 Caulking and weather-stripping doors and windows to reduce air leaks can reduce the energy use of a house by up to 10 percent. The time it will take for the caulking and weather-stripping to pay for itself from the energy it saves is to be determined.

Assumptions It is given that the annual energy usage of a house is \$1100 a year, and the cost of caulking and weather-stripping a house is \$90.

Analysis The amount of money that would be saved per year is determined directly from

$$\text{Money saved} = (\$1100/\text{year})(0.10) = \$110/\text{yr}$$

Then the simple payback period becomes

$$\text{Payback period} = \frac{\text{Cost}}{\text{Money saved}} = \frac{\$90}{\$110/\text{yr}} = \mathbf{0.818 \text{ yr}}$$

Therefore, the proposed measure will pay for itself in less than a year.

2-114E The work required to compress a gas in a gas spring is to be determined.

Assumptions All forces except that generated by the gas spring will be neglected.

Analysis When the expression given in the problem statement is substituted into the work integral relation, and advantage is taken of the fact that the force and displacement vectors are collinear, the result is

$$\begin{aligned} W &= \int_1^2 F ds = \int_1^2 \frac{\text{Constant}}{x^k} dx \\ &= \frac{\text{Constant}}{1-k} (x_2^{1-k} - x_1^{1-k}) \\ &= \frac{200 \text{ lbf} \cdot \text{in}^{1.4}}{1-1.4} \left[(7 \text{ in})^{-0.4} - (2 \text{ in})^{-0.4} \right] \left(\frac{1 \text{ ft}}{12 \text{ in}} \right) \\ &= 12.45 \text{ lbf} \cdot \text{ft} \\ &= (12.45 \text{ lbf} \cdot \text{ft}) \left(\frac{1 \text{ Btu}}{778.169 \text{ lbf} \cdot \text{ft}} \right) = \mathbf{0.0160 \text{ Btu}} \end{aligned}$$

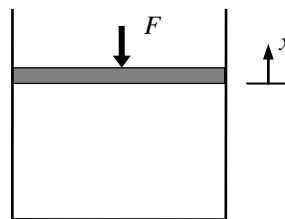

2-115E A man pushes a block along a horizontal plane. The work required to move the block is to be determined considering (a) the man and (b) the block as the system.

Analysis The work applied to the block to overcome the friction is found by using the work integral,

$$\begin{aligned} W &= \int_1^2 F ds = \int_1^2 fW(x_2 - x_1) \\ &= (0.2)(100 \text{ lbf})(100 \text{ ft}) \\ &= 2000 \text{ lbf} \cdot \text{ft} \\ &= (2000 \text{ lbf} \cdot \text{ft}) \left(\frac{1 \text{ Btu}}{778.169 \text{ lbf} \cdot \text{ft}} \right) = \mathbf{2.57 \text{ Btu}} \end{aligned}$$

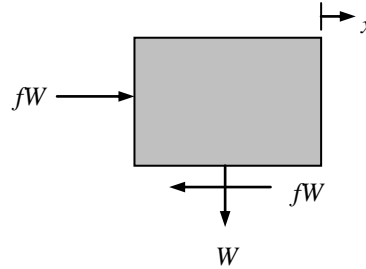

The man must then produce the amount of work

$$W = \mathbf{2.57 \text{ Btu}}$$

2-116 A diesel engine burning light diesel fuel that contains sulfur is considered. The rate of sulfur that ends up in the exhaust and the rate of sulfuric acid given off to the environment are to be determined.

Assumptions **1** All of the sulfur in the fuel ends up in the exhaust. **2** For one kmol of sulfur in the exhaust, one kmol of sulfuric acid is added to the environment.

Properties The molar mass of sulfur is 32 kg/kmol.

Analysis The mass flow rates of fuel and the sulfur in the exhaust are

$$\begin{aligned} \dot{m}_{\text{fuel}} &= \frac{\dot{m}_{\text{air}}}{\text{AF}} = \frac{(336 \text{ kg air/h})}{(18 \text{ kg air/kg fuel})} = 18.67 \text{ kg fuel/h} \\ \dot{m}_{\text{Sulfur}} &= (750 \times 10^{-6}) \dot{m}_{\text{fuel}} = (750 \times 10^{-6})(18.67 \text{ kg/h}) = \mathbf{0.014 \text{ kg/h}} \end{aligned}$$

The rate of sulfuric acid given off to the environment is

$$\dot{m}_{\text{H}_2\text{SO}_3} = \frac{M_{\text{H}_2\text{SO}_3}}{M_{\text{Sulfur}}} \dot{m}_{\text{Sulfur}} = \frac{2 \times 1 + 32 + 3 \times 16}{32} (0.014 \text{ kg/h}) = \mathbf{0.036 \text{ kg/h}}$$

Discussion This problem shows why the sulfur percentage in diesel fuel must be below certain value to satisfy regulations.

2-117 Lead is a very toxic engine emission. Leaded gasoline contains lead that ends up in the exhaust. The amount of lead put out to the atmosphere per year for a given city is to be determined.

Assumptions Entire lead is exhausted to the environment.

Analysis The gasoline consumption and the lead emission are

$$\begin{aligned} \text{Gasoline Consumption} &= (70,000 \text{ cars})(15,000 \text{ km/car} \cdot \text{year})(8.5 \text{ L}/100 \text{ km}) = 8.925 \times 10^7 \text{ L/year} \\ \text{Lead Emission} &= (\text{Gasoline Consumption}) m_{\text{lead}} f_{\text{lead}} \\ &= (8.925 \times 10^7 \text{ L/year})(0.15 \times 10^{-3} \text{ kg/L})(0.50) \\ &= \mathbf{6694 \text{ kg/year}} \end{aligned}$$

Discussion Note that a huge amounts of lead emission is avoided by the use of unleaded gasoline.

2-118 A TV set is kept on a specified number of hours per day. The cost of electricity this TV set consumes per month is to be determined.

Assumptions 1 The month is 30 days. **2** The TV set consumes its rated power when on.

Analysis The total number of hours the TV is on per month is

$$\text{Operating hours} = (6 \text{ h/day})(30 \text{ days}) = 180 \text{ h}$$

Then the amount of electricity consumed per month and its cost become

$$\text{Amount of electricity} = (\text{Power consumed})(\text{Operating hours}) = (0.120 \text{ kW})(180 \text{ h}) = 21.6 \text{ kWh}$$

$$\text{Cost of electricity} = (\text{Amount of electricity})(\text{Unit cost}) = (21.6 \text{ kWh})(\$0.12/\text{kWh}) = \mathbf{\$2.59} \text{ (per month)}$$

Properties Note that an ordinary TV consumes more electricity than a large light bulb, and there should be a conscious effort to turn it off when not in use to save energy.

2-119E The power required to pump a specified rate of water to a specified elevation is to be determined.

Properties The density of water is taken to be 62.4 lbf/ft^3 (Table A-3E).

Analysis The required power is determined from

$$\begin{aligned} \dot{W} &= \dot{m}g(z_2 - z_1) = \rho \dot{V}g(z_2 - z_1) \\ &= (62.4 \text{ lbf/ft}^3)(200 \text{ gal/min}) \left(\frac{35.315 \text{ ft}^3/\text{s}}{15,850 \text{ gal/min}} \right) (32.174 \text{ ft/s}^2)(300 \text{ ft}) \left(\frac{1 \text{ lbf}}{32.174 \text{ lbf} \cdot \text{ft/s}^2} \right) \\ &= 8342 \text{ lbf} \cdot \text{ft/s} = (8342 \text{ lbf} \cdot \text{ft/s}) \left(\frac{1 \text{ kW}}{737.56 \text{ lbf} \cdot \text{ft/s}} \right) = \mathbf{11.3 \text{ kW}} \end{aligned}$$

2-120 The power that could be produced by a water wheel is to be determined.

Properties The density of water is taken to be 1000 kg/m^3 (Table A-3).

Analysis The power production is determined from

$$\begin{aligned} \dot{W} &= \dot{m}g(z_2 - z_1) = \rho \dot{V}g(z_2 - z_1) \\ &= (1000 \text{ kg/m}^3)(0.320/60 \text{ m}^3/\text{s})(9.81 \text{ m/s}^2)(14 \text{ m}) \left(\frac{1 \text{ kJ/kg}}{1000 \text{ m}^2/\text{s}^2} \right) = \mathbf{0.732 \text{ kW}} \end{aligned}$$

2-121 The flow of air through a flow channel is considered. The diameter of the wind channel downstream from the rotor and the power produced by the windmill are to be determined.

Analysis The specific volume of the air is

$$\nu = \frac{RT}{P} = \frac{(0.287 \text{ kPa} \cdot \text{m}^3/\text{kg} \cdot \text{K})(293 \text{ K})}{100 \text{ kPa}} = 0.8409 \text{ m}^3/\text{kg}$$

The diameter of the wind channel downstream from the rotor is

$$\begin{aligned} A_1 V_1 &= A_2 V_2 \longrightarrow (\pi D_1^2 / 4) V_1 = (\pi D_2^2 / 4) V_2 \\ \longrightarrow D_2 &= D_1 \sqrt{\frac{V_1}{V_2}} = (7 \text{ m}) \sqrt{\frac{8 \text{ m/s}}{6.5 \text{ m/s}}} = \mathbf{7.77 \text{ m}} \end{aligned}$$

The mass flow rate through the wind mill is

$$\dot{m} = \frac{A_1 V_1}{\nu} = \frac{\pi (7 \text{ m})^2 (8 \text{ m/s})}{4(0.8409 \text{ m}^3/\text{kg})} = 366.1 \text{ kg/s}$$

The power produced is then

$$\dot{W} = \dot{m} \frac{V_1^2 - V_2^2}{2} = (366.1 \text{ kg/s}) \frac{(8 \text{ m/s})^2 - (6.5 \text{ m/s})^2}{2} \left(\frac{1 \text{ kJ/kg}}{1000 \text{ m}^2/\text{s}^2} \right) = \mathbf{3.98 \text{ kW}}$$

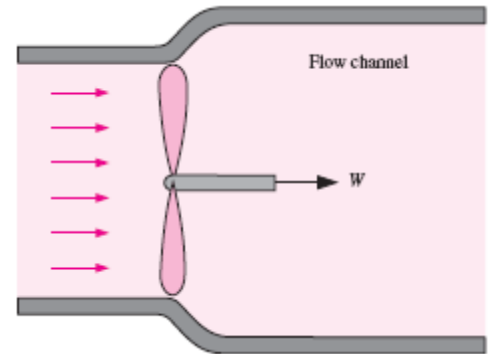

2-122 The available head, flow rate, and efficiency of a hydroelectric turbine are given. The electric power output is to be determined.

Assumptions 1 The flow is steady. **2** Water levels at the reservoir and the discharge site remain constant. **3** Frictional losses in piping are negligible.

Properties We take the density of water to be $\rho = 1000 \text{ kg/m}^3 = 1 \text{ kg/L}$.

Analysis The total mechanical energy the water in a dam possesses is equivalent to the potential energy of water at the free surface of the dam (relative to free surface of discharge water), and it can be converted to work entirely. Therefore, the power potential of water is its potential energy, which is gz per unit mass, and $\dot{m}gz$ for a given mass flow rate.

$$e_{\text{mech}} = pe = gz = (9.81 \text{ m/s}^2)(90 \text{ m}) \left(\frac{1 \text{ kJ/kg}}{1000 \text{ m}^2/\text{s}^2} \right) = 0.8829 \text{ kJ/kg}$$

The mass flow rate is

$$\dot{m} = \rho \dot{V} = (1000 \text{ kg/m}^3)(65 \text{ m}^3/\text{s}) = 65,000 \text{ kg/s}$$

Then the maximum and actual electric power generation become

$$\dot{W}_{\text{max}} = \dot{E}_{\text{mech}} = \dot{m} e_{\text{mech}} = (65,000 \text{ kg/s})(0.8829 \text{ kJ/kg}) \left(\frac{1 \text{ MW}}{1000 \text{ kJ/s}} \right) = 57.39 \text{ MW}$$

$$\dot{W}_{\text{electric}} = \eta_{\text{overall}} \dot{W}_{\text{max}} = 0.84(57.39 \text{ MW}) = \mathbf{48.2 \text{ MW}}$$

Discussion Note that the power generation would increase by more than 1 MW for each percentage point improvement in the efficiency of the turbine-generator unit.

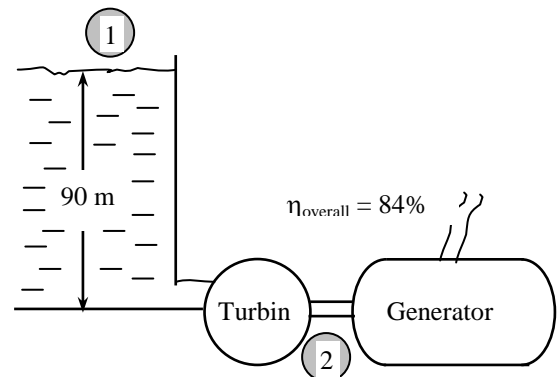

2-123 An entrepreneur is to build a large reservoir above the lake level, and pump water from the lake to the reservoir at night using cheap power, and let the water flow from the reservoir back to the lake during the day, producing power. The potential revenue this system can generate per year is to be determined.

Assumptions **1** The flow in each direction is steady and incompressible. **2** The elevation difference between the lake and the reservoir can be taken to be constant, and the elevation change of reservoir during charging and discharging is disregarded. **3** Frictional losses in piping are negligible. **4** The system operates every day of the year for 10 hours in each mode.

Properties We take the density of water to be $\rho = 1000 \text{ kg/m}^3$.

Analysis The total mechanical energy of water in an upper reservoir relative to water in a lower reservoir is equivalent to the potential energy of water at the free surface of this reservoir relative to free surface of the lower reservoir. Therefore, the power potential of water is its potential energy, which is gz per unit mass, and $\dot{m}gz$ for a given mass flow rate. This also represents the minimum power required to pump water from the lower reservoir to the higher reservoir.

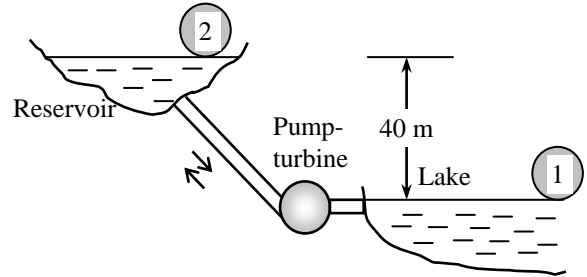

$$\begin{aligned}\dot{W}_{\max, \text{turbine}} = \dot{W}_{\min, \text{pump}} = \dot{W}_{\text{ideal}} &= \Delta \dot{E}_{\text{mech}} = \dot{m} \Delta e_{\text{mech}} = \dot{m} \Delta pe = \dot{m} g \Delta z = \rho \dot{V} g \Delta z \\ &= (1000 \text{ kg/m}^3)(2 \text{ m}^3/\text{s})(9.81 \text{ m/s}^2)(40 \text{ m}) \left(\frac{1 \text{ N}}{1 \text{ kg} \cdot \text{m/s}^2} \right) \left(\frac{1 \text{ kW}}{1000 \text{ N} \cdot \text{m/s}} \right) \\ &= 784.8 \text{ kW}\end{aligned}$$

The actual pump and turbine electric powers are

$$\dot{W}_{\text{pump, elect}} = \frac{\dot{W}_{\text{ideal}}}{\eta_{\text{pump-motor}}} = \frac{784.8 \text{ kW}}{0.75} = 1046 \text{ kW}$$

$$\dot{W}_{\text{turbine}} = \eta_{\text{turbine-gen}} \dot{W}_{\text{ideal}} = 0.75(784.8 \text{ kW}) = 588.6 \text{ kW}$$

Then the power consumption cost of the pump, the revenue generated by the turbine, and the net income (revenue minus cost) per year become

$$\text{Cost} = \dot{W}_{\text{pump, elect}} \Delta t \times \text{Unit price} = (1046 \text{ kW})(365 \times 10 \text{ h/year})(\$0.05/\text{kWh}) = \$190,968/\text{year}$$

$$\text{Revenue} = \dot{W}_{\text{turbine}} \Delta t \times \text{Unit price} = (588.6 \text{ kW})(365 \times 10 \text{ h/year})(\$0.12/\text{kWh}) = \$257,807/\text{year}$$

$$\text{Net income} = \text{Revenue} - \text{Cost} = 257,807 - 190,968 = \mathbf{\$66,839/\text{year}}$$

Discussion It appears that this pump-turbine system has a potential to generate net revenues of about \$67,000 per year. A decision on such a system will depend on the initial cost of the system, its life, the operating and maintenance costs, the interest rate, and the length of the contract period, among other things.

2-124 The pump of a water distribution system is pumping water at a specified flow rate. The pressure rise of water in the pump is measured, and the motor efficiency is specified. The mechanical efficiency of the pump is to be determined.

Assumptions 1 The flow is steady. 2 The elevation difference across the pump is negligible. 3 Water is incompressible.

Analysis From the definition of motor efficiency, the mechanical (shaft) power delivered by the motor is

$$\dot{W}_{\text{pump,shaft}} = \eta_{\text{motor}} \dot{W}_{\text{electric}} = (0.90)(15 \text{ kW}) = 13.5 \text{ kW}$$

To determine the mechanical efficiency of the pump, we need to know the increase in the mechanical energy of the fluid as it flows through the pump, which is

$$\begin{aligned} \Delta \dot{E}_{\text{mech,fluid}} &= \dot{m}(e_{\text{mech,out}} - e_{\text{mech,in}}) = \dot{m}[(Pv)_2 - (Pv)_1] = \dot{m}(P_2 - P_1)v = \dot{V}(P_2 - P_1) \\ &= (0.050 \text{ m}^3/\text{s})(300 - 100 \text{ kPa}) \left(\frac{1 \text{ kJ}}{1 \text{ kPa} \cdot \text{m}^3} \right) = 10 \text{ kJ/s} = 10 \text{ kW} \end{aligned}$$

since $\dot{m} = \rho \dot{V} = \dot{V}/v$ and there is no change in kinetic and potential energies of the fluid. Then the pump efficiency becomes

$$\eta_{\text{pump}} = \frac{\Delta \dot{E}_{\text{mech,fluid}}}{\dot{W}_{\text{pump,shaft}}} = \frac{10 \text{ kW}}{13.5 \text{ kW}} = 0.741 \text{ or } \mathbf{74.1\%}$$

Discussion The overall efficiency of this pump/motor unit is the product of the mechanical and motor efficiencies, which is $0.9 \times 0.741 = 0.667$.

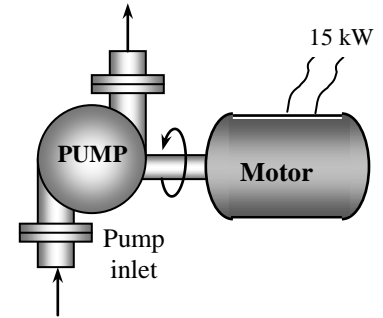

Fundamentals of Engineering (FE) Exam Problems

2-125 In a hot summer day, the air in a well-sealed room is circulated by a 0.50-hp (shaft) fan driven by a 65% efficient motor. (Note that the motor delivers 0.50 hp of net shaft power to the fan). The rate of energy supply from the fan-motor assembly to the room is

- (a) 0.769 kJ/s (b) 0.325 kJ/s (c) 0.574 kJ/s (d) 0.373 kJ/s (e) 0.242 kJ/s

Answer (c) 0.574 kJ/s

Solution Solved by EES Software. Solutions can be verified by copying-and-pasting the following lines on a blank EES screen. (Similar problems and their solutions can be obtained easily by modifying numerical values).

Eff=0.65

W_fan=0.50*0.7457 "kW"

E=W_fan/Eff "kJ/s"

"Some Wrong Solutions with Common Mistakes:"

W1_E=W_fan*Eff "Multiplying by efficiency"

W2_E=W_fan "Ignoring efficiency"

W3_E=W_fan/Eff/0.7457 "Using hp instead of kW"

2-126 A fan is to accelerate quiescent air to a velocity to 12 m/s at a rate of 3 m³/min. If the density of air is 1.15 kg/m³, the minimum power that must be supplied to the fan is

- (a) 248 W (b) 72 W (c) 497 W (d) 216 W (e) 162 W

Answer (a) 248 W

Solution Solved by EES Software. Solutions can be verified by copying-and-pasting the following lines on a blank EES screen. (Similar problems and their solutions can be obtained easily by modifying numerical values).

rho=1.15

V=12

Vdot=3 "m3/s"

mdot=rho*Vdot "kg/s"

We=mdot*V^2/2

"Some Wrong Solutions with Common Mistakes:"

W1_We=Vdot*V^2/2 "Using volume flow rate"

W2_We=mdot*V^2 "forgetting the 2"

W3_We=V^2/2 "not using mass flow rate"

2-127 A 2-kW electric resistance heater in a room is turned on and kept on for 50 min. The amount of energy transferred to the room by the heater is

- (a) 2 kJ (b) 100 kJ (c) 3000 kJ (d) 6000 kJ (e) 12,000 kJ

Answer (d) 6000 kJ

Solution Solved by EES Software. Solutions can be verified by copying-and-pasting the following lines on a blank EES screen. (Similar problems and their solutions can be obtained easily by modifying numerical values).

```
We= 2 "kJ/s"
time=50*60 "s"
We_total=We*time "kJ"
"Some Wrong Solutions with Common Mistakes:"
W1_Etotal=We*time/60 "using minutes instead of s"
W2_Etotal=We "ignoring time"
```

2-128 A 900-kg car cruising at a constant speed of 60 km/h is to accelerate to 100 km/h in 4 s. The additional power needed to achieve this acceleration is

- (a) 56 kW (b) 222 kW (c) 2.5 kW (d) 62 kW (e) 90 kW

Answer (a) 56 kW

Solution Solved by EES Software. Solutions can be verified by copying-and-pasting the following lines on a blank EES screen. (Similar problems and their solutions can be obtained easily by modifying numerical values).

```
m=900 "kg"
V1=60 "km/h"
V2=100 "km/h"
Dt=4 "s"
Wa=m*((V2/3.6)^2-(V1/3.6)^2)/2000/Dt "kW"
"Some Wrong Solutions with Common Mistakes:"
W1_Wa=((V2/3.6)^2-(V1/3.6)^2)/2/Dt "Not using mass"
W2_Wa=m*((V2)^2-(V1)^2)/2000/Dt "Not using conversion factor"
W3_Wa=m*((V2/3.6)^2-(V1/3.6)^2)/2000 "Not using time interval"
W4_Wa=m*((V2/3.6)-(V1/3.6))/1000/Dt "Using velocities"
```

2-129 The elevator of a large building is to raise a net mass of 400 kg at a constant speed of 12 m/s using an electric motor. Minimum power rating of the motor should be

- (a) 0 kW (b) 4.8 kW (c) 47 kW (d) 12 kW (e) 36 kW

Answer (c) 47 kW

Solution Solved by EES Software. Solutions can be verified by copying-and-pasting the following lines on a blank EES screen. (Similar problems and their solutions can be obtained easily by modifying numerical values).

```
m=400 "kg"
V=12 "m/s"
g=9.81 "m/s^2"
Wg=m*g*V/1000 "kW"
"Some Wrong Solutions with Common Mistakes:"
W1_Wg=m*V "Not using g"
W2_Wg=m*g*V^2/2000 "Using kinetic energy"
W3_Wg=m*g/V "Using wrong relation"
```

2-130 Electric power is to be generated in a hydroelectric power plant that receives water at a rate of 70 m³/s from an elevation of 65 m using a turbine–generator with an efficiency of 85 percent. When frictional losses in piping are disregarded, the electric power output of this plant is

- (a) 3.9 MW (b) 38 MW (c) 45 MW (d) 53 MW (e) 65 MW

Answer (b) 38 MW

Solution Solved by EES Software. Solutions can be verified by copying-and-pasting the following lines on a blank EES screen. (Similar problems and their solutions can be obtained easily by modifying numerical values).

```
Vdot=70 "m3/s"
z=65 "m"
g=9.81 "m/s^2"
Eff=0.85
rho=1000 "kg/m3"
We=rho*Vdot*g*z*Eff/10^6 "MW"
"Some Wrong Solutions with Common Mistakes:"
W1_We=rho*Vdot*z*Eff/10^6 "Not using g"
W2_We=rho*Vdot*g*z/Eff/10^6 "Dividing by efficiency"
W3_We=rho*Vdot*g*z/10^6 "Not using efficiency"
```

2-131 Consider a refrigerator that consumes 320 W of electric power when it is running. If the refrigerator runs only one quarter of the time and the unit cost of electricity is \$0.09/kWh, the electricity cost of this refrigerator per month (30 days) is

- (a) \$3.56 (b) \$5.18 (c) \$8.54 (d) \$9.28 (e) \$20.74

Answer (b) \$5.18

Solution Solved by EES Software. Solutions can be verified by copying-and-pasting the following lines on a blank EES screen. (Similar problems and their solutions can be obtained easily by modifying numerical values).

```
We=0.320 "kW"
Hours=0.25*(24*30) "h/year"
price=0.09 "$/kWh"
Cost=We*hours*price
"Some Wrong Solutions with Common Mistakes:"
W1_cost= We*24*30*price "running continuously"
```

2-132 A 2-kW pump is used to pump kerosene ($\rho = 0.820$ kg/L) from a tank on the ground to a tank at a higher elevation. Both tanks are open to the atmosphere, and the elevation difference between the free surfaces of the tanks is 30 m. The maximum volume flow rate of kerosene is

- (a) 8.3 L/s (b) 7.2 L/s (c) 6.8 L/s (d) 12.1 L/s (e) 17.8 L/s

Answer (a) 8.3 L/s

Solution Solved by EES Software. Solutions can be verified by copying-and-pasting the following lines on a blank EES screen. (Similar problems and their solutions can be obtained easily by modifying numerical values).

```
W=2 "kW"
rho=0.820 "kg/L"
z=30 "m"
g=9.81 "m/s2"
W=rho*Vdot*g*z/1000
"Some Wrong Solutions with Common Mistakes:"
W=W1_Vdot*g*z/1000 "Not using density"
```

2-133 A glycerin pump is powered by a 5-kW electric motor. The pressure differential between the outlet and the inlet of the pump at full load is measured to be 211 kPa. If the flow rate through the pump is 18 L/s and the changes in elevation and the flow velocity across the pump are negligible, the overall efficiency of the pump is

- (a) 69% (b) 72% (c) 76% (d) 79% (e) 82%

Answer (c) 76%

Solution Solved by EES Software. Solutions can be verified by copying-and-pasting the following lines on a blank EES screen. (Similar problems and their solutions can be obtained easily by modifying numerical values).

```
We=5 "kW"
Vdot= 0.018 "m3/s"
DP=211 "kPa"
Emech=Vdot*DP
Emech=Eff*We
```

2-134 A 75 hp (shaft) compressor in a facility that operates at full load for 2500 hours a year is powered by an electric motor that has an efficiency of 93 percent. If the unit cost of electricity is \$0.06/kWh, the annual electricity cost of this compressor is

- (a) \$7802 (b) \$9021 (c) \$12,100 (d) \$8389 (e) \$10,460

Answer (b) \$9021

Solution Solved by EES Software. Solutions can be verified by copying-and-pasting the following lines on a blank EES screen. (Similar problems and their solutions can be obtained easily by modifying numerical values).

```
Wcomp=75 "hp"
Hours=2500 "h/year"
Eff=0.93
price=0.06 "$/kWh"
We=Wcomp*0.7457*Hours/Eff
Cost=We*price
"Some Wrong Solutions with Common Mistakes:"
W1_cost= Wcomp*0.7457*Hours*price*Eff "multiplying by efficiency"
W2_cost= Wcomp*Hours*price/Eff "not using conversion"
W3_cost= Wcomp*Hours*price*Eff "multiplying by efficiency and not using conversion"
W4_cost= Wcomp*0.7457*Hours*price "Not using efficiency"
```

The following problems are based on the optional special topic of heat transfer

2-135 A 10-cm high and 20-cm wide circuit board houses on its surface 100 closely spaced chips, each generating heat at a rate of 0.08 W and transferring it by convection to the surrounding air at 25°C. Heat transfer from the back surface of the board is negligible. If the convection heat transfer coefficient on the surface of the board is 10 W/m²·°C and radiation heat transfer is negligible, the average surface temperature of the chips is

- (a) 26°C (b) 45°C (c) 15°C (d) 80°C (e) 65°C

Answer (e) 65°C

Solution Solved by EES Software. Solutions can be verified by copying-and-pasting the following lines on a blank EES screen. (Similar problems and their solutions can be obtained easily by modifying numerical values).

$$A=0.10*0.20 \text{ "m}^2\text{"}$$

$$Q= 100*0.08 \text{ "W"}$$

$$T_{air}=25 \text{ "C"}$$

$$h=10 \text{ "W/m}^2\text{.C"}$$

$$Q= h*A*(T_s-T_{air}) \text{ "W"}$$

"Some Wrong Solutions with Common Mistakes:"

$$Q= h*(W1_T_s-T_{air}) \text{ "Not using area"}$$

$$Q= h*2*A*(W2_T_s-T_{air}) \text{ "Using both sides of surfaces"}$$

$$Q= h*A*(W3_T_s+T_{air}) \text{ "Adding temperatures instead of subtracting"}$$

$$Q/100= h*A*(W4_T_s-T_{air}) \text{ "Considering 1 chip only"}$$

2-136 A 50-cm-long, 0.2-cm-diameter electric resistance wire submerged in water is used to determine the boiling heat transfer coefficient in water at 1 atm experimentally. The surface temperature of the wire is measured to be 130°C when a wattmeter indicates the electric power consumption to be 4.1 kW. Then the heat transfer coefficient is

- (a) 43,500 W/m²·°C (b) 137 W/m²·°C (c) 68,330 W/m²·°C (d) 10,038 W/m²·°C
(e) 37,540 W/m²·°C

Answer (a) 43,500 W/m²·°C

Solution Solved by EES Software. Solutions can be verified by copying-and-pasting the following lines on a blank EES screen. (Similar problems and their solutions can be obtained easily by modifying numerical values).

$$L=0.5 \text{ "m"}$$

$$D=0.002 \text{ "m"}$$

$$A=\pi*D*L \text{ "m}^2\text{"}$$

$$W_e=4.1 \text{ "kW"}$$

$$T_s=130 \text{ "C"}$$

$$T_f=100 \text{ "C (Boiling temperature of water at 1 atm)"}$$

$$W_e= h*A*(T_s-T_f) \text{ "W"}$$

"Some Wrong Solutions with Common Mistakes:"

$$W_e= W1_h*(T_s-T_f) \text{ "Not using area"}$$

$$W_e= W2_h*(L*\pi*D^2/4)*(T_s-T_f) \text{ "Using volume instead of area"}$$

$$W_e= W3_h*A*T_s \text{ "Using } T_s \text{ instead of temp difference"}$$

2-137 A 3-m² hot black surface at 80°C is losing heat to the surrounding air at 25°C by convection with a convection heat transfer coefficient of 12 W/m²·°C, and by radiation to the surrounding surfaces at 15°C. The total rate of heat loss from the surface is

- (a) 1987 W (b) 2239 W (c) 2348 W (d) 3451 W (e) 3811 W

Answer (d) 3451 W

Solution Solved by EES Software. Solutions can be verified by copying-and-pasting the following lines on a blank EES screen. (Similar problems and their solutions can be obtained easily by modifying numerical values).

```
sigma=5.67E-8 "W/m^2.K^4"
eps=1
A=3 "m^2"
h_conv=12 "W/m^2.C"
Ts=80 "C"
Tf=25 "C"
Tsurr=15 "C"
Q_conv=h_conv*A*(Ts-Tf) "W"
Q_rad=eps*sigma*A*((Ts+273)^4-(Tsurr+273)^4) "W"
Q_total=Q_conv+Q_rad "W"
"Some Wrong Solutions with Common Mistakes:"
W1_Ql=Q_conv "Ignoring radiation"
W2_Q=Q_rad "ignoring convection"
W3_Q=Q_conv+eps*sigma*A*(Ts^4-Tsurr^4) "Using C in radiation calculations"
W4_Q=Q_total/A "not using area"
```

2-138 Heat is transferred steadily through a 0.2-m thick 8 m by 4 m wall at a rate of 2.4 kW. The inner and outer surface temperatures of the wall are measured to be 15°C to 5°C. The average thermal conductivity of the wall is

- (a) 0.002 W/m·°C (b) 0.75 W/m·°C (c) 1.0 W/m·°C (d) 1.5 W/m·°C (e) 3.0 W/m·°C

Answer (d) 1.5 W/m·°C

Solution Solved by EES Software. Solutions can be verified by copying-and-pasting the following lines on a blank EES screen. (Similar problems and their solutions can be obtained easily by modifying numerical values).

```
A=8*4 "m^2"
L=0.2 "m"
T1=15 "C"
T2=5 "C"
Q=2400 "W"
Q=k*A*(T1-T2)/L "W"
"Some Wrong Solutions with Common Mistakes:"
Q=W1_k*(T1-T2)/L "Not using area"
Q=W2_k*2*A*(T1-T2)/L "Using areas of both surfaces"
Q=W3_k*A*(T1+T2)/L "Adding temperatures instead of subtracting"
Q=W4_k*A*L*(T1-T2) "Multiplying by thickness instead of dividing by it"
```

2-139 The roof of an electrically heated house is 7 m long, 10 m wide, and 0.25 m thick. It is made of a flat layer of concrete whose thermal conductivity is 0.92 W/m.°C. During a certain winter night, the temperatures of the inner and outer surfaces of the roof are measured to be 15°C and 4°C, respectively. The average rate of heat loss through the roof that night was

- (a) 41 W (b) 177 W (c) 4894 W (d) 5567 W (e) 2834 W

Answer (e) 2834 W

Solution Solved by EES Software. Solutions can be verified by copying-and-pasting the following lines on a blank EES screen. (Similar problems and their solutions can be obtained easily by modifying numerical values).

$A=7*10$ "m^2"

$L=0.25$ "m"

$k=0.92$ "W/m.C"

$T1=15$ "C"

$T2=4$ "C"

$Q_cond=k*A*(T1-T2)/L$ "W"

"Some Wrong Solutions with Common Mistakes:"

$W1_Q=k*(T1-T2)/L$ "Not using area"

$W2_Q=k*2*A*(T1-T2)/L$ "Using areas of both surfaces"

$W3_Q=k*A*(T1+T2)/L$ "Adding temperatures instead of subtracting"

$W4_Q=k*A*L*(T1-T2)$ "Multiplying by thickness instead of dividing by it"

2-140 ... 2-147 Design and Essay Problems



Solutions Manual for
Thermodynamics: An Engineering Approach
8th Edition
Yunus A. Cengel, Michael A. Boles
McGraw-Hill, 2015

Chapter 3

PROPERTIES OF PURE SUBSTANCES

PROPRIETARY AND CONFIDENTIAL

This Manual is the proprietary property of McGraw-Hill Education and protected by copyright and other state and federal laws. By opening and using this Manual the user agrees to the following restrictions, and if the recipient does not agree to these restrictions, the Manual should be promptly returned unopened to McGraw-Hill Education: **This Manual is being provided only to authorized professors and instructors for use in preparing for the classes using the affiliated textbook. No other use or distribution of this Manual is permitted. This Manual may not be sold and may not be distributed to or used by any student or other third party. No part of this Manual may be reproduced, displayed or distributed in any form or by any means, electronic or otherwise, without the prior written permission of McGraw-Hill Education.**

Pure Substances, Phase Change Processes, Property Diagrams

3-1C Yes. Because it has the same chemical composition throughout.

3-2C A vapor that is about to condense is saturated vapor; otherwise it is superheated vapor.

3-3C No.

3-4C Because one cannot be varied while holding the other constant. In other words, when one changes, so does the other one.

3-5C Yes. The saturation temperature of a pure substance depends on pressure. The higher the pressure, the higher the saturation or boiling temperature.

3-6C At critical point the saturated liquid and the saturated vapor states are identical. At triple point the three phases of a pure substance coexist in equilibrium.

3-7C Yes.

3-8C Case (c) when the pan is covered with a heavy lid. Because the heavier the lid, the greater the pressure in the pan, and thus the greater the cooking temperature.

Property Tables

3-9C A given volume of water will boil at a higher temperature in a **tall and narrow pot** since the pressure at the bottom (and thus the corresponding saturation pressure) will be higher in that case.

3-10C The molar mass of gasoline (C_8H_{18}) is 114 kg/kmol, which is much larger than the molar mass of air that is 29 kg/kmol. Therefore, the gasoline vapor will settle down instead of rising even if it is at a much higher temperature than the surrounding air. As a result, the warm mixture of air and gasoline on top of an open gasoline will most likely settle down instead of rising in a cooler environment

3-11C Yes. Otherwise we can create energy by alternately vaporizing and condensing a substance.

3-12C No. Because in the thermodynamic analysis we deal with the changes in properties; and the changes are independent of the selected reference state.

3-13C The term h_{fg} represents the amount of energy needed to vaporize a unit mass of saturated liquid at a specified temperature or pressure. It can be determined from $h_{fg} = h_g - h_f$.

3-14C Yes. It decreases with increasing pressure and becomes zero at the critical pressure.

3-15C Yes; the higher the temperature the lower the h_{fg} value.

3-16C Quality is the fraction of vapor in a saturated liquid-vapor mixture. It has no meaning in the superheated vapor region.

3-17C Completely vaporizing 1 kg of saturated liquid at 1 atm pressure since the higher the pressure, the lower the h_{fg} .

3-18C The compressed liquid can be approximated as a saturated liquid at the given temperature. Thus $v_{T,P} \cong v_{f@T}$.

3-19C Ice can be made by evacuating the air in a water tank. During evacuation, vapor is also thrown out, and thus the vapor pressure in the tank drops, causing a difference between the vapor pressures at the water surface and in the tank. This pressure difference is the driving force of vaporization, and forces the liquid to evaporate. But the liquid must absorb the heat of vaporization before it can vaporize, and it absorbs it from the liquid and the air in the neighborhood, causing the temperature in the tank to drop. The process continues until water starts freezing. The process can be made more efficient by insulating the tank well so that the entire heat of vaporization comes essentially from the water.

3-20 Complete the following table for H_2O :

$T, ^\circ\text{C}$	P, kPa	$u, \text{kJ/kg}$	Phase description
143.61	400	1450	<i>Saturated mixture</i>
220	2319.6	2601.3	Saturated vapor
190	2500	805.15	<i>Compressed liquid</i>
466.21	4000	3040	<i>Superheated vapor</i>

3-21  Complete the following table for H_2O :

$T, ^\circ\text{C}$	P, kPa	$v, \text{m}^3/\text{kg}$	Phase description
50	12.35	7.72	<i>Saturated mixture</i>
143.6	400	0.4624	Saturated vapor
250	500	0.4744	<i>Superheated vapor</i>
110	350	0.001051	<i>Compressed liquid</i>



3-22 Problem 3-21 is reconsidered. The missing properties of water are to be determined using EES, and the solution is to be repeated for refrigerant-134a, refrigerant-22, and ammonia.

Analysis The problem is solved using EES, and the solution is given below.

"Given"

T[1]=50 [C]
 v[1]=7.72 [m³/kg]
 P[2]=400 [kPa]
 x[2]=1
 T[3]=250 [C]
 P[3]=500 [kPa]
 T[4]=110 [C]
 P[4]=350 [kPa]

"Analysis"

Fluid\$='steam_iapws' "Change the Fluid to R134a, R22 and Ammonia and solve"
 P[1]=pressure(Fluid\$, T=T[1], v=v[1])
 x[1]=quality(Fluid\$, T=T[1], v=v[1])
 T[2]=temperature(Fluid\$, P=P[2], x=x[2])
 v[2]=volume(Fluid\$, P=P[2], x=x[2])
 v[3]=volume(Fluid\$, P=P[3], T=T[3])
 x[3]=quality(Fluid\$, P=P[3], T=T[3])
 v[4]=volume(Fluid\$, P=P[4], T=T[4])
 x[4]=quality(Fluid\$, P=P[4], T=T[4])
 "x = 100 for superheated vapor and x = -100 for compressed liquid"

SOLUTION for water

T [C]	P [kPa]	x	v [kg/m ³]
50.00	12.35	0.6419	7.72
143.61	400.00	1	0.4624
250.00	500.00	100	0.4744
110.00	350.00	-100	0.001051

SOLUTION for R-134a

T [C]	P [kPa]	x	v [kg/m ³]
50.00	3.41	100	7.72
8.91	400.00	1	0.05127
250.00	500.00	-	-
110.00	350.00	100	0.08666

SOLUTION for R-22

T [C]	P [kPa]	X	v [kg/m ³]
50.00	4.02	100	7.72
-6.56	400.00	1	0.05817
250.00	500.00	100	0.09959
110.00	350.00	100	0.103

SOLUTION for Ammonia

T [C]	P [kPa]	X	v [kg/m ³]
50.00	20.40	100	7.72
-1.89	400.00	1	0.3094
250.00	500.00	100	0.5076
110.00	350.00	100	0.5269

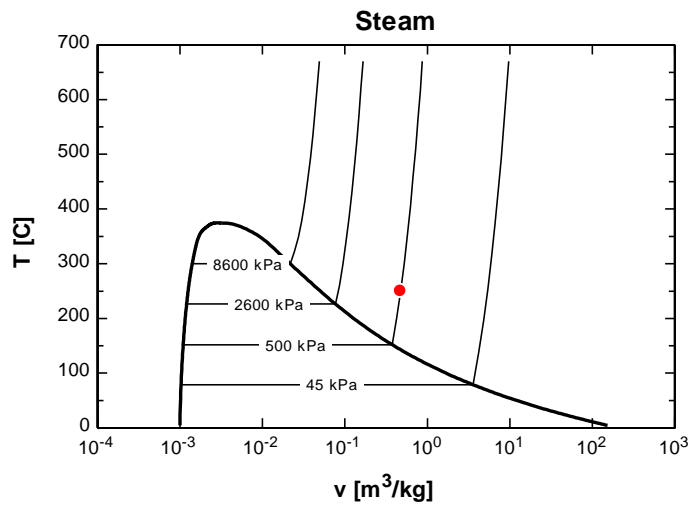
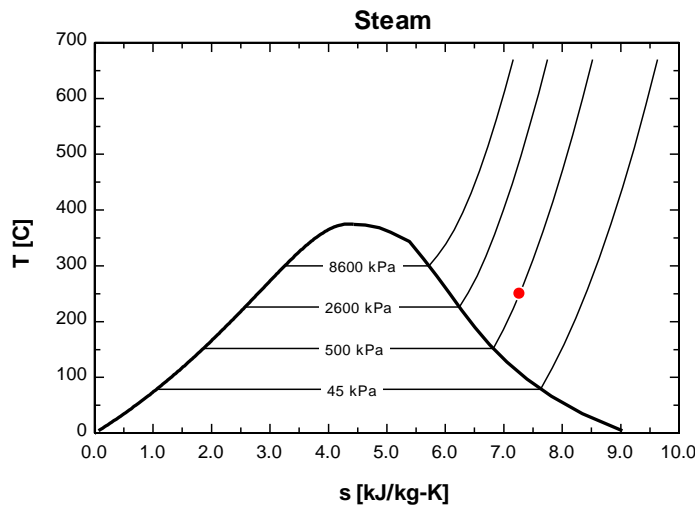

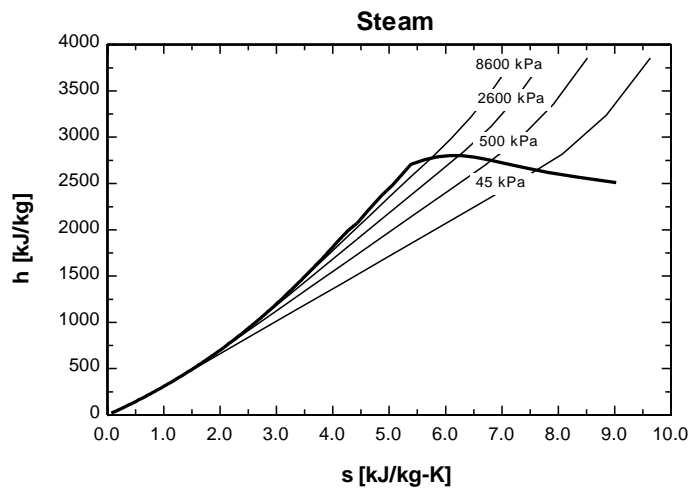
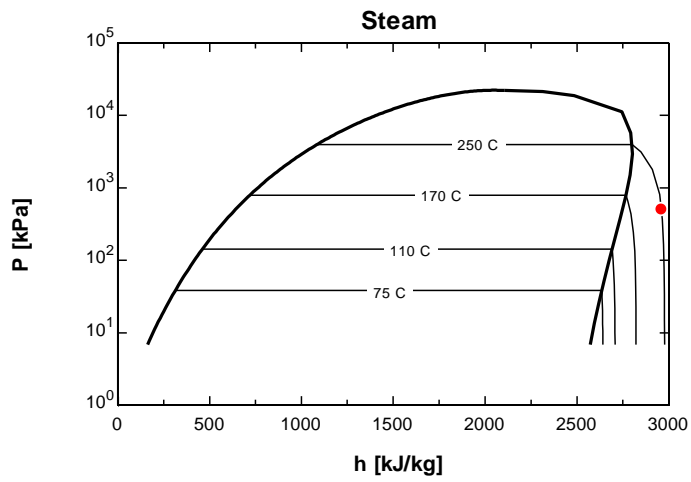
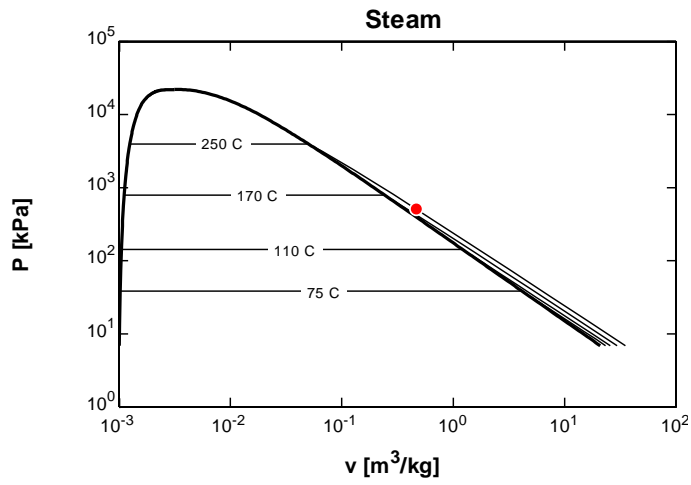

3-23 Complete the following table for H_2O :

T, °C	P, kPa	ν , m ³ / kg	Phase description
140	361.53	0.05	<i>Saturated mixture</i>
155.46	550	0.001097	Saturated liquid
125	750	0.001065	<i>Compressed liquid</i>
500	2500	0.140	<i>Superheated vapor</i>

3-24E Complete the following table for H_2O :

T, °F	P, psia	u , Btu / lbm	Phase description
300	67.03	782	<i>Saturated mixture</i>
267.22	40	236.02	Saturated liquid
500	120	1174.4	<i>Superheated vapor</i>
400	400	373.84	<i>Compressed liquid</i>



3-25E Problem 3-24E is reconsidered. The missing properties of water are to be determined using EES, and the solution is to be repeated for refrigerant-134a, refrigerant-22, and ammonia.

Analysis The problem is solved using EES, and the solution is given below.

"Given"

T[1]=300 [F]
 u[1]=782 [Btu/lbm]
 P[2]=40 [psia]
 x[2]=0
 T[3]=500 [F]
 P[3]=120 [psia]
 T[4]=400 [F]
 P[4]=420 [psia]

"Analysis"

```
Fluid$='steam_iapws'
P[1]=pressure(Fluid$, T=T[1], u=u[1])
x[1]=quality(Fluid$, T=T[1], u=u[1])
T[2]=temperature(Fluid$, P=P[2], x=x[2])
u[2]=intenergy(Fluid$, P=P[2], x=x[2])
u[3]=intenergy(Fluid$, P=P[3], T=T[3])
x[3]=quality(Fluid$, P=P[3], T=T[3])
u[4]=intenergy(Fluid$, P=P[4], T=T[4])
x[4]=quality(Fluid$, P=P[4], T=T[4])
"x = 100 for superheated vapor and x = -100 for compressed liquid"
```

Solution for steam

T, °F	P, psia	x	u, Btu/lbm
300	67.028	0.6173	782
267.2	40	0	236
500	120	100	1174
400	400	-100	373.8

Solution for R134a

T, °F	P, psia	x	u, Btu/lbm
300	-	-	782
29.01	40	0	21.24
500	120	100	203.5
400	400	100	173.6

Solution for R22

T, °F	P, psia	x	u, Btu/lbm
300	-	-	782
1.534	40	0	78.08
500	120	100	240.1
400	400	100	218.7

Solution for ammonia

T, °F	P, psia	x	u, Btu/lbm
300	-	-	782
11.67	40	0	63.47
500	120	100	785.5
400	400	100	727

3-26 Complete the following table for Refrigerant-134a:

T, °C	P, kPa	ν , m ³ /kg	Phase description
-4	320	0.000764	Compressed liquid
10	414.89	0.0065	Saturated mixture
33.45	850	0.02409	Saturated vapor
60	600	0.04632	Superheated vapor

3-27E Complete the following table for Refrigerant-134a:

T, °F	P, psia	h, Btu/lbm	x	Phase description
65.89	80	78	0.566	Saturated mixture
15	29.759	69.92	0.6	Saturated mixture
10	70	15.36	- - -	Compressed liquid
160	180	129.46	- - -	Superheated vapor
110	161.16	117.25	1.0	Saturated vapor

3-28 A rigid tank contains steam at a specified state. The pressure, quality, and density of steam are to be determined.

Properties At 220°C $\nu_f = 0.001190$ m³/kg and $\nu_g = 0.08609$ m³/kg (Table A-4).

Analysis (a) Two phases coexist in equilibrium, thus we have a saturated liquid-vapor mixture. The pressure of the steam is the saturation pressure at the given temperature. Then the pressure in the tank must be the saturation pressure at the specified temperature,

$$P = T_{\text{sat}@220^\circ\text{C}} = \mathbf{2320\text{kPa}}$$

(b) The total mass and the quality are determined as

$$m_f = \frac{\nu_f}{\nu_f} = \frac{1/3 \times (1.8 \text{ m}^3)}{0.001190 \text{ m}^3/\text{kg}} = 504.2 \text{ kg}$$

$$m_g = \frac{\nu_g}{\nu_g} = \frac{2/3 \times (1.8 \text{ m}^3)}{0.08609 \text{ m}^3/\text{kg}} = 13.94 \text{ kg}$$

$$m_t = m_f + m_g = 504.2 + 13.94 = 518.1 \text{ kg}$$

$$x = \frac{m_g}{m_t} = \frac{13.94}{518.1} = \mathbf{0.0269}$$

(c) The density is determined from

$$\nu = \nu_f + x(\nu_g - \nu_f) = 0.001190 + (0.0269)(0.08609) = 0.003474 \text{ m}^3/\text{kg}$$

$$\rho = \frac{1}{\nu} = \frac{1}{0.003474} = \mathbf{287.8\text{kg/m}^3}$$

Steam 1.8 m ³ 220°C

3-29 A piston-cylinder device contains R-134a at a specified state. Heat is transferred to R-134a. The final pressure, the volume change of the cylinder, and the enthalpy change are to be determined.

Analysis (a) The final pressure is equal to the initial pressure, which is determined from

$$P_2 = P_1 = P_{\text{atm}} + \frac{m_p g}{\pi D^2 / 4} = 88 \text{ kPa} + \frac{(12 \text{ kg})(9.81 \text{ m/s}^2)}{\pi(0.25 \text{ m})^2 / 4} \left(\frac{1 \text{ kN}}{1000 \text{ kg}\cdot\text{m/s}^2} \right) = \mathbf{90.4 \text{ kPa}}$$

(b) The specific volume and enthalpy of R-134a at the initial state of 90.4 kPa and -10°C and at the final state of 90.4 kPa and 15°C are (from EES)

$$\nu_1 = 0.2302 \text{ m}^3/\text{kg} \quad h_1 = 247.77 \text{ kJ/kg}$$

$$\nu_2 = 0.2544 \text{ m}^3/\text{kg} \quad h_2 = 268.18 \text{ kJ/kg}$$

The initial and the final volumes and the volume change are

$$V_1 = m\nu_1 = (0.85 \text{ kg})(0.2302 \text{ m}^3/\text{kg}) = 0.1957 \text{ m}^3$$

$$V_2 = m\nu_2 = (0.85 \text{ kg})(0.2544 \text{ m}^3/\text{kg}) = 0.2162 \text{ m}^3$$

$$\Delta V = 0.2162 - 0.1957 = \mathbf{0.0205 \text{ m}^3}$$

(c) The total enthalpy change is determined from

$$\Delta H = m(h_2 - h_1) = (0.85 \text{ kg})(268.18 - 247.77) \text{ kJ/kg} = \mathbf{17.4 \text{ kJ/kg}}$$

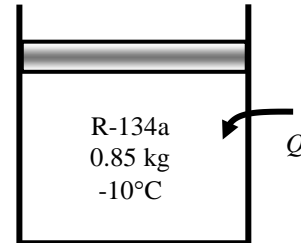

3-30E The temperature of R-134a at a specified state is to be determined.

Analysis Since the specified specific volume is higher than ν_g for 80 psia, this is a superheated vapor state. From R-134a tables,

$$\left. \begin{array}{l} P = 80 \text{ psia} \\ \nu = 0.6243 \text{ ft}^3/\text{lbm} \end{array} \right\} T = \mathbf{80^\circ\text{F}} \quad (\text{Table A - 13E})$$

3-31 A rigid container that is filled with R-134a is heated. The final temperature and initial pressure are to be determined.

Analysis This is a constant volume process. The specific volume is

$$\nu_1 = \nu_2 = \frac{V}{m} = \frac{1.348 \text{ m}^3}{10 \text{ kg}} = 0.1348 \text{ m}^3/\text{kg}$$

The initial state is determined to be a mixture, and thus the pressure is the saturation pressure at the given temperature

$$P_1 = P_{\text{sat @ } -40^\circ\text{C}} = \mathbf{51.25 \text{ kPa}} \quad (\text{Table A - 11})$$

The final state is superheated vapor and the temperature is determined by interpolation to be

$$\left. \begin{array}{l} P_2 = 200 \text{ kPa} \\ \nu_2 = 0.1348 \text{ m}^3/\text{kg} \end{array} \right\} T_2 = \mathbf{66.3^\circ\text{C}} \quad (\text{Table A - 13})$$

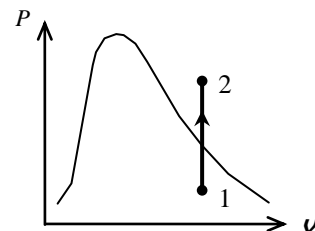
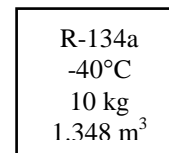

3-32 The enthalpy of R-134a at a specified state is to be determined.

Analysis The specific volume is

$$v = \frac{V}{m} = \frac{9 \text{ m}^3}{300 \text{ kg}} = 0.03 \text{ m}^3/\text{kg}$$

Inspection of Table A-11 indicates that this is a mixture of liquid and vapor. Using the properties at 10°C line, the quality and the enthalpy are determined to be

$$x = \frac{v - v_f}{v_{fg}} = \frac{(0.03 - 0.0007929) \text{ m}^3/\text{kg}}{(0.049466 - 0.0007929) \text{ m}^3/\text{kg}} = 0.6001$$

$$h = h_f + xh_{fg} = 65.42 + (0.6001)(190.80) = \mathbf{179.9 \text{ kJ/kg}}$$

3-33 The specific volume of R-134a at a specified state is to be determined.

Analysis Since the given temperature is higher than the saturation temperature for 200 kPa, this is a superheated vapor state. The specific volume is then

$$\left. \begin{array}{l} P = 200 \text{ kPa} \\ T = 25^\circ\text{C} \end{array} \right\} v = \mathbf{0.11647 \text{ m}^3/\text{kg}} \text{ (Table A - 13)}$$

3-34 The average atmospheric pressure in Denver is 83.4 kPa. The boiling temperature of water in Denver is to be determined.

Analysis The boiling temperature of water in Denver is the saturation temperature corresponding to the atmospheric pressure in Denver, which is 83.4 kPa:

$$T = T_{\text{sat}@83.4 \text{ kPa}} = \mathbf{94.6^\circ\text{C}} \quad \text{(Table A-5)}$$

3-35E The temperature in a pressure cooker during cooking at sea level is measured to be 250°F. The absolute pressure inside the cooker and the effect of elevation on the answer are to be determined.

Assumptions Properties of pure water can be used to approximate the properties of juicy water in the cooker.

Properties The saturation pressure of water at 250°F is 29.84 psia (Table A-4E). The standard atmospheric pressure at sea level is 1 atm = 14.7 psia.

Analysis The absolute pressure in the cooker is simply the saturation pressure at the cooking temperature,

$$P_{\text{abs}} = P_{\text{sat}@250^\circ\text{F}} = \mathbf{29.84 \text{ psia}}$$

It is equivalent to

$$P_{\text{abs}} = 29.84 \text{ psia} \left(\frac{1 \text{ atm}}{14.7 \text{ psia}} \right) = \mathbf{2.03 \text{ atm}}$$

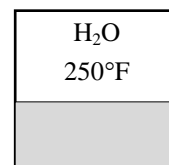

The elevation has **no effect** on the absolute pressure inside when the temperature is maintained constant at 250°F.

3-36E A spring-loaded piston-cylinder device is filled with R-134a. The water now undergoes a process until its volume increases by 50%. The final temperature and the enthalpy are to be determined.

Analysis From Table A-11E, the initial specific volume is

$$v_1 = v_f + x_1 v_{fg} = 0.01143 + (0.80)(4.4286 - 0.01143) = 3.5452 \text{ ft}^3/\text{lbm}$$

and the initial volume will be

$$V_1 = m v_1 = (0.13 \text{ lbm})(3.5452 \text{ ft}^3/\text{lbm}) = 0.4609 \text{ ft}^3$$

With a 50% increase in the volume, the final volume will be

$$V_2 = 1.4 V_1 = 1.5(0.4609 \text{ ft}^3) = 0.6913 \text{ ft}^3$$

The distance that the piston moves between the initial and final conditions is

$$\Delta x = \frac{\Delta V}{A_p} = \frac{V_2 - V_1}{\pi D^2 / 4} = \frac{(0.6913 - 0.4609) \text{ ft}^3}{\pi (1 \text{ ft})^2 / 4} = 0.2934 \text{ ft}$$

As a result of the compression of the spring, the pressure difference between the initial and final states is

$$\Delta P = \frac{\Delta F}{A_p} = \frac{k \Delta x}{A_p} = \frac{k \Delta x}{\pi D^2 / 4} = \frac{4(37 \text{ lbf/in})(0.2934 \times 12 \text{ in})}{\pi (12 \text{ in})^2} = 1.152 \text{ lbf/in}^2 = 1.152 \text{ psia}$$

The initial pressure is

$$P_1 = P_{\text{sat @ } -30^\circ\text{F}} = 9.869 \text{ psia} \quad (\text{Table A - 11E})$$

The final pressure is then

$$P_2 = P_1 + \Delta P = 9.869 + 1.152 = 11.02 \text{ psia}$$

and the final specific volume is

$$v_2 = \frac{V_2}{m} = \frac{0.6913 \text{ ft}^3}{0.13 \text{ lbm}} = 5.318 \text{ ft}^3/\text{lbm}$$

At this final state, the temperature and enthalpy are

$$\left. \begin{array}{l} P_2 = 11.02 \text{ psia} \\ v_2 = 5.318 \text{ ft}^3/\text{lbm} \end{array} \right\} \begin{array}{l} T_2 = \mathbf{104.7^\circ\text{F}} \\ h_2 = \mathbf{124.7 \text{ Btu/lbm}} \end{array} \quad (\text{from EES})$$

Note that it is very difficult to get the temperature and enthalpy readings from Table A-13E accurately.

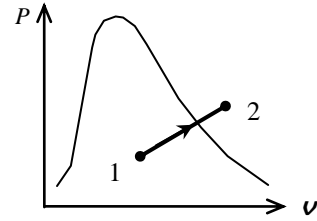

3-37E A piston-cylinder device that is filled with water is cooled. The final pressure and volume of the water are to be determined.

Analysis The initial specific volume is

$$v_1 = \frac{V_1}{m} = \frac{2.4264 \text{ ft}^3}{1 \text{ lbm}} = 2.4264 \text{ ft}^3/\text{lbm}$$

This is a constant-pressure process. The initial state is determined to be superheated vapor and thus the pressure is determined to be

$$\left. \begin{array}{l} T_1 = 600^\circ\text{F} \\ v_1 = 2.4264 \text{ ft}^3/\text{lbm} \end{array} \right\} P_1 = P_2 = \mathbf{250 \text{ psia}} \quad (\text{Table A - 6E})$$

The saturation temperature at 250 psia is 400.1°F. Since the final temperature is less than this temperature, the final state is compressed liquid. Using the incompressible liquid approximation,

$$v_2 = v_f @ 200^\circ\text{F} = 0.01663 \text{ ft}^3/\text{lbm} \quad (\text{Table A - 4E})$$

The final volume is then

$$V_2 = m v_2 = (1 \text{ lbm})(0.01663 \text{ ft}^3/\text{lbm}) = \mathbf{0.01663 \text{ ft}^3}$$

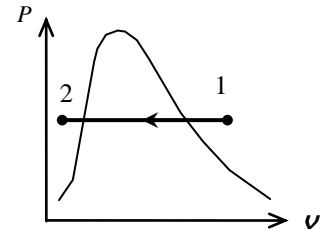
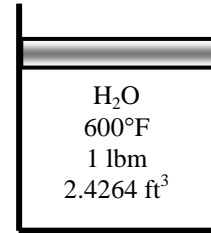

3-38 The volume of a container that contains water at a specified state is to be determined.

Analysis The specific volume is determined from steam tables by interpolation to be

$$\left. \begin{array}{l} P = 100 \text{ kPa} \\ T = 150^\circ\text{C} \end{array} \right\} v = 1.9367 \text{ m}^3/\text{kg} \quad (\text{Table A - 6})$$

The volume of the container is then

$$V = m v = (3 \text{ kg})(1.9367 \text{ m}^3/\text{kg}) = \mathbf{5.81 \text{ m}^3}$$

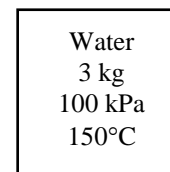

3-39 Water is boiled at sea level (1 atm pressure) in a pan placed on top of a 3-kW electric burner that transfers 60% of the heat generated to the water. The rate of evaporation of water is to be determined.

Properties The properties of water at 1 atm and thus at the saturation temperature of 100°C are $h_{fg} = 2256.4 \text{ kJ/kg}$ (Table A-4).

Analysis The net rate of heat transfer to the water is

$$\dot{Q} = 0.60 \times 3 \text{ kW} = 1.8 \text{ kW}$$

Noting that it takes 2256.4 kJ of energy to vaporize 1 kg of saturated liquid water, the rate of evaporation of water is determined to be

$$\dot{m}_{\text{evaporation}} = \frac{\dot{Q}}{h_{fg}} = \frac{1.8 \text{ kJ/s}}{2256.4 \text{ kJ/kg}} = 0.80 \times 10^{-3} \text{ kg/s} = \mathbf{2.872 \text{ kg/h}}$$

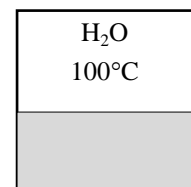

3-40 Water is boiled at 1500 m (84.5 kPa pressure) in a pan placed on top of a 3-kW electric burner that transfers 60% of the heat generated to the water. The rate of evaporation of water is to be determined.

Properties The properties of water at 84.5 kPa and thus at the saturation temperature of 95°C are $h_{fg} = 2269.6$ kJ/kg (Table A-4).

Analysis The net rate of heat transfer to the water is

$$\dot{Q} = 0.60 \times 3 \text{ kW} = 1.8 \text{ kW}$$

Noting that it takes 2269.6 kJ of energy to vaporize 1 kg of saturated liquid water, the rate of evaporation of water is determined to be

$$\dot{m}_{\text{evaporation}} = \frac{\dot{Q}}{h_{fg}} = \frac{1.8 \text{ kJ/s}}{2269.6 \text{ kJ/kg}} = 0.793 \times 10^{-3} \text{ kg/s} = 2.855 \text{ kg/h}$$

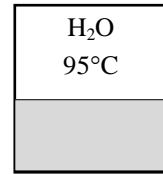

3-41 A rigid container that is filled with R-134a is heated. The temperature and total enthalpy are to be determined at the initial and final states.

Analysis This is a constant volume process. The specific volume is

$$\nu_1 = \nu_2 = \frac{\nu}{m} = \frac{0.014 \text{ m}^3}{10 \text{ kg}} = 0.0014 \text{ m}^3/\text{kg}$$

The initial state is determined to be a mixture, and thus the temperature is the saturation temperature at the given pressure. From Table A-12 by interpolation

$$T_1 = T_{\text{sat @ 300kPa}} = 0.61^\circ\text{C}$$

Using EES, we would get 0.65°C. Then,

$$x_1 = \frac{\nu_1 - \nu_f}{\nu_{fg}} = \frac{(0.0014 - 0.0007735) \text{ m}^3/\text{kg}}{(0.067776 - 0.0007735) \text{ m}^3/\text{kg}} = 0.009351$$

$$h_1 = h_f + x_1 h_{fg} = 52.71 + (0.009351)(198.17) = 54.56 \text{ kJ/kg}$$

The total enthalpy is then

$$H_1 = m h_1 = (10 \text{ kg})(54.56 \text{ kJ/kg}) = 545.6 \text{ kJ}$$

The final state is also saturated mixture. Repeating the calculations at this state,

$$T_2 = T_{\text{sat @ 600kPa}} = 21.55^\circ\text{C}$$

$$x_2 = \frac{\nu_2 - \nu_f}{\nu_{fg}} = \frac{(0.0014 - 0.0008198) \text{ m}^3/\text{kg}}{(0.034335 - 0.0008198) \text{ m}^3/\text{kg}} = 0.01731$$

$$h_2 = h_f + x_2 h_{fg} = 81.50 + (0.01731)(180.95) = 84.64 \text{ kJ/kg}$$

$$H_2 = m h_2 = (10 \text{ kg})(84.64 \text{ kJ/kg}) = 846.4 \text{ kJ}$$

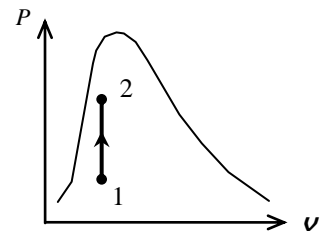
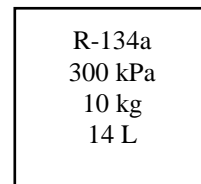

3-42 A piston-cylinder device that is filled with R-134a is cooled at constant pressure. The final temperature and the change of total internal energy are to be determined.

Analysis The initial specific volume is

$$v_1 = \frac{V}{m} = \frac{12.322 \text{ m}^3}{100 \text{ kg}} = 0.12322 \text{ m}^3/\text{kg}$$

The initial state is superheated and the internal energy at this state is

$$\left. \begin{array}{l} P_1 = 200 \text{ kPa} \\ v_1 = 0.12322 \text{ m}^3/\text{kg} \end{array} \right\} u_1 = 263.08 \text{ kJ/kg (Table A - 13)}$$

The final specific volume is

$$v_2 = \frac{v_1}{2} = \frac{0.12322 \text{ m}^3/\text{kg}}{2} = 0.06161 \text{ m}^3/\text{kg}$$

This is a constant pressure process. The final state is determined to be saturated mixture whose temperature is

$$T_2 = T_{\text{sat @ 200kPa}} = -10.09^\circ\text{C (Table A - 12)}$$

The internal energy at the final state is (Table A-12)

$$x_2 = \frac{v_2 - v_f}{v_{fg}} = \frac{(0.06161 - 0.0007532) \text{ m}^3/\text{kg}}{(0.099951 - 0.0007532) \text{ m}^3/\text{kg}} = 0.6135$$

$$u_2 = u_f + x_2 u_{fg} = 38.26 + (0.6135)(186.25) = 152.52 \text{ kJ/kg}$$

Hence, the change in the internal energy is

$$\Delta u = u_2 - u_1 = 152.52 - 263.08 = -110.6 \text{ kJ/kg}$$

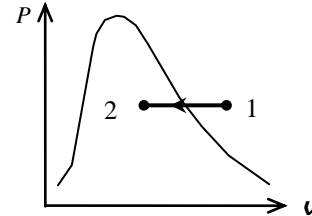
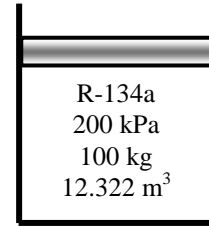

3-43 A piston-cylinder device fitted with stops contains water at a specified state. Now the water is cooled until a final pressure. The process is to be indicated on the T - ν diagram and the change in internal energy is to be determined.

Analysis The process is shown on T - ν diagram. The internal energy at the initial state is

$$\left. \begin{array}{l} P_1 = 200 \text{ kPa} \\ T_1 = 300^\circ\text{C} \end{array} \right\} u_1 = 2808.8 \text{ kJ/kg (Table A - 6)}$$

State 2 is saturated vapor at the initial pressure. Then,

$$\left. \begin{array}{l} P_2 = 200 \text{ kPa} \\ x_2 = 1 \text{ (sat. vapor)} \end{array} \right\} \nu_2 = 0.8858 \text{ m}^3/\text{kg (Table A - 5)}$$

Process 2-3 is a constant-volume process. Thus,

$$\left. \begin{array}{l} P_3 = 100 \text{ kPa} \\ \nu_3 = \nu_2 = 0.8858 \text{ m}^3/\text{kg} \end{array} \right\} u_3 = 1508.6 \text{ kJ/kg (Table A - 5)}$$

The overall change in internal energy is

$$\Delta u = u_1 - u_3 = 2808.8 - 1508.6 = \mathbf{1300 \text{ kJ/kg}}$$

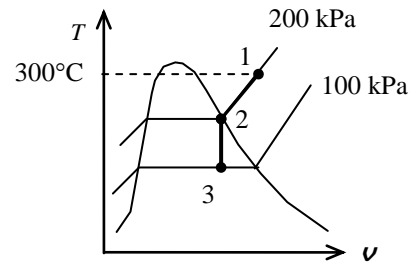
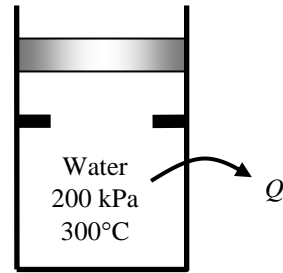

3-44 Saturated steam at $T_{\text{sat}} = 40^\circ\text{C}$ condenses on the outer surface of a cooling tube at a rate of 130 kg/h. The rate of heat transfer from the steam to the cooling water is to be determined.

Assumptions 1 Steady operating conditions exist. 2 The condensate leaves the condenser as a saturated liquid at 30°C .

Properties The properties of water at the saturation temperature of 40°C are $h_{fg} = 2406.0 \text{ kJ/kg}$ (Table A-4).

Analysis Noting that 2406.0 kJ of heat is released as 1 kg of saturated vapor at 40°C condenses, the rate of heat transfer from the steam to the cooling water in the tube is determined directly from

$$\begin{aligned} \dot{Q} &= \dot{m}_{\text{evap}} h_{fg} \\ &= (130 \text{ kg/h})(2406.0 \text{ kJ/kg}) = 312,780 \text{ kJ/h} \\ &= \mathbf{86.9 \text{ kW}} \end{aligned}$$

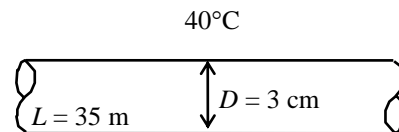

3-45 The boiling temperature of water in a 5-cm deep pan is given. The boiling temperature in a 40-cm deep pan is to be determined.

Assumptions Both pans are full of water.

Properties The density of liquid water is approximately $\rho = 1000 \text{ kg/m}^3$.

Analysis The pressure at the bottom of the 5-cm pan is the saturation pressure corresponding to the boiling temperature of 98°C :

$$P = P_{\text{sat}@98^\circ\text{C}} = 94.39 \text{ kPa} \quad (\text{Table A-4})$$

The pressure difference between the bottoms of two pans is

$$\Delta P = \rho gh = (1000 \text{ kg/m}^3)(9.807 \text{ m/s}^2)(0.35 \text{ m}) \left(\frac{1 \text{ kPa}}{1000 \text{ kg/m} \cdot \text{s}^2} \right) = 3.43 \text{ kPa}$$

Then the pressure at the bottom of the 40-cm deep pan is

$$P = 94.39 + 3.43 = 97.82 \text{ kPa}$$

Then the boiling temperature becomes

$$T_{\text{boiling}} = T_{\text{sat}@97.82 \text{ kPa}} = \mathbf{99.0^\circ\text{C}} \quad (\text{Table A-5})$$

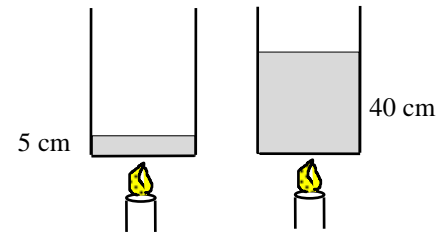

3-46 A cooking pan is filled with water and covered with a 4-kg lid. The boiling temperature of water is to be determined.

Analysis The pressure in the pan is determined from a force balance on the lid,

$$PA = P_{\text{atm}}A + W$$

or,

$$\begin{aligned} P &= P_{\text{atm}} + \frac{mg}{A} \\ &= (101 \text{ kPa}) + \frac{(4 \text{ kg})(9.81 \text{ m/s}^2)}{\pi(0.1 \text{ m})^2} \left(\frac{1 \text{ kPa}}{1000 \text{ kg/m} \cdot \text{s}^2} \right) \\ &= 102.25 \text{ kPa} \end{aligned}$$

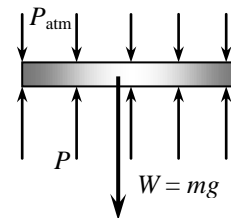

The boiling temperature is the saturation temperature corresponding to this pressure,

$$T = T_{\text{sat}@102.25 \text{ kPa}} = \mathbf{100.2^\circ\text{C}} \quad (\text{Table A-5})$$



3-47 Prob. 3-46 is reconsidered. Using EES (or other) software, the effect of the mass of the lid on the boiling temperature of water in the pan is to be investigated. The mass is to vary from 1 kg to 10 kg, and the boiling temperature is to be plotted against the mass of the lid.

Analysis The problem is solved using EES, and the solution is given below.

"Given data"
 {P_atm=101[kPa]}
 D_lid=20 [cm]
 {m_lid=4 [kg]}

"Solution"
 "The atmospheric pressure in kPa varies with altitude in km by the approximate function:"
 $P_{atm}=101.325*(1-0.02256*z)^{5.256}$
 "The local acceleration of gravity at 45 degrees latitude as a function of altitude in m is given by:"
 $g=9.807+3.32*10^{-6}*z*convert(km,m)$

"At sea level:"
 z=0 "[km]"
 $A_{lid}=\pi*D_{lid}^2/4*convert(cm^2,m^2)$
 $W_{lid}=m_{lid}*g*convert(kg*m/s^2,N)$
 $P_{lid}=W_{lid}/A_{lid}*convert(N/m^2,kPa)$
 $P_{water}=P_{lid}+P_{atm}$
 $T_{water}=temperature(steam_iapws,P=P_{water},x=0)$

m _{lid} [kg]	T _{water} [C]
1	100.1
2	100.1
3	100.2
4	100.3
5	100.4
6	100.5
7	100.6
8	100.7
9	100.7
10	100.8

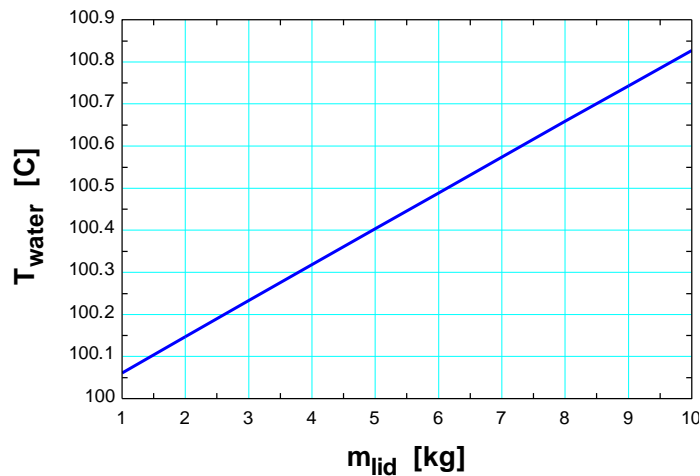

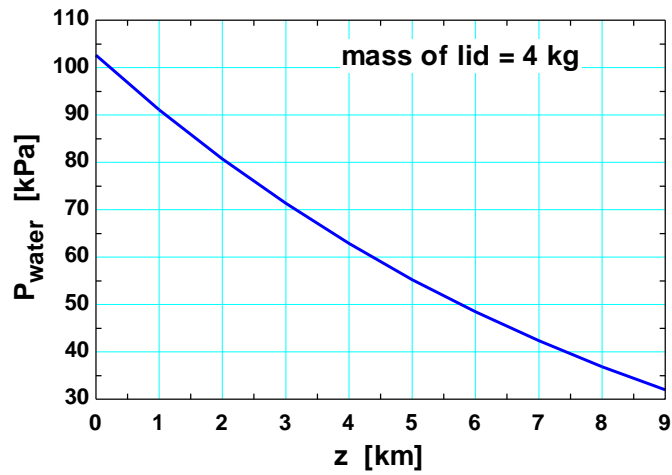

Effect of altitude on boiling pressure of water in pan with lid

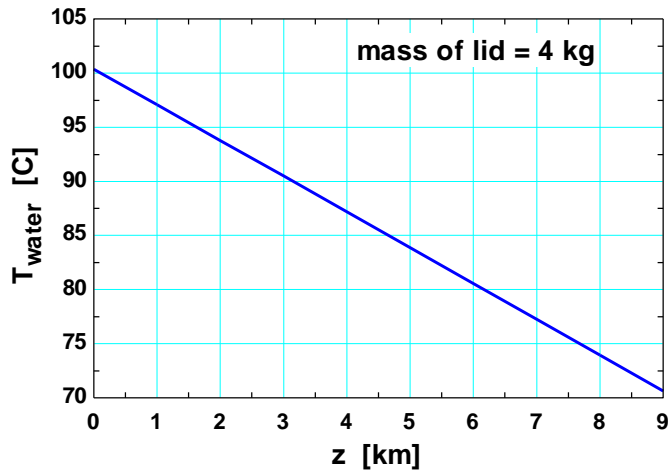

Effect of altitude on boiling temperature of water in pan with lid

3-48 A vertical piston-cylinder device is filled with water and covered with a 40-kg piston that serves as the lid. The boiling temperature of water is to be determined.

Analysis The pressure in the cylinder is determined from a force balance on the piston,

$$PA = P_{\text{atm}}A + W$$

or,

$$\begin{aligned} P &= P_{\text{atm}} + \frac{mg}{A} \\ &= (100 \text{ kPa}) + \frac{(40 \text{ kg})(9.81 \text{ m/s}^2)}{0.0150 \text{ m}^2} \left(\frac{1 \text{ kPa}}{1000 \text{ kg/m} \cdot \text{s}^2} \right) \\ &= 126.15 \text{ kPa} \end{aligned}$$

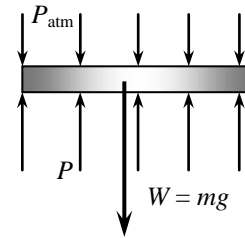

The boiling temperature is the saturation temperature corresponding to this pressure,

$$T = T_{\text{sat}@126.15\text{kPa}} = \mathbf{106.2^\circ\text{C}} \quad (\text{Table A-5})$$

3-49 Water is boiled in a pan by supplying electrical heat. The local atmospheric pressure is to be estimated.

Assumptions 75 percent of electricity consumed by the heater is transferred to the water.

Analysis The amount of heat transfer to the water during this period is

$$Q = fE_{\text{elect}} \text{ time} = (0.75)(2 \text{ kJ/s})(30 \times 60 \text{ s}) = 2700 \text{ kJ}$$

The enthalpy of vaporization is determined from

$$h_{fg} = \frac{Q}{m_{\text{boil}}} = \frac{2700 \text{ kJ}}{1.19 \text{ kg}} = 2269 \text{ kJ/kg}$$

Using the data by a trial-error approach in saturation table of water (Table A-5) or using EES as we did, the saturation pressure that corresponds to an enthalpy of vaporization value of 2269 kJ/kg is

$$P_{\text{sat}} = \mathbf{85.4 \text{ kPa}}$$

which is the local atmospheric pressure.

3-50 A rigid tank that is filled with saturated liquid-vapor mixture is heated. The temperature at which the liquid in the tank is completely vaporized is to be determined, and the T - ν diagram is to be drawn.

Analysis This is a constant volume process ($\nu = \mathbf{V}/m = \text{constant}$), and the specific volume is determined to be

$$\nu = \frac{\mathbf{V}}{m} = \frac{1.8 \text{ m}^3}{15 \text{ kg}} = 0.12 \text{ m}^3/\text{kg}$$

When the liquid is completely vaporized the tank will contain saturated vapor only. Thus,

$$\nu_2 = \nu_g = 0.12 \text{ m}^3/\text{kg}$$

The temperature at this point is the temperature that corresponds to this ν_g value,

$$T = T_{\text{sat}@ \nu_g = 0.12 \text{ m}^3/\text{kg}} = \mathbf{202.9^\circ\text{C}} \quad (\text{Table A-4})$$

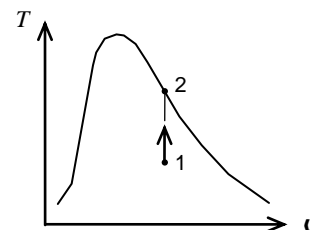
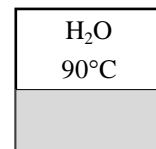



3-51 A piston-cylinder device contains a saturated liquid-vapor mixture of water at 800 kPa pressure. The mixture is heated at constant pressure until the temperature rises to 200°C. The initial temperature, the total mass of water, the final volume are to be determined, and the P - ν diagram is to be drawn.

Analysis (a) Initially two phases coexist in equilibrium, thus we have a saturated liquid-vapor mixture. Then the temperature in the tank must be the saturation temperature at the specified pressure,

$$T = T_{\text{sat}@600\text{kPa}} = \mathbf{158.8^\circ\text{C}}$$

(b) The total mass in this case can easily be determined by adding the mass of each phase,

$$m_f = \frac{\nu_f}{\nu_f} = \frac{0.005 \text{ m}^3}{0.001101 \text{ m}^3/\text{kg}} = 4.543 \text{ kg}$$

$$m_g = \frac{\nu_g}{\nu_g} = \frac{0.9 \text{ m}^3}{0.3156 \text{ m}^3/\text{kg}} = 2.852 \text{ kg}$$

$$m_t = m_f + m_g = 4.543 + 2.852 = \mathbf{7.395 \text{ kg}}$$

(c) At the final state water is superheated vapor, and its specific volume is

$$\left. \begin{array}{l} P_2 = 600 \text{ kPa} \\ T_2 = 200^\circ \text{C} \end{array} \right\} \nu_2 = 0.3521 \text{ m}^3/\text{kg} \quad (\text{Table A-6})$$

Then,

$$\nu_2 = m_t \nu_2 = (7.395 \text{ kg})(0.3521 \text{ m}^3/\text{kg}) = \mathbf{2.604 \text{ m}^3}$$

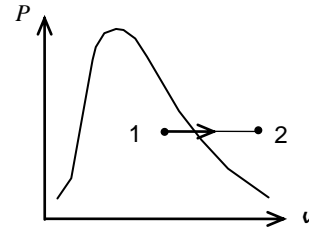



3-52 Prob. 3-51 is reconsidered. The effect of pressure on the total mass of water in the tank as the pressure varies from 0.1 MPa to 1 MPa is to be investigated. The total mass of water is to be plotted against pressure, and results are to be discussed.

Analysis The problem is solved using EES, and the solution is given below.

```

P[1]=600 [kPa]
P[2]=P[1]
T[2]=200 [C]
V_f1 = 0.005 [m^3]
V_g1=0.9 [m^3]
spvsat_f1=volume(Steam_iapws, P=P[1],x=0) "sat. liq. specific volume, m^3/kg"
spvsat_g1=volume(Steam_iapws,P=P[1],x=1) "sat. vap. specific volume, m^3/kg"
m_f1=V_f1/spvsat_f1 "sat. liq. mass, kg"
m_g1=V_g1/spvsat_g1 "sat. vap. mass, kg"
m_tot=m_f1+m_g1
V[1]=V_f1+V_g1
spvol[1]=V[1]/m_tot "specific volume1, m^3"
T[1]=temperature(Steam_iapws, P=P[1],v=spvol[1])"C"
"The final volume is calculated from the specific volume at the final T and P"
spvol[2]=volume(Steam_iapws, P=P[2], T=T[2]) "specific volume2, m^3/kg"
V[2]=m_tot*spvol[2]
  
```

P_1 [kPa]	m_{tot} [kg]
100	5.324
200	5.731
300	6.145
400	6.561
500	6.978
600	7.395
700	7.812
800	8.23
900	8.648
1000	9.066

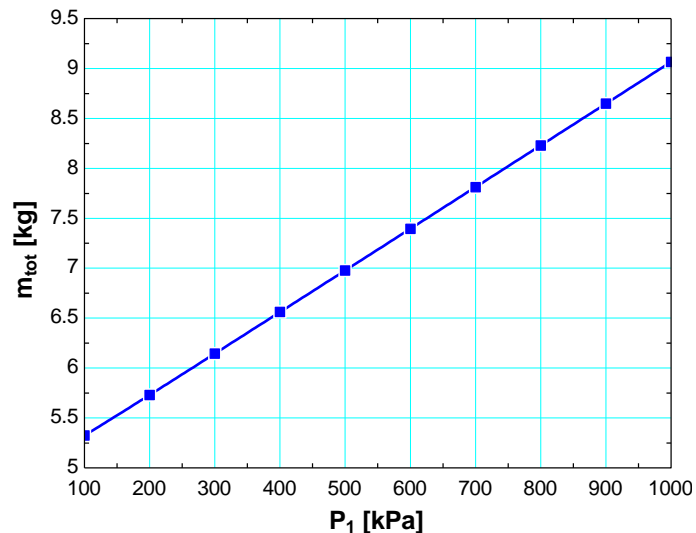
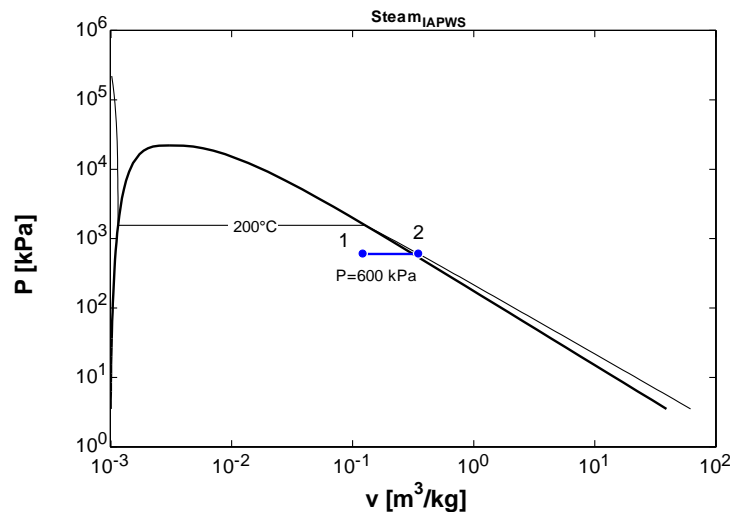

3-53E A rigid tank contains water at a specified pressure. The temperature, total enthalpy, and the mass of each phase are to be determined.

Analysis (a) The specific volume of the water is

$$v = \frac{V}{m} = \frac{5 \text{ ft}^3}{5 \text{ lbm}} = 1.0 \text{ ft}^3/\text{lbm}$$

At 20 psia, $v_f = 0.01683 \text{ ft}^3/\text{lbm}$ and $v_g = 20.093 \text{ ft}^3/\text{lbm}$ (Table A-12E). Thus the tank contains saturated liquid-vapor mixture since $v_f < v < v_g$, and the temperature must be the saturation temperature at the specified pressure,

$$T = T_{\text{sat}@20 \text{ psia}} = \mathbf{227.92^\circ\text{F}}$$

(b) The quality of the water and its total enthalpy are determined from

$$x = \frac{v - v_f}{v_{fg}} = \frac{1.0 - 0.01683}{20.093 - 0.01683} = 0.04897$$

$$h = h_f + xh_{fg} = 196.27 + 0.04897 \times 959.93 = 243.28 \text{ Btu/lbm}$$

$$H = mh = (5 \text{ lbm})(243.28 \text{ Btu/lbm}) = \mathbf{1216.4 \text{ Btu}}$$

(c) The mass of each phase is determined from

$$m_g = xm_t = 0.04897 \times 5 = \mathbf{0.245 \text{ lbm}}$$

$$m_f = m_t - m_g = 5 - 0.245 = \mathbf{4.755 \text{ lbm}}$$

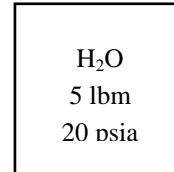

3-54E A rigid tank contains saturated liquid-vapor mixture of R-134a. The quality and total mass of the refrigerant are to be determined.

Analysis At 50 psia, $v_f = 0.01252 \text{ ft}^3/\text{lbm}$ and $v_g = 0.94791 \text{ ft}^3/\text{lbm}$ (Table A-12E). The volume occupied by the liquid and the vapor phases are

$$V_f = 1 \text{ ft}^3 \quad \text{and} \quad V_g = 4 \text{ ft}^3$$

Thus the mass of each phase is

$$m_f = \frac{V_f}{v_f} = \frac{1 \text{ ft}^3}{0.01252 \text{ ft}^3/\text{lbm}} = 79.88 \text{ lbm}$$

$$m_g = \frac{V_g}{v_g} = \frac{4 \text{ ft}^3}{0.94909 \text{ ft}^3/\text{lbm}} = 4.22 \text{ lbm}$$

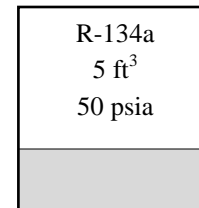

Then the total mass and the quality of the refrigerant are

$$m_t = m_f + m_g = 79.88 + 4.22 = \mathbf{84.10 \text{ lbm}}$$

$$x = \frac{m_g}{m_t} = \frac{4.22 \text{ lbm}}{84.10 \text{ lbm}} = \mathbf{0.05018}$$

3-55E Superheated water vapor cools at constant volume until the temperature drops to 250°F. At the final state, the pressure, the quality, and the enthalpy are to be determined.

Analysis This is a constant volume process ($v = V/m = \text{constant}$), and the initial specific volume is determined to be

$$\left. \begin{array}{l} P_1 = 180 \text{ psia} \\ T_1 = 500^\circ \text{F} \end{array} \right\} v_1 = 3.0433 \text{ ft}^3/\text{lbm} \quad (\text{Table A-6E})$$

At 250°F, $v_f = 0.01700 \text{ ft}^3/\text{lbm}$ and $v_g = 13.816 \text{ ft}^3/\text{lbm}$. Thus at the final state, the tank will contain saturated liquid-vapor mixture since $v_f < v < v_g$, and the final pressure must be the saturation pressure at the final temperature,

$$P = P_{\text{sat}@250^\circ\text{F}} = \mathbf{29.84 \text{ psia}}$$

(b) The quality at the final state is determined from

$$x_2 = \frac{v_2 - v_f}{v_{fg}} = \frac{3.0433 - 0.01700}{13.816 - 0.01700} = \mathbf{0.219}$$

(c) The enthalpy at the final state is determined from

$$h = h_f + xh_{fg} = 218.63 + 0.219 \times 945.41 = \mathbf{426.0 \text{ Btu/lbm}}$$

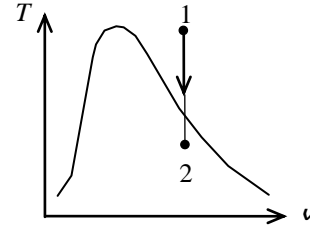
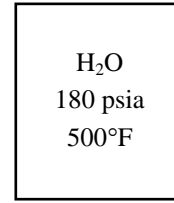



3-56E Problem 3-55E is reconsidered. The effect of initial pressure on the quality of water at the final state as the pressure varies from 100 psi to 300 psi is to be investigated. The quality is to be plotted against initial pressure, and the results are to be discussed.

Analysis The problem is solved using EES, and the solution is given below.

```
T[1]=500 [F]
P[1]=180 [psia]
T[2]=250 [F]
v[1]=volume(steam_iapws,T=T[1],P=P[1])
v[2]=v[1]
P[2]=pressure(steam_iapws,T=T[2],v=v[2])
h[2]=enthalpy(steam_iapws,T=T[2],v=v[2])
x[2]=quality(steam_iapws,T=T[2],v=v[2])
```

P_1 [psia]	x_2
100	0.4037
122.2	0.3283
144.4	0.2761
166.7	0.2378
188.9	0.2084
211.1	0.1853
233.3	0.1665
255.6	0.151
277.8	0.1379
300	0.1268

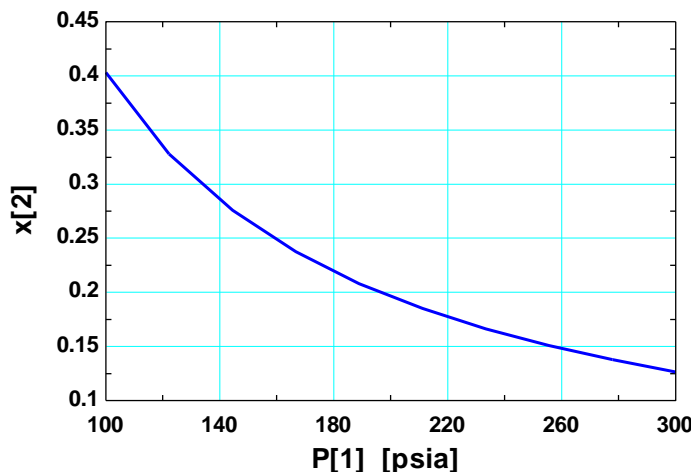
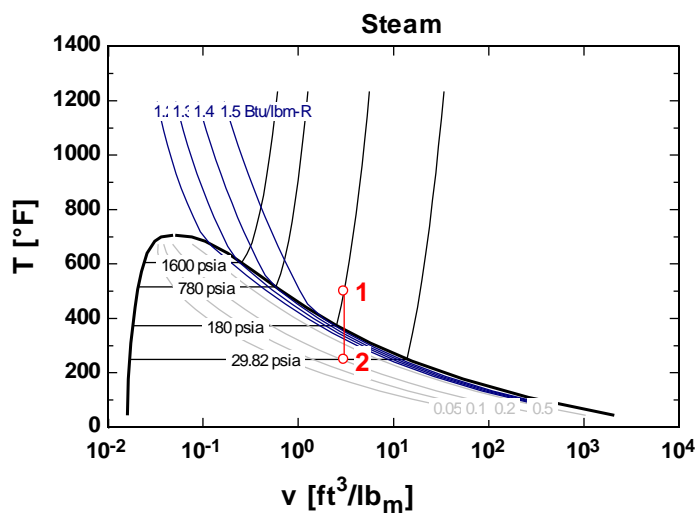

3-57 Superheated steam in a piston-cylinder device is cooled at constant pressure until half of the mass condenses. The final temperature and the volume change are to be determined, and the process should be shown on a T - ν diagram.

Analysis (b) At the final state the cylinder contains saturated liquid-vapor mixture, and thus the final temperature must be the saturation temperature at the final pressure,

$$T = T_{\text{sat}@0.5 \text{ MPa}} = \mathbf{151.83^\circ\text{C}} \quad (\text{Table A-5})$$

(c) The quality at the final state is specified to be $x_2 = 0.5$. The specific volumes at the initial and the final states are

$$\left. \begin{array}{l} P_1 = 0.5 \text{ MPa} \\ T_1 = 200^\circ\text{C} \end{array} \right\} \nu_1 = 0.42503 \text{ m}^3/\text{kg} \quad (\text{Table A-6})$$

$$\left. \begin{array}{l} P_2 = 0.5 \text{ MPa} \\ x_2 = 0.5 \end{array} \right\} \begin{aligned} \nu_2 &= \nu_f + x_2 \nu_{fg} \\ &= 0.001093 + 0.5 \times (0.37483 - 0.001093) \\ &= 0.1880 \text{ m}^3/\text{kg} \end{aligned}$$

Thus,

$$\Delta V = m(\nu_2 - \nu_1) = (0.6 \text{ kg})(0.1880 - 0.42503) \text{ m}^3/\text{kg} = \mathbf{-0.14222 \text{ m}^3}$$

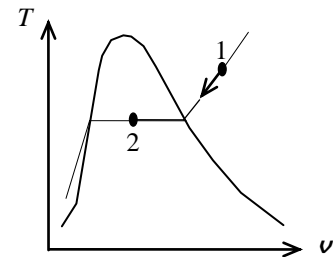
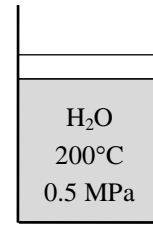

3-58 The water in a rigid tank is cooled until the vapor starts condensing. The initial pressure in the tank is to be determined.

Analysis This is a constant volume process ($\nu = V/m = \text{constant}$), and the initial specific volume is equal to the final specific volume that is

$$\nu_1 = \nu_2 = \nu_{g@12^\circ\text{F}} = 0.79270 \text{ m}^3/\text{kg} \quad (\text{Table A-4})$$

since the vapor starts condensing at 150°C . Then from Table A-6,

$$\left. \begin{array}{l} T_1 = 250^\circ\text{C} \\ \nu_1 = 0.79270 \text{ m}^3/\text{kg} \end{array} \right\} P_1 = \mathbf{0.30 \text{ MPa}}$$

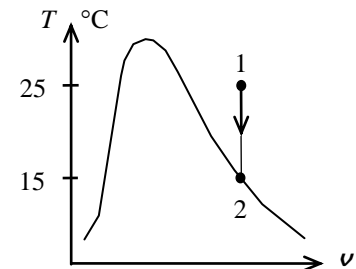
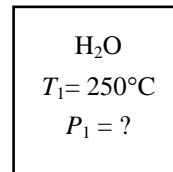

3-59 Heat is supplied to a piston-cylinder device that contains water at a specified state. The volume of the tank, the final temperature and pressure, and the internal energy change of water are to be determined.

Properties The saturated liquid properties of water at 200°C are: $\nu_f = 0.001157 \text{ m}^3/\text{kg}$ and $u_f = 850.46 \text{ kJ/kg}$ (Table A-4).

Analysis (a) The cylinder initially contains saturated liquid water. The volume of the cylinder at the initial state is

$$\nu_1 = m\nu_1 = (1.4 \text{ kg})(0.001157 \text{ m}^3/\text{kg}) = 0.001619 \text{ m}^3$$

The volume at the final state is

$$\nu = 4(0.001619) = \mathbf{0.006476 \text{ m}^3}$$

(b) The final state properties are

$$\nu_2 = \frac{\nu}{m} = \frac{0.006476 \text{ m}^3}{1.4 \text{ kg}} = 0.004626 \text{ m}^3/\text{kg}$$

$$\left. \begin{array}{l} \nu_2 = 0.004626 \text{ m}^3/\text{kg} \\ x_2 = 1 \end{array} \right\} \begin{array}{l} T_2 = \mathbf{371.3^\circ\text{C}} \\ P_2 = \mathbf{21,367 \text{ kPa}} \\ u_2 = 2201.5 \text{ kJ/kg} \end{array} \quad (\text{Table A-4 or A-5 or EES})$$

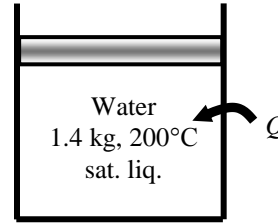

(c) The total internal energy change is determined from

$$\Delta U = m(u_2 - u_1) = (1.4 \text{ kg})(2201.5 - 850.46) \text{ kJ/kg} = \mathbf{1892 \text{ kJ}}$$

3-60E The error involved in using the enthalpy of water by the incompressible liquid approximation is to be determined.

Analysis The state of water is compressed liquid. From the steam tables,

$$\left. \begin{array}{l} P = 3000 \text{ psia} \\ T = 400^\circ\text{F} \end{array} \right\} h = 378.41 \text{ Btu/lbm} \quad (\text{Table A - 7E})$$

Based upon the incompressible liquid approximation,

$$\left. \begin{array}{l} P = 3000 \text{ psia} \\ T = 400^\circ\text{F} \end{array} \right\} h \cong h_f @ 400^\circ\text{F} = 375.04 \text{ Btu/lbm} \quad (\text{Table A - 4E})$$

The error involved is

$$\text{Percent Error} = \frac{378.41 - 375.04}{378.41} \times 100 = \mathbf{0.89\%}$$

which is quite acceptable in most engineering calculations.

3-61 A piston-cylinder device that is filled with R-134a is heated. The volume change is to be determined.

Analysis The initial specific volume is

$$\left. \begin{array}{l} P_1 = 60 \text{ kPa} \\ T_1 = -20^\circ\text{C} \end{array} \right\} \nu_1 = 0.33608 \text{ m}^3/\text{kg} \text{ (Table A-13)}$$

and the initial volume is

$$V_1 = m\nu_1 = (0.100 \text{ kg})(0.33608 \text{ m}^3/\text{kg}) = 0.033608 \text{ m}^3$$

At the final state, we have

$$\left. \begin{array}{l} P_2 = 60 \text{ kPa} \\ T_2 = 100^\circ\text{C} \end{array} \right\} \nu_2 = 0.50410 \text{ m}^3/\text{kg} \text{ (Table A-13)}$$

$$V_2 = m\nu_2 = (0.100 \text{ kg})(0.50410 \text{ m}^3/\text{kg}) = 0.050410 \text{ m}^3$$

The volume change is then

$$\Delta V = V_2 - V_1 = 0.050410 - 0.033608 = \mathbf{0.0168 \text{ m}^3}$$

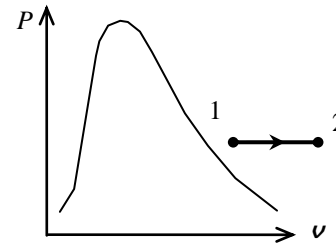
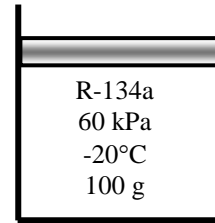

3-62 A rigid vessel is filled with refrigerant-134a. The total volume and the total internal energy are to be determined.

Properties The properties of R-134a at the given state are (Table A-13).

$$\left. \begin{array}{l} P = 500 \text{ kPa} \\ T = 120^\circ\text{C} \end{array} \right\} \begin{array}{l} u = 329.91 \text{ kJ/kg} \\ \nu = 0.061687 \text{ m}^3/\text{kg} \end{array}$$

Analysis The total volume and internal energy are determined from

$$V = m\nu = (8 \text{ kg})(0.061687 \text{ m}^3/\text{kg}) = \mathbf{0.494 \text{ m}^3}$$

$$U = mu = (8 \text{ kg})(329.91 \text{ kJ/kg}) = \mathbf{2639 \text{ kJ}}$$

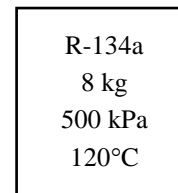

3-63 Heat is supplied to a rigid tank that contains water at a specified state. The volume of the tank, the final temperature and pressure, and the internal energy change of water are to be determined.

Properties The saturated liquid properties of water at 200°C are: $\nu_f = 0.001157 \text{ m}^3/\text{kg}$ and $u_f = 850.46 \text{ kJ/kg}$ (Table A-4).

Analysis (a) The tank initially contains saturated liquid water and air. The volume occupied by water is

$$\nu_1 = m\nu_f = (1.4 \text{ kg})(0.001157 \text{ m}^3/\text{kg}) = 0.001619 \text{ m}^3$$

which is the 25 percent of total volume. Then, the total volume is determined from

$$\nu = \frac{1}{0.25} (0.001619) = \mathbf{0.006476 \text{ m}^3}$$

(b) Properties after the heat addition process are

$$\nu_2 = \frac{\nu}{m} = \frac{0.006476 \text{ m}^3}{1.4 \text{ kg}} = 0.004626 \text{ m}^3/\text{kg}$$

$$\left. \begin{array}{l} \nu_2 = 0.004626 \text{ m}^3/\text{kg} \\ x_2 = 1 \end{array} \right\} \begin{array}{l} T_2 = \mathbf{371.3^\circ\text{C}} \\ P_2 = \mathbf{21,367 \text{ kPa}} \\ u_2 = 2201.5 \text{ kJ/kg} \end{array} \quad (\text{Table A-4 or A-5 or EES})$$

(c) The total internal energy change is determined from

$$\Delta U = m(u_2 - u_1) = (1.4 \text{ kg})(2201.5 - 850.46) \text{ kJ/kg} = \mathbf{1892 \text{ kJ}}$$

3-64 A piston-cylinder device that is initially filled with water is heated at constant pressure until all the liquid has vaporized. The mass of water, the final temperature, and the total enthalpy change are to be determined, and the T - ν diagram is to be drawn.

Analysis Initially the cylinder contains compressed liquid (since $P > P_{\text{sat}@40^\circ\text{C}}$) that can be approximated as a saturated liquid at the specified temperature (Table A-4),

$$\nu_1 \cong \nu_{f@40^\circ\text{C}} = 0.001008 \text{ m}^3/\text{kg}$$

$$h_1 \cong h_{f@40^\circ\text{C}} = 167.53 \text{ kJ/kg}$$

(a) The mass is determined from

$$m = \frac{\nu_1}{\nu_f} = \frac{0.050 \text{ m}^3}{0.001008 \text{ m}^3/\text{kg}} = \mathbf{49.61 \text{ kg}}$$

(b) At the final state, the cylinder contains saturated vapor and thus the final temperature must be the saturation temperature at the final pressure,

$$T = T_{\text{sat}@200 \text{ kPa}} = \mathbf{120.21^\circ\text{C}}$$

(c) The final enthalpy is $h_2 = h_{g@200 \text{ kPa}} = 2706.3 \text{ kJ/kg}$. Thus,

$$\Delta H = m(h_2 - h_1) = (49.61 \text{ kg})(2706.3 - 167.53) \text{ kJ/kg} = \mathbf{125,950 \text{ kJ}}$$

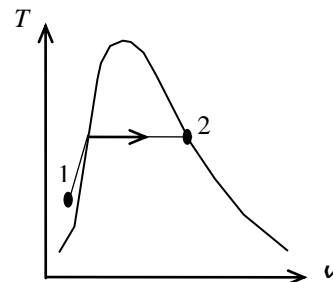
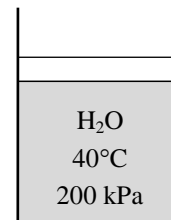

Ideal Gas

3-65C A gas can be treated as an ideal gas when it is at a high temperature or low pressure relative to its critical temperature and pressure.

3-66C R_u is the universal gas constant that is the same for all gases whereas R is the specific gas constant that is different for different gases. These two are related to each other by $R = R_u / M$, where M is the molar mass of the gas.

3-67C Propane (molar mass = 44.1 kg/kmol) poses a greater fire danger than methane (molar mass = 16 kg/kmol) since propane is heavier than air (molar mass = 29 kg/kmol), and it will settle near the floor. Methane, on the other hand, is lighter than air and thus it will rise and leak out.

3-68 A rigid tank contains air at a specified state. The gage pressure of the gas in the tank is to be determined.

Assumptions At specified conditions, air behaves as an ideal gas.

Properties The gas constant of air is $R = 0.287 \text{ kPa}\cdot\text{m}^3/\text{kg}\cdot\text{K}$ (Table A-1).

Analysis Treating air as an ideal gas, the absolute pressure in the tank is determined from

$$P = \frac{mRT}{V} = \frac{(5 \text{ kg})(0.287 \text{ kPa}\cdot\text{m}^3/\text{kg}\cdot\text{K})(298 \text{ K})}{0.4 \text{ m}^3} = 1069.1 \text{ kPa}$$

Thus the gage pressure is

$$P_g = P - P_{\text{atm}} = 1069.1 - 97 = \mathbf{972.1 \text{ kPa}}$$

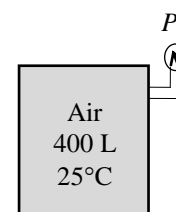

3-69E The temperature in a container that is filled with oxygen is to be determined.

Assumptions At specified conditions, oxygen behaves as an ideal gas.

Properties The gas constant of oxygen is $R = 0.3353 \text{ psia}\cdot\text{ft}^3/\text{lbm}\cdot\text{R}$ (Table A-1E).

Analysis The definition of the specific volume gives

$$v = \frac{V}{m} = \frac{3 \text{ ft}^3}{2 \text{ lbm}} = 1.5 \text{ ft}^3/\text{lbm}$$

Using the ideal gas equation of state, the temperature is

$$T = \frac{Pv}{R} = \frac{(80 \text{ psia})(1.5 \text{ ft}^3/\text{lbm})}{0.3353 \text{ psia}\cdot\text{ft}^3/\text{lbm}\cdot\text{R}} = \mathbf{358\text{R}}$$

3-70 The volume of a container that is filled with helium at a specified state is to be determined.

Assumptions At specified conditions, helium behaves as an ideal gas.

Properties The gas constant of helium is $R = 2.0769 \text{ kJ/kg}\cdot\text{K}$ (Table A-1).

Analysis According to the ideal gas equation of state,

$$V = \frac{mRT}{P} = \frac{(2 \text{ kg})(2.0769 \text{ kPa}\cdot\text{m}^3/\text{kg}\cdot\text{K})(27 + 273 \text{ K})}{300 \text{ kPa}} = \mathbf{4.154 \text{ m}^3}$$

3-71 The pressure and temperature of oxygen gas in a storage tank are given. The mass of oxygen in the tank is to be determined.

Assumptions At specified conditions, oxygen behaves as an ideal gas

Properties The gas constant of oxygen is $R = 0.2598 \text{ kPa}\cdot\text{m}^3/\text{kg}\cdot\text{K}$ (Table A-1).

Analysis The absolute pressure of O_2 is

$$P = P_g + P_{\text{atm}} = 500 + 97 = 597 \text{ kPa}$$

Treating O_2 as an ideal gas, the mass of O_2 in tank is determined to be

$$m = \frac{PV}{RT} = \frac{(597 \text{ kPa})(2.5 \text{ m}^3)}{(0.2598 \text{ kPa}\cdot\text{m}^3/\text{kg}\cdot\text{K})(28 + 273) \text{ K}} = \mathbf{19.08 \text{ kg}}$$

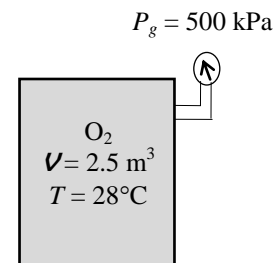

3-72 A balloon is filled with helium gas. The mole number and the mass of helium in the balloon are to be determined.

Assumptions At specified conditions, helium behaves as an ideal gas.

Properties The universal gas constant is $R_u = 8.314 \text{ kPa}\cdot\text{m}^3/\text{kmol}\cdot\text{K}$. The molar mass of helium is 4.0 kg/kmol (Table A-1).

Analysis The volume of the sphere is

$$V = \frac{4}{3} \pi r^3 = \frac{4}{3} \pi (4.5 \text{ m})^3 = 381.7 \text{ m}^3$$

Assuming ideal gas behavior, the mole numbers of He is determined from

$$N = \frac{PV}{R_u T} = \frac{(200 \text{ kPa})(381.7 \text{ m}^3)}{(8.314 \text{ kPa}\cdot\text{m}^3/\text{kmol}\cdot\text{K})(300 \text{ K})} = \mathbf{30.61 \text{ kmol}}$$

Then the mass of He can be determined from

$$m = NM = (30.61 \text{ kmol})(4.0 \text{ kg/kmol}) = \mathbf{123 \text{ kg}}$$

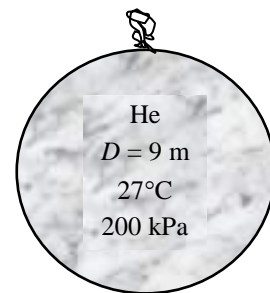



3-73 Problem 3-72 is to be reconsidered. The effect of the balloon diameter on the mass of helium contained in the balloon is to be determined for the pressures of (a) 100 kPa and (b) 200 kPa as the diameter varies from 5 m to 15 m. The mass of helium is to be plotted against the diameter for both cases.

Analysis The problem is solved using EES, and the solution is given below.

"Given Data"

{D=9 [m]}

T=27 [C]

P=200 [kPa]

R_u=8.314 [kJ/kmol-K]

"Solution"

$P*V=N*R_u*(T+273)$

$V=4*pi*(D/2)^3/3$

$m=N*MOLARMASS(Helium)$

D [m]	m [kg]
5	21.01
6.111	38.35
7.222	63.31
8.333	97.25
9.444	141.6
10.56	197.6
11.67	266.9
12.78	350.6
13.89	450.2
15	567.2

P=200 kPa

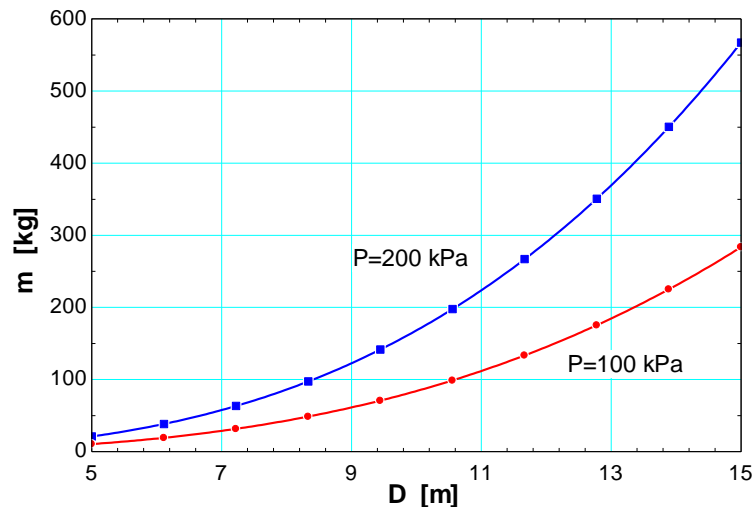

3-74E An automobile tire is under inflated with air. The amount of air that needs to be added to the tire to raise its pressure to the recommended value is to be determined.

Assumptions 1 At specified conditions, air behaves as an ideal gas. **2** The volume of the tire remains constant.

Properties The gas constant of air is $R = 0.3704 \text{ psia}\cdot\text{ft}^3/\text{lbm}\cdot\text{R}$ (Table A-1E).

Analysis The initial and final absolute pressures in the tire are

$$P_1 = P_{g1} + P_{\text{atm}} = 20 + 14.6 = 34.6 \text{ psia}$$

$$P_2 = P_{g2} + P_{\text{atm}} = 30 + 14.6 = 44.6 \text{ psia}$$

Treating air as an ideal gas, the initial mass in the tire is

$$m_1 = \frac{P_1 V}{RT_1} = \frac{(34.6 \text{ psia})(0.53 \text{ ft}^3)}{(0.3704 \text{ psia}\cdot\text{ft}^3/\text{lbm}\cdot\text{R})(550 \text{ R})} = 0.0900 \text{ lbm}$$

Noting that the temperature and the volume of the tire remain constant, the final mass in the tire becomes

$$m_2 = \frac{P_2 V}{RT_2} = \frac{(44.6 \text{ psia})(0.53 \text{ ft}^3)}{(0.3704 \text{ psia}\cdot\text{ft}^3/\text{lbm}\cdot\text{R})(550 \text{ R})} = 0.1160 \text{ lbm}$$

Thus the amount of air that needs to be added is

$$\Delta m = m_2 - m_1 = 0.1160 - 0.0900 = \mathbf{0.0260 \text{ lbm}}$$

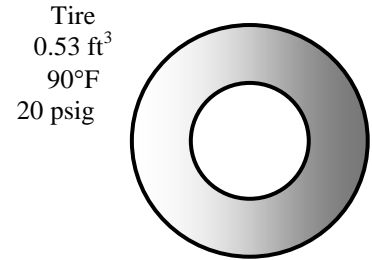

3-75 Two rigid tanks connected by a valve to each other contain air at specified conditions. The volume of the second tank and the final equilibrium pressure when the valve is opened are to be determined.

Assumptions At specified conditions, air behaves as an ideal gas.

Properties The gas constant of air is $R = 0.287 \text{ kPa}\cdot\text{m}^3/\text{kg}\cdot\text{K}$ (Table A-1).

Analysis Let's call the first and the second tanks A and B. Treating air as an ideal gas, the volume of the second tank and the mass of air in the first tank are determined to be

$$V_B = \left(\frac{m_1 R T_1}{P_1} \right)_B = \frac{(3 \text{ kg})(0.287 \text{ kPa}\cdot\text{m}^3/\text{kg}\cdot\text{K})(308 \text{ K})}{200 \text{ kPa}} = \mathbf{1.326 \text{ m}^3}$$

$$m_A = \left(\frac{P_1 V}{R T_1} \right)_A = \frac{(350 \text{ kPa})(1.0 \text{ m}^3)}{(0.287 \text{ kPa}\cdot\text{m}^3/\text{kg}\cdot\text{K})(283 \text{ K})} = 4.309 \text{ kg}$$

Thus,

$$V = V_A + V_B = 1.0 + 1.326 = 2.326 \text{ m}^3$$

$$m = m_A + m_B = 4.309 + 3 = 7.309 \text{ kg}$$

Then the final equilibrium pressure becomes

$$P_2 = \frac{m R T_2}{V} = \frac{(7.309 \text{ kg})(0.287 \text{ kPa}\cdot\text{m}^3/\text{kg}\cdot\text{K})(293 \text{ K})}{2.326 \text{ m}^3} = \mathbf{264 \text{ kPa}}$$

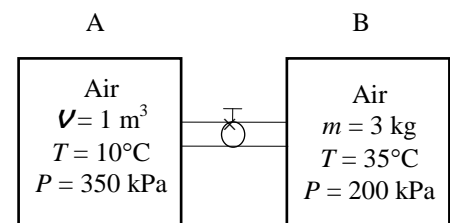

3-76 One side of a two-sided tank contains an ideal gas while the other side is evacuated. The partition is removed and the gas fills the entire tank. The gas is also heated to a final pressure. The final temperature is to be determined.

Assumptions The gas is specified as an ideal gas so that ideal gas relation can be used.

Analysis According to the ideal gas equation of state,

$$P_2 = P_1$$

$$V_2 = V_1 + 2V_1 = 3V_1$$

Applying these,

$$m_1 = m_2$$

$$\frac{P_1 V_1}{T_1} = \frac{P_2 V_2}{T_2}$$

$$\frac{V_1}{T_1} = \frac{V_2}{T_2}$$

$$T_2 = T_1 \frac{V_2}{V_1} = T_1 \frac{3V_1}{V_1} = 3T_1 = 3[927 + 273] \text{ K} = 3600 \text{ K} = \mathbf{3327^\circ\text{C}}$$

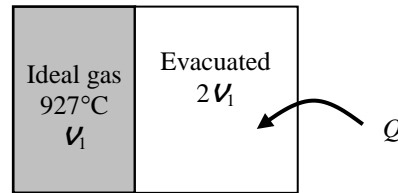

3-77 A piston-cylinder device containing argon undergoes an isothermal process. The final pressure is to be determined.

Assumptions At specified conditions, argon behaves as an ideal gas.

Properties The gas constant of argon is $R = 0.2081 \text{ kJ/kg}\cdot\text{K}$ (Table A-1).

Analysis Since the temperature remains constant, the ideal gas equation gives

$$m = \frac{P_1 V_1}{RT} = \frac{P_2 V_2}{RT} \longrightarrow P_1 V_1 = P_2 V_2$$

which when solved for final pressure becomes

$$P_2 = P_1 \frac{V_1}{V_2} = P_1 \frac{V_1}{2V_1} = 0.5P_1 = 0.5(550 \text{ kPa}) = \mathbf{275 \text{ kPa}}$$

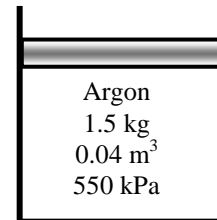

3-78E A rigid tank contains slightly pressurized air. The amount of air that needs to be added to the tank to raise its pressure and temperature to the recommended values is to be determined.

Assumptions **1** At specified conditions, air behaves as an ideal gas. **2** The volume of the tank remains constant.

Properties The gas constant of air is $R = 0.3704 \text{ psia}\cdot\text{ft}^3/\text{lbm}\cdot\text{R}$ (Table A-1E).

Analysis Treating air as an ideal gas, the initial volume and the final mass in the tank are determined to be

$$V = \frac{m_1 R T_1}{P_1} = \frac{(20 \text{ lbm})(0.3704 \text{ psia}\cdot\text{ft}^3/\text{lbm}\cdot\text{R})(530 \text{ R})}{20 \text{ psia}} = 196.3 \text{ ft}^3$$

$$m_2 = \frac{P_2 V}{R T_2} = \frac{(35 \text{ psia})(196.3 \text{ ft}^3)}{(0.3704 \text{ psia}\cdot\text{ft}^3/\text{lbm}\cdot\text{R})(550 \text{ R})} = 33.73 \text{ lbm}$$

Thus the amount of air added is

$$\Delta m = m_2 - m_1 = 33.73 - 20.0 = \mathbf{13.73 \text{ lbm}}$$

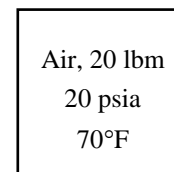

Compressibility Factor

3-79C All gases have the same compressibility factor Z at the same reduced temperature and pressure.

3-80C Reduced pressure is the pressure normalized with respect to the critical pressure; and reduced temperature is the temperature normalized with respect to the critical temperature.

3-81E The temperature of R-134a is to be determined using the ideal gas relation, the compressibility chart, and the R-134a tables.

Properties The gas constant, the critical pressure, and the critical temperature of refrigerant-134a are, from Table A-1E,

$$R = 0.10517 \text{ psia} \cdot \text{ft}^3/\text{lbm} \cdot \text{R}, \quad T_{cr} = 673.6 \text{ R}, \quad P_{cr} = 588.7 \text{ psia}$$

Analysis (a) From the ideal gas equation of state,

$$T = \frac{P\nu}{R} = \frac{(400 \text{ psia})(0.1384 \text{ ft}^3/\text{lbm})}{(0.10517 \text{ psia} \cdot \text{ft}^3/\text{lbm} \cdot \text{R})} = \mathbf{526 \text{ R}}$$

(b) From the compressibility chart (Fig. A-15a),

$$\left. \begin{aligned} P_R &= \frac{P}{P_{cr}} = \frac{400 \text{ psia}}{588.7 \text{ psia}} = 0.679 \\ \nu_R &= \frac{\nu_{\text{actual}}}{RT_{cr}/P_{cr}} = \frac{(0.1384 \text{ ft}^3/\text{lbm})(588.7 \text{ psia})}{(0.10517 \text{ psia} \cdot \text{ft}^3/\text{lbm} \cdot \text{R})(673.6 \text{ R})} = 1.15 \end{aligned} \right\} T_R = 1.03$$

Thus,

$$T = T_R T_{cr} = 1.03 \times 673.6 = \mathbf{694 \text{ R}}$$

(c) From the superheated refrigerant table (Table A-13E),

$$\left. \begin{aligned} P &= 400 \text{ psia} \\ \nu &= 0.1384 \text{ ft}^3/\text{lbm} \end{aligned} \right\} T = 240^\circ\text{F} \quad (\mathbf{700 \text{ R}})$$

3-82 The specific volume of steam is to be determined using the ideal gas relation, the compressibility chart, and the steam tables. The errors involved in the first two approaches are also to be determined.

Properties The gas constant, the critical pressure, and the critical temperature of water are, from Table A-1,

$$R = 0.4615 \text{ kPa} \cdot \text{m}^3/\text{kg} \cdot \text{K}, \quad T_{cr} = 647.1 \text{ K}, \quad P_{cr} = 22.06 \text{ MPa}$$

Analysis (a) From the ideal gas equation of state,

$$\nu = \frac{RT}{P} = \frac{(0.4615 \text{ kPa} \cdot \text{m}^3/\text{kg} \cdot \text{K})(623.15 \text{ K})}{15,000 \text{ kPa}} = \mathbf{0.01917 \text{ m}^3/\text{kg} \text{ (67.0\% error)}}$$

(b) From the compressibility chart (Fig. A-15),

$$\left. \begin{aligned} P_R &= \frac{P}{P_{cr}} = \frac{10 \text{ MPa}}{22.06 \text{ MPa}} = 0.453 \\ T_R &= \frac{T}{T_{cr}} = \frac{673 \text{ K}}{647.1 \text{ K}} = 1.04 \end{aligned} \right\} Z = 0.65$$

<p>H₂O 15 MPa 350°C</p>
--

Thus,

$$\nu = Z\nu_{ideal} = (0.65)(0.01917 \text{ m}^3/\text{kg}) = \mathbf{0.01246 \text{ m}^3/\text{kg} \text{ (8.5\% error)}}$$

(c) From the superheated steam table (Table A-6),

$$\left. \begin{aligned} P &= 15 \text{ MPa} \\ T &= 350^\circ\text{C} \end{aligned} \right\} \nu = \mathbf{0.01148 \text{ m}^3/\text{kg}}$$



3-83 Problem 3-82 is reconsidered. The problem is to be solved using the general compressibility factor feature of EES (or other) software. The specific volume of water for the three cases at 15 MPa over the temperature range of 350°C to 600°C in 25°C intervals is to be compared, and the % error involved in the ideal gas approximation is to be plotted against temperature.

Analysis The problem is solved using EES, and the solution is given below.

```

P=15 [MPa]*Convert(MPa,kPa)
{T_Celsius= 350 [C]}
T=T_Celsius+273 "[K]"
T_critical=T_CRIT(Steam_iapws)
P_critical=P_CRIT(Steam_iapws)
{v=Vol/m}
P_table=P; P_comp=P;P_idealgas=P
T_table=T; T_comp=T;T_idealgas=T
v_table=volume(Steam_iapws,P=P_table,T=T_table) "EES data for steam as a real gas"
{P_table=pressure(Steam_iapws, T=T_table,v=v)}
{T_sat=temperature(Steam_iapws,P=P_table,v=v)}
MM=MOLARMASS(water)
R_u=8.314 [kJ/kmol-K] "Universal gas constant"
R=R_u/MM "[kJ/kg-K], Particular gas constant"
P_idealgas*v_idealgas=R*T_idealgas "Ideal gas equation"
z = COMPRESS(T_comp/T_critical,P_comp/P_critical)
P_comp*v_comp=z*R*T_comp "generalized Compressibility factor"
Error_idealgas=Abs(v_table-v_idealgas)/v_table*Convert(, %)
Error_comp=Abs(v_table-v_comp)/v_table*Convert(, %)
  
```

Error _{comp} [%]	Error _{ideal gas} [%]	T _{Celsius} [C]
9.447	67.22	350
2.725	43.53	375
0.4344	32.21	400
0.5995	25.23	425
1.101	20.44	450
1.337	16.92	475
1.428	14.22	500
1.437	12.1	525
1.397	10.39	550
1.329	8.976	575
1.245	7.802	600

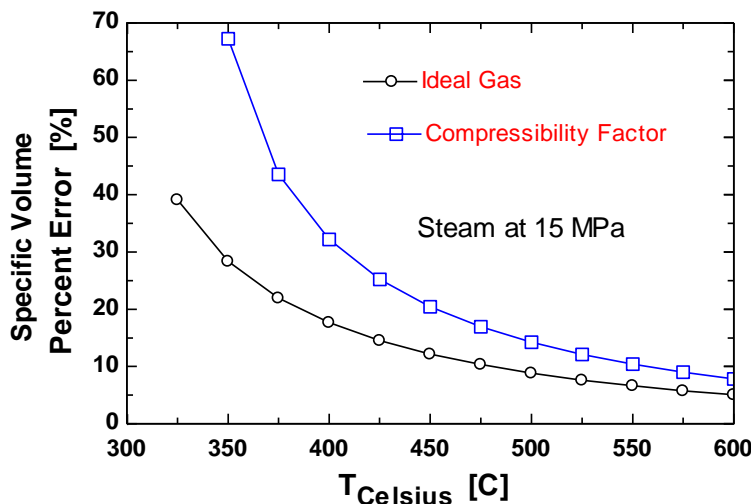

3-84 The specific volume of steam is to be determined using the ideal gas relation, the compressibility chart, and the steam tables. The errors involved in the first two approaches are also to be determined.

Properties The gas constant, the critical pressure, and the critical temperature of water are, from Table A-1,

$$R = 0.4615 \text{ kPa} \cdot \text{m}^3/\text{kg} \cdot \text{K}, \quad T_{cr} = 647.1 \text{ K}, \quad P_{cr} = 22.06 \text{ MPa}$$

Analysis (a) From the ideal gas equation of state,

$$\nu = \frac{RT}{P} = \frac{(0.4615 \text{ kPa} \cdot \text{m}^3/\text{kg} \cdot \text{K})(723 \text{ K})}{3500 \text{ kPa}} = \mathbf{0.09533 \text{ m}^3/\text{kg}} \quad \mathbf{(3.7\% \text{ error})}$$

(b) From the compressibility chart (Fig. A-15),

$$\left. \begin{aligned} P_R &= \frac{P}{P_{cr}} = \frac{3.5 \text{ MPa}}{22.06 \text{ MPa}} = 0.159 \\ T_R &= \frac{T}{T_{cr}} = \frac{723 \text{ K}}{647.1 \text{ K}} = 1.12 \end{aligned} \right\} Z = 0.961$$

<p style="text-align: center;">H₂O 3.5 MPa 450°C</p>

Thus,

$$\nu = Z\nu_{ideal} = (0.961)(0.09533 \text{ m}^3/\text{kg}) = \mathbf{0.09161 \text{ m}^3/\text{kg}} \quad \mathbf{(0.4\% \text{ error})}$$

(c) From the superheated steam table (Table A-6),

$$\left. \begin{aligned} P &= 3.5 \text{ MPa} \\ T &= 450^\circ\text{C} \end{aligned} \right\} \nu = \mathbf{0.09196 \text{ m}^3/\text{kg}}$$

3-85 Somebody claims that oxygen gas at a specified state can be treated as an ideal gas with an error less than 10%. The validity of this claim is to be determined.

Properties The critical pressure, and the critical temperature of oxygen are, from Table A-1,

$$T_{cr} = 154.8 \text{ K} \quad \text{and} \quad P_{cr} = 5.08 \text{ MPa}$$

Analysis From the compressibility chart (Fig. A-15),

$$\left. \begin{aligned} P_R &= \frac{P}{P_{cr}} = \frac{3 \text{ MPa}}{5.08 \text{ MPa}} = 0.591 \\ T_R &= \frac{T}{T_{cr}} = \frac{160 \text{ K}}{154.8 \text{ K}} = 1.034 \end{aligned} \right\} Z = 0.79$$

<p style="text-align: center;">O₂ 3 MPa 160 K</p>
--

Then the error involved can be determined from

$$\text{Error} = \frac{\nu - \nu_{ideal}}{\nu} = 1 - \frac{1}{Z} = 1 - \frac{1}{0.79} = -26.6\%$$

Thus the claim is **false**.

3-86E Ethane in a rigid vessel is heated. The final pressure is to be determined using the compressibility chart.

Properties The gas constant, the critical pressure, and the critical temperature of ethane are, from Table A-1E,

$$R = 0.3574 \text{ psia} \cdot \text{ft}^3/\text{lbm} \cdot \text{R}, \quad T_{\text{cr}} = 549.8 \text{ R}, \quad P_{\text{cr}} = 708 \text{ psia}$$

Analysis From the compressibility chart at the initial state (from Fig. A-15 or EES. We used EES throughout the solution.),

$$\left. \begin{aligned} T_{R1} &= \frac{T_1}{T_{\text{cr}}} = \frac{560 \text{ R}}{549.8 \text{ R}} = 1.019 \\ P_{R1} &= \frac{P_1}{P_{\text{cr}}} = \frac{50 \text{ psia}}{708 \text{ psia}} = 0.0706 \end{aligned} \right\} Z_1 = 0.977$$

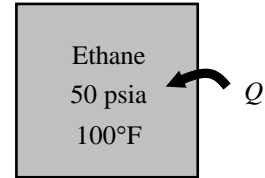

The specific volume does not change during the process. Then,

$$\nu_1 = \nu_2 = \frac{Z_1 R T_1}{P_1} = \frac{(0.977)(0.3574 \text{ psia} \cdot \text{ft}^3/\text{lbm} \cdot \text{R})(560 \text{ R})}{50 \text{ psia}} = 3.91 \text{ ft}^3/\text{lbm}$$

At the final state,

$$\left. \begin{aligned} T_{R2} &= \frac{T_2}{T_{\text{cr}}} = \frac{1000 \text{ R}}{549.8 \text{ R}} = 1.819 \\ \nu_{R2} &= \frac{\nu_{2,\text{actual}}}{RT_{\text{cr}}/P_{\text{cr}}} = \frac{3.91 \text{ ft}^3/\text{lbm}}{(0.3574 \text{ psia} \cdot \text{ft}^3/\text{lbm} \cdot \text{R})(549.8 \text{ R})/(708 \text{ psia})} = 14.1 \end{aligned} \right\} Z_2 = 1.0$$

Thus,

$$P_2 = \frac{Z_2 R T_2}{\nu_2} = \frac{(1.0)(0.3574 \text{ psia} \cdot \text{ft}^3/\text{lbm} \cdot \text{R})(1000 \text{ R})}{3.91 \text{ ft}^3/\text{lbm}} = \mathbf{91.4 \text{ psia}}$$

3-87 Ethylene is heated at constant pressure. The specific volume change of ethylene is to be determined using the compressibility chart.

Properties The gas constant, the critical pressure, and the critical temperature of ethane are, from Table A-1,

$$R = 0.2964 \text{ kPa} \cdot \text{m}^3/\text{kg} \cdot \text{K}, \quad T_{\text{cr}} = 282.4 \text{ K}, \quad P_{\text{cr}} = 5.12 \text{ MPa}$$

Analysis From the compressibility chart at the initial and final states (Fig. A-15),

$$\left. \begin{aligned} T_{R1} &= \frac{T_1}{T_{\text{cr}}} = \frac{293 \text{ K}}{282.4 \text{ K}} = 1.038 \\ P_{R1} &= \frac{P_1}{P_{\text{cr}}} = \frac{5 \text{ MPa}}{5.12 \text{ MPa}} = 0.977 \end{aligned} \right\} Z_1 = 0.56$$

$$\left. \begin{aligned} T_{R2} &= \frac{T_2}{T_{\text{cr}}} = \frac{473 \text{ K}}{282.4 \text{ K}} = 1.675 \\ P_{R2} &= P_{R1} = 0.977 \end{aligned} \right\} Z_2 = 0.961$$

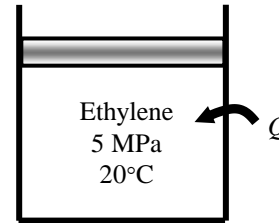

The specific volume change is

$$\begin{aligned} \Delta v &= \frac{R}{P} (Z_2 T_2 - Z_1 T_1) \\ &= \frac{0.2964 \text{ kPa} \cdot \text{m}^3/\text{kg} \cdot \text{K}}{5000 \text{ kPa}} [(0.961)(473 \text{ K}) - (0.56)(293 \text{ K})] \\ &= \mathbf{0.0172 \text{ m}^3/\text{kg}} \end{aligned}$$

3-88 The % error involved in treating CO_2 at a specified state as an ideal gas is to be determined.

Properties The critical pressure, and the critical temperature of CO_2 are, from Table A-1,

$$T_{\text{cr}} = 304.2 \text{ K} \text{ and } P_{\text{cr}} = 7.39 \text{ MPa}$$

Analysis From the compressibility chart (Fig. A-15),

$$\left. \begin{aligned} P_R &= \frac{P}{P_{\text{cr}}} = \frac{7 \text{ MPa}}{7.39 \text{ MPa}} = 0.947 \\ T_R &= \frac{T}{T_{\text{cr}}} = \frac{380 \text{ K}}{304.2 \text{ K}} = 1.25 \end{aligned} \right\} Z = 0.84$$

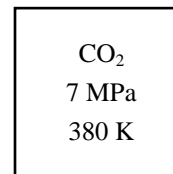

Then the error involved in treating CO_2 as an ideal gas is

$$\text{Error} = \frac{v - v_{\text{ideal}}}{v} = 1 - \frac{1}{Z} = 1 - \frac{1}{0.84} = -0.190 \text{ or } \mathbf{19.0\%}$$

3-89 Water vapor is heated at constant pressure. The final temperature is to be determined using ideal gas equation, the compressibility charts, and the steam tables.

Properties The gas constant, the critical pressure, and the critical temperature of water are, from Table A-1,

$$R = 0.4615 \text{ kPa} \cdot \text{m}^3/\text{kg} \cdot \text{K}, \quad T_{\text{cr}} = 647.1 \text{ K}, \quad P_{\text{cr}} = 22.06 \text{ MPa}$$

Analysis (a) From the ideal gas equation,

$$T_2 = T_1 \frac{\nu_2}{\nu_1} = (350 + 273 \text{ K})(2) = \mathbf{1246 \text{ K}}$$

(b) The pressure of the steam is

$$P_1 = P_2 = P_{\text{sat}@350^\circ\text{C}} = 16,529 \text{ kPa}$$

From the compressibility chart at the initial state (Fig. A-15),

$$\left. \begin{aligned} T_{R1} &= \frac{T_1}{T_{\text{cr}}} = \frac{623 \text{ K}}{647.1 \text{ K}} = 0.963 \\ P_{R1} &= \frac{P_1}{P_{\text{cr}}} = \frac{16.529 \text{ MPa}}{22.06 \text{ MPa}} = 0.749 \end{aligned} \right\} Z_1 = 0.593, \nu_{R1} = 0.75$$

At the final state,

$$\left. \begin{aligned} P_{R2} &= P_{R1} = 0.749 \\ \nu_{R2} &= 2\nu_{R1} = 2(0.75) = 1.50 \end{aligned} \right\} Z_2 = 0.88$$

Thus,

$$T_2 = \frac{P_2 \nu_2}{Z_2 R} = \frac{P_2}{Z_2} \frac{\nu_{R2} T_{\text{cr}}}{P_{\text{cr}}} = \frac{16,529 \text{ kPa}}{0.88} \frac{(1.50)(647.1 \text{ K})}{22,060 \text{ kPa}} = \mathbf{826 \text{ K}}$$

(c) From the superheated steam table,

$$\left. \begin{aligned} T_1 &= 350^\circ\text{C} \\ x_1 &= 1 \end{aligned} \right\} \nu_1 = 0.008806 \text{ m}^3/\text{kg} \quad (\text{Table A-4})$$

$$\left. \begin{aligned} P_2 &= 16,529 \text{ kPa} \\ \nu_2 &= 2\nu_1 = 0.01761 \text{ m}^3/\text{kg} \end{aligned} \right\} T_2 = 477^\circ\text{C} = \mathbf{750 \text{ K}} \quad (\text{from Table A-6 or EES})$$

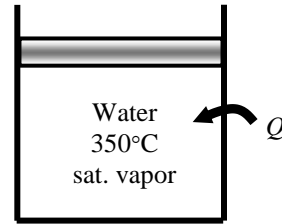

3-90 Methane is heated at constant pressure. The final temperature is to be determined using ideal gas equation and the compressibility charts.

Properties The gas constant, the critical pressure, and the critical temperature of methane are, from Table A-1,

$$R = 0.5182 \text{ kPa} \cdot \text{m}^3/\text{kg} \cdot \text{K}, \quad T_{\text{cr}} = 191.1 \text{ K}, \quad P_{\text{cr}} = 4.64 \text{ MPa}$$

Analysis From the ideal gas equation,

$$T_2 = T_1 \frac{\nu_2}{\nu_1} = (300 \text{ K})(1.8) = \mathbf{540 \text{ K}}$$

From the compressibility chart at the initial state (Fig. A-15),

$$\left. \begin{aligned} T_{R1} &= \frac{T_1}{T_{\text{cr}}} = \frac{300 \text{ K}}{191.1 \text{ K}} = 1.57 \\ P_{R1} &= \frac{P_1}{P_{\text{cr}}} = \frac{10 \text{ MPa}}{4.64 \text{ MPa}} = 2.16 \end{aligned} \right\} Z_1 = 0.86, \nu_{R1} = 0.63$$

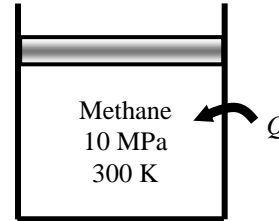

At the final state,

$$\left. \begin{aligned} P_{R2} &= P_{R1} = 2.16 \\ \nu_{R2} &= 1.8\nu_{R1} = 1.8(0.63) = 1.134 \end{aligned} \right\} Z_2 = 0.42 \quad (\text{Fig. A-15})$$

Thus,

$$T_2 = \frac{P_2 \nu_2}{Z_2 R} = \frac{P_2}{Z_2} \frac{\nu_{R2} T_{\text{cr}}}{P_{\text{cr}}} = \frac{10,000 \text{ kPa}}{0.42} \frac{(1.134)(191.1 \text{ K})}{4640 \text{ kPa}} = \mathbf{1112 \text{ K}}$$

Of these two results, the accuracy of the second result is limited by the accuracy with which the charts may be read. Accepting the error associated with reading charts, the second temperature is the more accurate.

3-91 CO₂ gas flows through a pipe. The volume flow rate and the density at the inlet and the volume flow rate at the exit of the pipe are to be determined.

Properties The gas constant, the critical pressure, and the critical temperature of CO₂ are (Table A-1)

$$R = 0.1889 \text{ kPa} \cdot \text{m}^3/\text{kg} \cdot \text{K}, \quad T_{cr} = 304.2 \text{ K}, \quad P_{cr} = 7.39 \text{ MPa}$$

Analysis

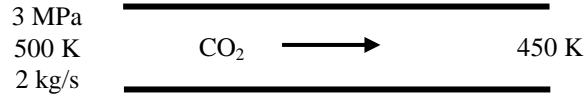

(a) From the ideal gas equation of state,

$$\dot{V}_1 = \frac{\dot{m}RT_1}{P_1} = \frac{(2 \text{ kg/s})(0.1889 \text{ kPa} \cdot \text{m}^3/\text{kg} \cdot \text{K})(500 \text{ K})}{(3000 \text{ kPa})} = \mathbf{0.06297 \text{ m}^3/\text{kg} \text{ (2.1\% error)}}$$

$$\rho_1 = \frac{P_1}{RT_1} = \frac{(3000 \text{ kPa})}{(0.1889 \text{ kPa} \cdot \text{m}^3/\text{kg} \cdot \text{K})(500 \text{ K})} = \mathbf{31.76 \text{ kg/m}^3 \text{ (2.1\% error)}}$$

$$\dot{V}_2 = \frac{\dot{m}RT_2}{P_2} = \frac{(2 \text{ kg/s})(0.1889 \text{ kPa} \cdot \text{m}^3/\text{kg} \cdot \text{K})(450 \text{ K})}{(3000 \text{ kPa})} = \mathbf{0.05667 \text{ m}^3/\text{kg} \text{ (3.6\% error)}}$$

(b) From the compressibility chart (EES function for compressibility factor is used)

$$\left. \begin{aligned} P_R &= \frac{P_1}{P_{cr}} = \frac{3 \text{ MPa}}{7.39 \text{ MPa}} = 0.407 \\ T_{R,1} &= \frac{T_1}{T_{cr}} = \frac{500 \text{ K}}{304.2 \text{ K}} = 1.64 \end{aligned} \right\} Z_1 = 0.9791$$

$$\left. \begin{aligned} P_R &= \frac{P_2}{P_{cr}} = \frac{3 \text{ MPa}}{7.39 \text{ MPa}} = 0.407 \\ T_{R,2} &= \frac{T_2}{T_{cr}} = \frac{450 \text{ K}}{304.2 \text{ K}} = 1.48 \end{aligned} \right\} Z_2 = 0.9656$$

Thus,
$$\dot{V}_1 = \frac{Z_1 \dot{m}RT_1}{P_1} = \frac{(0.9791)(2 \text{ kg/s})(0.1889 \text{ kPa} \cdot \text{m}^3/\text{kg} \cdot \text{K})(500 \text{ K})}{(3000 \text{ kPa})} = \mathbf{0.06165 \text{ m}^3/\text{kg}}$$

$$\rho_1 = \frac{P_1}{Z_1 RT_1} = \frac{(3000 \text{ kPa})}{(0.9791)(0.1889 \text{ kPa} \cdot \text{m}^3/\text{kg} \cdot \text{K})(500 \text{ K})} = \mathbf{32.44 \text{ kg/m}^3}$$

$$\dot{V}_2 = \frac{Z_2 \dot{m}RT_2}{P_2} = \frac{(0.9656)(2 \text{ kg/s})(0.1889 \text{ kPa} \cdot \text{m}^3/\text{kg} \cdot \text{K})(450 \text{ K})}{(3000 \text{ kPa})} = \mathbf{0.05472 \text{ m}^3/\text{kg}}$$

3-92 The pressure of R-134a is to be determined using the ideal gas relation, the compressibility chart, and the R-134a tables.

Properties The gas constant, the critical pressure, and the critical temperature of refrigerant-134a are, from Table A-1,

$$R = 0.08149 \text{ kPa} \cdot \text{m}^3/\text{kg} \cdot \text{K}, \quad T_{\text{cr}} = 374.2 \text{ K}, \quad P_{\text{cr}} = 4.059 \text{ MPa}$$

Analysis The specific volume of the refrigerant is

$$\nu = \frac{V}{m} = \frac{0.016773 \text{ m}^3}{1 \text{ kg}} = 0.016773 \text{ m}^3/\text{kg}$$

(a) From the ideal gas equation of state,

$$P = \frac{RT}{\nu} = \frac{(0.08149 \text{ kPa} \cdot \text{m}^3/\text{kg} \cdot \text{K})(383 \text{ K})}{0.016773 \text{ m}^3/\text{kg}} = \mathbf{1861 \text{ kPa}}$$

R-134a 0.016773 m ³ /kg 110°C
--

(b) From the compressibility chart (Fig. A-15),

$$\left. \begin{aligned} T_R &= \frac{T}{T_{\text{cr}}} = \frac{383 \text{ K}}{374.2 \text{ K}} = 1.023 \\ \nu_R &= \frac{\nu_{\text{actual}}}{RT_{\text{cr}}/P_{\text{cr}}} = \frac{0.016773 \text{ m}^3/\text{kg}}{(0.08149 \text{ kPa} \cdot \text{m}^3/\text{kg} \cdot \text{K})(374.2 \text{ K})/(4059 \text{ kPa})} = 2.24 \end{aligned} \right\} P_R = 0.39$$

Thus,

$$P = P_R P_{\text{cr}} = (0.39)(4059 \text{ kPa}) = \mathbf{1583 \text{ kPa}}$$

(c) From the superheated refrigerant table (Table A-13),

$$\left. \begin{aligned} T &= 110^\circ\text{C} \\ \nu &= 0.016773 \text{ m}^3/\text{kg} \end{aligned} \right\} P = \mathbf{1600 \text{ kPa}}$$

Other Equations of State

3-93C The constant a represents the increase in pressure as a result of intermolecular forces; the constant b represents the volume occupied by the molecules. They are determined from the requirement that the critical isotherm has an inflection point at the critical point.

3-94 The pressure of nitrogen in a tank at a specified state is to be determined using the ideal gas, van der Waals, and Beattie-Bridgeman equations. The error involved in each case is to be determined.

Properties The gas constant, molar mass, critical pressure, and critical temperature of nitrogen are (Table A-1)

$$R = 0.2968 \text{ kPa} \cdot \text{m}^3/\text{kg} \cdot \text{K}, \quad M = 28.013 \text{ kg/kmol}, \quad T_{cr} = 126.2 \text{ K}, \quad P_{cr} = 3.39 \text{ MPa}$$

Analysis The specific volume of nitrogen is

$$v = \frac{V}{m} = \frac{3.27 \text{ m}^3}{100 \text{ kg}} = 0.0327 \text{ m}^3/\text{kg}$$

N_2 $0.0327 \text{ m}^3/\text{kg}$ 175 K

(a) From the ideal gas equation of state,

$$P = \frac{RT}{v} = \frac{(0.2968 \text{ kPa} \cdot \text{m}^3/\text{kg} \cdot \text{K})(175 \text{ K})}{0.0327 \text{ m}^3/\text{kg}} = \mathbf{1588 \text{ kPa (5.5\% error)}}$$

(b) The van der Waals constants for nitrogen are determined from

$$a = \frac{27R^2T_{cr}^2}{64P_{cr}} = \frac{(27)(0.2968 \text{ kPa} \cdot \text{m}^3/\text{kg} \cdot \text{K})^2(126.2 \text{ K})^2}{(64)(3390 \text{ kPa})} = 0.175 \text{ m}^6 \cdot \text{kPa}/\text{kg}^2$$

$$b = \frac{RT_{cr}}{8P_{cr}} = \frac{(0.2968 \text{ kPa} \cdot \text{m}^3/\text{kg} \cdot \text{K})(126.2 \text{ K})}{8 \times 3390 \text{ kPa}} = 0.00138 \text{ m}^3/\text{kg}$$

Then,

$$P = \frac{RT}{v-b} - \frac{a}{v^2} = \frac{0.2968 \times 175}{0.0327 - 0.00138} - \frac{0.175}{(0.0327)^2} = \mathbf{1495 \text{ kPa (0.7\% error)}}$$

(c) The constants in the Beattie-Bridgeman equation are

$$A = A_o \left(1 - \frac{a}{v} \right) = 136.2315 \left(1 - \frac{0.02617}{0.9160} \right) = 132.339$$

$$B = B_o \left(1 - \frac{b}{v} \right) = 0.05046 \left(1 - \frac{-0.00691}{0.9160} \right) = 0.05084$$

$$c = 4.2 \times 10^4 \text{ m}^3 \cdot \text{K}^3/\text{kmol}$$

since $\bar{v} = Mv = (28.013 \text{ kg/kmol})(0.0327 \text{ m}^3/\text{kg}) = 0.9160 \text{ m}^3/\text{kmol}$. Substituting,

$$P = \frac{R_u T}{\bar{v}^2} \left(1 - \frac{c}{\bar{v} T^3} \right) (\bar{v} + B) - \frac{A}{\bar{v}^2}$$

$$= \frac{8.314 \times 175}{(0.9160)^2} \left(1 - \frac{4.2 \times 10^4}{0.9160 \times 175^3} \right) (0.9160 + 0.05084) - \frac{132.339}{(0.9160)^2}$$

$$= \mathbf{1504 \text{ kPa (0.07\% error)}}$$

3-95 Methane is heated in a rigid container. The final pressure of the methane is to be determined using the ideal gas equation and the Benedict-Webb-Rubin equation of state.

Analysis (a) From the ideal gas equation of state,

$$P_2 = P_1 \frac{T_2}{T_1} = (80 \text{ kPa}) \frac{573 \text{ K}}{293 \text{ K}} = \mathbf{156.5 \text{ kPa}}$$

(b) The specific molar volume of the methane is

$$\bar{v}_1 = \bar{v}_2 = \frac{R_u T_1}{P_1} = \frac{(8.314 \text{ kPa} \cdot \text{m}^3/\text{kmol} \cdot \text{K})(293 \text{ K})}{80 \text{ kPa}} = 30.45 \text{ m}^3/\text{kmol}$$

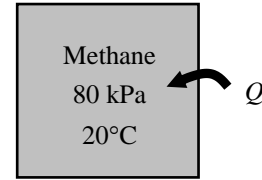

Using the coefficients of Table 3-4 for methane and the given data, the Benedict-Webb-Rubin equation of state for state 2 gives

$$\begin{aligned} P_2 &= \frac{R_u T_2}{\bar{v}_2} + \left(B_0 R_u T_2 - A_0 - \frac{C_0}{T_2} \right) \frac{1}{\bar{v}_2^2} + \frac{b R_u T_2 - a}{\bar{v}_2^3} + \frac{a \alpha}{\bar{v}_2^6} + \frac{c}{\bar{v}_2^3 T_2^2} \left(1 + \frac{\gamma}{\bar{v}_2^2} \right) \exp(-\gamma / \bar{v}_2^2) \\ &= \frac{(8.314)(573)}{30.45} + \left(0.04260 \times 8.314 \times 573 - 187.91 - \frac{2.286 \times 10^6}{573^2} \right) \frac{1}{30.45^2} + \frac{0.003380 \times 8.314 \times 573 - 5.00}{30.45^3} \\ &\quad + \frac{5.00 \times 1.244 \times 10^{-4}}{30.45^6} + \frac{2.578 \times 10^5}{30.45^3 (573)^2} \left(1 + \frac{0.0060}{30.45^2} \right) \exp(-0.0060 / 30.45^2) \\ &= \mathbf{156.5 \text{ kPa}} \end{aligned}$$

3-96E The temperature of R-134a in a tank at a specified state is to be determined using the ideal gas relation, the van der Waals equation, and the refrigerant tables.

Properties The gas constant, critical pressure, and critical temperature of R-134a are (Table A-1E)

$$R = 0.1052 \text{ psia} \cdot \text{ft}^3/\text{lbm} \cdot \text{R}, \quad T_{cr} = 673.6 \text{ R}, \quad P_{cr} = 588.7 \text{ psia}$$

Analysis (a) From the ideal gas equation of state,

$$T = \frac{P\nu}{R} = \frac{(400 \text{ psia})(0.1144 \text{ ft}^3/\text{lbm})}{0.1052 \text{ psia} \cdot \text{ft}^3/\text{lbm} \cdot \text{R}} = \mathbf{435 \text{ R}}$$

(b) The van der Waals constants for the refrigerant are determined from

$$a = \frac{27R^2T_{cr}^2}{64P_{cr}} = \frac{(27)(0.1052 \text{ psia} \cdot \text{ft}^3/\text{lbm} \cdot \text{R})^2 (673.6 \text{ R})^2}{(64)(588.7 \text{ psia})} = 3.596 \text{ ft}^6 \cdot \text{psia}/\text{lbm}^2$$

$$b = \frac{RT_{cr}}{8P_{cr}} = \frac{(0.1052 \text{ psia} \cdot \text{ft}^3/\text{lbm} \cdot \text{R})(673.6 \text{ R})}{8 \times 588.7 \text{ psia}} = 0.01504 \text{ ft}^3/\text{lbm}$$

Then,

$$T = \frac{1}{R} \left(P + \frac{a}{\nu^2} \right) (\nu - b) = \frac{1}{0.1052} \left(400 + \frac{3.591}{(0.3479)^2} \right) (0.1144 - 0.01504) = \mathbf{638 \text{ R}}$$

(c) From the superheated refrigerant table (Table A-13E),

$$\left. \begin{array}{l} P = 400 \text{ psia} \\ \nu = 0.1144 \text{ ft}^3/\text{lbm} \end{array} \right\} T = 100^\circ\text{F} \quad (\mathbf{660 \text{ R}})$$



3-97 The pressure of nitrogen in a tank at a specified state is to be determined using the ideal gas relation and the Beattie-Bridgeman equation. The error involved in each case is to be determined.

Properties The gas constant and molar mass of nitrogen are (Table A-1)

$$R = 0.2968 \text{ kPa} \cdot \text{m}^3/\text{kg} \cdot \text{K} \quad \text{and} \quad M = 28.013 \text{ kg/kmol}$$

Analysis (a) From the ideal gas equation of state,

$$P = \frac{RT}{\nu} = \frac{(0.2968 \text{ kPa} \cdot \text{m}^3/\text{kg} \cdot \text{K})(150 \text{ K})}{0.041884 \text{ m}^3/\text{kg}} = \mathbf{1063 \text{ kPa}} \quad (6.3\% \text{ error})$$

N_2 $0.041884 \text{ m}^3/\text{kg}$ 150 K
--

(b) The constants in the Beattie-Bridgeman equation are

$$A = A_o \left(1 - \frac{a}{\bar{\nu}} \right) = 136.2315 \left(1 - \frac{0.02617}{1.1733} \right) = 133.193$$

$$B = B_o \left(1 - \frac{b}{\bar{\nu}} \right) = 0.05046 \left(1 - \frac{-0.00691}{1.1733} \right) = 0.05076$$

$$c = 4.2 \times 10^4 \text{ m}^3 \cdot \text{K}^3/\text{kmol}$$

since

$$\bar{\nu} = M\nu = (28.013 \text{ kg/kmol})(0.041884 \text{ m}^3/\text{kg}) = 1.1733 \text{ m}^3/\text{kmol}.$$

Substituting,

$$P = \frac{R_u T}{\bar{\nu}^2} \left(1 - \frac{c}{\bar{\nu} T^3} \right) (\bar{\nu} + B) - \frac{A}{\bar{\nu}^2} = \frac{8.314 \times 150}{(1.1733)^2} \left(1 - \frac{4.2 \times 10^4}{1.1733 \times 150^3} \right) (1.1733 + 0.05076) - \frac{133.193}{(1.1733)^2}$$

$$= \mathbf{1000.4 \text{ kPa}} \quad (\text{negligible error})$$



3-98 Problem 3-97 is reconsidered. Using EES (or other) software, the pressure results of the ideal gas and Beattie-Bridgeman equations with nitrogen data supplied by EES are to be compared. The temperature is to be plotted versus specific volume for a pressure of 1000 kPa with respect to the saturated liquid and saturated vapor lines of nitrogen over the range of $110 \text{ K} < T < 150 \text{ K}$.

Analysis The problem is solved using EES, and the solution is given below.

```
Function BeattBridg(T,v,M,R_u)
v_bar=v*M "Conversion from m^3/kg to m^3/kmol"
"The constants for the Beattie-Bridgeman equation of state are found in text"
Ao=136.2315; aa=0.02617; Bo=0.05046; bb=-0.00691; cc=4.20*1E4
B=Bo*(1-bb/v_bar)
A=Ao*(1-aa/v_bar)
"The Beattie-Bridgeman equation of state is"
BeattBridg:=R_u*T/(v_bar**2)*(1-cc/(v_bar*T**3))*(v_bar+B)-A/v_bar**2
End

T=150 [K]
v=0.041884 [m^3/kg]
P_exper=1000 [kPa]
T_table=T; T_BB=T;T_idealgas=T
P_table=PRESSURE(Nitrogen,T=T_table,v=v) "EES data for nitrogen as a real gas"
{T_table=temperature(Nitrogen, P=P_table,v=v)}
M=MOLARMASS(Nitrogen)
R_u=8.314 [kJ/kmol-K] "Universal gas constant"
R=R_u/M "Particular gas constant"
P_idealgas=R*T_idealgas/v "Ideal gas equation"
P_BB=BeattBridg(T_BB,v,M,R_u) "Beattie-Bridgeman equation of state Function"
```

P_{BB} [kPa]	P_{table} [kPa]	$P_{idealgas}$ [kPa]	v [m ³ /kg]	T_{BB} [K]	$T_{ideal\ gas}$ [K]	T_{table} [K]
1000	1000	1000	0.01	91.23	33.69	103.8
1000	1000	1000	0.02	95.52	67.39	103.8
1000	1000	1000	0.025	105	84.23	106.1
1000	1000	1000	0.03	116.8	101.1	117.2
1000	1000	1000	0.035	130.1	117.9	130.1
1000	1000	1000	0.04	144.4	134.8	144.3
1000	1000	1000	0.05	174.6	168.5	174.5

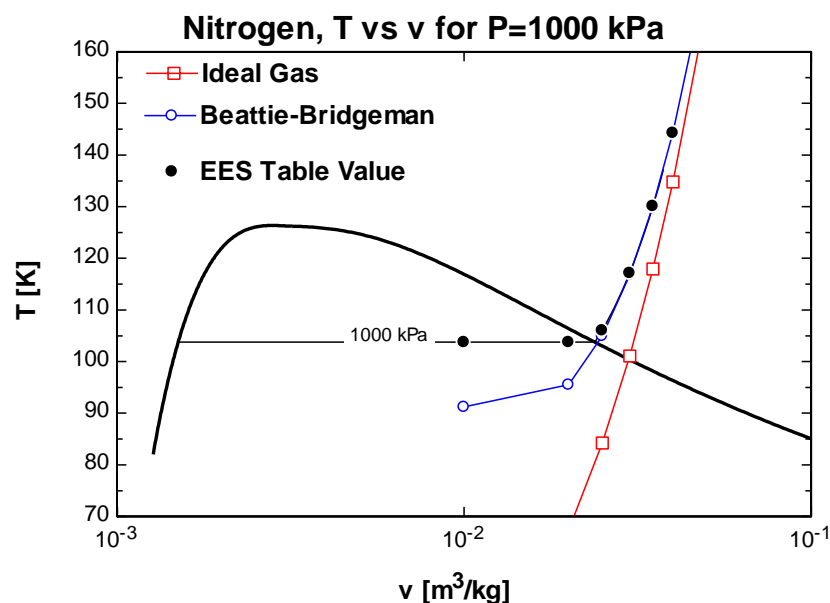

3-99 Carbon dioxide is compressed in a piston-cylinder device in a polytropic process. The final temperature is to be determined using the ideal gas and van der Waals equations.

Properties The gas constant, molar mass, critical pressure, and critical temperature of carbon dioxide are (Table A-1)

$$R = 0.1889 \text{ kPa} \cdot \text{m}^3/\text{kg} \cdot \text{K}, \quad M = 44.01 \text{ kg/kmol}, \quad T_{\text{cr}} = 304.2 \text{ K}, \quad P_{\text{cr}} = 7.39 \text{ MPa}$$

Analysis (a) The specific volume at the initial state is

$$\nu_1 = \frac{RT_1}{P_1} = \frac{(0.1889 \text{ kPa} \cdot \text{m}^3/\text{kg} \cdot \text{K})(473 \text{ K})}{1000 \text{ kPa}} = 0.08935 \text{ m}^3/\text{kg}$$

According to process specification,

$$\nu_2 = \nu_1 \left(\frac{P_1}{P_2} \right)^{1/n} = (0.08935 \text{ m}^3/\text{kg}) \left(\frac{1000 \text{ kPa}}{3000 \text{ kPa}} \right)^{1/1.2} = 0.03577 \text{ m}^3/\text{kg}$$

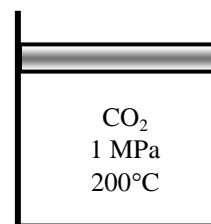

The final temperature is then

$$T_2 = \frac{P_2 \nu_2}{R} = \frac{(3000 \text{ kPa})(0.03577 \text{ m}^3/\text{kg})}{0.1889 \text{ kPa} \cdot \text{m}^3/\text{kg} \cdot \text{K}} = \mathbf{568 \text{ K}}$$

(b) The van der Waals constants for carbon dioxide are determined from

$$a = \frac{27R^2 T_{\text{cr}}^2}{64P_{\text{cr}}} = \frac{(27)(0.1889 \text{ kPa} \cdot \text{m}^3/\text{kg} \cdot \text{K})^2 (304.2 \text{ K})^2}{(64)(7390 \text{ kPa})} = 0.1885 \text{ m}^6 \cdot \text{kPa}/\text{kg}^2$$

$$b = \frac{RT_{\text{cr}}}{8P_{\text{cr}}} = \frac{(0.1889 \text{ kPa} \cdot \text{m}^3/\text{kg} \cdot \text{K})(304.2 \text{ K})}{8 \times 7390 \text{ kPa}} = 0.0009720 \text{ m}^3/\text{kg}$$

Applying the van der Waals equation to the initial state,

$$\left(P + \frac{a}{\nu^2} \right) (\nu - b) = RT$$

$$\left(1000 + \frac{0.1885}{\nu^2} \right) (\nu - 0.0009720) = (0.1889)(473)$$

Solving this equation by trial-error or by EES gives

$$\nu_1 = 0.08821 \text{ m}^3/\text{kg}$$

According to process specification,

$$\nu_2 = \nu_1 \left(\frac{P_1}{P_2} \right)^{1/n} = (0.08821 \text{ m}^3/\text{kg}) \left(\frac{1000 \text{ kPa}}{3000 \text{ kPa}} \right)^{1/1.2} = 0.03531 \text{ m}^3/\text{kg}$$

Applying the van der Waals equation to the final state,

$$\left(P + \frac{a}{\nu^2} \right) (\nu - b) = RT$$

$$\left(3000 + \frac{0.1885}{0.03531^2} \right) (0.03531 - 0.0009720) = (0.1889)T$$

Solving for the final temperature gives

$$T_2 = \mathbf{573 \text{ K}}$$

3-100 The temperature of steam in a tank at a specified state is to be determined using the ideal gas relation, van der Waals equation, and the steam tables.

Properties The gas constant, critical pressure, and critical temperature of steam are (Table A-1)

$$R = 0.4615 \text{ kPa} \cdot \text{m}^3/\text{kg} \cdot \text{K}, \quad T_{cr} = 647.1 \text{ K}, \quad P_{cr} = 22.06 \text{ MPa}$$

Analysis The specific volume of steam is

$$\nu = \frac{V}{m} = \frac{1 \text{ m}^3}{2.841 \text{ kg}} = 0.3520 \text{ m}^3/\text{kg}$$

H ₂ O
1 m ³
2.841 kg
0.6 MPa

(a) From the ideal gas equation of state,

$$T = \frac{P\nu}{R} = \frac{(600 \text{ kPa})(0.352 \text{ m}^3/\text{kg})}{0.4615 \text{ kPa} \cdot \text{m}^3/\text{kg} \cdot \text{K}} = \mathbf{457.6 \text{ K}}$$

(b) The van der Waals constants for steam are determined from

$$a = \frac{27R^2T_{cr}^2}{64P_{cr}} = \frac{(27)(0.4615 \text{ kPa} \cdot \text{m}^3/\text{kg} \cdot \text{K})^2 (647.1 \text{ K})^2}{(64)(22,060 \text{ kPa})} = 1.705 \text{ m}^6 \cdot \text{kPa}/\text{kg}^2$$

$$b = \frac{RT_{cr}}{8P_{cr}} = \frac{(0.4615 \text{ kPa} \cdot \text{m}^3/\text{kg} \cdot \text{K})(647.1 \text{ K})}{8 \times 22,060 \text{ kPa}} = 0.00169 \text{ m}^3/\text{kg}$$

Then,

$$T = \frac{1}{R} \left(P + \frac{a}{\nu^2} \right) (\nu - b) = \frac{1}{0.4615} \left(600 + \frac{1.705}{(0.3520)^2} \right) (0.352 - 0.00169) = \mathbf{465.9 \text{ K}}$$

(c) From the superheated steam table (Tables A-6),

$$\left. \begin{array}{l} P = 0.6 \text{ MPa} \\ \nu = 0.3520 \text{ m}^3/\text{kg} \end{array} \right\} T = \mathbf{200^\circ\text{C}} \quad (= 473 \text{ K})$$



3-101 Problem 3-100 is reconsidered. The problem is to be solved using EES (or other) software. The temperature of water is to be compared for the three cases at constant specific volume over the pressure range of 0.1 MPa to 1 MPa in 0.1 MPa increments. The %error involved in the ideal gas approximation is to be plotted against pressure.

Analysis The problem is solved using EES, and the solution is given below.

```
Function vanderWaals(T,v,M,R_u,T_cr,P_cr)
v_bar=v*M "Conversion from m^3/kg to m^3/kmol"
```

"The constants for the van der Waals equation of state are given by equation 3-24"

```
a=27*R_u^2*T_cr^2/(64*P_cr)
```

```
b=R_u*T_cr/(8*P_cr)
```

"The van der Waals equation of state gives the pressure as"

```
vanderWaals:=R_u*T/(v_bar-b)-a/v_bar**2
```

End

```
m=2.841[kg]
```

```
Vol=1 [m^3]
```

```
{P=6*convert(MPa,kPa)}
```

```
T_cr=T_CRIT(Steam_iapws)
```

```
P_cr=P_CRIT(Steam_iapws)
```

```
v=Vol/m
```

```
P_table=P; P_vdW=P;P_idealgas=P
```

```
T_table=temperature(Steam_iapws,P=P_table,v=v) "EES data for steam as a real gas"
```

```
{P_table=pressure(Steam_iapws, T=T_table,v=v)}
```

```
{T_sat=temperature(Steam_iapws,P=P_table,v=v)}
```

```
MM=MOLARMASS(water)
```

```
R_u=8.314 [kJ/kmol-K] "Universal gas constant"
```

```
R=R_u/MM "Particular gas constant"
```

```
P_idealgas=R*T_idealgas/v "Ideal gas equation"
```

"The value of P_vdW is found from van der Waals equation of state Function"

```
P_vdW=vanderWaals(T_vdW,v,MM,R_u,T_cr,P_cr)
```

```
Error_idealgas=Abs(T_table-T_idealgas)/T_table*Convert(, %)
```

```
Error_vdW=Abs(T_table-T_vdW)/T_table*Convert(, %)
```

P [kPa]	T _{ideal gas} [K]	T _{table} [K]	T _{vdW} [K]	Error _{ideal gas} [K]
100	76.27	372.8	86.35	79.54
200	152.5	393.4	162.3	61.22
300	228.8	406.7	238.2	43.74
400	305.1	416.8	314.1	26.8
500	381.4	425	390	10.27
600	457.6	473	465.9	3.249
700	533.9	545.3	541.8	2.087
800	610.2	619.1	617.7	1.442
900	686.4	693.7	693.6	1.041
1000	762.7	768.6	769.5	0.7725

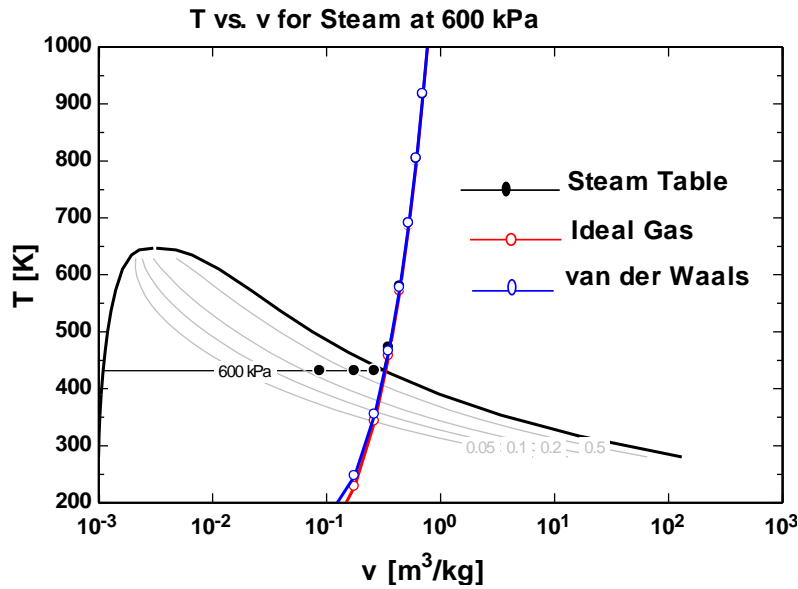
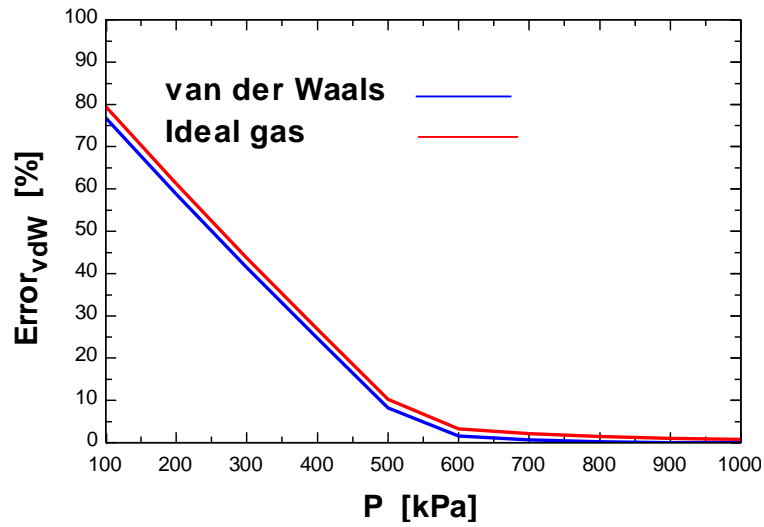

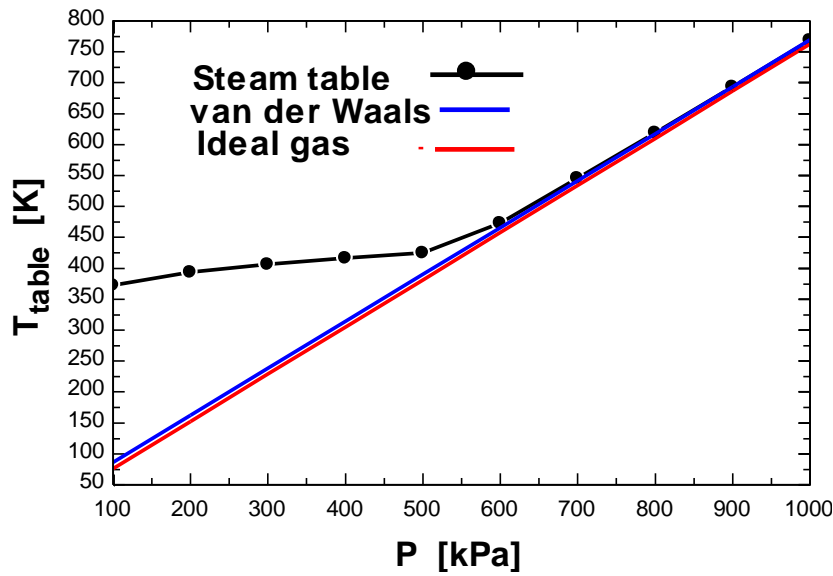
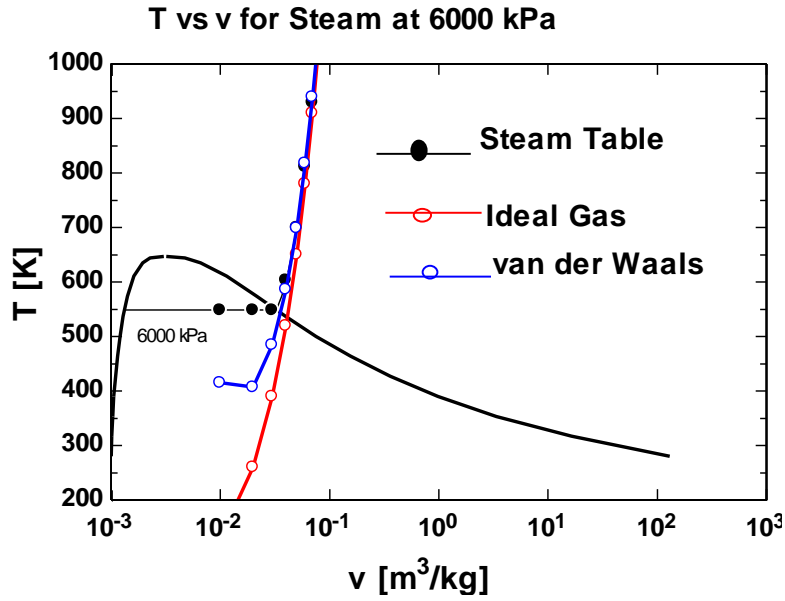

Special Topic: Vapor Pressure and Phase Equilibrium

3-102 The vapor pressure in the air at the beach when the air temperature is 30°C is claimed to be 5.2 kPa. The validity of this claim is to be evaluated.

Properties The saturation pressure of water at 30°C is 4.247 kPa (Table A-4).

Analysis The maximum vapor pressure in the air is the saturation pressure of water at the given temperature, which is

$$P_{v, \max} = P_{\text{sat}@T_{\text{air}}} = P_{\text{sat}@30^\circ\text{C}} = \mathbf{4.247 \text{ kPa}}$$

which is less than the claimed value of 5.2 kPa. Therefore, the claim is **false**.



3-103 A glass of water is left in a room. The vapor pressures at the free surface of the water and in the room far from the glass are to be determined.

Assumptions The water in the glass is at a uniform temperature.

Properties The saturation pressure of water is 2.339 kPa at 20°C, and 1.706 kPa at 15°C (Table A-4).

Analysis The vapor pressure at the water surface is the saturation pressure of water at the water temperature,

$$P_{v, \text{ water surface}} = P_{\text{sat}@T_{\text{water}}} = P_{\text{sat}@15^\circ\text{C}} = \mathbf{1.706 \text{ kPa}}$$

Noting that the air in the room is not saturated, the vapor pressure in the room far from the glass is

$$P_{v, \text{ air}} = \phi P_{\text{sat}@T_{\text{air}}} = \phi P_{\text{sat}@20^\circ\text{C}} = (0.4)(2.339 \text{ kPa}) = \mathbf{0.936 \text{ kPa}}$$

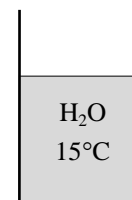

3-104 The temperature and relative humidity of air over a swimming pool are given. The water temperature of the swimming pool when phase equilibrium conditions are established is to be determined.

Assumptions The temperature and relative humidity of air over the pool remain constant.

Properties The saturation pressure of water at 25°C is 3.17 kPa (Table A-4).

Analysis The vapor pressure of air over the swimming pool is

$$P_{v, \text{ air}} = \phi P_{\text{sat}@T_{\text{air}}} = \phi P_{\text{sat}@25^\circ\text{C}} = (0.6)(3.170 \text{ kPa}) = 1.902 \text{ kPa}$$

Phase equilibrium will be established when the vapor pressure at the water surface equals the vapor pressure of air far from the surface. Therefore,

$$P_{v, \text{ water surface}} = P_{v, \text{ air}} = 1.902 \text{ kPa}$$

and $T_{\text{water}} = T_{\text{sat}@P_v} = T_{\text{sat}@1.902 \text{ kPa}} = \mathbf{16.7^\circ\text{C}}$

Discussion Note that the water temperature drops to 16.7°C in an environment at 25°C when phase equilibrium is established.

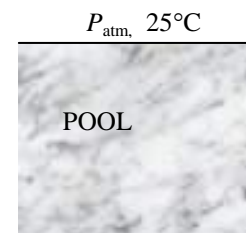

3-105 A person buys a supposedly cold drink in a hot and humid summer day, yet no condensation occurs on the drink. The claim that the temperature of the drink is below 10°C is to be evaluated.

Properties The saturation pressure of water at 35°C is 5.629 kPa (Table A-4).

Analysis The vapor pressure of air is

$$P_{v, \text{air}} = \phi P_{\text{sat}} @ T_{\text{air}} = \phi P_{\text{sat}} @ 35^{\circ}\text{C} = (0.7)(5.629 \text{ kPa}) = 3.940 \text{ kPa}$$

The saturation temperature corresponding to this pressure (called the dew-point temperature) is

$$T_{\text{sat}} = T_{\text{sat}} @ P_v = T_{\text{sat}} @ 3.940 \text{ kPa} = \mathbf{28.7^{\circ}\text{C}}$$

That is, the vapor in the air will condense at temperatures below 28.7°C. Noting that no condensation is observed on the can, the claim that the drink is at 10°C is **false**.

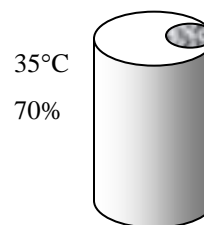

3-106 Two rooms are identical except that they are maintained at different temperatures and relative humidities. The room that contains more moisture is to be determined.

Properties The saturation pressure of water is 2.339 kPa at 20°C, and 3.17 kPa at 25°C (Table A-4).

Analysis The vapor pressures in the two rooms are

$$\text{Room 1:} \quad P_{v1} = \phi_1 P_{\text{sat}} @ T_1 = \phi_1 P_{\text{sat}} @ 25^{\circ}\text{C} = (0.4)(3.17 \text{ kPa}) = \mathbf{1.27 \text{ kPa}}$$

$$\text{Room 2:} \quad P_{v2} = \phi_2 P_{\text{sat}} @ T_2 = \phi_2 P_{\text{sat}} @ 20^{\circ}\text{C} = (0.55)(2.339 \text{ kPa}) = \mathbf{1.29 \text{ kPa}}$$

Therefore, room 1 at 30°C and 40% relative humidity contains more moisture.

3-107E A thermos bottle half-filled with water is left open to air in a room at a specified temperature and pressure. The temperature of water when phase equilibrium is established is to be determined.

Assumptions The temperature and relative humidity of air over the bottle remain constant.

Properties The saturation pressure of water at 60°F is 0.2564 psia (Table A-4E).

Analysis The vapor pressure of air in the room is

$$P_{v, \text{air}} = \phi P_{\text{sat}} @ T_{\text{air}} = \phi P_{\text{sat}} @ 70^{\circ}\text{F} = (0.35)(0.2564 \text{ psia}) = 0.08973 \text{ psia}$$

Phase equilibrium will be established when the vapor pressure at the water surface equals the vapor pressure of air far from the surface. Therefore,

$$P_{v, \text{water surface}} = P_{v, \text{air}} = 0.08973 \text{ psia}$$

and

$$T_{\text{water}} = T_{\text{sat}} @ P_v = T_{\text{sat}} @ 0.08973 \text{ psia} = \mathbf{32.3^{\circ}\text{F}}$$

Discussion Note that the water temperature drops to 32.3°F in an environment at 60°F when phase equilibrium is established.

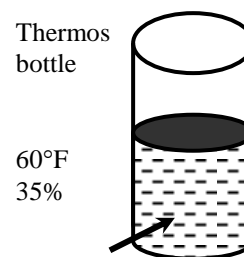

Review Problems

3-108E Water in a pressure cooker boils at 260°F. The absolute pressure in the pressure cooker is to be determined.

Analysis The absolute pressure in the pressure cooker is the saturation pressure that corresponds to the boiling temperature,

$$P = P_{\text{sat}@260^\circ\text{F}} = \mathbf{35.45 \text{ psia}}$$

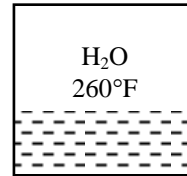

3-109 Carbon dioxide flows through a pipe at a given state. The volume and mass flow rates and the density of CO₂ at the given state and the volume flow rate at the exit of the pipe are to be determined.

Analysis

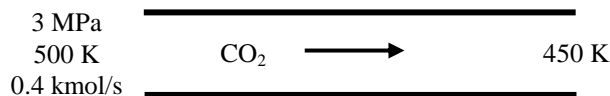

(a) The volume and mass flow rates may be determined from ideal gas relation as

$$\dot{V}_1 = \frac{\dot{N}R_u T_1}{P} = \frac{(0.4 \text{ kmol/s})(8.314 \text{ kPa}\cdot\text{m}^3/\text{kmol}\cdot\text{K})(500 \text{ K})}{3000 \text{ kPa}} = \mathbf{0.5543 \text{ m}^3/\text{s}}$$

$$\dot{m}_1 = \frac{P_1 \dot{V}_1}{RT_1} = \frac{(3000 \text{ kPa})(0.5543 \text{ m}^3/\text{s})}{(0.1889 \text{ kPa}\cdot\text{m}^3/\text{kg}\cdot\text{K})(500 \text{ K})} = \mathbf{17.60 \text{ kg/s}}$$

The density is

$$\rho_1 = \frac{\dot{m}_1}{\dot{V}_1} = \frac{(17.60 \text{ kg/s})}{(0.5543 \text{ m}^3/\text{s})} = \mathbf{31.76 \text{ kg/m}^3}$$

(b) The volume flow rate at the exit is

$$\dot{V}_2 = \frac{\dot{N}R_u T_2}{P} = \frac{(0.4 \text{ kmol/s})(8.314 \text{ kPa}\cdot\text{m}^3/\text{kmol}\cdot\text{K})(450 \text{ K})}{3000 \text{ kPa}} = \mathbf{0.4988 \text{ m}^3/\text{s}}$$

3-110 A tank contains argon at a specified state. Heat is transferred from argon until it reaches a specified temperature. The final gage pressure of the argon is to be determined.

Assumptions 1 Argon is an ideal gas.

Properties The local atmospheric pressure is given to be 100 kPa.

Analysis Noting that the specific volume of argon in the tank remains constant, from ideal gas relation, we have

$$P_2 = P_1 \frac{T_2}{T_1} = (200 + 100 \text{ kPa}) \frac{(300 + 273) \text{ K}}{(600 + 273) \text{ K}} = 196.9 \text{ kPa}$$

Then the gage pressure becomes

$$P_{\text{gage},2} = P_2 - P_{\text{atm}} = 196.9 - 100 = \mathbf{96.9 \text{ kPa}}$$

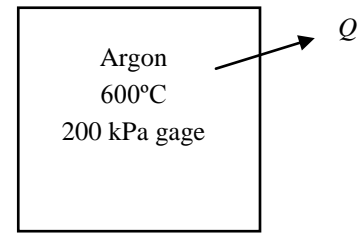

3-111 The cylinder conditions before the heat addition process is specified. The pressure after the heat addition process is to be determined.

Assumptions 1 The contents of cylinder are approximated by the air properties.

2 Air is an ideal gas.

Analysis The final pressure may be determined from the ideal gas relation

$$P_2 = \frac{T_2}{T_1} P_1 = \left(\frac{1750 + 273 \text{ K}}{450 + 273 \text{ K}} \right) (1200 \text{ kPa}) = \mathbf{3358 \text{ kPa}}$$

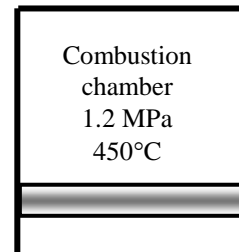

3-112 A rigid container that is filled with R-134a is heated. The initial pressure and the final temperature are to be determined.

Analysis The initial specific volume is $0.090 \text{ m}^3/\text{kg}$. Using this with the initial temperature reveals that the initial state is a mixture. The initial pressure is then the saturation pressure,

$$\left. \begin{array}{l} T_1 = -40^\circ\text{C} \\ \nu_1 = 0.090 \text{ m}^3/\text{kg} \end{array} \right\} P_1 = P_{\text{sat @ } -40^\circ\text{C}} = \mathbf{51.25 \text{ kPa}} \text{ (Table A-11)}$$

This is a constant volume cooling process ($\nu = \mathbf{V}/m = \text{constant}$). The final state is superheated vapor and the final temperature is then

$$\left. \begin{array}{l} P_2 = 280 \text{ kPa} \\ \nu_2 = \nu_1 = 0.090 \text{ m}^3/\text{kg} \end{array} \right\} T_2 = \mathbf{50^\circ\text{C}} \text{ (Table A-13)}$$

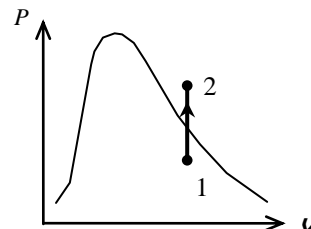
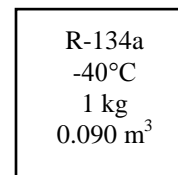

3-113 The refrigerant in a rigid tank is allowed to cool. The pressure at which the refrigerant starts condensing is to be determined, and the process is to be shown on a P - v diagram.

Analysis This is a constant volume process ($v = V/m = \text{constant}$), and the specific volume is determined to be

$$v = \frac{V}{m} = \frac{0.117 \text{ m}^3}{1 \text{ kg}} = 0.117 \text{ m}^3/\text{kg}$$

When the refrigerant starts condensing, the tank will contain saturated vapor only. Thus,

$$v_2 = v_g = 0.117 \text{ m}^3/\text{kg}$$

The pressure at this point is the pressure that corresponds to this v_g value,

$$P_2 = P_{\text{sat}@v_g=0.117\text{m}^3/\text{kg}} = \mathbf{170\text{kPa}}$$

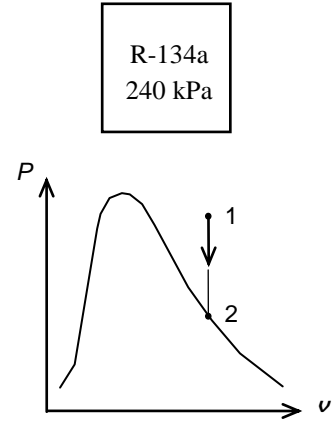

3-114E A piston-cylinder device that is filled with water is cooled. The final pressure and volume of the water are to be determined.

Analysis The initial specific volume is

$$v_1 = \frac{V_1}{m} = \frac{2.649 \text{ ft}^3}{1 \text{ lbm}} = 2.649 \text{ ft}^3/\text{lbm}$$

This is a constant-pressure process. The initial state is determined to be superheated vapor and thus the pressure is determined to be

$$\left. \begin{array}{l} T_1 = 400^\circ\text{F} \\ v_1 = 2.649 \text{ ft}^3/\text{lbm} \end{array} \right\} P_1 = P_2 = \mathbf{180\text{psia}} \text{ (Table A - 6E)}$$

The saturation temperature at 180 psia is 373.1°F . Since the final temperature is less than this temperature, the final state is compressed liquid. Using the incompressible liquid approximation,

$$v_2 = v_f @ 100^\circ\text{F} = 0.01613 \text{ ft}^3/\text{lbm} \text{ (Table A - 4E)}$$

The final volume is then

$$V_2 = m v_2 = (1 \text{ lbm})(0.01613 \text{ ft}^3/\text{lbm}) = \mathbf{0.01613\text{ft}^3}$$

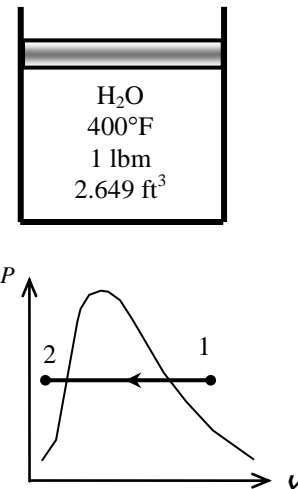

3-115 Ethane is heated at constant pressure. The final temperature is to be determined using ideal gas equation and the compressibility charts.

Properties The gas constant, the critical pressure, and the critical temperature of ethane are, from Table A-1,

$$R = 0.2765 \text{ kPa} \cdot \text{m}^3/\text{kg} \cdot \text{K}, \quad T_{\text{cr}} = 305.5 \text{ K}, \quad P_{\text{cr}} = 4.48 \text{ MPa}$$

Analysis From the ideal gas equation,

$$T_2 = T_1 \frac{\nu_2}{\nu_1} = (373 \text{ K})(1.6) = \mathbf{596.8 \text{ K}}$$

From the compressibility chart at the initial state (Fig. A-15),

$$\left. \begin{aligned} T_{R1} &= \frac{T_1}{T_{\text{cr}}} = \frac{373 \text{ K}}{305.5 \text{ K}} = 1.221 \\ P_{R1} &= \frac{P_1}{P_{\text{cr}}} = \frac{10 \text{ MPa}}{4.48 \text{ MPa}} = 2.232 \end{aligned} \right\} Z_1 = 0.61, \nu_{R1} = 0.35$$

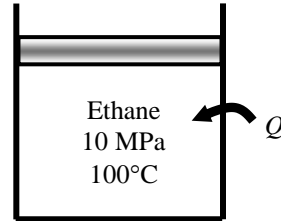

At the final state,

$$\left. \begin{aligned} P_{R2} &= P_{R1} = 2.232 \\ \nu_{R2} &= 1.6\nu_{R1} = 1.6(0.35) = 0.56 \end{aligned} \right\} Z_2 = 0.83$$

Thus,

$$T_2 = \frac{P_2 \nu_2}{Z_2 R} = \frac{P_2}{Z_2} \frac{\nu_{R2} T_{\text{cr}}}{P_{\text{cr}}} = \frac{10,000 \text{ kPa}}{0.83} \frac{(0.56)(305.5 \text{ K})}{4480 \text{ kPa}} = \mathbf{460 \text{ K}}$$

Of these two results, the accuracy of the second result is limited by the accuracy with which the charts may be read. Accepting the error associated with reading charts, the second temperature is the more accurate.

3-116 A large tank contains nitrogen at a specified temperature and pressure. Now some nitrogen is allowed to escape, and the temperature and pressure of nitrogen drop to new values. The amount of nitrogen that has escaped is to be determined.

Properties The gas constant for nitrogen is $0.2968 \text{ kPa} \cdot \text{m}^3/\text{kg} \cdot \text{K}$ (Table A-1).

Analysis Treating N_2 as an ideal gas, the initial and the final masses in the tank are determined to be

$$m_1 = \frac{P_1 \mathcal{V}}{RT_1} = \frac{(600 \text{ kPa})(13 \text{ m}^3)}{(0.2968 \text{ kPa} \cdot \text{m}^3/\text{kg} \cdot \text{K})(290 \text{ K})} = 90.62 \text{ kg}$$

$$m_2 = \frac{P_2 \mathcal{V}}{RT_2} = \frac{(400 \text{ kPa})(13 \text{ m}^3)}{(0.2968 \text{ kPa} \cdot \text{m}^3/\text{kg} \cdot \text{K})(278 \text{ K})} = 60.84 \text{ kg}$$

Thus the amount of N_2 that escaped is

$$\Delta m = m_1 - m_2 = 90.62 - 60.84 = \mathbf{29.8 \text{ kg}}$$

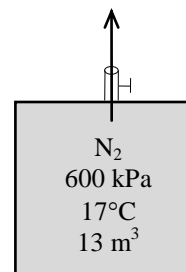

3-117 Superheated refrigerant-134a is cooled at constant pressure until it exists as a compressed liquid. The changes in total volume and internal energy are to be determined, and the process is to be shown on a T - v diagram.

Analysis The refrigerant is a superheated vapor at the initial state and a compressed liquid at the final state. From Tables A-13 and A-11,

$$\left. \begin{aligned} P_1 &= 1.2 \text{ MPa} \\ T_1 &= 70^\circ\text{C} \end{aligned} \right\} \begin{aligned} u_1 &= 277.23 \text{ kJ/kg} \\ v_1 &= 0.019502 \text{ m}^3/\text{kg} \end{aligned}$$

$$\left. \begin{aligned} P_2 &= 1.2 \text{ MPa} \\ T_2 &= 20^\circ\text{C} \end{aligned} \right\} \begin{aligned} u_2 &\cong u_{f@20^\circ\text{C}} = 78.85 \text{ kJ/kg} \\ v_2 &\cong v_{f@20^\circ\text{C}} = 0.0008160 \text{ m}^3/\text{kg} \end{aligned}$$

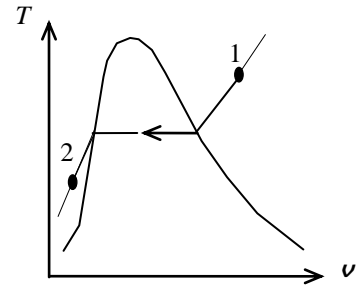
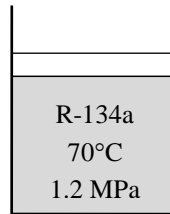

Thus,

(b) $\Delta V = m(v_2 - v_1) = (10 \text{ kg})(0.0008160 - 0.019502) \text{ m}^3/\text{kg} = \mathbf{-0.187 \text{ m}^3}$

(c) $\Delta U = m(u_2 - u_1) = (10 \text{ kg})(78.85 - 277.23) \text{ kJ/kg} = \mathbf{-1984 \text{ kJ}}$

3-118 The rigid tank contains saturated liquid-vapor mixture of water. The mixture is heated until it exists in a single phase. For a given tank volume, it is to be determined if the final phase is a liquid or a vapor.

Analysis This is a constant volume process ($v = V/m = \text{constant}$), and thus the final specific volume will be equal to the initial specific volume,

$$v_2 = v_1$$

The critical specific volume of water is $0.003106 \text{ m}^3/\text{kg}$. Thus if the final specific volume is smaller than this value, the water will exist as a liquid, otherwise as a vapor.

$$V = 4L \longrightarrow v = \frac{V}{m} = \frac{0.004 \text{ m}^3}{2 \text{ kg}} = 0.002 \text{ m}^3/\text{kg} < v_{\text{cr}} \quad \text{Thus, liquid.}$$

$$V = 400L \longrightarrow v = \frac{V}{m} = \frac{0.4 \text{ m}^3}{2 \text{ kg}} = 0.2 \text{ m}^3/\text{kg} > v_{\text{cr}} \quad \text{Thus, vapor.}$$

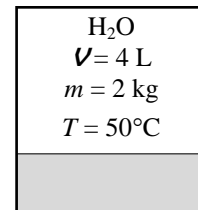

3-119 The pressure in an automobile tire increases during a trip while its volume remains constant. The percent increase in the absolute temperature of the air in the tire is to be determined.

Assumptions 1 The volume of the tire remains constant. **2** Air is an ideal gas.

Properties The local atmospheric pressure is 90 kPa.

Analysis The absolute pressures in the tire before and after the trip are

$$P_1 = P_{\text{gage},1} + P_{\text{atm}} = 200 + 90 = 290 \text{ kPa}$$

$$P_2 = P_{\text{gage},2} + P_{\text{atm}} = 220 + 90 = 310 \text{ kPa}$$

Noting that air is an ideal gas and the volume is constant, the ratio of absolute temperatures after and before the trip are

$$\frac{P_1 V_1}{T_1} = \frac{P_2 V_2}{T_2} \rightarrow \frac{T_2}{T_1} = \frac{P_2}{P_1} = \frac{310 \text{ kPa}}{290 \text{ kPa}} = 1.069$$

Therefore, the absolute temperature of air in the tire will increase by **6.9%** during this trip.

Tire
200 kPa
0.035 m³

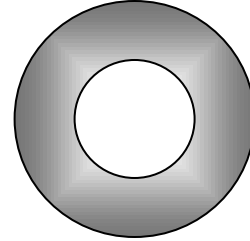

3-120 A piston-cylinder device contains steam at a specified state. Steam is cooled at constant pressure. The volume change is to be determined using compressibility factor.

Properties The gas constant, the critical pressure, and the critical temperature of steam are

$$R = 0.4615 \text{ kPa} \cdot \text{m}^3/\text{kg} \cdot \text{K}, \quad T_{cr} = 647.1 \text{ K}, \quad P_{cr} = 22.06 \text{ MPa}$$

Analysis The exact solution is given by the following:

$$\left. \begin{array}{l} P = 200 \text{ kPa} \\ T_1 = 300^\circ\text{C} \end{array} \right\} \nu_1 = 1.31623 \text{ m}^3/\text{kg} \quad (\text{Table A-6})$$

$$\left. \begin{array}{l} P = 200 \text{ kPa} \\ T_2 = 150^\circ\text{C} \end{array} \right\} \nu_2 = 0.95986 \text{ m}^3/\text{kg}$$

$$\Delta V_{\text{exact}} = m(\nu_1 - \nu_2) = (0.2 \text{ kg})(1.31623 - 0.95986) \text{ m}^3/\text{kg} = \mathbf{0.07128 \text{ m}^3}$$

Using compressibility chart (EES function for compressibility factor is used)

$$\left. \begin{array}{l} P_R = \frac{P_1}{P_{cr}} = \frac{0.2 \text{ MPa}}{22.06 \text{ MPa}} = 0.0091 \\ T_{R,1} = \frac{T_1}{T_{cr}} = \frac{300 + 273 \text{ K}}{647.1 \text{ K}} = 0.886 \end{array} \right\} Z_1 = 0.9956$$

$$\left. \begin{array}{l} P_R = \frac{P_2}{P_{cr}} = \frac{0.2 \text{ MPa}}{22.06 \text{ MPa}} = 0.0091 \\ T_{R,2} = \frac{T_2}{T_{cr}} = \frac{150 + 273 \text{ K}}{647.1 \text{ K}} = 0.65 \end{array} \right\} Z_2 = 0.9897$$

$$\nu_1 = \frac{Z_1 m R T_1}{P_1} = \frac{(0.9956)(0.2 \text{ kg})(0.4615 \text{ kPa} \cdot \text{m}^3/\text{kg} \cdot \text{K})(300 + 273 \text{ K})}{(200 \text{ kPa})} = 0.2633 \text{ m}^3$$

$$\nu_2 = \frac{Z_2 m R T_2}{P_2} = \frac{(0.9897)(0.2 \text{ kg})(0.4615 \text{ kPa} \cdot \text{m}^3/\text{kg} \cdot \text{K})(150 + 273 \text{ K})}{(200 \text{ kPa})} = 0.1932 \text{ m}^3$$

$$\Delta V_{\text{chart}} = \nu_1 - \nu_2 = 0.2633 - 0.1932 = \mathbf{0.07006 \text{ m}^3}, \quad \text{Error} : \mathbf{1.7\%}$$

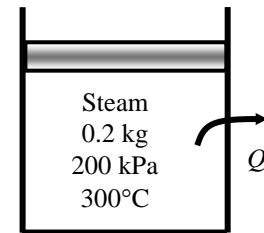

3-121 The temperature of steam in a tank at a specified state is to be determined using the ideal gas relation, the generalized chart, and the steam tables.

Properties The gas constant, the critical pressure, and the critical temperature of water are, from Table A-1,

$$R = 0.4615 \text{ kPa} \cdot \text{m}^3/\text{kg} \cdot \text{K}, \quad T_{\text{cr}} = 647.1 \text{ K}, \quad P_{\text{cr}} = 22.06 \text{ MPa}$$

Analysis (a) From the ideal gas equation of state,

$$P = \frac{RT}{\nu} = \frac{(0.4615 \text{ kPa} \cdot \text{m}^3/\text{kg} \cdot \text{K})(673 \text{ K})}{0.02 \text{ m}^3/\text{kg}} = \mathbf{15,529 \text{ kPa}}$$

H_2O $0.02 \text{ m}^3/\text{kg}$ 400°C

(b) From the compressibility chart (Fig. A-15a),

$$\left. \begin{aligned} T_R &= \frac{T}{T_{\text{cr}}} = \frac{673 \text{ K}}{647.1 \text{ K}} = 1.040 \\ \nu_R &= \frac{\nu_{\text{actual}}}{RT_{\text{cr}}/P_{\text{cr}}} = \frac{(0.02 \text{ m}^3/\text{kg})(22,060 \text{ kPa})}{(0.4615 \text{ kPa} \cdot \text{m}^3/\text{kg} \cdot \text{K})(647.1 \text{ K})} = 1.48 \end{aligned} \right\} P_R = 0.57$$

Thus,

$$P = P_R P_{\text{cr}} = 0.57 \times 22,060 = \mathbf{12,574 \text{ kPa}}$$

(c) From the superheated steam table,

$$\left. \begin{aligned} T &= 400^\circ\text{C} \\ \nu &= 0.02 \text{ m}^3/\text{kg} \end{aligned} \right\} P = \mathbf{12,515 \text{ kPa}} \quad (\text{from EES})$$

3-122 One section of a tank is filled with saturated liquid R-134a while the other side is evacuated. The partition is removed, and the temperature and pressure in the tank are measured. The volume of the tank is to be determined.

Analysis The mass of the refrigerant contained in the tank is

$$m = \frac{\nu_1}{\nu_1} = \frac{0.03 \text{ m}^3}{0.0008580 \text{ m}^3/\text{kg}} = 34.96 \text{ kg}$$

since

$$\nu_1 = \nu_{f@0.9 \text{ MPa}} = 0.0008580 \text{ m}^3/\text{kg}$$

R-134a $P = 0.9 \text{ MPa}$ $\nu = 0.03 \text{ m}^3$	Evacuated
--	-----------

At the final state (Table A-13),

$$\left. \begin{aligned} P_2 &= 280 \text{ kPa} \\ T_2 &= 20^\circ\text{C} \end{aligned} \right\} \nu_2 = 0.07997 \text{ m}^3/\text{kg}$$

Thus,

$$\nu_{\text{tank}} = \nu_2 = m \nu_2 = (34.96 \text{ kg})(0.07997 \text{ m}^3/\text{kg}) = \mathbf{2.80 \text{ m}^3}$$



3-123 Problem 3-122 is reconsidered. The effect of the initial pressure of refrigerant-134 on the volume of the tank is to be investigated as the initial pressure varies from 0.5 MPa to 1.5 MPa. The volume of the tank is to be plotted versus the initial pressure, and the results are to be discussed.

Analysis The problem is solved using EES, and the solution is given below.

"Given Data"

$x_1=0.0$
 $Vol_1=0.03 [m^3]$
 $P_1=1200 [kPa]$
 $T_2=30 [C]$
 $P_2=400 [kPa]$

"Solution"

$v_1=volume(R134a,P=P_1,x=x_1)$
 $Vol_1=m*v_1$
 $v_2=volume(R134a,P=P_2,T=T_2)$
 $Vol_2=m*v_2$

P_1 [kPa]	Vol_2 [m ³]
500	2.977
600	2.926
700	2.88
800	2.837
900	2.796
1000	2.757
1100	2.721
1200	2.685
1300	2.651
1400	2.617
1500	2.584

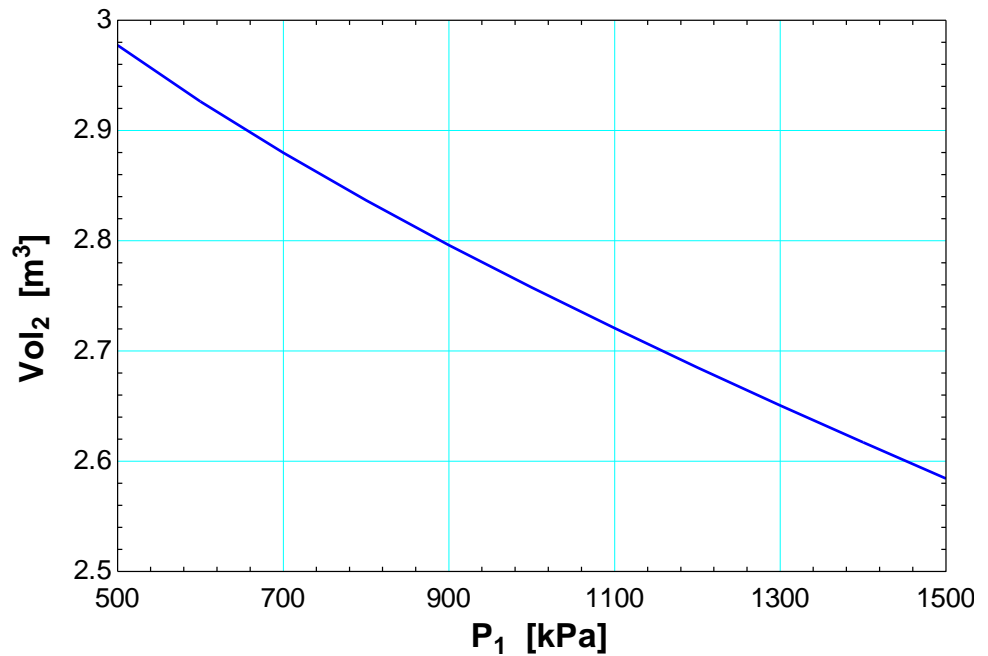

3-124 A propane tank contains 5 L of liquid propane at the ambient temperature. Now a leak develops at the top of the tank and propane starts to leak out. The temperature of propane when the pressure drops to 1 atm and the amount of heat transferred to the tank by the time the entire propane in the tank is vaporized are to be determined.

Properties The properties of propane at 1 atm are $T_{\text{sat}} = -42.1^\circ\text{C}$, $\rho = 581 \text{ kg/m}^3$, and $h_{\text{fg}} = 427.8 \text{ kJ/kg}$ (Table A-3).

Analysis The temperature of propane when the pressure drops to 1 atm is simply the saturation pressure at that temperature,

$$T = T_{\text{sat}@1 \text{ atm}} = -42.1^\circ\text{C}$$

The initial mass of liquid propane is

$$m = \rho V = (581 \text{ kg/m}^3)(0.005 \text{ m}^3) = 2.905 \text{ kg}$$

The amount of heat absorbed is simply the total heat of vaporization,

$$Q_{\text{absorbed}} = mh_{\text{fg}} = (2.905 \text{ kg})(427.8 \text{ kJ/kg}) = \mathbf{1243 \text{ kJ}}$$

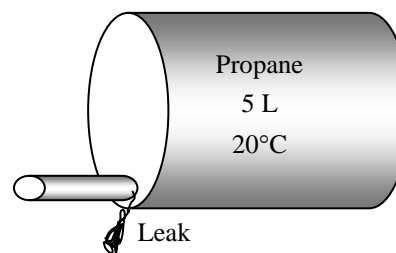

3-125 An isobutane tank contains 5 L of liquid isobutane at the ambient temperature. Now a leak develops at the top of the tank and isobutane starts to leak out. The temperature of isobutane when the pressure drops to 1 atm and the amount of heat transferred to the tank by the time the entire isobutane in the tank is vaporized are to be determined.

Properties The properties of isobutane at 1 atm are $T_{\text{sat}} = -11.7^\circ\text{C}$, $\rho = 593.8 \text{ kg/m}^3$, and $h_{\text{fg}} = 367.1 \text{ kJ/kg}$ (Table A-3).

Analysis The temperature of isobutane when the pressure drops to 1 atm is simply the saturation pressure at that temperature,

$$T = T_{\text{sat}@1 \text{ atm}} = -11.7^\circ\text{C}$$

The initial mass of liquid isobutane is

$$m = \rho V = (593.8 \text{ kg/m}^3)(0.005 \text{ m}^3) = 2.969 \text{ kg}$$

The amount of heat absorbed is simply the total heat of vaporization,

$$Q_{\text{absorbed}} = mh_{\text{fg}} = (2.969 \text{ kg})(367.1 \text{ kJ/kg}) = \mathbf{1090 \text{ kJ}}$$

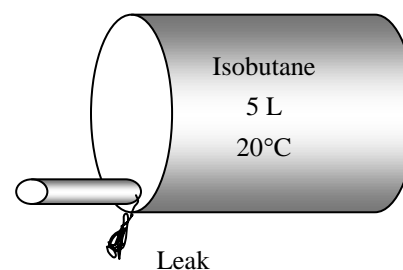

3-126 A tank contains helium at a specified state. Heat is transferred to helium until it reaches a specified temperature. The final gage pressure of the helium is to be determined.

Assumptions 1 Helium is an ideal gas.

Properties The local atmospheric pressure is given to be 100 kPa.

Analysis Noting that the specific volume of helium in the tank remains constant, from ideal gas relation, we have

$$P_2 = P_1 \frac{T_2}{T_1} = (140 + 100 \text{ kPa}) \frac{(300 + 273)\text{K}}{(37 + 273)\text{K}} = 366.2 \text{ kPa}$$

Then the gage pressure becomes

$$P_{\text{gage},2} = P_2 - P_{\text{atm}} = 366.2 - 100 = \mathbf{266 \text{ kPa}}$$

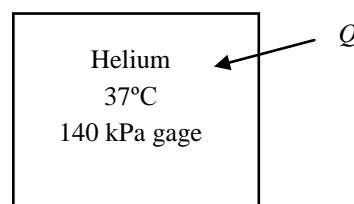

3-127 The table is completed as follows:

P , kPa	T , °C	v , m ³ /kg	u , kJ/kg	Condition description and quality, if applicable
300	250	0.7921	2728.9	Superheated vapor
300	133.52	0.3058	1560.0	$x = 0.504$, Two-phase mixture
101.42	100	-	-	Insufficient information
3000	180	0.001127*	761.92*	Compressed liquid

* Approximated as saturated liquid at the given temperature of 180°C

3-128 Water at a specified state is contained in a piston-cylinder device fitted with stops. Water is now heated until a final pressure. The process will be indicated on the P - v and T - v diagrams.

Analysis The properties at the three states are

$$\left. \begin{aligned} P_1 &= 300 \text{ kPa} \\ v_1 &= 0.5 \text{ m}^3/\text{kg} \end{aligned} \right\} T_1 = 133.5^\circ\text{C} \text{ (Table A - 5)}$$

$$\left. \begin{aligned} P_2 &= 300 \text{ kPa} \\ x_2 &= 1 \text{ (sat. vap.)} \end{aligned} \right\} v_2 = 0.6058 \text{ m}^3/\text{kg}, T_2 = 133.5^\circ\text{C} \text{ (Table A - 5)}$$

$$\left. \begin{aligned} P_3 &= 600 \text{ kPa} \\ v_3 &= 0.6058 \text{ m}^3/\text{kg} \end{aligned} \right\} T_3 = 517.8^\circ\text{C} \text{ (Table A - 6)}$$

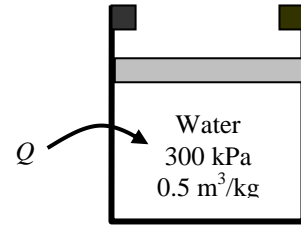

Using Property Plot feature of EES, and by adding state points we obtain following diagrams.

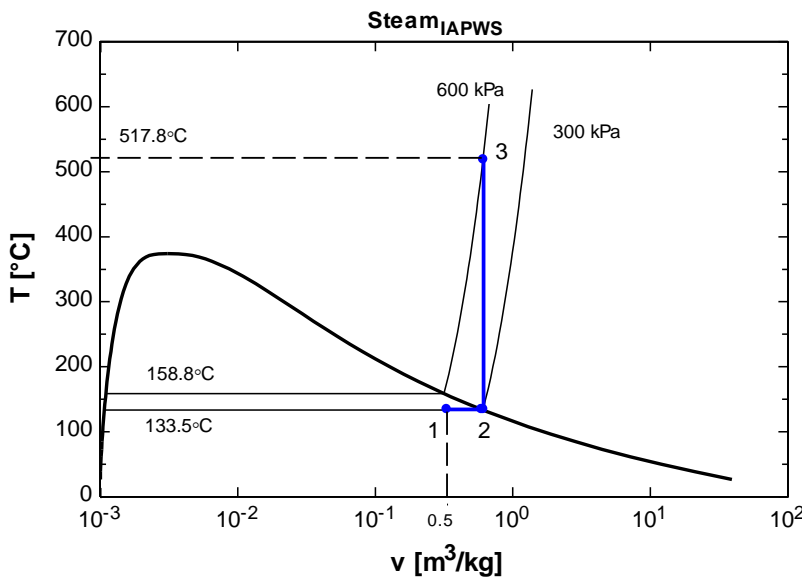
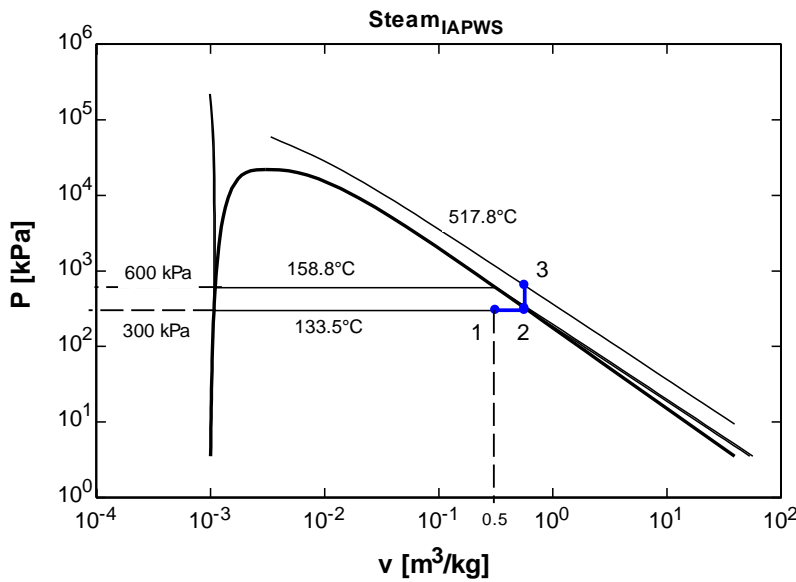

3-129E Argon contained in a piston-cylinder device at a given state undergoes a polytropic process. The final temperature is to be determined using the ideal gas relation and the Beattie-Bridgeman equation.

Analysis (a) The polytropic relations for an ideal gas give

$$T_2 = T_1 \left(\frac{P_2}{P_1} \right)^{n-1/n} = (300 + 460 \text{ R}) \left(\frac{2000 \text{ psia}}{1000 \text{ psia}} \right)^{0.6/1.6} = \mathbf{986 \text{ R}}$$

(b) The constants in the Beattie-Bridgeman equation are expressed as

$$A = A_o \left(1 - \frac{a}{\bar{v}} \right) = 130.7802 \left(1 - \frac{0.02328}{\bar{v}} \right)$$

$$B = B_o \left(1 - \frac{b}{\bar{v}} \right) = 0.03931 \left(1 - \frac{0}{\bar{v}} \right)$$

$$c = 5.99 \times 10^4 \text{ m}^3 \cdot \text{K}^3 / \text{kmol}$$

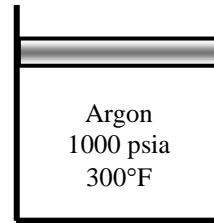

Substituting these coefficients into the Beattie-Bridgeman equation and using data in SI units ($P = 1000 \text{ psia} = 6895 \text{ kPa}$, $T = 760 \text{ R} = 422.2 \text{ K}$, $R_u = 8.314 \text{ kJ/kmol}\cdot\text{K}$)

$$P = \frac{R_u T}{\bar{v}^2} \left(1 - \frac{c}{\bar{v} T^3} \right) (\bar{v} + B) - \frac{A}{\bar{v}^2}$$

and solving using an equation solver such as EES gives

$$\bar{v} = 0.5120 \text{ m}^3 / \text{kmol} = 8.201 \text{ ft}^3 / \text{lbmol}$$

From the polytropic equation

$$\bar{v}_2 = \bar{v}_1 \left(\frac{P_1}{P_2} \right)^{1/n} = (0.5120 \text{ m}^3 / \text{kmol}) \left(\frac{1}{2} \right)^{1/1.6} = 0.3319 \text{ m}^3 / \text{kmol}$$

Substituting this value into the Beattie-Bridgeman equation and using data in SI units ($P = 2000 \text{ psia} = 13790 \text{ kPa}$ and $R_u = 8.314 \text{ kJ/kmol}\cdot\text{K}$),

$$P = \frac{R_u T}{\bar{v}^2} \left(1 - \frac{c}{\bar{v} T^3} \right) (\bar{v} + B) - \frac{A}{\bar{v}^2}$$

and solving using an equation solver such as EES gives

$$T_2 = 532.2 \text{ K} = \mathbf{958 \text{ R}}$$

3-130E The specific volume of nitrogen at a given state is to be determined using the ideal gas relation, the Benedict-Webb-Rubin equation, and the compressibility factor.

Properties The properties of nitrogen are (Table A-1E)

$$R = 0.3830 \text{ psia} \cdot \text{ft}^3/\text{lbm} \cdot \text{R}, \quad M = 28.013 \text{ lbm/lbmol}, \quad T_{\text{cr}} = 227.1 \text{ R}, \quad P_{\text{cr}} = 492 \text{ psia}$$

Analysis (a) From the ideal gas equation of state,

$$\nu = \frac{RT}{P} = \frac{(0.3830 \text{ psia} \cdot \text{ft}^3/\text{lbm} \cdot \text{R})(360 \text{ R})}{400 \text{ psia}} = \mathbf{0.3447 \text{ ft}^3/\text{lbm}}$$

Nitrogen
400 psia, -100°F

(b) Using the coefficients of Table 3-4 for nitrogen and the given data in SI units, the Benedict-Webb-Rubin equation of state is

$$P = \frac{R_u T}{\bar{\nu}} + \left(B_0 R_u T - A_0 - \frac{C_0}{T^2} \right) \frac{1}{\bar{\nu}} + \frac{b R_u T - a}{\bar{\nu}^3} + \frac{a \alpha}{\bar{\nu}^6} + \frac{c}{\bar{\nu}^3 T^2} \left(1 + \frac{\gamma}{\bar{\nu}^2} \right) \exp(-\gamma / \bar{\nu}^2)$$

$$2758 = \frac{(8.314)(200)}{\bar{\nu}_2} + \left(0.04074 \times 8.314 \times 200 - 106.73 - \frac{8.164 \times 10^5}{200^2} \right) \frac{1}{\bar{\nu}^2} + \frac{0.002328 \times 8.314 \times 200 - 2.54}{\bar{\nu}^3}$$

$$+ \frac{2.54 \times 1.272 \times 10^{-4}}{\bar{\nu}^6} + \frac{7.379 \times 10^4}{\bar{\nu}^3 (200)^2} \left(1 + \frac{0.0053}{\bar{\nu}^2} \right) \exp(-0.0053 / \bar{\nu}^2)$$

The solution of this equation by an equation solver such as EES gives

$$\bar{\nu} = 0.5666 \text{ m}^3/\text{kmol}$$

Then,

$$\nu = \frac{\bar{\nu}}{M} = \frac{0.5666 \text{ m}^3/\text{kmol}}{28.013 \text{ kg/kmol}} \left(\frac{16.02 \text{ ft}^3/\text{lbm}}{1 \text{ m}^3/\text{kg}} \right) = \mathbf{0.3240 \text{ ft}^3/\text{lbm}}$$

(c) From the compressibility chart (Fig. A-15),

$$\left. \begin{aligned} T_R = \frac{T}{T_{\text{cr}}} = \frac{360 \text{ R}}{227.1 \text{ R}} = 1.585 \\ P_R = \frac{P}{P_{\text{cr}}} = \frac{400 \text{ psia}}{492 \text{ psia}} = 0.813 \end{aligned} \right\} Z = 0.94$$

Thus,

$$\nu = Z \nu_{\text{ideal}} = (0.94)(0.3447 \text{ ft}^3/\text{lbm}) = \mathbf{0.3240 \text{ ft}^3/\text{lbm}}$$

3-131 A hot air balloon with 3 people in its cage is hanging still in the air. The average temperature of the air in the balloon for two environment temperatures is to be determined.

Assumptions Air is an ideal gas.

Properties The gas constant of air is $R = 0.287 \text{ kPa}\cdot\text{m}^3/\text{kg}\cdot\text{K}$ (Table A-1).

Analysis The buoyancy force acting on the balloon is

$$V_{\text{balloon}} = 4\pi r^3 / 3 = 4\pi(10\text{m})^3 / 3 = 4189\text{m}^3$$

$$\rho_{\text{cool air}} = \frac{P}{RT} = \frac{90 \text{ kPa}}{(0.287 \text{ kPa}\cdot\text{m}^3/\text{kg}\cdot\text{K})(288 \text{ K})} = 1.089 \text{ kg/m}^3$$

$$F_B = \rho_{\text{cool air}} g V_{\text{balloon}} = (1.089 \text{ kg/m}^3)(9.8 \text{ m/s}^2)(4189 \text{ m}^3) \left(\frac{1 \text{ N}}{1 \text{ kg}\cdot\text{m/s}^2} \right) = 44,700 \text{ N}$$

The vertical force balance on the balloon gives

$$F_B = W_{\text{hot air}} + W_{\text{cage}} + W_{\text{people}} = (m_{\text{hot air}} + m_{\text{cage}} + m_{\text{people}})g$$

Substituting,

$$44,700 \text{ N} = (m_{\text{hot air}} + 80 \text{ kg} + 195 \text{ kg})(9.8 \text{ m/s}^2) \left(\frac{1 \text{ N}}{1 \text{ kg}\cdot\text{m/s}^2} \right)$$

which gives

$$m_{\text{hot air}} = 4287 \text{ kg}$$

Therefore, the average temperature of the air in the balloon is

$$T = \frac{PV}{mR} = \frac{(90 \text{ kPa})(4189 \text{ m}^3)}{(4287 \text{ kg})(0.287 \text{ kPa}\cdot\text{m}^3/\text{kg}\cdot\text{K})} = \mathbf{306.5 \text{ K}}$$

Repeating the solution above for an atmospheric air temperature of 30°C gives $\mathbf{323.6 \text{ K}}$ for the average air temperature in the balloon.

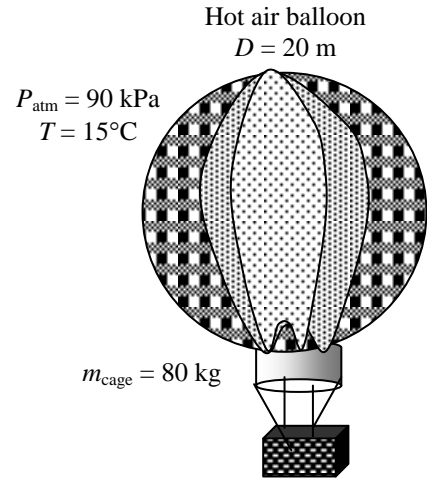



3-132 Problem 3-131 is to be reconsidered. The effect of the environment temperature on the average air temperature in the balloon when the balloon is suspended in the air is to be investigated as the environment temperature varies from -10°C to 30°C . The average air temperature in the balloon is to be plotted versus the environment temperature.

Analysis The problem is solved using EES, and the solution is given below.

"Given Data:"

"atm---atmosphere about balloon"

"gas---heated air inside balloon"

$g=9.807$ [m/s²]

$d_{\text{balloon}}=20$ [m]

$m_{\text{cage}} = 80$ [kg]

$m_{\text{1person}}=65$ [kg]

NoPeople = 6

{ $T_{\text{atm_Celsius}} = 15$ [C]}

$T_{\text{atm}} = T_{\text{atm_Celsius}} + 273$ "[K]"

$P_{\text{atm}} = 90$ [kPa]

$R=0.287$ [kJ/kg-K]

$P_{\text{gas}} = P_{\text{atm}}$

$T_{\text{gas_Celsius}} = T_{\text{gas}} - 273$ "[C]"

"Calculated values:"

$P_{\text{atm}} = \rho_{\text{atm}} * R * T_{\text{atm}}$ " ρ_{atm} = density of air outside balloon"

$P_{\text{gas}} = \rho_{\text{gas}} * R * T_{\text{gas}}$ " ρ_{gas} = density of gas inside balloon"

$r_{\text{balloon}} = d_{\text{balloon}} / 2$

$V_{\text{balloon}} = 4 * \pi * r_{\text{balloon}}^3 / 3$

$m_{\text{people}} = \text{NoPeople} * m_{\text{1person}}$

$m_{\text{gas}} = \rho_{\text{gas}} * V_{\text{balloon}}$

$m_{\text{total}} = m_{\text{gas}} + m_{\text{people}} + m_{\text{cage}}$

"The total weight of balloon, people, and cage is:"

$W_{\text{total}} = m_{\text{total}} * g$

"The buoyancy force acting on the balloon, F_b , is equal to the weight of the air displaced by the balloon."

$F_b = \rho_{\text{atm}} * V_{\text{balloon}} * g$

"From the free body diagram of the balloon, the balancing vertical forces must equal the product of the total mass and the vertical acceleration:"

$F_b - W_{\text{total}} = m_{\text{total}} * a_{\text{up}}$

$a_{\text{up}} = 0$ "The balloon is hanging still in the air"

$T_{\text{atm,Celsius}}$ [C]	$T_{\text{gas,Celsius}}$ [C]
-10	17.32
-5	23.42
0	29.55
5	35.71
10	41.89
15	48.09
20	54.31
25	60.57
30	66.84

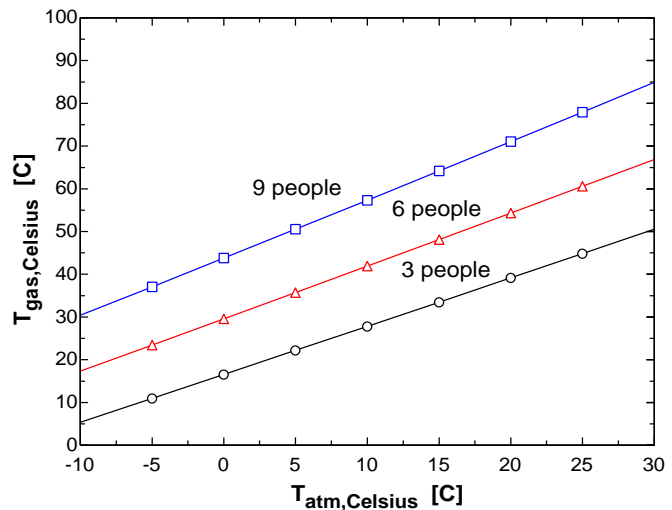

3-133 A hot air balloon with 2 people in its cage is about to take off. The average temperature of the air in the balloon for two environment temperatures is to be determined.

Assumptions Air is an ideal gas.

Properties The gas constant of air is $R = 0.287 \text{ kPa}\cdot\text{m}^3/\text{kg}\cdot\text{K}$.

Analysis The buoyancy force acting on the balloon is

$$V_{\text{balloon}} = 4\pi r^3 / 3 = 4\pi(9 \text{ m})^3 / 3 = 3054 \text{ m}^3$$

$$\rho_{\text{coolair}} = \frac{P}{RT} = \frac{93 \text{ kPa}}{(0.287 \text{ kPa}\cdot\text{m}^3/\text{kg}\cdot\text{K})(285 \text{ K})} = 1.137 \text{ kg/m}^3$$

$$F_B = \rho_{\text{coolair}} g V_{\text{balloon}} = (1.137 \text{ kg/m}^3)(9.8 \text{ m/s}^2)(3054 \text{ m}^3) \left(\frac{1 \text{ N}}{1 \text{ kg}\cdot\text{m/s}^2} \right) = 34,029 \text{ N}$$

The vertical force balance on the balloon gives

$$F_B = W_{\text{hotair}} + W_{\text{cage}} + W_{\text{people}} = (m_{\text{hotair}} + m_{\text{cage}} + m_{\text{people}})g$$

Substituting,

$$34,029 \text{ N} = (m_{\text{hotair}} + 120 \text{ kg} + 140 \text{ kg})(9.81 \text{ m/s}^2) \left(\frac{1 \text{ N}}{1 \text{ kg}\cdot\text{m/s}^2} \right)$$

which gives

$$m_{\text{hotair}} = 3212 \text{ kg}$$

Therefore, the average temperature of the air in the balloon is

$$T = \frac{PV}{mR} = \frac{(93 \text{ kPa})(3054 \text{ m}^3)}{(3212 \text{ kg})(0.287 \text{ kPa}\cdot\text{m}^3/\text{kg}\cdot\text{K})} = \mathbf{308 \text{ K}}$$

Repeating the solution above for an atmospheric air temperature of 25°C gives $\mathbf{323 \text{ K}}$ for the average air temperature in the balloon.

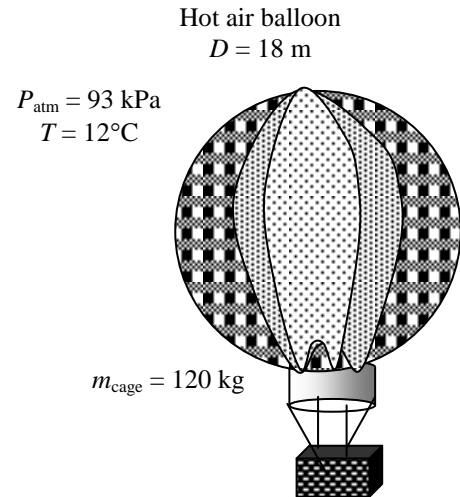

Fundamentals of Engineering (FE) Exam Problems

3-134 A 300-m³ rigid tank is filled with saturated liquid-vapor mixture of water at 200 kPa. If 25% of the mass is liquid and the 75% of the mass is vapor, the total mass in the tank is

- (a) 451 kg (b) 556 kg (c) 300 kg (d) 331 kg (e) 195 kg

Answer (a) 451 kg

Solution Solved by EES Software. Solutions can be verified by copying-and-pasting the following lines on a blank EES screen. (Similar problems and their solutions can be obtained easily by modifying numerical values).

```
V_tank=300 "m3"
P1=200 "kPa"
x=0.75
v_f=VOLUME(Steam_IAPWS, x=0,P=P1)
v_g=VOLUME(Steam_IAPWS, x=1,P=P1)
v=v_f+x*(v_g-v_f)
m=V_tank/v "kg"
"Some Wrong Solutions with Common Mistakes:"
R=0.4615 "kJ/kg.K"
T=TEMPERATURE(Steam_IAPWS,x=0,P=P1)
P1*V_tank=W1_m*R*(T+273) "Treating steam as ideal gas"
P1*V_tank=W2_m*R*T "Treating steam as ideal gas and using deg.C"
W3_m=V_tank "Taking the density to be 1 kg/m^3"
```

3-135 Water is boiled at 1 atm pressure in a coffee maker equipped with an immersion-type electric heating element. The coffee maker initially contains 1 kg of water. Once boiling started, it is observed that half of the water in the coffee maker evaporated in 10 minutes. If the heat loss from the coffee maker is negligible, the power rating of the heating element is

- (a) 3.8 kW (b) 2.2 kW (c) 1.9 kW (d) 1.6 kW (e) 0.8 kW

Answer (c) 1.9 kW

Solution Solved by EES Software. Solutions can be verified by copying-and-pasting the following lines on a blank EES screen. (Similar problems and their solutions can be obtained easily by modifying numerical values).

```
m_1=1 "kg"
P=101.325 "kPa"
time=10*60 "s"
m_evap=0.5*m_1
Power*time=m_evap*h_fg "kJ"
h_f=ENTHALPY(Steam_IAPWS, x=0,P=P)
h_g=ENTHALPY(Steam_IAPWS, x=1,P=P)
h_fg=h_g-h_f
"Some Wrong Solutions with Common Mistakes:"
W1_Power*time=m_evap*h_g "Using h_g"
W2_Power*time/60=m_evap*h_g "Using minutes instead of seconds for time"
W3_Power=2*Power "Assuming all the water evaporates"
```

3-136 A 1-m^3 rigid tank contains 10 kg of water (in any phase or phases) at 160°C . The pressure in the tank is

- (a) 738 kPa (b) 618 kPa (c) 370 kPa (d) 2000 kPa (e) 1618 kPa

Answer (b) 618 kPa

Solution Solved by EES Software. Solutions can be verified by copying-and-pasting the following lines on a blank EES screen. (Similar problems and their solutions can be obtained easily by modifying numerical values).

```
V_tank=1 "m^3"
m=10 "kg"
v=V_tank/m
T=160 "C"
P=PRESSURE(Steam_IAPWS,v=v,T=T)
"Some Wrong Solutions with Common Mistakes:"
R=0.4615 "kJ/kg.K"
W1_P*V_tank=m*R*(T+273) "Treating steam as ideal gas"
W2_P*V_tank=m*R*T "Treating steam as ideal gas and using deg.C"
```

3-137 Water is boiling at 1 atm pressure in a stainless steel pan on an electric range. It is observed that 2 kg of liquid water evaporates in 30 minutes. The rate of heat transfer to the water is

- (a) 2.51 kW (b) 2.32 kW (c) 2.97 kW (d) 0.47 kW (e) 3.12 kW

Answer (a) 2.51 kW

Solution Solved by EES Software. Solutions can be verified by copying-and-pasting the following lines on a blank EES screen. (Similar problems and their solutions can be obtained easily by modifying numerical values).

```
m_evap=2 "kg"
P=101.325 "kPa"
time=30*60 "s"
Q*time=m_evap*h_fg "kJ"
h_f=ENTHALPY(Steam_IAPWS, x=0,P=P)
h_g=ENTHALPY(Steam_IAPWS, x=1,P=P)
h_fg=h_g-h_f
"Some Wrong Solutions with Common Mistakes:"
W1_Q*time=m_evap*h_g "Using h_g"
W2_Q*time/60=m_evap*h_g "Using minutes instead of seconds for time"
W3_Q*time=m_evap*h_f "Using h_f"
```

3-138 Water is boiled in a pan on a stove at sea level. During 10 min of boiling, it is observed that 200 g of water has evaporated. Then the rate of heat transfer to the water is

- (a) 0.84 kJ/min (b) 45.1 kJ/min (c) 41.8 kJ/min (d) 53.5 kJ/min (e) 225.7 kJ/min

Answer (b) 45.1 kJ/min

Solution Solved by EES Software. Solutions can be verified by copying-and-pasting the following lines on a blank EES screen. (Similar problems and their solutions can be obtained easily by modifying numerical values).

```
m_evap=0.2 "kg"
P=101.325 "kPa"
time=10 "min"
Q*time=m_evap*h_fg "kJ"
h_f=ENTHALPY(Steam_IAPWS, x=0,P=P)
h_g=ENTHALPY(Steam_IAPWS, x=1,P=P)
h_fg=h_g-h_f
"Some Wrong Solutions with Common Mistakes:"
W1_Q*time=m_evap*h_g "Using h_g"
W2_Q*time*60=m_evap*h_g "Using seconds instead of minutes for time"
W3_Q*time=m_evap*h_f "Using h_f"
```

3-139 A rigid 3-m³ rigid vessel contains steam at 4 MPa and 500°C. The mass of the steam is

- (a) 3 kg (b) 9 kg (c) 26 kg (d) 35 kg (e) 52 kg

Answer (d) 35 kg

Solution Solved by EES Software. Solutions can be verified by copying-and-pasting the following lines on a blank EES screen. (Similar problems and their solutions can be obtained easily by modifying numerical values).

```
V=3 "m^3"
m=V/v1 "m^3/kg"
P1=4000 "kPa"
T1=500 "C"
v1=VOLUME(Steam_IAPWS,T=T1,P=P1)
"Some Wrong Solutions with Common Mistakes:"
R=0.4615 "kJ/kg.K"
P1*V=W1_m*R*(T1+273) "Treating steam as ideal gas"
P1*V=W2_m*R*T1 "Treating steam as ideal gas and using deg.C"
```

3-140 Consider a sealed can that is filled with refrigerant-134a. The contents of the can are at the room temperature of 25°C. Now a leak develops, and the pressure in the can drops to the local atmospheric pressure of 90 kPa. The temperature of the refrigerant in the can is expected to drop to (rounded to the nearest integer)

- (a) 0°C (b) -29°C (c) -16°C (d) 5°C (e) 25°C

Answer (b) -29°C

Solution Solved by EES Software. Solutions can be verified by copying-and-pasting the following lines on a blank EES screen. (Similar problems and their solutions can be obtained easily by modifying numerical values).

```
T1=25 "C"
P2=90 "kPa"
T2=TEMPERATURE(R134a,x=0,P=P2)
"Some Wrong Solutions with Common Mistakes:"
W1_T2=T1 "Assuming temperature remains constant"
```

3-141 A rigid tank contains 2 kg of an ideal gas at 4 atm and 40°C. Now a valve is opened, and half of mass of the gas is allowed to escape. If the final pressure in the tank is 2.2 atm, the final temperature in the tank is

- (a) 71°C (b) 44°C (c) -100°C (d) 20°C (e) 172°C

Answer (a) 71°C

Solution Solved by EES Software. Solutions can be verified by copying-and-pasting the following lines on a blank EES screen. (Similar problems and their solutions can be obtained easily by modifying numerical values).

```
"When R=constant and V= constant, P1/P2=m1*T1/m2*T2"
m1=2 "kg"
P1=4 "atm"
P2=2.2 "atm"
T1=40+273 "K"
m2=0.5*m1 "kg"
P1/P2=m1*T1/(m2*T2)
T2_C=T2-273 "C"
"Some Wrong Solutions with Common Mistakes:"
P1/P2=m1*(T1-273)/(m2*W1_T2) "Using C instead of K"
P1/P2=m1*T1/(m1*(W2_T2+273)) "Disregarding the decrease in mass"
P1/P2=m1*T1/(m1*W3_T2) "Disregarding the decrease in mass, and not converting to deg. C"
W4_T2=(T1-273)/2 "Taking T2 to be half of T1 since half of the mass is discharged"
```

3-142 The pressure of an automobile tire is measured to be 190 kPa (gage) before a trip and 215 kPa (gage) after the trip at a location where the atmospheric pressure is 95 kPa. If the temperature of air in the tire before the trip is 25°C, the air temperature after the trip is

- (a) 51.1°C (b) 64.2°C (c) 27.2°C (d) 28.3°C (e) 25.0°C

Answer (a) 51.1°C

Solution Solved by EES Software. Solutions can be verified by copying-and-pasting the following lines on a blank EES screen. (Similar problems and their solutions can be obtained easily by modifying numerical values).

"When R, V, and m are constant, $P_1/P_2=T_1/T_2$ "

Patm=95

P1=190+Patm "kPa"

P2=215+Patm "kPa"

T1=25+273 "K"

P1/P2=T1/T2

T2_C=T2-273 "C"

"Some Wrong Solutions with Common Mistakes:"

P1/P2=(T1-273)/W1_T2 "Using C instead of K"

(P1-Patm)/(P2-Patm)=T1/(W2_T2+273) "Using gage pressure instead of absolute pressure"

(P1-Patm)/(P2-Patm)=(T1-273)/W3_T2 "Making both of the mistakes above"

W4_T2=T1-273 "Assuming the temperature to remain constant"

3-143 ... 3-145 Design and Essay Problems

3-145 It is helium.



Solutions Manual for
Thermodynamics: An Engineering Approach
8th Edition
Yunus A. Cengel, Michael A. Boles
McGraw-Hill, 2015

Chapter 4

ENERGY ANALYSIS OF CLOSED SYSTEMS

PROPRIETARY AND CONFIDENTIAL

This Manual is the proprietary property of McGraw-Hill Education and protected by copyright and other state and federal laws. By opening and using this Manual the user agrees to the following restrictions, and if the recipient does not agree to these restrictions, the Manual should be promptly returned unopened to McGraw-Hill Education: **This Manual is being provided only to authorized professors and instructors for use in preparing for the classes using the affiliated textbook. No other use or distribution of this Manual is permitted. This Manual may not be sold and may not be distributed to or used by any student or other third party. No part of this Manual may be reproduced, displayed or distributed in any form or by any means, electronic or otherwise, without the prior written permission of McGraw-Hill Education.**

Moving Boundary Work

4-1C The area under the process curve, and thus the boundary work done, is greater in the constant pressure case.

4-2 Nitrogen gas in a cylinder is compressed at constant temperature until its pressure rises to a specified value. The boundary work done during this process is to be determined.

Assumptions 1 The process is quasi-equilibrium. **2** Nitrogen is an ideal gas.

Analysis The boundary work is determined from its definition to be

$$\begin{aligned} W_{b,\text{out}} &= \int_1^2 P dV = P_1 V_1 \ln \frac{V_2}{V_1} = P_1 V_1 \ln \frac{P_1}{P_2} \\ &= (150 \text{ kPa})(0.2 \text{ m}^3) \left(\ln \frac{150 \text{ kPa}}{800 \text{ kPa}} \right) \left(\frac{1 \text{ kJ}}{1 \text{ kPa} \cdot \text{m}^3} \right) \\ &= \mathbf{-50.2 \text{ kJ}} \end{aligned}$$

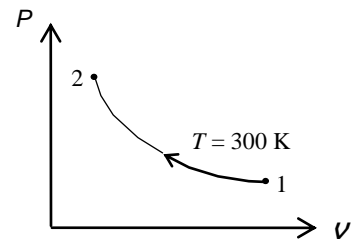

Discussion The negative sign indicates that work is done on the system (work input).

4-3 Helium is compressed in a piston-cylinder device. The initial and final temperatures of helium and the work required to compress it are to be determined.

Assumptions The process is quasi-equilibrium.

Properties The gas constant of helium is $R = 2.0769 \text{ kJ/kg} \cdot \text{K}$ (Table A-1).

Analysis The initial specific volume is

$$v_1 = \frac{V_1}{m} = \frac{5 \text{ m}^3}{1 \text{ kg}} = 5 \text{ m}^3/\text{kg}$$

Using the ideal gas equation,

$$T_1 = \frac{P_1 v_1}{R} = \frac{(180 \text{ kPa})(5 \text{ m}^3/\text{kg})}{2.0769 \text{ kJ/kg} \cdot \text{K}} = \mathbf{433.3 \text{ K}}$$

Since the pressure stays constant,

$$T_2 = \frac{V_2}{V_1} T_1 = \frac{2 \text{ m}^3}{5 \text{ m}^3} (433.3 \text{ K}) = \mathbf{173.3 \text{ K}}$$

and the work integral expression gives

$$W_{b,\text{out}} = \int_1^2 P dV = P(V_2 - V_1) = (180 \text{ kPa})(2 - 5) \text{ m}^3 \left(\frac{1 \text{ kJ}}{1 \text{ kPa} \cdot \text{m}^3} \right) = \mathbf{-540 \text{ kJ}}$$

That is, $W_{b,\text{in}} = \mathbf{540 \text{ kJ}}$

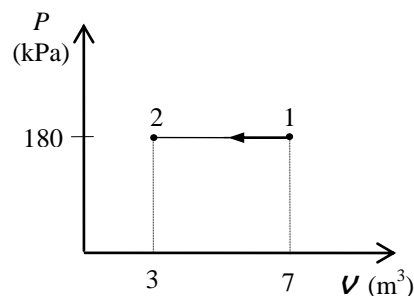

4-4E The boundary work done during the process shown in the figure is to be determined.

Assumptions The process is quasi-equilibrium.

Analysis The work done is equal to the the sumof the areas under the process lines 1-2 and 2-3:

$$\begin{aligned} W_{b,\text{out}} &= \text{Area} = \frac{P_1 + P_2}{2} (\nu_2 - \nu_1) + P_2 (\nu_3 - \nu_2) \\ &= \frac{(300+15)\text{psia}}{2} (3.3-1) \text{ft}^3 \left(\frac{1 \text{ Btu}}{5.404 \text{ psia} \cdot \text{ft}^3} \right) \\ &\quad + (300 \text{ psia})(2 - 3.3) \text{ft}^3 \left(\frac{1 \text{ Btu}}{5.404 \text{ psia} \cdot \text{ft}^3} \right) \\ &= \mathbf{-5.14 \text{ Btu}} \end{aligned}$$

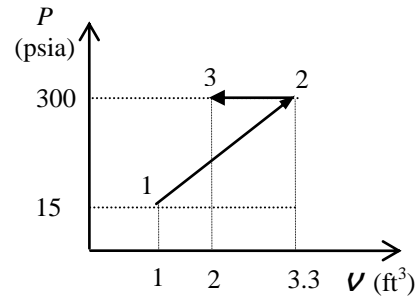

The negative sign shows that the work is done on the system.

4-5 A piston-cylinder device contains nitrogen gas at a specified state. The boundary work is to be determined for the polytropic expansion of nitrogen.

Properties The gas constant for nitrogen is 0.2968 kJ/kg.K (Table A-2).

Analysis The mass and volume of nitrogen at the final state are

$$\begin{aligned} m &= \frac{P_1 \nu_1}{RT_1} = \frac{(130 \text{ kPa})(0.07 \text{ m}^3)}{(0.2968 \text{ kJ/kg} \cdot \text{K})(120 + 273 \text{ K})} = 0.07802 \text{ kg} \\ \nu_2 &= \frac{mRT_2}{P_2} = \frac{(0.07802 \text{ kg})(0.2968 \text{ kPa} \cdot \text{m}^3/\text{kg} \cdot \text{K})(100 + 273 \text{ K})}{100 \text{ kPa}} = 0.08637 \text{ m}^3 \end{aligned}$$

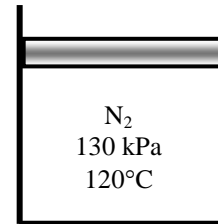

The polytropic index is determined from

$$P_1 \nu_1^n = P_2 \nu_2^n \longrightarrow (130 \text{ kPa})(0.07 \text{ m}^3)^n = (100 \text{ kPa})(0.08637 \text{ m}^3)^n \longrightarrow n = 1.249$$

The boundary work is determined from

$$W_b = \frac{P_2 \nu_2 - P_1 \nu_1}{1-n} = \frac{(100 \text{ kPa})(0.08637 \text{ m}^3) - (130 \text{ kPa})(0.07 \text{ m}^3)}{1-1.249} = \mathbf{1.86 \text{ kJ}}$$

4-6 A piston-cylinder device with a set of stops contains steam at a specified state. Now, the steam is cooled. The compression work for two cases and the final temperature are to be determined.

Analysis (a) The specific volumes for the initial and final states are (Table A-6)

$$\left. \begin{array}{l} P_1 = 1 \text{ MPa} \\ T_1 = 400^\circ\text{C} \end{array} \right\} \nu_1 = 0.30661 \text{ m}^3/\text{kg} \quad \left. \begin{array}{l} P_2 = 1 \text{ MPa} \\ T_2 = 250^\circ\text{C} \end{array} \right\} \nu_2 = 0.23275 \text{ m}^3/\text{kg}$$

Noting that pressure is constant during the process, the boundary work is determined from

$$W_b = mP(\nu_1 - \nu_2) = (0.6 \text{ kg})(1000 \text{ kPa})(0.30661 - 0.23275) \text{ m}^3/\text{kg} = \mathbf{44.3 \text{ kJ}}$$

(b) The volume of the cylinder at the final state is 40% of initial volume. Then, the boundary work becomes

$$W_b = mP(\nu_1 - 0.40\nu_1) = (0.6 \text{ kg})(1000 \text{ kPa})(0.30661 - 0.40 \times 0.30661) \text{ m}^3/\text{kg} = \mathbf{110.4 \text{ kJ}}$$

The temperature at the final state is

$$\left. \begin{array}{l} P_2 = 0.5 \text{ MPa} \\ \nu_2 = (0.40 \times 0.30661) = 0.1226 \text{ m}^3/\text{kg} \end{array} \right\} T_2 = \mathbf{151.8^\circ\text{C}} \quad (\text{Table A-5})$$

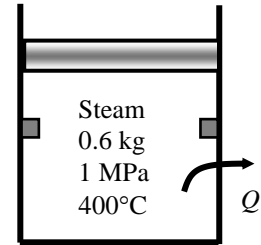

4-7 A piston-cylinder device contains nitrogen gas at a specified state. The final temperature and the boundary work are to be determined for the isentropic expansion of nitrogen.

Properties The properties of nitrogen are $R = 0.2968 \text{ kJ/kg}\cdot\text{K}$, $k = 1.395$ (Tables A-2a, A-2b)

Analysis The mass and the final volume of nitrogen are

$$m = \frac{P_1 V_1}{RT_1} = \frac{(130 \text{ kPa})(0.07 \text{ m}^3)}{(0.2968 \text{ kJ/kg}\cdot\text{K})(180 + 273 \text{ K})} = 0.06768 \text{ kg}$$

$$P_1 V_1^k = P_2 V_2^k \longrightarrow (130 \text{ kPa})(0.07 \text{ m}^3)^{1.395} = (80 \text{ kPa})V_2^{1.395} \longrightarrow V_2 = 0.09914 \text{ m}^3$$

The final temperature and the boundary work are determined as

$$T_2 = \frac{P_2 V_2}{mR} = \frac{(80 \text{ kPa})(0.09914 \text{ m}^3)}{(0.06768 \text{ kg})(0.2968 \text{ kPa}\cdot\text{m}^3/\text{kg}\cdot\text{K})} = \mathbf{395 \text{ K}}$$

$$W_b = \frac{P_2 V_2 - P_1 V_1}{1 - k} = \frac{(80 \text{ kPa})(0.09914 \text{ m}^3) - (130 \text{ kPa})(0.07 \text{ m}^3)}{1 - 1.395} = \mathbf{2.96 \text{ kJ}}$$

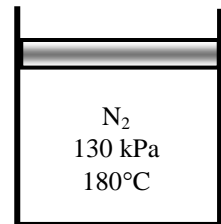

4-8 Saturated water vapor in a cylinder is heated at constant pressure until its temperature rises to a specified value. The boundary work done during this process is to be determined.

Assumptions The process is quasi-equilibrium.

Properties Noting that the pressure remains constant during this process, the specific volumes at the initial and the final states are (Table A-4 through A-6)

$$\left. \begin{array}{l} P_1 = 300 \text{ kPa} \\ \text{Sat. vapor} \end{array} \right\} \nu_1 = \nu_g @ 300 \text{ kPa} = 0.60582 \text{ m}^3/\text{kg}$$

$$\left. \begin{array}{l} P_2 = 300 \text{ kPa} \\ T_2 = 200^\circ\text{C} \end{array} \right\} \nu_2 = 0.71643 \text{ m}^3/\text{kg}$$

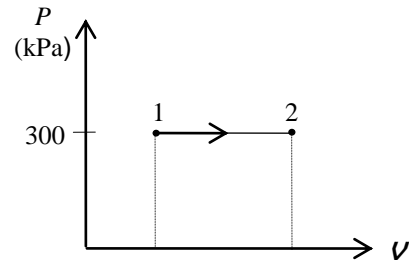

Analysis The boundary work is determined from its definition to be

$$\begin{aligned} W_{b,\text{out}} &= \int_1^2 P d\nu = P(\nu_2 - \nu_1) = mP(\nu_2 - \nu_1) \\ &= (5 \text{ kg})(300 \text{ kPa})(0.71643 - 0.60582) \text{ m}^3/\text{kg} \left(\frac{1 \text{ kJ}}{1 \text{ kPa} \cdot \text{m}^3} \right) \\ &= \mathbf{166 \text{ kJ}} \end{aligned}$$

Discussion The positive sign indicates that work is done by the system (work output).

4-9 Water is expanded isothermally in a closed system. The work produced is to be determined.

Assumptions The process is quasi-equilibrium.

Analysis From water table

$$\begin{aligned} P_1 &= P_2 = P_{\text{sat}} @ 200^\circ\text{C} = 1554.9 \text{ kPa} \\ \nu_1 &= \nu_f @ 200^\circ\text{C} = 0.001157 \text{ m}^3/\text{kg} \\ \nu_2 &= \nu_f + x\nu_{fg} \\ &= 0.001157 + 0.80(0.12721 - 0.001157) \\ &= 0.10200 \text{ m}^3/\text{kg} \end{aligned}$$

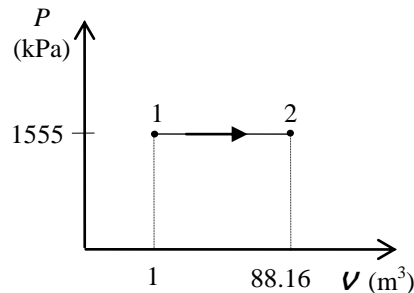

The definition of specific volume gives

$$\nu_2 = \nu_1 \frac{\nu_2}{\nu_1} = (1 \text{ m}^3) \frac{0.10200 \text{ m}^3/\text{kg}}{0.001157 \text{ m}^3/\text{kg}} = 88.16 \text{ m}^3$$

The work done during the process is determined from

$$W_{b,\text{out}} = \int_1^2 P d\nu = P(\nu_2 - \nu_1) = (1554.9 \text{ kPa})(88.16 - 1) \text{ m}^3 \left(\frac{1 \text{ kJ}}{1 \text{ kPa} \cdot \text{m}^3} \right) = \mathbf{1.355 \times 10^5 \text{ kJ}}$$

4-10 A gas in a cylinder is compressed to a specified volume in a process during which the pressure changes linearly with volume. The boundary work done during this process is to be determined by plotting the process on a P - \mathcal{V} diagram and also by integration.

Assumptions The process is quasi-equilibrium.

Analysis (a) The pressure of the gas changes linearly with volume, and thus the process curve on a P - \mathcal{V} diagram will be a straight line. The boundary work during this process is simply the area under the process curve, which is a trapezoidal. Thus,

$$P_1 = a\mathcal{V}_1 + b = (-1200 \text{ kPa/m}^3)(0.42 \text{ m}^3) + (600 \text{ kPa}) = 96 \text{ kPa}$$

$$P_2 = a\mathcal{V}_2 + b = (-1200 \text{ kPa/m}^3)(0.12 \text{ m}^3) + (600 \text{ kPa}) = 456 \text{ kPa}$$

and

$$\begin{aligned} W_{b,\text{out}} &= \text{Area} = \frac{P_1 + P_2}{2} (\mathcal{V}_2 - \mathcal{V}_1) \\ &= \frac{(96 + 456) \text{ kPa}}{2} (0.12 - 0.42) \text{ m}^3 \left(\frac{1 \text{ kJ}}{1 \text{ kPa} \cdot \text{m}^3} \right) \\ &= \mathbf{-82.8 \text{ kJ}} \end{aligned}$$

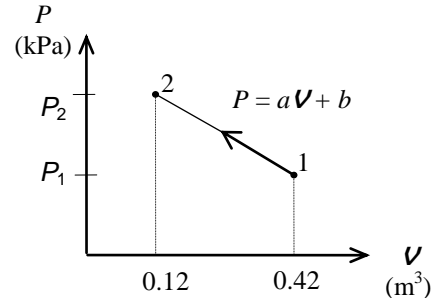

(b) The boundary work can also be determined by integration to be

$$\begin{aligned} W_{b,\text{out}} &= \int_1^2 P d\mathcal{V} = \int_1^2 (a\mathcal{V} + b) d\mathcal{V} = a \frac{\mathcal{V}_2^2 - \mathcal{V}_1^2}{2} + b(\mathcal{V}_2 - \mathcal{V}_1) \\ &= (-1200 \text{ kPa/m}^3) \frac{(0.12^2 - 0.42^2) \text{ m}^6}{2} + (600 \text{ kPa})(0.12 - 0.42) \text{ m}^3 \\ &= \mathbf{-82.8 \text{ kJ}} \end{aligned}$$

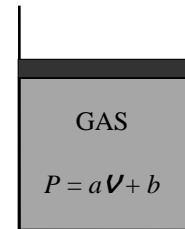

Discussion The negative sign indicates that work is done on the system (work input).

4-11 Air in a cylinder is compressed at constant temperature until its pressure rises to a specified value. The boundary work done during this process is to be determined.

Assumptions 1 The process is quasi-equilibrium. **2** Air is an ideal gas.

Properties The gas constant of air is $R = 0.287 \text{ kJ/kg} \cdot \text{K}$ (Table A-1).

Analysis The boundary work is determined from its definition to be

$$\begin{aligned} W_{b,\text{out}} &= \int_1^2 P d\mathcal{V} = P_1 \mathcal{V}_1 \ln \frac{\mathcal{V}_2}{\mathcal{V}_1} = mRT \ln \frac{P_1}{P_2} \\ &= (1.5 \text{ kg})(0.287 \text{ kJ/kg} \cdot \text{K})(297 \text{ K}) \ln \frac{120 \text{ kPa}}{600 \text{ kPa}} \\ &= \mathbf{-206 \text{ kJ}} \end{aligned}$$

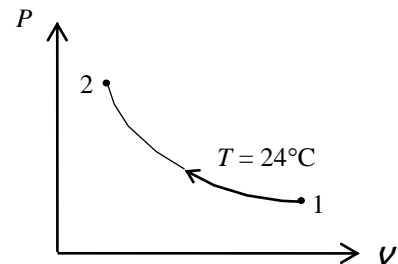

Discussion The negative sign indicates that work is done on the system (work input).

4-12  A gas in a cylinder expands polytropically to a specified volume. The boundary work done during this process is to be determined.

Assumptions The process is quasi-equilibrium.

Analysis The boundary work for this polytropic process can be determined directly from

$$P_2 = P_1 \left(\frac{V_1}{V_2} \right)^n = (350 \text{ kPa}) \left(\frac{0.03 \text{ m}^3}{0.2 \text{ m}^3} \right)^{1.5} = 20.33 \text{ kPa}$$

and

$$\begin{aligned} W_{b,\text{out}} &= \int_1^2 P dV = \frac{P_2 V_2 - P_1 V_1}{1 - n} \\ &= \frac{(20.33 \times 0.2 - 350 \times 0.03) \text{ kPa} \cdot \text{m}^3}{1 - 1.5} \left(\frac{1 \text{ kJ}}{1 \text{ kPa} \cdot \text{m}^3} \right) \\ &= \mathbf{12.9 \text{ kJ}} \end{aligned}$$

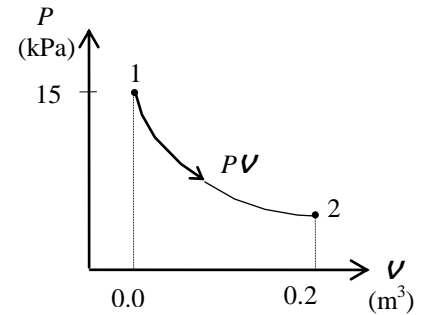

Discussion The positive sign indicates that work is done by the system (work output).



4-13 Problem 4-12 is reconsidered. The process described in the problem is to be plotted on a P - V diagram, and the effect of the polytropic exponent n on the boundary work as the polytropic exponent varies from 1.1 to 1.6 is to be plotted.

Analysis The problem is solved using EES, and the solution is given below.

Function BoundWork(P[1],V[1],P[2],V[2],n)

"This function returns the Boundary Work for the polytropic process. This function is required since the expression for boundary work depends on whether $n=1$ or $n < 1$ "

```
If n <> 1 then
  BoundWork:=(P[2]*V[2]-P[1]*V[1])/(1-n) "Use Equation 3-22 when n=1"
else
  BoundWork:= P[1]*V[1]*ln(V[2]/V[1]) "Use Equation 3-20 when n=1"
endif
end
```

"Inputs from the diagram window"

```
{n=1.5
P[1] = 350 [kPa]
V[1] = 0.03 [m^3]
V[2] = 0.2 [m^3]
Gas$='AIR'}
"System: The gas enclosed in the piston-cylinder device."
"Process: Polytropic expansion or compression,  $P \cdot V^n = C$ "
P[2]*V[2]^n=P[1]*V[1]^n
"n = 1.3" "Polytropic exponent"
```

"Input Data"

```
W_b = BoundWork(P[1],V[1],P[2],V[2],n)"[kJ]"
"If we modify this problem and specify the mass, then we can calculate the final temperature of
the fluid for compression or expansion"
m[1] = m[2] "Conservation of mass for the closed system"
"Let's solve the problem for m[1] = 0.05 kg"
m[1] = 0.05 [kg]
```

"Find the temperatures from the pressure and specific volume."

```
T[1]=temperature(gas$,P=P[1],v=V[1]/m[1])
T[2]=temperature(gas$,P=P[2],v=V[2]/m[2])
```

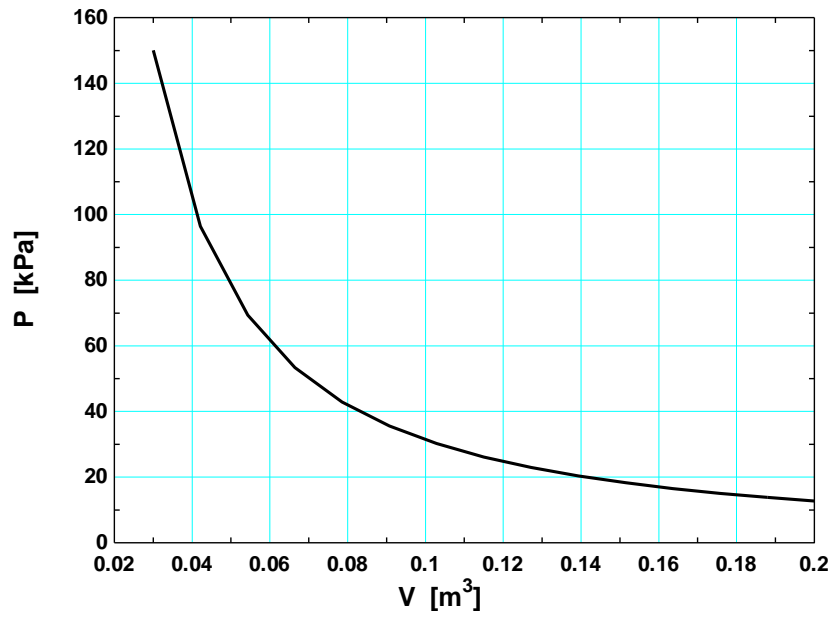

n	W_b [kJ]
1.1	18.14
1.156	17.25
1.211	16.41
1.267	15.63
1.322	14.9
1.378	14.22
1.433	13.58
1.489	12.98
1.544	12.42
1.6	11.89

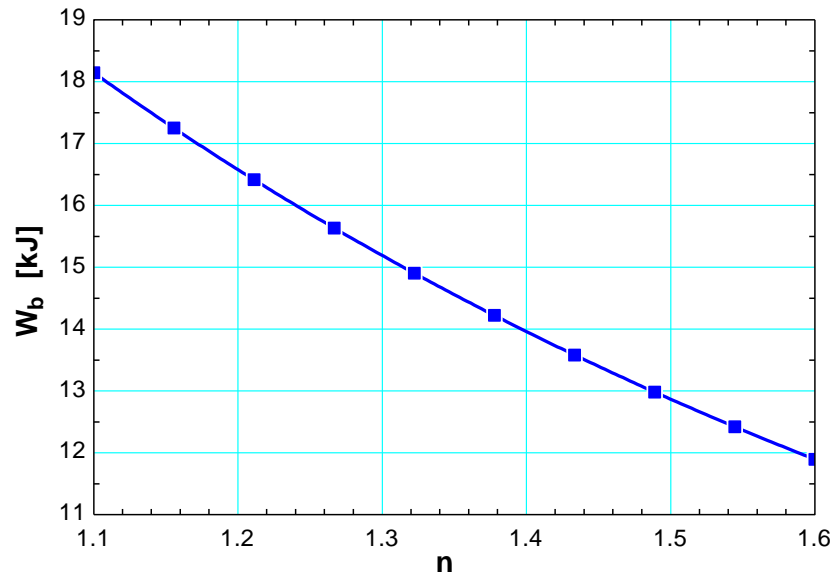

4-14 Nitrogen gas in a cylinder is compressed polytropically until the temperature rises to a specified value. The boundary work done during this process is to be determined.

Assumptions 1 The process is quasi-equilibrium. **2** Nitrogen is an ideal gas.

Properties The gas constant for nitrogen is $R = 0.2968 \text{ kJ/kg}\cdot\text{K}$ (Table A-2a)

Analysis The boundary work for this polytropic process can be determined from

$$\begin{aligned} W_{b,\text{out}} &= \int_1^2 P dV = \frac{P_2 V_2 - P_1 V_1}{1-n} = \frac{mR(T_2 - T_1)}{1-n} \\ &= \frac{(5 \text{ kg})(0.2968 \text{ kJ/kg}\cdot\text{K})(360 - 250)\text{K}}{1-1.4} \\ &= \mathbf{-408 \text{ kJ}} \end{aligned}$$

Discussion The negative sign indicates that work is done on the system (work input).

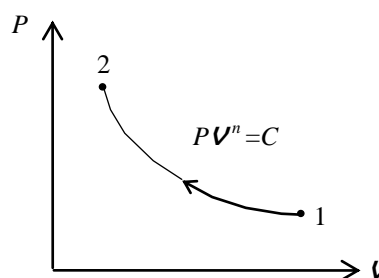

4-15  A gas whose equation of state is $\bar{v}(P + 10/\bar{v}^2) = R_u T$ expands in a cylinder isothermally to a specified volume. The unit of the quantity 10 and the boundary work done during this process are to be determined.

Assumptions The process is quasi-equilibrium.

Analysis (a) The term $10/\bar{v}^2$ must have pressure units since it is added to P .

Thus the quantity 10 must have the unit $\text{kPa}\cdot\text{m}^6/\text{kmol}^2$.

(b) The boundary work for this process can be determined from

$$P = \frac{R_u T}{\bar{v}} - \frac{10}{\bar{v}^2} = \frac{R_u T}{V/N} - \frac{10}{(V/N)^2} = \frac{NR_u T}{V} - \frac{10N^2}{V^2}$$

and

$$\begin{aligned} W_{b,\text{out}} &= \int_1^2 P dV = \int_1^2 \left(\frac{NR_u T}{V} - \frac{10N^2}{V^2} \right) dV = NR_u T \ln \frac{V_2}{V_1} + 10N^2 \left(\frac{1}{V_2} - \frac{1}{V_1} \right) \\ &= (0.2 \text{ kmol})(8.314 \text{ kJ/kmol}\cdot\text{K})(350 \text{ K}) \ln \frac{4 \text{ m}^3}{2 \text{ m}^3} \\ &\quad + (10 \text{ kPa}\cdot\text{m}^6/\text{kmol}^2)(0.5 \text{ kmol})^2 \left(\frac{1}{4 \text{ m}^3} - \frac{1}{2 \text{ m}^3} \right) \left(\frac{1 \text{ kJ}}{1 \text{ kPa}\cdot\text{m}^3} \right) \\ &= \mathbf{403 \text{ kJ}} \end{aligned}$$

Discussion The positive sign indicates that work is done by the system (work output).

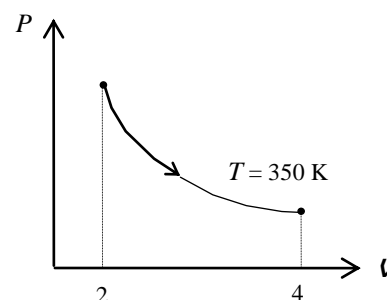



4-16 Problem 4-15 is reconsidered. Using the integration feature, the work done is to be calculated and compared, and the process is to be plotted on a P - \bar{V} diagram.

Analysis The problem is solved using EES, and the solution is given below.

"Input Data"

N=0.2 [kmol]
 $v1_bar=2/N$ "[m³/kmol]"
 $v2_bar=4/N$ "[m³/kmol]"
 T=350 [K]
 $R_u=8.314$ [kJ/kmol-K]

"The equation of state is:"

$v_bar*(P+10/v_bar^2)=R_u*T$ "P is in kPa"

"using the EES integral function, the boundary work, W_bEES , is"

$W_b_EES=N*integral(P,v_bar,v1_bar,v2_bar,0.01)$

"We can show that $W_bhand=$ integral of Pdv_bar is (one should solve for $P=F(v_bar)$ and do the integral 'by hand' for practice)."

$W_b_hand = N*(R_u*T*ln(v2_bar/v1_bar) + 10*(1/v2_bar-1/v1_bar))$

"To plot P vs v_bar , define $P_plot = f(v_bar_plot, T)$ as"

$\{v_bar_plot*(P_plot+10/v_bar_plot^2)=R_u*T\}$

" $P=P_plot$ and $v_bar=v_bar_plot$ just to generate the parametric table for plotting purposes. To plot P vs v_bar for a new temperature or v_bar_plot range, remove the '{' and '}' from the above equation, and reset the v_bar_plot values in the Parametric Table. Then press F3 or select Solve Table from the Calculate menu. Next select New Plot Window under the Plot menu to plot the new data."

P_{plot}	V_{plot}
290.9	10
261.8	11.11
238	12.22
218.2	13.33
201.4	14.44
187	15.56
174.6	16.67
163.7	17.78
154	18.89
145.5	20

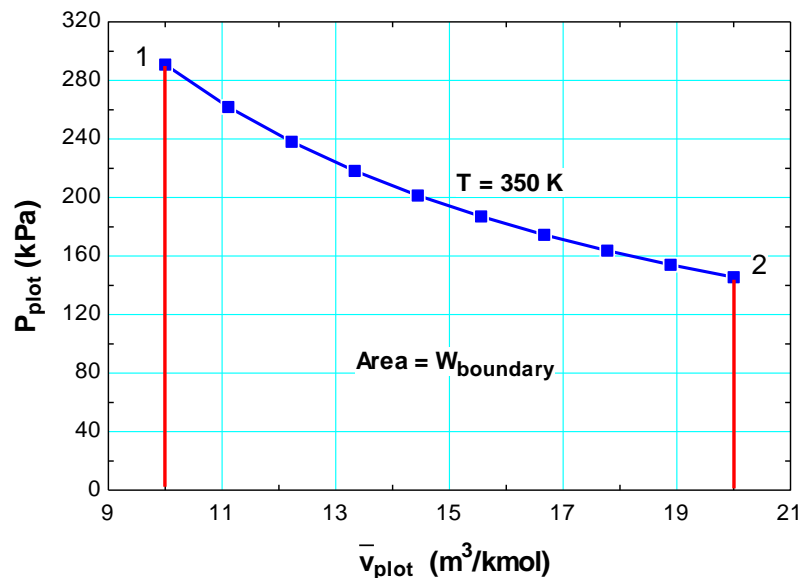

4-17E A gas in a cylinder is heated and is allowed to expand to a specified pressure in a process during which the pressure changes linearly with volume. The boundary work done during this process is to be determined.

Assumptions The process is quasi-equilibrium.

Analysis (a) The pressure of the gas changes linearly with volume, and thus the process curve on a P- \mathcal{V} diagram will be a straight line. The boundary work during this process is simply the area under the process curve, which is a trapezoidal. Thus,

At state 1:

$$\begin{aligned} P_1 &= a\mathcal{V}_1 + b \\ 15 \text{ psia} &= (5 \text{ psia/ft}^3)(7 \text{ ft}^3) + b \\ b &= -20 \text{ psia} \end{aligned}$$

At state 2:

$$\begin{aligned} P_2 &= a\mathcal{V}_2 + b \\ 100 \text{ psia} &= (5 \text{ psia/ft}^3)\mathcal{V}_2 + (-20 \text{ psia}) \\ \mathcal{V}_2 &= 24 \text{ ft}^3 \end{aligned}$$

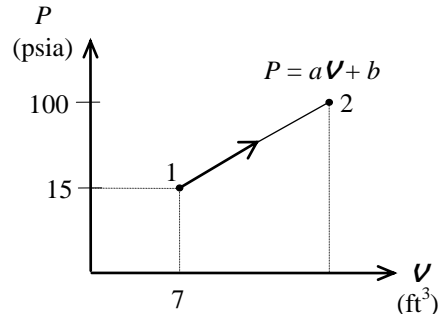

and,

$$\begin{aligned} W_{b,\text{out}} &= \text{Area} = \frac{P_1 + P_2}{2} (\mathcal{V}_2 - \mathcal{V}_1) = \frac{(100 + 15) \text{ psia}}{2} (24 - 7) \text{ ft}^3 \left(\frac{1 \text{ Btu}}{5.4039 \text{ psia} \cdot \text{ft}^3} \right) \\ &= \mathbf{181 \text{ Btu}} \end{aligned}$$

Discussion The positive sign indicates that work is done by the system (work output).

4-18 A piston-cylinder device contains nitrogen gas at a specified state. The boundary work is to be determined for the isothermal expansion of nitrogen.

Properties The properties of nitrogen are $R = 0.2968 \text{ kJ/kg} \cdot \text{K}$, $k = 1.4$ (Table A-2a).

Analysis We first determine initial and final volumes from ideal gas relation, and find the boundary work using the relation for isothermal expansion of an ideal gas

$$\begin{aligned} \mathcal{V}_1 &= \frac{mRT}{P_1} = \frac{(0.4 \text{ kg})(0.2968 \text{ kJ/kg} \cdot \text{K})(140 + 273 \text{ K})}{160 \text{ kPa}} = 0.3064 \text{ m}^3 \\ \mathcal{V}_2 &= \frac{mRT}{P_2} = \frac{(0.4 \text{ kg})(0.2968 \text{ kJ/kg} \cdot \text{K})(140 + 273 \text{ K})}{100 \text{ kPa}} = 0.4903 \text{ m}^3 \\ W_b &= P_1 \mathcal{V}_1 \ln \left(\frac{\mathcal{V}_2}{\mathcal{V}_1} \right) = (160 \text{ kPa})(0.3064 \text{ m}^3) \ln \left(\frac{0.4903 \text{ m}^3}{0.3064 \text{ m}^3} \right) = \mathbf{23.0 \text{ kJ}} \end{aligned}$$

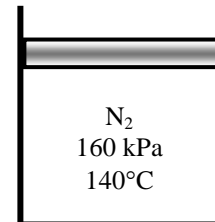

4-19E Hydrogen gas in a cylinder equipped with a spring is heated. The gas expands and compresses the spring until its volume doubles. The final pressure, the boundary work done by the gas, and the work done against the spring are to be determined, and a P - \mathcal{V} diagram is to be drawn.

Assumptions 1 The process is quasi-equilibrium. **2** Hydrogen is an ideal gas.

Analysis (a) When the volume doubles, the spring force and the final pressure of H_2 becomes

$$F_s = kx_2 = k \frac{\Delta \mathcal{V}}{A} = (15,000 \text{ lbf/ft}) \frac{15 \text{ ft}^3}{3 \text{ ft}^2} = 75,000 \text{ lbf}$$

$$P_2 = P_1 + \frac{F_s}{A} = (14.7 \text{ psia}) + \frac{75,000 \text{ lbf}}{3 \text{ ft}^2} \left(\frac{1 \text{ ft}^2}{144 \text{ in}^2} \right) = \mathbf{188.3 \text{ psia}}$$

(b) The pressure of H_2 changes linearly with volume during this process, and thus the process curve on a P - \mathcal{V} diagram will be a straight line. Then the boundary work during this process is simply the area under the process curve, which is a trapezoid. Thus,

$$\begin{aligned} W_{b,\text{out}} &= \text{Area} = \frac{P_1 + P_2}{2} (\mathcal{V}_2 - \mathcal{V}_1) \\ &= \frac{(188.3 + 14.7) \text{ psia}}{2} (30 - 15) \text{ ft}^3 \left(\frac{1 \text{ Btu}}{5.40395 \text{ psia} \cdot \text{ft}^3} \right) = \mathbf{281.7 \text{ Btu}} \end{aligned}$$

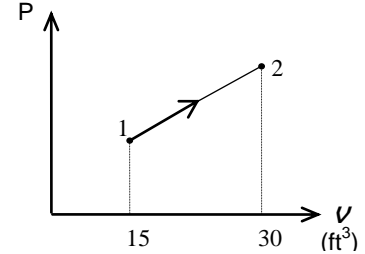

(c) If there were no spring, we would have a constant pressure process at $P = 14.7$ psia. The work done during this process would be

$$\begin{aligned} W_{b,\text{out,no spring}} &= \int_1^2 P d\mathcal{V} = P(\mathcal{V}_2 - \mathcal{V}_1) \\ &= (14.7 \text{ psia})(30 - 15) \text{ ft}^3 \left(\frac{1 \text{ Btu}}{5.40395 \text{ psia} \cdot \text{ft}^3} \right) = 40.8 \text{ Btu} \end{aligned}$$

Thus,

$$W_{\text{spring}} = W_b - W_{b,\text{no spring}} = 281.7 - 40.8 = \mathbf{240.9 \text{ Btu}}$$

Discussion The positive sign for boundary work indicates that work is done by the system (work output).

4-20 A piston-cylinder device contains air gas at a specified state. The air undergoes a cycle with three processes. The boundary work for each process and the net work of the cycle are to be determined.

Properties The properties of air are $R = 0.287 \text{ kJ/kg}\cdot\text{K}$, $k = 1.4$ (Table A-2a).

Analysis For the isothermal expansion process:

$$V_1 = \frac{mRT}{P_1} = \frac{(0.15 \text{ kg})(0.287 \text{ kJ/kg}\cdot\text{K})(350 + 273 \text{ K})}{(2000 \text{ kPa})} = 0.01341 \text{ m}^3$$

$$V_2 = \frac{mRT}{P_2} = \frac{(0.15 \text{ kg})(0.287 \text{ kJ/kg}\cdot\text{K})(350 + 273 \text{ K})}{(500 \text{ kPa})} = 0.05364 \text{ m}^3$$

$$W_{b,1-2} = P_1 V_1 \ln\left(\frac{V_2}{V_1}\right) = (2000 \text{ kPa})(0.01341 \text{ m}^3) \ln\left(\frac{0.05364 \text{ m}^3}{0.01341 \text{ m}^3}\right) = \mathbf{37.18 \text{ kJ}}$$

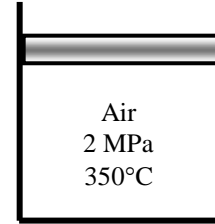

For the polytropic compression process:

$$P_2 V_2^n = P_3 V_3^n \longrightarrow (500 \text{ kPa})(0.05364 \text{ m}^3)^{1.2} = (2000 \text{ kPa}) V_3^{1.2} \longrightarrow V_3 = 0.01690 \text{ m}^3$$

$$W_{b,2-3} = \frac{P_3 V_3 - P_2 V_2}{1-n} = \frac{(2000 \text{ kPa})(0.01690 \text{ m}^3) - (500 \text{ kPa})(0.05364 \text{ m}^3)}{1-1.2} = \mathbf{-34.86 \text{ kJ}}$$

For the constant pressure compression process:

$$W_{b,3-1} = P_3 (V_1 - V_3) = (2000 \text{ kPa})(0.01341 - 0.01690) \text{ m}^3 = \mathbf{-6.97 \text{ kJ}}$$

The net work for the cycle is the sum of the works for each process

$$W_{\text{net}} = W_{b,1-2} + W_{b,2-3} + W_{b,3-1} = 37.18 + (-34.86) + (-6.97) = \mathbf{-4.65 \text{ kJ}}$$

4-21 A saturated water mixture contained in a spring-loaded piston-cylinder device is heated until the pressure and temperature rises to specified values. The work done during this process is to be determined.

Assumptions The process is quasi-equilibrium.

Analysis The initial state is saturated mixture at 90°C . The pressure and the specific volume at this state are (Table A-4),

$$P_1 = 70.183 \text{ kPa}$$

$$\begin{aligned} v_1 &= v_f + x v_{fg} \\ &= 0.001036 + (0.10)(2.3593 - 0.001036) \\ &= 0.23686 \text{ m}^3/\text{kg} \end{aligned}$$

The final specific volume at 800 kPa and 250°C is (Table A-6)

$$v_2 = 0.29321 \text{ m}^3/\text{kg}$$

Since this is a linear process, the work done is equal to the area under the process line 1-2:

$$\begin{aligned} W_{b,\text{out}} &= \text{Area} = \frac{P_1 + P_2}{2} m(v_2 - v_1) \\ &= \frac{(70.183 + 800) \text{ kPa}}{2} (1 \text{ kg})(0.29321 - 0.23686) \text{ m}^3 \left(\frac{1 \text{ kJ}}{1 \text{ kPa}\cdot\text{m}^3} \right) \\ &= \mathbf{24.52 \text{ kJ}} \end{aligned}$$

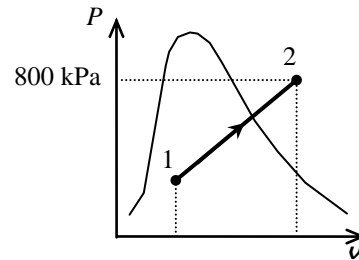

4-22 A saturated water mixture contained in a spring-loaded piston-cylinder device is cooled until it is saturated liquid at a specified temperature. The work done during this process is to be determined.

Assumptions The process is quasi-equilibrium.

Analysis The initial state is saturated mixture at 0.5 MPa. The specific volume at this state is (Table A-5),

$$\begin{aligned} \nu_1 &= \nu_f + x\nu_{fg} \\ &= 0.001093 + (0.30)(0.37483 - 0.001093) \\ &= 0.11321 \text{ m}^3/\text{kg} \end{aligned}$$

The final state is saturated liquid at 100°C (Table A-4)

$$\begin{aligned} P_2 &= 101.42 \text{ kPa} \\ \nu_2 &= \nu_f = 0.001043 \text{ m}^3/\text{kg} \end{aligned}$$

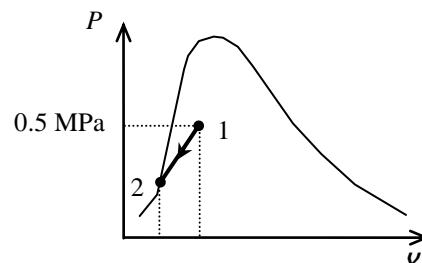

Since this is a linear process, the work done is equal to the area under the process line 1-2:

$$\begin{aligned} W_{b,\text{out}} &= \text{Area} = \frac{P_1 + P_2}{2} m(\nu_2 - \nu_1) \\ &= \frac{(500 + 101.42)\text{kPa}}{2} (0.75 \text{ kg})(0.001043 - 0.11321)\text{m}^3 \left(\frac{1 \text{ kJ}}{1 \text{ kPa} \cdot \text{m}^3} \right) \\ &= \mathbf{-25.3 \text{ kJ}} \end{aligned}$$

The negative sign shows that the work is done on the system in the amount of 25.3 kJ.

4-23 An ideal gas undergoes two processes in a piston-cylinder device. The process is to be sketched on a P - V diagram; an expression for the ratio of the compression to expansion work is to be obtained and this ratio is to be calculated for given values of n and r .

Assumptions The process is quasi-equilibrium.

Analysis (a) The processes on a P - V diagram is as follows:

(b) The ratio of the compression-to-expansion work is called the back-work ratio BWR.

$$\text{Process 1-2: } W_{b,1-2} = \int_1^2 P dV$$

The process is $PV^n = \text{constant}$, $P = \frac{\text{constant}}{V^n}$, and the integration results in

$$W_{b,1-2} = \frac{P_2 V_2 - P_1 V_1}{1-n} = \frac{mR(T_2 - T_1)}{1-n}$$

where the ideal gas law has been used. However, the compression work is

$$W_{\text{comp}} = -W_{b,1-2} = \frac{mR(T_2 - T_1)}{n-1}$$

$$\text{Process 2-3: } W_{b,2-3} = \int_2^3 P dV$$

The process is $P = \text{constant}$ and the integration gives

$$W_{b,2-3} = P(V_3 - V_2)$$

where $P = P_2 = P_3$. Using the ideal gas law, the expansion work is

$$W_{\text{exp}} = W_{b,2-3} = mR(T_3 - T_2)$$

The back-work ratio is defined as

$$BWR = \frac{W_{\text{comp}}}{W_{\text{exp}}} = \frac{\frac{mR(T_2 - T_1)}{n-1}}{mR(T_3 - T_2)} = \frac{1}{n-1} \frac{(T_2 - T_1)}{(T_3 - T_2)} = \frac{1}{n-1} \frac{T_2}{T_2} \frac{(1 - T_1/T_2)}{(T_3/T_2 - 1)} = \frac{1}{n-1} \frac{(1 - T_1/T_2)}{(T_3/T_2 - 1)}$$

Since process 1-2 is polytropic, the temperature-volume relation for the ideal gas is

$$\frac{T_1}{T_2} = \left(\frac{V_2}{V_1} \right)^{n-1} = \left(\frac{1}{r} \right)^{n-1} = r^{1-n}$$

where r is the compression ratio V_1/V_2 . Since process 2-3 is constant pressure, the combined ideal gas law gives

$$\frac{P_3 V_3}{T_3} = \frac{P_2 V_2}{T_2} \text{ and } P_3 = P_2, \text{ then } \frac{T_3}{T_2} = \frac{V_3}{V_2} = \frac{V_1}{V_2} = r$$

The back-work ratio becomes

$$BWR = \frac{1}{n-1} \frac{(1 - r^{1-n})}{(r - 1)}$$

(c) For $n = 1.4$ and $r = 6$, the value of the BWR is

$$BWR = \frac{1}{1.4-1} \frac{(1 - 6^{1-1.4})}{(6-1)} = \mathbf{0.256}$$

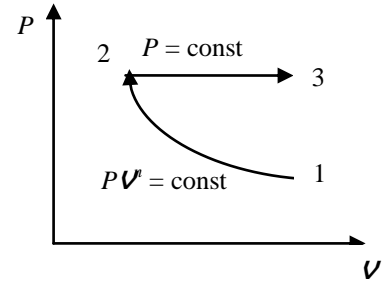

4-24 Water in a cylinder equipped with a spring is heated and evaporated. The vapor expands until it compresses the spring 20 cm. The final pressure and temperature, and the boundary work done are to be determined, and the process is to be shown on a P - ν diagram.

Assumptions The process is quasi-equilibrium.

Analysis (a) The final pressure is determined from

$$P_3 = P_2 + \frac{F_s}{A} = P_2 + \frac{kx}{A} = (250 \text{ kPa}) + \frac{(100 \text{ kN/m})(0.2 \text{ m})}{0.1 \text{ m}^2} \left(\frac{1 \text{ kPa}}{1 \text{ kN/m}^2} \right) = \mathbf{450 \text{ kPa}}$$

The specific and total volumes at the three states are

$$\left. \begin{array}{l} T_1 = 25^\circ\text{C} \\ P_1 = 250 \text{ kPa} \end{array} \right\} \nu_1 \cong \nu_f @ 25^\circ\text{C} = 0.001003 \text{ m}^3/\text{kg}$$

$$\nu_1 = m \nu_1 = (50 \text{ kg})(0.001003 \text{ m}^3/\text{kg}) = 0.05 \text{ m}^3$$

$$\nu_2 = 0.2 \text{ m}^3$$

$$\nu_3 = \nu_2 + x_{23}A_p = (0.2 \text{ m}^3) + (0.2 \text{ m})(0.1 \text{ m}^2) = 0.22 \text{ m}^3$$

$$\nu_3 = \frac{\nu_3}{m} = \frac{0.22 \text{ m}^3}{50 \text{ kg}} = 0.0044 \text{ m}^3/\text{kg}$$

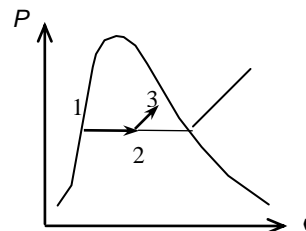

At 450 kPa, $\nu_f = 0.001088 \text{ m}^3/\text{kg}$ and $\nu_g = 0.41392 \text{ m}^3/\text{kg}$. Noting that $\nu_f < \nu_3 < \nu_g$, the final state is a saturated mixture and thus the final temperature is

$$T_3 = T_{\text{sat}@450 \text{ kPa}} = \mathbf{147.9^\circ\text{C}}$$

(b) The pressure remains constant during process 1-2 and changes linearly (a straight line) during process 2-3. Then the boundary work during this process is simply the total area under the process curve,

$$\begin{aligned} W_{b,\text{out}} &= \text{Area} = P_1(\nu_2 - \nu_1) + \frac{P_2 + P_3}{2}(\nu_3 - \nu_2) \\ &= \left((250 \text{ kPa})(0.2 - 0.05) \text{ m}^3 + \frac{(250 + 450) \text{ kPa}}{2} (0.22 - 0.2) \text{ m}^3 \right) \left(\frac{1 \text{ kJ}}{1 \text{ kPa} \cdot \text{m}^3} \right) \\ &= \mathbf{44.5 \text{ kJ}} \end{aligned}$$

Discussion The positive sign indicates that work is done by the system (work output).



4-25 Problem 4-24 is reconsidered. The effect of the spring constant on the final pressure in the cylinder and the boundary work done as the spring constant varies from 50 kN/m to 500 kN/m is to be investigated. The final pressure and the boundary work are to be plotted against the spring constant.

Analysis The problem is solved using EES, and the solution is given below.

$P[3]=P[2]+(\text{Spring_const})\cdot(V[3]-V[2])$ "P[3] is a linear function of V[3]"
 "where $\text{Spring_const} = k/A^2$, the actual spring constant divided by the piston face area squared"

"Input Data"

$P[1]=150$ [kPa]
 $m=50$ [kg]
 $T[1]=25$ [C]
 $P[2]=P[1]$
 $V[2]=0.2$ [m³]
 $A=0.1$ [m²]
 $k=100$ [kN/m]
 $\text{DELTA}x=20$ [cm]
 $\text{Spring_const}=k/A^2$ "[kN/m⁵]"
 $V[1]=m\cdot\text{spvol}[1]$
 $\text{spvol}[1]=\text{volume}(\text{Steam_iapws},P=P[1],T=T[1])$

$V[2]=m\cdot\text{spvol}[2]$
 $V[3]=V[2]+A\cdot\text{DELTA}x\cdot\text{convert}(\text{cm},m)$
 $V[3]=m\cdot\text{spvol}[3]$

"The temperature at state 2 is:"

$T[2]=\text{temperature}(\text{Steam_iapws},P=P[2],v=\text{spvol}[2])$

"The temperature at state 3 is:"

$T[3]=\text{temperature}(\text{Steam_iapws},P=P[3],v=\text{spvol}[3])$

$W_{\text{net_other}} = 0$

$W_{\text{out}}=W_{\text{net_other}} + W_{b12}+W_{b23}$

$W_{b12}=P[1]\cdot(V[2]-V[1])$

" $W_{b23} = \text{integral of } P[3]\cdot dV[3]$ for $\text{Deltax} = 20$ cm and is given by:"

$W_{b23}=P[2]\cdot(V[3]-V[2])+\text{Spring_const}/2\cdot(V[3]-V[2])^2$

k [kN/m]	P_3 [kPa]	W_{out} [kJ]
50	350	43.46
100	450	44.46
150	550	45.46
200	650	46.46
250	750	47.46
300	850	48.46
350	950	49.46
400	1050	50.46
450	1150	51.46
500	1250	52.46

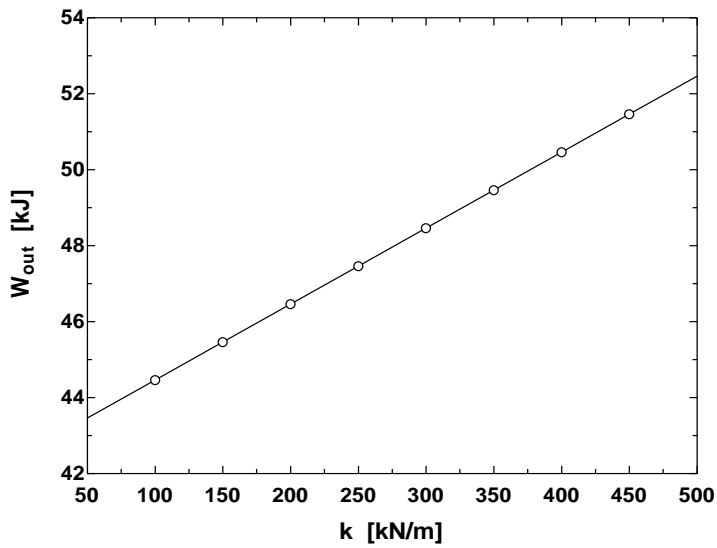
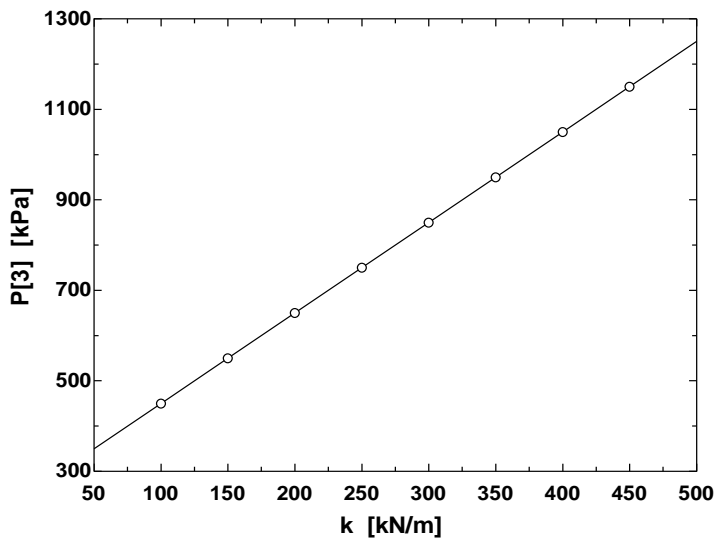
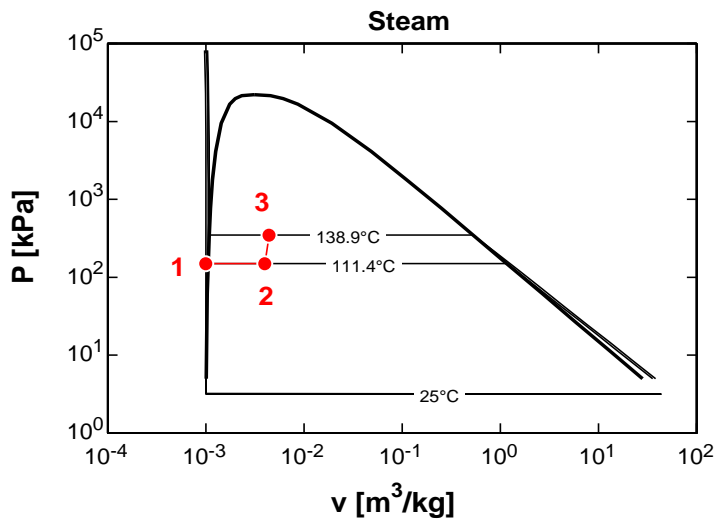

Closed System Energy Analysis

4-26E The table is to be completed using conservation of energy principle for a closed system.

Analysis The energy balance for a closed system can be expressed as

$$\underbrace{E_{\text{in}} - E_{\text{out}}}_{\substack{\text{Net energy transfer} \\ \text{by heat, work, and mass}}} = \underbrace{\Delta E_{\text{system}}}_{\substack{\text{Change in internal, kinetic,} \\ \text{potential, etc. energies}}}$$

$$Q_{\text{in}} - W_{\text{out}} = E_2 - E_1 = m(e_2 - e_1)$$

Application of this equation gives the following completed table:

Q_{in} (Btu)	W_{out} (Btu)	E_1 (Btu)	E_2 (Btu)	m (lbm)	$e_2 - e_1$ (Btu/lbm)
350	510	1020	860	3	-53.3
350	130	550	770	5	44.0
560	260	600	900	2	150
-500	0	1400	900	7	-71.4
-650	-50	1000	400	3	-200

4-27E The heat transfer during a process that a closed system undergoes without any internal energy change is to be determined.

Assumptions 1 The system is stationary and thus the kinetic and potential energy changes are zero. **2** The compression or expansion process is quasi-equilibrium.

Analysis The energy balance for this stationary closed system can be expressed as

$$\underbrace{E_{\text{in}} - E_{\text{out}}}_{\substack{\text{Net energy transfer} \\ \text{by heat, work, and mass}}} = \underbrace{\Delta E_{\text{system}}}_{\substack{\text{Change in internal, kinetic,} \\ \text{potential, etc. energies}}}$$

$$Q_{\text{in}} - W_{\text{out}} = \Delta U = 0 \quad (\text{since KE} = \text{PE} = 0)$$

$$Q_{\text{in}} = W_{\text{out}}$$

Then,

$$Q_{\text{in}} = 1.1 \times 10^6 \text{ lbf} \cdot \text{ft} \left(\frac{1 \text{ Btu}}{778.17 \text{ lbf} \cdot \text{ft}} \right) = \mathbf{1414 \text{ Btu}}$$

4-28 Motor oil is contained in a rigid container that is equipped with a stirring device. The rate of specific energy increase is to be determined.

Analysis This is a closed system since no mass enters or leaves. The energy balance for closed system can be expressed as

$$\underbrace{E_{\text{in}} - E_{\text{out}}}_{\substack{\text{Net energy transfer} \\ \text{by heat, work, and mass}}} = \underbrace{\Delta E_{\text{system}}}_{\substack{\text{Change in internal, kinetic,} \\ \text{potential, etc. energies}}}$$

$$\dot{Q}_{\text{in}} + \dot{W}_{\text{sh, in}} = \Delta \dot{E}$$

Then, $\Delta \dot{E} = \dot{Q}_{\text{in}} + \dot{W}_{\text{sh, in}} = 1 + 1.5 = 2.5 \text{ W}$

Dividing this by the mass in the system gives

$$\Delta \dot{e} = \frac{\Delta \dot{E}}{m} = \frac{2.5 \text{ J/s}}{2.5 \text{ kg}} = \mathbf{1.0 \text{ J/kg} \cdot \text{s}}$$

4-29 A rigid tank is initially filled with superheated R-134a. Heat is transferred to the tank until the pressure inside rises to a specified value. The mass of the refrigerant and the amount of heat transfer are to be determined, and the process is to be shown on a P - ν diagram.

Assumptions **1** The tank is stationary and thus the kinetic and potential energy changes are zero. **2** There are no work interactions.

Analysis (a) We take the tank as the system. This is a closed system since no mass enters or leaves. Noting that the volume of the system is constant and thus there is no boundary work, the energy balance for this stationary closed system can be expressed as

$$\underbrace{E_{\text{in}} - E_{\text{out}}}_{\substack{\text{Net energy transfer} \\ \text{by heat, work, and mass}}} = \underbrace{\Delta E_{\text{system}}}_{\substack{\text{Change in internal, kinetic,} \\ \text{potential, etc. energies}}}$$

$$Q_{\text{in}} = \Delta U = m(u_2 - u_1) \quad (\text{since } W = \text{KE} = \text{PE} = 0)$$

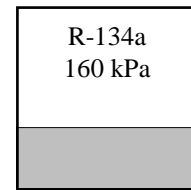

Using data from the refrigerant tables (Tables A-11 through A-13), the properties of R-134a are determined to be

$$\left. \begin{array}{l} P_1 = 160 \text{ kPa} \\ x_1 = 0.4 \end{array} \right\} \begin{array}{l} \nu_f = 0.0007435, \quad \nu_g = 0.12355 \text{ m}^3/\text{kg} \\ u_f = 31.06, \quad u_{fg} = 190.31 \text{ kJ/kg} \end{array}$$

$$\nu_1 = \nu_f + x_1 \nu_{fg} = 0.0007435 + 0.4(0.12355 - 0.0007435) = 0.04987 \text{ m}^3/\text{kg}$$

$$u_1 = u_f + x_1 u_{fg} = 31.06 + 0.4(190.31) = 107.19 \text{ kJ/kg}$$

$$\left. \begin{array}{l} P_2 = 700 \text{ kPa} \\ (\nu_2 = \nu_1) \end{array} \right\} u_2 = 377.23 \text{ kJ/kg (Superheated vapor)}$$

Then the mass of the refrigerant is determined to be

$$m = \frac{\nu_1}{\nu_1} = \frac{0.5 \text{ m}^3}{0.04987 \text{ m}^3/\text{kg}} = \mathbf{10.03 \text{ kg}}$$

(b) Then the heat transfer to the tank becomes

$$\begin{aligned} Q_{\text{in}} &= m(u_2 - u_1) \\ &= (10.03 \text{ kg})(377.23 - 107.19) \text{ kJ/kg} \\ &= \mathbf{2708 \text{ kJ}} \end{aligned}$$

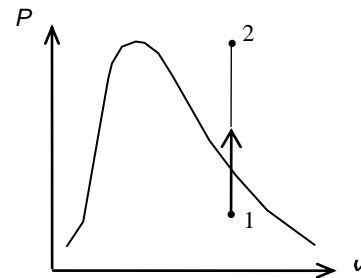

4-30E A rigid tank is initially filled with saturated R-134a vapor. Heat is transferred from the refrigerant until the pressure inside drops to a specified value. The final temperature, the mass of the refrigerant that has condensed, and the amount of heat transfer are to be determined. Also, the process is to be shown on a P - ν diagram.

Assumptions 1 The tank is stationary and thus the kinetic and potential energy changes are zero. **2** There are no work interactions.

Analysis (a) We take the tank as the system. This is a closed system since no mass enters or leaves. Noting that the volume of the system is constant and thus there is no boundary work, the energy balance for this stationary closed system can be expressed as

$$\underbrace{E_{\text{in}} - E_{\text{out}}}_{\substack{\text{Net energy transfer} \\ \text{by heat, work, and mass}}} = \underbrace{\Delta E_{\text{system}}}_{\substack{\text{Change in internal, kinetic,} \\ \text{potential, etc. energies}}}$$

$$-Q_{\text{out}} = \Delta U = m(u_2 - u_1) \quad (\text{since } W = \text{KE} = \text{PE} = 0)$$

$$Q_{\text{out}} = m(u_1 - u_2)$$

Using data from the refrigerant tables (Tables A-11E through A-13E), the properties of R-134a are determined to be

$$P_1 = 160 \text{ psia} \left\{ \begin{array}{l} \nu_1 = \nu_{g@160\text{psia}} = 0.29339 \text{ ft}^3/\text{lbm} \\ \text{sat. vapor} \quad \nu_1 = \nu_{g@160\text{psia}} = 108.51 \text{ Btu/lbm} \end{array} \right.$$

$$P_2 = 50 \text{ psia} \left\{ \begin{array}{l} \nu_f = 0.01252, \quad \nu_g = 0.94909 \text{ ft}^3/\text{lbm} \\ (\nu_2 = \nu_1) \quad \nu_f = 24.824, \quad u_{fg} = 75.228 \text{ Btu/lbm} \end{array} \right.$$

R-134a
160 psia
Sat. vapor

The final state is saturated mixture. Thus,

$$T_2 = T_{\text{sat}@50\text{psia}} = \mathbf{40.23^\circ\text{F}}$$

(b) The total mass and the amount of refrigerant that has condensed are

$$m = \frac{\nu_1}{\nu_1} = \frac{20 \text{ ft}^3}{0.29339 \text{ ft}^3/\text{lbm}} = 68.17 \text{ lbm}$$

$$x_2 = \frac{\nu_2 - \nu_f}{\nu_{fg}} = \frac{0.29339 - 0.01252}{0.94909 - 0.01252} = 0.2999$$

$$m_f = (1 - x_2)m = (1 - 0.2999)(68.17 \text{ lbm}) = \mathbf{47.73 \text{ lbm}}$$

Also,

$$u_2 = u_f + x_2 u_{fg} = 24.824 + 0.2999(75.228) = 47.38 \text{ Btu/lbm}$$

(c) Substituting,

$$Q_{\text{out}} = m(u_1 - u_2)$$

$$= (68.17 \text{ lbm})(108.51 - 47.38) \text{ Btu/lbm}$$

$$= \mathbf{4167 \text{ Btu}}$$

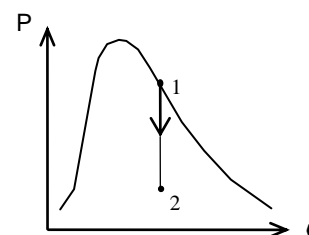

4-31 Water contained in a rigid vessel is heated. The heat transfer is to be determined.

Assumptions **1** The system is stationary and thus the kinetic and potential energy changes are zero. **2** There are no work interactions involved **3** The thermal energy stored in the vessel itself is negligible.

Analysis We take water as the system. This is a closed system since no mass enters or leaves. The energy balance for this stationary closed system can be expressed as

$$\underbrace{E_{\text{in}} - E_{\text{out}}}_{\text{Net energy transfer by heat, work, and mass}} = \underbrace{\Delta E_{\text{system}}}_{\text{Change in internal, kinetic, potential, etc. energies}}$$

$$Q_{\text{in}} = \Delta U = m(u_2 - u_1) \quad (\text{since KE} = \text{PE} = 0)$$

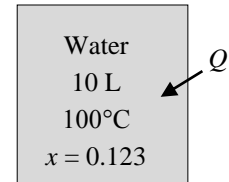

The properties at the initial and final states are (Table A-4)

$$\left. \begin{array}{l} T_1 = 100^\circ\text{C} \\ x_1 = 0.123 \end{array} \right\} \begin{array}{l} v_1 = v_f + x v_{fg} = 0.001043 + (0.123)(1.6720 - 0.001043) = 0.2066 \text{ m}^3 / \text{kg} \\ u_1 = u_f + x u_{fg} = 419.06 + (0.123)(2087.0) = 675.76 \text{ kJ/kg} \end{array}$$

$$\left. \begin{array}{l} T_2 = 150^\circ\text{C} \\ v_2 = v_1 = 0.2066 \text{ m}^3 / \text{kg} \end{array} \right\} \begin{array}{l} x_2 = \frac{v_2 - v_f}{v_{fg}} = \frac{0.2066 - 0.001091}{0.39248 - 0.001091} = 0.5250 \\ u_2 = u_f + x_2 u_{fg} \\ = 631.66 + (0.5250)(1927.4) = 1643.5 \text{ kJ/kg} \end{array}$$

The mass in the system is

$$m = \frac{V_1}{v_1} = \frac{0.100 \text{ m}^3}{0.2066 \text{ m}^3 / \text{kg}} = 0.04841 \text{ kg}$$

Substituting,

$$Q_{\text{in}} = m(u_2 - u_1) = (0.04841 \text{ kg})(1643.5 - 675.76) \text{ kJ/kg} = \mathbf{46.9 \text{ kJ}}$$

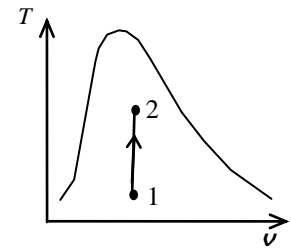

4-32 Saturated vapor water is cooled at constant temperature (and pressure) to a saturated liquid. The heat rejected is to be determined.

Assumptions 1 The cylinder is stationary and thus the kinetic and potential energy changes are zero. **2** There are no work interactions involved other than the boundary work. **3** The thermal energy stored in the cylinder itself is negligible. **4** The compression or expansion process is quasi-equilibrium.

Analysis We take the contents of the cylinder as the system. This is a closed system since no mass enters or leaves. The energy balance for this stationary closed system can be expressed as

$$\underbrace{E_{\text{in}} - E_{\text{out}}}_{\substack{\text{Net energy transfer} \\ \text{by heat, work, and mass}}} = \underbrace{\Delta E_{\text{system}}}_{\substack{\text{Change in internal, kinetic,} \\ \text{potential, etc. energies}}}$$

$$-Q_{\text{out}} - W_{b,\text{out}} = \Delta U = m(u_2 - u_1) \quad (\text{since KE} = \text{PE} = 0)$$

$$-Q_{\text{out}} = W_{b,\text{out}} + m(u_2 - u_1)$$

$$-Q_{\text{out}} = m(h_2 - h_1)$$

$$Q_{\text{out}} = m(h_1 - h_2)$$

$$q_{\text{out}} = h_1 - h_2$$

since $\Delta U + W_b = \Delta H$ during a constant pressure quasi-equilibrium process. Since water changes from saturated liquid to saturated vapor, we have

$$q_{\text{out}} = h_g - h_f = h_{fg@400\text{kPa}} = \mathbf{2133.4\text{kJ/kg}} \quad (\text{Table A-5})$$

Note that the temperature also remains constant during the process and it is the saturation temperature at 400 kPa, which is 143.6°C.

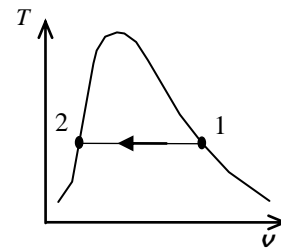
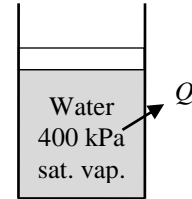

4-33 A cylinder is initially filled with steam at a specified state. The steam is cooled at constant pressure. The mass of the steam, the final temperature, and the amount of heat transfer are to be determined, and the process is to be shown on a T - ν diagram.

Assumptions **1** The cylinder is stationary and thus the kinetic and potential energy changes are zero. **2** There are no work interactions involved other than the boundary work. **3** The thermal energy stored in the cylinder itself is negligible. **4** The compression or expansion process is quasi-equilibrium.

Analysis We take the contents of the cylinder as the system. This is a closed system since no mass enters or leaves. The energy balance for this stationary closed system can be expressed as

$$\underbrace{E_{\text{in}} - E_{\text{out}}}_{\substack{\text{Net energy transfer} \\ \text{by heat, work, and mass}}} = \underbrace{\Delta E_{\text{system}}}_{\substack{\text{Change in internal, kinetic,} \\ \text{potential, etc. energies}}}$$

$$-Q_{\text{out}} - W_{b,\text{out}} = \Delta U = m(u_2 - u_1) \quad (\text{since KE} = \text{PE} = 0)$$

$$-Q_{\text{out}} = m(h_2 - h_1)$$

since $\Delta U + W_b = \Delta H$ during a constant pressure quasi-equilibrium process. The properties of water are (Tables A-4 through A-6)

$$\left. \begin{array}{l} P_1 = 1 \text{ MPa} \\ T_2 = 450^\circ\text{C} \end{array} \right\} \begin{array}{l} \nu_1 = 0.33045 \text{ m}^3/\text{kg} \\ h_1 = 3371.3 \text{ kJ/kg} \end{array}$$

$$m = \frac{V_1}{\nu_1} = \frac{2.5 \text{ m}^3}{0.33045 \text{ m}^3/\text{kg}} = \mathbf{7.565 \text{ kg}}$$

(b) The final temperature is determined from

$$\left. \begin{array}{l} P_2 = 1 \text{ MPa} \\ \text{sat. vapor} \end{array} \right\} \begin{array}{l} T_2 = T_{\text{sat}@1 \text{ MPa}} = \mathbf{179.9^\circ\text{C}} \\ h_2 = h_{g@1 \text{ MPa}} = 2777.1 \text{ kJ/kg} \end{array}$$

(c) Substituting, the energy balance gives

$$Q_{\text{out}} = - (7.565 \text{ kg})(2777.1 - 3371.3) \text{ kJ/kg} = \mathbf{4495 \text{ kJ}}$$

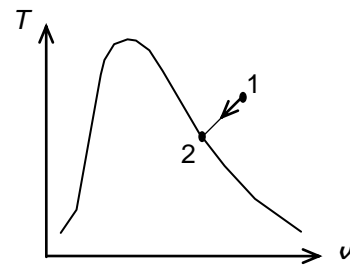
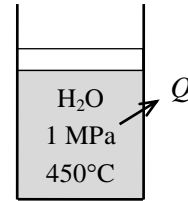

4-34 A cylinder is initially filled with saturated liquid water at a specified pressure. The water is heated electrically as it is stirred by a paddle-wheel at constant pressure. The voltage of the current source is to be determined, and the process is to be shown on a P - ν diagram.

Assumptions 1 The cylinder is stationary and thus the kinetic and potential energy changes are zero. **2** The cylinder is well-insulated and thus heat transfer is negligible. **3** The thermal energy stored in the cylinder itself is negligible. **4** The compression or expansion process is quasi-equilibrium.

Analysis We take the contents of the cylinder as the system. This is a closed system since no mass enters or leaves. The energy balance for this stationary closed system can be expressed as

$$\underbrace{E_{in} - E_{out}}_{\substack{\text{Net energy transfer} \\ \text{by heat, work, and mass}}} = \underbrace{\Delta E_{system}}_{\substack{\text{Change in internal, kinetic,} \\ \text{potential, etc. energies}}}$$

$$W_{e,in} + W_{pw,in} - W_{b,out} = \Delta U \quad (\text{since } Q = KE = PE = 0)$$

$$W_{e,in} + W_{pw,in} = m(h_2 - h_1)$$

$$(VI\Delta t) + W_{pw,in} = m(h_2 - h_1)$$

since $\Delta U + W_b = \Delta H$ during a constant pressure quasi-equilibrium process. The properties of water are (Tables A-4 through A-6)

$$\left. \begin{array}{l} P_1 = 175 \text{ kPa} \\ \text{sat. liquid} \end{array} \right\} \begin{array}{l} h_1 = h_{f@175 \text{ kPa}} = 487.01 \text{ kJ/kg} \\ \nu_1 = \nu_{f@175 \text{ kPa}} = 0.001057 \text{ m}^3/\text{kg} \end{array}$$

$$\left. \begin{array}{l} P_2 = 175 \text{ kPa} \\ x_2 = 0.5 \end{array} \right\} \begin{array}{l} h_2 = h_f + x_2 h_{fg} = 487.01 + (0.5 \times 2213.1) = 1593.6 \text{ kJ/kg} \end{array}$$

$$m = \frac{\nu_1}{\nu_1} = \frac{0.005 \text{ m}^3}{0.001057 \text{ m}^3/\text{kg}} = 4.731 \text{ kg}$$

Substituting,

$$VI\Delta t + (400 \text{ kJ}) = (4.731 \text{ kg})(1593.6 - 487.01) \text{ kJ/kg}$$

$$VI\Delta t = 4835 \text{ kJ}$$

$$V = \frac{4835 \text{ kJ}}{(8 \text{ A})(45 \times 60 \text{ s})} \left(\frac{1000 \text{ VA}}{1 \text{ kJ/s}} \right) = \mathbf{223.9 \text{ V}}$$

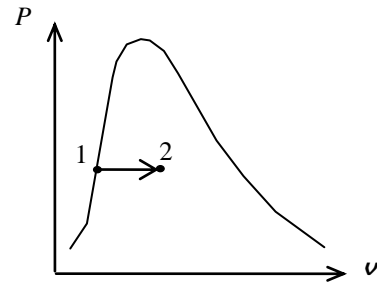
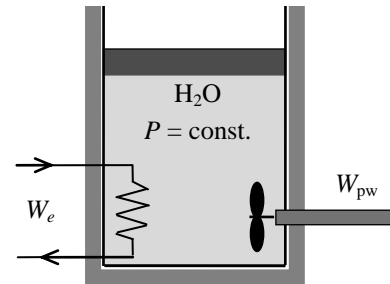



4-35 A cylinder equipped with an external spring is initially filled with steam at a specified state. Heat is transferred to the steam, and both the temperature and pressure rise. The final temperature, the boundary work done by the steam, and the amount of heat transfer are to be determined, and the process is to be shown on a P - v diagram.

Assumptions **1** The cylinder is stationary and thus the kinetic and potential energy changes are zero. **2** The thermal energy stored in the cylinder itself is negligible. **3** The compression or expansion process is quasi-equilibrium. **4** The spring is a linear spring.

Analysis We take the contents of the cylinder as the system. This is a closed system since no mass enters or leaves. Noting that the spring is not part of the system (it is external), the energy balance for this stationary closed system can be expressed as

$$\underbrace{E_{in} - E_{out}}_{\text{Net energy transfer by heat, work, and mass}} = \underbrace{\Delta E_{\text{system}}}_{\text{Change in internal, kinetic, potential, etc. energies}}$$

$$Q_{in} - W_{b,out} = \Delta U = m(u_2 - u_1) \quad (\text{since KE} = \text{PE} = 0)$$

$$Q_{in} = m(u_2 - u_1) + W_{b,out}$$

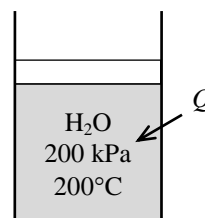

The properties of steam are (Tables A-4 through A-6)

$$\left. \begin{array}{l} P_1 = 200 \text{ kPa} \\ T_1 = 200^\circ\text{C} \end{array} \right\} \begin{array}{l} v_1 = 1.08049 \text{ m}^3/\text{kg} \\ u_1 = 2654.6 \text{ kJ/kg} \end{array}$$

$$m = \frac{V_1}{v_1} = \frac{0.4 \text{ m}^3}{1.08049 \text{ m}^3/\text{kg}} = 0.3702 \text{ kg}$$

$$v_2 = \frac{V_2}{m} = \frac{0.6 \text{ m}^3}{0.3702 \text{ kg}} = 1.6207 \text{ m}^3/\text{kg}$$

$$\left. \begin{array}{l} P_2 = 250 \text{ kPa} \\ v_2 = 1.6207 \text{ m}^3/\text{kg} \end{array} \right\} \begin{array}{l} T_2 = \mathbf{606^\circ\text{C}} \\ u_2 = 3312.0 \text{ kJ/kg} \end{array}$$

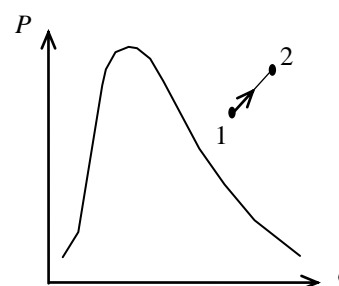

(b) The pressure of the gas changes linearly with volume, and thus the process curve on a P - V diagram will be a straight line. The boundary work during this process is simply the area under the process curve, which is a trapezoidal. Thus,

$$W_b = \text{Area} = \frac{P_1 + P_2}{2} (v_2 - v_1) = \frac{(200 + 250) \text{ kPa}}{2} (0.6 - 0.4) \text{ m}^3 \left(\frac{1 \text{ kJ}}{1 \text{ kPa} \cdot \text{m}^3} \right) = \mathbf{45 \text{ kJ}}$$

(c) From the energy balance we have

$$Q_{in} = (0.3702 \text{ kg})(3312.0 - 2654.6) \text{ kJ/kg} + 45 \text{ kJ} = \mathbf{288 \text{ kJ}}$$



4-36 Problem 4-35 is reconsidered. The effect of the initial temperature of steam on the final temperature, the work done, and the total heat transfer as the initial temperature varies from 150°C to 250°C is to be investigated. The final results are to be plotted against the initial temperature.

Analysis The problem is solved using EES, and the solution is given below.

"The process is given by:"

" $P[2]=P[1]+k*x*A/A$, and as the spring moves 'x' amount, the volume changes by $V[2]-V[1]$."

$P[2]=P[1]+(Spring_const)*(V[2] - V[1])$ "P[2] is a linear function of V[2]"

"where $Spring_const = k/A$, the actual spring constant divided by the piston face area"

"Conservation of mass for the closed system is:"

$m[2]=m[1]$

"The conservation of energy for the closed system is"

" $E_{in} - E_{out} = \Delta E$, neglect ΔKE and ΔPE for the system"

$Q_{in} - W_{out} = m[1]*(u[2]-u[1])$

$\Delta U = m[1]*(u[2]-u[1])$

"Input Data"

$P[1]=200$ [kPa]

$V[1]=0.4$ [m³]

$T[1]=200$ [C]

$P[2]=250$ [kPa]

$V[2]=0.6$ [m³]

Fluid\$='Steam_IAPWS'

$m[1]=V[1]/spvol[1]$

$spvol[1]=volume(Fluid$, T=T[1], P=P[1])$

$u[1]=intenergy(Fluid$, T=T[1], P=P[1])$

$spvol[2]=V[2]/m[2]$

"The final temperature is:"

$T[2]=temperature(Fluid$, P=P[2], v=spvol[2])$

$u[2]=intenergy(Fluid$, P=P[2], T=T[2])$

$W_{net_other} = 0$

$W_{out}=W_{net_other} + W_b$

" $W_b = \int P[2]*dV[2]$ for $0.5 < V[2] < 0.6$ and is given by:"

$W_b = P[1]*(V[2]-V[1]) + Spring_const/2*(V[2]-V[1])^2$

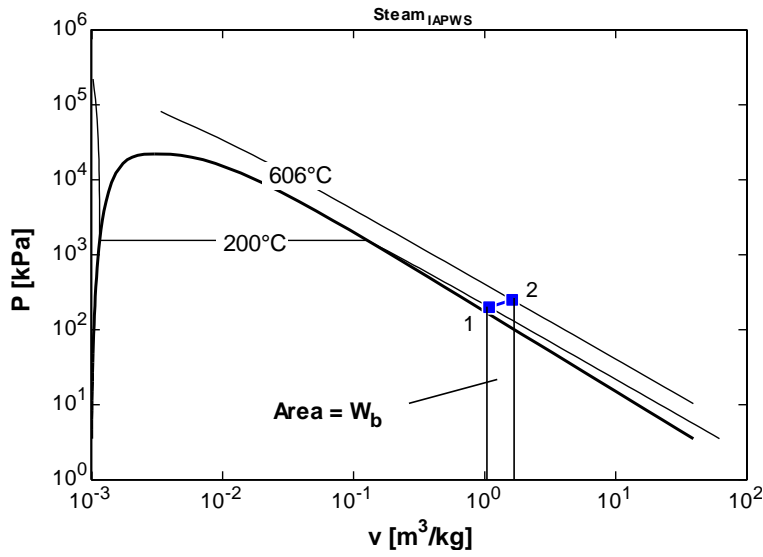

T_1 [C]	Q_{in} [kJ]	T_2 [C]	W_{out} [kJ]
150	281.5	508.2	45
160	282.8	527.9	45
170	284.2	547.5	45
180	285.5	567	45
190	286.9	586.4	45
200	288.3	605.8	45
210	289.8	625	45
220	291.2	644.3	45
230	292.7	663.4	45
240	294.2	682.6	45
250	295.7	701.7	45

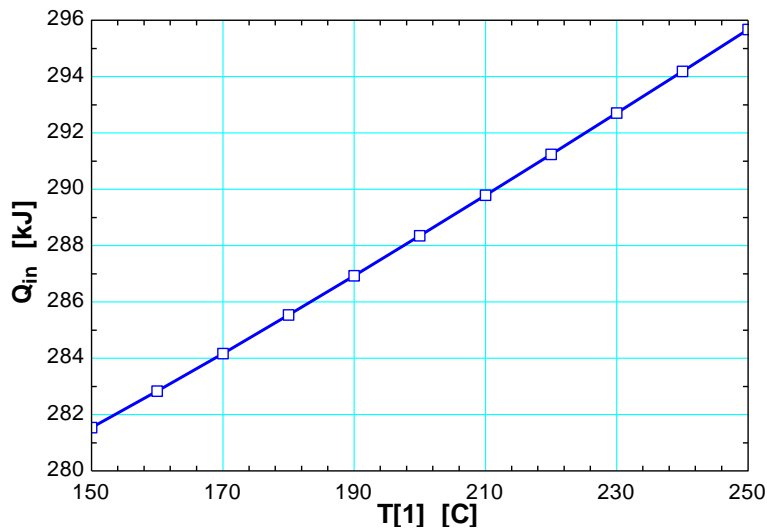
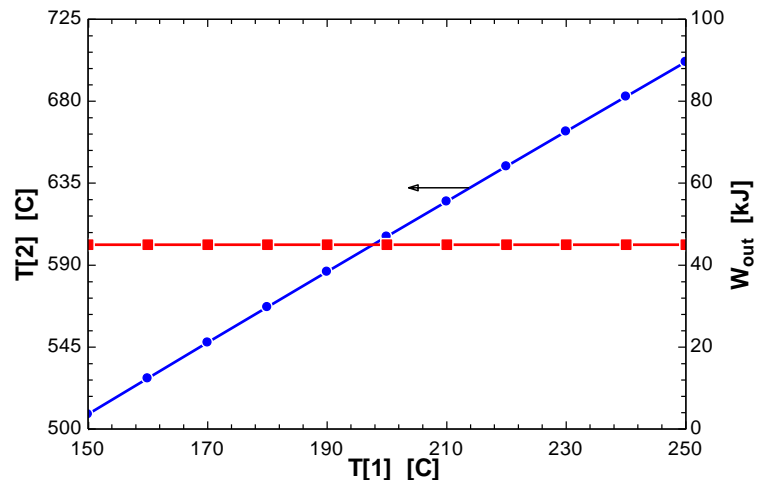

4-37 A cylinder equipped with a set of stops for the piston to rest on is initially filled with saturated water vapor at a specified pressure. Heat is transferred to water until the volume doubles. The final temperature, the boundary work done by the steam, and the amount of heat transfer are to be determined, and the process is to be shown on a P - v diagram.

Assumptions 1 The cylinder is stationary and thus the kinetic and potential energy changes are zero. **2** There are no work interactions involved other than the boundary work. **3** The thermal energy stored in the cylinder itself is negligible. **4** The compression or expansion process is quasi-equilibrium.

Analysis We take the contents of the cylinder as the system. This is a closed system since no mass enters or leaves. The energy balance for this stationary closed system can be expressed as

$$\underbrace{E_{\text{in}} - E_{\text{out}}}_{\substack{\text{Net energy transfer} \\ \text{by heat, work, and mass}}} = \underbrace{\Delta E_{\text{system}}}_{\substack{\text{Change in internal, kinetic,} \\ \text{potential, etc. energies}}}$$

$$Q_{\text{in}} - W_{b,\text{out}} = \Delta U = m(u_3 - u_1) \quad (\text{since KE} = \text{PE} = 0)$$

$$Q_{\text{in}} = m(u_3 - u_1) + W_{b,\text{out}}$$

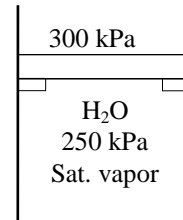

The properties of steam are (Tables A-4 through A-6)

$$P_1 = 250 \text{ kPa} \left\{ \begin{array}{l} v_1 = v_{g@250\text{kPa}} = 0.71873 \text{ m}^3/\text{kg} \\ \text{sat. vapor} \quad u_1 = u_{g@250\text{kPa}} = 2536.8 \text{ kJ/kg} \end{array} \right.$$

$$m = \frac{V_1}{v_1} = \frac{0.8 \text{ m}^3}{0.71873 \text{ m}^3/\text{kg}} = 1.113 \text{ kg}$$

$$v_3 = \frac{V_3}{m} = \frac{1.6 \text{ m}^3}{1.113 \text{ kg}} = 1.4375 \text{ m}^3/\text{kg}$$

$$P_3 = 300 \text{ kPa} \left\{ \begin{array}{l} T_3 = \mathbf{662^\circ\text{C}} \\ v_3 = 1.4375 \text{ m}^3/\text{kg} \quad u_3 = 3411.4 \text{ kJ/kg} \end{array} \right.$$

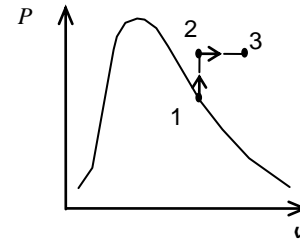

(b) The work done during process 1-2 is zero (since $v = \text{const}$) and the work done during the constant pressure process 2-3 is

$$W_{b,\text{out}} = \int_2^3 P dV = P(V_3 - V_2) = (300 \text{ kPa})(1.6 - 0.8) \text{ m}^3 \left(\frac{1 \text{ kJ}}{1 \text{ kPa} \cdot \text{m}^3} \right) = \mathbf{240 \text{ kJ}}$$

(c) Heat transfer is determined from the energy balance,

$$Q_{\text{in}} = m(u_3 - u_1) + W_{b,\text{out}}$$

$$= (1.113 \text{ kg})(3411.4 - 2536.8) \text{ kJ/kg} + 240 \text{ kJ} = \mathbf{1213 \text{ kJ}}$$

4-38 A room is heated by an electrical radiator containing heating oil. Heat is lost from the room. The time period during which the heater is on is to be determined.

Assumptions 1 Air is an ideal gas since it is at a high temperature and low pressure relative to its critical point values of -141°C and 3.77 MPa . **2** The kinetic and potential energy changes are negligible, $\Delta ke \cong \Delta pe \cong 0$. **3** Constant specific heats at room temperature can be used for air. This assumption results in negligible error in heating and air-conditioning applications. **4** The local atmospheric pressure is 100 kPa . **5** The room is air-tight so that no air leaks in and out during the process.

Properties The gas constant of air is $R = 0.287\text{ kPa}\cdot\text{m}^3/\text{kg}\cdot\text{K}$ (Table A-1). Also, $c_v = 0.718\text{ kJ}/\text{kg}\cdot\text{K}$ for air at room temperature (Table A-2). Oil properties are given to be $\rho = 950\text{ kg}/\text{m}^3$ and $c_p = 2.2\text{ kJ}/\text{kg}\cdot^{\circ}\text{C}$.

Analysis We take the air in the room and the oil in the radiator to be the system. This is a closed system since no mass crosses the system boundary. The energy balance for this stationary constant-volume closed system can be expressed as

$$\underbrace{E_{\text{in}} - E_{\text{out}}}_{\substack{\text{Net energy transfer} \\ \text{by heat, work, and mass}}} = \underbrace{\Delta E_{\text{system}}}_{\substack{\text{Change in internal, kinetic,} \\ \text{potential, etc. energies}}}$$

$$(\dot{W}_{\text{in}} - \dot{Q}_{\text{out}})\Delta t = \Delta U_{\text{air}} + \Delta U_{\text{oil}}$$

$$\cong [mc_v(T_2 - T_1)]_{\text{air}} + [mc_p(T_2 - T_1)]_{\text{oil}} \quad (\text{since KE} = \text{PE} = 0)$$

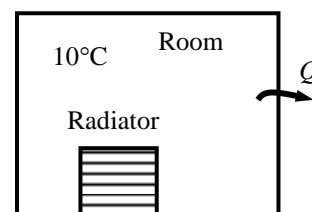

The mass of air and oil are

$$m_{\text{air}} = \frac{P\mathcal{V}_{\text{air}}}{RT_1} = \frac{(100\text{ kPa})(50\text{ m}^3)}{(0.287\text{ kPa}\cdot\text{m}^3/\text{kg}\cdot\text{K})(10 + 273\text{ K})} = 62.32\text{ kg}$$

$$m_{\text{oil}} = \rho_{\text{oil}}\mathcal{V}_{\text{oil}} = (950\text{ kg}/\text{m}^3)(0.040\text{ m}^3) = 38\text{ kg}$$

Substituting,

$$(2.4 - 0.35\text{ kJ}/\text{s})\Delta t = (62.32\text{ kg})(0.718\text{ kJ}/\text{kg}\cdot^{\circ}\text{C})(20 - 10)^{\circ}\text{C} + (38\text{ kg})(2.2\text{ kJ}/\text{kg}\cdot^{\circ}\text{C})(50 - 10)^{\circ}\text{C}$$

$$\longrightarrow \Delta t = \mathbf{1850\text{ s} = 30.8\text{ min}}$$

Discussion In practice, the pressure in the room will remain constant during this process rather than the volume, and some air will leak out as the air expands. As a result, the air in the room will undergo a constant pressure expansion process. Therefore, it is more proper to be conservative and to use ΔH instead of use ΔU in heating and air-conditioning applications.

4-39 A saturated water mixture contained in a spring-loaded piston-cylinder device is heated until the pressure and volume rise to specified values. The heat transfer and the work done are to be determined.

Assumptions 1 The cylinder is stationary and thus the kinetic and potential energy changes are zero. **2** There are no work interactions involved other than the boundary work. **3** The thermal energy stored in the cylinder itself is negligible. **4** The compression or expansion process is quasi-equilibrium.

Analysis We take the contents of the cylinder as the system. This is a closed system since no mass enters or leaves. The energy balance for this stationary closed system can be expressed as

$$\underbrace{E_{\text{in}} - E_{\text{out}}}_{\text{Net energy transfer by heat, work, and mass}} = \underbrace{\Delta E_{\text{system}}}_{\text{Change in internal, kinetic, potential, etc. energies}}$$

$$Q_{\text{in}} - W_{b,\text{out}} = \Delta U = m(u_2 - u_1) \quad (\text{since KE} = \text{PE} = 0)$$

$$Q_{\text{in}} = W_{b,\text{out}} + m(u_2 - u_1)$$

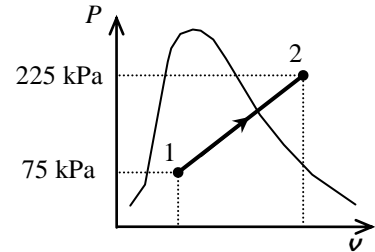

The initial state is saturated mixture at 75 kPa. The specific volume and internal energy at this state are (Table A-5),

$$v_1 = v_f + xv_{fg} = 0.001037 + (0.08)(2.2172 - 0.001037) = 0.1783 \text{ m}^3/\text{kg}$$

$$u_1 = u_f + xu_{fg} = 384.36 + (0.08)(2111.8) = 553.30 \text{ kJ/kg}$$

The mass of water is

$$m = \frac{V_1}{v_1} = \frac{2 \text{ m}^3}{0.1783 \text{ m}^3/\text{kg}} = 11.22 \text{ kg}$$

The final specific volume is

$$v_2 = \frac{V_2}{m} = \frac{5 \text{ m}^3}{11.22 \text{ kg}} = 0.4458 \text{ m}^3/\text{kg}$$

The final state is now fixed. The internal energy at this specific volume and 225 kPa pressure is (Table A-6)

$$u_2 = 1650.4 \text{ kJ/kg}$$

Since this is a linear process, the work done is equal to the area under the process line 1-2:

$$W_{b,\text{out}} = \text{Area} = \frac{P_1 + P_2}{2} (v_2 - v_1) = \frac{(75 + 225) \text{ kPa}}{2} (5 - 2) \text{ m}^3 \left(\frac{1 \text{ kJ}}{1 \text{ kPa} \cdot \text{m}^3} \right) = \mathbf{450 \text{ kJ}}$$

Substituting into energy balance equation gives

$$Q_{\text{in}} = W_{b,\text{out}} + m(u_2 - u_1) = 450 \text{ kJ} + (11.22 \text{ kg})(1650.4 - 553.30) \text{ kJ/kg} = \mathbf{12,750 \text{ kJ}}$$

4-40E Saturated R-134a vapor is condensed at constant pressure to a saturated liquid in a piston-cylinder device. The heat transfer and the work done are to be determined.

Assumptions 1 The cylinder is stationary and thus the kinetic and potential energy changes are zero. **2** There are no work interactions involved other than the boundary work. **3** The thermal energy stored in the cylinder itself is negligible. **4** The compression or expansion process is quasi-equilibrium.

Analysis We take the contents of the cylinder as the system. This is a closed system since no mass enters or leaves. The energy balance for this stationary closed system can be expressed as

$$\underbrace{E_{\text{in}} - E_{\text{out}}}_{\substack{\text{Net energy transfer} \\ \text{by heat, work, and mass}}} = \underbrace{\Delta E_{\text{system}}}_{\substack{\text{Change in internal, kinetic,} \\ \text{potential, etc. energies}}}$$

$$W_{b,\text{in}} - Q_{\text{out}} = \Delta U = m(u_2 - u_1) \quad (\text{since KE} = \text{PE} = 0)$$

$$Q_{\text{out}} = W_{b,\text{in}} - m(u_2 - u_1)$$

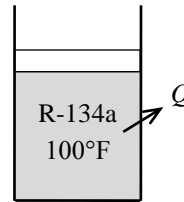

The properties at the initial and final states are (Table A-11E)

$$\left. \begin{array}{l} T_1 = 100^\circ\text{F} \\ x_1 = 1 \end{array} \right\} \begin{array}{l} v_1 = v_g = 0.34074 \text{ ft}^3/\text{lbm} \\ u_1 = u_g = 107.46 \text{ Btu/lbm} \end{array}$$

$$\left. \begin{array}{l} T_2 = 100^\circ\text{F} \\ x_2 = 0 \end{array} \right\} \begin{array}{l} v_2 = v_f = 0.01386 \text{ ft}^3/\text{lbm} \\ u_2 = u_f = 44.774 \text{ Btu/lbm} \end{array}$$

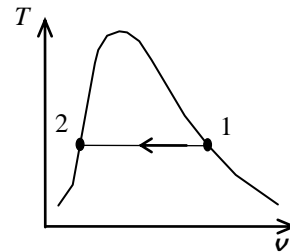

Also from Table A-11E,

$$P_1 = P_2 = 138.93 \text{ psia}$$

$$u_{fg} = 62.690 \text{ Btu/lbm}$$

$$h_{fg} = 71.094 \text{ Btu/lbm}$$

The work done during this process is

$$w_{b,\text{out}} = \int_1^2 P d v = P(v_2 - v_1) = (138.93 \text{ psia})(0.01386 - 0.34074) \text{ ft}^3/\text{lbm} \left(\frac{1 \text{ Btu}}{5.404 \text{ psia} \cdot \text{ft}^3} \right) = -8.404 \text{ Btu/lbm}$$

That is,

$$w_{b,\text{in}} = \mathbf{8.40 \text{ Btu/lbm}}$$

Substituting into energy balance equation gives

$$q_{\text{out}} = w_{b,\text{in}} - (u_2 - u_1) = w_{b,\text{in}} + u_{fg} = 8.40 + 62.690 = \mathbf{71.09 \text{ Btu/lbm}}$$

Discussion The heat transfer may also be determined from

$$-q_{\text{out}} = h_2 - h_1$$

$$q_{\text{out}} = h_{fg} = 71.09 \text{ Btu/lbm}$$

since $\Delta U + W_b = \Delta H$ during a constant pressure quasi-equilibrium process.

4-41 One part of an insulated tank contains compressed liquid while the other side is evacuated. The partition is then removed, and water is allowed to expand into the entire tank. The final temperature and the volume of the tank are to be determined.

Assumptions 1 The tank is stationary and thus the kinetic and potential energy changes are zero. **2** The tank is insulated and thus heat transfer is negligible. **3** There are no work interactions.

Analysis We take the entire contents of the tank as the system. This is a closed system since no mass enters or leaves. Noting that the volume of the system is constant and thus there is no boundary work, the energy balance for this stationary closed system can be expressed as

$$\underbrace{E_{\text{in}} - E_{\text{out}}}_{\substack{\text{Net energy transfer} \\ \text{by heat, work, and mass}}} = \underbrace{\Delta E_{\text{system}}}_{\substack{\text{Change in internal, kinetic,} \\ \text{potential, etc. energies}}}$$

$$0 = \Delta U = m(u_2 - u_1) \quad (\text{since } W = Q = \text{KE} = \text{PE} = 0)$$

$$u_1 = u_2$$

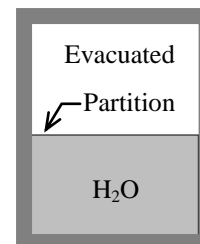

The properties of water are (Tables A-4 through A-6)

$$\left. \begin{array}{l} P_1 = 600 \text{ kPa} \\ T_1 = 60^\circ\text{C} \end{array} \right\} \begin{array}{l} v_1 \cong v_f @ 60^\circ\text{C} = 0.001017 \text{ m}^3/\text{kg} \\ u_1 \cong u_f @ 60^\circ\text{C} = 251.16 \text{ kJ/kg} \end{array}$$

We now assume the final state in the tank is saturated liquid-vapor mixture and determine quality. This assumption will be verified if we get a quality between 0 and 1.

$$\left. \begin{array}{l} P_2 = 10 \text{ kPa} \\ (u_2 = u_1) \end{array} \right\} \begin{array}{l} v_f = 0.001010, \quad v_g = 14.670 \text{ m}^3/\text{kg} \\ u_f = 191.79, \quad u_{fg} = 2245.4 \text{ kJ/kg} \end{array}$$

$$x_2 = \frac{u_2 - u_f}{u_{fg}} = \frac{251.16 - 191.79}{2245.4} = 0.02644$$

Thus,

$$T_2 = T_{\text{sat @ } 10 \text{ kPa}} = \mathbf{45.81^\circ\text{C}}$$

$$v_2 = v_f + x_2 v_{fg} = 0.001010 + [0.02644 \times (14.670 - 0.001010)] = 0.38886 \text{ m}^3/\text{kg}$$

and,

$$V = m v_2 = (2.5 \text{ kg})(0.38886 \text{ m}^3/\text{kg}) = \mathbf{0.972 \text{ m}^3}$$



4-42 Problem 4-41 is reconsidered. The effect of the initial pressure of water on the final temperature in the tank as the initial pressure varies from 100 kPa to 600 kPa is to be investigated. The final temperature is to be plotted against the initial pressure.

Analysis The problem is solved using EES, and the solution is given below.

"Knowns"

$m=2.5$ [kg]
 $\{P[1]=600$ [kPa] $\}$
 $T[1]=60$ [C]
 $P[2]=10$ [kPa]

"Solution"

Fluid\$='Steam_IAPWS'
 "Conservation of Energy for the closed tank:"
 $E_{in}-E_{out}=\Delta E$
 $E_{in}=0$
 $E_{out}=0$
 $\Delta E=m*(u[2]-u[1])$
 $u[1]=\text{INTENERGY}(\text{Fluid}\$,P=P[1],T=T[1])$
 $v[1]=\text{volume}(\text{Fluid}\$,P=P[1],T=T[1])$
 $T[2]=\text{temperature}(\text{Fluid}\$,P=P[2],u=u[2])$
 $T_2=T[2]$
 $v[2]=\text{volume}(\text{Fluid}\$,P=P[2],u=u[2])$
 $V_{total}=m*v[2]$

P_1 [kPa]	T_2 [C]
100	45.79
200	45.79
300	45.79
400	45.79
500	45.79
600	45.79

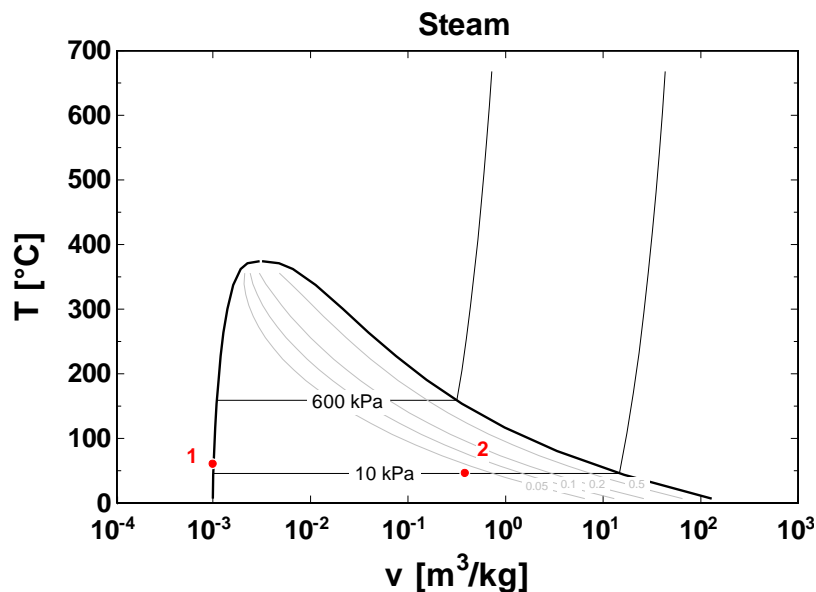
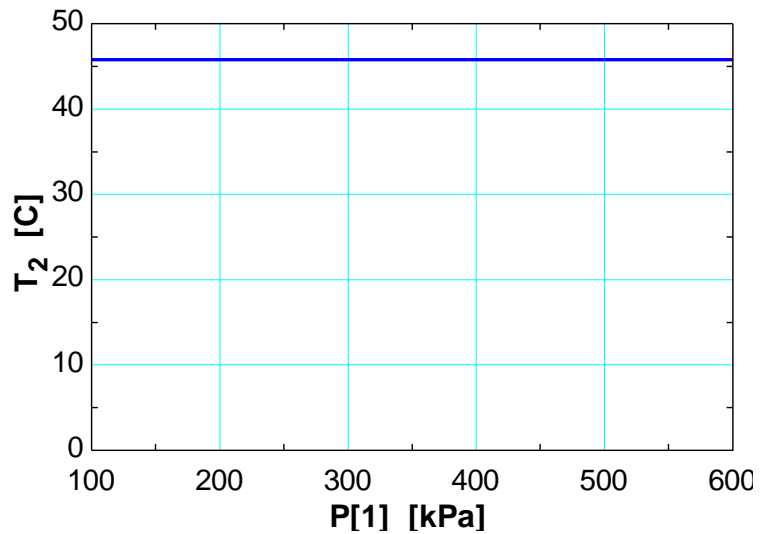

Specific Heats, Δu and Δh of Ideal Gases

4-43C It can be used for any kind of process of an ideal gas.

4-44C It can be used for any kind of process of an ideal gas.

4-45C Very close, but no. Because the heat transfer during this process is $Q = mc_p\Delta T$, and c_p varies with temperature.

4-46C The energy required is $mc_p\Delta T$, which will be the same in both cases. This is because the c_p of an ideal gas does not vary with pressure.

4-47C The energy required is $mc_p\Delta T$, which will be the same in both cases. This is because the c_p of an ideal gas does not vary with volume.

4-48C For the constant pressure case. This is because the heat transfer to an ideal gas is $mc_p\Delta T$ at constant pressure, $mc_v\Delta T$ at constant volume, and c_p is always greater than c_v .

4-49 The desired result is obtained by multiplying the first relation by the molar mass M ,

$$Mc_p = Mc_v + MR$$

or $\bar{c}_p = \bar{c}_v + R_u$

4-50 The enthalpy change of oxygen is to be determined for two cases of specified temperature changes.

Assumptions At specified conditions, oxygen behaves as an ideal gas.

Properties The constant-pressure specific heat of oxygen at room temperature is $c_p = 0.918 \text{ kJ/kg}\cdot\text{K}$ (Table A-2a).

Analysis Using the specific heat at constant pressure,

$$\Delta h = c_p \Delta T = (0.918 \text{ kJ/kg}\cdot\text{K})(250 - 150)\text{K} = \mathbf{91.8 \text{ kJ/kg}}$$

If we use the same room temperature specific heat value, the enthalpy change will be the same for the second case. However, if we consider the variation of specific heat with temperature and use the specific heat values from Table A-2b, we have $c_p = 0.964 \text{ kJ/kg}\cdot\text{K}$ at 200°C ($= 473 \text{ K}$) and $c_p = 0.934 \text{ kJ/kg}\cdot\text{K}$ at 100°C ($\cong 373 \text{ K}$). Then,

$$\Delta h_1 = c_p \Delta T_1 = (0.964 \text{ kJ/kg}\cdot\text{K})(250 - 150)\text{K} = \mathbf{96.4 \text{ kJ/kg}}$$

$$\Delta h_2 = c_p \Delta T_1 = (0.934 \text{ kJ/kg}\cdot\text{K})(100 - 0)\text{K} = \mathbf{93.4 \text{ kJ/kg}}$$

The two results differ from each other by about 3%. The pressure has no influence on the enthalpy of an ideal gas.

4-51E Air is compressed isothermally in a compressor. The change in the specific volume of air is to be determined.

Assumptions At specified conditions, air behaves as an ideal gas.

Properties The gas constant of air is $R = 0.3704 \text{ psia}\cdot\text{ft}^3/\text{lbm}\cdot\text{R}$ (Table A-1E).

Analysis At the compressor inlet, the specific volume is

$$\nu_1 = \frac{RT}{P_1} = \frac{(0.3704 \text{ psia}\cdot\text{ft}^3/\text{lbm}\cdot\text{R})(70 + 460 \text{ R})}{20 \text{ psia}} = 9.816 \text{ ft}^3/\text{lbm}$$

Similarly, at the compressor exit,

$$\nu_2 = \frac{RT}{P_2} = \frac{(0.3704 \text{ psia}\cdot\text{ft}^3/\text{lbm}\cdot\text{R})(70 + 460 \text{ R})}{150 \text{ psia}} = 1.309 \text{ ft}^3/\text{lbm}$$

The change in the specific volume caused by the compressor is

$$\Delta \nu = \nu_2 - \nu_1 = 1.309 - 9.816 = \mathbf{-8.51 \text{ ft}^3/\text{lbm}}$$

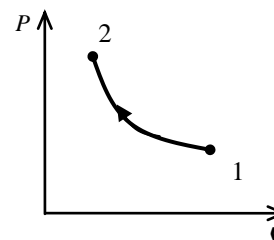

4-52 The total internal energy changes for neon and argon are to be determined for a given temperature change.

Assumptions At specified conditions, neon and argon behave as an ideal gas.

Properties The constant-volume specific heats of neon and argon are $0.6179 \text{ kJ/kg}\cdot\text{K}$ and $0.3122 \text{ kJ/kg}\cdot\text{K}$, respectively (Table A-2a).

Analysis The total internal energy changes are

$$\Delta U_{\text{neon}} = mc_\nu \Delta T = (2 \text{ kg})(0.6179 \text{ kJ/kg}\cdot\text{K})(180 - 20)\text{K} = \mathbf{197.7 \text{ kJ}}$$

$$\Delta U_{\text{argon}} = mc_\nu \Delta T = (2 \text{ kg})(0.3122 \text{ kJ/kg}\cdot\text{K})(180 - 20)\text{K} = \mathbf{99.9 \text{ kJ}}$$

4-53 The enthalpy changes for neon and argon are to be determined for a given temperature change.

Assumptions At specified conditions, neon and argon behave as an ideal gas.

Properties The constant-pressure specific heats of argon and neon are 0.5203 kJ/kg·K and 1.0299 kJ/kg·K, respectively (Table A-2a).

Analysis The enthalpy changes are

$$\Delta h_{\text{argon}} = c_p \Delta T = (0.5203 \text{ kJ/kg} \cdot \text{K})(25 - 75)\text{K} = \mathbf{-26.0 \text{ kJ/kg}}$$

$$\Delta h_{\text{neon}} = c_p \Delta T = (1.0299 \text{ kJ/kg} \cdot \text{K})(25 - 75)\text{K} = \mathbf{-51.5 \text{ kJ/kg}}$$

4-54 The internal energy change of hydrogen gas during a heating process is to be determined using an empirical specific heat relation, constant specific heat at average temperature, and constant specific heat at room temperature.

Analysis (a) Using the empirical relation for $\bar{c}_p(T)$ from Table A-2c and relating it to $\bar{c}_v(T)$,

$$\bar{c}_v(T) = \bar{c}_p - R_u = (a - R_u) + bT + cT^2 + dT^3$$

where $a = 29.11$, $b = -0.1916 \times 10^{-2}$, $c = 0.4003 \times 10^{-5}$, and $d = -0.8704 \times 10^{-9}$. Then,

$$\begin{aligned} \Delta \bar{u} &= \int_1^2 \bar{c}_v(T) dT = \int_1^2 \left[(a - R_u) + bT + cT^2 + dT^3 \right] dT \\ &= (a - R_u)(T_2 - T_1) + \frac{1}{2}b(T_2^2 + T_1^2) + \frac{1}{3}c(T_2^3 - T_1^3) + \frac{1}{4}d(T_2^4 - T_1^4) \\ &= (29.11 - 8.314)(800 - 200) - \frac{1}{2}(0.1961 \times 10^{-2})(800^2 - 200^2) \\ &\quad + \frac{1}{3}(0.4003 \times 10^{-5})(800^3 - 200^3) - \frac{1}{4}(0.8704 \times 10^{-9})(800^4 - 200^4) \\ &= 12,487 \text{ kJ/kmol} \\ \Delta u &= \frac{\Delta \bar{u}}{M} = \frac{12,487 \text{ kJ/kmol}}{2.016 \text{ kg/kmol}} = \mathbf{6194 \text{ kJ/kg}} \end{aligned}$$

(b) Using a constant c_p value from Table A-2b at the average temperature of 500 K,

$$c_{v,\text{avg}} = c_{v@500\text{K}} = 10.389 \text{ kJ/kg} \cdot \text{K}$$

$$\Delta u = c_{v,\text{avg}}(T_2 - T_1) = (10.389 \text{ kJ/kg} \cdot \text{K})(800 - 200)\text{K} = \mathbf{6233 \text{ kJ/kg}}$$

(c) Using a constant c_p value from Table A-2a at room temperature,

$$c_{v,\text{avg}} = c_{v@300\text{K}} = 10.183 \text{ kJ/kg} \cdot \text{K}$$

$$\Delta u = c_{v,\text{avg}}(T_2 - T_1) = (10.183 \text{ kJ/kg} \cdot \text{K})(800 - 200)\text{K} = \mathbf{6110 \text{ kJ/kg}}$$

4-55 The enthalpy change of nitrogen gas during a heating process is to be determined using an empirical specific heat relation, constant specific heat at average temperature, and constant specific heat at room temperature.

Analysis (a) Using the empirical relation for $\bar{c}_p(T)$ from Table A-2c,

$$\bar{c}_p = a + bT + cT^2 + dT^3$$

where $a = 28.90$, $b = -0.1571 \times 10^{-2}$, $c = 0.8081 \times 10^{-5}$, and $d = -2.873 \times 10^{-9}$. Then,

$$\begin{aligned} \Delta \bar{h} &= \int_1^2 \bar{c}_p(T) dT = \int_1^2 [a + bT + cT^2 + dT^3] dT \\ &= a(T_2 - T_1) + \frac{1}{2}b(T_2^2 - T_1^2) + \frac{1}{3}c(T_2^3 - T_1^3) + \frac{1}{4}d(T_2^4 - T_1^4) \\ &= 28.90(1000 - 600) - \frac{1}{2}(0.1571 \times 10^{-2})(1000^2 - 600^2) \\ &\quad + \frac{1}{3}(0.8081 \times 10^{-5})(1000^3 - 600^3) - \frac{1}{4}(2.873 \times 10^{-9})(1000^4 - 600^4) \\ &= 12,544 \text{ kJ/kmol} \end{aligned}$$

$$\Delta h = \frac{\Delta \bar{h}}{M} = \frac{12,544 \text{ kJ/kmol}}{28.013 \text{ kg/kmol}} = \mathbf{447.8 \text{ kJ/kg}}$$

(b) Using the constant c_p value from Table A-2b at the average temperature of 800 K,

$$\begin{aligned} c_{p,\text{avg}} &= c_{p@800\text{K}} = 1.121 \text{ kJ/kg} \cdot \text{K} \\ \Delta h &= c_{p,\text{avg}}(T_2 - T_1) = (1.121 \text{ kJ/kg} \cdot \text{K})(1000 - 600)\text{K} = \mathbf{448.4 \text{ kJ/kg}} \end{aligned}$$

(c) Using the constant c_p value from Table A-2a at room temperature,

$$\begin{aligned} c_{p,\text{avg}} &= c_{p@300\text{K}} = 1.039 \text{ kJ/kg} \cdot \text{K} \\ \Delta h &= c_{p,\text{avg}}(T_2 - T_1) = (1.039 \text{ kJ/kg} \cdot \text{K})(1000 - 600)\text{K} = \mathbf{415.6 \text{ kJ/kg}} \end{aligned}$$

4-56E A spring-loaded piston-cylinder device is filled with air. The air is now cooled until its volume decreases by 50%. The changes in the internal energy and enthalpy of the air are to be determined.

Assumptions At specified conditions, air behaves as an ideal gas.

Properties The gas constant of air is $R = 0.3704 \text{ psia}\cdot\text{ft}^3/\text{lbm}\cdot\text{R}$ (Table A-1E). The specific heats of air at room temperature are $c_v = 0.171 \text{ Btu}/\text{lbm}\cdot\text{R}$ and $c_p = 0.240 \text{ Btu}/\text{lbm}\cdot\text{R}$ (Table A-2Ea).

Analysis The mass of the air in this system is

$$m = \frac{P_1 V_1}{RT_1} = \frac{(250 \text{ psia})(1 \text{ ft}^3)}{(0.3704 \text{ psia}\cdot\text{ft}^3/\text{lbm}\cdot\text{R})(460 + 460 \text{ R})} = 0.7336 \text{ lbm}$$

The final specific volume is then

$$v_2 = \frac{V_2}{m} = \frac{0.5(1 \text{ ft}^3)}{0.7336 \text{ lbm}} = 0.6816 \text{ ft}^3/\text{lbm}$$

As the volume of the air decreased, the length of the spring will increase by

$$\Delta x = \frac{\Delta V}{A_p} = \frac{\Delta V}{\pi D^2 / 4} = \frac{4(0.5 \text{ ft}^3)}{\pi(10/12 \text{ ft})^2} = 0.9167 \text{ ft} = 11.00 \text{ in}$$

The final pressure is then

$$\begin{aligned} P_2 &= P_1 - \Delta P = P_1 - \frac{\Delta F}{A_p} = P_1 - \frac{k\Delta x}{A_p} = P_1 - \frac{k\Delta x}{\pi D^2 / 4} \\ &= 250 \text{ psia} - \frac{4(5 \text{ lbf/in})(11.00 \text{ in})}{\pi(10 \text{ in})^2} = 249.3 \text{ lbf/in}^2 \\ &= 249.3 \text{ psia} \end{aligned}$$

Employing the ideal gas equation of state, the final temperature will be

$$T_2 = \frac{P_2 V_2}{mR} = \frac{(249.3 \text{ psia})(0.5 \text{ ft}^3)}{(0.7336 \text{ lbm})(0.3704 \text{ psia}\cdot\text{ft}^3/\text{lbm}\cdot\text{R})} = 458.7 \text{ R}$$

Using the specific heats,

$$\begin{aligned} \Delta u &= c_v \Delta T = (0.171 \text{ Btu}/\text{lbm}\cdot\text{R})(458.7 - 920) \text{ R} = \mathbf{-78.9 \text{ Btu}/\text{lbm}} \\ \Delta h &= c_p \Delta T = (0.240 \text{ Btu}/\text{lbm}\cdot\text{R})(458.7 - 920) \text{ R} = \mathbf{-110.7 \text{ Btu}/\text{lbm}} \end{aligned}$$

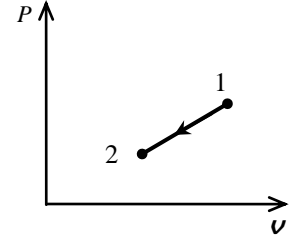

Closed System Energy Analysis: Ideal Gases

4-57C No, it isn't. This is because the first law relation $Q - W = \Delta U$ reduces to $W = 0$ in this case since the system is adiabatic ($Q = 0$) and $\Delta U = 0$ for the isothermal processes of ideal gases. Therefore, this adiabatic system cannot receive any net work at constant temperature.

4-58 The hydrogen gas in a rigid tank is cooled until its temperature drops to 300 K. The final pressure in the tank and the amount of heat transfer are to be determined.

Assumptions 1 Hydrogen is an ideal gas since it is at a high temperature and low pressure relative to its critical point values of -240°C and 1.30 MPa. **2** The tank is stationary, and thus the kinetic and potential energy changes are negligible, $\Delta ke \cong \Delta pe \cong 0$.

Properties The gas constant of hydrogen is $R = 4.124 \text{ kPa}\cdot\text{m}^3/\text{kg}\cdot\text{K}$ (Table A-1). The constant volume specific heat of hydrogen at the average temperature of 450 K is, $c_{u,\text{avg}} = 10.377 \text{ kJ/kg}\cdot\text{K}$ (Table A-2).

Analysis (a) The final pressure of hydrogen can be determined from the ideal gas relation,

$$\frac{P_1 V}{T_1} = \frac{P_2 V}{T_2} \longrightarrow P_2 = \frac{T_2}{T_1} P_1 = \frac{350 \text{ K}}{550 \text{ K}} (250 \text{ kPa}) = \mathbf{159.1 \text{ kPa}}$$

(b) We take the hydrogen in the tank as the system. This is a *closed system* since no mass enters or leaves. The energy balance for this stationary closed system can be expressed as

$$\begin{aligned} \underbrace{E_{\text{in}} - E_{\text{out}}}_{\substack{\text{Net energy transfer} \\ \text{by heat, work, and mass}}} &= \underbrace{\Delta E_{\text{system}}}_{\substack{\text{Change in internal, kinetic,} \\ \text{potential, etc. energies}}} \\ -Q_{\text{out}} &= \Delta U \\ Q_{\text{out}} &= -\Delta U = -m(u_2 - u_1) \cong mC_v(T_1 - T_2) \end{aligned}$$

where

$$m = \frac{P_1 V}{RT_1} = \frac{(250 \text{ kPa})(3.0 \text{ m}^3)}{(4.124 \text{ kPa}\cdot\text{m}^3/\text{kg}\cdot\text{K})(550 \text{ K})} = 0.3307 \text{ kg}$$

Substituting into the energy balance,

$$Q_{\text{out}} = (0.33307 \text{ kg})(10.377 \text{ kJ/kg}\cdot\text{K})(550 - 350)\text{K} = \mathbf{686.2 \text{ kJ}}$$

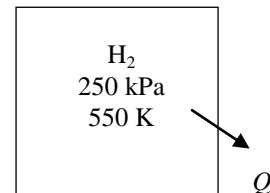

4-59E A paddle wheel in an oxygen tank is rotated until the pressure inside rises to 20 psia while some heat is lost to the surroundings. The paddle wheel work done is to be determined.

Assumptions 1 Oxygen is an ideal gas since it is at a high temperature and low pressure relative to its critical point values of -181°F and 736 psia. **2** The kinetic and potential energy changes are negligible, $\Delta ke \cong \Delta pe \cong 0$. **3** The energy stored in the paddle wheel is negligible. **4** This is a rigid tank and thus its volume remains constant.

Properties The gas constant and molar mass of oxygen are $R = 0.3353 \text{ psia}\cdot\text{ft}^3/\text{lbm}\cdot\text{R}$ and $M = 32 \text{ lbm/lbmol}$ (Table A-1E). The specific heat of oxygen at the average temperature of $T_{\text{avg}} = (735+540)/2 = 638 \text{ R}$ is $c_{v,\text{avg}} = 0.160 \text{ Btu/lbm}\cdot\text{R}$ (Table A-2E).

Analysis We take the oxygen in the tank as our system. This is a *closed system* since no mass enters or leaves. The energy balance for this system can be expressed as

$$\underbrace{E_{in} - E_{out}}_{\substack{\text{Net energy transfer} \\ \text{by heat, work, and mass}}} = \underbrace{\Delta E_{\text{system}}}_{\substack{\text{Change in internal, kinetic,} \\ \text{potential, etc. energies}}}$$

$$W_{pw,in} - Q_{out} = \Delta U$$

$$W_{pw,in} = Q_{out} + m(u_2 - u_1)$$

$$\cong Q_{out} + mc_v(T_2 - T_1)$$

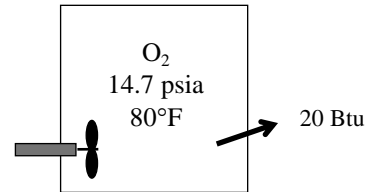

The final temperature and the mass of oxygen are

$$\frac{P_1 V}{T_1} = \frac{P_2 V}{T_2} \longrightarrow T_2 = \frac{P_2}{P_1} T_1 = \frac{20 \text{ psia}}{14.7 \text{ psia}} (540 \text{ R}) = 735 \text{ R}$$

$$m = \frac{P_1 V}{RT_1} = \frac{(14.7 \text{ psia})(10 \text{ ft}^3)}{(0.3353 \text{ psia} \cdot \text{ft}^3/\text{lbmol} \cdot \text{R})(540 \text{ R})} = 0.812 \text{ lbm}$$

Substituting,

$$W_{pw,in} = (20 \text{ Btu}) + (0.812 \text{ lbm})(0.160 \text{ Btu/lbm}\cdot\text{R})(735 - 540) \text{ R} = \mathbf{45.3 \text{ Btu}}$$

4-60E The air in a rigid tank is heated until its pressure doubles. The volume of the tank and the amount of heat transfer are to be determined.

Assumptions 1 Air is an ideal gas since it is at a high temperature and low pressure relative to its critical point values of - 221°F and 547 psia. **2** The kinetic and potential energy changes are negligible, $\Delta pe \cong \Delta ke \cong 0$. **3** Constant specific heats at room temperature can be used for air. This assumption results in negligible error in heating and air-conditioning applications.

Properties The gas constant of air is $R = 0.3704 \text{ psia} \cdot \text{ft}^3/\text{lbm} \cdot \text{R}$ (Table A-1E).

Analysis (a) The volume of the tank can be determined from the ideal gas relation,

$$V = \frac{mRT_1}{P_1} = \frac{(10 \text{ lbm})(0.3704 \text{ psia} \cdot \text{ft}^3/\text{lbm} \cdot \text{R})(525 \text{ R})}{30 \text{ psia}} = \mathbf{64.8 \text{ ft}^3}$$

(b) We take the air in the tank as our system. The energy balance for this stationary closed system can be expressed as

$$\underbrace{E_{\text{in}} - E_{\text{out}}}_{\substack{\text{Net energy transfer} \\ \text{by heat, work, and mass}}} = \underbrace{\Delta E_{\text{system}}}_{\substack{\text{Change in internal, kinetic,} \\ \text{potential, etc. energies}}}$$

$$Q_{\text{in}} = \Delta U$$

$$Q_{\text{in}} = m(u_2 - u_1) \cong mc_v(T_2 - T_1)$$

The final temperature of air is

$$\frac{P_1 V}{T_1} = \frac{P_2 V}{T_2} \longrightarrow T_2 = \frac{P_2}{P_1} T_1 = 2 \times (525 \text{ R}) = 1050 \text{ R}$$

The internal energies are (Table A-17E)

$$u_1 = u_{@525\text{R}} = 89.48 \text{ kJ/kg}$$

$$u_2 = u_{@1050\text{R}} = 181.48 \text{ kJ/kg}$$

Substituting,

$$Q_{\text{in}} = (10 \text{ lbm})(181.48 - 89.48) \text{ Btu/lbm} = \mathbf{920 \text{ Btu}}$$

Alternative solutions The specific heat of air at the average temperature of $T_{\text{avg}} = (525 + 1050)/2 = 788 \text{ R} = 328^\circ\text{F}$ is, from Table A-2Eb, $c_{v,\text{avg}} = 0.175 \text{ Btu/lbm} \cdot \text{R}$. Substituting,

$$Q_{\text{in}} = (10 \text{ lbm})(0.175 \text{ Btu/lbm} \cdot \text{R})(1050 - 525) \text{ R} = \mathbf{919 \text{ Btu}}$$

Discussion Both approaches resulted in almost the same solution in this case.

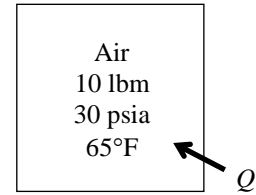

4-61E Paddle Wheel work is applied to nitrogen in a rigid container. The final temperature is to be determined.

Assumptions 1 Nitrogen is an ideal gas since it is at a high temperature and low pressure relative to its critical point values of 126.2 K (227.1 R) and 3.39 MPa (492 psia). **2** The kinetic and potential energy changes are negligible, $\Delta ke \cong \Delta pe \cong 0$. **3** Constant specific heats at room temperature can be used for nitrogen.

Properties For nitrogen, $c_v = 0.177$ Btu/lbm·R at room temperature and $R = 0.3830$ psia·ft³/lbm·R (Table A-1E and A-2Ea).

Analysis We take the nitrogen as the system. This is a *closed system* since no mass crosses the boundaries of the system. The energy balance for this system can be expressed as

$$\underbrace{E_{in} - E_{out}}_{\substack{\text{Net energy transfer} \\ \text{by heat, work, and mass}}} = \underbrace{\Delta E_{system}}_{\substack{\text{Change in internal, kinetic,} \\ \text{potential, etc. energies}}}$$

$$W_{pw,in} = \Delta U = mc_v(T_2 - T_1) \quad (\text{since KE} = \text{PE} = 0)$$

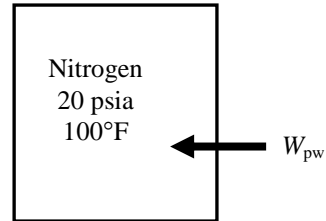

The mass of nitrogen is

$$m = \frac{P_1 V}{RT_1} = \frac{(20 \text{ psia})(1 \text{ ft}^3)}{(0.3830 \text{ psia} \cdot \text{ft}^3/\text{lbm} \cdot \text{R})(560 \text{ R})} = 0.09325 \text{ lbm}$$

Substituting,

$$W_{pw,in} = mc_v(T_2 - T_1)$$

$$(5000 \text{ lbf} \cdot \text{ft}) \frac{1 \text{ Btu}}{778.17 \text{ lbf} \cdot \text{ft}} = (0.09325 \text{ lbm})(0.177 \text{ Btu/lbm} \cdot \text{R})(T_2 - 560) \text{ R}$$

$$T_2 = \mathbf{949 \text{ R} = 489 \text{ F}}$$

4-62 One part of an insulated rigid tank contains an ideal gas while the other side is evacuated. The final temperature and pressure in the tank are to be determined when the partition is removed.

Assumptions 1 The kinetic and potential energy changes are negligible, $\Delta ke \cong \Delta pe \cong 0$. **2** The tank is insulated and thus heat transfer is negligible.

Analysis We take the entire tank as the system. This is a *closed system* since no mass crosses the boundaries of the system. The energy balance for this system can be expressed as

$$\underbrace{E_{in} - E_{out}}_{\substack{\text{Net energy transfer} \\ \text{by heat, work, and mass}}} = \underbrace{\Delta E_{system}}_{\substack{\text{Change in internal, kinetic,} \\ \text{potential, etc. energies}}}$$

$$0 = \Delta U = m(u_2 - u_1)$$

$$u_2 = u_1$$

Therefore,

$$T_2 = T_1 = \mathbf{50 \text{ C}}$$

Since $u = u(T)$ for an ideal gas. Then,

$$\frac{P_1 V_1}{T_1} = \frac{P_2 V_2}{T_2} \longrightarrow P_2 = \frac{V_1}{V_2} P_1 = \frac{1}{2} (800 \text{ kPa}) = \mathbf{400 \text{ kPa}}$$

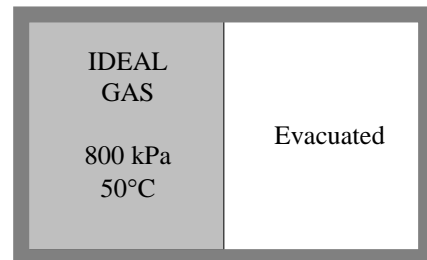

4-63 A resistance heater is to raise the air temperature in the room from 5 to 25°C within 11 min. The required power rating of the resistance heater is to be determined.

Assumptions 1 Air is an ideal gas since it is at a high temperature and low pressure relative to its critical point values of -141°C and 3.77 MPa. **2** The kinetic and potential energy changes are negligible, $\Delta ke \cong \Delta pe \cong 0$. **3** Constant specific heats at room temperature can be used for air. This assumption results in negligible error in heating and air-conditioning applications. **4** Heat losses from the room are negligible. **5** The room is air-tight so that no air leaks in and out during the process.

Properties The gas constant of air is $R = 0.287 \text{ kPa}\cdot\text{m}^3/\text{kg}\cdot\text{K}$ (Table A-1). Also, $c_v = 0.718 \text{ kJ}/\text{kg}\cdot\text{K}$ for air at room temperature (Table A-2).

Analysis We take the air in the room to be the system. This is a closed system since no mass crosses the system boundary. The energy balance for this stationary constant-volume closed system can be expressed as

$$\underbrace{E_{\text{in}} - E_{\text{out}}}_{\substack{\text{Net energy transfer} \\ \text{by heat, work, and mass}}} = \underbrace{\Delta E_{\text{system}}}_{\substack{\text{Change in internal, kinetic,} \\ \text{potential, etc. energies}}}$$

$$W_{e,\text{in}} = \Delta U \cong mc_{v,\text{avg}}(T_2 - T_1) \quad (\text{since } Q = \text{KE} = \text{PE} = 0)$$

or,

$$\dot{W}_{e,\text{in}} \Delta t = mc_{v,\text{avg}}(T_2 - T_1)$$

The mass of air is

$$V = 4 \times 5 \times 6 = 120 \text{ m}^3$$

$$m = \frac{P_1 V}{RT_1} = \frac{(100 \text{ kPa})(120 \text{ m}^3)}{(0.287 \text{ kPa}\cdot\text{m}^3/\text{kg}\cdot\text{K})(278 \text{ K})} = 150.6 \text{ kg}$$

Substituting, the power rating of the heater becomes

$$\dot{W}_{e,\text{in}} = \frac{(150.6 \text{ kg})(0.718 \text{ kJ}/\text{kg}\cdot^\circ\text{C})(25 - 5)^\circ\text{C}}{11 \times 60 \text{ s}} = \mathbf{3.28 \text{ kW}}$$

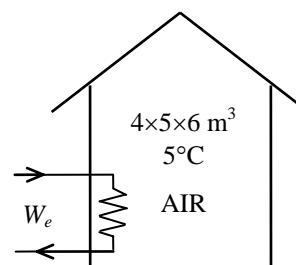

Discussion In practice, the pressure in the room will remain constant during this process rather than the volume, and some air will leak out as the air expands. As a result, the air in the room will undergo a constant pressure expansion process. Therefore, it is more proper to be conservative and to use ΔH instead of using ΔU in heating and air-conditioning applications.

4-64 A student living in a room turns her 150-W fan on in the morning. The temperature in the room when she comes back 10 h later is to be determined.

Assumptions 1 Air is an ideal gas since it is at a high temperature and low pressure relative to its critical point values of -141°C and 3.77 MPa. **2** The kinetic and potential energy changes are negligible, $\Delta ke \cong \Delta pe \cong 0$. **3** Constant specific heats at room temperature can be used for air. This assumption results in negligible error in heating and air-conditioning applications. **4** All the doors and windows are tightly closed, and heat transfer through the walls and the windows is disregarded.

Properties The gas constant of air is $R = 0.287 \text{ kPa}\cdot\text{m}^3/\text{kg}\cdot\text{K}$ (Table A-1). Also, $c_v = 0.718 \text{ kJ/kg}\cdot\text{K}$ for air at room temperature (Table A-2).

Analysis We take the room as the system. This is a *closed system* since the doors and the windows are said to be tightly closed, and thus no mass crosses the system boundary during the process. The energy balance for this system can be expressed as

$$\underbrace{E_{in} - E_{out}}_{\substack{\text{Net energy transfer} \\ \text{by heat, work, and mass}}} = \underbrace{\Delta E_{\text{system}}}_{\substack{\text{Change in internal, kinetic,} \\ \text{potential, etc. energies}}}$$

$$W_{e,in} = \Delta U$$

$$W_{e,in} = m(u_2 - u_1) \cong mc_v(T_2 - T_1)$$

The mass of air is

$$\mathcal{V} = 3 \times 4 \times 4 = 48 \text{ m}^3$$

$$m = \frac{P_1 \mathcal{V}}{RT_1} = \frac{(100 \text{ kPa})(48 \text{ m}^3)}{(0.287 \text{ kPa}\cdot\text{m}^3/\text{kg}\cdot\text{K})(293 \text{ K})} = 57.08 \text{ kg}$$

The electrical work done by the fan is

$$W_e = \dot{W}_e \Delta t = (0.100 \text{ kJ/s})(8 \times 3600 \text{ s}) = 2880 \text{ kJ}$$

Substituting and using the c_v value at room temperature,

$$2880 \text{ kJ} = (57.08 \text{ kg})(0.718 \text{ kJ/kg}\cdot^\circ\text{C})(T_2 - 20)^\circ\text{C}$$

$$T_2 = \mathbf{90.3^\circ\text{C}}$$

Discussion Note that a fan actually causes the internal temperature of a confined space to rise. In fact, a 100-W fan supplies a room with as much energy as a 100-W resistance heater.

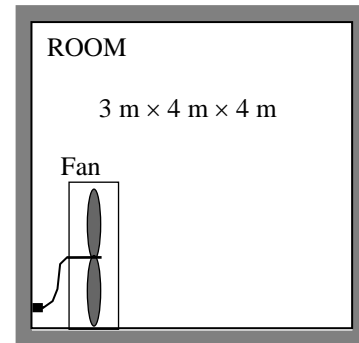

4-65 A room is heated by a radiator, and the warm air is distributed by a fan. Heat is lost from the room. The time it takes for the air temperature to rise to 20°C is to be determined.

Assumptions 1 Air is an ideal gas since it is at a high temperature and low pressure relative to its critical point values of -141°C and 3.77 MPa. **2** The kinetic and potential energy changes are negligible, $\Delta ke \cong \Delta pe \cong 0$. **3** Constant specific heats at room temperature can be used for air. This assumption results in negligible error in heating and air-conditioning applications. **4** The local atmospheric pressure is 100 kPa. **5** The room is air-tight so that no air leaks in and out during the process.

Properties The gas constant of air is $R = 0.287 \text{ kPa}\cdot\text{m}^3/\text{kg}\cdot\text{K}$ (Table A-1). Also, $c_v = 0.718 \text{ kJ/kg}\cdot\text{K}$ for air at room temperature (Table A-2).

Analysis We take the air in the room to be the system. This is a closed system since no mass crosses the system boundary. The energy balance for this stationary constant-volume closed system can be expressed as

$$\underbrace{E_{\text{in}} - E_{\text{out}}}_{\substack{\text{Net energy transfer} \\ \text{by heat, work, and mass}}} = \underbrace{\Delta E_{\text{system}}}_{\substack{\text{Change in internal, kinetic,} \\ \text{potential, etc. energies}}}$$

$$\dot{Q}_{\text{in}} + \dot{W}_{\text{fan, in}} - \dot{Q}_{\text{out}} = \Delta U \cong mc_{v, \text{avg}}(T_2 - T_1) \quad (\text{since } KE = PE = 0)$$

or,

$$(\dot{Q}_{\text{in}} + \dot{W}_{\text{fan, in}} - \dot{Q}_{\text{out}})\Delta t = mc_{v, \text{avg}}(T_2 - T_1)$$

The mass of air is

$$\mathcal{V} = 4 \times 5 \times 7 = 140 \text{ m}^3$$

$$m = \frac{P_1 \mathcal{V}}{RT_1} = \frac{(100 \text{ kPa})(140 \text{ m}^3)}{(0.287 \text{ kPa}\cdot\text{m}^3/\text{kg}\cdot\text{K})(283 \text{ K})} = 172.4 \text{ kg}$$

Using the c_v value at room temperature,

$$[(10,000 - 5,000)/3600 \text{ kJ/s} + 0.1 \text{ kJ/s}]\Delta t = (172.4 \text{ kg})(0.718 \text{ kJ/kg}\cdot^\circ\text{C})(20 - 10)^\circ\text{C}$$

It yields

$$\Delta t = \mathbf{831 \text{ s}}$$

Discussion In practice, the pressure in the room will remain constant during this process rather than the volume, and some air will leak out as the air expands. As a result, the air in the room will undergo a constant pressure expansion process. Therefore, it is more proper to be conservative and to use ΔH instead of use ΔU in heating and air-conditioning applications.

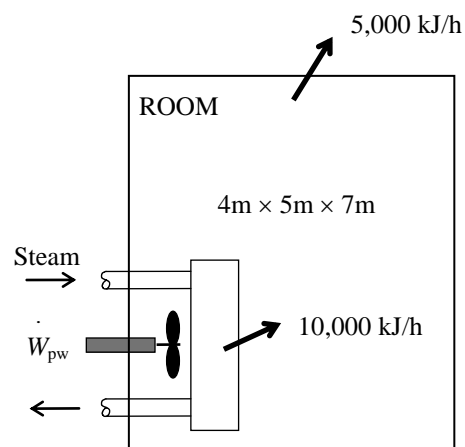

4-66 Argon is compressed in a polytropic process. The work done and the heat transfer are to be determined.

Assumptions 1 Argon is an ideal gas since it is at a high temperature and low pressure relative to its critical point values of 151 K and 4.86 MPa. **2** The kinetic and potential energy changes are negligible, $\Delta ke \cong \Delta pe \cong 0$.

Properties The properties of argon are $R = 0.2081 \text{ kJ/kg}\cdot\text{K}$ and $c_v = 0.3122 \text{ kJ/kg}\cdot\text{K}$ (Table A-2a).

Analysis We take argon as the system. This is a *closed system* since no mass crosses the boundaries of the system. The energy balance for this system can be expressed as

$$\underbrace{E_{\text{in}} - E_{\text{out}}}_{\substack{\text{Net energy transfer} \\ \text{by heat, work, and mass}}} = \underbrace{\Delta E_{\text{system}}}_{\substack{\text{Change in internal, kinetic,} \\ \text{potential, etc. energies}}}$$

$$Q_{\text{in}} - W_{b,\text{out}} = \Delta U = mc_v(T_2 - T_1)$$

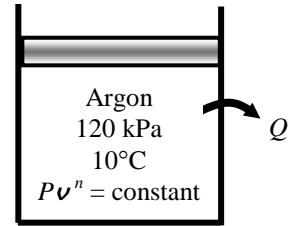

Using the boundary work relation for the polytropic process of an ideal gas gives

$$w_{b,\text{out}} = \frac{RT_1}{1-n} \left[\left(\frac{P_2}{P_1} \right)^{(n-1)/n} - 1 \right] = \frac{(0.2081 \text{ kJ/kg}\cdot\text{K})(283 \text{ K})}{1-1.2} \left[\left(\frac{800}{120} \right)^{0.2/1.2} - 1 \right] = -109.5 \text{ kJ/kg}$$

Thus,

$$w_{b,\text{in}} = \mathbf{109.5 \text{ kJ/kg}}$$

The temperature at the final state is

$$T_2 = T_1 \left(\frac{P_2}{P_1} \right)^{(n-1)/n} = (283 \text{ K}) \left(\frac{800 \text{ kPa}}{120 \text{ kPa}} \right)^{0.2/1.2} = 388.2 \text{ K}$$

From the energy balance equation,

$$q_{\text{in}} = w_{b,\text{out}} + c_v(T_2 - T_1) = -109.5 \text{ kJ/kg} + (0.3122 \text{ kJ/kg}\cdot\text{K})(388.2 - 283) \text{ K} = -76.6 \text{ kJ/kg}$$

Thus,

$$q_{\text{out}} = \mathbf{76.6 \text{ kJ/kg}}$$

4-67 An insulated cylinder is initially filled with air at a specified state. A paddle-wheel in the cylinder stirs the air at constant pressure. The final temperature of air is to be determined.

Assumptions 1 Air is an ideal gas with variable specific heats. 2 The cylinder is stationary and thus the kinetic and potential energy changes are zero. 3 There are no work interactions involved other than the boundary work. 4 The cylinder is well-insulated and thus heat transfer is negligible. 5 The thermal energy stored in the cylinder itself and the paddle-wheel is negligible. 6 The compression or expansion process is quasi-equilibrium.

Properties The gas constant of air is $R = 0.287 \text{ kPa}\cdot\text{m}^3/\text{kg}\cdot\text{K}$ (Table A-1). Also, $c_p = 1.005 \text{ kJ}/\text{kg}\cdot\text{K}$ for air at room temperature (Table A-2). The enthalpy of air at the initial temperature is

$$h_1 = h_{@298 \text{ K}} = 298.18 \text{ kJ}/\text{kg} \quad (\text{Table A-17})$$

Analysis We take the air in the cylinder as the system. This is a closed system since no mass enters or leaves. The energy balance for this stationary closed system can be expressed as

$$\underbrace{E_{in} - E_{out}}_{\substack{\text{Net energy transfer} \\ \text{by heat, work, and mass}}} = \underbrace{\Delta E_{\text{system}}}_{\substack{\text{Change in internal, kinetic,} \\ \text{potential, etc. energies}}}$$

$$W_{\text{pw},in} - W_{\text{b},out} = \Delta U \longrightarrow W_{\text{pw},in} = m(h_2 - h_1)$$

since $\Delta U + W_b = \Delta H$ during a constant pressure quasi-equilibrium process.

The mass of air is

$$m = \frac{P_1 \mathcal{V}}{RT_1} = \frac{(400 \text{ kPa})(0.1 \text{ m}^3)}{(0.287 \text{ kPa}\cdot\text{m}^3/\text{kg}\cdot\text{K})(298 \text{ K})} = 0.468 \text{ kg}$$

Substituting into the energy balance,

$$15 \text{ kJ} = (0.468 \text{ kg})(h_2 - 298.18 \text{ kJ}/\text{kg}) \rightarrow h_2 = 330.23 \text{ kJ}/\text{kg}$$

From Table A-17, $T_2 = \mathbf{329.9 \text{ K}}$

Alternative solution Using specific heats at room temperature, $c_p = 1.005 \text{ kJ}/\text{kg}\cdot^\circ\text{C}$, the final temperature is determined to be

$$W_{\text{pw},in} = m(h_2 - h_1) \cong mc_p(T_2 - T_1) \rightarrow 15 \text{ kJ} = (0.468 \text{ kg})(1.005 \text{ kJ}/\text{kg}\cdot^\circ\text{C})(T_2 - 25)^\circ\text{C}$$

which gives

$$T_2 = \mathbf{56.9^\circ\text{C}}$$

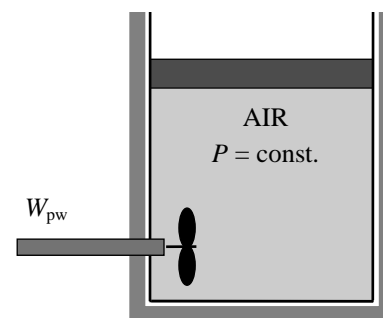

4-68 Carbon dioxide contained in a spring-loaded piston-cylinder device is heated. The work done and the heat transfer are to be determined.

Assumptions 1 CO₂ is an ideal gas since it is at a high temperature relative to its critical temperature of 304.2 K. 2 The kinetic and potential energy changes are negligible, $\Delta ke \cong \Delta pe \cong 0$.

Properties The properties of CO₂ are $R = 0.1889 \text{ kJ/kg}\cdot\text{K}$ and $c_v = 0.657 \text{ kJ/kg}\cdot\text{K}$ (Table A-2a).

Analysis We take CO₂ as the system. This is a *closed system* since no mass crosses the boundaries of the system. The energy balance for this system can be expressed as

$$\underbrace{E_{\text{in}} - E_{\text{out}}}_{\substack{\text{Net energy transfer} \\ \text{by heat, work, and mass}}} = \underbrace{\Delta E_{\text{system}}}_{\substack{\text{Change in internal, kinetic,} \\ \text{potential, etc. energies}}}$$

$$Q_{\text{in}} - W_{b,\text{out}} = \Delta U = mc_v(T_2 - T_1)$$

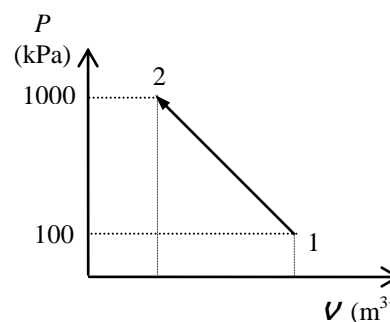

The initial and final specific volumes are

$$v_1 = \frac{mRT_1}{P_1} = \frac{(1 \text{ kg})(0.1889 \text{ kPa}\cdot\text{m}^3/\text{kg}\cdot\text{K})(298 \text{ K})}{100 \text{ kPa}} = 0.5629 \text{ m}^3$$

$$v_2 = \frac{mRT_2}{P_2} = \frac{(1 \text{ kg})(0.1889 \text{ kPa}\cdot\text{m}^3/\text{kg}\cdot\text{K})(573 \text{ K})}{1000 \text{ kPa}} = 0.1082 \text{ m}^3$$

Pressure changes linearly with volume and the work done is equal to the area under the process line 1-2:

$$W_{b,\text{out}} = \text{Area} = \frac{P_1 + P_2}{2}(v_2 - v_1)$$

$$= \frac{(100 + 1000)\text{kPa}}{2}(0.1082 - 0.5629)\text{m}^3 \left(\frac{1 \text{ kJ}}{1 \text{ kPa}\cdot\text{m}^3} \right)$$

$$= -250.1 \text{ kJ}$$

Thus,

$$W_{b,\text{in}} = \mathbf{250.1 \text{ kJ}}$$

Using the energy balance equation,

$$Q_{\text{in}} = W_{b,\text{out}} + mc_v(T_2 - T_1) = -250.1 \text{ kJ} + (1 \text{ kg})(0.657 \text{ kJ/kg}\cdot\text{K})(300 - 25)\text{K} = -69.4 \text{ kJ}$$

Thus,

$$Q_{\text{out}} = \mathbf{69.4 \text{ kJ}}$$

4-69E A cylinder is initially filled with nitrogen gas at a specified state. The gas is cooled by transferring heat from it. The amount of heat transfer is to be determined.

Assumptions 1 The cylinder is stationary and thus the kinetic and potential energy changes are zero. **2** There are no work interactions involved other than the boundary work. **3** The thermal energy stored in the cylinder itself is negligible. **4** The compression or expansion process is quasi-equilibrium. **5** Nitrogen is an ideal gas with constant specific heats.

Properties The gas constant of nitrogen is $0.3830 \text{ psia}\cdot\text{ft}^3/\text{lbm}\cdot\text{R}$. The specific heat of nitrogen at the average temperature of $T_{\text{avg}} = (700+200)/2 = 450^\circ\text{F}$ is $c_{p,\text{avg}} = 0.2525 \text{ Btu}/\text{lbm}\cdot^\circ\text{F}$ (Table A-2Eb).

Analysis We take the nitrogen gas in the cylinder as the system. This is a closed system since no mass enters or leaves. The energy balance for this closed system can be expressed as

$$\underbrace{E_{\text{in}} - E_{\text{out}}}_{\substack{\text{Net energy transfer} \\ \text{by heat, work, and mass}}} = \underbrace{\Delta E_{\text{system}}}_{\substack{\text{Change in internal, kinetic,} \\ \text{potential, etc. energies}}}$$

$$-Q_{\text{out}} - W_{b,\text{out}} = \Delta U = m(u_2 - u_1) \longrightarrow -Q_{\text{out}} = m(h_2 - h_1) = mc_p(T_2 - T_1)$$

since $\Delta U + W_b = \Delta H$ during a constant pressure quasi-equilibrium process. The mass of nitrogen is

$$m = \frac{P_1 V}{RT_1} = \frac{(40 \text{ psia})(25 \text{ ft}^3)}{(0.3830 \text{ psia}\cdot\text{ft}^3/\text{lbm}\cdot\text{R})(1160 \text{ R})} = 2.251 \text{ lbm}$$

Substituting,

$$Q_{\text{out}} = (2.251 \text{ lbm})(0.2525 \text{ Btu}/\text{lbm}\cdot^\circ\text{F})(700 - 200)^\circ\text{F} = \mathbf{284.2 \text{ Btu}}$$

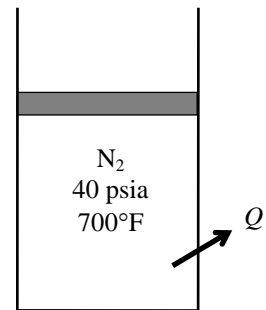

4-70 A piston-cylinder device contains air. A paddle wheel supplies a given amount of work to the air. The heat transfer is to be determined.

Assumptions 1 Air is an ideal gas since it is at a high temperature and low pressure relative to its critical point values of 132.5 K and 3.77 MPa . **2** The kinetic and potential energy changes are negligible, $\Delta ke \cong \Delta pe \cong 0$. **3** Constant specific heats can be used for air.

Analysis We take the air as the system. This is a *closed system* since no mass crosses the boundaries of the system. The energy balance for this system can be expressed as

$$\underbrace{E_{\text{in}} - E_{\text{out}}}_{\substack{\text{Net energy transfer} \\ \text{by heat, work, and mass}}} = \underbrace{\Delta E_{\text{system}}}_{\substack{\text{Change in internal, kinetic,} \\ \text{potential, etc. energies}}}$$

$$W_{\text{pw,in}} - W_{b,\text{out}} + Q_{\text{in}} = \Delta U = mc_v(T_2 - T_1)$$

$$W_{\text{pw,in}} - W_{b,\text{out}} + Q_{\text{in}} = 0 \quad (\text{since } T_1 = T_2)$$

$$Q_{\text{in}} = W_{b,\text{out}} - W_{\text{pw,in}}$$

Using the boundary work relation on a unit mass basis for the isothermal process of an ideal gas gives

$$w_{b,\text{out}} = RT \ln \frac{v_2}{v_1} = RT \ln 3 = (0.287 \text{ kJ}/\text{kg}\cdot\text{K})(290 \text{ K}) \ln 3 = 91.4 \text{ kJ}/\text{kg}$$

Substituting into the energy balance equation (expressed on a unit mass basis) gives

$$q_{\text{in}} = w_{b,\text{out}} - w_{\text{pw,in}} = 91.4 - 75 = \mathbf{16.4 \text{ kJ}/\text{kg}}$$

Discussion Note that the energy content of the system remains constant in this case, and thus the total energy transfer output via boundary work must equal the total energy input via shaft work and heat transfer.

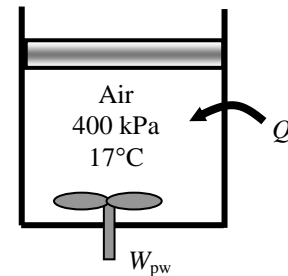

4-71 A cylinder is initially filled with air at a specified state. Air is heated electrically at constant pressure, and some heat is lost in the process. The amount of electrical energy supplied is to be determined.

Assumptions 1 The cylinder is stationary and thus the kinetic and potential energy changes are zero. **2** Air is an ideal gas with variable specific heats. **3** The thermal energy stored in the cylinder itself and the resistance wires is negligible. **4** The compression or expansion process is quasi-equilibrium.

Properties The initial and final enthalpies of air are (Table A-17)

$$h_1 = h_{@298\text{ K}} = 298.18 \text{ kJ/kg}$$

$$h_2 = h_{@350\text{ K}} = 350.49 \text{ kJ/kg}$$

Analysis We take the contents of the cylinder as the system. This is a closed system since no mass enters or leaves. The energy balance for this closed system can be expressed as

$$\underbrace{E_{in} - E_{out}}_{\text{Net energy transfer by heat, work, and mass}} = \underbrace{\Delta E_{\text{system}}}_{\text{Change in internal, kinetic, potential, etc. energies}}$$

$$W_{e,in} - Q_{out} - W_{b,out} = \Delta U \longrightarrow W_{e,in} = m(h_2 - h_1) + Q_{out}$$

since $\Delta U + W_b = \Delta H$ during a constant pressure quasi-equilibrium process. Substituting,

$$W_{e,in} = (15 \text{ kg})(350.49 - 298.18) \text{ kJ/kg} + (60 \text{ kJ}) = 845 \text{ kJ}$$

or,

$$W_{e,in} = (845 \text{ kJ}) \left(\frac{1 \text{ kWh}}{3600 \text{ kJ}} \right) = \mathbf{0.235 \text{ kWh}}$$

Alternative solution The specific heat of air at the average temperature of $T_{\text{avg}} = (25 + 77)/2 = 51^\circ\text{C} = 324 \text{ K}$ is, from Table A-2b, $c_{p,\text{avg}} = 1.0065 \text{ kJ/kg}\cdot^\circ\text{C}$. Substituting,

$$W_{e,in} = mc_p(T_2 - T_1) + Q_{out} = (15 \text{ kg})(1.0065 \text{ kJ/kg}\cdot^\circ\text{C})(77 - 25)^\circ\text{C} + 60 \text{ kJ} = 845 \text{ kJ}$$

or,

$$W_{e,in} = (845 \text{ kJ}) \left(\frac{1 \text{ kWh}}{3600 \text{ kJ}} \right) = \mathbf{0.235 \text{ kWh}}$$

Discussion Note that for small temperature differences, both approaches give the same result.

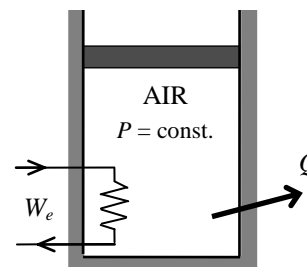

4-72 A cylinder initially contains nitrogen gas at a specified state. The gas is compressed polytropically until the volume is reduced by one-half. The work done and the heat transfer are to be determined.

Assumptions 1 The cylinder is stationary and thus the kinetic and potential energy changes are zero. **2** The N_2 is an ideal gas with constant specific heats. **3** The thermal energy stored in the cylinder itself is negligible. **4** The compression or expansion process is quasi-equilibrium.

Properties The gas constant of N_2 is $R = 0.2968 \text{ kPa}\cdot\text{m}^3/\text{kg}\cdot\text{K}$ (Table A-1). The c_v value of N_2 at the anticipated average temperature of 350 K is $0.744 \text{ kJ/kg}\cdot\text{K}$ (Table A-2b).

Analysis We take the contents of the cylinder as the system. This is a closed system since no mass crosses the system boundary. The energy balance for this closed system can be expressed as

$$\underbrace{E_{\text{in}} - E_{\text{out}}}_{\substack{\text{Net energy transfer} \\ \text{by heat, work, and mass}}} = \underbrace{\Delta E_{\text{system}}}_{\substack{\text{Change in internal, kinetic,} \\ \text{potential, etc. energies}}}$$

$$W_{\text{b,in}} - Q_{\text{out}} = \Delta U = m(u_2 - u_1)$$

$$W_{\text{b,in}} - Q_{\text{out}} = mc_v(T_2 - T_1)$$

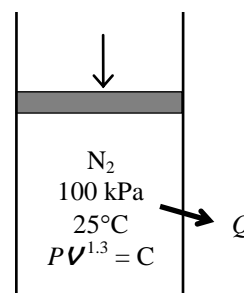

The final pressure and temperature of nitrogen are

$$P_2 V_2^{1.3} = P_1 V_1^{1.3} \longrightarrow P_2 = \left(\frac{V_1}{V_2} \right)^{1.3} P_1 = 2^{1.3} (100 \text{ kPa}) = 246.2 \text{ kPa}$$

$$\frac{P_1 V_1}{T_1} = \frac{P_2 V_2}{T_2} \longrightarrow T_2 = \frac{P_2}{P_1} \frac{V_2}{V_1} T_1 = \frac{246.2 \text{ kPa}}{100 \text{ kPa}} \times 0.5 \times (298 \text{ K}) = 366.9 \text{ K}$$

Then the boundary work for this polytropic process can be determined from

$$W_{\text{b,in}} = - \int_1^2 P dV = - \frac{P_2 V_2 - P_1 V_1}{1-n} = - \frac{mR(T_2 - T_1)}{1-n}$$

$$= - \frac{(2.2 \text{ kg})(0.2968 \text{ kJ/kg}\cdot\text{K})(366.9 - 298)\text{K}}{1-1.3} = \mathbf{149.9 \text{ kJ}}$$

Substituting into the energy balance gives

$$Q_{\text{out}} = W_{\text{b,in}} - mc_v(T_2 - T_1)$$

$$= 149.9 \text{ kJ} - (2.2 \text{ kg})(0.744 \text{ kJ/kg}\cdot\text{K})(366.9 - 298)\text{K}$$

$$= \mathbf{37.2 \text{ kJ}}$$



4-73 Problem 4-72 is reconsidered. The process is to be plotted on a P - V diagram, and the effect of the polytropic exponent n on the boundary work and heat transfer as the polytropic exponent varies from 1.0 to 1.4 is to be investigated. The boundary work and the heat transfer are to be plotted versus the polytropic exponent.

Analysis The problem is solved using EES, and the solution is given below.

```

Procedure   Work(P[2],V[2],P[1],V[1],n:W_in)
If n=1 then
W_in=-P[1]*V[1]*ln(V[2]/V[1])
Else
W_in=-(P[2]*V[2]-P[1]*V[1])/(1-n)
endif
End

```

"Input Data"

```

Vratio=0.5 "V[2]/V[1] = Vratio"
"n=1.3" "Polytropic exponent"
P[1] = 100 [kPa]
T[1] = (25+273) [K]
m=2.2 [kg]
MM=molar mass(nitrogen)
R_u=8.314 [kJ/kmol-K]
R=R_u/MM

```

```
V[1]=m*R*T[1]/P[1]
```

"Process equations"

```

V[2]=Vratio*V[1]
P[2]*V[2]/T[2]=P[1]*V[1]/T[1]"The combined ideal gas law for
states 1 and 2 plus the polytropic process relation give P[2] and T[2]"
P[2]*V[2]^n=P[1]*V[1]^n

```

"Conservation of Energy for the closed system:"

" $E_{in} - E_{out} = \Delta E$, we neglect ΔKE and ΔPE for the system, the nitrogen."

```

Q_out= W_in-m*(u[2]-u[1])
u[1]=intenergy(N2, T=T[1]) "internal energy for nitrogen as an ideal gas, kJ/kg"
u[2]=intenergy(N2, T=T[2])
Call Work(P[2],V[2],P[1],V[1],n:W_in)

```

"The following is required for the P-v plots"

```

{P_plot*spv_plot/T_plot=P[1]*V[1]/m/T[1]
"The combined ideal gas law for states 1 and 2 plus the polytropic process relation give P[2] and T[2]"
P_plot*spv_plot^n=P[1]*(V[1]/m)^n}
{spV_plot=R*T_plot/P_plot"[m^3]"}

```

Pressure vs. specific volume as function of polytropic exponent

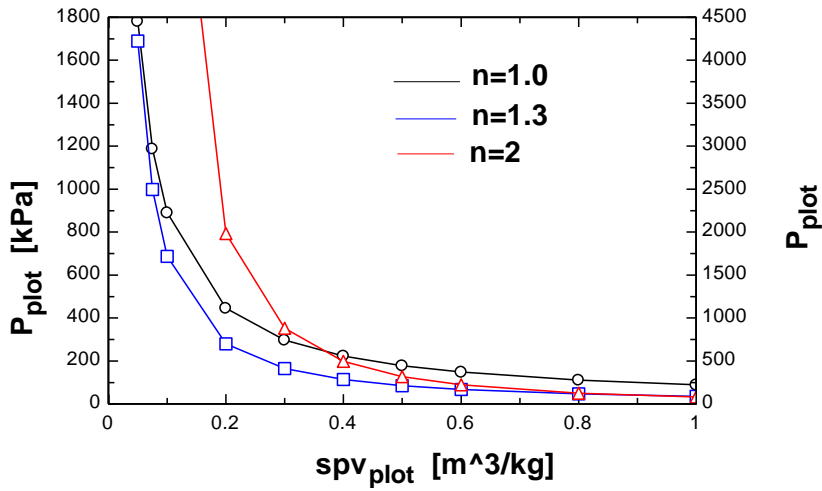

n	Q _{out} [kJ]	W _{in} [kJ]
1	134.9	134.9
1.044	121.8	137
1.089	108.2	139.1
1.133	94.25	141.3
1.178	79.8	143.5
1.222	64.86	145.8
1.267	49.42	148.1
1.311	33.45	150.5
1.356	16.93	152.9
1.4	-0.1588	155.4

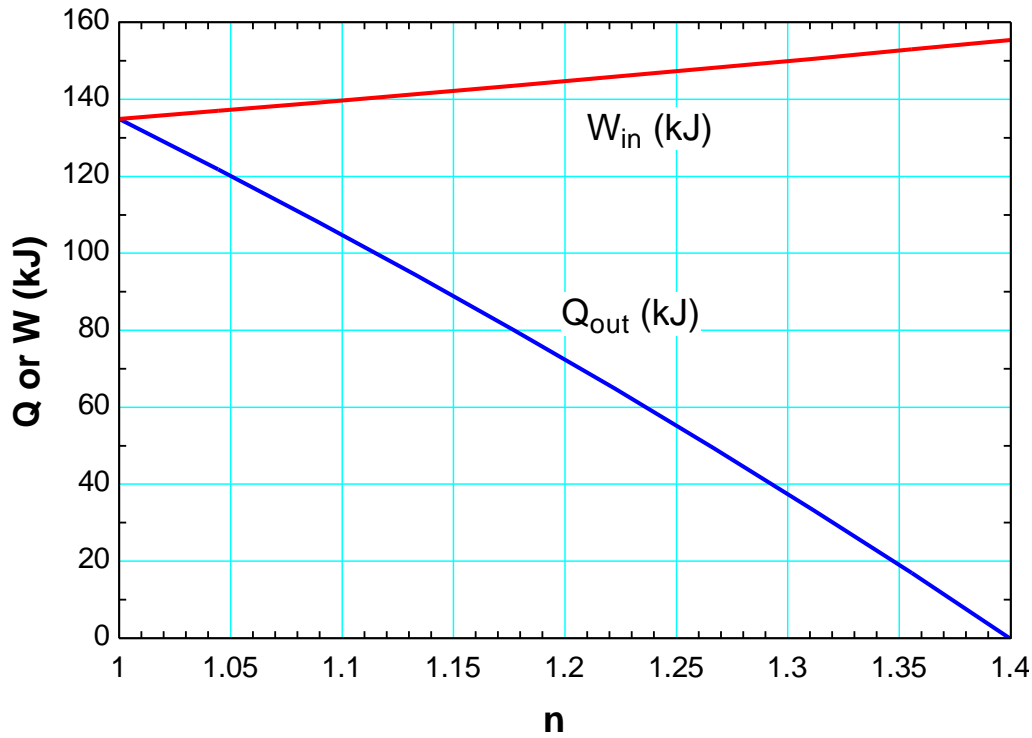

4-74E A cylinder initially contains air at a specified state. Heat is transferred to the air, and air expands isothermally. The boundary work done is to be determined.

Assumptions 1 The cylinder is stationary and thus the kinetic and potential energy changes are zero. **2** The air is an ideal gas with constant specific heats. **3** The compression or expansion process is quasi-equilibrium.

Analysis We take the contents of the cylinder as the system. This is a closed system since no mass crosses the system boundary. The energy balance for this closed system can be expressed as

$$\underbrace{E_{\text{in}} - E_{\text{out}}}_{\substack{\text{Net energy transfer} \\ \text{by heat, work, and mass}}} = \underbrace{\Delta E_{\text{system}}}_{\substack{\text{Change in internal, kinetic,} \\ \text{potential, etc. energies}}}$$

$$Q_{\text{in}} - W_{\text{b,out}} = \Delta U = m(u_2 - u_1) = mc_v(T_2 - T_1) = 0$$

since $u = u(T)$ for ideal gases, and thus $u_2 = u_1$ when $T_1 = T_2$. Therefore,

$$W_{\text{b,out}} = Q_{\text{in}} = \mathbf{40 \text{ Btu}}$$

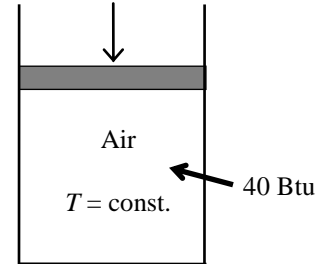



4-75 A cylinder equipped with a set of stops on the top is initially filled with air at a specified state. Heat is transferred to the air until the piston hits the stops, and then the pressure doubles. The work done by the air and the amount of heat transfer are to be determined, and the process is to be shown on a P - v diagram.

Assumptions 1 Air is an ideal gas with variable specific heats. 2 The kinetic and potential energy changes are negligible, $\Delta ke \cong \Delta pe \cong 0$. 3 The thermal energy stored in the cylinder itself is negligible.

Properties The gas constant of air is $R = 0.287 \text{ kPa}\cdot\text{m}^3/\text{kg}\cdot\text{K}$ (Table A-1).

Analysis We take the air in the cylinder to be the system. This is a closed system since no mass crosses the boundary of the system. The energy balance for this closed system can be expressed as

$$\underbrace{E_{\text{in}} - E_{\text{out}}}_{\substack{\text{Net energy transfer} \\ \text{by heat, work, and mass}}} = \underbrace{\Delta E_{\text{system}}}_{\substack{\text{Change in internal, kinetic,} \\ \text{potential, etc. energies}}}$$

$$Q_{\text{in}} - W_{\text{b,out}} = \Delta U = m(u_3 - u_1)$$

$$Q_{\text{in}} = m(u_3 - u_1) + W_{\text{b,out}}$$

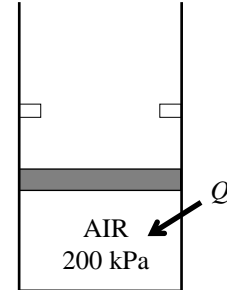

The initial and the final volumes and the final temperature of air are determined from

$$V_1 = \frac{mRT_1}{P_1} = \frac{(3 \text{ kg})(0.287 \text{ kPa}\cdot\text{m}^3/\text{kg}\cdot\text{K})(300 \text{ K})}{200 \text{ kPa}} = 1.29 \text{ m}^3$$

$$V_3 = 2V_1 = 2 \times 1.29 = 2.58 \text{ m}^3$$

$$\frac{P_1 V_1}{T_1} = \frac{P_3 V_3}{T_3} \longrightarrow T_3 = \frac{P_3 V_3}{P_1 V_1} T_1 = \frac{400 \text{ kPa}}{200 \text{ kPa}} \times 2 \times (300 \text{ K}) = 1200 \text{ K}$$

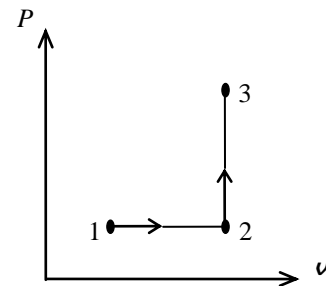

No work is done during process 2-3 since $V_2 = V_3$. The pressure remains constant during process 1-2 and the work done during this process is

$$W_b = \int_1^2 P dV = P_2 (V_2 - V_1)$$

$$= (200 \text{ kPa})(2.58 - 1.29) \text{ m}^3 \left(\frac{1 \text{ kJ}}{1 \text{ kPa}\cdot\text{m}^3} \right) = \mathbf{258 \text{ kJ}}$$

The initial and final internal energies of air are (Table A-17)

$$u_1 = u_{@300\text{K}} = 214.07 \text{ kJ/kg}$$

$$u_3 = u_{@1200\text{K}} = 933.33 \text{ kJ/kg}$$

Substituting,

$$Q_{\text{in}} = (3 \text{ kg})(933.33 - 214.07) \text{ kJ/kg} + 258 \text{ kJ} = \mathbf{2416 \text{ kJ}}$$

Alternative solution The specific heat of air at the average temperature of $T_{\text{avg}} = (300 + 1200)/2 = 750 \text{ K}$ is, from Table A-2b, $c_{\text{avg}} = 0.800 \text{ kJ/kg}\cdot\text{K}$. Substituting

$$Q_{\text{in}} = m(u_3 - u_1) + W_{\text{b,out}} \cong mc_v(T_3 - T_1) + W_{\text{b,out}}$$

$$= (3 \text{ kg})(0.800 \text{ kJ/kg}\cdot\text{K})(1200 - 300) \text{ K} + 258 \text{ kJ} = \mathbf{2418 \text{ kJ}}$$

4-76 Air at a specified state contained in a piston-cylinder device with a set of stops is heated until a final temperature. The amount of heat transfer is to be determined.

Assumptions **1** Air is an ideal gas since it is at a high temperature relative to its critical temperature of 304.2 K. **2** The kinetic and potential energy changes are negligible, $\Delta ke \cong \Delta pe \cong 0$.

Properties The properties of air are $R = 0.287 \text{ kJ/kg}\cdot\text{K}$ and $c_v = 0.718 \text{ kJ/kg}\cdot\text{K}$ (Table A-2a).

Analysis We take air as the system. This is a *closed system* since no mass crosses the boundaries of the system. The energy balance for this system can be expressed as

$$\underbrace{E_{\text{in}} - E_{\text{out}}}_{\substack{\text{Net energy transfer} \\ \text{by heat, work, and mass}}} = \underbrace{\Delta E_{\text{system}}}_{\substack{\text{Change in internal, kinetic,} \\ \text{potential, etc. energies}}}$$

$$Q_{\text{in}} - W_{b,\text{out}} = \Delta U = mc_v(T_2 - T_1)$$

The volume will be constant until the pressure is 200 kPa:

$$T_2 = T_1 \frac{P_2}{P_1} = (296 \text{ K}) \frac{200 \text{ kPa}}{100 \text{ kPa}} = 592 \text{ K}$$

The mass of the air is

$$m = \frac{P_1 V_1}{RT_1} = \frac{(100 \text{ kPa})(0.25 \text{ m}^3)}{(0.287 \text{ kPa}\cdot\text{m}^3/\text{kg}\cdot\text{K})(296 \text{ K})} = 0.2943 \text{ kg}$$

The boundary work done during process 2-3 is

$$\begin{aligned} W_{b,\text{out}} &= P_2(V_3 - V_2) = mR(T_3 - T_2) \\ &= (0.2943 \text{ kg})(0.287 \text{ kPa}\cdot\text{m}^3/\text{kg}\cdot\text{K})(700 - 592)\text{K} \\ &= 9.12 \text{ kJ} \end{aligned}$$

Substituting these values into energy balance equation,

$$Q_{\text{in}} = W_{b,\text{out}} + mc_v(T_3 - T_1) = 9.12 \text{ kJ} + (0.2943 \text{ kg})(0.718 \text{ kJ/kg}\cdot\text{K})(700 - 296)\text{K} = \mathbf{94.5 \text{ kJ}}$$

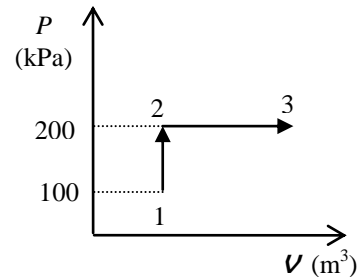
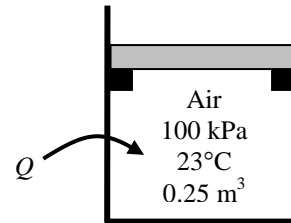

4-77 Air at a specified state contained in a piston-cylinder device undergoes an isothermal and constant volume process until a final temperature. The process is to be sketched on the P - V diagram and the amount of heat transfer is to be determined.

Assumptions **1** Air is an ideal gas since it is at a high temperature relative to its critical temperature of 304.2 K. **2** The kinetic and potential energy changes are negligible, $\Delta ke \cong \Delta pe \cong 0$.

Properties The properties of air are $R = 0.287 \text{ kJ/kg}\cdot\text{K}$ and $c_v = 0.718 \text{ kJ/kg}\cdot\text{K}$ (Table A-2a).

Analysis (a) The processes 1-2 (isothermal) and 2-3 (constant-volume) are sketched on the P - V diagram as shown.

(b) We take air as the system. This is a *closed system* since no mass crosses the boundaries of the system. The energy balance for this system for the process 1-3 can be expressed as

$$\underbrace{E_{\text{in}} - E_{\text{out}}}_{\text{Net energy transfer by heat, work, and mass}} = \underbrace{\Delta E_{\text{system}}}_{\text{Change in internal, kinetic, potential, etc. energies}}$$

$$-W_{b,\text{out},1-2} + Q_{\text{in}} = \Delta U = mc_v(T_3 - T_1)$$

The mass of the air is

$$m = \frac{P_1 V_1}{RT_1} = \frac{(600 \text{ kPa})(0.8 \text{ m}^3)}{(0.287 \text{ kPa}\cdot\text{m}^3/\text{kg}\cdot\text{K})(1200 \text{ K})} = 1.394 \text{ kg}$$

The work during process 1-2 is determined from boundary work relation for an isothermal process to be

$$W_{b,\text{out},1-2} = mRT_1 \ln \frac{V_2}{V_1} = mRT_1 \ln \frac{P_1}{P_2}$$

$$= (1.394 \text{ kg})(0.287 \text{ kPa}\cdot\text{m}^3/\text{kg}\cdot\text{K})(1200 \text{ K}) \ln \frac{600 \text{ kPa}}{300 \text{ kPa}}$$

$$= 332.8 \text{ kJ}$$

since $\frac{V_2}{V_1} = \frac{P_1}{P_2}$ for an isothermal process.

Substituting these values into energy balance equation,

$$Q_{\text{in}} = W_{b,\text{out},1-2} + mc_v(T_3 - T_1)$$

$$= 332.8 \text{ kJ} + (1.394 \text{ kg})(0.718 \text{ kJ/kg}\cdot\text{K})(300 - 1200) \text{ K}$$

$$= \mathbf{-568 \text{ kJ}}$$

Thus,

$$Q_{\text{out}} = \mathbf{568 \text{ kJ}}$$

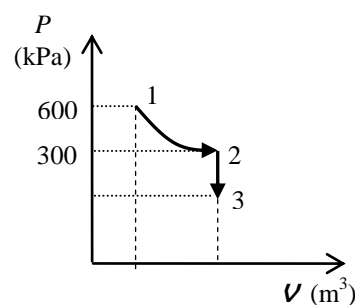
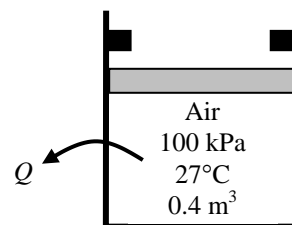

4-78 A cylinder initially contains argon gas at a specified state. The gas is stirred while being heated and expanding isothermally. The amount of heat transfer is to be determined.

Assumptions 1 The cylinder is stationary and thus the kinetic and potential energy changes are zero. **2** The air is an ideal gas with constant specific heats. **3** The compression or expansion process is quasi-equilibrium.

Analysis We take the contents of the cylinder as the system. This is a closed system since no mass crosses the system boundary. The energy balance for this closed system can be expressed as

$$\underbrace{E_{in} - E_{out}}_{\substack{\text{Net energy transfer} \\ \text{by heat, work, and mass}}} = \underbrace{\Delta E_{system}}_{\substack{\text{Change in internal, kinetic,} \\ \text{potential, etc. energies}}}$$

$$Q_{in} + W_{pw,in} - W_{b,out} = \Delta U = m(u_2 - u_1) = mc_v(T_2 - T_1) = 0$$

since $u = u(T)$ for ideal gases, and thus $u_2 = u_1$ when $T_1 = T_2$. Therefore,

$$Q_{in} = W_{b,out} - W_{pw,in} = 15 - 3 = \mathbf{12 \text{ kJ}}$$

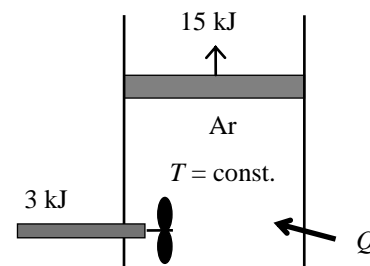

Closed System Energy Analysis: Solids and Liquids

4-79E Liquid water experiences a process from one state to another. The internal energy and enthalpy changes are to be determined under different assumptions.

Analysis (a) Using the properties from compressed liquid tables

$$u_1 \cong u_{f@50^\circ\text{F}} = 18.07 \text{ Btu/lbm} \quad (\text{Table A-4E})$$

$$h_1 = h_{f@50^\circ\text{F}} + v_f(P - P_{\text{sat}@T})$$

$$= 18.07 \text{ Btu/lbm} + (0.01602 \text{ ft}^3/\text{lbm})(50 - 0.17812) \text{ psia} \left(\frac{1 \text{ Btu}}{5.404 \text{ psia} \cdot \text{ft}^3} \right) = 18.21 \text{ Btu/lbm}$$

$$\left. \begin{array}{l} P_2 = 2000 \text{ psia} \\ T_2 = 100^\circ\text{F} \end{array} \right\} \begin{array}{l} u_2 = 67.36 \text{ Btu/lbm} \\ h_2 = 73.30 \text{ Btu/lbm} \end{array} \quad (\text{Table A-7E})$$

$$\Delta u = u_2 - u_1 = 67.36 - 18.07 = \mathbf{49.29 \text{ Btu/lbm}}$$

$$\Delta h = h_2 - h_1 = 73.30 - 18.21 = \mathbf{55.08 \text{ Btu/lbm}}$$

(b) Using incompressible substance approximation and property tables (Table A-4E),

$$u_1 \cong u_{f@50^\circ\text{F}} = 18.07 \text{ Btu/lbm}$$

$$h_1 \cong h_{f@50^\circ\text{F}} = 18.07 \text{ Btu/lbm}$$

$$u_2 \cong u_{f@100^\circ\text{F}} = 68.03 \text{ Btu/lbm}$$

$$h_2 \cong h_{f@100^\circ\text{F}} = 68.03 \text{ Btu/lbm}$$

$$\Delta u = u_2 - u_1 = 68.03 - 18.07 = \mathbf{49.96 \text{ Btu/lbm}}$$

$$\Delta h = h_2 - h_1 = 68.03 - 18.07 = \mathbf{49.96 \text{ Btu/lbm}}$$

(c) Using specific heats and taking the specific heat of water to be 1.00 Btu/lbm·R (Table A-3Ea),

$$\Delta h = \Delta u = c\Delta T = (1.00 \text{ Btu/lbm} \cdot \text{R})(100 - 50)\text{R} = \mathbf{50 \text{ Btu/lbm}}$$

4-80E A person shakes a canned drink in a iced water to cool it. The mass of the ice that will melt by the time the canned drink is cooled to a specified temperature is to be determined.

Assumptions **1** The thermal properties of the drink are constant, and are taken to be the same as those of water. **2** The effect of agitation on the amount of ice melting is negligible. **3** The thermal energy capacity of the can itself is negligible, and thus it does not need to be considered in the analysis.

Properties The density and specific heat of water at the average temperature of $(85+37)/2 = 61^\circ\text{F}$ are $\rho = 62.3 \text{ lbm/ft}^3$, and $c_p = 1.0 \text{ Btu/lbm}\cdot^\circ\text{F}$ (Table A-3E). The heat of fusion of water is 143.5 Btu/lbm .

Analysis We take a canned drink as the system. The energy balance for this closed system can be expressed as

$$\underbrace{E_{\text{in}} - E_{\text{out}}}_{\substack{\text{Net energy transfer} \\ \text{by heat, work, and mass}}} = \underbrace{\Delta E_{\text{system}}}_{\substack{\text{Change in internal, kinetic,} \\ \text{potential, etc. energies}}} \\ -Q_{\text{out}} = \Delta U_{\text{canned drink}} = m(u_2 - u_1) \longrightarrow Q_{\text{out}} = mc(T_1 - T_2)$$

Cola
85°F

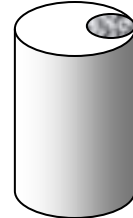

Noting that $1 \text{ gal} = 128 \text{ oz}$ and $1 \text{ ft}^3 = 7.48 \text{ gal} = 957.5 \text{ oz}$, the total amount of heat transfer from a ball is

$$m = \rho V = (62.3 \text{ lbm/ft}^3)(12 \text{ oz/can}) \left(\frac{1 \text{ ft}^3}{7.48 \text{ gal}} \right) \left(\frac{1 \text{ gal}}{128 \text{ fluid oz}} \right) = 0.781 \text{ lbm/can} \\ Q_{\text{out}} = mc(T_1 - T_2) = (0.781 \text{ lbm/can})(1.0 \text{ Btu/lbm}\cdot^\circ\text{F})(85 - 37)^\circ\text{F} = 37.5 \text{ Btu/can}$$

Noting that the heat of fusion of water is 143.5 Btu/lbm , the amount of ice that will melt to cool the drink is

$$m_{\text{ice}} = \frac{Q_{\text{out}}}{h_{\text{if}}} = \frac{37.5 \text{ Btu/can}}{143.5 \text{ Btu/lbm}} = \mathbf{0.261 \text{ lbm}} \quad (\text{per can of drink})$$

since heat transfer to the ice must be equal to heat transfer from the can.

Discussion The actual amount of ice melted will be greater since agitation will also cause some ice to melt.

4-81 An iron whose base plate is made of an aluminum alloy is turned on. The minimum time for the plate to reach a specified temperature is to be determined.

Assumptions 1 It is given that 85 percent of the heat generated in the resistance wires is transferred to the plate. **2** The thermal properties of the plate are constant. **3** Heat loss from the plate during heating is disregarded since the minimum heating time is to be determined. **4** There are no changes in kinetic and potential energies. **5** The plate is at a uniform temperature at the end of the process.

Properties The density and specific heat of the aluminum alloy plate are given to be $\rho = 2770 \text{ kg/m}^3$ and $c_p = 875 \text{ kJ/kg}\cdot^\circ\text{C}$.

Analysis The mass of the iron's base plate is

$$m = \rho V = \rho LA = (2770 \text{ kg/m}^3)(0.005 \text{ m})(0.03 \text{ m}^2) = 0.4155 \text{ kg}$$

Noting that only 85 percent of the heat generated is transferred to the plate, the rate of heat transfer to the iron's base plate is

$$\dot{Q}_{\text{in}} = 0.90 \times 1000 \text{ W} = 900 \text{ W}$$

We take plate to be the system. The energy balance for this closed system can be expressed as

$$\underbrace{E_{\text{in}} - E_{\text{out}}}_{\substack{\text{Net energy transfer} \\ \text{by heat, work, and mass}}} = \underbrace{\Delta E_{\text{system}}}_{\substack{\text{Change in internal, kinetic,} \\ \text{potential, etc. energies}}}$$

$$\dot{Q}_{\text{in}} = \Delta U_{\text{plate}} = m(u_2 - u_1) \longrightarrow \dot{Q}_{\text{in}} \Delta t = mc(T_2 - T_1)$$

Solving for Δt and substituting,

$$\Delta t = \frac{mc\Delta T_{\text{plate}}}{\dot{Q}_{\text{in}}} = \frac{(0.4155 \text{ kg})(875 \text{ J/kg}\cdot^\circ\text{C})(200 - 22)^\circ\text{C}}{900 \text{ J/s}} = \mathbf{71.9 \text{ s}}$$

which is the time required for the plate temperature to reach the specified temperature.

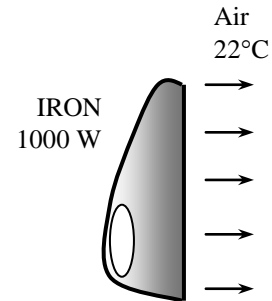

4-82 Stainless steel ball bearings leaving the oven at a specified uniform temperature at a specified rate are exposed to air and are cooled before they are dropped into the water for quenching. The rate of heat transfer from the ball bearing to the air is to be determined.

Assumptions 1 The thermal properties of the bearing balls are constant. **2** The kinetic and potential energy changes of the balls are negligible. **3** The balls are at a uniform temperature at the end of the process

Properties The density and specific heat of the ball bearings are given to be $\rho = 8085 \text{ kg/m}^3$ and $c_p = 0.480 \text{ kJ/kg} \cdot ^\circ\text{C}$.

Analysis We take a single bearing ball as the system.

The energy balance for this closed system can be expressed as

$$\underbrace{E_{\text{in}} - E_{\text{out}}}_{\text{Net energy transfer by heat, work, and mass}} = \underbrace{\Delta E_{\text{system}}}_{\text{Change in internal, kinetic, potential, etc. energies}}$$

$$-Q_{\text{out}} = \Delta U_{\text{ball}} = m(u_2 - u_1)$$

$$Q_{\text{out}} = mc(T_1 - T_2)$$

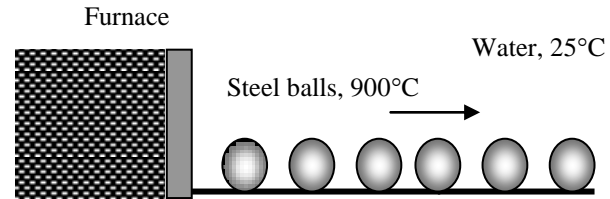

The total amount of heat transfer from a ball is

$$m = \rho V = \rho \frac{\pi D^3}{6} = (8085 \text{ kg/m}^3) \frac{\pi (0.012 \text{ m})^3}{6} = 0.007315 \text{ kg}$$

$$Q_{\text{out}} = mc(T_1 - T_2) = (0.007315 \text{ kg})(0.480 \text{ kJ/kg} \cdot ^\circ\text{C})(900 - 850)^\circ\text{C} = 0.1756 \text{ kJ/ball}$$

Then the rate of heat transfer from the balls to the air becomes

$$\dot{Q}_{\text{total}} = \dot{n}_{\text{ball}} Q_{\text{out(per ball)}} = (800 \text{ balls/min}) \times (0.1756 \text{ kJ/ball}) = \mathbf{140.5 \text{ kJ/min} = 2.34 \text{ kW}}$$

Therefore, heat is lost to the air at a rate of 2.34 kW.

4-83E Large brass plates are heated in an oven at a rate of 300/min. The rate of heat transfer to the plates in the oven is to be determined.

Assumptions 1 The thermal properties of the plates are constant. **2** The changes in kinetic and potential energies are negligible.

Properties The density and specific heat of the brass are given to be $\rho = 532.5 \text{ lbm/ft}^3$ and $c_p = 0.091 \text{ Btu/lbm} \cdot ^\circ\text{F}$.

Analysis We take the plate to be the system. The energy balance for this closed system can be expressed as

$$\underbrace{E_{\text{in}} - E_{\text{out}}}_{\text{Net energy transfer by heat, work, and mass}} = \underbrace{\Delta E_{\text{system}}}_{\text{Change in internal, kinetic, potential, etc. energies}}$$

$$Q_{\text{in}} = \Delta U_{\text{plate}} = m(u_2 - u_1) = mc(T_2 - T_1)$$

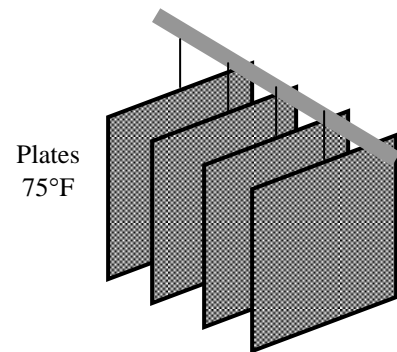

The mass of each plate and the amount of heat transfer to each plate is

$$m = \rho V = \rho LA = (532.5 \text{ lbm/ft}^3) [(1.6/12 \text{ ft})(2 \text{ ft})(2 \text{ ft})] = 284 \text{ lbm}$$

$$Q_{\text{in}} = mc(T_2 - T_1) = (284 \text{ lbm/plate})(0.091 \text{ Btu/lbm} \cdot ^\circ\text{F})(900 - 75)^\circ\text{F} = 21,320 \text{ Btu/plate}$$

Then the total rate of heat transfer to the plates becomes

$$\dot{Q}_{\text{total}} = \dot{n}_{\text{plate}} Q_{\text{in,per plate}} = (300 \text{ plates/min}) \times (21,320 \text{ Btu/plate}) = \mathbf{6,396,000 \text{ Btu/min} = 106,600 \text{ Btu/s}}$$

4-84 Long cylindrical steel rods are heat-treated in an oven. The rate of heat transfer to the rods in the oven is to be determined.

Assumptions 1 The thermal properties of the rods are constant. **2** The changes in kinetic and potential energies are negligible.

Properties The density and specific heat of the steel rods are given to be $\rho = 7833 \text{ kg/m}^3$ and $c_p = 0.465 \text{ kJ/kg}\cdot^\circ\text{C}$.

Analysis Noting that the rods enter the oven at a velocity of 2 m/min and exit at the same velocity, we can say that a 3-m long section of the rod is heated in the oven in 1 min. Then the mass of the rod heated in 1 minute is

$$m = \rho V = \rho LA = \rho L(\pi D^2 / 4) = (7833 \text{ kg/m}^3)(2 \text{ m})[\pi(0.08 \text{ m})^2 / 4] = 78.75 \text{ kg}$$

We take the 2-m section of the rod in the oven as the system. The energy balance for this closed system can be expressed as

$$\underbrace{E_{\text{in}} - E_{\text{out}}}_{\substack{\text{Net energy transfer} \\ \text{by heat, work, and mass}}} = \underbrace{\Delta E_{\text{system}}}_{\substack{\text{Change in internal, kinetic,} \\ \text{potential, etc. energies}}}$$

$$Q_{\text{in}} = \Delta U_{\text{rod}} = m(u_2 - u_1) = mc(T_2 - T_1)$$

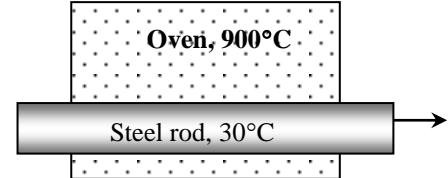

Substituting,

$$Q_{\text{in}} = mc(T_2 - T_1) = (78.75 \text{ kg})(0.465 \text{ kJ/kg}\cdot^\circ\text{C})(700 - 30)^\circ\text{C} = 24,530 \text{ kJ}$$

Noting that this much heat is transferred in 1 min, the rate of heat transfer to the rod becomes

$$\dot{Q}_{\text{in}} = Q_{\text{in}} / \Delta t = (24,530 \text{ kJ}) / (1 \text{ min}) = 24,530 \text{ kJ/min} = \mathbf{409 \text{ kW}}$$

4-85 An electronic device is on for 5 minutes, and off for several hours. The temperature of the device at the end of the 5-min operating period is to be determined for the cases of operation with and without a heat sink.

Assumptions 1 The device and the heat sink are isothermal. **2** The thermal properties of the device and of the sink are constant. **3** Heat loss from the device during on time is disregarded since the highest possible temperature is to be determined.

Properties The specific heat of the device is given to be $c_p = 850 \text{ J/kg}\cdot^\circ\text{C}$. The specific heat of aluminum at room temperature of 300 K is $902 \text{ J/kg}\cdot^\circ\text{C}$ (Table A-3).

Analysis We take the device to be the system. Noting that electrical energy is supplied, the energy balance for this closed system can be expressed as

$$\underbrace{E_{\text{in}} - E_{\text{out}}}_{\substack{\text{Net energy transfer} \\ \text{by heat, work, and mass}}} = \underbrace{\Delta E_{\text{system}}}_{\substack{\text{Change in internal, kinetic,} \\ \text{potential, etc. energies}}}$$

$$W_{\text{e,in}} = \Delta U_{\text{device}} = m(u_2 - u_1)$$

$$\dot{W}_{\text{e,in}} \Delta t = mc(T_2 - T_1)$$

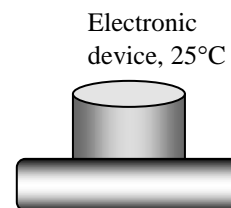

Substituting, the temperature of the device at the end of the process is determined to be

$$(25 \text{ J/s})(5 \times 60 \text{ s}) = (0.020 \text{ kg})(850 \text{ J/kg}\cdot^\circ\text{C})(T_2 - 25)^\circ\text{C} \rightarrow T_2 = \mathbf{466^\circ\text{C}} \text{ (without the heat sink)}$$

Case 2 When a heat sink is attached, the energy balance can be expressed as

$$W_{\text{e,in}} = \Delta U_{\text{device}} + \Delta U_{\text{heat sink}}$$

$$\dot{W}_{\text{e,in}} \Delta t = mc(T_2 - T_1)_{\text{device}} + mc(T_2 - T_1)_{\text{heat sink}}$$

Substituting, the temperature of the device-heat sink combination is determined to be

$$(25 \text{ J/s})(5 \times 60 \text{ s}) = (0.020 \text{ kg})(850 \text{ J/kg}\cdot^\circ\text{C})(T_2 - 25)^\circ\text{C} + (0.500 \text{ kg})(902 \text{ J/kg}\cdot^\circ\text{C})(T_2 - 25)^\circ\text{C}$$

$$T_2 = \mathbf{41.0^\circ\text{C}} \text{ (with heat sink)}$$

Discussion These are the maximum temperatures. In reality, the temperatures will be lower because of the heat losses to the surroundings.



4-86 Problem 4-85 is reconsidered. The effect of the mass of the heat sink on the maximum device temperature as the mass of heat sink varies from 0 kg to 1 kg is to be investigated. The maximum temperature is to be plotted against the mass of heat sink.

Analysis The problem is solved using EES, and the solution is given below.

"Knowns:"

"T_1 is the maximum temperature of the device"

Q_dot_out = 25 [W]

m_device=20 [g]

Cp_device=850 [J/kg-C]

A=5 [cm^2]

DELTA_t=5 [min]

T_amb=25 [C]

{m_sink=0.5 [kg]}

"Cp_al taken from Table A-3(b) at 300K"

Cp_al=0.902 [kJ/kg-C]

T_2=T_amb

"Solution:"

"The device without the heat sink is considered to be a closed system."

"Conservation of Energy for the closed system:"

"E_dot_in - E_dot_out = DELTAE_dot, we neglect DELTA KE and DELTA PE for the system, the device."

E_dot_in - E_dot_out = DELTAE_dot

E_dot_in = 0

E_dot_out = Q_dot_out

"Use the solid material approximation to find the energy change of the device."

DELTA_E_dot = m_device*convert(g,kg)*Cp_device*(T_2-T_1_device)/(DELTA_t*convert(min,s))

"The device with the heat sink is considered to be a closed system."

"Conservation of Energy for the closed system:"

"E_dot_in - E_dot_out = DELTAE_dot, we neglect DELTA KE and DELTA PE for the device with the heat sink."

E_dot_in - E_dot_out = DELTAE_dot_combined

"Use the solid material approximation to find the energy change of the device."

DELTA_E_dot_combined = (m_device*convert(g,kg)*Cp_device*(T_2-T_1_device&sink)+m_sink*Cp_al*(T_2-T_1_device&sink)*convert(kJ,J))/(DELTA_t*convert(min,s))

m _{sink} [kg]	T _{1,device&sink} [C]
0	466.2
0.1	94.96
0.2	62.99
0.3	51.08
0.4	44.85
0.5	41.03
0.6	38.44
0.7	36.57
0.8	35.15
0.9	34.05
1	33.16

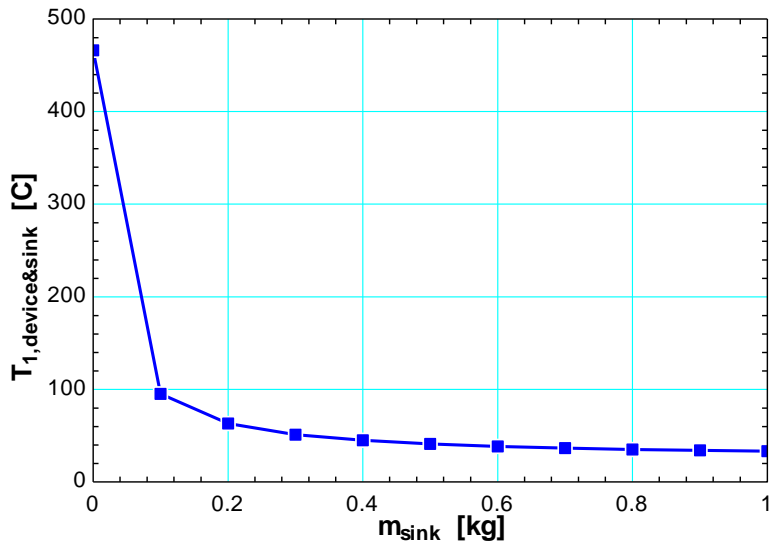

4-87 The face of a person is slapped. For the specified temperature rise of the affected part, the impact velocity of the hand is to be determined.

Assumptions **1** The hand is brought to a complete stop after the impact. **2** The face takes the blow without significant movement. **3** No heat is transferred from the affected area to the surroundings, and thus the process is adiabatic. **4** No work is done on or by the system. **5** The potential energy change is zero, $\Delta PE = 0$ and $\Delta E = \Delta U + \Delta KE$.

Analysis We analyze this incident in a professional manner without involving any emotions. First, we identify the system, draw a sketch of it, and state our observations about the specifics of the problem. We take the hand and the affected portion of the face as the *system*. This is a *closed system* since it involves a fixed amount of mass (no mass transfer). We observe that the kinetic energy of the hand decreases during the process, as evidenced by a decrease in velocity from initial value to zero, while the internal energy of the affected area increases, as evidenced by an increase in the temperature. There seems to be no significant energy transfer between the system and its surroundings during this process. Under the stated assumptions and observations, the energy balance on the system can be expressed as

$$\underbrace{E_{in} - E_{out}}_{\substack{\text{Net energy transfer} \\ \text{by heat, work, and mass}}} = \underbrace{\Delta E_{system}}_{\substack{\text{Change in internal, kinetic,} \\ \text{potential, etc. energies}}}$$

$$0 = \Delta U_{\text{affected tissue}} + \Delta KE_{\text{hand}}$$

$$0 = (mc\Delta T)_{\text{affected tissue}} + [m(0 - V^2)/2]_{\text{hand}}$$

That is, the decrease in the kinetic energy of the hand must be equal to the increase in the internal energy of the affected area. Solving for the velocity and substituting the given quantities, the impact velocity of the hand is determined to be

$$V_{\text{hand}} = \sqrt{\frac{2(mc\Delta T)_{\text{affected tissue}}}{m_{\text{hand}}}}$$

$$V_{\text{hand}} = \sqrt{\frac{2(0.15 \text{ kg})(3.8 \text{ kJ/kg} \cdot ^\circ\text{C})(2.4^\circ\text{C})}{0.9 \text{ kg}} \left(\frac{1000 \text{ m}^2/\text{s}^2}{1 \text{ kJ/kg}} \right)}$$

$$= \mathbf{55.1 \text{ m/s}} \text{ (or } 198 \text{ km/h)}$$

Discussion Reconstruction of events such as this by making appropriate assumptions are commonly used in forensic engineering.

4-88 A number of brass balls are to be quenched in a water bath at a specified rate. The rate at which heat needs to be removed from the water in order to keep its temperature constant is to be determined.

Assumptions **1** The thermal properties of the balls are constant. **2** The balls are at a uniform temperature before and after quenching. **3** The changes in kinetic and potential energies are negligible.

Properties The density and specific heat of the brass balls are given to be $\rho = 8522 \text{ kg/m}^3$ and $c_p = 0.385 \text{ kJ/kg}\cdot^\circ\text{C}$.

Analysis We take a single ball as the system. The energy balance for this closed system can be expressed as

$$\underbrace{E_{\text{in}} - E_{\text{out}}}_{\substack{\text{Net energy transfer} \\ \text{by heat, work, and mass}}} = \underbrace{\Delta E_{\text{system}}}_{\substack{\text{Change in internal, kinetic,} \\ \text{potential, etc. energies}}}$$

$$-Q_{\text{out}} = \Delta U_{\text{ball}} = m(u_2 - u_1)$$

$$Q_{\text{out}} = mC(T_1 - T_2)$$

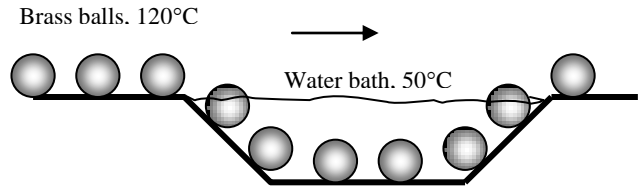

The total amount of heat transfer from a ball is

$$m = \rho V = \rho \frac{\pi D^3}{6} = (8522 \text{ kg/m}^3) \frac{\pi (0.05 \text{ m})^3}{6} = 0.558 \text{ kg}$$

$$Q_{\text{out}} = mc(T_1 - T_2) = (0.558 \text{ kg})(0.385 \text{ kJ/kg}\cdot^\circ\text{C})(120 - 74)^\circ\text{C} = 9.88 \text{ kJ/ball}$$

Then the rate of heat transfer from the balls to the water becomes

$$\dot{Q}_{\text{total}} = \dot{n}_{\text{ball}} Q_{\text{ball}} = (100 \text{ balls/min}) \times (9.88 \text{ kJ/ball}) = \mathbf{988 \text{ kJ/min}}$$

Therefore, heat must be removed from the water at a rate of 988 kJ/min in order to keep its temperature constant at 50°C since energy input must be equal to energy output for a system whose energy level remains constant. That is, $E_{\text{in}} = E_{\text{out}}$ when $\Delta E_{\text{system}} = 0$.

4-89 A number of aluminum balls are to be quenched in a water bath at a specified rate. The rate at which heat needs to be removed from the water in order to keep its temperature constant is to be determined.

Assumptions 1 The thermal properties of the balls are constant. 2 The balls are at a uniform temperature before and after quenching. 3 The changes in kinetic and potential energies are negligible.

Properties The density and specific heat of aluminum at the average temperature of $(120+74)/2 = 97^\circ\text{C} = 370\text{ K}$ are $\rho = 2700\text{ kg/m}^3$ and $c_p = 0.937\text{ kJ/kg}\cdot^\circ\text{C}$ (Table A-3).

Analysis We take a single ball as the system. The energy balance for this closed system can be expressed as

$$\underbrace{E_{in} - E_{out}}_{\substack{\text{Net energy transfer} \\ \text{by heat, work, and mass}}} = \underbrace{\Delta E_{system}}_{\substack{\text{Change in internal, kinetic,} \\ \text{potential, etc. energies}}}$$

$$-Q_{out} = \Delta U_{ball} = m(u_2 - u_1)$$

$$Q_{out} = mc(T_1 - T_2)$$

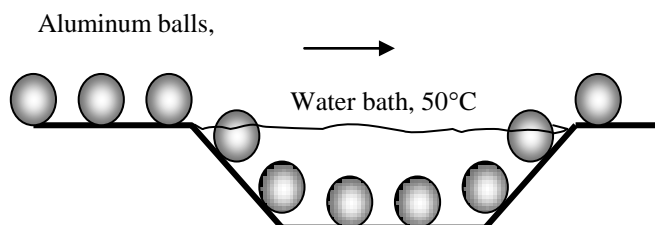

The total amount of heat transfer from a ball is

$$m = \rho V = \rho \frac{\pi D^3}{6} = (2700\text{ kg/m}^3) \frac{\pi (0.05\text{ m})^3}{6} = 0.1767\text{ kg}$$

$$Q_{out} = mc(T_1 - T_2) = (0.1767\text{ kg})(0.937\text{ kJ/kg}\cdot^\circ\text{C})(120 - 74)^\circ\text{C} = 7.62\text{ kJ/ball}$$

Then the rate of heat transfer from the balls to the water becomes

$$\dot{Q}_{total} = \dot{n}_{ball} Q_{ball} = (100\text{ balls/min}) \times (7.62\text{ kJ/ball}) = \mathbf{762\text{ kJ/min}}$$

Therefore, heat must be removed from the water at a rate of 762 kJ/min in order to keep its temperature constant at 50°C since energy input must be equal to energy output for a system whose energy level remains constant. That is, $E_{in} = E_{out}$ when $\Delta E_{system} = 0$.

Special Topic: Biological Systems

4-90C The food we eat is not entirely metabolized in the human body. The fraction of metabolizable energy contents are 95.5% for carbohydrates, 77.5% for proteins, and 97.7% for fats. Therefore, the metabolizable energy content of a food is not the same as the energy released when it is burned in a bomb calorimeter.

4-91C Yes. Each body rejects the heat generated during metabolism, and thus serves as a heat source. For an average adult male it ranges from 84 W at rest to over 1000 W during heavy physical activity. Classrooms are designed for a large number of occupants, and thus the total heat dissipated by the occupants must be considered in the design of heating and cooling systems of classrooms.

4-92C 1 kg of natural fat contains almost 8 times the metabolizable energy of 1 kg of natural carbohydrates. Therefore, a person who fills his stomach with carbohydrates will satisfy his hunger without consuming too many calories.

4-93 The average body temperature of the human body rises by 2°C during strenuous exercise. The increase in the thermal energy content of the body as a result is to be determined.

Properties The average specific heat of the human body is given to be 3.6 kJ/kg·°C.

Analysis The change in the sensible internal energy of the body is

$$\Delta U = mc\Delta T = (80 \text{ kg})(3.6 \text{ kJ/kg}\cdot\text{°C})(2\text{°C}) = \mathbf{576 \text{ kJ}}$$

as a result of body temperature rising 2°C during strenuous exercise.

4-94 Two men are identical except one jogs for 30 min while the other watches TV. The weight difference between these two people in one month is to be determined.

Assumptions The two people have identical metabolism rates, and are identical in every other aspect.

Properties An average 68-kg person consumes 540 Cal/h while jogging, and 72 Cal/h while watching TV (Table 4-2).

Analysis An 80-kg person who jogs 0.5 h a day will have jogged a total of 15 h a month, and will consume

$$\Delta E_{\text{consumed}} = [(540 - 72) \text{ Cal/h}](15 \text{ h}) \left(\frac{4.1868 \text{ kJ}}{1 \text{ Cal}} \right) \left(\frac{80 \text{ kg}}{68 \text{ kg}} \right) = 34,578 \text{ kJ}$$

more calories than the person watching TV. The metabolizable energy content of 1 kg of fat is 33,100 kJ. Therefore, the weight difference between these two people in 1-month will be

$$\Delta m_{\text{fat}} = \frac{\Delta E_{\text{consumed}}}{\text{Energy content of fat}} = \frac{34,578 \text{ kJ}}{33,100 \text{ kJ/kg}} = \mathbf{1.04 \text{ kg}}$$

4-95 A bicycling woman is to meet her entire energy needs by eating 30-g candy bars. The number of candy bars she needs to eat to bicycle for 1-h is to be determined.

Assumptions The woman meets her entire calorie needs from candy bars while bicycling.

Properties An average 68-kg person consumes 639 Cal/h while bicycling, and the energy content of a 20-g candy bar is 105 Cal (Tables 4-1 and 4-2).

Analysis Noting that a 20-g candy bar contains 105 Calories of metabolizable energy, a 30-g candy bar will contain

$$E_{\text{candy}} = (105 \text{ Cal}) \left(\frac{30 \text{ g}}{20 \text{ g}} \right) = 157.5 \text{ Cal}$$

of energy. If this woman is to meet her entire energy needs by eating 30-g candy bars, she will need to eat

$$N_{\text{candy}} = \frac{639 \text{ Cal/h}}{157.5 \text{ Cal}} \cong \mathbf{4 \text{ candybars/h}}$$

4-96 A 90-kg man eats 1-L of ice cream. The length of time this man needs to jog to burn off these calories is to be determined.

Assumptions The man meets his entire calorie needs from the ice cream while jogging.

Properties An average 68-kg person consumes 540 Cal/h while jogging, and the energy content of a 100-ml of ice cream is 110 Cal (Tables 4-1 and 4-2).

Analysis The rate of energy consumption of a 55-kg person while jogging is

$$\dot{E}_{\text{consumed}} = (540 \text{ Cal/h}) \left(\frac{90 \text{ kg}}{68 \text{ kg}} \right) = 715 \text{ Cal/h}$$

Noting that a 100-ml serving of ice cream has 110 Cal of metabolizable energy, a 1-liter box of ice cream will have 1100 Calories. Therefore, it will take

$$\Delta t = \frac{1100 \text{ Cal}}{715 \text{ Cal/h}} = \mathbf{1.54 \text{ h}}$$

of jogging to burn off the calories from the ice cream.

4-97 A man switches from an apple a day to 200-ml of ice cream and 20-min walk every day. The amount of weight the person will gain or lose with the new diet is to be determined.

Assumptions All the extra calories are converted to body fat.

Properties The metabolizable energy contents are 70 Cal for an apple and 220 Cal for a 200-ml serving of ice cream (Table 4-1). An average 68-kg man consumes 432 Cal/h while walking (Table 4-2). The metabolizable energy content of 1 kg of body fat is 33,100 kJ.

Analysis The person who switches from the apple to ice cream increases his calorie intake by

$$E_{\text{extra}} = 220 - 70 = 150 \text{ Cal}$$

The amount of energy a 60-kg person uses during a 20-min walk is

$$E_{\text{consumed}} = (432 \text{ Cal/h}) (20 \text{ min}) \left(\frac{1 \text{ h}}{60 \text{ min}} \right) \left(\frac{60 \text{ kg}}{68 \text{ kg}} \right) = 127 \text{ Cal}$$

Therefore, the man now has a net gain of $150 - 127 = 23$ Cal per day, which corresponds to $23 \times 30 = 690$ Cal per month. Therefore, the man will gain

$$m_{\text{fat}} = \frac{690 \text{ Cal}}{33,100 \text{ kJ/kg}} \left(\frac{4.1868 \text{ kJ}}{1 \text{ Cal}} \right) = \mathbf{0.087 \text{ kg}}$$

of body fat per month with the new diet. (Without the exercise the man would gain 0.569 kg per month).

4-98 A man with 20-kg of body fat goes on a hunger strike. The number of days this man can survive on the body fat alone is to be determined.

Assumptions 1 The person is an average male who remains in resting position at all times. **2** The man meets his entire calorie needs from the body fat alone.

Properties The metabolizable energy content of fat is 33,100 Cal/kg. An average resting person burns calories at a rate of 72 Cal/h (Table 4-2).

Analysis The metabolizable energy content of 20 kg of body fat is

$$E_{\text{fat}} = (33,100 \text{ kJ/kg})(20 \text{ kg}) = 662,000 \text{ kJ}$$

The person will consume

$$E_{\text{consumed}} = (72 \text{ Cal/h})(24 \text{ h}) \left(\frac{4.1868 \text{ kJ}}{1 \text{ Cal}} \right) = 7235 \text{ kJ/day}$$

Therefore, this person can survive

$$\Delta t = \frac{662,000 \text{ kJ}}{7235 \text{ kJ/day}} = \mathbf{91.5 \text{ days}}$$

on his body fat alone. This result is not surprising since people are known to survive over 100 days without any food intake.

4-99 Two 50-kg women are identical except one eats her baked potato with 4 teaspoons of butter while the other eats hers plain every evening. The weight difference between these two woman in one year is to be determined.

Assumptions 1 These two people have identical metabolism rates, and are identical in every other aspect. **2** All the calories from the butter are converted to body fat.

Properties The metabolizable energy content of 1 kg of body fat is 33,100 kJ. The metabolizable energy content of 1 teaspoon of butter is 35 Calories (Table 4-1).

Analysis A person who eats 4 teaspoons of butter a day will consume

$$E_{\text{consumed}} = (35 \text{ Cal/teaspoon})(4 \text{ teaspoons/day}) \left(\frac{365 \text{ days}}{1 \text{ year}} \right) = 51,100 \text{ Cal/year}$$

Therefore, the woman who eats her potato with butter will gain

$$m_{\text{fat}} = \frac{51,100 \text{ Cal}}{33,100 \text{ kJ/kg}} \left(\frac{4.1868 \text{ kJ}}{1 \text{ Cal}} \right) = \mathbf{6.5 \text{ kg}}$$

of additional body fat that year.

4-100 A woman switches from 1-L of regular cola a day to diet cola and 2 slices of apple pie. It is to be determined if she is now consuming more or less calories.

Properties The metabolizable energy contents are 300 Cal for a slice of apple pie, 87 Cal for a 200-ml regular cola, and 0 for the diet drink (Table 4-3).

Analysis The energy contents of 2 slices of apple pie and 1-L of cola are

$$E_{\text{pie}} = 2 \times (300 \text{ Cal}) = 600 \text{ Cal}$$

$$E_{\text{cola}} = 5 \times (87 \text{ Cal}) = 435 \text{ Cal}$$

Therefore, the woman is now consuming **more calories**.

4-101E A man and a woman have lunch at Burger King, and then shovel snow. The shoveling time it will take to burn off the lunch calories is to be determined for both.

Assumptions The food intake during lunch is completely metabolized by the body.

Properties The metabolizable energy contents of different foods are as given in the problem statement. Shoveling snow burns calories at a rate of 420 Cal/h for the woman and 610 Cal/h for the man (given).

Analysis The total calories consumed during lunch and the time it will take to burn them are determined for both the man and woman as follows:

Man: Lunch calories = $720 + 400 + 225 = 1345 \text{ Cal}$.

$$\text{Shoveling time: } \Delta t_{\text{shovelingman}} = \frac{1345 \text{ Cal}}{610 \text{ Cal/h}} = \mathbf{2.20 \text{ h}}$$

Woman: Lunch calories = $330 + 400 + 0 = 730 \text{ Cal}$.

$$\text{Shoveling time: } \Delta t_{\text{shovelingwoman}} = \frac{730 \text{ Cal}}{420 \text{ Cal/h}} = \mathbf{1.74 \text{ h}}$$

4-102 Three people have different lunches. The person who consumed the most calories from lunch is to be determined.

Properties The metabolizable energy contents of different foods are 530 Cal for the Big Mac, 640 Cal for the whopper, 350 Cal for french fries, and 5 Cal for each olive (given).

Analysis The total calories consumed by each person during lunch are:

Person 1: Lunch calories = 530 Cal

Person 2: Lunch calories = **640 Cal**

Person 3: Lunch calories = $350 + 5 \times 50 = 600 \text{ Cal}$

Therefore, the person with the Whopper will consume the most calories.

4-103 A 75-kg man decides to lose 5 kg by exercising without reducing his calorie intake. The number of days it will take for this man to lose 5 kg is to be determined.

Assumptions 1 The diet and exercise habits of the person remain the same other than the new daily exercise program. **2** The entire calorie deficiency is met by burning body fat.

Properties The metabolizable energy content of body fat is 33,100 Cal/kg (text).

Analysis The energy consumed by an average 68-kg adult during fast-swimming, fast dancing, jogging, biking, and relaxing are 860, 600, 540, 639, and 72 Cal/h, respectively (Table 4-2). The daily energy consumption of this 75-kg man is

$$\left[(860 + 600 + 540 + 639 \text{ Cal/h})(1 \text{ h}) + (72 \text{ Cal/h})(23 \text{ h}) \right] \left(\frac{75 \text{ kg}}{68 \text{ kg}} \right) = 4737 \text{ Cal}$$

Therefore, this person burns $4737 - 4000 = 737$ more Calories than he takes in, which corresponds to

$$m_{\text{fat}} = \frac{737 \text{ Cal}}{33,100 \text{ kJ/kg}} \left(\frac{4.1868 \text{ kJ}}{1 \text{ Cal}} \right) = 0.09324 \text{ kg}$$

of body fat per day. Thus it will take only

$$\Delta t = \frac{5 \text{ kg}}{0.09324 \text{ kg/day}} = \mathbf{53.6 \text{ days}}$$

for this man to lose 5 kg.

4-104E The range of healthy weight for adults is usually expressed in terms of the *body mass index* (BMI) in SI units as

$\text{BMI} = \frac{W(\text{kg})}{H^2(\text{m}^2)}$. This formula is to be converted to English units such that the weight is in pounds and the height in inches.

Analysis Noting that $1 \text{ kg} = 2.2 \text{ lbm}$ and $1 \text{ m} = 39.37 \text{ in}$, the weight in lbm must be divided by 2.2 to convert it to kg, and the height in inches must be divided by 39.37 to convert it to m before inserting them into the formula. Therefore,

$$\text{BMI} = \frac{W(\text{kg})}{H^2(\text{m}^2)} = \frac{W(\text{lbm})/2.2}{H^2(\text{in}^2)/(39.37)^2} = 705 \frac{W(\text{lbm})}{H^2(\text{in}^2)}$$

Every person can calculate their own BMI using either SI or English units, and determine if it is in the healthy range.

4-105 A person changes his/her diet to lose weight. The time it will take for the body mass index (BMI) of the person to drop from 30 to 20 is to be determined.

Assumptions The deficit in the calorie intake is made up by burning body fat.

Properties The metabolizable energy contents are 350 Cal for a slice of pizza and 87 Cal for a 200-ml regular cola. The metabolizable energy content of 1 kg of body fat is 33,100 kJ.

Analysis The lunch calories before the diet is

$$E_{\text{old}} = 3 \times e_{\text{pizza}} + 2 \times e_{\text{coke}} = 3 \times (350 \text{ Cal}) + 2 \times (87 \text{ Cal}) = 1224 \text{ Cal}$$

The lunch calories after the diet is

$$E_{\text{old}} = 2 \times e_{\text{pizza}} + 1 \times e_{\text{coke}} = 2 \times (350 \text{ Cal}) + 1 \times (87 \text{ Cal}) = 787 \text{ Cal}$$

The calorie reduction is

$$E_{\text{reduction}} = 1224 - 787 = 437 \text{ Cal}$$

The corresponding reduction in the body fat mass is

$$m_{\text{fat}} = \frac{437 \text{ Cal}}{33,100 \text{ kJ/kg}} \left(\frac{4.1868 \text{ kJ}}{1 \text{ Cal}} \right) = 0.05528 \text{ kg}$$

The weight of the person before and after the diet is

$$W_1 = \text{BMI}_1 \times h^2_{\text{pizza}} = 30 \times (1.6 \text{ m})^2 = 76.8 \text{ kg}$$

$$W_2 = \text{BMI}_2 \times h^2_{\text{pizza}} = 20 \times (1.6 \text{ m})^2 = 51.2 \text{ kg}$$

Then it will take

$$\text{Time} = \frac{W_1 - W_2}{m_{\text{fat}}} = \frac{(76.8 - 51.2) \text{ kg}}{0.05528 \text{ kg/day}} = \mathbf{463 \text{ days}}$$

for the BMI of this person to drop to 20.

4-106E An average American adult switches from drinking alcoholic beverages to drinking diet soda. The amount of weight the person will lose per year as a result of this switch is to be determined.

Assumptions 1 The diet and exercise habits of the person remain the same other than switching from alcoholic beverages to diet drinks. **2** All the excess calories from alcohol are converted to body fat.

Properties The metabolizable energy content of body fat is 33,100 Cal/kg (text).

Analysis When the person switches to diet drinks, he will consume 210 fewer Calories a day. Then the annual reduction in the calories consumed by the person becomes

$$\text{Reduction in energy intake: } E_{\text{reduced}} = (210 \text{ Cal/day})(365 \text{ days/year}) = 76,650 \text{ Cal/year}$$

Therefore, assuming all the calories from the alcohol would be converted to body fat, the person who switches to diet drinks will lose

$$\text{Reduction in weight} = \frac{\text{Reduction in energy intake}}{\text{Energy content of fat}} = \frac{E_{\text{reduced}}}{e_{\text{fat}}} = \frac{76,650 \text{ Cal/yr}}{33,100 \text{ kJ/kg}} \left(\frac{4.1868 \text{ kJ}}{1 \text{ Cal}} \right) = \mathbf{9.70 \text{ kg/yr}}$$

or about **21 pounds** of body fat that year.

Review Problems

4-107 For a 10°C temperature change of air, the final velocity and final elevation of air are to be determined so that the internal, kinetic and potential energy changes are equal.

Properties The constant-volume specific heat of air at room temperature is $0.718 \text{ kJ/kg}\cdot^\circ\text{C}$ (Table A-2).

Analysis The internal energy change is determined from

$$\Delta u = c_v \Delta T = (0.718 \text{ kJ/kg}\cdot^\circ\text{C})(10^\circ\text{C}) = 7.18 \text{ kJ/kg}$$

Equating kinetic and potential energy changes to internal energy change, the final velocity and elevation are determined from

$$\Delta u = \Delta ke = \frac{1}{2}(V_2^2 - V_1^2) \longrightarrow 7.18 \text{ kJ/kg} = \frac{1}{2}(V_2^2 - 0 \text{ m}^2/\text{s}^2) \left(\frac{1 \text{ kJ/kg}}{1000 \text{ m}^2/\text{s}^2} \right) \longrightarrow V_2 = \mathbf{120 \text{ m/s}}$$

$$\Delta u = \Delta pe = g(z_2 - z_1) \longrightarrow 7.18 \text{ kJ/kg} = (9.81 \text{ m/s}^2)(z_2 - 0 \text{ m}) \left(\frac{1 \text{ kJ/kg}}{1000 \text{ m}^2/\text{s}^2} \right) \longrightarrow z_2 = \mathbf{732 \text{ m}}$$

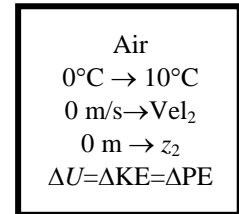

4-108 Heat is transferred to a piston-cylinder device containing air. The expansion work is to be determined.

Assumptions 1 There is no friction between piston and cylinder. **2** Air is an ideal gas.

Properties The gas constant for air is $0.287 \text{ kJ/kg}\cdot\text{K}$ (Table A-2a).

Analysis Noting that the gas constant represents the boundary work for a unit mass and a unit temperature change, the expansion work is simply determined from

$$W_b = m\Delta TR = (0.5 \text{ kg})(5 \text{ K})(0.287 \text{ kJ/kg}\cdot\text{K}) = \mathbf{0.7175 \text{ kJ}}$$

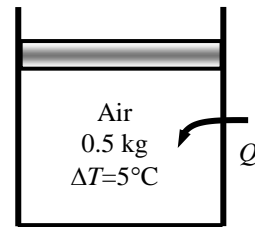

4-109E An insulated rigid vessel contains air. A paddle wheel supplies work to the air. The work supplied and final temperature are to be determined.

Assumptions **1** Air is an ideal gas since it is at a high temperature and low pressure relative to its critical point values of 238.5 R and 547 psia. **2** The kinetic and potential energy changes are negligible, $\Delta ke \cong \Delta pe \cong 0$. **3** Constant specific heats can be used for air.

Properties The specific heats of air at room temperature are $c_p = 0.240$ Btu/lbm·R and $c_v = 0.171$ Btu/lbm·R (Table A-2Ea).

Analysis We take the air as the system. This is a *closed system* since no mass crosses the boundaries of the system. The energy balance for this system can be expressed as

$$\underbrace{E_{in} - E_{out}}_{\substack{\text{Net energy transfer} \\ \text{by heat, work, and mass}}} = \underbrace{\Delta E_{system}}_{\substack{\text{Change in internal, kinetic,} \\ \text{potential, etc. energies}}}$$

$$W_{pw,in} = \Delta U = mc_v(T_2 - T_1)$$

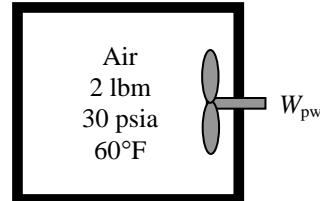

As the specific volume remains constant during this process, the ideal gas equation gives

$$T_2 = T_1 \frac{P_2}{P_1} = (520 \text{ R}) \frac{40 \text{ psia}}{30 \text{ psia}} = 693.3 \text{ R} = \mathbf{233.3^\circ\text{F}}$$

Substituting,

$$W_{pw,in} = mc_v(T_2 - T_1) = (2 \text{ lbm})(0.171 \text{ Btu/lbm}\cdot\text{R})(693.3 - 520)\text{R} = \mathbf{59.3 \text{ Btu}}$$

4-110 Air at a given state is expanded polytropically in a piston-cylinder device to a specified pressure. The final temperature is to be determined.

Analysis The polytropic relations for an ideal gas give

$$T_2 = T_1 \left(\frac{P_2}{P_1} \right)^{n-1/n} = (400 + 273 \text{ K}) \left(\frac{110 \text{ kPa}}{1000 \text{ kPa}} \right)^{0.2/1.2} = 466 \text{ K} = \mathbf{193^\circ\text{C}}$$

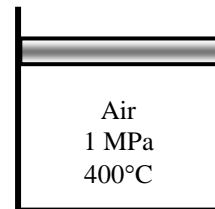

4-111 Nitrogen in a rigid vessel is heated. The work done and heat transfer are to be determined.

Assumptions **1** Nitrogen is an ideal gas since it is at a high temperature and low pressure relative to its critical point values of 126.2 K and 3.39 MPa. **2** The kinetic and potential energy changes are negligible, $\Delta ke \cong \Delta pe \cong 0$. **3** Constant specific heats at room temperature can be used for nitrogen.

Properties For nitrogen, $c_v = 0.743 \text{ kJ/kg}\cdot\text{K}$ at room temperature (Table A-2a).

Analysis We take the nitrogen as the system. This is a *closed system* since no mass crosses the boundaries of the system. The energy balance for this system can be expressed as

$$\underbrace{E_{\text{in}} - E_{\text{out}}}_{\substack{\text{Net energy transfer} \\ \text{by heat, work, and mass}}} = \underbrace{\Delta E_{\text{system}}}_{\substack{\text{Change in internal, kinetic,} \\ \text{potential, etc. energies}}}$$

$$Q_{\text{in}} = \Delta U = mc_v(T_2 - T_1)$$

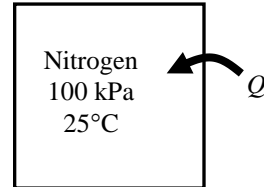

There is no work done since the vessel is rigid:

$$w = \mathbf{0 \text{ kJ/kg}}$$

Since the specific volume is constant during the process, the final temperature is determined from ideal gas equation to be

$$T_2 = T_1 \frac{P_2}{P_1} = (298 \text{ K}) \frac{300 \text{ kPa}}{100 \text{ psia}} = 894 \text{ K}$$

Substituting,

$$q_{\text{in}} = c_v(T_2 - T_1) = (0.743 \text{ kJ/kg}\cdot\text{K})(894 - 298)\text{K} = \mathbf{442.8 \text{ kJ/kg}}$$

4-112 A well-insulated rigid vessel contains saturated liquid water. Electrical work is done on water. The final temperature is to be determined.

Assumptions 1 The tank is stationary and thus the kinetic and potential energy changes are zero. **2** The thermal energy stored in the tank itself is negligible.

Analysis We take the contents of the tank as the system. This is a closed system since no mass enters or leaves. The energy balance for this stationary closed system can be expressed as

$$\underbrace{E_{\text{in}} - E_{\text{out}}}_{\substack{\text{Net energy transfer} \\ \text{by heat, work, and mass}}} = \underbrace{\Delta E_{\text{system}}}_{\substack{\text{Change in internal, kinetic,} \\ \text{potential, etc. energies}}}$$

$$W_{e,\text{in}} = \Delta U = m(u_2 - u_1)$$

The amount of electrical work added during 30 minutes period is

$$W_{e,\text{in}} = \mathbf{VI}\Delta t = (50 \text{ V})(10 \text{ A})(30 \times 60 \text{ s}) \left(\frac{1 \text{ W}}{1 \text{ VA}} \right) = 900,000 \text{ J} = 900 \text{ kJ}$$

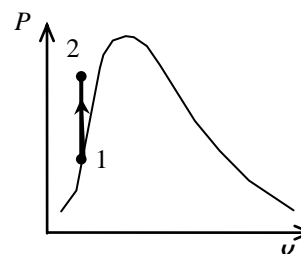

The properties at the initial state are (Table A-4)

$$u_1 = u_f @ 40^\circ\text{C} = 167.53 \text{ kJ/kg}$$

$$v_1 = v_f @ 40^\circ\text{C} = 0.001008 \text{ m}^3/\text{kg}.$$

Substituting,

$$W_{e,\text{in}} = m(u_2 - u_1) \longrightarrow u_2 = u_1 + \frac{W_{e,\text{in}}}{m} = 167.53 \text{ kJ/kg} + \frac{900 \text{ kJ}}{3 \text{ kg}} = 467.53 \text{ kJ/kg}$$

The final state is compressed liquid. Noting that the specific volume is constant during the process, the final temperature is determined using EES to be

$$\left. \begin{array}{l} u_2 = 467.53 \text{ kJ/kg} \\ v_2 = v_1 = 0.001008 \text{ m}^3/\text{kg} \end{array} \right\} T_2 = \mathbf{118.9^\circ\text{C}} \quad (\text{from EES})$$

Discussion We cannot find this temperature directly from steam tables at the end of the book. Approximating the final compressed liquid state as saturated liquid at the given internal energy, the final temperature is determined from Table A-4 to be

$$T_2 \cong T_{\text{sat}@u=467.53 \text{ kJ/kg}} = 111.5^\circ\text{C}$$

Note that this approximation resulted in an answer, which is not very close to the exact answer determined using EES.

4-113 A 1-ton (1000 kg) of water is to be cooled in a tank by pouring ice into it. The final equilibrium temperature in the tank is to be determined.

Assumptions **1** Thermal properties of the ice and water are constant. **2** Heat transfer to the water tank is negligible. **3** There is no stirring by hand or a mechanical device (it will add energy).

Properties The specific heat of water at room temperature is $c = 4.18 \text{ kJ/kg}\cdot^\circ\text{C}$, and the specific heat of ice at about 0°C is $c = 2.11 \text{ kJ/kg}\cdot^\circ\text{C}$ (Table A-3). The melting temperature and the heat of fusion of ice at 1 atm are 0°C and 333.7 kJ/kg .

Analysis We take the ice and the water as our system, and disregard any heat transfer between the system and the surroundings. Then the energy balance for this process can be written as

$$\underbrace{E_{in} - E_{out}}_{\substack{\text{Net energy transfer} \\ \text{by heat, work, and mass}}} = \underbrace{\Delta E_{\text{system}}}_{\substack{\text{Change in internal, kinetic,} \\ \text{potential, etc. energies}}}$$

$$0 = \Delta U$$

$$0 = \Delta U_{\text{ice}} + \Delta U_{\text{water}}$$

$$[mc(0^\circ\text{C} - T_1)_{\text{solid}} + mh_{if} + mc(T_2 - 0^\circ\text{C})_{\text{liquid}}]_{\text{ice}} + [mc(T_2 - T_1)]_{\text{water}} = 0$$

Substituting,

$$(80 \text{ kg})\{(2.11 \text{ kJ/kg}\cdot^\circ\text{C})[0 - (-5)]^\circ\text{C} + 333.7 \text{ kJ/kg} + (4.18 \text{ kJ/kg}\cdot^\circ\text{C})(T_2 - 0)^\circ\text{C}\}$$

$$+ (1000 \text{ kg})(4.18 \text{ kJ/kg}\cdot^\circ\text{C})(T_2 - 20)^\circ\text{C} = 0$$

It gives

$$T_2 = \mathbf{12.4^\circ\text{C}}$$

which is the final equilibrium temperature in the tank.

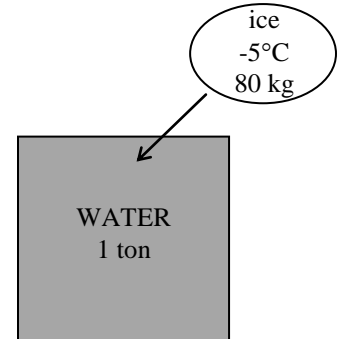

4-114 A cylinder equipped with a set of stops for the piston is initially filled with saturated liquid-vapor mixture of water a specified pressure. Heat is transferred to the water until the volume increases by 20%. The initial and final temperature, the mass of the liquid when the piston starts moving, and the work done during the process are to be determined, and the process is to be shown on a P - v diagram.

Assumptions The process is quasi-equilibrium.

Analysis (a) Initially the system is a saturated mixture at 160 kPa pressure, and thus the initial temperature is

$$T_1 = T_{\text{sat}@160\text{kPa}} = \mathbf{113.3^\circ\text{C}}$$

The total initial volume is

$$\mathcal{V}_1 = m_f \nu_f + m_g \nu_g = 1 \times 0.001054 + 2 \times 1.0915 = 2.184 \text{ m}^3$$

Then the total and specific volumes at the final state are

$$\mathcal{V}_3 = 1.2\mathcal{V}_1 = 1.2 \times 2.184 = 2.621 \text{ m}^3$$

$$\nu_3 = \frac{\mathcal{V}_3}{m} = \frac{2.621 \text{ m}^3}{3 \text{ kg}} = 0.8736 \text{ m}^3/\text{kg}$$

Thus,

$$\left. \begin{array}{l} P_3 = 500 \text{ kPa} \\ \nu_3 = 0.8736 \text{ m}^3/\text{kg} \end{array} \right\} T_3 = \mathbf{675^\circ\text{C}}$$

(b) When the piston first starts moving, $P_2 = 500 \text{ kPa}$ and $\mathcal{V}_2 = \mathcal{V}_1 = 2.184 \text{ m}^3$. The specific volume at this state is

$$\nu_2 = \frac{\mathcal{V}_2}{m} = \frac{2.184 \text{ m}^3}{3 \text{ kg}} = 0.7280 \text{ m}^3/\text{kg}$$

which is greater than $\nu_g = 0.3748 \text{ m}^3/\text{kg}$ at 500 kPa. Thus **no liquid** is left in the cylinder when the piston starts moving.

(c) No work is done during process 1-2 since $\mathcal{V}_1 = \mathcal{V}_2$. The pressure remains constant during process 2-3 and the work done during this process is

$$W_b = \int_2^3 P d\mathcal{V} = P_2 (\mathcal{V}_3 - \mathcal{V}_2) = (500 \text{ kPa})(2.621 - 2.184) \text{ m}^3 \left(\frac{1 \text{ kJ}}{1 \text{ kPa} \cdot \text{m}^3} \right) = \mathbf{218 \text{ kJ}}$$

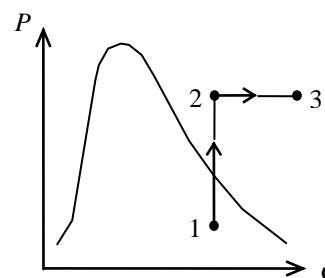
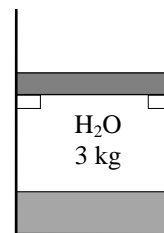

4-115 A cylinder is initially filled with saturated R-134a vapor at a specified pressure. The refrigerant is heated both electrically and by heat transfer at constant pressure for 6 min. The electric current is to be determined, and the process is to be shown on a T - ν diagram.

Assumptions 1 The cylinder is stationary and thus the kinetic and potential energy changes are negligible. **2** The thermal energy stored in the cylinder itself and the wires is negligible. **3** The compression or expansion process is quasi-equilibrium.

Analysis We take the contents of the cylinder as the system. This is a closed system since no mass enters or leaves. The energy balance for this stationary closed system can be expressed as

$$\underbrace{E_{\text{in}} - E_{\text{out}}}_{\substack{\text{Net energy transfer} \\ \text{by heat, work, and mass}}} = \underbrace{\Delta E_{\text{system}}}_{\substack{\text{Change in internal, kinetic,} \\ \text{potential, etc. energies}}}$$

$$Q_{\text{in}} + W_{\text{e,in}} - W_{\text{b,out}} = \Delta U \quad (\text{since } Q = \text{KE} = \text{PE} = 0)$$

$$Q_{\text{in}} + W_{\text{e,in}} = m(h_2 - h_1)$$

$$Q_{\text{in}} + (VI\Delta t) = m(h_2 - h_1)$$

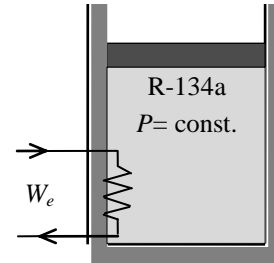

since $\Delta U + W_b = \Delta H$ during a constant pressure quasi-equilibrium process. The properties of R-134a are (Tables A-11 through A-13)

$$\left. \begin{array}{l} P_1 = 240 \text{ kPa} \\ \text{sat. vapor} \end{array} \right\} h_1 = h_{g@240\text{kPa}} = 247.32 \text{ kJ/kg}$$

$$\left. \begin{array}{l} P_2 = 240 \text{ kPa} \\ T_1 = 70^\circ\text{C} \end{array} \right\} h_2 = 314.53 \text{ kJ/kg}$$

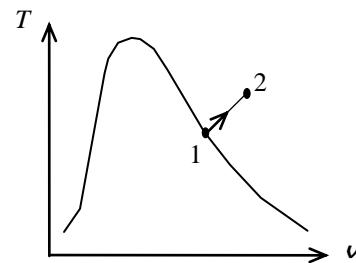

Substituting,

$$300,000 \text{ VAs} + (110 \text{ V})(I)(6 \times 60 \text{ s}) = (12 \text{ kg})(314.53 - 247.32) \text{ kJ/kg} \left(\frac{1000 \text{ VA}}{1 \text{ kJ/s}} \right)$$

$$I = 12.8 \text{ A}$$

4-116 Saturated water vapor contained in a spring-loaded piston-cylinder device is condensed until it is saturated liquid at a specified temperature. The heat transfer is to be determined.

Assumptions 1 The cylinder is stationary and thus the kinetic and potential energy changes are zero. **2** There are no work interactions involved other than the boundary work. **3** The thermal energy stored in the cylinder itself is negligible. **4** The compression or expansion process is quasi-equilibrium.

Analysis We take the contents of the cylinder as the system. This is a closed system since no mass enters or leaves. The energy balance for this stationary closed system can be expressed as

$$\underbrace{E_{\text{in}} - E_{\text{out}}}_{\substack{\text{Net energy transfer} \\ \text{by heat, work, and mass}}} = \underbrace{\Delta E_{\text{system}}}_{\substack{\text{Change in internal, kinetic,} \\ \text{potential, etc. energies}}}$$

$$W_{b,\text{in}} - Q_{\text{out}} = \Delta U = m(u_2 - u_1) \quad (\text{since KE} = \text{PE} = 0)$$

$$Q_{\text{out}} = W_{b,\text{in}} - m(u_2 - u_1)$$

$$q_{\text{out}} = w_{b,\text{in}} - (u_2 - u_1)$$

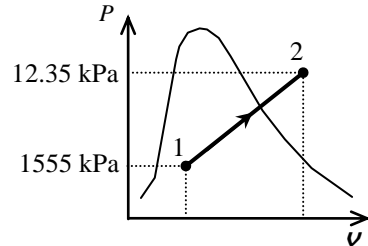

The properties at the initial and final states are (Table A-4),

$$P_1 = P_{\text{sat}@20^\circ\text{C}} = 1555 \text{ kPa}$$

$$v_1 = v_{g@20^\circ\text{C}} = 0.1272 \text{ m}^3/\text{kg}$$

$$u_1 = u_{g@20^\circ\text{C}} = 2594.2 \text{ kJ/kg}$$

$$P_2 = P_{\text{sat}@50^\circ\text{C}} = 12.35 \text{ kPa}$$

$$v_2 = v_{f@50^\circ\text{C}} = 0.001012 \text{ m}^3/\text{kg}$$

$$u_2 = u_{f@50^\circ\text{C}} = 209.33 \text{ kJ/kg}$$

Since this is a linear process, the work done is equal to the area under the process line 1-2:

$$w_{b,\text{out}} = \text{Area} = \frac{P_1 + P_2}{2} (v_2 - v_1)$$

$$= \frac{(1555 + 12.35) \text{ kPa}}{2} (0.001012 - 0.1272 \text{ m}^3/\text{kg}) \left(\frac{1 \text{ kJ}}{1 \text{ kPa} \cdot \text{m}^3} \right) = -98.9 \text{ kJ/kg}$$

Thus,

$$w_{b,\text{in}} = 98.9 \text{ kJ/kg}$$

Substituting into energy balance equation gives

$$q_{\text{out}} = w_{b,\text{in}} - (u_2 - u_1) = 98.9 \text{ kJ/kg} - (209.33 - 2594.2) \text{ kJ/kg} = \mathbf{2484 \text{ kJ/kg}}$$

4-117 The ideal gas in a piston-cylinder device is cooled at constant pressure. The gas constant and the molar mass of this gas are to be determined.

Assumptions There is no friction between piston and cylinder.

Properties The specific heat ratio is given to be 1.667

Analysis Noting that the gas constant represents the boundary work for a unit mass and a unit temperature change, the gas constant is simply determined from

$$R = \frac{W_b}{m\Delta T} = \frac{16.6 \text{ kJ}}{(0.8 \text{ kg})(10^\circ\text{C})} = \mathbf{2.075 \text{ kJ/kg}\cdot\text{K}}$$

The molar mass of the gas is

$$M = \frac{R_u}{R} = \frac{8.314 \text{ kJ/kmol}\cdot\text{K}}{2.075 \text{ kJ/kg}\cdot\text{K}} = \mathbf{4.007 \text{ kg/kmol}}$$

The specific heats are determined as

$$c_v = \frac{R}{k-1} = \frac{2.075 \text{ kJ/kg}\cdot\text{K}}{1.667-1} = \mathbf{3.111 \text{ kJ/kg}\cdot^\circ\text{C}}$$

$$c_p = c_v + R = 3.111 \text{ kJ/kg}\cdot\text{K} + 2.075 \text{ kJ/kg}\cdot\text{K} = \mathbf{5.186 \text{ kJ/kg}\cdot^\circ\text{C}}$$

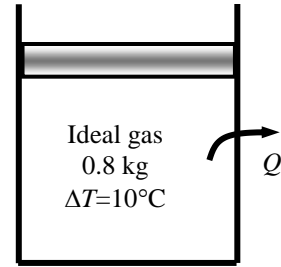

4-118 A cylinder is initially filled with helium gas at a specified state. Helium is compressed polytropically to a specified temperature and pressure. The heat transfer during the process is to be determined.

Assumptions 1 Helium is an ideal gas with constant specific heats. **2** The cylinder is stationary and thus the kinetic and potential energy changes are negligible. **3** The thermal energy stored in the cylinder itself is negligible. **4** The compression or expansion process is quasi-equilibrium.

Properties The gas constant of helium is $R = 2.0769 \text{ kPa}\cdot\text{m}^3/\text{kg}\cdot\text{K}$ (Table A-1). Also, $c_v = 3.1156 \text{ kJ/kg}\cdot\text{K}$ (Table A-2).

Analysis The mass of helium and the exponent n are determined to be

$$m = \frac{P_1 V_1}{RT_1} = \frac{(100 \text{ kPa})(0.2 \text{ m}^3)}{(2.0769 \text{ kPa}\cdot\text{m}^3/\text{kg}\cdot\text{K})(283 \text{ K})} = 0.03403 \text{ kg}$$

$$\frac{P_1 V_1}{RT_1} = \frac{P_2 V_2}{RT_2} \longrightarrow V_2 = \frac{T_2 P_1}{T_1 P_2} V_1 = \frac{563 \text{ K}}{283 \text{ K}} \times \frac{100 \text{ kPa}}{700 \text{ kPa}} \times 0.2 \text{ m}^3 = 0.05684 \text{ m}^3$$

$$P_2 V_2^n = P_1 V_1^n \longrightarrow \left(\frac{P_2}{P_1}\right) = \left(\frac{V_1}{V_2}\right)^n \longrightarrow \frac{700}{100} = \left(\frac{0.2}{0.05684}\right)^n \longrightarrow n = 1.547$$

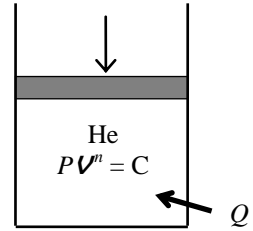

Then the boundary work for this polytropic process can be determined from

$$W_{b,\text{in}} = -\int_1^2 P dV = -\frac{P_2 V_2 - P_1 V_1}{1-n} = -\frac{mR(T_2 - T_1)}{1-n}$$

$$= -\frac{(0.03403 \text{ kg})(2.0769 \text{ kJ/kg}\cdot\text{K})(563 - 283) \text{ K}}{1-1.547} = 36.19 \text{ kJ}$$

We take the contents of the cylinder as the system. This is a closed system since no mass enters or leaves. Taking the direction of heat transfer to be to the cylinder, the energy balance for this stationary closed system can be expressed as

$$\underbrace{E_{\text{in}} - E_{\text{out}}}_{\substack{\text{Net energy transfer} \\ \text{by heat, work, and mass}}} = \underbrace{\Delta E_{\text{system}}}_{\substack{\text{Change in internal, kinetic,} \\ \text{potential, etc. energies}}}$$

$$Q_{\text{in}} + W_{b,\text{in}} = \Delta U = m(u_2 - u_1)$$

$$Q_{\text{in}} = m(u_2 - u_1) - W_{b,\text{in}}$$

$$= mc_v(T_2 - T_1) - W_{b,\text{in}}$$

Substituting,

$$Q_{\text{in}} = (0.03403 \text{ kg})(3.1156 \text{ kJ/kg}\cdot\text{K})(563 - 283) \text{ K} - (36.19 \text{ kJ}) = \mathbf{-6.51 \text{ kJ}}$$

The negative sign indicates that heat is lost from the system.

4-119 An insulated cylinder initially contains a saturated liquid-vapor mixture of water at a specified temperature. The entire vapor in the cylinder is to be condensed isothermally by adding ice inside the cylinder. The amount of ice that needs to be added is to be determined.

Assumptions 1 Thermal properties of the ice are constant. 2 The cylinder is well-insulated and thus heat transfer is negligible. 3 There is no stirring by hand or a mechanical device (it will add energy).

Properties The specific heat of ice at about 0°C is $c = 2.11$ kJ/kg·°C (Table A-3). The melting temperature and the heat of fusion of ice at 1 atm are given to be 0°C and 333.7 kJ/kg.

Analysis We take the contents of the cylinder (ice and saturated water) as our system, which is a closed system. Noting that the temperature and thus the pressure remains constant during this phase change process and thus $W_b + \Delta U = \Delta H$, the energy balance for this system can be written as

$$\underbrace{E_{\text{in}} - E_{\text{out}}}_{\text{Net energy transfer by heat, work, and mass}} = \underbrace{\Delta E_{\text{system}}}_{\text{Change in internal, kinetic, potential, etc. energies}}$$

$$W_{b,\text{in}} = \Delta U \rightarrow \Delta H = 0$$

$$\Delta H_{\text{ice}} + \Delta H_{\text{water}} = 0$$

$$[mc(0^\circ\text{C} - T_1)_{\text{solid}} + mh_{\text{if}} + mc(T_2 - 0^\circ\text{C})_{\text{liquid}}]_{\text{ice}} + [m(h_2 - h_1)]_{\text{water}} = 0$$

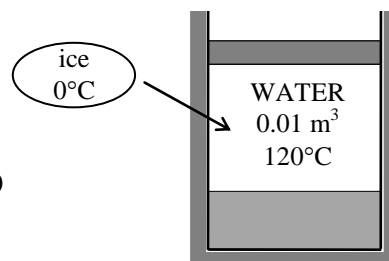

The properties of water at 120°C are (Table A-4)

$$\nu_f = 0.001060, \quad \nu_g = 0.89133 \text{ m}^3/\text{kg}$$

$$h_f = 503.81, \quad h_{fg} = 2202.1 \text{ kJ/kg}$$

Then,

$$\nu_1 = \nu_f + x_1 \nu_{fg} = 0.001060 + 0.2 \times (0.89133 - 0.001060) = 0.17911 \text{ m}^3/\text{kg}$$

$$h_1 = h_f + x_1 h_{fg} = 503.81 + 0.2 \times 2202.1 = 944.24 \text{ kJ/kg}$$

$$h_2 = h_f @ 120^\circ\text{C} = 503.81 \text{ kJ/kg}$$

$$m_{\text{steam}} = \frac{\nu_1}{\nu_1} = \frac{0.01 \text{ m}^3}{0.17911 \text{ m}^3/\text{kg}} = 0.05583 \text{ kg}$$

Noting that $T_{1,\text{ice}} = 0^\circ\text{C}$ and $T_2 = 120^\circ\text{C}$ and substituting gives

$$m[0 + 333.7 \text{ kJ/kg} + (4.18 \text{ kJ/kg}\cdot^\circ\text{C})(120-0)^\circ\text{C}] + (0.05583 \text{ kg})(503.81 - 944.24) \text{ kJ/kg} = 0$$

$$m = 0.0294 \text{ kg} = \mathbf{29.4 \text{ g ice}}$$

4-120 Nitrogen gas is expanded in a polytropic process. The work done and the heat transfer are to be determined.

Assumptions 1 Nitrogen is an ideal gas since it is at a high temperature and low pressure relative to its critical point values of 126.2 K and 3.39 MPa. **2** The kinetic and potential energy changes are negligible, $\Delta ke \cong \Delta pe \cong 0$. **3** Constant specific heats can be used.

Properties The properties of nitrogen are $R = 0.2968 \text{ kJ/kg}\cdot\text{K}$ and $c_v = 0.743 \text{ kJ/kg}\cdot\text{K}$ (Table A-2a).

Analysis We take nitrogen in the cylinder as the system. This is a *closed system* since no mass crosses the boundaries of the system. The energy balance for this system can be expressed as

$$\underbrace{E_{\text{in}} - E_{\text{out}}}_{\substack{\text{Net energy transfer} \\ \text{by heat, work, and mass}}} = \underbrace{\Delta E_{\text{system}}}_{\substack{\text{Change in internal, kinetic,} \\ \text{potential, etc. energies}}}$$

$$Q_{\text{in}} - W_{b,\text{out}} = \Delta U = mc_v(T_2 - T_1)$$

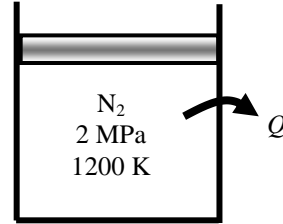

Using the boundary work relation for the polytropic process of an ideal gas gives

$$w_{b,\text{out}} = \frac{RT_1}{1-n} \left[\left(\frac{P_2}{P_1} \right)^{(n-1)/n} - 1 \right] = \frac{(0.2968 \text{ kJ/kg}\cdot\text{K})(1200 \text{ K})}{1-1.25} \left[\left(\frac{200}{2000} \right)^{0.25/1.25} - 1 \right] = \mathbf{526 \text{ kJ/kg}}$$

The temperature at the final state is

$$T_2 = T_1 \left(\frac{P_2}{P_1} \right)^{(n-1)/n} = (1200 \text{ K}) \left(\frac{200 \text{ kPa}}{2000 \text{ kPa}} \right)^{0.25/1.25} = 757.1 \text{ K}$$

Substituting into the energy balance equation,

$$q_{\text{in}} = w_{b,\text{out}} + c_v(T_2 - T_1) = 526 \text{ kJ/kg} + (0.743 \text{ kJ/kg}\cdot\text{K})(757.1 - 1200) \text{ K} = \mathbf{197 \text{ kJ/kg}}$$

4-121 The heating of a passive solar house at night is to be assisted by solar heated water. The length of time that the electric heating system would run that night with or without solar heating are to be determined.

Assumptions 1 Water is an incompressible substance with constant specific heats. **2** The energy stored in the glass containers themselves is negligible relative to the energy stored in water. **3** The house is maintained at 22°C at all times.

Properties The density and specific heat of water at room temperature are $\rho = 1 \text{ kg/L}$ and $c = 4.18 \text{ kJ/kg}\cdot^\circ\text{C}$ (Table A-3).

Analysis (a) The total mass of water is

$$m_w = \rho V = (1 \text{ kg/L})(50 \times 20 \text{ L}) = 1000 \text{ kg}$$

Taking the contents of the house, including the water as our system, the energy balance relation can be written as

$$\underbrace{E_{\text{in}} - E_{\text{out}}}_{\substack{\text{Net energy transfer} \\ \text{by heat, work, and mass}}} = \underbrace{\Delta E_{\text{system}}}_{\substack{\text{Change in internal, kinetic,} \\ \text{potential, etc. energies}}}$$

$$W_{\text{e,in}} - Q_{\text{out}} = \Delta U = (\Delta U)_{\text{water}} + (\Delta U)_{\text{air}}$$

$$= (\Delta U)_{\text{water}} = mc(T_2 - T_1)_{\text{water}}$$

or,

$$\dot{W}_{\text{e,in}} \Delta t - Q_{\text{out}} = [mc(T_2 - T_1)]_{\text{water}}$$

Substituting,

$$(15 \text{ kJ/s})\Delta t - (50,000 \text{ kJ/h})(10 \text{ h}) = (1000 \text{ kg})(4.18 \text{ kJ/kg}\cdot^\circ\text{C})(22 - 80)^\circ\text{C}$$

It gives

$$\Delta t = 17,170 \text{ s} = \mathbf{4.77 \text{ h}}$$

(b) If the house incorporated no solar heating, the energy balance relation above would simplify further to

$$\dot{W}_{\text{e,in}} \Delta t - Q_{\text{out}} = 0$$

Substituting,

$$(15 \text{ kJ/s})\Delta t - (50,000 \text{ kJ/h})(10 \text{ h}) = 0$$

It gives

$$\Delta t = 33,333 \text{ s} = \mathbf{9.26 \text{ h}}$$

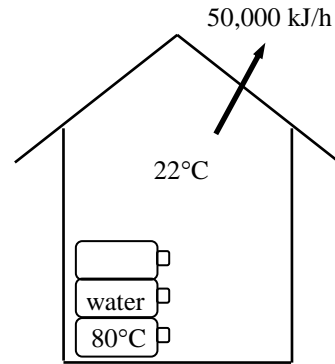

4-122 One ton of liquid water at 50°C is brought into a room. The final equilibrium temperature in the room is to be determined.

Assumptions 1 The room is well insulated and well sealed. **2** The thermal properties of water and air are constant.

Properties The gas constant of air is $R = 0.287 \text{ kPa}\cdot\text{m}^3/\text{kg}\cdot\text{K}$ (Table A-1). The specific heat of water at room temperature is $c = 4.18 \text{ kJ}/\text{kg}\cdot^\circ\text{C}$ (Table A-3).

Analysis The volume and the mass of the air in the room are

$$V = 4 \times 5 \times 6 = 120 \text{ m}^3$$

$$m_{\text{air}} = \frac{P_1 V_1}{RT_1} = \frac{(95 \text{ kPa})(120 \text{ m}^3)}{(0.2870 \text{ kPa}\cdot\text{m}^3/\text{kg}\cdot\text{K})(288 \text{ K})} = 137.9 \text{ kg}$$

Taking the contents of the room, including the water, as our system, the energy balance can be written as

$$\underbrace{E_{\text{in}} - E_{\text{out}}}_{\substack{\text{Net energy transfer} \\ \text{by heat, work, and mass}}} = \underbrace{\Delta E_{\text{system}}}_{\substack{\text{Change in internal, kinetic,} \\ \text{potential, etc. energies}}}$$

$$0 = \Delta U = (\Delta U)_{\text{water}} + (\Delta U)_{\text{air}}$$

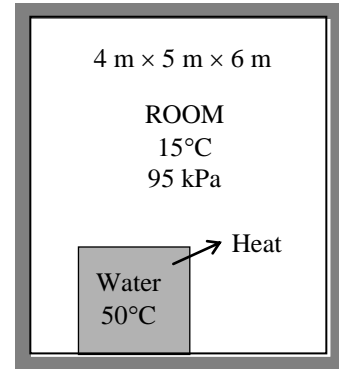

or

$$[mc(T_2 - T_1)]_{\text{water}} + [mc_v(T_2 - T_1)]_{\text{air}} = 0$$

Substituting,

$$(1000 \text{ kg})(4.18 \text{ kJ}/\text{kg}\cdot^\circ\text{C})(T_f - 50)^\circ\text{C} + (137.9 \text{ kg})(0.718 \text{ kJ}/\text{kg}\cdot^\circ\text{C})(T_f - 15)^\circ\text{C} = 0$$

It gives

$$T_f = 49.2^\circ\text{C}$$

where T_f is the final equilibrium temperature in the room.

4-123 Water is boiled at sea level (1 atm pressure) in a coffee maker, and half of the water evaporates in 25 min. The power rating of the electric heating element and the time it takes to heat the cold water to the boiling temperature are to be determined.

Assumptions 1 The electric power consumption by the heater is constant. 2 Heat losses from the coffee maker are negligible.

Properties The enthalpy of vaporization of water at the saturation temperature of 100°C is $h_{fg} = 2256.4$ kJ/kg (Table A-4). At an average temperature of $(100+18)/2 = 59^\circ\text{C}$, the specific heat of water is $c = 4.18$ kJ/kg·°C, and the density is about 1 kg/L (Table A-3).

Analysis The density of water at room temperature is very nearly 1 kg/L, and thus the mass of 1 L water at 18°C is nearly 1 kg. Noting that the enthalpy of vaporization represents the amount of energy needed to vaporize a liquid at a specified temperature, the amount of electrical energy needed to vaporize 0.5 kg of water in 25 min is

$$W_e = \dot{W}_e \Delta t = m h_{fg} \rightarrow \dot{W}_e = \frac{m h_{fg}}{\Delta t} = \frac{(0.5 \text{ kg})(2256.4 \text{ kJ/kg})}{(25 \times 60 \text{ s})} = \mathbf{0.752 \text{ kW}}$$

Therefore, the electric heater consumes (and transfers to water) 0.752 kW of electric power.

Noting that the specific heat of water at the average temperature of $(18+100)/2 = 59^\circ\text{C}$ is $c = 4.18$ kJ/kg·°C, the time it takes for the entire water to be heated from 18°C to 100°C is determined to be

$$W_e = \dot{W}_e \Delta t = m c \Delta T \rightarrow \Delta t = \frac{m c \Delta T}{\dot{W}_e} = \frac{(1 \text{ kg})(4.18 \text{ kJ/kg} \cdot ^\circ\text{C})(100 - 18)^\circ\text{C}}{0.752 \text{ kJ/s}} = 456 \text{ s} = \mathbf{7.60 \text{ min}}$$

Discussion We can also solve this problem using v_f data (instead of density), and h_f data instead of specific heat. At 100°C, we have $v_f = 0.001043$ m³/kg and $h_f = 419.17$ kJ/kg. At 18°C, we have $h_f = 75.54$ kJ/kg (Table A-4). The two results will be practically the same.

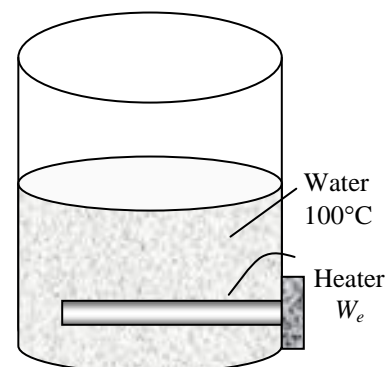

4-124 A room is to be heated by 1 ton of hot water contained in a tank placed in the room. The minimum initial temperature of the water is to be determined if it is to meet the heating requirements of this room for a 24-h period.

Assumptions 1 Water is an incompressible substance with constant specific heats. **2** Air is an ideal gas with constant specific heats. **3** The energy stored in the container itself is negligible relative to the energy stored in water. **4** The room is maintained at 20°C at all times. **5** The hot water is to meet the heating requirements of this room for a 24-h period.

Properties The specific heat of water at room temperature is $c = 4.18 \text{ kJ/kg}\cdot^\circ\text{C}$ (Table A-3).

Analysis Heat loss from the room during a 24-h period is

$$Q_{\text{loss}} = (6000 \text{ kJ/h})(24 \text{ h}) = 144,000 \text{ kJ}$$

Taking the contents of the room, including the water, as our system, the energy balance can be written as

$$\underbrace{E_{\text{in}} - E_{\text{out}}}_{\substack{\text{Net energy transfer} \\ \text{by heat, work, and mass}}} = \underbrace{\Delta E_{\text{system}}}_{\substack{\text{Change in internal, kinetic,} \\ \text{potential, etc. energies}}}$$

$$-Q_{\text{out}} = \Delta U = (\Delta U)_{\text{water}} + (\Delta U)_{\text{air}} \quad \text{?}$$

or

$$-Q_{\text{out}} = [mc(T_2 - T_1)]_{\text{water}}$$

Substituting,

$$-144,000 \text{ kJ} = (1000 \text{ kg})(4.18 \text{ kJ/kg}\cdot^\circ\text{C})(20 - T_1)$$

It gives

$$T_1 = 54.5^\circ\text{C}$$

where T_1 is the temperature of the water when it is first brought into the room.

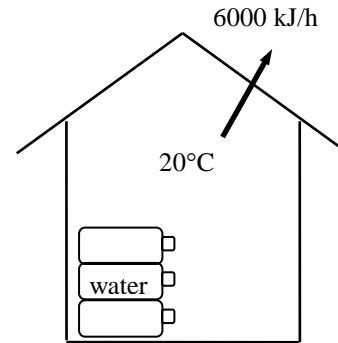

4-125 A sample of a food is burned in a bomb calorimeter, and the water temperature rises by 3.2°C when equilibrium is established. The energy content of the food is to be determined.

Assumptions 1 Water is an incompressible substance with constant specific heats. **2** Air is an ideal gas with constant specific heats. **3** The energy stored in the reaction chamber is negligible relative to the energy stored in water. **4** The energy supplied by the mixer is negligible.

Properties The specific heat of water at room temperature is $c = 4.18 \text{ kJ/kg}\cdot^\circ\text{C}$ (Table A-3). The constant volume specific heat of air at room temperature is $c_v = 0.718 \text{ kJ/kg}\cdot^\circ\text{C}$ (Table A-2).

Analysis The chemical energy released during the combustion of the sample is transferred to the water as heat. Therefore, disregarding the change in the sensible energy of the reaction chamber, the energy content of the food is simply the heat transferred to the water. Taking the water as our system, the energy balance can be written as

$$\underbrace{E_{\text{in}} - E_{\text{out}}}_{\substack{\text{Net energy transfer} \\ \text{by heat, work, and mass}}} = \underbrace{\Delta E_{\text{system}}}_{\substack{\text{Change in internal, kinetic,} \\ \text{potential, etc. energies}}} \rightarrow Q_{\text{in}} = \Delta U$$

or

$$Q_{\text{in}} = (\Delta U)_{\text{water}} = [mc(T_2 - T_1)]_{\text{water}}$$

Substituting,

$$Q_{\text{in}} = (3 \text{ kg})(4.18 \text{ kJ/kg}\cdot^\circ\text{C})(3.2^\circ\text{C}) = 40.13 \text{ kJ}$$

for a 2-g sample. Then the energy content of the food per unit mass is

$$\frac{40.13 \text{ kJ}}{2 \text{ g}} \left(\frac{1000 \text{ g}}{1 \text{ kg}} \right) = \mathbf{20,060 \text{ kJ/kg}}$$

To make a rough estimate of the error involved in neglecting the thermal energy stored in the reaction chamber, we treat the entire mass within the chamber as air and determine the change in sensible internal energy:

$$(\Delta U)_{\text{chamber}} = [mc_v(T_2 - T_1)]_{\text{chamber}} = (0.102 \text{ kg})(0.718 \text{ kJ/kg}\cdot^\circ\text{C})(3.2^\circ\text{C}) = 0.23 \text{ kJ}$$

which is less than 1% of the internal energy change of water. Therefore, it is reasonable to disregard the change in the sensible energy content of the reaction chamber in the analysis.

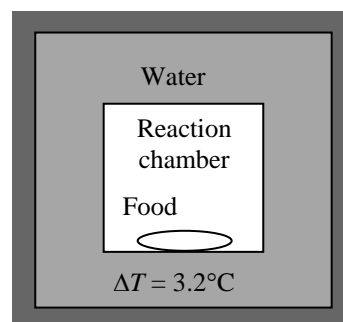

4-126 A man drinks one liter of cold water at 3°C in an effort to cool down. The drop in the average body temperature of the person under the influence of this cold water is to be determined.

Assumptions 1 Thermal properties of the body and water are constant. **2** The effect of metabolic heat generation and the heat loss from the body during that time period are negligible.

Properties The density of water is very nearly 1 kg/L, and the specific heat of water at room temperature is $c = 4.18$ kJ/kg·°C (Table A-3). The average specific heat of human body is given to be 3.6 kJ/kg·°C.

Analysis. The mass of the water is

$$m_w = \rho V = (1 \text{ kg/L})(1 \text{ L}) = 1 \text{ kg}$$

We take the man and the water as our system, and disregard any heat and mass transfer and chemical reactions. Of course these assumptions may be acceptable only for very short time periods, such as the time it takes to drink the water. Then the energy balance can be written as

$$\underbrace{E_{\text{in}} - E_{\text{out}}}_{\substack{\text{Net energy transfer} \\ \text{by heat, work, and mass}}} = \underbrace{\Delta E_{\text{system}}}_{\substack{\text{Change in internal, kinetic,} \\ \text{potential, etc. energies}}}$$

$$0 = \Delta U = \Delta U_{\text{body}} + \Delta U_{\text{water}}$$



or

$$[mc(T_2 - T_1)]_{\text{body}} + [mc(T_2 - T_1)]_{\text{water}} = 0$$

Substituting $(68 \text{ kg})(3.6 \text{ kJ/kg}\cdot^\circ\text{C})(T_f - 39)^\circ\text{C} + (1 \text{ kg})(4.18 \text{ kJ/kg}\cdot^\circ\text{C})(T_f - 3)^\circ\text{C} = 0$

It gives

$$T_f = 38.4^\circ\text{C}$$

Then

$$\Delta T = 39 - 38.4 = \mathbf{0.6^\circ\text{C}}$$

Therefore, the average body temperature of this person should drop about half a degree celsius.

4-127 An insulated rigid tank initially contains saturated liquid water and air. An electric resistor placed in the tank is turned on until the tank contains saturated water vapor. The volume of the tank, the final temperature, and the power rating of the resistor are to be determined.

Assumptions **1** The tank is stationary and thus the kinetic and potential energy changes are zero. **2** There are no work interactions. **3** Energy added to the air is neglected.

Properties The initial properties of steam are (Table A-4)

$$\left. \begin{array}{l} T_1 = 200^\circ\text{C} \\ x_1 = 0 \end{array} \right\} \begin{array}{l} v_1 = 0.001157 \text{ m}^3/\text{kg} \\ u_1 = 850.46 \text{ kJ/kg} \end{array}$$

Analysis (a) We take the contents of the tank as the system. We neglect energy added to the air in our analysis based on the problem statement. This is a closed system since no mass enters or leaves. Noting that the volume of the system is constant and thus there is no boundary work, the energy balance for this stationary closed system can be expressed as

$$\underbrace{E_{\text{in}} - E_{\text{out}}}_{\substack{\text{Net energy transfer} \\ \text{by heat, work, and mass}}} = \underbrace{\Delta E_{\text{system}}}_{\substack{\text{Change in internal, kinetic,} \\ \text{potential, etc. energies}}}$$

$$W_{\text{e,in}} = \Delta U = m(u_2 - u_1) \quad (\text{since } Q = \text{KE} = \text{PE} = 0)$$

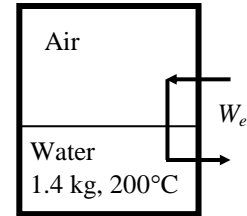

The initial water volume and the tank volume are

$$V_1 = m v_1 = (1.4 \text{ kg})(0.001157 \text{ m}^3/\text{kg}) = 0.001619 \text{ m}^3$$

$$V_{\text{tank}} = \frac{0.001619 \text{ m}^3}{0.25} = \mathbf{0.006476 \text{ m}^3}$$

(b) Now, the final state can be fixed by calculating specific volume

$$v_2 = \frac{V_2}{m} = \frac{0.006476 \text{ m}^3}{1.4 \text{ kg}} = 0.004626 \text{ m}^3/\text{kg}$$

The final state properties are

$$\left. \begin{array}{l} v_2 = 0.004626 \text{ m}^3/\text{kg} \\ x_2 = 1 \end{array} \right\} \begin{array}{l} T_2 = \mathbf{371.3^\circ\text{C}} \\ u_2 = 2201.5 \text{ kJ/kg} \end{array}$$

(c) Substituting,

$$W_{\text{e,in}} = (1.4 \text{ kg})(2201.5 - 850.46) \text{ kJ/kg} = 1892 \text{ kJ}$$

Finally, the power rating of the resistor is

$$\dot{W}_{\text{e,in}} = \frac{W_{\text{e,in}}}{\Delta t} = \frac{1892 \text{ kJ}}{20 \times 60 \text{ s}} = \mathbf{1.576 \text{ kW}}$$

4-128 A 0.3-L glass of water at 20°C is to be cooled with ice to 5°C. The amount of ice or cold water that needs to be added to the water is to be determined.

Assumptions 1 Thermal properties of the ice and water are constant. **2** Heat transfer to the glass is negligible. **3** There is no stirring by hand or a mechanical device (it will add energy).

Properties The density of water is 1 kg/L, and the specific heat of water at room temperature is $c = 4.18 \text{ kJ/kg}\cdot^\circ\text{C}$ (Table A-3). The specific heat of ice at about 0°C is $c = 2.11 \text{ kJ/kg}\cdot^\circ\text{C}$ (Table A-3). The melting temperature and the heat of fusion of ice at 1 atm are 0°C and 333.7 kJ/kg.

Analysis (a) The mass of the water is

$$m_w = \rho V = (1 \text{ kg/L})(0.3 \text{ L}) = 0.3 \text{ kg}$$

We take the ice and the water as our system, and disregard any heat and mass transfer. This is a reasonable assumption since the time period of the process is very short. Then the energy balance can be written as

$$\underbrace{E_{\text{in}} - E_{\text{out}}}_{\substack{\text{Net energy transfer} \\ \text{by heat, work, and mass}}} = \underbrace{\Delta E_{\text{system}}}_{\substack{\text{Change in internal, kinetic,} \\ \text{potential, etc. energies}}}$$

$$0 = \Delta U$$

$$0 = \Delta U_{\text{ice}} + \Delta U_{\text{water}}$$

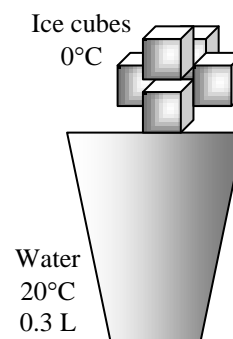

$$[mc(0^\circ\text{C} - T_1)_{\text{solid}} + mh_{\text{if}} + mc(T_2 - 0^\circ\text{C})_{\text{liquid}}]_{\text{ice}} + [mc(T_2 - T_1)]_{\text{water}} = 0$$

Noting that $T_{1,\text{ice}} = 0^\circ\text{C}$ and $T_2 = 5^\circ\text{C}$ and substituting gives

$$m[0 + 333.7 \text{ kJ/kg} + (4.18 \text{ kJ/kg}\cdot^\circ\text{C})(5 - 0)^\circ\text{C}] + (0.3 \text{ kg})(4.18 \text{ kJ/kg}\cdot^\circ\text{C})(5 - 20)^\circ\text{C} = 0$$

$$m = 0.0546 \text{ kg} = \mathbf{54.6 \text{ g}}$$

(b) When $T_{1,\text{ice}} = -20^\circ\text{C}$ instead of 0°C , substituting gives

$$m[(2.11 \text{ kJ/kg}\cdot^\circ\text{C})[0 - (-20)]^\circ\text{C} + 333.7 \text{ kJ/kg} + (4.18 \text{ kJ/kg}\cdot^\circ\text{C})(5 - 0)^\circ\text{C}]$$

$$+ (0.3 \text{ kg})(4.18 \text{ kJ/kg}\cdot^\circ\text{C})(5 - 20)^\circ\text{C} = 0$$

$$m = 0.0487 \text{ kg} = \mathbf{48.7 \text{ g}}$$

Cooling with cold water can be handled the same way. All we need to do is replace the terms for ice by a term for cold water at 0°C:

$$(\Delta U)_{\text{coldwater}} + (\Delta U)_{\text{water}} = 0$$

$$[mc(T_2 - T_1)]_{\text{coldwater}} + [mc(T_2 - T_1)]_{\text{water}} = 0$$

Substituting,

$$[m_{\text{cold water}} (4.18 \text{ kJ/kg}\cdot^\circ\text{C})(5 - 0)^\circ\text{C}] + (0.3 \text{ kg})(4.18 \text{ kJ/kg}\cdot^\circ\text{C})(5 - 20)^\circ\text{C} = 0$$

It gives

$$m = 0.9 \text{ kg} = \mathbf{900 \text{ g}}$$

Discussion Note that this is about 16 times the amount of ice needed, and it explains why we use ice instead of water to cool drinks. Also, the temperature of ice does not seem to make a significant difference.



4-129 Problem 4-128 is reconsidered. The effect of the initial temperature of the ice on the final mass of ice required as the ice temperature varies from -26°C to 0°C is to be investigated. The mass of ice is to be plotted against the initial temperature of ice.

Analysis The problem is solved using EES, and the solution is given below.

"Knowns"

$$\rho_{\text{water}} = 1 \text{ [kg/L]}$$

$$V = 0.3 \text{ [L]}$$

$$T_{1,\text{ice}} = 0 \text{ [C]}$$

$$T_1 = 20 \text{ [C]}$$

$$T_2 = 5 \text{ [C]}$$

$$C_{\text{ice}} = 2.11 \text{ [kJ/kg-C]}$$

$$C_{\text{water}} = 4.18 \text{ [kJ/kg-C]}$$

$$h_{\text{if}} = 333.7 \text{ [kJ/kg]}$$

$$T_{1,\text{ColdWater}} = 0 \text{ [C]}$$

$$m_{\text{water}} = \rho_{\text{water}} * V \text{ [kg]} \text{ "The mass of the water"}$$

"The system is the water plus the ice. Assume a short time period and neglect any heat and mass transfer. The energy balance becomes:"

$$E_{\text{in}} - E_{\text{out}} = \text{DELTA}E_{\text{sys}} \text{ [kJ]}$$

$$E_{\text{in}} = 0 \text{ [kJ]}$$

$$E_{\text{out}} = 0 \text{ [kJ]}$$

$$\text{DELTA}E_{\text{sys}} = \text{DELTA}U_{\text{water}} + \text{DELTA}U_{\text{ice}} \text{ [kJ]}$$

$$\text{DELTA}U_{\text{water}} = m_{\text{water}} * C_{\text{water}} * (T_2 - T_1) \text{ [kJ]}$$

$$\text{DELTA}U_{\text{ice}} = \text{DELTA}U_{\text{solid ice}} + \text{DELTA}U_{\text{melted ice}} \text{ [kJ]}$$

$$\text{DELTA}U_{\text{solid ice}} = m_{\text{ice}} * C_{\text{ice}} * (0 - T_{1,\text{ice}}) + m_{\text{ice}} * h_{\text{if}} \text{ [kJ]}$$

$$\text{DELTA}U_{\text{melted ice}} = m_{\text{ice}} * C_{\text{water}} * (T_2 - 0) \text{ [kJ]}$$

$$m_{\text{ice,grams}} = m_{\text{ice}} * \text{convert}(\text{kg,g}) \text{ [g]}$$

"Cooling with Cold Water:"

$$\text{DELTA}E_{\text{sys}} = \text{DELTA}U_{\text{water}} + \text{DELTA}U_{\text{ColdWater}} \text{ [kJ]}$$

$$\text{DELTA}U_{\text{water}} = m_{\text{water}} * C_{\text{water}} * (T_{2,\text{ColdWater}} - T_1) \text{ [kJ]}$$

$$\text{DELTA}U_{\text{ColdWater}} = m_{\text{ColdWater}} * C_{\text{water}} * (T_{2,\text{ColdWater}} - T_{1,\text{ColdWater}}) \text{ [kJ]}$$

$$m_{\text{ColdWater,grams}} = m_{\text{ColdWater}} * \text{convert}(\text{kg,g}) \text{ [g]}$$

$T_{1,\text{ice}}$ [C]	$m_{\text{ice,grams}}$ [g]
-26	45.94
-24	46.42
-22	46.91
-20	47.4
-18	47.91
-16	48.43
-14	48.97
-12	49.51
-10	50.07
-8	50.64
-6	51.22
-4	51.81
-2	52.42
0	53.05

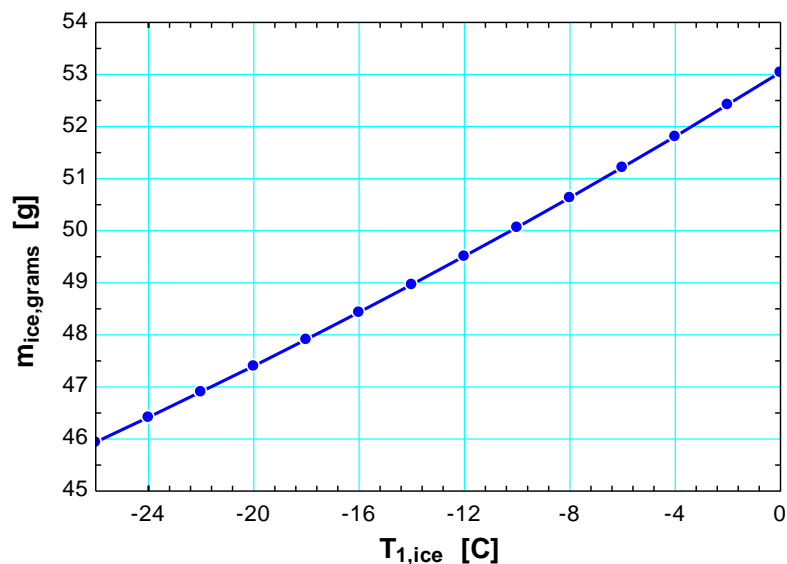

4-130 A well-insulated room is heated by a steam radiator, and the warm air is distributed by a fan. The average temperature in the room after 45 min is to be determined.

Assumptions 1 Air is an ideal gas with constant specific heats at room temperature. **2** The kinetic and potential energy changes are negligible. **3** The air pressure in the room remains constant and thus the air expands as it is heated, and some warm air escapes.

Properties The gas constant of air is $R = 0.287 \text{ kPa}\cdot\text{m}^3/\text{kg}\cdot\text{K}$ (Table A-1). Also, $c_p = 1.005 \text{ kJ/kg}\cdot\text{K}$ for air at room temperature (Table A-2).

Analysis We first take the radiator as the system. This is a closed system since no mass enters or leaves. The energy balance for this closed system can be expressed as

$$\underbrace{E_{\text{in}} - E_{\text{out}}}_{\substack{\text{Net energy transfer} \\ \text{by heat, work, and mass}}} = \underbrace{\Delta E_{\text{system}}}_{\substack{\text{Change in internal, kinetic,} \\ \text{potential, etc. energies}}}$$

$$-Q_{\text{out}} = \Delta U = m(u_2 - u_1) \quad (\text{since } W = \text{KE} = \text{PE} = 0)$$

$$Q_{\text{out}} = m(u_1 - u_2)$$

Using data from the steam tables (Tables A-4 through A-6), some properties are determined to be

$$\left. \begin{array}{l} P_1 = 200 \text{ kPa} \\ T_1 = 200^\circ\text{C} \end{array} \right\} \begin{array}{l} \nu_1 = 1.08049 \text{ m}^3/\text{kg} \\ u_1 = 2654.6 \text{ kJ/kg} \end{array}$$

$$\left. \begin{array}{l} P_2 = 100 \text{ kPa} \\ (\nu_2 = \nu_1) \end{array} \right\} \begin{array}{l} \nu_f = 0.001043, \quad \nu_g = 1.6941 \text{ m}^3/\text{kg} \\ u_f = 417.40, \quad u_{fg} = 2088.2 \text{ kJ/kg} \end{array}$$

$$x_2 = \frac{\nu_2 - \nu_f}{\nu_{fg}} = \frac{1.08049 - 0.001043}{1.6941 - 0.001043} = 0.6376$$

$$u_2 = u_f + x_2 u_{fg} = 417.40 + 0.6376 \times 2088.2 = 1748.7 \text{ kJ/kg}$$

$$m = \frac{\nu_1}{\nu_1} = \frac{0.015 \text{ m}^3}{1.08049 \text{ m}^3/\text{kg}} = 0.01388 \text{ kg}$$

Substituting, $Q_{\text{out}} = (0.01388 \text{ kg})(2654.6 - 1748.7) \text{ kJ/kg} = 12.58 \text{ kJ}$

The volume and the mass of the air in the room are $\nu = 3 \times 4 \times 6 = 72 \text{ m}^3$ and

$$m_{\text{air}} = \frac{P_1 \nu_1}{RT_1} = \frac{(100 \text{ kPa})(72 \text{ m}^3)}{(0.2870 \text{ kPa}\cdot\text{m}^3/\text{kg}\cdot\text{K})(280 \text{ K})} = 89.60 \text{ kg}$$

The amount of fan work done in 45 min is

$$W_{\text{fan, in}} = \dot{W}_{\text{fan, in}} \Delta t = (0.120 \text{ kJ/s})(45 \times 60 \text{ s}) = 324 \text{ kJ}$$

We now take the air in the room as the system. The energy balance for this closed system is expressed as

$$E_{\text{in}} - E_{\text{out}} = \Delta E_{\text{system}}$$

$$Q_{\text{in}} + W_{\text{fan, in}} - W_{\text{b, out}} = \Delta U$$

$$Q_{\text{in}} + W_{\text{fan, in}} = \Delta H \cong mc_p(T_2 - T_1)$$

since the boundary work and ΔU combine into ΔH for a constant pressure expansion or compression process. It can also be expressed as

$$(\dot{Q}_{\text{in}} + \dot{W}_{\text{fan, in}}) \Delta t = mc_{p, \text{avg}}(T_2 - T_1)$$

Substituting, $(12.58 \text{ kJ}) + (324 \text{ kJ}) = (89.60 \text{ kg})(1.005 \text{ kJ/kg}\cdot^\circ\text{C})(T_2 - 7)^\circ\text{C}$

which yields

$$T_2 = \mathbf{10.7^\circ\text{C}}$$

Therefore, the air temperature in the room rises from 7°C to 10.7°C in 45 min.

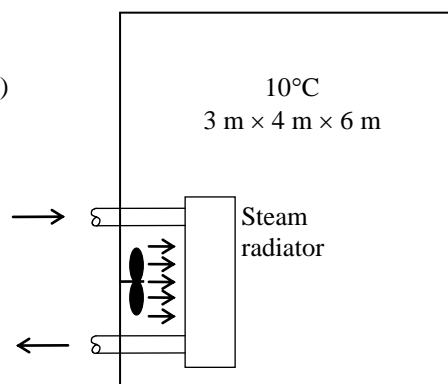

4-131 Two rigid tanks that contain water at different states are connected by a valve. The valve is opened and the two tanks come to the same state at the temperature of the surroundings. The final pressure and the amount of heat transfer are to be determined.

Assumptions 1 The tanks are stationary and thus the kinetic and potential energy changes are zero. 2 The tank is insulated and thus heat transfer is negligible. 3 There are no work interactions.

Analysis We take the entire contents of the tank as the system. This is a closed system since no mass enters or leaves. Noting that the volume of the system is constant and thus there is no boundary work, the energy balance for this stationary closed system can be expressed as

$$\underbrace{E_{\text{in}} - E_{\text{out}}}_{\substack{\text{Net energy transfer} \\ \text{by heat, work, and mass}}} = \underbrace{\Delta E_{\text{system}}}_{\substack{\text{Change in internal, kinetic,} \\ \text{potential, etc. energies}}}$$

$$-Q_{\text{out}} = \Delta U = (\Delta U)_A + (\Delta U)_B \quad (\text{since } W = \text{KE} = \text{PE} = 0)$$

$$Q_{\text{out}} = -[U_{2,A+B} - U_{1,A} - U_{1,B}]$$

$$= -[m_{2,\text{total}}u_2 - (m_1u_1)_A - (m_1u_1)_B]$$

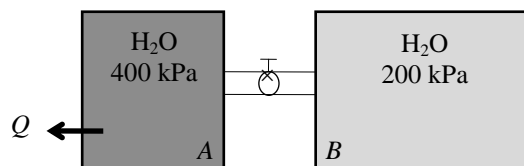

The properties of water in each tank are (Tables A-4 through A-6)

Tank A:

$$P_1 = 400 \text{ kPa} \left\{ \begin{array}{l} \nu_f = 0.001084, \quad \nu_g = 0.46242 \text{ m}^3/\text{kg} \\ x_1 = 0.80 \quad \left\{ \begin{array}{l} u_f = 604.22, \quad u_{fg} = 1948.9 \text{ kJ/kg} \end{array} \right. \end{array} \right.$$

$$\nu_{1,A} = \nu_f + x_1\nu_{fg} = 0.001084 + [0.8 \times (0.46242 - 0.001084)] = 0.37015 \text{ m}^3/\text{kg}$$

$$u_{1,A} = u_f + x_1u_{fg} = 604.22 + (0.8 \times 1948.9) = 2163.3 \text{ kJ/kg}$$

Tank B:

$$P_1 = 200 \text{ kPa} \left\{ \begin{array}{l} \nu_{1,B} = 1.1989 \text{ m}^3/\text{kg} \\ T_1 = 250^\circ\text{C} \quad \left\{ \begin{array}{l} u_{1,B} = 2731.4 \text{ kJ/kg} \end{array} \right. \end{array} \right.$$

$$m_{1,A} = \frac{\nu_A}{\nu_{1,A}} = \frac{0.2 \text{ m}^3}{0.37015 \text{ m}^3/\text{kg}} = 0.5403 \text{ kg}$$

$$m_{1,B} = \frac{\nu_B}{\nu_{1,B}} = \frac{0.5 \text{ m}^3}{1.1989 \text{ m}^3/\text{kg}} = 0.4170 \text{ kg}$$

$$m_t = m_{1,A} + m_{1,B} = 0.5403 + 0.4170 = 0.9573 \text{ kg}$$

$$\nu_2 = \frac{\nu_t}{m_t} = \frac{0.7 \text{ m}^3}{0.9573 \text{ kg}} = 0.73117 \text{ m}^3/\text{kg}$$

$$T_2 = 25^\circ\text{C} \left\{ \begin{array}{l} \nu_f = 0.001003, \quad \nu_g = 43.340 \text{ m}^3/\text{kg} \\ \nu_2 = 0.73117 \text{ m}^3/\text{kg} \quad \left\{ \begin{array}{l} u_f = 104.83, \quad u_{fg} = 2304.3 \text{ kJ/kg} \end{array} \right. \end{array} \right.$$

Thus at the final state the system will be a saturated liquid-vapor mixture since $\nu_f < \nu_2 < \nu_g$. Then the final pressure must be

$$P_2 = P_{\text{sat @ } 25^\circ\text{C}} = \mathbf{3.17 \text{ kPa}}$$

Also,

$$x_2 = \frac{\nu_2 - \nu_f}{\nu_{fg}} = \frac{0.73117 - 0.001}{43.340 - 0.001} = 0.01685$$

$$u_2 = u_f + x_2u_{fg} = 104.83 + (0.01685 \times 2304.3) = 143.65 \text{ kJ/kg}$$

Substituting, $Q_{\text{out}} = -[(0.9573)(143.65) - (0.5403)(2163.3) - (0.4170)(2731.4)] = \mathbf{2170 \text{ kJ}}$



4-132 Problem 4-131 is reconsidered. The effect of the environment temperature on the final pressure and the heat transfer as the environment temperature varies from 0°C to 50°C is to be investigated. The final results are to be plotted against the environment temperature.

Analysis The problem is solved using EES, and the solution is given below.

"Knowns"

```
Vol_A=0.2 [m^3]
P_A[1]=400 [kPa]
x_A[1]=0.8
T_B[1]=250 [C]
P_B[1]=200 [kPa]
Vol_B=0.5 [m^3]
T_final=25 [C] "T_final = T_surroundings. To do the parametric study
or to solve the problem when Q_out = 0, place this statement in {}."
{Q_out=0 [kJ]} "To determine the surroundings temperature that
makes Q_out = 0, remove the {} and resolve the problem."
```

"Solution"

"Conservation of Energy for the combined tanks:"

```
E_in-E_out=DELTA E
E_in=0
E_out=Q_out
DELTA E=m_A*(u_A[2]-u_A[1])+m_B*(u_B[2]-u_B[1])
m_A=Vol_A/v_A[1]
m_B=Vol_B/v_B[1]
Fluid$='Steam_IAPWS'
u_A[1]=INTENERGY(Fluid$,P=P_A[1], x=x_A[1])
v_A[1]=volume(Fluid$,P=P_A[1], x=x_A[1])
T_A[1]=temperature(Fluid$,P=P_A[1], x=x_A[1])
u_B[1]=INTENERGY(Fluid$,P=P_B[1],T=T_B[1])
v_B[1]=volume(Fluid$,P=P_B[1],T=T_B[1])
"At the final state the steam has uniform properties through out the entire system."
u_B[2]=u_final
u_A[2]=u_final
m_final=m_A+m_B
Vol_final=Vol_A+Vol_B
v_final=Vol_final/m_final
u_final=INTENERGY(Fluid$,T=T_final, v=v_final)
P_final=pressure(Fluid$,T=T_final, v=v_final)
```

P_{final} [kPa]	Q_{out} [kJ]	T_{final} [C]
0.6112	2300	0
0.9069	2274	5.556
1.323	2247	11.11
1.898	2218	16.67
2.681	2187	22.22
3.734	2153	27.78
5.13	2116	33.33
6.959	2075	38.89
9.325	2030	44.44
12.35	1978	50

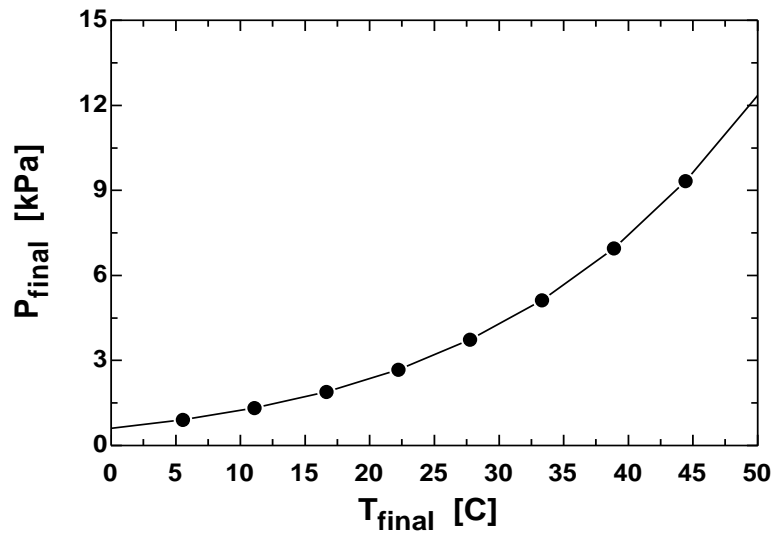
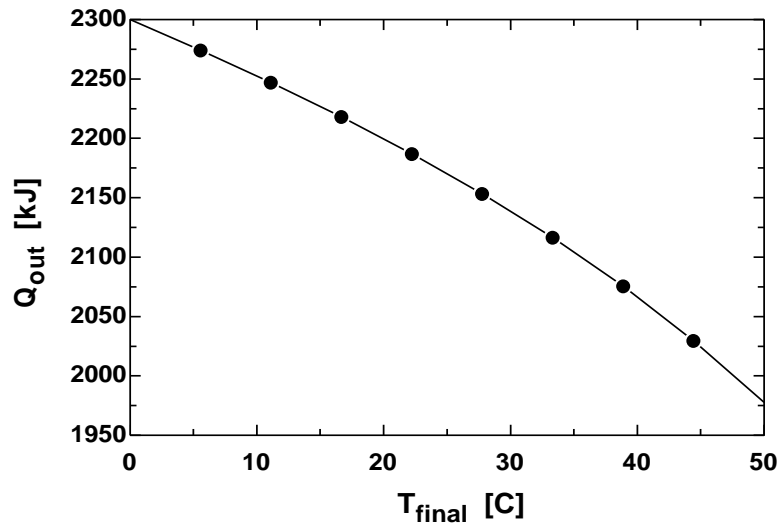

4-133 An insulated cylinder is divided into two parts. One side of the cylinder contains N_2 gas and the other side contains He gas at different states. The final equilibrium temperature in the cylinder when thermal equilibrium is established is to be determined for the cases of the piston being fixed and moving freely.

Assumptions 1 Both N_2 and He are ideal gases with constant specific heats. **2** The energy stored in the container itself is negligible. **3** The cylinder is well-insulated and thus heat transfer is negligible.

Properties The gas constants and the constant volume specific heats are $R = 0.2968 \text{ kPa}\cdot\text{m}^3/\text{kg}\cdot\text{K}$ is $c_v = 0.743 \text{ kJ/kg}\cdot^\circ\text{C}$ for N_2 , and $R = 2.0769 \text{ kPa}\cdot\text{m}^3/\text{kg}\cdot\text{K}$ is $c_v = 3.1156 \text{ kJ/kg}\cdot^\circ\text{C}$ for He (Tables A-1 and A-2)

Analysis The mass of each gas in the cylinder is

$$m_{N_2} = \left(\frac{P_1 V_1}{RT_1} \right)_{N_2} = \frac{(500 \text{ kPa})(1 \text{ m}^3)}{(0.2968 \text{ kPa}\cdot\text{m}^3/\text{kg}\cdot\text{K})(393 \text{ K})} = 4.287 \text{ kg}$$

$$m_{He} = \left(\frac{P_1 V_1}{RT_1} \right)_{He} = \frac{(500 \text{ kPa})(1 \text{ m}^3)}{(2.0769 \text{ kPa}\cdot\text{m}^3/\text{kg}\cdot\text{K})(313 \text{ K})} = 0.7691 \text{ kg}$$

N_2	He
1 m^3	1 m^3
500 kPa	500 kPa
120°C	40°C

Taking the entire contents of the cylinder as our system, the 1st law relation can be written as

$$\underbrace{E_{in} - E_{out}}_{\substack{\text{Net energy transfer} \\ \text{by heat, work, and mass}}} = \underbrace{\Delta E_{system}}_{\substack{\text{Change in internal, kinetic,} \\ \text{potential, etc. energies}}}$$

$$0 = \Delta U = (\Delta U)_{N_2} + (\Delta U)_{He}$$

$$0 = [mc_v(T_2 - T_1)]_{N_2} + [mc_v(T_2 - T_1)]_{He}$$

Substituting,

$$(4.287 \text{ kg})(0.743 \text{ kJ/kg}\cdot^\circ\text{C})(T_f - 120)^\circ\text{C} + (0.7691 \text{ kg})(3.1156 \text{ kJ/kg}\cdot^\circ\text{C})(T_f - 40)^\circ\text{C} = 0$$

It gives

$$T_f = 85.7^\circ\text{C}$$

where T_f is the final equilibrium temperature in the cylinder.

The answer would be the **same** if the piston were not free to move since it would effect only pressure, and not the specific heats.

Discussion Using the relation $PV = NR_uT$, it can be shown that the total number of moles in the cylinder is $0.153 + 0.192 = 0.345 \text{ kmol}$, and the final pressure is 515 kPa .

4-134 An insulated cylinder is divided into two parts. One side of the cylinder contains N_2 gas and the other side contains He gas at different states. The final equilibrium temperature in the cylinder when thermal equilibrium is established is to be determined for the cases of the piston being fixed and moving freely.

Assumptions 1 Both N_2 and He are ideal gases with constant specific heats. **2** The energy stored in the container itself, except the piston, is negligible. **3** The cylinder is well-insulated and thus heat transfer is negligible. **4** Initially, the piston is at the average temperature of the two gases.

Properties The gas constants and the constant volume specific heats are $R = 0.2968 \text{ kPa}\cdot\text{m}^3/\text{kg}\cdot\text{K}$ is $c_v = 0.743 \text{ kJ}/\text{kg}\cdot^\circ\text{C}$ for N_2 , and $R = 2.0769 \text{ kPa}\cdot\text{m}^3/\text{kg}\cdot\text{K}$ is $c_v = 3.1156 \text{ kJ}/\text{kg}\cdot^\circ\text{C}$ for He (Tables A-1 and A-2). The specific heat of copper piston is $c = 0.386 \text{ kJ}/\text{kg}\cdot^\circ\text{C}$ (Table A-3).

Analysis The mass of each gas in the cylinder is

$$m_{N_2} = \left(\frac{P_1 V_1}{RT_1} \right)_{N_2} = \frac{(500 \text{ kPa})(1 \text{ m}^3)}{(0.2968 \text{ kPa}\cdot\text{m}^3/\text{kg}\cdot\text{K})(393 \text{ K})} = 4.287 \text{ kg}$$

$$m_{He} = \left(\frac{P_1 V_1}{RT_1} \right)_{He} = \frac{(500 \text{ kPa})(1 \text{ m}^3)}{(2.0769 \text{ kPa}\cdot\text{m}^3/\text{kg}\cdot\text{K})(313 \text{ K})} = 0.7691 \text{ kg}$$

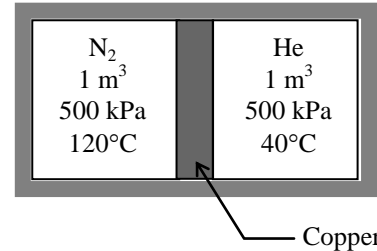

Taking the entire contents of the cylinder as our system, the 1st law relation can be written as

$$\underbrace{E_{in} - E_{out}}_{\substack{\text{Net energy transfer} \\ \text{by heat, work, and mass}}} = \underbrace{\Delta E_{system}}_{\substack{\text{Change in internal, kinetic,} \\ \text{potential, etc. energies}}}$$

$$0 = \Delta U = (\Delta U)_{N_2} + (\Delta U)_{He} + (\Delta U)_{Cu}$$

$$0 = [mc_v(T_2 - T_1)]_{N_2} + [mc_v(T_2 - T_1)]_{He} + [mc(T_2 - T_1)]_{Cu}$$

where

$$T_{1, Cu} = (120 + 40) / 2 = 80^\circ\text{C}$$

Substituting,

$$(4.287 \text{ kg})(0.743 \text{ kJ}/\text{kg}\cdot^\circ\text{C})(T_f - 120)^\circ\text{C} + (0.7691 \text{ kg})(3.1156 \text{ kJ}/\text{kg}\cdot^\circ\text{C})(T_f - 40)^\circ\text{C} \\ + (8 \text{ kg})(0.386 \text{ kJ}/\text{kg}\cdot^\circ\text{C})(T_f - 80)^\circ\text{C} = 0$$

It gives

$$T_f = 83.7^\circ\text{C}$$

where T_f is the final equilibrium temperature in the cylinder.

The answer would be the **same** if the piston were not free to move since it would effect only pressure, and not the specific heats.



4-135 Problem 4-134 is reconsidered. The effect of the mass of the copper piston on the final equilibrium temperature as the mass of piston varies from 1 kg to 10 kg is to be investigated. The final temperature is to be plotted against the mass of piston.

Analysis The problem is solved using EES, and the solution is given below.

"Knowns:"

$R_u=8.314$ [kJ/kmol-K]
 $V_{N2[1]}=1$ [m³]
 $Cv_{N2}=0.743$ [kJ/kg-K] "From Table A-2(a) at 27C"
 $R_{N2}=0.2968$ [kJ/kg-K] "From Table A-2(a)"
 $T_{N2[1]}=120$ [C]
 $P_{N2[1]}=500$ [kPa]
 $V_{He[1]}=1$ [m³]
 $Cv_{He}=3.1156$ [kJ/kg-K] "From Table A-2(a) at 27C"
 $T_{He[1]}=40$ [C]
 $P_{He[1]}=500$ [kPa]
 $R_{He}=2.0769$ [kJ/kg-K] "From Table A-2(a)"
 $m_{Pist}=8$ [kg]
 $Cv_{Pist}=0.386$ [kJ/kg-K] "Use Cp for Copper from Table A-3(b) at 27C"

"Solution:"

"mass calculations:"

$P_{N2[1]}*V_{N2[1]}=m_{N2}*R_{N2}*(T_{N2[1]}+273)$
 $P_{He[1]}*V_{He[1]}=m_{He}*R_{He}*(T_{He[1]}+273)$

"The entire cylinder is considered to be a closed system, neglecting the piston."

"Conservation of Energy for the closed system:"

" $E_{in} - E_{out} = \Delta E_{negPist}$, we neglect ΔKE and ΔPE for the cylinder."

$E_{in} - E_{out} = \Delta E_{negPist}$
 $E_{in} = 0$ [kJ]
 $E_{out} = 0$ [kJ]

"At the final equilibrium state, N2 and He will have a common temperature."

$\Delta E_{negPist} = m_{N2}*Cv_{N2}*(T_{2_negIPist}-T_{N2[1]})+m_{He}*Cv_{He}*(T_{2_negIPist}-T_{He[1]})$

"The entire cylinder is considered to be a closed system, including the piston."

"Conservation of Energy for the closed system:"

" $E_{in} - E_{out} = \Delta E_{withPist}$, we neglect ΔKE and ΔPE for the cylinder."

$E_{in} - E_{out} = \Delta E_{withPist}$

"At the final equilibrium state, N2 and He will have a common temperature."

$\Delta E_{withPist} = m_{N2}*Cv_{N2}*(T_{2_withPist}-T_{N2[1]})+m_{He}*Cv_{He}*(T_{2_withPist}-T_{He[1]})+m_{Pist}*Cv_{Pist}*(T_{2_withPist}-T_{Pist[1]})$

$T_{Pist[1]}=(T_{N2[1]}+T_{He[1]})/2$

"Total volume of gases:"

$V_{total}=V_{N2[1]}+V_{He[1]}$

"Final pressure at equilibrium:"

"Neglecting effect of piston, P_2 is:"

$P_{2_negIPist}*V_{total}=N_{total}*R_u*(T_{2_negIPist}+273)$

"Including effect of piston, P_2 is:"

$N_{total}=m_{N2}/\text{molarmass}(\text{nitrogen})+m_{He}/\text{molarmass}(\text{Helium})$

$P_{2_withPist}*V_{total}=N_{total}*R_u*(T_{2_withPist}+273)$

m_{Pist} [kg]	$T_{2,\text{neglPist}}$ [C]	$T_{2,\text{withPist}}$ [C]
1	85.65	85.29
2	85.65	84.96
3	85.65	84.68
4	85.65	84.43
5	85.65	84.2
6	85.65	83.99
7	85.65	83.81
8	85.65	83.64
9	85.65	83.48
10	85.65	83.34

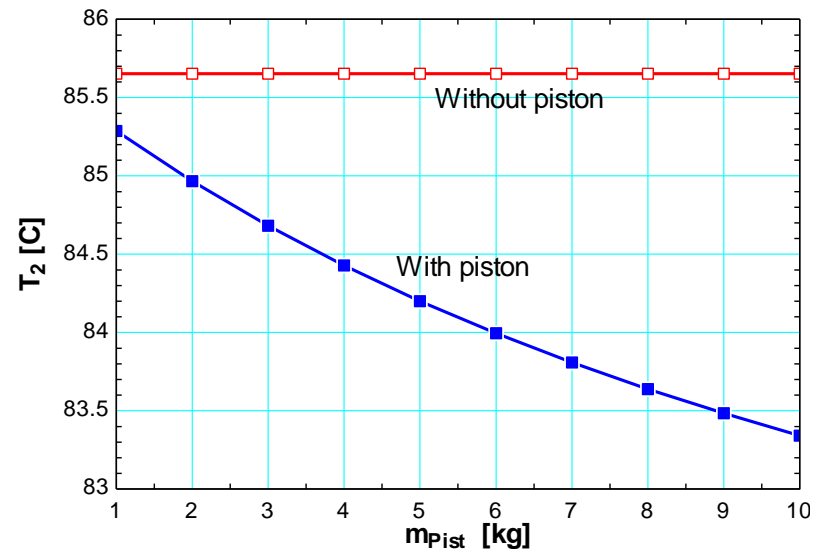

4-136 A piston-cylinder device initially contains saturated liquid water. An electric resistor placed in the tank is turned on until the tank contains saturated water vapor. The volume of the tank, the final temperature, and the power rating of the resistor are to be determined.

Assumptions 1 The cylinder is stationary and thus the kinetic and potential energy changes are zero. **2** There are no work interactions.

Properties The initial properties of steam are (Table A-4)

$$T_1 = 120^\circ\text{C} \left. \begin{array}{l} \nu_1 = 0.001060 \text{ m}^3/\text{kg} \\ h_1 = 503.81 \text{ kJ/kg} \\ P_1 = 198.67 \text{ kPa} \end{array} \right\} x_1 = 0$$

Analysis (a) We take the contents of the cylinder as the system. This is a closed system since no mass enters or leaves. Noting that the volume of the system is constant and thus there is no boundary work, the energy balance for this stationary closed system can be expressed as

$$\underbrace{E_{\text{in}} - E_{\text{out}}}_{\substack{\text{Net energy transfer} \\ \text{by heat, work, and mass}}} = \underbrace{\Delta E_{\text{system}}}_{\substack{\text{Change in internal, kinetic,} \\ \text{potential, etc. energies}}}$$

$$W_{e,\text{in}} - W_{b,\text{out}} = \Delta U = m(u_2 - u_1) \quad (\text{since } Q = \text{KE} = \text{PE} = 0)$$

$$W_{e,\text{in}} = W_{b,\text{out}} + \Delta U = \Delta H = m(h_2 - h_1)$$

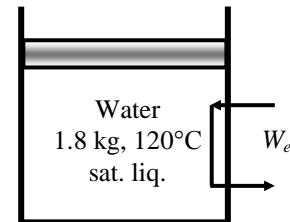

since

$$W_{b,\text{out}} + \Delta U = \Delta H \quad \text{for a constant-pressure process.}$$

The initial and final volumes are

$$\nu_1 = m\nu_1 = (1.8 \text{ kg})(0.001060 \text{ m}^3/\text{kg}) = 0.001909 \text{ m}^3$$

$$\nu_2 = 4(0.001909 \text{ m}^3) = \mathbf{0.007634 \text{ m}^3}$$

(b) Now, the final state can be fixed by calculating specific volume

$$\nu_2 = \frac{\nu_2}{m} = \frac{0.007634 \text{ m}^3}{1.8 \text{ kg}} = 0.004241 \text{ m}^3/\text{kg}$$

The final state is saturated mixture and both pressure and temperature remain constant during the process. Other properties are

$$\left. \begin{array}{l} P_2 = P_1 = 198.67 \text{ kPa} \\ \nu_2 = 0.004241 \text{ m}^3/\text{kg} \end{array} \right\} \begin{array}{l} T_2 = T_1 = \mathbf{120^\circ\text{C}} \\ h_2 = 511.68 \text{ kJ/kg} \\ x_2 = 0.00357 \end{array} \quad (\text{Table A-4 or EES})$$

(c) Substituting,

$$W_{e,\text{in}} = (1.8 \text{ kg})(511.68 - 503.81) \text{ kJ/kg} = 14.16 \text{ kJ}$$

Finally, the power rating of the resistor is

$$\dot{W}_{e,\text{in}} = \frac{W_{e,\text{in}}}{\Delta t} = \frac{14.16 \text{ kJ}}{10 \times 60 \text{ s}} = \mathbf{0.0236 \text{ kW}}$$

4-137 A piston-cylinder device contains an ideal gas. An external shaft connected to the piston exerts a force. For an isothermal process of the ideal gas, the amount of heat transfer, the final pressure, and the distance that the piston is displaced are to be determined.

Assumptions 1 The kinetic and potential energy changes are negligible, $\Delta ke \cong \Delta pe \cong 0$. **2** The friction between the piston and the cylinder is negligible.

Analysis (a) We take the ideal gas in the cylinder to be the system. This is a closed system since no mass crosses the system boundary. The energy balance for this stationary closed system can be expressed as

$$\underbrace{E_{\text{in}} - E_{\text{out}}}_{\text{Net energy transfer by heat, work, and mass}} = \underbrace{\Delta E_{\text{system}}}_{\text{Change in internal, kinetic, potential, etc. energies}}$$

$$W_{\text{b,in}} - Q_{\text{out}} = \Delta U_{\text{ideal gas}} \cong mc_v(T_2 - T_1)_{\text{ideal gas}} = 0 \quad (\text{since } T_2 = T_1 \text{ and } KE = PE = 0)$$

$$W_{\text{b,in}} = Q_{\text{out}}$$

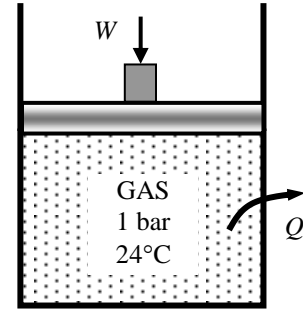

Thus, the amount of heat transfer is equal to the boundary work input

$$Q_{\text{out}} = W_{\text{b,in}} = \mathbf{0.1 \text{ kJ}}$$

(b) The relation for the isothermal work of an ideal gas may be used to determine the final volume in the cylinder. But we first calculate initial volume

$$V_1 = \frac{\pi D^2}{4} L_1 = \frac{\pi (0.12 \text{ m})^2}{4} (0.2 \text{ m}) = 0.002262 \text{ m}^3$$

Then,

$$W_{\text{b,in}} = -P_1 V_1 \ln\left(\frac{V_2}{V_1}\right)$$

$$0.1 \text{ kJ} = -(100 \text{ kPa})(0.002262 \text{ m}^3) \ln\left(\frac{V_2}{0.002262 \text{ m}^3}\right) \longrightarrow V_2 = 0.001454 \text{ m}^3$$

The final pressure can be determined from ideal gas relation applied for an isothermal process

$$P_1 V_1 = P_2 V_2 \longrightarrow (100 \text{ kPa})(0.002262 \text{ m}^3) = P_2 (0.001454 \text{ m}^3) \longrightarrow P_2 = \mathbf{155.6 \text{ kPa}}$$

(c) The final position of the piston and the distance that the piston is displaced are

$$V_2 = \frac{\pi D^2}{4} L_2 \longrightarrow 0.001454 \text{ m}^3 = \frac{\pi (0.12 \text{ m})^2}{4} L_2 \longrightarrow L_2 = 0.1285 \text{ m}$$

$$\Delta L = L_1 - L_2 = 0.20 - 0.1285 = 0.07146 \text{ m} = \mathbf{7.1 \text{ cm}}$$

4-138 A piston-cylinder device contains an ideal gas. An external shaft connected to the piston exerts a force. For an isothermal process of the ideal gas, the amount of heat transfer, the final pressure, and the distance that the piston is displaced are to be determined.

Assumptions 1 The kinetic and potential energy changes are negligible, $\Delta ke \cong \Delta pe \cong 0$. **2** The friction between the piston and the cylinder is negligible.

Analysis (a) We take the ideal gas in the cylinder to be the system. This is a closed system since no mass crosses the system boundary. The energy balance for this stationary closed system can be expressed as

$$\underbrace{E_{\text{in}} - E_{\text{out}}}_{\text{Net energy transfer by heat, work, and mass}} = \underbrace{\Delta E_{\text{system}}}_{\text{Change in internal, kinetic, potential, etc. energies}}$$

$$W_{\text{b,in}} - Q_{\text{out}} = \Delta U_{\text{ideal gas}} \cong mc_v(T_2 - T_1)_{\text{ideal gas}} = 0 \quad (\text{since } T_2 = T_1 \text{ and } KE = PE = 0)$$

$$W_{\text{b,in}} = Q_{\text{out}}$$

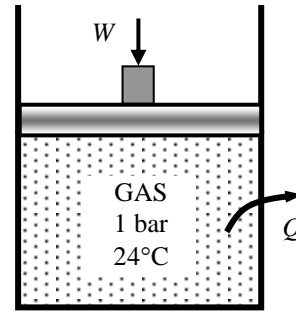

Thus, the amount of heat transfer is equal to the boundary work input

$$Q_{\text{out}} = W_{\text{b,in}} = \mathbf{0.1 \text{ kJ}}$$

(b) The relation for the isothermal work of an ideal gas may be used to determine the final volume in the cylinder. But we first calculate initial volume

$$V_1 = \frac{\pi D^2}{4} L_1 = \frac{\pi (0.12 \text{ m})^2}{4} (0.2 \text{ m}) = 0.002262 \text{ m}^3$$

Then,

$$W_{\text{b,in}} = -P_1 V_1 \ln\left(\frac{V_2}{V_1}\right)$$

$$0.1 \text{ kJ} = -(100 \text{ kPa})(0.002262 \text{ m}^3) \ln\left(\frac{V_2}{0.002262 \text{ m}^3}\right) \longrightarrow V_2 = 0.001454 \text{ m}^3$$

The final pressure can be determined from ideal gas relation applied for an isothermal process

$$P_1 V_1 = P_2 V_2 \longrightarrow (100 \text{ kPa})(0.002262 \text{ m}^3) = P_2 (0.001454 \text{ m}^3) \longrightarrow P_2 = \mathbf{155.6 \text{ kPa}}$$

(c) The final position of the piston and the distance that the piston is displaced are

$$V_2 = \frac{\pi D^2}{4} L_2 \longrightarrow 0.001454 \text{ m}^3 = \frac{\pi (0.12 \text{ m})^2}{4} L_2 \longrightarrow L_2 = 0.1285 \text{ m}$$

$$\Delta L = L_1 - L_2 = 0.20 - 0.1285 = 0.07146 \text{ m} = \mathbf{7.1 \text{ cm}}$$

4-139 A piston-cylinder device with a set of stops contains superheated steam. Heat is lost from the steam. The pressure and quality (if mixture), the boundary work, and the heat transfer until the piston first hits the stops and the total heat transfer are to be determined.

Assumptions 1 The kinetic and potential energy changes are negligible, $\Delta ke \cong \Delta pe \cong 0$. **2** The friction between the piston and the cylinder is negligible.

Analysis (a) We take the steam in the cylinder to be the system. This is a closed system since no mass crosses the system boundary. The energy balance for this stationary closed system can be expressed as

$$\underbrace{E_{in} - E_{out}}_{\text{Net energy transfer by heat, work, and mass}} = \underbrace{\Delta E_{system}}_{\text{Change in internal, kinetic, potential, etc. energies}}$$

$$W_{b,in} - Q_{out} = \Delta U \quad (\text{since } KE = PE = 0)$$

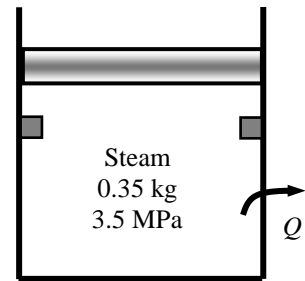

Denoting when piston first hits the stops as state (2) and the final state as (3), the energy balance relations may be written as

$$W_{b,in} - Q_{out,12} = m(u_2 - u_1)$$

$$W_{b,in} - Q_{out,13} = m(u_3 - u_1)$$

The properties of steam at various states are (Tables A-4 through A-6)

$$T_{sat@3.5\text{MPa}} = 242.56^\circ\text{C}$$

$$T_1 = T_1 + \Delta T_{sat} = 242.56 + 7.4 = 250^\circ\text{C}$$

$$P_1 = 3.5\text{ MPa} \left\{ \begin{array}{l} v_1 = 0.05875\text{ m}^3/\text{kg} \\ u_1 = 2623.9\text{ kJ/kg} \end{array} \right.$$

$$P_2 = P_1 = 3.5\text{ MPa} \left\{ \begin{array}{l} v_2 = 0.001235\text{ m}^3/\text{kg} \\ u_2 = 1045.4\text{ kJ/kg} \end{array} \right.$$

$$x_2 = 0$$

$$v_3 = v_2 = 0.001235\text{ m}^3/\text{kg} \left\{ \begin{array}{l} x_3 = \mathbf{0.00062} \\ P_3 = \mathbf{1555\text{kPa}} \\ u_3 = 851.55\text{ kJ/kg} \end{array} \right.$$

$$T_3 = 200^\circ\text{C}$$

(b) Noting that the pressure is constant until the piston hits the stops during which the boundary work is done, it can be determined from its definition as

$$W_{b,in} = mP_1(v_1 - v_2) = (0.35\text{ kg})(3500\text{ kPa})(0.05875 - 0.001235)\text{m}^3 = \mathbf{70.45\text{kJ}}$$

(c) Substituting into energy balance relations,

$$Q_{out,12} = 70.45\text{ kJ} - (0.35\text{ kg})(1045.4 - 2623.9)\text{kJ/kg} = \mathbf{622.9\text{kJ}}$$

$$(d) \quad Q_{out,13} = 70.45\text{ kJ} - (0.35\text{ kg})(851.55 - 2623.9)\text{kJ/kg} = \mathbf{690.8\text{kJ}}$$

4-140 An insulated rigid tank is divided into two compartments, each compartment containing the same ideal gas at different states. The two gases are allowed to mix. The simplest expression for the mixture temperature in a specified format is to be obtained.

Analysis We take the both compartments together as the system. This is a closed system since no mass enters or leaves. The energy balance for this stationary closed system can be expressed as

$$\underbrace{E_{\text{in}} - E_{\text{out}}}_{\substack{\text{Net energy transfer} \\ \text{by heat, work, and mass}}} = \underbrace{\Delta E_{\text{system}}}_{\substack{\text{Change in internal, kinetic,} \\ \text{potential, etc. energies}}}$$

$$0 = \Delta U \quad (\text{since } Q = W = \text{KE} = \text{PE} = 0)$$

$$0 = m_1 c_v (T_3 - T_1) + m_2 c_v (T_3 - T_2)$$

$$(m_1 + m_2) T_3 = m_1 T_1 + m_2 T_2$$

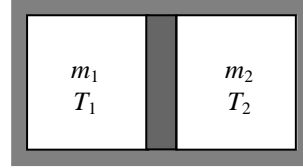

and $m_3 = m_1 + m_2$

Solving for final temperature, we find

$$T_3 = \frac{m_1}{m_3} T_1 + \frac{m_2}{m_3} T_2$$

4-141 Carbon dioxide contained in a spring-loaded piston-cylinder device is compressed in a polytropic process. The final temperature is to be determined using the compressibility factor.

Properties The gas constant, the critical pressure, and the critical temperature of CO₂ are, from Table A-1,

$$R = 0.1889 \text{ kPa} \cdot \text{m}^3/\text{kg} \cdot \text{K}, \quad T_{\text{cr}} = 304.2 \text{ K}, \quad P_{\text{cr}} = 7.39 \text{ MPa}$$

Analysis From the compressibility chart at the initial state (Fig. A-15 or EES, we used EES),

$$\left. \begin{aligned} T_{R1} &= \frac{T_1}{T_{\text{cr}}} = \frac{473 \text{ K}}{304.2 \text{ K}} = 1.55 \\ P_{R1} &= \frac{P_1}{P_{\text{cr}}} = \frac{0.5 \text{ MPa}}{7.39 \text{ MPa}} = 0.0677 \end{aligned} \right\} Z_1 = 0.9953$$

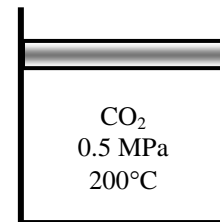

The specific volume at the initial state is

$$\nu_1 = \nu_2 = \frac{Z_1 R T_1}{P_1} = \frac{(0.9953)(0.1889 \text{ kPa} \cdot \text{m}^3/\text{kg} \cdot \text{K})(473 \text{ K})}{500 \text{ kPa}} = 0.1779 \text{ m}^3/\text{kg}$$

The specific volume at the final state can be determined from the polytropic process to be

$$P_1 \nu_1^n = P_2 \nu_2^n \longrightarrow (500 \text{ kPa})(0.1779 \text{ m}^3/\text{kg})^{1.3} = (3000 \text{ kPa}) \nu_2^{1.3} \longrightarrow \nu_2 = 0.04483 \text{ m}^3/\text{kg}$$

At the final state,

$$\left. \begin{aligned} P_{R2} &= \frac{P_2}{P_{\text{cr}}} = \frac{3 \text{ MPa}}{7.39 \text{ MPa}} = 0.406 \\ \nu_{R2} &= \frac{\nu_{2,\text{actual}}}{R T_{\text{cr}}/P_{\text{cr}}} = \frac{0.04483 \text{ m}^3/\text{kg}}{(0.1889 \text{ kPa} \cdot \text{m}^3/\text{kg} \cdot \text{K})(304.2 \text{ K})/(7390 \text{ kPa})} = 5.76 \end{aligned} \right\} Z_2 = 1.0$$

Thus,

$$T_2 = \frac{P_2 \nu_2}{Z_2 R} = \frac{(3000 \text{ kPa})(0.04483 \text{ m}^3/\text{kg})}{(1.0)(0.1889 \text{ kPa} \cdot \text{m}^3/\text{kg} \cdot \text{K})} = 712 \text{ K} = \mathbf{439^\circ\text{C}}$$

4-142 Solar energy is to be stored as sensible heat using phase-change materials, granite rocks, and water. The amount of heat that can be stored in a $5\text{-m}^3 = 5000\text{ L}$ space using these materials as the storage medium is to be determined.

Assumptions **1** The materials have constant properties at the specified values. **2** No allowance is made for voids, and thus the values calculated are the upper limits.

Analysis The amount of energy stored in a medium is simply equal to the increase in its internal energy, which, for incompressible substances, can be determined from $\Delta U = mc(T_2 - T_1)$.

(a) The latent heat of glaubers salts is given to be 329 kJ/L . Disregarding the sensible heat storage in this case, the amount of energy stored is becomes

$$\Delta U_{\text{salt}} = mh_{\text{if}} = (5000\text{ L})(329\text{ kJ/L}) = \mathbf{1,645,000\text{ kJ}}$$

This value would be even larger if the sensible heat storage due to temperature rise is considered.

(b) The density of granite is 2700 kg/m^3 (Table A-3), and its specific heat is given to be $c = 2.32\text{ kJ/kg}\cdot^\circ\text{C}$. Then the amount of energy that can be stored in the rocks when the temperature rises by 20°C becomes

$$\Delta U_{\text{rock}} = \rho V c \Delta T = (2700\text{ kg/m}^3)(5\text{ m}^3)(2.32\text{ kJ/kg}\cdot^\circ\text{C})(20^\circ\text{C}) = \mathbf{626,400\text{ kJ}}$$

(c) The density of water is about 1000 kg/m^3 (Table A-3), and its specific heat is given to be $c = 4.0\text{ kJ/kg}\cdot^\circ\text{C}$. Then the amount of energy that can be stored in the water when the temperature rises by 20°C becomes

$$\Delta U_{\text{rock}} = \rho V c \Delta T = (1000\text{ kg/m}^3)(5\text{ m}^3)(4.0\text{ kJ/kg}\cdot^\circ\text{C})(20^\circ\text{C}) = \mathbf{400,00\text{ kJ}}$$

Discussion Note that the greatest amount of heat can be stored in phase-change materials essentially at constant temperature. Such materials are not without problems, however, and thus they are not widely used.

4-143 The cylinder of a steam engine initially contains saturated vapor of water at 100 kPa. The cylinder is cooled by pouring cold water outside of it, and some of the steam inside condenses. If the piston is stuck at its initial position, the friction force acting on the piston and the amount of heat transfer are to be determined.

Assumptions The device is air-tight so that no air leaks into the cylinder as the pressure drops.

Analysis We take the contents of the cylinder (the saturated liquid-vapor mixture) as the system, which is a closed system. Noting that the volume remains constant during this phase change process, the energy balance for this system can be expressed as

$$\underbrace{E_{\text{in}} - E_{\text{out}}}_{\text{Net energy transfer by heat, work, and mass}} = \underbrace{\Delta E_{\text{system}}}_{\text{Change in internal, kinetic, potential, etc. energies}}$$

$$-Q_{\text{out}} = \Delta U = m(u_2 - u_1)$$

The saturation properties of water at 100 kPa and at 30°C are (Tables A-4 and A-5)

$$P_1 = 100 \text{ kPa} \longrightarrow \begin{aligned} \nu_f &= 0.001043 \text{ m}^3/\text{kg}, & \nu_g &= 1.6941 \text{ m}^3/\text{kg} \\ u_f &= 417.40 \text{ kJ/kg}, & u_g &= 2505.6 \text{ kJ/kg} \end{aligned}$$

$$T_2 = 30^\circ \text{C} \longrightarrow \begin{aligned} \nu_f &= 0.001004 \text{ m}^3/\text{kg}, & \nu_g &= 32.879 \text{ m}^3/\text{kg} \\ u_f &= 125.73 \text{ kJ/kg}, & u_{fg} &= 2290.2 \text{ kJ/kg} \\ P_{\text{sat}} &= 4.2469 \text{ kPa} \end{aligned}$$

Then,

$$\begin{aligned} P_2 &= P_{\text{sat}@30^\circ \text{C}} = 4.2469 \text{ kPa} \\ \nu_1 &= \nu_g @ 100 \text{ kPa} = 1.6941 \text{ m}^3/\text{kg} \\ u_1 &= u_g @ 100 \text{ kPa} = 2505.6 \text{ kJ/kg} \end{aligned}$$

and

$$\begin{aligned} m &= \frac{\nu_1}{\nu_1} = \frac{0.05 \text{ m}^3}{1.6941 \text{ m}^3/\text{kg}} = 0.02951 \text{ kg} \\ \nu_2 &= \nu_1 \longrightarrow x_2 = \frac{\nu_2 - \nu_f}{\nu_{fg}} = \frac{1.6941 - 0.001}{32.879 - 0.001} = 0.05150 \\ u_2 &= u_f + x_2 u_{fg} = 125.73 + 0.05150 \times 2290.2 = 243.67 \text{ kJ/kg} \end{aligned}$$

The friction force that develops at the piston-cylinder interface balances the force acting on the piston, and is equal to

$$F = A(P_1 - P_2) = (0.1 \text{ m}^2)(100 - 4.2469) \text{ kPa} \left(\frac{1000 \text{ N/m}^2}{1 \text{ kPa}} \right) = \mathbf{9575 \text{ N}}$$

The heat transfer is determined from the energy balance to be

$$\begin{aligned} Q_{\text{out}} &= m(u_1 - u_2) \\ &= (0.02951 \text{ kg})(2505.6 - 243.67) \text{ kJ/kg} \\ &= \mathbf{66.8 \text{ kJ}} \end{aligned}$$

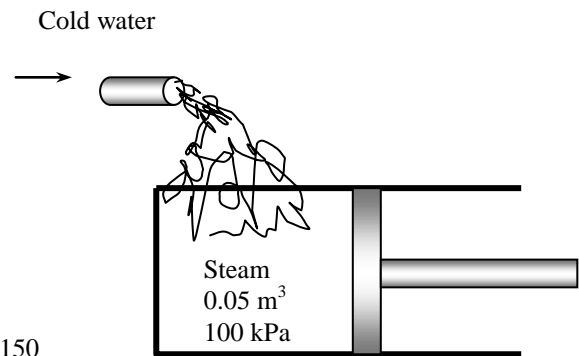

Fundamentals of Engineering (FE) Exam Problems

4-144 The specific heat of a material is given in a strange unit to be $C = 3.60 \text{ kJ/kg}\cdot^\circ\text{F}$. The specific heat of this material in the SI units of $\text{kJ/kg}\cdot^\circ\text{C}$ is

- (a) $2.00 \text{ kJ/kg}\cdot^\circ\text{C}$ (b) $3.20 \text{ kJ/kg}\cdot^\circ\text{C}$ (c) $3.60 \text{ kJ/kg}\cdot^\circ\text{C}$ (d) $4.80 \text{ kJ/kg}\cdot^\circ\text{C}$ (e) $6.48 \text{ kJ/kg}\cdot^\circ\text{C}$

Answer (e) $6.48 \text{ kJ/kg}\cdot^\circ\text{C}$

Solution Solved by EES Software. Solutions can be verified by copying-and-pasting the following lines on a blank EES screen. (Similar problems and their solutions can be obtained easily by modifying numerical values).

```
C=3.60 "kJ/kg.F"
C_SI=C*1.8 "kJ/kg.C"
"Some Wrong Solutions with Common Mistakes:"
W1_C=C "Assuming they are the same"
W2_C=C/1.8 "Dividing by 1.8 instead of multiplying"
```

4-145 A 3-m^3 rigid tank contains nitrogen gas at 500 kPa and 300 K . Now heat is transferred to the nitrogen in the tank and the pressure of nitrogen rises to 800 kPa . The work done during this process is

- (a) 500 kJ (b) 1500 kJ (c) 0 kJ (d) 900 kJ (e) 2400 kJ

Answer (b) 0 kJ

Solution Solved by EES Software. Solutions can be verified by copying-and-pasting the following lines on a blank EES screen. (Similar problems and their solutions can be obtained easily by modifying numerical values).

```
V=3 "m^3"
P1=500 "kPa"
T1=300 "K"
P2=800 "kPa"
W=0 "since constant volume"
"Some Wrong Solutions with Common Mistakes:"
R=0.297
W1_W=V*(P2-P1) "Using W=V*DELTA P"
W2_W=V*P1
W3_W=V*P2
W4_W=R*T1*ln(P1/P2)
```

4-146 A 0.5-m^3 cylinder contains nitrogen gas at 600 kPa and 300 K. Now the gas is compressed isothermally to a volume of 0.1 m^3 . The work done on the gas during this compression process is

- (a) 720 kJ (b) 483 kJ (c) 240 kJ (d) 175 kJ (e) 143 kJ

Answer (b) 483 kJ

Solution Solved by EES Software. Solutions can be verified by copying-and-pasting the following lines on a blank EES screen. (Similar problems and their solutions can be obtained easily by modifying numerical values).

```
R=8.314/28
V1=0.5 "m^3"
V2=0.1 "m^3"
P1=600 "kPa"
T1=300 "K"
P1*V1=m*R*T1
W=m*R*T1*ln(V2/V1) "constant temperature"
"Some Wrong Solutions with Common Mistakes:"
W1_W=R*T1*ln(V2/V1) "Forgetting m"
W2_W=P1*(V1-V2) "Using V*DeltaP"
P1*V1/T1=P2*V2/T1
W3_W=(V1-V2)*(P1+P2)/2 "Using P_ave*Delta V"
W4_W=P1*V1-P2*V2 "Using W=P1V1-P2V2"
```

4-147 A well-sealed room contains 60 kg of air at 200 kPa and 25°C . Now solar energy enters the room at an average rate of 0.8 kJ/s while a 120-W fan is turned on to circulate the air in the room. If heat transfer through the walls is negligible, the air temperature in the room in 30 min will be

- (a) 25.6°C (b) 49.8°C (c) 53.4°C (d) 52.5°C (e) 63.4°C

Answer (e) 63.4°C

Solution Solved by EES Software. Solutions can be verified by copying-and-pasting the following lines on a blank EES screen. (Similar problems and their solutions can be obtained easily by modifying numerical values).

```
R=0.287 "kJ/kg.K"
Cv=0.718 "kJ/kg.K"
m=60 "kg"
P1=200 "kPa"
T1=25 "C"
Qsol=0.8 "kJ/s"
time=30*60 "s"
Wfan=0.12 "kJ/s"
"Applying energy balance E_in-E_out=dE_system gives"
time*(Wfan+Qsol)=m*Cv*(T2-T1)
"Some Wrong Solutions with Common Mistakes:"
Cp=1.005 "kJ/kg.K"
time*(Wfan+Qsol)=m*Cp*(W1_T2-T1) "Using Cp instead of Cv "
time*(-Wfan+Qsol)=m*Cv*(W2_T2-T1) "Subtracting Wfan instead of adding"
time*Qsol=m*Cv*(W3_T2-T1) "Ignoring Wfan"
time*(Wfan+Qsol)/60=m*Cv*(W4_T2-T1) "Using min for time instead of s"
```

4-148 A 2-kW baseboard electric resistance heater in a vacant room is turned on and kept on for 15 min. The mass of the air in the room is 75 kg, and the room is tightly sealed so that no air can leak in or out. The temperature rise of air at the end of 15 min is

- (a) 8.5°C (b) 12.4°C (c) 24.0°C (d) 33.4°C (e) 54.8°C

Answer (d) 33.4°C

Solution Solved by EES Software. Solutions can be verified by copying-and-pasting the following lines on a blank EES screen. (Similar problems and their solutions can be obtained easily by modifying numerical values).

```
R=0.287 "kJ/kg.K"
Cv=0.718 "kJ/kg.K"
m=75 "kg"
time=15*60 "s"
W_e=2 "kJ/s"
"Applying energy balance E_in-E_out=dE_system gives"
time*W_e=m*Cv*DELTA_T "kJ"
"Some Wrong Solutions with Common Mistakes:"
Cp=1.005 "kJ/kg.K"
time*W_e=m*Cp*W1_DELTAT "Using Cp instead of Cv"
time*W_e/60=m*Cv*W2_DELTAT "Using min for time instead of s"
```

4-149 A room contains 75 kg of air at 100 kPa and 15°C. The room has a 250-W refrigerator (the refrigerator consumes 250 W of electricity when running), a 120-W TV, a 1.8-kW electric resistance heater, and a 50-W fan. During a cold winter day, it is observed that the refrigerator, the TV, the fan, and the electric resistance heater are running continuously but the air temperature in the room remains constant. The rate of heat loss from the room that day is

- (a) 5832 kJ/h (b) 6192 kJ/h (c) 7560 kJ/h (d) 7632 kJ/h (e) 7992 kJ/h

Answer (e) 7992 kJ/h

Solution Solved by EES Software. Solutions can be verified by copying-and-pasting the following lines on a blank EES screen. (Similar problems and their solutions can be obtained easily by modifying numerical values).

```
R=0.287 "kJ/kg.K"
Cv=0.718 "kJ/kg.K"
m=75 "kg"
P_1=100 "kPa"
T_1=15 "C"
time=30*60 "s"
W_ref=0.250 "kJ/s"
W_TV=0.120 "kJ/s"
W_heater=1.8 "kJ/s"
W_fan=0.05 "kJ/s"
"Applying energy balance E_in-E_out=dE_system gives E_out=E_in since T=constant and dE=0"
E_gain=W_ref+W_TV+W_heater+W_fan
Q_loss=E_gain*3600 "kJ/h"
"Some Wrong Solutions with Common Mistakes:"
E_gain1=-W_ref+W_TV+W_heater+W_fan "Subtracting Wrefrig instead of adding"
W1_Qloss=E_gain1*3600 "kJ/h"
E_gain2=W_ref+W_TV+W_heater-W_fan "Subtracting Wfan instead of adding"
W2_Qloss=E_gain2*3600 "kJ/h"
E_gain3=-W_ref+W_TV+W_heater-W_fan "Subtracting Wrefrig and Wfan instead of adding"
W3_Qloss=E_gain3*3600 "kJ/h"
E_gain4=W_ref+W_heater+W_fan "Ignoring the TV"
W4_Qloss=E_gain4*3600 "kJ/h"
```

4-150 A piston-cylinder device contains 5 kg of air at 400 kPa and 30°C. During a quasi-equilibrium isothermal expansion process, 15 kJ of boundary work is done by the system, and 3 kJ of paddle-wheel work is done on the system. The heat transfer during this process is

- (a) 12 kJ (b) 18 kJ (c) 2.4 kJ (d) 3.5 kJ (e) 60 kJ

Answer (a) 12 kJ

Solution Solved by EES Software. Solutions can be verified by copying-and-pasting the following lines on a blank EES screen. (Similar problems and their solutions can be obtained easily by modifying numerical values).

```
R=0.287 "kJ/kg.K"
Cv=0.718 "kJ/kg.K"
m=5 "kg"
P_1=400 "kPa"
T=30 "C"
Wout_b=15 "kJ"
Win_pw=3 "kJ"
"Noting that T=constant and thus dE_system=0, applying energy balance E_in-E_out=dE_system gives"
Q_in+Win_pw-Wout_b=0
"Some Wrong Solutions with Common Mistakes:"
W1_Qin=Q_in/Cv "Dividing by Cv"
W2_Qin=Win_pw+Wout_b "Adding both quantities"
W3_Qin=Win_pw "Setting it equal to paddle-wheel work"
W4_Qin=Wout_b "Setting it equal to boundaru work"
```

4-151 A 6-pack canned drink is to be cooled from 18°C to 3°C. The mass of each canned drink is 0.355 kg. The drinks can be treated as water, and the energy stored in the aluminum can itself is negligible. The amount of heat transfer from the 6 canned drinks is

- (a) 22 kJ (b) 32 kJ (c) 134 kJ (d) 187 kJ (e) 223 kJ

Answer (c) 134 kJ

Solution Solved by EES Software. Solutions can be verified by copying-and-pasting the following lines on a blank EES screen. (Similar problems and their solutions can be obtained easily by modifying numerical values).

```
c=4.18 "kJ/kg.K"
m=6*0.355 "kg"
T1=18 "C"
T2=3 "C"
DELTAT=T2-T1 "C"
"Applying energy balance E_in-E_out=dE_system and noting that dU_system=m*C*DELTAT gives"
-Q_out=m*C*DELTAT "kJ"
"Some Wrong Solutions with Common Mistakes:"
-W1_Qout=m*C*DELTAT/6 "Using one can only"
-W2_Qout=m*C*(T1+T2) "Adding temperatures instead of subtracting"
-W3_Qout=m*1.0*DELTAT "Using specific heat of air or forgetting specific heat"
```

4-152 A glass of water with a mass of 0.45 kg at 20°C is to be cooled to 0°C by dropping ice cubes at 0°C into it. The latent heat of fusion of ice is 334 kJ/kg, and the specific heat of water is 4.18 kJ/kg·°C. The amount of ice that needs to be added is

- (a) 56 g (b) 113 g (c) 124 g (d) 224 g (e) 450 g

Answer (b) 113 g

Solution Solved by EES Software. Solutions can be verified by copying-and-pasting the following lines on a blank EES screen. (Similar problems and their solutions can be obtained easily by modifying numerical values).

$C=4.18$ "kJ/kg.K"

$h_{\text{melting}}=334$ "kJ/kg.K"

$m_w=0.45$ "kg"

$T_1=20$ "C"

$T_2=0$ "C"

$\text{DELTA}T=T_2-T_1$ "C"

"Noting that there is no energy transfer with the surroundings and the latent heat of melting of ice is transferred from the water, and applying energy balance $E_{\text{in}}-E_{\text{out}}=dE_{\text{system}}$ to ice+water gives"

$dE_{\text{ice}}+dE_w=0$

$dE_{\text{ice}}=m_{\text{ice}}*h_{\text{melting}}$

$dE_w=m_w*C*\text{DELTA}T$ "kJ"

"Some Wrong Solutions with Common Mistakes:"

$W1_{\text{mice}}*h_{\text{melting}}*(T_1-T_2)+m_w*C*\text{DELTA}T=0$ "Multiplying h_{latent} by temperature difference"

$W2_{\text{mice}}=m_w$ "taking mass of water to be equal to the mass of ice"

4-153 A 2-kW electric resistance heater submerged in 5-kg water is turned on and kept on for 10 min. During the process, 300 kJ of heat is lost from the water. The temperature rise of water is

- (a) 0.4°C (b) 43.1°C (c) 57.4°C (d) 71.8°C (e) 180.0°C

Answer (b) 43.1°C

Solution Solved by EES Software. Solutions can be verified by copying-and-pasting the following lines on a blank EES screen. (Similar problems and their solutions can be obtained easily by modifying numerical values).

$C=4.18$ "kJ/kg.K"

$m=5$ "kg"

$Q_{\text{loss}}=300$ "kJ"

$\text{time}=10*60$ "s"

$W_e=2$ "kJ/s"

"Applying energy balance $E_{\text{in}}-E_{\text{out}}=dE_{\text{system}}$ gives"

$\text{time}*W_e-Q_{\text{loss}} = dU_{\text{system}}$

$dU_{\text{system}}=m*C*\text{DELTA}T$ "kJ"

"Some Wrong Solutions with Common Mistakes:"

$\text{time}*W_e = m*C*W1_T$ "Ignoring heat loss"

$\text{time}*W_e+Q_{\text{loss}} = m*C*W2_T$ "Adding heat loss instead of subtracting"

$\text{time}*W_e-Q_{\text{loss}} = m*1.0*W3_T$ "Using specific heat of air or not using specific heat"

4-154 1.5 kg of liquid water initially at 12°C is to be heated to 95°C in a teapot equipped with a 800 W electric heating element inside. The specific heat of water can be taken to be 4.18 kJ/kg.°C, and the heat loss from the water during heating can be neglected. The time it takes to heat the water to the desired temperature is

- (a) 5.9 min (b) 7.3 min (c) 10.8 min (d) 14.0 min (e) 17.0 min

Answer (c) 10.8 min

Solution Solved by EES Software. Solutions can be verified by copying-and-pasting the following lines on a blank EES screen. (Similar problems and their solutions can be obtained easily by modifying numerical values).

$C=4.18$ "kJ/kg.K"

$m=1.5$ "kg"

$T1=12$ "C"

$T2=95$ "C"

$Q_{loss}=0$ "kJ"

$W_e=0.8$ "kJ/s"

"Applying energy balance $E_{in}-E_{out}=dE_{system}$ gives"

$(time*60)*W_e-Q_{loss} = dU_{system}$ "time in minutes"

$dU_{system}=m*C*(T2-T1)$ "kJ"

"Some Wrong Solutions with Common Mistakes:"

$W1_{time*60}*W_e-Q_{loss} = m*C*(T2+T1)$ "Adding temperatures instead of subtracting"

$W2_{time*60}*W_e-Q_{loss} = C*(T2-T1)$ "Not using mass"

4-155 An ordinary egg with a mass of 0.1 kg and a specific heat of 3.32 kJ/kg.°C is dropped into boiling water at 95°C. If the initial temperature of the egg is 5°C, the maximum amount of heat transfer to the egg is

- (a) 12 kJ (b) 30 kJ (c) 24 kJ (d) 18 kJ (e) infinity

Answer (b) 30 kJ

Solution Solved by EES Software. Solutions can be verified by copying-and-pasting the following lines on a blank EES screen. (Similar problems and their solutions can be obtained easily by modifying numerical values).

$C=3.32$ "kJ/kg.K"

$m=0.1$ "kg"

$T1=5$ "C"

$T2=95$ "C"

"Applying energy balance $E_{in}-E_{out}=dE_{system}$ gives"

$E_{in} = dU_{system}$

$dU_{system}=m*C*(T2-T1)$ "kJ"

"Some Wrong Solutions with Common Mistakes:"

$W1_{Ein} = m*C*T2$ "Using T2 only"

$W2_{Ein}=m*(ENTHALPY(Steam_IAPWS,T=T2,x=1)-ENTHALPY(Steam_IAPWS,T=T2,x=0))$ "Using h_{fg} "

4-156 An apple with an average mass of 0.18 kg and average specific heat of 3.65 kJ/kg·°C is cooled from 22°C to 5°C. The amount of heat transferred from the apple is

- (a) 0.85 kJ (b) 62.1 kJ (c) 17.7 kJ (d) 11.2 kJ (e) 7.1 kJ

Answer (d) 11.2 kJ

Solution Solved by EES Software. Solutions can be verified by copying-and-pasting the following lines on a blank EES screen. (Similar problems and their solutions can be obtained easily by modifying numerical values).

```
C=3.65 "kJ/kg.K"
m=0.18 "kg"
T1=22 "C"
T2=5 "C"
"Applying energy balance E_in-E_out=dE_system gives"
-Q_out = dU_system
dU_system=m*C*(T2-T1) "kJ"
"Some Wrong Solutions with Common Mistakes:"
-W1_Qout =C*(T2-T1) "Not using mass"
-W2_Qout =m*C*(T2+T1) "adding temperatures"
```

4-157 The specific heat at constant volume for an ideal gas is given by $c_v = 0.7 + (2.7 \times 10^{-4})T$ (kJ/kg · K) where T is in kelvin. The change in the enthalpy for this ideal gas undergoing a process in which the temperature changes from 27 to 127°C is most nearly

- (a) 70 kJ/kg (b) 72.1 kJ/kg (c) 79.5 kJ/kg (d) 82.1 kJ/kg (e) 84.0 kJ/kg

Answer (c) 79.5 kJ/kg

Solution Solved by EES Software. Solutions can be verified by copying-and-pasting the following lines on a blank EES screen. (Similar problems and their solutions can be obtained easily by modifying numerical values).

```
T1=(27+273) [K]
T2=(127+273) [K]
"Performing the necessary integration, we obtain"
DELTAh=0.7*(T2-T1)+2.7E-4/2*(T2^2-T1^2)
```

4-158 An ideal gas has a gas constant $R = 0.3 \text{ kJ/kg}\cdot\text{K}$ and a constant-volume specific heat $c_v = 0.7 \text{ kJ/kg}\cdot\text{K}$. If the gas has a temperature change of 100°C , choose the correct answer for each of the following:

1. The change in enthalpy is, in kJ/kg

- (a) 30 (b) 70 (c) 100 (d) insufficient information to determine

Answer (c) 100

2. The change in internal energy is, in kJ/kg

- (a) 30 (b) 70 (c) 100 (d) insufficient information to determine

Answer (b) 70

3. The work done is, in kJ/kg

- (a) 30 (b) 70 (c) 100 (d) insufficient information to determine

Answer (d) insufficient information to determine

4. The heat transfer is, in kJ/kg

- (a) 30 (b) 70 (c) 100 (d) insufficient information to determine

Answer (d) insufficient information to determine

5. The change in the pressure-volume product is, in kJ/kg

- (a) 30 (b) 70 (c) 100 (d) insufficient information to determine

Answer (a) 30

Solution Solved by EES Software. Solutions can be verified by copying-and-pasting the following lines on a blank EES screen. (Similar problems and their solutions can be obtained easily by modifying numerical values).

```
R=0.3 [kJ/kg-K]
c_v=0.7 [kJ/kg-K]
DELTAT=100 [K]
(1)
c_p=R+c_v
DELTAh=c_p*DELTAT
(2)
DELTAu=c_v*DELTAT
(5)
PV=R*DELTAT
```

4-159 An ideal gas undergoes a constant temperature (isothermal) process in a closed system. The heat transfer and work are, respectively

- (a) $0, -c_v\Delta T$ (b) $c_v\Delta T, 0$ (c) $c_p\Delta T, R\Delta T$ (d) $R \ln(T_2/T_1), R \ln(T_2/T_1)$

Answer (d) $R \ln(T_2/T_1), R \ln(T_2/T_1)$

4-160 An ideal gas under goes a constant volume (isochoric) process in a closed system. The heat transfer and work are, respectively

- (a) $0, -c_v\Delta T$ (b) $c_v\Delta T, 0$ (c) $c_p\Delta T, R\Delta T$ (d) $R \ln(T_2/T_1), R \ln(T_2/T_1)$

Answer (b) $c_v\Delta T, 0$

4-161 An ideal gas under goes a constant pressure (isobaric) process in a closed system. The heat transfer and work are, respectively

- (a) $0, -c_v\Delta T$ (b) $c_v\Delta T, 0$ (c) $c_p\Delta T, R\Delta T$ (d) $R \ln(T_2/T_1), R \ln(T_2/T_1)$

Answer (c) $c_p\Delta T, R\Delta T$

4-162 ... 4-167 Design and Essay Problems

4-165 A claim that fruits and vegetables are cooled by 6°C for each percentage point of weight loss as moisture during vacuum cooling is to be evaluated.

Analysis Assuming the fruits and vegetables are cooled from 30°C and 0°C , the average heat of vaporization can be taken to be 2466 kJ/kg , which is the value at 15°C , and the specific heat of products can be taken to be $4 \text{ kJ/kg}\cdot^\circ\text{C}$. Then the vaporization of 0.01 kg water will lower the temperature of 1 kg of produce by $24.66/4 = 6^\circ\text{C}$. Therefore, the vacuum cooled products will lose 1 percent moisture for each 6°C drop in temperature. Thus the claim is **reasonable**.



Solutions Manual for
Thermodynamics: An Engineering Approach
8th Edition
Yunus A. Cengel, Michael A. Boles
McGraw-Hill, 2015

Chapter 5
MASS AND ENERGY ANALYSIS OF
CONTROL VOLUMES

PROPRIETARY AND CONFIDENTIAL

This Manual is the proprietary property of McGraw-Hill Education and protected by copyright and other state and federal laws. By opening and using this Manual the user agrees to the following restrictions, and if the recipient does not agree to these restrictions, the Manual should be promptly returned unopened to McGraw-Hill Education: **This Manual is being provided only to authorized professors and instructors for use in preparing for the classes using the affiliated textbook. No other use or distribution of this Manual is permitted. This Manual may not be sold and may not be distributed to or used by any student or other third party. No part of this Manual may be reproduced, displayed or distributed in any form or by any means, electronic or otherwise, without the prior written permission of McGraw-Hill Education.**

Conservation of Mass

5-1C Flow through a control volume is steady when it involves no changes with time at any specified position.

5-2C Mass flow rate is the amount of mass flowing through a cross-section per unit time whereas the volume flow rate is the amount of volume flowing through a cross-section per unit time.

5-3C The amount of mass or energy entering a control volume does not have to be equal to the amount of mass or energy leaving during an unsteady-flow process.

5-4C No, a flow with the same volume flow rate at the inlet and the exit is not necessarily steady (unless the density is constant). To be steady, the mass flow rate through the device must remain constant.

5-5 The ventilating fan of the bathroom of a building runs continuously. The mass of air “vented out” per day is to be determined.

Assumptions Flow through the fan is steady.

Properties The density of air in the building is given to be 1.20 kg/m^3 .

Analysis The mass flow rate of air vented out is

$$\dot{m}_{\text{air}} = \rho \dot{V}_{\text{air}} = (1.20 \text{ kg/m}^3)(0.030 \text{ m}^3/\text{s}) = 0.036 \text{ kg/s}$$

Then the mass of air vented out in 24 h becomes

$$m = \dot{m}_{\text{air}} \Delta t = (0.036 \text{ kg/s})(24 \times 3600 \text{ s}) = \mathbf{3110 \text{ kg}}$$

Discussion Note that more than 3 tons of air is vented out by a bathroom fan in one day.

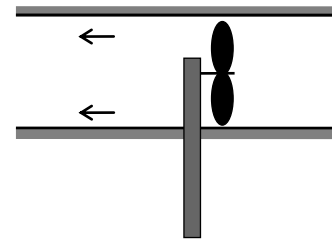

5-6E The ducts of an air-conditioning system pass through an open area. The inlet velocity and the mass flow rate of air are to be determined.

Assumptions Flow through the air conditioning duct is steady.

Properties The density of air is given to be 0.078 lbm/ft^3 at the inlet.

Analysis The inlet velocity of air and the mass flow rate through the duct are

$$V_1 = \frac{\dot{V}_1}{A_1} = \frac{\dot{V}_1}{\pi D^2 / 4} = \frac{450 \text{ ft}^3/\text{min}}{\pi(10/12 \text{ ft})^2 / 4} = \mathbf{825 \text{ ft/min} = 13.8 \text{ ft/s}}$$

$$\dot{m} = \rho_1 \dot{V}_1 = (0.078 \text{ lbm/ft}^3)(450 \text{ ft}^3/\text{min}) = 35.1 \text{ lbm/min} = \mathbf{0.585 \text{ lbm/s}}$$

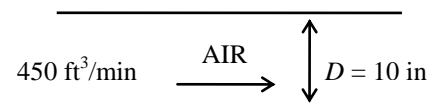

5-7 Air flows through a pipe. Heat is supplied to the air. The volume flow rates of air at the inlet and exit, the velocity at the exit, and the mass flow rate are to be determined.

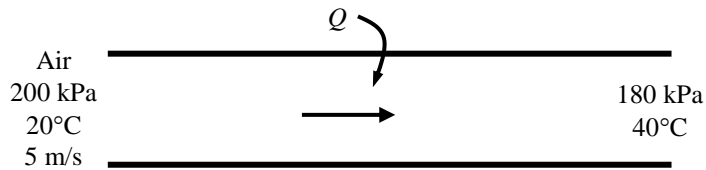

Properties The gas constant for air is 0.287 kJ/kg.K (Table A-2).

Analysis (a) (b) The volume flow rate at the inlet and the mass flow rate are

$$\dot{V}_1 = A_c V_1 = \frac{\pi D^2}{4} V_1 = \frac{\pi(0.28 \text{ m})^2}{4} (5 \text{ m/s}) = \mathbf{0.3079 \text{ m}^3/\text{s}}$$

$$\dot{m} = \rho_1 A_c V_1 = \frac{P_1}{RT_1} \frac{\pi D^2}{4} V_1 = \frac{(200 \text{ kPa})}{(0.287 \text{ kJ/kg}\cdot\text{K})(20 + 273 \text{ K})} \frac{\pi(0.28 \text{ m})^2}{4} (5 \text{ m/s}) = \mathbf{0.7318 \text{ kg/s}}$$

(c) Noting that mass flow rate is constant, the volume flow rate and the velocity at the exit of the pipe are determined from

$$\dot{V}_2 = \frac{\dot{m}}{\rho_2} = \frac{\dot{m}}{\frac{P_2}{RT_2}} = \frac{0.7318 \text{ kg/s}}{(180 \text{ kPa}) / (0.287 \text{ kJ/kg}\cdot\text{K})(40 + 273 \text{ K})} = \mathbf{0.3654 \text{ m}^3/\text{s}}$$

$$V_2 = \frac{\dot{V}_2}{A_c} = \frac{0.3654 \text{ m}^3/\text{s}}{\frac{\pi(0.28 \text{ m})^2}{4}} = \mathbf{5.94 \text{ m/s}}$$

5-8E Helium at a specified state is compressed to another specified state. The mass flow rate and the inlet area are to be determined.

Assumptions Flow through the compressor is steady.

Properties The gas constant of helium is $R = 2.6809 \text{ psia}\cdot\text{ft}^3/\text{lbm}\cdot\text{R}$ (Table A-1E)

Analysis The mass flow rate is determined from

$$\dot{m} = \frac{A_2 V_2}{\nu_2} = \frac{A_2 V_2 P_2}{RT_2} = \frac{(0.01 \text{ ft}^2)(100 \text{ ft/s})(200 \text{ psia})}{(2.6809 \text{ psia}\cdot\text{ft}^3/\text{lbm}\cdot\text{R})(1060 \text{ R})} = \mathbf{0.07038 \text{ lbm/s}}$$

The inlet area is determined from

$$A_1 = \frac{\dot{m} \nu_1}{V_1} = \frac{\dot{m} R T_1}{V_1 P_1} = \frac{(0.07038 \text{ lbm/s})(2.6809 \text{ psia}\cdot\text{ft}^3/\text{lbm}\cdot\text{R})(530 \text{ R})}{(50 \text{ ft/s})(15 \text{ psia})} = \mathbf{0.1333 \text{ ft}^2}$$

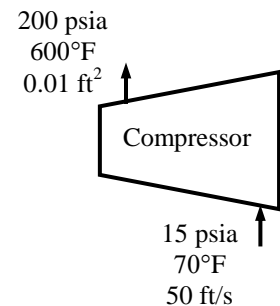

5-9 A rigid tank initially contains air at atmospheric conditions. The tank is connected to a supply line, and air is allowed to enter the tank until the density rises to a specified level. The mass of air that entered the tank is to be determined.

Properties The density of air is given to be 1.18 kg/m^3 at the beginning, and 5.30 kg/m^3 at the end.

Analysis We take the tank as the system, which is a control volume since mass crosses the boundary. The mass balance for this system can be expressed as

Mass balance:

$$m_{in} - m_{out} = \Delta m_{\text{system}} \rightarrow m_i = m_2 - m_1 = \rho_2 V - \rho_1 V$$

Substituting,

$$m_i = (\rho_2 - \rho_1)V = [(5.30 - 1.18) \text{ kg/m}^3](2 \text{ m}^3) = \mathbf{8.24 \text{ kg}}$$

Therefore, 8.24 kg of mass entered the tank.

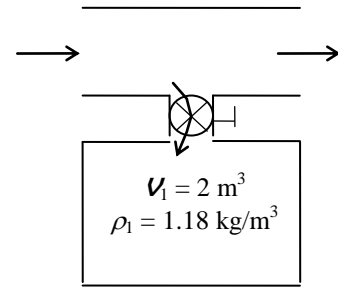

5-10 A cyclone separator is used to remove fine solid particles that are suspended in a gas stream. The mass flow rates at the two outlets and the amount of fly ash collected per year are to be determined.

Assumptions Flow through the separator is steady.

Analysis Since the ash particles cannot be converted into the gas and vice-versa, the mass flow rate of ash into the control volume must equal that going out, and the mass flow rate of flue gas into the control volume must equal that going out. Hence, the mass flow rate of ash leaving is

$$\dot{m}_{\text{ash}} = y_{\text{ash}} \dot{m}_{\text{in}} = (0.001)(10 \text{ kg/s}) = \mathbf{0.01 \text{ kg/s}}$$

The mass flow rate of flue gas leaving the separator is then

$$\dot{m}_{\text{flue gas}} = \dot{m}_{\text{in}} - \dot{m}_{\text{ash}} = 10 - 0.01 = \mathbf{9.99 \text{ kg/s}}$$

The amount of fly ash collected per year is

$$m_{\text{ash}} = \dot{m}_{\text{ash}} \Delta t = (0.01 \text{ kg/s})(365 \times 24 \times 3600 \text{ s/year}) = \mathbf{315,400 \text{ kg/year}}$$

5-11 A spherical hot-air balloon is considered. The time it takes to inflate the balloon is to be determined.

Assumptions 1 Air is an ideal gas.

Properties The gas constant of air is $R = 0.287 \text{ kPa}\cdot\text{m}^3/\text{kg}\cdot\text{K}$ (Table A-1).

Analysis The specific volume of air entering the balloon is

$$\nu = \frac{RT}{P} = \frac{(0.287 \text{ kPa}\cdot\text{m}^3/\text{kg}\cdot\text{K})(20 + 273 \text{ K})}{120 \text{ kPa}} = 0.7008 \text{ m}^3/\text{kg}$$

The mass flow rate at this entrance is

$$\dot{m} = \frac{A_c V}{\nu} = \frac{\pi D^2}{4} \frac{V}{\nu} = \frac{\pi(1.0 \text{ m})^2}{4} \frac{3 \text{ m/s}}{0.7008 \text{ m}^3/\text{kg}} = 3.362 \text{ kg/s}$$

The initial mass of the air in the balloon is

$$m_i = \frac{V_i}{\nu} = \frac{\pi D^3}{6\nu} = \frac{\pi(5 \text{ m})^3}{6(0.7008 \text{ m}^3/\text{kg})} = 93.39 \text{ kg}$$

Similarly, the final mass of air in the balloon is

$$m_f = \frac{V_f}{\nu} = \frac{\pi D^3}{6\nu} = \frac{\pi(15 \text{ m})^3}{6(0.7008 \text{ m}^3/\text{kg})} = 2522 \text{ kg}$$

The time it takes to inflate the balloon is determined from

$$\Delta t = \frac{m_f - m_i}{\dot{m}} = \frac{(2522 - 93.39) \text{ kg}}{3.362 \text{ kg/s}} = 722 \text{ s} = \mathbf{12.0 \text{ min}}$$

5-12 A desktop computer is to be cooled by a fan at a high elevation where the air density is low. The mass flow rate of air through the fan and the diameter of the casing for a given velocity are to be determined.

Assumptions Flow through the fan is steady.

Properties The density of air at a high elevation is given to be 0.7 kg/m^3 .

Analysis The mass flow rate of air is

$$\dot{m}_{\text{air}} = \rho \dot{V}_{\text{air}} = (0.7 \text{ kg/m}^3)(0.34 \text{ m}^3/\text{min}) = 0.238 \text{ kg/min} = \mathbf{0.0040 \text{ kg/s}}$$

If the mean velocity is 110 m/min , the diameter of the casing is

$$\dot{V} = AV = \frac{\pi D^2}{4} V \quad \rightarrow \quad D = \sqrt{\frac{4\dot{V}}{\pi V}} = \sqrt{\frac{4(0.34 \text{ m}^3/\text{min})}{\pi(110 \text{ m/min})}} = \mathbf{0.063 \text{ m}}$$

Therefore, the diameter of the casing must be at least 6.3 cm to ensure that the mean velocity does not exceed 110 m/min .

Discussion This problem shows that engineering systems are sized to satisfy certain constraints imposed by certain considerations.



5-13 A water pump increases water pressure. The diameters of the inlet and exit openings are given. The velocity of the water at the inlet and outlet are to be determined.

Assumptions 1 Flow through the pump is steady. 2 The specific volume remains constant.

Properties The inlet state of water is compressed liquid. We approximate it as a saturated liquid at the given temperature. Then, at 15°C and 40°C, we have (Table A-4)

$$\left. \begin{array}{l} T = 15^\circ\text{C} \\ x = 0 \end{array} \right\} \nu_1 = 0.001001 \text{ m}^3/\text{kg}$$

$$\left. \begin{array}{l} T = 40^\circ\text{C} \\ x = 0 \end{array} \right\} \nu_1 = 0.001008 \text{ m}^3/\text{kg}$$

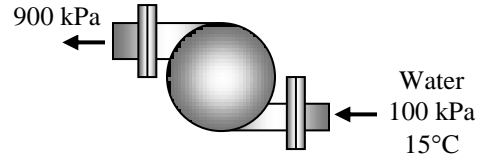

Analysis The velocity of the water at the inlet is

$$V_1 = \frac{\dot{m}\nu_1}{A_1} = \frac{4\dot{m}\nu_1}{\pi D_1^2} = \frac{4(0.5 \text{ kg/s})(0.001001 \text{ m}^3/\text{kg})}{\pi(0.01 \text{ m})^2} = \mathbf{6.37 \text{ m/s}}$$

Since the mass flow rate and the specific volume remains constant, the velocity at the pump exit is

$$V_2 = V_1 \frac{A_1}{A_2} = V_1 \left(\frac{D_1}{D_2} \right)^2 = (6.37 \text{ m/s}) \left(\frac{0.01 \text{ m}}{0.015 \text{ m}} \right)^2 = \mathbf{2.83 \text{ m/s}}$$

Using the specific volume at 40°C, the water velocity at the inlet becomes

$$V_1 = \frac{\dot{m}\nu_1}{A_1} = \frac{4\dot{m}\nu_1}{\pi D_1^2} = \frac{4(0.5 \text{ kg/s})(0.001008 \text{ m}^3/\text{kg})}{\pi(0.01 \text{ m})^2} = \mathbf{6.42 \text{ m/s}}$$

which is a 0.8% increase in velocity.

5-14 Refrigerant-134a flows through a pipe. Heat is supplied to R-134a. The volume flow rates of air at the inlet and exit, the mass flow rate, and the velocity at the exit are to be determined.

Properties The specific volumes of R-134a at the inlet and exit are (Table A-13)

$$\left. \begin{array}{l} P_1 = 200 \text{ kPa} \\ T_1 = 20^\circ\text{C} \end{array} \right\} \nu_1 = 0.1142 \text{ m}^3/\text{kg} \quad \left. \begin{array}{l} P_2 = 180 \text{ kPa} \\ T_2 = 40^\circ\text{C} \end{array} \right\} \nu_2 = 0.1374 \text{ m}^3/\text{kg}$$

Analysis

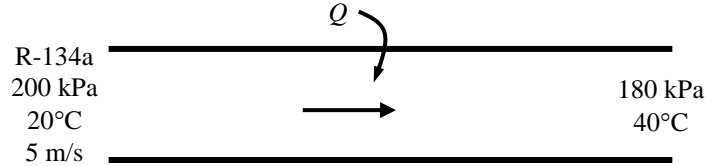

(a) (b) The volume flow rate at the inlet and the mass flow rate are

$$\dot{V}_1 = A_c V_1 = \frac{\pi D^2}{4} V_1 = \frac{\pi (0.28 \text{ m})^2}{4} (5 \text{ m/s}) = \mathbf{0.3079 \text{ m}^3/\text{s}}$$

$$\dot{m} = \frac{1}{\nu_1} A_c V_1 = \frac{1}{\nu_1} \frac{\pi D^2}{4} V_1 = \frac{1}{0.1142 \text{ m}^3/\text{kg}} \frac{\pi (0.28 \text{ m})^2}{4} (5 \text{ m/s}) = \mathbf{2.696 \text{ kg/s}}$$

(c) Noting that mass flow rate is constant, the volume flow rate and the velocity at the exit of the pipe are determined from

$$\dot{V}_2 = \dot{m} \nu_2 = (2.696 \text{ kg/s})(0.1374 \text{ m}^3/\text{kg}) = \mathbf{0.3705 \text{ m}^3/\text{s}}$$

$$V_2 = \frac{\dot{V}_2}{A_c} = \frac{0.3705 \text{ m}^3/\text{s}}{\frac{\pi (0.28 \text{ m})^2}{4}} = \mathbf{6.02 \text{ m/s}}$$

5-15 A smoking lounge that can accommodate 15 smokers is considered. The required minimum flow rate of air that needs to be supplied to the lounge and the diameter of the duct are to be determined.

Assumptions Infiltration of air into the smoking lounge is negligible.

Properties The minimum fresh air requirements for a smoking lounge is given to be 30 L/s per person.

Analysis The required minimum flow rate of air that needs to be supplied to the lounge is determined directly from

$$\dot{V}_{\text{air}} = \dot{V}_{\text{air per person}} (\text{No. of persons})$$

$$= (30 \text{ L/s} \cdot \text{person})(15 \text{ persons}) = 450 \text{ L/s} = \mathbf{0.45 \text{ m}^3/\text{s}}$$

The volume flow rate of fresh air can be expressed as

$$\dot{V} = VA = V(\pi D^2 / 4)$$

Solving for the diameter D and substituting,

$$D = \sqrt{\frac{4\dot{V}}{\pi V}} = \sqrt{\frac{4(0.45 \text{ m}^3/\text{s})}{\pi(8 \text{ m/s})}} = \mathbf{0.268 \text{ m}}$$

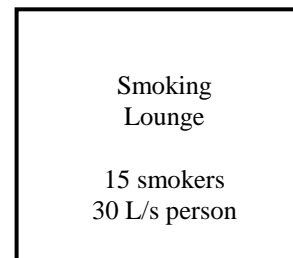

Therefore, the diameter of the fresh air duct should be at least 26.8 cm if the velocity of air is not to exceed 8 m/s.

5-16 Warm water is withdrawn from a solar water storage tank while cold water enters the tank. The amount of water in the tank in a 20-minute period is to be determined.

Properties The density of water is taken to be 1000 kg/m^3 for both cold and warm water.

Analysis The initial mass in the tank is first determined from

$$m_1 = \rho V_{\text{tank}} = (1000 \text{ kg/m}^3)(0.3 \text{ m}^3) = 300 \text{ kg}$$

The amount of warm water leaving the tank during a 20-min period is

$$m_e = \rho A_c V \Delta t = (1000 \text{ kg/m}^3) \frac{\pi(0.02 \text{ m})^2}{4} (0.5 \text{ m/s})(20 \times 60 \text{ s}) = 188.5 \text{ kg}$$

The amount of cold water entering the tank during a 20-min period is

$$m_i = \rho \dot{V}_c \Delta t = (1000 \text{ kg/m}^3)(0.005 \text{ m}^3/\text{min})(20 \text{ min}) = 100 \text{ kg}$$

The final mass in the tank can be determined from a mass balance as

$$m_i - m_e = m_2 - m_1 \longrightarrow m_2 = m_1 + m_i - m_e = 300 + 100 - 188.5 = \mathbf{211.5 \text{ kg}}$$

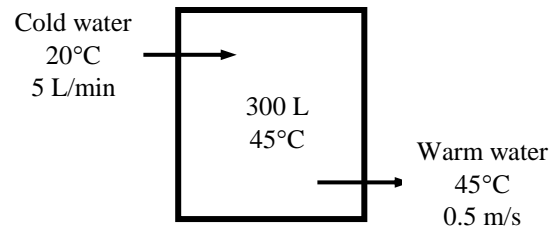

Flow Work and Energy Transfer by Mass

5-17C Flow energy or flow work is the energy needed to push a fluid into or out of a control volume. Fluids at rest do not possess any flow energy.

5-18C Flowing fluids possess flow energy in addition to the forms of energy a fluid at rest possesses. The total energy of a fluid at rest consists of internal, kinetic, and potential energies. The total energy of a flowing fluid consists of internal, kinetic, potential, and flow energies.

5-19 Warm air in a house is forced to leave by the infiltrating cold outside air at a specified rate. The net energy loss due to mass transfer is to be determined.

Assumptions 1 The flow of the air into and out of the house through the cracks is steady. **2** The kinetic and potential energies are negligible. **3** Air is an ideal gas with constant specific heats at room temperature.

Properties The gas constant of air is $R = 0.287 \text{ kPa}\cdot\text{m}^3/\text{kg}\cdot\text{K}$ (Table A-1). The constant pressure specific heat of air at room temperature is $c_p = 1.005 \text{ kJ}/\text{kg}\cdot^\circ\text{C}$ (Table A-2).

Analysis The density of air at the indoor conditions and its mass flow rate are

$$\rho = \frac{P}{RT} = \frac{101.325 \text{ kPa}}{(0.287 \text{ kPa}\cdot\text{m}^3/\text{kg}\cdot\text{K})(24 + 273)\text{K}} = 1.189 \text{ kg}/\text{m}^3$$

$$\dot{m} = \rho\dot{V} = (1.189 \text{ kg}/\text{m}^3)(150 \text{ m}^3/\text{h}) = 178.35 \text{ kg}/\text{h} = 0.0495 \text{ kg}/\text{s}$$

Noting that the total energy of a flowing fluid is equal to its enthalpy when the kinetic and potential energies are negligible, and that the rate of energy transfer by mass is equal to the product of the mass flow rate and the total energy of the fluid per unit mass, the rates of energy transfer by mass into and out of the house by air are

$$\dot{E}_{\text{mass, in}} = \dot{m}\theta_{\text{in}} = \dot{m}h_1$$

$$\dot{E}_{\text{mass, out}} = \dot{m}\theta_{\text{out}} = \dot{m}h_2$$

The net energy loss by air infiltration is equal to the difference between the outgoing and incoming energy flow rates, which is

$$\begin{aligned} \Delta\dot{E}_{\text{mass}} &= \dot{E}_{\text{mass, out}} - \dot{E}_{\text{mass, in}} = \dot{m}(h_2 - h_1) = \dot{m}c_p(T_2 - T_1) \\ &= (0.0495 \text{ kg}/\text{s})(1.005 \text{ kJ}/\text{kg}\cdot^\circ\text{C})(24 - 5)^\circ\text{C} = 0.945 \text{ kJ}/\text{s} \\ &= \mathbf{0.945 \text{ kW}} \end{aligned}$$

This quantity represents the rate of energy transfer to the refrigerant in the compressor.

Discussion The rate of energy loss by infiltration will be less in reality since some air will leave the house before it is fully heated to 24°C .

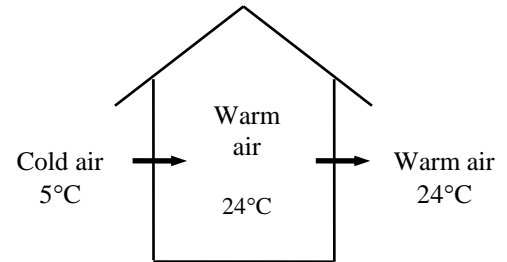

5-20E A water pump increases water pressure. The flow work required by the pump is to be determined.

Assumptions 1 Flow through the pump is steady. **2** The state of water at the pump inlet is saturated liquid. **3** The specific volume remains constant.

Properties The specific volume of saturated liquid water at 15 psia is

$$\nu = \nu_{f@15 \text{ psia}} = 0.01672 \text{ ft}^3/\text{lbm} \quad (\text{Table A-5E})$$

Then the flow work relation gives

$$\begin{aligned} w_{\text{flow}} &= P_2\nu_2 - P_1\nu_1 = \nu(P_2 - P_1) \\ &= (0.01672 \text{ ft}^3/\text{lbm})(80 - 15)\text{psia} \left(\frac{1 \text{ Btu}}{5.404 \text{ psia}\cdot\text{ft}^3} \right) \\ &= \mathbf{0.201 \text{ Btu}/\text{lbm}} \end{aligned}$$

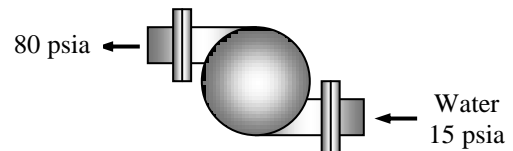

5-21 Refrigerant-134a enters a compressor as a saturated vapor at a specified pressure, and leaves as superheated vapor at a specified rate. The rates of energy transfer by mass into and out of the compressor are to be determined.

Assumptions **1** The flow of the refrigerant through the compressor is steady. **2** The kinetic and potential energies are negligible, and thus they are not considered.

Properties The enthalpy of refrigerant-134a at the inlet and the exit are (Tables A-12 and A-13)

$$h_1 = h_{g@0.14 \text{ MPa}} = 239.19 \text{ kJ/kg} \quad \left. \begin{array}{l} P_2 = 0.8 \text{ MPa} \\ T_2 = 60^\circ\text{C} \end{array} \right\} h_2 = 296.82 \text{ kJ/kg}$$

Analysis Noting that the total energy of a flowing fluid is equal to its enthalpy when the kinetic and potential energies are negligible, and that the rate of energy transfer by mass is equal to the product of the mass flow rate and the total energy of the fluid per unit mass, the rates of energy transfer by mass into and out of the compressor are

$$\dot{E}_{\text{mass, in}} = \dot{m}\theta_{\text{in}} = \dot{m}h_1 = (0.06 \text{ kg/s})(239.19 \text{ kJ/kg}) = 14.35 \text{ kJ/s} = \mathbf{14.35 \text{ kW}}$$

$$\dot{E}_{\text{mass, out}} = \dot{m}\theta_{\text{out}} = \dot{m}h_2 = (0.06 \text{ kg/s})(296.82 \text{ kJ/kg}) = 17.81 \text{ kJ/s} = \mathbf{17.81 \text{ kW}}$$

Discussion The numerical values of the energy entering or leaving a device by mass alone does not mean much since this value depends on the reference point selected for enthalpy (it could even be negative). The significant quantity here is the difference between the outgoing and incoming energy flow rates, which is

$$\Delta \dot{E}_{\text{mass}} = \dot{E}_{\text{mass, out}} - \dot{E}_{\text{mass, in}} = 17.81 - 14.35 = 3.46 \text{ kW}$$

This quantity represents the rate of energy transfer to the refrigerant in the compressor.

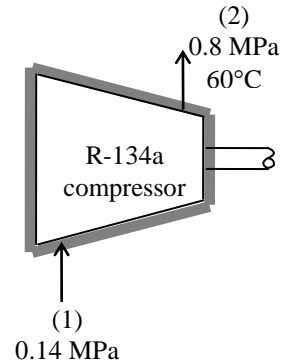

5-22E Steam is leaving a pressure cooker at a specified pressure. The velocity, flow rate, the total and flow energies, and the rate of energy transfer by mass are to be determined.

Assumptions 1 The flow is steady, and the initial start-up period is disregarded. **2** The kinetic and potential energies are negligible, and thus they are not considered. **3** Saturation conditions exist within the cooker at all times so that steam leaves the cooker as a saturated vapor at 20 psia.

Properties The properties of saturated liquid water and water vapor at 20 psia are $\nu_f = 0.01683 \text{ ft}^3/\text{lbm}$, $\nu_g = 20.093 \text{ ft}^3/\text{lbm}$, $u_g = 1081.8 \text{ Btu/lbm}$, and $h_g = 1156.2 \text{ Btu/lbm}$ (Table A-5E).

Analysis (a) Saturation conditions exist in a pressure cooker at all times after the steady operating conditions are established. Therefore, the liquid has the properties of saturated liquid and the exiting steam has the properties of saturated vapor at the operating pressure. The amount of liquid that has evaporated, the mass flow rate of the exiting steam, and the exit velocity are

$$m = \frac{\Delta \nu_{\text{liquid}}}{\nu_f} = \frac{0.6 \text{ gal}}{0.01683 \text{ ft}^3/\text{lbm}} \left(\frac{0.13368 \text{ ft}^3}{1 \text{ gal}} \right) = 4.766 \text{ lbm}$$

$$\dot{m} = \frac{m}{\Delta t} = \frac{4.766 \text{ lbm}}{45 \text{ min}} = 0.1059 \text{ lbm/min} = \mathbf{1.765 \times 10^{-3} \text{ lbm/s}}$$

$$V = \frac{\dot{m}}{\rho_g A_c} = \frac{\dot{m} \nu_g}{A_c} = \frac{(1.765 \times 10^{-3} \text{ lbm/s})(20.093 \text{ ft}^3/\text{lbm})}{0.15 \text{ in}^2} \left(\frac{144 \text{ in}^2}{1 \text{ ft}^2} \right) = \mathbf{34.1 \text{ ft/s}}$$

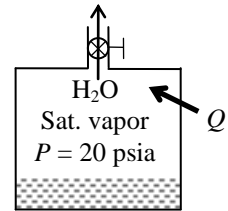

(b) Noting that $h = u + P\nu$ and that the kinetic and potential energies are disregarded, the flow and total energies of the exiting steam are

$$e_{\text{flow}} = P\nu = h - u = 1156.2 - 1081.8 = \mathbf{74.4 \text{ Btu/lbm}}$$

$$\theta = h + ke + pe \cong h = \mathbf{1156.2 \text{ Btu/lbm}}$$

Note that the kinetic energy in this case is $ke = V^2/2 = (34.1 \text{ ft/s})^2/2 = 581 \text{ ft}^2/\text{s}^2 = 0.0232 \text{ Btu/lbm}$, which is very small compared to enthalpy.

(c) The rate at which energy is leaving the cooker by mass is simply the product of the mass flow rate and the total energy of the exiting steam per unit mass,

$$\dot{E}_{\text{mass}} = \dot{m}\theta = (1.765 \times 10^{-3} \text{ lbm/s})(1156.2 \text{ Btu/lbm}) = \mathbf{2.04 \text{ Btu/s}}$$

Discussion The numerical value of the energy leaving the cooker with steam alone does not mean much since this value depends on the reference point selected for enthalpy (it could even be negative). The significant quantity is the difference between the enthalpies of the exiting vapor and the liquid inside (which is h_{fg}) since it relates directly to the amount of energy supplied to the cooker.

Steady Flow Energy Balance: Nozzles and Diffusers

5-23C It is mostly converted to internal energy as shown by a rise in the fluid temperature.

5-24C The kinetic energy of a fluid increases at the expense of the internal energy as evidenced by a decrease in the fluid temperature.

5-25C Heat transfer to the fluid as it flows through a nozzle is desirable since it will probably increase the kinetic energy of the fluid. Heat transfer from the fluid will decrease the exit velocity.

5-26E Air is accelerated in a nozzle from 150 ft/s to 900 ft/s. The exit temperature of air and the exit area of the nozzle are to be determined.

Assumptions 1 This is a steady-flow process since there is no change with time. **2** Air is an ideal gas with variable specific heats. **3** Potential energy changes are negligible. **4** There are no work interactions.

Properties The enthalpy of air at the inlet is $h_1 = 143.47$ Btu/lbm (Table A-17E).

Analysis (a) There is only one inlet and one exit, and thus $\dot{m}_1 = \dot{m}_2 = \dot{m}$. We take nozzle as the system, which is a control volume since mass crosses the boundary. The energy balance for this steady-flow system can be expressed in the rate form as

$$\underbrace{\dot{E}_{\text{in}} - \dot{E}_{\text{out}}}_{\text{Rate of net energy transfer by heat, work, and mass}} = \underbrace{\Delta \dot{E}_{\text{system}}^{\text{no (steady)}}}_{\text{Rate of change in internal, kinetic, potential, etc. energies}} = 0$$

$$\dot{E}_{\text{in}} = \dot{E}_{\text{out}}$$

$$\dot{m}(h_1 + V_1^2/2) = \dot{Q}_{\text{out}} + \dot{m}(h_2 + V_2^2/2) \quad (\text{since } \dot{W} \cong \Delta p_e \cong 0)$$

$$-\dot{Q}_{\text{out}} = \dot{m} \left(h_2 - h_1 + \frac{V_2^2 - V_1^2}{2} \right)$$

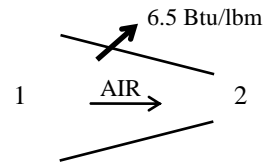

or,

$$\begin{aligned} h_2 &= -q_{\text{out}} + h_1 - \frac{V_2^2 - V_1^2}{2} \\ &= -6.5 \text{ Btu/lbm} + 143.47 \text{ Btu/lbm} - \frac{(900 \text{ ft/s})^2 - (150 \text{ ft/s})^2}{2} \left(\frac{1 \text{ Btu/lbm}}{25,037 \text{ ft}^2/\text{s}^2} \right) \\ &= 121.2 \text{ Btu/lbm} \end{aligned}$$

Thus, from Table A-17E, $T_2 = \mathbf{507 \text{ R}}$

(b) The exit area is determined from the conservation of mass relation,

$$\begin{aligned} \frac{1}{v_2} A_2 V_2 &= \frac{1}{v_1} A_1 V_1 \longrightarrow A_2 = \frac{v_2}{v_1} \frac{V_1}{V_2} A_1 = \left(\frac{RT_2/P_2}{RT_1/P_1} \right) \frac{V_1}{V_2} A_1 \\ A_2 &= \frac{(508/14.7)(150 \text{ ft/s})}{(600/50)(900 \text{ ft/s})} (0.1 \text{ ft}^2) = \mathbf{0.048 \text{ ft}^2} \end{aligned}$$

5-27E Air is accelerated in an adiabatic nozzle. The velocity at the exit is to be determined.

Assumptions 1 This is a steady-flow process since there is no change with time. **2** Air is an ideal gas with constant specific heats. **3** Potential energy changes are negligible. **4** There are no work interactions. **5** The nozzle is adiabatic.

Properties The specific heat of air at the average temperature of $(700+645)/2=672.5^\circ\text{F}$ is $c_p = 0.253 \text{ Btu/lbm}\cdot\text{R}$ (Table A-2Eb).

Analysis There is only one inlet and one exit, and thus $\dot{m}_1 = \dot{m}_2 = \dot{m}$. We take nozzle as the system, which is a control volume since mass crosses the boundary. The energy balance for this steady-flow system can be expressed in the rate form as

$$\underbrace{\dot{E}_{\text{in}} - \dot{E}_{\text{out}}}_{\substack{\text{Rate of net energy transfer} \\ \text{by heat, work, and mass}}} = \underbrace{\Delta\dot{E}_{\text{system}}}_{\substack{\text{Rate of change in internal, kinetic,} \\ \text{potential, etc. energies}}} \stackrel{\text{no (steady)}}{=} 0$$

$$\dot{E}_{\text{in}} = \dot{E}_{\text{out}}$$

$$\dot{m}(h_1 + V_1^2/2) = \dot{m}(h_2 + V_2^2/2)$$

$$h_1 + V_1^2/2 = h_2 + V_2^2/2$$

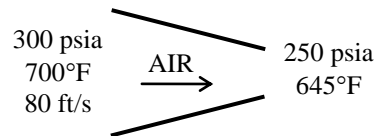

Solving for exit velocity,

$$\begin{aligned} V_2 &= \left[V_1^2 + 2(h_1 - h_2) \right]^{0.5} = \left[V_1^2 + 2c_p(T_1 - T_2) \right]^{0.5} \\ &= \left[(80 \text{ ft/s})^2 + 2(0.253 \text{ Btu/lbm}\cdot\text{R})(700 - 645)\text{R} \left(\frac{25,037 \text{ ft}^2/\text{s}^2}{1 \text{ Btu/lbm}} \right) \right]^{0.5} \\ &= \mathbf{838.6 \text{ ft/s}} \end{aligned}$$

5-28 Air is decelerated in an adiabatic diffuser. The velocity at the exit is to be determined.

Assumptions 1 This is a steady-flow process since there is no change with time. **2** Air is an ideal gas with constant specific heats. **3** Potential energy changes are negligible. **4** There are no work interactions. **5** The diffuser is adiabatic.

Properties The specific heat of air at the average temperature of $(30+90)/2 = 60^\circ\text{C} = 333\text{ K}$ is $c_p = 1.007\text{ kJ/kg}\cdot\text{K}$ (Table A-2b).

Analysis There is only one inlet and one exit, and thus $\dot{m}_1 = \dot{m}_2 = \dot{m}$. We take diffuser as the system, which is a control volume since mass crosses the boundary. The energy balance for this steady-flow system can be expressed in the rate form as

$$\underbrace{\dot{E}_{\text{in}} - \dot{E}_{\text{out}}}_{\substack{\text{Rate of net energy transfer} \\ \text{by heat, work, and mass}}} = \underbrace{\Delta\dot{E}_{\text{system}}}_{\substack{\text{Rate of change in internal, kinetic,} \\ \text{potential, etc. energies}}} \stackrel{\text{no (steady)}}{=} 0$$

$$\dot{E}_{\text{in}} = \dot{E}_{\text{out}}$$

$$\dot{m}(h_1 + V_1^2/2) = \dot{m}(h_2 + V_2^2/2)$$

$$h_1 + V_1^2/2 = h_2 + V_2^2/2$$

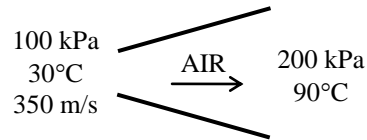

Solving for exit velocity,

$$\begin{aligned} V_2 &= \left[V_1^2 + 2(h_1 - h_2) \right]^{0.5} = \left[V_1^2 + 2c_p(T_1 - T_2) \right]^{0.5} \\ &= \left[(350\text{ m/s})^2 + 2(1.007\text{ kJ/kg}\cdot\text{K})(30 - 90)\text{K} \left(\frac{1000\text{ m}^2/\text{s}^2}{1\text{ kJ/kg}} \right) \right]^{0.5} \\ &= \mathbf{40.7\text{ m/s}} \end{aligned}$$

5-29 Air is accelerated in a nozzle from 120 m/s to 380 m/s. The exit temperature and pressure of air are to be determined.

Assumptions 1 This is a steady-flow process since there is no change with time. **2** Air is an ideal gas with variable specific heats. **3** Potential energy changes are negligible. **4** The device is adiabatic and thus heat transfer is negligible. **5** There are no work interactions.

Properties The enthalpy of air at the inlet temperature of 500 K is $h_1 = 503.02$ kJ/kg (Table A-17).

Analysis (a) There is only one inlet and one exit, and thus $\dot{m}_1 = \dot{m}_2 = \dot{m}$. We take nozzle as the system, which is a control volume since mass crosses the boundary. The energy balance for this steady-flow system can be expressed in the rate form as

$$\underbrace{\dot{E}_{\text{in}} - \dot{E}_{\text{out}}}_{\text{Rate of net energy transfer by heat, work, and mass}} = \underbrace{\Delta \dot{E}_{\text{system}}}_{\text{Rate of change in internal, kinetic, potential, etc. energies}} \stackrel{\text{no (steady)}}{=} 0$$

$$\dot{E}_{\text{in}} = \dot{E}_{\text{out}}$$

$$\dot{m}(h_1 + V_1^2/2) = \dot{m}(h_2 + V_2^2/2) \quad (\text{since } \dot{Q} \cong \dot{W} \cong \Delta \text{pe} \cong 0)$$

$$0 = h_2 - h_1 + \frac{V_2^2 - V_1^2}{2}$$

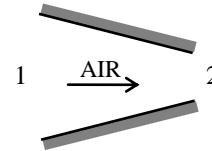

or,

$$h_2 = h_1 - \frac{V_2^2 - V_1^2}{2} = 503.02 \text{ kJ/kg} - \frac{(380 \text{ m/s})^2 - (120 \text{ m/s})^2}{2} \left(\frac{1 \text{ kJ/kg}}{1000 \text{ m}^2/\text{s}^2} \right) = 438.02 \text{ kJ/kg}$$

Then from Table A-17 we read $T_2 = 436.5 \text{ K} \cong \mathbf{437 \text{ K}}$

(b) The exit pressure is determined from the conservation of mass relation,

$$\frac{1}{\nu_2} A_2 V_2 = \frac{1}{\nu_1} A_1 V_1 \longrightarrow \frac{1}{RT_2 / P_2} A_2 V_2 = \frac{1}{RT_1 / P_1} A_1 V_1$$

Thus,

$$P_2 = \frac{A_1 T_2 V_1}{A_2 T_1 V_2} P_1 = \frac{2}{1} \frac{(436.5 \text{ K})(120 \text{ m/s})}{(500 \text{ K})(380 \text{ m/s})} (600 \text{ kPa}) = \mathbf{331 \text{ kPa}}$$

5-30 Heat is lost from the steam flowing in a nozzle. The velocity and the volume flow rate at the nozzle exit are to be determined.

Assumptions 1 This is a steady-flow process since there is no change with time. **2** Potential energy change is negligible. **3** There are no work interactions.

Analysis We take the steam as the system, which is a control volume since mass crosses the boundary. The energy balance for this steady-flow system can be expressed in the rate form as

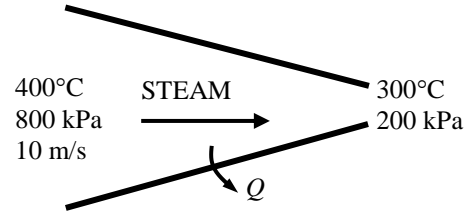

Energy balance:

$$\underbrace{\dot{E}_{\text{in}} - \dot{E}_{\text{out}}}_{\text{Rate of net energy transfer by heat, work, and mass}} = \underbrace{\Delta \dot{E}_{\text{system}}}_{\text{Rate of change in internal, kinetic, potential, etc. energies}} \stackrel{\text{no (steady)}}{=} 0$$

$$\dot{E}_{\text{in}} = \dot{E}_{\text{out}}$$

$$\dot{m} \left(h_1 + \frac{V_1^2}{2} \right) = \dot{m} \left(h_2 + \frac{V_2^2}{2} \right) + \dot{Q}_{\text{out}} \quad \text{since } \dot{W} \cong \Delta p e \cong 0$$

or

$$h_1 + \frac{V_1^2}{2} = h_2 + \frac{V_2^2}{2} + \frac{\dot{Q}_{\text{out}}}{\dot{m}}$$

The properties of steam at the inlet and exit are (Table A-6)

$$\left. \begin{array}{l} P_1 = 800 \text{ kPa} \\ T_1 = 400^\circ\text{C} \end{array} \right\} \begin{array}{l} v_1 = 0.38429 \text{ m}^3/\text{kg} \\ h_1 = 3267.7 \text{ kJ/kg} \end{array}$$

$$\left. \begin{array}{l} P_2 = 200 \text{ kPa} \\ T_2 = 300^\circ\text{C} \end{array} \right\} \begin{array}{l} v_2 = 1.31623 \text{ m}^3/\text{kg} \\ h_2 = 3072.1 \text{ kJ/kg} \end{array}$$

The mass flow rate of the steam is

$$\dot{m} = \frac{1}{v_1} A_1 V_1 = \frac{1}{0.38429 \text{ m}^3/\text{s}} (0.08 \text{ m}^2)(10 \text{ m/s}) = 2.082 \text{ kg/s}$$

Substituting,

$$3267.7 \text{ kJ/kg} + \frac{(10 \text{ m/s})^2}{2} \left(\frac{1 \text{ kJ/kg}}{1000 \text{ m}^2/\text{s}^2} \right) = 3072.1 \text{ kJ/kg} + \frac{V_2^2}{2} \left(\frac{1 \text{ kJ/kg}}{1000 \text{ m}^2/\text{s}^2} \right) + \frac{25 \text{ kJ/s}}{2.082 \text{ kg/s}}$$

$$\longrightarrow V_2 = \mathbf{606 \text{ m/s}}$$

The volume flow rate at the exit of the nozzle is

$$\dot{V}_2 = \dot{m} v_2 = (2.082 \text{ kg/s})(1.31623 \text{ m}^3/\text{kg}) = \mathbf{2.74 \text{ m}^3/\text{s}}$$

5-31  Steam is accelerated in a nozzle from a velocity of 40 m/s to 300 m/s. The exit temperature and the ratio of the inlet-to-exit area of the nozzle are to be determined.

Assumptions **1** This is a steady-flow process since there is no change with time. **2** Potential energy changes are negligible. **3** There are no work interactions. **4** The device is adiabatic and thus heat transfer is negligible.

Properties From the steam tables (Table A-6),

$$\left. \begin{array}{l} P_1 = 3 \text{ MPa} \\ T_1 = 400^\circ\text{C} \end{array} \right\} \begin{array}{l} \nu_1 = 0.09938 \text{ m}^3/\text{kg} \\ h_1 = 3231.7 \text{ kJ/kg} \end{array}$$

Analysis (a) There is only one inlet and one exit, and thus $\dot{m}_1 = \dot{m}_2 = \dot{m}$. We take nozzle as the system, which is a control volume since mass crosses the boundary. The energy balance for this steady-flow system can be expressed in the rate form as

$$\underbrace{\dot{E}_{\text{in}} - \dot{E}_{\text{out}}}_{\text{Rate of net energy transfer by heat, work, and mass}} = \underbrace{\Delta \dot{E}_{\text{system}}}_{\text{Rate of change in internal, kinetic, potential, etc. energies}} \stackrel{\text{no (steady)}}{=} 0$$

$$\dot{E}_{\text{in}} = \dot{E}_{\text{out}}$$

$$\dot{m}(h_1 + V_1^2/2) = \dot{m}(h_2 + V_2^2/2) \quad (\text{since } \dot{Q} \cong \dot{W} \cong \Delta p_e \cong 0)$$

$$0 = h_2 - h_1 + \frac{V_2^2 - V_1^2}{2}$$

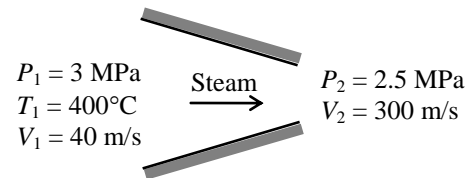

or,

$$h_2 = h_1 - \frac{V_2^2 - V_1^2}{2} = 3231.7 \text{ kJ/kg} - \frac{(300 \text{ m/s})^2 - (40 \text{ m/s})^2}{2} \left(\frac{1 \text{ kJ/kg}}{1000 \text{ m}^2/\text{s}^2} \right) = 3187.5 \text{ kJ/kg}$$

Thus,

$$\left. \begin{array}{l} P_2 = 2.5 \text{ MPa} \\ h_2 = 3187.5 \text{ kJ/kg} \end{array} \right\} \begin{array}{l} T_2 = \mathbf{376.6^\circ\text{C}} \\ \nu_2 = 0.11533 \text{ m}^3/\text{kg} \end{array}$$

(b) The ratio of the inlet to exit area is determined from the conservation of mass relation,

$$\frac{1}{\nu_2} A_2 V_2 = \frac{1}{\nu_1} A_1 V_1 \longrightarrow \frac{A_1}{A_2} = \frac{\nu_1}{\nu_2} \frac{V_2}{V_1} = \frac{(0.09938 \text{ m}^3/\text{kg})(300 \text{ m/s})}{(0.11533 \text{ m}^3/\text{kg})(40 \text{ m/s})} = \mathbf{6.46}$$

5-32E Air is decelerated in a diffuser from 750 ft/s to a low velocity. The exit temperature and the exit velocity of air are to be determined.

Assumptions 1 This is a steady-flow process since there is no change with time. **2** Air is an ideal gas with variable specific heats. **3** Potential energy changes are negligible. **4** The device is adiabatic and thus heat transfer is negligible. **5** There are no work interactions.

Properties The enthalpy of air at the inlet temperature of 65°F (or 520 R) is $h_1 = 125.40$ Btu/lbm (Table A-17E).

Analysis (a) There is only one inlet and one exit, and thus $\dot{m}_1 = \dot{m}_2 = \dot{m}$. We take diffuser as the system, which is a control volume since mass crosses the boundary. The energy balance for this steady-flow system can be expressed in the rate form as

$$\underbrace{\dot{E}_{\text{in}} - \dot{E}_{\text{out}}}_{\text{Rate of net energy transfer by heat, work, and mass}} = \underbrace{\Delta \dot{E}_{\text{system}}}_{\text{Rate of change in internal, kinetic, potential, etc. energies}} \stackrel{\text{no (steady)}}{=} 0$$

$$\dot{E}_{\text{in}} = \dot{E}_{\text{out}}$$

$$\dot{m}(h_1 + V_1^2/2) = \dot{m}(h_2 + V_2^2/2) \quad (\text{since } \dot{Q} \cong \dot{W} \cong \Delta pe \cong 0)$$

$$0 = h_2 - h_1 + \frac{V_2^2 - V_1^2}{2} \quad ,$$

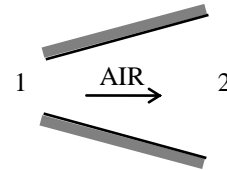

or,

$$h_2 = h_1 - \frac{V_2^2 - V_1^2}{2} = 125.40 \text{ Btu/lbm} - \frac{0 - (750 \text{ ft/s})^2}{2} \left(\frac{1 \text{ Btu/lbm}}{25,037 \text{ ft}^2/\text{s}^2} \right) = 136.63 \text{ Btu/lbm}$$

From Table A-17E,

$$T_2 = 571.6 \text{ R} = \mathbf{112^\circ\text{F}}$$

(b) The exit velocity of air is determined from the conservation of mass relation,

$$\frac{1}{\nu_2} A_2 V_2 = \frac{1}{\nu_1} A_1 V_1 \longrightarrow \frac{1}{RT_2/P_2} A_2 V_2 = \frac{1}{RT_1/P_1} A_1 V_1$$

Thus,

$$V_2 = \frac{A_1 T_2 P_1}{A_2 T_1 P_2} V_1 = \frac{1}{3} \frac{(571.6 \text{ R})(13 \text{ psia})}{(525 \text{ R})(14.5 \text{ psia})} (750 \text{ ft/s}) = \mathbf{244 \text{ ft/s}}$$

5-33 CO₂ gas is accelerated in a nozzle to 450 m/s. The inlet velocity and the exit temperature are to be determined.

Assumptions **1** This is a steady-flow process since there is no change with time. **2** CO₂ is an ideal gas with variable specific heats. **3** Potential energy changes are negligible. **4** The device is adiabatic and thus heat transfer is negligible. **5** There are no work interactions.

Properties The gas constant and molar mass of CO₂ are 0.1889 kPa·m³/kg·K and 44 kg/kmol (Table A-1). The enthalpy of CO₂ at 500°C is $\bar{h}_1 = 30,797$ kJ/kmol (Table A-20).

Analysis (a) There is only one inlet and one exit, and thus $\dot{m}_1 = \dot{m}_2 = \dot{m}$. Using the ideal gas relation, the specific volume is determined to be

$$v_1 = \frac{RT_1}{P_1} = \frac{(0.1889 \text{ kPa} \cdot \text{m}^3/\text{kg} \cdot \text{K})(773 \text{ K})}{1000 \text{ kPa}} = 0.146 \text{ m}^3/\text{kg}$$

Thus,

$$\dot{m} = \frac{1}{v_1} A_1 V_1 \longrightarrow V_1 = \frac{\dot{m} v_1}{A_1} = \frac{(6000/3600 \text{ kg/s})(0.146 \text{ m}^3/\text{kg})}{40 \times 10^{-4} \text{ m}^2} = \mathbf{60.8 \text{ m/s}}$$

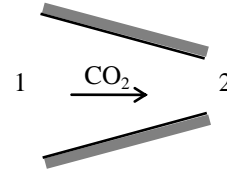

(b) We take nozzle as the system, which is a control volume since mass crosses the boundary. The energy balance for this steady-flow system can be expressed in the rate form as

$$\underbrace{\dot{E}_{\text{in}} - \dot{E}_{\text{out}}}_{\text{Rate of net energy transfer by heat, work, and mass}} = \underbrace{\Delta \dot{E}_{\text{system}}}_{\text{Rate of change in internal, kinetic, potential, etc. energies}} \stackrel{\text{no (steady)}}{=} 0$$

$$\dot{E}_{\text{in}} = \dot{E}_{\text{out}}$$

$$\dot{m}(h_1 + V_1^2/2) = \dot{m}(h_2 + V_2^2/2) \quad (\text{since } \dot{Q} \cong \dot{W} \cong \Delta \text{pe} \cong 0)$$

$$0 = h_2 - h_1 + \frac{V_2^2 - V_1^2}{2}$$

Substituting,

$$\begin{aligned} \bar{h}_2 &= \bar{h}_1 - \frac{V_2^2 - V_1^2}{2} M \\ &= 30,797 \text{ kJ/kmol} - \frac{(450 \text{ m/s})^2 - (60.8 \text{ m/s})^2}{2} \left(\frac{1 \text{ kJ/kg}}{1000 \text{ m}^2/\text{s}^2} \right) (44 \text{ kg/kmol}) \\ &= 26,423 \text{ kJ/kmol} \end{aligned}$$

Then the exit temperature of CO₂ from Table A-20 is obtained to be $T_2 = 685.8 \text{ K} \cong \mathbf{686 \text{ K}}$

5-34 R-134a is accelerated in a nozzle from a velocity of 20 m/s. The exit velocity of the refrigerant and the ratio of the inlet-to-exit area of the nozzle are to be determined.

Assumptions **1** This is a steady-flow process since there is no change with time. **2** Potential energy changes are negligible. **3** There are no work interactions. **4** The device is adiabatic and thus heat transfer is negligible.

Properties From the refrigerant tables (Table A-13)

$$\left. \begin{array}{l} P_1 = 700 \text{ kPa} \\ T_1 = 120^\circ\text{C} \end{array} \right\} \begin{array}{l} \nu_1 = 0.043358 \text{ m}^3/\text{kg} \\ h_1 = 358.92 \text{ kJ/kg} \end{array}$$

and

$$\left. \begin{array}{l} P_2 = 400 \text{ kPa} \\ T_2 = 30^\circ\text{C} \end{array} \right\} \begin{array}{l} \nu_2 = 0.056796 \text{ m}^3/\text{kg} \\ h_2 = 275.09 \text{ kJ/kg} \end{array}$$

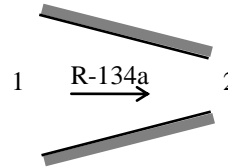

Analysis (a) There is only one inlet and one exit, and thus $\dot{m}_1 = \dot{m}_2 = \dot{m}$. We take nozzle as the system, which is a control volume since mass crosses the boundary. The energy balance for this steady-flow system can be expressed in the rate form as

$$\underbrace{\dot{E}_{\text{in}} - \dot{E}_{\text{out}}}_{\text{Rate of net energy transfer by heat, work, and mass}} = \underbrace{\Delta \dot{E}_{\text{system}}}_{\text{Rate of change in internal, kinetic, potential, etc. energies}} \stackrel{\approx 0 \text{ (steady)}}{=} 0$$

$$\dot{E}_{\text{in}} = \dot{E}_{\text{out}}$$

$$\dot{m}(h_1 + V_1^2/2) = \dot{m}(h_2 + V_2^2/2) \quad (\text{since } \dot{Q} \cong \dot{W} \cong \Delta \text{pe} \cong 0)$$

$$0 = h_2 - h_1 + \frac{V_2^2 - V_1^2}{2}$$

Substituting,

$$0 = (275.09 - 358.92) \text{ kJ/kg} + \frac{V_2^2 - (20 \text{ m/s})^2}{2} \left(\frac{1 \text{ kJ/kg}}{1000 \text{ m}^2/\text{s}^2} \right)$$

It yields

$$V_2 = \mathbf{409.9 \text{ m/s}}$$

(b) The ratio of the inlet to exit area is determined from the conservation of mass relation,

$$\frac{1}{\nu_2} A_2 V_2 = \frac{1}{\nu_1} A_1 V_1 \longrightarrow \frac{A_1}{A_2} = \frac{\nu_1}{\nu_2} \frac{V_2}{V_1} = \frac{(0.043358 \text{ m}^3/\text{kg})(409.9 \text{ m/s})}{(0.056796 \text{ m}^3/\text{kg})(20 \text{ m/s})} = \mathbf{15.65}$$

5-35 Nitrogen is decelerated in a diffuser from 275 m/s to a lower velocity. The exit velocity of nitrogen and the ratio of the inlet-to-exit area are to be determined.

Assumptions 1 This is a steady-flow process since there is no change with time. **2** Nitrogen is an ideal gas with variable specific heats. **3** Potential energy changes are negligible. **4** The device is adiabatic and thus heat transfer is negligible. **5** There are no work interactions.

Properties The molar mass of nitrogen is $M = 28$ kg/kmol (Table A-1). The enthalpies are (Table A-18)

$$T_1 = 7^\circ\text{C} = 280 \text{ K} \rightarrow \bar{h}_1 = 8141 \text{ kJ/kmol}$$

$$T_2 = 27^\circ\text{C} = 300 \text{ K} \rightarrow \bar{h}_2 = 8723 \text{ kJ/kmol}$$

Analysis (a) There is only one inlet and one exit, and thus $\dot{m}_1 = \dot{m}_2 = \dot{m}$. We take diffuser as the system, which is a control volume since mass crosses the boundary. The energy balance for this steady-flow system can be expressed in the rate form as

$$\underbrace{\dot{E}_{\text{in}} - \dot{E}_{\text{out}}}_{\substack{\text{Rate of net energy transfer} \\ \text{by heat, work, and mass}}} = \underbrace{\Delta \dot{E}_{\text{system}}}_{\substack{\text{Rate of change in internal, kinetic,} \\ \text{potential, etc. energies}}} \stackrel{\text{no (steady)}}{=} 0$$

$$\dot{E}_{\text{in}} = \dot{E}_{\text{out}}$$

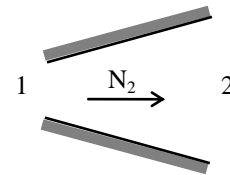

$$\dot{m}(h_1 + V_1^2/2) = \dot{m}(h_2 + V_2^2/2) \quad (\text{since } \dot{Q} \cong \dot{W} \cong \Delta p_e \cong 0)$$

$$0 = h_2 - h_1 + \frac{V_2^2 - V_1^2}{2} = \frac{\bar{h}_2 - \bar{h}_1}{M} + \frac{V_2^2 - V_1^2}{2}$$

Substituting,

$$0 = \frac{(8723 - 8141) \text{ kJ/kmol}}{28 \text{ kg/kmol}} + \frac{V_2^2 - (275 \text{ m/s})^2}{2} \left(\frac{1 \text{ kJ/kg}}{1000 \text{ m}^2/\text{s}^2} \right)$$

It yields

$$V_2 = \mathbf{185 \text{ m/s}}$$

(b) The ratio of the inlet to exit area is determined from the conservation of mass relation,

$$\frac{1}{\nu_2} A_2 V_2 = \frac{1}{\nu_1} A_1 V_1 \longrightarrow \frac{A_1}{A_2} = \frac{\nu_1}{\nu_2} \frac{V_2}{V_1} = \left(\frac{RT_1/P_1}{RT_2/P_2} \right) \frac{V_2}{V_1}$$

or,

$$\frac{A_1}{A_2} = \left(\frac{T_1/P_1}{T_2/P_2} \right) \frac{V_2}{V_1} = \frac{(280 \text{ K}/60 \text{ kPa})(185 \text{ m/s})}{(300 \text{ K}/85 \text{ kPa})(200 \text{ m/s})} = \mathbf{0.887}$$



5-36 Problem 5-35 is reconsidered. The effect of the inlet velocity on the exit velocity and the ratio of the inlet-to-exit area as the inlet velocity varies from 210 m/s to 350 m/s is to be investigated. The final results are to be plotted against the inlet velocity.

Analysis The problem is solved using EES, and the solution is given below.

Function HCal(WorkFluid\$, Tx, Px)

"Function to calculate the enthalpy of an ideal gas or real gas"

If 'N2' = WorkFluid\$ then

HCal:=ENTHALPY(WorkFluid\$,T=Tx) "Ideal gas equ."

else

HCal:=ENTHALPY(WorkFluid\$,T=Tx, P=Px)"Real gas equ."

endif

end HCal

"System: control volume for the nozzle"

"Property relation: Nitrogen is an ideal gas"

"Process: Steady state, steady flow, adiabatic, no work"

"Knowns"

WorkFluid\$ = 'N2'

T[1] = 7 [C]

P[1] = 60 [kPa]

"Vel[1] = 275 [m/s]"

P[2] = 85 [kPa]

T[2] = 27 [C]

"Property Data - since the Enthalpy function has different parameters for ideal gas and real fluids, a function was used to determine h."

h[1]=HCal(WorkFluid\$,T[1],P[1])

h[2]=HCal(WorkFluid\$,T[2],P[2])

"The Volume function has the same form for an ideal gas as for a real fluid."

v[1]=volume(workFluid\$,T=T[1],p=P[1])

v[2]=volume(WorkFluid\$,T=T[2],p=P[2])

"From the definition of mass flow rate, $m_{\dot{}} = A \cdot \text{Vel} / v$ and conservation of mass the area ratio $A_{\text{Ratio}} = A_1 / A_2$ is:"

$A_{\text{Ratio}} \cdot \text{Vel}[1] / v[1] = \text{Vel}[2] / v[2]$

"Conservation of Energy - SSSF energy balance"

$h[1] + \text{Vel}[1]^2 / (2 \cdot 1000) = h[2] + \text{Vel}[2]^2 / (2 \cdot 1000)$

Vel ₁ [m/s]	Vel ₂ [m/s]	A _{Ratio}
210	50.01	0.3149
224	92.61	0.5467
238	122.7	0.6815
252	148	0.7766
266	170.8	0.8488
280	191.8	0.9059
294	211.7	0.9523
308	230.8	0.9908
322	249.2	1.023
336	267	1.051
350	284.4	1.075

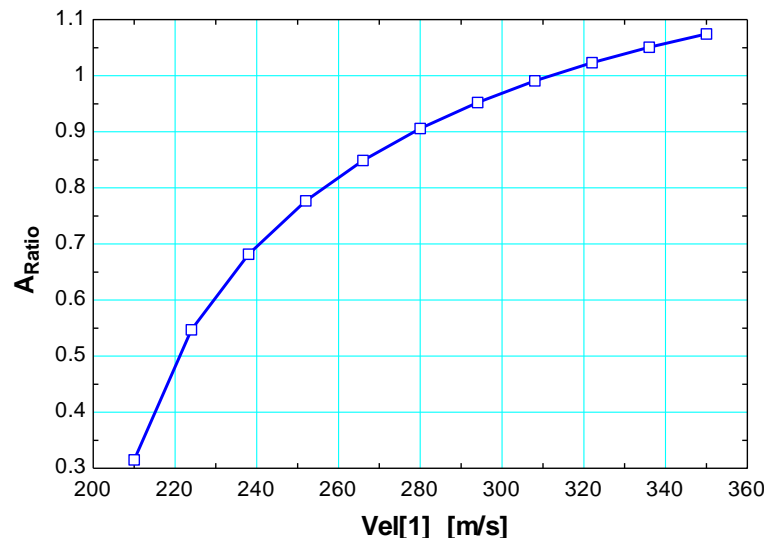
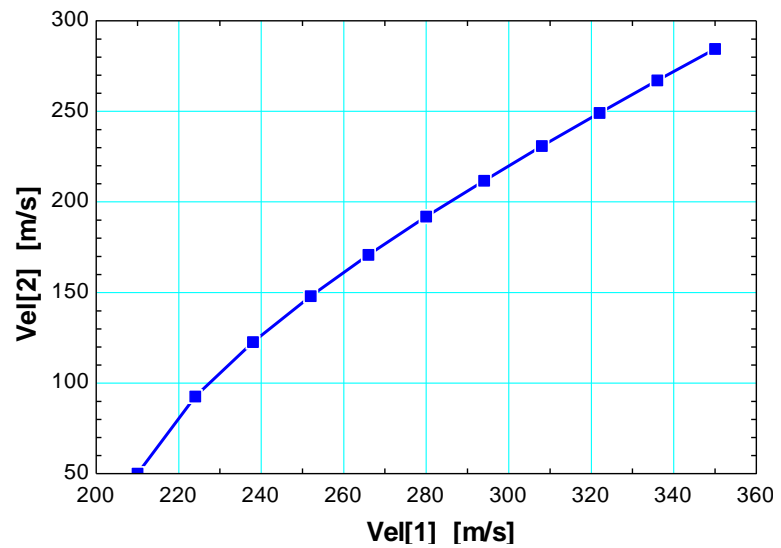

5-37 R-134a is decelerated in a diffuser from a velocity of 160 m/s. The exit velocity of R-134a and the mass flow rate of the R-134a are to be determined.

Assumptions 1 This is a steady-flow process since there is no change with time. **2** Potential energy changes are negligible. **3** There are no work interactions.

Properties From the R-134a tables (Tables A-11 through A-13)

$$\left. \begin{array}{l} P_1 = 600 \text{ kPa} \\ \text{sat. vapor} \end{array} \right\} \begin{array}{l} v_1 = 0.034335 \text{ m}^3/\text{kg} \\ h_1 = 262.46 \text{ kJ/kg} \end{array}$$

and

$$\left. \begin{array}{l} P_2 = 700 \text{ kPa} \\ T_2 = 40^\circ\text{C} \end{array} \right\} \begin{array}{l} v_2 = 0.031696 \text{ m}^3/\text{kg} \\ h_2 = 278.59 \text{ kJ/kg} \end{array}$$

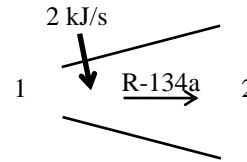

Analysis (a) There is only one inlet and one exit, and thus $\dot{m}_1 = \dot{m}_2 = \dot{m}$. Then the exit velocity of R-134a is determined from the steady-flow mass balance to be

$$\frac{1}{v_2} A_2 V_2 = \frac{1}{v_1} A_1 V_1 \longrightarrow V_2 = \frac{v_2}{v_1} \frac{A_1}{A_2} V_1 = \frac{1}{1.8} \frac{(0.031696 \text{ m}^3/\text{kg})}{(0.034335 \text{ m}^3/\text{kg})} (160 \text{ m/s}) = \mathbf{82.06 \text{ m/s}}$$

(b) We take diffuser as the system, which is a control volume since mass crosses the boundary. The energy balance for this steady-flow system can be expressed in the rate form as

$$\underbrace{\dot{E}_{\text{in}} - \dot{E}_{\text{out}}}_{\substack{\text{Rate of net energy transfer} \\ \text{by heat, work, and mass}}} = \underbrace{\Delta \dot{E}_{\text{system}}}_{\substack{\text{Rate of change in internal, kinetic,} \\ \text{potential, etc. energies}}} \stackrel{\text{no (steady)}}{=} 0$$

$$\dot{E}_{\text{in}} = \dot{E}_{\text{out}}$$

$$\dot{Q}_{\text{in}} + \dot{m}(h_1 + V_1^2/2) = \dot{m}(h_2 + V_2^2/2) \quad (\text{since } \dot{W} \cong \Delta \text{pe} \cong 0)$$

$$\dot{Q}_{\text{in}} = \dot{m} \left(h_2 - h_1 + \frac{V_2^2 - V_1^2}{2} \right)$$

Substituting, the mass flow rate of the refrigerant is determined to be

$$2 \text{ kJ/s} = \dot{m} \left[(278.59 - 262.46) \text{ kJ/kg} + \frac{(82.06 \text{ m/s})^2 - (160 \text{ m/s})^2}{2} \left(\frac{1 \text{ kJ/kg}}{1000 \text{ m}^2/\text{s}^2} \right) \right]$$

It yields

$$\dot{m} = \mathbf{0.2984 \text{ kg/s}}$$

5-38 Steam is accelerated in a nozzle from a velocity of 60 m/s. The mass flow rate, the exit velocity, and the exit area of the nozzle are to be determined.

Assumptions 1 This is a steady-flow process since there is no change with time. **2** Potential energy changes are negligible. **3** There are no work interactions.

Properties From the steam tables (Table A-6)

$$\left. \begin{array}{l} P_1 = 4 \text{ MPa} \\ T_1 = 400^\circ\text{C} \end{array} \right\} \begin{array}{l} \nu_1 = 0.07343 \text{ m}^3/\text{kg} \\ h_1 = 3214.5 \text{ kJ/kg} \end{array}$$

and

$$\left. \begin{array}{l} P_2 = 2 \text{ MPa} \\ T_2 = 300^\circ\text{C} \end{array} \right\} \begin{array}{l} \nu_2 = 0.12551 \text{ m}^3/\text{kg} \\ h_2 = 3024.2 \text{ kJ/kg} \end{array}$$

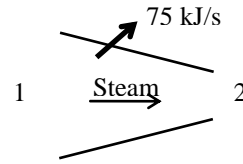

Analysis (a) There is only one inlet and one exit, and thus $\dot{m}_1 = \dot{m}_2 = \dot{m}$. The mass flow rate of steam is

$$\dot{m} = \frac{1}{\nu_1} V_1 A_1 = \frac{1}{0.07343 \text{ m}^3/\text{kg}} (60 \text{ m/s})(50 \times 10^{-4} \text{ m}^2) = \mathbf{4.085 \text{ kg/s}}$$

(b) We take nozzle as the system, which is a control volume since mass crosses the boundary. The energy balance for this steady-flow system can be expressed in the rate form as

$$\underbrace{\dot{E}_{\text{in}} - \dot{E}_{\text{out}}}_{\text{Rate of net energy transfer by heat, work, and mass}} = \underbrace{\Delta \dot{E}_{\text{system}}}_{\text{Rate of change in internal, kinetic, potential, etc. energies}} \stackrel{\text{no (steady)}}{=} 0$$

$$\dot{E}_{\text{in}} = \dot{E}_{\text{out}}$$

$$\dot{m}(h_1 + V_1^2/2) = \dot{Q}_{\text{out}} + \dot{m}(h_2 + V_2^2/2) \quad (\text{since } \dot{W} \cong \Delta \text{pe} \cong 0)$$

$$-\dot{Q}_{\text{out}} = \dot{m} \left(h_2 - h_1 + \frac{V_2^2 - V_1^2}{2} \right)$$

Substituting, the exit velocity of the steam is determined to be

$$-75 \text{ kJ/s} = (4.085 \text{ kg/s}) \left(3024.2 - 3214.5 + \frac{V_2^2 - (60 \text{ m/s})^2}{2} \left(\frac{1 \text{ kJ/kg}}{1000 \text{ m}^2/\text{s}^2} \right) \right)$$

It yields

$$V_2 = \mathbf{589.5 \text{ m/s}}$$

(c) The exit area of the nozzle is determined from

$$\dot{m} = \frac{1}{\nu_2} V_2 A_2 \longrightarrow A_2 = \frac{\dot{m} \nu_2}{V_2} = \frac{(4.085 \text{ kg/s})(0.12551 \text{ m}^3/\text{kg})}{589.5 \text{ m/s}} = \mathbf{8.70 \times 10^{-4} \text{ m}^2}$$

5-39 Air is decelerated in a diffuser from 220 m/s. The exit velocity and the exit pressure of air are to be determined.

Assumptions 1 This is a steady-flow process since there is no change with time. **2** Air is an ideal gas with variable specific heats. **3** Potential energy changes are negligible. **4** There are no work interactions.

Properties The gas constant of air is $0.287 \text{ kPa}\cdot\text{m}^3/\text{kg}\cdot\text{K}$ (Table A-1). The enthalpies are (Table A-17)

$$T_1 = 27^\circ\text{C} = 300 \text{ K} \rightarrow h_1 = 300.19 \text{ kJ/kg}$$

$$T_2 = 42^\circ\text{C} = 315 \text{ K} \rightarrow h_2 = 315.27 \text{ kJ/kg}$$

Analysis (a) There is only one inlet and one exit, and thus $\dot{m}_1 = \dot{m}_2 = \dot{m}$. We take diffuser as the system, which is a control volume since mass crosses the boundary. The energy balance for this steady-flow system can be expressed in the rate form as

$$\underbrace{\dot{E}_{\text{in}} - \dot{E}_{\text{out}}}_{\text{Rate of net energy transfer by heat, work, and mass}} = \underbrace{\Delta\dot{E}_{\text{system}}}_{\text{Rate of change in internal, kinetic, potential, etc. energies}} \stackrel{\text{no (steady)}}{=} 0$$

$$\dot{E}_{\text{in}} = \dot{E}_{\text{out}}$$

$$\dot{m}(h_1 + V_1^2/2) = \dot{Q}_{\text{out}} + \dot{m}(h_2 + V_2^2/2) \quad (\text{since } \dot{W} \equiv \Delta\text{pe} \equiv 0)$$

$$-\dot{Q}_{\text{out}} = \dot{m} \left(h_2 - h_1 + \frac{V_2^2 - V_1^2}{2} \right)$$

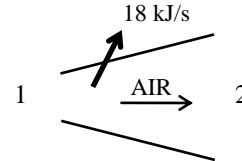

Substituting, the exit velocity of the air is determined to be

$$-18 \text{ kJ/s} = (2.5 \text{ kg/s}) \left((315.27 - 300.19) \text{ kJ/kg} + \frac{V_2^2 - (220 \text{ m/s})^2}{2} \left(\frac{1 \text{ kJ/kg}}{1000 \text{ m}^2/\text{s}^2} \right) \right)$$

It yields $V_2 = 62.0 \text{ m/s}$

(b) The exit pressure of air is determined from the conservation of mass and the ideal gas relations,

$$\dot{m} = \frac{1}{v_2} A_2 V_2 \longrightarrow v_2 = \frac{A_2 V_2}{\dot{m}} = \frac{(0.04 \text{ m}^2)(62 \text{ m/s})}{2.5 \text{ kg/s}} = 0.992 \text{ m}^3/\text{kg}$$

and

$$P_2 v_2 = RT_2 \longrightarrow P_2 = \frac{RT_2}{v_2} = \frac{(0.287 \text{ kPa}\cdot\text{m}^3/\text{kg}\cdot\text{K})(315 \text{ K})}{0.992 \text{ m}^3/\text{kg}} = 91.1 \text{ kPa}$$

Turbines and Compressors

5-40C The volume flow rate at the compressor inlet will be greater than that at the compressor exit.

5-41C Yes. Because energy (in the form of shaft work) is being added to the air.

5-42C No.

5-43E Air expands in a turbine. The mass flow rate of air and the power output of the turbine are to be determined.

Assumptions 1 This is a steady-flow process since there is no change with time. **2** Potential energy changes are negligible. **3** The device is adiabatic and thus heat transfer is negligible. **4** Air is an ideal gas with constant specific heats.

Properties The gas constant of air is $R = 0.3704 \text{ psia}\cdot\text{ft}^3/\text{lbm}\cdot\text{R}$. The constant pressure specific heat of air at the average temperature of $(900 + 300)/2 = 600^\circ\text{F}$ is $c_p = 0.25 \text{ Btu}/\text{lbm}\cdot^\circ\text{F}$ (Table A-2a)

Analysis (a) There is only one inlet and one exit, and thus $\dot{m}_1 = \dot{m}_2 = \dot{m}$. The inlet specific volume of air and its mass flow rate are

$$v_1 = \frac{RT_1}{P_1} = \frac{(0.3704 \text{ psia}\cdot\text{ft}^3/\text{lbm}\cdot\text{R})(1360 \text{ R})}{150 \text{ psia}} = 3.358 \text{ ft}^3/\text{lbm}$$

$$\dot{m} = \frac{1}{v_1} A_1 V_1 = \frac{1}{3.358 \text{ ft}^3/\text{lbm}} (0.1 \text{ ft}^2)(350 \text{ ft/s}) = \mathbf{10.42 \text{ lbm/s}}$$

(b) We take the turbine as the system, which is a control volume since mass crosses the boundary. The energy balance for this steady-flow system can be expressed in the rate form as

$$\underbrace{\dot{E}_{\text{in}} - \dot{E}_{\text{out}}}_{\text{Rate of net energy transfer by heat, work, and mass}} = \underbrace{\Delta\dot{E}_{\text{system}}}_{\text{Rate of change in internal, kinetic, potential, etc. energies}} \stackrel{\text{no (steady)}}{=} 0$$

$$\dot{E}_{\text{in}} = \dot{E}_{\text{out}}$$

$$\dot{m}(h_1 + V_1^2/2) = \dot{W}_{\text{out}} + \dot{m}(h_2 + V_2^2/2) \quad (\text{since } \dot{Q} \cong \Delta p_e \cong 0)$$

$$\dot{W}_{\text{out}} = -\dot{m} \left(h_2 - h_1 + \frac{V_2^2 - V_1^2}{2} \right) = -\dot{m} \left(c_p(T_2 - T_1) + \frac{V_2^2 - V_1^2}{2} \right)$$

Substituting,

$$\begin{aligned} \dot{W}_{\text{out}} &= -(10.42 \text{ lbm/s}) \left[(0.250 \text{ Btu}/\text{lbm}\cdot^\circ\text{F})(300 - 900)^\circ\text{F} + \frac{(700 \text{ ft/s})^2 - (350 \text{ ft/s})^2}{2} \left(\frac{1 \text{ Btu}/\text{lbm}}{25,037 \text{ ft}^2/\text{s}^2} \right) \right] \\ &= 1486.5 \text{ Btu/s} = \mathbf{1568 \text{ kW}} \end{aligned}$$

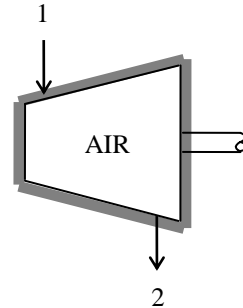

5-44 Refrigerant-134a is compressed steadily by a compressor. The power input to the compressor and the volume flow rate of the refrigerant at the compressor inlet are to be determined.

Assumptions 1 This is a steady-flow process since there is no change with time. **2** Kinetic and potential energy changes are negligible. **3** The device is adiabatic and thus heat transfer is negligible.

Properties From the refrigerant tables (Tables A-11 through 13)

$$\left. \begin{array}{l} T_1 = -24^\circ\text{C} \\ \text{sat.vapor} \end{array} \right\} \left. \begin{array}{l} v_1 = 0.17398 \text{ m}^3/\text{kg} \\ h_1 = 235.94 \text{ kJ/kg} \end{array} \right\} \left. \begin{array}{l} P_2 = 0.8 \text{ MPa} \\ T_2 = 60^\circ\text{C} \end{array} \right\} h_2 = 296.82 \text{ kJ/kg}$$

Analysis (a) There is only one inlet and one exit, and thus $\dot{m}_1 = \dot{m}_2 = \dot{m}$. We take the compressor as the system, which is a control volume since mass crosses the boundary. The energy balance for this steady-flow system can be expressed in the rate form as

$$\underbrace{\dot{E}_{\text{in}} - \dot{E}_{\text{out}}}_{\text{Rate of net energy transfer by heat, work, and mass}} = \underbrace{\Delta \dot{E}_{\text{system}}}_{\text{Rate of change in internal, kinetic, potential, etc. energies}} \stackrel{\text{no (steady)}}{=} 0$$

$$\dot{E}_{\text{in}} = \dot{E}_{\text{out}}$$

$$\dot{W}_{\text{in}} + \dot{m}h_1 = \dot{m}h_2 \quad (\text{since } \dot{Q} \cong \Delta ke \cong \Delta pe \cong 0)$$

$$\dot{W}_{\text{in}} = \dot{m}(h_2 - h_1)$$

Substituting,

$$\dot{W}_{\text{in}} = (1.2 \text{ kg/s})(296.82 - 235.94) \text{ kJ/kg} = \mathbf{73.06 \text{ kJ/s}}$$

(b) The volume flow rate of the refrigerant at the compressor inlet is

$$\dot{V}_1 = \dot{m}v_1 = (1.2 \text{ kg/s})(0.17398 \text{ m}^3/\text{kg}) = \mathbf{0.209 \text{ m}^3/\text{s}}$$

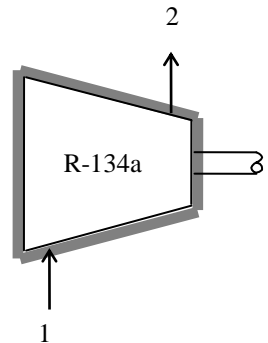

5-45 Saturated R-134a vapor is compressed to a specified state. The power input is given. The exit temperature is to be determined.

Assumptions 1 This is a steady-flow process since there is no change with time. **2** Kinetic and potential energy changes are negligible. **3** Heat transfer with the surroundings is negligible.

Analysis We take the compressor as the system, which is a control volume since mass crosses the boundary. Noting that one fluid stream enters and leaves the compressor, the energy balance for this steady-flow system can be expressed in the rate form as

$$\underbrace{\dot{E}_{\text{in}} - \dot{E}_{\text{out}}}_{\text{Rate of net energy transfer by heat, work, and mass}} = \underbrace{\Delta \dot{E}_{\text{system}}^{\text{0 (steady)}}}_{\text{Rate of change in internal, kinetic, potential, etc. energies}} = 0$$

$$\dot{E}_{\text{in}} = \dot{E}_{\text{out}}$$

$$\dot{W}_{\text{in}} + \dot{m}h_1 = \dot{m}h_2 \quad (\text{since } \Delta ke \cong \Delta pe \cong 0)$$

$$\dot{W}_{\text{in}} = \dot{m}(h_2 - h_1)$$

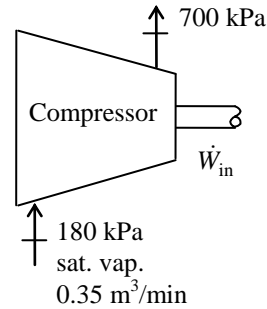

From R134a tables (Table A-12)

$$\left. \begin{array}{l} P_1 = 180 \text{ kPa} \\ x_1 = 0 \end{array} \right\} \begin{array}{l} h_1 = 242.90 \text{ kJ/kg} \\ v_1 = 0.1105 \text{ m}^3/\text{kg} \end{array}$$

The mass flow rate is

$$\dot{m} = \frac{\dot{V}_1}{v_1} = \frac{(0.35/60) \text{ m}^3/\text{s}}{0.1104 \text{ m}^3/\text{kg}} = 0.05283 \text{ kg/s}$$

Substituting for the exit enthalpy,

$$\dot{W}_{\text{in}} = \dot{m}(h_2 - h_1)$$

$$2.35 \text{ kW} = (0.05283 \text{ kg/s})(h_2 - 242.90) \text{ kJ/kg} \longrightarrow h_2 = 287.41 \text{ kJ/kg}$$

From Table A-13,

$$\left. \begin{array}{l} P_2 = 700 \text{ kPa} \\ h_2 = 287.41 \text{ kJ/kg} \end{array} \right\} T_2 = \mathbf{48.9^\circ\text{C}}$$

5-46 Steam expands in a turbine. The change in kinetic energy, the power output, and the turbine inlet area are to be determined.

Assumptions 1 This is a steady-flow process since there is no change with time. **2** Potential energy changes are negligible. **3** The device is adiabatic and thus heat transfer is negligible.

Properties From the steam tables (Tables A-4 through 6)

$$\left. \begin{array}{l} P_1 = 4 \text{ MPa} \\ T_1 = 500^\circ\text{C} \end{array} \right\} \begin{array}{l} \nu_1 = 0.086442 \text{ m}^3/\text{kg} \\ h_1 = 3446.0 \text{ kJ/kg} \end{array}$$

and

$$\left. \begin{array}{l} P_2 = 30 \text{ kPa} \\ x_2 = 0.92 \end{array} \right\} h_2 = h_f + x_2 h_{fg} = 289.27 + 0.92 \times 2335.3 = 2437.7 \text{ kJ/kg}$$

Analysis (a) The change in kinetic energy is determined from

$$\Delta ke = \frac{V_2^2 - V_1^2}{2} = \frac{(50 \text{ m/s})^2 - (80 \text{ m/s})^2}{2} \left(\frac{1 \text{ kJ/kg}}{1000 \text{ m}^2/\text{s}^2} \right) = \mathbf{-1.95 \text{ kJ/kg}}$$

(b) There is only one inlet and one exit, and thus $\dot{m}_1 = \dot{m}_2 = \dot{m}$. We take the turbine as the system, which is a control volume since mass crosses the boundary. The energy balance for this steady-flow system can be expressed in the rate form as

$$\underbrace{\dot{E}_{\text{in}} - \dot{E}_{\text{out}}}_{\substack{\text{Rate of net energy transfer} \\ \text{by heat, work, and mass}}} = \underbrace{\Delta \dot{E}_{\text{system}}}_{\substack{\text{Rate of change in internal, kinetic,} \\ \text{potential, etc. energies}}} \stackrel{\text{no (steady)}}{=} 0$$

$$\dot{E}_{\text{in}} = \dot{E}_{\text{out}}$$

$$\dot{m}(h_1 + V_1^2/2) = \dot{W}_{\text{out}} + \dot{m}(h_2 + V_2^2/2) \quad (\text{since } \dot{Q} \cong \Delta pe \cong 0)$$

$$\dot{W}_{\text{out}} = -\dot{m} \left(h_2 - h_1 + \frac{V_2^2 - V_1^2}{2} \right)$$

Then the power output of the turbine is determined by substitution to be

$$\dot{W}_{\text{out}} = -(12 \text{ kg/s})(2437.7 - 3446.0 - 1.95) \text{ kJ/kg} = 12,123 \text{ kW} = \mathbf{12.1 \text{ MW}}$$

(c) The inlet area of the turbine is determined from the mass flow rate relation,

$$\dot{m} = \frac{1}{\nu_1} A_1 V_1 \longrightarrow A_1 = \frac{\dot{m} \nu_1}{V_1} = \frac{(12 \text{ kg/s})(0.086442 \text{ m}^3/\text{kg})}{80 \text{ m/s}} = \mathbf{0.0130 \text{ m}^2}$$

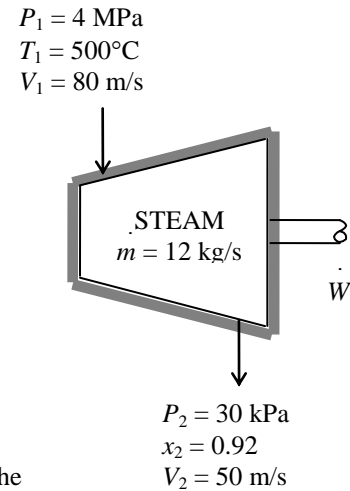



5-47 Problem 5-46 is reconsidered. The effect of the turbine exit pressure on the power output of the turbine as the exit pressure varies from 10 kPa to 200 kPa is to be investigated. The power output is to be plotted against the exit pressure.

Analysis The problem is solved using EES, and the solution is given below.

"Knowns "

T[1] = 500 [C]
 P[1] = 4000 [kPa]
 Vel[1] = 80 [m/s]
 P[2] = 30 [kPa]
 X_2=0.92
 Vel[2] = 50 [m/s]
 m_dot[1]=12 [kg/s]
 Fluid\$='Steam_IAPWS'

"Property Data"

h[1]=enthalpy(Fluid\$,T=T[1],P=P[1])
 h[2]=enthalpy(Fluid\$,P=P[2],x=x_2)
 T[2]=temperature(Fluid\$,P=P[2],x=x_2)
 v[1]=volume(Fluid\$,T=T[1],p=P[1])
 v[2]=volume(Fluid\$,P=P[2],x=x_2)

"Conservation of mass: "

m_dot[1]= m_dot[2]

"Mass flow rate"

m_dot[1]=A[1]*Vel[1]/v[1]
 m_dot[2]= A[2]*Vel[2]/v[2]

"Conservation of Energy - Steady Flow energy balance"

m_dot[1]*(h[1]+Vel[1]^2/2*Convert(m^2/s^2, kJ/kg)) = m_dot[2]*(h[2]+Vel[2]^2/2*Convert(m^2/s^2, kJ/kg))+W_dot_turb*convert(MW,kJ/s)
 DELTAke=Vel[2]^2/2*Convert(m^2/s^2, kJ/kg)-Vel[1]^2/2*Convert(m^2/s^2, kJ/kg)

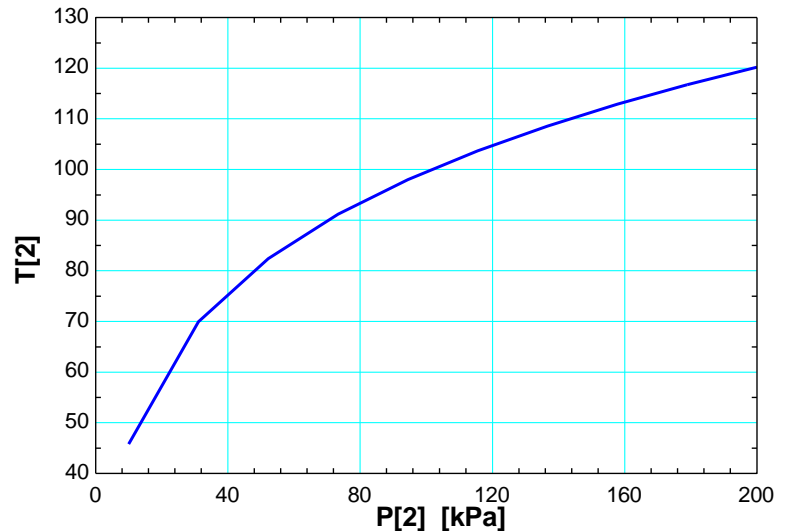

P ₂ [kPa]	W _{turb} [MW]	T ₂ [C]
10	12.67	45.81
31.11	12.1	69.93
52.22	11.82	82.4
73.33	11.63	91.16
94.44	11.48	98.02
115.6	11.36	103.7
136.7	11.25	108.6
157.8	11.16	112.9
178.9	11.08	116.7
200	11.01	120.2

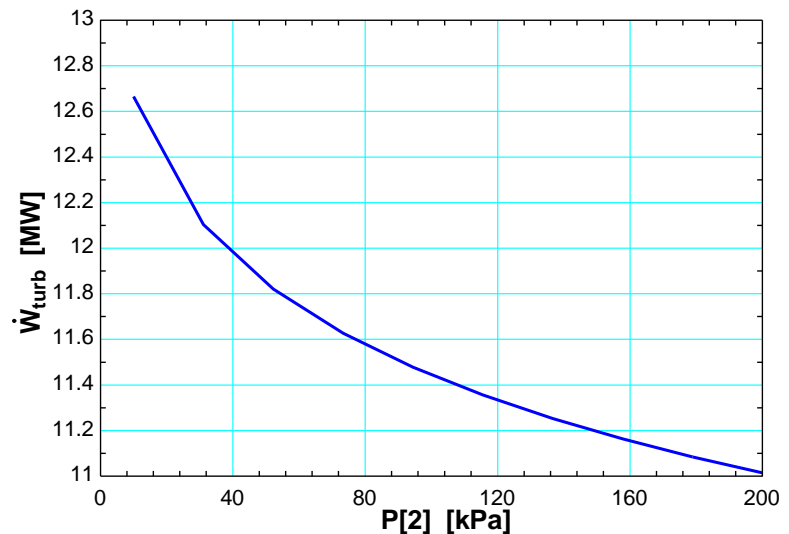

5-48 Steam expands in a turbine. The mass flow rate of steam for a power output of 5 MW is to be determined.

Assumptions 1 This is a steady-flow process since there is no change with time. **2** Kinetic and potential energy changes are negligible. **3** The device is adiabatic and thus heat transfer is negligible.

Properties From the steam tables (Tables A-4 through 6)

$$\left. \begin{array}{l} P_1 = 10 \text{ MPa} \\ T_1 = 500^\circ\text{C} \end{array} \right\} h_1 = 3375.1 \text{ kJ/kg}$$

$$\left. \begin{array}{l} P_2 = 10 \text{ kPa} \\ x_2 = 0.90 \end{array} \right\} h_2 = h_f + x_2 h_{fg} = 191.81 + 0.90 \times 2392.1 = 2344.7 \text{ kJ/kg}$$

Analysis There is only one inlet and one exit, and thus $\dot{m}_1 = \dot{m}_2 = \dot{m}$. We take the turbine as the system, which is a control volume since mass crosses the boundary. The energy balance for this steady-flow system can be expressed in the rate form as

$$\underbrace{\dot{E}_{\text{in}} - \dot{E}_{\text{out}}}_{\text{Rate of net energy transfer by heat, work, and mass}} = \underbrace{\dot{\Delta E}_{\text{system}}}_{\text{Rate of change in internal, kinetic, potential, etc. energies}} \stackrel{\text{no (steady)}}{=} 0$$

$$\dot{E}_{\text{in}} = \dot{E}_{\text{out}}$$

$$\dot{m}h_1 = \dot{W}_{\text{out}} + \dot{m}h_2 \quad (\text{since } \dot{Q} \cong \Delta ke \cong \Delta pe \cong 0)$$

$$\dot{W}_{\text{out}} = -\dot{m}(h_2 - h_1)$$

Substituting, the required mass flow rate of the steam is determined to be

$$5000 \text{ kJ/s} = -\dot{m}(2344.7 - 3375.1) \text{ kJ/kg} \longrightarrow \dot{m} = \mathbf{4.852 \text{ kg/s}}$$

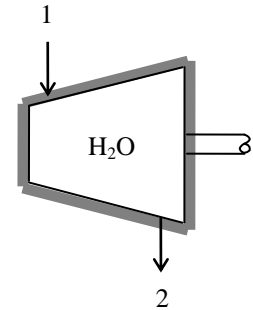

5-49E Steam expands in a turbine. The rate of heat loss from the steam for a power output of 4 MW is to be determined.

Assumptions 1 This is a steady-flow process since there is no change with time. **2** Kinetic and potential energy changes are negligible.

Properties From the steam tables (Tables A-4E through 6E)

$$\left. \begin{array}{l} P_1 = 1000 \text{ psia} \\ T_1 = 900^\circ\text{F} \end{array} \right\} h_1 = 1448.6 \text{ Btu/lbm}$$

$$\left. \begin{array}{l} P_2 = 5 \text{ psia} \\ \text{sat. vapor} \end{array} \right\} h_2 = 1130.7 \text{ Btu/lbm}$$

Analysis There is only one inlet and one exit, and thus $\dot{m}_1 = \dot{m}_2 = \dot{m}$. We take the turbine as the system, which is a control volume since mass crosses the boundary. The energy balance for this steady-flow system can be expressed in the rate form as

$$\underbrace{\dot{E}_{\text{in}} - \dot{E}_{\text{out}}}_{\text{Rate of net energy transfer by heat, work, and mass}} = \underbrace{\dot{\Delta E}_{\text{system}}}_{\text{Rate of change in internal, kinetic, potential, etc. energies}} \stackrel{\text{no (steady)}}{=} 0$$

$$\dot{E}_{\text{in}} = \dot{E}_{\text{out}}$$

$$\dot{m}h_1 = \dot{Q}_{\text{out}} + \dot{W}_{\text{out}} + \dot{m}h_2 \quad (\text{since } \Delta ke \cong \Delta pe \cong 0)$$

$$\dot{Q}_{\text{out}} = -\dot{m}(h_2 - h_1) - \dot{W}_{\text{out}}$$

Substituting,

$$\dot{Q}_{\text{out}} = -(45000/3600 \text{ lbm/s})(1130.7 - 1448.6) \text{ Btu/lbm} - 4000 \text{ kJ/s} \left(\frac{1 \text{ Btu}}{1.055 \text{ kJ}} \right) = \mathbf{182.0 \text{ Btu/s}}$$

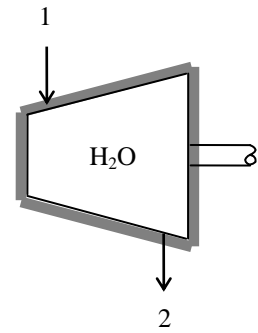

5-50 Helium is compressed by a compressor. For a mass flow rate of 60 kg/min, the power input required is to be determined.

Assumptions 1 This is a steady-flow process since there is no change with time. **2** Kinetic and potential energy changes are negligible. **3** Helium is an ideal gas with constant specific heats.

Properties The constant pressure specific heat of helium is $c_p = 5.1926 \text{ kJ/kg}\cdot\text{K}$ (Table A-2a).

Analysis There is only one inlet and one exit, and thus $\dot{m}_1 = \dot{m}_2 = \dot{m}$. We take the compressor as the system, which is a control volume since mass crosses the boundary. The energy balance for this steady-flow system can be expressed in the rate form as

$$\underbrace{\dot{E}_{\text{in}} - \dot{E}_{\text{out}}}_{\substack{\text{Rate of net energy transfer} \\ \text{by heat, work, and mass}}} = \underbrace{\Delta \dot{E}_{\text{system}}}_{\substack{\text{Rate of change in internal, kinetic,} \\ \text{potential, etc. energies}}} \stackrel{\approx 0 \text{ (steady)}}{=} 0$$

$$\dot{E}_{\text{in}} = \dot{E}_{\text{out}}$$

$$\dot{W}_{\text{in}} + \dot{m}h_1 = \dot{Q}_{\text{out}} + \dot{m}h_2 \quad (\text{since } \Delta \text{ke} \cong \Delta \text{pe} \cong 0)$$

$$\dot{W}_{\text{in}} - \dot{Q}_{\text{out}} = \dot{m}(h_2 - h_1) = \dot{m}c_p(T_2 - T_1)$$

Thus,

$$\begin{aligned} \dot{W}_{\text{in}} &= \dot{Q}_{\text{out}} + \dot{m}c_p(T_2 - T_1) \\ &= (60/60 \text{ kg/s})(15 \text{ kJ/kg}) + (60/60 \text{ kg/s})(5.1926 \text{ kJ/kg}\cdot\text{K})(460 - 295)\text{K} \\ &= \mathbf{872 \text{ kW}} \end{aligned}$$

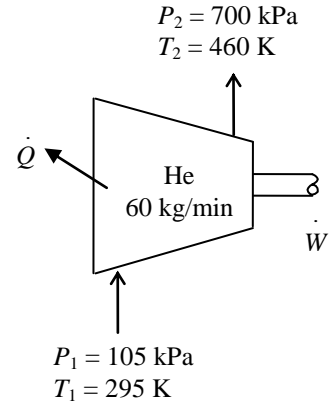

5-51 CO₂ is compressed by a compressor. The volume flow rate of CO₂ at the compressor inlet and the power input to the compressor are to be determined.

Assumptions 1 This is a steady-flow process since there is no change with time. **2** Kinetic and potential energy changes are negligible. **3** Helium is an ideal gas with variable specific heats. **4** The device is adiabatic and thus heat transfer is negligible.

Properties The gas constant of CO₂ is $R = 0.1889 \text{ kPa}\cdot\text{m}^3/\text{kg}\cdot\text{K}$, and its molar mass is $M = 44 \text{ kg/kmol}$ (Table A-1). The inlet and exit enthalpies of CO₂ are (Table A-20)

$$T_1 = 300 \text{ K} \rightarrow \bar{h}_1 = 9,431 \text{ kJ/kmol}$$

$$T_2 = 450 \text{ K} \rightarrow \bar{h}_2 = 15,483 \text{ kJ/kmol}$$

Analysis (a) There is only one inlet and one exit, and thus $\dot{m}_1 = \dot{m}_2 = \dot{m}$. The inlet specific volume of air and its volume flow rate are

$$\nu_1 = \frac{RT_1}{P_1} = \frac{(0.1889 \text{ kPa}\cdot\text{m}^3/\text{kg}\cdot\text{K})(300 \text{ K})}{100 \text{ kPa}} = 0.5667 \text{ m}^3/\text{kg}$$

$$\dot{V} = \dot{m}\nu_1 = (0.5 \text{ kg/s})(0.5667 \text{ m}^3/\text{kg}) = \mathbf{0.283 \text{ m}^3/\text{s}}$$

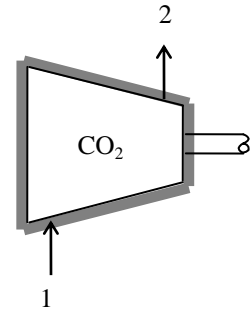

(b) We take the compressor as the system, which is a control volume since mass crosses the boundary. The energy balance for this steady-flow system can be expressed in the rate form as

$$\underbrace{\dot{E}_{\text{in}} - \dot{E}_{\text{out}}}_{\text{Rate of net energy transfer by heat, work, and mass}} = \underbrace{\dot{\Delta E}_{\text{system}}}_{\text{Rate of change in internal, kinetic, potential, etc. energies}} \stackrel{\text{no (steady)}}{=} 0$$

$$\dot{E}_{\text{in}} = \dot{E}_{\text{out}}$$

$$\dot{W}_{\text{in}} + \dot{m}h_1 = \dot{m}h_2 \quad (\text{since } \dot{Q} \cong \Delta \text{ke} \cong \Delta \text{pe} \cong 0)$$

$$\dot{W}_{\text{in}} = \dot{m}(h_2 - h_1) = \dot{m}(\bar{h}_2 - \bar{h}_1) / M$$

Substituting

$$\dot{W}_{\text{in}} = \frac{(0.5 \text{ kg/s})(15,483 - 9,431 \text{ kJ/kmol})}{44 \text{ kg/kmol}} = \mathbf{68.8 \text{ kW}}$$

5-52E Air is compressed by a compressor. The mass flow rate of air through the compressor and the exit temperature of air are to be determined.

Assumptions 1 This is a steady-flow process since there is no change with time. **2** Kinetic and potential energy changes are negligible. **3** Air is an ideal gas with variable specific heats.

Properties The gas constant of air is $R = 0.3704 \text{ psia}\cdot\text{ft}^3/\text{lbm}\cdot\text{R}$ (Table A-1E). The inlet enthalpy of air is (Table A-17E)

$$T_1 = 60^\circ\text{F} = 520 \text{ R} \quad \rightarrow \quad h_1 = h_{@ 520 \text{ R}} = 124.27 \text{ Btu/lbm}$$

Analysis (a) There is only one inlet and one exit, and thus $\dot{m}_1 = \dot{m}_2 = \dot{m}$. The inlet specific volume of air and its mass flow rate are

$$v_1 = \frac{RT_1}{P_1} = \frac{(0.3704 \text{ psia}\cdot\text{ft}^3/\text{lbm}\cdot\text{R})(520 \text{ R})}{14.7 \text{ psia}} = 13.1 \text{ ft}^3/\text{lbm}$$

$$\dot{m} = \frac{\dot{V}_1}{v_1} = \frac{5000 \text{ ft}^3/\text{min}}{13.1 \text{ ft}^3/\text{lbm}} = 381.7 \text{ lbm}/\text{min} = \mathbf{6.36 \text{ lbm/s}}$$

(b) We take the compressor as the system, which is a control volume since mass crosses the boundary. The energy balance for this steady-flow system can be expressed in the rate form as

$$\underbrace{\dot{E}_{\text{in}} - \dot{E}_{\text{out}}}_{\text{Rate of net energy transfer by heat, work, and mass}} = \underbrace{\Delta\dot{E}_{\text{system}}}_{\text{Rate of change in internal, kinetic, potential, etc. energies}} \stackrel{\text{no (steady)}}{=} 0$$

$$\dot{E}_{\text{in}} = \dot{E}_{\text{out}}$$

$$\dot{W}_{\text{in}} + \dot{m}h_1 = \dot{Q}_{\text{out}} + \dot{m}h_2 \quad (\text{since } \Delta\text{ke} \cong \Delta\text{pe} \cong 0)$$

$$\dot{W}_{\text{in}} - \dot{Q}_{\text{out}} = \dot{m}(h_2 - h_1)$$

Substituting,

$$(700 \text{ hp}) \left(\frac{0.7068 \text{ Btu/s}}{1 \text{ hp}} \right) - (6.36 \text{ lbm/s}) \times (10 \text{ Btu/lbm}) = (6.36 \text{ lbm/s})(h_2 - 124.27 \text{ Btu/lbm})$$

$$h_2 = 192.06 \text{ Btu/lbm}$$

Then the exit temperature is determined from Table A-17E to be

$$T_2 = 801 \text{ R} = \mathbf{341^\circ\text{F}}$$

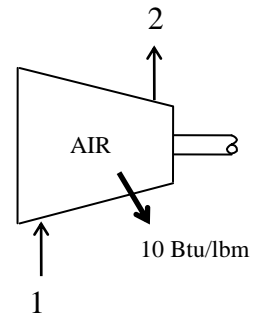



5-53E Problem 5-52E is reconsidered. The effect of the rate of cooling of the compressor on the exit temperature of air as the cooling rate varies from 0 to 100 Btu/lbm is to be investigated. The air exit temperature is to be plotted against the rate of cooling.

Analysis The problem is solved using EES, and the solution is given below.

"Knowns "

T[1] = 60 [F]
 P[1] = 14.7 [psia]
 V_dot[1] = 5000 [ft^3/min]
 P[2] = 150 [psia]
 {q_out=10 [Btu/lbm]}
 W_dot_in=700 [hp]

"Property Data"

h[1]=enthalpy(Air,T=T[1])
 h[2]=enthalpy(Air,T=T[2])
 TR_2=T[2]+460 "[R]"
 v[1]=volume(Air,T=T[1],p=P[1])
 v[2]=volume(Air,T=T[2],p=P[2])

"Conservation of mass: "

m_dot[1]= m_dot[2]

"Mass flow rate"

m_dot[1]=V_dot[1]/v[1] *convert(ft^3/min,ft^3/s)
 m_dot[2]= V_dot[2]/v[2]*convert(ft^3/min,ft^3/s)

"Conservation of Energy - Steady Flow energy balance"

W_dot_in*convert(hp,Btu/s)+m_dot[1]*(h[1]) = m_dot[1]*q_out+m_dot[1]*(h[2])

q _{out} [Btu/lbm]	T ₂ [F]
0	382
10	340.9
20	299.7
30	258.3
40	216.9
50	175.4
60	133.8
70	92.26
80	50.67
90	9.053
100	-32.63

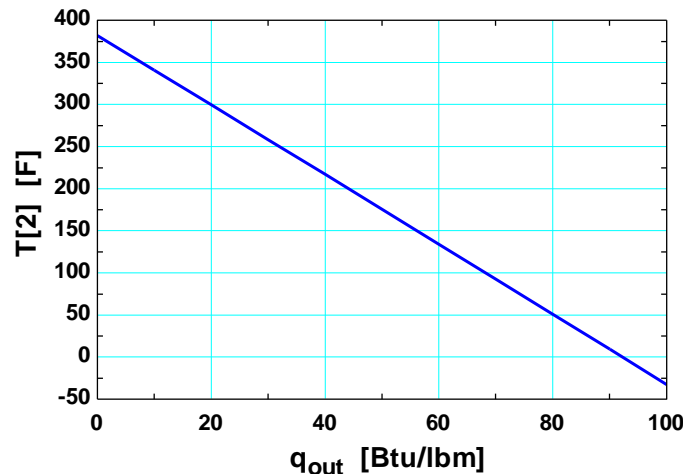

5-54 Air is expanded in an adiabatic turbine. The mass flow rate of the air and the power produced are to be determined.

Assumptions 1 This is a steady-flow process since there is no change with time. **2** The turbine is well-insulated, and thus there is no heat transfer. **3** Air is an ideal gas with constant specific heats.

Properties The constant pressure specific heat of air at the average temperature of $(500+127)/2=314^\circ\text{C}=587\text{ K}$ is $c_p = 1.048\text{ kJ/kg}\cdot\text{K}$ (Table A-2b). The gas constant of air is $R = 0.287\text{ kPa}\cdot\text{m}^3/\text{kg}\cdot\text{K}$ (Table A-1).

Analysis (a) There is only one inlet and one exit, and thus $\dot{m}_1 = \dot{m}_2 = \dot{m}$. We take the turbine as the system, which is a control volume since mass crosses the boundary. The energy balance for this steady-flow system can be expressed in the rate form as

$$\underbrace{\dot{E}_{\text{in}} - \dot{E}_{\text{out}}}_{\substack{\text{Rate of net energy transfer} \\ \text{by heat, work, and mass}}} = \underbrace{\Delta \dot{E}_{\text{system}}}_{\substack{\text{Rate of change in internal, kinetic,} \\ \text{potential, etc. energies}}} \stackrel{\text{no (steady)}}{=} 0$$

$$\dot{E}_{\text{in}} = \dot{E}_{\text{out}}$$

$$\dot{m} \left(h_1 + \frac{V_1^2}{2} \right) = \dot{m} \left(h_2 + \frac{V_2^2}{2} \right) + \dot{W}_{\text{out}}$$

$$\dot{W}_{\text{out}} = \dot{m} \left(h_1 - h_2 + \frac{V_1^2 - V_2^2}{2} \right) = \dot{m} \left(c_p (T_1 - T_2) + \frac{V_1^2 - V_2^2}{2} \right)$$

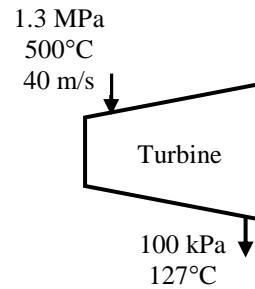

The specific volume of air at the inlet and the mass flow rate are

$$\nu_1 = \frac{RT_1}{P_1} = \frac{(0.287\text{ kPa}\cdot\text{m}^3/\text{kg}\cdot\text{K})(500 + 273\text{ K})}{1300\text{ kPa}} = 0.1707\text{ m}^3/\text{kg}$$

$$\dot{m} = \frac{A_1 V_1}{\nu_1} = \frac{(0.2\text{ m}^2)(40\text{ m/s})}{0.1707\text{ m}^3/\text{kg}} = \mathbf{46.88\text{ kg/s}}$$

Similarly at the outlet,

$$\nu_2 = \frac{RT_2}{P_2} = \frac{(0.287\text{ kPa}\cdot\text{m}^3/\text{kg}\cdot\text{K})(127 + 273\text{ K})}{100\text{ kPa}} = 1.148\text{ m}^3/\text{kg}$$

$$V_2 = \frac{\dot{m}\nu_2}{A_2} = \frac{(46.88\text{ kg/s})(1.148\text{ m}^3/\text{kg})}{1\text{ m}^2} = 53.82\text{ m/s}$$

(b) Substituting into the energy balance equation gives

$$\begin{aligned} \dot{W}_{\text{out}} &= \dot{m} \left(c_p (T_1 - T_2) + \frac{V_1^2 - V_2^2}{2} \right) \\ &= (46.88\text{ kg/s}) \left[(1.048\text{ kJ/kg}\cdot\text{K})(500 - 127)\text{K} + \frac{(40\text{ m/s})^2 - (53.82\text{ m/s})^2}{2} \left(\frac{1\text{ kJ/kg}}{1000\text{ m}^2/\text{s}^2} \right) \right] \\ &= \mathbf{18,300\text{ kW}} \end{aligned}$$

5-55 Steam expands in a two-stage adiabatic turbine from a specified state to another state. Some steam is extracted at the end of the first stage. The power output of the turbine is to be determined.

Assumptions 1 This is a steady-flow process since there is no change with time. **2** Kinetic and potential energy changes are negligible. **3** The turbine is adiabatic and thus heat transfer is negligible.

Properties From the steam tables (Tables A-5 and A-6)

$$\left. \begin{array}{l} P_1 = 8 \text{ MPa} \\ T_1 = 600^\circ\text{C} \end{array} \right\} h_1 = 3642.4 \text{ kJ/kg}$$

$$\left. \begin{array}{l} P_2 = 0.3 \text{ MPa} \\ x_2 = 1 \end{array} \right\} h_2 = 2724.9 \text{ kJ/kg}$$

$$\left. \begin{array}{l} P_3 = 10 \text{ kPa} \\ x_3 = 0.85 \end{array} \right\} h_3 = h_f + xh_{fg} \\ = 191.81 + (0.85)(2392.1) = 2225.1 \text{ kJ/kg}$$

Analysis We take the entire turbine, including the connection part between the two stages, as the system, which is a control volume since mass crosses the boundary. Noting that one fluid stream enters the turbine and two fluid streams leave, the energy balance for this steady-flow system can be expressed in the rate form as

$$\underbrace{\dot{E}_{\text{in}} - \dot{E}_{\text{out}}}_{\text{Rate of net energy transfer by heat, work, and mass}} = \underbrace{\Delta \dot{E}_{\text{system}}^{\neq 0} (\text{steady})}_{\text{Rate of change in internal, kinetic, potential, etc. energies}} = 0$$

$$\dot{E}_{\text{in}} = \dot{E}_{\text{out}}$$

$$\dot{m}_1 h_1 = \dot{m}_2 h_2 + \dot{m}_3 h_3 + \dot{W}_{\text{out}}$$

$$\dot{W}_{\text{out}} = \dot{m}_1 (h_1 - 0.1h_2 - 0.9h_3)$$

Substituting, the power output of the turbine is

$$\begin{aligned} \dot{W}_{\text{out}} &= \dot{m}_1 (h_1 - 0.1h_2 - 0.9h_3) \\ &= (13 \text{ kg/s})(3642.4 - 0.1 \times 2724.9 - 0.9 \times 2225.1) \text{ kJ/kg} \\ &= 17,776 \text{ kW} = \mathbf{17.8 \text{ MW}} \end{aligned}$$

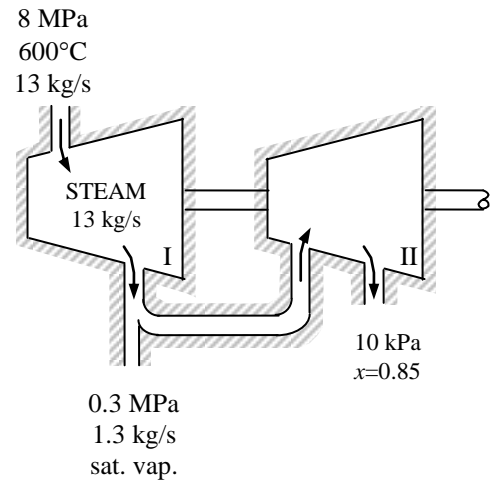

5-56 Steam is expanded in a turbine. The power output is given. The rate of heat transfer is to be determined.

Assumptions 1 This is a steady-flow process since there is no change with time. **2** Kinetic and potential energy changes are negligible.

Properties From the steam tables (Table A-4, A5, A-6)

$$\left. \begin{array}{l} P_1 = 6 \text{ MPa} \\ T_1 = 600^\circ\text{C} \end{array} \right\} h_1 = 3658.8 \text{ kJ/kg}$$

$$\left. \begin{array}{l} P_2 = 0.5 \text{ MPa} \\ T_2 = 200^\circ\text{C} \end{array} \right\} h_2 = 2855.8 \text{ kJ/kg}$$

Analysis We take the turbine as the system, which is a control volume since mass crosses the boundary. Noting that one fluid stream enters and leaves the compressor, the energy balance for this steady-flow system can be expressed in the rate form as

$$\underbrace{\dot{E}_{\text{in}} - \dot{E}_{\text{out}}}_{\text{Rate of net energy transfer by heat, work, and mass}} = \underbrace{\Delta \dot{E}_{\text{system}}^{\phi^0} (\text{steady})}_{\text{Rate of change in internal, kinetic, potential, etc. energies}} = 0$$

$$\dot{E}_{\text{in}} = \dot{E}_{\text{out}}$$

$$\dot{m} \left(h_1 + \frac{V_1^2}{2} \right) = \dot{m} \left(h_2 + \frac{V_2^2}{2} \right) + \dot{W}_{\text{out}} + \dot{Q}_{\text{out}} \quad (\text{since } \Delta pe \cong 0)$$

$$\dot{Q}_{\text{out}} = -\dot{W}_{\text{out}} + \dot{m} \left(h_1 - h_2 + \frac{V_1^2 - V_2^2}{2} \right)$$

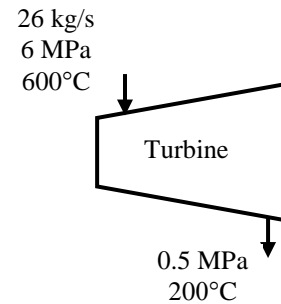

Substituting,

$$\begin{aligned} \dot{Q}_{\text{out}} &= -\dot{W}_{\text{out}} + \dot{m} \left(h_1 - h_2 + \frac{V_1^2 - V_2^2}{2} \right) \\ &= 20,000 \text{ kW} + (26 \text{ kg/s}) \left[(3658.8 - 2855.8) \text{ kJ/kg} + \frac{(0 - 180 \text{ m/s})^2}{2} \left(\frac{1 \text{ kJ/kg}}{1000 \text{ m}^2/\text{s}^2} \right) \right] \\ &= \mathbf{455 \text{ kW}} \end{aligned}$$

5-57 Air is compressed by a compressor. The mass flow rate of air through the compressor is to be determined.

Assumptions **1** This is a steady-flow process since there is no change with time. **2** Potential energy changes are negligible. **3** Air is an ideal gas with variable specific heats.

Properties The inlet and exit enthalpies of air are (Table A-17)

$$T_1 = 25^\circ\text{C} = 298 \text{ K} \quad \rightarrow \quad h_1 = h_{@ 298 \text{ K}} = 298.2 \text{ kJ/kg}$$

$$T_2 = 347^\circ\text{C} = 620 \text{ K} \quad \rightarrow \quad h_2 = h_{@ 620 \text{ K}} = 628.07 \text{ kJ/kg}$$

Analysis We take the compressor as the system, which is a control volume since mass crosses the boundary. The energy balance for this steady-flow system can be expressed in the rate form as

$$\underbrace{\dot{E}_{\text{in}} - \dot{E}_{\text{out}}}_{\text{Rate of net energy transfer by heat, work, and mass}} = \underbrace{\Delta \dot{E}_{\text{system}}}_{\text{Rate of change in internal, kinetic, potential, etc. energies}} \stackrel{\text{no (steady)}}{=} 0$$

$$\dot{E}_{\text{in}} = \dot{E}_{\text{out}}$$

$$\dot{W}_{\text{in}} + \dot{m}(h_1 + V_1^2/2) = \dot{Q}_{\text{out}} + \dot{m}(h_2 + V_2^2/2) \quad (\text{since } \Delta p_e \cong 0)$$

$$\dot{W}_{\text{in}} - \dot{Q}_{\text{out}} = \dot{m} \left(h_2 - h_1 + \frac{V_2^2 - V_1^2}{2} \right)$$

Substituting, the mass flow rate is determined to be

$$250 \text{ kJ/s} - (1500/60 \text{ kJ/s}) = \dot{m} \left[628.07 - 298.2 + \frac{(90 \text{ m/s})^2 - 0}{2} \left(\frac{1 \text{ kJ/kg}}{1000 \text{ m}^2/\text{s}^2} \right) \right] \rightarrow \dot{m} = \mathbf{0.674 \text{ kg/s}}$$

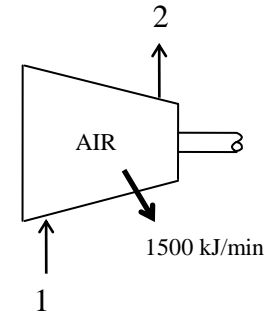

Throttling Valves

5-58C Because usually there is a large temperature drop associated with the throttling process.

5-59C No. Because air is an ideal gas and $h = h(T)$ for ideal gases. Thus if h remains constant, so does the temperature.

5-60C If it remains in the liquid phase, no. But if some of the liquid vaporizes during throttling, then yes.

5-61C Yes.

5-62 Refrigerant-134a is throttled by a valve. The temperature drop of the refrigerant and the specific volume after expansion are to be determined.

Assumptions 1 This is a steady-flow process since there is no change with time. **2** Kinetic and potential energy changes are negligible. **3** Heat transfer to or from the fluid is negligible. **4** There are no work interactions involved.

Properties The inlet enthalpy of R-134a is, from the refrigerant tables (Tables A-11 through 13),

$$\left. \begin{array}{l} P_1 = 0.7 \text{ MPa} \\ \text{sat. liquid} \end{array} \right\} \begin{array}{l} T_1 = T_{\text{sat}} = 26.69^\circ\text{C} \\ h_1 = h_f = 88.82 \text{ kJ/kg} \end{array}$$

$$\left. \begin{array}{l} P_1 = 700 \text{ kPa} \\ \text{Sat. liquid} \end{array} \right\}$$

Analysis There is only one inlet and one exit, and thus $\dot{m}_1 = \dot{m}_2 = \dot{m}$.

We take the throttling valve as the system, which is a control volume since mass crosses the boundary. The energy balance for this steady-flow system can be expressed in the rate form as

$$\dot{E}_{\text{in}} - \dot{E}_{\text{out}} = \Delta \dot{E}_{\text{system}} \stackrel{\text{no (steady)}}{=} 0 \rightarrow \dot{E}_{\text{in}} = \dot{E}_{\text{out}} \rightarrow \dot{m}h_1 = \dot{m}h_2 \rightarrow h_1 = h_2$$

since $\dot{Q} \cong \dot{W} = \Delta ke \cong \Delta pe \cong 0$. Then,

$$\left. \begin{array}{l} P_2 = 160 \text{ kPa} \\ (h_2 = h_1) \end{array} \right\} \begin{array}{l} h_f = 31.18 \text{ kJ/kg}, \quad T_{\text{sat}} = -15.60^\circ\text{C} \\ h_g = 241.14 \text{ kJ/kg} \end{array}$$

Obviously $h_f < h_2 < h_g$, thus the refrigerant exists as a saturated mixture at the exit state and thus $T_2 = T_{\text{sat}} = -15.60^\circ\text{C}$. Then the temperature drop becomes

$$\Delta T = T_2 - T_1 = -15.60 - 26.69 = \mathbf{-42.3^\circ\text{C}}$$

The quality at this state is determined from

$$x_2 = \frac{h_2 - h_f}{h_{fg}} = \frac{88.82 - 31.18}{209.96} = 0.2745$$

Thus,

$$\nu_2 = \nu_f + x_2 \nu_{fg} = 0.0007435 + 0.2745 \times (0.12355 - 0.0007435) = \mathbf{0.0345 \text{ m}^3/\text{kg}}$$

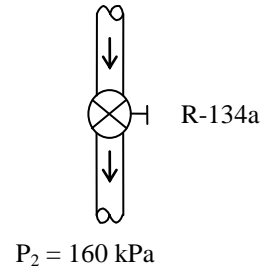

5-63 Steam is throttled from a specified pressure to a specified state. The quality at the inlet is to be determined.

Assumptions 1 This is a steady-flow process since there is no change with time. **2** Kinetic and potential energy changes are negligible. **3** Heat transfer to or from the fluid is negligible. **4** There are no work interactions involved.

Analysis There is only one inlet and one exit, and thus $\dot{m}_1 = \dot{m}_2 = \dot{m}$. We take the throttling valve as the system, which is a control volume since mass crosses the boundary. The energy balance for this steady-flow system can be expressed in the rate form as

$$\begin{aligned}\dot{E}_{\text{in}} - \dot{E}_{\text{out}} &= \Delta \dot{E}_{\text{system}} \stackrel{\text{no (steady)}}{=} 0 \\ \dot{E}_{\text{in}} &= \dot{E}_{\text{out}} \\ \dot{m}h_1 &= \dot{m}h_2 \\ h_1 &= h_2\end{aligned}$$

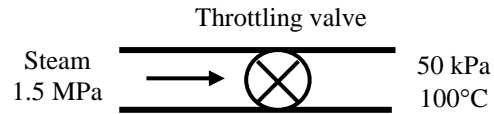

since $\dot{Q} \cong \dot{W} = \Delta \text{ke} \cong \Delta \text{pe} \cong 0$.

The enthalpy of steam at the exit is (Table A-6),

$$\left. \begin{array}{l} P_2 = 50 \text{ kPa} \\ T_2 = 100^\circ\text{C} \end{array} \right\} h_2 = 2682.4 \text{ kJ/kg}$$

The quality of the steam at the inlet is (Table A-5)

$$\left. \begin{array}{l} P_1 = 1500 \text{ kPa} \\ h_1 = h_2 = 2682.4 \text{ kJ/kg} \end{array} \right\} x_1 = \frac{h_2 - h_f}{h_{fg}} = \frac{2682.4 - 844.55}{1946.4} = \mathbf{0.944}$$

5-64  Refrigerant-134a is throttled by a valve. The pressure and internal energy after expansion are to be determined.

Assumptions 1 This is a steady-flow process since there is no change with time. **2** Kinetic and potential energy changes are negligible. **3** Heat transfer to or from the fluid is negligible. **4** There are no work interactions involved.

Properties The inlet enthalpy of R-134a is, from the refrigerant tables (Tables A-11 through 13),

$$\left. \begin{array}{l} P_1 = 0.8 \text{ MPa} \\ T_1 = 25^\circ\text{C} \end{array} \right\} h_1 \cong h_{f@25^\circ\text{C}} = 86.41 \text{ kJ/kg}$$

Analysis There is only one inlet and one exit, and thus $\dot{m}_1 = \dot{m}_2 = \dot{m}$. We take the throttling valve as the system, which is a control volume since mass crosses the boundary. The energy balance for this steady-flow system can be expressed in the rate form as

$$\dot{E}_{\text{in}} - \dot{E}_{\text{out}} = \Delta \dot{E}_{\text{system}} \stackrel{\text{no (steady)}}{=} 0$$

$$\dot{E}_{\text{in}} = \dot{E}_{\text{out}}$$

$$\dot{m}h_1 = \dot{m}h_2$$

$$h_1 = h_2$$

since $\dot{Q} \cong \dot{W} = \Delta ke \cong \Delta pe \cong 0$. Then,

$$\left. \begin{array}{l} T_2 = -20^\circ\text{C} \\ (h_2 = h_1) \end{array} \right\} \begin{array}{l} h_f = 25.47 \text{ kJ/kg}, \quad u_f = 25.37 \text{ kJ/kg} \\ h_g = 238.43 \text{ kJ/kg}, \quad u_g = 218.86 \text{ kJ/kg} \end{array}$$

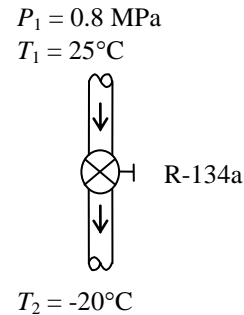

Obviously $h_f < h_2 < h_g$, thus the refrigerant exists as a saturated mixture at the exit state, and thus

$$P_2 = P_{\text{sat @ } -20^\circ\text{C}} = \mathbf{132.82 \text{ kPa}}$$

Also,

$$x_2 = \frac{h_2 - h_f}{h_{fg}} = \frac{86.41 - 25.47}{212.96} = 0.2862$$

Thus,

$$u_2 = u_f + x_2 u_{fg} = 25.37 + 0.2862 \times 193.49 = \mathbf{80.7 \text{ kJ/kg}}$$

5-65 Steam is throttled by a well-insulated valve. The temperature drop of the steam after the expansion is to be determined.

Assumptions **1** This is a steady-flow process since there is no change with time. **2** Kinetic and potential energy changes are negligible. **3** Heat transfer to or from the fluid is negligible. **4** There are no work interactions involved.

Properties The inlet enthalpy of steam is (Tables A-6),

$$\left. \begin{array}{l} P_1 = 8 \text{ MPa} \\ T_1 = 350^\circ\text{C} \end{array} \right\} h_1 = 2988.1 \text{ kJ/kg}$$

Analysis There is only one inlet and one exit, and thus $\dot{m}_1 = \dot{m}_2 = \dot{m}$. We take the throttling valve as the system, which is a control volume since mass crosses the boundary. The energy balance for this steady-flow system can be expressed in the rate form as

$$\begin{aligned} \dot{E}_{\text{in}} - \dot{E}_{\text{out}} &= \Delta \dot{E}_{\text{system}} \stackrel{\text{no (steady)}}{=} 0 \\ \dot{E}_{\text{in}} &= \dot{E}_{\text{out}} \\ \dot{m}h_1 &= \dot{m}h_2 \\ h_1 &= h_2 \end{aligned}$$

since $\dot{Q} \cong \dot{W} = \Delta ke \cong \Delta pe \cong 0$. Then the exit temperature of steam becomes

$$\left. \begin{array}{l} P_2 = 2 \text{ MPa} \\ (h_2 = h_1) \end{array} \right\} T_2 = 285^\circ\text{C}$$

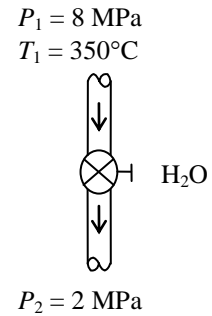



5-66 Problem 5-65 is reconsidered. The effect of the exit pressure of steam on the exit temperature after throttling as the exit pressure varies from 6 MPa to 1 MPa is to be investigated. The exit temperature of steam is to be plotted against the exit pressure.

Analysis The problem is solved using EES, and the solution is given below.

```
WorkingFluid$='Steam_iapws' "WorkingFluid can be changed to ammonia or other fluids"
P_in=8000 [kPa]
T_in=350 [C]
P_out=2000 [kPa]
```

"Analysis"

```
m_dot_in=m_dot_out "steady-state mass balance"
m_dot_in=1 "mass flow rate is arbitrary"
m_dot_in*h_in+Q_dot-W_dot-m_dot_out*h_out=0 "steady-state energy balance"
Q_dot=0 "assume the throttle to operate adiabatically"
W_dot=0 "throttles do not have any means of producing power"
h_in=enthalpy(WorkingFluid$,T=T_in,P=P_in) "property table lookup"
T_out=temperature(WorkingFluid$,P=P_out,h=h_out) "property table lookup"
x_out=quality(WorkingFluid$,P=P_out,h=h_out) "x_out is the quality at the outlet"
P[1]=P_in; P[2]=P_out; h[1]=h_in; h[2]=h_out "use arrays to place points on property plot"
```

P _{out} [kPa]	T _{out} [C]
1000	270.5
1500	277.7
2000	284.6
2500	291.2
3000	297.6
3500	303.7
4000	309.5
4500	315.2
5000	320.7
5500	325.9
6000	331

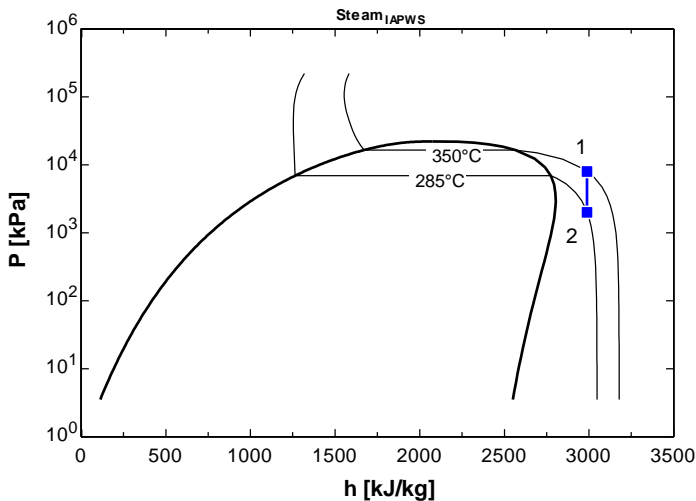
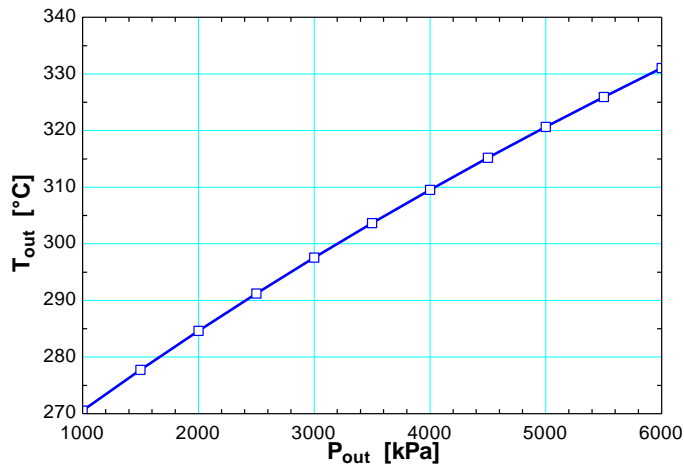

5-67E Refrigerant-134a is throttled by a valve. The temperature and internal energy change are to be determined.

Assumptions 1 This is a steady-flow process since there is no change with time. **2** Kinetic and potential energy changes are negligible. **3** Heat transfer to or from the fluid is negligible. **4** There are no work interactions involved.

Analysis There is only one inlet and one exit, and thus $\dot{m}_1 = \dot{m}_2 = \dot{m}$. We take the throttling valve as the system, which is a control volume since mass crosses the boundary. The energy balance for this steady-flow system can be expressed in the rate form as

$$\begin{aligned}\dot{E}_{\text{in}} - \dot{E}_{\text{out}} &= \Delta \dot{E}_{\text{system}} \stackrel{\text{no (steady)}}{=} 0 \\ \dot{E}_{\text{in}} &= \dot{E}_{\text{out}} \\ \dot{m}h_1 &= \dot{m}h_2 \\ h_1 &= h_2\end{aligned}$$

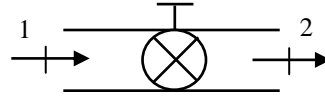

since $\dot{Q} \cong \dot{W} = \Delta ke \cong \Delta pe \cong 0$. The properties are (Tables A-11E through 13E),

$$P_1 = 120 \text{ psia} \left. \begin{array}{l} h_1 = 41.79 \text{ Btu/lbm} \\ u_1 = 41.49 \text{ Btu/lbm} \\ x_1 = 0 \end{array} \right\} T_1 = 90.49^\circ\text{F}$$

$$P_2 = 20 \text{ psia} \left. \begin{array}{l} T_2 = -2.43^\circ\text{F} \\ u_2 = 38.96 \text{ Btu/lbm} \end{array} \right\} h_2 = h_1 = 41.79 \text{ Btu/lbm}$$

$$\Delta T = T_2 - T_1 = -2.43 - 90.49 = \mathbf{-92.9^\circ\text{F}}$$

$$\Delta u = u_2 - u_1 = 38.96 - 41.49 = \mathbf{-2.53 \text{ Btu/lbm}}$$

That is, the temperature drops by 92.9°F and internal energy drops by 2.53 Btu/lbm.

Mixing Chambers and Heat Exchangers

5-68C Under the conditions of no heat and work interactions between the mixing chamber and the surrounding medium.

5-69C Under the conditions of no heat and work interactions between the heat exchanger and the surrounding medium.

5-70C Yes, if the mixing chamber is losing heat to the surrounding medium.

5-71 Liquid water is heated in a chamber by mixing it with superheated steam. For a specified mixing temperature, the mass flow rate of the steam is to be determined.

Assumptions 1 This is a steady-flow process since there is no change with time. **2** Kinetic and potential energy changes are negligible. **3** There are no work interactions. **4** The device is adiabatic and thus heat transfer is negligible.

Properties Noting that $T < T_{\text{sat @ 300 kPa}} = 133.52^\circ\text{C}$, the cold water stream and the mixture exist as a compressed liquid, which can be approximated as a saturated liquid at the given temperature. Thus, from steam tables (Tables A-4 through A-6)

$$h_1 \cong h_f @ 20^\circ\text{C} = 83.91 \text{ kJ/kg}$$

$$h_3 \cong h_f @ 60^\circ\text{C} = 251.18 \text{ kJ/kg}$$

and

$$\left. \begin{array}{l} P_2 = 300 \text{ kPa} \\ T_2 = 300^\circ\text{C} \end{array} \right\} h_2 = 3069.6 \text{ kJ/kg}$$

Analysis We take the mixing chamber as the system, which is a control volume since mass crosses the boundary. The mass and energy balances for this steady-flow system can be expressed in the rate form as

$$\text{Mass balance:} \quad \dot{m}_{\text{in}} - \dot{m}_{\text{out}} = \Delta \dot{m}_{\text{system}} \stackrel{\approx 0 \text{ (steady)}}{=} 0 \rightarrow \dot{m}_{\text{in}} = \dot{m}_{\text{out}} \rightarrow \dot{m}_1 + \dot{m}_2 = \dot{m}_3$$

Energy balance:

$$\underbrace{\dot{E}_{\text{in}} - \dot{E}_{\text{out}}}_{\text{Rate of net energy transfer by heat, work, and mass}} = \underbrace{\Delta \dot{E}_{\text{system}}}_{\text{Rate of change in internal, kinetic, potential, etc. energies}} \stackrel{\approx 0 \text{ (steady)}}{=} 0$$

$$\dot{E}_{\text{in}} = \dot{E}_{\text{out}}$$

$$\dot{m}_1 h_1 + \dot{m}_2 h_2 = \dot{m}_3 h_3 \quad (\text{since } \dot{Q} = \dot{W} = \Delta \text{ke} \cong \Delta \text{pe} \cong 0)$$

Combining the two,

$$\dot{m}_1 h_1 + \dot{m}_2 h_2 = (\dot{m}_1 + \dot{m}_2) h_3$$

Solving for \dot{m}_2 :

$$\dot{m}_2 = \frac{h_1 - h_3}{h_3 - h_2} \dot{m}_1$$

Substituting,

$$\dot{m}_2 = \frac{(83.91 - 251.18) \text{ kJ/kg}}{(251.18 - 3069.6) \text{ kJ/kg}} (1.8 \text{ kg/s}) = \mathbf{0.107 \text{ kg/s}}$$

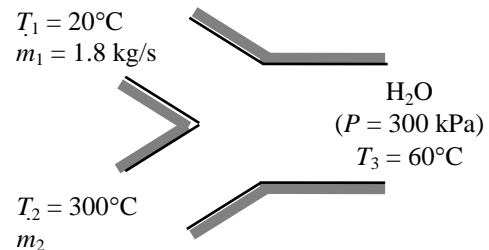

5-72 Feedwater is heated in a chamber by mixing it with superheated steam. If the mixture is saturated liquid, the ratio of the mass flow rates of the feedwater and the superheated vapor is to be determined.

Assumptions 1 This is a steady-flow process since there is no change with time. **2** Kinetic and potential energy changes are negligible. **3** There are no work interactions. **4** The device is adiabatic and thus heat transfer is negligible.

Properties Noting that $T < T_{\text{sat}@ 1 \text{ MPa}} = 179.88^\circ\text{C}$, the cold water stream and the mixture exist as a compressed liquid, which can be approximated as a saturated liquid at the given temperature. Thus, from steam tables (Tables A-4 through A-6)

$$h_1 \cong h_f @ 50^\circ\text{C} = 209.34 \text{ kJ/kg}$$

$$h_3 \cong h_f @ 1 \text{ MPa} = 762.51 \text{ kJ/kg}$$

and

$$\left. \begin{array}{l} P_2 = 1 \text{ MPa} \\ T_2 = 200^\circ\text{C} \end{array} \right\} h_2 = 2828.3 \text{ kJ/kg}$$

Analysis We take the mixing chamber as the system, which is a control volume since mass crosses the boundary. The mass and energy balances for this steady-flow system can be expressed in the rate form as

$$\text{Mass balance:} \quad \dot{m}_{\text{in}} - \dot{m}_{\text{out}} = \Delta \dot{m}_{\text{system}} \stackrel{\approx 0 \text{ (steady)}}{=} 0 \rightarrow \dot{m}_{\text{in}} = \dot{m}_{\text{out}} \rightarrow \dot{m}_1 + \dot{m}_2 = \dot{m}_3$$

Energy balance:

$$\underbrace{\dot{E}_{\text{in}} - \dot{E}_{\text{out}}}_{\text{Rate of net energy transfer by heat, work, and mass}} = \underbrace{\Delta \dot{E}_{\text{system}} \stackrel{\approx 0 \text{ (steady)}}{=}}_{\text{Rate of change in internal, kinetic, potential, etc. energies}} = 0$$

$$\dot{E}_{\text{in}} = \dot{E}_{\text{out}}$$

$$\dot{m}_1 h_1 + \dot{m}_2 h_2 = \dot{m}_3 h_3 \quad (\text{since } \dot{Q} = \dot{W} = \Delta \text{ke} \cong \Delta \text{pe} \cong 0)$$

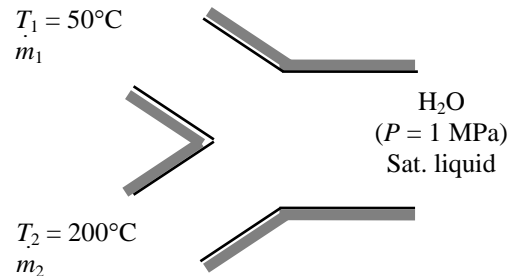

Combining the two,

$$\dot{m}_1 h_1 + \dot{m}_2 h_2 = (\dot{m}_1 + \dot{m}_2) h_3$$

Dividing by \dot{m}_2 yields

$$y h_1 + h_2 = (y + 1) h_3$$

Solving for y :

$$y = \frac{h_3 - h_2}{h_1 - h_3}$$

where $y = \dot{m}_1 / \dot{m}_2$ is the desired mass flow rate ratio. Substituting,

$$y = \frac{762.51 - 2828.3}{209.34 - 762.51} = \mathbf{3.73}$$

5-73E Liquid water is heated in a chamber by mixing it with saturated water vapor. If both streams enter at the same rate, the temperature and quality (if saturated) of the exit stream is to be determined.

Assumptions 1 This is a steady-flow process since there is no change with time. **2** Kinetic and potential energy changes are negligible. **3** There are no work interactions. **4** The device is adiabatic and thus heat transfer is negligible.

Properties From steam tables (Tables A-5E through A-6E),

$$h_1 \cong h_f @ 65^\circ\text{F} = 33.08 \text{ Btu/lbm}$$

$$h_2 = h_g @ 20 \text{ psia} = 1156.2 \text{ Btu/lbm}$$

Analysis We take the mixing chamber as the system, which is a control volume since mass crosses the boundary. The mass and energy balances for this steady-flow system can be expressed in the rate form as

Mass balance:

$$\dot{m}_{\text{in}} - \dot{m}_{\text{out}} = \Delta \dot{m}_{\text{system}} \stackrel{\approx 0 \text{ (steady)}}{=} 0$$

$$\dot{m}_{\text{in}} = \dot{m}_{\text{out}}$$

$$\dot{m}_1 + \dot{m}_2 = \dot{m}_3 = 2\dot{m}$$

$$\dot{m}_1 = \dot{m}_2 = \dot{m}$$

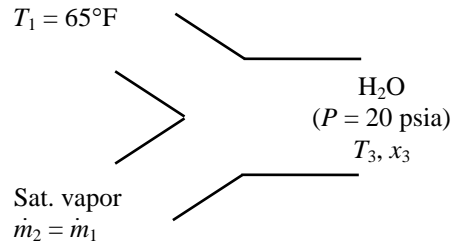

Energy balance:

$$\underbrace{\dot{E}_{\text{in}} - \dot{E}_{\text{out}}}_{\text{Rate of net energy transfer by heat, work, and mass}} = \underbrace{\Delta \dot{E}_{\text{system}} \stackrel{\approx 0 \text{ (steady)}}{=}}_{\text{Rate of change in internal, kinetic, potential, etc. energies}} = 0$$

$$\dot{E}_{\text{in}} = \dot{E}_{\text{out}}$$

$$\dot{m}_1 h_1 + \dot{m}_2 h_2 = \dot{m}_3 h_3 \quad (\text{since } \dot{Q} = \dot{W} = \Delta \text{ke} \cong \Delta \text{pe} \cong 0)$$

Combining the two gives

$$\dot{m} h_1 + \dot{m} h_2 = 2\dot{m} h_3 \quad \text{or} \quad h_3 = (h_1 + h_2)/2$$

Substituting,

$$h_3 = (33.08 + 1156.2)/2 = 594.6 \text{ Btu/lbm}$$

At 20 psia, $h_f = 196.27 \text{ Btu/lbm}$ and $h_g = 1156.2 \text{ Btu/lbm}$. Thus the exit stream is a saturated mixture since $h_f < h_3 < h_g$. Therefore,

$$T_3 = T_{\text{sat}} @ 20 \text{ psia} = \mathbf{228^\circ\text{F}}$$

and

$$x_3 = \frac{h_3 - h_f}{h_{fg}} = \frac{594.6 - 196.27}{1156.2 - 196.27} = \mathbf{0.415}$$

5-74 Two streams of refrigerant-134a are mixed in a chamber. If the cold stream enters at twice the rate of the hot stream, the temperature and quality (if saturated) of the exit stream are to be determined.

Assumptions 1 This is a steady-flow process since there is no change with time. **2** Kinetic and potential energy changes are negligible. **3** There are no work interactions. **4** The device is adiabatic and thus heat transfer is negligible.

Properties From R-134a tables (Tables A-11 through A-13),

$$h_1 \cong h_f @ 20^\circ\text{C} = 79.32 \text{ kJ/kg}$$

$$h_2 = h @ 1 \text{ MPa}, 80^\circ\text{C} = 314.27 \text{ kJ/kg}$$

Analysis We take the mixing chamber as the system, which is a control volume since mass crosses the boundary. The mass and energy balances for this steady-flow system can be expressed in the rate form as

Mass balance:

$$\begin{aligned} \dot{m}_{\text{in}} - \dot{m}_{\text{out}} &= \Delta \dot{m}_{\text{system}} \stackrel{\neq 0 \text{ (steady)}}{=} 0 \\ \dot{m}_{\text{in}} &= \dot{m}_{\text{out}} \\ \dot{m}_1 + \dot{m}_2 &= \dot{m}_3 = 3\dot{m}_2 \quad \text{since } \dot{m}_1 = 2\dot{m}_2 \end{aligned}$$

Energy balance:

$$\begin{aligned} \underbrace{\dot{E}_{\text{in}} - \dot{E}_{\text{out}}}_{\text{Rate of net energy transfer by heat, work, and mass}} &= \underbrace{\Delta \dot{E}_{\text{system}} \stackrel{\neq 0 \text{ (steady)}}{=}}_{\text{Rate of change in internal, kinetic, potential, etc. energies}} = 0 \\ \dot{E}_{\text{in}} &= \dot{E}_{\text{out}} \\ \dot{m}_1 h_1 + \dot{m}_2 h_2 &= \dot{m}_3 h_3 \quad (\text{since } \dot{Q} = \dot{W} = \Delta \text{ke} \cong \Delta \text{pe} \cong 0) \end{aligned}$$

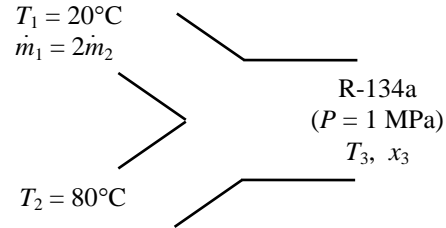

Combining the two gives

$$2\dot{m}_2 h_1 + \dot{m}_2 h_2 = 3\dot{m}_2 h_3 \quad \text{or } h_3 = (2h_1 + h_2)/3$$

Substituting,

$$h_3 = (2 \times 79.32 + 314.27)/3 = 157.64 \text{ kJ/kg}$$

At 1 MPa, $h_f = 107.34 \text{ kJ/kg}$ and $h_g = 271.04 \text{ kJ/kg}$. Thus the exit stream is a saturated mixture since $h_f < h_3 < h_g$. Therefore,

$$T_3 = T_{\text{sat}} @ 1 \text{ MPa} = \mathbf{39.37^\circ\text{C}}$$

and

$$x_3 = \frac{h_3 - h_f}{h_{fg}} = \frac{157.64 - 107.34}{271.04 - 107.34} = \mathbf{0.307}$$



5-75 Problem 5-74 is reconsidered. The effect of the mass flow rate of the cold stream of R-134a on the temperature and the quality of the exit stream as the ratio of the mass flow rate of the cold stream to that of the hot stream varies from 1 to 4 is to be investigated. The mixture temperature and quality are to be plotted against the cold-to-hot mass flow rate ratio.

Analysis The problem is solved using EES, and the solution is given below.

"Input Data"

```
m_frac = 2 "m_frac = m_dot_cold/m_dot_hot = m_dot_1/m_dot_2"
T[1]=20 [C]
P[1]=1000 [kPa]
T[2]=80 [C]
P[2]=1000 [kPa]
m_dot_1 = m_frac*m_dot_2
P[3]=1000 [kPa]
m_dot_1 = 1
```

"Conservation of mass for the R134a: Sum of m_dot_in = m_dot_out"

```
m_dot_1 + m_dot_2 = m_dot_3
```

"Conservation of Energy for steady-flow: neglect changes in KE and PE"

"We assume no heat transfer and no work occur across the control surface."

```
E_dot_in - E_dot_out = DELTAE_dot_cv
DELTAE_dot_cv = 0 "Steady-flow requirement"
E_dot_in = m_dot_1*h[1] + m_dot_2*h[2]
E_dot_out = m_dot_3*h[3]
```

"Property data are given by:"

```
h[1] = enthalpy(R134a, T=T[1], P=P[1])
h[2] = enthalpy(R134a, T=T[2], P=P[2])
T[3] = temperature(R134a, P=P[3], h=h[3])
x_3 = QUALITY(R134a, h=h[3], P=P[3])
```

m_{frac}	T_3 [C]	x_3
1	39.37	0.5467
1.25	39.37	0.467
1.5	39.37	0.4032
1.75	39.37	0.351
2	39.37	0.3075
2.25	39.37	0.2707
2.5	39.37	0.2392
2.75	39.37	0.2119
3	39.37	0.188
3.25	39.37	0.1668
3.5	39.37	0.1481
3.75	39.37	0.1313
4	39.37	0.1162

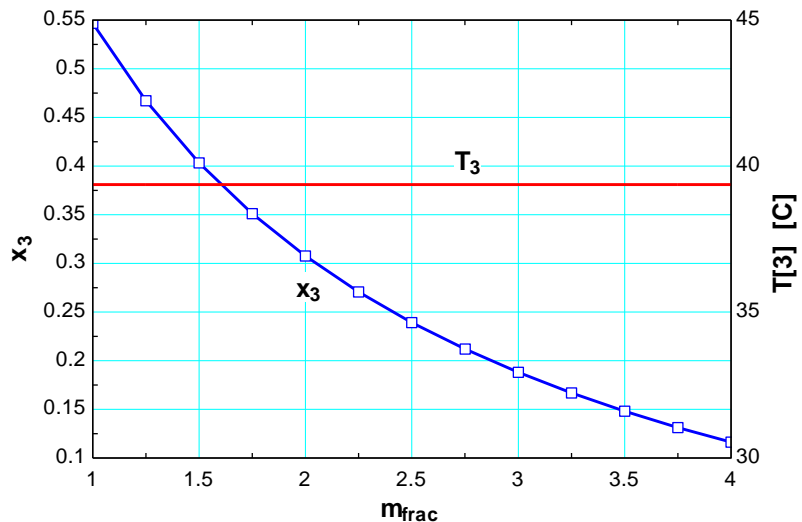

5-76 Water is heated in a heat exchanger by geothermal water. The rate of heat transfer to the water and the exit temperature of the geothermal water is to be determined.

Assumptions 1 Steady operating conditions exist. 2 The heat exchanger is well-insulated so that heat loss to the surroundings is negligible and thus heat transfer from the hot fluid is equal to the heat transfer to the cold fluid. 3 Changes in the kinetic and potential energies of fluid streams are negligible. 4 Fluid properties are constant.

Properties The specific heats of water and geothermal fluid are given to be 4.18 and 4.31 kJ/kg·°C, respectively.

Analysis We take the cold water tubes as the system, which is a control volume. The energy balance for this steady-flow system can be expressed in the rate form as

$$\underbrace{\dot{E}_{\text{in}} - \dot{E}_{\text{out}}}_{\text{Rate of net energy transfer by heat, work, and mass}} = \underbrace{\Delta \dot{E}_{\text{system}}}_{\text{Rate of change in internal, kinetic, potential, etc. energies}} \stackrel{\text{no (steady)}}{=} 0$$

$$\dot{E}_{\text{in}} = \dot{E}_{\text{out}}$$

$$\dot{Q}_{\text{in}} + \dot{m}h_1 = \dot{m}h_2 \quad (\text{since } \Delta ke \cong \Delta pe \cong 0)$$

$$\dot{Q}_{\text{in}} = \dot{m}c_p(T_2 - T_1)$$

Then the rate of heat transfer to the cold water in the heat exchanger becomes

$$\dot{Q} = [\dot{m}c_p(T_{\text{out}} - T_{\text{in}})]_{\text{water}} = (0.2 \text{ kg/s})(4.18 \text{ kJ/kg}\cdot\text{°C})(60\text{°C} - 25\text{°C}) = \mathbf{29.26 \text{ kW}}$$

Noting that heat transfer to the cold water is equal to the heat loss from the geothermal water, the outlet temperature of the geothermal water is determined from

$$\dot{Q} = [\dot{m}c_p(T_{\text{in}} - T_{\text{out}})]_{\text{geot. water}} \longrightarrow T_{\text{out}} = T_{\text{in}} - \frac{\dot{Q}}{\dot{m}c_p} = 140\text{°C} - \frac{29.26 \text{ kW}}{(0.3 \text{ kg/s})(4.31 \text{ kJ/kg}\cdot\text{°C})} = \mathbf{117.4\text{°C}}$$

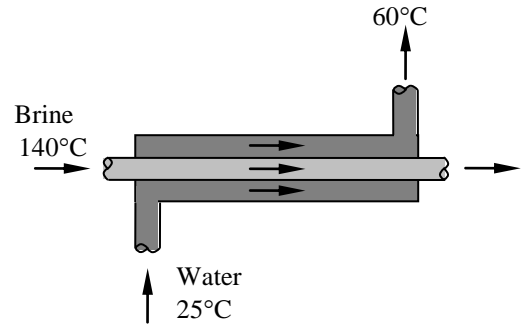

5-77E Steam is condensed by cooling water in a condenser. The rate of heat transfer in the heat exchanger and the rate of condensation of steam are to be determined.

Assumptions 1 Steady operating conditions exist. 2 The heat exchanger is well-insulated so that heat loss to the surroundings is negligible and thus heat transfer from the hot fluid is equal to the heat transfer to the cold fluid. 3 Changes in the kinetic and potential energies of fluid streams are negligible. 4 Fluid properties are constant.

Properties The specific heat of water is 1.0 Btu/lbm·°F (Table A-3E). The enthalpy of vaporization of water at 75°F is 1050.9 Btu/lbm (Table A-4E).

Analysis We take the tube-side of the heat exchanger where cold water is flowing as the system, which is a control volume. The energy balance for this steady-flow system can be expressed in the rate form as

$$\underbrace{\dot{E}_{\text{in}} - \dot{E}_{\text{out}}}_{\text{Rate of net energy transfer by heat, work, and mass}} = \underbrace{\Delta \dot{E}_{\text{system}}}_{\text{Rate of change in internal, kinetic, potential, etc. energies}} \stackrel{\text{no (steady)}}{=} 0$$

$$\dot{E}_{\text{in}} = \dot{E}_{\text{out}}$$

$$\dot{Q}_{\text{in}} + \dot{m}h_1 = \dot{m}h_2 \quad (\text{since } \Delta ke \cong \Delta pe \cong 0)$$

$$\dot{Q}_{\text{in}} = \dot{m}c_p(T_2 - T_1)$$

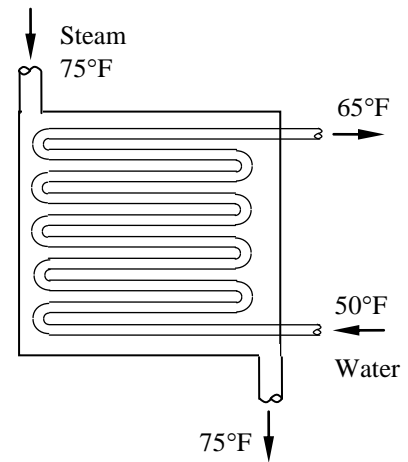

Then the rate of heat transfer to the cold water in this heat exchanger becomes

$$\dot{Q} = [\dot{m}c_p(T_{\text{out}} - T_{\text{in}})]_{\text{water}} = (45 \text{ lbm/s})(1.0 \text{ Btu/lbm}\cdot\text{°F})(65\text{°F} - 50\text{°F}) = \mathbf{675 \text{ Btu/s}}$$

Noting that heat gain by the water is equal to the heat loss by the condensing steam, the rate of condensation of the steam in the heat exchanger is determined from

$$\dot{Q} = (\dot{m}h_{fg})_{\text{steam}} \longrightarrow \dot{m}_{\text{steam}} = \frac{\dot{Q}}{h_{fg}} = \frac{675 \text{ Btu/s}}{1050.9 \text{ Btu/lbm}} = \mathbf{0.642 \text{ lbm/s}}$$

5-78 Oil is to be cooled by water in a thin-walled heat exchanger. The rate of heat transfer in the heat exchanger and the exit temperature of water is to be determined.

Assumptions 1 Steady operating conditions exist. 2 The heat exchanger is well-insulated so that heat loss to the surroundings is negligible and thus heat transfer from the hot fluid is equal to the heat transfer to the cold fluid. 3 Changes in the kinetic and potential energies of fluid streams are negligible. 4 Fluid properties are constant.

Properties The specific heats of water and oil are given to be 4.18 and 2.20 kJ/kg·°C, respectively.

Analysis We take the oil tubes as the system, which is a control volume. The energy balance for this steady-flow system can be expressed in the rate form as

$$\underbrace{\dot{E}_{\text{in}} - \dot{E}_{\text{out}}}_{\text{Rate of net energy transfer by heat, work, and mass}} = \underbrace{\Delta \dot{E}_{\text{system}}}_{\text{Rate of change in internal, kinetic, potential, etc. energies}} \stackrel{\text{no (steady)}}{=} 0$$

$$\dot{E}_{\text{in}} = \dot{E}_{\text{out}}$$

$$\dot{m}h_1 = \dot{Q}_{\text{out}} + \dot{m}h_2 \quad (\text{since } \Delta ke \cong \Delta pe \cong 0)$$

$$\dot{Q}_{\text{out}} = \dot{m}c_p(T_1 - T_2)$$

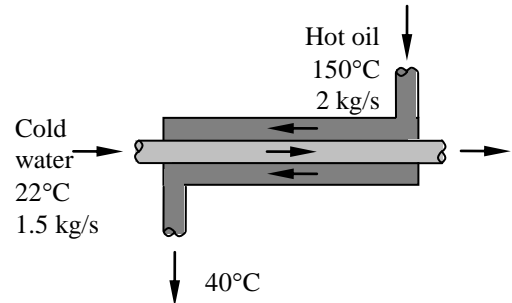

Then the rate of heat transfer from the oil becomes

$$\dot{Q} = [\dot{m}c_p(T_{\text{in}} - T_{\text{out}})]_{\text{oil}} = (2 \text{ kg/s})(2.2 \text{ kJ/kg}\cdot\text{°C})(150\text{°C} - 40\text{°C}) = \mathbf{484 \text{ kW}}$$

Noting that the heat lost by the oil is gained by the water, the outlet temperature of the water is determined from

$$\dot{Q} = [\dot{m}c_p(T_{\text{out}} - T_{\text{in}})]_{\text{water}} \longrightarrow T_{\text{out}} = T_{\text{in}} + \frac{\dot{Q}}{\dot{m}_{\text{water}}c_p} = 22\text{°C} + \frac{484 \text{ kJ/s}}{(1.5 \text{ kg/s})(4.18 \text{ kJ/kg}\cdot\text{°C})} = \mathbf{99.2\text{°C}}$$

5-79 Air is preheated by hot exhaust gases in a cross-flow heat exchanger. The rate of heat transfer and the outlet temperature of the air are to be determined.

Assumptions 1 Steady operating conditions exist. 2 The heat exchanger is well-insulated so that heat loss to the surroundings is negligible and thus heat transfer from the hot fluid is equal to the heat transfer to the cold fluid. 3 Changes in the kinetic and potential energies of fluid streams are negligible. 4 Fluid properties are constant.

Properties The specific heats of air and combustion gases are given to be 1.005 and 1.10 kJ/kg·°C, respectively.

Analysis We take the exhaust pipes as the system, which is a control volume. The energy balance for this steady-flow system can be expressed in the rate form as

$$\underbrace{\dot{E}_{\text{in}} - \dot{E}_{\text{out}}}_{\text{Rate of net energy transfer by heat, work, and mass}} = \underbrace{\Delta \dot{E}_{\text{system}}}_{\text{Rate of change in internal, kinetic, potential, etc. energies}} \stackrel{\text{no (steady)}}{=} 0 \rightarrow \dot{E}_{\text{in}} = \dot{E}_{\text{out}}$$

$$\dot{m}h_1 = \dot{Q}_{\text{out}} + \dot{m}h_2 \quad (\text{since } \Delta \text{ke} \cong \Delta \text{pe} \cong 0)$$

$$\dot{Q}_{\text{out}} = \dot{m}c_p(T_1 - T_2)$$

Then the rate of heat transfer from the exhaust gases becomes

$$\begin{aligned} \dot{Q} &= [\dot{m}c_p(T_{\text{in}} - T_{\text{out}})]_{\text{gas}} \\ &= (0.95 \text{ kg/s})(1.1 \text{ kJ/kg}\cdot\text{°C})(160\text{°C} - 95\text{°C}) \\ &= \mathbf{67.93 \text{ kW}} \end{aligned}$$

The mass flow rate of air is

$$\dot{m} = \frac{P\dot{V}}{RT} = \frac{(95 \text{ kPa})(0.6 \text{ m}^3/\text{s})}{(0.287 \text{ kPa}\cdot\text{m}^3/\text{kg}\cdot\text{K}) \times 293 \text{ K}} = 0.6778 \text{ kg/s}$$

Noting that heat loss by the exhaust gases is equal to the heat gain by the air, the outlet temperature of the air becomes

$$\dot{Q} = \dot{m}c_p(T_{\text{c,out}} - T_{\text{c,in}}) \rightarrow T_{\text{c,out}} = T_{\text{c,in}} + \frac{\dot{Q}}{\dot{m}c_p} = 20\text{°C} + \frac{67.93 \text{ kW}}{(0.6778 \text{ kg/s})(1.005 \text{ kJ/kg}\cdot\text{°C})} = \mathbf{120\text{°C}}$$

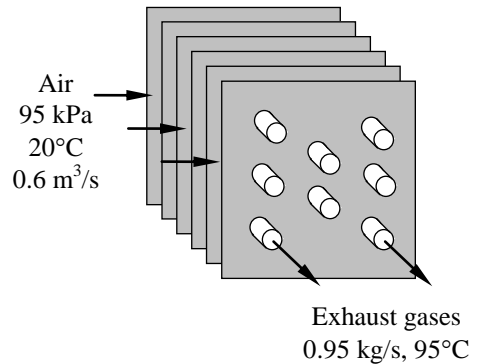

5-80E  Air is heated in a steam heating system. For specified flow rates, the volume flow rate of air at the inlet is to be determined.

Assumptions **1** This is a steady-flow process since there is no change with time. **2** Kinetic and potential energy changes are negligible. **3** There are no work interactions. **4** Heat loss from the device to the surroundings is negligible and thus heat transfer from the hot fluid is equal to the heat transfer to the cold fluid. **5** Air is an ideal gas with constant specific heats at room temperature.

Properties The gas constant of air is $0.3704 \text{ psia}\cdot\text{ft}^3/\text{lbm}\cdot\text{R}$ (Table A-1E). The constant pressure specific heat of air is $c_p = 0.240 \text{ Btu}/\text{lbm}\cdot^\circ\text{F}$ (Table A-2E). The enthalpies of steam at the inlet and the exit states are (Tables A-4E through A-6E)

$$\left. \begin{array}{l} P_3 = 30 \text{ psia} \\ T_3 = 400^\circ\text{F} \end{array} \right\} h_3 = 1237.9 \text{ Btu}/\text{lbm}$$

$$\left. \begin{array}{l} P_4 = 25 \text{ psia} \\ T_4 = 212^\circ\text{F} \end{array} \right\} h_4 \cong h_{f@212^\circ\text{F}} = 180.21 \text{ Btu}/\text{lbm}$$

Analysis We take the entire heat exchanger as the system, which is a control volume. The mass and energy balances for this steady-flow system can be expressed in the rate form as

Mass balance (for each fluid stream):

$$\dot{m}_{\text{in}} - \dot{m}_{\text{out}} = \Delta \dot{m}_{\text{system}} \stackrel{\approx 0 \text{ (steady)}}{=} 0$$

$$\dot{m}_{\text{in}} = \dot{m}_{\text{out}}$$

$$\dot{m}_1 = \dot{m}_2 = \dot{m}_a \quad \text{and} \quad \dot{m}_3 = \dot{m}_4 = \dot{m}_s$$

Energy balance (for the entire heat exchanger):

$$\underbrace{\dot{E}_{\text{in}} - \dot{E}_{\text{out}}}_{\text{Rate of net energy transfer by heat, work, and mass}} = \underbrace{\Delta \dot{E}_{\text{system}}}_{\text{Rate of change in internal, kinetic, potential, etc. energies}} \stackrel{\approx 0 \text{ (steady)}}{=} 0$$

$$\dot{E}_{\text{in}} = \dot{E}_{\text{out}}$$

$$\dot{m}_1 h_1 + \dot{m}_3 h_3 = \dot{m}_2 h_2 + \dot{m}_4 h_4 \quad (\text{since } \dot{Q} = \dot{W} = \Delta \text{ke} \cong \Delta \text{pe} \cong 0)$$

Combining the two, $\dot{m}_a (h_2 - h_1) = \dot{m}_s (h_3 - h_4)$

Solving for \dot{m}_a :

$$\dot{m}_a = \frac{h_3 - h_4}{h_2 - h_1} \dot{m}_s \cong \frac{h_3 - h_4}{c_p (T_2 - T_1)} \dot{m}_s$$

Substituting,

$$\dot{m}_a = \frac{(1237.9 - 180.21) \text{ Btu}/\text{lbm}}{(0.240 \text{ Btu}/\text{lbm}\cdot^\circ\text{F})(130 - 80)^\circ\text{F}} (15 \text{ lbm}/\text{min}) = 1322 \text{ lbm}/\text{min} = 22.04 \text{ lbm}/\text{s}$$

Also,

$$\nu_1 = \frac{RT_1}{P_1} = \frac{(0.3704 \text{ psia}\cdot\text{ft}^3/\text{lbm}\cdot\text{R})(540 \text{ R})}{14.7 \text{ psia}} = 13.61 \text{ ft}^3/\text{lbm}$$

Then the volume flow rate of air at the inlet becomes

$$\dot{\mathcal{V}}_1 = \dot{m}_a \nu_1 = (22.04 \text{ lbm}/\text{s})(13.61 \text{ ft}^3/\text{lbm}) = \mathbf{300 \text{ ft}^3/\text{s}}$$

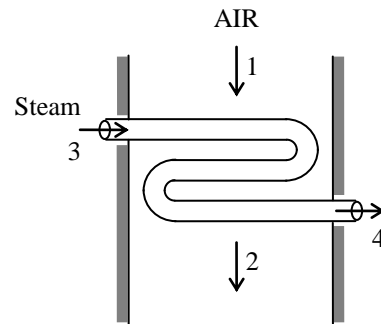

5-81 Refrigerant-134a is to be cooled by air in the condenser. For a specified volume flow rate of air, the mass flow rate of the refrigerant is to be determined.

Assumptions 1 This is a steady-flow process since there is no change with time. **2** Kinetic and potential energy changes are negligible. **3** There are no work interactions. **4** Heat loss from the device to the surroundings is negligible and thus heat transfer from the hot fluid is equal to the heat transfer to the cold fluid. **5** Air is an ideal gas with constant specific heats at room temperature.

Properties The gas constant of air is $0.287 \text{ kPa}\cdot\text{m}^3/\text{kg}\cdot\text{K}$ (Table A-1). The constant pressure specific heat of air is $c_p = 1.005 \text{ kJ/kg}\cdot^\circ\text{C}$ (Table A-2). The enthalpies of the R-134a at the inlet and the exit states are (Tables A-11 through A-13)

$$\left. \begin{array}{l} P_3 = 1 \text{ MPa} \\ T_3 = 90^\circ\text{C} \end{array} \right\} h_3 = 324.66 \text{ kJ/kg}$$

$$\left. \begin{array}{l} P_4 = 1 \text{ MPa} \\ T_4 = 30^\circ\text{C} \end{array} \right\} h_4 \cong h_{f@30^\circ\text{C}} = 93.58 \text{ kJ/kg}$$

Analysis The inlet specific volume and the mass flow rate of air are

$$\nu_1 = \frac{RT_1}{P_1} = \frac{(0.287 \text{ kPa}\cdot\text{m}^3/\text{kg}\cdot\text{K})(300 \text{ K})}{100 \text{ kPa}} = 0.861 \text{ m}^3/\text{kg}$$

and

$$\dot{m} = \frac{\dot{V}_1}{\nu_1} = \frac{600 \text{ m}^3/\text{min}}{0.861 \text{ m}^3/\text{kg}} = 696.9 \text{ kg/min}$$

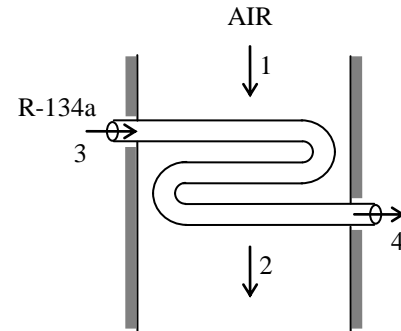

We take the entire heat exchanger as the system, which is a control volume. The mass and energy balances for this steady-flow system can be expressed in the rate form as

Mass balance (for each fluid stream):

$$\dot{m}_{\text{in}} - \dot{m}_{\text{out}} = \Delta \dot{m}_{\text{system}} \stackrel{\approx 0 \text{ (steady)}}{=} 0 \rightarrow \dot{m}_{\text{in}} = \dot{m}_{\text{out}} \rightarrow \dot{m}_1 = \dot{m}_2 = \dot{m}_a \text{ and } \dot{m}_3 = \dot{m}_4 = \dot{m}_R$$

Energy balance (for the entire heat exchanger):

$$\underbrace{\dot{E}_{\text{in}} - \dot{E}_{\text{out}}}_{\text{Rate of net energy transfer by heat, work, and mass}} = \underbrace{\Delta \dot{E}_{\text{system}}}_{\text{Rate of change in internal, kinetic, potential, etc. energies}} \stackrel{\approx 0 \text{ (steady)}}{=} 0$$

$$\dot{E}_{\text{in}} = \dot{E}_{\text{out}}$$

$$\dot{m}_1 h_1 + \dot{m}_3 h_3 = \dot{m}_2 h_2 + \dot{m}_4 h_4 \quad (\text{since } \dot{Q} = \dot{W} = \Delta \text{ke} \cong \Delta \text{pe} \cong 0)$$

Combining the two,

$$\dot{m}_a (h_2 - h_1) = \dot{m}_R (h_3 - h_4)$$

Solving for \dot{m}_R :

$$\dot{m}_R = \frac{h_2 - h_1}{h_3 - h_4} \dot{m}_a \cong \frac{c_p (T_2 - T_1)}{h_3 - h_4} \dot{m}_a$$

Substituting,

$$\dot{m}_R = \frac{(1.005 \text{ kJ/kg}\cdot^\circ\text{C})(60 - 27)^\circ\text{C}}{(324.66 - 93.58) \text{ kJ/kg}} (696.9 \text{ kg/min}) = \mathbf{100.0 \text{ kg/min}}$$

5-82E Refrigerant-134a is vaporized by air in the evaporator of an air-conditioner. For specified flow rates, the exit temperature of the air and the rate of heat transfer from the air are to be determined.

Assumptions 1 This is a steady-flow process since there is no change with time. **2** Kinetic and potential energy changes are negligible. **3** There are no work interactions. **4** Heat loss from the device to the surroundings is negligible and thus heat transfer from the hot fluid is equal to the heat transfer to the cold fluid. **5** Air is an ideal gas with constant specific heats at room temperature.

Properties The gas constant of air is $0.3704 \text{ psia}\cdot\text{ft}^3/\text{lbm}\cdot\text{R}$ (Table A-1E). The constant pressure specific heat of air is $c_p = 0.240 \text{ Btu/lbm}\cdot^\circ\text{F}$ (Table A-2E). The enthalpies of the R-134a at the inlet and the exit states are (Tables A-11E through A-13E)

$$\left. \begin{array}{l} P_3 = 20 \text{ psia} \\ x_3 = 0.3 \end{array} \right\} h_3 = h_f + x_3 h_{fg} = 11.436 + 0.3 \times 91.302 = 38.83 \text{ Btu/lbm}$$

$$\left. \begin{array}{l} P_4 = 20 \text{ psia} \\ \text{sat. vapor} \end{array} \right\} h_4 = h_g @ 20 \text{ psia} = 102.74 \text{ Btu/lbm}$$

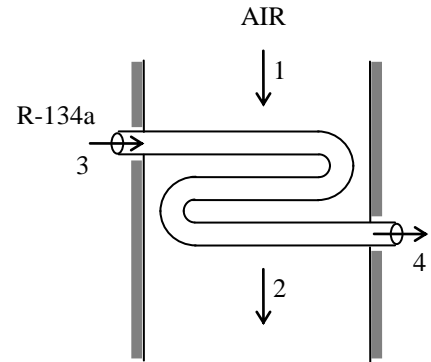

Analysis (a) The inlet specific volume and the mass flow rate of air are

$$v_1 = \frac{RT_1}{P_1} = \frac{(0.3704 \text{ psia}\cdot\text{ft}^3/\text{lbm}\cdot\text{R})(550 \text{ R})}{14.7 \text{ psia}} = 13.86 \text{ ft}^3/\text{lbm}$$

and

$$\dot{m} = \frac{\dot{V}_1}{v_1} = \frac{200 \text{ ft}^3/\text{min}}{13.86 \text{ ft}^3/\text{lbm}} = 14.43 \text{ lbm/min}$$

We take the entire heat exchanger as the system, which is a control volume. The mass and energy balances for this steady-flow system can be expressed in the rate form as

Mass balance (for each fluid stream):

$$\dot{m}_{\text{in}} - \dot{m}_{\text{out}} = \Delta \dot{m}_{\text{system}} \stackrel{\approx 0 \text{ (steady)}}{=} 0 \rightarrow \dot{m}_{\text{in}} = \dot{m}_{\text{out}} \rightarrow \dot{m}_1 = \dot{m}_2 = \dot{m}_a \text{ and } \dot{m}_3 = \dot{m}_4 = \dot{m}_R$$

Energy balance (for the entire heat exchanger):

$$\underbrace{\dot{E}_{\text{in}} - \dot{E}_{\text{out}}}_{\text{Rate of net energy transfer by heat, work, and mass}} = \underbrace{\Delta \dot{E}_{\text{system}} \stackrel{\approx 0 \text{ (steady)}}{=}}_{\text{Rate of change in internal, kinetic, potential, etc. energies}} = 0$$

$$\dot{E}_{\text{in}} = \dot{E}_{\text{out}}$$

$$\dot{m}_1 h_1 + \dot{m}_3 h_3 = \dot{m}_2 h_2 + \dot{m}_4 h_4 \quad (\text{since } \dot{Q} = \dot{W} = \Delta \text{ke} \cong \Delta \text{pe} \cong 0)$$

Combining the two,

$$\dot{m}_R (h_3 - h_4) = \dot{m}_a (h_2 - h_1) = \dot{m}_a c_p (T_2 - T_1)$$

$$\text{Solving for } T_2: \quad T_2 = T_1 + \frac{\dot{m}_R (h_3 - h_4)}{\dot{m}_a c_p}$$

$$\text{Substituting,} \quad T_2 = 90^\circ\text{F} + \frac{(4 \text{ lbm/min})(38.83 - 102.74) \text{ Btu/lbm}}{(14.43 \text{ Btu/min})(0.24 \text{ Btu/lbm}\cdot^\circ\text{F})} = \mathbf{16.2^\circ\text{F}}$$

(b) The rate of heat transfer from the air to the refrigerant is determined from the steady-flow energy balance applied to the air only. It yields

$$\begin{aligned} -\dot{Q}_{\text{air,out}} &= \dot{m}_a (h_2 - h_1) = \dot{m}_a c_p (T_2 - T_1) \\ \dot{Q}_{\text{air,out}} &= -(14.43 \text{ lbm/min})(0.24 \text{ Btu/lbm}\cdot^\circ\text{F})(16.2 - 90)^\circ\text{F} \\ &= \mathbf{255.6 \text{ Btu/min}} \end{aligned}$$

5-83 Two streams of cold and warm air are mixed in a chamber. If the ratio of hot to cold air is 1.6, the mixture temperature and the rate of heat gain of the room are to be determined.

Assumptions 1 This is a steady-flow process since there is no change with time. **2** Kinetic and potential energy changes are negligible. **3** There are no work interactions. **4** The device is adiabatic and thus heat transfer is negligible.

Properties The gas constant of air is $R = 0.287$ kPa·m³/kg·K. The enthalpies of air are obtained from air table (Table A-17) as

$$h_1 = h_{@280\text{ K}} = 280.13 \text{ kJ/kg}$$

$$h_2 = h_{@307\text{ K}} = 307.23 \text{ kJ/kg}$$

$$h_{\text{room}} = h_{@297\text{ K}} = 297.18 \text{ kJ/kg}$$

Analysis (a) We take the mixing chamber as the system, which is a control volume since mass crosses the boundary. The mass and energy balances for this steady-flow system can be expressed in the rate form as

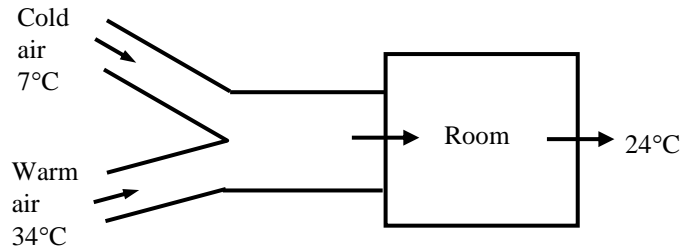

Mass balance:

$$\dot{m}_{\text{in}} - \dot{m}_{\text{out}} = \Delta \dot{m}_{\text{system}}^{\text{no (steady)}} = 0 \rightarrow \dot{m}_{\text{in}} = \dot{m}_{\text{out}} \rightarrow \dot{m}_1 + 1.6\dot{m}_1 = \dot{m}_3 = 2.6\dot{m}_1 \text{ since } \dot{m}_2 = 1.6\dot{m}_1$$

Energy balance:

$$\underbrace{\dot{E}_{\text{in}} - \dot{E}_{\text{out}}}_{\text{Rate of net energy transfer by heat, work, and mass}} = \underbrace{\Delta \dot{E}_{\text{system}}^{\text{no (steady)}}}_{\text{Rate of change in internal, kinetic, potential, etc. energies}} = 0$$

$$\dot{E}_{\text{in}} = \dot{E}_{\text{out}}$$

$$\dot{m}_1 h_1 + \dot{m}_2 h_2 = \dot{m}_3 h_3 \quad (\text{since } \dot{Q} \cong \dot{W} \cong \Delta ke \cong \Delta pe \cong 0)$$

Combining the two gives $\dot{m}_1 h_1 + 1.6\dot{m}_1 h_2 = 2.6\dot{m}_1 h_3$ or $h_3 = (h_1 + 1.6h_2)/2.6$

Substituting,

$$h_3 = (280.13 + 1.6 \times 307.23)/2.6 = 296.81 \text{ kJ/kg}$$

From air table at this enthalpy, the mixture temperature is

$$T_3 = T_{@h=296.81 \text{ kJ/kg}} = 296.6 \text{ K} = \mathbf{23.6^\circ\text{C}}$$

(b) The mass flow rates are determined as follows

$$\nu_1 = \frac{RT_1}{P} = \frac{(0.287 \text{ kPa} \cdot \text{m}^3/\text{kg} \cdot \text{K})(7 + 273 \text{ K})}{105 \text{ kPa}} = 0.7654 \text{ m}^3/\text{kg}$$

$$\dot{m}_1 = \frac{\dot{V}_1}{\nu_1} = \frac{0.55 \text{ m}^3/\text{s}}{0.7654 \text{ m}^3/\text{kg}} = 0.7186 \text{ kg/s}$$

$$\dot{m}_3 = 2.6\dot{m}_1 = 2.6(0.7186 \text{ kg/s}) = 1.868 \text{ kg/s}$$

The rate of heat gain of the room is determined from

$$\dot{Q}_{\text{gain}} = \dot{m}_3(h_{\text{room}} - h_3) = (1.868 \text{ kg/s})(297.18 - 296.81) \text{ kJ/kg} = \mathbf{0.691 \text{ kW}}$$

Therefore, the room gains heat at a rate of 0.691 kW.

5-84 A heat exchanger that is not insulated is used to produce steam from the heat given up by the exhaust gases of an internal combustion engine. The temperature of exhaust gases at the heat exchanger exit and the rate of heat transfer to the water are to be determined.

Assumptions 1 This is a steady-flow process since there is no change with time. **2** Kinetic and potential energy changes are negligible. **3** There are no work interactions. **4** Exhaust gases are assumed to have air properties with constant specific heats.

Properties The constant pressure specific heat of the exhaust gases is taken to be $c_p = 1.045 \text{ kJ/kg}\cdot^\circ\text{C}$ (Table A-2). The inlet and exit enthalpies of water are (Tables A-4 and A-5)

$$\left. \begin{array}{l} T_{w,\text{in}} = 15^\circ\text{C} \\ x = 0 \text{ (sat. liq.)} \end{array} \right\} h_{w,\text{in}} = 62.98 \text{ kJ/kg}$$

$$\left. \begin{array}{l} P_{w,\text{out}} = 2 \text{ MPa} \\ x = 1 \text{ (sat. vap.)} \end{array} \right\} h_{w,\text{out}} = 2798.3 \text{ kJ/kg}$$

Analysis We take the entire heat exchanger as the system, which is a control volume. The mass and energy balances for this steady-flow system can be expressed in the rate form as

Mass balance (for each fluid stream):

$$\dot{m}_{\text{in}} - \dot{m}_{\text{out}} = \Delta \dot{m}_{\text{system}} \stackrel{\approx 0 \text{ (steady)}}{=} 0 \longrightarrow \dot{m}_{\text{in}} = \dot{m}_{\text{out}}$$

Energy balance (for the entire heat exchanger):

$$\underbrace{\dot{E}_{\text{in}} - \dot{E}_{\text{out}}}_{\text{Rate of net energy transfer by heat, work, and mass}} = \underbrace{\Delta \dot{E}_{\text{system}}}_{\text{Rate of change in internal, kinetic, potential, etc. energies}} \stackrel{\approx 0 \text{ (steady)}}{=} 0$$

$$\dot{E}_{\text{in}} = \dot{E}_{\text{out}}$$

$$\dot{m}_{\text{exh}} h_{\text{exh},\text{in}} + \dot{m}_{\text{w}} h_{w,\text{in}} = \dot{m}_{\text{exh}} h_{\text{exh},\text{out}} + \dot{m}_{\text{w}} h_{w,\text{out}} + \dot{Q}_{\text{out}} \quad (\text{since } \dot{W} = \Delta \text{ke} \cong \Delta \text{pe} \cong 0)$$

or
$$\dot{m}_{\text{exh}} c_p T_{\text{exh},\text{in}} + \dot{m}_{\text{w}} h_{w,\text{in}} = \dot{m}_{\text{exh}} c_p T_{\text{exh},\text{out}} + \dot{m}_{\text{w}} h_{w,\text{out}} + \dot{Q}_{\text{out}}$$

Noting that the mass flow rate of exhaust gases is 15 times that of the water, substituting gives

$$15\dot{m}_{\text{w}} (1.045 \text{ kJ/kg}\cdot^\circ\text{C})(400^\circ\text{C}) + \dot{m}_{\text{w}} (62.98 \text{ kJ/kg}) = 15\dot{m}_{\text{w}} (1.045 \text{ kJ/kg}\cdot^\circ\text{C})T_{\text{exh},\text{out}} + \dot{m}_{\text{w}} (2798.3 \text{ kJ/kg}) + \dot{Q}_{\text{out}} \quad (1)$$

The heat given up by the exhaust gases and heat picked up by the water are

$$\dot{Q}_{\text{exh}} = \dot{m}_{\text{exh}} c_p (T_{\text{exh},\text{in}} - T_{\text{exh},\text{out}}) = 15\dot{m}_{\text{w}} (1.045 \text{ kJ/kg}\cdot^\circ\text{C})(400 - T_{\text{exh},\text{out}})^\circ\text{C} \quad (2)$$

$$\dot{Q}_{\text{w}} = \dot{m}_{\text{w}} (h_{w,\text{out}} - h_{w,\text{in}}) = \dot{m}_{\text{w}} (2798.3 - 62.98) \text{ kJ/kg} \quad (3)$$

The heat loss is

$$\dot{Q}_{\text{out}} = f_{\text{heat loss}} \dot{Q}_{\text{exh}} = 0.1 \dot{Q}_{\text{exh}} \quad (4)$$

The solution may be obtained by a trial-error approach. Or, solving the above equations simultaneously using EES software, we obtain

$$T_{\text{exh},\text{out}} = \mathbf{206.1^\circ\text{C}}, \quad \dot{Q}_{\text{w}} = \mathbf{97.26 \text{ kW}}, \quad \dot{m}_{\text{w}} = 0.03556 \text{ kg/s}, \quad \dot{m}_{\text{exh}} = 0.5333 \text{ kg/s}$$

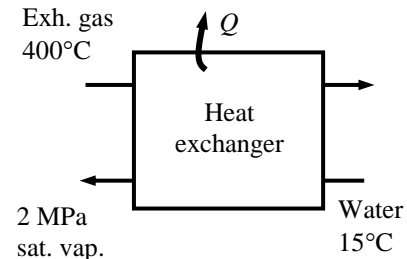

5-85 Refrigerant-22 is evaporated in an evaporator by air. The rate of heat transfer from the air and the temperature change of air are to be determined.

Assumptions 1 This is a steady-flow process since there is no change with time. **2** Kinetic and potential energy changes are negligible. **3** There are no work and heat interactions between the evaporator and the surroundings.

Analysis We take the condenser as the system, which is a control volume. The energy balance for this steady-flow system can be expressed in the rate form as

$$\underbrace{\dot{E}_{\text{in}} - \dot{E}_{\text{out}}}_{\text{Rate of net energy transfer by heat, work, and mass}} = \underbrace{\Delta \dot{E}_{\text{system}}}_{\text{Rate of change in internal, kinetic, potential, etc. energies}} \stackrel{\text{no (steady)}}{=} 0$$

$$\dot{E}_{\text{in}} = \dot{E}_{\text{out}}$$

$$\dot{m}_R h_1 + \dot{m}_a h_3 = \dot{m}_R h_2 + \dot{m}_a h_4$$

$$\dot{m}_R (h_2 - h_1) = \dot{m}_a (h_3 - h_4) = \dot{m}_a c_p \Delta T_a$$

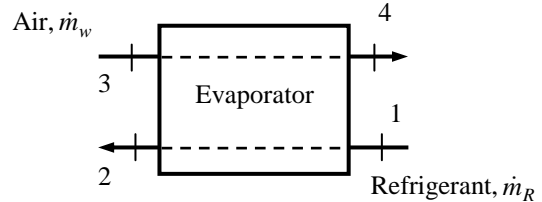

If we take the refrigerant as the system, the energy balance can be written as

$$\underbrace{\dot{E}_{\text{in}} - \dot{E}_{\text{out}}}_{\text{Rate of net energy transfer by heat, work, and mass}} = \underbrace{\Delta \dot{E}_{\text{system}}}_{\text{Rate of change in internal, kinetic, potential, etc. energies}} \stackrel{\text{no (steady)}}{=} 0$$

$$\dot{E}_{\text{in}} = \dot{E}_{\text{out}}$$

$$\dot{m}_R h_1 + \dot{Q}_{\text{in}} = \dot{m}_R h_2$$

$$\dot{Q}_{\text{in}} = \dot{m}_R (h_2 - h_1)$$

(a) The mass flow rate of the refrigerant is

$$\dot{m}_R = \frac{\dot{V}_1}{v_1} = \frac{(2.65/3600) \text{ m}^3/\text{s}}{0.0253 \text{ m}^3/\text{kg}} = 0.02910 \text{ kg/s}$$

The rate of heat absorbed from the air is

$$\dot{Q}_{\text{in}} = \dot{m}_R (h_2 - h_1) = (0.02910 \text{ kg/s})(398.0 - 220.2) \text{ kJ/kg} = \mathbf{5.17 \text{ kW}}$$

(b) The temperature change of air can be determined from an energy balance on the evaporator:

$$\dot{Q}_L = \dot{m}_R (h_3 - h_2) = \dot{m}_a c_p (T_{a1} - T_{a2})$$

$$5.17 \text{ kW} = (0.75 \text{ kg/s})(1.005 \text{ kJ/kg} \cdot ^\circ\text{C}) \Delta T_a$$

$$\Delta T_a = \mathbf{6.9^\circ\text{C}}$$

The specific heat of air is taken as 1.005 kJ/kg \cdot °C (Table A-2).

5-86 Steam is condensed by cooling water in the condenser of a power plant. The rate of condensation of steam is to be determined.

Assumptions 1 Steady operating conditions exist. 2 The heat exchanger is well-insulated so that heat loss to the surroundings is negligible and thus heat transfer from the hot fluid is equal to the heat transfer to the cold fluid. 3 Changes in the kinetic and potential energies of fluid streams are negligible. 4 Fluid properties are constant.

Properties The heat of vaporization of water at 50°C is $h_{fg} = 2382.0$ kJ/kg and specific heat of cold water is $c_p = 4.18$ kJ/kg·°C (Tables A-3 and A-4).

Analysis We take the cold water tubes as the system, which is a control volume. The energy balance for this steady-flow system can be expressed in the rate form as

$$\underbrace{\dot{E}_{in} - \dot{E}_{out}}_{\text{Rate of net energy transfer by heat, work, and mass}} = \underbrace{\Delta \dot{E}_{system}}_{\text{Rate of change in internal, kinetic, potential, etc. energies}} \stackrel{\text{no (steady)}}{=} 0$$

$$\dot{E}_{in} = \dot{E}_{out}$$

$$\dot{Q}_{in} + \dot{m}h_1 = \dot{m}h_2 \quad (\text{since } \Delta ke \cong \Delta pe \cong 0)$$

$$\dot{Q}_{in} = \dot{m}c_p(T_2 - T_1)$$

Then the heat transfer rate to the cooling water in the condenser becomes

$$\begin{aligned} \dot{Q} &= [\dot{m}c_p(T_{out} - T_{in})]_{\text{cooling water}} \\ &= (101 \text{ kg/s})(4.18 \text{ kJ/kg}\cdot\text{°C})(27\text{°C} - 18\text{°C}) \\ &= 3800 \text{ kJ/s} \end{aligned}$$

The rate of condensation of steam is determined to be

$$\dot{Q} = (\dot{m}h_{fg})_{\text{steam}} \longrightarrow \dot{m}_{\text{steam}} = \frac{\dot{Q}}{h_{fg}} = \frac{3800 \text{ kJ/s}}{2382.0 \text{ kJ/kg}} = \mathbf{1.60 \text{ kg/s}}$$

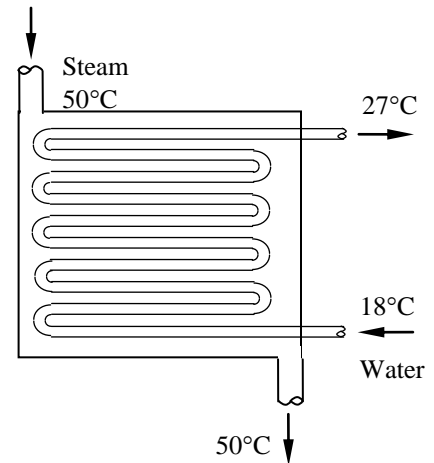



5-87 Problem 5-86 is reconsidered. The effect of the inlet temperature of cooling water on the rate of condensation of steam as the inlet temperature varies from 10°C to 20°C at constant exit temperature is to be investigated. The rate of condensation of steam is to be plotted against the inlet temperature of the cooling water.

Analysis The problem is solved using EES, and the solution is given below.

"Input Data"

T_s[1]=50 [C]
 T_s[2]=50 [C]
 m_dot_water=101 [kg/s]
 T_water[1]=18 [C]
 T_water[2]=27 [C]
 C_P_water = 4.20 [kJ/kg-°C]

"Conservation of mass for the steam: m_dot_s_in=m_dot_s_out=m_dot_s"

"Conservation of mass for the water: m_dot_water_in=lm_dot_water_out=m_dot_water"

"Conservation of Energy for steady-flow: neglect changes in KE and PE"

"We assume no heat transfer and no work occur across the control surface."

E_dot_in - E_dot_out = DELTAE_dot_cv

DELTAE_dot_cv=0 "Steady-flow requirement"

E_dot_in=m_dot_s*h_s[1] + m_dot_water*h_water[1]

E_dot_out=m_dot_s*h_s[2] + m_dot_water*h_water[2]

"Property data are given by:"

h_s[1] =enthalpy(steam_iapws,T=T_s[1],x=1) "steam data"

h_s[2] =enthalpy(steam_iapws,T=T_s[2],x=0)

h_water[1] =C_P_water*T_water[1] "water data"

h_water[2] =C_P_water*T_water[2]

h_fg_s=h_s[1]-h_s[2] "h_fg is found from the EES functions rather than using h_fg = 2305 kJ/kg"

m _s [kg/s]	T _{water,1} [C]
3.028	10
2.671	12
2.315	14
1.959	16
1.603	18
1.247	20

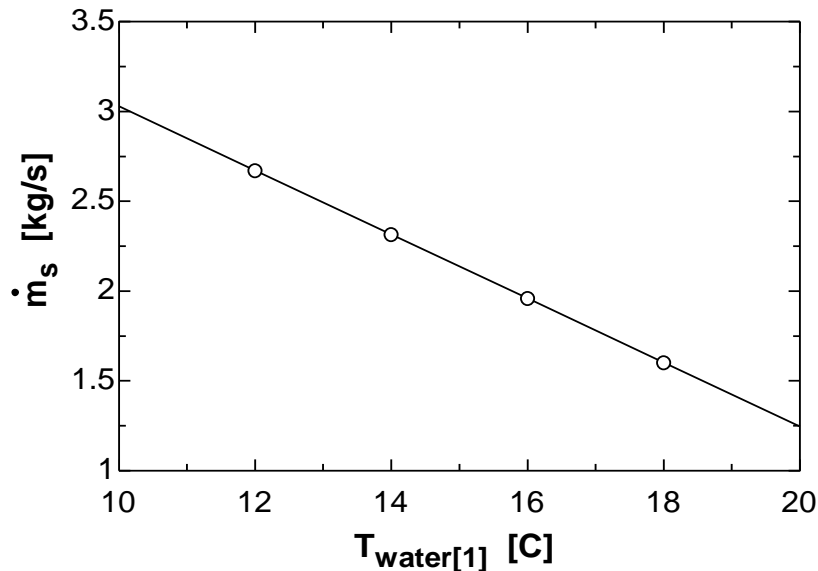

5-88 Two mass streams of the same ideal gas are mixed in a mixing chamber. Heat is transferred to the chamber. Three expressions as functions of other parameters are to be obtained.

Assumptions 1 This is a steady-flow process since there is no change with time. **2** Kinetic and potential energy changes are negligible. **3** There are no work interactions.

Analysis (a) We take the mixing device as the system, which is a control volume. The energy balance for this steady-flow system can be expressed in the rate form as

$$\underbrace{\dot{E}_{\text{in}} - \dot{E}_{\text{out}}}_{\text{Rate of net energy transfer by heat, work, and mass}} = \underbrace{\Delta \dot{E}_{\text{system}}}_{\text{Rate of change in internal, kinetic, potential, etc. energies}} \stackrel{\text{no (steady)}}{=} 0$$

$$\dot{E}_{\text{in}} = \dot{E}_{\text{out}}$$

$$\dot{m}_1 h_1 + \dot{m}_2 h_2 + \dot{Q}_{\text{in}} = \dot{m}_3 h_3$$

From a mass balance,

$$\dot{m}_3 = \dot{m}_1 + \dot{m}_2$$

Since $h = c_p T$,

Then

$$\dot{m}_1 c_p T_1 + \dot{m}_2 c_p T_2 + \dot{Q}_{\text{in}} = \dot{m}_3 c_p T_3$$

$$T_3 = \frac{\dot{m}_1}{\dot{m}_3} T_1 + \frac{\dot{m}_2}{\dot{m}_3} T_2 + \frac{\dot{Q}_{\text{in}}}{\dot{m}_3 c_p}$$

(b) Expression for volume flow rate:

$$\dot{V}_3 = \dot{m}_3 \nu_3 = \dot{m}_3 \frac{RT_3}{P_3}$$

$$\dot{V}_3 = \frac{\dot{m}_3 R}{P_3} \left(\frac{\dot{m}_1}{\dot{m}_3} T_1 + \frac{\dot{m}_2}{\dot{m}_3} T_2 + \frac{\dot{Q}_{\text{in}}}{\dot{m}_3 c_p} \right)$$

$$P_3 = P_1 = P_2 = P$$

$$\dot{V}_3 = \frac{\dot{m}_1 R T_1}{P_1} + \frac{\dot{m}_2 R T_2}{P_2} + \frac{R \dot{Q}_{\text{in}}}{P_3 c_p}$$

$$\dot{V}_3 = \dot{V}_1 + \dot{V}_2 + \frac{R \dot{Q}_{\text{in}}}{P c_p}$$

(c) If the process is adiabatic, then

$$\dot{V}_3 = \dot{V}_1 + \dot{V}_2$$

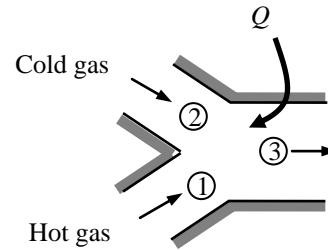

Pipe and duct Flow

5-89E Saturated liquid water is heated in a steam boiler. The heat transfer per unit mass is to be determined.

Assumptions 1 This is a steady-flow process since there is no change with time. **2** Kinetic and potential energy changes are negligible. **3** There are no work interactions.

Analysis We take the pipe in which the water is heated as the system, which is a control volume. The energy balance for this steady-flow system can be expressed in the rate form as

$$\underbrace{\dot{E}_{\text{in}} - \dot{E}_{\text{out}}}_{\text{Rate of net energy transfer by heat, work, and mass}} = \underbrace{\dot{\Delta E}_{\text{system}}}_{\text{Rate of change in internal, kinetic, potential, etc. energies}} \stackrel{\text{no (steady)}}{=} 0$$

$$\dot{E}_{\text{in}} = \dot{E}_{\text{out}}$$

$$\dot{m}h_1 + \dot{Q}_{\text{in}} = \dot{m}h_2$$

$$\dot{Q}_{\text{in}} = \dot{m}(h_2 - h_1)$$

$$q_{\text{in}} = h_2 - h_1$$

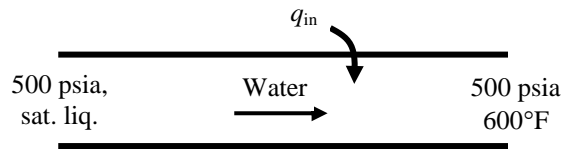

The enthalpies of water at the inlet and exit of the boiler are (Table A-5E, A-6E).

$$\left. \begin{array}{l} P_1 = 500 \text{ psia} \\ x = 0 \end{array} \right\} h_1 \cong h_f @ 500 \text{ psia} = 449.51 \text{ Btu/lbm}$$

$$\left. \begin{array}{l} P_2 = 500 \text{ psia} \\ T_2 = 600^\circ\text{F} \end{array} \right\} h_2 = 1298.6 \text{ Btu/lbm}$$

Substituting,

$$q_{\text{in}} = 1298.6 - 449.51 = \mathbf{849.1 \text{ Btu/lbm}}$$

5-90 Air at a specified rate is heated by an electrical heater. The current is to be determined.

Assumptions 1 This is a steady-flow process since there is no change with time. **2** Kinetic and potential energy changes are negligible. **3** The heat losses from the air is negligible.

Properties The gas constant of air is $0.287 \text{ kPa}\cdot\text{m}^3/\text{kg}\cdot\text{K}$ (Table A-1). The constant pressure specific heat of air at room temperature is $c_p = 1.005 \text{ kJ}/\text{kg}\cdot^\circ\text{C}$ (Table A-2a).

Analysis We take the pipe in which the air is heated as the system, which is a control volume. The energy balance for this steady-flow system can be expressed in the rate form as

$$\underbrace{\dot{E}_{\text{in}} - \dot{E}_{\text{out}}}_{\substack{\text{Rate of net energy transfer} \\ \text{by heat, work, and mass}}} = \underbrace{\Delta \dot{E}_{\text{system}}}_{\substack{\text{Rate of change in internal, kinetic,} \\ \text{potential, etc. energies}}} \stackrel{\text{no (steady)}}{=} 0$$

$$\dot{E}_{\text{in}} = \dot{E}_{\text{out}}$$

$$\dot{m}h_1 + \dot{W}_{\text{e,in}} = \dot{m}h_2$$

$$\dot{W}_{\text{e,in}} = \dot{m}(h_2 - h_1)$$

$$\mathbf{VI} = \dot{m}c_p(T_2 - T_1)$$

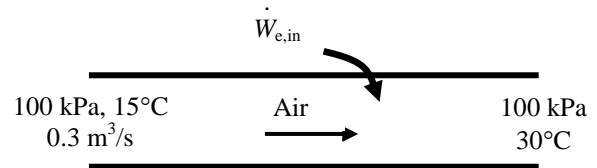

The inlet specific volume and the mass flow rate of air are

$$\nu_1 = \frac{RT_1}{P_1} = \frac{(0.287 \text{ kPa}\cdot\text{m}^3/\text{kg}\cdot\text{K})(288 \text{ K})}{100 \text{ kPa}} = 0.8266 \text{ m}^3/\text{kg}$$

$$\dot{m} = \frac{\dot{V}_1}{\nu_1} = \frac{0.3 \text{ m}^3/\text{s}}{0.8266 \text{ m}^3/\text{kg}} = 0.3629 \text{ kg/s}$$

Substituting into the energy balance equation and solving for the current gives

$$I = \frac{\dot{m}c_p(T_2 - T_1)}{\mathbf{V}} = \frac{(0.3629 \text{ kg/s})(1.005 \text{ kJ}/\text{kg}\cdot\text{K})(30 - 15)\text{K}}{110 \text{ V}} \left(\frac{1000 \text{ V}}{1 \text{ kJ/s}} \right) = \mathbf{49.7 \text{ Amperes}}$$

5-91E The cooling fan of a computer draws air, which is heated in the computer by absorbing the heat of PC circuits. The electrical power dissipated by the circuits is to be determined.

Assumptions 1 This is a steady-flow process since there is no change with time. **2** Kinetic and potential energy changes are negligible. **3** All the heat dissipated by the circuits are picked up by the air drawn by the fan.

Properties The gas constant of air is $0.3704 \text{ psia} \cdot \text{ft}^3/\text{lbm} \cdot \text{R}$ (Table A-1E). The constant pressure specific heat of air at room temperature is $c_p = 0.240 \text{ Btu}/\text{lbm} \cdot ^\circ\text{F}$ (Table A-2Ea).

Analysis We take the pipe in which the air is heated as the system, which is a control volume. The energy balance for this steady-flow system can be expressed in the rate form as

$$\underbrace{\dot{E}_{\text{in}} - \dot{E}_{\text{out}}}_{\text{Rate of net energy transfer by heat, work, and mass}} = \underbrace{\Delta \dot{E}_{\text{system}}}_{\text{Rate of change in internal, kinetic, potential, etc. energies}} \stackrel{\text{no (steady)}}{=} 0$$

$$\dot{E}_{\text{in}} = \dot{E}_{\text{out}}$$

$$\dot{m}h_1 + \dot{W}_{e,\text{in}} = \dot{m}h_2$$

$$\dot{W}_{e,\text{in}} = \dot{m}(h_2 - h_1)$$

$$\dot{W}_{e,\text{in}} = \dot{m}c_p(T_2 - T_1)$$

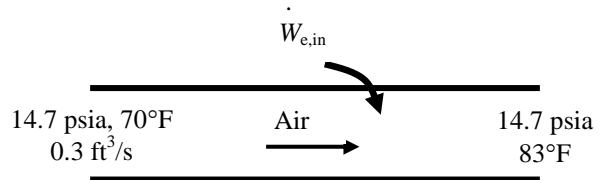

The inlet specific volume and the mass flow rate of air are

$$v_1 = \frac{RT_1}{P_1} = \frac{(0.3704 \text{ psia} \cdot \text{ft}^3/\text{lbm} \cdot \text{R})(530 \text{ R})}{14.7 \text{ psia}} = 13.35 \text{ ft}^3/\text{lbm}$$

$$\dot{m} = \frac{\dot{V}_1}{v_1} = \frac{0.3 \text{ ft}^3/\text{s}}{13.35 \text{ ft}^3/\text{lbm}} = 0.02246 \text{ lbm/s}$$

Substituting,

$$\dot{W}_{e,\text{out}} = (0.02246 \text{ lbm/s})(0.240 \text{ Btu}/\text{lbm} \cdot \text{R})(83 - 70) \text{ Btu}/\text{lbm} \left(\frac{1 \text{ kW}}{0.94782 \text{ Btu/s}} \right) = \mathbf{0.0740 \text{ kW}}$$

5-92E Electronic devices mounted on a cold plate are cooled by water. The amount of heat generated by the electronic devices is to be determined.

Assumptions 1 Steady operating conditions exist. 2 About 15 percent of the heat generated is dissipated from the components to the surroundings by convection and radiation. 3 Kinetic and potential energy changes are negligible.

Properties The properties of water at room temperature are $\rho = 62.1 \text{ lbm/ft}^3$ and $c_p = 1.00 \text{ Btu/lbm}\cdot^\circ\text{F}$ (Table A-3E).

Analysis We take the tubes of the cold plate to be the system, which is a control volume. The energy balance for this steady-flow system can be expressed in the rate form as

$$\underbrace{\dot{E}_{\text{in}} - \dot{E}_{\text{out}}}_{\text{Rate of net energy transfer by heat, work, and mass}} = \underbrace{\Delta \dot{E}_{\text{system}}}_{\text{Rate of change in internal, kinetic, potential, etc. energies}} \stackrel{\text{no (steady)}}{=} 0$$

$$\dot{E}_{\text{in}} = \dot{E}_{\text{out}}$$

$$\dot{Q}_{\text{in}} + \dot{m}h_1 = \dot{m}h_2 \quad (\text{since } \Delta \text{ke} \cong \Delta \text{pe} \cong 0)$$

$$\dot{Q}_{\text{in}} = \dot{m}c_p(T_2 - T_1)$$

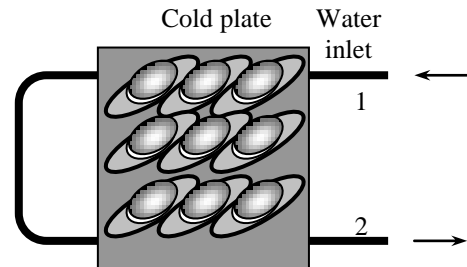

Then mass flow rate of water and the rate of heat removal by the water are determined to be

$$\dot{m} = \rho AV = \rho \frac{\pi D^2}{4} V = (62.1 \text{ lbm/ft}^3) \frac{\pi (0.25/12 \text{ ft})^2}{4} (40 \text{ ft/min}) = 0.8483 \text{ lbm/min} = 50.9 \text{ lbm/h}$$

$$\dot{Q} = \dot{m}c_p(T_{\text{out}} - T_{\text{in}}) = (50.9 \text{ lbm/h})(1.00 \text{ Btu/lbm}\cdot^\circ\text{F})(105 - 70)^\circ\text{F} = 1781 \text{ Btu/h}$$

which is 85 percent of the heat generated by the electronic devices. Then the total amount of heat generated by the electronic devices becomes

$$\dot{Q} = \frac{1781 \text{ Btu/h}}{0.85} = \mathbf{2096 \text{ Btu/h} = 614 \text{ W}}$$

5-93 A sealed electronic box is to be cooled by tap water flowing through channels on two of its sides. The mass flow rate of water and the amount of water used per year are to be determined.

Assumptions 1 Steady operating conditions exist. 2 Entire heat generated is dissipated by water. 3 Water is an incompressible substance with constant specific heats at room temperature. 4 Kinetic and potential energy changes are negligible.

Properties The specific heat of water at room temperature is $c_p = 4.18 \text{ kJ/kg} \cdot ^\circ\text{C}$ (Table A-3).

Analysis We take the water channels on the sides to be the system, which is a control volume. The energy balance for this steady-flow system can be expressed in the rate form as

$$\underbrace{\dot{E}_{\text{in}} - \dot{E}_{\text{out}}}_{\text{Rate of net energy transfer by heat, work, and mass}} = \underbrace{\Delta \dot{E}_{\text{system}}}_{\text{Rate of change in internal, kinetic, potential, etc. energies}} \stackrel{\text{no (steady)}}{=} 0$$

$$\dot{E}_{\text{in}} = \dot{E}_{\text{out}}$$

$$\dot{Q}_{\text{in}} + \dot{m}h_1 = \dot{m}h_2 \quad (\text{since } \Delta \text{ke} \cong \Delta \text{pe} \cong 0)$$

$$\dot{Q}_{\text{in}} = \dot{m}c_p(T_2 - T_1)$$

Then the mass flow rate of tap water flowing through the electronic box becomes

$$\dot{Q} = \dot{m}c_p \Delta T \longrightarrow \dot{m} = \frac{\dot{Q}}{c_p \Delta T} = \frac{2 \text{ kJ/s}}{(4.18 \text{ kJ/kg} \cdot ^\circ\text{C})(4^\circ\text{C})} = \mathbf{0.1196 \text{ kg/s}}$$

Therefore, 0.1196 kg of water is needed per second to cool this electronic box. Then the amount of cooling water used per year becomes

$$m = \dot{m}\Delta t = (0.1196 \text{ kg/s})(365 \text{ days/yr} \times 24 \text{ h/day} \times 3600 \text{ s/h}) = 3,772,000 \text{ kg/yr} = \mathbf{3,772 \text{ tons/yr}}$$

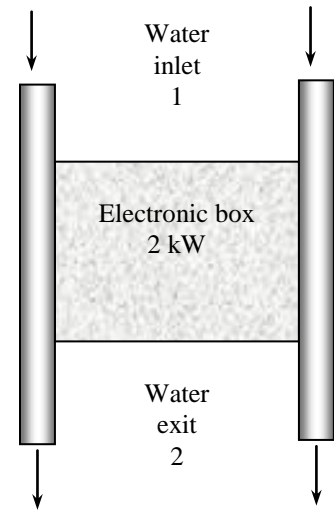

5-94 A sealed electronic box is to be cooled by tap water flowing through channels on two of its sides. The mass flow rate of water and the amount of water used per year are to be determined.

Assumptions 1 Steady operating conditions exist. 2 Entire heat generated is dissipated by water. 3 Water is an incompressible substance with constant specific heats at room temperature. 4 Kinetic and potential energy changes are negligible

Properties The specific heat of water at room temperature is $c_p = 4.18 \text{ kJ/kg} \cdot ^\circ\text{C}$ (Table A-3).

Analysis We take the water channels on the sides to be the system, which is a control volume. The energy balance for this steady-flow system can be expressed in the rate form as

$$\underbrace{\dot{E}_{\text{in}} - \dot{E}_{\text{out}}}_{\text{Rate of net energy transfer by heat, work, and mass}} = \underbrace{\Delta \dot{E}_{\text{system}}}_{\text{Rate of change in internal, kinetic, potential, etc. energies}} \stackrel{\text{no (steady)}}{=} 0$$

$$\dot{E}_{\text{in}} = \dot{E}_{\text{out}}$$

$$\dot{Q}_{\text{in}} + \dot{m}h_1 = \dot{m}h_2 \quad (\text{since } \Delta \text{ke} \cong \Delta \text{pe} \cong 0)$$

$$\dot{Q}_{\text{in}} = \dot{m}c_p(T_2 - T_1)$$

Then the mass flow rate of tap water flowing through the electronic box becomes

$$\dot{Q} = \dot{m}c_p \Delta T \longrightarrow \dot{m} = \frac{\dot{Q}}{c_p \Delta T} = \frac{4 \text{ kJ/s}}{(4.18 \text{ kJ/kg} \cdot ^\circ\text{C})(4^\circ\text{C})} = \mathbf{0.2392 \text{ kg/s}}$$

Therefore, 0.2392 kg of water is needed per second to cool this electronic box. Then the amount of cooling water used per year becomes

$$m = \dot{m}\Delta t = (0.23923 \text{ kg/s})(365 \text{ days/yr} \times 24 \text{ h/day} \times 3600 \text{ s/h}) = 7,544,400 \text{ kg/yr} = \mathbf{7544 \text{ tons/yr}}$$

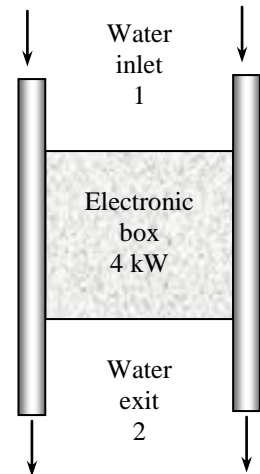

5-95  The components of an electronic device located in a horizontal duct of rectangular cross section are cooled by forced air. The heat transfer from the outer surfaces of the duct is to be determined.

Assumptions **1** Steady operating conditions exist. **2** Air is an ideal gas with constant specific heats at room temperature. **3** Kinetic and potential energy changes are negligible

Properties The gas constant of air is $R = 0.287 \text{ kJ/kg}\cdot^\circ\text{C}$ (Table A-1). The specific heat of air at room temperature is $c_p = 1.005 \text{ kJ/kg}\cdot^\circ\text{C}$ (Table A-2).

Analysis The density of air entering the duct and the mass flow rate are

$$\rho = \frac{P}{RT} = \frac{101.325 \text{ kPa}}{(0.287 \text{ kPa}\cdot\text{m}^3/\text{kg}\cdot\text{K})(30 + 273)\text{K}} = 1.165 \text{ kg/m}^3$$

$$\dot{m} = \rho\dot{V} = (1.165 \text{ kg/m}^3)(0.6 \text{ m}^3/\text{min}) = 0.700 \text{ kg/min}$$

We take the channel, excluding the electronic components, to be the system, which is a control volume. The energy balance for this steady-flow system can be expressed in the rate form as

$$\underbrace{\dot{E}_{\text{in}} - \dot{E}_{\text{out}}}_{\text{Rate of net energy transfer by heat, work, and mass}} = \underbrace{\Delta\dot{E}_{\text{system}}}_{\text{Rate of change in internal, kinetic, potential, etc. energies}} \stackrel{\text{no (steady)}}{=} 0$$

$$\dot{E}_{\text{in}} = \dot{E}_{\text{out}}$$

$$\dot{Q}_{\text{in}} + \dot{m}h_1 = \dot{m}h_2 \quad (\text{since } \Delta ke \cong \Delta pe \cong 0)$$

$$\dot{Q}_{\text{in}} = \dot{m}c_p(T_2 - T_1)$$

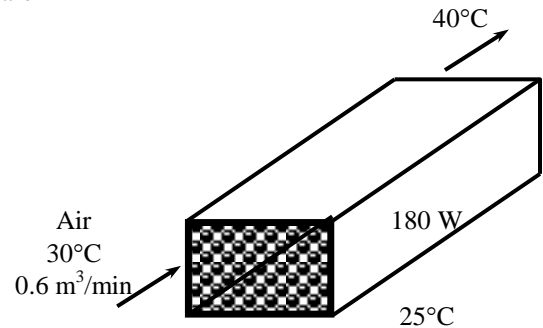

Then the rate of heat transfer to the air passing through the duct becomes

$$\dot{Q}_{\text{air}} = [\dot{m}c_p(T_{\text{out}} - T_{\text{in}})]_{\text{air}} = (0.700/60 \text{ kg/s})(1.005 \text{ kJ/kg}\cdot^\circ\text{C})(40 - 30)^\circ\text{C} = 0.117 \text{ kW} = 117 \text{ W}$$

The rest of the 180 W heat generated must be dissipated through the outer surfaces of the duct by natural convection and radiation,

$$\dot{Q}_{\text{external}} = \dot{Q}_{\text{total}} - \dot{Q}_{\text{internal}} = 180 - 117 = \mathbf{63 \text{ W}}$$

5-96 The components of an electronic device located in a horizontal duct of circular cross section is cooled by forced air. The heat transfer from the outer surfaces of the duct is to be determined.

Assumptions 1 Steady operating conditions exist. **2** Air is an ideal gas with constant specific heats at room temperature. **3** Kinetic and potential energy changes are negligible

Properties The gas constant of air is $R = 0.287 \text{ kJ/kg}\cdot^\circ\text{C}$ (Table A-1). The specific heat of air at room temperature is $c_p = 1.005 \text{ kJ/kg}\cdot^\circ\text{C}$ (Table A-2).

Analysis The density of air entering the duct and the mass flow rate are

$$\rho = \frac{P}{RT} = \frac{101.325 \text{ kPa}}{(0.287 \text{ kPa}\cdot\text{m}^3/\text{kg}\cdot\text{K})(30 + 273)\text{K}} = 1.165 \text{ kg/m}^3$$

$$\dot{m} = \rho \dot{V} = (1.165 \text{ kg/m}^3)(0.6 \text{ m}^3 / \text{min}) = 0.700 \text{ kg/min}$$

We take the channel, excluding the electronic components, to be the system, which is a control volume. The energy balance for this steady-flow system can be expressed in the rate form as

$$\underbrace{\dot{E}_{\text{in}} - \dot{E}_{\text{out}}}_{\text{Rate of net energy transfer by heat, work, and mass}} = \underbrace{\Delta \dot{E}_{\text{system}}}_{\text{Rate of change in internal, kinetic, potential, etc. energies}} \stackrel{\text{no (steady)}}{=} 0$$

$$\dot{E}_{\text{in}} = \dot{E}_{\text{out}}$$

$$\dot{Q}_{\text{in}} + \dot{m}h_1 = \dot{m}h_2 \quad (\text{since } \Delta ke \cong \Delta pe \cong 0)$$

$$\dot{Q}_{\text{in}} = \dot{m}c_p(T_2 - T_1)$$

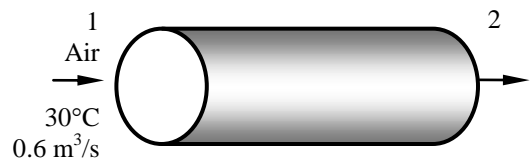

Then the rate of heat transfer to the air passing through the duct becomes

$$\dot{Q}_{\text{air}} = [\dot{m}c_p(T_{\text{out}} - T_{\text{in}})]_{\text{air}} = (0.700/60 \text{ kg/s})(1.005 \text{ kJ/kg}\cdot^\circ\text{C})(40 - 30)^\circ\text{C} = 0.117 \text{ kW} = 117 \text{ W}$$

The rest of the 180 W heat generated must be dissipated through the outer surfaces of the duct by natural convection and radiation,

$$\dot{Q}_{\text{external}} = \dot{Q}_{\text{total}} - \dot{Q}_{\text{internal}} = 180 - 117 = \mathbf{63 \text{ W}}$$

5-97 Air enters a hollow-core printed circuit board. The exit temperature of the air is to be determined.

Assumptions 1 Steady operating conditions exist. 2 Air is an ideal gas with constant specific heats at room temperature. 3 The local atmospheric pressure is 1 atm. 4 Kinetic and potential energy changes are negligible.

Properties The gas constant of air is $R = 0.287$ kJ/kg·°C (Table A-1). The specific heat of air at room temperature is $c_p = 1.005$ kJ/kg·°C (Table A-2).

Analysis The density of air entering the duct and the mass flow rate are

$$\rho = \frac{P}{RT} = \frac{101.325 \text{ kPa}}{(0.287 \text{ kPa}\cdot\text{m}^3/\text{kg}\cdot\text{K})(25 + 273)\text{K}} = 1.185 \text{ kg/m}^3$$

$$\dot{m} = \rho \dot{V} = (1.185 \text{ kg/m}^3)(0.0008 \text{ m}^3/\text{s}) = 0.0009477 \text{ kg/s}$$

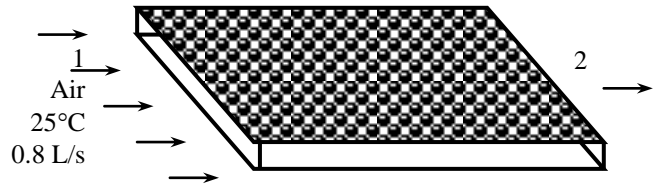

We take the hollow core to be the system, which is a control volume. The energy balance for this steady-flow system can be expressed in the rate form as

$$\underbrace{\dot{E}_{\text{in}} - \dot{E}_{\text{out}}}_{\text{Rate of net energy transfer by heat, work, and mass}} = \underbrace{\Delta \dot{E}_{\text{system}}}_{\text{Rate of change in internal, kinetic, potential, etc. energies}} \stackrel{\text{no (steady)}}{=} 0$$

$$\dot{E}_{\text{in}} = \dot{E}_{\text{out}}$$

$$\dot{Q}_{\text{in}} + \dot{m}h_1 = \dot{m}h_2 \quad (\text{since } \Delta ke \cong \Delta pe \cong 0)$$

$$\dot{Q}_{\text{in}} = \dot{m}c_p(T_2 - T_1)$$

Then the exit temperature of air leaving the hollow core becomes

$$\dot{Q}_{\text{in}} = \dot{m}c_p(T_2 - T_1) \rightarrow T_2 = T_1 + \frac{\dot{Q}_{\text{in}}}{\dot{m}c_p} = 25^\circ\text{C} + \frac{15 \text{ J/s}}{(0.0009477 \text{ kg/s})(1005 \text{ J/kg}\cdot^\circ\text{C})} = \mathbf{46.0^\circ\text{C}}$$

5-98 A computer is cooled by a fan blowing air through the case of the computer. The required flow rate of the air and the fraction of the temperature rise of air that is due to heat generated by the fan are to be determined.

Assumptions 1 Steady flow conditions exist. 2 Air is an ideal gas with constant specific heats. 3 The pressure of air is 1 atm. 4 Kinetic and potential energy changes are negligible

Properties The specific heat of air at room temperature is $c_p = 1.005 \text{ kJ/kg}\cdot^\circ\text{C}$ (Table A-2).

Analysis (a) We take the air space in the computer as the system, which is a control volume. The energy balance for this steady-flow system can be expressed in the rate form as

$$\underbrace{\dot{E}_{\text{in}} - \dot{E}_{\text{out}}}_{\text{Rate of net energy transfer by heat, work, and mass}} = \underbrace{\Delta \dot{E}_{\text{system}}}_{\text{Rate of change in internal, kinetic, potential, etc. energies}} \stackrel{\text{no (steady)}}{=} 0$$

$$\dot{E}_{\text{in}} = \dot{E}_{\text{out}}$$

$$\dot{Q}_{\text{in}} + \dot{W}_{\text{in}} + \dot{m}h_1 = \dot{m}h_2 \quad (\text{since } \Delta ke \cong \Delta pe \cong 0)$$

$$\dot{Q}_{\text{in}} + \dot{W}_{\text{in}} = \dot{m}c_p(T_2 - T_1)$$

Noting that the fan power is 25 W and the 8 PCBs transfer a total of 80 W of heat to air, the mass flow rate of air is determined to be

$$\dot{Q}_{\text{in}} + \dot{W}_{\text{in}} = \dot{m}c_p(T_e - T_i) \rightarrow \dot{m} = \frac{\dot{Q}_{\text{in}} + \dot{W}_{\text{in}}}{c_p(T_e - T_i)} = \frac{(8 \times 10) \text{ W} + 25 \text{ W}}{(1005 \text{ J/kg}\cdot^\circ\text{C})(10^\circ\text{C})} = \mathbf{0.0104 \text{ kg/s}}$$



(b) The fraction of temperature rise of air that is due to the heat generated by the fan and its motor can be determined from

$$\dot{Q} = \dot{m}c_p \Delta T \rightarrow \Delta T = \frac{\dot{Q}}{\dot{m}c_p} = \frac{25 \text{ W}}{(0.0104 \text{ kg/s})(1005 \text{ J/kg}\cdot^\circ\text{C})} = 2.4^\circ\text{C}$$

$$f = \frac{2.4^\circ\text{C}}{10^\circ\text{C}} = 0.24 = \mathbf{24\%}$$

5-99 A room is to be heated by an electric resistance heater placed in a duct in the room. The power rating of the electric heater and the temperature rise of air as it passes through the heater are to be determined.

Assumptions 1 Steady operating conditions exist. 2 Air is an ideal gas with constant specific heats at room temperature. 3 Kinetic and potential energy changes are negligible. 4 The heating duct is adiabatic, and thus heat transfer through it is negligible. 5 No air leaks in and out of the room.

Properties The gas constant of air is $0.287 \text{ kPa}\cdot\text{m}^3/\text{kg}\cdot\text{K}$ (Table A-1). The specific heats of air at room temperature are $c_p = 1.005$ and $c_v = 0.718 \text{ kJ/kg}\cdot\text{K}$ (Table A-2).

Analysis (a) The total mass of air in the room is

$$\mathcal{V} = 4 \times 5 \times 6 \text{ m}^3 = 120 \text{ m}^3$$

$$m = \frac{P_1 \mathcal{V}}{RT_1} = \frac{(98 \text{ kPa})(120 \text{ m}^3)}{(0.287 \text{ kPa}\cdot\text{m}^3/\text{kg}\cdot\text{K})(288 \text{ K})} = 142.3 \text{ kg}$$

We first take the *entire room* as our system, which is a closed system since no mass leaks in or out. The power rating of the electric heater is determined by applying the conservation of energy relation to this constant volume closed system:

$$\underbrace{E_{in} - E_{out}}_{\substack{\text{Net energy transfer} \\ \text{by heat, work, and mass}}} = \underbrace{\Delta E_{system}}_{\substack{\text{Change in internal, kinetic,} \\ \text{potential, etc. energies}}}$$

$$W_{e,in} + W_{fan,in} - Q_{out} = \Delta U \quad (\text{since } \Delta KE = \Delta PE = 0)$$

$$\Delta t (\dot{W}_{e,in} + \dot{W}_{fan,in} - \dot{Q}_{out}) = mc_{v,avg}(T_2 - T_1)$$

Solving for the electrical work input gives

$$\dot{W}_{e,in} = \dot{Q}_{out} - \dot{W}_{fan,in} + mc_v(T_2 - T_1) / \Delta t$$

$$= (150/60 \text{ kJ/s}) - (0.2 \text{ kJ/s}) + (142.3 \text{ kg})(0.718 \text{ kJ/kg}\cdot^\circ\text{C})(25 - 15)^\circ\text{C} / (20 \times 60 \text{ s})$$

$$= \mathbf{3.151 \text{ kW}}$$

(b) We now take the *heating duct* as the system, which is a control volume since mass crosses the boundary. There is only one inlet and one exit, and thus $\dot{m}_1 = \dot{m}_2 = \dot{m}$. The energy balance for this adiabatic steady-flow system can be expressed in the rate form as

$$\underbrace{\dot{E}_{in} - \dot{E}_{out}}_{\substack{\text{Rate of net energy transfer} \\ \text{by heat, work, and mass}}} = \underbrace{\Delta \dot{E}_{system}}_{\substack{\text{Rate of change in internal, kinetic,} \\ \text{potential, etc. energies}}} \stackrel{\text{no (steady)}}{=} 0$$

$$\dot{E}_{in} = \dot{E}_{out}$$

$$\dot{W}_{e,in} + \dot{W}_{fan,in} + \dot{m}h_1 = \dot{m}h_2 \quad (\text{since } \dot{Q} = \Delta ke \cong \Delta pe \cong 0)$$

$$\dot{W}_{e,in} + \dot{W}_{fan,in} = \dot{m}(h_2 - h_1) = \dot{m}c_p(T_2 - T_1)$$

Thus,

$$\Delta T = T_2 - T_1 = \frac{\dot{W}_{e,in} + \dot{W}_{fan,in}}{\dot{m}c_p} = \frac{(3.151 + 0.2) \text{ kJ/s}}{(40/60 \text{ kg/s})(1.005 \text{ kJ/kg}\cdot\text{K})} = \mathbf{5.0^\circ\text{C}}$$

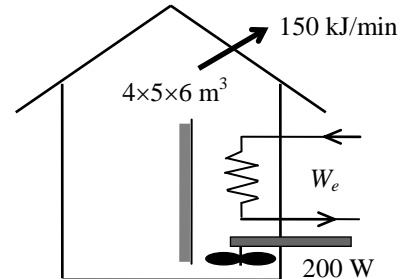

5-100 A long roll of large 1-Mn manganese steel plate is to be quenched in an oil bath at a specified rate. The rate at which heat needs to be removed from the oil to keep its temperature constant is to be determined.

Assumptions **1** Steady operating conditions exist. **2** The thermal properties of the roll are constant. **3** Kinetic and potential energy changes are negligible

Properties The properties of the steel plate are given to be $\rho = 7854 \text{ kg/m}^3$ and $c_p = 0.434 \text{ kJ/kg}\cdot^\circ\text{C}$.

Analysis The mass flow rate of the sheet metal through the oil bath is

$$\dot{m} = \rho \dot{V} = \rho w t V = (7854 \text{ kg/m}^3)(2 \text{ m})(0.005 \text{ m})(10 \text{ m/min}) = 785.4 \text{ kg/min}$$

We take the volume occupied by the sheet metal in the oil bath to be the system, which is a control volume. The energy balance for this steady-flow system can be expressed in the rate form as

$$\underbrace{\dot{E}_{\text{in}} - \dot{E}_{\text{out}}}_{\text{Rate of net energy transfer by heat, work, and mass}} = \underbrace{\Delta \dot{E}_{\text{system}}}_{\text{Rate of change in internal, kinetic, potential, etc. energies}} \stackrel{\text{no (steady)}}{=} 0$$

$$\dot{E}_{\text{in}} = \dot{E}_{\text{out}}$$

$$\dot{m} h_1 = \dot{Q}_{\text{out}} + \dot{m} h_2 \quad (\text{since } \Delta \text{ke} \cong \Delta \text{pe} \cong 0)$$

$$\dot{Q}_{\text{out}} = \dot{m} c_p (T_1 - T_2)$$

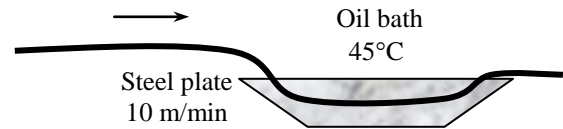

Then the rate of heat transfer from the sheet metal to the oil bath becomes

$$\dot{Q}_{\text{out}} = \dot{m} c_p (T_{\text{in}} - T_{\text{out}})_{\text{metal}} = (785.4 \text{ kg/min})(0.434 \text{ kJ/kg}\cdot^\circ\text{C})(820 - 51.1)^\circ\text{C} = 262,090 \text{ kJ/min} = \mathbf{4368 \text{ kW}}$$

This is the rate of heat transfer from the metal sheet to the oil, which is equal to the rate of heat removal from the oil since the oil temperature is maintained constant.



5-101 Problem 5-100 is reconsidered. The effect of the moving velocity of the steel plate on the rate of heat transfer from the oil bath as the velocity varies from 5 to 50 m/min is to be investigated. Rate of heat transfer is to be plotted against the plate velocity.

Analysis The problem is solved using EES, and the solution is given below.

"Knowns"

Vel = 10 [m/min]
 T_bath = 45 [C]
 T_1 = 820 [C]
 T_2 = 51.1 [C]
 rho = 785 [kg/m^3]
 C_P = 0.434 [kJ/kg-C]
 width = 2 [m]
 thick = 0.5 [cm]

"Analysis:

The mass flow rate of the sheet metal through the oil bath is:"

Vol_dot = width*thick*convert(cm,m)*Vel/convert(min,s)
 m_dot = rho*Vol_dot

"We take the volume occupied by the sheet metal in the oil bath to be the system, which is a control volume. The energy balance for this steady-flow system--the metal can be expressed in the rate form as:"

E_dot_metal_in = E_dot_metal_out
 E_dot_metal_in = m_dot*h_1
 E_dot_metal_out = m_dot*h_2 + Q_dot_metal_out

h_1 = C_P*T_1
 h_2 = C_P*T_2

Q_dot_oil_out = Q_dot_metal_out

Q _{oil,out} [kW]	Vel [m/min]
218.3	5
436.6	10
654.9	15
873.2	20
1091	25
1310	30
1528	35
1746	40
1965	45
2183	50

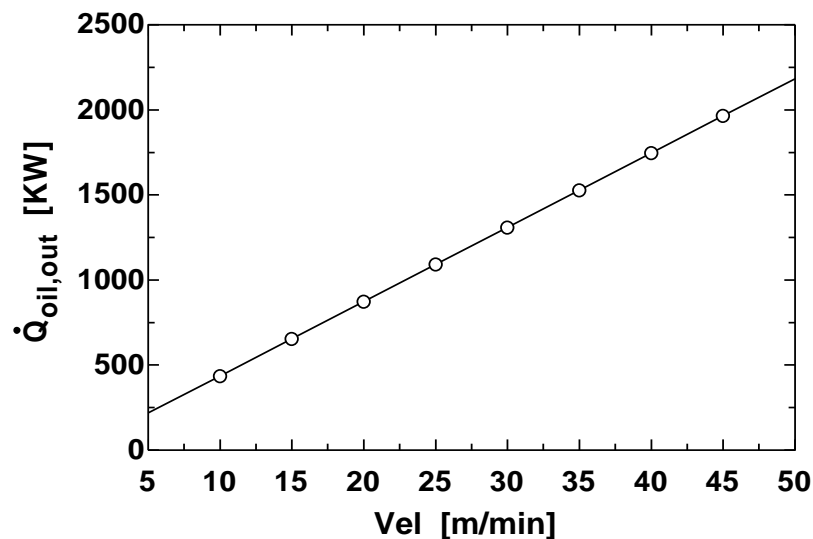

5-102E Water is heated in a parabolic solar collector. The required length of parabolic collector is to be determined.

Assumptions 1 Steady operating conditions exist. 2 Heat loss from the tube is negligible so that the entire solar energy incident on the tube is transferred to the water. 3 Kinetic and potential energy changes are negligible

Properties The specific heat of water at room temperature is $c_p = 1.00 \text{ Btu/lbm}\cdot^\circ\text{F}$ (Table A-3E).

Analysis We take the thin aluminum tube to be the system, which is a control volume. The energy balance for this steady-flow system can be expressed in the rate form as

$$\underbrace{\dot{E}_{\text{in}} - \dot{E}_{\text{out}}}_{\text{Rate of net energy transfer by heat, work, and mass}} = \underbrace{\Delta\dot{E}_{\text{system}}}_{\text{Rate of change in internal, kinetic, potential, etc. energies}} \stackrel{\text{no (steady)}}{=} 0$$

$$\dot{E}_{\text{in}} = \dot{E}_{\text{out}}$$

$$\dot{Q}_{\text{in}} + \dot{m}h_1 = \dot{m}h_2 \quad (\text{since } \Delta ke \cong \Delta pe \cong 0)$$

$$\dot{Q}_{\text{in}} = \dot{m}_{\text{water}}c_p(T_2 - T_1)$$

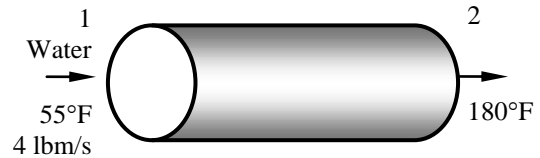

Then the total rate of heat transfer to the water flowing through the tube becomes

$$\dot{Q}_{\text{total}} = \dot{m}c_p(T_e - T_i) = (4 \text{ lbm/s})(1.00 \text{ Btu/lbm}\cdot^\circ\text{F})(180 - 55)^\circ\text{F} = 500 \text{ Btu/s} = 1,800,000 \text{ Btu/h}$$

The length of the tube required is

$$L = \frac{\dot{Q}_{\text{total}}}{\dot{Q}} = \frac{1,800,000 \text{ Btu/h}}{400 \text{ Btu/h}\cdot\text{ft}} = \mathbf{4500 \text{ ft}}$$

5-103 A house is heated by an electric resistance heater placed in a duct. The power rating of the electric heater is to be determined.

Assumptions 1 This is a steady-flow process since there is no change with time. 2 Air is an ideal gas with constant specific heats at room temperature. 3 Kinetic and potential energy changes are negligible.

Properties The constant pressure specific heat of air at room temperature is $c_p = 1.005 \text{ kJ/kg}\cdot\text{K}$ (Table A-2)

Analysis We take the *heating duct* as the system, which is a control volume since mass crosses the boundary. There is only one inlet and one exit, and thus $\dot{m}_1 = \dot{m}_2 = \dot{m}$. The energy balance for this steady-flow system can be expressed in the rate form as

$$\underbrace{\dot{E}_{\text{in}} - \dot{E}_{\text{out}}}_{\text{Rate of net energy transfer by heat, work, and mass}} = \underbrace{\Delta\dot{E}_{\text{system}}}_{\text{Rate of change in internal, kinetic, potential, etc. energies}} \stackrel{\text{no (steady)}}{=} 0$$

$$\dot{E}_{\text{in}} = \dot{E}_{\text{out}}$$

$$\dot{W}_{e,\text{in}} + \dot{W}_{\text{fan},\text{in}} + \dot{m}h_1 = \dot{Q}_{\text{out}} + \dot{m}h_2 \quad (\text{since } \Delta ke \cong \Delta pe \cong 0)$$

$$\dot{W}_{e,\text{in}} + \dot{W}_{\text{fan},\text{in}} = \dot{Q}_{\text{out}} + \dot{m}(h_2 - h_1) = \dot{Q}_{\text{out}} + \dot{m}c_p(T_2 - T_1)$$

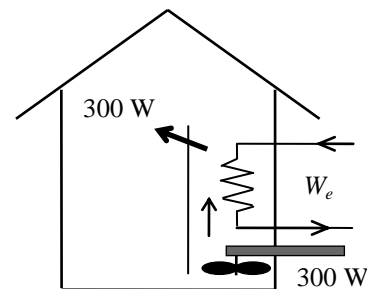

Substituting, the power rating of the heating element is determined to be

$$\dot{W}_{e,\text{in}} = \dot{Q}_{\text{out}} + \dot{m}c_p\Delta T - \dot{W}_{\text{fan},\text{in}} = (0.3 \text{ kJ/s}) + (0.6 \text{ kg/s})(1.005 \text{ kJ/kg}\cdot^\circ\text{C})(7^\circ\text{C}) - 0.3 \text{ kW} = \mathbf{4.22 \text{ kW}}$$

5-104 Steam pipes pass through an unheated area, and the temperature of steam drops as a result of heat losses. The mass flow rate of steam and the rate of heat loss from are to be determined.

Assumptions 1 This is a steady-flow process since there is no change with time. **2** Kinetic and potential energy changes are negligible. **4** There are no work interactions involved.

Properties From the steam tables (Table A-6),

$$\begin{aligned} P_1 = 2 \text{ MPa} & \left\{ \begin{array}{l} v_1 = 0.12551 \text{ m}^3/\text{kg} \\ h_1 = 3024.2 \text{ kJ/kg} \end{array} \right. \\ T_1 = 300^\circ\text{C} & \\ P_2 = 1800 \text{ kPa} & \left\{ \begin{array}{l} h_2 = 2911.7 \text{ kJ/kg} \\ T_2 = 250^\circ\text{C} \end{array} \right. \end{aligned}$$

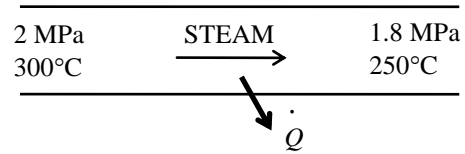

Analysis (a) The mass flow rate of steam is determined directly from

$$\dot{m} = \frac{1}{v_1} A_1 V_1 = \frac{1}{0.12551 \text{ m}^3/\text{kg}} \left[\pi (0.08 \text{ m})^2 \right] (2.5 \text{ m/s}) = \mathbf{0.4005 \text{ kg/s}}$$

(b) We take the *steam pipe* as the system, which is a control volume since mass crosses the boundary. There is only one inlet and one exit, and thus $\dot{m}_1 = \dot{m}_2 = \dot{m}$. The energy balance for this steady-flow system can be expressed in the rate form as

$$\underbrace{\dot{E}_{\text{in}} - \dot{E}_{\text{out}}}_{\text{Rate of net energy transfer by heat, work, and mass}} = \underbrace{\Delta \dot{E}_{\text{system}}}_{\text{Rate of change in internal, kinetic, potential, etc. energies}} \stackrel{\text{no (steady)}}{=} 0$$

$$\dot{E}_{\text{in}} = \dot{E}_{\text{out}}$$

$$\dot{m}h_1 = \dot{Q}_{\text{out}} + \dot{m}h_2 \quad (\text{since } \dot{W} \cong \Delta \text{ke} \cong \Delta \text{pe} \cong 0)$$

$$\dot{Q}_{\text{out}} = \dot{m}(h_1 - h_2)$$

Substituting, the rate of heat loss is determined to be

$$\dot{Q}_{\text{loss}} = (0.4005 \text{ kg/s})(3024.2 - 2911.7) \text{ kJ/kg} = \mathbf{45.1 \text{ kJ/s}}$$

5-105 R-134a is condensed in a condenser. The heat transfer per unit mass is to be determined.

Assumptions 1 This is a steady-flow process since there is no change with time. **2** Kinetic and potential energy changes are negligible. **3** There are no work interactions.

Analysis We take the pipe in which R-134a is condensed as the system, which is a control volume. The energy balance for this steady-flow system can be expressed in the rate form as

$$\underbrace{\dot{E}_{\text{in}} - \dot{E}_{\text{out}}}_{\text{Rate of net energy transfer by heat, work, and mass}} = \underbrace{\dot{\Delta E}_{\text{system}}}_{\text{Rate of change in internal, kinetic, potential, etc. energies}} \stackrel{\text{no (steady)}}{=} 0$$

$$\dot{E}_{\text{in}} = \dot{E}_{\text{out}}$$

$$\dot{m}h_1 = \dot{m}h_2 + \dot{Q}_{\text{out}}$$

$$\dot{Q}_{\text{out}} = \dot{m}(h_1 - h_2)$$

$$q_{\text{out}} = h_1 - h_2$$

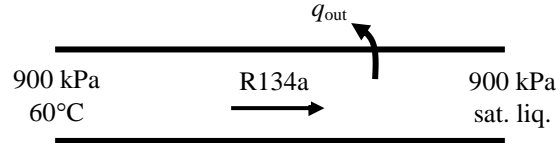

The enthalpies of R-134a at the inlet and exit of the condenser are (Table A-12, A-13).

$$\left. \begin{array}{l} P_1 = 900 \text{ kPa} \\ T_1 = 60^\circ\text{C} \end{array} \right\} h_1 = 295.15 \text{ kJ/kg}$$

$$\left. \begin{array}{l} P_2 = 900 \text{ kPa} \\ x = 0 \end{array} \right\} h_2 = h_f @ 900 \text{ kPa} = 101.62 \text{ kJ/kg}$$

Substituting,

$$q_{\text{out}} = 295.15 - 101.62 = \mathbf{193.5 \text{ kJ/kg}}$$

5-106 Water is heated at constant pressure so that it changes a state from saturated liquid to saturated vapor. The heat transfer per unit mass is to be determined.

Assumptions 1 This is a steady-flow process since there is no change with time. **2** Kinetic and potential energy changes are negligible. **3** There are no work interactions.

Analysis We take the pipe in which water is heated as the system, which is a control volume. The energy balance for this steady-flow system can be expressed in the rate form as

$$\underbrace{\dot{E}_{\text{in}} - \dot{E}_{\text{out}}}_{\text{Rate of net energy transfer by heat, work, and mass}} = \underbrace{\dot{\Delta E}_{\text{system}}}_{\text{Rate of change in internal, kinetic, potential, etc. energies}} \stackrel{\text{no (steady)}}{=} 0$$

$$\dot{E}_{\text{in}} = \dot{E}_{\text{out}}$$

$$\dot{m}h_1 + \dot{Q}_{\text{in}} = \dot{m}h_2$$

$$\dot{Q}_{\text{in}} = \dot{m}(h_2 - h_1)$$

$$q_{\text{in}} = h_2 - h_1 = h_{fg}$$

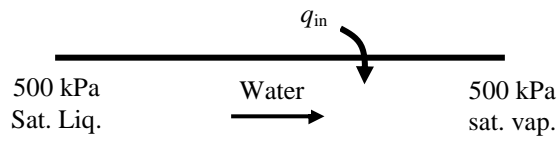

where

$$h_{fg @ 500 \text{ kPa}} = 2108.0 \text{ kJ/kg} \quad (\text{Table A-5})$$

Thus,

$$q_{\text{in}} = \mathbf{2108 \text{ kJ/kg}}$$

5-107 Water is heated by a 7-kW resistance heater as it flows through an insulated tube. The mass flow rate of water is to be determined.

Assumptions 1 This is a steady-flow process since there is no change with time. **2** Water is an incompressible substance with constant specific heats at room temperature. **3** Kinetic and potential energy changes are negligible. **4** The tube is adiabatic and thus heat losses are negligible.

Properties The specific heat of water at room temperature is $c = 4.18 \text{ kJ/kg}\cdot^\circ\text{C}$ (Table A-3).

Analysis We take the *water pipe* as the system, which is a control volume since mass crosses the boundary. There is only one inlet and one exit, and thus $\dot{m}_1 = \dot{m}_2 = \dot{m}$. The energy balance for this steady-flow system can be expressed in the rate form as

$$\underbrace{\dot{E}_{\text{in}} - \dot{E}_{\text{out}}}_{\text{Rate of net energy transfer by heat, work, and mass}} = \underbrace{\Delta \dot{E}_{\text{system}}^{\neq 0} \text{ (steady)}}_{\text{Rate of change in internal, kinetic, potential, etc. energies}} = 0$$

$$\dot{E}_{\text{in}} = \dot{E}_{\text{out}}$$

$$\dot{W}_{\text{e,in}} + \dot{m}h_1 = \dot{m}h_2 \quad (\text{since } \dot{Q}_{\text{out}} \cong \Delta ke \cong \Delta pe \cong 0)$$

$$\dot{W}_{\text{e,in}} = \dot{m}(h_2 - h_1) = \dot{m}[c(T_2 - T_1) + v\Delta P^{\neq 0}] = \dot{m}c(T_2 - T_1)$$

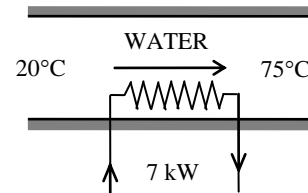

Substituting, the mass flow rates of water is determined to be

$$\dot{m} = \frac{\dot{W}_{\text{e,in}}}{c(T_2 - T_1)} = \frac{7 \text{ kJ/s}}{(4.184 \text{ kJ/kg}\cdot^\circ\text{C})(75 - 20)^\circ\text{C}} = \mathbf{0.0304 \text{ kg/s}}$$

5-108 Electrical work is supplied to the air as it flows in a hair dryer. The mass flow rate of air and the volume flow rate at the exit are to be determined.

Assumptions 1 This is a steady-flow process since there is no change with time. **2** Kinetic and potential energy changes are negligible. **3** Heat loss from the dryer is negligible.

Properties The gas constant of argon is $0.287 \text{ kPa}\cdot\text{m}^3/\text{kg}\cdot\text{K}$. The constant pressure specific heat of air at room temperature is $c_p = 1.005 \text{ kJ/kg}\cdot^\circ\text{C}$ (Table A-2a).

Analysis (a) We take the pipe as the system, which is a control volume. The energy balance for this steady-flow system can be expressed in the rate form as

$$\underbrace{\dot{E}_{\text{in}} - \dot{E}_{\text{out}}}_{\substack{\text{Rate of net energy transfer} \\ \text{by heat, work, and mass}}} = \underbrace{\Delta\dot{E}_{\text{system}}}_{\substack{\text{Rate of change in internal, kinetic,} \\ \text{potential, etc. energies}}} \stackrel{\text{no (steady)}}{=} 0$$

$$\dot{E}_{\text{in}} = \dot{E}_{\text{out}}$$

$$\dot{m} \left(h_1 + \frac{V_1^2}{2} \right) + \dot{W}_{\text{in}} = \dot{m} \left(h_2 + \frac{V_2^2}{2} \right)$$

$$\dot{W}_{\text{in}} = \dot{m} \left(h_2 - h_1 + \frac{V_2^2 - V_1^2}{2} \right)$$

$$\dot{W}_{\text{in}} = \dot{m} \left(c_p (T_2 - T_1) + \frac{V_2^2 - V_1^2}{2} \right)$$

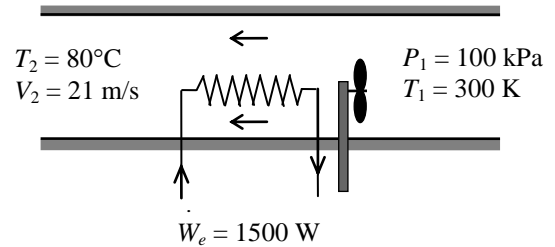

Substituting and solving for the mass flow rate,

$$\dot{m} = \frac{\dot{W}_{\text{in}}}{c_p (T_2 - T_1) + \frac{V_2^2 - V_1^2}{2}}$$

$$= \frac{1.50 \text{ kW}}{(1.005 \text{ kJ/kg}\cdot\text{K})(353 - 300)\text{K} + \frac{(21 \text{ m/s})^2 - 0}{2} \left(\frac{1 \text{ kJ/kg}}{1000 \text{ m}^2/\text{s}^2} \right)}$$

$$= \mathbf{0.0280 \text{ kg/s}}$$

(b) The exit specific volume and the volume flow rate are

$$\nu_2 = \frac{RT_2}{P_2} = \frac{(0.287 \text{ kPa}\cdot\text{m}^3/\text{kg}\cdot\text{K})(353 \text{ K})}{100 \text{ kPa}} = 1.013 \text{ m}^3/\text{kg}$$

$$\dot{V}_2 = \dot{m}\nu_2 = (0.02793 \text{ kg/s})(1.013 \text{ m}^3/\text{kg}) = \mathbf{0.0284 \text{ m}^3/\text{s}}$$



5-109 Problem 5-108 is reconsidered. The effect of the exit velocity on the mass flow rate and the exit volume flow rate is to be investigated.

Analysis The problem is solved using EES, and the solution is given below.

"Given"

T1=300 [K]
 P=100 [kPa]
 Vel_1=0 [m/s]
 W_dot_e_in=1.5 [kW]
 T2=(80+273) [K]
 Vel_2=21 [m/s]

"Properties"

c_p=1.005 [kJ/kg-K]
 R=0.287 [kJ/kg-K]

"Analysis"

W_dot_e_in=m_dot*c_p*(T2-T1)+m_dot*(Vel_2^2-Vel_1^2)*Convert(m^2/s^2,kJ/kg) "energy balance on hair dryer"

v2=(R*T2)/P

Vol_dot_2=m_dot*v2

Vel ₂ [m/s]	m [kg/s]	Vol ₂ [m ³ /s]
5	0.02815	0.02852
7.5	0.02813	0.0285
10	0.02811	0.02848
12.5	0.02808	0.02845
15	0.02804	0.02841
17.5	0.028	0.02837
20	0.02795	0.02832
22.5	0.0279	0.02826
25	0.02783	0.0282

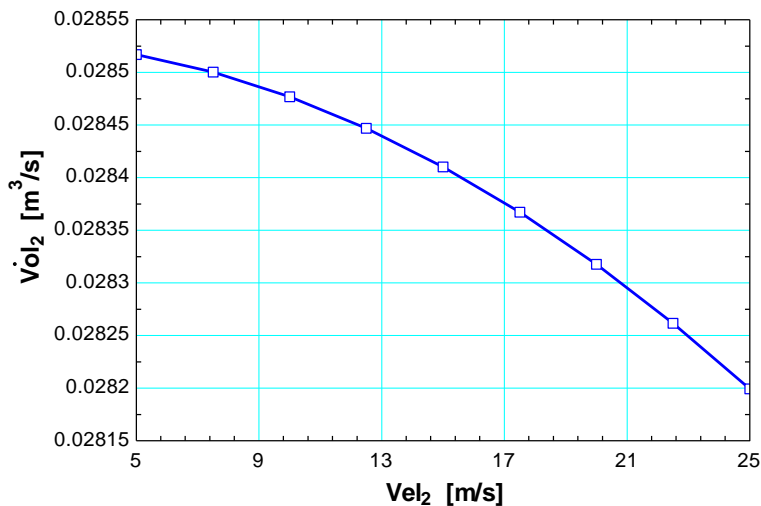
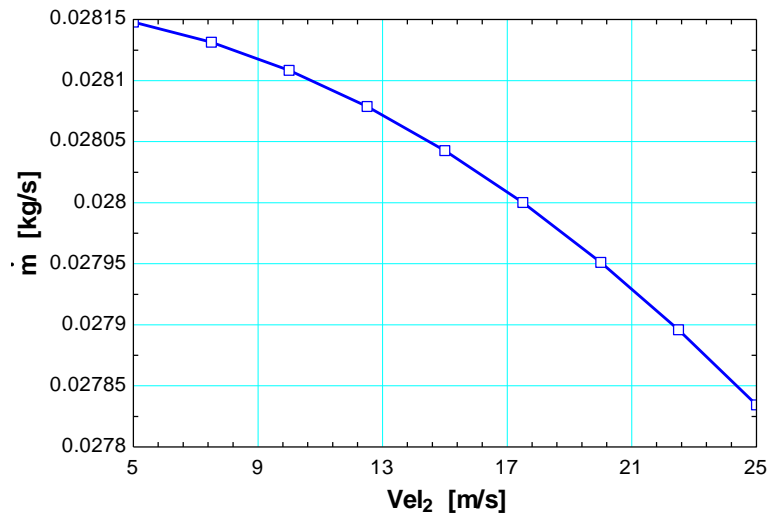

5-110E The ducts of an air-conditioning system pass through an unconditioned area. The inlet velocity and the exit temperature of air are to be determined.

Assumptions 1 This is a steady-flow process since there is no change with time. **2** Air is an ideal gas with constant specific heats at room temperature. **3** Kinetic and potential energy changes are negligible. **4** There are no work interactions involved.

Properties The gas constant of air is $0.3704 \text{ psia}\cdot\text{ft}^3/\text{lbm}\cdot\text{R}$ (Table A-1E). The constant pressure specific heat of air at room temperature is $c_p = 0.240 \text{ Btu}/\text{lbm}\cdot\text{R}$ (Table A-2E)

Analysis (a) The inlet velocity of air through the duct is

$$V_1 = \frac{\dot{V}_1}{A_1} = \frac{\dot{V}_1}{\pi r^2} = \frac{450 \text{ ft}^3/\text{min}}{\pi(5/12 \text{ ft})^2} = \mathbf{825 \text{ ft/min}}$$

Then the mass flow rate of air becomes

$$\nu_1 = \frac{RT_1}{P_1} = \frac{(0.3704 \text{ psia}\cdot\text{ft}^3/\text{lbm}\cdot\text{R})(510 \text{ R})}{(15 \text{ psia})} = 12.6 \text{ ft}^3/\text{lbm}$$

$$\dot{m} = \frac{\dot{V}_1}{\nu_1} = \frac{450 \text{ ft}^3/\text{min}}{12.6 \text{ ft}^3/\text{lbm}} = 35.7 \text{ lbm/min} = 0.595 \text{ lbm/s}$$

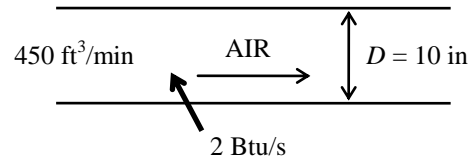

(b) We take the *air-conditioning duct* as the system, which is a control volume since mass crosses the boundary. There is only one inlet and one exit, and thus $\dot{m}_1 = \dot{m}_2 = \dot{m}$. The energy balance for this steady-flow system can be expressed in the rate form as

$$\underbrace{\dot{E}_{\text{in}} - \dot{E}_{\text{out}}}_{\text{Rate of net energy transfer by heat, work, and mass}} = \underbrace{\Delta \dot{E}_{\text{system}}}_{\text{Rate of change in internal, kinetic, potential, etc. energies}} \stackrel{\text{no (steady)}}{=} 0$$

$$\dot{E}_{\text{in}} = \dot{E}_{\text{out}}$$

$$\dot{Q}_{\text{in}} + \dot{m}h_1 = \dot{m}h_2 \quad (\text{since } \dot{W} \cong \Delta \text{ke} \cong \Delta \text{pe} \cong 0)$$

$$\dot{Q}_{\text{in}} = \dot{m}(h_2 - h_1) = \dot{m}c_p(T_2 - T_1)$$

Then the exit temperature of air becomes

$$T_2 = T_1 + \frac{\dot{Q}_{\text{in}}}{\dot{m}c_p} = 50^\circ\text{F} + \frac{2 \text{ Btu/s}}{(0.595 \text{ lbm/s})(0.24 \text{ Btu}/\text{lbm}\cdot^\circ\text{F})} = \mathbf{64.0^\circ\text{F}}$$

Charging and Discharging Processes

5-111 Steam in a supply line is allowed to enter an initially evacuated tank. The temperature of the steam in the supply line and the flow work are to be determined.

Analysis Flow work of the steam in the supply line is converted to sensible internal energy in the tank. That is,

$$h_{\text{line}} = u_{\text{tank}}$$

where

$$\left. \begin{array}{l} P_{\text{tank}} = 4 \text{ MPa} \\ T_{\text{tank}} = 550^\circ\text{C} \end{array} \right\} u_{\text{tank}} = 3189.5 \text{ kJ/kg (Table A-6)}$$

Now, the properties of steam in the line can be calculated

$$\left. \begin{array}{l} P_{\text{line}} = 4 \text{ MPa} \\ h_{\text{line}} = 3189.5 \text{ kJ/kg} \end{array} \right\} \begin{array}{l} T_{\text{line}} = \mathbf{389.5^\circ\text{C}} \\ u_{\text{line}} = 2901.5 \text{ kJ/kg} \end{array} \quad (\text{Table A-6})$$

The flow work per unit mass is the difference between enthalpy and internal energy of the steam in the line

$$w_{\text{flow}} = h_{\text{line}} - u_{\text{line}} = 3189.5 - 2901.5 = \mathbf{288 \text{ kJ/kg}}$$

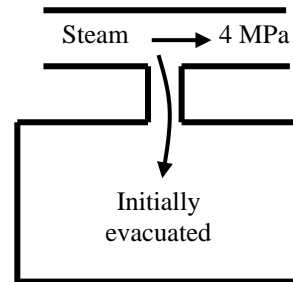

5-112 Steam flowing in a supply line is allowed to enter into an insulated tank until a specified state is achieved in the tank. The mass of the steam that has entered and the pressure of the steam in the supply line are to be determined.

Assumptions 1 This is an unsteady process since the conditions within the device are changing during the process, but it can be analyzed as a uniform-flow process since the state of fluid entering the tank remains constant. **2** Kinetic and potential energies are negligible.

Properties The initial and final properties of steam in the tank are (Tables A-5 and A-6)

$$\left. \begin{array}{l} P_1 = 1 \text{ MPa} \\ x_1 = 1 \text{ (sat. vap.)} \end{array} \right\} \begin{array}{l} \nu_1 = 0.19436 \text{ m}^3/\text{kg} \\ u_1 = 2582.8 \text{ kJ/kg} \end{array}$$

$$\left. \begin{array}{l} P_2 = 2 \text{ MPa} \\ T_2 = 300^\circ\text{C} \end{array} \right\} \begin{array}{l} \nu_2 = 0.12551 \text{ m}^3/\text{kg} \\ u_2 = 2773.2 \text{ kJ/kg} \end{array}$$

Analysis We take the tank as the system, which is a control volume since mass crosses the boundary. Noting that the microscopic energies of flowing and nonflowing fluids are represented by enthalpy h and internal energy u , respectively, the mass and energy balances for this uniform-flow system can be expressed as

$$\text{Mass balance: } m_{\text{in}} - m_{\text{out}} = \Delta m_{\text{system}} \rightarrow m_i = m_2 - m_1$$

$$\text{Energy balance: } \underbrace{E_{\text{in}} - E_{\text{out}}}_{\substack{\text{Net energy transfer} \\ \text{by heat, work, and mass}}} = \underbrace{\Delta E_{\text{system}}}_{\substack{\text{Change in internal, kinetic,} \\ \text{potential, etc. energies}}}$$

$$m_i h_i = m_2 u_2 - m_1 u_1 \quad (\text{since } Q \cong ke \cong pe \cong 0)$$

The initial and final masses and the mass that has entered are

$$m_1 = \frac{\nu}{\nu_1} = \frac{2 \text{ m}^3}{0.19436 \text{ m}^3/\text{kg}} = 10.29 \text{ kg}$$

$$m_2 = \frac{\nu}{\nu_2} = \frac{2 \text{ m}^3}{0.12551 \text{ m}^3/\text{kg}} = 15.94 \text{ kg}$$

$$m_i = m_2 - m_1 = 15.94 - 10.29 = \mathbf{5.645 \text{ kg}}$$

Substituting,

$$(5.645 \text{ kg})h_i = (15.94 \text{ kg})(2773.2 \text{ kJ/kg}) - (10.29 \text{ kg})(2582.8 \text{ kJ/kg}) \rightarrow h_i = 3120.3 \text{ kJ/kg}$$

The pressure in the supply line is

$$\left. \begin{array}{l} h_i = 3120.3 \text{ kJ/kg} \\ T_i = 400^\circ\text{C} \end{array} \right\} P_i = \mathbf{8931 \text{ kPa}} \quad (\text{determined from EES})$$

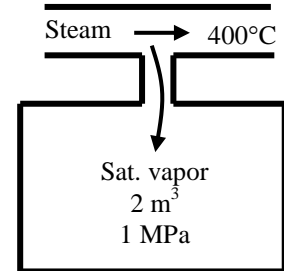

5-113 Helium flows from a supply line to an initially evacuated tank. The flow work of the helium in the supply line and the final temperature of the helium in the tank are to be determined.

Properties The properties of helium are $R = 2.0769 \text{ kJ/kg}\cdot\text{K}$, $c_p = 5.1926 \text{ kJ/kg}\cdot\text{K}$, $c_v = 3.1156 \text{ kJ/kg}\cdot\text{K}$ (Table A-2a).

Analysis The flow work is determined from its definition but we first determine the specific volume

$$v = \frac{RT_{\text{line}}}{P} = \frac{(2.0769 \text{ kJ/kg}\cdot\text{K})(120 + 273 \text{ K})}{(200 \text{ kPa})} = 4.0811 \text{ m}^3/\text{kg}$$

$$w_{\text{flow}} = Pv = (200 \text{ kPa})(4.0811 \text{ m}^3/\text{kg}) = \mathbf{816.2 \text{ kJ/kg}}$$

Noting that the flow work in the supply line is converted to sensible internal energy in the tank, the final helium temperature in the tank is determined as follows

$$u_{\text{tank}} = h_{\text{line}}$$

$$h_{\text{line}} = c_p T_{\text{line}} = (5.1926 \text{ kJ/kg}\cdot\text{K})(120 + 273 \text{ K}) = 2040.7 \text{ kJ/kg}$$

$$u_{\text{tank}} = c_v T_{\text{tank}} \longrightarrow 2040.7 \text{ kJ/kg} = (3.1156 \text{ kJ/kg}\cdot\text{K})T_{\text{tank}} \longrightarrow T_{\text{tank}} = \mathbf{655.0 \text{ K}}$$

Alternative Solution: Noting the definition of specific heat ratio, the final temperature in the tank can also be determined from

$$T_{\text{tank}} = kT_{\text{line}} = 1.667(120 + 273 \text{ K}) = \mathbf{655.1 \text{ K}}$$

which is practically the same result.

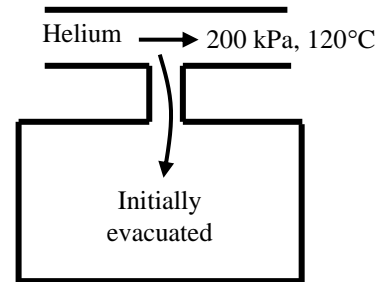

5-114 An evacuated bottle is surrounded by atmospheric air. A valve is opened, and air is allowed to fill the bottle. The amount of heat transfer through the wall of the bottle when thermal and mechanical equilibrium is established is to be determined.

Assumptions 1 This is an unsteady process since the conditions within the device are changing during the process, but it can be analyzed as a uniform-flow process since the state of fluid at the inlet remains constant. **2** Air is an ideal gas with variable specific heats. **3** Kinetic and potential energies are negligible. **4** There are no work interactions involved. **5** The direction of heat transfer is to the air in the bottle (will be verified).

Properties The gas constant of air is $0.287 \text{ kPa}\cdot\text{m}^3/\text{kg}\cdot\text{K}$ (Table A-1).

Analysis We take the bottle as the system, which is a control volume since mass crosses the boundary. Noting that the microscopic energies of flowing and nonflowing fluids are represented by enthalpy h and internal energy u , respectively, the mass and energy balances for this uniform-flow system can be expressed as

Mass balance:

$$m_{\text{in}} - m_{\text{out}} = \Delta m_{\text{system}} \rightarrow m_i = m_2 \quad (\text{since } m_{\text{out}} = m_{\text{initial}} = 0)$$

Energy balance:

$$\underbrace{E_{\text{in}} - E_{\text{out}}}_{\text{Net energy transfer by heat, work, and mass}} = \underbrace{\Delta E_{\text{system}}}_{\text{Change in internal, kinetic, potential, etc. energies}}$$

$$Q_{\text{in}} + m_i h_i = m_2 u_2 \quad (\text{since } W \cong E_{\text{out}} = E_{\text{initial}} = ke \cong pe \cong 0)$$

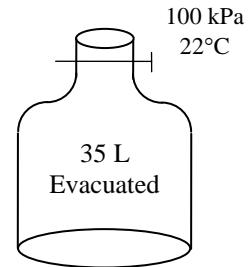

Combining the two balances:

$$Q_{\text{in}} = m_2(u_2 - h_i)$$

where

$$m_2 = \frac{P_2 V}{RT_2} = \frac{(100 \text{ kPa})(0.035 \text{ m}^3)}{(0.287 \text{ kPa}\cdot\text{m}^3/\text{kg}\cdot\text{K})(295 \text{ K})} = 0.04134 \text{ kg}$$

$$T_i = T_2 = 295 \text{ K} \xrightarrow{\text{Table A-17}} \begin{matrix} h_i = 295.17 \text{ kJ/kg} \\ u_2 = 210.49 \text{ kJ/kg} \end{matrix}$$

Substituting,

$$Q_{\text{in}} = (0.04134 \text{ kg})(210.49 - 295.17) \text{ kJ/kg} = -3.50 \text{ kJ}$$

or

$$Q_{\text{out}} = \mathbf{3.50 \text{ kJ}}$$

Discussion The negative sign for heat transfer indicates that the assumed direction is wrong. Therefore, we reverse the direction.

5-115 A rigid tank initially contains superheated steam. A valve at the top of the tank is opened, and vapor is allowed to escape at constant pressure until the temperature rises to 500°C. The amount of heat transfer is to be determined.

Assumptions 1 This is an unsteady process since the conditions within the device are changing during the process, but it can be analyzed as a uniform-flow process by using constant average properties for the steam leaving the tank. **2** Kinetic and potential energies are negligible. **3** There are no work interactions involved. **4** The direction of heat transfer is to the tank (will be verified).

Properties The properties of water are (Tables A-4 through A-6)

$$\begin{aligned} P_1 = 2 \text{ MPa} & \left\{ \begin{array}{l} v_1 = 0.12551 \text{ m}^3/\text{kg} \\ T_1 = 300^\circ\text{C} \end{array} \right. & \left. \begin{array}{l} u_1 = 2773.2 \text{ kJ/kg}, \\ h_1 = 3024.2 \text{ kJ/kg} \end{array} \right. \\ P_2 = 2 \text{ MPa} & \left\{ \begin{array}{l} v_2 = 0.17568 \text{ m}^3/\text{kg} \\ T_2 = 500^\circ\text{C} \end{array} \right. & \left. \begin{array}{l} u_2 = 3116.9 \text{ kJ/kg}, \\ h_2 = 3468.3 \text{ kJ/kg} \end{array} \right. \end{aligned}$$

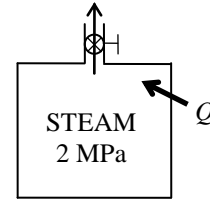

Analysis We take the tank as the system, which is a control volume since mass crosses the boundary. Noting that the microscopic energies of flowing and nonflowing fluids are represented by enthalpy h and internal energy u , respectively, the mass and energy balances for this uniform-flow system can be expressed as

Mass balance:

$$m_{\text{in}} - m_{\text{out}} = \Delta m_{\text{system}} \rightarrow m_e = m_1 - m_2$$

Energy balance:

$$\underbrace{E_{\text{in}} - E_{\text{out}}}_{\text{Net energy transfer by heat, work, and mass}} = \underbrace{\Delta E_{\text{system}}}_{\text{Change in internal, kinetic, potential, etc. energies}}$$

$$Q_{\text{in}} - m_e h_e = m_2 u_2 - m_1 u_1 \quad (\text{since } W \cong ke \cong pe \cong 0)$$

The state and thus the enthalpy of the steam leaving the tank is changing during this process. But for simplicity, we assume constant properties for the exiting steam at the average values. Thus,

$$h_e \cong \frac{h_1 + h_2}{2} = \frac{3024.2 + 3468.3 \text{ kJ/kg}}{2} = 3246.2 \text{ kJ/kg}$$

The initial and the final masses in the tank are

$$m_1 = \frac{V_1}{v_1} = \frac{0.2 \text{ m}^3}{0.12551 \text{ m}^3/\text{kg}} = 1.594 \text{ kg}$$

$$m_2 = \frac{V_2}{v_2} = \frac{0.2 \text{ m}^3}{0.17568 \text{ m}^3/\text{kg}} = 1.138 \text{ kg}$$

Then from the mass and energy balance relations,

$$m_e = m_1 - m_2 = 1.594 - 1.138 = 0.456 \text{ kg}$$

$$\begin{aligned} Q_{\text{in}} &= m_e h_e + m_2 u_2 - m_1 u_1 \\ &= (0.456 \text{ kg})(3246.2 \text{ kJ/kg}) + (1.138 \text{ kg})(3116.9 \text{ kJ/kg}) - (1.594 \text{ kg})(2773.2 \text{ kJ/kg}) \\ &= \mathbf{606.8 \text{ kJ}} \end{aligned}$$

5-116E A rigid tank initially contains saturated water vapor. The tank is connected to a supply line, and water vapor is allowed to enter the tank until one-half of the tank is filled with liquid water. The final pressure in the tank, the mass of steam that entered, and the heat transfer are to be determined.

Assumptions 1 This is an unsteady process since the conditions within the device are changing during the process, but it can be analyzed as a uniform-flow process since the state of fluid at the inlet remains constant. **2** Kinetic and potential energies are negligible. **3** There are no work interactions involved. **4** The direction of heat transfer is to the tank (will be verified).

Properties The properties of water are (Tables A-4E through A-6E)

$$\left. \begin{array}{l} T_1 = 300^\circ\text{F} \\ \text{sat. vapor} \end{array} \right\} \begin{array}{l} v_1 = v_{g@300^\circ\text{F}} = 6.4663 \text{ ft}^3/\text{lbm} \\ u_1 = u_{g@300^\circ\text{F}} = 1099.8 \text{ Btu/lbm} \end{array}$$

$$\left. \begin{array}{l} T_2 = 300^\circ\text{F} \\ \text{sat. mixture} \end{array} \right\} \begin{array}{l} v_f = 0.01745, \quad v_g = 6.4663 \text{ ft}^3/\text{lbm} \\ u_f = 269.51, \quad u_g = 1099.8 \text{ Btu/lbm} \end{array}$$

$$\left. \begin{array}{l} P_i = 200 \text{ psia} \\ T_i = 400^\circ\text{F} \end{array} \right\} h_i = 1210.9 \text{ Btu/lbm}$$

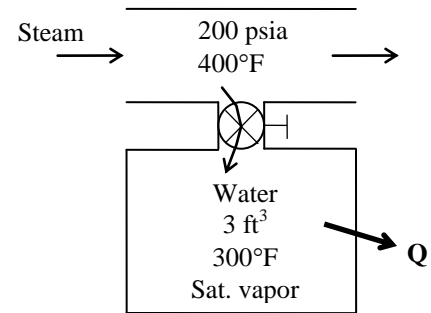

Analysis We take the tank as the system, which is a control volume since mass crosses the boundary. Noting that the microscopic energies of flowing and nonflowing fluids are represented by enthalpy h and internal energy u , respectively, the mass and energy balances for this uniform-flow system can be expressed as

$$\text{Mass balance:} \quad m_{\text{in}} - m_{\text{out}} = \Delta m_{\text{system}} \rightarrow m_i = m_2 - m_1$$

$$\text{Energy balance:} \quad \underbrace{E_{\text{in}} - E_{\text{out}}}_{\substack{\text{Net energy transfer} \\ \text{by heat, work, and mass}}} = \underbrace{\Delta E_{\text{system}}}_{\substack{\text{Change in internal, kinetic,} \\ \text{potential, etc. energies}}}$$

$$Q_{\text{in}} + m_i h_i = m_2 u_2 - m_1 u_1 \quad (\text{since } W \cong ke \cong pe \cong 0)$$

(a) The tank contains saturated mixture at the final state at 250°F, and thus the exit pressure is the saturation pressure at this temperature,

$$P_2 = P_{\text{sat}@300^\circ\text{F}} = \mathbf{67.03 \text{ psia}}$$

(b) The initial and the final masses in the tank are

$$m_1 = \frac{v}{v_1} = \frac{3 \text{ ft}^3}{6.4663 \text{ ft}^3/\text{lbm}} = 0.464 \text{ lbm}$$

$$m_2 = m_f + m_g = \frac{v_f}{v_f} + \frac{v_g}{v_g} = \frac{1.5 \text{ ft}^3}{0.01745 \text{ ft}^3/\text{lbm}} + \frac{1.5 \text{ ft}^3}{6.4663 \text{ ft}^3/\text{lbm}} = 85.97 + 0.232 = 86.20 \text{ lbm}$$

Then from the mass balance

$$m_i = m_2 - m_1 = 86.20 - 0.464 = \mathbf{85.74 \text{ lbm}}$$

(c) The heat transfer during this process is determined from the energy balance to be

$$\begin{aligned} Q_{\text{in}} &= -m_i h_i + m_2 u_2 - m_1 u_1 \\ &= -(85.74 \text{ lbm})(1210.9 \text{ Btu/lbm}) + 23,425 \text{ Btu} - (0.464 \text{ lbm})(1099.8 \text{ Btu/lbm}) \\ &= -80,900 \text{ Btu} \rightarrow Q_{\text{out}} = \mathbf{80,900 \text{ Btu}} \end{aligned}$$

since

$$U_2 = m_2 u_2 = m_f u_f + m_g u_g = 85.97 \times 269.51 + 0.232 \times 1099.8 = 23,425 \text{ Btu}$$

Discussion A negative result for heat transfer indicates that the assumed direction is wrong, and should be reversed.

5-117 A pressure cooker is initially half-filled with liquid water. If the pressure cooker is not to run out of liquid water for 1 h, the highest rate of heat transfer allowed is to be determined.

Assumptions 1 This is an unsteady process since the conditions within the device are changing during the process, but it can be analyzed as a uniform-flow process since the state of fluid leaving the device remains constant. **2** Kinetic and potential energies are negligible. **3** There are no work interactions involved.

Properties The properties of water are (Tables A-4 through A-6)

$$P_1 = 175 \text{ kPa} \rightarrow \nu_f = 0.001057 \text{ m}^3/\text{kg}, \nu_g = 1.0037 \text{ m}^3/\text{kg}$$

$$u_f = 486.82 \text{ kJ/kg}, u_g = 2524.5 \text{ kJ/kg}$$

$$P_2 = 175 \text{ kPa} \left\{ \begin{array}{l} \nu_2 = \nu_{g@175 \text{ kPa}} = 1.0036 \text{ m}^3/\text{kg} \\ \text{sat. vapor} \end{array} \right. \left. \begin{array}{l} u_2 = u_{g@175 \text{ kPa}} = 2524.5 \text{ kJ/kg} \end{array} \right.$$

$$P_e = 175 \text{ kPa} \left\{ \begin{array}{l} h_e = h_{g@175 \text{ kPa}} = 2700.2 \text{ kJ/kg} \\ \text{sat. vapor} \end{array} \right.$$

Analysis We take the cooker as the system, which is a control volume since mass crosses the boundary. Noting that the microscopic energies of flowing and nonflowing fluids are represented by enthalpy h and internal energy u , respectively, the mass and energy balances for this uniform-flow system can be expressed as

$$\text{Mass balance: } m_{\text{in}} - m_{\text{out}} = \Delta m_{\text{system}} \rightarrow m_e = m_1 - m_2$$

$$\text{Energy balance: } \underbrace{E_{\text{in}} - E_{\text{out}}}_{\substack{\text{Net energy transfer} \\ \text{by heat, work, and mass}}} = \underbrace{\Delta E_{\text{system}}}_{\substack{\text{Change in internal, kinetic,} \\ \text{potential, etc. energies}}}$$

$$Q_{\text{in}} - m_e h_e = m_2 u_2 - m_1 u_1 \quad (\text{since } W \cong ke \cong pe \cong 0)$$

The initial mass, initial internal energy, and final mass in the tank are

$$m_1 = m_f + m_g = \frac{\nu_f}{\nu_f} + \frac{\nu_g}{\nu_g} = \frac{0.002 \text{ m}^3}{0.001057 \text{ m}^3/\text{kg}} + \frac{0.002 \text{ m}^3}{1.0036 \text{ m}^3/\text{kg}} = 1.893 + 0.002 = 1.895 \text{ kg}$$

$$U_1 = m_1 u_1 = m_f u_f + m_g u_g = (1.893)(486.82) + (0.002)(2524.5) = 926.6 \text{ kJ}$$

$$m_2 = \frac{\nu}{\nu_2} = \frac{0.004 \text{ m}^3}{1.0037 \text{ m}^3/\text{kg}} = 0.004 \text{ kg}$$

Then from the mass and energy balances,

$$m_e = m_1 - m_2 = 1.895 - 0.004 = 1.891 \text{ kg}$$

$$Q_{\text{in}} = m_e h_e + m_2 u_2 - m_1 u_1$$

$$= (1.891 \text{ kg})(2700.2 \text{ kJ/kg}) + (0.004 \text{ kg})(2524.5 \text{ kJ/kg}) - 926.6 \text{ kJ} = 4188 \text{ kJ}$$

Thus,

$$\dot{Q} = \frac{Q}{\Delta t} = \frac{4188 \text{ kJ}}{3600 \text{ s}} = \mathbf{1.163 \text{ kW}}$$

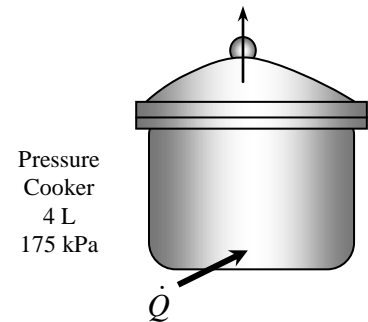

5-118 A cylinder initially contains saturated liquid-vapor mixture of water. The cylinder is connected to a supply line, and the steam is allowed to enter the cylinder until all the liquid is vaporized. The final temperature in the cylinder and the mass of the steam that entered are to be determined.

Assumptions 1 This is an unsteady process since the conditions within the device are changing during the process, but it can be analyzed as a uniform-flow process since the state of fluid at the inlet remains constant. **2** The expansion process is quasi-equilibrium. **3** Kinetic and potential energies are negligible. **3** There are no work interactions involved other than boundary work. **4** The device is insulated and thus heat transfer is negligible.

Properties The properties of steam are (Tables A-4 through A-6)

$$\left. \begin{array}{l} P_1 = 200 \text{ kPa} \\ x_1 = 0.6 \end{array} \right\} h_1 = h_f + x_1 h_{fg} \\ = 504.71 + 0.6 \times 2201.6 = 1825.6 \text{ kJ/kg}$$

$$\left. \begin{array}{l} P_2 = 200 \text{ kPa} \\ \text{sat. vapor} \end{array} \right\} h_2 = h_{g@200\text{kPa}} = 2706.3 \text{ kJ/kg}$$

$$\left. \begin{array}{l} P_i = 0.5 \text{ MPa} \\ T_i = 350^\circ\text{C} \end{array} \right\} h_i = 3168.1 \text{ kJ/kg}$$

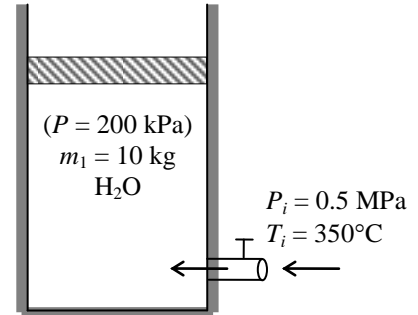

Analysis (a) The cylinder contains saturated vapor at the final state at a pressure of 200 kPa, thus the final temperature in the cylinder must be

$$T_2 = T_{\text{sat @ 200 kPa}} = \mathbf{120.2^\circ\text{C}}$$

(b) We take the cylinder as the system, which is a control volume since mass crosses the boundary. Noting that the microscopic energies of flowing and nonflowing fluids are represented by enthalpy h and internal energy u , respectively, the mass and energy balances for this uniform-flow system can be expressed as

$$\text{Mass balance: } m_{\text{in}} - m_{\text{out}} = \Delta m_{\text{system}} \rightarrow m_i = m_2 - m_1$$

Energy balance:

$$\underbrace{E_{\text{in}} - E_{\text{out}}}_{\text{Net energy transfer by heat, work, and mass}} = \underbrace{\Delta E_{\text{system}}}_{\text{Change in internal, kinetic, potential, etc. energies}} \\ m_i h_i = W_{\text{b,out}} + m_2 u_2 - m_1 u_1 \quad (\text{since } Q \cong ke \cong pe \cong 0)$$

Combining the two relations gives

$$0 = W_{\text{b,out}} - (m_2 - m_1) h_i + m_2 u_2 - m_1 u_1$$

or,

$$0 = -(m_2 - m_1) h_i + m_2 h_2 - m_1 h_1$$

since the boundary work and ΔU combine into ΔH for constant pressure expansion and compression processes. Solving for m_2 and substituting,

$$m_2 = \frac{h_i - h_1}{h_i - h_2} m_1 = \frac{(3168.1 - 1825.6) \text{ kJ/kg}}{(3168.1 - 2706.3) \text{ kJ/kg}} (10 \text{ kg}) = 29.07 \text{ kg}$$

Thus,

$$m_i = m_2 - m_1 = 29.07 - 10 = \mathbf{19.07 \text{ kg}}$$

5-119E A scuba diver's air tank is to be filled with air from a compressed air line. The temperature and mass in the tank at the final state are to be determined.

Assumptions 1 This is an unsteady process since the conditions within the device are changing during the process, but it can be analyzed as a uniform-flow process since the state of fluid at the inlet remains constant. **2** Air is an ideal gas with constant specific heats. **3** Kinetic and potential energies are negligible. **4** There are no work interactions involved. **5** The tank is well-insulated, and thus there is no heat transfer.

Properties The gas constant of air is $0.3704 \text{ psia} \cdot \text{ft}^3/\text{lbm} \cdot \text{R}$ (Table A-1E). The specific heats of air at room temperature are $c_p = 0.240 \text{ Btu}/\text{lbm} \cdot \text{R}$ and $c_v = 0.171 \text{ Btu}/\text{lbm} \cdot \text{R}$ (Table A-2Ea).

Analysis We take the tank as the system, which is a control volume since mass crosses the boundary. Noting that the microscopic energies of flowing and nonflowing fluids are represented by enthalpy h and internal energy u , respectively, the mass and energy balances for this uniform-flow system can be expressed as

Mass balance:

$$m_{\text{in}} - m_{\text{out}} = \Delta m_{\text{system}} \rightarrow m_i = m_2 - m_1$$

Energy balance:

$$\underbrace{E_{\text{in}} - E_{\text{out}}}_{\substack{\text{Net energy transfer} \\ \text{by heat, work, and mass}}} = \underbrace{\Delta E_{\text{system}}}_{\substack{\text{Change in internal, kinetic,} \\ \text{potential, etc. energies}}}$$

$$m_i h_i = m_2 u_2 - m_1 u_1$$

$$m_i c_p T_i = m_2 c_v T_2 - m_1 c_v T_1$$

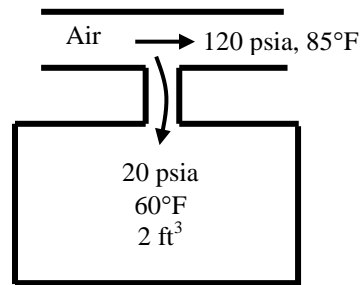

Combining the two balances:

$$(m_2 - m_1)c_p T_i = m_2 c_v T_2 - m_1 c_v T_1$$

The initial and final masses are given by

$$m_1 = \frac{P_1 \mathcal{V}}{RT_1} = \frac{(20 \text{ psia})(2 \text{ ft}^3)}{(0.3704 \text{ psia} \cdot \text{ft}^3/\text{lbm} \cdot \text{R})(60 + 460 \text{ R})} = 0.2077 \text{ lbm}$$

$$m_2 = \frac{P_2 \mathcal{V}}{RT_2} = \frac{(120 \text{ psia})(2 \text{ ft}^3)}{(0.3704 \text{ psia} \cdot \text{ft}^3/\text{lbm} \cdot \text{R})T_2} = \frac{647.9}{T_2}$$

Substituting,

$$\left(\frac{647.9}{T_2} - 0.2077 \right) (0.24)(545) = \frac{647.9}{T_2} (0.171)T_2 - (0.2077)(0.171)(520)$$

whose solution is

$$T_2 = 709.2 \text{ R} = \mathbf{249^\circ\text{F}}$$

The final mass is then

$$m_2 = \frac{647.9}{T_2} = \frac{647.9}{709.2} = \mathbf{0.914 \text{ lbm}}$$

5-120 R-134a from a tank is discharged to an air-conditioning line in an isothermal process. The final quality of the R-134a in the tank and the total heat transfer are to be determined.

Assumptions 1 This is an unsteady process since the conditions within the device are changing during the process, but it can be analyzed as a uniform-flow process since the state of fluid at the exit remains constant. **2** Kinetic and potential energies are negligible. **3** There are no work interactions involved.

Analysis We take the tank as the system, which is a control volume since mass crosses the boundary. Noting that the microscopic energies of flowing and nonflowing fluids are represented by enthalpy h and internal energy u , respectively, the mass and energy balances for this uniform-flow system can be expressed as

Mass balance:

$$\begin{aligned} m_{\text{in}} - m_{\text{out}} &= \Delta m_{\text{system}} \\ -m_e &= m_2 - m_1 \\ m_e &= m_1 - m_2 \end{aligned}$$

Energy balance:

$$\begin{aligned} \underbrace{E_{\text{in}} - E_{\text{out}}}_{\text{Net energy transfer by heat, work, and mass}} &= \underbrace{\Delta E_{\text{system}}}_{\text{Change in internal, kinetic, potential, etc. energies}} \\ Q_{\text{in}} - m_e h_e &= m_2 u_2 - m_1 u_1 \\ Q_{\text{in}} &= m_2 u_2 - m_1 u_1 + m_e h_e \end{aligned}$$

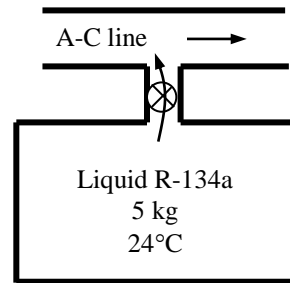

Combining the two balances:

$$Q_{\text{in}} = m_2 u_2 - m_1 u_1 + (m_1 - m_2) h_e$$

The initial state properties of R-134a in the tank are

$$\left. \begin{array}{l} T_1 = 24^\circ\text{C} \\ x = 0 \end{array} \right\} \begin{array}{l} v_1 = 0.0008260 \text{ m}^3/\text{kg} \\ u_1 = 84.44 \text{ kJ/kg} \\ h_e = 84.98 \text{ kJ/kg} \end{array} \quad (\text{Table A-11})$$

Note that we assumed that the refrigerant leaving the tank is at saturated liquid state, and found the exiting enthalpy accordingly. The volume of the tank is

$$V = m_1 v_1 = (5 \text{ kg})(0.0008260 \text{ m}^3/\text{kg}) = 0.004130 \text{ m}^3$$

The final specific volume in the container is

$$v_2 = \frac{V}{m_2} = \frac{0.004130 \text{ m}^3}{0.25 \text{ kg}} = 0.01652 \text{ m}^3/\text{kg}$$

The final state is now fixed. The properties at this state are (Table A-11)

$$\left. \begin{array}{l} T_2 = 24^\circ\text{C} \\ v_2 = 0.01652 \text{ m}^3/\text{kg} \end{array} \right\} \begin{array}{l} x_2 = \frac{v_2 - v_f}{v_{fg}} = \frac{0.01652 - 0.0008260}{0.031869 - 0.0008260} = \mathbf{0.5056} \\ u_2 = u_f + x_2 u_{fg} = 84.44 \text{ kJ/kg} + (0.5056)(158.68 \text{ kJ/kg}) = 164.67 \text{ kJ/kg} \end{array}$$

Substituting into the energy balance equation,

$$\begin{aligned} Q_{\text{in}} &= m_2 u_2 - m_1 u_1 + (m_1 - m_2) h_e \\ &= (0.25 \text{ kg})(164.67 \text{ kJ/kg}) - (5 \text{ kg})(84.44 \text{ kJ/kg}) + (4.75 \text{ kg})(84.98 \text{ kJ/kg}) \\ &= \mathbf{22.6 \text{ kJ}} \end{aligned}$$

5-121E Oxygen is supplied to a medical facility from 10 compressed oxygen tanks in an isothermal process. The mass of oxygen used and the total heat transfer to the tanks are to be determined.

Assumptions 1 This is an unsteady process but it can be analyzed as a uniform-flow process. **2** Oxygen is an ideal gas with constant specific heats. **3** Kinetic and potential energies are negligible. **4** There are no work interactions involved.

Properties The gas constant of oxygen is $0.3353 \text{ psia} \cdot \text{ft}^3/\text{lbm} \cdot \text{R}$ (Table A-1E). The specific heats of oxygen at room temperature are $c_p = 0.219 \text{ Btu}/\text{lbm} \cdot \text{R}$ and $c_v = 0.157 \text{ Btu}/\text{lbm} \cdot \text{R}$ (Table A-2Ea).

Analysis We take the tank as the system, which is a control volume since mass crosses the boundary. Noting that the microscopic energies of flowing and nonflowing fluids are represented by enthalpy h and internal energy u , respectively, the mass and energy balances for this uniform-flow system can be expressed as

Mass balance:

$$m_{\text{in}} - m_{\text{out}} = \Delta m_{\text{system}}$$

$$-m_e = m_2 - m_1$$

$$m_e = m_1 - m_2$$

Energy balance:

$$\underbrace{E_{\text{in}} - E_{\text{out}}}_{\text{Net energy transfer by heat, work, and mass}} = \underbrace{\Delta E_{\text{system}}}_{\text{Change in internal, kinetic, potential, etc. energies}}$$

$$Q_{\text{in}} - m_e h_e = m_2 u_2 - m_1 u_1$$

$$Q_{\text{in}} = m_2 u_2 - m_1 u_1 + m_e h_e$$

$$Q_{\text{in}} = m_2 c_v T_2 - m_1 c_v T_1 + m_e c_p T_e$$

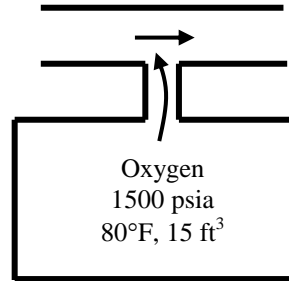

Combining the two balances:

$$Q_{\text{in}} = m_2 c_v T_2 - m_1 c_v T_1 + (m_1 - m_2) c_p T_e$$

The initial and final masses, and the mass used are

$$m_1 = \frac{P_1 \mathcal{V}}{RT_1} = \frac{(1500 \text{ psia})(15 \text{ ft}^3)}{(0.3353 \text{ psia} \cdot \text{ft}^3/\text{lbm} \cdot \text{R})(80 + 460 \text{ R})} = 124.3 \text{ lbm}$$

$$m_2 = \frac{P_2 \mathcal{V}}{RT_2} = \frac{(300 \text{ psia})(15 \text{ ft}^3)}{(0.3353 \text{ psia} \cdot \text{ft}^3/\text{lbm} \cdot \text{R})(80 + 460 \text{ R})} = 24.85 \text{ lbm}$$

$$m_e = m_1 - m_2 = 124.3 - 24.85 = \mathbf{99.41 \text{ lbm}}$$

Substituting into the energy balance equation,

$$\begin{aligned} Q_{\text{in}} &= m_2 c_v T_2 - m_1 c_v T_1 + m_e c_p T_e \\ &= (24.85)(0.157)(540) - (124.3)(0.157)(540) + (99.41)(0.219)(540) \\ &= \mathbf{3328 \text{ Btu}} \end{aligned}$$

5-122 A rigid tank initially contains saturated R-134a vapor. The tank is connected to a supply line, and R-134a is allowed to enter the tank. The mass of the R-134a that entered and the heat transfer are to be determined.

Assumptions 1 This is an unsteady process since the conditions within the device are changing during the process, but it can be analyzed as a uniform-flow process since the state of fluid at the inlet remains constant. **2** Kinetic and potential energies are negligible. **3** There are no work interactions involved. **4** The direction of heat transfer is to the tank (will be verified).

Properties The properties of refrigerant are (Tables A-11 through A-13)

$$\begin{aligned} P_1 = 0.8 \text{ MPa} \left. \begin{array}{l} \nu_1 = \nu_{g@0.8 \text{ MPa}} = 0.02565 \text{ m}^3/\text{kg} \\ \text{sat. vapor} \end{array} \right\} u_1 = u_{g@0.8 \text{ MPa}} = 246.82 \text{ kJ/kg} \\ P_2 = 1.2 \text{ MPa} \left. \begin{array}{l} \nu_2 = \nu_{f@1.2 \text{ MPa}} = 0.0008935 \text{ m}^3/\text{kg} \\ \text{sat. liquid} \end{array} \right\} u_2 = u_{f@1.2 \text{ MPa}} = 116.72 \text{ kJ/kg} \\ P_i = 1.2 \text{ MPa} \left. \begin{array}{l} h_i = h_{f@36^\circ\text{C}} = 102.34 \text{ kJ/kg} \\ T_i = 36^\circ\text{C} \end{array} \right\} \end{aligned}$$

Analysis We take the tank as the system, which is a control volume since mass crosses the boundary. Noting that the microscopic energies of flowing and nonflowing fluids are represented by enthalpy h and internal energy u , respectively, the mass and energy balances for this uniform-flow system can be expressed as

Mass balance:

$$m_{\text{in}} - m_{\text{out}} = \Delta m_{\text{system}} \rightarrow m_i = m_2 - m_1$$

Energy balance:

$$\underbrace{E_{\text{in}} - E_{\text{out}}}_{\substack{\text{Net energy transfer} \\ \text{by heat, work, and mass}}} = \underbrace{\Delta E_{\text{system}}}_{\substack{\text{Change in internal, kinetic,} \\ \text{potential, etc. energies}}} \\ Q_{\text{in}} + m_i h_i = m_2 u_2 - m_1 u_1 \quad (\text{since } W \cong ke \cong pe \cong 0)$$

(a) The initial and the final masses in the tank are

$$\begin{aligned} m_1 &= \frac{\nu_1}{\nu_1} = \frac{0.06 \text{ m}^3}{0.02565 \text{ m}^3/\text{kg}} = 2.340 \text{ kg} \\ m_2 &= \frac{\nu_2}{\nu_2} = \frac{0.06 \text{ m}^3}{0.0008935 \text{ m}^3/\text{kg}} = 67.16 \text{ kg} \end{aligned}$$

Then from the mass balance

$$m_i = m_2 - m_1 = 67.16 - 2.340 = \mathbf{64.82 \text{ kg}}$$

(c) The heat transfer during this process is determined from the energy balance to be

$$\begin{aligned} Q_{\text{in}} &= -m_i h_i + m_2 u_2 - m_1 u_1 \\ &= -(64.82 \text{ kg})(102.34 \text{ kJ/kg}) + (67.16 \text{ kg})(116.72 \text{ kJ/kg}) - (2.340 \text{ kg})(246.82 \text{ kJ/kg}) \\ &= \mathbf{627 \text{ kJ}} \end{aligned}$$

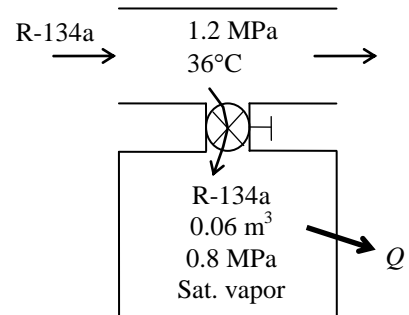

5-123 A rigid tank initially contains saturated liquid water. A valve at the bottom of the tank is opened, and half of the mass in liquid form is withdrawn from the tank. The temperature in the tank is maintained constant. The amount of heat transfer is to be determined.

Assumptions 1 This is an unsteady process since the conditions within the device are changing during the process, but it can be analyzed as a uniform-flow process since the state of fluid leaving the device remains constant. **2** Kinetic and potential energies are negligible. **3** There are no work interactions involved. **4** The direction of heat transfer is to the tank (will be verified).

Properties The properties of water are (Tables A-4 through A-6)

$$\left. \begin{array}{l} T_1 = 200^\circ\text{C} \\ \text{sat. liquid} \end{array} \right\} \begin{array}{l} v_1 = v_{f@200^\circ\text{C}} = 0.001157 \text{ m}^3/\text{kg} \\ u_1 = u_{f@200^\circ\text{C}} = 850.46 \text{ kJ/kg} \end{array}$$

$$\left. \begin{array}{l} T_e = 200^\circ\text{C} \\ \text{sat. liquid} \end{array} \right\} h_e = h_{f@200^\circ\text{C}} = 852.26 \text{ kJ/kg}$$

Analysis We take the tank as the system, which is a control volume since mass crosses the boundary. Noting that the microscopic energies of flowing and nonflowing fluids are represented by enthalpy h and internal energy u , respectively, the mass and energy balances for this uniform-flow system can be expressed as

$$\text{Mass balance:} \quad m_{\text{in}} - m_{\text{out}} = \Delta m_{\text{system}} \rightarrow m_e = m_1 - m_2$$

Energy balance:

$$\underbrace{E_{\text{in}} - E_{\text{out}}}_{\substack{\text{Net energy transfer} \\ \text{by heat, work, and mass}}} = \underbrace{\Delta E_{\text{system}}}_{\substack{\text{Change in internal, kinetic,} \\ \text{potential, etc. energies}}}$$

$$Q_{\text{in}} = m_e h_e + m_2 u_2 - m_1 u_1 \quad (\text{since } W \cong ke \cong pe \cong 0)$$

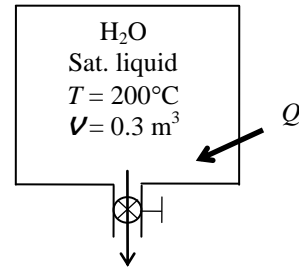

The initial and the final masses in the tank are

$$m_1 = \frac{V_1}{v_1} = \frac{0.3 \text{ m}^3}{0.001157 \text{ m}^3/\text{kg}} = 259.4 \text{ kg}$$

$$m_2 = \frac{1}{2} m_1 = \frac{1}{2} (259.4 \text{ kg}) = 129.7 \text{ kg}$$

Then from the mass balance,

$$m_e = m_1 - m_2 = 259.4 - 129.7 = 129.7 \text{ kg}$$

Now we determine the final internal energy,

$$v_2 = \frac{V}{m_2} = \frac{0.3 \text{ m}^3}{129.7 \text{ kg}} = 0.002313 \text{ m}^3/\text{kg}$$

$$x_2 = \frac{v_2 - v_f}{v_{fg}} = \frac{0.002313 - 0.001157}{0.12721 - 0.001157} = 0.009171$$

$$\left. \begin{array}{l} T_2 = 200^\circ\text{C} \\ x_2 = 0.009171 \end{array} \right\} u_2 = u_f + x_2 u_{fg} = 850.46 + (0.009171)(1743.7) = 866.46 \text{ kJ/kg}$$

Then the heat transfer during this process is determined from the energy balance by substitution to be

$$Q = (129.7 \text{ kg})(852.26 \text{ kJ/kg}) + (129.7 \text{ kg})(866.46 \text{ kJ/kg}) - (259.4 \text{ kg})(850.46 \text{ kJ/kg})$$

$$= \mathbf{2308 \text{ kJ}}$$

5-124E A rigid tank initially contains saturated liquid-vapor mixture of R-134a. A valve at the top of the tank is opened, and vapor is allowed to escape at constant pressure until all the liquid in the tank disappears. The amount of heat transfer is to be determined.

Assumptions 1 This is an unsteady process since the conditions within the device are changing during the process, but it can be analyzed as a uniform-flow process since the state of fluid leaving the device remains constant. **2** Kinetic and potential energies are negligible. **3** There are no work interactions involved.

Properties The properties of R-134a are (Tables A-11E through A-13E)

$$P_1 = 160 \text{ psia} \rightarrow \nu_f = 0.01413 \text{ ft}^3/\text{lbm}, \nu_g = 0.29339 \text{ ft}^3/\text{lbm}$$

$$u_f = 48.11 \text{ Btu/lbm}, u_g = 108.51 \text{ Btu/lbm}$$

$$P_2 = 160 \text{ psia} \left\{ \begin{array}{l} \nu_2 = \nu_g @ 160 \text{ psia} = 0.29339 \text{ ft}^3/\text{lbm} \\ \text{sat. vapor} \end{array} \right. \left\{ \begin{array}{l} u_2 = u_g @ 160 \text{ psia} = 108.51 \text{ Btu/lbm} \end{array} \right.$$

$$P_e = 160 \text{ psia} \left\{ \begin{array}{l} \text{sat. vapor} \end{array} \right. \left\{ \begin{array}{l} h_e = h_g @ 160 \text{ psia} = 117.20 \text{ Btu/lbm} \end{array} \right.$$

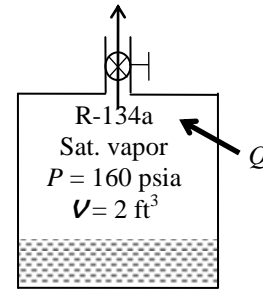

Analysis We take the tank as the system, which is a control volume since mass crosses the boundary. Noting that the microscopic energies of flowing and nonflowing fluids are represented by enthalpy h and internal energy u , respectively, the mass and energy balances for this uniform-flow system can be expressed as

Mass balance:

$$m_{\text{in}} - m_{\text{out}} = \Delta m_{\text{system}} \rightarrow m_e = m_1 - m_2$$

Energy balance:

$$\underbrace{E_{\text{in}} - E_{\text{out}}}_{\text{Net energy transfer by heat, work, and mass}} = \underbrace{\Delta E_{\text{system}}}_{\text{Change in internal, kinetic, potential, etc. energies}}$$

$$Q_{\text{in}} - m_e h_e = m_2 u_2 - m_1 u_1 \quad (\text{since } W \cong ke \cong pe \cong 0)$$

The initial mass, initial internal energy, and final mass in the tank are

$$m_1 = m_f + m_g = \frac{\nu_f}{\nu_f} + \frac{\nu_g}{\nu_g} = \frac{2 \times 0.2 \text{ ft}^3}{0.01413 \text{ ft}^3/\text{lbm}} + \frac{2 \times 0.8 \text{ ft}^3}{0.29339 \text{ ft}^3/\text{lbm}} = 7.077 + 6.476 = 13.553 \text{ lbm}$$

$$U_1 = m_1 u_1 = m_f u_f + m_g u_g = (7.077)(48.11) + (6.476)(108.51) = 1043.2 \text{ Btu}$$

$$m_2 = \frac{\nu}{\nu_2} = \frac{2 \text{ ft}^3}{0.29339 \text{ ft}^3/\text{lbm}} = 6.817 \text{ lbm}$$

Then from the mass and energy balances,

$$m_e = m_1 - m_2 = 13.553 - 6.817 = 6.736 \text{ lbm}$$

$$Q_{\text{in}} = m_e h_e + m_2 u_2 - m_1 u_1$$

$$= (6.736 \text{ lbm})(117.20 \text{ Btu/lbm}) + (6.817 \text{ lbm})(108.51 \text{ Btu/lbm}) - 1043.2 \text{ Btu}$$

$$= \mathbf{486 \text{ Btu}}$$

5-125 A rigid tank initially contains saturated R-134a liquid-vapor mixture. The tank is connected to a supply line, and R-134a is allowed to enter the tank. The final temperature in the tank, the mass of R-134a that entered, and the heat transfer are to be determined.

Assumptions 1 This is an unsteady process since the conditions within the device are changing during the process, but it can be analyzed as a uniform-flow process since the state of fluid at the inlet remains constant. **2** Kinetic and potential energies are negligible. **3** There are no work interactions involved. **4** The direction of heat transfer is to the tank (will be verified).

Properties The properties of refrigerant are (Tables A-11 through A-13)

$$\left. \begin{array}{l} T_1 = 14^\circ\text{C} \\ x_1 = 0.55 \end{array} \right\} \begin{array}{l} \nu_1 = \nu_f + x_1\nu_{fg} = 0.0008018 + 0.55 \times (0.04347 - 0.0008018) = 0.02427 \text{ m}^3/\text{kg} \\ u_1 = u_f + x_1u_{fg} = 70.56 + 0.55 \times 167.30 = 162.57 \text{ kJ/kg} \end{array}$$

$$\left. \begin{array}{l} P_2 = 1 \text{ MPa} \\ \text{sat. vapor} \end{array} \right\} \begin{array}{l} \nu_2 = \nu_{g@1 \text{ MPa}} = 0.02033 \text{ m}^3/\text{kg} \\ u_2 = u_{g@1 \text{ MPa}} = 250.71 \text{ kJ/kg} \end{array}$$

$$\left. \begin{array}{l} P_i = 1.4 \text{ MPa} \\ T_i = 100^\circ\text{C} \end{array} \right\} h_i = 330.32 \text{ kJ/kg}$$

Analysis We take the tank as the system, which is a control volume since mass crosses the boundary. Noting that the microscopic energies of flowing and nonflowing fluids are represented by enthalpy h and internal energy u , respectively, the mass and energy balances for this uniform-flow system can be expressed as

$$\text{Mass balance: } m_{\text{in}} - m_{\text{out}} = \Delta m_{\text{system}} \rightarrow m_i = m_2 - m_1$$

Energy balance:

$$\underbrace{E_{\text{in}} - E_{\text{out}}}_{\substack{\text{Net energy transfer} \\ \text{by heat, work, and mass}}} = \underbrace{\Delta E_{\text{system}}}_{\substack{\text{Change in internal, kinetic,} \\ \text{potential, etc. energies}}}$$

$$Q_{\text{in}} + m_i h_i = m_2 u_2 - m_1 u_1 \quad (\text{since } W \cong ke \cong pe \cong 0)$$

(a) The tank contains saturated vapor at the final state at 800 kPa, and thus the final temperature is the saturation temperature at this pressure,

$$T_2 = T_{\text{sat}@1 \text{ MPa}} = \mathbf{39.4^\circ\text{C}}$$

(b) The initial and the final masses in the tank are

$$m_1 = \frac{\nu}{\nu_1} = \frac{0.3 \text{ m}^3}{0.02427 \text{ m}^3/\text{kg}} = 12.36 \text{ kg}$$

$$m_2 = \frac{\nu}{\nu_2} = \frac{0.3 \text{ m}^3}{0.02033 \text{ m}^3/\text{kg}} = 14.76 \text{ kg}$$

Then from the mass balance

$$m_i = m_2 - m_1 = 14.76 - 12.36 = \mathbf{2.396 \text{ kg}}$$

(c) The heat transfer during this process is determined from the energy balance to be

$$\begin{aligned} Q_{\text{in}} &= -m_i h_i + m_2 u_2 - m_1 u_1 \\ &= -(2.396 \text{ kg})(330.32 \text{ kJ/kg}) + (14.76 \text{ kg})(250.71 \text{ kJ/kg}) - (12.36 \text{ kg})(162.57 \text{ kJ/kg}) \\ &= \mathbf{899 \text{ kJ}} \end{aligned}$$

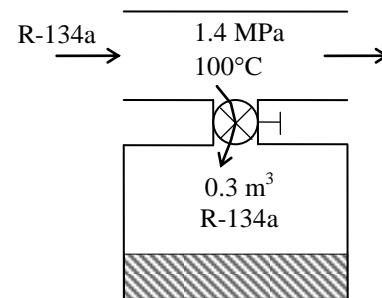

5-126 A large reservoir supplies steam to a balloon whose initial state is specified. The final temperature in the balloon and the boundary work are to be determined.

Analysis Noting that the volume changes linearly with the pressure, the final volume and the initial mass are determined from

$$\left. \begin{array}{l} P_1 = 100 \text{ kPa} \\ T_1 = 150^\circ\text{C} \end{array} \right\} \nu_1 = 1.9367 \text{ m}^3/\text{kg} \quad (\text{Table A-6})$$

$$\nu_2 = \frac{P_2}{P_1} \nu_1 = \frac{150 \text{ kPa}}{100 \text{ kPa}} (50 \text{ m}^3) = 75 \text{ m}^3$$

$$m_1 = \frac{\nu_1}{\nu_1} = \frac{50 \text{ m}^3}{1.9367 \text{ m}^3/\text{kg}} = 25.82 \text{ kg}$$

The final temperature may be determined if we first calculate specific volume at the final state

$$\nu_2 = \frac{V_2}{m_2} = \frac{V_2}{2m_1} = \frac{75 \text{ m}^3}{2 \times (25.82 \text{ kg})} = 1.4525 \text{ m}^3/\text{kg}$$

$$\left. \begin{array}{l} P_2 = 150 \text{ kPa} \\ \nu_2 = 1.4525 \text{ m}^3/\text{kg} \end{array} \right\} T_2 = \mathbf{202.5^\circ\text{C}} \quad (\text{Table A-6})$$

Noting again that the volume changes linearly with the pressure, the boundary work can be determined from

$$W_b = \frac{P_1 + P_2}{2} (\nu_2 - \nu_1) = \frac{(100 + 150) \text{ kPa}}{2} (75 - 50) \text{ m}^3 = \mathbf{3125 \text{ kJ}}$$

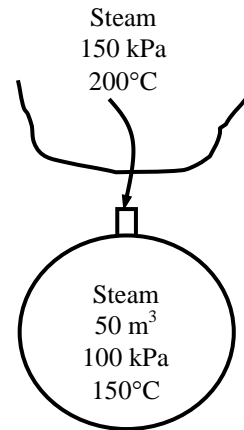

5-127 A hot-air balloon is considered. The final volume of the balloon and work produced by the air inside the balloon as it expands the balloon skin are to be determined.

Assumptions 1 This is an unsteady process since the conditions within the device are changing during the process, but it can be analyzed as a uniform-flow process. **2** Air is an ideal gas with constant specific heats. **3** Kinetic and potential energies are negligible. **4** There is no heat transfer.

Properties The gas constant of air is $0.287 \text{ kPa} \cdot \text{m}^3/\text{kg} \cdot \text{K}$ (Table A-1).

Analysis The specific volume of the air at the entrance and exit, and in the balloon is

$$\nu = \frac{RT}{P} = \frac{(0.287 \text{ kPa} \cdot \text{m}^3/\text{kg} \cdot \text{K})(35 + 273 \text{ K})}{100 \text{ kPa}} = 0.8840 \text{ m}^3/\text{kg}$$

The mass flow rate at the entrance is then

$$\dot{m}_i = \frac{A_i V_i}{\nu} = \frac{(1 \text{ m}^2)(2 \text{ m/s})}{0.8840 \text{ m}^3/\text{kg}} = 2.262 \text{ kg/s}$$

while that at the outlet is

$$\dot{m}_e = \frac{A_e V_e}{\nu} = \frac{(0.5 \text{ m}^2)(1 \text{ m/s})}{0.8840 \text{ m}^3/\text{kg}} = 0.5656 \text{ kg/s}$$

Applying a mass balance to the balloon,

$$m_{i,\text{in}} - m_{\text{out}} = \Delta m_{\text{system}}$$

$$m_i - m_e = m_2 - m_1$$

$$m_2 - m_1 = (\dot{m}_i - \dot{m}_e)\Delta t = [(2.262 - 0.5656) \text{ kg/s}](2 \times 60 \text{ s}) = 203.6 \text{ kg}$$

The volume in the balloon then changes by the amount

$$\Delta \mathcal{V} = (m_2 - m_1)\nu = (203.6 \text{ kg})(0.8840 \text{ m}^3/\text{kg}) = 180 \text{ m}^3$$

and the final volume of the balloon is

$$\mathcal{V}_2 = \mathcal{V}_1 + \Delta \mathcal{V} = 75 + 180 = \mathbf{255 \text{ m}^3}$$

In order to push back the boundary of the balloon against the surrounding atmosphere, the amount of work that must be done is

$$W_{b,\text{out}} = P\Delta \mathcal{V} = (100 \text{ kPa})(180 \text{ m}^3) \left(\frac{1 \text{ kJ}}{1 \text{ kPa} \cdot \text{m}^3} \right) = \mathbf{18,000 \text{ kJ}}$$

5-128 An insulated rigid tank initially contains helium gas at high pressure. A valve is opened, and half of the mass of helium is allowed to escape. The final temperature and pressure in the tank are to be determined.

Assumptions 1 This is an unsteady process since the conditions within the device are changing during the process, but it can be analyzed as a uniform-flow process by using constant average properties for the helium leaving the tank. **2** Kinetic and potential energies are negligible. **3** There are no work interactions involved. **4** The tank is insulated and thus heat transfer is negligible. **5** Helium is an ideal gas with constant specific heats.

Properties The specific heat ratio of helium is $k = 1.667$ (Table A-2).

Analysis We take the tank as the system, which is a control volume since mass crosses the boundary. Noting that the microscopic energies of flowing and nonflowing fluids are represented by enthalpy h and internal energy u , respectively, the mass and energy balances for this uniform-flow system can be expressed as

$$\text{Mass balance:} \quad m_{\text{in}} - m_{\text{out}} = \Delta m_{\text{system}} \rightarrow m_e = m_1 - m_2$$

$$m_2 = \frac{1}{2} m_1 \text{ (given)} \longrightarrow m_e = m_2 = \frac{1}{2} m_1$$

Energy balance:

$$\underbrace{E_{\text{in}} - E_{\text{out}}}_{\text{Net energy transfer by heat, work, and mass}} = \underbrace{\Delta E_{\text{system}}}_{\text{Change in internal, kinetic, potential, etc. energies}}$$

$$-m_e h_e = m_2 u_2 - m_1 u_1 \quad (\text{since } W \cong Q \cong ke \cong pe \cong 0)$$

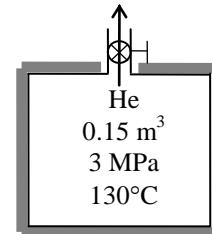

Note that the state and thus the enthalpy of helium leaving the tank is changing during this process. But for simplicity, we assume constant properties for the exiting steam at the average values.

$$\text{Combining the mass and energy balances:} \quad 0 = \frac{1}{2} m_1 h_e + \frac{1}{2} m_1 u_2 - m_1 u_1$$

$$\text{Dividing by } m_1/2 \quad 0 = h_e + u_2 - 2u_1 \quad \text{or} \quad 0 = c_p \frac{T_1 + T_2}{2} + c_v T_2 - 2c_v T_1$$

$$\text{Dividing by } c_v \quad 0 = k(T_1 + T_2) + 2T_2 - 4T_1 \quad \text{since } k = c_p / c_v$$

$$\text{Solving for } T_2: \quad T_2 = \frac{(4-k)}{(2+k)} T_1 = \frac{(4-1.667)}{(2+1.667)} (403 \text{ K}) = \mathbf{257 \text{ K}}$$

The final pressure in the tank is

$$\frac{P_1 \mathcal{V}}{P_2 \mathcal{V}} = \frac{m_1 R T_1}{m_2 R T_2} \longrightarrow P_2 = \frac{m_2 T_2}{m_1 T_1} P_1 = \frac{1}{2} \frac{257}{403} (3000 \text{ kPa}) = \mathbf{956 \text{ kPa}}$$

5-129E An insulated rigid tank equipped with an electric heater initially contains pressurized air. A valve is opened, and air is allowed to escape at constant temperature until the pressure inside drops to 25 psia. The amount of electrical work transferred is to be determined.

Assumptions 1 This is an unsteady process since the conditions within the device are changing during the process, but it can be analyzed as a uniform-flow process since the exit temperature (and enthalpy) of air remains constant. **2** Kinetic and potential energies are negligible. **3** The tank is insulated and thus heat transfer is negligible. **4** Air is an ideal gas with variable specific heats.

Properties The gas constant of air is $R = 0.3704 \text{ psia}\cdot\text{ft}^3/\text{lbm}\cdot\text{R}$ (Table A-1E). The properties of air are (Table A-17E)

$$\begin{aligned} T_i &= 580 \text{ R} & \longrightarrow & h_i = 138.66 \text{ Btu/lbm} \\ T_1 &= 580 \text{ R} & \longrightarrow & u_1 = 98.90 \text{ Btu/lbm} \\ T_2 &= 580 \text{ R} & \longrightarrow & u_2 = 98.90 \text{ Btu/lbm} \end{aligned}$$

Analysis We take the tank as the system, which is a control volume since mass crosses the boundary. Noting that the microscopic energies of flowing and nonflowing fluids are represented by enthalpy h and internal energy u , respectively, the mass and energy balances for this uniform-flow system can be expressed as

Mass balance:

$$m_{\text{in}} - m_{\text{out}} = \Delta m_{\text{system}} \rightarrow m_e = m_1 - m_2$$

Energy balance:

$$\underbrace{E_{\text{in}} - E_{\text{out}}}_{\substack{\text{Net energy transfer} \\ \text{by heat, work, and mass}}} = \underbrace{\Delta E_{\text{system}}}_{\substack{\text{Change in internal, kinetic,} \\ \text{potential, etc. energies}}}$$

$$W_{e,\text{in}} - m_e h_e = m_2 u_2 - m_1 u_1 \quad (\text{since } Q \cong ke \cong pe \cong 0)$$

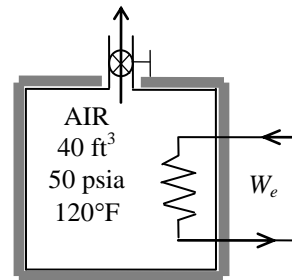

The initial and the final masses of air in the tank are

$$\begin{aligned} m_1 &= \frac{P_1 \mathcal{V}}{RT_1} = \frac{(50 \text{ psia})(40 \text{ ft}^3)}{(0.3704 \text{ psia}\cdot\text{ft}^3/\text{lbm}\cdot\text{R})(580 \text{ R})} = 9.310 \text{ lbm} \\ m_2 &= \frac{P_2 \mathcal{V}}{RT_2} = \frac{(25 \text{ psia})(40 \text{ ft}^3)}{(0.3704 \text{ psia}\cdot\text{ft}^3/\text{lbm}\cdot\text{R})(580 \text{ R})} = 4.655 \text{ lbm} \end{aligned}$$

Then from the mass and energy balances,

$$m_e = m_1 - m_2 = 9.310 - 4.655 = \mathbf{4.655 \text{ kg}}$$

$$\begin{aligned} W_{e,\text{in}} &= m_e h_e + m_2 u_2 - m_1 u_1 \\ &= (4.655 \text{ lbm})(138.66 \text{ Btu/lbm}) + (4.655 \text{ lbm})(98.90 \text{ Btu/lbm}) - (9.310 \text{ lbm})(98.90 \text{ Btu/lbm}) \\ &= \mathbf{185 \text{ Btu}} \end{aligned}$$

5-130 A vertical cylinder initially contains air at room temperature. Now a valve is opened, and air is allowed to escape at constant pressure and temperature until the volume of the cylinder goes down by half. The amount of air that left the cylinder and the amount of heat transfer are to be determined.

Assumptions 1 This is an unsteady process since the conditions within the device are changing during the process, but it can be analyzed as a uniform-flow process since the exit temperature (and enthalpy) of air remains constant. **2** Kinetic and potential energies are negligible. **3** There are no work interactions other than boundary work. **4** Air is an ideal gas with constant specific heats. **5** The direction of heat transfer is to the cylinder (will be verified).

Properties The gas constant of air is $R = 0.287 \text{ kPa}\cdot\text{m}^3/\text{kg}\cdot\text{K}$ (Table A-1).

Analysis (a) We take the cylinder as the system, which is a control volume since mass crosses the boundary. Noting that the microscopic energies of flowing and nonflowing fluids are represented by enthalpy h and internal energy u , respectively, the mass and energy balances for this uniform-flow system can be expressed as

Mass balance:

$$m_{\text{in}} - m_{\text{out}} = \Delta m_{\text{system}} \rightarrow m_e = m_1 - m_2$$

Energy balance:

$$\underbrace{E_{\text{in}} - E_{\text{out}}}_{\substack{\text{Net energy transfer} \\ \text{by heat, work, and mass}}} = \underbrace{\Delta E_{\text{system}}}_{\substack{\text{Change in internal, kinetic,} \\ \text{potential, etc. energies}}}$$

$$Q_{\text{in}} + W_{\text{b,in}} - m_e h_e = m_2 u_2 - m_1 u_1 \quad (\text{since } ke \cong pe \cong 0)$$

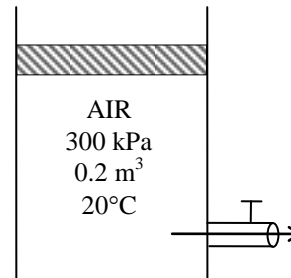

The initial and the final masses of air in the cylinder are

$$m_1 = \frac{P_1 V_1}{RT_1} = \frac{(300 \text{ kPa})(0.2 \text{ m}^3)}{(0.287 \text{ kPa}\cdot\text{m}^3/\text{kg}\cdot\text{K})(293 \text{ K})} = 0.714 \text{ kg}$$

$$m_2 = \frac{P_2 V_2}{RT_2} = \frac{(300 \text{ kPa})(0.1 \text{ m}^3)}{(0.287 \text{ kPa}\cdot\text{m}^3/\text{kg}\cdot\text{K})(293 \text{ K})} = 0.357 \text{ kg} = \frac{1}{2} m_1$$

Then from the mass balance,

$$m_e = m_1 - m_2 = 0.714 - 0.357 = \mathbf{0.357 \text{ kg}}$$

(b) This is a constant pressure process, and thus the W_b and the ΔU terms can be combined into ΔH to yield

$$Q = m_e h_e + m_2 h_2 - m_1 h_1$$

Noting that the temperature of the air remains constant during this process, we have

$$h_i = h_1 = h_2 = h.$$

Also,

$$m_e = m_2 = \frac{1}{2} m_1.$$

Thus,

$$Q = \left(\frac{1}{2} m_1 + \frac{1}{2} m_1 - m_1\right) h = \mathbf{0}$$

5-131 A vertical piston-cylinder device contains air at a specified state. Air is allowed to escape from the cylinder by a valve connected to the cylinder. The final temperature and the boundary work are to be determined.

Properties The gas constant of air is $R = 0.287 \text{ kJ/kg}\cdot\text{K}$ (Table A-1).

Analysis The initial and final masses in the cylinder are

$$m_1 = \frac{P\mathcal{V}_1}{RT_1} = \frac{(600 \text{ kPa})(0.25 \text{ m}^3)}{(0.287 \text{ kJ/kg}\cdot\text{K})(300 + 273 \text{ K})} = 0.9121 \text{ m}^3$$

$$m_2 = 0.25m_1 = 0.25(0.9121 \text{ kg}) = 0.2280 \text{ kg}$$

Then the final temperature becomes

$$T_2 = \frac{P\mathcal{V}_2}{m_2R} = \frac{(600 \text{ kPa})(0.05 \text{ m}^3)}{(0.2280 \text{ kg})(0.287 \text{ kJ/kg}\cdot\text{K})} = \mathbf{458.4 \text{ K}}$$

Noting that pressure remains constant during the process, the boundary work is determined from

$$W_b = P(\mathcal{V}_1 - \mathcal{V}_2) = (600 \text{ kPa})(0.25 - 0.05) \text{ m}^3 = \mathbf{120 \text{ kJ}}$$

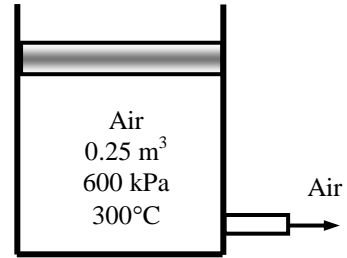

5-132 A cylinder initially contains superheated steam. The cylinder is connected to a supply line, and is superheated steam is allowed to enter the cylinder until the volume doubles at constant pressure. The final temperature in the cylinder and the mass of the steam that entered are to be determined.

Assumptions 1 This is an unsteady process since the conditions within the device are changing during the process, but it can be analyzed as a uniform-flow process since the state of fluid at the inlet remains constant. **2** The expansion process is quasi-equilibrium. **3** Kinetic and potential energies are negligible. **3** There are no work interactions involved other than boundary work. **4** The device is insulated and thus heat transfer is negligible.

Properties The properties of steam are (Tables A-4 through A-6)

$$\left. \begin{array}{l} P_1 = 500 \text{ kPa} \\ T_1 = 200^\circ\text{C} \end{array} \right\} \begin{array}{l} \nu_1 = 0.42503 \text{ m}^3/\text{kg} \\ u_1 = 2643.3 \text{ kJ/kg} \end{array}$$

$$\left. \begin{array}{l} P_i = 1 \text{ MPa} \\ T_i = 350^\circ\text{C} \end{array} \right\} h_i = 3158.2 \text{ kJ/kg}$$

Analysis (a) We take the cylinder as the system, which is a control volume since mass crosses the boundary. Noting that the microscopic energies of flowing and nonflowing fluids are represented by enthalpy h and internal energy u , respectively, the mass and energy balances for this uniform-flow system can be expressed as

$$\text{Mass balance: } m_{\text{in}} - m_{\text{out}} = \Delta m_{\text{system}} \rightarrow m_i = m_2 - m_1$$

$$\text{Energy balance: } \underbrace{E_{\text{in}} - E_{\text{out}}}_{\substack{\text{Net energy transfer} \\ \text{by heat, work, and mass}}} = \underbrace{\Delta E_{\text{system}}}_{\substack{\text{Change in internal, kinetic,} \\ \text{potential, etc. energies}}}$$

$$m_i h_i = W_{b,\text{out}} + m_2 u_2 - m_1 u_1 \quad (\text{since } Q \cong ke \cong pe \cong 0)$$

Combining the two relations gives

$$0 = W_{b,\text{out}} - (m_2 - m_1)h_i + m_2 u_2 - m_1 u_1$$

The boundary work done during this process is

$$W_{b,\text{out}} = \int_1^2 P dV = P(\nu_2 - \nu_1) = (500 \text{ kPa})(0.02 - 0.01) \text{ m}^3 \left(\frac{1 \text{ kJ}}{1 \text{ kPa} \cdot \text{m}^3} \right) = 5 \text{ kJ}$$

The initial and the final masses in the cylinder are

$$m_1 = \frac{V_1}{\nu_1} = \frac{0.01 \text{ m}^3}{0.42503 \text{ m}^3/\text{kg}} = 0.0235 \text{ kg}$$

$$m_2 = \frac{V_2}{\nu_2} = \frac{0.02 \text{ m}^3}{\nu_2}$$

$$\text{Substituting, } 0 = 5 - \left(\frac{0.02}{\nu_2} - 0.0235 \right) (3158.2) + \frac{0.02}{\nu_2} u_2 - (0.0235)(2643.3)$$

Then by trial and error (or using EES program),

$$T_2 = 261.7^\circ\text{C} \quad \text{and} \quad \nu_2 = 0.4858 \text{ m}^3/\text{kg}$$

(b) The final mass in the cylinder is

$$m_2 = \frac{V_2}{\nu_2} = \frac{0.02 \text{ m}^3}{0.4858 \text{ m}^3/\text{kg}} = 0.0412 \text{ kg}$$

$$\text{Then, } m_i = m_2 - m_1 = 0.0412 - 0.0235 = \mathbf{0.0176 \text{ kg}}$$

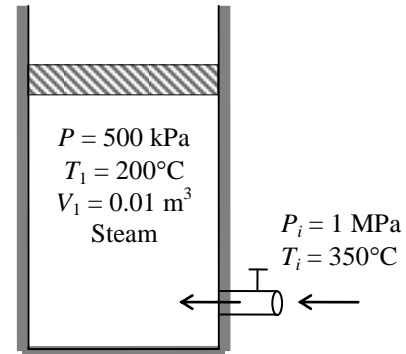

5-133 The air in an insulated, rigid compressed-air tank is released until the pressure in the tank reduces to a specified value. The final temperature of the air in the tank is to be determined.

Assumptions 1 This is an unsteady process since the conditions within the device are changing during the process, but it can be analyzed as a uniform-flow process. **2** Air is an ideal gas with constant specific heats. **3** Kinetic and potential energies are negligible. **4** There are no work interactions involved. **5** The tank is well-insulated, and thus there is no heat transfer.

Properties The gas constant of air is $0.287 \text{ kPa}\cdot\text{m}^3/\text{kg}\cdot\text{K}$ (Table A-1). The specific heats of air at room temperature are $c_p = 1.005 \text{ kJ/kg}\cdot\text{K}$ and $c_v = 0.718 \text{ kJ/kg}\cdot\text{K}$ (Table A-2a).

Analysis We take the tank as the system, which is a control volume since mass crosses the boundary. Noting that the microscopic energies of flowing and nonflowing fluids are represented by enthalpy h and internal energy u , respectively, the mass and energy balances for this uniform-flow system can be expressed as

Mass balance:

$$m_{\text{in}} - m_{\text{out}} = \Delta m_{\text{system}}$$

$$-m_e = m_2 - m_1$$

$$m_e = m_1 - m_2$$

Energy balance:

$$\underbrace{E_{\text{in}} - E_{\text{out}}}_{\text{Net energy transfer by heat, work, and mass}} = \underbrace{\Delta E_{\text{system}}}_{\text{Change in internal, kinetic, potential, etc. energies}}$$

$$-m_e h_e = m_2 u_2 - m_1 u_1$$

$$0 = m_2 u_2 - m_1 u_1 + m_e h_e$$

$$0 = m_2 c_v T_2 - m_1 c_v T_1 + m_e c_p T_e$$

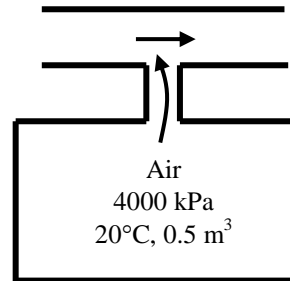

Combining the two balances:

$$0 = m_2 c_v T_2 - m_1 c_v T_1 + (m_1 - m_2) c_p T_e$$

The initial and final masses are given by

$$m_1 = \frac{P_1 \mathcal{V}}{RT_1} = \frac{(4000 \text{ kPa})(0.5 \text{ m}^3)}{(0.287 \text{ kPa}\cdot\text{m}^3/\text{kg}\cdot\text{K})(20 + 273 \text{ K})} = 23.78 \text{ kg}$$

$$m_2 = \frac{P_2 \mathcal{V}}{RT_2} = \frac{(2000 \text{ kPa})(0.5 \text{ m}^3)}{(0.287 \text{ kPa}\cdot\text{m}^3/\text{kg}\cdot\text{K})T_2} = \frac{3484}{T_2}$$

The temperature of air leaving the tank changes from the initial temperature in the tank to the final temperature during the discharging process. We assume that the temperature of the air leaving the tank is the average of initial and final temperatures in the tank. Substituting into the energy balance equation gives

$$0 = m_2 c_v T_2 - m_1 c_v T_1 + (m_1 - m_2) c_p T_e$$

$$0 = \frac{3484}{T_2} (0.718) T_2 - (23.78)(0.718)(293) + \left(23.78 - \frac{3484}{T_2} \right) (1.005) \left(\frac{293 + T_2}{2} \right)$$

whose solution by trial-error or by an equation solver such as EES is

$$T_2 = \mathbf{241\text{K}} = \mathbf{-32^\circ\text{C}}$$

5-134 An insulated piston-cylinder device with a linear spring is applying force to the piston. A valve at the bottom of the cylinder is opened, and refrigerant is allowed to escape. The amount of refrigerant that escapes and the final temperature of the refrigerant are to be determined.

Assumptions 1 This is an unsteady process since the conditions within the device are changing during the process, but it can be analyzed as a uniform-flow process assuming that the state of fluid leaving the device remains constant. **2** Kinetic and potential energies are negligible.

Properties The initial properties of R-134a are (Tables A-11 through A-13)

$$\left. \begin{array}{l} P_1 = 1.4 \text{ MPa} \\ T_1 = 120^\circ\text{C} \end{array} \right\} \begin{array}{l} v_1 = 0.02039 \text{ m}^3/\text{kg} \\ u_1 = 323.57 \text{ kJ/kg} \\ h_1 = 352.11 \text{ kJ/kg} \end{array}$$

Analysis We take the tank as the system, which is a control volume since mass crosses the boundary. Noting that the microscopic energies of flowing and nonflowing fluids are represented by enthalpy h and internal energy u , respectively, the mass and energy balances for this uniform-flow system can be expressed as

$$\text{Mass balance:} \quad m_{\text{in}} - m_{\text{out}} = \Delta m_{\text{system}} \rightarrow m_e = m_1 - m_2$$

Energy balance:

$$\underbrace{E_{\text{in}} - E_{\text{out}}}_{\substack{\text{Net energy transfer} \\ \text{by heat, work, and mass}}} = \underbrace{\Delta E_{\text{system}}}_{\substack{\text{Change in internal, kinetic,} \\ \text{potential, etc. energies}}}$$

$$W_{\text{b,in}} - m_e h_e = m_2 u_2 - m_1 u_1 \quad (\text{since } Q \cong ke \cong pe \cong 0)$$

The initial mass and the relations for the final and exiting masses are

$$m_1 = \frac{V_1}{v_1} = \frac{0.8 \text{ m}^3}{0.02039 \text{ m}^3/\text{kg}} = 39.24 \text{ kg}$$

$$m_2 = \frac{V_2}{v_2} = \frac{0.5 \text{ m}^3}{v_2}$$

$$m_e = m_1 - m_2 = 39.24 - \frac{0.5 \text{ m}^3}{v_2}$$

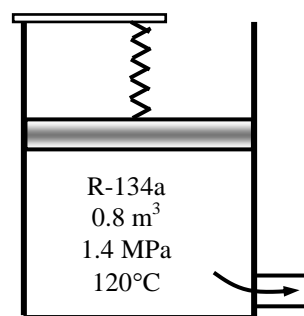

Noting that the spring is linear, the boundary work can be determined from

$$W_{\text{b,in}} = \frac{P_1 + P_2}{2} (V_1 - V_2) = \frac{(1400 + 700) \text{ kPa}}{2} (0.8 - 0.5) \text{ m}^3 = 315 \text{ kJ}$$

Substituting the energy balance,

$$315 - \left(39.24 - \frac{0.5 \text{ m}^3}{v_2} \right) h_e = \left(\frac{0.5 \text{ m}^3}{v_2} \right) u_2 - (39.24 \text{ kg})(323.57 \text{ kJ/kg}) \quad (\text{Eq. 1})$$

where the enthalpy of exiting fluid is assumed to be the average of initial and final enthalpies of the refrigerant in the cylinder. That is,

$$h_e = \frac{h_1 + h_2}{2} = \frac{(352.11 \text{ kJ/kg}) + h_2}{2}$$

Final state properties of the refrigerant (h_2 , u_2 and v_2) are all functions of final pressure (known) and temperature (unknown). The solution may be obtained by a trial-error approach by trying different final state temperatures until Eq. (1) is satisfied. Or solving the above equations simultaneously using an equation solver with built-in thermodynamic functions such as EES, we obtain

$$T_2 = \mathbf{96.2^\circ\text{C}}, \quad m_e = \mathbf{26.8 \text{ kg}}, \quad h_2 = 334.51 \text{ kJ/kg},$$

$$u_2 = 306.43 \text{ kJ/kg}, \quad v_2 = 0.04011 \text{ m}^3/\text{kg}, \quad m_2 = 12.47 \text{ kg}$$

Review Problems

5-135 The air in a hospital room is to be replaced every 15 minutes. The minimum diameter of the duct is to be determined if the air velocity is not to exceed a certain value.

Assumptions 1 The volume occupied by the furniture etc in the room is negligible. **2** The incoming conditioned air does not mix with the air in the room.

Analysis The volume of the room is

$$V = (6 \text{ m})(5 \text{ m})(4 \text{ m}) = 120 \text{ m}^3$$

To empty this air in 20 min, the volume flow rate must be

$$\dot{V} = \frac{V}{\Delta t} = \frac{120 \text{ m}^3}{15 \times 60 \text{ s}} = 0.1333 \text{ m}^3/\text{s}$$

If the mean velocity is 5 m/s, the diameter of the duct is

$$\dot{V} = AV = \frac{\pi D^2}{4} V \rightarrow D = \sqrt{\frac{4\dot{V}}{\pi V}} = \sqrt{\frac{4(0.1333 \text{ m}^3/\text{s})}{\pi(5 \text{ m/s})}} = \mathbf{0.184 \text{ m}}$$

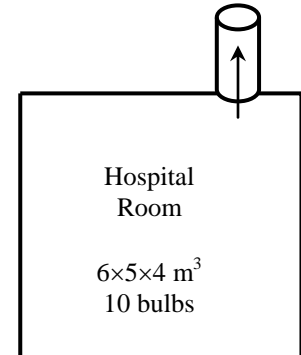

Therefore, the diameter of the duct must be at least 0.184 m to ensure that the air in the room is exchanged completely within 20 min while the mean velocity does not exceed 5 m/s.

Discussion This problem shows that engineering systems are sized to satisfy certain constraints imposed by certain considerations.

5-136 A long roll of large 1-Mn manganese steel plate is to be quenched in an oil bath at a specified rate. The mass flow rate of the plate is to be determined.

Assumptions The plate moves through the bath steadily.

Properties The density of steel plate is given to be $\rho = 7854 \text{ kg/m}^3$.

Analysis The mass flow rate of the sheet metal through the oil bath is

$$\dot{m} = \rho \dot{V} = \rho w t V = (7854 \text{ kg/m}^3)(1 \text{ m})(0.005 \text{ m})(10 \text{ m/min}) = 393 \text{ kg/min} = \mathbf{6.55 \text{ kg/s}}$$

Therefore, steel plate can be treated conveniently as a “flowing fluid” in calculations.



5-137 Air is accelerated in a nozzle. The density of air at the nozzle exit is to be determined.

Assumptions Flow through the nozzle is steady.

Properties The density of air is given to be 4.18 kg/m^3 at the inlet.

Analysis There is only one inlet and one exit, and thus $\dot{m}_1 = \dot{m}_2 = \dot{m}$. Then,

$$\begin{aligned}\dot{m}_1 &= \dot{m}_2 \\ \rho_1 A_1 V_1 &= \rho_2 A_2 V_2 \\ \rho_2 &= \frac{A_1 V_1}{A_2 V_2} \rho_1 = 2 \frac{120 \text{ m/s}}{380 \text{ m/s}} (4.18 \text{ kg/m}^3) = \mathbf{2.64 \text{ kg/m}^3}\end{aligned}$$

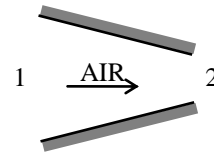

Discussion Note that the density of air decreases considerably despite a decrease in the cross-sectional area of the nozzle.

5-138 An air compressor consumes 6.2 kW of power to compress a specified rate of air. The flow work required by the compressor is to be compared to the power used to increase the pressure of the air.

Assumptions 1 Flow through the compressor is steady. 2 Air is an ideal gas.

Properties The gas constant of air is $0.287 \text{ kPa}\cdot\text{m}^3/\text{kg}\cdot\text{K}$ (Table A-1).

Analysis The specific volume of the air at the inlet is

$$v_1 = \frac{RT_1}{P_1} = \frac{(0.287 \text{ kPa}\cdot\text{m}^3/\text{kg}\cdot\text{K})(20 + 273 \text{ K})}{120 \text{ kPa}} = 0.7008 \text{ m}^3/\text{kg}$$

The mass flow rate of the air is

$$\dot{m} = \frac{\dot{V}_1}{v_1} = \frac{0.015 \text{ m}^3/\text{s}}{0.7008 \text{ m}^3/\text{kg}} = 0.02140 \text{ kg/s}$$

Combining the flow work expression with the ideal gas equation of state gives the flow work as

$$w_{\text{flow}} = P_2 v_2 - P_1 v_1 = R(T_2 - T_1) = (0.287 \text{ kJ/kg}\cdot\text{K})(300 - 20)\text{K} = 80.36 \text{ kJ/kg}$$

The flow power is

$$\dot{W}_{\text{flow}} = \dot{m} w_{\text{flow}} = (0.02140 \text{ kg/s})(80.36 \text{ kJ/kg}) = \mathbf{1.72 \text{ kW}}$$

The remainder of compressor power input is used to increase the pressure of the air:

$$\dot{W} = \dot{W}_{\text{total, in}} - \dot{W}_{\text{flow}} = 6.2 - 1.72 = \mathbf{4.48 \text{ kW}}$$

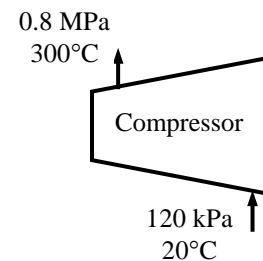

5-139 Saturated refrigerant-134a vapor at a saturation temperature of $T_{\text{sat}} = 34^\circ\text{C}$ condenses inside a tube. The rate of heat transfer from the refrigerant for the condensate exit temperatures of 34°C and 20°C are to be determined.

Assumptions **1** Steady flow conditions exist. **2** Kinetic and potential energy changes are negligible. **3** There are no work interactions involved.

Properties The properties of saturated refrigerant-134a at 34°C are $h_f = 99.41$ kJ/kg, $h_g = 268.61$ kJ/kg, and $h_{fg} = 169.21$ kJ/kg. The enthalpy of saturated liquid refrigerant at 20°C is $h_f = 79.32$ kJ/kg (Table A-11).

Analysis We take the *tube and the refrigerant in it* as the system. This is a *control volume* since mass crosses the system boundary during the process. We note that there is only one inlet and one exit, and thus $\dot{m}_1 = \dot{m}_2 = \dot{m}$. Noting that heat is lost from the system, the energy balance for this steady-flow system can be expressed in the rate form as

$$\underbrace{\dot{E}_{\text{in}} - \dot{E}_{\text{out}}}_{\text{Rate of net energy transfer by heat, work, and mass}} = \underbrace{\Delta \dot{E}_{\text{system}}^{\text{no (steady)}}}_{\text{Rate of change in internal, kinetic, potential, etc. energies}} = 0$$

$$\dot{E}_{\text{in}} = \dot{E}_{\text{out}}$$

$$\dot{m}h_1 = \dot{Q}_{\text{out}} + \dot{m}h_2 \quad (\text{since } \Delta ke \cong \Delta pe \cong 0)$$

$$\dot{Q}_{\text{out}} = \dot{m}(h_1 - h_2)$$

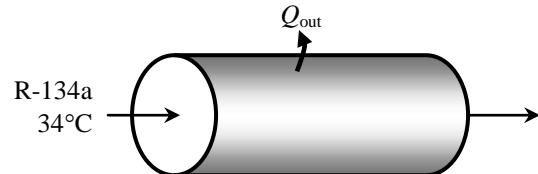

where at the inlet state $h_1 = h_g = 268.61$ kJ/kg. Then the rates of heat transfer during this condensation process for both cases become

Case 1: $T_2 = 34^\circ\text{C}$: $h_2 = h_{f@34^\circ\text{C}} = 99.41$ kJ/kg.

$$\dot{Q}_{\text{out}} = (0.1 \text{ kg/min})(268.61 - 99.41) \text{ kJ/kg} = \mathbf{16.9 \text{ kg/min}}$$

Case 2: $T_2 = 20^\circ\text{C}$: $h_2 \cong h_{f@20^\circ\text{C}} = 79.32$ kJ/kg.

$$\dot{Q}_{\text{out}} = (0.1 \text{ kg/min})(268.61 - 79.32) \text{ kJ/kg} = \mathbf{18.9 \text{ kg/min}}$$

Discussion Note that the rate of heat removal is greater in the second case since the liquid is subcooled in that case.

5-140 Steam expands in a turbine whose power production is 12,350 kW. The rate of heat lost from the turbine is to be determined.

Assumptions 1 This is a steady-flow process since there is no change with time. **2** Kinetic and potential energy changes are negligible.

Properties From the steam tables (Tables A-6 and A-4)

$$\left. \begin{array}{l} P_1 = 1.6 \text{ MPa} \\ T_1 = 350^\circ\text{C} \end{array} \right\} h_1 = 3146.0 \text{ kJ/kg}$$

$$\left. \begin{array}{l} T_2 = 30^\circ\text{C} \\ x_2 = 1 \end{array} \right\} h_2 = 2555.6 \text{ kJ/kg}$$

Analysis We take the turbine as the system, which is a control volume since mass crosses the boundary. Noting that there is one inlet and one exit the energy balance for this steady-flow system can be expressed in the rate form as

$$\underbrace{\dot{E}_{\text{in}} - \dot{E}_{\text{out}}}_{\text{Rate of net energy transfer by heat, work, and mass}} = \underbrace{\Delta \dot{E}_{\text{system}}^{\phi_0} (\text{steady})}_{\text{Rate of change in internal, kinetic, potential, etc. energies}} = 0$$

$$\dot{E}_{\text{in}} = \dot{E}_{\text{out}}$$

$$\dot{m}_1 h_1 = \dot{m}_2 h_2 + \dot{W}_{\text{out}} + \dot{Q}_{\text{out}}$$

$$\dot{Q}_{\text{out}} = \dot{m}(h_1 - h_2) - \dot{W}_{\text{out}}$$

Substituting,

$$\dot{Q}_{\text{out}} = (22 \text{ kg/s})(3146.0 - 2555.6) \text{ kJ/kg} - 12,350 \text{ kW} = \mathbf{640 \text{ kW}}$$

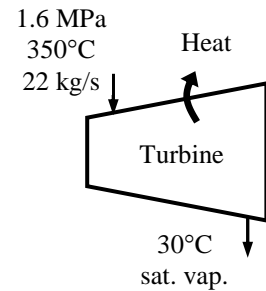

5-141E Nitrogen gas flows through a long, constant-diameter adiabatic pipe. The velocities at the inlet and exit are to be determined.

Assumptions 1 This is a steady-flow process since there is no change with time. **2** Nitrogen is an ideal gas with constant specific heats. **3** Potential energy changes are negligible. **4** There are no work interactions. **5** There is no heat transfer from the nitrogen.

Properties The specific heat of nitrogen at the room temperature is $c_p = 0.248 \text{ Btu/lbm}\cdot\text{R}$ (Table A-2Ea).

Analysis There is only one inlet and one exit, and thus $\dot{m}_1 = \dot{m}_2 = \dot{m}$. We take the pipe as the system, which is a control volume since mass crosses the boundary. The energy balance for this steady-flow system can be expressed in the rate form as

$$\underbrace{\dot{E}_{\text{in}} - \dot{E}_{\text{out}}}_{\substack{\text{Rate of net energy transfer} \\ \text{by heat, work, and mass}}} = \underbrace{\Delta \dot{E}_{\text{system}}}_{\substack{\text{Rate of change in internal, kinetic,} \\ \text{potential, etc. energies}}} \stackrel{\approx 0 \text{ (steady)}}{=} 0$$

$$\dot{E}_{\text{in}} = \dot{E}_{\text{out}}$$

$$\dot{m}(h_1 + V_1^2/2) = \dot{m}(h_2 + V_2^2/2)$$

$$h_1 + V_1^2/2 = h_2 + V_2^2/2$$

$$\frac{V_1^2 - V_2^2}{2} = c_p(T_2 - T_1)$$

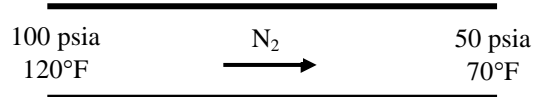

Combining the mass balance and ideal gas equation of state yields

$$\begin{aligned} \dot{m}_1 &= \dot{m}_2 \\ \frac{A_1 V_1}{\nu_1} &= \frac{A_2 V_2}{\nu_2} \\ V_2 &= \frac{A_1}{A_2} \frac{\nu_2}{\nu_1} V_1 = \frac{\nu_2}{\nu_1} V_1 = \frac{T_2}{T_1} \frac{P_1}{P_2} V_1 \end{aligned}$$

Substituting this expression for V_2 into the energy balance equation gives

$$V_1 = \left[\frac{2c_p(T_2 - T_1)}{1 - \left(\frac{T_2}{T_1} \frac{P_1}{P_2} \right)^2} \right]^{0.5} = \left[\frac{2(0.248)(70 - 120)}{1 - \left(\frac{530}{580} \frac{100}{50} \right)^2} \left(\frac{25,037 \text{ ft}^2/\text{s}^2}{1 \text{ Btu/lbm}} \right) \right]^{0.5} = \mathbf{515 \text{ ft/s}}$$

The velocity at the exit is

$$V_2 = \frac{T_2}{T_1} \frac{P_1}{P_2} V_1 = \frac{530}{580} \frac{100}{50} 515 = \mathbf{941 \text{ ft/s}}$$

5-142 Water at a specified rate is heated by an electrical heater. The current is to be determined.

Assumptions 1 This is a steady-flow process since there is no change with time. **2** Kinetic and potential energy changes are negligible. **3** The heat losses from the water is negligible.

Properties The specific heat and the density of water are taken to be $c_p = 4.18 \text{ kJ/kg}\cdot^\circ\text{C}$ and $\rho = 1 \text{ kg/L}$ (Table A-3).

Analysis We take the pipe in which water is heated as the system, which is a control volume. The energy balance for this steady-flow system can be expressed in the rate form as

$$\underbrace{\dot{E}_{\text{in}} - \dot{E}_{\text{out}}}_{\text{Rate of net energy transfer by heat, work, and mass}} = \underbrace{\Delta \dot{E}_{\text{system}}}_{\text{Rate of change in internal, kinetic, potential, etc. energies}} \stackrel{\text{no (steady)}}{=} 0$$

$$\begin{aligned} \dot{E}_{\text{in}} &= \dot{E}_{\text{out}} \\ \dot{m}h_1 + \dot{W}_{\text{e,in}} &= \dot{m}h_2 \\ \dot{W}_{\text{e,in}} &= \dot{m}(h_2 - h_1) \\ \mathbf{VI} &= \dot{m}c_p(T_2 - T_1) \end{aligned}$$

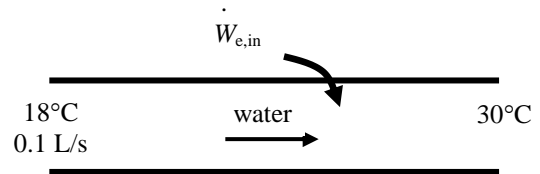

The mass flow rate of the water is

$$\dot{m} = \rho \dot{V} = (1 \text{ kg/L})(0.1 \text{ L/s}) = 0.1 \text{ kg/s}$$

Substituting into the energy balance equation and solving for the current gives

$$I = \frac{\dot{m}c_p(T_2 - T_1)}{\mathbf{V}} = \frac{(0.1 \text{ kg/s})(4.18 \text{ kJ/kg}\cdot\text{K})(30 - 18)\text{K}}{110 \text{ V}} \left(\frac{1000 \text{ V}}{1 \text{ kJ/s}} \right) = \mathbf{45.6 \text{ A}}$$

5-143 Steam flows in an insulated pipe. The mass flow rate of the steam and the speed of the steam at the pipe outlet are to be determined.

Assumptions 1 This is a steady-flow process since there is no change with time. **2** Kinetic and potential energy changes are negligible. **3** There are no work and heat interactions.

Analysis We take the pipe in which steam flows as the system, which is a control volume. The energy balance for this steady-flow system can be expressed in the rate form as

$$\underbrace{\dot{E}_{\text{in}} - \dot{E}_{\text{out}}}_{\text{Rate of net energy transfer by heat, work, and mass}} = \underbrace{\dot{\Delta E}_{\text{system}}^{\text{no (steady)}}}_{\text{Rate of change in internal, kinetic, potential, etc. energies}} = 0$$

$$\dot{E}_{\text{in}} = \dot{E}_{\text{out}}$$

$$\dot{m}h_1 = \dot{m}h_2$$

$$h_1 = h_2$$

1200 kPa, 250°C	Water	1000 kPa
$D = 0.15 \text{ m}$, 4 m/s	\longrightarrow	$D = 0.1 \text{ m}$

The properties of the steam at the inlet and exit are (Table A-6)

$$\left. \begin{array}{l} P = 1200 \text{ kPa} \\ T = 250^\circ\text{C} \end{array} \right\} \begin{array}{l} v_1 = 0.19241 \text{ m}^3/\text{kg} \\ h_1 = 2935.6 \text{ kJ/kg} \end{array}$$

$$\left. \begin{array}{l} P_2 = 1000 \text{ kPa} \\ h_2 = h_1 = 2935.6 \text{ kJ/kg} \end{array} \right\} v_2 = 0.23099 \text{ m}^3/\text{kg}$$

The mass flow rate is

$$\dot{m} = \frac{A_1 V_1}{v_1} = \frac{\pi D_1^2}{4} \frac{V_1}{v_1} = \frac{\pi (0.15 \text{ m})^2}{4} \frac{4 \text{ m/s}}{0.19241 \text{ m}^3/\text{kg}} = \mathbf{0.3674 \text{ kg/s}}$$

The outlet velocity will then be

$$V_2 = \frac{\dot{m} v_2}{A_2} = \frac{4 \dot{m} v_2}{\pi D_2^2} = \frac{4 (0.3674 \text{ kg/s}) (0.23099 \text{ m}^3/\text{kg})}{\pi (0.10 \text{ m})^2} = \mathbf{10.8 \text{ m/s}}$$

5-144 Air flows through a non-constant cross-section pipe. The inlet and exit velocities of the air are to be determined.

Assumptions 1 This is a steady-flow process since there is no change with time. **2** Potential energy change is negligible. **3** There are no work interactions. **4** The device is adiabatic and thus heat transfer is negligible. **5** Air is an ideal gas with constant specific heats.

Properties The gas constant of air is $R = 0.287 \text{ kPa}\cdot\text{m}^3/\text{kg}\cdot\text{K}$. Also, $c_p = 1.005 \text{ kJ}/\text{kg}\cdot\text{K}$ for air at room temperature (Table A-2)

Analysis We take the pipe as the system, which is a control volume since mass crosses the boundary. The mass and energy balances for this steady-flow system can be expressed in the rate form as

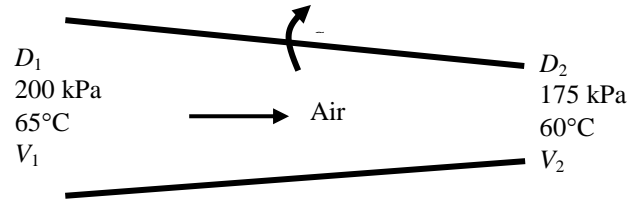

Mass balance:

$$\dot{m}_{\text{in}} - \dot{m}_{\text{out}} = \Delta \dot{m}_{\text{system}} \stackrel{\approx 0 \text{ (steady)}}{=} 0$$

$$\dot{m}_{\text{in}} = \dot{m}_{\text{out}} \longrightarrow \rho_1 A_1 V_1 = \rho_2 A_2 V_2 \longrightarrow \frac{P_1}{RT_1} \frac{\pi D_1^2}{4} V_1 = \frac{P_2}{RT_2} \frac{\pi D_2^2}{4} V_2 \longrightarrow \frac{P_1}{T_1} D_1^2 V_1 = \frac{P_2}{T_2} D_2^2 V_2$$

Energy balance:

$$\underbrace{\dot{E}_{\text{in}} - \dot{E}_{\text{out}}}_{\text{Rate of net energy transfer by heat, work, and mass}} = \underbrace{\Delta \dot{E}_{\text{system}} \stackrel{\approx 0 \text{ (steady)}}{=}}_{\text{Rate of change in internal, kinetic, potential, etc. energies}} = 0 \quad \text{since } \dot{W} \cong \Delta p e \cong 0$$

$$\dot{E}_{\text{in}} = \dot{E}_{\text{out}} \longrightarrow h_1 + \frac{V_1^2}{2} = h_2 + \frac{V_2^2}{2} + q_{\text{out}}$$

or
$$c_p T_1 + \frac{V_1^2}{2} = c_p T_2 + \frac{V_2^2}{2} + q_{\text{out}}$$

Assuming inlet diameter to be 1.4 m and the exit diameter to be 1.0 m, and substituting given values into mass and energy balance equations

$$\left(\frac{200 \text{ kPa}}{338 \text{ K}} \right) (1.4 \text{ m})^2 V_1 = \left(\frac{175 \text{ kPa}}{333 \text{ K}} \right) (1.0 \text{ m})^2 V_2 \quad (1)$$

$$(1.005 \text{ kJ}/\text{kg}\cdot\text{K})(338 \text{ K}) + \frac{V_1^2}{2} \left(\frac{1 \text{ kJ}/\text{kg}}{1000 \text{ m}^2/\text{s}^2} \right) = (1.005 \text{ kJ}/\text{kg}\cdot\text{K})(333 \text{ K}) + \frac{V_2^2}{2} \left(\frac{1 \text{ kJ}/\text{kg}}{1000 \text{ m}^2/\text{s}^2} \right) + 3.3 \text{ kJ}/\text{kg} \quad (2)$$

There are two equations and two unknowns. Solving equations (1) and (2) simultaneously using an equation solver such as EES, the velocities are determined to be

$$V_1 = \mathbf{29.9 \text{ m/s}}$$

$$V_2 = \mathbf{66.1 \text{ m/s}}$$

5-145 Heat is lost from the steam flowing in a nozzle. The exit velocity and the mass flow rate are to be determined.

Assumptions 1 This is a steady-flow process since there is no change with time. **2** Potential energy change is negligible. **3** There are no work interactions.

Analysis (a) We take the steam as the system, which is a control volume since mass crosses the boundary. The energy balance for this steady-flow system can be expressed in the rate form as

Energy balance:

$$\underbrace{\dot{E}_{\text{in}} - \dot{E}_{\text{out}}}_{\text{Rate of net energy transfer by heat, work, and mass}} = \underbrace{\Delta \dot{E}_{\text{system}}}_{\text{Rate of change in internal, kinetic, potential, etc. energies}} \stackrel{\text{no (steady)}}{=} 0$$

$$\dot{E}_{\text{in}} = \dot{E}_{\text{out}}$$

$$\dot{m} \left(h_1 + \frac{V_1^2}{2} \right) = \dot{m} \left(h_2 + \frac{V_2^2}{2} \right) + \dot{Q}_{\text{out}} \quad \text{since } \dot{W} \cong \Delta \text{pe} \cong 0$$

or

$$V_2 = \sqrt{2(h_1 - h_2 - q_{\text{out}})}$$

The properties of steam at the inlet and exit are (Table A-6)

$$\left. \begin{array}{l} P_1 = 200 \text{ kPa} \\ T_1 = 150^\circ\text{C} \end{array} \right\} h_1 = 2769.1 \text{ kJ/kg}$$

$$\left. \begin{array}{l} P_2 = 75 \text{ kPa} \\ \text{sat. vap.} \end{array} \right\} \begin{array}{l} v_2 = 2.2172 \text{ m}^3/\text{kg} \\ h_2 = 2662.4 \text{ kJ/kg} \end{array}$$

Substituting,

$$V_2 = \sqrt{2(h_1 - h_2 - q_{\text{out}})} = \sqrt{2(2769.1 - 2662.4 - 26) \text{ kJ/kg} \left(\frac{1 \text{ kJ/kg}}{1000 \text{ m}^2/\text{s}^2} \right)} = \mathbf{401.7 \text{ m/s}}$$

(b) The mass flow rate of the steam is

$$\dot{m} = \frac{1}{v_2} A_2 V_2 = \frac{1}{2.2172 \text{ m}^3/\text{kg}} (0.001 \text{ m}^2)(401.7 \text{ m/s}) = \mathbf{0.181 \text{ kg/s}}$$

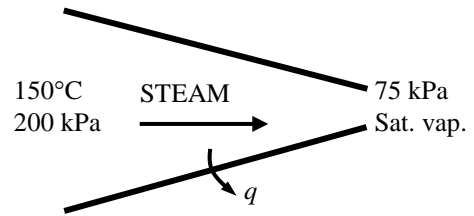

5-146 Water is boiled at a specified temperature by hot gases flowing through a stainless steel pipe submerged in water. The rate of evaporation of is to be determined.

Assumptions 1 Steady operating conditions exist. 2 Heat losses from the outer surfaces of the boiler are negligible.

Properties The enthalpy of vaporization of water at 180°C is $h_{fg} = 2014.2 \text{ kJ/kg}$ (Table A-4).

Analysis The rate of heat transfer to water is given to be 48 kJ/s. Noting that the enthalpy of vaporization represents the amount of energy needed to vaporize a unit mass of a liquid at a specified temperature, the rate of evaporation of water is determined to be

$$\dot{m}_{\text{evaporation}} = \frac{\dot{Q}_{\text{boiling}}}{h_{fg}} = \frac{48 \text{ kJ/s}}{2014.2 \text{ kJ/kg}} = \mathbf{0.0238 \text{ kg/s}}$$

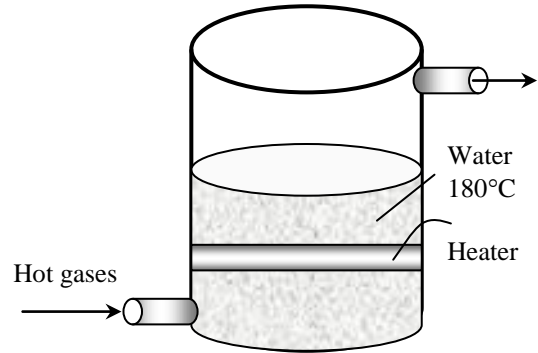

5-147 Saturated steam at 1 atm pressure and thus at a saturation temperature of $T_{\text{sat}} = 100^\circ\text{C}$ condenses on a vertical plate maintained at 90°C by circulating cooling water through the other side. The rate of condensation of steam is to be determined.

Assumptions 1 Steady operating conditions exist. 2 The steam condenses and the condensate drips off at 100°C . (In reality, the condensate temperature will be between 90 and 100, and the cooling of the condensate a few $^\circ\text{C}$ should be considered if better accuracy is desired).

Properties The enthalpy of vaporization of water at 1 atm (101.325 kPa) is $h_{fg} = 2256.5 \text{ kJ/kg}$ (Table A-5).

Analysis The rate of heat transfer during this condensation process is given to be 180 kJ/s. Noting that the heat of vaporization of water represents the amount of heat released as a unit mass of vapor at a specified temperature condenses, the rate of condensation of steam is determined from

$$\dot{m}_{\text{condensation}} = \frac{\dot{Q}}{h_{fg}} = \frac{180 \text{ kJ/s}}{2256.5 \text{ kJ/kg}} = \mathbf{0.0798 \text{ kg/s}}$$

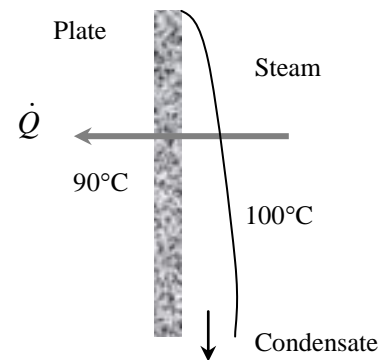

5-148E Saturated steam at a saturation pressure of 0.95 psia and thus at a saturation temperature of $T_{\text{sat}} = 100^\circ\text{F}$ (Table A-4E) condenses on the outer surfaces of 144 horizontal tubes by circulating cooling water arranged in a 12×12 square array. The rate of heat transfer to the cooling water and the average velocity of the cooling water are to be determined.

Assumptions 1 Steady operating conditions exist. 2 The tubes are isothermal. 3 Water is an incompressible substance with constant properties at room temperature. 4 The changes in kinetic and potential energies are negligible.

Properties The properties of water at room temperature are $\rho = 62.1 \text{ lbm/ft}^3$ and $c_p = 1.00 \text{ Btu/lbm}\cdot^\circ\text{F}$ (Table A-3E). The enthalpy of vaporization of water at a saturation pressure of 0.95 psia is $h_{fg} = 1036.7 \text{ Btu/lbm}$ (Table A-4E).

Analysis (a) The rate of heat transfer from the steam to the cooling water is equal to the heat of vaporization released as the vapor condenses at the specified temperature,

$$\dot{Q} = \dot{m}h_{fg} = (6800 \text{ lbm/h})(1036.7 \text{ Btu/lbm}) = \mathbf{7,049,560 \text{ Btu/h} = 1958 \text{ Btu/s}}$$

(b) All of this energy is transferred to the cold water. Therefore, the mass flow rate of cold water must be

$$\dot{Q} = \dot{m}_{\text{water}} c_p \Delta T \rightarrow \dot{m}_{\text{water}} = \frac{\dot{Q}}{c_p \Delta T} = \frac{1958 \text{ Btu/s}}{(1.00 \text{ Btu/lbm}\cdot^\circ\text{F})(8^\circ\text{F})} = 244.8 \text{ lbm/s}$$

Then the average velocity of the cooling water through the 144 tubes becomes

$$\dot{m} = \rho AV \rightarrow V = \frac{\dot{m}}{\rho A} = \frac{\dot{m}}{\rho(n\pi D^2/4)} = \frac{244.8 \text{ lbm/s}}{(62.1 \text{ lbm/ft}^3)[144\pi(1/12 \text{ ft})^2/4]} = \mathbf{5.02 \text{ ft/s}}$$

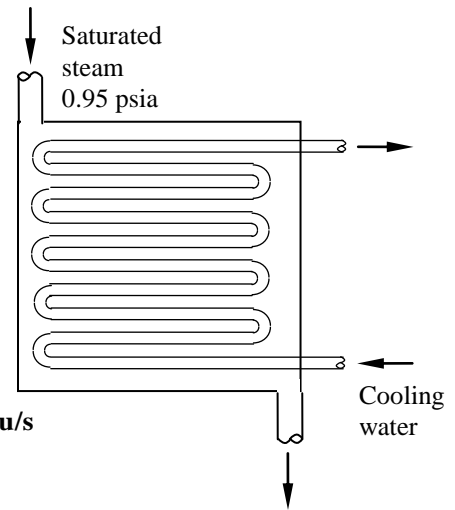

5-149 The feedwater of a steam power plant is preheated using steam extracted from the turbine. The ratio of the mass flow rates of the extracted steam to the feedwater are to be determined.

Assumptions 1 This is a steady-flow process since there is no change with time. **2** Kinetic and potential energy changes are negligible. **3** There are no work interactions. **4** Heat loss from the device to the surroundings is negligible and thus heat transfer from the hot fluid is equal to the heat transfer to the cold fluid.

Properties The enthalpies of steam and feedwater are (Tables A-4 through A-6)

$$\left. \begin{array}{l} P_1 = 1 \text{ MPa} \\ T_1 = 200^\circ\text{C} \end{array} \right\} h_1 = 2828.3 \text{ kJ/kg}$$

$$\left. \begin{array}{l} P_1 = 1 \text{ MPa} \\ \text{sat. liquid} \end{array} \right\} \begin{array}{l} h_2 = h_{f@1\text{MPa}} = 762.51 \text{ kJ/kg} \\ T_2 = 179.9^\circ\text{C} \end{array}$$

and

$$\left. \begin{array}{l} P_3 = 2.5 \text{ MPa} \\ T_3 = 50^\circ\text{C} \end{array} \right\} h_3 \cong h_{f@50^\circ\text{C}} = 209.34 \text{ kJ/kg}$$

$$\left. \begin{array}{l} P_4 = 2.5 \text{ MPa} \\ T_4 = T_2 - 10 \cong 170^\circ\text{C} \end{array} \right\} h_4 \cong h_{f@170^\circ\text{C}} = 718.55 \text{ kJ/kg}$$

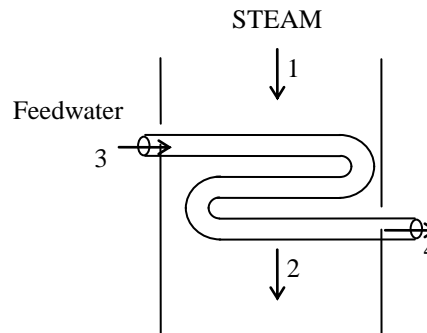

Analysis We take the heat exchanger as the system, which is a control volume. The mass and energy balances for this steady-flow system can be expressed in the rate form as

Mass balance (for each fluid stream):

$$\dot{m}_{\text{in}} - \dot{m}_{\text{out}} = \Delta \dot{m}_{\text{system}} \stackrel{\text{no (steady)}}{=} 0 \rightarrow \dot{m}_{\text{in}} = \dot{m}_{\text{out}} \rightarrow \dot{m}_1 = \dot{m}_2 = \dot{m}_s \text{ and } \dot{m}_3 = \dot{m}_4 = \dot{m}_{\text{fw}}$$

Energy balance (for the heat exchanger):

$$\underbrace{\dot{E}_{\text{in}} - \dot{E}_{\text{out}}}_{\text{Rate of net energy transfer by heat, work, and mass}} = \underbrace{\Delta \dot{E}_{\text{system}}}_{\text{Rate of change in internal, kinetic, potential, etc. energies}} \stackrel{\text{no (steady)}}{=} 0$$

$$\dot{E}_{\text{in}} = \dot{E}_{\text{out}}$$

$$\dot{m}_1 h_1 + \dot{m}_3 h_3 = \dot{m}_2 h_2 + \dot{m}_4 h_4 \quad (\text{since } \dot{Q} = \dot{W} = \Delta \text{ke} \cong \Delta \text{pe} \cong 0)$$

Combining the two,

$$\dot{m}_s (h_2 - h_1) = \dot{m}_{\text{fw}} (h_3 - h_4)$$

Dividing by \dot{m}_{fw} and substituting,

$$\frac{\dot{m}_s}{\dot{m}_{\text{fw}}} = \frac{h_3 - h_4}{h_2 - h_1} = \frac{(718.55 - 209.34) \text{ kJ/kg}}{(2828.3 - 762.51) \text{ kJ/kg}} = \mathbf{0.246}$$

5-150 Cold water enters a steam generator at 20°C , and leaves as saturated vapor at $T_{\text{sat}} = 200^\circ\text{C}$. The fraction of heat used to preheat the liquid water from 20°C to saturation temperature of 200°C is to be determined.

Assumptions **1** Steady operating conditions exist. **2** Heat losses from the steam generator are negligible. **3** The specific heat of water is constant at the average temperature.

Properties The heat of vaporization of water at 200°C is $h_{fg} = 1939.8 \text{ kJ/kg}$ (Table A-4), and the specific heat of liquid water is $c = 4.18 \text{ kJ/kg}\cdot^\circ\text{C}$ (Table A-3).

Analysis The heat of vaporization of water represents the amount of heat needed to vaporize a unit mass of liquid at a specified temperature. Using the average specific heat, the amount of heat transfer needed to preheat a unit mass of water from 20°C to 200°C is

$$\begin{aligned} q_{\text{preheating}} &= c\Delta T \\ &= (4.18 \text{ kJ/kg}\cdot^\circ\text{C})(200 - 20)^\circ\text{C} \\ &= 752.4 \text{ kJ/kg} \end{aligned}$$

and

$$\begin{aligned} q_{\text{total}} &= q_{\text{boiling}} + q_{\text{preheating}} \\ &= 1939.8 + 752.4 = 2692.2 \text{ kJ/kg} \end{aligned}$$

Therefore, the fraction of heat used to preheat the water is

$$\text{Fraction to preheat} = \frac{q_{\text{preheating}}}{q_{\text{total}}} = \frac{752.4}{2692.2} = \mathbf{0.2795} \text{ (or } \mathbf{28.0\%})$$

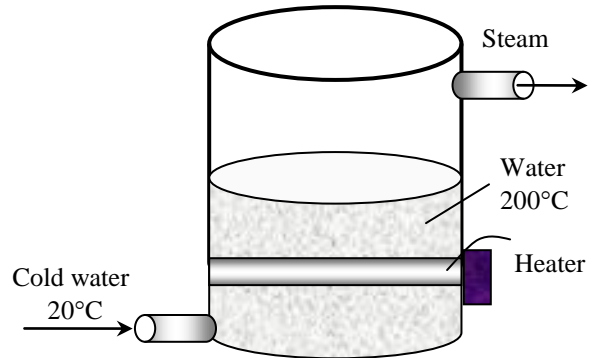

5-151 Cold water enters a steam generator at 20°C and is boiled, and leaves as saturated vapor at boiler pressure. The boiler pressure at which the amount of heat needed to preheat the water to saturation temperature that is equal to the heat of vaporization is to be determined.

Assumptions Heat losses from the steam generator are negligible.

Properties The enthalpy of liquid water at 20°C is 83.91 kJ/kg. Other properties needed to solve this problem are the heat of vaporization h_{fg} and the enthalpy of saturated liquid at the specified temperatures, and they can be obtained from Table A-4.

Analysis The heat of vaporization of water represents the amount of heat needed to vaporize a unit mass of liquid at a specified temperature, and Δh represents the amount of heat needed to preheat a unit mass of water from 20°C to the saturation temperature. Therefore,

$$q_{\text{preheating}} = q_{\text{boiling}}$$

$$(h_{f@T_{\text{sat}}} - h_{f@20^\circ\text{C}}) = h_{fg@T_{\text{sat}}}$$

$$h_{f@T_{\text{sat}}} - 83.91 \text{ kJ/kg} = h_{fg@T_{\text{sat}}} \rightarrow h_{f@T_{\text{sat}}} - h_{fg@T_{\text{sat}}} = 83.91 \text{ kJ/kg}$$

The solution of this problem requires choosing a boiling temperature, reading h_f and h_{fg} at that temperature, and substituting the values into the relation above to see if it is satisfied. By trial and error, (Table A-4)

$$\text{At } 310^\circ\text{C: } h_{f@T_{\text{sat}}} - h_{fg@T_{\text{sat}}} = 1402.0 - 1325.9 = 76.1 \text{ kJ/kg}$$

$$\text{At } 315^\circ\text{C: } h_{f@T_{\text{sat}}} - h_{fg@T_{\text{sat}}} = 1431.6 - 1283.4 = 148.2 \text{ kJ/kg}$$

The temperature that satisfies this condition is determined from the two values above by interpolation to be 310.6°C. The saturation pressure corresponding to this temperature is **9.94 MPa**.

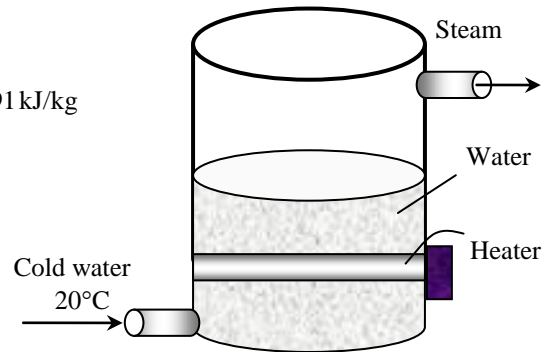

5-152 An ideal gas expands in a turbine. The volume flow rate at the inlet for a power output of 650 kW is to be determined.

Assumptions 1 This is a steady-flow process since there is no change with time. **2** Kinetic and potential energy changes are negligible. **3** The device is adiabatic and thus heat transfer is negligible.

Properties The properties of the ideal gas are given as $R = 0.30 \text{ kPa}\cdot\text{m}^3/\text{kg}\cdot\text{K}$, $c_p = 1.13 \text{ kJ/kg}\cdot^\circ\text{C}$, $c_v = 0.83 \text{ kJ/kg}\cdot^\circ\text{C}$.

Analysis We take the turbine as the system, which is a control volume since mass crosses the boundary. The energy balance for this steady-flow system can be expressed in the rate form as

$$\underbrace{\dot{E}_{\text{in}} - \dot{E}_{\text{out}}}_{\text{Rate of net energy transfer by heat, work, and mass}} = \underbrace{\Delta \dot{E}_{\text{system}}}_{\text{Rate of change in internal, kinetic, potential, etc. energies}} \stackrel{\text{no (steady)}}{=} 0$$

$$\dot{E}_{\text{in}} = \dot{E}_{\text{out}} \rightarrow \dot{m}h_1 = \dot{W}_{\text{out}} + \dot{m}h_2 \quad (\text{since } \dot{Q} \cong \Delta \text{ke} = \Delta \text{pe} \cong 0)$$

which can be rearranged to solve for mass flow rate

$$\dot{m} = \frac{\dot{W}_{\text{out}}}{h_1 - h_2} = \frac{\dot{W}_{\text{out}}}{c_p(T_1 - T_2)} = \frac{650 \text{ kW}}{(1.13 \text{ kJ/kg}\cdot\text{K})(1200 - 800)\text{K}} = 1.438 \text{ kg/s}$$

The inlet specific volume and the volume flow rate are

$$\nu_1 = \frac{RT_1}{P_1} = \frac{(0.3 \text{ kPa}\cdot\text{m}^3/\text{kg}\cdot\text{K})(1200 \text{ K})}{900 \text{ kPa}} = 0.4 \text{ m}^3/\text{kg}$$

$$\text{Thus, } \dot{V} = \dot{m}\nu_1 = (1.438 \text{ kg/s})(0.4 \text{ m}^3/\text{kg}) = \mathbf{0.575 \text{ m}^3/\text{s}}$$

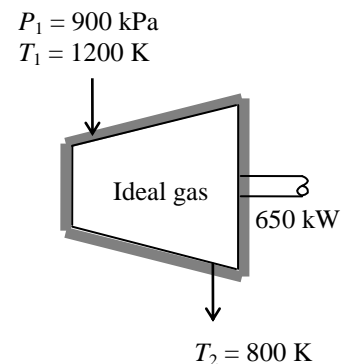

5-153 Chickens are to be cooled by chilled water in an immersion chiller. The rate of heat removal from the chicken and the mass flow rate of water are to be determined.

Assumptions 1 Steady operating conditions exist. 2 The thermal properties of chickens and water are constant.

Properties The specific heat of chicken are given to be 3.54 kJ/kg.°C. The specific heat of water is 4.18 kJ/kg.°C (Table A-3).

Analysis (a) Chickens are dropped into the chiller at a rate of 500 per hour. Therefore, chickens can be considered to flow steadily through the chiller at a mass flow rate of

$$\dot{m}_{\text{chicken}} = (500 \text{ chicken} / \text{h})(2.2 \text{ kg} / \text{chicken}) = 1100 \text{ kg} / \text{h} = 0.3056 \text{ kg} / \text{s}$$

Taking the chicken flow stream in the chiller as the system, the energy balance for steadily flowing chickens can be expressed in the rate form as

$$\underbrace{\dot{E}_{\text{in}} - \dot{E}_{\text{out}}}_{\text{Rate of net energy transfer by heat, work, and mass}} = \underbrace{\dot{\Delta E}_{\text{system}}}_{\text{Rate of change in internal, kinetic, potential, etc. energies}} \stackrel{\text{no (steady)}}{=} 0$$

$$\dot{E}_{\text{in}} = \dot{E}_{\text{out}}$$

$$\dot{m}h_1 = \dot{Q}_{\text{out}} + \dot{m}h_2 \quad (\text{since } \Delta \text{ke} \cong \Delta \text{pe} \cong 0)$$

$$\dot{Q}_{\text{out}} = \dot{Q}_{\text{chicken}} = \dot{m}_{\text{chicken}} c_p (T_1 - T_2)$$

Then the rate of heat removal from the chickens as they are cooled from 15°C to 3°C becomes

$$\dot{Q}_{\text{chicken}} = (\dot{m} c_p \Delta T)_{\text{chicken}} = (0.3056 \text{ kg/s})(3.54 \text{ kJ/kg.}^\circ\text{C})(15 - 3)^\circ\text{C} = \mathbf{13.0 \text{ kW}}$$

The chiller gains heat from the surroundings at a rate of 200 kJ/h = 0.0556 kJ/s. Then the total rate of heat gain by the water is

$$\dot{Q}_{\text{water}} = \dot{Q}_{\text{chicken}} + \dot{Q}_{\text{heat gain}} = 13.0 + 0.056 = 13.056 \text{ kW}$$

Noting that the temperature rise of water is not to exceed 2°C as it flows through the chiller, the mass flow rate of water must be at least

$$\dot{m}_{\text{water}} = \frac{\dot{Q}_{\text{water}}}{(c_p \Delta T)_{\text{water}}} = \frac{13.056 \text{ kW}}{(4.18 \text{ kJ/kg.}^\circ\text{C})(2^\circ\text{C})} = \mathbf{1.56 \text{ kg/s}}$$

If the mass flow rate of water is less than this value, then the temperature rise of water will have to be more than 2°C.

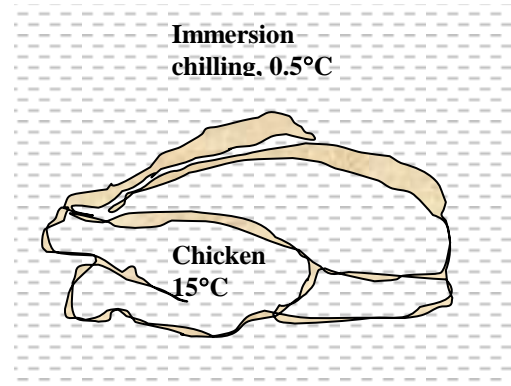

5-154 Chickens are to be cooled by chilled water in an immersion chiller. The rate of heat removal from the chicken and the mass flow rate of water are to be determined.

Assumptions 1 Steady operating conditions exist. 2 The thermal properties of chickens and water are constant. 3 Heat gain of the chiller is negligible.

Properties The specific heat of chicken are given to be $3.54 \text{ kJ/kg}\cdot^\circ\text{C}$. The specific heat of water is $4.18 \text{ kJ/kg}\cdot^\circ\text{C}$ (Table A-3).

Analysis (a) Chickens are dropped into the chiller at a rate of 500 per hour. Therefore, chickens can be considered to flow steadily through the chiller at a mass flow rate of

$$\dot{m}_{\text{chicken}} = (500 \text{ chicken} / \text{h})(2.2 \text{ kg} / \text{chicken}) = 1100 \text{ kg} / \text{h} = 0.3056 \text{ kg} / \text{s}$$

Taking the chicken flow stream in the chiller as the system, the energy balance for steadily flowing chickens can be expressed in the rate form as

$$\underbrace{\dot{E}_{\text{in}} - \dot{E}_{\text{out}}}_{\text{Rate of net energy transfer by heat, work, and mass}} = \underbrace{\Delta \dot{E}_{\text{system}}}_{\text{Rate of change in internal, kinetic, potential, etc. energies}} \stackrel{\approx 0 \text{ (steady)}}{=} 0$$

$$\dot{E}_{\text{in}} = \dot{E}_{\text{out}}$$

$$\dot{m}h_1 = \dot{Q}_{\text{out}} + \dot{m}h_2 \quad (\text{since } \Delta \text{ke} \cong \Delta \text{pe} \cong 0)$$

$$\dot{Q}_{\text{out}} = \dot{Q}_{\text{chicken}} = \dot{m}_{\text{chicken}} c_p (T_1 - T_2)$$

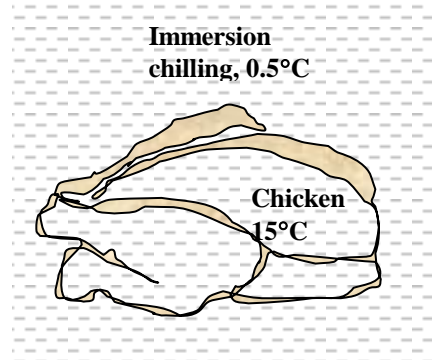

Then the rate of heat removal from the chickens as they are cooled from 15°C to 3°C becomes

$$\dot{Q}_{\text{chicken}} = (\dot{m} c_p \Delta T)_{\text{chicken}} = (0.3056 \text{ kg/s})(3.54 \text{ kJ/kg}\cdot^\circ\text{C})(15 - 3)^\circ\text{C} = \mathbf{13.0 \text{ kW}}$$

Heat gain of the chiller from the surroundings is negligible. Then the total rate of heat gain by the water is

$$\dot{Q}_{\text{water}} = \dot{Q}_{\text{chicken}} = 13.0 \text{ kW}$$

Noting that the temperature rise of water is not to exceed 2°C as it flows through the chiller, the mass flow rate of water must be at least

$$\dot{m}_{\text{water}} = \frac{\dot{Q}_{\text{water}}}{(c_p \Delta T)_{\text{water}}} = \frac{13.0 \text{ kW}}{(4.18 \text{ kJ/kg}\cdot^\circ\text{C})(2^\circ\text{C})} = \mathbf{1.56 \text{ kg/s}}$$

If the mass flow rate of water is less than this value, then the temperature rise of water will have to be more than 2°C .

5-155E A refrigeration system is to cool eggs by chilled air at a rate of 10,000 eggs per hour. The rate of heat removal from the eggs, the required volume flow rate of air, and the size of the compressor of the refrigeration system are to be determined.

Assumptions **1** Steady operating conditions exist. **2** The eggs are at uniform temperatures before and after cooling. **3** The cooling section is well-insulated. **4** The properties of eggs are constant. **5** The local atmospheric pressure is 1 atm.

Properties The properties of the eggs are given to $\rho = 67.4 \text{ lbm/ft}^3$ and $c_p = 0.80 \text{ Btu/lbm}\cdot^\circ\text{F}$. The specific heat of air at room temperature $c_p = 0.24 \text{ Btu/lbm}\cdot^\circ\text{F}$ (Table A-2E). The gas constant of air is $R = 0.3704 \text{ psia}\cdot\text{ft}^3/\text{lbm}\cdot\text{R}$ (Table A-1E).

Analysis (a) Noting that eggs are cooled at a rate of 10,000 eggs per hour, eggs can be considered to flow steadily through the cooling section at a mass flow rate of

$$\dot{m}_{\text{egg}} = (10,000 \text{ eggs/h})(0.14 \text{ lbm/egg}) = 1400 \text{ lbm/h} = 0.3889 \text{ lbm/s}$$

Taking the egg flow stream in the cooler as the system, the energy balance for steadily flowing eggs can be expressed in the rate form as

$$\underbrace{\dot{E}_{\text{in}} - \dot{E}_{\text{out}}}_{\text{Rate of net energy transfer by heat, work, and mass}} = \underbrace{\Delta \dot{E}_{\text{system}}}_{\text{Rate of change in internal, kinetic, potential, etc. energies}} \stackrel{\text{no (steady)}}{=} 0$$

$$\dot{E}_{\text{in}} = \dot{E}_{\text{out}}$$

$$\dot{m}h_1 = \dot{Q}_{\text{out}} + \dot{m}h_2 \quad (\text{since } \Delta ke \cong \Delta pe \cong 0)$$

$$\dot{Q}_{\text{out}} = \dot{Q}_{\text{egg}} = \dot{m}_{\text{egg}} c_p (T_1 - T_2)$$

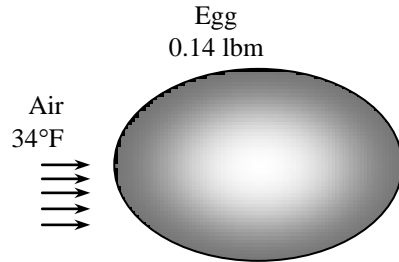

Then the rate of heat removal from the eggs as they are cooled from 90°F to 50°F at this rate becomes

$$\dot{Q}_{\text{egg}} = (\dot{m} c_p \Delta T)_{\text{egg}} = (1400 \text{ lbm/h})(0.80 \text{ Btu/lbm}\cdot^\circ\text{F})(90 - 50)^\circ\text{F} = \mathbf{44,800 \text{ Btu/h}}$$

(b) All the heat released by the eggs is absorbed by the refrigerated air since heat transfer through the walls of cooler is negligible, and the temperature rise of air is not to exceed 10°F. The minimum mass flow and volume flow rates of air are determined to be

$$\dot{m}_{\text{air}} = \frac{\dot{Q}_{\text{air}}}{(c_p \Delta T)_{\text{air}}} = \frac{44,800 \text{ Btu/h}}{(0.24 \text{ Btu/lbm}\cdot^\circ\text{F})(10^\circ\text{F})} = 18,667 \text{ lbm/h}$$

$$\rho_{\text{air}} = \frac{P}{RT} = \frac{14.7 \text{ psia}}{(0.3704 \text{ psia}\cdot\text{ft}^3/\text{lbm}\cdot\text{R})(34 + 460)\text{R}} = 0.0803 \text{ lbm/ft}^3$$

$$\dot{V}_{\text{air}} = \frac{\dot{m}_{\text{air}}}{\rho_{\text{air}}} = \frac{18,667 \text{ lbm/h}}{0.0803 \text{ lbm/ft}^3} = \mathbf{232,500 \text{ ft}^3/\text{h}}$$

5-156 Glass bottles are washed in hot water in an uncovered rectangular glass washing bath. The rates of heat and water mass that need to be supplied to the water are to be determined.

Assumptions **1** Steady operating conditions exist. **2** The entire water body is maintained at a uniform temperature of 50°C. **3** Heat losses from the outer surfaces of the bath are negligible. **4** Water is an incompressible substance with constant properties.

Properties The specific heat of water at room temperature is $c_p = 4.18 \text{ kJ/kg}\cdot^\circ\text{C}$. Also, the specific heat of glass is $0.80 \text{ kJ/kg}\cdot^\circ\text{C}$ (Table A-3).

Analysis (a) The mass flow rate of glass bottles through the water bath in steady operation is

$$\dot{m}_{\text{bottle}} = m_{\text{bottle}} \times \text{Bottle flow rate} = (0.150 \text{ kg/bottle})(450/60 \text{ bottles/s}) = 1.125 \text{ kg/s}$$

Taking the bottle flow section as the system, which is a steady-flow control volume, the energy balance for this steady-flow system can be expressed in the rate form as

$$\underbrace{\dot{E}_{\text{in}} - \dot{E}_{\text{out}}}_{\substack{\text{Rate of net energy transfer} \\ \text{by heat, work, and mass}}} = \underbrace{\Delta \dot{E}_{\text{system}}}_{\substack{\text{Rate of change in internal, kinetic,} \\ \text{potential, etc. energies}}} \stackrel{\text{no (steady)}}{=} 0$$

$$\dot{E}_{\text{in}} = \dot{E}_{\text{out}}$$

$$\dot{Q}_{\text{in}} + \dot{m}h_1 = \dot{m}h_2 \quad (\text{since } \Delta ke \cong \Delta pe \cong 0)$$

$$\dot{Q}_{\text{in}} = \dot{Q}_{\text{bottle}} = \dot{m}_{\text{water}} c_p (T_2 - T_1)$$

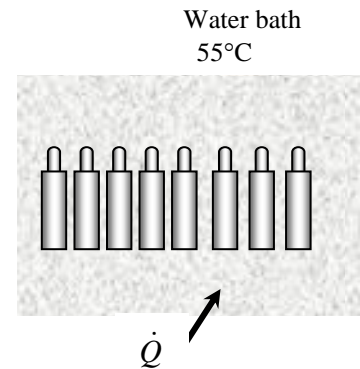

Then the rate of heat removal by the bottles as they are heated from 20 to 55°C is

$$\dot{Q}_{\text{bottle}} = \dot{m}_{\text{bottle}} c_p \Delta T = (1.125 \text{ kg/s})(0.8 \text{ kJ/kg}\cdot^\circ\text{C})(50 - 20)^\circ\text{C} = 27 \text{ kW}$$

The amount of water removed by the bottles is

$$\begin{aligned} \dot{m}_{\text{water, out}} &= (\text{Flow rate of bottles})(\text{Water removed per bottle}) \\ &= (450 \text{ bottles/min})(0.0002 \text{ g/bottle}) = 90 \text{ g/min} = \mathbf{0.0015 \text{ kg/s}} \end{aligned}$$

Noting that the water removed by the bottles is made up by fresh water entering at 15°C, the rate of heat removal by the water that sticks to the bottles is

$$\dot{Q}_{\text{water removed}} = \dot{m}_{\text{water removed}} c_p \Delta T = (0.0015 \text{ kg/s})(4.18 \text{ kJ/kg}\cdot^\circ\text{C})(50 - 15)^\circ\text{C} = 0.2195 \text{ kW}$$

Therefore, the total amount of heat removed by the wet bottles is

$$\dot{Q}_{\text{total, removed}} = \dot{Q}_{\text{glass removed}} + \dot{Q}_{\text{water removed}} = 27 + 0.2195 = \mathbf{27.22 \text{ kW}}$$

Discussion In practice, the rates of heat and water removal will be much larger since the heat losses from the tank and the moisture loss from the open surface are not considered.

5-157 Dough is made with refrigerated water in order to absorb the heat of hydration and thus to control the temperature rise during kneading. The temperature to which the city water must be cooled before mixing with flour is to be determined to avoid temperature rise during kneading.

Assumptions **1** Steady operating conditions exist. **2** The dough is at uniform temperatures before and after cooling. **3** The kneading section is well-insulated. **4** The properties of water and dough are constant.

Properties The specific heats of the flour and the water are given to be 1.76 and 4.18 kJ/kg·°C, respectively. The heat of hydration of dough is given to be 15 kJ/kg.

Analysis It is stated that 2 kg of flour is mixed with 1 kg of water, and thus 3 kg of dough is obtained from each kg of water. Also, 15 kJ of heat is released for each kg of dough kneaded, and thus $3 \times 15 = 45$ kJ of heat is released from the dough made using 1 kg of water.

Taking the cooling section of water as the system, which is a steady-flow control volume, the energy balance for this steady-flow system can be expressed in the rate form as

$$\underbrace{\dot{E}_{in} - \dot{E}_{out}}_{\text{Rate of net energy transfer by heat, work, and mass}} = \underbrace{\Delta \dot{E}_{system} \overset{\approx 0 \text{ (steady)}}{}}_{\text{Rate of change in internal, kinetic, potential, etc. energies}} = 0$$

$$\dot{E}_{in} = \dot{E}_{out}$$

$$\dot{m}h_1 = \dot{Q}_{out} + \dot{m}h_2 \quad (\text{since } \Delta ke \cong \Delta pe \cong 0)$$

$$\dot{Q}_{out} = \dot{Q}_{water} = \dot{m}_{water}c_p(T_1 - T_2)$$

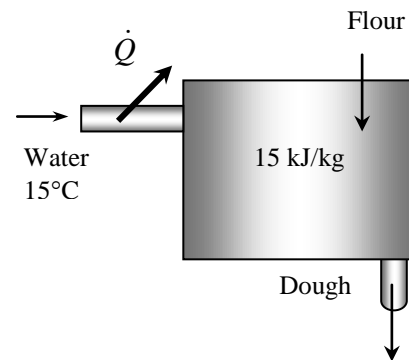

In order for water to absorb all the heat of hydration and end up at a temperature of 15°C, its temperature before entering the mixing section must be reduced to

$$Q_{in} = Q_{dough} = mc_p(T_2 - T_1) \rightarrow T_1 = T_2 - \frac{Q}{mc_p} = 15^\circ\text{C} - \frac{45 \text{ kJ}}{(1 \text{ kg})(4.18 \text{ kJ/kg}\cdot^\circ\text{C})} = \mathbf{4.2^\circ\text{C}}$$

That is, the water must be precooled to 4.2°C before mixing with the flour in order to absorb the entire heat of hydration.

5-158 Long aluminum wires are extruded at a velocity of 8 m/min, and are exposed to atmospheric air. The rate of heat transfer from the wire is to be determined.

Assumptions 1 Steady operating conditions exist. 2 The thermal properties of the wire are constant.

Properties The properties of aluminum are given to be $\rho = 2702 \text{ kg/m}^3$ and $c_p = 0.896 \text{ kJ/kg}\cdot^\circ\text{C}$.

Analysis The mass flow rate of the extruded wire through the air is

$$\dot{m} = \rho \dot{V} = \rho(\pi r_0^2) \mathcal{V} = (2702 \text{ kg/m}^3)\pi(0.0025 \text{ m})^2 (8 \text{ m/min}) = 0.4244 \text{ kg/min} = 0.007074 \text{ kg/s}$$

Taking the volume occupied by the extruded wire as the system, which is a steady-flow control volume, the energy balance for this steady-flow system can be expressed in the rate form as

$$\begin{aligned} \underbrace{\dot{E}_{\text{in}} - \dot{E}_{\text{out}}}_{\text{Rate of net energy transfer by heat, work, and mass}} &= \underbrace{\Delta \dot{E}_{\text{system}}}_{\text{Rate of change in internal, kinetic, potential, etc. energies}} \stackrel{\text{no (steady)}}{=} 0 \\ \dot{E}_{\text{in}} &= \dot{E}_{\text{out}} \\ \dot{m}h_1 &= \dot{Q}_{\text{out}} + \dot{m}h_2 \quad (\text{since } \Delta ke \cong \Delta pe \cong 0) \\ \dot{Q}_{\text{out}} &= \dot{Q}_{\text{wire}} = \dot{m}_{\text{wire}} c_p (T_1 - T_2) \end{aligned}$$

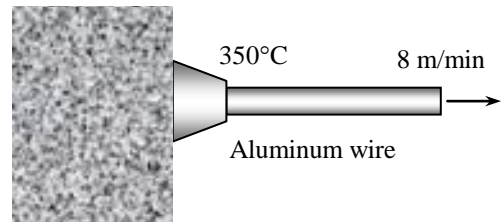

Then the rate of heat transfer from the wire to the air becomes

$$\dot{Q} = \dot{m} c_p [T(t) - T_\infty] = (0.007074 \text{ kg/s})(0.896 \text{ kJ/kg}\cdot^\circ\text{C})(350 - 50)^\circ\text{C} = \mathbf{1.90 \text{ kW}}$$

5-159 Long copper wires are extruded at a velocity of 8 m/min, and are exposed to atmospheric air. The rate of heat transfer from the wire is to be determined.

Assumptions 1 Steady operating conditions exist. 2 The thermal properties of the wire are constant.

Properties The properties of copper are given to be $\rho = 8950 \text{ kg/m}^3$ and $c_p = 0.383 \text{ kJ/kg}\cdot^\circ\text{C}$.

Analysis The mass flow rate of the extruded wire through the air is

$$\dot{m} = \rho \dot{V} = \rho(\pi r_0^2) \mathcal{V} = (8950 \text{ kg/m}^3)\pi(0.0025 \text{ m})^2 (8 / 60 \text{ m/s}) = 0.02343 \text{ kg/s}$$

Taking the volume occupied by the extruded wire as the system, which is a steady-flow control volume, the energy balance for this steady-flow system can be expressed in the rate form as

$$\begin{aligned} \underbrace{\dot{E}_{\text{in}} - \dot{E}_{\text{out}}}_{\text{Rate of net energy transfer by heat, work, and mass}} &= \underbrace{\Delta \dot{E}_{\text{system}}}_{\text{Rate of change in internal, kinetic, potential, etc. energies}} \stackrel{\text{no (steady)}}{=} 0 \\ \dot{E}_{\text{in}} &= \dot{E}_{\text{out}} \\ \dot{m}h_1 &= \dot{Q}_{\text{out}} + \dot{m}h_2 \quad (\text{since } \Delta ke \cong \Delta pe \cong 0) \\ \dot{Q}_{\text{out}} &= \dot{Q}_{\text{wire}} = \dot{m}_{\text{wire}} c_p (T_1 - T_2) \end{aligned}$$

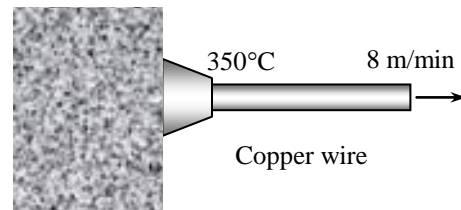

Then the rate of heat transfer from the wire to the air becomes

$$\dot{Q} = \dot{m} c_p [T(t) - T_\infty] = (0.02343 \text{ kg/s})(0.383 \text{ kJ/kg}\cdot^\circ\text{C})(350 - 50)^\circ\text{C} = \mathbf{2.69 \text{ kW}}$$

5-160E Steam is mixed with water steadily in an adiabatic device. The temperature of the water leaving this device is to be determined.

Assumptions 1 This is a steady-flow process since there is no change with time. **2** Kinetic and potential energy changes are negligible. **3** There are no work and heat interactions. **4** There is no heat transfer between the mixing device and the surroundings.

Analysis We take the mixing device as the system, which is a control volume. The energy balance for this steady-flow system can be expressed in the rate form as

$$\underbrace{\dot{E}_{\text{in}} - \dot{E}_{\text{out}}}_{\text{Rate of net energy transfer by heat, work, and mass}} = \underbrace{\dot{\Delta E}_{\text{system}}^{\text{no (steady)}}}_{\text{Rate of change in internal, kinetic, potential, etc. energies}} = 0$$

$$\dot{E}_{\text{in}} = \dot{E}_{\text{out}}$$

$$\dot{m}_1 h_1 + \dot{m}_2 h_2 = \dot{m}_3 h_3$$

From a mass balance

$$\dot{m}_3 = \dot{m}_1 + \dot{m}_2 = 0.05 + 1 = 1.05 \text{ lbm/s}$$

The enthalpies of steam and water are (Table A-6E and A-4E)

$$\left. \begin{array}{l} P_1 = 80 \text{ psia} \\ T_1 = 400^\circ\text{F} \end{array} \right\} h_1 = 1230.8 \text{ Btu/lbm}$$

$$\left. \begin{array}{l} P_2 = 80 \text{ psia} \\ T_2 = 60^\circ\text{F} \end{array} \right\} h_2 \cong h_f @ 60^\circ\text{F} = 28.08 \text{ Btu/lbm}$$

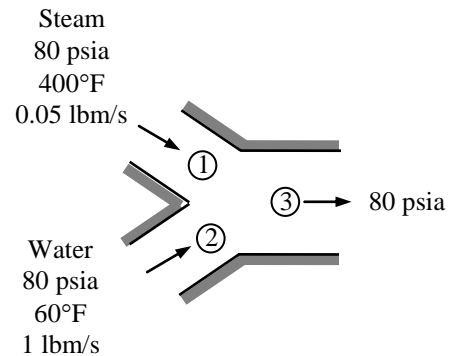

Substituting into the energy balance equation solving for the exit enthalpy gives

$$h_3 = \frac{\dot{m}_1 h_1 + \dot{m}_2 h_2}{\dot{m}_3} = \frac{(0.05 \text{ lbm/s})(1230.8 \text{ Btu/lbm}) + (1 \text{ lbm/s})(28.08 \text{ Btu/lbm})}{1.05 \text{ lbm/s}} = 85.35 \text{ Btu/lbm}$$

At the exit state $P_3 = 80 \text{ psia}$ and $h_3 = 85.35 \text{ kJ/kg}$. An investigation of Table A-5E reveals that this is compressed liquid state. Approximating this state as saturated liquid at the specified temperature, the temperature may be determined from Table A-4E to be

$$\left. \begin{array}{l} P_3 = 80 \text{ psia} \\ h_3 = 85.35 \text{ Btu/lbm} \end{array} \right\} T_3 \cong T_f @ h=85.35 \text{ Btu/lbm} = \mathbf{117.3^\circ\text{F}}$$

Discussion The exact answer is determined at the compressed liquid state using EES to be 117.1°F , indicating that the saturated liquid approximation is a reasonable one.

5-161 A constant-pressure R-134a vapor separation unit separates the liquid and vapor portions of a saturated mixture into two separate outlet streams. The flow power needed to operate this unit and the mass flow rate of the two outlet streams are to be determined.

Assumptions 1 This is a steady-flow process since there is no change with time. **2** Kinetic and potential energy changes are negligible. **3** There are no work and heat interactions.

Analysis The specific volume at the inlet is (Table A-12)

$$\left. \begin{array}{l} P_1 = 320 \text{ kPa} \\ x_1 = 0.55 \end{array} \right\} \nu_1 = \nu_f + x_1(\nu_g - \nu_f) = 0.0007771 + (0.55)(0.06368 - 0.0007771) = 0.03537 \text{ m}^3/\text{kg}$$

The mass flow rate at the inlet is then

$$\dot{m}_1 = \frac{\dot{V}_1}{\nu_1} = \frac{0.006 \text{ m}^3/\text{s}}{0.03537 \text{ m}^3/\text{kg}} = 0.1696 \text{ kg/s}$$

For each kg of mixture processed, 0.55 kg of vapor are processed. Therefore,

$$\dot{m}_2 = 0.55\dot{m}_1 = 0.55 \times 0.1696 = \mathbf{0.09329 \text{ kg/s}}$$

$$\dot{m}_3 = \dot{m}_1 - \dot{m}_2 = 0.45\dot{m}_1 = 0.45 \times 0.1696 = \mathbf{0.07633 \text{ kg/s}}$$

The flow power for this unit is

$$\begin{aligned} \dot{W}_{\text{flow}} &= \dot{m}_2 P_2 \nu_2 + \dot{m}_3 P_3 \nu_3 - \dot{m}_1 P_1 \nu_1 \\ &= (0.09329 \text{ kg/s})(320 \text{ kPa})(0.06368 \text{ m}^3/\text{kg}) + (0.07633 \text{ kg/s})(320 \text{ kPa})(0.0007771 \text{ m}^3/\text{kg}) \\ &\quad - (0.1696 \text{ kg/s})(320 \text{ kPa})(0.03537 \text{ m}^3/\text{kg}) \\ &= \mathbf{0 \text{ kW}} \end{aligned}$$

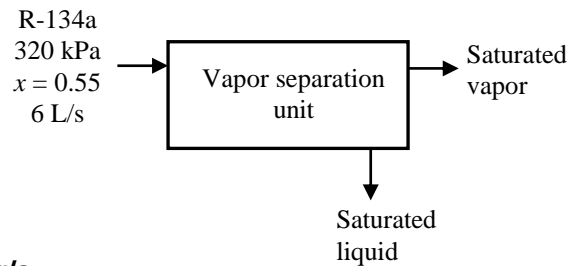

5-162 Two identical buildings in Los Angeles and Denver have the same infiltration rate. The ratio of the heat losses by infiltration at the two cities under identical conditions is to be determined.

Assumptions 1 Both buildings are identical and both are subjected to the same conditions except the atmospheric conditions. 2 Air is an ideal gas with constant specific heats at room temperature. 3 Steady flow conditions exist.

Analysis We can view infiltration as a steady stream of air that is heated as it flows in an imaginary duct passing through the building. The energy balance for this imaginary steady-flow system can be expressed in the rate form as

$$\underbrace{\dot{E}_{\text{in}} - \dot{E}_{\text{out}}}_{\text{Rate of net energy transfer by heat, work, and mass}} = \underbrace{\Delta \dot{E}_{\text{system}}}_{\text{Rate of change in internal, kinetic, potential, etc. energies}} \stackrel{\text{no (steady)}}{=} 0$$

$$\dot{E}_{\text{in}} = \dot{E}_{\text{out}}$$

$$\dot{Q}_{\text{in}} + \dot{m}h_1 = \dot{m}h_2 \quad (\text{since } \Delta ke \cong \Delta pe \cong 0)$$

$$\dot{Q}_{\text{in}} = \dot{m}c_p(T_2 - T_1) = \rho \dot{V}c_p(T_2 - T_1)$$

Los Angeles: 101 kPa
Denver: 83 kPa



Then the sensible infiltration heat loss (heat gain for the infiltrating air) can be expressed

$$\dot{Q}_{\text{infiltration}} = \dot{m}_{\text{air}}c_p(T_i - T_o) = \rho_{o, \text{air}}(\text{ACH})(V_{\text{building}})c_p(T_i - T_o)$$

where *ACH* is the infiltration volume rate in *air changes per hour*. Therefore, the infiltration heat loss is proportional to the density of air, and thus the ratio of infiltration heat losses at the two cities is simply the densities of outdoor air at those cities,

$$\begin{aligned} \text{Infiltration heat loss ratio} &= \frac{\dot{Q}_{\text{infiltration, Los Angeles}}}{\dot{Q}_{\text{infiltration, Denver}}} = \frac{\rho_{o, \text{air, Los Angeles}}}{\rho_{o, \text{air, Denver}}} \\ &= \frac{(P_o/RT_o)_{\text{Los Angeles}}}{(P_o/RT_o)_{\text{Denver}}} = \frac{P_{o, \text{Los Angeles}}}{P_{o, \text{Denver}}} = \frac{101 \text{ kPa}}{83 \text{ kPa}} = \mathbf{1.22} \end{aligned}$$

Therefore, the infiltration heat loss in Los Angeles will be 22% higher than that in Denver under identical conditions.

5-163E A study quantifies the cost and benefits of enhancing IAQ by increasing the building ventilation. The net monetary benefit of installing an enhanced IAQ system to the employer per year is to be determined.

Assumptions The analysis in the report is applicable to this work place.

Analysis The report states that enhancing IAQ increases the productivity of a person by \$90 per year, and decreases the cost of the respiratory illnesses by \$39 a year while increasing the annual energy consumption by \$6 and the equipment cost by about \$4 a year. The net monetary benefit of installing an enhanced IAQ system to the employer per year is determined by adding the benefits and subtracting the costs to be

$$\text{Net benefit} = \text{Total benefits} - \text{total cost} = (90+39) - (6+4) = \$119/\text{year} \quad (\text{per person})$$

The total benefit is determined by multiplying the benefit per person by the number of employees,

$$\text{Total net benefit} = \text{No. of employees} \times \text{Net benefit per person} = 120 \times \$119/\text{year} = \mathbf{\$14,280/\text{year}}$$

Discussion Note that the unseen savings in productivity and reduced illnesses can be very significant when they are properly quantified.

5-164 The ventilating fan of the bathroom of an electrically heated building in San Francisco runs continuously. The amount and cost of the heat “vented out” per month in winter are to be determined.

Assumptions 1 We take the atmospheric pressure to be 1 atm = 101.3 kPa since San Francisco is at sea level. **2** The building is maintained at 22°C at all times. **3** The infiltrating air is heated to 22°C before it exfiltrates. **4** Air is an ideal gas with constant specific heats at room temperature. **5** Steady flow conditions exist.

Properties The gas constant of air is $R = 0.287 \text{ kPa}\cdot\text{m}^3/\text{kg}\cdot\text{K}$ (Table A-1). The specific heat of air at room temperature is $c_p = 1.005 \text{ kJ}/\text{kg}\cdot^\circ\text{C}$ (Table A-2).

Analysis The density of air at the indoor conditions of 1 atm and 22°C is

$$\rho_o = \frac{P_o}{RT_o} = \frac{(101.3 \text{ kPa})}{(0.287 \text{ kPa}\cdot\text{m}^3/\text{kg}\cdot\text{K})(22 + 273 \text{ K})} = 1.197 \text{ kg}/\text{m}^3$$

Then the mass flow rate of air vented out becomes

$$\dot{m}_{\text{air}} = \rho \dot{V}_{\text{air}} = (1.197 \text{ kg}/\text{m}^3)(0.030 \text{ m}^3/\text{s}) = 0.03590 \text{ kg}/\text{s}$$

We can view infiltration as a steady stream of air that is heated as it flows in an imaginary duct passing through the house. The energy balance for this imaginary steady-flow system can be expressed in the rate form as

$$\underbrace{\dot{E}_{\text{in}} - \dot{E}_{\text{out}}}_{\text{Rate of net energy transfer by heat, work, and mass}} = \underbrace{\Delta \dot{E}_{\text{system}}}_{\text{Rate of change in internal, kinetic, potential, etc. energies}} \stackrel{\text{no (steady)}}{=} 0$$

$$\dot{E}_{\text{in}} = \dot{E}_{\text{out}}$$

$$\dot{Q}_{\text{in}} + \dot{m}h_1 = \dot{m}h_2 \quad (\text{since } \Delta ke \cong \Delta pe \cong 0)$$

$$\dot{Q}_{\text{in}} = \dot{m}c_p(T_2 - T_1)$$

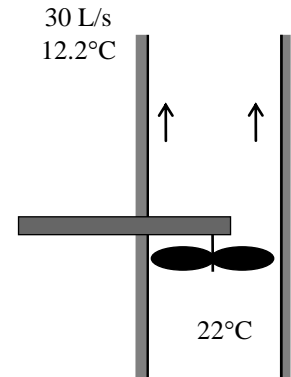

Noting that the indoor air vented out at 22°C is replaced by infiltrating outdoor air at 12.2°C, the sensible infiltration heat loss (heat gain for the infiltrating air) due to venting by fans can be expressed

$$\begin{aligned} \dot{Q}_{\text{loss by fan}} &= \dot{m}_{\text{air}} c_p (T_{\text{indoors}} - T_{\text{outdoors}}) \\ &= (0.0359 \text{ kg}/\text{s})(1.005 \text{ kJ}/\text{kg}\cdot^\circ\text{C})(22 - 12.2)^\circ\text{C} = 0.3536 \text{ kJ}/\text{s} = 0.3536 \text{ kW} \end{aligned}$$

Then the amount and cost of the heat “vented out” per month (1 month = 30×24 = 720 h) becomes

$$\begin{aligned} \text{Energy loss} &= \dot{Q}_{\text{loss by fan}} \Delta t = (0.3536 \text{ kW})(720 \text{ h}/\text{month}) = \mathbf{254.6 \text{ kWh}/\text{month}} \\ \text{Money loss} &= (\text{Energy loss})(\text{Unit cost of energy}) = (254.6 \text{ kWh}/\text{month})(\$0.12/\text{kWh}) = \mathbf{\$22.9/\text{month}} \end{aligned}$$

Discussion Note that the energy and money loss associated with ventilating fans can be very significant. Therefore, ventilating fans should be used with care.

5-165E The relationships between the mass flow rate and the time for the inflation and deflation of an air bag are given. The volume of this bag as a function of time are to be plotted.

Assumptions Uniform flow exists at the inlet and outlet.

Properties The specific volume of air during inflation and deflation are given to be 15 and 13 ft³/lbm, respectively.

Analysis The volume of the airbag at any time is given by

$$V(t) = \int_{\text{in flow time}} (\dot{m}v)_{\text{in}} dt - \int_{\text{outflow time}} (\dot{m}v)_{\text{out}} dt$$

Applying at different time periods as given in problem statement give

$$V(t) = \int_0^t (15 \text{ ft}^3/\text{lbm}) \frac{20 \text{ lbm/s}}{10 \text{ ms}} \left(\frac{1 \text{ s}}{1000 \text{ ms}} \right) t dt \quad 0 \leq t \leq 10 \text{ ms}$$

$$V(t) = \int_0^t 0.015t^2 \text{ ft}^3/\text{ms}^2 \quad 0 \leq t \leq 10 \text{ ms}$$

$$V(t) = V(10 \text{ ms}) + \int_{10 \text{ ms}}^t (15 \text{ ft}^3/\text{lbm})(20 \text{ lbm/s}) \left(\frac{1 \text{ s}}{1000 \text{ ms}} \right) t dt \quad 10 < t \leq 12 \text{ ms}$$

$$V(t) = V(10 \text{ ms}) + 0.03 \text{ ft}^3/\text{ms}^2 (t - 10 \text{ ms}) \quad 10 < t \leq 12 \text{ ms}$$

$$V(t) = V(12 \text{ ms}) + 0.03 \text{ ft}^3/\text{ms}^2 (t - 12 \text{ ms})$$

$$- \int_{12 \text{ ms}}^t (13 \text{ ft}^3/\text{lbm}) \frac{16 \text{ lbm/s}}{(30 - 12) \text{ ms}} \left(\frac{1 \text{ s}}{1000 \text{ ms}} \right) (t - 12 \text{ ms}) dt \quad 12 < t \leq 25 \text{ ms}$$

$$V(t) = V(12 \text{ ms}) + 0.03 \text{ ft}^3/\text{ms}^2 (t - 12 \text{ ms})$$

$$- \int_{12 \text{ ms}}^t 0.011556 \text{ ft}^3/\text{ms}^2 (t - 12 \text{ ms}) dt \quad 12 < t \leq 25 \text{ ms}$$

$$V(t) = V(12 \text{ ms}) + 0.03 \text{ ft}^3/\text{ms}^2 (t - 12 \text{ ms})$$

$$- \frac{0.011556}{2} (t^2 - 144 \text{ ms}^2) + 0.13867(t - 12 \text{ ms}) \quad 12 < t \leq 25 \text{ ms}$$

$$V(t) = V(25 \text{ ms}) - \frac{0.011556}{2} (t^2 - 625 \text{ ms}^2) + 0.13867(t - 25 \text{ ms}) \quad 25 < t \leq 30 \text{ ms}$$

$$V(t) = V(30 \text{ ms}) - \int_{12 \text{ ms}}^t (13 \text{ ft}^3/\text{lbm})(16 \text{ lbm/s}) \left(\frac{1 \text{ s}}{1000 \text{ ms}} \right) dt \quad 30 < t \leq 50 \text{ ms}$$

$$V(t) = V(30 \text{ ms}) - (0.208 \text{ ft}^3/\text{ms})(t - 30 \text{ ms}) \quad 30 < t \leq 50 \text{ ms}$$

The results with some suitable time intervals are

Time, ms	V, ft ³
0	0
2	0.06
4	0.24
6	0.54
8	0.96
10	1.50
12	2.10
15	2.95
20	4.13
25	5.02
27	4.70
30	4.13
40	2.05
46	0.80
49.85	0

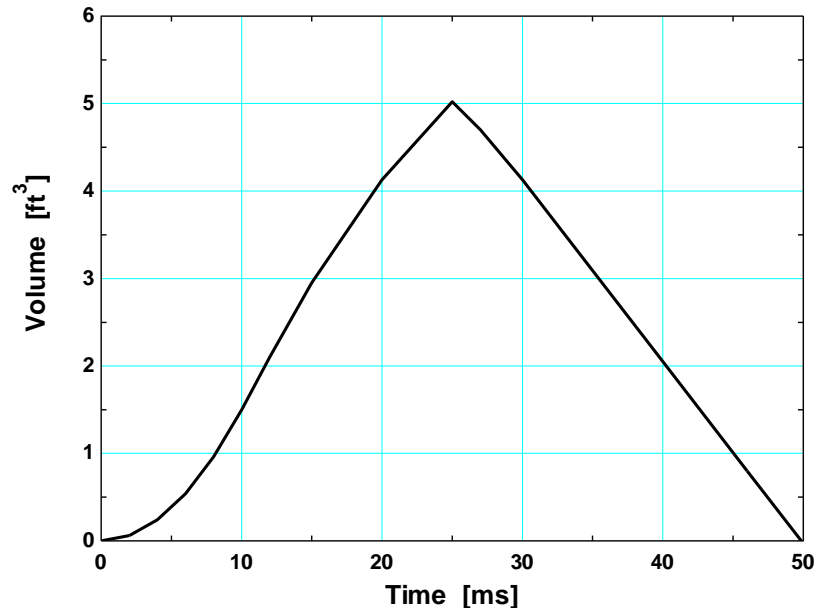

Alternative solution

The net volume flow rate is obtained from

$$\dot{V} = (\dot{m}\nu)_{\text{in}} - (\dot{m}\nu)_{\text{out}}$$

which is sketched on the figure below. The volume of the airbag is given by

$$V = \int \dot{V} dt$$

The results of a graphical interpretation of the volume is also given in the figure below. Note that the evaluation of the above integral is simply the area under the process curve.

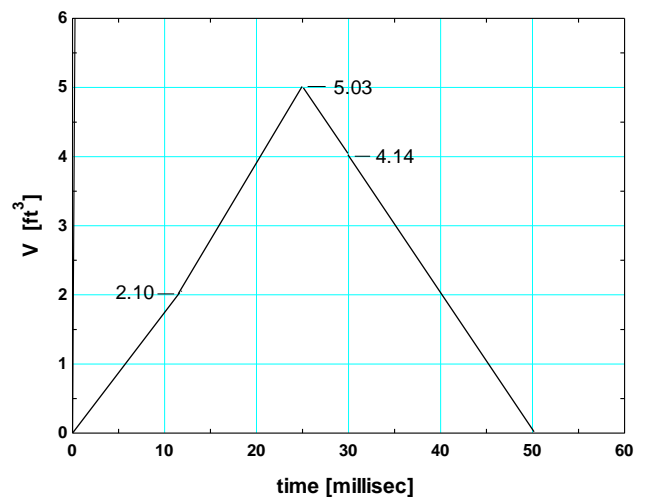
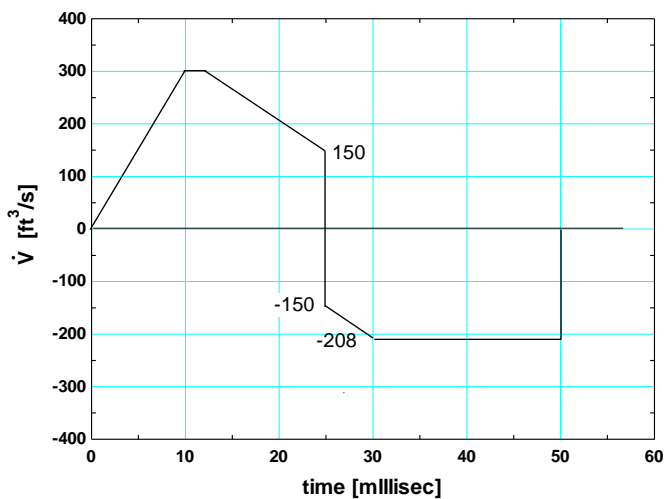

5-166 Outdoors air at -5°C and 95 kPa enters the building at a rate of 60 L/s while the indoors is maintained at 25°C . The rate of sensible heat loss from the building due to infiltration is to be determined.

Assumptions **1** The house is maintained at 25°C at all times. **2** The latent heat load is negligible. **3** The infiltrating air is heated to 25°C before it exfiltrates. **4** Air is an ideal gas with constant specific heats at room temperature. **5** The changes in kinetic and potential energies are negligible. **6** Steady flow conditions exist.

Properties The gas constant of air is $R = 0.287\text{ kPa}\cdot\text{m}^3/\text{kg}\cdot\text{K}$. The specific heat of air at room temperature is $c_p = 1.005\text{ kJ/kg}\cdot^{\circ}\text{C}$ (Table A-2).

Analysis The density of air at the outdoor conditions is

$$\rho_o = \frac{P_o}{RT_o} = \frac{95\text{ kPa}}{(0.287\text{ kPa}\cdot\text{m}^3/\text{kg}\cdot\text{K})(-5 + 273\text{ K})} = 1.235\text{ kg/m}^3$$

We can view infiltration as a steady stream of air that is heated as it flows in an imaginary duct passing through the building. The energy balance for this imaginary steady-flow system can be expressed in the rate form as

$$\underbrace{\dot{E}_{\text{in}} - \dot{E}_{\text{out}}}_{\text{Rate of net energy transfer by heat, work, and mass}} = \underbrace{\Delta\dot{E}_{\text{system}}}_{\text{Rate of change in internal, kinetic, potential, etc. energies}} \stackrel{\approx 0 \text{ (steady)}}{=} 0$$

$$\dot{E}_{\text{in}} = \dot{E}_{\text{out}}$$

$$\dot{Q}_{\text{in}} + \dot{m}h_1 = \dot{m}h_2 \quad (\text{since } \Delta ke \cong \Delta pe \cong 0)$$

$$\dot{Q}_{\text{in}} = \dot{m}c_p(T_2 - T_1)$$

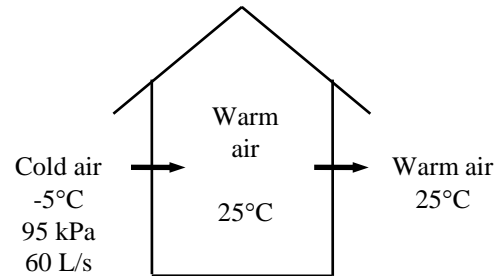

Then the sensible infiltration heat load corresponding to an infiltration rate of 60 L/s becomes

$$\begin{aligned} \dot{Q}_{\text{infiltration}} &= \rho_o \dot{V}_{\text{air}} c_p (T_i - T_o) \\ &= (1.235\text{ kg/m}^3)(0.060\text{ m}^3/\text{s})(1.005\text{ kJ/kg}\cdot^{\circ}\text{C})[25 - (-5)]^{\circ}\text{C} \\ &= \mathbf{2.23\text{ kW}} \end{aligned}$$

Therefore, sensible heat will be lost at a rate of 2.23 kJ/s due to infiltration.

5-167 The average air velocity in the circular duct of an air-conditioning system is not to exceed 8 m/s. If the fan converts 80 percent of the electrical energy into kinetic energy, the size of the fan motor needed and the diameter of the main duct are to be determined.

Assumptions **1** This is a steady-flow process since there is no change with time at any point and thus $\Delta m_{CV} = 0$ and $\Delta E_{CV} = 0$. **2** The inlet velocity is negligible, $V_1 \cong 0$. **3** There are no heat and work interactions other than the electrical power consumed by the fan motor. **4** Air is an ideal gas with constant specific heats at room temperature.

Properties The density of air is given to be $\rho = 1.20 \text{ kg/m}^3$. The constant pressure specific heat of air at room temperature is $c_p = 1.005 \text{ kJ/kg}\cdot^\circ\text{C}$ (Table A-2).

Analysis We take the *fan-motor assembly* as the system. This is a *control volume* since mass crosses the system boundary during the process. We note that there is only one inlet and one exit, and thus $\dot{m}_1 = \dot{m}_2 = \dot{m}$. The change in the kinetic energy of air as it is accelerated from zero to 8 m/s at a rate of $130 \text{ m}^3/\text{min}$ is

$$\dot{m} = \rho \dot{V} = (1.20 \text{ kg/m}^3)(130 \text{ m}^3/\text{min}) = 156 \text{ kg/min} = 2.6 \text{ kg/s}$$

$$\Delta \dot{K}E = \dot{m} \frac{V_2^2 - V_1^2}{2} = (2.6 \text{ kg/s}) \frac{(8 \text{ m/s})^2 - 0}{2} \left(\frac{1 \text{ kJ/kg}}{1000 \text{ m}^2/\text{s}^2} \right) = 0.0832 \text{ kW}$$

It is stated that this represents 80% of the electrical energy consumed by the motor. Then the total electrical power consumed by the motor is determined to be

$$0.7 \dot{W}_{\text{motor}} = \Delta \dot{K}E \rightarrow \dot{W}_{\text{motor}} = \frac{\Delta \dot{K}E}{0.8} = \frac{0.0832 \text{ kW}}{0.8} = \mathbf{0.104 \text{ kW}}$$

The diameter of the main duct is

$$\dot{V} = VA = V(\pi D^2 / 4) \rightarrow D = \sqrt{\frac{4\dot{V}}{\pi V}} = \sqrt{\frac{4(130 \text{ m}^3 / \text{min}) \left(\frac{1 \text{ min}}{60 \text{ s}} \right)}{\pi(8 \text{ m/s})}} = \mathbf{0.587 \text{ m}}$$

Therefore, the motor should have a rated power of at least 0.104 kW, and the diameter of the duct should be at least 58.7 cm

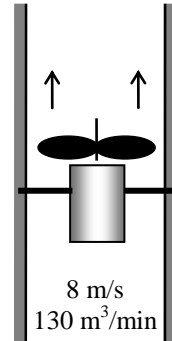

5-168 The maximum flow rate of a standard shower head can be reduced from 13.3 to 10.5 L/min by switching to low-flow shower heads. The ratio of the hot-to-cold water flow rates and the amount of electricity saved by a family of four per year by replacing the standard shower heads by the low-flow ones are to be determined.

Assumptions **1** This is a steady-flow process since there is no change with time at any point and thus $\Delta m_{CV} = 0$ and $\Delta E_{CV} = 0$. **2** The kinetic and potential energies are negligible, $ke \cong pe \cong 0$. **3** Heat losses from the system are negligible and thus $\dot{Q} \cong 0$. **4** There are no work interactions involved. **5** Showers operate at maximum flow conditions during the entire shower. **6** Each member of the household takes a 5-min shower every day. **7** Water is an incompressible substance with constant properties. **8** The efficiency of the electric water heater is 100%.

Properties The density and specific heat of water at room temperature are $\rho = 1 \text{ kg/L}$ and $c = 4.18 \text{ kJ/kg}\cdot^\circ\text{C}$ (Table A-3).

Analysis (a) We take the *mixing chamber* as the system. This is a *control volume* since mass crosses the system boundary during the process. We note that there are two inlets and one exit. The mass and energy balances for this steady-flow system can be expressed in the rate form as follows:

$$\text{Mass balance:} \quad \dot{m}_{\text{in}} - \dot{m}_{\text{out}} = \Delta \dot{m}_{\text{system}} \stackrel{\approx 0 \text{ (steady)}}{=} 0$$

$$\dot{m}_{\text{in}} = \dot{m}_{\text{out}} \rightarrow \dot{m}_1 + \dot{m}_2 = \dot{m}_3$$

$$\text{Energy balance:} \quad \underbrace{\dot{E}_{\text{in}} - \dot{E}_{\text{out}}}_{\substack{\text{Rate of net energy transfer} \\ \text{by heat, work, and mass}}} = \underbrace{\Delta \dot{E}_{\text{system}} \stackrel{\approx 0 \text{ (steady)}}{=} 0}_{\substack{\text{Rate of change in internal, kinetic,} \\ \text{potential, etc. energies}}} = 0$$

$$\dot{E}_{\text{in}} = \dot{E}_{\text{out}}$$

$$\dot{m}_1 h_1 + \dot{m}_2 h_2 = \dot{m}_3 h_3 \quad (\text{since } \dot{Q} \cong 0, \dot{W} = 0, ke \cong pe \cong 0)$$

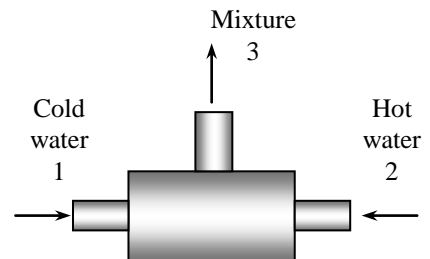

Combining the mass and energy balances and rearranging,

$$\dot{m}_1 h_1 + \dot{m}_2 h_2 = (\dot{m}_1 + \dot{m}_2) h_3$$

$$\dot{m}_2 (h_2 - h_3) = \dot{m}_1 (h_3 - h_1)$$

Then the ratio of the mass flow rates of the hot water to cold water becomes

$$\frac{\dot{m}_2}{\dot{m}_1} = \frac{h_3 - h_1}{h_2 - h_3} = \frac{c(T_3 - T_1)}{c(T_2 - T_3)} = \frac{T_3 - T_1}{T_2 - T_3} = \frac{(42 - 15)^\circ\text{C}}{(55 - 42)^\circ\text{C}} = \mathbf{2.08}$$

(b) The low-flow heads will save water at a rate of

$$\dot{V}_{\text{saved}} = [(13.3 - 10.5) \text{ L/min}](5 \text{ min/person}\cdot\text{day})(4 \text{ persons})(365 \text{ days/yr}) = 20,440 \text{ L/year}$$

$$\dot{m}_{\text{saved}} = \rho \dot{V}_{\text{saved}} = (1 \text{ kg/L})(20,440 \text{ L/year}) = 20,440 \text{ kg/year}$$

Then the energy saved per year becomes

$$\text{Energy saved} = \dot{m}_{\text{saved}} c \Delta T = (20,440 \text{ kg/year})(4.18 \text{ kJ/kg}\cdot^\circ\text{C})(42 - 15)^\circ\text{C}$$

$$= 2,307,000 \text{ kJ/year}$$

$$= \mathbf{641 \text{ kWh}} \quad (\text{since } 1 \text{ kWh} = 3600 \text{ kJ})$$

Therefore, switching to low-flow shower heads will save about 641 kWh of electricity per year.



5-169 Problem 5-168 is reconsidered. The effect of the inlet temperature of cold water on the energy saved by using the low-flow showerhead as the inlet temperature varies from 10°C to 20°C is to be investigated. The electric energy savings is to be plotted against the water inlet temperature.

Analysis The problem is solved using EES, and the results are tabulated and plotted below.

"Knowns:"

$$c_p = 4.18 \text{ [kJ/kg-K]}$$

$$\text{density} = 1 \text{ [kg/L]}$$

$$\{T_1 = 15 \text{ [C]}\}$$

$$T_2 = 55 \text{ [C]}$$

$$T_3 = 42 \text{ [C]}$$

$$V_{\text{dot_old}} = 13.3 \text{ [L/min]}$$

$$V_{\text{dot_new}} = 10.5 \text{ [L/min]}$$

$$m_{\text{dot}_1} = 1 \text{ [kg/s]} \text{ "We can set } m_{\text{dot}_1} = 1 \text{ without loss of generality."}$$

"Analysis:"

"(a) We take the mixing chamber as the system. This is a control volume since mass crosses the system boundary during the process. We note that there are two inlets and one exit. The mass and energy balances for this steady-flow system can be expressed in the rate form as follows:"

"Mass balance:"

$$m_{\text{dot_in}} - m_{\text{dot_out}} = \text{DELTA}m_{\text{dot_sys}}$$

$$\text{DELTA}m_{\text{dot_sys}} = 0$$

$$m_{\text{dot_in}} = m_{\text{dot}_1} + m_{\text{dot}_2}$$

$$m_{\text{dot_out}} = m_{\text{dot}_3}$$

"The ratio of the mass flow rates of the hot water to cold water is obtained by setting $m_{\text{dot}_1} = 1 \text{ [kg/s]}$. Then m_{dot_2} represents the ratio of $m_{\text{dot}_2}/m_{\text{dot}_1}$ "

"Energy balance:"

$$E_{\text{dot_in}} - E_{\text{dot_out}} = \text{DELTA}E_{\text{dot_sys}}$$

$$\text{DELTA}E_{\text{dot_sys}} = 0$$

$$E_{\text{dot_in}} = m_{\text{dot}_1}h_1 + m_{\text{dot}_2}h_2$$

$$E_{\text{dot_out}} = m_{\text{dot}_3}h_3$$

$$h_1 = c_p T_1$$

$$h_2 = c_p T_2$$

$$h_3 = c_p T_3$$

"(b) The low-flow heads will save water at a rate of "

$$V_{\text{dot_saved}} = (V_{\text{dot_old}} - V_{\text{dot_new}}) \text{ "L/min"} * (5 \text{ "min/person-day"}) * (4 \text{ "persons"}) * (365 \text{ "days/year"}) \text{ "[L/year]}"$$

$$m_{\text{dot_saved}} = \text{density} * V_{\text{dot_saved}} \text{ "[kg/year]}"$$

"Then the energy saved per year becomes"

$$E_{\text{dot_saved}} = m_{\text{dot_saved}} * C_P * (T_3 - T_1) \text{ "kJ/year"} * \text{convert(kJ,kWh)} \text{ "[kWh/year]}"$$

"Therefore, switching to low-flow shower heads will save about 641 kWh of electricity per year. "

$$m_{\text{ratio}} = m_{\text{dot}_2}/m_{\text{dot}_1} \text{ "Ratio of hot-to-cold water flow rates:"}$$

E_{saved} [kWh/year]	T_1 [C]
759.5	10
712	12
664.5	14
617.1	16
569.6	18
522.1	20

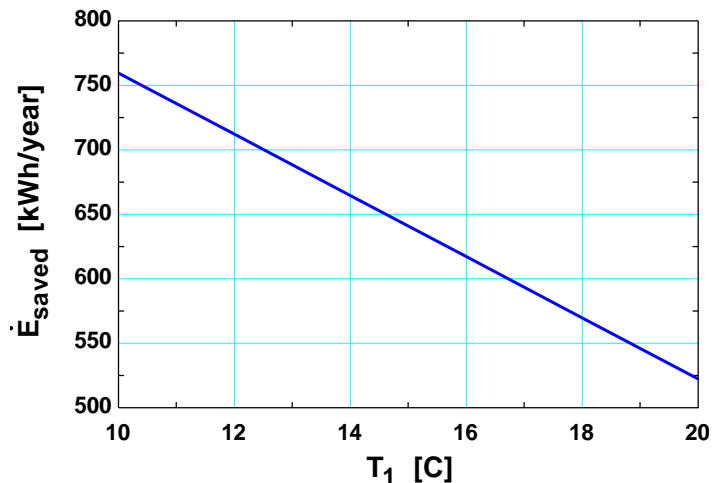

5-170 An adiabatic air compressor is powered by a direct-coupled steam turbine, which is also driving a generator. The net power delivered to the generator is to be determined.

Assumptions 1 This is a steady-flow process since there is no change with time. **2** Kinetic and potential energy changes are negligible. **3** The devices are adiabatic and thus heat transfer is negligible. **4** Air is an ideal gas with variable specific heats.

Properties From the steam tables (Tables A-4 through 6)

$$\left. \begin{array}{l} P_3 = 12.5 \text{ MPa} \\ T_3 = 500^\circ\text{C} \end{array} \right\} h_3 = 3343.6 \text{ kJ/kg}$$

and

$$\left. \begin{array}{l} P_4 = 10 \text{ kPa} \\ x_4 = 0.92 \end{array} \right\} h_4 = h_f + x_4 h_{fg} = 191.81 + (0.92)(2392.1) = 2392.5 \text{ kJ/kg}$$

From the air table (Table A-17),

$$T_1 = 295 \text{ K} \longrightarrow h_1 = 295.17 \text{ kJ/kg}$$

$$T_2 = 620 \text{ K} \longrightarrow h_2 = 628.07 \text{ kJ/kg}$$

Analysis There is only one inlet and one exit for either device, and thus $\dot{m}_{\text{in}} = \dot{m}_{\text{out}} = \dot{m}$. We take either the turbine or the compressor as the system, which is a control volume since mass crosses the boundary. The energy balance for either steady-flow system can be expressed in the rate form as

$$\underbrace{\dot{E}_{\text{in}} - \dot{E}_{\text{out}}}_{\text{Rate of net energy transfer by heat, work, and mass}} = \underbrace{\dot{\Delta E}_{\text{system}}}_{\text{Rate of change in internal, kinetic, potential, etc. energies}} \stackrel{\approx 0 \text{ (steady)}}{=} 0$$

$$\dot{E}_{\text{in}} = \dot{E}_{\text{out}}$$

For the turbine and the compressor it becomes

Compressor:

$$\dot{W}_{\text{comp, in}} + \dot{m}_{\text{air}} h_1 = \dot{m}_{\text{air}} h_2 \longrightarrow \dot{W}_{\text{comp, in}} = \dot{m}_{\text{air}} (h_2 - h_1)$$

Turbine:

$$\dot{m}_{\text{steam}} h_3 = \dot{W}_{\text{turb, out}} + \dot{m}_{\text{steam}} h_4 \longrightarrow \dot{W}_{\text{turb, out}} = \dot{m}_{\text{steam}} (h_3 - h_4)$$

Substituting,

$$\dot{W}_{\text{comp, in}} = (10 \text{ kg/s})(628.07 - 295.17) \text{ kJ/kg} = 3329 \text{ kW}$$

$$\dot{W}_{\text{turb, out}} = (25 \text{ kg/s})(3343.6 - 2392.5) \text{ kJ/kg} = 23,777 \text{ kW}$$

Therefore,

$$\dot{W}_{\text{net, out}} = \dot{W}_{\text{turb, out}} - \dot{W}_{\text{comp, in}} = 23,777 - 3329 = \mathbf{20,448 \text{ kW}}$$

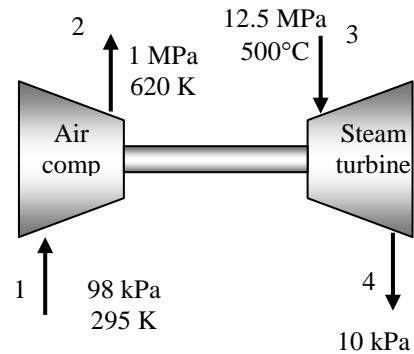

5-171 Helium is compressed by a compressor. The power required is to be determined.

Assumptions 1 This is a steady-flow process since there is no change with time. **2** Kinetic and potential energy changes are negligible. **3** Helium is an ideal gas with constant specific heats. **4** The compressor is adiabatic.

Properties The constant pressure specific heat of helium is $c_p = 5.1926 \text{ kJ/kg}\cdot\text{K}$. The gas constant is $R = 2.0769 \text{ kJ/kg}\cdot\text{K}$ (Table A-2a).

Analysis There is only one inlet and one exit, and thus $\dot{m}_1 = \dot{m}_2 = \dot{m}$. We take the compressor as the system, which is a control volume since mass crosses the boundary. The energy balance for this steady-flow system can be expressed in the rate form as

$$\underbrace{\dot{E}_{\text{in}} - \dot{E}_{\text{out}}}_{\substack{\text{Rate of net energy transfer} \\ \text{by heat, work, and mass}}} = \underbrace{\Delta \dot{E}_{\text{system}}}_{\substack{\text{Rate of change in internal, kinetic,} \\ \text{potential, etc. energies}}} \stackrel{\approx 0 \text{ (steady)}}{=} 0$$

$$\dot{E}_{\text{in}} = \dot{E}_{\text{out}}$$

$$\dot{W}_{\text{in}} + \dot{m}h_1 = \dot{m}h_2 \quad (\text{since } \Delta ke \cong \Delta pe \cong 0)$$

$$\dot{W}_{\text{in}} = \dot{m}(h_2 - h_1) = \dot{m}c_p(T_2 - T_1)$$

The specific volume of air at the inlet and the mass flow rate are

$$v_1 = \frac{RT_1}{P_1} = \frac{(2.0769 \text{ kPa} \cdot \text{m}^3/\text{kg} \cdot \text{K})(20 + 273 \text{ K})}{110 \text{ kPa}} = 5.532 \text{ m}^3/\text{kg}$$

$$\dot{m} = \frac{A_1 V_1}{v_1} = \frac{(0.1 \text{ m}^2)(9 \text{ m/s})}{5.532 \text{ m}^3/\text{kg}} = 0.1627 \text{ kg/s}$$

Then the power input is determined from the energy balance equation to be

$$\dot{W}_{\text{in}} = \dot{m}c_p(T_2 - T_1) = (0.1627 \text{ kg/s})(5.1926 \text{ kJ/kg} \cdot \text{K})(200 - 20)\text{K} = \mathbf{152 \text{ kW}}$$

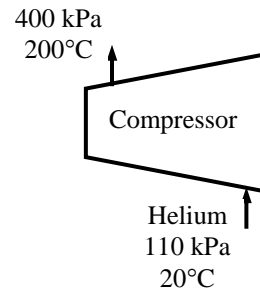

5-172 Saturated R-134a vapor is compressed to a specified state. The power input is given. The rate of heat transfer is to be determined.

Assumptions 1 This is a steady-flow process since there is no change with time. **2** Kinetic and potential energy changes are negligible.

Properties The enthalpy at the compressor exit is given to be $h_2 = 281.39$ kJ/kg. From the R-134a tables (Table A-11)

$$\left. \begin{array}{l} T_1 = 10^\circ\text{C} \\ x_1 = 1 \end{array} \right\} h_1 = 256.22 \text{ kJ/kg}$$

Analysis We take the compressor as the system, which is a control volume since mass crosses the boundary. Noting that one fluid stream enters and leaves the compressor, the energy balance for this steady-flow system can be expressed in the rate form as

$$\underbrace{\dot{E}_{\text{in}} - \dot{E}_{\text{out}}}_{\text{Rate of net energy transfer by heat, work, and mass}} = \underbrace{\Delta \dot{E}_{\text{system}}^{\neq 0} \text{ (steady)}}_{\text{Rate of change in internal, kinetic, potential, etc. energies}} = 0$$

$$\dot{E}_{\text{in}} = \dot{E}_{\text{out}}$$

$$\dot{W}_{\text{in}} - \dot{Q}_{\text{out}} + \dot{m} \left(h_1 + \frac{V_1^2}{2} \right) = \dot{m} \left(h_2 + \frac{V_2^2}{2} \right) \quad (\text{since } \Delta p e \cong 0)$$

$$\dot{Q}_{\text{out}} = \dot{W}_{\text{in}} + \dot{m} \left(h_1 - h_2 - \frac{V_2^2}{2} \right)$$

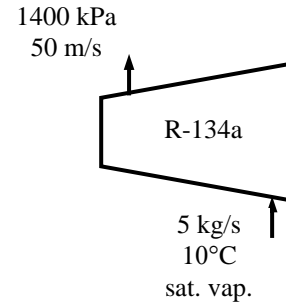

Substituting,

$$\begin{aligned} \dot{Q}_{\text{out}} &= \dot{W}_{\text{in}} + \dot{m} \left(h_1 - h_2 - \frac{V_2^2}{2} \right) \\ &= 132.4 \text{ kW} + (5 \text{ kg/s}) \left[256.22 - 281.39 \text{ kJ/kg} - \frac{(50 \text{ m/s})^2}{2} \left(\frac{1 \text{ kJ/kg}}{1000 \text{ m}^2/\text{s}^2} \right) \right] \\ &= \mathbf{0.3 \text{ kW}} \end{aligned}$$

which is very small and therefore the process is nearly adiabatic.

5-173 A submarine that has an air-ballast tank originally partially filled with air is considered. Air is pumped into the ballast tank until it is entirely filled with air. The final temperature and mass of the air in the ballast tank are to be determined.

Assumptions **1** Air is an ideal gas with constant specific heats. **2** The process is adiabatic. **3** There are no work interactions.

Properties The gas constant of air is $R = 0.287 \text{ kPa}\cdot\text{m}^3/\text{kg}\cdot\text{K}$ (Table A-1). The specific heat ratio of air at room temperature is $k = 1.4$ (Table A-2a). The specific volume of water is taken $0.001 \text{ m}^3/\text{kg}$.

Analysis The conservation of mass principle applied to the air gives

$$\frac{dm_a}{dt} = \dot{m}_{\text{in}}$$

and as applied to the water becomes

$$\frac{dm_w}{dt} = -\dot{m}_{\text{out}}$$

The first law for the ballast tank produces

$$0 = \frac{d(mu)_a}{dt} + \frac{d(mu)_w}{dt} + h_w \dot{m}_w - h_a \dot{m}_a$$

Combining this with the conservation of mass expressions, rearranging and canceling the common dt term produces

$$d(mu)_a + d(mu)_w = h_a dm_a + h_w dm_w$$

Integrating this result from the beginning to the end of the process gives

$$[(mu)_2 - (mu)_1]_a + [(mu)_2 - (mu)_1]_w = h_a (m_2 - m_1)_a + h_w (m_2 - m_1)_w$$

Substituting the ideal gas equation of state and the specific heat models for the enthalpies and internal energies expands this to

$$\frac{P\mathcal{V}_2}{RT_2} c_v T_2 - \frac{P\mathcal{V}_1}{RT_1} c_v T_1 - m_{w,1} c_w T_w = c_p T_{\text{in}} \left(\frac{P\mathcal{V}_2}{RT_2} - \frac{P\mathcal{V}_1}{RT_1} \right) - m_{w,1} c_w T_w$$

When the common terms are cancelled, this result becomes

$$T_2 = \frac{\mathcal{V}_2}{\frac{\mathcal{V}_1}{T_1} + \frac{1}{kT_{\text{in}}} (\mathcal{V}_2 - \mathcal{V}_1)} = \frac{700}{\frac{100}{288} + \frac{1}{(1.4)(293)} (700 - 100)} = \mathbf{386.8\text{K}}$$

The final mass from the ideal gas relation is

$$m_2 = \frac{P\mathcal{V}_2}{RT_2} = \frac{(1500 \text{ kPa})(700 \text{ m}^3)}{(0.287 \text{ kPa}\cdot\text{m}^3/\text{kg}\cdot\text{K})(386.8 \text{ K})} = \mathbf{9460\text{kg}}$$

5-174 A submarine that has an air-ballast tank originally partially filled with air is considered. Air is pumped into the ballast tank in an isothermal manner until it is entirely filled with air. The final mass of the air in the ballast tank and the total heat transfer are to be determined.

Assumptions 1 Air is an ideal gas with constant specific heats. 2 There are no work interactions.

Properties The gas constant of air is $R = 0.287 \text{ kPa}\cdot\text{m}^3/\text{kg}\cdot\text{K}$ (Table A-1). The specific heats of air at room temperature are $c_p = 1.005 \text{ kJ/kg}\cdot\text{K}$ and $c_v = 0.718 \text{ kJ/kg}\cdot\text{K}$ (Table A-2a). The specific volume of water is taken $0.001 \text{ m}^3/\text{kg}$.

Analysis The initial air mass is

$$m_1 = \frac{P_1 V_1}{RT_1} = \frac{(1500 \text{ kPa})(100 \text{ m}^3)}{(0.287 \text{ kPa}\cdot\text{m}^3/\text{kg}\cdot\text{K})(288.15 \text{ K})} = 1814 \text{ kg}$$

and the initial water mass is

$$m_w = \frac{V_1}{v_1} = \frac{600 \text{ m}^3}{0.001 \text{ m}^3/\text{kg}} = 600,000 \text{ kg}$$

and the final mass of air in the tank is

$$m_2 = \frac{P_2 V_2}{RT_2} = \frac{(1500 \text{ kPa})(700 \text{ m}^3)}{(0.287 \text{ kPa}\cdot\text{m}^3/\text{kg}\cdot\text{K})(288.15 \text{ K})} = \mathbf{12,697 \text{ kg}}$$

The first law when adapted to this system gives

$$\begin{aligned} Q_{\text{in}} + m_i h_i - m_e h_e &= m_2 u_2 - m_1 u_1 \\ Q_{\text{in}} &= m_2 u_2 - m_1 u_1 + m_e h_e - m_i h_i \\ Q_{\text{in}} &= m_2 c_v T - (m_{a,1} c_v T + m_w u_w) + m_w h_w - (m_2 - m_1) c_p T \end{aligned}$$

Noting that

$$u_w \cong h_w = 62.98 \text{ kJ/kg}$$

Substituting,

$$\begin{aligned} Q_{\text{in}} &= 12,697 \times 0.718 \times 288 - (1814 \times 0.718 \times 288 + 600,000 \times 62.98) \\ &\quad + 600,000 \times 62.98 - (12,697 - 1814) \times 1.005 \times 288 \\ &= \mathbf{0 \text{ kJ}} \end{aligned}$$

The process is adiabatic.

5-175 Water is heated from 16°C to 43°C by an electric resistance heater placed in the water pipe as it flows through a showerhead steadily at a rate of 10 L/min. The electric power input to the heater, and the money that will be saved during a 10-min shower by installing a heat exchanger with an effectiveness of 0.50 are to be determined.

Assumptions 1 This is a steady-flow process since there is no change with time at any point within the system and thus $\Delta m_{CV} = 0$ and $\Delta E_{CV} = 0$. **2** Water is an incompressible substance with constant specific heats. **3** The kinetic and potential energy changes are negligible, $\Delta ke \cong \Delta pe \cong 0$. **4** Heat losses from the pipe are negligible.

Properties The density and specific heat of water at room temperature are $\rho = 1 \text{ kg/L}$ and $c = 4.18 \text{ kJ/kg}\cdot^\circ\text{C}$ (Table A-3).

Analysis We take the pipe as the system. This is a *control volume* since mass crosses the system boundary during the process. We observe that there is only one inlet and one exit and thus $\dot{m}_1 = \dot{m}_2 = \dot{m}$. Then the energy balance for this steady-flow system can be expressed in the rate form as

$$\underbrace{\dot{E}_{\text{in}} - \dot{E}_{\text{out}}}_{\text{Rate of net energy transfer by heat, work, and mass}} = \underbrace{\Delta \dot{E}_{\text{system}}^{\text{no (steady)}}}_{\text{Rate of change in internal, kinetic, potential, etc. energies}} = 0 \rightarrow \dot{E}_{\text{in}} = \dot{E}_{\text{out}}$$

$$\dot{W}_{e,\text{in}} + \dot{m}h_1 = \dot{m}h_2 \quad (\text{since } \Delta ke \cong \Delta pe \cong 0)$$

$$\dot{W}_{e,\text{in}} = \dot{m}(h_2 - h_1) = \dot{m}[c(T_2 - T_1) + v(P_2 - P_1)^{\text{no}}] = \dot{m}c(T_2 - T_1)$$

where

$$\dot{m} = \rho \dot{V} = (1 \text{ kg/L})(10 \text{ L/min}) = 10 \text{ kg/min}$$

Substituting,

$$\dot{W}_{e,\text{in}} = (10/60 \text{ kg/s})(4.18 \text{ kJ/kg}\cdot^\circ\text{C})(43 - 16)^\circ\text{C} = \mathbf{18.8 \text{ kW}}$$

The energy recovered by the heat exchanger is

$$\begin{aligned} \dot{Q}_{\text{saved}} &= \varepsilon \dot{Q}_{\text{max}} = \varepsilon \dot{m}c(T_{\text{max}} - T_{\text{min}}) \\ &= 0.5(10/60 \text{ kg/s})(4.18 \text{ kJ/kg}\cdot^\circ\text{C})(39 - 16)^\circ\text{C} \\ &= 8.0 \text{ kJ/s} = 8.0 \text{ kW} \end{aligned}$$

Therefore, 8.0 kW less energy is needed in this case, and the required electric power in this case reduces to

$$\dot{W}_{\text{in,new}} = \dot{W}_{\text{in,old}} - \dot{Q}_{\text{saved}} = 18.8 - 8.0 = \mathbf{10.8 \text{ kW}}$$

The money saved during a 10-min shower as a result of installing this heat exchanger is

$$(8.0 \text{ kW})(10/60 \text{ h})(11.5 \text{ cents/kWh}) = \mathbf{15.3 \text{ cents}}$$

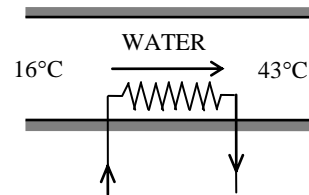



5-176 Problem 5-175 is reconsidered. The effect of the heat exchanger effectiveness on the money saved as the effectiveness ranges from 20 percent to 90 percent is to be investigated, and the money saved is to be plotted against the effectiveness.

Analysis The problem is solved using EES, and the results are tabulated and plotted below.

"Knowns:"

density = 1 [kg/L]
 $\dot{V}_{\text{water}} = 10$ [L/min]
 $C = 4.18$ [kJ/kg-C]
 $T_1 = 16$ [C]
 $T_2 = 43$ [C]
 $T_{\text{max}} = 39$ [C]
 $T_{\text{min}} = T_1$
 epsilon = 0.5 "heat exchanger effectiveness"
 EleRate = 11.5 [cents/kWh]

"For entrance, one exit, steady flow $\dot{m}_{\text{in}} = \dot{m}_{\text{out}} = \dot{m}_{\text{water}}$:"

$\dot{m}_{\text{water}} = \text{density} * \dot{V}_{\text{water}} / \text{convert}(\text{min}, \text{s})$

"Energy balance for the pipe:"

$\dot{W}_{\text{dot_ele_in}} + \dot{m}_{\text{water}} * h_1 = \dot{m}_{\text{water}} * h_2$ "Neglect ke and pe"

"For incompressible fluid in a constant pressure process, the enthalpy is:"

$h_1 = C * T_1$

$h_2 = C * T_2$

"The energy recovered by the heat exchanger is"

$\dot{Q}_{\text{dot_saved}} = \text{epsilon} * \dot{Q}_{\text{dot_max}}$

$\dot{Q}_{\text{dot_max}} = \dot{m}_{\text{water}} * C * (T_{\text{max}} - T_{\text{min}})$

"Therefore, 8.0 kW less energy is needed in this case, and the required electric power in this case reduces to"

$\dot{W}_{\text{dot_ele_new}} = \dot{W}_{\text{dot_ele_in}} - \dot{Q}_{\text{dot_saved}}$

"The money saved during a 10-min shower as a result of installing this heat exchanger is"

$\text{Costs_saved} = \dot{Q}_{\text{dot_saved}} * \text{time} * \text{convert}(\text{min}, \text{h}) * \text{EleRate}$

time=10 [min]

Costs _{saved} [cents]	ϵ
6.142	0.2
9.213	0.3
12.28	0.4
15.36	0.5
18.43	0.6
21.5	0.7
24.57	0.8
27.64	0.9

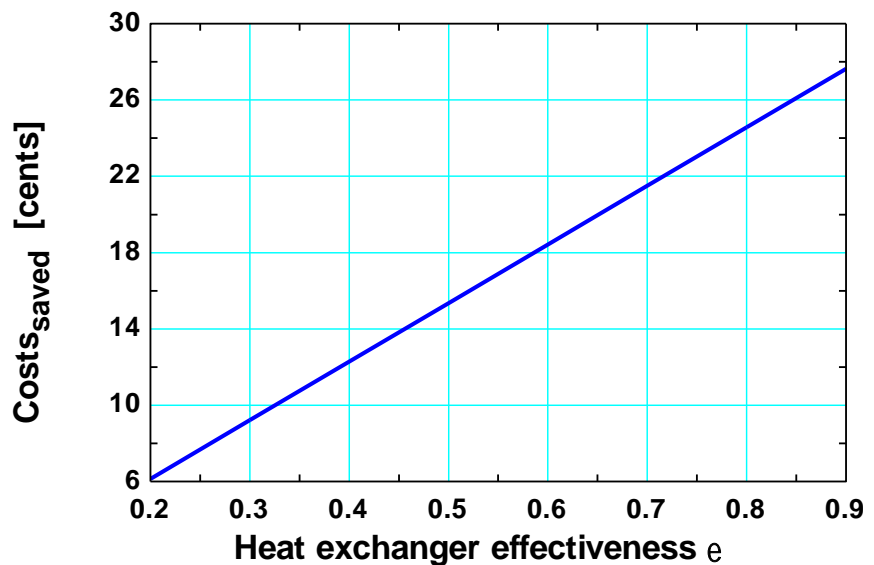

5-177 The air in a tank is released until the pressure in the tank reduces to a specified value. The mass withdrawn from the tank is to be determined for three methods of analysis.

Assumptions 1 This is an unsteady process since the conditions within the device are changing during the process, but it can be analyzed as a uniform-flow process. **2** Air is an ideal gas with constant specific heats. **3** Kinetic and potential energies are negligible. **4** There are no work or heat interactions involved.

Properties The gas constant of air is $0.287 \text{ kPa}\cdot\text{m}^3/\text{kg}\cdot\text{K}$ (Table A-1). The specific heats of air at room temperature are $c_p = 1.005 \text{ kJ/kg}\cdot\text{K}$ and $c_v = 0.718 \text{ kJ/kg}\cdot\text{K}$. Also $k = 1.4$ (Table A-2a).

Analysis (a) We take the tank as the system, which is a control volume since mass crosses the boundary. Noting that the microscopic energies of flowing and nonflowing fluids are represented by enthalpy h and internal energy u , respectively, the mass and energy balances for this uniform-flow system can be expressed as

Mass balance:

$$m_{\text{in}} - m_{\text{out}} = \Delta m_{\text{system}}$$

$$-m_e = m_2 - m_1$$

$$m_e = m_1 - m_2$$

Energy balance:

$$\underbrace{E_{\text{in}} - E_{\text{out}}}_{\text{Net energy transfer by heat, work, and mass}} = \underbrace{\Delta E_{\text{system}}}_{\text{Change in internal, kinetic, potential, etc. energies}}$$

$$-m_e h_e = m_2 u_2 - m_1 u_1$$

$$0 = m_2 u_2 - m_1 u_1 + m_e h_e$$

$$0 = m_2 c_v T_2 - m_1 c_v T_1 + m_e c_p T_e$$

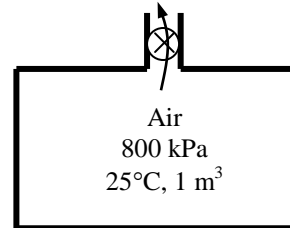

Combining the two balances:

$$0 = m_2 c_v T_2 - m_1 c_v T_1 + (m_1 - m_2) c_p T_e$$

The initial and final masses are given by

$$m_1 = \frac{P_1 \mathcal{V}}{RT_1} = \frac{(800 \text{ kPa})(1 \text{ m}^3)}{(0.287 \text{ kPa}\cdot\text{m}^3/\text{kg}\cdot\text{K})(25 + 273 \text{ K})} = 9.354 \text{ kg}$$

$$m_2 = \frac{P_2 \mathcal{V}}{RT_2} = \frac{(150 \text{ kPa})(1 \text{ m}^3)}{(0.287 \text{ kPa}\cdot\text{m}^3/\text{kg}\cdot\text{K})T_2} = \frac{522.6}{T_2}$$

The temperature of air leaving the tank changes from the initial temperature in the tank to the final temperature during the discharging process. We assume that the temperature of the air leaving the tank is the average of initial and final temperatures in the tank. Substituting into the energy balance equation gives

$$0 = m_2 c_v T_2 - m_1 c_v T_1 + (m_1 - m_2) c_p T_e$$

$$0 = \frac{522.6}{T_2} (0.718) T_2 - (9.354)(0.718)(298) + \left(9.354 - \frac{522.6}{T_2}\right) (1.005) \left(\frac{298 + T_2}{2}\right)$$

whose solution is

$$T_2 = 191.0 \text{ K}$$

Substituting, the final mass is

$$m_2 = \frac{522.6}{191} = 2.736 \text{ kg}$$

and the mass withdrawn is

$$m_e = m_1 - m_2 = 9.354 - 2.736 = \mathbf{6.618 \text{ kg}}$$

(b) Considering the process in two parts, first from 800 kPa to 400 kPa and from 400 kPa to 150 kPa, the solution will be as follows:

From 800 kPa to 400 kPa:

$$m_2 = \frac{P_2 \mathcal{V}}{RT_2} = \frac{(400 \text{ kPa})(1 \text{ m}^3)}{(0.287 \text{ kPa}\cdot\text{m}^3/\text{kg}\cdot\text{K})T_2} = \frac{1394}{T_2}$$

$$0 = \frac{1394}{T_2} (0.718)T_2 - (9.354)(0.718)(298) + \left(9.354 - \frac{1394}{T_2}\right)(1.005)\left(\frac{298 + T_2}{2}\right)$$

$$T_2 = 245.1 \text{ K}$$

$$m_2 = \frac{1394}{245.1} = 5.687 \text{ kg}$$

$$m_{e,1} = m_1 - m_2 = 9.354 - 5.687 = 3.667 \text{ kg}$$

From 400 kPa to 150 kPa:

$$0 = \frac{522.6}{T_2} (0.718)T_2 - (5.687)(0.718)(245.1) + \left(5.687 - \frac{522.6}{T_2}\right)(1.005)\left(\frac{245.1 + T_2}{2}\right)$$

$$T_2 = 186.5 \text{ K}$$

$$m_2 = \frac{522.6}{186.5} = 2.803 \text{ kg}$$

$$m_{e,2} = m_1 - m_2 = 5.687 - 2.803 = 2.884 \text{ kg}$$

The total mass withdrawn is

$$m_e = m_{e,1} + m_{e,2} = 3.667 + 2.884 = \mathbf{6.551 \text{ kg}}$$

(c) The mass balance may be written as

$$\frac{dm}{dt} = -\dot{m}_e$$

When this is combined with the ideal gas equation of state, it becomes

$$\frac{V}{R} \frac{d(P/T)}{dt} = -\dot{m}_e$$

since the tank volume remains constant during the process. An energy balance on the tank gives

$$\begin{aligned} \frac{d(mu)}{dt} &= -h_e \dot{m}_e \\ c_v \frac{d(mT)}{dt} &= c_p T \frac{dm}{dt} \\ c_v \frac{V}{R} \frac{dP}{dt} &= c_p T \frac{V}{R} \frac{d(P/T)}{dt} \\ c_v \frac{dP}{dt} &= c_p \left(\frac{dP}{dt} - \frac{P}{T} \frac{dT}{dt} \right) \\ (c_p - c_v) \frac{dP}{P} &= c_p \frac{dT}{T} \end{aligned}$$

When this result is integrated, it gives

$$T_2 = T_1 \left(\frac{P_2}{P_1} \right)^{(k-1)/k} = (298 \text{ K}) \left(\frac{150 \text{ kPa}}{800 \text{ kPa}} \right)^{0.4/1.4} = 184.7 \text{ K}$$

The final mass is

$$m_2 = \frac{P_2 V}{RT_2} = \frac{(150 \text{ kPa})(1 \text{ m}^3)}{(0.287 \text{ kPa} \cdot \text{m}^3/\text{kg} \cdot \text{K})(184.7 \text{ K})} = 2.830 \text{ kg}$$

and the mass withdrawn is

$$m_e = m_1 - m_2 = 9.354 - 2.830 = \mathbf{6.524 \text{ kg}}$$

Discussion The result in first method is in error by 1.4% while that in the second method is in error by 0.4%.

5-178 A tank initially contains saturated mixture of R-134a. A valve is opened and R-134a vapor only is allowed to escape slowly such that temperature remains constant. The heat transfer necessary with the surroundings to maintain the temperature and pressure of the R-134a constant is to be determined.

Assumptions 1 This is an unsteady process since the conditions within the device are changing during the process, but it can be analyzed as a uniform-flow process since the state of fluid at the exit remains constant. **2** Kinetic and potential energies are negligible. **3** There are no work interactions involved.

Analysis We take the tank as the system, which is a control volume since mass crosses the boundary. Noting that the microscopic energies of flowing and nonflowing fluids are represented by enthalpy h and internal energy u , respectively, the mass and energy balances for this uniform-flow system can be expressed as

Mass balance:

$$\begin{aligned} m_{\text{in}} - m_{\text{out}} &= \Delta m_{\text{system}} \\ -m_e &= m_2 - m_1 \\ m_e &= m_1 - m_2 \end{aligned}$$

Energy balance:

$$\underbrace{E_{\text{in}} - E_{\text{out}}}_{\text{Net energy transfer by heat, work, and mass}} = \underbrace{\Delta E_{\text{system}}}_{\text{Change in internal, kinetic, potential, etc. energies}}$$

$$\begin{aligned} Q_{\text{in}} - m_e h_e &= m_2 u_2 - m_1 u_1 \\ Q_{\text{in}} &= m_2 u_2 - m_1 u_1 + m_e h_e \end{aligned}$$

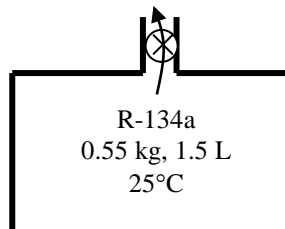

Combining the two balances:

$$Q_{\text{in}} = m_2 u_2 - m_1 u_1 + (m_1 - m_2) h_e$$

The specific volume at the initial state is

$$\nu_1 = \frac{\mathcal{V}}{m_1} = \frac{0.0015 \text{ m}^3}{0.55 \text{ kg}} = 0.002727 \text{ m}^3/\text{kg}$$

The initial state properties of R-134a in the tank are

$$\left. \begin{aligned} T_1 &= 26^\circ\text{C} \\ \nu_1 &= 0.002727 \text{ m}^3/\text{kg} \end{aligned} \right\} \begin{aligned} x_1 &= \frac{\nu_1 - \nu_f}{\nu_{fg}} = \frac{0.002727 - 0.0008312}{0.030008 - 0.0008312} = 0.06499 \\ u_1 &= u_f + x_1 u_{fg} = 87.26 + (0.06499)(156.89) = 97.45 \text{ kJ/kg} \end{aligned} \quad (\text{Table A-11})$$

The enthalpy of saturated vapor refrigerant leaving the bottle is

$$h_e = h_{g@26^\circ\text{C}} = 264.73 \text{ kJ/kg}$$

The specific volume at the final state is

$$\nu_2 = \frac{\mathcal{V}}{m_2} = \frac{0.0015 \text{ m}^3}{0.15 \text{ kg}} = 0.01 \text{ m}^3/\text{kg}$$

The internal energy at the final state is

$$\left. \begin{aligned} T_2 &= 26^\circ\text{C} \\ \nu_2 &= 0.01 \text{ m}^3/\text{kg} \end{aligned} \right\} \begin{aligned} x_2 &= \frac{\nu_2 - \nu_f}{\nu_{fg}} = \frac{0.01 - 0.0008312}{0.030008 - 0.0008312} = 0.3143 \\ u_2 &= u_f + x_2 u_{fg} = 87.26 + (0.3143)(156.89) = 136.56 \text{ kJ/kg} \end{aligned} \quad (\text{Table A-11})$$

Substituting into the energy balance equation,

$$\begin{aligned} Q_{\text{in}} &= m_2 u_2 - m_1 u_1 + (m_1 - m_2) h_e \\ &= (0.15 \text{ kg})(136.56 \text{ kJ/kg}) - (0.55 \text{ kg})(97.45 \text{ kJ/kg}) + (0.55 - 0.15 \text{ kg})(264.73 \text{ kJ/kg}) \\ &= \mathbf{72.8 \text{ kJ}} \end{aligned}$$

5-179  Steam expands in a turbine steadily. The mass flow rate of the steam, the exit velocity, and the power output are to be determined.

Assumptions 1 This is a steady-flow process since there is no change with time.

2 Potential energy changes are negligible.

Properties From the steam tables (Tables A-4 through 6)

$$\left. \begin{array}{l} P_1 = 7 \text{ MPa} \\ T_1 = 600^\circ\text{C} \end{array} \right\} \begin{array}{l} v_1 = 0.05567 \text{ m}^3/\text{kg} \\ h_1 = 3650.6 \text{ kJ/kg} \end{array}$$

and

$$\left. \begin{array}{l} P_2 = 25 \text{ kPa} \\ x_2 = 0.95 \end{array} \right\} \begin{array}{l} v_2 = v_f + x_2 v_{fg} = 0.00102 + (0.95)(6.2034 - 0.00102) = 5.8933 \text{ m}^3/\text{kg} \\ h_2 = h_f + x_2 h_{fg} = 271.96 + (0.95)(2345.5) = 2500.2 \text{ kJ/kg} \end{array}$$

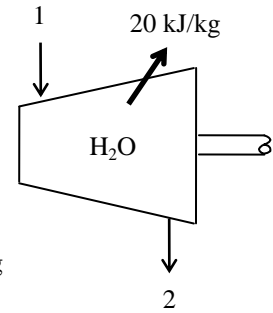

Analysis (a) The mass flow rate of the steam is

$$\dot{m} = \frac{1}{v_1} V_1 A_1 = \frac{1}{0.05567 \text{ m}^3/\text{kg}} (60 \text{ m/s})(0.015 \text{ m}^2) = \mathbf{16.17 \text{ kg/s}}$$

(b) There is only one inlet and one exit, and thus $\dot{m}_1 = \dot{m}_2 = \dot{m}$. Then the exit velocity is determined from

$$\dot{m} = \frac{1}{v_2} V_2 A_2 \longrightarrow V_2 = \frac{\dot{m} v_2}{A_2} = \frac{(16.17 \text{ kg/s})(5.8933 \text{ m}^3/\text{kg})}{0.14 \text{ m}^2} = \mathbf{680.6 \text{ m/s}}$$

(c) We take the turbine as the system, which is a control volume since mass crosses the boundary. The energy balance for this steady-flow system can be expressed in the rate form as

$$\underbrace{\dot{E}_{\text{in}} - \dot{E}_{\text{out}}}_{\substack{\text{Rate of net energy transfer} \\ \text{by heat, work, and mass}}} = \underbrace{\Delta \dot{E}_{\text{system}}}_{\substack{\text{Rate of change in internal, kinetic,} \\ \text{potential, etc. energies}}} \stackrel{\text{no (steady)}}{=} 0$$

$$\dot{E}_{\text{in}} = \dot{E}_{\text{out}}$$

$$\dot{m}(h_1 + V_1^2/2) = \dot{W}_{\text{out}} + \dot{Q}_{\text{out}} + \dot{m}(h_2 + V_2^2/2) \quad (\text{since } \Delta p e \cong 0)$$

$$\dot{W}_{\text{out}} = -\dot{Q}_{\text{out}} - \dot{m} \left(h_2 - h_1 + \frac{V_2^2 - V_1^2}{2} \right)$$

Then the power output of the turbine is determined by substituting to be

$$\begin{aligned} \dot{W}_{\text{out}} &= -(16.17 \times 20) \text{ kJ/s} - (16.17 \text{ kg/s}) \left(2500.2 - 3650.6 + \frac{(680.6 \text{ m/s})^2 - (60 \text{ m/s})^2}{2} \left(\frac{1 \text{ kJ/kg}}{1000 \text{ m}^2/\text{s}^2} \right) \right) \\ &= \mathbf{14,560 \text{ kW}} \end{aligned}$$



5-180 Problem 5-179 is reconsidered. The effects of turbine exit area and turbine exit pressure on the exit velocity and power output of the turbine as the exit pressure varies from 10 kPa to 50 kPa (with the same quality), and the exit area to varies from 1000 cm² to 3000 cm² is to be investigated. The exit velocity and the power output are to be plotted against the exit pressure for the exit areas of 1000, 2000, and 3000 cm².

Analysis The problem is solved using EES, and the results are tabulated and plotted below.

```

Fluid$='Steam_IAPWS'
A[1]=150 [cm^2]
T[1]=600 [C]
P[1]=7000 [kPa]
Vel[1]= 60 [m/s]
A[2]=1400 [cm^2]
P[2]=25 [kPa]
q_out = 20 [kJ/kg]
m_dot = A[1]*Vel[1]/v[1]*convert(cm^2,m^2)
v[1]=volume(Fluid$, T=T[1], P=P[1]) "specific volume of steam at state 1"
Vel[2]=m_dot*v[2]/(A[2]*convert(cm^2,m^2))
v[2]=volume(Fluid$, x=0.95, P=P[2]) "specific volume of steam at state 2"
T[2]=temperature(Fluid$, P=P[2], v=v[2]) "[C]" "not required, but good to know"

"[conservation of Energy for steady-flow:"
"Ein_dot - Eout_dot = DeltaE_dot" "For steady-flow, DeltaE_dot = 0"
DELTAE_dot=0
"For the turbine as the control volume, neglecting the PE of each flow steam:"
E_dot_in=E_dot_out
h[1]=enthalpy(Fluid$,T=T[1], P=P[1])
E_dot_in=m_dot*(h[1]+ Vel[1]^2/2*Convert(m^2/s^2, kJ/kg))
h[2]=enthalpy(Fluid$,x=0.95, P=P[2])
E_dot_out=m_dot*(h[2]+ Vel[2]^2/2*Convert(m^2/s^2, kJ/kg))+ m_dot *q_out+ W_dot_out
Power=W_dot_out
Q_dot_out=m_dot*q_out

```

P ₂ [kPa]	Power [kW]	Vel ₂ [m/s]
10	-22158	2253
14.44	-1895	1595
18.89	6071	1239
23.33	9998	1017
27.78	12212	863.2
32.22	13573	751.1
36.67	14464	665.4
41.11	15075	597.8
45.56	15507	543
50	15821	497.7

Table values are for A₂=1000 [cm²]

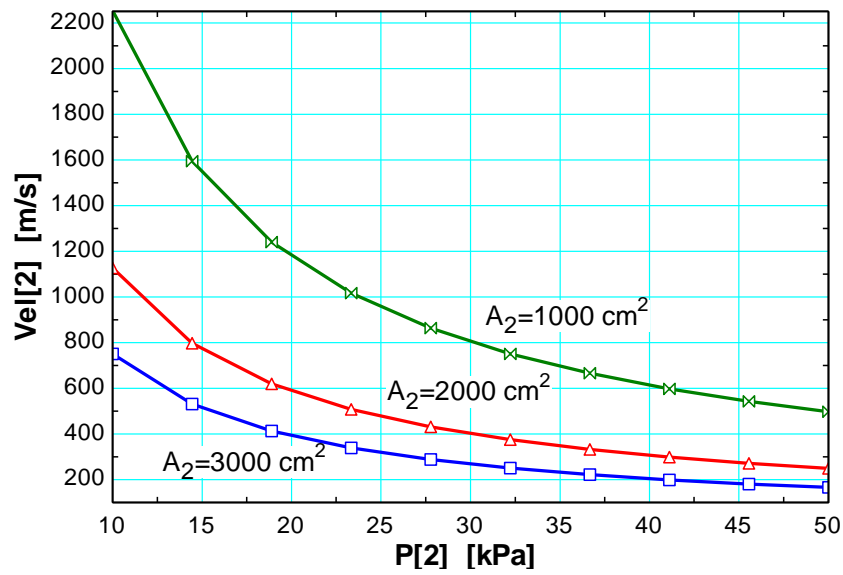
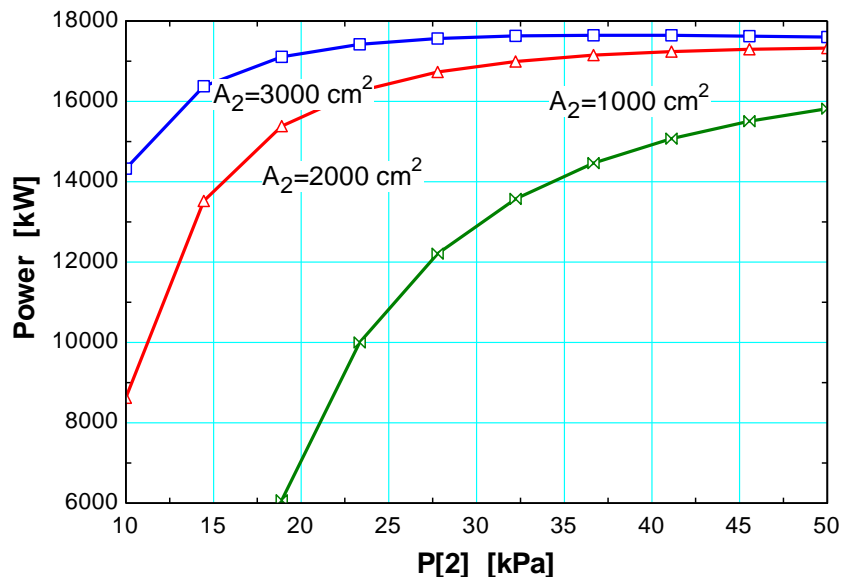

5-181 Air is preheated by the exhaust gases of a gas turbine in a regenerator. For a specified heat transfer rate, the exit temperature of air and the mass flow rate of exhaust gases are to be determined.

Assumptions 1 This is a steady-flow process since there is no change with time. 2 Kinetic and potential energy changes are negligible. 3 There are no work interactions. 4 Heat loss from the regenerator to the surroundings is negligible and thus heat transfer from the hot fluid is equal to the heat transfer to the cold fluid. 5 Exhaust gases can be treated as air. 6 Air is an ideal gas with variable specific heats.

Properties The gas constant of air is $0.287 \text{ kPa}\cdot\text{m}^3/\text{kg}\cdot\text{K}$ (Table A-1). The enthalpies of air are (Table A-17)

$$T_1 = 550 \text{ K} \rightarrow h_1 = 555.74 \text{ kJ/kg}$$

$$T_3 = 800 \text{ K} \rightarrow h_3 = 821.95 \text{ kJ/kg}$$

$$T_4 = 600 \text{ K} \rightarrow h_4 = 607.02 \text{ kJ/kg}$$

Analysis (a) We take the *air side* of the heat exchanger as the system, which is a control volume since mass crosses the boundary. There is only one inlet and one exit, and thus $\dot{m}_1 = \dot{m}_2 = \dot{m}$. The energy balance for this steady-flow system can be expressed in the rate form as

$$\underbrace{\dot{E}_{\text{in}} - \dot{E}_{\text{out}}}_{\text{Rate of net energy transfer by heat, work, and mass}} = \underbrace{\Delta \dot{E}_{\text{system}}}_{\text{Rate of change in internal, kinetic, potential, etc. energies}} \stackrel{\text{no (steady)}}{=} 0$$

$$\dot{E}_{\text{in}} = \dot{E}_{\text{out}}$$

$$\dot{Q}_{\text{in}} + \dot{m}_{\text{air}} h_1 = \dot{m}_{\text{air}} h_2 \quad (\text{since } \dot{W} = \Delta \text{ke} \cong \Delta \text{pe} \cong 0)$$

$$\dot{Q}_{\text{in}} = \dot{m}_{\text{air}} (h_2 - h_1)$$

Substituting,

$$3200 \text{ kJ/s} = (800/60 \text{ kg/s})(h_2 - 554.71 \text{ kJ/kg}) \rightarrow h_2 = 794.71 \text{ kJ/kg}$$

Then from Table A-17 we read

$$T_2 = \mathbf{775.1 \text{ K}}$$

(b) Treating the exhaust gases as an ideal gas, the mass flow rate of the exhaust gases is determined from the steady-flow energy relation applied only to the exhaust gases,

$$\dot{E}_{\text{in}} = \dot{E}_{\text{out}}$$

$$\dot{m}_{\text{exhaust}} h_3 = \dot{Q}_{\text{out}} + \dot{m}_{\text{exhaust}} h_4 \quad (\text{since } \dot{W} = \Delta \text{ke} \cong \Delta \text{pe} \cong 0)$$

$$\dot{Q}_{\text{out}} = \dot{m}_{\text{exhaust}} (h_3 - h_4)$$

$$3200 \text{ kJ/s} = \dot{m}_{\text{exhaust}} (821.95 - 607.02) \text{ kJ/kg}$$

It yields

$$\dot{m}_{\text{exhaust}} = \mathbf{14.9 \text{ kg/s}}$$

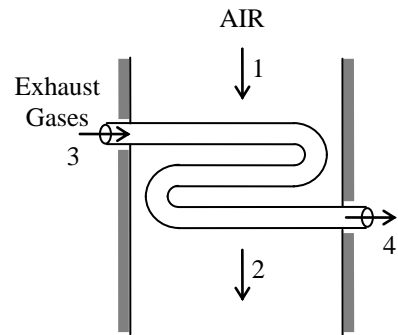

5-182 Water is to be heated steadily from 20°C to 48°C by an electrical resistor inside an insulated pipe. The power rating of the resistance heater and the average velocity of the water are to be determined.

Assumptions 1 This is a steady-flow process since there is no change with time at any point within the system and thus $\Delta m_{CV} = 0$ and $\Delta E_{CV} = 0$. **2** Water is an incompressible substance with constant specific heats. **3** The kinetic and potential energy changes are negligible, $\Delta ke \cong \Delta pe \cong 0$. **4** The pipe is insulated and thus the heat losses are negligible.

Properties The density and specific heat of water at room temperature are $\rho = 1000 \text{ kg/m}^3$ and $c = 4.18 \text{ kJ/kg}\cdot^\circ\text{C}$ (Table A-3).

Analysis (a) We take the pipe as the system. This is a *control volume* since mass crosses the system boundary during the process. Also, there is only one inlet and one exit and thus $\dot{m}_1 = \dot{m}_2 = \dot{m}$. The energy balance for this steady-flow system can be expressed in the rate form as

$$\underbrace{\dot{E}_{in} - \dot{E}_{out}}_{\text{Rate of net energy transfer by heat, work, and mass}} = \underbrace{\Delta \dot{E}_{system}^{\phi 0}}_{\text{Rate of change in internal, kinetic, potential, etc. energies (steady)}} = 0$$

$$\dot{E}_{in} = \dot{E}_{out}$$

$$\dot{W}_{e,in} + \dot{m}h_1 = \dot{m}h_2 \quad (\text{since } \dot{Q}_{out} \cong \Delta ke \cong \Delta pe \cong 0)$$

$$\dot{W}_{e,in} = \dot{m}(h_2 - h_1) = \dot{m}[c(T_2 - T_1) + v\Delta P^{\phi 0}] = \dot{m}c(T_2 - T_1)$$

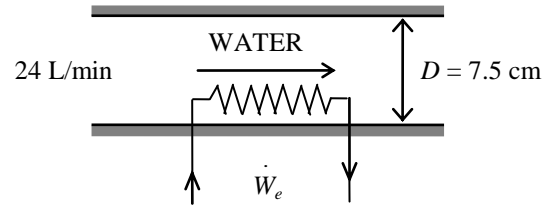

The mass flow rate of water through the pipe is

$$m = \rho \dot{V}_1 = (1000 \text{ kg/m}^3)(0.024 \text{ m}^3/\text{min}) = 24 \text{ kg/min}$$

Therefore,

$$\dot{W}_{e,in} = \dot{m}c(T_2 - T_1) = (24/60 \text{ kg/s})(4.18 \text{ kJ/kg}\cdot^\circ\text{C})(48 - 20)^\circ\text{C} = \mathbf{46.8 \text{ kW}}$$

(b) The average velocity of water through the pipe is determined from

$$V = \frac{\dot{V}}{A} = \frac{\dot{V}}{\pi r^2} = \frac{0.024 \text{ m}^3/\text{min}}{\pi(0.0375 \text{ m})^2} = \mathbf{5.43 \text{ m/min}}$$

5-183  An insulated cylinder equipped with an external spring initially contains air. The tank is connected to a supply line, and air is allowed to enter the cylinder until its volume doubles. The mass of the air that entered and the final temperature in the cylinder are to be determined.

Assumptions 1 This is an unsteady process since the conditions within the device are changing during the process, but it can be analyzed as a uniform-flow process since the state of fluid at the inlet remains constant. **2** The expansion process is quasi-equilibrium. **3** Kinetic and potential energies are negligible. **4** The spring is a linear spring. **5** The device is insulated and thus heat transfer is negligible. **6** Air is an ideal gas with constant specific heats.

Properties The gas constant of air is $R = 0.287 \text{ kJ/kg}\cdot\text{K}$ (Table A-1). The specific heats of air at room temperature are $c_v = 0.718$ and $c_p = 1.005 \text{ kJ/kg}\cdot\text{K}$ (Table A-2a). Also, $u = c_v T$ and $h = c_p T$.

Analysis We take the cylinder as the system, which is a control volume since mass crosses the boundary. Noting that the microscopic energies of flowing and nonflowing fluids are represented by enthalpy h and internal energy u , respectively, the mass and energy balances for this uniform-flow system can be expressed as

Mass balance:

$$m_{\text{in}} - m_{\text{out}} = \Delta m_{\text{system}} \rightarrow m_i = m_2 - m_1$$

Energy balance:

$$\underbrace{E_{\text{in}} - E_{\text{out}}}_{\text{Net energy transfer by heat, work, and mass}} = \underbrace{\Delta E_{\text{system}}}_{\text{Change in internal, kinetic, potential, etc. energies}}$$

$$m_i h_i = W_{b,\text{out}} + m_2 u_2 - m_1 u_1 \quad (\text{since } Q \cong \text{ke} \cong \text{pe} \cong 0)$$

Combining the two relations, $(m_2 - m_1)h_i = W_{b,\text{out}} + m_2 u_2 - m_1 u_1$

or, $(m_2 - m_1)c_p T_i = W_{b,\text{out}} + m_2 c_v T_2 - m_1 c_v T_1$

The initial and the final masses in the tank are

$$m_1 = \frac{P_1 \mathcal{V}_1}{RT_1} = \frac{(150 \text{ kPa})(0.11 \text{ m}^3)}{(0.287 \text{ kPa}\cdot\text{m}^3/\text{kg}\cdot\text{K})(295 \text{ K})} = 0.1949 \text{ kg}$$

$$m_2 = \frac{P_2 \mathcal{V}_2}{RT_2} = \frac{(600 \text{ kPa})(0.22 \text{ m}^3)}{(0.287 \text{ kPa}\cdot\text{m}^3/\text{kg}\cdot\text{K})T_2} = \frac{459.9}{T_2}$$

Then from the mass balance becomes $m_i = m_2 - m_1 = \frac{459.9}{T_2} - 0.1949$

The spring is a linear spring, and thus the boundary work for this process can be determined from

$$W_b = \text{Area} = \frac{P_1 + P_2}{2} (\mathcal{V}_2 - \mathcal{V}_1) = \frac{(150 + 600) \text{ kPa}}{2} (0.22 - 0.11) \text{ m}^3 = 41.25 \text{ kJ}$$

Substituting into the energy balance, the final temperature of air T_2 is determined to be

$$-41.25 = -\left(\frac{459.9}{T_2} - 0.1949\right)(1.005)(295) + \left(\frac{459.9}{T_2}\right)(0.718)(T_2) - (0.1949)(0.718)(295)$$

It yields $T_2 = \mathbf{351 \text{ K}}$

Thus, $m_2 = \frac{459.9}{T_2} = \frac{459.9}{351.4} = 1.309 \text{ kg}$

and $m_i = m_2 - m_1 = 1.309 - 0.1949 = \mathbf{1.11 \text{ kg}}$

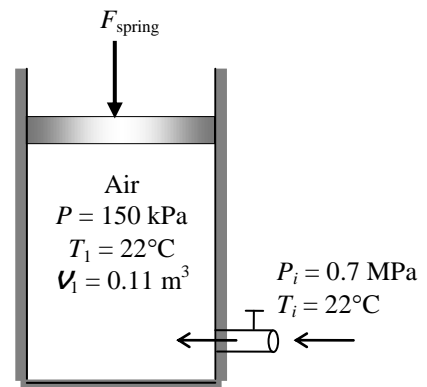

5-184 R-134a is allowed to leave a piston-cylinder device with a pair of stops. The work done and the heat transfer are to be determined.

Assumptions 1 This is an unsteady process since the conditions within the device are changing during the process, but it can be analyzed as a uniform-flow process since the state of fluid leaving the device is assumed to be constant. **2** Kinetic and potential energies are negligible.

Properties The properties of R-134a at various states are (Tables A-11 through A-13)

$$\left. \begin{array}{l} P_1 = 800 \text{ kPa} \\ T_1 = 80^\circ\text{C} \end{array} \right\} \begin{array}{l} \nu_1 = 0.032659 \text{ m}^3/\text{kg} \\ u_1 = 290.86 \text{ kJ/kg} \\ h_1 = 316.99 \text{ kJ/kg} \end{array}$$

$$\left. \begin{array}{l} P_2 = 500 \text{ kPa} \\ T_2 = 20^\circ\text{C} \end{array} \right\} \begin{array}{l} \nu_2 = 0.042115 \text{ m}^3/\text{kg} \\ u_2 = 242.42 \text{ kJ/kg} \\ h_2 = 263.48 \text{ kJ/kg} \end{array}$$

Analysis (a) We take the tank as the system, which is a control volume since mass crosses the boundary. Noting that the microscopic energies of flowing and nonflowing fluids are represented by enthalpy h and internal energy u , respectively, the mass and energy balances for this uniform-flow system can be expressed as

Mass balance:

$$m_{\text{in}} - m_{\text{out}} = \Delta m_{\text{system}} \rightarrow m_e = m_1 - m_2$$

Energy balance:

$$\underbrace{E_{\text{in}} - E_{\text{out}}}_{\substack{\text{Net energy transfer} \\ \text{by heat, work, and mass}}} = \underbrace{\Delta E_{\text{system}}}_{\substack{\text{Change in internal, kinetic,} \\ \text{potential, etc. energies}}}$$

$$W_{\text{b,in}} - Q_{\text{out}} - m_e h_e = m_2 u_2 - m_1 u_1 \quad (\text{since } k_e \cong p_e \cong 0)$$

The volumes at the initial and final states and the mass that has left the cylinder are

$$\mathcal{V}_1 = m_1 \nu_1 = (2 \text{ kg})(0.032659 \text{ m}^3/\text{kg}) = 0.06532 \text{ m}^3$$

$$\mathcal{V}_2 = m_2 \nu_2 = (1/2)m_1 \nu_2 = (1/2)(2 \text{ kg})(0.042115 \text{ m}^3/\text{kg}) = 0.04212 \text{ m}^3$$

$$m_e = m_1 - m_2 = 2 - 1 = 1 \text{ kg}$$

The enthalpy of the refrigerant withdrawn from the cylinder is assumed to be the average of initial and final enthalpies of the refrigerant in the cylinder

$$h_e = (1/2)(h_1 + h_2) = (1/2)(316.99 + 263.48) = 290.23 \text{ kJ/kg}$$

Noting that the pressure remains constant after the piston starts moving, the boundary work is determined from

$$W_{\text{b,in}} = P_2(\mathcal{V}_1 - \mathcal{V}_2) = (500 \text{ kPa})(0.06532 - 0.04212) \text{ m}^3 = \mathbf{11.6 \text{ kJ}}$$

(b) Substituting,

$$11.6 \text{ kJ} - Q_{\text{out}} - (1 \text{ kg})(290.23 \text{ kJ/kg}) = (1 \text{ kg})(242.42 \text{ kJ/kg}) - (2 \text{ kg})(290.86 \text{ kJ/kg})$$

$$Q_{\text{out}} = \mathbf{60.7 \text{ kJ}}$$

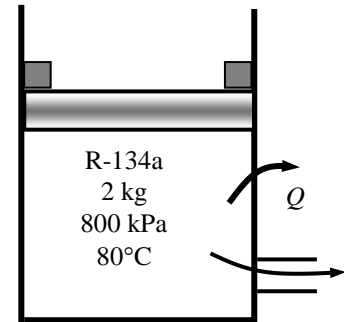

5-185 Air is allowed to leave a piston-cylinder device with a pair of stops. Heat is lost from the cylinder. The amount of mass that has escaped and the work done are to be determined.

Assumptions 1 This is an unsteady process since the conditions within the device are changing during the process, but it can be analyzed as a uniform-flow process since the state of fluid leaving the device is assumed to be constant. **2** Kinetic and potential energies are negligible. **3** Air is an ideal gas with constant specific heats at the average temperature.

Properties The properties of air are $R = 0.287 \text{ kPa}\cdot\text{m}^3/\text{kg}\cdot\text{K}$ (Table A-1), $c_v = 0.733 \text{ kJ/kg}\cdot\text{K}$, $c_p = 1.020 \text{ kJ/kg}\cdot\text{K}$ at the anticipated average temperature of 450 K (Table A-2b).

Analysis We take the tank as the system, which is a control volume since mass crosses the boundary. Noting that the microscopic energies of flowing and nonflowing fluids are represented by enthalpy h and internal energy u , respectively, the mass and energy balances for this uniform-flow system can be expressed as

$$\text{Mass balance: } m_{in} - m_{out} = \Delta m_{\text{system}} \rightarrow m_e = m_1 - m_2$$

$$\text{Energy balance: } \underbrace{E_{in} - E_{out}}_{\text{Net energy transfer by heat, work, and mass}} = \underbrace{\Delta E_{\text{system}}}_{\text{Change in internal, kinetic, potential, etc. energies}}$$

$$W_{b,in} - Q_{out} - m_e h_e = m_2 u_2 - m_1 u_1 \quad (\text{since } ke \cong pe \cong 0)$$

$$\text{or } W_{b,in} - Q_{out} - m_e c_p T_e = m_2 c_v T_2 - m_1 c_v T_1$$

The temperature of the air withdrawn from the cylinder is assumed to be the average of initial and final temperatures of the air in the cylinder. That is,

$$T_e = (1/2)(T_1 + T_2) = (1/2)(473 + T_2)$$

The volumes and the masses at the initial and final states and the mass that has escaped from the cylinder are given by

$$V_1 = \frac{m_1 R T_1}{P_1} = \frac{(1.2 \text{ kg})(0.287 \text{ kPa}\cdot\text{m}^3/\text{kg}\cdot\text{K})(200 + 273 \text{ K})}{(700 \text{ kPa})} = 0.2327 \text{ m}^3$$

$$V_2 = 0.80V_1 = (0.80)(0.2327) = 0.1862 \text{ m}^3$$

$$m_2 = \frac{P_2 V_2}{R T_2} = \frac{(600 \text{ kPa})(0.1862 \text{ m}^3)}{(0.287 \text{ kPa}\cdot\text{m}^3/\text{kg}\cdot\text{K})T_2} = \frac{389.18}{T_2} \text{ kg}$$

$$m_e = m_1 - m_2 = \left(1.2 - \frac{389.18}{T_2}\right) \text{ kg}$$

Noting that the pressure remains constant after the piston starts moving, the boundary work is determined from

$$W_{b,in} = P_2 (V_1 - V_2) = (600 \text{ kPa})(0.2327 - 0.1862) \text{ m}^3 = \mathbf{27.9 \text{ kJ}}$$

Substituting,

$$27.9 \text{ kJ} - 40 \text{ kJ} - \left(1.2 - \frac{389.18}{T_2}\right) (1.020 \text{ kJ/kg}\cdot\text{K})(1/2)(473 + T_2)$$

$$= \left(\frac{389.18}{T_2}\right) (0.733 \text{ kJ/kg}\cdot\text{K})T_2 - (1.2 \text{ kg})(0.733 \text{ kJ/kg}\cdot\text{K})(473 \text{ K})$$

The final temperature may be obtained from this equation by a trial-error approach or using EES to be

$$T_2 = \mathbf{415.0 \text{ K}}$$

Then, the amount of mass that has escaped becomes

$$m_e = 1.2 - \frac{389.18}{415.0 \text{ K}} = \mathbf{0.262 \text{ kg}}$$

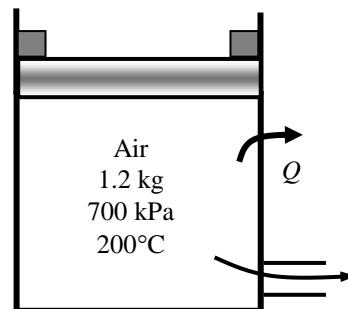

5-186 Geothermal water flows through a flash chamber, a separator, and a turbine in a geothermal power plant. The temperature of the steam after the flashing process and the power output from the turbine are to be determined for different flash chamber exit pressures.

Assumptions 1 This is a steady-flow process since there is no change with time. **2** Kinetic and potential energy changes are negligible. **3** The devices are insulated so that there are no heat losses to the surroundings. **4** Properties of steam are used for geothermal water.

Analysis For all components, we take the steam as the system, which is a control volume since mass crosses the boundary. The energy balance for this steady-flow system can be expressed in the rate form as

Energy balance:

$$\underbrace{\dot{E}_{\text{in}} - \dot{E}_{\text{out}}}_{\substack{\text{Rate of net energy transfer} \\ \text{by heat, work, and mass}}} = \underbrace{\Delta \dot{E}_{\text{system}}}_{\substack{\text{Rate of change in internal, kinetic,} \\ \text{potential, etc. energies}}} \stackrel{\text{no (steady)}}{=} 0$$

$$\dot{E}_{\text{in}} = \dot{E}_{\text{out}}$$

For each component, the energy balance reduces to

Flash chamber: $h_1 = h_2$

Separator: $\dot{m}_2 h_2 = \dot{m}_3 h_3 + \dot{m}_{\text{liquid}} h_{\text{liquid}}$

Turbine: $\dot{W}_T = \dot{m}_3 (h_3 - h_4)$

(a) For a flash chamber exit pressure of $P_2 = 1 \text{ MPa}$

The properties of geothermal water are

$$h_1 = h_{\text{sat}@230^\circ\text{C}} = 990.14 \text{ kJ/kg}$$

$$h_2 = h_1$$

$$x_2 = \frac{h_2 - h_f @ 1000 \text{ kPa}}{h_{fg} @ 1000 \text{ kPa}} = \frac{990.14 - 762.51}{2014.6} = 0.113$$

$$T_2 = T_{\text{sat}@1000 \text{ kPa}} = \mathbf{179.9^\circ\text{C}}$$

$$\left. \begin{array}{l} P_3 = 1000 \text{ kPa} \\ x_3 = 1 \end{array} \right\} h_3 = 2777.1 \text{ kJ/kg}$$

$$\left. \begin{array}{l} P_4 = 20 \text{ kPa} \\ x_4 = 0.95 \end{array} \right\} h_4 = h_f + x_4 h_{fg} = 251.42 + (0.05)(2357.5 \text{ kJ/kg}) = 2491.1 \text{ kJ/kg}$$

The mass flow rate of vapor after the flashing process is

$$\dot{m}_3 = x_2 \dot{m}_2 = (0.113)(50 \text{ kg/s}) = 5.649 \text{ kg/s}$$

Then, the power output from the turbine becomes

$$\dot{W}_T = (5.649 \text{ kg/s})(2777.1 - 2491.1) = \mathbf{1616 \text{ kW}}$$

Repeating the similar calculations for other pressures, we obtain

(b) For $P_2 = 500 \text{ kPa}$, $T_2 = \mathbf{151.8^\circ\text{C}}$, $\dot{W}_T = \mathbf{2134 \text{ kW}}$

(c) For $P_2 = 100 \text{ kPa}$, $T_2 = \mathbf{99.6^\circ\text{C}}$, $\dot{W}_T = \mathbf{2333 \text{ kW}}$

(d) For $P_2 = 50 \text{ kPa}$, $T_2 = \mathbf{81.3^\circ\text{C}}$, $\dot{W}_T = \mathbf{2173 \text{ kW}}$

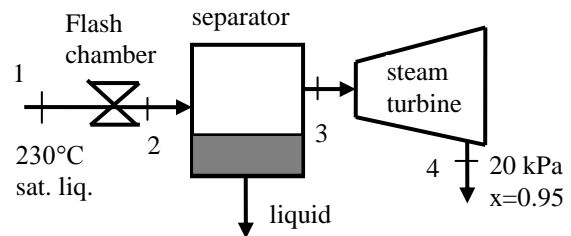

5-187 The turbocharger of an internal combustion engine consisting of a turbine, a compressor, and an aftercooler is considered. The temperature of the air at the compressor outlet and the minimum flow rate of ambient air are to be determined.

Assumptions 1 All processes are steady since there is no change with time. 2 Kinetic and potential energy changes are negligible. 3 Air properties are used for exhaust gases. 4 Air is an ideal gas with constant specific heats. 5 The mechanical efficiency between the turbine and the compressor is 100%. 6 All devices are adiabatic. 7 The local atmospheric pressure is 100 kPa.

Properties The constant pressure specific heats of exhaust gases, warm air, and cold ambient air are taken to be $c_p = 1.063, 1.008, \text{ and } 1.005 \text{ kJ/kg}\cdot\text{K}$, respectively (Table A-2b).

Analysis (a) An energy balance on turbine gives

$$\dot{W}_T = \dot{m}_{\text{exh}} c_{p,\text{exh}} (T_{\text{exh},1} - T_{\text{exh},2}) = (0.02 \text{ kg/s})(1.063 \text{ kJ/kg}\cdot\text{K})(400 - 350)\text{K} = 1.063 \text{ kW}$$

This is also the power input to the compressor since the mechanical efficiency between the turbine and the compressor is assumed to be 100%. An energy balance on the compressor gives the air temperature at the compressor outlet

$$\begin{aligned} \dot{W}_C &= \dot{m}_a c_{p,a} (T_{a,2} - T_{a,1}) \\ 1.063 \text{ kW} &= (0.018 \text{ kg/s})(1.008 \text{ kJ/kg}\cdot\text{K})(T_{a,2} - 50)\text{K} \longrightarrow T_{a,2} = \mathbf{108.6^\circ\text{C}} \end{aligned}$$

(b) An energy balance on the aftercooler gives the mass flow rate of cold ambient air

$$\begin{aligned} \dot{m}_a c_{p,a} (T_{a,2} - T_{a,3}) &= \dot{m}_{\text{ca}} c_{p,\text{ca}} (T_{\text{ca},2} - T_{\text{ca},1}) \\ (0.018 \text{ kg/s})(1.008 \text{ kJ/kg}\cdot^\circ\text{C})(108.6 - 80)^\circ\text{C} &= \dot{m}_{\text{ca}} (1.005 \text{ kJ/kg}\cdot^\circ\text{C})(40 - 30)^\circ\text{C} \\ \dot{m}_{\text{ca}} &= 0.05161 \text{ kg/s} \end{aligned}$$

The volume flow rate may be determined if we first calculate specific volume of cold ambient air at the inlet of aftercooler. That is,

$$\nu_{\text{ca}} = \frac{RT}{P} = \frac{(0.287 \text{ kJ/kg}\cdot\text{K})(30 + 273 \text{ K})}{100 \text{ kPa}} = 0.8696 \text{ m}^3/\text{kg}$$

$$\dot{V}_{\text{ca}} = \dot{m}_{\text{ca}} \nu_{\text{ca}} = (0.05161 \text{ kg/s})(0.8696 \text{ m}^3/\text{kg}) = \mathbf{0.0449 \text{ m}^3/\text{s} = 44.9 \text{ L/s}}$$

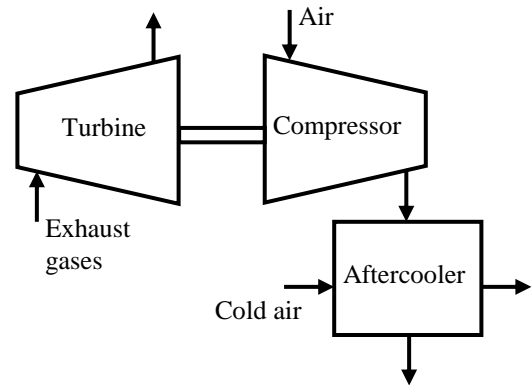

5-188 A building is to be heated by a 30-kW electric resistance heater placed in a duct inside. The time it takes to raise the interior temperature from 14°C to 24°C, and the average mass flow rate of air as it passes through the heater in the duct are to be determined.

Assumptions 1 Steady operating conditions exist. 2 Air is an ideal gas with constant specific heats at room temperature. 3 Kinetic and potential energy changes are negligible. 4 The heating duct is adiabatic, and thus heat transfer through it is negligible. 5 No air leaks in and out of the building.

Properties The gas constant of air is 0.287 kPa·m³/kg·K (Table A-1). The specific heats of air at room temperature are $c_p = 1.005$ and $c_v = 0.718$ kJ/kg·K (Table A-2).

Analysis (a) The total mass of air in the building is

$$m = \frac{P_1 V_1}{RT_1} = \frac{(95 \text{ kPa})(400 \text{ m}^3)}{(0.287 \text{ kPa} \cdot \text{m}^3/\text{kg} \cdot \text{K})(287 \text{ K})} = 461.3 \text{ kg}.$$

We first take the *entire building* as our system, which is a closed system since no mass leaks in or out. The time required to raise the air temperature to 24°C is determined by applying the energy balance to this constant volume closed system:

$$\begin{aligned} \underbrace{E_{\text{in}} - E_{\text{out}}}_{\substack{\text{Net energy transfer} \\ \text{by heat, work, and mass}}} &= \underbrace{\Delta E_{\text{system}}}_{\substack{\text{Change in internal, kinetic,} \\ \text{potential, etc. energies}}} \\ W_{\text{e,in}} + W_{\text{fan,in}} - Q_{\text{out}} &= \Delta U \quad (\text{since } \Delta \text{KE} = \Delta \text{PE} = 0) \\ \Delta t (\dot{W}_{\text{e,in}} + \dot{W}_{\text{fan,in}} - \dot{Q}_{\text{out}}) &= mc_{v,\text{avg}}(T_2 - T_1) \end{aligned}$$

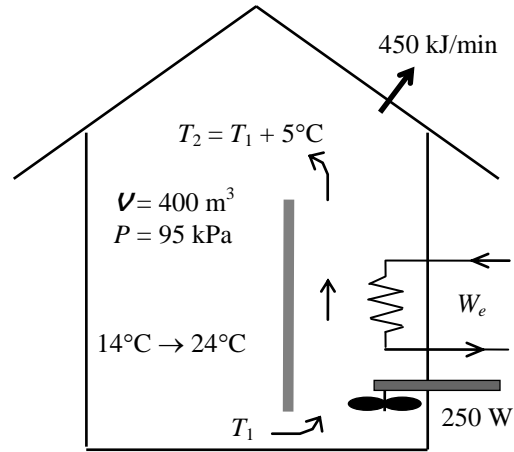

Solving for Δt gives

$$\Delta t = \frac{mc_{v,\text{avg}}(T_2 - T_1)}{\dot{W}_{\text{e,in}} + \dot{W}_{\text{fan,in}} - \dot{Q}_{\text{out}}} = \frac{(461.3 \text{ kg})(0.718 \text{ kJ/kg} \cdot \text{C})(24 - 14)^\circ \text{C}}{(30 \text{ kJ/s}) + (0.25 \text{ kJ/s}) - (450/60 \text{ kJ/s})} = \mathbf{146 \text{ s}}$$

(b) We now take the *heating duct* as the system, which is a control volume since mass crosses the boundary. There is only one inlet and one exit, and thus $\dot{m}_1 = \dot{m}_2 = \dot{m}$. The energy balance for this adiabatic steady-flow system can be expressed in the rate form as

$$\begin{aligned} \underbrace{\dot{E}_{\text{in}} - \dot{E}_{\text{out}}}_{\substack{\text{Rate of net energy transfer} \\ \text{by heat, work, and mass}}} &= \underbrace{\dot{\Delta E}_{\text{system}}}_{\substack{\text{Rate of change in internal, kinetic,} \\ \text{potential, etc. energies}}} \stackrel{\approx 0 \text{ (steady)}}{=} 0 \\ \dot{E}_{\text{in}} &= \dot{E}_{\text{out}} \\ \dot{W}_{\text{e,in}} + \dot{W}_{\text{fan,in}} + \dot{m}h_1 &= \dot{m}h_2 \quad (\text{since } \dot{Q} = \Delta ke \cong \Delta pe \cong 0) \\ \dot{W}_{\text{e,in}} + \dot{W}_{\text{fan,in}} &= \dot{m}(h_2 - h_1) = \dot{m}c_p(T_2 - T_1) \end{aligned}$$

Thus,

$$\dot{m} = \frac{\dot{W}_{\text{e,in}} + \dot{W}_{\text{fan,in}}}{c_p \Delta T} = \frac{(30 + 0.25) \text{ kJ/s}}{(1.005 \text{ kJ/kg} \cdot \text{C})(5^\circ \text{C})} = \mathbf{6.02 \text{ kg/s}}$$

5-189 A water tank open to the atmosphere is initially filled with water. The tank discharges to the atmosphere through a long pipe connected to a valve. The initial discharge velocity from the tank and the time required to empty the tank are to be determined.

Assumptions 1 The flow is incompressible. **2** The draining pipe is horizontal. **3** The tank is considered to be empty when the water level drops to the center of the valve.

Analysis (a) Substituting the known quantities, the discharge velocity can be expressed as

$$V = \sqrt{\frac{2gz}{1.5 + fL/D}} = \sqrt{\frac{2gz}{1.5 + 0.015(100\text{ m})/(0.10\text{ m})}} = \sqrt{0.1212gz}$$

Then the initial discharge velocity becomes

$$V_1 = \sqrt{0.1212gz_1} = \sqrt{0.1212(9.81\text{ m/s}^2)(2\text{ m})} = \mathbf{1.54\text{ m/s}}$$

where z is the water height relative to the center of the orifice at that time.

(b) The flow rate of water from the tank can be obtained by multiplying the discharge velocity by the pipe cross-sectional area,

$$\dot{V} = A_{\text{pipe}}V_2 = \frac{\pi D^2}{4} \sqrt{0.1212gz}$$

Then the amount of water that flows through the pipe during a differential time interval dt is

$$dV = \dot{V}dt = \frac{\pi D^2}{4} \sqrt{0.1212gz} dt \quad (1)$$

which, from conservation of mass, must be equal to the decrease in the volume of water in the tank,

$$dV = A_{\text{tank}}(-dz) = -\frac{\pi D_0^2}{4} dz \quad (2)$$

where dz is the change in the water level in the tank during dt . (Note that dz is a negative quantity since the positive direction of z is upwards. Therefore, we used $-dz$ to get a positive quantity for the amount of water discharged). Setting Eqs. (1) and (2) equal to each other and rearranging,

$$\frac{\pi D^2}{4} \sqrt{0.1212gz} dt = -\frac{\pi D_0^2}{4} dz \rightarrow dt = -\frac{D_0^2}{D^2} \frac{dz}{\sqrt{0.1212gz}} = -\frac{D_0^2}{D^2 \sqrt{0.1212g}} z^{-1/2} dz$$

The last relation can be integrated easily since the variables are separated. Letting t_f be the discharge time and integrating it from $t = 0$ when $z = z_1$ to $t = t_f$ when $z = 0$ (completely drained tank) gives

$$\int_{t=0}^{t_f} dt = -\frac{D_0^2}{D^2 \sqrt{0.1212g}} \int_{z=z_1}^0 z^{-1/2} dz \rightarrow t_f = -\frac{D_0^2}{D^2 \sqrt{0.1212g}} \left[\frac{z^{1/2}}{1/2} \right]_{z_1}^0 = \frac{2D_0^2}{D^2 \sqrt{0.1212g}} z_1^{1/2}$$

Simplifying and substituting the values given, the draining time is determined to be

$$t_f = \frac{2D_0^2}{D^2} \sqrt{\frac{z_1}{0.1212g}} = \frac{2(10\text{ m})^2}{(0.1\text{ m})^2} \sqrt{\frac{2\text{ m}}{0.1212(9.81\text{ m/s}^2)}} = 25,940\text{ s} = \mathbf{7.21\text{ h}}$$

Discussion The draining time can be shortened considerably by installing a pump in the pipe.

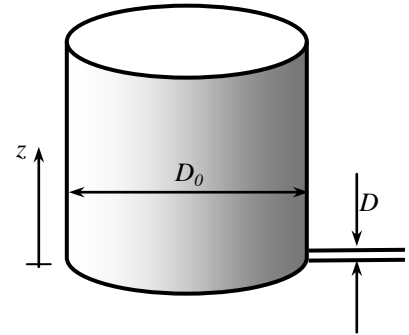

5-190 A fluid is flowing in a circular pipe. A relation is to be obtained for the average fluid velocity in terms of $V(r)$, R , and r .

Analysis Choosing a circular ring of area $dA = 2\pi r dr$ as our differential area, the mass flow rate through a cross-sectional area can be expressed as

$$\dot{m} = \int_A \rho V(r) dA = \int_0^R \rho V(r) 2\pi r dr$$

Solving for V_{avg} ,

$$V_{\text{avg}} = \frac{2}{R^2} \int_0^R V(r) r dr$$

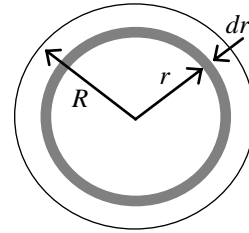

5-191 Two streams of same ideal gas at different states are mixed in a mixing chamber. The simplest expression for the mixture temperature in a specified format is to be obtained.

Analysis The energy balance for this steady-flow system can be expressed in the rate form as

$$\underbrace{\dot{E}_{\text{in}} - \dot{E}_{\text{out}}}_{\text{Rate of net energy transfer by heat, work, and mass}} = \underbrace{\Delta \dot{E}_{\text{system}}}_{\text{Rate of change in internal, kinetic, potential, etc. energies}} \stackrel{\text{no (steady)}}{=} 0$$

$$\dot{E}_{\text{in}} = \dot{E}_{\text{out}}$$

$$\dot{m}_1 h_1 + \dot{m}_2 h_2 = \dot{m}_3 h_3 \quad (\text{since } \dot{Q} = \dot{W} = 0)$$

$$\dot{m}_1 c_p T_1 + \dot{m}_2 c_p T_2 = \dot{m}_3 c_p T_3$$

and,

$$\dot{m}_3 = \dot{m}_1 + \dot{m}_2$$

Solving for final temperature, we find

$$T_3 = \frac{\dot{m}_1}{\dot{m}_3} T_1 + \frac{\dot{m}_2}{\dot{m}_3} T_2$$



Fundamentals of Engineering (FE) Exam Problems

5-192 Steam is compressed by an adiabatic compressor from 0.2 MPa and 150°C to 2500 MPa and 250°C at a rate of 1.30 kg/s. The power input to the compressor is

- (a) 144 kW (b) 234 kW (c) 438 kW (d) 717 kW (e) 901 kW

Answer (a) 144 kW

Solution Solved by EES Software. Solutions can be verified by copying-and-pasting the following lines on a blank EES screen. (Similar problems and their solutions can be obtained easily by modifying numerical values).

"Note: This compressor violates the 2nd law. Changing State 2 to 800 kPa and 350C will correct this problem (it would give 511 kW)"

P1=200 "kPa"

T1=150 "C"

P2=2500 "kPa"

T2=250 "C"

m_dot=1.30 "kg/s"

Q_dot_loss=0 "kJ/s"

h1=ENTHALPY(Steam_IAPWS,T=T1,P=P1)

h2=ENTHALPY(Steam_IAPWS,T=T2,P=P2)

"The rate form of energy balance for a steady-flow system is $E_{\dot{in}} = E_{\dot{out}}$ "

$W_{\dot{in}} - Q_{\dot{loss}} = m_{\dot{}}(h_2 - h_1)$

"Some Wrong Solutions with Common Mistakes:"

W1_Win-Q_dot_loss=(h2-h1)/m_dot "Dividing by mass flow rate instead of multiplying"

W2_Win-Q_dot_loss=h2-h1 "Not considering mass flow rate"

u1=INTENERGY(Steam_IAPWS,T=T1,P=P1)

u2=INTENERGY(Steam_IAPWS,T=T2,P=P2)

W3_Win-Q_dot_loss=m_dot*(u2-u1) "Using internal energy instead of enthalpy"

W4_Win-Q_dot_loss=u2-u1 "Using internal energy and ignoring mass flow rate"

5-193 Steam enters a diffuser steadily at 0.5 MPa, 300°C, and 122 m/s at a rate of 3.5 kg/s. The inlet area of the diffuser is

- (a) 15 cm² (b) 50 cm² (c) 105 cm² (d) 150 cm² (e) 190 cm²

Answer (d) 150 cm²

Solution Solved by EES Software. Solutions can be verified by copying-and-pasting the following lines on a blank EES screen. (Similar problems and their solutions can be obtained easily by modifying numerical values).

```
Vel_1=122 "m/s"
m=3.5 "kg/s"
T1=300 "C"
P1=500 "kPa"
"The rate form of energy balance is E_dot_in - E_dot_out = DELTAE_dot_cv"
v1=VOLUME(Steam_IAPWS,T=T1,P=P1)
m=(1/v1)*A*Vel_1 "A in m^2"
```

"Some Wrong Solutions with Common Mistakes:"

```
R=0.4615 "kJ/kg.K"
P1*v1ideal=R*(T1+273)
m=(1/v1ideal)*W1_A*Vel_1 "assuming ideal gas"
P1*v2ideal=R*T1
m=(1/v2ideal)*W2_A*Vel_1 "assuming ideal gas and using C"
m=W3_A*Vel_1 "not using specific volume"
```

5-194 An adiabatic heat exchanger is used to heat cold water at 15°C entering at a rate of 5 kg/s by hot air at 90°C entering also at rate of 5 kg/s. If the exit temperature of hot air is 20°C, the exit temperature of cold water is

- (a) 27°C (b) 32°C (c) 52°C (d) 85°C (e) 90°C

Answer (b) 32°C

Solution Solved by EES Software. Solutions can be verified by copying-and-pasting the following lines on a blank EES screen. (Similar problems and their solutions can be obtained easily by modifying numerical values).

```
C_w=4.18 "kJ/kg-C"
Cp_air=1.005 "kJ/kg-C"
Tw1=15 "C"
m_dot_w=5 "kg/s"
Tair1=90 "C"
Tair2=20 "C"
m_dot_air=5 "kg/s"
"The rate form of energy balance for a steady-flow system is E_dot_in = E_dot_out"
m_dot_air*Cp_air*(Tair1-Tair2)=m_dot_w*C_w*(Tw2-Tw1)
```

"Some Wrong Solutions with Common Mistakes:"

```
(Tair1-Tair2)=(W1_Tw2-Tw1) "Equating temperature changes of fluids"
Cv_air=0.718 "kJ/kg.K"
m_dot_air*Cv_air*(Tair1-Tair2)=m_dot_w*C_w*(W2_Tw2-Tw1) "Using Cv for air"
W3_Tw2=Tair1 "Setting inlet temperature of hot fluid = exit temperature of cold fluid"
W4_Tw2=Tair2 "Setting exit temperature of hot fluid = exit temperature of cold fluid"
```

5-195 A heat exchanger is used to heat cold water at 15°C entering at a rate of 2 kg/s by hot air at 85°C entering at rate of 3 kg/s. The heat exchanger is not insulated, and is losing heat at a rate of 25 kJ/s. If the exit temperature of hot air is 20°C, the exit temperature of cold water is

- (a) 28°C (b) 35°C (c) 38°C (d) 41°C (e) 80°C

Answer (b) 35°C

Solution Solved by EES Software. Solutions can be verified by copying-and-pasting the following lines on a blank EES screen. (Similar problems and their solutions can be obtained easily by modifying numerical values).

$C_w=4.18$ "kJ/kg-C"

$Cp_{air}=1.005$ "kJ/kg-C"

$T_{w1}=15$ "C"

$m_{dot_w}=2$ "kg/s"

$T_{air1}=85$ "C"

$T_{air2}=20$ "C"

$m_{dot_{air}}=3$ "kg/s"

$Q_{loss}=25$ "kJ/s"

"The rate form of energy balance for a steady-flow system is $E_{dot_{in}} = E_{dot_{out}}$ "

$m_{dot_{air}}*Cp_{air}*(T_{air1}-T_{air2})=m_{dot_w}*C_w*(T_{w2}-T_{w1})+Q_{loss}$

"Some Wrong Solutions with Common Mistakes:"

$m_{dot_{air}}*Cp_{air}*(T_{air1}-T_{air2})=m_{dot_w}*C_w*(T_{w1}-T_{w2})$ "Not considering Q_{loss} "

$m_{dot_{air}}*Cp_{air}*(T_{air1}-T_{air2})=m_{dot_w}*C_w*(T_{w2}-T_{w1})-Q_{loss}$ "Taking heat loss as heat gain"

$(T_{air1}-T_{air2})=(T_{w3}-T_{w2}-T_{w1})$ "Equating temperature changes of fluids"

$Cv_{air}=0.718$ "kJ/kg.K"

$m_{dot_{air}}*Cv_{air}*(T_{air1}-T_{air2})=m_{dot_w}*C_w*(T_{w4}-T_{w2}-T_{w1})+Q_{loss}$ "Using Cv for air"

5-196 An adiabatic heat exchanger is used to heat cold water at 15°C entering at a rate of 5 kg/s by hot water at 90°C entering at rate of 4 kg/s. If the exit temperature of hot water is 50°C, the exit temperature of cold water is

- (a) 42°C (b) 47°C (c) 55°C (d) 78°C (e) 90°C

Answer (b) 47°C

Solution Solved by EES Software. Solutions can be verified by copying-and-pasting the following lines on a blank EES screen. (Similar problems and their solutions can be obtained easily by modifying numerical values).

$C_w=4.18$ "kJ/kg-C"

$T_{cold_1}=15$ "C"

$m_{dot_{cold}}=5$ "kg/s"

$T_{hot_1}=90$ "C"

$T_{hot_2}=50$ "C"

$m_{dot_{hot}}=4$ "kg/s"

$Q_{loss}=0$ "kJ/s"

"The rate form of energy balance for a steady-flow system is $E_{dot_{in}} = E_{dot_{out}}$ "

$m_{dot_{hot}}*C_w*(T_{hot_1}-T_{hot_2})=m_{dot_{cold}}*C_w*(T_{cold_2}-T_{cold_1})+Q_{loss}$

"Some Wrong Solutions with Common Mistakes:"

$T_{hot_1}-T_{hot_2}=T_{cold_2}-T_{cold_1}$ "Equating temperature changes of fluids"

$T_{cold_2}=90$ "Taking exit temp of cold fluid=inlet temp of hot fluid"

5-197 In a shower, cold water at 10°C flowing at a rate of 5 kg/min is mixed with hot water at 60°C flowing at a rate of 2 kg/min. The exit temperature of the mixture will be

- (a) 24.3°C (b) 35.0°C (c) 40.0°C (d) 44.3°C (e) 55.2°C

Answer (a) 24.3°C

Solution Solved by EES Software. Solutions can be verified by copying-and-pasting the following lines on a blank EES screen. (Similar problems and their solutions can be obtained easily by modifying numerical values).

$C_w=4.18$ "kJ/kg-C"

$T_{cold_1}=10$ "C"

$m_{dot_cold}=5$ "kg/min"

$T_{hot_1}=60$ "C"

$m_{dot_hot}=2$ "kg/min"

"The rate form of energy balance for a steady-flow system is $E_{dot_in} = E_{dot_out}$ "

$m_{dot_hot} * C_w * T_{hot_1} + m_{dot_cold} * C_w * T_{cold_1} = (m_{dot_hot} + m_{dot_cold}) * C_w * T_{mix}$

"Some Wrong Solutions with Common Mistakes:"

$W1_T_{mix} = (T_{cold_1} + T_{hot_1}) / 2$ "Taking the average temperature of inlet fluids"

5-198 In a heating system, cold outdoor air at 7°C flowing at a rate of 4 kg/min is mixed adiabatically with heated air at 70°C flowing at a rate of 3 kg/min. The exit temperature of the mixture is

- (a) 34°C (b) 39°C (c) 45°C (d) 63°C (e) 77°C

Answer (a) 34°C

Solution Solved by EES Software. Solutions can be verified by copying-and-pasting the following lines on a blank EES screen. (Similar problems and their solutions can be obtained easily by modifying numerical values).

$C_{air}=1.005$ "kJ/kg-C"

$T_{cold_1}=7$ "C"

$m_{dot_cold}=4$ "kg/min"

$T_{hot_1}=70$ "C"

$m_{dot_hot}=3$ "kg/min"

"The rate form of energy balance for a steady-flow system is $E_{dot_in} = E_{dot_out}$ "

$m_{dot_hot} * C_{air} * T_{hot_1} + m_{dot_cold} * C_{air} * T_{cold_1} = (m_{dot_hot} + m_{dot_cold}) * C_{air} * T_{mix}$

"Some Wrong Solutions with Common Mistakes:"

$W1_T_{mix} = (T_{cold_1} + T_{hot_1}) / 2$ "Taking the average temperature of inlet fluids"

5-199 Hot combustion gases (assumed to have the properties of air at room temperature) enter a gas turbine at 1 MPa and 1500 K at a rate of 0.1 kg/s, and exit at 0.2 MPa and 900 K. If heat is lost from the turbine to the surroundings at a rate of 15 kJ/s, the power output of the gas turbine is

- (a) 15 kW (b) 30 kW (c) 45 kW (d) 60 kW (e) 75 kW

Answer (c) 45 kW

Solution Solved by EES Software. Solutions can be verified by copying-and-pasting the following lines on a blank EES screen. (Similar problems and their solutions can be obtained easily by modifying numerical values).

Cp_air=1.005 "kJ/kg-C"

T1=1500 "K"

T2=900 "K"

m_dot=0.1 "kg/s"

Q_dot_loss=15 "kJ/s"

"The rate form of energy balance for a steady-flow system is E_dot_in = E_dot_out"

W_dot_out+Q_dot_loss=m_dot*Cp_air*(T1-T2)

"Alternative: Variable specific heats - using EES data"

W_dot_outvariable+Q_dot_loss=m_dot*(ENTHALPY(Air,T=T1)-ENTHALPY(Air,T=T2))

"Some Wrong Solutions with Common Mistakes:"

W1_Wout=m_dot*Cp_air*(T1-T2) "Disregarding heat loss"

W2_Wout-Q_dot_loss=m_dot*Cp_air*(T1-T2) "Assuming heat gain instead of loss"

5-200 Steam expands in a turbine from 4 MPa and 500°C to 0.5 MPa and 250°C at a rate of 1350 kg/h. Heat is lost from the turbine at a rate of 25 kJ/s during the process. The power output of the turbine is

- (a) 157 kW (b) 207 kW (c) 182 kW (d) 287 kW (e) 246 kW

Answer (a) 157 kW

Solution Solved by EES Software. Solutions can be verified by copying-and-pasting the following lines on a blank EES screen. (Similar problems and their solutions can be obtained easily by modifying numerical values).

T1=500 "C"

P1=4000 "kPa"

T2=250 "C"

P2=500 "kPa"

m_dot=1350/3600 "kg/s"

Q_dot_loss=25 "kJ/s"

h1=ENTHALPY(Steam_IAPWS,T=T1,P=P1)

h2=ENTHALPY(Steam_IAPWS,T=T2,P=P2)

"The rate form of energy balance for a steady-flow system is E_dot_in = E_dot_out"

W_dot_out+Q_dot_loss=m_dot*(h1-h2)

"Some Wrong Solutions with Common Mistakes:"

W1_Wout=m_dot*(h1-h2) "Disregarding heat loss"

W2_Wout-Q_dot_loss=m_dot*(h1-h2) "Assuming heat gain instead of loss"

u1=INTENERGY(Steam_IAPWS,T=T1,P=P1)

u2=INTENERGY(Steam_IAPWS,T=T2,P=P2)

W3_Wout+Q_dot_loss=m_dot*(u1-u2) "Using internal energy instead of enthalpy"

W4_Wout-Q_dot_loss=m_dot*(u1-u2) "Using internal energy and wrong direction for heat"

5-201 Steam is compressed by an adiabatic compressor from 0.2 MPa and 150°C to 0.8 MPa and 350°C at a rate of 1.30 kg/s. The power input to the compressor is

- (a) 511 kW (b) 393 kW (c) 302 kW (d) 717 kW (e) 901 kW

Answer (a) 511 kW

Solution Solved by EES Software. Solutions can be verified by copying-and-pasting the following lines on a blank EES screen. (Similar problems and their solutions can be obtained easily by modifying numerical values).

```
P1=200 "kPa"
T1=150 "C"
P2=800 "kPa"
T2=350 "C"
m_dot=1.30 "kg/s"
Q_dot_loss=0 "kJ/s"
h1=ENTHALPY(Steam_IAPWS,T=T1,P=P1)
h2=ENTHALPY(Steam_IAPWS,T=T2,P=P2)
"The rate form of energy balance for a steady-flow system is E_dot_in = E_dot_out"
W_dot_in-Q_dot_loss=m_dot*(h2-h1)
```

"Some Wrong Solutions with Common Mistakes:"

```
W1_Win-Q_dot_loss=(h2-h1)/m_dot "Dividing by mass flow rate instead of multiplying"
W2_Win-Q_dot_loss=h2-h1 "Not considering mass flow rate"
u1=INTENERGY(Steam_IAPWS,T=T1,P=P1)
u2=INTENERGY(Steam_IAPWS,T=T2,P=P2)
W3_Win-Q_dot_loss=m_dot*(u2-u1) "Using internal energy instead of enthalpy"
W4_Win-Q_dot_loss=u2-u1 "Using internal energy and ignoring mass flow rate"
```

5-202 Refrigerant-134a is compressed by a compressor from the saturated vapor state at 0.14 MPa to 0.9 MPa and 60°C at a rate of 0.108 kg/s. The refrigerant is cooled at a rate of 1.10 kJ/s during compression. The power input to the compressor is

- (a) 4.94 kW (b) 6.04 kW (c) 7.14 kW (d) 7.50 kW (e) 8.13 kW

Answer (c) 7.14 kW

Solution Solved by EES Software. Solutions can be verified by copying-and-pasting the following lines on a blank EES screen. (Similar problems and their solutions can be obtained easily by modifying numerical values).

```
P1=140 "kPa"
x1=1
P2=900 "kPa"
T2=60 "C"
m_dot=0.108 "kg/s"
Q_dot_loss=1.10 "kJ/s"
h1=ENTHALPY(R134a,x=x1,P=P1)
h2=ENTHALPY(R134a,T=T2,P=P2)
"The rate form of energy balance for a steady-flow system is E_dot_in = E_dot_out"
W_dot_in-Q_dot_loss=m_dot*(h2-h1)
```

"Some Wrong Solutions with Common Mistakes:"

```
W1_Win+Q_dot_loss=m_dot*(h2-h1) "Wrong direction for heat transfer"
W2_Win =m_dot*(h2-h1) "Not considering heat loss"
u1=INTENERGY(R134a,x=x1,P=P1)
u2=INTENERGY(R134a,T=T2,P=P2)
W3_Win-Q_dot_loss=m_dot*(u2-u1) "Using internal energy instead of enthalpy"
W4_Win+Q_dot_loss=u2-u1 "Using internal energy and wrong direction for heat transfer"
```

5-203 Refrigerant-134a expands in an adiabatic turbine from 1.2 MPa and 100°C to 0.18 MPa and 50°C at a rate of 1.25 kg/s. The power output of the turbine is

- (a) 44.7 kW (b) 66.4 kW (c) 72.7 kW (d) 89.2 kW (e) 112.0 kW

Answer (a) 44.7 kW

Solution Solved by EES Software. Solutions can be verified by copying-and-pasting the following lines on a blank EES screen. (Similar problems and their solutions can be obtained easily by modifying numerical values).

```
P1=1200 "kPa"
T1=100 "C"
P2=180 "kPa"
T2=50 "C"
m_dot=1.25 "kg/s"
Q_dot_loss=0 "kJ/s"
h1=ENTHALPY(R134a,T=T1,P=P1)
h2=ENTHALPY(R134a,T=T2,P=P2)
"The rate form of energy balance for a steady-flow system is E_dot_in = E_dot_out"
-W_dot_out-Q_dot_loss=m_dot*(h2-h1)
```

"Some Wrong Solutions with Common Mistakes:"

```
-W1_Wout-Q_dot_loss=(h2-h1)/m_dot "Dividing by mass flow rate instead of multiplying"
-W2_Wout-Q_dot_loss=h2-h1 "Not considering mass flow rate"
u1=INTENERGY(R134a,T=T1,P=P1)
u2=INTENERGY(R134a,T=T2,P=P2)
-W3_Wout-Q_dot_loss=m_dot*(u2-u1) "Using internal energy instead of enthalpy"
-W4_Wout-Q_dot_loss=u2-u1 "Using internal energy and ignoring mass flow rate"
```

5-204 Refrigerant-134a at 1.4 MPa and 90°C is throttled to a pressure of 0.6 MPa. The temperature of the refrigerant after throttling is

- (a) 22°C (b) 56°C (c) 82°C (d) 80°C (e) 90.0°C

Answer (d) 80°C

Solution Solved by EES Software. Solutions can be verified by copying-and-pasting the following lines on a blank EES screen. (Similar problems and their solutions can be obtained easily by modifying numerical values).

```
P1=1400 "kPa"
T1=90 "C"
P2=600 "kPa"
h1=ENTHALPY(R134a,T=T1,P=P1)
T2=TEMPERATURE(R134a,h=h1,P=P2)
```

"Some Wrong Solutions with Common Mistakes:"

```
W1_T2=T1 "Assuming the temperature to remain constant"
W2_T2=TEMPERATURE(R134a,x=0,P=P2) "Taking the temperature to be the saturation temperature at P2"
u1=INTENERGY(R134a,T=T1,P=P1)
W3_T2=TEMPERATURE(R134a,u=u1,P=P2) "Assuming u=constant"
v1=VOLUME(R134a,T=T1,P=P1)
W4_T2=TEMPERATURE(R134a,v=v1,P=P2) "Assuming v=constant"
```

5-205 Air at 27°C and 5 atm is throttled by a valve to 1 atm. If the valve is adiabatic and the change in kinetic energy is negligible, the exit temperature of air will be

- (a) 10°C (b) 15°C (c) 20°C (d) 23°C (e) 27°C

Answer (e) 27°C

Solution Solved by EES Software. Solutions can be verified by copying-and-pasting the following lines on a blank EES screen. (Similar problems and their solutions can be obtained easily by modifying numerical values).

"The temperature of an ideal gas remains constant during throttling, and thus $T_2=T_1$ "

$T_1=27$ "C"

$P_1=5$ "atm"

$P_2=1$ "atm"

$T_2=T_1$ "C"

"Some Wrong Solutions with Common Mistakes:"

$W1_T_2=T_1*P_1/P_2$ "Assuming $v=\text{constant}$ and using C"

$W2_T_2=(T_1+273)*P_1/P_2-273$ "Assuming $v=\text{constant}$ and using K"

$W3_T_2=T_1*P_2/P_1$ "Assuming $v=\text{constant}$ and pressures backwards and using C"

$W4_T_2=(T_1+273)*P_2/P_1$ "Assuming $v=\text{constant}$ and pressures backwards and using K"

5-206 Steam at 1 MPa and 300°C is throttled adiabatically to a pressure of 0.4 MPa. If the change in kinetic energy is negligible, the specific volume of the steam after throttling will be

- (a) 0.358 m³/kg (b) 0.233 m³/kg (c) 0.375 m³/kg (d) 0.646 m³/kg (e) 0.655 m³/kg

Answer (d) 0.646 m³/kg

Solution Solved by EES Software. Solutions can be verified by copying-and-pasting the following lines on a blank EES screen. (Similar problems and their solutions can be obtained easily by modifying numerical values).

$P_1=1000$ "kPa"

$T_1=300$ "C"

$P_2=400$ "kPa"

$h_1=\text{ENTHALPY}(\text{Steam_IAPWS}, T=T_1, P=P_1)$

$v_2=\text{VOLUME}(\text{Steam_IAPWS}, h=h_1, P=P_2)$

"Some Wrong Solutions with Common Mistakes:"

$W1_v_2=\text{VOLUME}(\text{Steam_IAPWS}, T=T_1, P=P_2)$ "Assuming the volume to remain constant"

$u_1=\text{INTENERGY}(\text{Steam}, T=T_1, P=P_1)$

$W2_v_2=\text{VOLUME}(\text{Steam_IAPWS}, u=u_1, P=P_2)$ "Assuming $u=\text{constant}$ "

$W3_v_2=\text{VOLUME}(\text{Steam_IAPWS}, T=T_1, P=P_2)$ "Assuming $T=\text{constant}$ "

5-207 Air is to be heated steadily by an 8-kW electric resistance heater as it flows through an insulated duct. If the air enters at 50°C at a rate of 2 kg/s, the exit temperature of air will be

- (a) 46.0°C (b) 50.0°C (c) 54.0°C (d) 55.4°C (e) 58.0°C

Answer (c) 54.0°C

Solution Solved by EES Software. Solutions can be verified by copying-and-pasting the following lines on a blank EES screen. (Similar problems and their solutions can be obtained easily by modifying numerical values).

$C_p=1.005$ "kJ/kg-C"

$T_1=50$ "C"

$m_{\dot{}}=2$ "kg/s"

$W_{\dot{}}_e=8$ "kJ/s"

$W_{\dot{}}_e=m_{\dot{}}*C_p*(T_2-T_1)$

"Checking using data from EES table"

$W_{\dot{}}_e=m_{\dot{}}*(ENTHALPY(Air,T=T_2table)-ENTHALPY(Air,T=T_1))$

"Some Wrong Solutions with Common Mistakes:"

$C_v=0.718$ "kJ/kg.K"

$W_{\dot{}}_e=C_p*(W_1_{T_2}-T_1)$ "Not using mass flow rate"

$W_{\dot{}}_e=m_{\dot{}}*C_v*(W_2_{T_2}-T_1)$ "Using C_v "

$W_{\dot{}}_e=m_{\dot{}}*C_p*W_3_{T_2}$ "Ignoring T_1 "

5-208 ... 5-212 Design and Essay Problems



Solutions Manual for
Thermodynamics: An Engineering Approach
8th Edition
Yunus A. Çengel, Michael A. Boles
McGraw-Hill, 2015

Chapter 6

THE SECOND LAW OF THERMODYNAMICS

PROPRIETARY AND CONFIDENTIAL

This Manual is the proprietary property of McGraw-Hill Education and protected by copyright and other state and federal laws. By opening and using this Manual the user agrees to the following restrictions, and if the recipient does not agree to these restrictions, the Manual should be promptly returned unopened to McGraw-Hill Education: **This Manual is being provided only to authorized professors and instructors for use in preparing for the classes using the affiliated textbook. No other use or distribution of this Manual is permitted. This Manual may not be sold and may not be distributed to or used by any student or other third party. No part of this Manual may be reproduced, displayed or distributed in any form or by any means, electronic or otherwise, without the prior written permission of McGraw-Hill Education.**

The Second Law of Thermodynamics and Thermal Energy Reservoirs

6-1C Transferring 5 kWh of heat to an electric resistance wire and producing 6 kWh of electricity.

6-2C Transferring 5 kWh of heat to an electric resistance wire and producing 5 kWh of electricity.

6-3C An electric resistance heater which consumes 5 kWh of electricity and supplies 6 kWh of heat to a room.

6-4C No. Heat cannot flow from a low-temperature medium to a higher temperature medium.

6-5C A thermal-energy reservoir is a body that can supply or absorb finite quantities of heat isothermally. Some examples are the oceans, the lakes, and the atmosphere.

6-6C Yes. Because the temperature of the oven remains constant no matter how much heat is transferred to the potatoes.

Heat Engines and Thermal Efficiency

6-7C Heat engines are cyclic devices that receive heat from a source, convert some of it to work, and reject the rest to a sink.

6-8C It is expressed as "No heat engine can exchange heat with a single reservoir, and produce an equivalent amount of work".

6-9C No. Such an engine violates the Kelvin-Planck statement of the second law of thermodynamics.

6-10C No. Because 100% of the work can be converted to heat.

6-11C (a) No, (b) Yes. According to the second law, no heat engine can have an efficiency of 100%.

6-12C No. Such an engine violates the Kelvin-Planck statement of the second law of thermodynamics.

6-13C No. The Kelvin-Planck limitation applies only to heat engines; engines that receive heat and convert some of it to work.

6-14C Method (b). With the heating element in the water, heat losses to the surrounding air are minimized, and thus the desired heating can be achieved with less electrical energy input.

6-15 The rates of heat supply and heat rejection of a power plant are given. The power output and the thermal efficiency of this power plant are to be determined.

Assumptions 1 The plant operates steadily. 2 Heat losses from the working fluid at the pipes and other components are taken into consideration.

Analysis (a) The total heat rejected by this power plant is

$$\dot{Q}_L = 145 + 8 = 153 \text{ GJ/h}$$

Then the net power output of the plant becomes

$$\dot{W}_{\text{net,out}} = \dot{Q}_H - \dot{Q}_L = 280 - 153 = 127 \text{ GJ/h} = \mathbf{35.3 \text{ MW}}$$

(b) The thermal efficiency of the plant is determined from its definition,

$$\eta_{\text{th}} = \frac{\dot{W}_{\text{net,out}}}{\dot{Q}_H} = \frac{127 \text{ GJ/h}}{280 \text{ GJ/h}} = 0.454 = \mathbf{45.4\%}$$

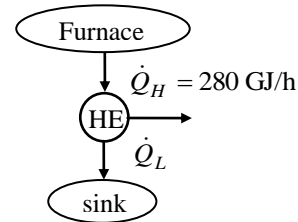

6-16E The power output and thermal efficiency of a car engine are given. The rate of fuel consumption is to be determined.

Assumptions The car operates steadily.

Properties The heating value of the fuel is given to be 19,000 Btu/lbm.

Analysis This car engine is converting 28% of the chemical energy released during the combustion process into work. The amount of energy input required to produce a power output of 110 hp is determined from the definition of thermal efficiency to be

$$\dot{Q}_H = \frac{\dot{W}_{\text{net,out}}}{\eta_{\text{th}}} = \frac{110 \text{ hp}}{0.28} \left(\frac{2545 \text{ Btu/h}}{1 \text{ hp}} \right) = 999,598 \text{ Btu/h}$$

To supply energy at this rate, the engine must burn fuel at a rate of

$$\dot{m} = \frac{999,598 \text{ Btu/h}}{19,000 \text{ Btu/lbm}} = \mathbf{52.6 \text{ lbm/h}}$$

since 19,000 Btu of thermal energy is released for each lbm of fuel burned.

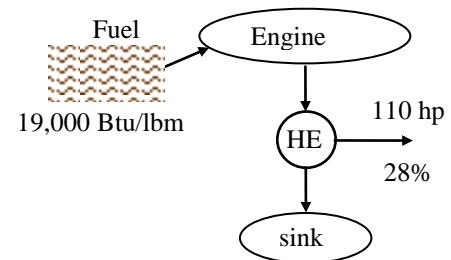

6-17E The rate of heat input and thermal efficiency of a heat engine are given. The power output of the heat engine is to be determined.

Assumptions 1 The plant operates steadily. 2 Heat losses from the working fluid at the pipes and other components are negligible.

Analysis Applying the definition of the thermal efficiency to the heat engine,

$$\begin{aligned} \dot{W}_{\text{net}} &= \eta_{\text{th}} \dot{Q}_H \\ &= (0.4)(3 \times 10^4 \text{ Btu/h}) \left(\frac{1 \text{ hp}}{2544.5 \text{ Btu/h}} \right) \\ &= \mathbf{4.72 \text{ hp}} \end{aligned}$$

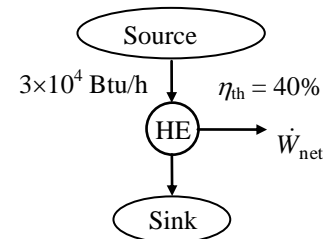

6-18 The power output and thermal efficiency of a heat engine are given. The rate of heat input is to be determined.

Assumptions 1 The plant operates steadily. 2 Heat losses from the working fluid at the pipes and other components are negligible.

Analysis Applying the definition of the thermal efficiency to the heat engine,

$$\dot{Q}_H = \frac{\dot{W}_{\text{net}}}{\eta_{\text{th}}} = \frac{60 \text{ hp}}{0.35} \left(\frac{0.7457 \text{ kJ/s}}{1 \text{ hp}} \right) = \mathbf{128 \text{ kJ/s}}$$

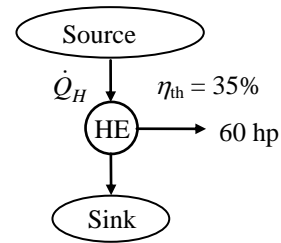

6-19 The power output and thermal efficiency of a power plant are given. The rate of heat rejection is to be determined, and the result is to be compared to the actual case in practice.

Assumptions 1 The plant operates steadily. 2 Heat losses from the working fluid at the pipes and other components are negligible.

Analysis The rate of heat supply to the power plant is determined from the thermal efficiency relation,

$$\dot{Q}_H = \frac{\dot{W}_{\text{net,out}}}{\eta_{\text{th}}} = \frac{600 \text{ MW}}{0.4} = 1500 \text{ MW}$$

The rate of heat transfer to the river water is determined from the first law relation for a heat engine,

$$\dot{Q}_L = \dot{Q}_H - \dot{W}_{\text{net,out}} = 1500 - 600 = \mathbf{900 \text{ MW}}$$

In reality the amount of heat rejected to the river will be **lower** since part of the heat will be lost to the surrounding air from the working fluid as it passes through the pipes and other components.

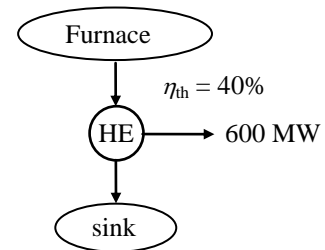

6-20 The work output and heat input of a heat engine are given. The heat rejection is to be determined.

Assumptions 1 The plant operates steadily. 2 Heat losses from the working fluid at the pipes and other components are negligible.

Analysis Applying the first law to the heat engine gives

$$Q_L = Q_H - W_{\text{net}} = 700 \text{ kJ} - 250 \text{ kJ} = \mathbf{450 \text{ kJ}}$$

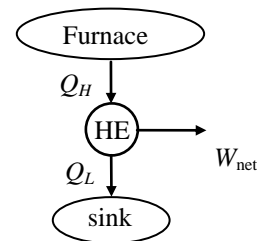

6-21 The heat rejection and thermal efficiency of a heat engine are given. The heat input to the engine is to be determined.

Assumptions 1 The plant operates steadily. 2 Heat losses from the working fluid at the pipes and other components are negligible.

Analysis According to the definition of the thermal efficiency as applied to the heat engine,

$$w_{\text{net}} = \eta_{\text{th}} q_H$$

$$q_H - q_L = \eta_{\text{th}} q_H$$

which when rearranged gives

$$q_H = \frac{q_L}{1 - \eta_{\text{th}}} = \frac{500 \text{ kJ/kg}}{1 - 0.45} = \mathbf{909 \text{ kJ/kg}}$$

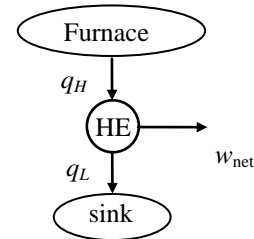

6-22 The power output and fuel consumption rate of a power plant are given. The thermal efficiency is to be determined.

Assumptions The plant operates steadily.

Properties The heating value of coal is given to be 30,000 kJ/kg.

Analysis The rate of heat supply to this power plant is

$$\begin{aligned} \dot{Q}_H &= \dot{m}_{\text{coal}} q_{\text{HV,coal}} \\ &= (60,000 \text{ kg/h})(30,000 \text{ kJ/kg}) = 1.8 \times 10^9 \text{ kJ/h} \\ &= 500 \text{ MW} \end{aligned}$$

Then the thermal efficiency of the plant becomes

$$\eta_{\text{th}} = \frac{\dot{W}_{\text{net,out}}}{\dot{Q}_H} = \frac{150 \text{ MW}}{500 \text{ MW}} = 0.300 = \mathbf{30.0\%}$$

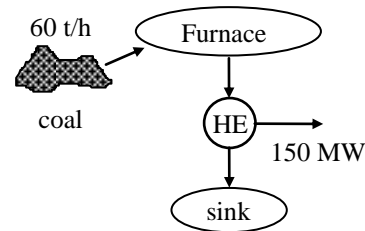

6-23 The power output and fuel consumption rate of a car engine are given. The thermal efficiency of the engine is to be determined.

Assumptions The car operates steadily.

Properties The heating value of the fuel is given to be 44,000 kJ/kg.

Analysis The mass consumption rate of the fuel is

$$\dot{m}_{\text{fuel}} = (\rho \dot{V})_{\text{fuel}} = (0.8 \text{ kg/L})(22 \text{ L/h}) = 17.6 \text{ kg/h}$$

The rate of heat supply to the car is

$$\begin{aligned} \dot{Q}_H &= \dot{m}_{\text{fuel}} q_{\text{HV,fuel}} \\ &= (17.6 \text{ kg/h})(44,000 \text{ kJ/kg}) \\ &= 774,400 \text{ kJ/h} = 215.1 \text{ kW} \end{aligned}$$

Then the thermal efficiency of the car becomes

$$\eta_{\text{th}} = \frac{\dot{W}_{\text{net,out}}}{\dot{Q}_H} = \frac{55 \text{ kW}}{215.1 \text{ kW}} = 0.256 = \mathbf{25.6\%}$$

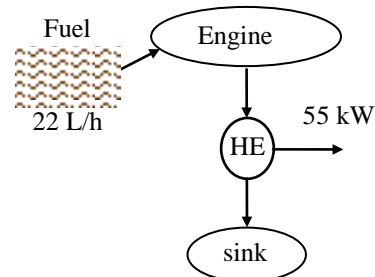

6-24 The United States produces about 51 percent of its electricity from coal at a conversion efficiency of about 34 percent. The amount of heat rejected by the coal-fired power plants per year is to be determined.

Analysis Noting that the conversion efficiency is 34%, the amount of heat rejected by the coal plants per year is

$$\begin{aligned}\eta_{th} &= \frac{W_{\text{coal}}}{Q_{\text{in}}} = \frac{W_{\text{coal}}}{Q_{\text{out}} + W_{\text{coal}}} \\ Q_{\text{out}} &= \frac{W_{\text{coal}}}{\eta_{th}} - W_{\text{coal}} \\ &= \frac{1.878 \times 10^{12} \text{ kWh}}{0.34} - 1.878 \times 10^{12} \text{ kWh} \\ &= \mathbf{3.646 \times 10^{12} \text{ kWh}}\end{aligned}$$

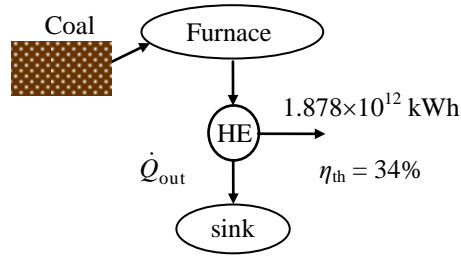

6-25E The power output and thermal efficiency of a solar pond power plant are given. The rate of solar energy collection is to be determined.

Assumptions The plant operates steadily.

Analysis The rate of solar energy collection or the rate of heat supply to the power plant is determined from the thermal efficiency relation to be

$$\dot{Q}_H = \frac{\dot{W}_{\text{net,out}}}{\eta_{th}} = \frac{180 \text{ kW}}{0.03} \left(\frac{1 \text{ Btu}}{1.055 \text{ kJ}} \right) \left(\frac{3600 \text{ s}}{1 \text{ h}} \right) = \mathbf{2.05 \times 10^7 \text{ Btu/h}}$$

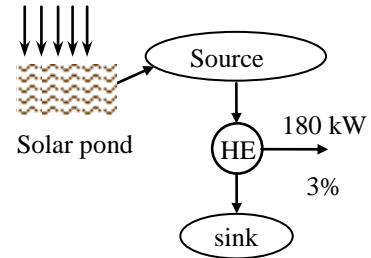

6-26 A coal-burning power plant produces 300 MW of power. The amount of coal consumed during a one-day period and the rate of air flowing through the furnace are to be determined.

Assumptions 1 The power plant operates steadily. 2 The kinetic and potential energy changes are zero.

Properties The heating value of the coal is given to be 28,000 kJ/kg.

Analysis (a) The rate and the amount of heat inputs to the power plant are

$$\begin{aligned}\dot{Q}_{\text{in}} &= \frac{\dot{W}_{\text{net,out}}}{\eta_{th}} = \frac{300 \text{ MW}}{0.32} = 937.5 \text{ MW} \\ Q_{\text{in}} &= \dot{Q}_{\text{in}} \Delta t = (937.5 \text{ MJ/s})(24 \times 3600 \text{ s}) = 8.1 \times 10^7 \text{ MJ}\end{aligned}$$

The amount and rate of coal consumed during this period are

$$\begin{aligned}m_{\text{coal}} &= \frac{Q_{\text{in}}}{q_{\text{HV}}} = \frac{8.1 \times 10^7 \text{ MJ}}{28 \text{ MJ/kg}} = \mathbf{2.893 \times 10^6 \text{ kg}} \\ \dot{m}_{\text{coal}} &= \frac{m_{\text{coal}}}{\Delta t} = \frac{2.893 \times 10^6 \text{ kg}}{24 \times 3600 \text{ s}} = 33.48 \text{ kg/s}\end{aligned}$$

(b) Noting that the air-fuel ratio is 12, the rate of air flowing through the furnace is

$$\dot{m}_{\text{air}} = (\text{AF})\dot{m}_{\text{coal}} = (12 \text{ kg air/kg fuel})(33.48 \text{ kg/s}) = \mathbf{401.8 \text{ kg/s}}$$

6-27E An OTEC power plant operates between the temperature limits of 86°F and 41°F. The cooling water experiences a temperature rise of 6°F in the condenser. The amount of power that can be generated by this OTEC plant is to be determined.

Assumptions 1 Steady operating conditions exist. 2 Water is an incompressible substance with constant properties.

Properties The density and specific heat of water are taken $\rho = 64.0$ lbm/ft³ and $c = 1.0$ Btu/lbm·°F, respectively.

Analysis The mass flow rate of the cooling water is

$$\dot{m}_{\text{water}} = \rho \dot{V}_{\text{water}} = (64.0 \text{ lbm/ft}^3)(13,300 \text{ gal/min}) \left(\frac{1 \text{ ft}^3}{7.4804 \text{ gal}} \right) = 113,790 \text{ lbm/min} = 1897 \text{ lbm/s}$$

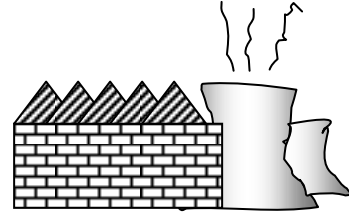

The rate of heat rejection to the cooling water is

$$\dot{Q}_{\text{out}} = \dot{m}_{\text{water}} c (T_{\text{out}} - T_{\text{in}}) = (1897 \text{ lbm/s})(1.0 \text{ Btu/lbm}\cdot\text{°F})(6\text{°F}) = 11,380 \text{ Btu/s}$$

Noting that the thermal efficiency of this plant is 2.5%, the power generation is determined to be

$$\eta = \frac{\dot{W}}{\dot{Q}_{\text{in}}} = \frac{\dot{W}}{\dot{W} + \dot{Q}_{\text{out}}} \rightarrow 0.025 = \frac{\dot{W}}{\dot{W} + (11,380 \text{ Btu/s})} \rightarrow \dot{W} = 292 \text{ Btu/s} = \mathbf{308 \text{ kW}}$$

since 1 kW = 0.9478 Btu/s.

Refrigerators and Heat Pumps

6-28C The difference between the two devices is one of purpose. The purpose of a refrigerator is to remove heat from a cold medium whereas the purpose of a heat pump is to supply heat to a warm medium.

6-29C The difference between the two devices is one of purpose. The purpose of a refrigerator is to remove heat from a refrigerated space whereas the purpose of an air-conditioner is to remove heat from a living space.

6-30C No. Because the refrigerator consumes work to accomplish this task.

6-31C No. Because the heat pump consumes work to accomplish this task.

6-32C The coefficient of performance of a refrigerator represents the amount of heat removed from the refrigerated space for each unit of work supplied. It can be greater than unity.

6-33C The coefficient of performance of a heat pump represents the amount of heat supplied to the heated space for each unit of work supplied. It can be greater than unity.

6-34C No. The heat pump captures energy from a cold medium and carries it to a warm medium. It does not create it.

6-35C No. The refrigerator captures energy from a cold medium and carries it to a warm medium. It does not create it.

6-36C No device can transfer heat from a cold medium to a warm medium without requiring a heat or work input from the surroundings.

6-37C The violation of one statement leads to the violation of the other one, as shown in Sec. 6-4, and thus we conclude that the two statements are equivalent.

6-38 The heat removal rate of a refrigerator per kW of power it consumes is given. The COP and the rate of heat rejection are to be determined.

Assumptions The refrigerator operates steadily.

Analysis The coefficient of performance of the refrigerator is determined from its definition,

$$\text{COP}_R = \frac{\dot{Q}_L}{\dot{W}_{\text{net,in}}} = \frac{5040 \text{ kJ/h}}{1 \text{ kW}} \left(\frac{1 \text{ kW}}{3600 \text{ kJ/h}} \right) = \mathbf{1.4}$$

The rate of heat rejection to the surrounding air, per kW of power consumed, is determined from the energy balance,

$$\dot{Q}_H = \dot{Q}_L + \dot{W}_{\text{net,in}} = (5040 \text{ kJ/h}) + (1 \times 3600 \text{ kJ/h}) = \mathbf{8640 \text{ kJ/h}}$$

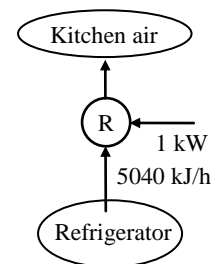

6-39 The rate of heat supply of a heat pump per kW of power it consumes is given. The COP and the rate of heat absorption from the cold environment are to be determined.

Assumptions The heat pump operates steadily.

Analysis The coefficient of performance of the refrigerator is determined from its definition,

$$\text{COP}_{\text{HP}} = \frac{\dot{Q}_H}{\dot{W}_{\text{net,in}}} = \frac{8000 \text{ kJ/h}}{1 \text{ kW}} \left(\frac{1 \text{ kW}}{3600 \text{ kJ/h}} \right) = \mathbf{2.22}$$

The rate of heat absorption from the surrounding air, per kW of power consumed, is determined from the energy balance,

$$\dot{Q}_L = \dot{Q}_H - \dot{W}_{\text{net,in}} = (8,000 \text{ kJ/h}) - (1)(3600 \text{ kJ/h}) = \mathbf{4400 \text{ kJ/h}}$$

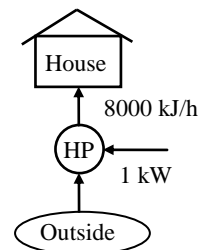

6-40E The COP and the power input of a residential heat pump are given. The rate of heating effect is to be determined.

Assumptions The heat pump operates steadily.

Analysis Applying the definition of the heat pump coefficient of performance to this heat pump gives

$$\dot{Q}_H = \text{COP}_{\text{HP}} \dot{W}_{\text{net,in}} = (2.4)(5 \text{ hp}) \left(\frac{2544.5 \text{ Btu/h}}{1 \text{ hp}} \right) = \mathbf{30,530 \text{ Btu/h}}$$

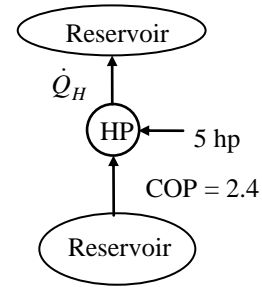

6-41 The power input and the COP of a refrigerator are given. The cooling effect of the refrigerator is to be determined.

Assumptions The refrigerator operates steadily.

Analysis Rearranging the definition of the refrigerator coefficient of performance and applying the result to this refrigerator gives

$$\dot{Q}_L = \text{COP}_R \dot{W}_{\text{net,in}} = (1.8)(1.2 \text{ kW}) = \mathbf{2.16 \text{ kW}}$$

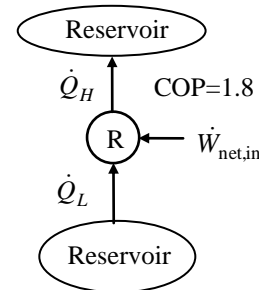

6-42 The power consumption and the cooling rate of an air conditioner are given. The COP and the rate of heat rejection are to be determined.

Assumptions The air conditioner operates steadily.

Analysis (a) The coefficient of performance of the air-conditioner (or refrigerator) is determined from its definition,

$$\text{COP}_R = \frac{\dot{Q}_L}{\dot{W}_{\text{net,in}}} = \frac{750 \text{ kJ/min}}{6 \text{ kW}} \left(\frac{1 \text{ kW}}{60 \text{ kJ/min}} \right) = \mathbf{2.08}$$

b) The rate of heat discharge to the outside air is determined from the energy balance,

$$\dot{Q}_H = \dot{Q}_L + \dot{W}_{\text{net,in}} = (750 \text{ kJ/min}) + (6 \times 60 \text{ kJ/min}) = \mathbf{1110 \text{ kJ/min}}$$

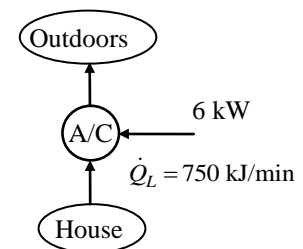

6-43 A refrigerator is used to keep a food department at a specified temperature. The heat gain to the food department and the heat rejection in the condenser are given. The power input and the COP are to be determined.

Assumptions The refrigerator operates steadily.

Analysis The power input is determined from

$$\begin{aligned}\dot{W}_{\text{in}} &= \dot{Q}_H - \dot{Q}_L \\ &= 4800 - 3300 = 1500 \text{ kJ/h} \\ &= (1500 \text{ kJ/h}) \left(\frac{1 \text{ kW}}{3600 \text{ kJ/h}} \right) = \mathbf{0.417 \text{ kW}}\end{aligned}$$

The COP is

$$\text{COP} = \frac{\dot{Q}_L}{\dot{W}_{\text{in}}} = \frac{3300 \text{ kJ/h}}{1500 \text{ kJ/h}} = \mathbf{2.2}$$

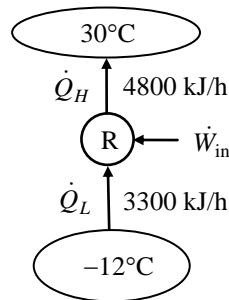

6-44 The COP and the power consumption of a refrigerator are given. The time it will take to cool 5 watermelons is to be determined.

Assumptions 1 The refrigerator operates steadily. 2 The heat gain of the refrigerator through its walls, door, etc. is negligible. 3 The watermelons are the only items in the refrigerator to be cooled.

Properties The specific heat of watermelons is given to be $c = 4.2 \text{ kJ/kg} \cdot ^\circ\text{C}$.

Analysis The total amount of heat that needs to be removed from the watermelons is

$$Q_L = (mc\Delta T)_{\text{watermelons}} = 5 \times (10 \text{ kg}) (4.2 \text{ kJ/kg} \cdot ^\circ\text{C}) (28 - 8)^\circ\text{C} = 4200 \text{ kJ}$$

The rate at which this refrigerator removes heat is

$$\dot{Q}_L = (\text{COP}_R)(\dot{W}_{\text{net,in}}) = (1.5)(0.45 \text{ kW}) = 0.675 \text{ kW}$$

That is, this refrigerator can remove 0.675 kJ of heat per second. Thus the time required to remove 4200 kJ of heat is

$$\Delta t = \frac{Q_L}{\dot{Q}_L} = \frac{4200 \text{ kJ}}{0.675 \text{ kJ/s}} = 6222 \text{ s} = \mathbf{104 \text{ min}}$$

This answer is optimistic since the refrigerated space will gain some heat during this process from the surrounding air, which will increase the work load. Thus, in reality, it will take longer to cool the watermelons.

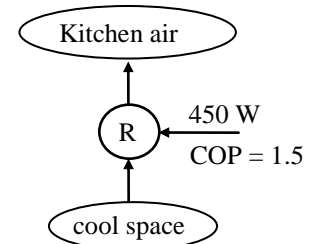

6-45  An air conditioner with a known COP cools a house to desired temperature in 15 min. The power consumption of the air conditioner is to be determined.

Assumptions **1** The air conditioner operates steadily. **2** The house is well-sealed so that no air leaks in or out during cooling. **3** Air is an ideal gas with constant specific heats at room temperature.

Properties The constant volume specific heat of air is given to be $c_v = 0.72 \text{ kJ/kg} \cdot ^\circ\text{C}$.

Analysis Since the house is well-sealed (constant volume), the total amount of heat that needs to be removed from the house is

$$Q_L = (mc_v \Delta T)_{\text{House}} = (800 \text{ kg})(0.72 \text{ kJ/kg} \cdot ^\circ\text{C})(35 - 20)^\circ\text{C} = 8640 \text{ kJ}$$

This heat is removed in 30 minutes. Thus the average rate of heat removal from the house is

$$\dot{Q}_L = \frac{Q_L}{\Delta t} = \frac{8640 \text{ kJ}}{30 \times 60 \text{ s}} = 4.8 \text{ kW}$$

Using the definition of the coefficient of performance, the power input to the air conditioner is determined to be

$$\dot{W}_{\text{net,in}} = \frac{\dot{Q}_L}{\text{COP}_R} = \frac{4.8 \text{ kW}}{2.8} = \mathbf{1.71 \text{ kW}}$$

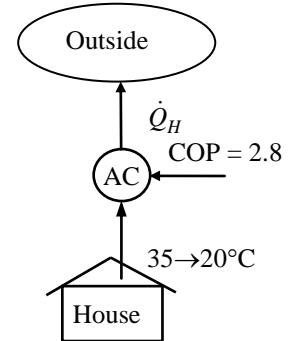



6-46 Problem 6-45 is reconsidered. The rate of power drawn by the air conditioner required to cool the house as a function for air conditioner EER ratings in the range 5 to 15 is to be investigated. Representative costs of air conditioning units in the EER rating range are to be included.

Analysis The problem is solved using EES, and the results are tabulated and plotted below.

"Since it is well sealed, we treat the house as a closed system (constant volume) to determine the rate of heat transfer required to cool the house. Apply the first law, closed system on a rate basis to the house."

"Input Data"

T_1=35 [C]
 T_2=20 [C]
 c_v = 0.72 [kJ/kg-C]
 m_house=800 [kg]
 DELTAtime=30 [min]
 "EER=5"
 COP=EER/3.412

"Assuming no work done on the house and no heat energy added to the house in the time period with no change in KE and PE, the first law applied to the house is:"

E_dot_in - E_dot_out = DELTAE_dot
 E_dot_in = 0
 E_dot_out = Q_dot_L
 DELTAE_dot = m_house*DELTAu_house/DELTAtime
 DELTAu_house = c_v*(T_2-T_1)

"Using the definition of the coefficient of performance of the A/C:"

W_dot_in = Q_dot_L/COP "kJ/min"*convert('kJ/min','kW') "kW"
 Q_dot_H= W_dot_in*convert('kW','kJ/min') + Q_dot_L "kJ/min"

EER	\dot{W}_{in} [kW]
5	3.276
6	2.73
7	2.34
8	2.047
9	1.82
10	1.638
11	1.489
12	1.365
13	1.26
14	1.17
15	1.092

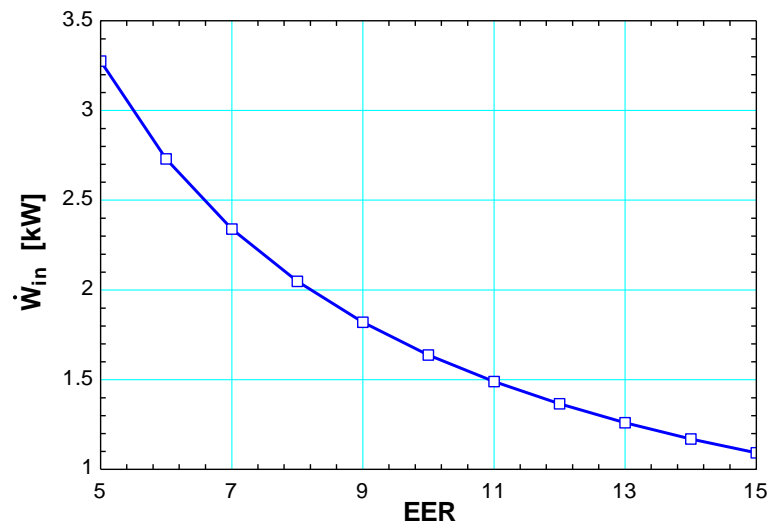

6-47E The rate of heat supply and the COP of a heat pump are given. The power consumption and the rate of heat absorption from the outside air are to be determined.

Assumptions The heat pump operates steadily.

Analysis (a) The power consumed by this heat pump can be determined from the definition of the coefficient of performance of a heat pump to be

$$\dot{W}_{\text{net,in}} = \frac{\dot{Q}_H}{\text{COP}_{\text{HP}}} = \frac{60,000 \text{ Btu/h}}{2.5} = 24,000 \text{ Btu/h} = \mathbf{9.43 \text{ hp}}$$

(b) The rate of heat transfer from the outdoor air is determined from the conservation of energy principle,

$$\dot{Q}_L = \dot{Q}_H - \dot{W}_{\text{net,in}} = (60,000 - 24,000) \text{ Btu/h} = \mathbf{36,000 \text{ Btu/h}}$$

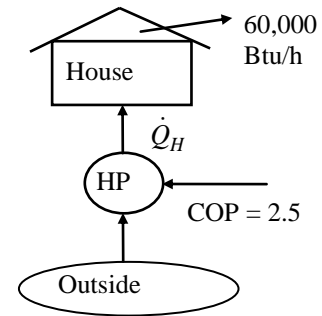

6-48 A refrigerator is used to cool bananas to a specified temperature. The power input is given. The rate of cooling and the COP are to be determined.

Assumptions The refrigerator operates steadily.

Properties The specific heat of banana is $3.35 \text{ kJ/kg}\cdot^\circ\text{C}$.

Analysis The rate of cooling is determined from

$$\dot{Q}_L = \dot{m}c_p(T_1 - T_2) = (215/60 \text{ kg/min})(3.35 \text{ kJ/kg}\cdot^\circ\text{C})(24 - 13)^\circ\text{C} = \mathbf{132 \text{ kJ/min}}$$

The COP is

$$\text{COP} = \frac{\dot{Q}_L}{\dot{W}_{\text{in}}} = \frac{(132/60) \text{ kW}}{1.4 \text{ kW}} = \mathbf{1.57}$$

6-49 The rate of heat loss, the rate of internal heat gain, and the COP of a heat pump are given. The power input to the heat pump is to be determined.

Assumptions The heat pump operates steadily.

Analysis The heating load of this heat pump system is the difference between the heat lost to the outdoors and the heat generated in the house from the people, lights, and appliances,

$$\dot{Q}_H = 85,000 - 4000 = 81,000 \text{ kJ/h}$$

Using the definition of COP, the power input to the heat pump is determined to be

$$\dot{W}_{\text{net,in}} = \frac{\dot{Q}_H}{\text{COP}_{\text{HP}}} = \frac{81,000 \text{ kJ/h}}{3.2} \left(\frac{1 \text{ kW}}{3600 \text{ kJ/h}} \right) = \mathbf{7.03 \text{ kW}}$$

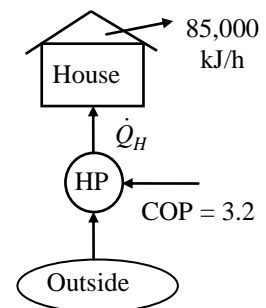

6-50E The COP and the refrigeration rate of an ice machine are given. The power consumption is to be determined.

Assumptions The ice machine operates steadily.

Analysis The cooling load of this ice machine is

$$\dot{Q}_L = \dot{m}q_L = (28 \text{ lbm/h})(169 \text{ Btu/lbm}) = 4732 \text{ Btu/h}$$

Using the definition of the coefficient of performance, the power input to the ice machine system is determined to be

$$\dot{W}_{\text{net,in}} = \frac{\dot{Q}_L}{\text{COP}_R} = \frac{4732 \text{ Btu/h}}{2.4} \left(\frac{1 \text{ hp}}{2545 \text{ Btu/h}} \right) = \mathbf{0.775 \text{ hp}}$$

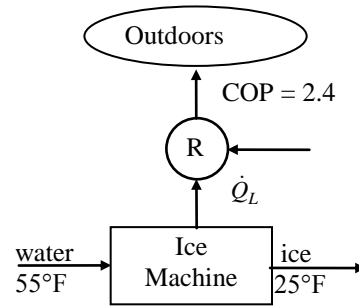

6-51 The COP and the refrigeration rate of a refrigerator are given. The power consumption of the refrigerator is to be determined.

Assumptions The refrigerator operates steadily.

Analysis Since the refrigerator runs one-fourth of the time and removes heat from the food compartment at an average rate of 800 kJ/h, the refrigerator removes heat at a rate of

$$\dot{Q}_L = 4 \times (800 \text{ kJ/h}) = 3200 \text{ kJ/h}$$

when running. Thus the power the refrigerator draws when it is running is

$$\dot{W}_{\text{net,in}} = \frac{\dot{Q}_L}{\text{COP}_R} = \frac{3200 \text{ kJ/h}}{2.2} = 1455 \text{ kJ/h} = \mathbf{0.40 \text{ kW}}$$

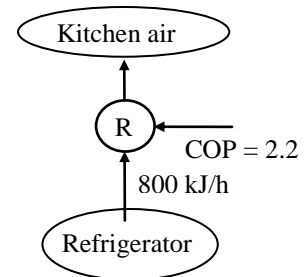

6-52 The rate of heat loss from a house and the COP of the heat pump are given. The power consumption of the heat pump when it is running is to be determined.

Assumptions The heat pump operates one-third of the time.

Analysis Since the heat pump runs one-third of the time and must supply heat to the house at an average rate of 22,000 kJ/h, the heat pump supplies heat at a rate of

$$\dot{Q}_H = 3 \times (22,000 \text{ kJ/h}) = 66,000 \text{ kJ/h}$$

when running. Thus the power the heat pump draws when it is running is

$$\dot{W}_{\text{net,in}} = \frac{\dot{Q}_H}{\text{COP}_{\text{HP}}} = \frac{66,000 \text{ kJ/h}}{2.8} \left(\frac{1 \text{ kW}}{3600 \text{ kJ/h}} \right) = \mathbf{6.55 \text{ kW}}$$

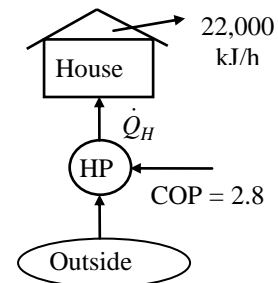

6-53E An office that is being cooled adequately by a 12,000 Btu/h window air-conditioner is converted to a computer room. The number of additional air-conditioners that need to be installed is to be determined.

Assumptions 1 The computers are operated by 7 adult men. **2** The computers consume 40 percent of their rated power at any given time.

Properties The average rate of heat generation from a person seated in a room/office is 100 W (given).

Analysis The amount of heat dissipated by the computers is equal to the amount of electrical energy they consume. Therefore,

$$\dot{Q}_{\text{computers}} = (\text{Rated power}) \times (\text{Usage factor}) = (8.4 \text{ kW})(0.4) = 3.36 \text{ kW}$$

$$\dot{Q}_{\text{people}} = (\text{No. of people}) \times \dot{Q}_{\text{person}} = 7 \times (100 \text{ W}) = 700 \text{ W}$$

$$\dot{Q}_{\text{total}} = \dot{Q}_{\text{computers}} + \dot{Q}_{\text{people}} = 3360 + 700 = 4060 \text{ W} = 13,853 \text{ Btu/h}$$

since $1 \text{ W} = 3.412 \text{ Btu/h}$. Then noting that each available air conditioner provides 7000 Btu/h cooling, the number of air-conditioners needed becomes

$$\begin{aligned} \text{No. of air conditioners} &= \frac{\text{Cooling load}}{\text{Cooling capacity of A/C}} = \frac{13,853 \text{ Btu/h}}{7000 \text{ Btu/h}} \\ &= 1.98 \approx \mathbf{2 \text{ Air conditioners}} \end{aligned}$$

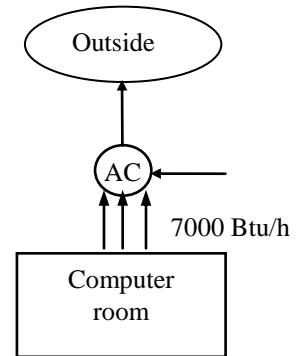

6-54 A decision is to be made between a cheaper but inefficient air-conditioner and an expensive but efficient air-conditioner for a building. The better buy is to be determined.

Assumptions The two air conditioners are comparable in all aspects other than the initial cost and the efficiency.

Analysis The unit that will cost less during its lifetime is a better buy. The total cost of a system during its lifetime (the initial, operation, maintenance, etc.) can be determined by performing a life cycle cost analysis. A simpler alternative is to determine the simple payback period. The energy and cost savings of the more efficient air conditioner in this case is

$$\begin{aligned} \text{Energy savings} &= (\text{Annual energy usage of A}) - (\text{Annual energy usage of B}) \\ &= (\text{Annual cooling load})(1/\text{COP}_A - 1/\text{COP}_B) \\ &= (40,000 \text{ kWh/year})(1/2.3 - 1/3.6) \\ &= 6280 \text{ kWh/year} \end{aligned}$$

$$\begin{aligned} \text{Cost savings} &= (\text{Energy savings})(\text{Unit cost of energy}) \\ &= (6280 \text{ kWh/year})(\$0.10/\text{kWh}) = \mathbf{\$628/\text{year}} \end{aligned}$$

The installation cost difference between the two air-conditioners is

$$\text{Cost difference} = \text{Cost of B} - \text{cost of A} = 7000 - 5500 = \$1500$$

Therefore, the more efficient air-conditioner B will pay for the \$1500 cost differential in this case in about $\$1500/\$628 = 2.39$ years.

Discussion A cost conscious consumer will have no difficulty in deciding that the more expensive but more efficient air-conditioner B is clearly the better buy in this case since air conditioners last at least 15 years. But the decision would not be so easy if the unit cost of electricity at that location was much less than \$0.10/kWh, or if the annual air-conditioning load of the house was much less than 40,000 kWh.

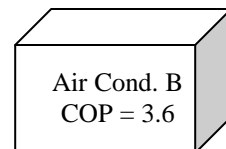
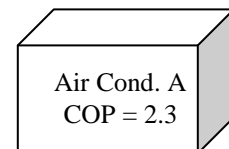

6-55 Refrigerant-134a flows through the condenser of a residential heat pump unit. For a given compressor power consumption the COP of the heat pump and the rate of heat absorbed from the outside air are to be determined.

Assumptions 1 The heat pump operates steadily. **2** The kinetic and potential energy changes are zero.

Properties The enthalpies of R-134a at the condenser inlet and exit are

$$\left. \begin{array}{l} P_1 = 800 \text{ kPa} \\ T_1 = 35^\circ\text{C} \end{array} \right\} h_1 = 271.24 \text{ kJ/kg}$$

$$\left. \begin{array}{l} P_2 = 800 \text{ kPa} \\ x_2 = 0 \end{array} \right\} h_2 = 95.48 \text{ kJ/kg}$$

Analysis (a) An energy balance on the condenser gives the heat rejected in the condenser

$$\dot{Q}_H = \dot{m}(h_1 - h_2) = (0.018 \text{ kg/s})(271.24 - 95.48) \text{ kJ/kg} = 3.164 \text{ kW}$$

The COP of the heat pump is

$$\text{COP} = \frac{\dot{Q}_H}{\dot{W}_{\text{in}}} = \frac{3.164 \text{ kW}}{1.2 \text{ kW}} = \mathbf{2.64}$$

(b) The rate of heat absorbed from the outside air

$$\dot{Q}_L = \dot{Q}_H - \dot{W}_{\text{in}} = 3.164 - 1.2 = \mathbf{1.96 \text{ kW}}$$

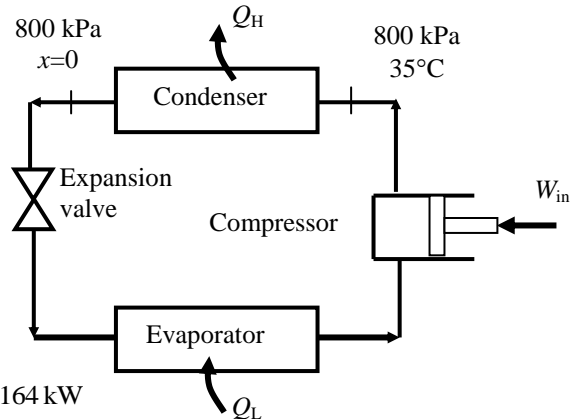

Perpetual-Motion Machines

6-56C This device creates energy, and thus it is a PMM1.

6-57C This device creates energy, and thus it is a PMM1.

Reversible and Irreversible Processes

6-58C No. Because it involves heat transfer through a finite temperature difference.

6-59C This process is irreversible. As the block slides down the plane, two things happen, (a) the potential energy of the block decreases, and (b) the block and plane warm up because of the friction between them. The potential energy that has been released can be stored in some form in the surroundings (e.g., perhaps in a spring). When we restore the system to its original condition, we must (a) restore the potential energy by lifting the block back to its original elevation, and (b) cool the block and plane back to their original temperatures.

The potential energy may be restored by returning the energy that was stored during the original process as the block decreased its elevation and released potential energy. The portion of the surroundings in which this energy had been stored would then return to its original condition as the elevation of the block is restored to its original condition.

In order to cool the block and plane to their original temperatures, we have to remove heat from the block and plane. When this heat is transferred to the surroundings, something in the surroundings has to change its state (e.g., perhaps we warm up some water in the surroundings). This change in the surroundings is permanent and cannot be undone. Hence, the original process is irreversible.

6-60C The chemical reactions of combustion processes of a natural gas and air mixture will generate carbon dioxide, water, and other compounds and will release heat energy to a lower temperature surroundings. It is unlikely that the surroundings will return this energy to the reacting system and the products of combustion react spontaneously to reproduce the natural gas and air mixture.

6-61C Adiabatic stirring processes are irreversible because the energy stored within the system can not be spontaneously released in a manner to cause the mass of the system to turn the **paddle wheel** in the opposite direction to do work on the surroundings.

6-62C When the compression process is non-quasi equilibrium, the molecules before the piston face cannot escape fast enough, forming a high pressure region in front of the piston. It takes more work to move the piston against this high pressure region.

6-63C When an expansion process is non-quasiequilibrium, the molecules before the piston face cannot follow the piston fast enough, forming a low pressure region behind the piston. The lower pressure that pushes the piston produces less work.

6-64C The irreversibilities that occur within the system boundaries are **internal** irreversibilities; those which occur outside the system boundaries are **external** irreversibilities.

6-65C A reversible expansion or compression process cannot involve unrestrained expansion or sudden compression, and thus it is quasi-equilibrium. A quasi-equilibrium expansion or compression process, on the other hand, may involve external irreversibilities (such as heat transfer through a finite temperature difference), and thus is not necessarily reversible.

6-66C Because reversible processes can be approached in reality, and they form the limiting cases. Work producing devices that operate on reversible processes deliver the most work, and work consuming devices that operate on reversible processes consume the least work.

The Carnot Cycle and Carnot's Principle

6-67C The four processes that make up the Carnot cycle are isothermal expansion, reversible adiabatic expansion, isothermal compression, and reversible adiabatic compression.

6-68C They are (1) the thermal efficiency of an irreversible heat engine is lower than the efficiency of a reversible heat engine operating between the same two reservoirs, and (2) the thermal efficiency of all the reversible heat engines operating between the same two reservoirs are equal.

6-69C (a) No, (b) No. They would violate the Carnot principle.

6-70C False. The second Carnot principle states that no heat engine cycle can have a higher thermal efficiency than the Carnot cycle operating between the same temperature limits.

6-71C Yes. The second Carnot principle states that all reversible heat engine cycles operating between the same temperature limits have the same thermal efficiency.

Carnot Heat Engines

6-72C No.

6-73C The one that has a source temperature of 600°C. This is true because the higher the temperature at which heat is supplied to the working fluid of a heat engine, the higher the thermal efficiency.

6-74 Two pairs of thermal energy reservoirs are to be compared from a work-production perspective.

Assumptions The heat engine operates steadily.

Analysis For the maximum production of work, a heat engine operating between the energy reservoirs would have to be completely reversible. Then, for the first pair of reservoirs

$$\eta_{\text{th,max}} = 1 - \frac{T_L}{T_H} = 1 - \frac{325 \text{ K}}{675 \text{ K}} = \mathbf{0.519}$$

For the second pair of reservoirs,

$$\eta_{\text{th,max}} = 1 - \frac{T_L}{T_H} = 1 - \frac{275 \text{ K}}{625 \text{ K}} = \mathbf{0.560}$$

The second pair is then capable of producing more work for each unit of heat extracted from the hot reservoir.

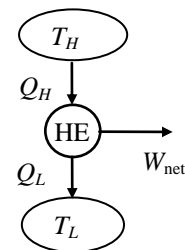

6-75E The sink temperature of a Carnot heat engine, the rate of heat rejection, and the thermal efficiency are given. The power output of the engine and the source temperature are to be determined.

Assumptions The Carnot heat engine operates steadily.

Analysis (a) The rate of heat input to this heat engine is determined from the definition of thermal efficiency,

$$\eta_{\text{th}} = 1 - \frac{\dot{Q}_L}{\dot{Q}_H} \longrightarrow 0.55 = 1 - \frac{800 \text{ Btu/min}}{\dot{Q}_H} \longrightarrow \dot{Q}_H = 1777.8 \text{ Btu/min}$$

Then the power output of this heat engine can be determined from

$$\dot{W}_{\text{net,out}} = \eta_{\text{th}} \dot{Q}_H = (0.55)(1777.8 \text{ Btu/min}) = 977.8 \text{ Btu/min} = \mathbf{23.1 \text{ hp}}$$

(b) For reversible cyclic devices we have $\left(\frac{\dot{Q}_H}{\dot{Q}_L}\right)_{\text{rev}} = \left(\frac{T_H}{T_L}\right)$

Thus the temperature of the source T_H must be

$$T_H = \left(\frac{\dot{Q}_H}{\dot{Q}_L}\right)_{\text{rev}} T_L = \left(\frac{1777.8 \text{ Btu/min}}{800 \text{ Btu/min}}\right)(520 \text{ R}) = \mathbf{1155.6 \text{ R}}$$

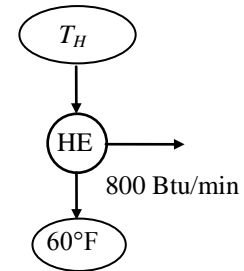

6-76 The sink temperature of a Carnot heat engine and the rates of heat supply and heat rejection are given. The source temperature and the thermal efficiency of the engine are to be determined.

Assumptions The Carnot heat engine operates steadily.

Analysis (a) For reversible cyclic devices we have $\left(\frac{Q_H}{Q_L}\right)_{\text{rev}} = \left(\frac{T_H}{T_L}\right)$

Thus the temperature of the source T_H must be

$$T_H = \left(\frac{Q_H}{Q_L}\right)_{\text{rev}} T_L = \left(\frac{650 \text{ kJ}}{250 \text{ kJ}}\right)(297 \text{ K}) = \mathbf{772.2 \text{ K}}$$

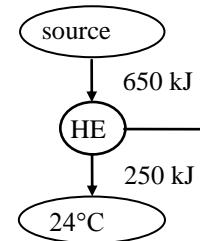

(b) The thermal efficiency of a Carnot heat engine depends on the source and the sink temperatures only, and is determined from

$$\eta_{\text{th,C}} = 1 - \frac{T_L}{T_H} = 1 - \frac{297 \text{ K}}{772.2 \text{ K}} = 0.615 \text{ or } \mathbf{61.5\%}$$

6-77 The source and sink temperatures of a Carnot heat engine and the rate of heat supply are given. The thermal efficiency and the power output are to be determined.

Assumptions The Carnot heat engine operates steadily.

Analysis (a) The thermal efficiency of a Carnot heat engine depends on the source and the sink temperatures only, and is determined from

$$\eta_{\text{th,C}} = 1 - \frac{T_L}{T_H} = 1 - \frac{300 \text{ K}}{1000 \text{ K}} = 0.70 \text{ or } \mathbf{70\%}$$

(b) The power output of this heat engine is determined from the definition of thermal efficiency,

$$\dot{W}_{\text{net,out}} = \eta_{\text{th}} \dot{Q}_H = (0.70)(800 \text{ kJ/min}) = 560 \text{ kJ/min} = \mathbf{9.33 \text{ kW}}$$

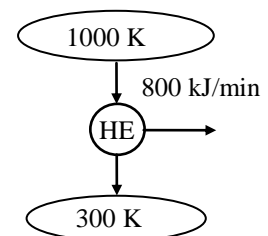

6-78  The source and sink temperatures of a heat engine and the rate of heat supply are given. The maximum possible power output of this engine is to be determined.

Assumptions The heat engine operates steadily.

Analysis The highest thermal efficiency a heat engine operating between two specified temperature limits can have is the Carnot efficiency, which is determined from

$$\eta_{\text{th,max}} = \eta_{\text{th,C}} = 1 - \frac{T_L}{T_H} = 1 - \frac{298 \text{ K}}{(477 + 273) \text{ K}} = 0.600 \text{ or } 60.0\%$$

Then the maximum power output of this heat engine is determined from the definition of thermal efficiency to be

$$\dot{W}_{\text{net,out}} = \eta_{\text{th}} \dot{Q}_H = (0.600)(65,000 \text{ kJ/min}) = 39,000 \text{ kJ/min} = \mathbf{653 \text{ kW}}$$

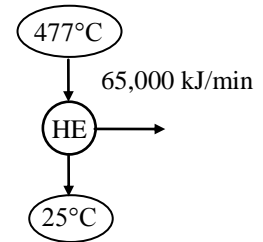



6-79 Problem 6-78 is reconsidered. The effects of the temperatures of the heat source and the heat sink on the power produced and the cycle thermal efficiency as the source temperature varies from 300°C to 1000°C and the sink temperature varies from 0°C to 50°C are to be studied. The power produced and the cycle efficiency against the source temperature for sink temperatures of 0°C, 25°C, and 50°C are to be plotted.

Analysis The problem is solved using EES, and the results are tabulated and plotted below.

$$T_H = 477 \text{ [C]}$$

$$T_L = 25 \text{ [C]}$$

$$Q_{\text{dot}_H} = 65000 \text{ [kJ/min]}$$

"First Law applied to the heat engine"

$$Q_{\text{dot}_H} - Q_{\text{dot}_L} - W_{\text{dot}_{\text{net}}} = 0$$

$$W_{\text{dot}_{\text{net_KW}}} = W_{\text{dot}_{\text{net}}} \cdot \text{convert}(\text{kJ/min}, \text{kW})$$

"Cycle Thermal Efficiency - Temperatures must be absolute"

$$\eta_{\text{th}} = 1 - (T_L + 273) / (T_H + 273)$$

"Definition of cycle efficiency"

$$\eta_{\text{th}} = W_{\text{dot}_{\text{net}}} / Q_{\text{dot}_H}$$

T_H [C]	W_{netKW} [kW]	η_{th}
300	567.2	0.5236
400	643.9	0.5944
500	700.7	0.6468
600	744.6	0.6873
700	779.4	0.7194
800	807.7	0.7456
900	831.2	0.7673
1000	851	0.7855

Values for $T_L = 0^\circ\text{C}$

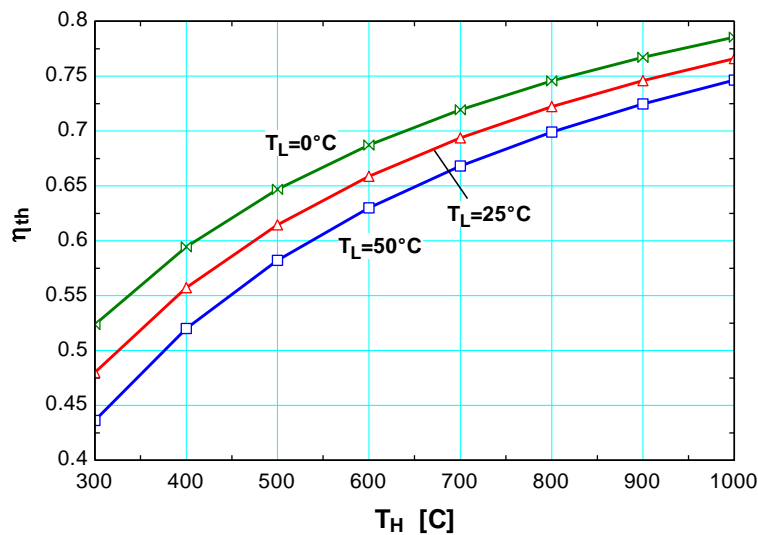
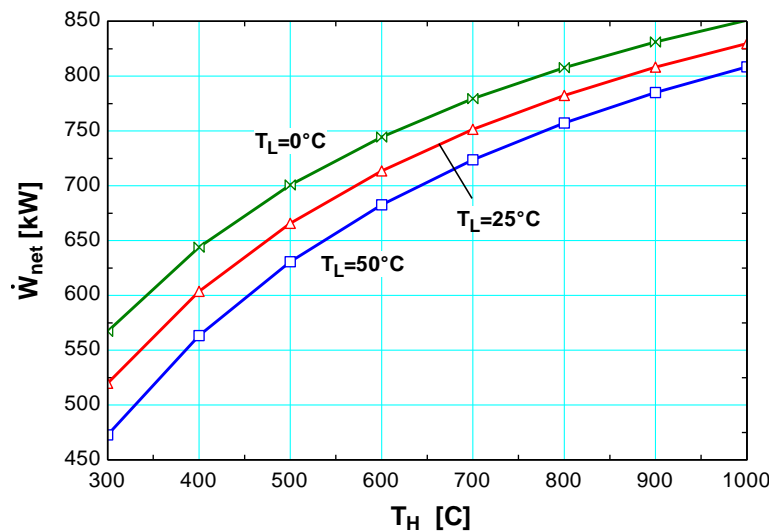

6-80E The claim of an inventor about the operation of a heat engine is to be evaluated.

Assumptions The heat engine operates steadily.

Analysis If this engine were completely reversible, the thermal efficiency would be

$$\eta_{\text{th,max}} = 1 - \frac{T_L}{T_H} = 1 - \frac{490 \text{ R}}{920 \text{ R}} = 0.467$$

When the first law is applied to the engine above,

$$\dot{Q}_H = \dot{W}_{\text{net}} + \dot{Q}_L = (4.5 \text{ hp}) \left(\frac{2544.5 \text{ Btu/h}}{1 \text{ hp}} \right) + 15,000 \text{ Btu/h} = 26,450 \text{ Btu/h}$$

The actual thermal efficiency of the proposed heat engine is then

$$\eta_{\text{th}} = \frac{\dot{W}_{\text{net}}}{\dot{Q}_H} = \frac{4.5 \text{ hp}}{26,450 \text{ Btu/h}} \left(\frac{2544.5 \text{ Btu/h}}{1 \text{ hp}} \right) = 0.433$$

Since the thermal efficiency of the proposed heat engine is smaller than that of a completely reversible heat engine which uses the same isothermal energy reservoirs, **the inventor's claim is valid** (but not probable with these values).

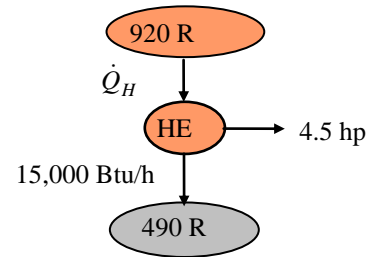

6-81 The work output and thermal efficiency of a Carnot heat engine are given. The heat supplied to the heat engine, the heat rejected and the temperature of heat sink are to be determined.

Assumptions 1 The heat engine operates steadily. 2 Heat losses from the working fluid at the pipes and other components are negligible.

Analysis Applying the definition of the thermal efficiency and an energy balance to the heat engine, the unknown values are determined as follows:

$$Q_H = \frac{W_{\text{net}}}{\eta_{\text{th}}} = \frac{500 \text{ kJ}}{0.4} = \mathbf{1250 \text{ kJ}}$$

$$Q_L = Q_H - W_{\text{net}} = 1250 - 500 = \mathbf{750 \text{ kJ}}$$

$$\eta_{\text{th,max}} = 1 - \frac{T_L}{T_H} \rightarrow 0.40 = 1 - \frac{T_L}{(1200 + 273) \text{ K}} \rightarrow T_L = 883.8 \text{ K} = \mathbf{611^\circ\text{C}}$$

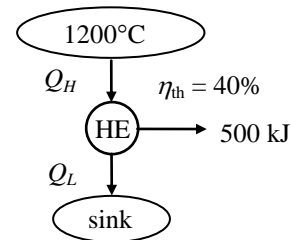

6-82 The source and sink temperatures of an OTEC (Ocean Thermal Energy Conversion) power plant are given. The maximum thermal efficiency is to be determined.

Assumptions The power plant operates steadily.

Analysis The highest thermal efficiency a heat engine operating between two specified temperature limits can have is the Carnot efficiency, which is determined from

$$\eta_{\text{th,max}} = \eta_{\text{th,C}} = 1 - \frac{T_L}{T_H} = 1 - \frac{276 \text{ K}}{297 \text{ K}} = 0.071 \text{ or } \mathbf{7.1\%}$$

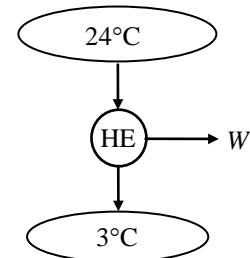

6-83 The source and sink temperatures of a geothermal power plant are given. The maximum thermal efficiency is to be determined.

Assumptions The power plant operates steadily.

Analysis The highest thermal efficiency a heat engine operating between two specified temperature limits can have is the Carnot efficiency, which is determined from

$$\eta_{\text{th,max}} = \eta_{\text{th,C}} = 1 - \frac{T_L}{T_H} = 1 - \frac{20 + 273 \text{ K}}{140 + 273 \text{ K}} = 0.291 \text{ or } \mathbf{29.1\%}$$

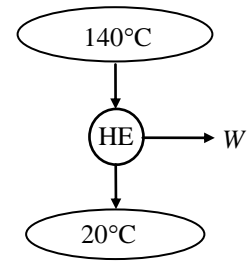

Carnot Refrigerators and Heat Pumps

6-84C The difference between the temperature limits is typically much higher for a refrigerator than it is for an air conditioner. The smaller the difference between the temperature limits a refrigerator operates on, the higher is the COP. Therefore, an air-conditioner should have a higher COP.

6-85C The deep freezer should have a lower COP since it operates at a much lower temperature, and in a given environment, the COP decreases with decreasing refrigeration temperature.

6-86C By increasing T_L or by decreasing T_H .

6-87C No. At best (when everything is reversible), the increase in the work produced will be equal to the work consumed by the refrigerator. In reality, the work consumed by the refrigerator will always be greater than the additional work produced, resulting in a decrease in the thermal efficiency of the power plant.

6-88C No. At best (when everything is reversible), the increase in the work produced will be equal to the work consumed by the refrigerator. In reality, the work consumed by the refrigerator will always be greater than the additional work produced, resulting in a decrease in the thermal efficiency of the power plant.

6-89C Bad idea. At best (when everything is reversible), the increase in the work produced will be equal to the work consumed by the heat pump. In reality, the work consumed by the heat pump will always be greater than the additional work produced, resulting in a decrease in the thermal efficiency of the power plant.

6-90 An experimentalist claims to have developed a refrigerator. The experimentalist reports temperature, heat transfer, and work input measurements. The claim is to be evaluated.

Analysis The highest coefficient of performance a refrigerator can have when removing heat from a cool medium at -30°C to a warmer medium at 25°C is

$$\text{COP}_{R,\max} = \text{COP}_{R,\text{rev}} = \frac{1}{(T_H/T_L)-1} = \frac{1}{(25+273\text{ K})/(-30+273\text{ K})-1} = 4.42$$

The work consumed by the actual refrigerator during this experiment is

$$W_{\text{net,in}} = \dot{W}_{\text{net,in}} \Delta t = (2\text{ kJ/s})(20 \times 60\text{ s}) = 2400\text{ kJ}$$

Then the coefficient of performance of this refrigerator becomes

$$\text{COP}_R = \frac{Q_L}{W_{\text{net,in}}} = \frac{30,000\text{ kJ}}{2400\text{ kJ}} = 12.5$$

which is above the maximum value. Therefore, these measurements are **not reasonable**.

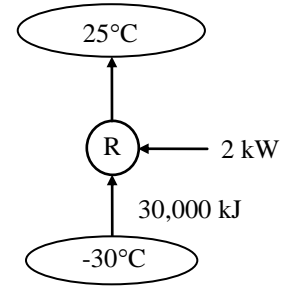

6-91 The refrigerated space and the environment temperatures of a Carnot refrigerator and the power consumption are given. The rate of heat removal from the refrigerated space is to be determined.

Assumptions The Carnot refrigerator operates steadily.

Analysis The coefficient of performance of a Carnot refrigerator depends on the temperature limits in the cycle only, and is determined from

$$\text{COP}_{R,C} = \frac{1}{(T_H/T_L)-1} = \frac{1}{(22+273\text{ K})/(3+273\text{ K})-1} = 14.5$$

The rate of heat removal from the refrigerated space is determined from the definition of the coefficient of performance of a refrigerator,

$$\dot{Q}_L = \text{COP}_R \dot{W}_{\text{net,in}} = (14.5)(2\text{ kW}) = 29.0\text{ kW} = \mathbf{1740\text{ kJ/min}}$$

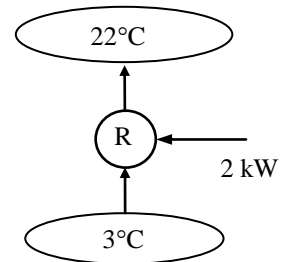

6-92 The cooled space and the outdoors temperatures for a Carnot air-conditioner and the rate of heat removal from the air-conditioned room are given. The power input required is to be determined.

Assumptions The air-conditioner operates steadily.

Analysis The COP of a Carnot air conditioner (or Carnot refrigerator) depends on the temperature limits in the cycle only, and is determined from

$$\text{COP}_{R,C} = \frac{1}{(T_H/T_L)-1} = \frac{1}{(35+273\text{ K})/(24+273\text{ K})-1} = 27.0$$

The power input to this refrigerator is determined from the definition of the coefficient of performance of a refrigerator,

$$\dot{W}_{\text{net,in}} = \frac{\dot{Q}_L}{\text{COP}_{R,\max}} = \frac{750\text{ kJ/min}}{27.0} = 27.8\text{ kJ/min} = \mathbf{0.463\text{ kW}}$$

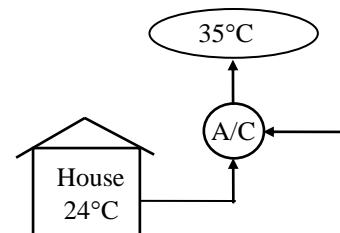

6-93 The validity of a claim by an inventor related to the operation of a heat pump is to be evaluated.

Assumptions The heat pump operates steadily.

Analysis Applying the definition of the heat pump coefficient of performance,

$$\text{COP}_{\text{HP}} = \frac{\dot{Q}_H}{\dot{W}_{\text{net,in}}} = \frac{200 \text{ kW}}{75 \text{ kW}} = 2.67$$

The maximum COP of a heat pump operating between the same temperature limits is

$$\text{COP}_{\text{HP,max}} = \frac{1}{1 - T_L / T_H} = \frac{1}{1 - (273 \text{ K}) / (293 \text{ K})} = 14.7$$

Since the actual COP is less than the maximum COP, the claim is **valid**.

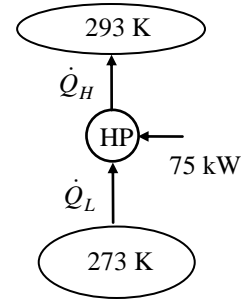

6-94 The power input and the COP of a Carnot heat pump are given. The temperature of the low-temperature reservoir and the heating load are to be determined.

Assumptions The heat pump operates steadily.

Analysis The temperature of the low-temperature reservoir is

$$\text{COP}_{\text{HP,max}} = \frac{T_H}{T_H - T_L} \longrightarrow 8.7 = \frac{297 \text{ K}}{(297 - T_L) \text{ K}} \longrightarrow T_L = \mathbf{263 \text{ K}}$$

The heating load is

$$\text{COP}_{\text{HP,max}} = \frac{\dot{Q}_H}{\dot{W}_{\text{in}}} \longrightarrow 8.7 = \frac{\dot{Q}_H}{2.15 \text{ kW}} \longrightarrow \dot{Q}_H = \mathbf{18.7 \text{ kW}}$$

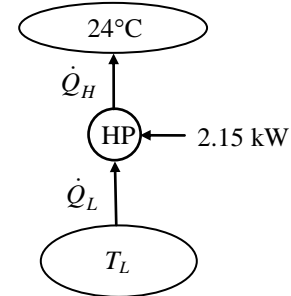

6-95 The refrigerated space and the environment temperatures for a refrigerator and the rate of heat removal from the refrigerated space are given. The minimum power input required is to be determined.

Assumptions The refrigerator operates steadily.

Analysis The power input to a refrigerator will be a minimum when the refrigerator operates in a reversible manner. The coefficient of performance of a reversible refrigerator depends on the temperature limits in the cycle only, and is determined from

$$\text{COP}_{\text{R,rev}} = \frac{1}{(T_H / T_L) - 1} = \frac{1}{(25 + 273 \text{ K}) / (-8 + 273 \text{ K}) - 1} = 8.03$$

The power input to this refrigerator is determined from the definition of the coefficient of performance of a refrigerator,

$$\dot{W}_{\text{net,in,min}} = \frac{\dot{Q}_L}{\text{COP}_{\text{R,max}}} = \frac{300 \text{ kJ/min}}{8.03} = 37.36 \text{ kJ/min} = \mathbf{0.623 \text{ kW}}$$

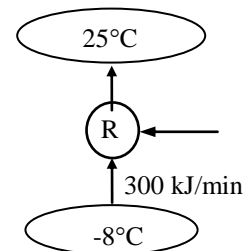

6-96 An inventor claims to have developed a refrigerator. The inventor reports temperature and COP measurements. The claim is to be evaluated.

Analysis The highest coefficient of performance a refrigerator can have when removing heat from a cool medium at -12°C to a warmer medium at 25°C is

$$\text{COP}_{\text{R,max}} = \text{COP}_{\text{R,rev}} = \frac{1}{(T_H/T_L)-1} = \frac{1}{(25+273\text{ K})/(-12+273\text{ K})-1} = 7.1$$

The COP claimed by the inventor is 6.5, which is below this maximum value, thus the claim is **reasonable**. However, it is not probable.

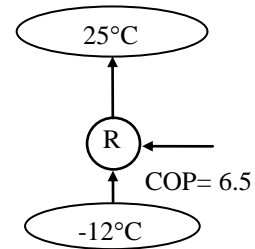

6-97 A heat pump maintains a house at a specified temperature. The rate of heat loss of the house and the power consumption of the heat pump are given. It is to be determined if this heat pump can do the job.

Assumptions The heat pump operates steadily.

Analysis The power input to a heat pump will be a minimum when the heat pump operates in a reversible manner. The coefficient of performance of a reversible heat pump depends on the temperature limits in the cycle only, and is determined from

$$\text{COP}_{\text{HP,rev}} = \frac{1}{1-(T_L/T_H)} = \frac{1}{1-(4+273\text{ K})/(25+273\text{ K})} = 14.19$$

The required power input to this reversible heat pump is determined from the definition of the coefficient of performance to be

$$\dot{W}_{\text{net,in,min}} = \frac{\dot{Q}_H}{\text{COP}_{\text{HP}}} = \frac{110,000\text{ kJ/h}}{14.19} \left(\frac{1\text{ h}}{3600\text{ s}} \right) = \mathbf{2.15\text{ kW}}$$

This heat pump is **powerful enough** since $4.75\text{ kW} > 2.15\text{ kW}$.

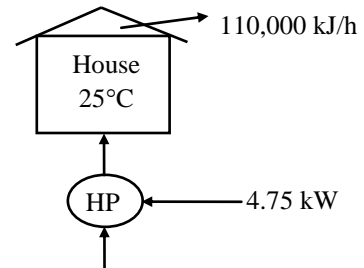

6-98E The power required by a reversible refrigerator with specified reservoir temperatures is to be determined.

Assumptions The refrigerator operates steadily.

Analysis The COP of this reversible refrigerator is

$$\text{COP}_{\text{R,max}} = \frac{T_L}{T_H - T_L} = \frac{450\text{ R}}{540\text{ R} - 450\text{ R}} = 5$$

Using this result in the coefficient of performance expression yields

$$\dot{W}_{\text{net,in}} = \frac{\dot{Q}_L}{\text{COP}_{\text{R,max}}} = \frac{15,000\text{ Btu/h}}{5} \left(\frac{1\text{ kW}}{3412.14\text{ Btu/h}} \right) = \mathbf{0.879\text{ kW}}$$

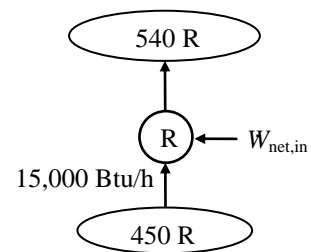

6-99E The cooled space and the outdoors temperatures for an air-conditioner and the power consumption are given. The maximum rate of heat removal from the air-conditioned space is to be determined.

Assumptions The air-conditioner operates steadily.

Analysis The rate of heat removal from a house will be a maximum when the air-conditioning system operates in a reversible manner. The coefficient of performance of a reversible air-conditioner (or refrigerator) depends on the temperature limits in the cycle only, and is determined from

$$\text{COP}_{\text{R,rev}} = \frac{1}{(T_H/T_L) - 1} = \frac{1}{(90 + 460 \text{ R})/(72 + 460 \text{ R}) - 1} = 29.6$$

The rate of heat removal from the house is determined from the definition of the coefficient of performance of a refrigerator,

$$\dot{Q}_L = \text{COP}_{\text{R}} \dot{W}_{\text{net,in}} = (29.6)(5 \text{ hp}) \left(\frac{42.41 \text{ Btu/min}}{1 \text{ hp}} \right) = \mathbf{6277 \text{ Btu/min}}$$

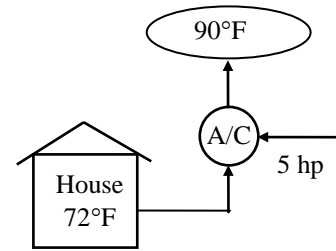

6-100 The power input and heat rejection of a reversed Carnot cycle are given. The cooling load and the source temperature are to be determined.

Assumptions The refrigerator operates steadily.

Analysis Applying the definition of the refrigerator coefficient of performance,

$$\dot{Q}_L = \dot{Q}_H - \dot{W}_{\text{net,in}} = 2000 - 200 = \mathbf{1800 \text{ kW}}$$

Applying the definition of the heat pump coefficient of performance,

$$\text{COP}_{\text{R}} = \frac{\dot{Q}_L}{\dot{W}_{\text{net,in}}} = \frac{1800 \text{ kW}}{200 \text{ kW}} = 9$$

The temperature of the heat source is determined from

$$\text{COP}_{\text{R,max}} = \frac{T_L}{T_H - T_L} \longrightarrow 9 = \frac{T_L}{300 - T_L} \longrightarrow T_L = 270 \text{ K} = \mathbf{-3^\circ\text{C}}$$

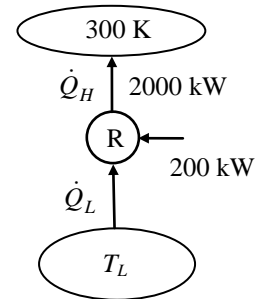

6-101 A commercial refrigerator with R-134a as the working fluid is considered. The condenser inlet and exit states are specified. The mass flow rate of the refrigerant, the refrigeration load, the COP, and the minimum power input to the compressor are to be determined.

Assumptions 1 The refrigerator operates steadily. **2** The kinetic and potential energy changes are zero.

Properties The properties of R-134a and water are (Steam and R-134a tables)

$$\left. \begin{array}{l} P_1 = 1.2 \text{ MPa} \\ T_1 = 50^\circ\text{C} \end{array} \right\} h_1 = 278.28 \text{ kJ/kg}$$

$$T_2 = T_{\text{sat}@1.2\text{MPa}} + \Delta T_{\text{subcool}} = 46.3 - 5 = 41.3^\circ\text{C}$$

$$\left. \begin{array}{l} P_2 = 1.2 \text{ MPa} \\ T_2 = 41.3^\circ\text{C} \end{array} \right\} h_2 = 110.19 \text{ kJ/kg}$$

$$\left. \begin{array}{l} T_{w,1} = 18^\circ\text{C} \\ x_{w,1} = 0 \end{array} \right\} h_{w,1} = 75.54 \text{ kJ/kg}$$

$$\left. \begin{array}{l} T_{w,2} = 26^\circ\text{C} \\ x_{w,2} = 0 \end{array} \right\} h_{w,2} = 109.01 \text{ kJ/kg}$$

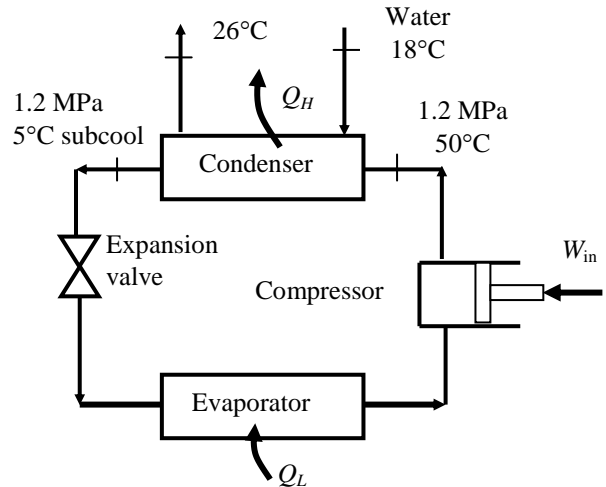

Analysis (a) The rate of heat transferred to the water is the energy change of the water from inlet to exit

$$\dot{Q}_H = \dot{m}_w (h_{w,2} - h_{w,1}) = (0.25 \text{ kg/s})(109.01 - 75.54) \text{ kJ/kg} = 8.367 \text{ kW}$$

The energy decrease of the refrigerant is equal to the energy increase of the water in the condenser. That is,

$$\dot{Q}_H = \dot{m}_R (h_1 - h_2) \longrightarrow \dot{m}_R = \frac{\dot{Q}_H}{h_1 - h_2} = \frac{8.367 \text{ kW}}{(278.28 - 110.19) \text{ kJ/kg}} = \mathbf{0.0498 \text{ kg/s}}$$

(b) The refrigeration load is

$$\dot{Q}_L = \dot{Q}_H - \dot{W}_{\text{in}} = 8.37 - 3.30 = \mathbf{5.07 \text{ kW}}$$

(c) The COP of the refrigerator is determined from its definition,

$$\text{COP} = \frac{\dot{Q}_L}{\dot{W}_{\text{in}}} = \frac{5.07 \text{ kW}}{3.3 \text{ kW}} = \mathbf{1.54}$$

(d) The COP of a reversible refrigerator operating between the same temperature limits is

$$\text{COP}_{\text{max}} = \frac{1}{T_H / T_L - 1} = \frac{1}{(18 + 273) / (-35 + 273) - 1} = 4.49$$

Then, the minimum power input to the compressor for the same refrigeration load would be

$$\dot{W}_{\text{in,min}} = \frac{\dot{Q}_L}{\text{COP}_{\text{max}}} = \frac{5.07 \text{ kW}}{4.49} = \mathbf{1.13 \text{ kW}}$$

6-102 A heat pump maintains a house at a specified temperature in winter. The maximum COPs of the heat pump for different outdoor temperatures are to be determined.

Analysis The coefficient of performance of a heat pump will be a maximum when the heat pump operates in a reversible manner. The coefficient of performance of a reversible heat pump depends on the temperature limits in the cycle only, and is determined for all three cases above to be

$$\text{COP}_{\text{HP,rev}} = \frac{1}{1 - (T_L / T_H)} = \frac{1}{1 - (10 + 273\text{K}) / (20 + 273\text{K})} = \mathbf{29.3}$$

$$\text{COP}_{\text{HP,rev}} = \frac{1}{1 - (T_L / T_H)} = \frac{1}{1 - (-5 + 273\text{K}) / (20 + 273\text{K})} = \mathbf{11.7}$$

$$\text{COP}_{\text{HP,rev}} = \frac{1}{1 - (T_L / T_H)} = \frac{1}{1 - (-30 + 273\text{K}) / (20 + 273\text{K})} = \mathbf{5.86}$$

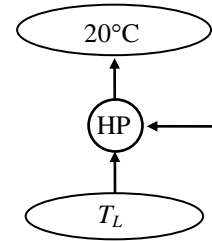

6-103E A heat pump maintains a house at a specified temperature. The rate of heat loss of the house is given. The minimum power inputs required for different source temperatures are to be determined.

Assumptions The heat pump operates steadily.

Analysis (a) The power input to a heat pump will be a minimum when the heat pump operates in a reversible manner. If the outdoor air at 25°F is used as the heat source, the COP of the heat pump and the required power input are determined to be

$$\begin{aligned} \text{COP}_{\text{HP,max}} = \text{COP}_{\text{HP,rev}} &= \frac{1}{1 - (T_L / T_H)} \\ &= \frac{1}{1 - (25 + 460 \text{ R}) / (78 + 460 \text{ R})} = 10.15 \end{aligned}$$

and

$$\dot{W}_{\text{net,in,min}} = \frac{\dot{Q}_H}{\text{COP}_{\text{HP,max}}} = \frac{70,000 \text{ Btu/h}}{10.15} \left(\frac{1 \text{ hp}}{2545 \text{ Btu/h}} \right) = \mathbf{2.71 \text{ hp}}$$

(b) If the well-water at 50°F is used as the heat source, the COP of the heat pump and the required power input are determined to be

$$\text{COP}_{\text{HP,max}} = \text{COP}_{\text{HP,rev}} = \frac{1}{1 - (T_L / T_H)} = \frac{1}{1 - (50 + 460 \text{ R}) / (78 + 460 \text{ R})} = 19.2$$

and

$$\dot{W}_{\text{net,in,min}} = \frac{\dot{Q}_H}{\text{COP}_{\text{HP,max}}} = \frac{70,000 \text{ Btu/h}}{19.2} \left(\frac{1 \text{ hp}}{2545 \text{ Btu/h}} \right) = \mathbf{1.43 \text{ hp}}$$

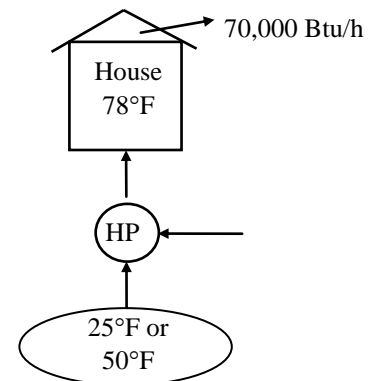

6-104 A Carnot heat pump consumes 4.8-kW of power when operating, and maintains a house at a specified temperature. The average rate of heat loss of the house in a particular day is given. The actual running time of the heat pump that day, the heating cost, and the cost if resistance heating is used instead are to be determined.

Analysis (a) The coefficient of performance of this Carnot heat pump depends on the temperature limits in the cycle only, and is determined from

$$\text{COP}_{\text{HP,rev}} = \frac{1}{1 - (T_L / T_H)} = \frac{1}{1 - (2 + 273 \text{ K}) / (25 + 273 \text{ K})} = 12.96$$

The amount of heat lost by the house that day is

$$Q_H = \dot{Q}_H (1 \text{ day}) = (55,000 \text{ kJ/h})(24 \text{ h}) = 1,320,000 \text{ kJ}$$

Then the required work input to this Carnot heat pump is determined from the definition of the coefficient of performance to be

$$W_{\text{net,in}} = \frac{Q_H}{\text{COP}_{\text{HP}}} = \frac{1,320,000 \text{ kJ}}{12.96} = 101,880 \text{ kJ}$$

Thus the length of time the heat pump ran that day is

$$\Delta t = \frac{W_{\text{net,in}}}{\dot{W}_{\text{net,in}}} = \frac{101,880 \text{ kJ}}{4.8 \text{ kJ/s}} = 21,225 \text{ s} = \mathbf{5.90 \text{ h}}$$

(b) The total heating cost that day is

$$\text{Cost} = W \times \text{price} = (\dot{W}_{\text{net,in}} \times \Delta t)(\text{price}) = (4.8 \text{ kW})(5.90 \text{ h})(0.11 \text{ \$/kWh}) = \mathbf{\$3.11}$$

(c) If resistance heating were used, the entire heating load for that day would have to be met by electrical energy. Therefore, the heating system would consume 1,320,000 kJ of electricity that would cost

$$\text{New Cost} = Q_H \times \text{price} = (1,320,000 \text{ kJ}) \left(\frac{1 \text{ kWh}}{3600 \text{ kJ}} \right) (0.11 \text{ \$/kWh}) = \mathbf{\$40.3}$$

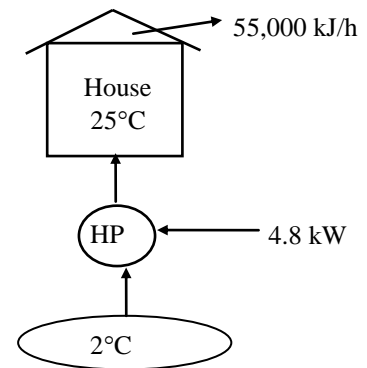

6-105 A Carnot heat engine is used to drive a Carnot refrigerator. The maximum rate of heat removal from the refrigerated space and the total rate of heat rejection to the ambient air are to be determined.

Assumptions The heat engine and the refrigerator operate steadily.

Analysis (a) The highest thermal efficiency a heat engine operating between two specified temperature limits can have is the Carnot efficiency, which is determined from

$$\eta_{\text{th,max}} = \eta_{\text{th,C}} = 1 - \frac{T_L}{T_H} = 1 - \frac{300 \text{ K}}{1173 \text{ K}} = 0.744$$

Then the maximum power output of this heat engine is determined from the definition of thermal efficiency to be

$$\dot{W}_{\text{net,out}} = \eta_{\text{th}} \dot{Q}_H = (0.744)(800 \text{ kJ/min}) = 595.2 \text{ kJ/min}$$

which is also the power input to the refrigerator, $\dot{W}_{\text{net,in}}$.

The rate of heat removal from the refrigerated space will be a maximum if a Carnot refrigerator is used. The COP of the Carnot refrigerator is

$$\text{COP}_{\text{R,rev}} = \frac{1}{(T_H/T_L) - 1} = \frac{1}{(27 + 273 \text{ K})/(-5 + 273 \text{ K}) - 1} = 8.37$$

Then the rate of heat removal from the refrigerated space becomes

$$\dot{Q}_{L,R} = (\text{COP}_{\text{R,rev}})(\dot{W}_{\text{net,in}}) = (8.37)(595.2 \text{ kJ/min}) = \mathbf{4982 \text{ kJ/min}}$$

(b) The total rate of heat rejection to the ambient air is the sum of the heat rejected by the heat engine ($\dot{Q}_{L,\text{HE}}$) and the heat discarded by the refrigerator ($\dot{Q}_{H,R}$),

$$\dot{Q}_{L,\text{HE}} = \dot{Q}_{H,\text{HE}} - \dot{W}_{\text{net,out}} = 800 - 595.2 = 204.8 \text{ kJ/min}$$

$$\dot{Q}_{H,R} = \dot{Q}_{L,R} + \dot{W}_{\text{net,in}} = 4982 + 595.2 = 5577.2 \text{ kJ/min}$$

and

$$\dot{Q}_{\text{ambient}} = \dot{Q}_{L,\text{HE}} + \dot{Q}_{H,R} = 204.8 + 5577.2 = \mathbf{5782 \text{ kJ/min}}$$

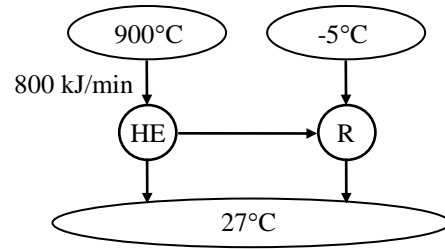

6-106E A Carnot heat engine is used to drive a Carnot refrigerator. The maximum rate of heat removal from the refrigerated space and the total rate of heat rejection to the ambient air are to be determined.

Assumptions The heat engine and the refrigerator operate steadily.

Analysis (a) The highest thermal efficiency a heat engine operating between two specified temperature limits can have is the Carnot efficiency, which is determined from

$$\eta_{th,max} = \eta_{th,C} = 1 - \frac{T_L}{T_H} = 1 - \frac{540 \text{ R}}{2160 \text{ R}} = 0.75$$

Then the maximum power output of this heat engine is determined from the definition of thermal efficiency to be

$$\dot{W}_{net,out} = \eta_{th} \dot{Q}_H = (0.75)(700 \text{ Btu/min}) = 525 \text{ Btu/min}$$

which is also the power input to the refrigerator, $\dot{W}_{net,in}$.

The rate of heat removal from the refrigerated space will be a maximum if a Carnot refrigerator is used. The COP of the Carnot refrigerator is

$$COP_{R,rev} = \frac{1}{(T_H/T_L) - 1} = \frac{1}{(80 + 460 \text{ R})/(20 + 460 \text{ R}) - 1} = 8.0$$

Then the rate of heat removal from the refrigerated space becomes

$$\dot{Q}_{L,R} = (COP_{R,rev})(\dot{W}_{net,in}) = (8.0)(525 \text{ Btu/min}) = \mathbf{4200 \text{ Btu/min}}$$

(b) The total rate of heat rejection to the ambient air is the sum of the heat rejected by the heat engine ($\dot{Q}_{L,HE}$) and the heat discarded by the refrigerator ($\dot{Q}_{H,R}$),

$$\dot{Q}_{L,HE} = \dot{Q}_{H,HE} - \dot{W}_{net,out} = 700 - 525 = 175 \text{ Btu/min}$$

$$\dot{Q}_{H,R} = \dot{Q}_{L,R} + \dot{W}_{net,in} = 4200 + 525 = 4725 \text{ Btu/min}$$

and

$$\dot{Q}_{ambient} = \dot{Q}_{L,HE} + \dot{Q}_{H,R} = 175 + 4725 = \mathbf{4900 \text{ Btu/min}}$$

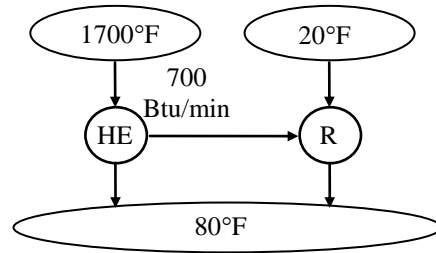

6-107 A heat pump that consumes 4-kW of power when operating maintains a house at a specified temperature. The house is losing heat in proportion to the temperature difference between the indoors and the outdoors. The lowest outdoor temperature for which this heat pump can do the job is to be determined.

Assumptions The heat pump operates steadily.

Analysis Denoting the outdoor temperature by T_L , the heating load of this house can be expressed as

$$\dot{Q}_H = (3800 \text{ kJ/h} \cdot \text{K})(297 - T_L) = (1.056 \text{ kW/K})(297 - T_L)\text{K}$$

The coefficient of performance of a Carnot heat pump depends on the temperature limits in the cycle only, and can be expressed as

$$COP_{HP} = \frac{1}{1 - (T_L/T_H)} = \frac{1}{1 - T_L/(297 \text{ K})}$$

or

$$COP_{HP} = \frac{\dot{Q}_H}{\dot{W}_{net,in}} = \frac{(1.056 \text{ kW/K})(297 - T_L)\text{K}}{4 \text{ kW}}$$

Equating the two relations above and solving for T_L , we obtain

$$T_L = 263.5 \text{ K} = \mathbf{-9.5^\circ\text{C}}$$

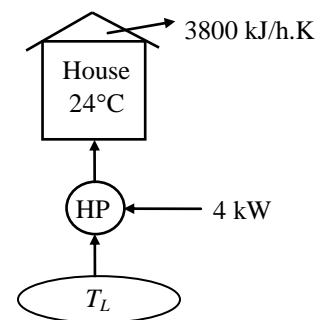

6-108 An air-conditioner with R-134a as the working fluid is considered. The compressor inlet and exit states are specified. The actual and maximum COPs and the minimum volume flow rate of the refrigerant at the compressor inlet are to be determined.

Assumptions 1 The air-conditioner operates steadily. 2 The kinetic and potential energy changes are zero.

Properties The properties of R-134a at the compressor inlet and exit states are (Tables A-11 through A-13)

$$\left. \begin{array}{l} P_1 = 400 \text{ kPa} \\ x_1 = 1 \end{array} \right\} \begin{array}{l} h_1 = 255.61 \text{ kJ/kg} \\ \nu_1 = 0.05127 \text{ m}^3/\text{kg} \end{array}$$

$$\left. \begin{array}{l} P_2 = 1.2 \text{ MPa} \\ T_2 = 70^\circ\text{C} \end{array} \right\} h_2 = 300.63 \text{ kJ/kg}$$

Analysis (a) The mass flow rate of the refrigerant and the power consumption of the compressor are

$$\dot{m}_R = \frac{\dot{V}_1}{\nu_1} = \frac{80 \text{ L/min} \left(\frac{1 \text{ m}^3}{1000 \text{ L}} \right) \left(\frac{1 \text{ min}}{60 \text{ s}} \right)}{0.05127 \text{ m}^3/\text{kg}} = 0.02601 \text{ kg/s}$$

$$\dot{W}_{\text{in}} = \dot{m}_R (h_2 - h_1) = (0.02601 \text{ kg/s})(300.63 - 255.61) \text{ kJ/kg} = 1.171 \text{ kW}$$

The heat gains to the room must be rejected by the air-conditioner. That is,

$$\dot{Q}_L = \dot{Q}_{\text{heat}} + \dot{Q}_{\text{equipment}} = (250 \text{ kJ/min}) \left(\frac{1 \text{ min}}{60 \text{ s}} \right) + 0.9 \text{ kW} = 5.067 \text{ kW}$$

Then, the actual COP becomes

$$\text{COP} = \frac{\dot{Q}_L}{\dot{W}_{\text{in}}} = \frac{5.067 \text{ kW}}{1.171 \text{ kW}} = \mathbf{4.33}$$

(b) The COP of a reversible refrigerator operating between the same temperature limits is

$$\text{COP}_{\text{max}} = \frac{1}{T_H / T_L - 1} = \frac{1}{(34 + 273)/(23 + 273) - 1} = \mathbf{26.91}$$

(c) The minimum power input to the compressor for the same refrigeration load would be

$$\dot{W}_{\text{in, min}} = \frac{\dot{Q}_L}{\text{COP}_{\text{max}}} = \frac{5.067 \text{ kW}}{26.91} = 0.1883 \text{ kW}$$

The minimum mass flow rate is

$$\dot{m}_{R, \text{min}} = \frac{\dot{W}_{\text{in, min}}}{h_2 - h_1} = \frac{0.1883 \text{ kW}}{(300.63 - 255.61) \text{ kJ/kg}} = 0.004182 \text{ kg/s}$$

Finally, the minimum volume flow rate at the compressor inlet is

$$\dot{V}_{\text{min, 1}} = \dot{m}_{R, \text{min}} \nu_1 = (0.004182 \text{ kg/s})(0.05127 \text{ m}^3/\text{kg}) = 0.0002144 \text{ m}^3/\text{s} = \mathbf{12.9 \text{ L/min}}$$

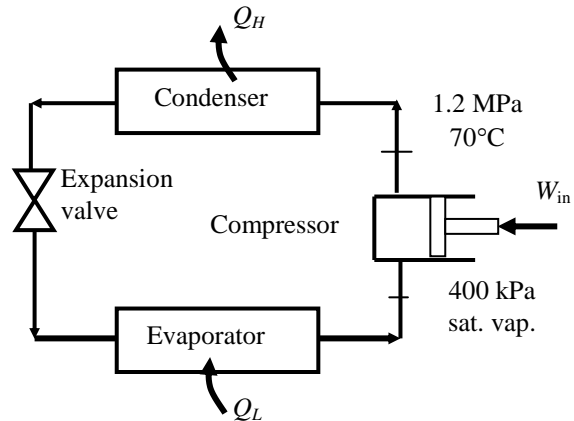

6-109 An expression for the COP of a completely reversible refrigerator in terms of the thermal-energy reservoir temperatures, T_L and T_H is to be derived.

Assumptions The refrigerator operates steadily.

Analysis Application of the first law to the completely reversible refrigerator yields

$$W_{\text{net,in}} = Q_H - Q_L$$

This result may be used to reduce the coefficient of performance,

$$\text{COP}_{\text{R,rev}} = \frac{Q_L}{W_{\text{net,in}}} = \frac{Q_L}{Q_H - Q_L} = \frac{1}{Q_H / Q_L - 1}$$

Since this refrigerator is completely reversible, the thermodynamic definition of temperature tells us that,

$$\frac{Q_H}{Q_L} = \frac{T_H}{T_L}$$

When this is substituted into the COP expression, the result is

$$\text{COP}_{\text{R,rev}} = \frac{1}{T_H / T_L - 1} = \frac{T_L}{T_H - T_L}$$

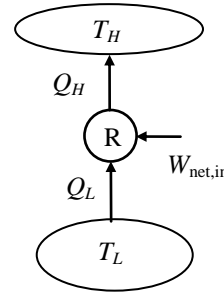

Special Topic: Household Refrigerators

6-110C Today's refrigerators are much more efficient than those built in the past as a result of using smaller and higher efficiency motors and compressors, better insulation materials, larger coil surface areas, and better door seals.

6-111C The energy consumption of a household refrigerator can be reduced by practicing good conservation measures such as (1) opening the refrigerator door the fewest times possible and for the shortest duration possible, (2) cooling the hot foods to room temperature first before putting them into the refrigerator, (3) cleaning the condenser coils behind the refrigerator, (4) checking the door gasket for air leaks, (5) avoiding unnecessarily low temperature settings, (6) avoiding excessive ice build-up on the interior surfaces of the evaporator, (7) using the power-saver switch that controls the heating coils that prevent condensation on the outside surfaces in humid environments, and (8) not blocking the air flow passages to and from the condenser coils of the refrigerator.

6-112C It is important to clean the condenser coils of a household refrigerator a few times a year since the dust that collects on them serves as insulation and slows down heat transfer. Also, it is important not to block air flow through the condenser coils since heat is rejected through them by natural convection, and blocking the air flow will interfere with this heat rejection process. A refrigerator cannot work unless it can reject the waste heat.

6-113C It is a bad idea to overdesign the refrigeration system of a supermarket so that the entire air-conditioning needs of the store can be met by refrigerated air without installing any air-conditioning system. This is because the refrigerators cool the air to a much lower temperature than needed for air conditioning, and thus their efficiency is much lower, and their operating cost is much higher.

6-114C It is a bad idea to meet the entire refrigerator/freezer requirements of a store by using a large freezer that supplies sufficient cold air at -20°C instead of installing separate refrigerators and freezers. This is because the freezers cool the air to a much lower temperature than needed for refrigeration, and thus their efficiency is much lower, and their operating cost is much higher.

6-115 A refrigerator consumes 400 W when running, and \$170 worth of electricity per year under normal use. The fraction of the time the refrigerator will run in a year is to be determined.

Assumptions The electricity consumed by the light bulb is negligible.

Analysis The total amount of electricity the refrigerator uses a year is

$$\text{Total electric energy used} = W_{e,\text{total}} = \frac{\text{Total cost of energy}}{\text{Unit cost of energy}} = \frac{\$170/\text{year}}{\$0.125/\text{kWh}} = 1360 \text{ kWh/year}$$

The number of hours the refrigerator is on per year is

$$\text{Total operating hours} = \Delta t = \frac{W_{e,\text{total}}}{\dot{W}_e} = \frac{1360 \text{ kWh/year}}{0.400 \text{ kW}} = 3400 \text{ h/year}$$

Noting that there are $365 \times 24 = 8760$ hours in a year, the fraction of the time the refrigerator is on during a year is determined to be

$$\text{Time fraction on} = \frac{\text{Total operating hours}}{\text{Total hours per year}} = \frac{3400/\text{year}}{8760 \text{ h/year}} = \mathbf{0.388}$$

Therefore, the refrigerator remained on 38.8% of the time.



6-116 The light bulb of a refrigerator is to be replaced by a \$25 energy efficient bulb that consumes less than half the electricity. It is to be determined if the energy savings of the efficient light bulb justify its cost.

Assumptions The new light bulb remains on the same number of hours a year.

Analysis The lighting energy saved a year by the energy efficient bulb is

$$\begin{aligned} \text{Lighting energy saved} &= (\text{Lighting power saved})(\text{Operating hours}) \\ &= [(40 - 18)\text{W}](60 \text{ h/year}) \\ &= 1320 \text{ Wh} = 1.32 \text{ kWh} \end{aligned}$$

This means 1.32 kWh less heat is supplied to the refrigerated space by the light bulb, which must be removed from the refrigerated space. This corresponds to a refrigeration savings of

$$\text{Refrigeration energy saved} = \frac{\text{Lighting energy saved}}{\text{COP}} = \frac{1.32 \text{ kWh}}{1.3} = 1.02 \text{ kWh}$$

Then the total electrical energy and money saved by the energy efficient light bulb become

$$\begin{aligned} \text{Total energy saved} &= (\text{Lighting} + \text{Refrigeration}) \text{ energy saved} = 1.32 + 1.02 = 2.34 \text{ kWh/year} \\ \text{Money saved} &= (\text{Total energy saved})(\text{Unit cost of energy}) = (2.34 \text{ kWh/year})(\$0.08/\text{kWh}) \\ &= \mathbf{\$0.19/\text{year}} \end{aligned}$$

That is, the light bulb will save only 19 cents a year in energy costs, and it will take $\$25/\$0.19 = 132$ years for it to pay for itself from the energy it saves. Therefore, it is **not justified** in this case.

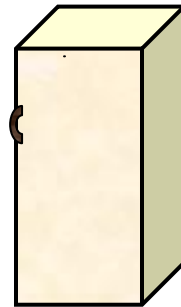

6-117 A person cooks three times a week and places the food into the refrigerator before cooling it first. The amount of money this person will save a year by cooling the hot foods to room temperature before refrigerating them is to be determined.

Assumptions **1** The heat stored in the pan itself is negligible. **2** The specific heat of the food is constant.

Properties The specific heat of food is $c = 3.90 \text{ kJ/kg}\cdot^\circ\text{C}$ (given).

Analysis The amount of hot food refrigerated per year is

$$m_{\text{food}} = (5 \text{ kg/pan})(3 \text{ pans/week})(52 \text{ weeks/year}) = 780 \text{ kg/year}$$

The amount of energy removed from food as it is unnecessarily cooled to room temperature in the refrigerator is

$$\text{Energy removed} = Q_{\text{out}} = m_{\text{food}}c\Delta T = (780 \text{ kg/year})(3.90 \text{ kJ/kg}\cdot^\circ\text{C})(95 - 23)^\circ\text{C} = 219,024 \text{ kJ/year}$$

$$\text{Energy saved} = E_{\text{saved}} = \frac{\text{Energy removed}}{\text{COP}} = \frac{219,024 \text{ kJ/year}}{1.5} \left(\frac{1 \text{ kWh}}{3600 \text{ kJ}} \right) = 40.56 \text{ kWh/year}$$

$$\text{Money saved} = (\text{Energy saved})(\text{Unit cost of energy}) = (40.56 \text{ kWh/year})(\$0.10/\text{kWh}) = \mathbf{\$4.06/\text{year}}$$

Therefore, cooling the food to room temperature before putting it into the refrigerator will save about four dollars a year.

6-118 The door of a refrigerator is opened 8 times a day, and half of the cool air inside is replaced by the warmer room air. The cost of the energy wasted per year as a result of opening the refrigerator door is to be determined for the cases of moist and dry air in the room.

Assumptions 1 The room is maintained at 20°C and 95 kPa at all times. **2** Air is an ideal gas with constant specific heats at room temperature. **3** The moisture is condensed at an average temperature of 4°C. **4** Half of the air volume in the refrigerator is replaced by the warmer kitchen air each time the door is opened.

Properties The gas constant of air is $R = 0.287 \text{ kPa}\cdot\text{m}^3/\text{kg}\cdot\text{K}$ (Table A-1). The specific heat of air at room temperature is $c_p = 1.005 \text{ kJ/kg}\cdot^\circ\text{C}$ (Table A-2a). The heat of vaporization of water at 4°C is $h_{fg} = 2491.4 \text{ kJ/kg}$ (Table A-4).

Analysis The volume of the refrigerated air replaced each time the refrigerator is opened is 0.3 m^3 (half of the 0.6 m^3 air volume in the refrigerator). Then the total volume of refrigerated air replaced by room air per year is

$$V_{\text{air, replaced}} = (0.3 \text{ m}^3)(20/\text{day})(365 \text{ days/year}) = 2190 \text{ m}^3/\text{year}$$

The density of air at the refrigerated space conditions of 95 kPa and 4°C and the mass of air replaced per year are

$$\rho_o = \frac{P_o}{RT_o} = \frac{95 \text{ kPa}}{(0.287 \text{ kPa}\cdot\text{m}^3/\text{kg}\cdot\text{K})(4 + 273 \text{ K})} = 1.195 \text{ kg/m}^3$$

$$m_{\text{air}} = \rho V_{\text{air}} = (1.195 \text{ kg/m}^3)(2190 \text{ m}^3/\text{year}) = 2617 \text{ kg/year}$$

The amount of moisture condensed and removed by the refrigerator is

$$\begin{aligned} m_{\text{moisture}} &= m_{\text{air}} (\text{moisture removed per kg air}) \\ &= (2617 \text{ kg air/year})(0.006 \text{ kg/kg air}) \\ &= 15.70 \text{ kg/year} \end{aligned}$$

The sensible, latent, and total heat gains of the refrigerated space become

$$\begin{aligned} Q_{\text{gain, sensible}} &= m_{\text{air}} c_p (T_{\text{room}} - T_{\text{refrig}}) \\ &= (2617 \text{ kg/year})(1.005 \text{ kJ/kg}\cdot^\circ\text{C})(20 - 4)^\circ\text{C} = 42,082 \text{ kJ/year} \end{aligned}$$

$$\begin{aligned} Q_{\text{gain, latent}} &= m_{\text{moisture}} h_{fg} \\ &= (15.70 \text{ kg/year})(2491.4 \text{ kJ/kg}) = 39,121 \text{ kJ/year} \end{aligned}$$

$$Q_{\text{gain, total}} = Q_{\text{gain, sensible}} + Q_{\text{gain, latent}} = 42,082 + 39,121 = 81,202 \text{ kJ/year}$$

For a COP of 1.4, the amount of electrical energy the refrigerator will consume to remove this heat from the refrigerated space and its cost are

$$\text{Electrical energy used (total)} = \frac{Q_{\text{gain, total}}}{\text{COP}} = \frac{81,202 \text{ kJ/year}}{1.4} \left(\frac{1 \text{ kWh}}{3600 \text{ kJ}} \right) = 16.11 \text{ kWh/year}$$

$$\begin{aligned} \text{Cost of energy used (total)} &= (\text{Energy used})(\text{Unit cost of energy}) \\ &= (16.11 \text{ kWh/year})(\$0.115/\text{kWh}) \\ &= \mathbf{\$1.85/\text{year}} \end{aligned}$$

If the room air is very dry and thus latent heat gain is negligible, then the amount of electrical energy the refrigerator will consume to remove the sensible heat from the refrigerated space and its cost become

$$\text{Electrical energy used (sensible)} = \frac{Q_{\text{gain, sensible}}}{\text{COP}} = \frac{42,082 \text{ kJ/year}}{1.4} \left(\frac{1 \text{ kWh}}{3600 \text{ kJ}} \right) = 8.350 \text{ kWh/year}$$

$$\begin{aligned} \text{Cost of energy used (sensible)} &= (\text{Energy used})(\text{Unit cost of energy}) \\ &= (8.350 \text{ kWh/year})(\$0.115/\text{kWh}) \\ &= \mathbf{\$0.96/\text{year}} \end{aligned}$$

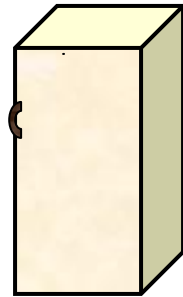

Review Problems

6-119 An air-conditioning system maintains a house at a specified temperature. The rate of heat gain of the house, the rate of internal heat generation, and the COP are given. The required power input is to be determined.

Assumptions Steady operating conditions exist.

Analysis The cooling load of this air-conditioning system is the sum of the heat gain from the outdoors and the heat generated in the house from the people, lights, and appliances:

$$\dot{Q}_L = 20,000 + 8,000 = 28,000 \text{ kJ/h}$$

Using the definition of the coefficient of performance, the power input to the air-conditioning system is determined to be

$$\dot{W}_{\text{net,in}} = \frac{\dot{Q}_L}{\text{COP}_R} = \frac{28,000 \text{ kJ/h}}{2.5} \left(\frac{1 \text{ kW}}{3600 \text{ kJ/h}} \right) = \mathbf{3.11 \text{ kW}}$$

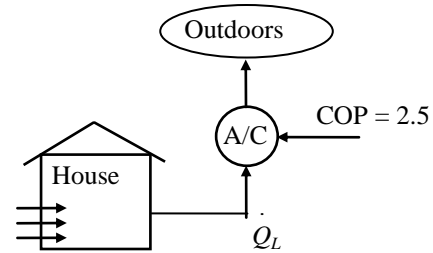

6-120E A Carnot heat pump maintains a house at a specified temperature. The rate of heat loss from the house and the outdoor temperature are given. The COP and the power input are to be determined.

Analysis (a) The coefficient of performance of this Carnot heat pump depends on the temperature limits in the cycle only, and is determined from

$$\text{COP}_{\text{HP,rev}} = \frac{1}{1 - (T_L/T_H)} = \frac{1}{1 - (35 + 460 \text{ R})/(75 + 460 \text{ R})} = \mathbf{13.4}$$

(b) The heating load of the house is

$$\dot{Q}_H = (2500 \text{ Btu/h} \cdot ^\circ\text{F})(75 - 35)^\circ\text{F} = 100,000 \text{ Btu/h}$$

Then the required power input to this Carnot heat pump is determined from the definition of the coefficient of performance to be

$$\dot{W}_{\text{net,in}} = \frac{\dot{Q}_H}{\text{COP}_{\text{HP}}} = \frac{100,000 \text{ Btu/h}}{13.4} \left(\frac{1 \text{ hp}}{2545 \text{ Btu/h}} \right) = \mathbf{2.93 \text{ hp}}$$

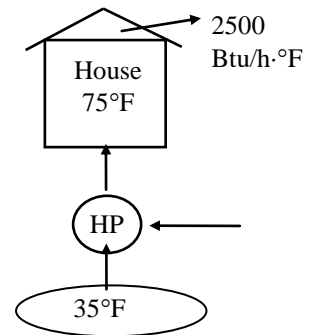

6-121 The work output and the source and sink temperatures of a Carnot heat engine are given. The heat supplied to and rejected from the heat engine are to be determined.

Assumptions 1 The heat engine operates steadily. 2 Heat losses from the working fluid at the pipes and other components are negligible.

Analysis Applying the definition of the thermal efficiency and an energy balance to the heat engine, the unknown parameters are determined as follows:

$$\eta_{\text{th,max}} = 1 - \frac{T_L}{T_H} = 1 - \frac{(50 + 273) \text{ K}}{(1200 + 273) \text{ K}} = 0.781$$

$$Q_H = \frac{W_{\text{net}}}{\eta_{\text{th}}} = \frac{500 \text{ kJ}}{0.781} = \mathbf{640 \text{ kJ}}$$

$$Q_L = Q_H - W_{\text{net}} = 640 - 500 = \mathbf{140 \text{ kJ}}$$

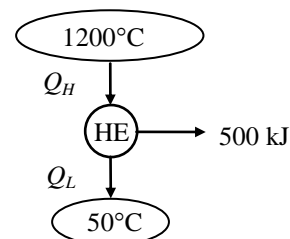

6-122E The operating conditions of a heat pump are given. The minimum temperature of the source that satisfies the second law of thermodynamics is to be determined.

Assumptions The heat pump operates steadily.

Analysis Applying the first law to this heat pump gives

$$\dot{Q}_L = \dot{Q}_H - \dot{W}_{\text{net,in}} = 32,000 \text{ Btu/h} - (1.8 \text{ kW}) \left(\frac{3412.14 \text{ Btu/h}}{1 \text{ kW}} \right) = 25,860 \text{ Btu/h}$$

In the reversible case we have

$$\frac{T_L}{T_H} = \frac{\dot{Q}_L}{\dot{Q}_H}$$

Then the minimum temperature may be determined to be

$$T_L = T_H \frac{\dot{Q}_L}{\dot{Q}_H} = (530 \text{ R}) \frac{25,860 \text{ Btu/h}}{32,000 \text{ Btu/h}} = \mathbf{428 \text{ R}}$$

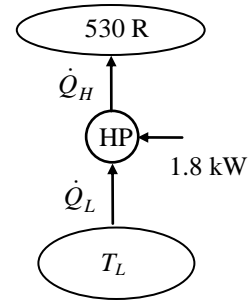

6-123E A refrigerator with a water-cooled condenser is considered. The cooling load and the COP of a refrigerator are given. The power input, the exit temperature of water, and the maximum possible COP of the refrigerator are to be determined.

Assumptions The refrigerator operates steadily.

Analysis (a) The power input is

$$\dot{W}_{\text{in}} = \frac{\dot{Q}_L}{\text{COP}} = \frac{24,000 \text{ Btu/h}}{1.9} \left(\frac{1.055 \text{ kJ}}{1 \text{ Btu}} \right) \left(\frac{1 \text{ h}}{3600 \text{ s}} \right) = \mathbf{3.702 \text{ kW}}$$

(b) The rate of heat rejected in the condenser is

$$\begin{aligned} \dot{Q}_H &= \dot{Q}_L + \dot{W}_{\text{in}} \\ &= 24,000 \text{ Btu/h} + 3.702 \text{ kW} \left(\frac{1 \text{ Btu}}{1.055 \text{ kJ}} \right) \left(\frac{3600 \text{ s}}{1 \text{ h}} \right) \\ &= \mathbf{36,632 \text{ Btu/h}} \end{aligned}$$

The exit temperature of the water is

$$\begin{aligned} \dot{Q}_H &= \dot{m} c_p (T_2 - T_1) \\ T_2 &= T_1 + \frac{\dot{Q}_H}{\dot{m} c_p} \\ &= 65^\circ\text{F} + \frac{36,632 \text{ Btu/h}}{(1.45 \text{ lbm/s}) \left(\frac{3600 \text{ s}}{1 \text{ h}} \right) (1.0 \text{ Btu/lbm} \cdot ^\circ\text{F})} = \mathbf{72.02^\circ\text{F}} \end{aligned}$$

(c) Taking the temperature of high-temperature medium to be the average temperature of water in the condenser,

$$\text{COP}_{\text{rev}} = \frac{T_L}{T_H - T_L} = \frac{25 + 460}{0.5(65 + 72.02) - 25} = \mathbf{11.2}$$

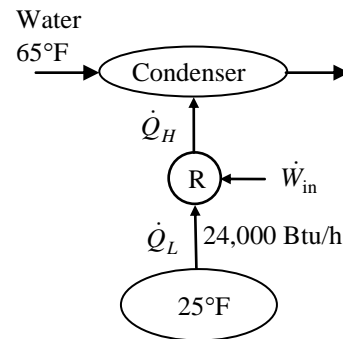

6-124 A heat pump with a specified COP and power consumption is used to heat a house. The time it takes for this heat pump to raise the temperature of a cold house to the desired level is to be determined.

Assumptions 1 Air is an ideal gas with constant specific heats at room temperature. **2** The heat loss of the house during the warm-up period is negligible. **3** The house is well-sealed so that no air leaks in or out.

Properties The constant volume specific heat of air at room temperature is $c_v = 0.718 \text{ kJ/kg}\cdot^\circ\text{C}$.

Analysis Since the house is well-sealed (constant volume), the total amount of heat that needs to be supplied to the house is

$$Q_H = (mc_v\Delta T)_{\text{house}} = (1500 \text{ kg})(0.718 \text{ kJ/kg}\cdot^\circ\text{C})(22 - 7)^\circ\text{C} = 16,155 \text{ kJ}$$

The rate at which this heat pump supplies heat is

$$\dot{Q}_H = \text{COP}_{\text{HP}}\dot{W}_{\text{net,in}} = (2.8)(5 \text{ kW}) = 14 \text{ kW}$$

That is, this heat pump can supply 14 kJ of heat per second. Thus the time required to supply 16,155 kJ of heat is

$$\Delta t = \frac{Q_H}{\dot{Q}_H} = \frac{16,155 \text{ kJ}}{14 \text{ kJ/s}} = 1154 \text{ s} = \mathbf{19.2 \text{ min}}$$

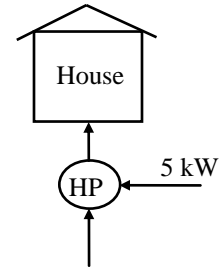

6-125 A solar pond power plant operates by absorbing heat from the hot region near the bottom, and rejecting waste heat to the cold region near the top. The maximum thermal efficiency that the power plant can have is to be determined.

Analysis The highest thermal efficiency a heat engine operating between two specified temperature limits can have is the Carnot efficiency, which is determined from

$$\eta_{\text{th,max}} = \eta_{\text{th,C}} = 1 - \frac{T_L}{T_H} = 1 - \frac{308 \text{ K}}{353 \text{ K}} = 0.127 \text{ or } \mathbf{12.7\%}$$

In reality, the temperature of the working fluid must be above 35°C in the condenser, and below 80°C in the boiler to allow for any effective heat transfer. Therefore, the maximum efficiency of the actual heat engine will be lower than the value calculated above.

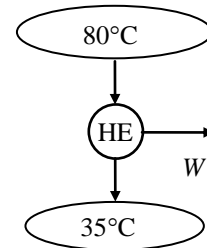

6-126 A Carnot refrigeration cycle is executed in a closed system with a fixed mass of R-134a. The net work input and the ratio of maximum-to-minimum temperatures are given. The minimum pressure in the cycle is to be determined.

Assumptions The refrigerator is said to operate on the reversed Carnot cycle, which is totally reversible.

Analysis The coefficient of performance of the cycle is

$$\text{COP}_R = \frac{1}{T_H / T_L - 1} = \frac{1}{1.2 - 1} = 5$$

Also,

$$\text{COP}_R = \frac{Q_L}{W_{\text{in}}} \longrightarrow Q_L = \text{COP}_R \times W_{\text{in}} = (5)(22 \text{ kJ}) = 110 \text{ kJ}$$

$$Q_H = Q_L + W = 110 + 22 = 132 \text{ kJ}$$

and

$$q_H = \frac{Q_H}{m} = \frac{132 \text{ kJ}}{0.96 \text{ kg}} = 137.5 \text{ kJ/kg} = h_{fg@T_H}$$

since the enthalpy of vaporization h_{fg} at a given T or P represents the amount of heat transfer per unit mass as a substance is converted from saturated liquid to saturated vapor at that T or P . Therefore, T_H is the temperature that corresponds to the h_{fg} value of 137.5 kJ/kg, and is determined from the R-134a tables to be

$$T_H \cong 61.3^\circ\text{C} = 334.3 \text{ K}$$

Then,

$$T_L = \frac{T_H}{1.2} = \frac{334.3 \text{ K}}{1.2} = 278.6 \text{ K} \cong 5.6^\circ\text{C}$$

Therefore,

$$P_{\text{min}} = P_{\text{sat}@5.6^\circ\text{C}} = \mathbf{356 \text{ kPa}}$$

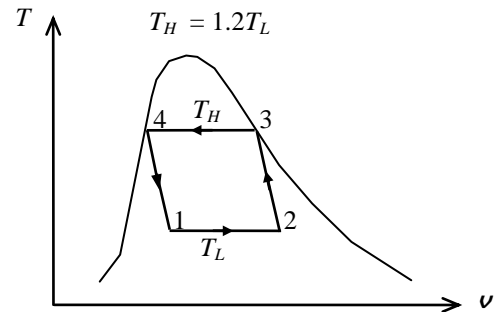



6-127 Problem 6-126 is reconsidered. The effect of the net work input on the minimum pressure as the work input varies from 10 kJ to 30 kJ is to be investigated. The minimum pressure in the refrigeration cycle is to be plotted as a function of net work input.

Analysis The problem is solved using EES, and the results are tabulated and plotted below.

Analysis: The coefficient of performance of the cycle is given by"

$$m_{R134a} = 0.96 \text{ [kg]}$$

$$THtoTLRatio = 1.2 \text{ "T}_H = 1.2T_L\text{"}$$

$$\text{"W}_{in} = 22 \text{ [kJ]"} \text{ "Depending on the value of W}_{in}, \text{ adjust the guess value of T}_H\text{."}$$

$$COP_R = 1 / (THtoTLRatio - 1)$$

$$Q_L = W_{in} * COP_R$$

"First law applied to the refrigeration cycle yields:"

$$Q_L + W_{in} = Q_H$$

"Steady-flow analysis of the condenser yields

$$m_{R134a} * h_3 = m_{R134a} * h_4 + Q_H$$

$$Q_H = m_{R134a} * (h_3 - h_4) \text{ and } h_{fg} = h_3 - h_4 \text{ also } T_H = T_3 = T_4"$$

$$Q_H = m_{R134a} * h_{fg}$$

$$h_{fg} = \text{enthalpy}(R134a, T=T_H, x=1) - \text{enthalpy}(R134a, T=T_H, x=0)$$

$$T_H = THtoTLRatio * T_L$$

"The minimum pressure is the saturation pressure corresponding to T_L ."

$$P_{min} = \text{pressure}(R134a, T=T_L, x=0) * \text{convert}(kPa, MPa)$$

$$T_{L,C} = T_L - 273$$

W_{in} [kJ]	P_{min} [MPa]	T_H [K]	T_L [K]	$T_{L,C}$ [C]
10	0.8673	368.8	307.3	34.32
15	0.6837	358.9	299	26.05
20	0.45	342.7	285.6	12.61
25	0.2251	319.3	266.1	-6.907
30	0.06978	287.1	239.2	-33.78

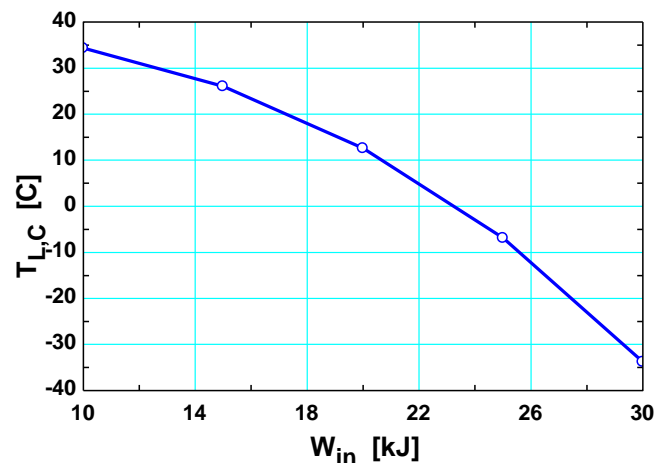
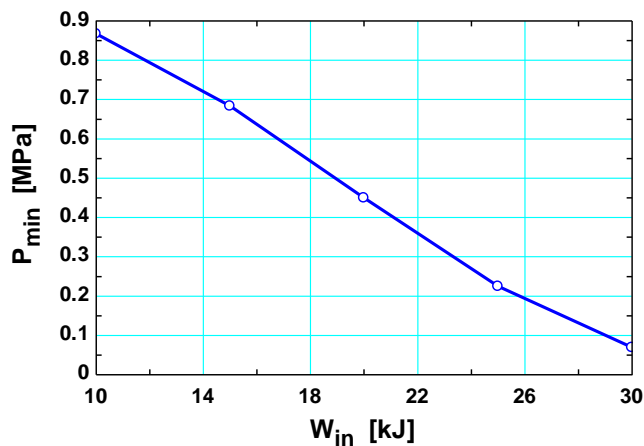

6-128 Two Carnot heat engines operate in series between specified temperature limits. If the thermal efficiencies of both engines are the same, the temperature of the intermediate medium between the two engines is to be determined.

Assumptions The engines are said to operate on the Carnot cycle, which is totally reversible.

Analysis The thermal efficiency of the two Carnot heat engines can be expressed as

$$\eta_{\text{th,I}} = 1 - \frac{T}{T_H} \quad \text{and} \quad \eta_{\text{th,II}} = 1 - \frac{T_L}{T}$$

Equating,

$$1 - \frac{T}{T_H} = 1 - \frac{T_L}{T}$$

Solving for T ,

$$T = \sqrt{T_H T_L} = \sqrt{(1400 \text{ K})(300 \text{ K})} = \mathbf{648 \text{ K}}$$

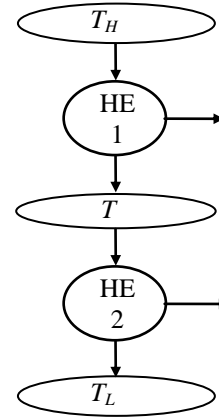

6-129 A Carnot heat engine drives a Carnot refrigerator that removes heat from a cold medium at a specified rate. The rate of heat supply to the heat engine and the total rate of heat rejection to the environment are to be determined.

Analysis (a) The coefficient of performance of the Carnot refrigerator is

$$\text{COP}_{\text{R,C}} = \frac{1}{(T_H/T_L) - 1} = \frac{1}{(300 \text{ K})/(258 \text{ K}) - 1} = 6.143$$

Then power input to the refrigerator becomes

$$\dot{W}_{\text{net,in}} = \frac{\dot{Q}_L}{\text{COP}_{\text{R,C}}} = \frac{250 \text{ kJ/min}}{6.143} = 40.7 \text{ kJ/min}$$

which is equal to the power output of the heat engine, $\dot{W}_{\text{net,out}}$.

The thermal efficiency of the Carnot heat engine is determined from

$$\eta_{\text{th,C}} = 1 - \frac{T_L}{T_H} = 1 - \frac{300 \text{ K}}{900 \text{ K}} = 0.6667$$

Then the rate of heat input to this heat engine is determined from the definition of thermal efficiency to be

$$\dot{Q}_{H,\text{HE}} = \frac{\dot{W}_{\text{net,out}}}{\eta_{\text{th,HE}}} = \frac{40.7 \text{ kJ/min}}{0.6667} = \mathbf{61.1 \text{ kJ/min}}$$

(b) The total rate of heat rejection to the ambient air is the sum of the heat rejected by the heat engine ($\dot{Q}_{L,\text{HE}}$) and the heat discarded by the refrigerator ($\dot{Q}_{H,\text{R}}$),

$$\dot{Q}_{L,\text{HE}} = \dot{Q}_{H,\text{HE}} - \dot{W}_{\text{net,out}} = 61.1 - 40.7 = 20.4 \text{ kJ/min}$$

$$\dot{Q}_{H,\text{R}} = \dot{Q}_{L,\text{R}} + \dot{W}_{\text{net,in}} = 250 + 40.7 = 290.7 \text{ kJ/min}$$

and

$$\dot{Q}_{\text{Ambient}} = \dot{Q}_{L,\text{HE}} + \dot{Q}_{H,\text{R}} = 20.4 + 290.7 = \mathbf{311 \text{ kJ/min}}$$

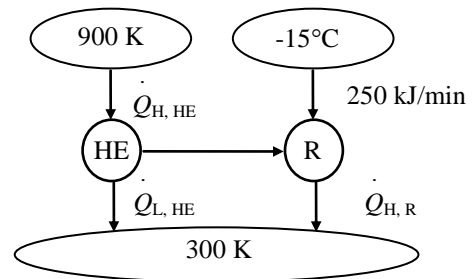



6-130 Problem 6-129 is reconsidered. The effects of the heat engine source temperature, the environment temperature, and the cooled space temperature on the required heat supply to the heat engine and the total rate of heat rejection to the environment as the source temperature varies from 500 K to 1000 K, the environment temperature varies from 275 K to 325 K, and the cooled space temperature varies from -20°C to 0°C are to be investigated. The required heat supply is to be plotted against the source temperature for the cooled space temperature of -15°C and environment temperatures of 275, 300, and 325 K.

Analysis The problem is solved using EES, and the results are tabulated and plotted below.

$Q_{\text{dot}_L_R} = 250 \text{ [kJ/min]}$
 $T_{\text{surr}} = 300 \text{ [K]}$
 $T_H = 900 \text{ [K]}$
 $T_{L_C} = -15 \text{ [C]}$
 $T_L = T_{L_C} + 273$

"Coefficient of performance of the Carnot refrigerator:"

$T_{H_R} = T_{\text{surr}}$
 $\text{COP}_R = 1 / (T_{H_R} / T_L - 1)$

"Power input to the refrigerator:"

$W_{\text{dot}_in_R} = Q_{\text{dot}_L_R} / \text{COP}_R$

"Power output from heat engine must be:"

$W_{\text{dot}_out_{HE}} = W_{\text{dot}_in_R}$

"The efficiency of the heat engine is:"

$T_{L_{HE}} = T_{\text{surr}}$
 $\eta_{HE} = 1 - T_{L_{HE}} / T_H$

"The rate of heat input to the heat engine is:"

$Q_{\text{dot}_H_{HE}} = W_{\text{dot}_out_{HE}} / \eta_{HE}$

"First law applied to the heat engine and refrigerator:"

$Q_{\text{dot}_L_{HE}} = Q_{\text{dot}_H_{HE}} - W_{\text{dot}_out_{HE}}$

$Q_{\text{dot}_H_R} = Q_{\text{dot}_L_R} + W_{\text{dot}_in_R}$

T_H [K]	Q_{HHE} [kJ/min]	Q_{surr} [kJ/min]
500	36.61	286.6
600	30.41	280.4
700	27.13	277.1
800	25.1	275.1
900	23.72	273.7
1000	22.72	272.7

T_{L_C} [C]	Q_{HHE} [kJ/min]	Q_{surr} [kJ/min]
-20	31.3	281.3
-18	28.24	278.2
-16	25.21	275.2
-14	22.24	272.2
-12	19.31	269.3
-10	16.43	266.4
-8	13.58	263.6
-6	10.79	260.8
-4	8.03	258
-2	5.314	255.3
0	2.637	252.6

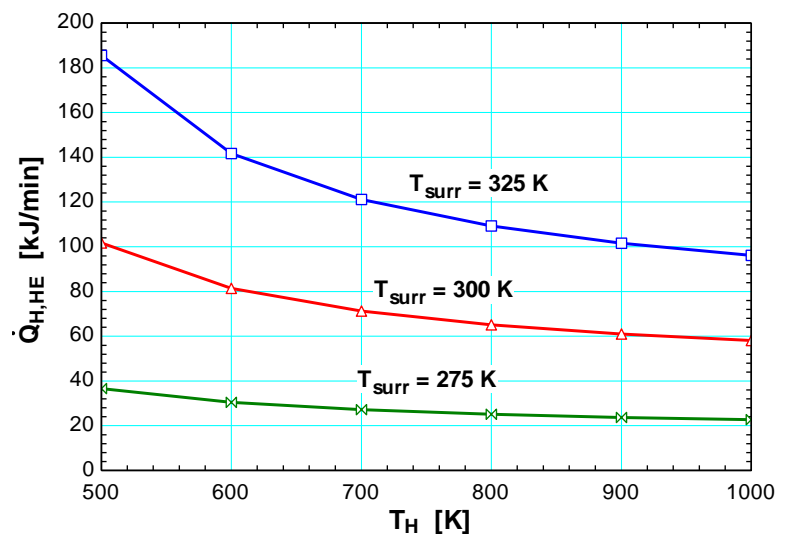

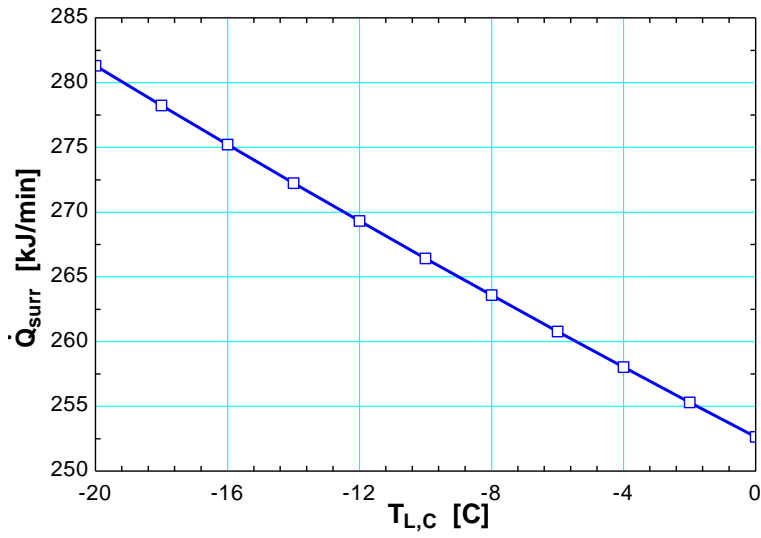
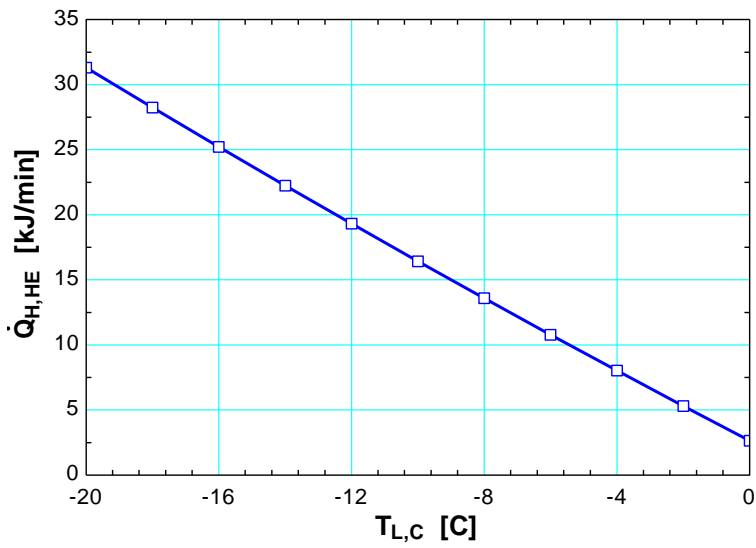
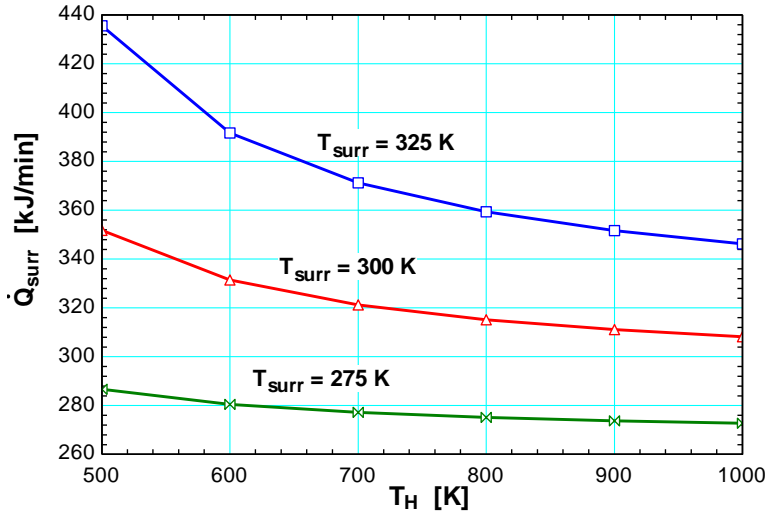

6-131 Half of the work output of a Carnot heat engine is used to drive a Carnot heat pump that is heating a house. The minimum rate of heat supply to the heat engine is to be determined.

Assumptions Steady operating conditions exist.

Analysis The coefficient of performance of the Carnot heat pump is

$$\text{COP}_{\text{HP,C}} = \frac{1}{1 - (T_L/T_H)} = \frac{1}{1 - (2 + 273 \text{ K})/(22 + 273 \text{ K})} = 14.75$$

Then power input to the heat pump, which is supplying heat to the house at the same rate as the rate of heat loss, becomes

$$\dot{W}_{\text{net,in}} = \frac{\dot{Q}_H}{\text{COP}_{\text{HP,C}}} = \frac{62,000 \text{ kJ/h}}{14.75} = 4203 \text{ kJ/h}$$

which is half the power produced by the heat engine. Thus the power output of the heat engine is

$$\dot{W}_{\text{net,out}} = 2\dot{W}_{\text{net,in}} = 2(4203 \text{ kJ/h}) = 8406 \text{ kJ/h}$$

To minimize the rate of heat supply, we must use a Carnot heat engine whose thermal efficiency is determined from

$$\eta_{\text{th,C}} = 1 - \frac{T_L}{T_H} = 1 - \frac{293 \text{ K}}{1073 \text{ K}} = 0.727$$

Then the rate of heat supply to this heat engine is determined from the definition of thermal efficiency to be

$$\dot{Q}_{H,\text{HE}} = \frac{\dot{W}_{\text{net,out}}}{\eta_{\text{th,HE}}} = \frac{8406 \text{ kJ/h}}{0.727} = \mathbf{11,560 \text{ kJ/h}}$$

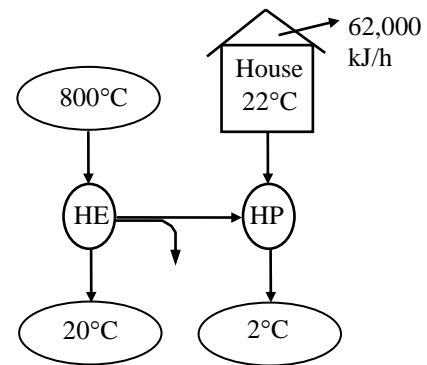

6-132E An extraordinary claim made for the performance of a refrigerator is to be evaluated.

Assumptions Steady operating conditions exist.

Analysis The performance of this refrigerator can be evaluated by comparing it with a reversible refrigerator operating between the same temperature limits:

$$\text{COP}_{\text{R,max}} = \text{COP}_{\text{R,rev}} = \frac{1}{T_H/T_L - 1} = \frac{1}{(85 + 460)/(40 + 460) - 1} = 11.1$$

Discussion This is the highest COP a refrigerator can have when absorbing heat from a cool medium at 40°F and rejecting it to a warmer medium at 85°F. Since the COP claimed by the inventor is above this maximum value, **the claim is false**.

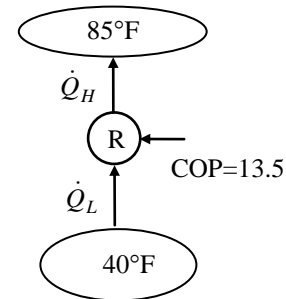

6-133 The thermal efficiency and power output of a gas turbine are given. The rate of fuel consumption of the gas turbine is to be determined.

Assumptions Steady operating conditions exist.

Properties The density and heating value of the fuel are given to be 0.8 g/cm^3 and $42,000 \text{ kJ/kg}$, respectively.

Analysis This gas turbine is converting 21% of the chemical energy released during the combustion process into work. The amount of energy input required to produce a power output of $6,000 \text{ kW}$ is determined from the definition of thermal efficiency to be

$$\dot{Q}_H = \frac{\dot{W}_{\text{net,out}}}{\eta_{\text{th}}} = \frac{6000 \text{ kJ/s}}{0.21} = 28,570 \text{ kJ/s}$$

To supply energy at this rate, the engine must burn fuel at a rate of

$$\dot{m} = \frac{28,570 \text{ kJ/s}}{42,000 \text{ kJ/kg}} = 0.6803 \text{ kg/s}$$

since $42,000 \text{ kJ}$ of thermal energy is released for each kg of fuel burned. Then the volume flow rate of the fuel becomes

$$\dot{V} = \frac{\dot{m}}{\rho} = \frac{0.6803 \text{ kg/s}}{0.8 \text{ kg/L}} = \mathbf{0.850 \text{ L/s}}$$

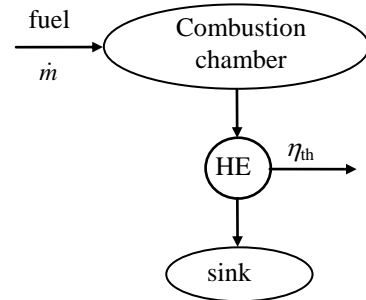

6-134 A performance of a refrigerator declines as the temperature of the refrigerated space decreases. The minimum amount of work needed to remove 1 kJ of heat from liquid helium at 3 K is to be determined.

Analysis The power input to a refrigerator will be a minimum when the refrigerator operates in a reversible manner. The coefficient of performance of a reversible refrigerator depends on the temperature limits in the cycle only, and is determined from

$$\text{COP}_{\text{R,rev}} = \frac{1}{(T_H/T_L) - 1} = \frac{1}{(300 \text{ K})/(3 \text{ K}) - 1} = 0.0101$$

The power input to this refrigerator is determined from the definition of the coefficient of performance of a refrigerator,

$$W_{\text{net,in,min}} = \frac{Q_R}{\text{COP}_{\text{R,max}}} = \frac{1 \text{ kJ}}{0.0101} = \mathbf{99 \text{ kJ}}$$

6-135 A Carnot heat pump cycle is executed in a steady-flow system with R-134a flowing at a specified rate. The net power input and the ratio of the maximum-to-minimum temperatures are given. The ratio of the maximum to minimum pressures is to be determined.

Analysis The coefficient of performance of the cycle is

$$\text{COP}_{\text{HP}} = \frac{1}{1 - T_L/T_H} = \frac{1}{1 - 1/1.2} = 6.0$$

and

$$\dot{Q}_H = \text{COP}_{\text{HP}} \times \dot{W}_{\text{in}} = (6.0)(5 \text{ kW}) = 30.0 \text{ kJ/s}$$

$$q_H = \frac{\dot{Q}_H}{\dot{m}} = \frac{30.0 \text{ kJ/s}}{0.22 \text{ kg/s}} = 136.36 \text{ kJ/kg} = h_{fg@T_H}$$

since the enthalpy of vaporization h_{fg} at a given T or P represents the amount of heat transfer per unit mass as a substance is converted from saturated liquid to saturated vapor at that T or P . Therefore, T_H is the temperature that corresponds to the h_{fg} value of 136.36 kJ/kg, and is determined from the R-134a tables to be

$$T_H \cong 62.0^\circ\text{C} = 335 \text{ K}$$

and

$$P_{\text{max}} = P_{\text{sat}@62.0^\circ\text{C}} = 1764 \text{ kPa}$$

$$T_L = \frac{T_H}{1.25} = \frac{335.1 \text{ K}}{1.2} = 291.4 \text{ K} \cong 18.3^\circ\text{C}$$

Also,

$$P_{\text{min}} = P_{\text{sat}@18.3^\circ\text{C}} = 542 \text{ kPa}$$

Then the ratio of the maximum to minimum pressures in the cycle is

$$\frac{P_{\text{max}}}{P_{\text{min}}} = \frac{1764 \text{ kPa}}{542 \text{ kPa}} = \mathbf{3.25}$$

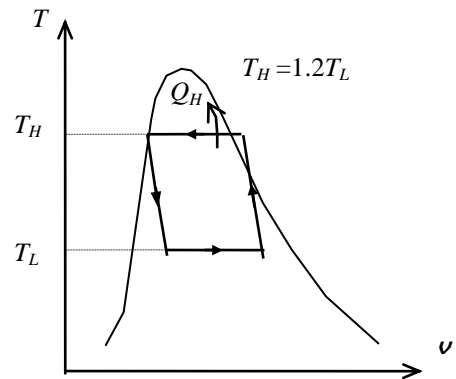

6-136 Switching to energy efficient lighting reduces the electricity consumed for lighting as well as the cooling load in summer, but increases the heating load in winter. It is to be determined if switching to efficient lighting will increase or decrease the total energy cost of a building.

Assumptions The light escaping through the windows is negligible so that the entire lighting energy becomes part of the internal heat generation.

Analysis (a) Efficient lighting reduces the amount of electrical energy used for lighting year-around as well as the amount of heat generation in the house since light is eventually converted to heat. As a result, the electrical energy needed to air condition the house is also reduced. Therefore, in summer, the total cost of energy use of the household definitely decreases.

(b) In winter, the heating system must make up for the reduction in the heat generation due to reduced energy used for lighting. The total cost of energy used in this case will still decrease if the cost of unit heat energy supplied by the heating system is less than the cost of unit energy provided by lighting.

The cost of 1 kWh heat supplied from lighting is \$0.12 since all the energy consumed by lamps is eventually converted to thermal energy. Noting that 1 therm = 105,500 kJ = 29.3 kWh and the furnace is 80% efficient, the cost of 1 kWh heat supplied by the heater is

$$\begin{aligned}\text{Cost of 1 kWh heat supplied by furnace} &= (\text{Amount of useful energy} / \eta_{\text{furnace}})(\text{Price}) \\ &= [(1 \text{ kWh}) / 0.80] (\$1.40 / \text{therm}) \left(\frac{1 \text{ therm}}{29.3 \text{ kWh}} \right) \\ &= \$0.060 \text{ (per kWh heat)}\end{aligned}$$



which is less than \$0.12. Thus we conclude that switching to energy efficient lighting will **reduce** the total energy cost of this building both in summer and in winter.

Discussion To determine the amount of cost savings due to switching to energy efficient lighting, consider 10 h of operation of lighting in summer and in winter for 1 kW rated power for lighting.

Current lighting:

Lighting cost: (Energy used)(Unit cost) = (1 kW)(10 h)(\$0.12/kWh) = \$1.20

Increase in air conditioning cost: (Heat from lighting/COP)(unit cost) = (10 kWh/3.5)(\$0.12/kWh) = \$0.34

Decrease in the heating cost = [Heat from lighting/Eff](unit cost) = (10/0.8 kWh)(\$1.40/29.3/kWh) = \$0.60

Total cost in summer = 1.20 + 0.34 = \$1.54 Total cost in winter = 1.20 - 0.60 = \$0.60.

Energy efficient lighting:

Lighting cost: (Energy used)(Unit cost) = (0.25 kW)(10 h)(\$0.12/kWh) = \$0.30

Increase in air conditioning cost: (Heat from lighting/COP)(unit cost) = (2.5 kWh/3.5)(\$0.12/kWh) = \$0.086

Decrease in the heating cost = [Heat from lighting/Eff](unit cost) = (2.5/0.8 kWh)(\$1.40/29.3/kWh) = \$0.15

Total cost in summer = 0.30 + 0.086 = \$0.39; Total cost in winter = \$0.30 - 0.15 = \$0.15.

Note that during a day with 10 h of operation, the total energy cost decreases from \$1.54 to \$0.39 in summer, and from \$0.60 to \$0.15 in winter when efficient lighting is used.

6-137 A heat pump is used to heat a house. The maximum money saved by using the lake water instead of outside air as the heat source is to be determined.

Assumptions 1 Steady operating conditions exist. **2** The kinetic and potential energy changes are zero.

Analysis When outside air is used as the heat source, the cost of energy is calculated considering a reversible heat pump as follows:

$$\text{COP}_{\max} = \frac{1}{1 - T_L / T_H} = \frac{1}{1 - (0 + 273) / (25 + 273)} = 11.92$$

$$\dot{W}_{\text{in, min}} = \frac{\dot{Q}_H}{\text{COP}_{\max}} = \frac{(140,000 / 3600) \text{ kW}}{11.92} = 3.262 \text{ kW}$$

$$\text{Cost}_{\text{air}} = (3.262 \text{ kW})(100 \text{ h})(\$0.105/\text{kWh}) = \$34.26$$

Repeating calculations for lake water,

$$\text{COP}_{\max} = \frac{1}{1 - T_L / T_H} = \frac{1}{1 - (10 + 273) / (25 + 273)} = 19.87$$

$$\dot{W}_{\text{in, min}} = \frac{\dot{Q}_H}{\text{COP}_{\max}} = \frac{(140,000 / 3600) \text{ kW}}{19.87} = 1.957 \text{ kW}$$

$$\text{Cost}_{\text{lake}} = (1.957 \text{ kW})(100 \text{ h})(\$0.105/\text{kWh}) = \$20.55$$

Then the money saved becomes

$$\text{Money Saved} = \text{Cost}_{\text{air}} - \text{Cost}_{\text{lake}} = \$34.26 - \$20.55 = \mathbf{\$13.7}$$

6-138 The cargo space of a refrigerated truck is to be cooled from 25°C to an average temperature of 5°C. The time it will take for an 11-kW refrigeration system to precool the truck is to be determined.

Assumptions 1 The ambient conditions remain constant during precooling. **2** The doors of the truck are tightly closed so that the infiltration heat gain is negligible. **3** The air inside is sufficiently dry so that the latent heat load on the refrigeration system is negligible. **4** Air is an ideal gas with constant specific heats.

Properties The density of air is taken 1.2 kg/m³, and its specific heat at the average temperature of 15°C is $c_p = 1.0 \text{ kJ/kg}\cdot^\circ\text{C}$ (Table A-2).

Analysis The mass of air in the truck is

$$m_{\text{air}} = \rho_{\text{air}} V_{\text{truck}} = (1.2 \text{ kg/m}^3)(12 \text{ m} \times 2.3 \text{ m} \times 3.5 \text{ m}) = 116 \text{ kg}$$

The amount of heat removed as the air is cooled from 25 to 5°C

$$\begin{aligned} Q_{\text{cooling air}} &= (mc_p \Delta T)_{\text{air}} = (116 \text{ kg})(1.0 \text{ kJ/kg}\cdot^\circ\text{C})(25 - 5)^\circ\text{C} \\ &= 2,320 \text{ kJ} \end{aligned}$$

Noting that UA is given to be 80 W/°C and the average air temperature in the truck during precooling is $(25+5)/2 = 15^\circ\text{C}$, the average rate of heat gain by transmission is determined to be

$$\dot{Q}_{\text{transmission, avg}} = UA\Delta T = (120 \text{ W}/^\circ\text{C})(25 - 15)^\circ\text{C} = 1200 \text{ W} = 1.2 \text{ kJ/s}$$

Therefore, the time required to cool the truck from 25 to 5°C is determined to be

$$\begin{aligned} \dot{Q}_{\text{refrig.}} \Delta t &= Q_{\text{cooling air}} + \dot{Q}_{\text{transmission}} \Delta t \\ \rightarrow \Delta t &= \frac{Q_{\text{cooling air}}}{\dot{Q}_{\text{refrig.}} - \dot{Q}_{\text{transmission}}} = \frac{2320 \text{ kJ}}{(11 - 1.2) \text{ kJ/s}} = 237 \text{ s} = \mathbf{3.95 \text{ min}} \end{aligned}$$

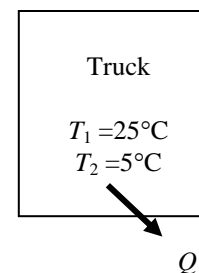

6-139 The maximum flow rate of a standard shower head can be reduced from 13.3 to 10.5 L/min by switching to low-flow shower heads. The amount of oil and money a family of four will save per year by replacing the standard shower heads by the low-flow ones are to be determined.

Assumptions **1** Steady operating conditions exist. **2** Showers operate at maximum flow conditions during the entire shower. **3** Each member of the household takes a 5-min shower every day.

Properties The specific heat of water is $c = 4.18 \text{ kJ/kg}\cdot^\circ\text{C}$ and heating value of heating oil is 146,300 kJ/gal (given). The density of water is $\rho = 1 \text{ kg/L}$.

Analysis The low-flow heads will save water at a rate of

$$\dot{V}_{\text{saved}} = [(13.3 - 10.5) \text{ L/min}](6 \text{ min/person}\cdot\text{day})(4 \text{ persons})(365 \text{ days/yr}) = 24,528 \text{ L/year}$$

$$\dot{m}_{\text{saved}} = \rho \dot{V}_{\text{saved}} = (1 \text{ kg/L})(24,528 \text{ L/year}) = 24,528 \text{ kg/year}$$

Then the energy, fuel, and money saved per year becomes

$$\text{Energy saved} = \dot{m}_{\text{saved}} c \Delta T = (24,528 \text{ kg/year})(4.18 \text{ kJ/kg}\cdot^\circ\text{C})(42 - 15)^\circ\text{C} = 2,768,000 \text{ kJ/year}$$

$$\text{Fuel saved} = \frac{\text{Energy saved}}{(\text{Efficiency})(\text{Heating value of fuel})} = \frac{2,768,000 \text{ kJ/year}}{(0.65)(146,300 \text{ kJ/gal})} = \mathbf{29.1 \text{ gal/year}}$$

$$\text{Money saved} = (\text{Fuel saved})(\text{Unit cost of fuel}) = (29.1 \text{ gal/year})(\$2.80/\text{gal}) = \mathbf{\$81.5/\text{year}}$$

Therefore, switching to low-flow shower heads will save about \$80 per year in energy costs.

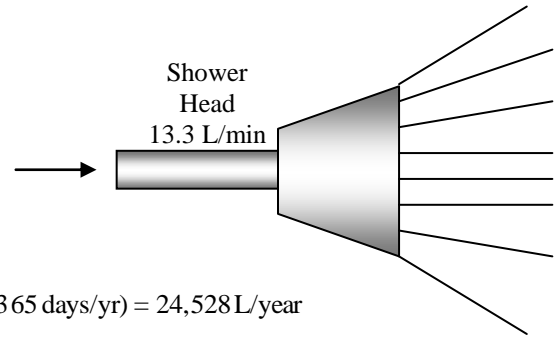



6-140 The maximum work that can be extracted from a pond containing 10^5 kg of water at 350 K when the temperature of the surroundings is 300 K is to be determined. Temperature intervals of (a) 5 K, (b) 2 K, and (c) 1 K until the pond temperature drops to 300 K are to be used.

Analysis The problem is solved using EES, and the solution is given below.

"Knowns:"

$$T_L = 300 \text{ [K]}$$

$$m_pond = 1E+5 \text{ [kg]}$$

$$C_pond = 4.18 \text{ [kJ/kg-K]} \text{ "Table A.3"}$$

$$T_H_high = 350 \text{ [K]}$$

$$T_H_low = 300 \text{ [K]}$$

$$\text{deltaT_H} = 1 \text{ [K]} \text{ "deltaT_H is the stepsize for the EES integral function."}$$

"The maximum work will be obtained if a Carnot heat pump is used. The sink temperature of this heat engine will remain constant at 300 K but the source temperature will be decreasing from 350 K to 300 K. Then the thermal efficiency of the Carnot heat engine operating between pond and the ambient air can be expressed as"

$$\text{eta_th_C} = 1 - T_L/T_H$$

"where TH is a variable. The conservation of energy relation for the pond can be written in the differential form as"

$$\text{deltaQ_pond} = m_pond * C_pond * \text{deltaT_H}$$

"Heat transferred to the heat engine:"

$$\text{deltaQ_H} = -\text{deltaQ_pond}$$

$$\text{IntegrandW_out} = \text{eta_th_C} * m_pond * C_pond$$

"Exact Solution by integration from $T_H = 350$ K to 300 K:"

$$W_out_exact = -m_pond * C_pond * (T_H_low - T_H_high - T_L * \ln(T_H_low/T_H_high))$$

"EES integral function where the stepsize is an input to the solution."

$$W_EES_1 = \text{integral}(\text{IntegrandW_out}, T_H, T_H_low, T_H_high, \text{deltaT_H})$$

$$W_EES_2 = \text{integral}(\text{IntegrandW_out}, T_H, T_H_low, T_H_high, 2 * \text{deltaT_H})$$

$$W_EES_5 = \text{integral}(\text{IntegrandW_out}, T_H, T_H_low, T_H_high, 5 * \text{deltaT_H})$$

SOLUTION

$$C_pond = 4.18 \text{ [kJ/kg-K]}$$

$$\text{deltaQ_H} = -418000 \text{ [kJ]}$$

$$\text{deltaQ_pond} = 418000 \text{ [kJ]}$$

$$\text{deltaT_H} = 1 \text{ [K]}$$

$$\text{eta_th_C} = 0.1429$$

$$\text{IntegrandW_out} = 59714 \text{ [kJ]}$$

$$m_pond = 100000 \text{ [kg]}$$

$$T_H = 350 \text{ [K]}$$

$$T_H_high = 350 \text{ [K]}$$

$$T_H_low = 300 \text{ [K]}$$

$$T_L = 300 \text{ [K]}$$

$$W_EES_1 = 1.569E+06 \text{ [kJ]}$$

$$W_EES_2 = 1.569E+06 \text{ [kJ]}$$

$$W_EES_5 = 1.569E+06 \text{ [kJ]}$$

$$W_out_exact = 1.570E+06 \text{ [kJ]}$$

This problem can also be solved exactly by integration as follows:

The maximum work will be obtained if a Carnot heat engine is used. The sink temperature of this heat engine will remain constant at 300 K but the source temperature will be decreasing from 350 K to 300 K. Then the thermal efficiency of the Carnot heat engine operating between pond and the ambient air can be expressed as

$$\eta_{\text{th,C}} = 1 - \frac{T_L}{T_H} = 1 - \frac{300}{T_H}$$

where T_H is a variable. The conservation of energy relation for the pond can be written in the differential form as

$$\partial Q_{\text{pond}} = mcdT_H$$

and

$$\partial Q_H = -\partial Q_{\text{pond}} = -mcdT_H = -(10^5 \text{ kg})(4.18 \text{ kJ/kg} \cdot \text{K})dT_H$$

Also,

$$\partial W_{\text{net}} = \eta_{\text{th,C}} \partial Q_H = -\left(1 - \frac{300}{T_H}\right)(10^5 \text{ kg})(4.18 \text{ kJ/kg} \cdot \text{K})\partial T_H$$

The total work output is obtained by integration,

$$\begin{aligned} W_{\text{net}} &= \int_{300}^{350} \eta_{\text{th,C}} \partial Q_H = \int_{300}^{350} \left(1 - \frac{300}{T_H}\right)(10^5 \text{ kg})(4.18 \text{ kJ/kg} \cdot \text{K})dT_H \\ &= 4.18 \times 10^5 \int_{300}^{350} \left(1 - \frac{300}{T_H}\right) dT_H = \mathbf{15.7 \times 10^5 \text{ kJ}} \end{aligned}$$

which is the exact result. The values obtained by computer solution will approach this value as the temperature interval is decreased.

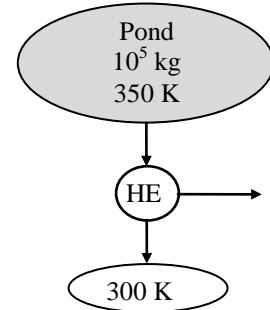

6-141 A refrigeration system is to cool bread loaves at a rate of 1200 per hour by refrigerated air at -30°C . The rate of heat removal from the breads, the required volume flow rate of air, and the size of the compressor of the refrigeration system are to be determined.

Assumptions 1 Steady operating conditions exist. 2 The thermal properties of the bread loaves are constant. 3 The cooling section is well-insulated so that heat gain through its walls is negligible.

Properties The average specific and latent heats of bread are given to be $2.93\text{ kJ/kg}\cdot^{\circ}\text{C}$ and 109.3 kJ/kg , respectively. The gas constant of air is $0.287\text{ kPa}\cdot\text{m}^3/\text{kg}\cdot\text{K}$ (Table A-1), and the specific heat of air at the average temperature of $(-30 + -22)/2 = -26^{\circ}\text{C} \approx 250\text{ K}$ is $c_p = 1.0\text{ kJ/kg}\cdot^{\circ}\text{C}$ (Table A-2).

Analysis (a) Noting that the breads are cooled at a rate of 500 loaves per hour, breads can be considered to flow steadily through the cooling section at a mass flow rate of

$$\dot{m}_{\text{bread}} = (1200\text{ breads/h})(0.350\text{ kg/bread}) = 420\text{ kg/h} = 0.1167\text{ kg/s}$$

Then the rate of heat removal from the breads as they are cooled from 30°C to -10°C and frozen becomes

$$\dot{Q}_{\text{bread}} = (\dot{m}c_p\Delta T)_{\text{bread}} = (420\text{ kg/h})(2.93\text{ kJ/kg}\cdot^{\circ}\text{C})(30 - (-10))^{\circ}\text{C} = 49,224\text{ kJ/h}$$

$$\dot{Q}_{\text{freezing}} = (\dot{m}h_{\text{latent}})_{\text{bread}} = (420\text{ kg/h})(109.3\text{ kJ/kg}) = 45,906\text{ kJ/h}$$

and

$$\dot{Q}_{\text{total}} = \dot{Q}_{\text{bread}} + \dot{Q}_{\text{freezing}} = 49,224 + 45,906 = \mathbf{95,130\text{ kJ/h}}$$

(b) All the heat released by the breads is absorbed by the refrigerated air, and the temperature rise of air is not to exceed 8°C . The minimum mass flow and volume flow rates of air are determined to be

$$\dot{m}_{\text{air}} = \frac{\dot{Q}_{\text{air}}}{(c_p\Delta T)_{\text{air}}} = \frac{95,130\text{ kJ/h}}{(1.0\text{ kJ/kg}\cdot^{\circ}\text{C})(8^{\circ}\text{C})} = 11,891\text{ kg/h}$$

$$\rho = \frac{P}{RT} = \frac{101.3\text{ kPa}}{(0.287\text{ kPa}\cdot\text{m}^3/\text{kg}\cdot\text{K})(-30 + 273)\text{ K}} = 1.453\text{ kg/m}^3$$

$$\dot{V}_{\text{air}} = \frac{\dot{m}_{\text{air}}}{\rho_{\text{air}}} = \frac{11,891\text{ kg/h}}{1.453\text{ kg/m}^3} = \mathbf{8185\text{ m}^3/\text{h}}$$

(c) For a COP of 1.2, the size of the compressor of the refrigeration system must be

$$\dot{W}_{\text{refrig}} = \frac{\dot{Q}_{\text{refrig}}}{\text{COP}} = \frac{95,130\text{ kJ/h}}{1.2} = 79,275\text{ kJ/h} = \mathbf{22.02\text{ kW}}$$

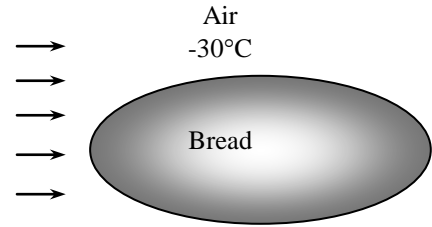

6-142 The drinking water needs of a production facility with 20 employees is to be met by a bubbler type water fountain. The size of compressor of the refrigeration system of this water cooler is to be determined.

Assumptions 1 Steady operating conditions exist. 2 Water is an incompressible substance with constant properties at room temperature. 3 The cold water requirement is 0.4 L/h per person.

Properties The density and specific heat of water at room temperature are $\rho = 1.0 \text{ kg/L}$ and $c = 4.18 \text{ kJ/kg}\cdot^\circ\text{C}$ (Table A-3).

Analysis The refrigeration load in this case consists of the heat gain of the reservoir and the cooling of the incoming water. The water fountain must be able to provide water at a rate of

$$\dot{m}_{\text{water}} = \rho \dot{V}_{\text{water}} = (1 \text{ kg/L})(0.4 \text{ L/h}\cdot\text{person})(20 \text{ persons}) = 8.0 \text{ kg/h}$$

To cool this water from 22°C to 8°C , heat must be removed from the water at a rate of

$$\begin{aligned} \dot{Q}_{\text{cooling}} &= \dot{m}c_p(T_{\text{in}} - T_{\text{out}}) \\ &= (8.0 \text{ kg/h})(4.18 \text{ kJ/kg}\cdot^\circ\text{C})(22 - 8)^\circ\text{C} \\ &= 468 \text{ kJ/h} = 130 \text{ W} \quad (\text{since } 1 \text{ W} = 3.6 \text{ kJ/h}) \end{aligned}$$

Then total refrigeration load becomes

$$\dot{Q}_{\text{refrig, total}} = \dot{Q}_{\text{cooling}} + \dot{Q}_{\text{transfer}} = 130 + 45 = 175 \text{ W}$$

Noting that the coefficient of performance of the refrigeration system is 2.9, the required power input is

$$\dot{W}_{\text{refrig}} = \frac{\dot{Q}_{\text{refrig}}}{\text{COP}} = \frac{175 \text{ W}}{2.9} = \mathbf{60.3 \text{ W}}$$

Therefore, the power rating of the compressor of this refrigeration system must be at least 60.3 W to meet the cold water requirements of this office.

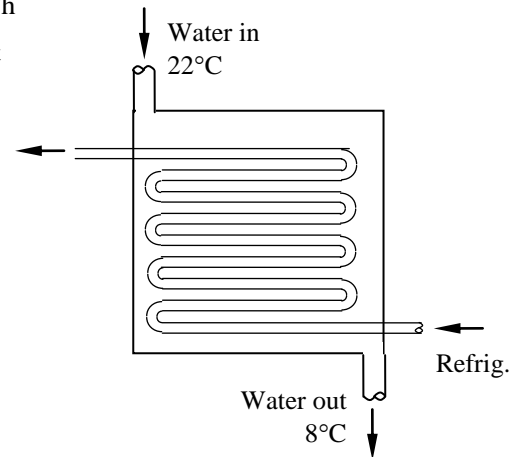

6-143  A typical heat pump powered water heater costs about \$800 more to install than a typical electric water heater. The number of years it will take for the heat pump water heater to pay for its cost differential from the energy it saves is to be determined.

Assumptions **1** The price of electricity remains constant. **2** Water is an incompressible substance with constant properties at room temperature. **3** Time value of money (interest, inflation) is not considered.

Analysis The amount of electricity used to heat the water and the net amount transferred to water are

$$\begin{aligned} \text{Total energy used (electrical)} &= \frac{\text{Total cost of energy}}{\text{Unit cost of energy}} \\ &= \frac{\$350/\text{year}}{\$0.11/\text{kWh}} \\ &= 3182 \text{ kWh/year} \end{aligned}$$

$$\begin{aligned} \text{Total energy transfer to water} &= \dot{E}_{\text{in}} = (\text{Efficiency})(\text{Total energy used}) \\ &= 0.95 \times 3182 \text{ kWh/year} \\ &= 3023 \text{ kWh/year} \end{aligned}$$

The amount of electricity consumed by the heat pump and its cost are

$$\text{Energy usage (of heat pump)} = \frac{\text{Energy transfer to water}}{\text{COP}_{\text{HP}}} = \frac{3023 \text{ kWh/year}}{3.3} = 916.0 \text{ kWh/year}$$

$$\begin{aligned} \text{Energy cost (of heat pump)} &= (\text{Energy usage})(\text{Unit cost of energy}) \\ &= (916.0 \text{ kWh/year})(\$0.11/\text{kWh}) \\ &= \$100.8/\text{year} \end{aligned}$$

Then the money saved per year by the heat pump and the simple payback period become

$$\begin{aligned} \text{Money saved} &= (\text{Energy cost of electric heater}) - (\text{Energy cost of heat pump}) \\ &= \$350 - \$100.8 \\ &= \$249.2 \end{aligned}$$

$$\text{Simple payback period} = \frac{\text{Additional installation cost}}{\text{Money saved}} = \frac{\$800}{\$249.2/\text{year}} = \mathbf{3.21 \text{ years}}$$

Discussion The economics of heat pump water heater will be even better if the air in the house is used as the heat source for the heat pump in summer, and thus also serving as an air-conditioner.

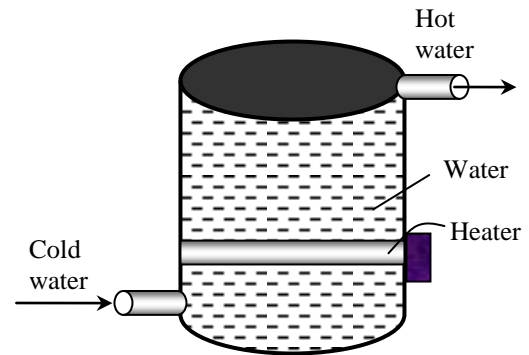



6-144 Problem 6-143 is reconsidered. The effect of the heat pump COP on the yearly operation costs and the number of years required to break even are to be considered.

Analysis The problem is solved using EES, and the results are tabulated and plotted below.

"Energy supplied by the water heater to the water per year is E_ElecHeater"

"Cost per year to operate electric water heater for one year is:"

$$\text{Cost_ElectHeater} = 350 \text{ [$/year]}$$

"Energy supplied to the water by electric heater is 90% of energy purchased"

$$\text{eta} = 0.95$$

$$\text{E_ElectHeater} = \text{eta} * \text{Cost_ElectHeater} / \text{UnitCost} \text{ "[kWh/year]"}$$

$$\text{UnitCost} = 0.11 \text{ [$/kWh]}$$

"For the same amount of heated water and assuming that all the heat energy leaving the heat pump goes into the water, then"

"Energy supplied by heat pump heater = Energy supplied by electric heater"

$$\text{E_HeatPump} = \text{E_ElectHeater} \text{ "[kWh/year]"}$$

"Electrical Work energy supplied to heat pump = Heat added to water/COP"

$$\text{COP} = 3.3$$

$$\text{W_HeatPump} = \text{E_HeatPump} / \text{COP} \text{ "[kWh/year]"}$$

"Cost per year to operate the heat pump is"

$$\text{Cost_HeatPump} = \text{W_HeatPump} * \text{UnitCost}$$

"Let N_BrkEven be the number of years to break even:"

"At the break even point, the total cost difference between the two water heaters is zero."

"Years to break even, neglecting the cost to borrow the extra \$800 to install heat pump"

$$\text{CostDiff_total} = 0 \text{ [\$]}$$

$$\text{CostDiff_total} = \text{AddCost} + \text{N_BrkEven} * (\text{Cost_HeatPump} - \text{Cost_ElectHeater}) \text{ "[\$]"}$$

$$\text{AddCost} = 800 \text{ [\$]}$$

COP	B _{BrkEven} [years]	Cost _{HeatPump} [\$/year]	Cost _{ElektHeater} [\$/year]
2	4.354	166.3	350
2.3	3.894	144.6	350
2.6	3.602	127.9	350
2.9	3.399	114.7	350
3.2	3.251	103.9	350
3.5	3.137	95	350
3.8	3.048	87.5	350
4.1	2.975	81.1	350
4.4	2.915	75.57	350
4.7	2.865	70.74	350
5	2.822	66.5	350

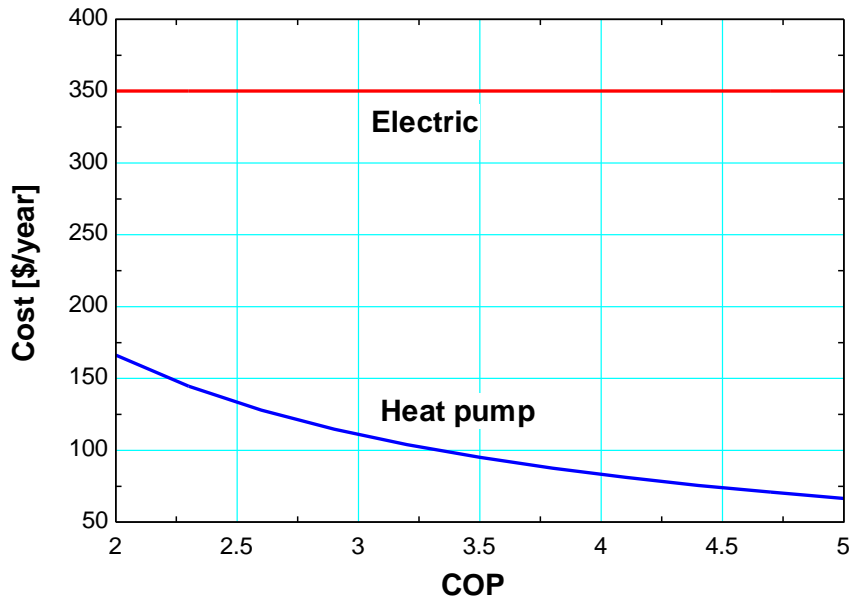
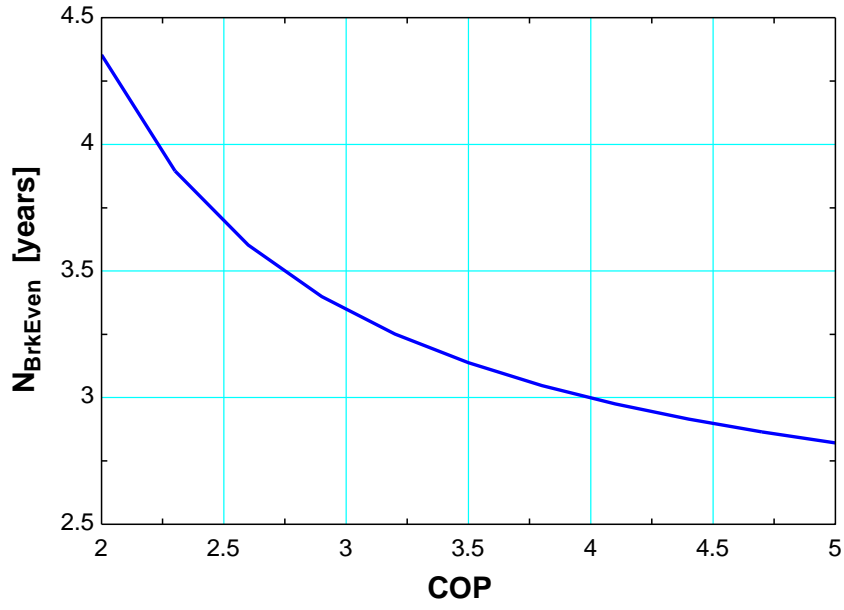

6-145 A home owner is to choose between a high-efficiency natural gas furnace and a ground-source heat pump. The system with the lower energy cost is to be determined.

Assumptions The two heaters are comparable in all aspects other than the cost of energy.

Analysis The unit cost of each kJ of useful energy supplied to the house by each system is

$$\text{Natural gas furnace:} \quad \text{Unit cost of useful energy} = \frac{(\$1.42/\text{therm})}{0.97} \left(\frac{1 \text{ therm}}{105,500 \text{ kJ}} \right) = \$13.9 \times 10^{-6} / \text{kJ}$$

$$\text{Heat Pump System:} \quad \text{Unit cost of useful energy} = \frac{(\$0.115/\text{kWh})}{3.5} \left(\frac{1 \text{ kWh}}{3600 \text{ kJ}} \right) = \$9.13 \times 10^{-6} / \text{kJ}$$

The energy cost of **ground-source heat pump system** will be lower.

6-146 A washing machine uses \$85/year worth of hot water heated by an electric water heater. The amount of hot water an average family uses per week is to be determined.

Assumptions 1 The electricity consumed by the motor of the washer is negligible. **2** Water is an incompressible substance with constant properties at room temperature.

Properties The density and specific heat of water at room temperature are $\rho = 1.0 \text{ kg/L}$ and $c = 4.18 \text{ kJ/kg}\cdot^\circ\text{C}$ (Table A-3).

Analysis The amount of electricity used to heat the water and the net amount transferred to water are

$$\text{Total energy used (electrical)} = \frac{\text{Total cost of energy}}{\text{Unit cost of energy}} = \frac{\$85/\text{year}}{\$0.113/\text{kWh}} = 752.2 \text{ kWh/year}$$

$$\begin{aligned} \text{Total energy transfer to water} &= \dot{E}_{\text{in}} = (\text{Efficiency})(\text{Total energy used}) = 0.91 \times 752.2 \text{ kWh/year} \\ &= 684.5 \text{ kWh/year} = (684.5 \text{ kWh/year}) \left(\frac{3600 \text{ kJ}}{1 \text{ kWh}} \right) \left(\frac{1 \text{ year}}{52 \text{ weeks}} \right) \\ &= 47,390 \text{ kJ/week} \end{aligned}$$

Then the mass and the volume of hot water used per week become

$$\dot{E}_{\text{in}} = \dot{m}c(T_{\text{out}} - T_{\text{in}}) \rightarrow \dot{m} = \frac{\dot{E}_{\text{in}}}{c(T_{\text{out}} - T_{\text{in}})} = \frac{47,390 \text{ kJ/week}}{(4.18 \text{ kJ/kg}\cdot^\circ\text{C})(55 - 12)^\circ\text{C}} = 263.7 \text{ kg/week}$$

and

$$\dot{V}_{\text{water}} = \frac{\dot{m}}{\rho} = \frac{263.7 \text{ kg/week}}{1 \text{ kg/L}} = \mathbf{264 \text{ L/week}}$$

Therefore, an average family uses 264 liters of hot water per week for washing clothes.

6-147 The ventilating fans of a house discharge a houseful of warmed air in one hour ($ACH = 1$). For an average outdoor temperature of 5°C during the heating season, the cost of energy “vented out” by the fans in 1 h is to be determined.

Assumptions **1** Steady operating conditions exist. **2** The house is maintained at 22°C and 92 kPa at all times. **3** The infiltrating air is heated to 22°C before it is vented out. **4** Air is an ideal gas with constant specific heats at room temperature. **5** The volume occupied by the people, furniture, etc. is negligible.

Properties The gas constant of air is $R = 0.287\text{ kPa}\cdot\text{m}^3/\text{kg}\cdot\text{K}$ (Table A-1). The specific heat of air at room temperature is $c_p = 1.0\text{ kJ}/\text{kg}\cdot^\circ\text{C}$ (Table A-2a).

Analysis The density of air at the indoor conditions of 92 kPa and 22°C is

$$\rho_o = \frac{P_o}{RT_o} = \frac{92\text{ kPa}}{(0.287\text{ kPa}\cdot\text{m}^3/\text{kg}\cdot\text{K})(22 + 273\text{ K})} = 1.087\text{ kg}/\text{m}^3$$

Noting that the interior volume of the house is $200 \times 2.8 = 560\text{ m}^3$, the mass flow rate of air vented out becomes

$$\dot{m}_{\text{air}} = \rho \dot{V}_{\text{air}} = (1.087\text{ kg}/\text{m}^3)(560\text{ m}^3/\text{h}) = 608.7\text{ kg}/\text{h} = 0.169\text{ kg}/\text{s}$$

Noting that the indoor air vented out at 22°C is replaced by infiltrating outdoor air at 5°C , this corresponds to energy loss at a rate of

$$\begin{aligned}\dot{Q}_{\text{loss, fan}} &= \dot{m}_{\text{air}} c_p (T_{\text{indoors}} - T_{\text{outdoors}}) \\ &= (0.169\text{ kg}/\text{s})(1.0\text{ kJ}/\text{kg}\cdot^\circ\text{C})(22 - 5)^\circ\text{C} = 2.874\text{ kJ}/\text{s} = 2.874\text{ kW}\end{aligned}$$

Then the amount and cost of the heat “vented out” per hour becomes

$$\text{Fuel energy loss} = \dot{Q}_{\text{loss, fan}} \Delta t / \eta_{\text{furnace}} = (2.874\text{ kW})(1\text{ h})/0.96 = 2.994\text{ kWh}$$

$$\text{Money loss} = (\text{Fuel energy loss})(\text{Unit cost of energy})$$

$$= (2.994\text{ kWh})(\$1.20/\text{therm}) \left(\frac{1\text{ therm}}{29.3\text{ kWh}} \right) = \mathbf{\$0.123}$$

Discussion Note that the energy and money loss associated with ventilating fans can be very significant. Therefore, ventilating fans should be used sparingly.

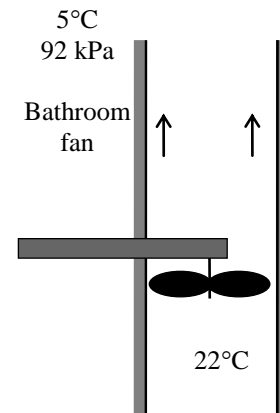

6-148 The ventilating fans of a house discharge a houseful of air-conditioned air in one hour ($ACH = 1$). For an average outdoor temperature of 28°C during the cooling season, the cost of energy “vented out” by the fans in 1 h is to be determined.

Assumptions **1** Steady operating conditions exist. **2** The house is maintained at 22°C and 92 kPa at all times. **3** The infiltrating air is cooled to 22°C before it is vented out. **4** Air is an ideal gas with constant specific heats at room temperature. **5** The volume occupied by the people, furniture, etc. is negligible. **6** Latent heat load is negligible.

Properties The gas constant of air is $R = 0.287 \text{ kPa}\cdot\text{m}^3/\text{kg}\cdot\text{K}$ (Table A-1). The specific heat of air at room temperature is $c_p = 1.0 \text{ kJ/kg}\cdot^\circ\text{C}$ (Table A-2a).

Analysis The density of air at the indoor conditions of 92 kPa and 22°C is

$$\rho_o = \frac{P_o}{RT_o} = \frac{92 \text{ kPa}}{(0.287 \text{ kPa}\cdot\text{m}^3/\text{kg}\cdot\text{K})(22 + 273 \text{ K})} = 1.087 \text{ kg/m}^3$$

Noting that the interior volume of the house is $200 \times 2.8 = 560 \text{ m}^3$, the mass flow rate of air vented out becomes

$$\dot{m}_{\text{air}} = \rho \dot{V}_{\text{air}} = (1.087 \text{ kg/m}^3)(560 \text{ m}^3/\text{h}) = 608.7 \text{ kg/h} = 0.1690 \text{ kg/s}$$

Noting that the indoor air vented out at 22°C is replaced by infiltrating outdoor air at 33°C , this corresponds to energy loss at a rate of

$$\begin{aligned} \dot{Q}_{\text{loss, fan}} &= \dot{m}_{\text{air}} c_p (T_{\text{outdoors}} - T_{\text{indoors}}) \\ &= (0.1690 \text{ kg/s})(1.0 \text{ kJ/kg}\cdot^\circ\text{C})(33 - 22)^\circ\text{C} = 1.859 \text{ kJ/s} = 1.859 \text{ kW} \end{aligned}$$

Then the amount and cost of the electric energy “vented out” per hour becomes

$$\begin{aligned} \text{Electric energy loss} &= \dot{Q}_{\text{loss, fan}} \Delta t / COP = (1.859 \text{ kW})(1 \text{ h})/2.1 = 0.8854 \text{ kWh} \\ \text{Money loss} &= (\text{Fuel energy loss})(\text{Unit cost of energy}) \\ &= (0.8854 \text{ kWh})(\$0.12/\text{kWh}) = \mathbf{\$0.106} \end{aligned}$$

Discussion Note that the energy and money loss associated with ventilating fans can be very significant. Therefore, ventilating fans should be used sparingly.

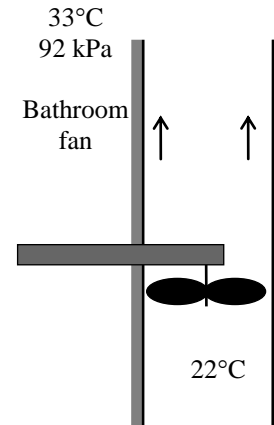

6-149 A geothermal heat pump with R-134a as the working fluid is considered. The evaporator inlet and exit states are specified. The mass flow rate of the refrigerant, the heating load, the COP, and the minimum power input to the compressor are to be determined.

Assumptions 1 The heat pump operates steadily. 2 The kinetic and potential energy changes are zero. 3 Steam properties are used for geothermal water.

Properties The properties of R-134a and water are (Steam and R-134a tables)

$$\left. \begin{array}{l} T_1 = 12^\circ\text{C} \\ x_1 = 0.15 \end{array} \right\} \left. \begin{array}{l} h_1 = 96.54 \text{ kJ/kg} \\ P_1 = 443.3 \text{ kPa} \end{array} \right\} h_2 = 257.33 \text{ kJ/kg}$$

$$\left. \begin{array}{l} P_2 = P_1 = 443.3 \text{ kPa} \\ x_2 = 1 \end{array} \right\}$$

$$\left. \begin{array}{l} T_{w,1} = 60^\circ\text{C} \\ x_{w,1} = 0 \end{array} \right\} h_{w,1} = 251.18 \text{ kJ/kg}$$

$$\left. \begin{array}{l} T_{w,2} = 40^\circ\text{C} \\ x_{w,2} = 0 \end{array} \right\} h_{w,2} = 167.53 \text{ kJ/kg}$$

Analysis (a) The rate of heat transferred from the water is the energy change of the water from inlet to exit

$$\dot{Q}_L = \dot{m}_w (h_{w,1} - h_{w,2}) = (0.065 \text{ kg/s})(251.18 - 167.53) \text{ kJ/kg} = 5.437 \text{ kW}$$

The energy increase of the refrigerant is equal to the energy decrease of the water in the evaporator. That is,

$$\dot{Q}_L = \dot{m}_R (h_2 - h_1) \longrightarrow \dot{m}_R = \frac{\dot{Q}_L}{h_2 - h_1} = \frac{5.437 \text{ kW}}{(257.33 - 96.54) \text{ kJ/kg}} = \mathbf{0.0338 \text{ kg/s}}$$

(b) The heating load is

$$\dot{Q}_H = \dot{Q}_L + \dot{W}_{\text{in}} = 5.437 + 1.6 = \mathbf{7.04 \text{ kW}}$$

(c) The COP of the heat pump is determined from its definition,

$$\text{COP} = \frac{\dot{Q}_H}{\dot{W}_{\text{in}}} = \frac{7.04 \text{ kW}}{1.6 \text{ kW}} = \mathbf{4.40}$$

(d) The COP of a reversible heat pump operating between the same temperature limits is

$$\text{COP}_{\text{max}} = \frac{1}{1 - T_L / T_H} = \frac{1}{1 - (25 + 273) / (60 + 273)} = 9.51$$

Then, the minimum power input to the compressor for the same refrigeration load would be

$$\dot{W}_{\text{in,min}} = \frac{\dot{Q}_H}{\text{COP}_{\text{max}}} = \frac{7.04 \text{ kW}}{9.51} = \mathbf{0.740 \text{ kW}}$$

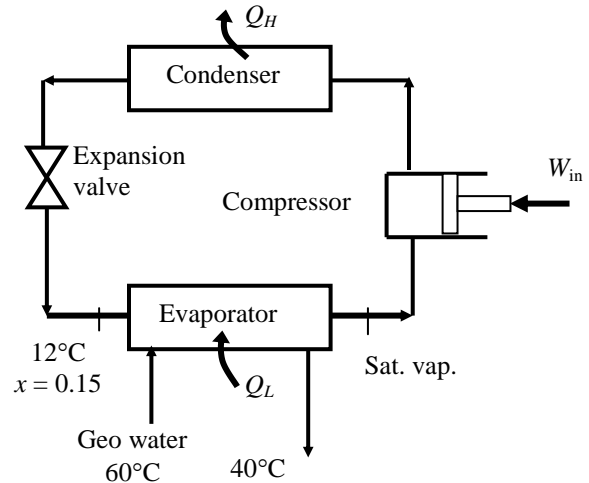

6-150 A heat pump is used as the heat source for a water heater. The rate of heat supplied to the water and the minimum power supplied to the heat pump are to be determined.

Assumptions 1 Steady operating conditions exist. 2 The kinetic and potential energy changes are zero.

Properties The specific heat and specific volume of water at room temperature are $c_p = 4.18 \text{ kJ/kg}\cdot\text{K}$ and $\nu = 0.001 \text{ m}^3/\text{kg}$ (Table A-3).

Analysis (a) An energy balance on the water heater gives the rate of heat supplied to the water

$$\begin{aligned}\dot{Q}_H &= \dot{m}c_p(T_2 - T_1) \\ &= \frac{\dot{V}}{\nu}c_p(T_2 - T_1) \\ &= \frac{(0.02/60) \text{ m}^3/\text{s}}{0.001 \text{ m}^3/\text{kg}}(4.18 \text{ kJ/kg}\cdot\text{C})(50 - 10) \text{ C} \\ &= \mathbf{55.73 \text{ kW}}\end{aligned}$$

(b) The COP of a reversible heat pump operating between the specified temperature limits is

$$\text{COP}_{\max} = \frac{1}{1 - T_L/T_H} = \frac{1}{1 - (0 + 273)/(30 + 273)} = 10.1$$

Then, the minimum power input would be

$$\dot{W}_{\text{in},\text{min}} = \frac{\dot{Q}_H}{\text{COP}_{\max}} = \frac{55.73 \text{ kW}}{10.1} = \mathbf{5.52 \text{ kW}}$$

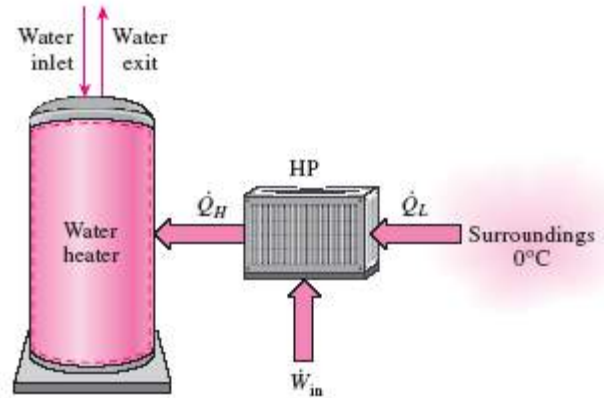

6-151 A heat pump receiving heat from a lake is used to heat a house. The minimum power supplied to the heat pump and the mass flow rate of lake water are to be determined.

Assumptions 1 Steady operating conditions exist. 2 The kinetic and potential energy changes are zero.

Properties The specific heat of water at room temperature is $c_p = 4.18 \text{ kJ/kg}\cdot\text{K}$ (Table A-3).

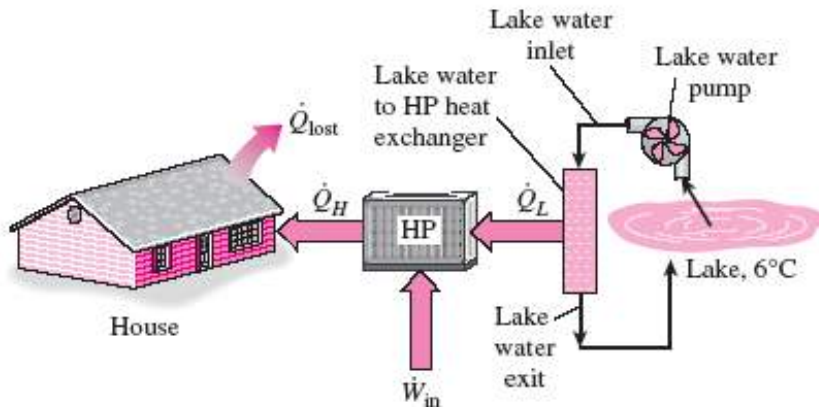

Analysis (a) The COP of a reversible heat pump operating between the specified temperature limits is

$$\text{COP}_{\max} = \frac{1}{1 - T_L / T_H} = \frac{1}{1 - (6 + 273) / (23 + 273)} = 17.41$$

Then, the minimum power input would be

$$\dot{W}_{\text{in},\min} = \frac{\dot{Q}_H}{\text{COP}_{\max}} = \frac{(52,000 / 3600) \text{ kW}}{17.41} = \frac{14.44 \text{ kW}}{17.41} = \mathbf{0.830 \text{ kW}}$$

(b) The rate of heat absorbed from the lake is

$$\dot{Q}_L = \dot{Q}_H - \dot{W}_{\text{in},\min} = 14.44 - 0.830 = 13.61 \text{ kW}$$

An energy balance on the heat exchanger gives the mass flow rate of lake water

$$\dot{m}_{\text{water}} = \frac{\dot{Q}_L}{c_p \Delta T} = \frac{13.61 \text{ kJ/s}}{(4.18 \text{ kJ/kg}\cdot\text{°C})(5 \text{ °C})} = \mathbf{0.651 \text{ kg/s}}$$

6-152 It is to be proven that the COP of all completely reversible refrigerators must be the same when the reservoir temperatures are the same.

Assumptions The refrigerators operate steadily.

Analysis We begin by assuming that $\text{COP}_A < \text{COP}_B$. When this is the case, a rearrangement of the coefficient of performance expression yields

$$W_A = \frac{Q_L}{\text{COP}_A} > \frac{Q_L}{\text{COP}_B} = W_B$$

That is, the magnitude of the work required to drive refrigerator A is greater than that needed to drive refrigerator B. Applying the first law to both refrigerators yields

$$Q_{H,A} > Q_{H,B}$$

since the work supplied to refrigerator A is greater than that supplied to refrigerator B, and both have the same cooling effect, Q_L .

Since A is a completely reversible refrigerator, we can reverse it without changing the magnitude of the heat and work transfers. This is illustrated in the figure below. The heat, Q_L , which is rejected by the reversed refrigerator A can now be routed directly to refrigerator B. The net effect when this is done is that no heat is exchanged with the T_L reservoir. The magnitude of the heat supplied to the reversed refrigerator A, $Q_{H,A}$ has been shown to be larger than that rejected by refrigerator B. There is then a net heat transfer from the T_H reservoir to the combined device in the dashed lines of the figure whose magnitude is given by $Q_{H,A} - Q_{H,B}$. Similarly, there is a net work production by the combined device whose magnitude is given by $W_A - W_B$.

The combined cyclic device then exchanges heat with a reservoir at a single temperature and produces work which is clearly a violation of the Kelvin-Planck statement of the second law. Our assumption the $\text{COP}_A < \text{COP}_B$ must then be wrong.

If we interchange A and B in the previous argument, we would conclude that the COP_B cannot be less than COP_A . The only alternative left is that

$$\text{COP}_A = \text{COP}_B$$

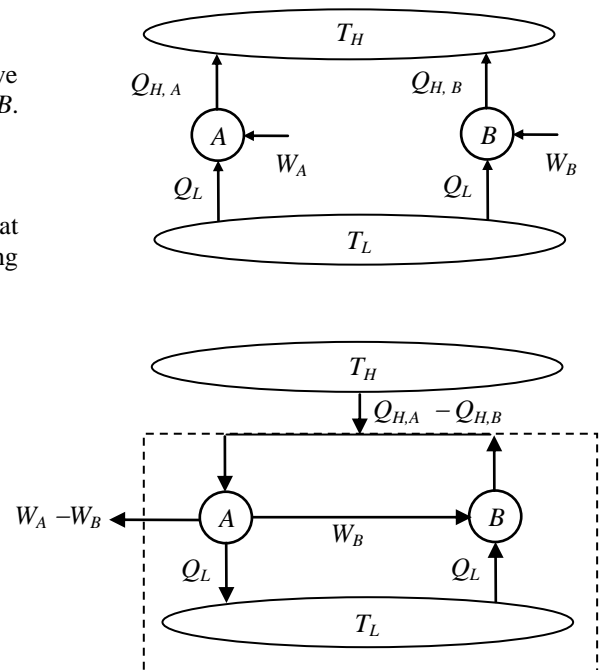

6-153 A Carnot heat engine is operating between specified temperature limits. The source temperature that will double the efficiency is to be determined.

Analysis Denoting the new source temperature by T_H^* , the thermal efficiency of the Carnot heat engine for both cases can be expressed as

$$\eta_{\text{th,C}} = 1 - \frac{T_L}{T_H} \quad \text{and} \quad \eta_{\text{th,C}}^* = 1 - \frac{T_L}{T_H^*} = 2\eta_{\text{th,C}}$$

Substituting,

$$1 - \frac{T_L}{T_H^*} = 2 \left(1 - \frac{T_L}{T_H} \right)$$

Solving for T_H^* ,

$$T_H^* = \frac{T_H T_L}{T_H - 2T_L}$$

which is the desired relation.

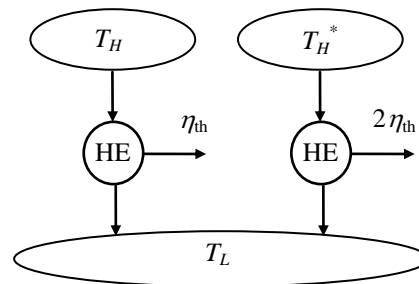

6-154 A Carnot cycle is analyzed for the case of temperature differences in the boiler and condenser. The ratio of overall temperatures for which the power output will be maximum, and an expression for the maximum net power output are to be determined.

Analysis It is given that

$$\dot{Q}_H = (hA)_H (T_H - T_H^*)$$

Therefore,

$$\dot{W} = \eta_{th} \dot{Q}_H = \left(1 - \frac{T_L^*}{T_H^*}\right) (hA)_H (T_H - T_H^*) = \left(1 - \frac{T_L^*}{T_H^*}\right) (hA)_H \left(1 - \frac{T_H^*}{T_H}\right) T_H$$

or,

$$\frac{\dot{W}}{(hA)_H T_H} = \left(1 - \frac{T_L^*}{T_H^*}\right) \left(1 - \frac{T_H^*}{T_H}\right) = (1-r)x \quad (1)$$

where we defined r and x as $r = T_L^*/T_H^*$ and $x = 1 - T_H^*/T_H$.

For a reversible cycle we also have

$$\frac{T_H^*}{T_L^*} = \frac{\dot{Q}_H}{\dot{Q}_L} \longrightarrow \frac{1}{r} = \frac{(hA)_H (T_H - T_H^*)}{(hA)_L (T_L^* - T_L)} = \frac{(hA)_H T_H (1 - T_H^*/T_H)}{(hA)_L T_H (T_L^*/T_H - T_L/T_H)}$$

but

$$\frac{T_L^*}{T_H} = \frac{T_L^*}{T_H^*} \frac{T_H^*}{T_H} = r(1-x)$$

Substituting into above relation yields

$$\frac{1}{r} = \frac{(hA)_H x}{(hA)_L [r(1-x) - T_L/T_H]}$$

Solving for x ,

$$x = \frac{r - T_L/T_H}{r[(hA)_H/(hA)_L + 1]} \quad (2)$$

Substitute (2) into (1):

$$\dot{W} = (hA)_H T_H (1-r) \frac{r - T_L/T_H}{r[(hA)_H/(hA)_L + 1]} \quad (3)$$

Taking the partial derivative $\frac{\partial \dot{W}}{\partial r}$ holding everything else constant and setting it equal to zero gives

$$r = \frac{T_L^*}{T_H} = \left(\frac{T_L}{T_H}\right)^{1/2} \quad (4)$$

which is the desired relation. The maximum net power output in this case is determined by substituting (4) into (3). It simplifies to

$$\dot{W}_{\max} = \frac{(hA)_H T_H}{1 + (hA)_H/(hA)_L} \left\{1 - \left(\frac{T_L}{T_H}\right)^{1/2}\right\}^2$$

6-155 It is to be shown that $\text{COP}_{HP} = \text{COP}_R + 1$ for the same temperature and heat transfer terms.

Analysis Using the definitions of COPs, the desired relation is obtained to be

$$\text{COP}_{HP} = \frac{Q_H}{W_{\text{net,in}}} = \frac{Q_L + W_{\text{net,in}}}{W_{\text{net,in}}} = \frac{Q_L}{W_{\text{net,in}}} + 1 = \text{COP}_R + 1$$

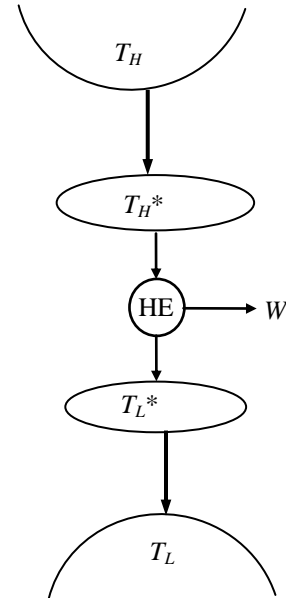

Fundamentals of Engineering (FE) Exam Problems

6-156 A 2.4-m high 200-m² house is maintained at 22°C by an air-conditioning system whose COP is 3.2. It is estimated that the kitchen, bath, and other ventilating fans of the house discharge a houseful of conditioned air once every hour. If the average outdoor temperature is 32°C, the density of air is 1.20 kg/m³, and the unit cost of electricity is \$0.10/kWh, the amount of money “vented out” by the fans in 10 hours is

- (a) \$0.50 (b) \$1.60 (c) \$5.00 (d) \$11.00 (e) \$16.00

Answer (a) \$0.50

Solution Solved by EES Software. Solutions can be verified by copying-and-pasting the following lines on a blank EES screen. (Similar problems and their solutions can be obtained easily by modifying numerical values).

```
COP=3.2
T1=22 "C"
T2=32 "C"
Price=0.10 "$/kWh"
Cp=1.005 "kJ/kg-C"
rho=1.20 "kg/m^3"
V=2.4*200 "m^3"
m=rho*V
m_total=m*10
Ein=m_total*Cp*(T2-T1)/COP "kJ"
Cost=(Ein/3600)*Price
```

"Some Wrong Solutions with Common Mistakes:"

```
W1_Cost=(Price/3600)*m_total*Cp*(T2-T1)*COP "Multiplying by Eff instead of dividing"
W2_Cost=(Price/3600)*m_total*Cp*(T2-T1) "Ignoring efficiency"
W3_Cost=(Price/3600)*m*Cp*(T2-T1)/COP "Using m instead of m_total"
W4_Cost=(Price/3600)*m_total*Cp*(T2+T1)/COP "Adding temperatures"
```

6-157 The drinking water needs of an office are met by cooling tap water in a refrigerated water fountain from 23°C to 6°C at an average rate of 10 kg/h. If the COP of this refrigerator is 3.1, the required power input to this refrigerator is

- (a) 197 W (b) 612 W (c) 64 W (d) 109 W (e) 403 W

Answer (c) 64 W

Solution Solved by EES Software. Solutions can be verified by copying-and-pasting the following lines on a blank EES screen. (Similar problems and their solutions can be obtained easily by modifying numerical values).

```
COP=3.1
Cp=4.18 "kJ/kg-C"
T1=23 "C"
T2=6 "C"
m_dot=10/3600 "kg/s"
Q_L=m_dot*Cp*(T1-T2) "kW"
W_in=Q_L*1000/COP "W"
```

"Some Wrong Solutions with Common Mistakes:"

```
W1_Win=m_dot*Cp*(T1-T2) *1000*COP "Multiplying by COP instead of dividing"
W2_Win=m_dot*Cp*(T1-T2) *1000 "Not using COP"
W3_Win=m_dot*(T1-T2) *1000/COP "Not using specific heat"
W4_Win=m_dot*Cp*(T1+T2) *1000/COP "Adding temperatures"
```

6-158 The label on a washing machine indicates that the washer will use \$85 worth of hot water if the water is heated by a 90% efficiency electric heater at an electricity rate of \$0.09/kWh. If the water is heated from 18°C to 45°C, the amount of hot water an average family uses per year, in metric tons, is

- (a) 11.6 tons (b) 15.8 tons (c) 27.1 tons (d) 30.1 tons (e) 33.5 tons

Answer (b) 27.1 tons

Solution Solved by EES Software. Solutions can be verified by copying-and-pasting the following lines on a blank EES screen. (Similar problems and their solutions can be obtained easily by modifying numerical values).

```
Eff=0.90
C=4.18 "kJ/kg-C"
T1=18 "C"
T2=45 "C"
Cost=85 "$"
Price=0.09 "$/kWh"
Ein=(Cost/Price)*3600 "kJ"
Ein=m*C*(T2-T1)/Eff "kJ"
```

"Some Wrong Solutions with Common Mistakes:"

```
Ein=W1_m*C*(T2-T1)*Eff "Multiplying by Eff instead of dividing"
Ein=W2_m*C*(T2-T1) "Ignoring efficiency"
Ein=W3_m*(T2-T1)/Eff "Not using specific heat"
Ein=W4_m*C*(T2+T1)/Eff "Adding temperatures"
```

6-159 A heat pump is absorbing heat from the cold outdoors at 5°C and supplying heat to a house at 25°C at a rate of 18,000 kJ/h. If the power consumed by the heat pump is 1.9 kW, the coefficient of performance of the heat pump is

- (a) 1.3 (b) 2.6 (c) 3.0 (d) 3.8 (e) 13.9

Answer (b) 2.6

Solution Solved by EES Software. Solutions can be verified by copying-and-pasting the following lines on a blank EES screen. (Similar problems and their solutions can be obtained easily by modifying numerical values).

```
TL=5 "C"
TH=25 "C"
QH=18000/3600 "kJ/s"
Win=1.9 "kW"
COP=QH/Win
```

"Some Wrong Solutions with Common Mistakes:"

```
W1_COP=Win/QH "Doing it backwards"
W2_COP=TH/(TH-TL) "Using temperatures in C"
W3_COP=(TH+273)/(TH-TL) "Using temperatures in K"
W4_COP=(TL+273)/(TH-TL) "Finding COP of refrigerator using temperatures in K"
```

6-160 A heat engine cycle is executed with steam in the saturation dome. The pressure of steam is 1 MPa during heat addition, and 0.4 MPa during heat rejection. The highest possible efficiency of this heat engine is

- (a) 8.0% (b) 15.6% (c) 20.2% (d) 79.8% (e) 100%

Answer (a) 8.0%

Solution Solved by EES Software. Solutions can be verified by copying-and-pasting the following lines on a blank EES screen. (Similar problems and their solutions can be obtained easily by modifying numerical values).

```
PH=1000 "kPa"
PL=400 "kPa"
TH=TEMPERATURE(Steam_IAPWS,x=0,P=PH)
TL=TEMPERATURE(Steam_IAPWS,x=0,P=PL)
Eta_Carnot=1-(TL+273)/(TH+273)
```

"Some Wrong Solutions with Common Mistakes:"

```
W1_Eta_Carnot=1-PL/PH "Using pressures"
W2_Eta_Carnot=1-TL/TH "Using temperatures in C"
W3_Eta_Carnot=TL/TH "Using temperatures ratio"
```

6-161 A heat engine receives heat from a source at 1000°C and rejects the waste heat to a sink at 50°C. If heat is supplied to this engine at a rate of 100 kJ/s, the maximum power this heat engine can produce is

- (a) 25.4 kW (b) 55.4 kW (c) 74.6 kW (d) 95.0 kW (e) 100.0 kW

Answer (c) 74.6 kW

Solution Solved by EES Software. Solutions can be verified by copying-and-pasting the following lines on a blank EES screen. (Similar problems and their solutions can be obtained easily by modifying numerical values).

```
TH=1000 "C"
TL=50 "C"
Q_in=100 "kW"
Eta=1-(TL+273)/(TH+273)
W_out=Eta*Q_in
```

"Some Wrong Solutions with Common Mistakes:"

```
W1_W_out=(1-TL/TH)*Q_in "Using temperatures in C"
W2_W_out=Q_in "Setting work equal to heat input"
W3_W_out=Q_in/Eta "Dividing by efficiency instead of multiplying"
W4_W_out=(TL+273)/(TH+273)*Q_in "Using temperature ratio"
```

6-162 A heat pump cycle is executed with R-134a under the saturation dome between the pressure limits of 1.4 MPa and 0.16 MPa. The maximum coefficient of performance of this heat pump is

- (a) 1.1 (b) 3.8 (c) 4.8 (d) 5.3 (e) 2.9

Answer (c) 4.8

Solution Solved by EES Software. Solutions can be verified by copying-and-pasting the following lines on a blank EES screen. (Similar problems and their solutions can be obtained easily by modifying numerical values).

```
PH=1400 "kPa"
PL=160 "kPa"
TH=TEMPERATURE(R134a,x=0,P=PH) "C"
TL=TEMPERATURE(R134a,x=0,P=PL) "C"
COP_HP=(TH+273)/(TH-TL)
```

"Some Wrong Solutions with Common Mistakes:"

```
W1_COP=PH/(PH-PL) "Using pressures"
W2_COP=TH/(TH-TL) "Using temperatures in C"
W3_COP=TL/(TH-TL) "Refrigeration COP using temperatures in C"
W4_COP=(TL+273)/(TH-TL) "Refrigeration COP using temperatures in K"
```

6-163 A refrigeration cycle is executed with R-134a under the saturation dome between the pressure limits of 1.6 MPa and 0.2 MPa. If the power consumption of the refrigerator is 3 kW, the maximum rate of heat removal from the cooled space of this refrigerator is

- (a) 0.45 kJ/s (b) 0.78 kJ/s (c) 3.0 kJ/s (d) 11.6 kJ/s (e) 14.6 kJ/s

Answer (d) 11.6 kJ/s

Solution Solved by EES Software. Solutions can be verified by copying-and-pasting the following lines on a blank EES screen. (Similar problems and their solutions can be obtained easily by modifying numerical values).

```
PH=1600 "kPa"
PL=200 "kPa"
W_in=3 "kW"
TH=TEMPERATURE(R134a,x=0,P=PH) "C"
TL=TEMPERATURE(R134a,x=0,P=PL) "C"
COP=(TL+273)/(TH-TL)
QL=W_in*COP "kW"
```

"Some Wrong Solutions with Common Mistakes:"

```
W1_QL=W_in*TL/(TH-TL) "Using temperatures in C"
W2_QL=W_in "Setting heat removal equal to power input"
W3_QL=W_in/COP "Dividing by COP instead of multiplying"
W4_QL=W_in*(TH+273)/(TH-TL) "Using COP definition for Heat pump"
```

6-164 A heat pump with a COP of 3.2 is used to heat a perfectly sealed house (no air leaks). The entire mass within the house (air, furniture, etc.) is equivalent to 1200 kg of air. When running, the heat pump consumes electric power at a rate of 5 kW. The temperature of the house was 7°C when the heat pump was turned on. If heat transfer through the envelope of the house (walls, roof, etc.) is negligible, the length of time the heat pump must run to raise the temperature of the entire contents of the house to 22°C is

- (a) 13.5 min (b) 43.1 min (c) 138 min (d) 18.8 min (e) 808 min

Answer (a) 13.5 min

Solution Solved by EES Software. Solutions can be verified by copying-and-pasting the following lines on a blank EES screen. (Similar problems and their solutions can be obtained easily by modifying numerical values).

```
COP=3.2
Cv=0.718 "kJ/kg.C"
m=1200 "kg"
T1=7 "C"
T2=22 "C"
QH=m*Cv*(T2-T1)
Win=5 "kW"
Win*time=QH/COP/60
```

"Some Wrong Solutions with Common Mistakes:"

```
Win*W1_time*60=m*Cv*(T2-T1) *COP "Multiplying by COP instead of dividing"
Win*W2_time*60=m*Cv*(T2-T1) "Ignoring COP"
Win*W3_time=m*Cv*(T2-T1) /COP "Finding time in seconds instead of minutes"
Win*W4_time*60=m*Cp*(T2-T1) /COP "Using Cp instead of Cv"
Cp=1.005 "kJ/kg.K"
```

6-165 A heat engine cycle is executed with steam in the saturation dome between the pressure limits of 7 MPa and 2 MPa. If heat is supplied to the heat engine at a rate of 150 kJ/s, the maximum power output of this heat engine is

- (a) 8.1 kW (b) 19.7 kW (c) 38.6 kW (d) 107 kW (e) 130 kW

Answer (b) 19.7 kW

Solution Solved by EES Software. Solutions can be verified by copying-and-pasting the following lines on a blank EES screen. (Similar problems and their solutions can be obtained easily by modifying numerical values).

```
PH=7000 "kPa"
PL=2000 "kPa"
Q_in=150 "kW"
TH=TEMPERATURE(Steam_IAPWS,x=0,P=PH) "C"
TL=TEMPERATURE(Steam_IAPWS,x=0,P=PL) "C"
Eta=1-(TL+273)/(TH+273)
W_out=Eta*Q_in
```

"Some Wrong Solutions with Common Mistakes:"

```
W1_W_out=(1-TL/TH)*Q_in "Using temperatures in C"
W2_W_out=(1-PL/PH)*Q_in "Using pressures"
W3_W_out=Q_in/Eta "Dividing by efficiency instead of multiplying"
W4_W_out=(TL+273)/(TH+273)*Q_in "Using temperature ratio"
```

6-166 An air-conditioning system operating on the reversed Carnot cycle is required to remove heat from the house at a rate of 32 kJ/s to maintain its temperature constant at 20°C. If the temperature of the outdoors is 35°C, the power required to operate this air-conditioning system is

- (a) 0.58 kW (b) 3.20 kW (c) 1.56 kW (d) 2.26 kW (e) 1.64 kW

Answer (e) 1.64 kW

Solution Solved by EES Software. Solutions can be verified by copying-and-pasting the following lines on a blank EES screen. (Similar problems and their solutions can be obtained easily by modifying numerical values).

```
TL=20 "C"
TH=35 "C"
QL=32 "kJ/s"
COP=(TL+273)/(TH-TL)
COP=QL/Win
```

"Some Wrong Solutions with Common Mistakes:"

```
QL=W1_Win*TL/(TH-TL) "Using temperatures in C"
QL=W2_Win "Setting work equal to heat input"
QL=W3_Win/COP "Dividing by COP instead of multiplying"
QL=W4_Win*(TH+273)/(TH-TL) "Using COP of HP"
```

6-167 A refrigerator is removing heat from a cold medium at 3°C at a rate of 7200 kJ/h and rejecting the waste heat to a medium at 30°C. If the coefficient of performance of the refrigerator is 2, the power consumed by the refrigerator is

- (a) 0.1 kW (b) 0.5 kW (c) 1.0 kW (d) 2.0 kW (e) 5.0 kW

Answer (c) 1.0 kW

Solution Solved by EES Software. Solutions can be verified by copying-and-pasting the following lines on a blank EES screen. (Similar problems and their solutions can be obtained easily by modifying numerical values).

```
TL=3 "C"
TH=30 "C"
QL=7200/3600 "kJ/s"
COP=2
QL=Win*COP
```

"Some Wrong Solutions with Common Mistakes:"

```
QL=W1_Win*(TL+273)/(TH-TL) "Using Carnot COP"
QL=W2_Win "Setting work equal to heat input"
QL=W3_Win/COP "Dividing by COP instead of multiplying"
QL=W4_Win*TL/(TH-TL) "Using Carnot COP using C"
```

6-168 Two Carnot heat engines are operating in series such that the heat sink of the first engine serves as the heat source of the second one. If the source temperature of the first engine is 1300 K and the sink temperature of the second engine is 300 K and the thermal efficiencies of both engines are the same, the temperature of the intermediate reservoir is

- (a) 625 K (b) 800 K (c) 860 K (d) 453 K (e) 758 K

Answer (a) 625 K

Solution Solved by EES Software. Solutions can be verified by copying-and-pasting the following lines on a blank EES screen. (Similar problems and their solutions can be obtained easily by modifying numerical values).

TH=1300 "K"

TL=300 "K"

"Setting thermal efficiencies equal to each other:"

1-Tmid/TH=1-TL/Tmid

"Some Wrong Solutions with Common Mistakes:"

W1_Tmid=(TL+TH)/2 "Using average temperature"

6-169 Consider a Carnot refrigerator and a Carnot heat pump operating between the same two thermal energy reservoirs. If the COP of the refrigerator is 3.4, the COP of the heat pump is

- (a) 1.7 (b) 2.4 (c) 3.4 (d) 4.4 (e) 5.0

Answer (d) 4.4

Solution Solved by EES Software. Solutions can be verified by copying-and-pasting the following lines on a blank EES screen. (Similar problems and their solutions can be obtained easily by modifying numerical values).

COP_R=3.4

COP_HP=COP_R+1

"Some Wrong Solutions with Common Mistakes:"

W1_COP=COP_R-1 "Subtracting 1 instead of adding 1"

W2_COP=COP_R "Setting COPs equal to each other"

6-170 A typical new household refrigerator consumes about 680 kWh of electricity per year, and has a coefficient of performance of 1.4. The amount of heat removed by this refrigerator from the refrigerated space per year is

- (a) 952 MJ/yr (b) 1749 MJ/yr (c) 2448 MJ/yr (d) 3427 MJ/yr (e) 4048 MJ/yr

Answer (d) 3427 MJ/yr

Solution Solved by EES Software. Solutions can be verified by copying-and-pasting the following lines on a blank EES screen. (Similar problems and their solutions can be obtained easily by modifying numerical values).

W_in=680*3.6 "MJ"

COP_R=1.4

QL=W_in*COP_R "MJ"

"Some Wrong Solutions with Common Mistakes:"

W1_QL=W_in*COP_R/3.6 "Not using the conversion factor"

W2_QL=W_in "Ignoring COP"

W3_QL=W_in/COP_R "Dividing by COP instead of multiplying"

6-171 A window air conditioner that consumes 1 kW of electricity when running and has a coefficient of performance of 3 is placed in the middle of a room, and is plugged in. The rate of cooling or heating this air conditioner will provide to the air in the room when running is

- (a) 3 kJ/s, cooling (b) 1 kJ/s, cooling (c) 0.33 kJ/s, heating (d) 1 kJ/s, heating (e) 3 kJ/s, heating

Answer (d) 1 kJ/s, heating

Solution Solved by EES Software. Solutions can be verified by copying-and-pasting the following lines on a blank EES screen. (Similar problems and their solutions can be obtained easily by modifying numerical values).

W_in=1 "kW"

COP=3

"From energy balance, heat supplied to the room is equal to electricity consumed,"

E_supplied=W_in "kJ/s, heating"

"Some Wrong Solutions with Common Mistakes:"

W1_E=-W_in "kJ/s, cooling"

W2_E=-COP*W_in "kJ/s, cooling"

W3_E=W_in/COP "kJ/s, heating"

W4_E=COP*W_in "kJ/s, heating"

6-172 ... 6-178 Design and Essay Problems



Solutions Manual for
Thermodynamics: An Engineering Approach
8th Edition
Yunus A. Çengel, Michael A. Boles
McGraw-Hill, 2015

Chapter 7

ENTROPY

PROPRIETARY AND CONFIDENTIAL

This Manual is the proprietary property of McGraw-Hill Education and protected by copyright and other state and federal laws. By opening and using this Manual the user agrees to the following restrictions, and if the recipient does not agree to these restrictions, the Manual should be promptly returned unopened to McGraw-Hill Education: **This Manual is being provided only to authorized professors and instructors for use in preparing for the classes using the affiliated textbook. No other use or distribution of this Manual is permitted. This Manual may not be sold and may not be distributed to or used by any student or other third party. No part of this Manual may be reproduced, displayed or distributed in any form or by any means, electronic or otherwise, without the prior written permission of McGraw-Hill Education.**

Entropy and the Increase of Entropy Principle

7-1C Yes. Because we used the relation $(Q_H/T_H) = (Q_L/T_L)$ in the proof, which is the defining relation of absolute temperature.

7-2C No. A system may reject more (or less) heat than it receives during a cycle. The steam in a steam power plant, for example, receives more heat than it rejects during a cycle.

7-3C Yes.

7-4C That integral should be performed along a reversible path to determine the entropy change.

7-5C No. An isothermal process can be irreversible. Example: A system that involves paddle-wheel work while losing an equivalent amount of heat.

7-6C The value of this integral is always larger for reversible processes.

7-7C No. Because the entropy of the surrounding air increases even more during that process, making the total entropy change positive.

7-8C If the system undergoes a reversible process, the entropy of the system cannot change without a heat transfer. Otherwise, the entropy must increase since there are no offsetting entropy changes associated with reservoirs exchanging heat with the system.

7-9C The claim that work will not change the entropy of a fluid passing through an adiabatic steady-flow system with a single inlet and outlet is true only if the process is also reversible. Since no real process is reversible, there will be an entropy increase in the fluid during the adiabatic process in devices such as pumps, compressors, and turbines.

7-10C Sometimes.

7-11C Never.

7-12C Always.

7-13C Increase.

7-14C Increases.

7-15C Decreases.

7-16C Sometimes.

7-17C Greater than.

7-18C They are heat transfer, irreversibilities, and entropy transport with mass.

7-19E The source and sink temperatures and the entropy change of the sink for a completely reversible heat engine are given. The entropy decrease of the source and the amount of heat transfer from the source are to be determined.

Assumptions The heat engine operates steadily.

Analysis According to the increase in entropy principle, the entropy change of the source must be equal and opposite to that of the sink. Hence,

$$\Delta S_H = -\Delta S_L = -10 \text{ Btu/R}$$

Applying the definition of the entropy to the source gives

$$Q_H = T_H \Delta S_H = (1500 \text{ R})(-10 \text{ Btu/R}) = -15,000 \text{ Btu}$$

which is the heat transfer with respect to the source, not the device.

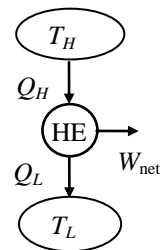

7-20 Air is compressed steadily by a compressor. The air temperature is maintained constant by heat rejection to the surroundings. The rate of entropy change of air is to be determined.

Assumptions 1 This is a steady-flow process since there is no change with time. 2 Kinetic and potential energy changes are negligible. 3 Air is an ideal gas. 4 The process involves no internal irreversibilities such as friction, and thus it is an isothermal, internally reversible process.

Properties Noting that $h = h(T)$ for ideal gases, we have $h_1 = h_2$ since $T_1 = T_2 = 25^\circ\text{C}$.

Analysis We take the compressor as the system. Noting that the enthalpy of air remains constant, the energy balance for this steady-flow system can be expressed in the rate form as

$$\underbrace{\dot{E}_{\text{in}} - \dot{E}_{\text{out}}}_{\text{Rate of net energy transfer by heat, work, and mass}} = \underbrace{\Delta \dot{E}_{\text{system}}}_{\text{Rate of change in internal, kinetic, potential, etc. energies}} \stackrel{\text{no (steady)}}{=} 0$$

$$\dot{E}_{\text{in}} = \dot{E}_{\text{out}}$$

$$\dot{W}_{\text{in}} = \dot{Q}_{\text{out}}$$

Therefore,

$$\dot{Q}_{\text{out}} = \dot{W}_{\text{in}} = 15 \text{ kW}$$

Noting that the process is assumed to be an isothermal and internally reversible process, the rate of entropy change of air is determined to be

$$\Delta \dot{S}_{\text{air}} = -\frac{\dot{Q}_{\text{out,air}}}{T_{\text{sys}}} = -\frac{15 \text{ kW}}{298 \text{ K}} = \mathbf{-0.0503 \text{ kW/K}}$$

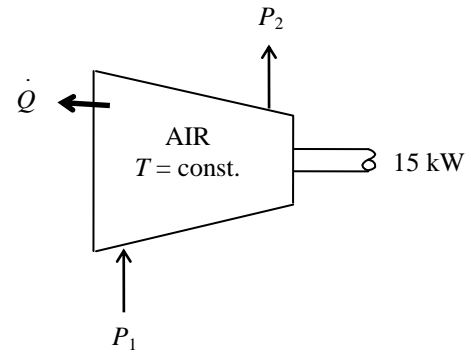

7-21 Heat is transferred directly from an energy-source reservoir to an energy-sink. The entropy change of the two reservoirs is to be calculated and it is to be determined if the increase of entropy principle is satisfied.

Assumptions The reservoirs operate steadily.

Analysis The entropy change of the source and sink is given by

$$\Delta S = \frac{Q_H}{T_H} + \frac{Q_L}{T_L} = \frac{-100 \text{ kJ}}{1200 \text{ K}} + \frac{100 \text{ kJ}}{600 \text{ K}} = \mathbf{0.0833 \text{ kJ/K}}$$

Since the entropy of everything involved in this process has increased, this transfer of heat is **possible**.

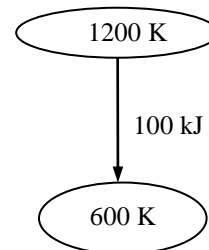

7-22 It is assumed that heat is transferred from a cold reservoir to the hot reservoir contrary to the Clausius statement of the second law. It is to be proven that this violates the increase in entropy principle.

Assumptions The reservoirs operate steadily.

Analysis According to the definition of the entropy, the entropy change of the high-temperature reservoir shown below is

$$\Delta S_H = \frac{Q}{T_H} = \frac{100 \text{ kJ}}{1200 \text{ K}} = 0.08333 \text{ kJ/K}$$

and the entropy change of the low-temperature reservoir is

$$\Delta S_L = \frac{Q}{T_L} = \frac{-100 \text{ kJ}}{600 \text{ K}} = -0.1667 \text{ kJ/K}$$

The total entropy change of everything involved with this system is then

$$\Delta S_{\text{total}} = \Delta S_H + \Delta S_L = 0.08333 - 0.1667 = -0.08333 \text{ kJ/K}$$

which violates the increase in entropy principle since the total entropy change is negative.

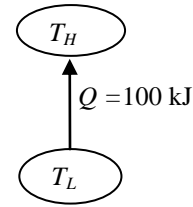

7-23 A reversible heat pump with specified reservoir temperatures is considered. The entropy change of two reservoirs is to be calculated and it is to be determined if this heat pump satisfies the increase in entropy principle.

Assumptions The heat pump operates steadily.

Analysis Since the heat pump is completely reversible, the combination of the coefficient of performance expression, first Law, and thermodynamic temperature scale gives

$$\text{COP}_{\text{HP,rev}} = \frac{1}{1 - T_L/T_H} = \frac{1}{1 - (280 \text{ K})/(297 \text{ K})} = 17.47$$

The power required to drive this heat pump, according to the coefficient of performance, is then

$$\dot{W}_{\text{net,in}} = \frac{\dot{Q}_H}{\text{COP}_{\text{HP,rev}}} = \frac{300 \text{ kW}}{17.47} = 17.17 \text{ kW}$$

According to the first law, the rate at which heat is removed from the low-temperature energy reservoir is

$$\dot{Q}_L = \dot{Q}_H - \dot{W}_{\text{net,in}} = 300 \text{ kW} - 17.17 \text{ kW} = 282.8 \text{ kW}$$

The rate at which the entropy of the high temperature reservoir changes, according to the definition of the entropy, is

$$\Delta \dot{S}_H = \frac{\dot{Q}_H}{T_H} = \frac{300 \text{ kW}}{297 \text{ K}} = 1.01 \text{ kW/K}$$

and that of the low-temperature reservoir is

$$\Delta \dot{S}_L = \frac{\dot{Q}_L}{T_L} = \frac{-17.17 \text{ kW}}{280 \text{ K}} = -1.01 \text{ kW/K}$$

The net rate of entropy change of everything in this system is

$$\Delta \dot{S}_{\text{total}} = \Delta \dot{S}_H + \Delta \dot{S}_L = 1.01 - 1.01 = 0 \text{ kW/K}$$

as it must be since the heat pump is completely reversible.

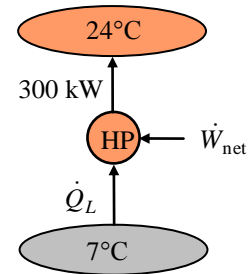

7-24 Heat is transferred isothermally from a source to the working fluid of a Carnot engine. The entropy change of the working fluid, the entropy change of the source, and the total entropy change during this process are to be determined.

Analysis (a) This is a reversible isothermal process, and the entropy change during such a process is given by

$$\Delta S = \frac{Q}{T}$$

Noting that heat transferred from the source is equal to the heat transferred to the working fluid, the entropy changes of the fluid and of the source become

$$\Delta S_{\text{fluid}} = \frac{Q_{\text{fluid}}}{T_{\text{fluid}}} = \frac{Q_{\text{in,fluid}}}{T_{\text{fluid}}} = \frac{900 \text{ kJ}}{673 \text{ K}} = \mathbf{1.337 \text{ kJ/K}}$$

$$(b) \quad \Delta S_{\text{source}} = \frac{Q_{\text{source}}}{T_{\text{source}}} = -\frac{Q_{\text{out,source}}}{T_{\text{source}}} = -\frac{900 \text{ kJ}}{673 \text{ K}} = \mathbf{-1.337 \text{ kJ/K}}$$

(c) Thus the total entropy change of the process is

$$S_{\text{gen}} = \Delta S_{\text{total}} = \Delta S_{\text{fluid}} + \Delta S_{\text{source}} = 1.337 - 1.337 = \mathbf{0}$$

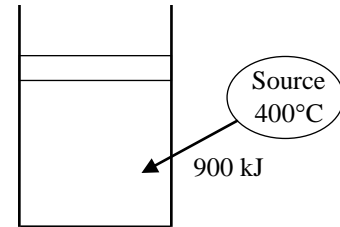



7-25 Problem 7-24 is reconsidered. The effects of the varying the heat transferred to the working fluid and the source temperature on the entropy change of the working fluid, the entropy change of the source, and the total entropy change for the process as the source temperature varies from 100°C to 1000°C are to be investigated. The entropy changes of the source and of the working fluid are to be plotted against the source temperature for heat transfer amounts of 500 kJ, 900 kJ, and 1300 kJ.

Analysis The problem is solved using EES, and the results are tabulated and plotted below.

"Knowns:"

{T_H = 400 [C]}

Q_H = 1300 [kJ]

T_Sys = T_H

"Analysis:

(a) & (b) This is a reversible isothermal process, and the entropy change during such a process is given by $\Delta S = Q/T$ "

"Noting that heat transferred from the source is equal to the heat transferred to the working fluid, the entropy changes of the fluid and of the source become "

$\Delta S_{\text{source}} = -Q_H/(T_H+273)$

$\Delta S_{\text{fluid}} = +Q_H/(T_{\text{Sys}}+273)$

"(c) entropy generation for the process:"

$S_{\text{gen}} = \Delta S_{\text{source}} + \Delta S_{\text{fluid}}$

ΔS_{fluid} [kJ/K]	ΔS_{source} [kJ/K]	S_{gen} [kJ/K]	T_H [C]
3.485	-3.485	0	100
2.748	-2.748	0	200
2.269	-2.269	0	300
1.932	-1.932	0	400
1.682	-1.682	0	500
1.489	-1.489	0	600
1.336	-1.336	0	700
1.212	-1.212	0	800
1.108	-1.108	0	900
1.021	-1.021	0	1000

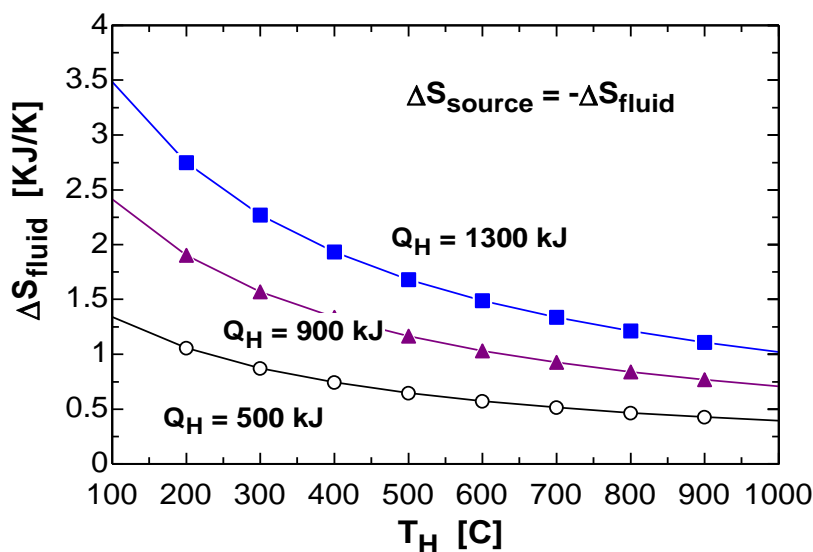

7-26E Heat is transferred isothermally from the working fluid of a Carnot engine to a heat sink. The entropy change of the working fluid is given. The amount of heat transfer, the entropy change of the sink, and the total entropy change during the process are to be determined.

Analysis (a) This is a reversible isothermal process, and the entropy change during such a process is given by

$$\Delta S = \frac{Q}{T}$$

Noting that heat transferred from the working fluid is equal to the heat transferred to the sink, the heat transfer become

$$Q_{\text{fluid}} = T_{\text{fluid}} \Delta S_{\text{fluid}} = (555 \text{ R})(-0.7 \text{ Btu/R}) = -388.5 \text{ Btu} \rightarrow Q_{\text{fluid,out}} = \mathbf{388.5 \text{ Btu}}$$

(b) The entropy change of the sink is determined from

$$\Delta S_{\text{sink}} = \frac{Q_{\text{sink,in}}}{T_{\text{sink}}} = \frac{388.5 \text{ Btu}}{555 \text{ R}} = \mathbf{0.7 \text{ Btu/R}}$$

(c) Thus the total entropy change of the process is

$$S_{\text{gen}} = \Delta S_{\text{total}} = \Delta S_{\text{fluid}} + \Delta S_{\text{sink}} = -0.7 + 0.7 = \mathbf{0}$$

This is expected since all processes of the Carnot cycle are reversible processes, and no entropy is generated during a reversible process.

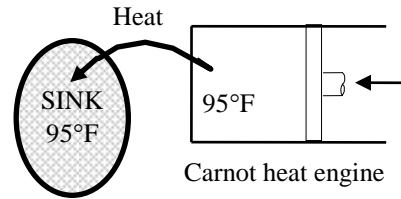

7-27 R-134a enters an evaporator as a saturated liquid-vapor at a specified pressure. Heat is transferred to the refrigerant from the cooled space, and the liquid is vaporized. The entropy change of the refrigerant, the entropy change of the cooled space, and the total entropy change for this process are to be determined.

Assumptions 1 Both the refrigerant and the cooled space involve no internal irreversibilities such as friction. **2** Any temperature change occurs within the wall of the tube, and thus both the refrigerant and the cooled space remain isothermal during this process. Thus it is an isothermal, internally reversible process.

Analysis Noting that both the refrigerant and the cooled space undergo reversible isothermal processes, the entropy change for them can be determined from

$$\Delta S = \frac{Q}{T}$$

(a) The pressure of the refrigerant is maintained constant. Therefore, the temperature of the refrigerant also remains constant at the saturation value,

$$T = T_{\text{sat}@140 \text{ kPa}} = -18.77^\circ\text{C} = 254.4 \text{ K} \quad (\text{Table A-12})$$

$$\text{Then, } \Delta S_{\text{refrigerant}} = \frac{Q_{\text{refrigerant,in}}}{T_{\text{refrigerant}}} = \frac{180 \text{ kJ}}{254.4 \text{ K}} = \mathbf{0.7076 \text{ kJ/K}}$$

(b) Similarly,

$$\Delta S_{\text{space}} = -\frac{Q_{\text{space,out}}}{T_{\text{space}}} = -\frac{180 \text{ kJ}}{263 \text{ K}} = \mathbf{-0.6844 \text{ kJ/K}}$$

(c) The total entropy change of the process is

$$S_{\text{gen}} = \Delta S_{\text{total}} = \Delta S_{\text{refrigerant}} + \Delta S_{\text{space}} = 0.7076 - 0.6844 = \mathbf{0.0232 \text{ kJ/K}}$$

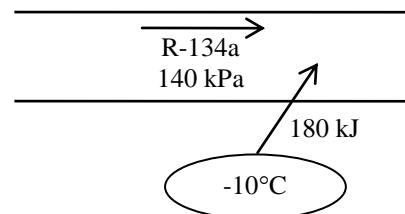

Entropy Changes of Pure Substances

7-28C Yes, because an internally reversible, adiabatic process involves no irreversibilities or heat transfer.

7-29E A piston-cylinder device that is filled with water is heated. The total entropy change is to be determined.

Analysis The initial specific volume is

$$\nu_1 = \frac{V_1}{m} = \frac{2.5 \text{ ft}^3}{2 \text{ lbm}} = 1.25 \text{ ft}^3/\text{lbm}$$

which is between ν_f and ν_g for 300 psia. The initial quality and the entropy are then (Table A-5E)

$$x_1 = \frac{\nu_1 - \nu_f}{\nu_{fg}} = \frac{(1.25 - 0.01890) \text{ ft}^3/\text{lbm}}{(1.5435 - 0.01890) \text{ ft}^3/\text{lbm}} = 0.8075$$

$$s_1 = s_f + x_1 s_{fg} = 0.58818 \text{ Btu/lbm} \cdot \text{R} + (0.8075)(0.92289 \text{ Btu/lbm} \cdot \text{R}) = 1.3334 \text{ Btu/lbm} \cdot \text{R}$$

The final state is superheated vapor and

$$\left. \begin{array}{l} T_2 = 500^\circ\text{F} \\ P_2 = P_1 = 300 \text{ psia} \end{array} \right\} s_2 = 1.5706 \text{ Btu/lbm} \cdot \text{R} \quad (\text{Table A-6E})$$

Hence, the change in the total entropy is

$$\begin{aligned} \Delta S &= m(s_2 - s_1) \\ &= (2 \text{ lbm})(1.5706 - 1.3334) \text{ Btu/lbm} \cdot \text{R} \\ &= \mathbf{0.4744 \text{ Btu/R}} \end{aligned}$$

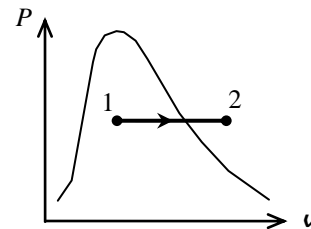
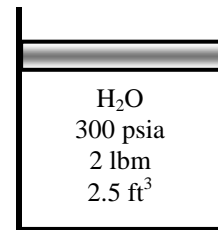

7-30 An insulated rigid tank contains a saturated liquid-vapor mixture of water at a specified pressure. An electric heater inside is turned on and kept on until all the liquid vaporized. The entropy change of the water during this process is to be determined.

Analysis From the steam tables (Tables A-4 through A-6)

$$\left. \begin{array}{l} P_1 = 200 \text{ kPa} \\ x_1 = 0.25 \end{array} \right\} \begin{array}{l} \nu_1 = \nu_f + x_1 \nu_{fg} = 0.001061 + (0.25)(0.88578 - 0.001061) = 0.22224 \text{ m}^3/\text{kg} \\ s_1 = s_f + x_1 s_{fg} = 1.5302 + (0.25)(5.5968) = 2.9294 \text{ kJ/kg} \cdot \text{K} \end{array}$$

$$\left. \begin{array}{l} \nu_2 = \nu_1 = 0.22224 \text{ m}^3/\text{kg} \\ x_2 = 1 \text{ (sat. vapor)} \end{array} \right\} s_2 = 6.6335 \text{ kJ/kg} \cdot \text{K}$$

Then the entropy change of the steam becomes

$$\Delta S = m(s_2 - s_1) = (3 \text{ kg})(6.6335 - 2.9294) \text{ kJ/kg} \cdot \text{K} = \mathbf{11.1 \text{ kJ/K}}$$

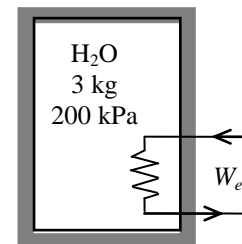

7-31 The radiator of a steam heating system is initially filled with superheated steam. The valves are closed, and steam is allowed to cool until the temperature drops to a specified value by transferring heat to the room. The entropy change of the steam during this process is to be determined.

Analysis From the steam tables (Tables A-4 through A-6),

$$\left. \begin{array}{l} P_1 = 200 \text{ kPa} \\ T_1 = 150^\circ\text{C} \end{array} \right\} \begin{array}{l} \nu_1 = 0.95986 \text{ m}^3/\text{kg} \\ s_1 = 7.2810 \text{ kJ/kg} \cdot \text{K} \end{array}$$

$$\left. \begin{array}{l} T_2 = 40^\circ\text{C} \\ \nu_2 = \nu_1 \end{array} \right\} x_2 = \frac{\nu_2 - \nu_f}{\nu_{fg}} = \frac{0.95986 - 0.001008}{19.515 - 0.001008} = 0.04914$$

$$s_2 = s_f + x_2 s_{fg} = 0.5724 + (0.04914)(7.6832) = 0.9499 \text{ kJ/kg} \cdot \text{K}$$

The mass of the steam is

$$m = \frac{\nu}{\nu_1} = \frac{0.020 \text{ m}^3}{0.95986 \text{ m}^3/\text{kg}} = 0.02084 \text{ kg}$$

Then the entropy change of the steam during this process becomes

$$\Delta S = m(s_2 - s_1) = (0.02084 \text{ kg})(0.9499 - 7.2810) \text{ kJ/kg} \cdot \text{K} = \mathbf{-0.132 \text{ kJ/K}}$$

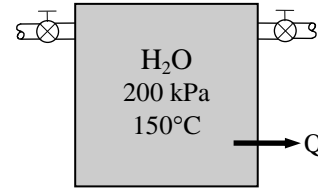

7-32 A rigid tank is divided into two equal parts by a partition. One part is filled with compressed liquid water while the other side is evacuated. The partition is removed and water expands into the entire tank. The entropy change of the water during this process is to be determined.

Analysis The properties of the water are (Table A-4)

$$\left. \begin{array}{l} P_1 = 400 \text{ kPa} \\ T_1 = 60^\circ\text{C} \end{array} \right\} \begin{array}{l} \nu_1 \cong \nu_{f@60^\circ\text{C}} = 0.001017 \text{ m}^3/\text{kg} \\ s_1 = s_{f@60^\circ\text{C}} = 0.8313 \text{ kJ/kg} \cdot \text{K} \end{array}$$

Noting that

$$\nu_2 = 2\nu_1 = (2)(0.001017) = 0.002034 \text{ m}^3/\text{kg}$$

$$\left. \begin{array}{l} P_2 = 40 \text{ kPa} \\ \nu_2 = 0.002034 \text{ m}^3/\text{kg} \end{array} \right\} \begin{array}{l} x_2 = \frac{\nu_2 - \nu_f}{\nu_{fg}} = \frac{0.002034 - 0.001026}{3.993 - 0.001026} = 0.0002524 \\ s_2 = s_f + x_2 s_{fg} = 1.0261 + (0.0002524)(6.6430) = 1.0278 \text{ kJ/kg} \cdot \text{K} \end{array}$$

Then the entropy change of the water becomes

$$\Delta S = m(s_2 - s_1) = (2.5 \text{ kg})(1.0278 - 0.8313) \text{ kJ/kg} \cdot \text{K} = \mathbf{0.492 \text{ kJ/K}}$$

2.5 kg compressed liquid	Vacuum
400 kPa 60°C	

7-33 An insulated cylinder is initially filled with saturated liquid water at a specified pressure. The water is heated electrically at constant pressure. The entropy change of the water during this process is to be determined.

Assumptions 1 The kinetic and potential energy changes are negligible. **2** The cylinder is well-insulated and thus heat transfer is negligible. **3** The thermal energy stored in the cylinder itself is negligible. **4** The compression or expansion process is quasi-equilibrium.

Analysis From the steam tables (Tables A-4 through A-6),

$$P_1 = 150 \text{ kPa} \left. \begin{array}{l} \nu_1 = \nu_{f@150 \text{ kPa}} = 0.001053 \text{ m}^3/\text{kg} \\ \text{sat.liquid} \left\{ \begin{array}{l} h_1 = h_{f@150 \text{ kPa}} = 467.13 \text{ kJ/kg} \\ s_1 = s_{f@150 \text{ kPa}} = 1.4337 \text{ kJ/kg} \cdot \text{K} \end{array} \right. \end{array} \right\}$$

Also,

$$m = \frac{V}{\nu_1} = \frac{0.005 \text{ m}^3}{0.001053 \text{ m}^3/\text{kg}} = 4.75 \text{ kg}$$

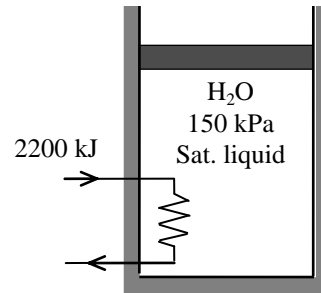

We take the contents of the cylinder as the system. This is a closed system since no mass enters or leaves. The energy balance for this stationary closed system can be expressed as

$$\underbrace{E_{\text{in}} - E_{\text{out}}}_{\substack{\text{Net energy transfer} \\ \text{by heat, work, and mass}}} = \underbrace{\Delta E_{\text{system}}}_{\substack{\text{Change in internal, kinetic,} \\ \text{potential, etc. energies}}}$$

$$W_{\text{e,in}} - W_{\text{b,out}} = \Delta U$$

$$W_{\text{e,in}} = m(h_2 - h_1)$$

since $\Delta U + W_b = \Delta H$ during a constant pressure quasi-equilibrium process. Solving for h_2 ,

$$h_2 = h_1 + \frac{W_{\text{e,in}}}{m} = 467.13 + \frac{2200 \text{ kJ}}{4.75 \text{ kg}} = 930.33 \text{ kJ/kg}$$

Thus,

$$P_2 = 150 \text{ kPa} \left. \begin{array}{l} x_2 = \frac{h_2 - h_f}{h_{fg}} = \frac{930.33 - 467.13}{2226.0} = 0.2081 \\ h_2 = 930.33 \text{ kJ/kg} \left\{ \begin{array}{l} s_2 = s_f + x_2 s_{fg} = 1.4337 + (0.2081)(5.7894) = 2.6384 \text{ kJ/kg} \cdot \text{K} \end{array} \right. \end{array} \right\}$$

Then the entropy change of the water becomes

$$\Delta S = m(s_2 - s_1) = (4.75 \text{ kg})(2.6384 - 1.4337) \text{ kJ/kg} \cdot \text{K} = \mathbf{5.72 \text{ kJ/K}}$$

7-34E R-134a is compressed in a compressor during which the entropy remains constant. The final temperature and enthalpy change are to be determined.

Analysis The initial state is saturated vapor and the properties are (Table A-11E)

$$h_1 = h_g @ 6^\circ\text{F} = 103.98 \text{ Btu/lbm}$$

$$s_1 = s_g @ 6^\circ\text{F} = 0.22477 \text{ Btu/lbm} \cdot \text{R}$$

The final state is superheated vapor and the properties are (Table A-13E)

$$\left. \begin{array}{l} P_2 = 80 \text{ psia} \\ s_2 = s_1 = 0.22477 \text{ Btu/lbm} \cdot \text{R} \end{array} \right\} \begin{array}{l} T_2 = \mathbf{75.7^\circ\text{F}} \\ h_2 = 114.52 \text{ Btu/lbm} \end{array}$$

The change in the enthalpy across the compressor is then

$$\Delta h = h_2 - h_1 = 114.52 - 103.98 = \mathbf{10.5 \text{ Btu/lbm}}$$

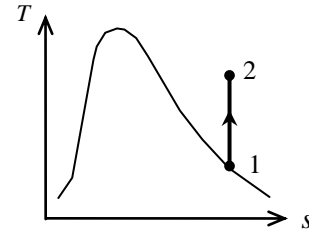

7-35 Water vapor is expanded in a turbine during which the entropy remains constant. The enthalpy difference is to be determined.

Analysis The initial state is superheated vapor and thus

$$\left. \begin{array}{l} P_1 = 6 \text{ MPa} \\ T_1 = 400^\circ\text{C} \end{array} \right\} \begin{array}{l} h_1 = 3178.3 \text{ kJ/kg} \\ s_1 = 6.5432 \text{ kJ/kg} \cdot \text{K} \end{array} \quad (\text{Table A-6})$$

The entropy is constant during the process. The final state is a mixture since the entropy is between s_f and s_g for 100 kPa. The properties at this state are (Table A-5)

$$x_2 = \frac{s_2 - s_f}{s_{fg}} = \frac{(6.5432 - 1.3028) \text{ kJ/kg} \cdot \text{K}}{6.0562 \text{ kJ/kg} \cdot \text{K}} = 0.8653$$

$$h_2 = h_f + x_2 h_{fg} = 417.51 + (0.8653)(2257.5) = 2370.9 \text{ kJ/kg}$$

The change in the enthalpy across the turbine is then

$$\Delta h = h_2 - h_1 = 2370.9 - 3178.3 = \mathbf{-807.4 \text{ kJ/kg}}$$

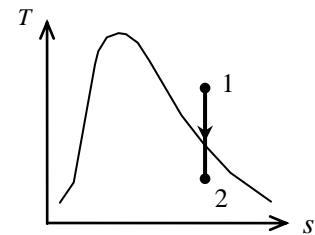

7-36 R-134a undergoes a process during which the entropy is kept constant. The final temperature and internal energy are to be determined.

Analysis The initial entropy is

$$\left. \begin{array}{l} T_1 = 25^\circ\text{C} \\ P_1 = 600 \text{ kPa} \end{array} \right\} s_1 = 0.9335 \text{ kJ/kg} \cdot \text{K} \quad (\text{Table A - 13})$$

The entropy is constant during the process. The final state is a mixture since the entropy is between s_f and s_g for 100 kPa. The properties at this state are (Table A-12)

$$T_2 = T_{\text{sat @ 100 kPa}} = \mathbf{-26.37^\circ\text{C}}$$

$$x_2 = \frac{s_2 - s_f}{s_{fg}} = \frac{(0.9335 - 0.07182) \text{ kJ/kg} \cdot \text{K}}{0.8801 \text{ kJ/kg} \cdot \text{K}} = 0.9791$$

$$u_2 = u_f + x_2 u_{fg} = 17.19 + (0.9791)(198.01) = \mathbf{211.1 \text{ kJ/kg}}$$

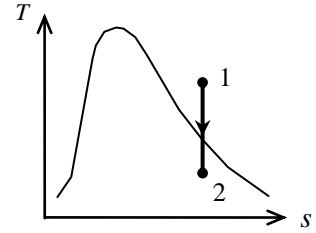

7-37 Refrigerant-134a is expanded in a turbine during which the entropy remains constant. The inlet and outlet velocities are to be determined.

Analysis The initial state is superheated vapor and thus

$$\left. \begin{array}{l} P_1 = 600 \text{ kPa} \\ T_1 = 70^\circ\text{C} \end{array} \right\} \left. \begin{array}{l} v_1 = 0.04307 \text{ m}^3/\text{kg} \\ s_1 = 1.0706 \text{ kJ/kg} \cdot \text{K} \end{array} \right\} \quad (\text{Table A - 13})$$

The entropy is constant during the process. The properties at the exit state are

$$\left. \begin{array}{l} P_2 = 100 \text{ kPa} \\ s_2 = s_1 = 1.0706 \text{ kJ/kg} \cdot \text{K} \end{array} \right\} v_2 = 0.2274 \text{ m}^3/\text{kg} \quad (\text{Table A - 13})$$

The inlet and outlet velocities are

$$V_1 = \frac{\dot{m} v_1}{A_1} = \frac{(0.75 \text{ kg/s})(0.04307 \text{ m}^3/\text{kg})}{0.5 \text{ m}^2} = \mathbf{0.0646 \text{ m/s}}$$

$$V_2 = \frac{\dot{m} v_2}{A_2} = \frac{(0.75 \text{ kg/s})(0.2274 \text{ m}^3/\text{kg})}{1.0 \text{ m}^2} = \mathbf{0.171 \text{ m/s}}$$

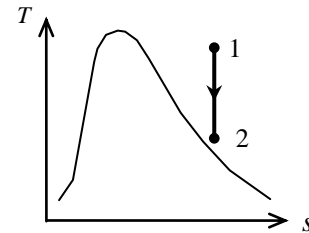

7-38 A cylinder is initially filled with saturated water vapor at a specified temperature. Heat is transferred to the steam, and it expands in a reversible and isothermal manner until the pressure drops to a specified value. The heat transfer and the work output for this process are to be determined.

Assumptions 1 The kinetic and potential energy changes are negligible. **2** The cylinder is well-insulated and thus heat transfer is negligible. **3** The thermal energy stored in the cylinder itself is negligible. **4** The process is stated to be reversible and isothermal.

Analysis From the steam tables (Tables A-4 through A-6),

$$\left. \begin{array}{l} T_1 = 200^\circ\text{C} \\ \text{sat. vapor} \end{array} \right\} \begin{array}{l} u_1 = u_{g@200^\circ\text{C}} = 2594.2 \text{ kJ/kg} \\ s_1 = s_{g@200^\circ\text{C}} = 6.4302 \text{ kJ/kg} \cdot \text{K} \end{array}$$

$$\left. \begin{array}{l} P_2 = 800 \text{ kPa} \\ T_2 = T_1 \end{array} \right\} \begin{array}{l} u_2 = 2631.1 \text{ kJ/kg} \\ s_2 = 6.8177 \text{ kJ/kg} \cdot \text{K} \end{array}$$

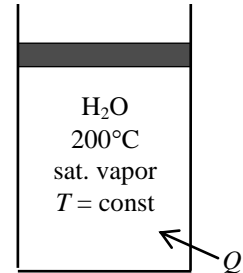

The heat transfer for this reversible isothermal process can be determined from

$$Q = T\Delta S = Tm(s_2 - s_1) = (473 \text{ K})(1.2 \text{ kg})(6.8177 - 6.4302) \text{ kJ/kg} \cdot \text{K} = \mathbf{219.9 \text{ kJ}}$$

We take the contents of the cylinder as the system. This is a closed system since no mass enters or leaves. The energy balance for this closed system can be expressed as

$$\underbrace{E_{\text{in}} - E_{\text{out}}}_{\substack{\text{Net energy transfer} \\ \text{by heat, work, and mass}}} = \underbrace{\Delta E_{\text{system}}}_{\substack{\text{Change in internal, kinetic,} \\ \text{potential, etc. energies}}}$$

$$Q_{\text{in}} - W_{\text{b,out}} = \Delta U = m(u_2 - u_1)$$

$$W_{\text{b,out}} = Q_{\text{in}} - m(u_2 - u_1)$$

Substituting, the work done during this process is determined to be

$$W_{\text{b,out}} = 219.9 \text{ kJ} - (1.2 \text{ kg})(2631.1 - 2594.2) \text{ kJ/kg} = \mathbf{175.6 \text{ kJ}}$$



7-39 Problem 7-38 is reconsidered. The heat transferred to the steam and the work done are to be determined and plotted as a function of final pressure as the pressure varies from the initial value to the final value of 800 kPa.

Analysis The problem is solved using EES, and the results are tabulated and plotted below.

"Knowns:"

T_1 = 200 [C]
 x_1 = 1.0
 m_sys = 1.2 [kg]
 {P_2 = 800"[kPa]"}

"Analysis: "

Fluid\$='Steam_IAPWS'

" Treat the piston-cylinder as a closed system, neglect changes in KE and PE of the Steam. The process is reversible and isothermal ."

T_2 = T_1
 E_in - E_out = DELTAE_sys
 E_in = Q_in
 E_out = Work_out
 DELTAE_sys = m_sys*(u_2 - u_1)
 P_1 = pressure(Fluid\$,T=T_1,x=1.0)
 u_1 = INTENERGY(Fluid\$,T=T_1,x=1.0)
 v_1 = volume(Fluid\$,T=T_1,x=1.0)
 s_1 = entropy(Fluid\$,T=T_1,x=1.0)
 V_sys = m_sys*v_1

" The process is reversible and isothermal. Then P_2 and T_2 specify state 2."

u_2 = INTENERGY(Fluid\$,P=P_2,T=T_2)
 s_2 = entropy(Fluid\$,P=P_2,T=T_2)
 Q_in= (T_1+273)*m_sys*(s_2-s_1)

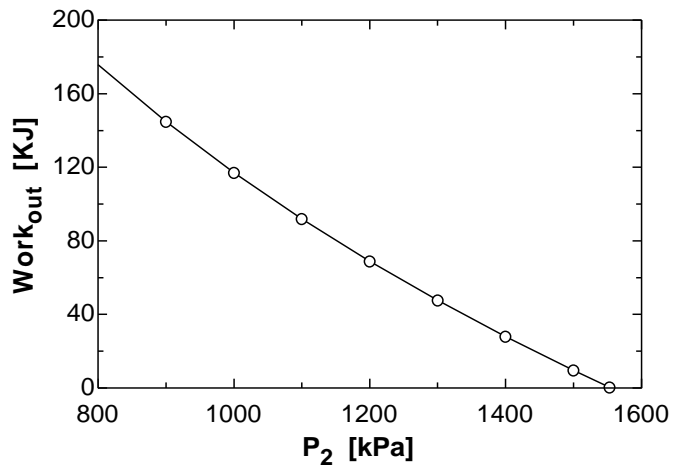

P ₂ [kPa]	Q _{in} [kJ]	Work _{out} [kJ]
800	219.9	175.7
900	183.7	144.7
1000	150.6	117
1100	120	91.84
1200	91.23	68.85
1300	64.08	47.65
1400	38.2	27.98
1500	13.32	9.605
1553	0.4645	0.3319

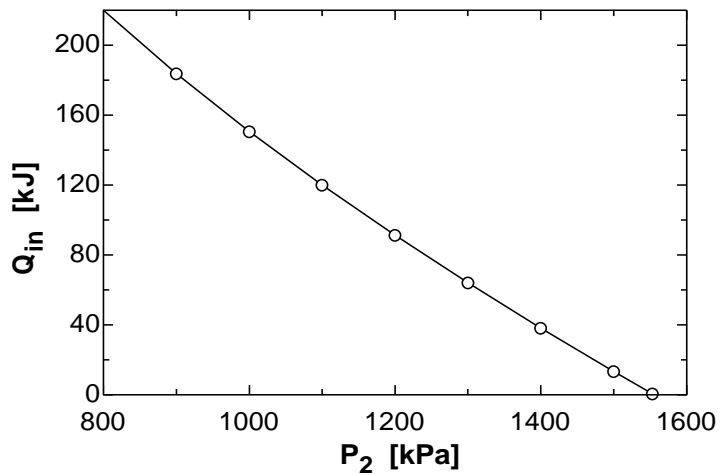

7-40 R-134a undergoes an isothermal process in a closed system. The work and heat transfer are to be determined.

Assumptions 1 The system is stationary and thus the kinetic and potential energy changes are zero. **2** There are no work interactions involved other than the boundary work. **3** The thermal energy stored in the cylinder itself is negligible. **4** The compression or expansion process is quasi-equilibrium.

Analysis The energy balance for this system can be expressed as

$$\underbrace{E_{\text{in}} - E_{\text{out}}}_{\text{Net energy transfer by heat, work, and mass}} = \underbrace{\Delta E_{\text{system}}}_{\text{Change in internal, kinetic, potential, etc. energies}}$$

$$W_{\text{in}} - Q_{\text{out}} = \Delta U = m(u_2 - u_1)$$

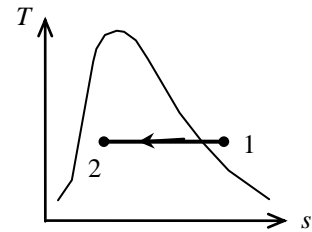
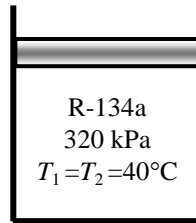

The initial state properties are

$$\left. \begin{array}{l} P_1 = 320 \text{ kPa} \\ T_1 = 40^\circ\text{C} \end{array} \right\} \begin{array}{l} u_1 = 261.62 \text{ kJ/kg} \\ s_1 = 1.0452 \text{ kJ/kg} \cdot \text{K} \end{array} \quad (\text{Table A - 13})$$

For this isothermal process, the final state properties are (Table A-11)

$$\left. \begin{array}{l} T_2 = T_1 = 40^\circ\text{C} \\ x_2 = 0.45 \end{array} \right\} \begin{array}{l} u_2 = u_f + x_2 u_{fg} = 107.39 + (0.45)(143.61) = 172.02 \text{ kJ/kg} \\ s_2 = s_f + x_2 s_{fg} = 0.39493 + (0.45)(0.52059) = 0.62920 \text{ kJ/kg} \cdot \text{K} \end{array}$$

The heat transfer is determined from

$$q_{\text{in}} = T_0 (s_2 - s_1) = (313 \text{ K})(0.62920 - 1.0452) \text{ kJ/kg} \cdot \text{K} = -130.2 \text{ kJ/kg}$$

The negative sign shows that the heat is actually transferred from the system. That is,

$$q_{\text{out}} = \mathbf{130.2 \text{ kJ/kg}}$$

The work required is determined from the energy balance to be

$$w_{\text{in}} = q_{\text{out}} + (u_2 - u_1) = 130.2 \text{ kJ/kg} + (172.02 - 261.62) \text{ kJ/kg} = \mathbf{40.6 \text{ kJ/kg}}$$

7-41 A rigid tank contains saturated water vapor at a specified temperature. Steam is cooled to ambient temperature. The process is to be sketched and entropy changes for the steam and for the process are to be determined.

Assumptions 1 The kinetic and potential energy changes are negligible.

Analysis (b) From the steam tables (Tables A-4 through A-6),

$$\begin{aligned}
 & \left. \begin{array}{l} T_1 = 100^\circ\text{C} \\ x = 1 \end{array} \right\} \begin{array}{l} v_1 = v_g = 1.6720 \text{ m}^3/\text{kg} \\ u_1 = u_g = 2506.0 \text{ kJ/kg} \\ s_1 = 7.3542 \text{ kJ/kg}\cdot\text{K} \end{array} \\
 & \left. \begin{array}{l} T_2 = 25^\circ\text{C} \\ v_2 = v_1 \end{array} \right\} \begin{array}{l} x_2 = 0.03856 \\ u_2 = 193.67 \text{ kJ/kg} \\ s_2 = 0.6830 \text{ kJ/kg}\cdot\text{K} \end{array}
 \end{aligned}$$

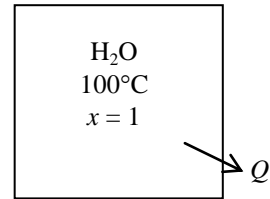

The entropy change of steam is determined from

$$\Delta S_w = m(s_2 - s_1) = (5 \text{ kg})(0.6830 - 7.3542) \text{ kJ/kg}\cdot\text{K} = \mathbf{-33.36 \text{ kJ/K}}$$

(c) We take the contents of the tank as the system. This is a closed system since no mass enters or leaves. The energy balance for this closed system can be expressed as

$$\begin{aligned}
 \underbrace{E_{\text{in}} - E_{\text{out}}}_{\substack{\text{Net energy transfer} \\ \text{by heat, work, and mass}}} &= \underbrace{\Delta E_{\text{system}}}_{\substack{\text{Change in internal, kinetic,} \\ \text{potential, etc. energies}}} \\
 -Q_{\text{out}} = \Delta U &= m(u_2 - u_1)
 \end{aligned}$$

That is,

$$Q_{\text{out}} = m(u_1 - u_2) = (5 \text{ kg})(2506.0 - 193.67) \text{ kJ/kg} = 11,562 \text{ kJ}$$

The total entropy change for the process is

$$S_{\text{gen}} = \Delta S_w + \frac{Q_{\text{out}}}{T_{\text{surr}}} = -33.36 \text{ kJ/K} + \frac{11,562 \text{ kJ}}{298 \text{ K}} = \mathbf{5.44 \text{ kJ/K}}$$

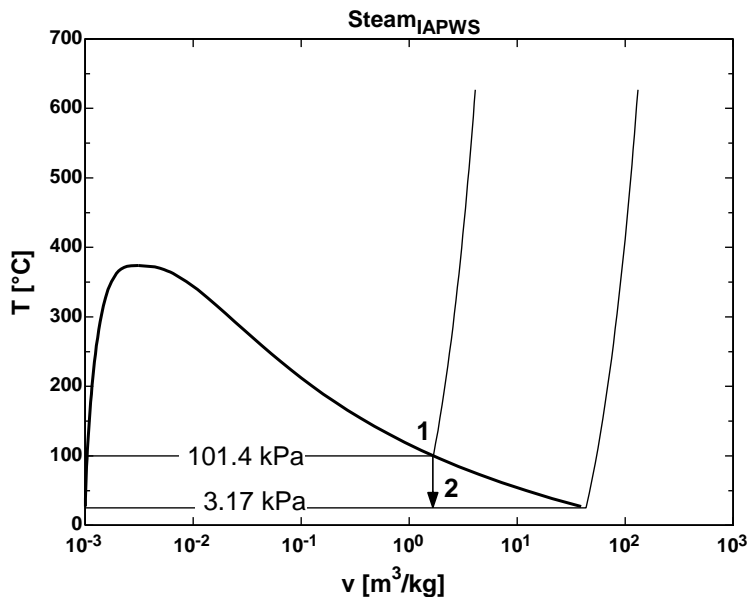

7-42 A rigid tank is initially filled with a saturated mixture of R-134a. Heat is transferred to the tank from a source until the pressure inside rises to a specified value. The entropy change of the refrigerant, entropy change of the source, and the total entropy change for this process are to be determined.

Assumptions 1 The tank is stationary and thus the kinetic and potential energy changes are zero. **2** There are no work interactions.

Analysis (a) From the refrigerant tables (Tables A-11 through A-13),

$$\left. \begin{array}{l} P_1 = 200 \text{ kPa} \\ x_1 = 0.4 \end{array} \right\} \begin{array}{l} u_1 = u_f + x_1 u_{fg} = 38.26 + (0.4)(186.25) = 112.76 \text{ kJ/kg} \\ s_1 = s_f + x_1 s_{fg} = 0.15449 + (0.4)(0.78339) = 0.4678 \text{ kJ/kg} \cdot \text{K} \\ v_1 = v_f + x_1 v_{fg} = 0.0007532 + (0.4)(0.099951 - 0.0007532) = 0.04043 \text{ m}^3/\text{kg} \end{array}$$

$$\left. \begin{array}{l} P_2 = 400 \text{ kPa} \\ v_2 = v_1 \end{array} \right\} \begin{array}{l} x_2 = \frac{v_2 - v_f}{v_{fg}} = \frac{0.04043 - 0.0007905}{0.051266 - 0.0007905} = 0.7853 \\ u_2 = u_f + x_2 u_{fg} = 63.61 + (0.7853)(171.49) = 198.29 \text{ kJ/kg} \\ s_2 = s_f + x_2 s_{fg} = 0.24757 + (0.7853)(0.67954) = 0.7813 \text{ kJ/kg} \cdot \text{K} \end{array}$$

The mass of the refrigerant is

$$m = \frac{v}{v_1} = \frac{0.5 \text{ m}^3}{0.04043 \text{ m}^3/\text{kg}} = 12.37 \text{ kg}$$

Then the entropy change of the refrigerant becomes

$$\Delta S_{\text{system}} = m(s_2 - s_1) = (12.37 \text{ kg})(0.7813 - 0.4678) \text{ kJ/kg} \cdot \text{K} = \mathbf{3.876 \text{ kJ/K}}$$

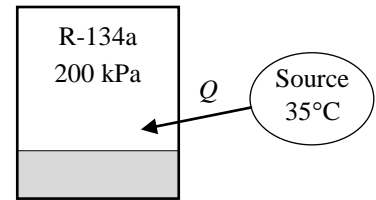

(b) We take the tank as the system. This is a closed system since no mass enters or leaves. Noting that the volume of the system is constant and thus there is no boundary work, the energy balance for this stationary closed system can be expressed as

$$\underbrace{E_{\text{in}} - E_{\text{out}}}_{\substack{\text{Net energy transfer} \\ \text{by heat, work, and mass}}} = \underbrace{\Delta E_{\text{system}}}_{\substack{\text{Change in internal, kinetic,} \\ \text{potential, etc. energies}}} \\ Q_{\text{in}} = \Delta U = m(u_2 - u_1)$$

Substituting,

$$Q_{\text{in}} = m(u_2 - u_1) = (12.37 \text{ kg})(198.29 - 112.76) = 1058 \text{ kJ}$$

The heat transfer for the source is equal in magnitude but opposite in direction. Therefore,

$$Q_{\text{source, out}} = -Q_{\text{tank, in}} = -1058 \text{ kJ}$$

and

$$\Delta S_{\text{source}} = -\frac{Q_{\text{source, out}}}{T_{\text{source}}} = -\frac{1058 \text{ kJ}}{308 \text{ K}} = \mathbf{-3.434 \text{ kJ/K}}$$

(c) The total entropy change for this process is

$$\Delta S_{\text{total}} = \Delta S_{\text{system}} + \Delta S_{\text{source}} = 3.876 + (-3.434) = \mathbf{0.441 \text{ kJ/K}}$$



7-43 Problem 7-42 is reconsidered. The effects of the source temperature and final pressure on the total entropy change for the process as the source temperature varies from 30°C to 210°C, and the final pressure varies from 250 kPa to 500 kPa are to be investigated. The total entropy change for the process is to be plotted as a function of the source temperature for final pressures of 250 kPa, 400 kPa, and 500 kPa.

Analysis The problem is solved using EES, and the results are tabulated and plotted below.

"Knowns:"

P_1 = 200 [kPa]
 x_1 = 0.4
 V_sys = 0.5 [m^3]
 P_2 = 400 [kPa]
 {T_source = 35 [C]}

"Analysis: "

" Treat the rigid tank as a closed system, with no work in, neglect changes in KE and PE of the R134a."

E_in - E_out = DELTAE_sys
 E_out = 0 [kJ]
 E_in = Q
 DELTAE_sys = m_sys*(u_2 - u_1)
 u_1 = INTENERGY(R134a,P=P_1,x=x_1)
 v_1 = volume(R134a,P=P_1,x=x_1)
 V_sys = m_sys*v_1

"Rigid Tank: The process is constant volume. Then P_2 and v_2 specify state 2."

v_2 = v_1
 u_2 = INTENERGY(R134a,P=P_2,v=v_2)

"Entropy calculations:"

s_1 = entropy(R134a,P=P_1,x=x_1)
 s_2 = entropy(R134a,P=P_2,v=v_2)
 DELTAS_sys = m_sys*(s_2 - s_1)

"Heat is leaving the source, thus:"

DELTA_S_source = -Q/(T_source + 273)

"Total Entropy Change:"

DELTA_S_total = DELTA_S_source + DELTA_S_sys

ΔS_{total} [kJ/K]	T_{source} [C]
0.3848	30
0.6997	60
0.9626	90
1.185	120
1.376	150
1.542	180
1.687	210

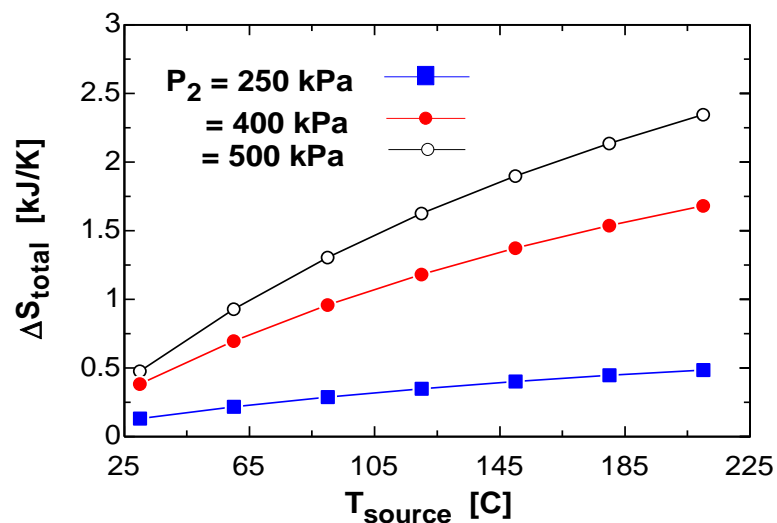

7-44 The heat transfer during the process shown in the figure is to be determined.

Assumptions The process is reversible.

Analysis No heat is transferred during the process 2-3 since the area under process line is zero. Then the heat transfer is equal to the area under the process line 1-2:

$$\begin{aligned} q_{12} &= \int_1^2 T ds = \text{Area} = \frac{T_1 + T_2}{2} (s_2 - s_1) \\ &= \frac{(600 + 273)\text{K} + (200 + 273)\text{K}}{2} (1.0 - 0.3)\text{kJ/kg} \cdot \text{K} \\ &= \mathbf{471\text{kJ/kg}} \end{aligned}$$

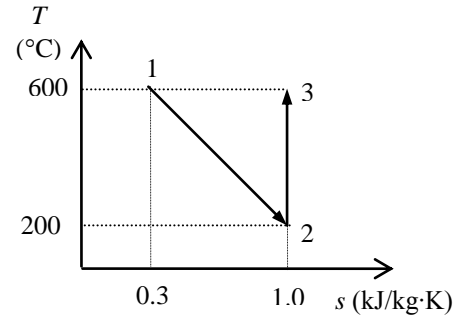

7-45E The heat transfer during the process shown in the figure is to be determined.

Assumptions The process is reversible.

Analysis Heat transfer is equal to the sum of the areas under the process 1-2 and 2-3.

$$\begin{aligned} q_{12} &= \int_1^2 T ds + \int_2^3 T ds = \frac{T_1 + T_2}{2} (s_2 - s_1) + T_2 (s_3 - s_2) \\ &= \frac{(55 + 460)\text{R} + (360 + 460)\text{R}}{2} (3.0 - 1.0)\text{Btu/lbm} \cdot \text{R} \\ &\quad + [(360 + 460)\text{R}] (2.0 - 3.0)\text{Btu/lbm} \cdot \text{R} \\ &= \mathbf{515\text{Btu/lbm}} \end{aligned}$$

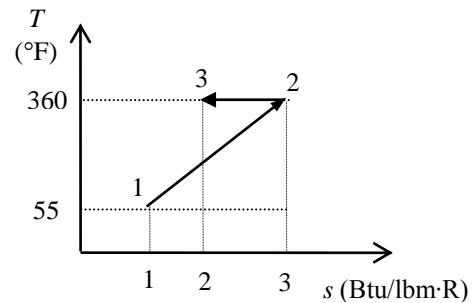

7-46 Steam enters a diffuser at a specified state and leaves at a specified pressure. The minimum outlet velocity is to be determined.

Analysis The inlet state is superheated vapor and thus

$$\left. \begin{array}{l} P_1 = 150 \text{ kPa} \\ T_1 = 120^\circ\text{C} \end{array} \right\} \begin{array}{l} h_1 = 2711.4 \text{ kJ/kg} \\ s_1 = 7.2699 \text{ kJ/kg} \cdot \text{K} \end{array} \quad (\text{Table A - 6})$$

For minimum velocity at the exit, the entropy will be constant during the process. The exit state enthalpy is (Table A-6)

$$\left. \begin{array}{l} P_2 = 300 \text{ kPa} \\ s_2 = s_1 = 7.2699 \text{ kJ/kg} \cdot \text{K} \end{array} \right\} h_2 = 2845.7 \text{ kJ/kg} \quad (\text{Table A - 6})$$

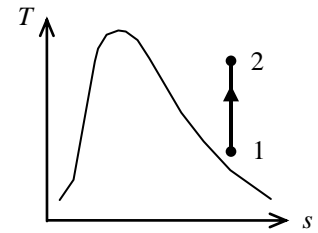

We take the diffuser as the system, which is a control volume since mass crosses the boundary. Noting that one fluid stream enters and leaves the diffuser, the energy balance for this steady-flow system can be expressed in the rate form as

$$\underbrace{\dot{E}_{\text{in}} - \dot{E}_{\text{out}}}_{\substack{\text{Rate of net energy transfer} \\ \text{by heat, work, and mass}}} = \underbrace{\Delta \dot{E}_{\text{system}}}_{\substack{\text{Rate of change in internal, kinetic,} \\ \text{potential, etc. energies}}} \stackrel{\cong 0 \text{ (steady)}}{=} 0$$

$$\dot{E}_{\text{in}} = \dot{E}_{\text{out}}$$

$$\dot{m} \left(h_1 + \frac{V_1^2}{2} \right) = \dot{m} \left(h_2 + \frac{V_2^2}{2} \right) \quad (\text{since } \dot{W} \cong \dot{Q} \cong \Delta p e \cong 0)$$

$$h_1 - h_2 = \left(\frac{V_2^2 - V_1^2}{2} \right)$$

Solving for the exit velocity and substituting,

$$h_1 - h_2 = \left(\frac{V_2^2 - V_1^2}{2} \right)$$

$$V_2 = \left[V_1^2 + 2(h_1 - h_2) \right]^{0.5} = \left[(550 \text{ m/s})^2 + 2(2711.4 - 2845.7) \text{ kJ/kg} \left(\frac{1000 \text{ m}^2/\text{s}^2}{1 \text{ kJ/kg}} \right) \right]^{0.5}$$

$$= \mathbf{184.1 \text{ m/s}}$$

7-47E Steam expands in an adiabatic turbine. The maximum amount of work that can be done by the turbine is to be determined.

Assumptions 1 This is a steady-flow process since there is no change with time. **2** Kinetic and potential energy changes are negligible. **3** The device is adiabatic and thus heat transfer is negligible.

Analysis The work output of an adiabatic turbine is maximum when the expansion process is reversible. For the reversible adiabatic process we have $s_2 = s_1$. From the steam tables (Tables A-4E through A-6E),

$$\left. \begin{array}{l} P_1 = 800 \text{ psia} \\ T_1 = 900^\circ\text{F} \end{array} \right\} \begin{array}{l} h_1 = 1456.0 \text{ Btu/lbm} \\ s_1 = 1.6413 \text{ Btu/lbm}\cdot\text{R} \end{array}$$

$$\left. \begin{array}{l} P_2 = 40 \text{ psia} \\ s_2 = s_1 \end{array} \right\} \begin{array}{l} x_2 = \frac{s_2 - s_f}{s_{fg}} = \frac{1.6413 - 0.39213}{1.28448} = 0.9725 \\ h_2 = h_f + x_2 h_{fg} = 236.14 + (0.9725)(933.69) = 1144.2 \text{ Btu/lbm} \end{array}$$

There is only one inlet and one exit, and thus $\dot{m}_1 = \dot{m}_2 = \dot{m}$. We take the turbine as the system, which is a control volume since mass crosses the boundary. The energy balance for this steady-flow system can be expressed in the rate form as

$$\underbrace{\dot{E}_{\text{in}} - \dot{E}_{\text{out}}}_{\text{Rate of net energy transfer by heat, work, and mass}} = \underbrace{\Delta \dot{E}_{\text{system}}}_{\text{Rate of change in internal, kinetic, potential, etc. energies}} \stackrel{\approx 0 \text{ (steady)}}{=} 0$$

$$\dot{E}_{\text{in}} = \dot{E}_{\text{out}}$$

$$\dot{m}h_1 = \dot{W}_{\text{out}} + \dot{m}h_2$$

$$\dot{W}_{\text{out}} = \dot{m}(h_1 - h_2)$$

Dividing by mass flow rate and substituting,

$$w_{\text{out}} = h_1 - h_2 = 1456.0 - 1144.2 = \mathbf{311.8 \text{ Btu/lbm}}$$

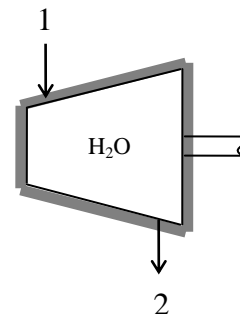



7-48E Problem 7-47E is reconsidered. The work done by the steam is to be calculated and plotted as a function of final pressure as the pressure varies from 800 psia to 40 psia. Also the effect of varying the turbine inlet temperature from the saturation temperature at 800 psia to 900°F on the turbine work is to be investigated.

Analysis The problem is solved using EES, and the results are tabulated and plotted below.

"Knowns:"

P_1 = 800 [psia]
 T_1 = 900 [F]
 P_2 = 40 [psia]
 T_sat_P_1= temperature(Fluid\$,P=P_1,x=1.0)
 Fluid\$='Steam_IAPWS'

"Analysis: "

" Treat the turbine as a steady-flow control volume, with no heat transfer in, neglect changes in KE and PE of the Steam."
 "The isentropic work is determined from the steady-flow energy equation written per unit mass:"

e_in - e_out = DELTAe_sys
 E_out = Work_out+h_2 "[Btu/lbm]"
 e_in = h_1 "[Btu/lbm]"
 DELTAe_sys = 0 "[Btu/lbm]"
 h_1 = enthalpy(Fluid\$,P=P_1,T=T_1)
 s_1 = entropy(Fluid\$,P=P_1,T=T_1)

"The process is reversible and adiabatic or isentropic. Then P_2 and s_2 specify state 2."
 s_2 = s_1 "[Btu/lbm-R]"
 h_2 = enthalpy(Fluid\$,P=P_2,s=s_2)
 T_2_isen=temperature(Fluid\$,P=P_2,s=s_2)

T ₁ [F]	Work _{out} [Btu/lbm]
520	219.3
560	229.6
600	239.1
650	250.7
690	260
730	269.4
770	279
820	291.3
860	301.5
900	311.9

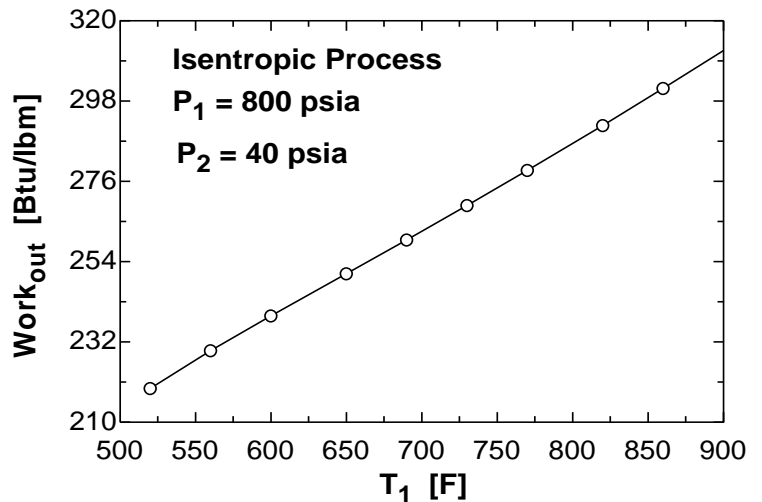
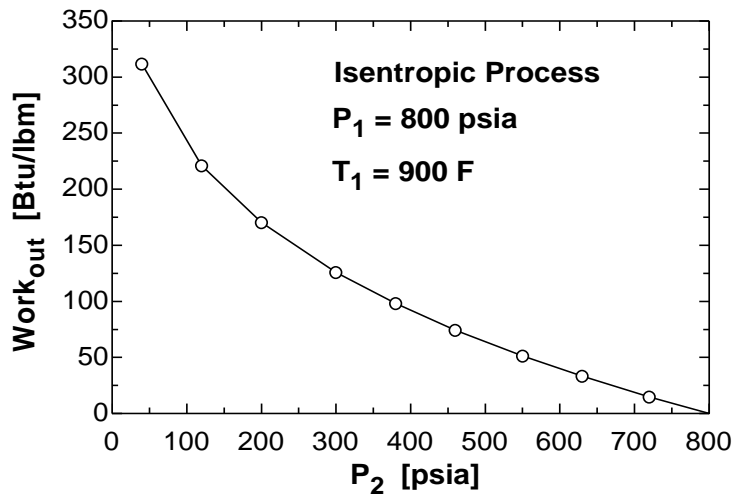

7-49 Steam is expanded in an isentropic turbine. The work produced is to be determined.

Assumptions 1 This is a steady-flow process since there is no change with time. **2** The process is isentropic (i.e., reversible-adiabatic).

Analysis There is one inlet and two exits. We take the turbine as the system, which is a control volume since mass crosses the boundary. The energy balance for this steady-flow system can be expressed in the rate form as

$$\underbrace{\dot{E}_{\text{in}} - \dot{E}_{\text{out}}}_{\text{Rate of net energy transfer by heat, work, and mass}} = \underbrace{\dot{\Delta E}_{\text{system}}}_{\text{Rate of change in internal, kinetic, potential, etc. energies}} \stackrel{\text{no (steady)}}{=} 0$$

$$\dot{E}_{\text{in}} = \dot{E}_{\text{out}}$$

$$\dot{m}_1 h_1 = \dot{m}_2 h_2 + \dot{m}_3 h_3 + \dot{W}_{\text{out}}$$

$$\dot{W}_{\text{out}} = \dot{m}_1 h_1 - \dot{m}_2 h_2 - \dot{m}_3 h_3$$

From a mass balance,

$$\dot{m}_2 = 0.05 \dot{m}_1 = (0.05)(5 \text{ kg/s}) = 0.25 \text{ kg/s}$$

$$\dot{m}_3 = 0.95 \dot{m}_1 = (0.95)(5 \text{ kg/s}) = 4.75 \text{ kg/s}$$

Noting that the expansion process is isentropic, the enthalpies at three states are determined as follows:

$$\left. \begin{array}{l} P_3 = 50 \text{ kPa} \\ T_3 = 100^\circ\text{C} \end{array} \right\} \begin{array}{l} h_3 = 2682.4 \text{ kJ/kg} \\ s_3 = 7.6953 \text{ kJ/kg} \cdot \text{K} \end{array} \quad (\text{Table A - 6})$$

$$\left. \begin{array}{l} P_1 = 3 \text{ MPa} \\ s_1 = s_3 = 7.6953 \text{ kJ/kg} \cdot \text{K} \end{array} \right\} h_1 = 3851.2 \text{ kJ/kg} \quad (\text{Table A - 6})$$

$$\left. \begin{array}{l} P_2 = 500 \text{ kPa} \\ s_2 = s_3 = 7.6953 \text{ kJ/kg} \cdot \text{K} \end{array} \right\} h_2 = 3206.5 \text{ kJ/kg} \quad (\text{Table A - 6})$$

Substituting,

$$\begin{aligned} \dot{W}_{\text{out}} &= \dot{m}_1 h_1 - \dot{m}_2 h_2 - \dot{m}_3 h_3 \\ &= (2 \text{ kg/s})(3851.2 \text{ kJ/kg}) - (0.1 \text{ kg/s})(3206.5 \text{ kJ/kg}) - (1.9 \text{ kg/s})(2682.4 \text{ kJ/kg}) \\ &= \mathbf{2285 \text{ kW}} \end{aligned}$$

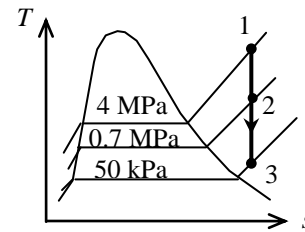
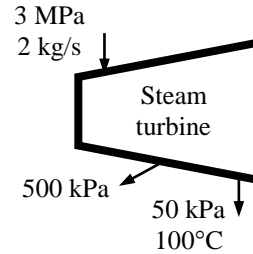

7-50 Water is compressed in a closed system during which the entropy remains constant. The final temperature and the work required are to be determined.

Analysis The initial state is superheated vapor and thus

$$\left. \begin{array}{l} P_1 = 70 \text{ kPa} \\ T_1 = 100^\circ\text{C} \end{array} \right\} \begin{array}{l} u_1 = 2509.4 \text{ kJ/kg} \\ s_1 = 7.5344 \text{ kJ/kg} \cdot \text{K} \end{array} \quad (\text{Table A - 6})$$

The entropy is constant during the process. The properties at the exit state are

$$\left. \begin{array}{l} P_2 = 4000 \text{ kPa} \\ s_2 = s_1 = 7.5344 \text{ kJ/kg} \cdot \text{K} \end{array} \right\} \begin{array}{l} u_2 = 3396.5 \text{ kJ/kg} \\ T_2 = \mathbf{664^\circ\text{C}} \end{array} \quad (\text{Table A - 6})$$

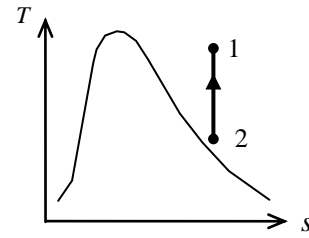

To determine the work done, we take the contents of the cylinder as the system. This is a closed system since no mass enters or leaves. The energy balance for this stationary closed system can be expressed as

$$\underbrace{E_{\text{in}} - E_{\text{out}}}_{\substack{\text{Net energy transfer} \\ \text{by heat, work, and mass}}} = \underbrace{\Delta E_{\text{system}}}_{\substack{\text{Change in internal, kinetic,} \\ \text{potential, etc. energies}}} \\ w_{\text{in}} = \Delta u = u_2 - u_1 \quad (\text{since } Q = \text{KE} = \text{PE} = 0)$$

Substituting,

$$w_{\text{in}} = u_2 - u_1 = (3396.5 - 2509.4) \text{ kJ/kg} = \mathbf{887.1 \text{ kJ/kg}}$$

7-51 Refrigerant-134a is expanded in a closed system during which the entropy remains constant. The heat transfer and the work production are to be determined.

Analysis The initial state is superheated vapor and thus

$$\left. \begin{array}{l} P_1 = 800 \text{ kPa} \\ T_1 = 50^\circ\text{C} \end{array} \right\} \begin{array}{l} u_1 = 263.87 \text{ kJ/kg} \\ s_1 = 0.9803 \text{ kJ/kg} \cdot \text{K} \end{array} \quad (\text{Table A - 13})$$

The entropy is constant during the process. The properties at the exit state are

$$\left. \begin{array}{l} P_2 = 140 \text{ kPa} \\ s_2 = s_1 = 0.9803 \text{ kJ/kg} \cdot \text{K} \end{array} \right\} \begin{array}{l} u_2 = 227.77 \text{ kJ/kg} \end{array} \quad (\text{Table A - 13})$$

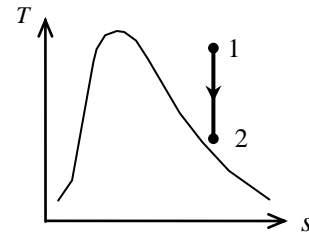

Since the process is isentropic, and thus the heat transfer is zero.

$$Q = \mathbf{0 \text{ kJ}}$$

To determine the work done, we take the contents of the cylinder as the system. This is a closed system since no mass enters or leaves. The energy balance for this stationary closed system can be expressed as

$$\underbrace{E_{\text{in}} - E_{\text{out}}}_{\substack{\text{Net energy transfer} \\ \text{by heat, work, and mass}}} = \underbrace{\Delta E_{\text{system}}}_{\substack{\text{Change in internal, kinetic,} \\ \text{potential, etc. energies}}} \\ -W_{\text{out}} = \Delta U = m(u_2 - u_1) \quad (\text{since } Q = \text{KE} = \text{PE} = 0)$$

Substituting,

$$W_{\text{out}} = m(u_1 - u_2) = (0.7 \text{ kg})(263.87 - 227.77) \text{ kJ/kg} = \mathbf{25.3 \text{ kJ}}$$

7-52 Water vapor is expanded adiabatically in a piston-cylinder device. The entropy change is to be determined and it is to be discussed if this process is realistic.

Analysis (a) The properties at the initial state are

$$\left. \begin{array}{l} P_1 = 600 \text{ kPa} \\ x_1 = 1 \end{array} \right\} \begin{array}{l} u_1 = 2566.8 \text{ kJ/kg} \\ s_1 = 6.7593 \text{ kJ/kg} \cdot \text{K} \end{array} \quad (\text{Table A - 5})$$

We take the contents of the cylinder as the system. This is a closed system since no mass enters or leaves. The energy balance for this stationary closed system can be expressed as

$$\underbrace{E_{\text{in}} - E_{\text{out}}}_{\substack{\text{Net energy transfer} \\ \text{by heat, work, and mass}}} = \underbrace{\Delta E_{\text{system}}}_{\substack{\text{Change in internal, kinetic,} \\ \text{potential, etc. energies}}} - W_{\text{out}} = \Delta U = m(u_2 - u_1) \quad (\text{since } Q = \text{KE} = \text{PE} = 0)$$

Solving for the final state internal energy,

$$u_2 = u_1 + \frac{W_{\text{out}}}{m} = 2566.8 \text{ kJ/kg} + \frac{700 \text{ kJ}}{2 \text{ kg}} = 2216.8 \text{ kJ/kg}$$

The entropy at the final state is (from Table A-5)

$$\left. \begin{array}{l} P_2 = 100 \text{ kPa} \\ u_2 = 2216.8 \text{ kJ/kg} \end{array} \right\} \begin{array}{l} x_2 = \frac{u_2 - u_f}{u_{fg}} = \frac{2216.8 - 417.40}{2088.2} = 0.8617 \\ s_2 = s_f + x s_{fg} = 1.3028 + 0.8617 \times 6.0562 = 6.5215 \text{ kJ/kg} \cdot \text{K} \end{array}$$

The entropy change is

$$\Delta s = s_2 - s_1 = 6.5215 - 6.7593 = \mathbf{-0.238 \text{ kJ/kg} \cdot \text{K}}$$

(b) The process is not realistic since entropy cannot decrease during an adiabatic process. In the limiting case of a reversible (and adiabatic) process, the entropy would remain constant.

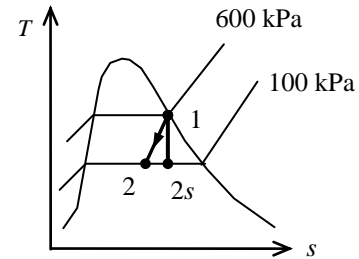

7-53 Steam enters a nozzle at a specified state and leaves at a specified pressure. The process is to be sketched on the T - s diagram and the maximum outlet velocity is to be determined.

Analysis (b) The inlet state properties are

$$\left. \begin{array}{l} P_1 = 6000 \text{ kPa} \\ x_1 = 1 \end{array} \right\} \begin{array}{l} h_1 = 2784.6 \text{ kJ/kg} \\ s_1 = 5.8902 \text{ kJ/kg} \cdot \text{K} \end{array} \quad (\text{Table A - 5})$$

For the maximum velocity at the exit, the entropy will be constant during the process. The exit state enthalpy is (Table A-6)

$$\left. \begin{array}{l} P_2 = 1200 \text{ kPa} \\ s_2 = s_1 = 5.8902 \text{ kJ/kg} \cdot \text{K} \end{array} \right\} \begin{array}{l} x_2 = \frac{s_2 - s_f}{s_{fg}} = \frac{5.8902 - 2.2159}{4.3058} = 0.8533 \\ h_2 = h_f + xh_{fg} = 798.33 + 0.8533 \times 1985.4 = 2492.5 \text{ kJ/kg} \end{array}$$

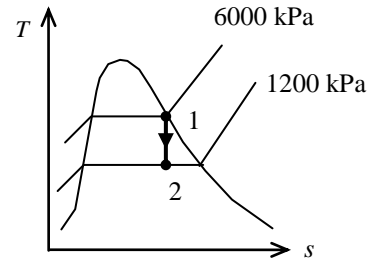

We take the nozzle as the system, which is a control volume since mass crosses the boundary. Noting that one fluid stream enters and leaves the nozzle, the energy balance for this steady-flow system can be expressed in the rate form as

$$\underbrace{\dot{E}_{\text{in}} - \dot{E}_{\text{out}}}_{\text{Rate of net energy transfer by heat, work, and mass}} = \underbrace{\Delta \dot{E}_{\text{system}}}_{\text{Rate of change in internal, kinetic, potential, etc. energies}} \stackrel{\neq 0 \text{ (steady)}}{=} 0$$

$$\dot{E}_{\text{in}} = \dot{E}_{\text{out}}$$

$$\dot{m} \left(h_1 + \frac{V_1^2}{2} \right) = \dot{m} \left(h_2 + \frac{V_2^2}{2} \right) \quad (\text{since } \dot{W} \cong \dot{Q} \cong \Delta p e \cong 0)$$

$$h_1 - h_2 = \left(\frac{V_2^2 - V_1^2}{2} \right)$$

Solving for the exit velocity and substituting,

$$h_1 - h_2 = \left(\frac{V_2^2 - V_1^2}{2} \right)$$

$$V_2 = \left[V_1^2 + 2(h_1 - h_2) \right]^{0.5} = \left[(0 \text{ m/s})^2 + 2(2784.6 - 2492.5) \text{ kJ/kg} \left(\frac{1000 \text{ m}^2/\text{s}^2}{1 \text{ kJ/kg}} \right) \right]^{0.5}$$

$$= \mathbf{764.3 \text{ m/s}}$$

7-54 Heat is added to a pressure cooker that is maintained at a specified pressure. The minimum entropy change of the thermal-energy reservoir supplying this heat is to be determined.

Assumptions 1 Only water vapor escapes through the pressure relief valve.

Analysis According to the conservation of mass principle,

$$\frac{dm_{CV}}{dt} = \sum_{in} \dot{m} - \sum_{out} \dot{m}$$

$$\frac{dm}{dt} = -\dot{m}_{out}$$

An entropy balance adapted to this system becomes

$$\frac{dS_{surr}}{dt} + \frac{d(ms)}{dt} + \dot{m}_{out}s \geq 0$$

When this is combined with the mass balance, it becomes

$$\frac{dS_{surr}}{dt} + \frac{d(ms)}{dt} - s \frac{dm}{dt} \geq 0$$

Multiplying by dt and integrating the result yields

$$\Delta S_{surr} + m_2 s_2 - m_1 s_1 - s_{out}(m_2 - m_1) \geq 0$$

The properties at the initial and final states are (from Table A-5 at $P_1 = 175$ kPa and $P_2 = 150$ kPa)

$$v_1 = v_f + x v_{fg} = 0.001057 + (0.10)(1.0037 - 0.001057) = 0.1013 \text{ m}^3/\text{kg}$$

$$s_1 = s_f + x s_{fg} = 1.4850 + (0.10)(5.6865) = 2.0537 \text{ kJ/kg} \cdot \text{K}$$

$$v_2 = v_f + x v_{fg} = 0.001053 + (0.40)(1.1594 - 0.001053) = 0.4644 \text{ m}^3/\text{kg}$$

$$s_2 = s_f + x s_{fg} = 1.4337 + (0.40)(5.7894) = 3.7494 \text{ kJ/kg} \cdot \text{K}$$

The initial and final masses are

$$m_1 = \frac{V}{v_1} = \frac{0.020 \text{ m}^3}{0.1013 \text{ m}^3/\text{kg}} = 0.1974 \text{ kg}$$

$$m_2 = \frac{V}{v_2} = \frac{0.020 \text{ m}^3}{0.4644 \text{ m}^3/\text{kg}} = 0.04307 \text{ kg}$$

The entropy of escaping water vapor is

$$s_{out} = s_g @ 150 \text{ kPa} = 7.2231 \text{ kJ/kg} \cdot \text{K}$$

Substituting,

$$\Delta S_{surr} + m_2 s_2 - m_1 s_1 - s_{out}(m_2 - m_1) \geq 0$$

$$\Delta S_{surr} + (0.04307)(3.7494) - (0.1974)(2.0537) - (7.2231)(0.04307 - 0.1974) \geq 0$$

$$\Delta S_{surr} + 0.8708 \geq 0$$

The entropy change of the thermal energy reservoir must then satisfy

$$\Delta S_{surr} \geq \mathbf{-0.8708 \text{ kJ/K}}$$

7-55 Heat is added to a pressure cooker that is maintained at a specified pressure. Work is also done on water. The minimum entropy change of the thermal-energy reservoir supplying this heat is to be determined.

Assumptions 1 Only water vapor escapes through the pressure relief valve.

Analysis According to the conservation of mass principle,

$$\frac{dm_{CV}}{dt} = \sum_{in} \dot{m} - \sum_{out} \dot{m}$$

$$\frac{dm}{dt} = -\dot{m}_{out}$$

An entropy balance adapted to this system becomes

$$\frac{dS_{surr}}{dt} + \frac{d(ms)}{dt} + \dot{m}_{out}s \geq 0$$

When this is combined with the mass balance, it becomes

$$\frac{dS_{surr}}{dt} + \frac{d(ms)}{dt} - s \frac{dm}{dt} \geq 0$$

Multiplying by dt and integrating the result yields

$$\Delta S_{surr} + m_2 s_2 - m_1 s_1 - s_{out}(m_2 - m_1) \geq 0$$

Note that work done on the water has no effect on this entropy balance since work transfer does not involve any entropy transfer. The properties at the initial and final states are (from Table A-5 at $P_1 = 175$ kPa and $P_2 = 150$ kPa)

$$v_1 = v_f + x v_{fg} = 0.001057 + (0.10)(1.0037 - 0.001057) = 0.1013 \text{ m}^3/\text{kg}$$

$$s_1 = s_f + x s_{fg} = 1.4850 + (0.10)(5.6865) = 2.0537 \text{ kJ/kg} \cdot \text{K}$$

$$v_2 = v_f + x v_{fg} = 0.001053 + (0.40)(1.1594 - 0.001053) = 0.4644 \text{ m}^3/\text{kg}$$

$$s_2 = s_f + x s_{fg} = 1.4337 + (0.40)(5.7894) = 3.7494 \text{ kJ/kg} \cdot \text{K}$$

The initial and final masses are

$$m_1 = \frac{v}{v_1} = \frac{0.020 \text{ m}^3}{0.1013 \text{ m}^3/\text{kg}} = 0.1974 \text{ kg}$$

$$m_2 = \frac{v}{v_2} = \frac{0.020 \text{ m}^3}{0.4644 \text{ m}^3/\text{kg}} = 0.04307 \text{ kg}$$

The entropy of escaping water vapor is

$$s_{out} = s_g @ 150 \text{ kPa} = 7.2231 \text{ kJ/kg} \cdot \text{K}$$

Substituting,

$$\Delta S_{surr} + m_2 s_2 - m_1 s_1 - s_{out}(m_2 - m_1) \geq 0$$

$$\Delta S_{surr} + (0.04307)(3.7494) - (0.1974)(2.0537) - (7.2231)(0.04307 - 0.1974) \geq 0$$

$$\Delta S_{surr} + 0.8708 \geq 0$$

The entropy change of the thermal energy reservoir must then satisfy

$$\Delta S_{surr} \geq \mathbf{-0.8708 \text{ kJ/K}}$$

7-56 A cylinder is initially filled with saturated water vapor mixture at a specified temperature. Steam undergoes a reversible heat addition and an isentropic process. The processes are to be sketched and heat transfer for the first process and work done during the second process are to be determined.

Assumptions 1 The kinetic and potential energy changes are negligible. **2** The thermal energy stored in the cylinder itself is negligible. **3** Both processes are reversible.

Analysis (b) From the steam tables (Tables A-4 through A-6),

$$\left. \begin{array}{l} T_1 = 100^\circ\text{C} \\ x = 0.5 \end{array} \right\} h_1 = h_f + xh_{fg} = 419.17 + (0.5)(2256.4) = 1547.4 \text{ kJ/kg}$$

$$\left. \begin{array}{l} T_2 = 100^\circ\text{C} \\ x_2 = 1 \end{array} \right\} \begin{array}{l} h_2 = h_g = 2675.6 \text{ kJ/kg} \\ u_2 = u_g = 2506.0 \text{ kJ/kg} \\ s_2 = s_g = 7.3542 \text{ kJ/kg}\cdot\text{K} \end{array}$$

$$\left. \begin{array}{l} P_3 = 15 \text{ kPa} \\ s_3 = s_2 \end{array} \right\} u_3 = 2247.9 \text{ kJ/kg}$$

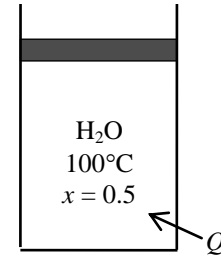

We take the contents of the cylinder as the system. This is a closed system since no mass enters or leaves. The energy balance for this closed system can be expressed as

$$\underbrace{E_{\text{in}} - E_{\text{out}}}_{\substack{\text{Net energy transfer} \\ \text{by heat, work, and mass}}} = \underbrace{\Delta E_{\text{system}}}_{\substack{\text{Change in internal, kinetic,} \\ \text{potential, etc. energies}}}$$

$$Q_{\text{in}} - W_{\text{b,out}} = \Delta U = m(u_2 - u_1)$$

For process 1-2, it reduces to

$$Q_{12,\text{in}} = m(h_2 - h_1) = (5 \text{ kg})(2675.6 - 1547.4) \text{ kJ/kg} = \mathbf{5641 \text{ kJ}}$$

(c) For process 2-3, it reduces to

$$W_{23,\text{b,out}} = m(u_2 - u_3) = (5 \text{ kg})(2506.0 - 2247.9) \text{ kJ/kg} = \mathbf{1291 \text{ kJ}}$$

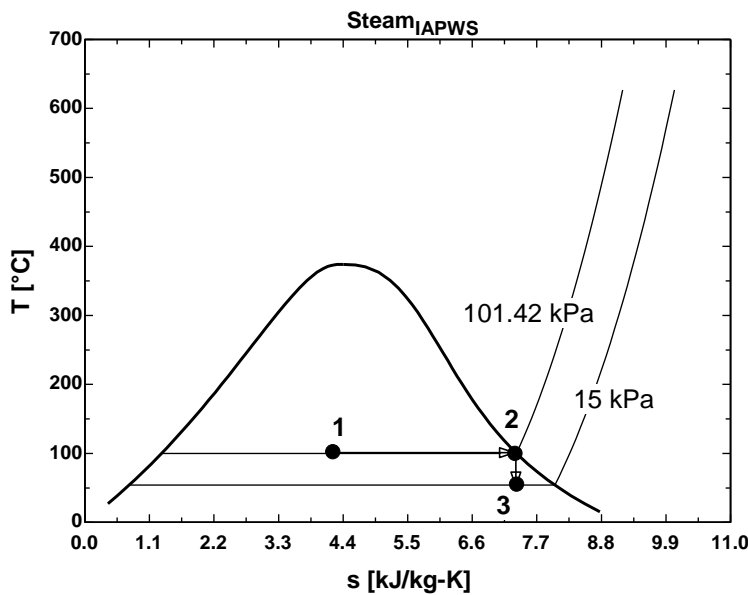

7-57E An insulated rigid can initially contains R-134a at a specified state. A crack develops, and refrigerant escapes slowly. The final mass in the can is to be determined when the pressure inside drops to a specified value.

Assumptions **1** The can is well-insulated and thus heat transfer is negligible. **2** The refrigerant that remains in the can underwent a reversible adiabatic process.

Analysis Noting that for a reversible adiabatic (i.e., isentropic) process, $s_1 = s_2$, the properties of the refrigerant in the can are (Tables A-11E through A-13E)

$$\left. \begin{array}{l} P_1 = 90 \text{ psia} \\ T_1 = 30^\circ\text{F} \end{array} \right\} s_1 \cong s_{f@30^\circ\text{F}} = 0.04750 \text{ Btu/lbm}\cdot\text{R}$$

$$\left. \begin{array}{l} P_2 = 20 \text{ psia} \\ s_2 = s_1 \end{array} \right\} x_2 = \frac{s_2 - s_f}{s_{fg}} = \frac{0.04750 - 0.02603}{0.1997} = 0.1075$$

$$\nu_2 = \nu_f + x_2 \nu_{fg} = 0.01181 + (0.1075)(2.2781 - 0.01181) = 0.2555 \text{ ft}^3/\text{lbm}$$

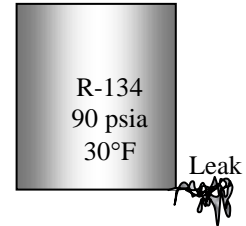

Thus the final mass of the refrigerant in the can is

$$m = \frac{\nu}{\nu_2} = \frac{0.55 \text{ ft}^3}{0.2555 \text{ ft}^3/\text{lbm}} = \mathbf{2.15 \text{ lbm}}$$

7-58E An electric windshield defroster used to remove ice is considered. The electrical energy required and the minimum temperature of the defroster are to be determined.

Assumptions No heat is transferred from the defroster or ice to the surroundings.

Analysis The conservation of mass principle is

$$\frac{dm_{cv}}{dt} = \sum_{in} \dot{m} - \sum_{out} \dot{m}$$

which reduces to

$$\frac{dm_{cv}}{dt} = -\dot{m}_{out}$$

while the first law reduces to

$$-W_{out} = \frac{d(mu)_{cv}}{dt} + \dot{m}_{out}h_{out}$$

Combining these two expressions yield

$$W_{out} = h_{out} \frac{dm_{cv}}{dt} - \frac{d(mu)_{cv}}{dt}$$

When this is multiplied by dt and integrated from time when the ice layer is present until it is removed ($m = 0$) gives

$$W_{out} = h_{out}(-m_i) + (mu)_i$$

The original mass of the ice layer is

$$m_i = \frac{V}{\nu} = \frac{tA}{\nu}$$

The work required per unit of windshield area is then

$$\frac{W_{out}}{A} = \frac{t}{\nu} (u_i - h_{out}) = \frac{t}{\nu} (u_i - u_f) = \frac{t}{\nu} u_{if} = \frac{(0.25/12) \text{ ft}}{0.01602 \text{ ft}^3/\text{lbm}} (-144 \text{ Btu/lbm}) = -187.3 \text{ Btu/ft}^2$$

That is,

$$W_{in} = \mathbf{187.3 \text{ Btu/ft}^2}$$

The second law as stated by Clausius tells us that the temperature of the defroster cannot be lower than the temperature of the ice being melted. Then,

$$T_{min} = \mathbf{32^\circ\text{F}}$$

Entropy Change of Incompressible Substances

7-59C No, because entropy is not a conserved property.

7-60 A hot copper block is dropped into water in an insulated tank. The final equilibrium temperature of the tank and the total entropy change are to be determined.

Assumptions 1 Both the water and the copper block are incompressible substances with constant specific heats at room temperature. **2** The system is stationary and thus the kinetic and potential energies are negligible. **3** The tank is well-insulated and thus there is no heat transfer.

Properties The density and specific heat of water at 25°C are $\rho = 997 \text{ kg/m}^3$ and $c_p = 4.18 \text{ kJ/kg}\cdot^\circ\text{C}$. The specific heat of copper at 27°C is $c_p = 0.386 \text{ kJ/kg}\cdot^\circ\text{C}$ (Table A-3).

Analysis We take the entire contents of the tank, water + copper block, as the *system*. This is a *closed system* since no mass crosses the system boundary during the process. The energy balance for this system can be expressed as

$$\underbrace{E_{\text{in}} - E_{\text{out}}}_{\substack{\text{Net energy transfer} \\ \text{by heat, work, and mass}}} = \underbrace{\Delta E_{\text{system}}}_{\substack{\text{Change in internal, kinetic,} \\ \text{potential, etc. energies}}}$$

$$0 = \Delta U$$

or,

$$\Delta U_{\text{Cu}} + \Delta U_{\text{water}} = 0$$

$$[mc(T_2 - T_1)]_{\text{Cu}} + [mc(T_2 - T_1)]_{\text{water}} = 0$$

where

$$m_{\text{water}} = \rho V = (997 \text{ kg/m}^3)(0.090 \text{ m}^3) = 89.73 \text{ kg}$$

Using specific heat values for copper and liquid water at room temperature and substituting,

$$(50 \text{ kg})(0.386 \text{ kJ/kg}\cdot^\circ\text{C})(T_2 - 140)^\circ\text{C} + (89.73 \text{ kg})(4.18 \text{ kJ/kg}\cdot^\circ\text{C})(T_2 - 10)^\circ\text{C} = 0$$

$$T_2 = \mathbf{16.4^\circ\text{C}} = 289.4 \text{ K}$$

The entropy generated during this process is determined from

$$\Delta S_{\text{copper}} = mc_{\text{avg}} \ln\left(\frac{T_2}{T_1}\right) = (50 \text{ kg})(0.386 \text{ kJ/kg}\cdot\text{K}) \ln\left(\frac{289.4 \text{ K}}{413 \text{ K}}\right) = -6.864 \text{ kJ/K}$$

$$\Delta S_{\text{water}} = mc_{\text{avg}} \ln\left(\frac{T_2}{T_1}\right) = (89.73 \text{ kg})(4.18 \text{ kJ/kg}\cdot\text{K}) \ln\left(\frac{289.4 \text{ K}}{283 \text{ K}}\right) = 8.388 \text{ kJ/K}$$

Thus,

$$\Delta S_{\text{total}} = \Delta S_{\text{copper}} + \Delta S_{\text{water}} = -6.864 + 8.388 = \mathbf{1.52 \text{ kJ/K}}$$

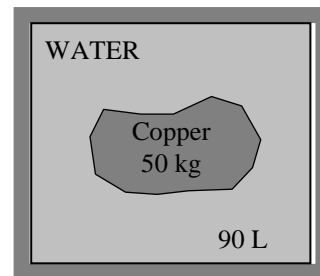

7-61 Computer chips are cooled by placing them in saturated liquid R-134a. The entropy changes of the chips, R-134a, and the entire system are to be determined.

Assumptions 1 The system is stationary and thus the kinetic and potential energy changes are zero. **2** There are no work interactions involved. **3** There is no heat transfer between the system and the surroundings.

Analysis (a) The energy balance for this system can be expressed as

$$\underbrace{E_{\text{in}} - E_{\text{out}}}_{\substack{\text{Net energy transfer} \\ \text{by heat, work, and mass}}} = \underbrace{\Delta E_{\text{system}}}_{\substack{\text{Change in internal, kinetic,} \\ \text{potential, etc. energies}}}$$

$$0 = \Delta U = [m(u_2 - u_1)]_{\text{chips}} + [m(u_2 - u_1)]_{\text{R-134a}}$$

$$[m(u_1 - u_2)]_{\text{chips}} = [m(u_2 - u_1)]_{\text{R-134a}}$$

The heat released by the chips is

$$Q_{\text{chips}} = mc(T_1 - T_2) = (0.010 \text{ kg})(0.3 \text{ kJ/kg} \cdot \text{K})[20 - (-40)] \text{ K} = 0.18 \text{ kJ}$$

The mass of the refrigerant vaporized during this heat exchange process is

$$m_{g,2} = \frac{Q_{\text{R-134a}}}{u_g - u_f} = \frac{Q_{\text{R-134a}}}{u_{fg@-40^\circ\text{C}}} = \frac{0.18 \text{ kJ}}{207.40 \text{ kJ/kg}} = 0.0008679 \text{ kg}$$

Only a small fraction of R-134a is vaporized during the process. Therefore, the temperature of R-134a remains constant during the process. The change in the entropy of the R-134a is (at -40°F from Table A-11)

$$\begin{aligned} \Delta S_{\text{R-134a}} &= m_{g,2}s_{g,2} + m_{f,2}s_{f,2} - m_{f,1}s_{f,1} \\ &= (0.0008679)(0.96866) + (0.005 - 0.0008679)(0) - (0.005)(0) \\ &= \mathbf{0.000841 \text{ kJ/K}} \end{aligned}$$

(b) The entropy change of the chips is

$$\Delta S_{\text{chips}} = mc \ln \frac{T_2}{T_1} = (0.010 \text{ kg})(0.3 \text{ kJ/kg} \cdot \text{K}) \ln \frac{(-40 + 273) \text{ K}}{(20 + 273) \text{ K}} = \mathbf{-0.000687 \text{ kJ/K}}$$

(c) The total entropy change is

$$\Delta S_{\text{total}} = S_{\text{gen}} = \Delta S_{\text{R-134a}} + \Delta S_{\text{chips}} = 0.000841 + (-0.000687) = \mathbf{0.000154 \text{ kJ/K}}$$

The positive result for the total entropy change (i.e., entropy generation) indicates that this process is possible.

7-62 A hot iron block is dropped into water in an insulated tank. The total entropy change during this process is to be determined.

Assumptions 1 Both the water and the iron block are incompressible substances with constant specific heats at room temperature. **2** The system is stationary and thus the kinetic and potential energies are negligible. **3** The tank is well-insulated and thus there is no heat transfer. **4** The water that evaporates, condenses back.

Properties The specific heat of water at 25°C is $c_p = 4.18 \text{ kJ/kg} \cdot \text{°C}$. The specific heat of iron at room temperature is $c_p = 0.45 \text{ kJ/kg} \cdot \text{°C}$ (Table A-3).

Analysis We take the entire contents of the tank, water + iron block, as the *system*. This is a *closed system* since no mass crosses the system boundary during the process. The energy balance for this system can be expressed as

$$\underbrace{E_{\text{in}} - E_{\text{out}}}_{\substack{\text{Net energy transfer} \\ \text{by heat, work, and mass}}} = \underbrace{\Delta E_{\text{system}}}_{\substack{\text{Change in internal, kinetic,} \\ \text{potential, etc. energies}}} \\ 0 = \Delta U$$

or,

$$\Delta U_{\text{iron}} + \Delta U_{\text{water}} = 0$$

$$[mc(T_2 - T_1)]_{\text{iron}} + [mc(T_2 - T_1)]_{\text{water}} = 0$$

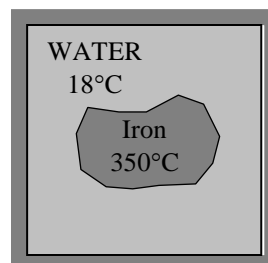

Substituting,

$$(25 \text{ kg})(0.45 \text{ kJ/kg} \cdot \text{K})(T_2 - 350^\circ\text{C}) + (100 \text{ kg})(4.18 \text{ kJ/kg} \cdot \text{K})(T_2 - 18^\circ\text{C}) = 0$$

$$T_2 = \mathbf{26.7^\circ\text{C}}$$

The entropy generated during this process is determined from

$$\Delta S_{\text{iron}} = mc_{\text{avg}} \ln\left(\frac{T_2}{T_1}\right) = (25 \text{ kg})(0.45 \text{ kJ/kg} \cdot \text{K}) \ln\left(\frac{299.7 \text{ K}}{623 \text{ K}}\right) = -8.232 \text{ kJ/K}$$

$$\Delta S_{\text{water}} = mc_{\text{avg}} \ln\left(\frac{T_2}{T_1}\right) = (100 \text{ kg})(4.18 \text{ kJ/kg} \cdot \text{K}) \ln\left(\frac{299.7 \text{ K}}{291 \text{ K}}\right) = 12.314 \text{ kJ/K}$$

Thus,

$$S_{\text{gen}} = \Delta S_{\text{total}} = \Delta S_{\text{iron}} + \Delta S_{\text{water}} = -8.232 + 12.314 = \mathbf{4.08 \text{ kJ/K}}$$

Discussion The results can be improved somewhat by using specific heats at average temperature.

7-63 An aluminum block is brought into contact with an iron block in an insulated enclosure. The final equilibrium temperature and the total entropy change for this process are to be determined.

Assumptions 1 Both the aluminum and the iron block are incompressible substances with constant specific heats. **2** The system is stationary and thus the kinetic and potential energies are negligible. **3** The system is well-insulated and thus there is no heat transfer.

Properties The specific heat of aluminum at the anticipated average temperature of 400 K is $c_p = 0.949 \text{ kJ/kg}\cdot^\circ\text{C}$. The specific heat of iron at room temperature (the only value available in the tables) is $c_p = 0.45 \text{ kJ/kg}\cdot^\circ\text{C}$ (Table A-3).

Analysis We take the iron+aluminum blocks as the system, which is a closed system. The energy balance for this system can be expressed as

$$\underbrace{E_{\text{in}} - E_{\text{out}}}_{\substack{\text{Net energy transfer} \\ \text{by heat, work, and mass}}} = \underbrace{\Delta E_{\text{system}}}_{\substack{\text{Change in internal, kinetic,} \\ \text{potential, etc. energies}}} \\ 0 = \Delta U$$

Iron 40 kg 60°C	Aluminum 30 kg 140°C
-----------------------	----------------------------

or,

$$\Delta U_{\text{alum}} + \Delta U_{\text{iron}} = 0 \\ [mc(T_2 - T_1)]_{\text{alum}} + [mc(T_2 - T_1)]_{\text{iron}} = 0$$

Substituting,

$$(30 \text{ kg})(0.949 \text{ kJ/kg}\cdot\text{K})(T_2 - 140^\circ\text{C}) + (40 \text{ kg})(0.45 \text{ kJ/kg}\cdot\text{K})(T_2 - 60^\circ\text{C}) = 0 \\ T_2 = \mathbf{109^\circ\text{C}} = 382 \text{ K}$$

The total entropy change for this process is determined from

$$\Delta S_{\text{iron}} = mc_{\text{avg}} \ln\left(\frac{T_2}{T_1}\right) = (40 \text{ kg})(0.45 \text{ kJ/kg}\cdot\text{K}) \ln\left(\frac{382 \text{ K}}{333 \text{ K}}\right) = 2.472 \text{ kJ/K} \\ \Delta S_{\text{alum}} = mc_{\text{avg}} \ln\left(\frac{T_2}{T_1}\right) = (30 \text{ kg})(0.949 \text{ kJ/kg}\cdot\text{K}) \ln\left(\frac{382 \text{ K}}{413 \text{ K}}\right) = -2.221 \text{ kJ/K}$$

Thus,

$$\Delta S_{\text{total}} = \Delta S_{\text{iron}} + \Delta S_{\text{alum}} = 2.472 - 2.221 = \mathbf{0.251 \text{ kJ/K}}$$



7-64 Problem 7-63 is reconsidered. The effect of the mass of the iron block on the final equilibrium temperature and the total entropy change for the process is to be studied. The mass of the iron is to vary from 10 to 100 kg. The equilibrium temperature and the total entropy change are to be plotted as a function of iron mass.

Analysis The problem is solved using EES, and the results are tabulated and plotted below.

"Knowns:"

$$T_{1_iron} = 60 \text{ [C]}$$

$$m_{iron} = 40 \text{ [kg]}$$

$$T_{1_al} = 140 \text{ [C]}$$

$$m_{al} = 30 \text{ [kg]}$$

$$C_{al} = 0.949 \text{ [kJ/kg-K]} \text{ "From Table A-3 at the anticipated average temperature of 450 K."}$$

$$C_{iron} = 0.45 \text{ [kJ/kg-K]} \text{ "From Table A-3 at room temperature, the only value available."}$$

"Analysis:"

" Treat the iron plus aluminum as a closed system, with no heat transfer in, no work out, neglect changes in KE and PE of the system. "

"The final temperature is found from the energy balance."

$$E_{in} - E_{out} = \Delta E_{sys}$$

$$E_{out} = 0$$

$$E_{in} = 0$$

$$\Delta E_{sys} = m_{iron} \Delta u_{iron} + m_{al} \Delta u_{al}$$

$$\Delta u_{iron} = C_{iron} (T_2 - T_1)_{iron}$$

$$\Delta u_{al} = C_{al} (T_2 - T_1)_{al}$$

"the iron and aluminum reach thermal equilibrium:"

$$T_2_{iron} = T_2$$

$$T_2_{al} = T_2$$

$$\Delta S_{iron} = m_{iron} C_{iron} \ln\left(\frac{T_2 + 273}{T_1 + 273}\right)_{iron}$$

$$\Delta S_{al} = m_{al} C_{al} \ln\left(\frac{T_2 + 273}{T_1 + 273}\right)_{al}$$

$$\Delta S_{total} = \Delta S_{iron} + \Delta S_{al}$$

ΔS_{total} [kJ/kg]	m_{iron} [kg]	T_2 [C]
0.08547	10	129.1
0.1525	20	120.8
0.2066	30	114.3
0.2511	40	109
0.2883	50	104.7
0.32	60	101.1
0.3472	70	97.98
0.3709	80	95.33
0.3916	90	93.02
0.41	100	91

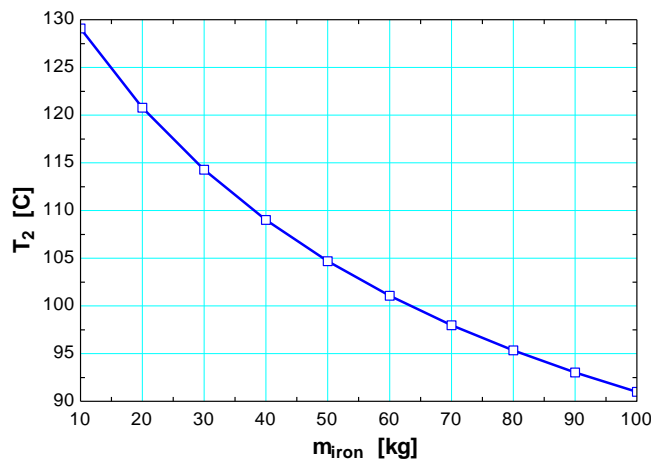
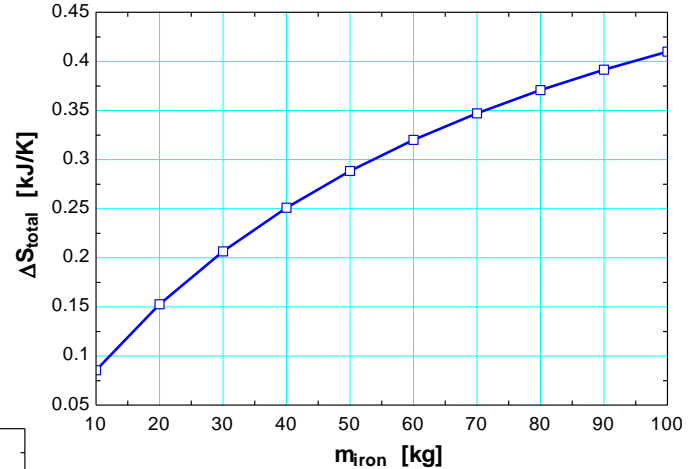

7-65 An iron block and a copper block are dropped into a large lake. The total amount of entropy change when both blocks cool to the lake temperature is to be determined.

Assumptions 1 The water, the iron block and the copper block are incompressible substances with constant specific heats at room temperature. **2** Kinetic and potential energies are negligible.

Properties The specific heats of iron and copper at room temperature are $c_{\text{iron}} = 0.45 \text{ kJ/kg} \cdot ^\circ\text{C}$ and $c_{\text{copper}} = 0.386 \text{ kJ/kg} \cdot ^\circ\text{C}$ (Table A-3).

Analysis The thermal-energy capacity of the lake is very large, and thus the temperatures of both the iron and the copper blocks will drop to the lake temperature (15°C) when the thermal equilibrium is established. Then the entropy changes of the blocks become

$$\Delta S_{\text{iron}} = mc_{\text{avg}} \ln\left(\frac{T_2}{T_1}\right) = (30 \text{ kg})(0.45 \text{ kJ/kg} \cdot \text{K}) \ln\left(\frac{288 \text{ K}}{353 \text{ K}}\right) = -2.746 \text{ kJ/K}$$

$$\Delta S_{\text{copper}} = mc_{\text{avg}} \ln\left(\frac{T_2}{T_1}\right) = (40 \text{ kg})(0.386 \text{ kJ/kg} \cdot \text{K}) \ln\left(\frac{288 \text{ K}}{353 \text{ K}}\right) = -3.141 \text{ kJ/K}$$

We take both the iron and the copper blocks, as the *system*. This is a *closed system* since no mass crosses the system boundary during the process. The energy balance for this system can be expressed as

$$\underbrace{E_{\text{in}} - E_{\text{out}}}_{\substack{\text{Net energy transfer} \\ \text{by heat, work, and mass}}} = \underbrace{\Delta E_{\text{system}}}_{\substack{\text{Change in internal, kinetic,} \\ \text{potential, etc. energies}}}$$

$$-Q_{\text{out}} = \Delta U = \Delta U_{\text{iron}} + \Delta U_{\text{copper}}$$

or,

$$Q_{\text{out}} = [mc(T_1 - T_2)]_{\text{iron}} + [mc(T_1 - T_2)]_{\text{copper}}$$

Substituting,

$$Q_{\text{out}} = (30 \text{ kg})(0.45 \text{ kJ/kg} \cdot \text{K})(353 - 288) \text{ K} + (40 \text{ kg})(0.386 \text{ kJ/kg} \cdot \text{K})(353 - 288) \text{ K}$$

$$= 1881 \text{ kJ}$$

Thus,

$$\Delta S_{\text{lake}} = \frac{Q_{\text{lake, in}}}{T_{\text{lake}}} = \frac{1881 \text{ kJ}}{288 \text{ K}} = 6.528 \text{ kJ/K}$$

Then the total entropy change for this process is

$$\Delta S_{\text{total}} = \Delta S_{\text{iron}} + \Delta S_{\text{copper}} + \Delta S_{\text{lake}} = (-2.746) + (-3.141) + 6.528 = \mathbf{0.642 \text{ kJ/K}}$$

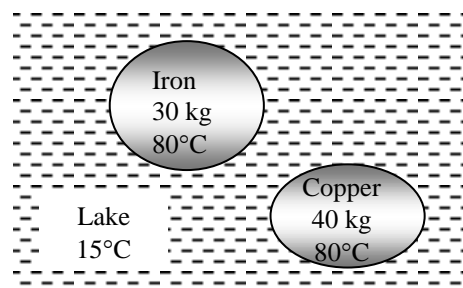

7-66 An adiabatic pump is used to compress saturated liquid water in a reversible manner. The work input is to be determined by different approaches.

Assumptions **1** Steady operating conditions exist. **2** Kinetic and potential energy changes are negligible. **3** Heat transfer to or from the fluid is negligible.

Analysis The properties of water at the inlet and exit of the pump are (Tables A-4 through A-6)

$$\left. \begin{array}{l} P_1 = 10 \text{ kPa} \\ x_1 = 0 \end{array} \right\} \begin{array}{l} h_1 = 191.81 \text{ kJ/kg} \\ s_1 = 0.6492 \text{ kJ/kg} \\ \nu_1 = 0.001010 \text{ m}^3/\text{kg} \end{array}$$

$$\left. \begin{array}{l} P_2 = 15 \text{ MPa} \\ s_2 = s_1 \end{array} \right\} \begin{array}{l} h_2 = 206.90 \text{ kJ/kg} \\ \nu_2 = 0.001004 \text{ m}^3/\text{kg} \end{array}$$

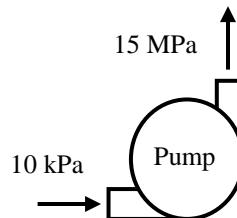

(a) Using the entropy data from the compressed liquid water table

$$w_P = h_2 - h_1 = 206.90 - 191.81 = \mathbf{15.10 \text{ kJ/kg}}$$

(b) Using inlet specific volume and pressure values

$$w_P = \nu_1 (P_2 - P_1) = (0.001010 \text{ m}^3/\text{kg})(15,000 - 10) \text{ kPa} = \mathbf{15.14 \text{ kJ/kg}}$$

$$\text{Error} = \mathbf{0.3\%}$$

(c) Using average specific volume and pressure values

$$w_P = \nu_{\text{avg}} (P_2 - P_1) = \left[1/2(0.001010 + 0.001004) \text{ m}^3/\text{kg} \right] (15,000 - 10) \text{ kPa} = \mathbf{15.10 \text{ kJ/kg}}$$

$$\text{Error} = \mathbf{0\%}$$

Discussion The results show that any of the method may be used to calculate reversible pump work.

Entropy Changes of Ideal Gases

7-67C No. The entropy of an ideal gas depends on the pressure as well as the temperature.

7-68C The entropy of a gas *can* change during an isothermal process since entropy of an ideal gas depends on the pressure as well as the temperature.

7-69C The entropy change relations of an ideal gas simplify to

$$\Delta s = c_p \ln(T_2/T_1) \text{ for a constant pressure process}$$

and $\Delta s = c_v \ln(T_2/T_1)$ for a constant volume process.

Noting that $c_p > c_v$, the entropy change will be larger for a constant pressure process.

7-70 For ideal gases, $c_p = c_v + R$ and

$$\frac{P_2 V_2}{T_2} = \frac{P_1 V_1}{T_1} \longrightarrow \frac{V_2}{V_1} = \frac{T_2 P_1}{T_1 P_2}$$

Thus,

$$\begin{aligned} s_2 - s_1 &= c_v \ln\left(\frac{T_2}{T_1}\right) + R \ln\left(\frac{V_2}{V_1}\right) \\ &= c_v \ln\left(\frac{T_2}{T_1}\right) + R \ln\left(\frac{T_2 P_1}{T_1 P_2}\right) \\ &= c_v \ln\left(\frac{T_2}{T_1}\right) + R \ln\left(\frac{T_2}{T_1}\right) - R \ln\left(\frac{P_2}{P_1}\right) \\ &= c_p \ln\left(\frac{T_2}{T_1}\right) - R \ln\left(\frac{P_2}{P_1}\right) \end{aligned}$$

7-71 For an ideal gas, $dh = c_p dT$ and $v = RT/P$. From the second Tds relation,

$$ds = \frac{dh}{T} - \frac{vdP}{T} = \frac{c_p dT}{T} - \frac{RT}{P} \frac{dP}{T} = c_p \frac{dT}{T} - R \frac{dP}{P}$$

Integrating,

$$s_2 - s_1 = c_p \ln\left(\frac{T_2}{T_1}\right) - R \ln\left(\frac{P_2}{P_1}\right)$$

Since c_p is assumed to be constant.

7-72 The entropy changes of helium and nitrogen is to be compared for the same initial and final states.

Assumptions Helium and nitrogen are ideal gases with constant specific heats.

Properties The properties of helium are $c_p = 5.1926 \text{ kJ/kg}\cdot\text{K}$, $R = 2.0769 \text{ kJ/kg}\cdot\text{K}$ (Table A-2a). The specific heat of nitrogen at the average temperature of $(427+273)/2=227^\circ\text{C}=500 \text{ K}$ is $c_p = 1.056 \text{ kJ/kg}\cdot\text{K}$ (Table A-2b). The gas constant of nitrogen is $R = 0.2968 \text{ kJ/kg}\cdot\text{K}$ (Table A-2a).

Analysis From the entropy change relation of an ideal gas,

$$\begin{aligned}\Delta s_{\text{He}} &= c_p \ln \frac{T_2}{T_1} - R \ln \frac{P_2}{P_1} \\ &= (5.1926 \text{ kJ/kg}\cdot\text{K}) \ln \frac{(27+273)\text{K}}{(427+273)\text{K}} - (2.0769 \text{ kJ/kg}\cdot\text{K}) \ln \frac{200 \text{ kPa}}{2000 \text{ kPa}} \\ &= \mathbf{0.3826 \text{ kJ/kg}\cdot\text{K}}\end{aligned}$$

$$\begin{aligned}\Delta s_{\text{N}_2} &= c_p \ln \frac{T_2}{T_1} - R \ln \frac{P_2}{P_1} \\ &= (1.056 \text{ kJ/kg}\cdot\text{K}) \ln \frac{(27+273)\text{K}}{(427+273)\text{K}} - (0.2968 \text{ kJ/kg}\cdot\text{K}) \ln \frac{200 \text{ kPa}}{2000 \text{ kPa}} \\ &= \mathbf{-0.2113 \text{ kJ/kg}\cdot\text{K}}\end{aligned}$$

Hence, helium undergoes the largest change in entropy.

7-73 The entropy difference between the two states of air is to be determined.

Assumptions Air is an ideal gas with constant specific heats.

Properties The specific heat of air at the average temperature of $(500+50)/2=275^\circ\text{C} = 548 \text{ K} \cong 550 \text{ K}$ is $c_p = 1.040 \text{ kJ/kg}\cdot\text{K}$ (Table A-2b). The gas constant of air is $R = 0.287 \text{ kJ/kg}\cdot\text{K}$ (Table A-2a).

Analysis From the entropy change relation of an ideal gas,

$$\begin{aligned}\Delta s_{\text{air}} &= c_p \ln \frac{T_2}{T_1} - R \ln \frac{P_2}{P_1} \\ &= (1.040 \text{ kJ/kg}\cdot\text{K}) \ln \frac{(50+273)\text{K}}{(500+273)\text{K}} - (0.287 \text{ kJ/kg}\cdot\text{K}) \ln \frac{100 \text{ kPa}}{2000 \text{ kPa}} \\ &= \mathbf{-0.0478 \text{ kJ/kg}\cdot\text{K}}\end{aligned}$$

7-74E The entropy difference between the two states of air is to be determined.

Assumptions Air is an ideal gas with constant specific heats.

Properties The specific heat of air at the average temperature of $(90+210)/2=150^\circ\text{F}$ is $c_p = 0.241 \text{ Btu/lbm}\cdot\text{R}$ (Table A-2Eb). The gas constant of air is $R = 0.06855 \text{ Btu/lbm}\cdot\text{R}$ (Table A-2Ea).

Analysis From the entropy change relation of an ideal gas,

$$\begin{aligned}\Delta s_{\text{air}} &= c_p \ln \frac{T_2}{T_1} - R \ln \frac{P_2}{P_1} \\ &= (0.241 \text{ Btu/lbm}\cdot\text{R}) \ln \frac{(210 + 460)\text{R}}{(90 + 460)\text{R}} - (0.06855 \text{ Btu/lbm}\cdot\text{R}) \ln \frac{40 \text{ psia}}{15 \text{ psia}} \\ &= \mathbf{-0.01973 \text{ Btu/lbm}\cdot\text{R}}\end{aligned}$$

7-75 Oxygen gas is compressed from a specified initial state to a specified final state. The entropy change of oxygen during this process is to be determined for the case of constant specific heats.

Assumptions At specified conditions, oxygen can be treated as an ideal gas.

Properties The gas constant and molar mass of oxygen are $R = 0.2598 \text{ kJ/kg}\cdot\text{K}$ and $M = 32 \text{ kg/kmol}$ (Table A-1).

Analysis The constant volume specific heat of oxygen at the average temperature is (Table A-2)

$$T_{\text{avg}} = \frac{298 + 560}{2} = 429 \text{ K} \longrightarrow c_{v,\text{avg}} = 0.690 \text{ kJ/kg}\cdot\text{K}$$

Thus,

$$\begin{aligned}s_2 - s_1 &= c_{v,\text{avg}} \ln \frac{T_2}{T_1} + R \ln \frac{V_2}{V_1} \\ &= (0.690 \text{ kJ/kg}\cdot\text{K}) \ln \frac{560 \text{ K}}{298 \text{ K}} + (0.2598 \text{ kJ/kg}\cdot\text{K}) \ln \frac{0.1 \text{ m}^3/\text{kg}}{0.8 \text{ m}^3/\text{kg}} \\ &= \mathbf{-0.105 \text{ kJ/kg}\cdot\text{K}}\end{aligned}$$

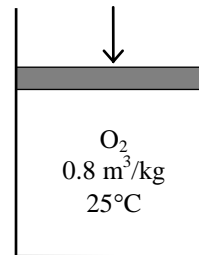

7-76 An insulated tank contains CO₂ gas at a specified pressure and volume. A paddle-wheel in the tank stirs the gas, and the pressure and temperature of CO₂ rises. The entropy change of CO₂ during this process is to be determined using constant specific heats.

Assumptions At specified conditions, CO₂ can be treated as an ideal gas with constant specific heats at room temperature.

Properties The specific heat of CO₂ is $c_v = 0.657$ kJ/kg·K (Table A-2).

Analysis Using the ideal gas relation, the entropy change is determined to be

$$\frac{P_2 V}{T_2} = \frac{P_1 V}{T_1} \longrightarrow \frac{T_2}{T_1} = \frac{P_2}{P_1} = \frac{150 \text{ kPa}}{100 \text{ kPa}} = 1.5$$

Thus,

$$\begin{aligned} \Delta S &= m(s_2 - s_1) = m \left(c_{v,\text{avg}} \ln \frac{T_2}{T_1} + R \ln \frac{V_2}{V_1} \right) = mc_{v,\text{avg}} \ln \frac{T_2}{T_1} \\ &= (2.7 \text{ kg})(0.657 \text{ kJ/kg} \cdot \text{K}) \ln(1.5) \\ &= \mathbf{0.719 \text{ kJ/K}} \end{aligned}$$

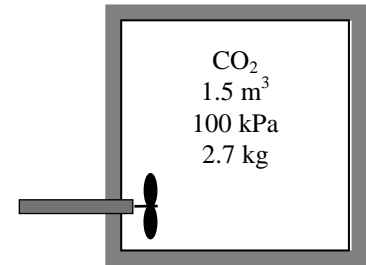

7-77 An insulated cylinder initially contains air at a specified state. A resistance heater inside the cylinder is turned on, and air is heated for 15 min at constant pressure. The entropy change of air during this process is to be determined for the cases of constant and variable specific heats.

Assumptions At specified conditions, air can be treated as an ideal gas.

Properties The gas constant of air is $R = 0.287 \text{ kJ/kg}\cdot\text{K}$ (Table A-1).

Analysis The mass of the air and the electrical work done during this process are

$$m = \frac{P_1 V_1}{RT_1} = \frac{(120 \text{ kPa})(0.3 \text{ m}^3)}{(0.287 \text{ kPa}\cdot\text{m}^3/\text{kg}\cdot\text{K})(290 \text{ K})} = 0.4325 \text{ kg}$$

$$W_{e,\text{in}} = \dot{W}_{e,\text{in}} \Delta t = (0.2 \text{ kJ/s})(15 \times 60 \text{ s}) = 180 \text{ kJ}$$

The energy balance for this stationary closed system can be expressed as

$$\underbrace{E_{\text{in}} - E_{\text{out}}}_{\text{Net energy transfer by heat, work, and mass}} = \underbrace{\Delta E_{\text{system}}}_{\text{Change in internal, kinetic, potential, etc. energies}}$$

$$W_{e,\text{in}} - W_{b,\text{out}} = \Delta U \longrightarrow W_{e,\text{in}} = m(h_2 - h_1) \cong c_p(T_2 - T_1)$$

since $\Delta U + W_b = \Delta H$ during a constant pressure quasi-equilibrium process.

(a) Using a constant c_p value at the anticipated average temperature of 450 K, the final temperature becomes

Thus,

$$T_2 = T_1 + \frac{W_{e,\text{in}}}{mc_p} = 290 \text{ K} + \frac{180 \text{ kJ}}{(0.4325 \text{ kg})(1.02 \text{ kJ/kg}\cdot\text{K})} = 698 \text{ K}$$

Then the entropy change becomes

$$\Delta S_{\text{sys}} = m(s_2 - s_1) = m \left(c_{p,\text{avg}} \ln \frac{T_2}{T_1} - R \ln \frac{P_2}{P_1} \right) = mc_{p,\text{avg}} \ln \frac{T_2}{T_1}$$

$$= (0.4325 \text{ kg})(1.020 \text{ kJ/kg}\cdot\text{K}) \ln \left(\frac{698 \text{ K}}{290 \text{ K}} \right) = \mathbf{0.387 \text{ kJ/K}}$$

(b) Assuming variable specific heats,

$$W_{e,\text{in}} = m(h_2 - h_1) \longrightarrow h_2 = h_1 + \frac{W_{e,\text{in}}}{m} = 290.16 \text{ kJ/kg} + \frac{180 \text{ kJ}}{0.4325 \text{ kg}} = 706.34 \text{ kJ/kg}$$

From the air table (Table A-17, we read $s_2^\circ = 2.5628 \text{ kJ/kg}\cdot\text{K}$ corresponding to this h_2 value. Then,

$$\Delta S_{\text{sys}} = m \left(s_2^\circ - s_1^\circ + R \ln \frac{P_2}{P_1} \right) = m(s_2^\circ - s_1^\circ) = (0.4325 \text{ kg})(2.5628 - 1.66802) \text{ kJ/kg}\cdot\text{K} = \mathbf{0.387 \text{ kJ/K}}$$

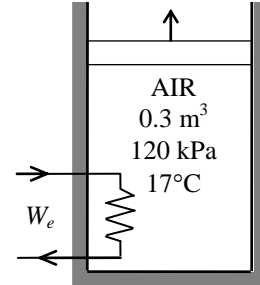

7-78 A cylinder contains N_2 gas at a specified pressure and temperature. The gas is compressed polytropically until the volume is reduced by half. The entropy change of nitrogen during this process is to be determined.

Assumptions 1 At specified conditions, N_2 can be treated as an ideal gas. **2** Nitrogen has constant specific heats at room temperature.

Properties The gas constant of nitrogen is $R = 0.2968 \text{ kJ/kg}\cdot\text{K}$ (Table A-1). The constant volume specific heat of nitrogen at room temperature is $c_v = 0.743 \text{ kJ/kg}\cdot\text{K}$ (Table A-2).

Analysis From the polytropic relation,

$$\frac{T_2}{T_1} = \left(\frac{v_1}{v_2}\right)^{n-1} \longrightarrow T_2 = T_1 \left(\frac{v_1}{v_2}\right)^{n-1} = (310 \text{ K})(2)^{1.3-1} = 381.7 \text{ K}$$

Then the entropy change of nitrogen becomes

$$\begin{aligned} \Delta S_{N_2} &= m \left(c_{v,\text{avg}} \ln \frac{T_2}{T_1} + R \ln \frac{v_2}{v_1} \right) \\ &= (0.75 \text{ kg}) \left((0.743 \text{ kJ/kg}\cdot\text{K}) \ln \frac{381.7 \text{ K}}{310 \text{ K}} + (0.2968 \text{ kJ/kg}\cdot\text{K}) \ln(0.5) \right) \\ &= \mathbf{-0.0384 \text{ kJ/K}} \end{aligned}$$

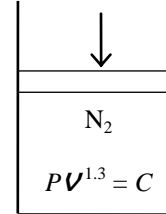



7-79 Problem 7-78 is reconsidered. The effect of varying the polytropic exponent from 1 to 1.4 on the entropy change of the nitrogen is to be investigated, and the processes are to be shown on a common P - v diagram.

Analysis The problem is solved using EES, and the results are tabulated and plotted below.

"Given"

$m=0.75$ [kg]
 $P_1=140$ [kPa]
 $T_1=(37+273)$ [K]
 $n=1.3$
 RatioV=0.5 "RatioV=V2/V1"

"Properties"

$c_v=0.743$ [kJ/kg-K]
 $R=0.297$ [kJ/kg-K]

"Analysis"

$T_2=T_1*(1/\text{RatioV})^{(n-1)}$ "from polytropic relation"
 $\Delta S=m*(c_v*\ln(T_2/T_1)+R*\ln(\text{RatioV}))$
 $P_1*V_1=m*R*T_1$

n	ΔS [kJ/kg]
1	-0.1544
1.05	-0.1351
1.1	-0.1158
1.15	-0.09646
1.2	-0.07715
1.25	-0.05783
1.3	-0.03852
1.35	-0.01921
1.4	0.000104

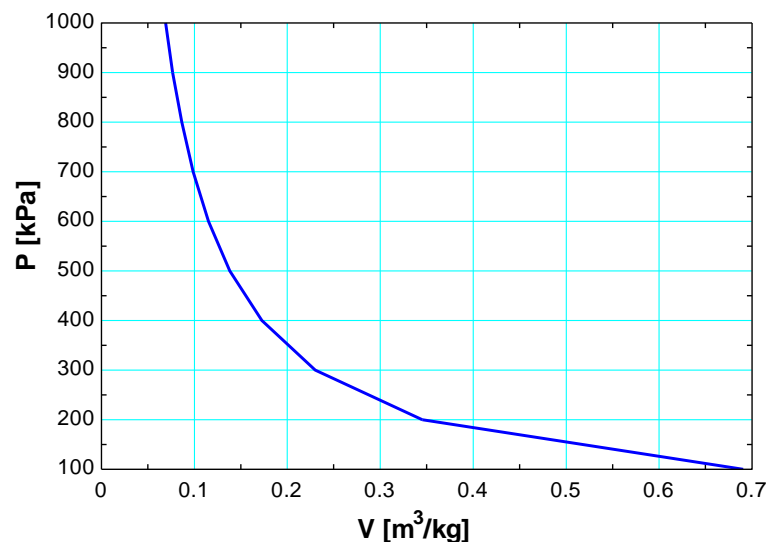
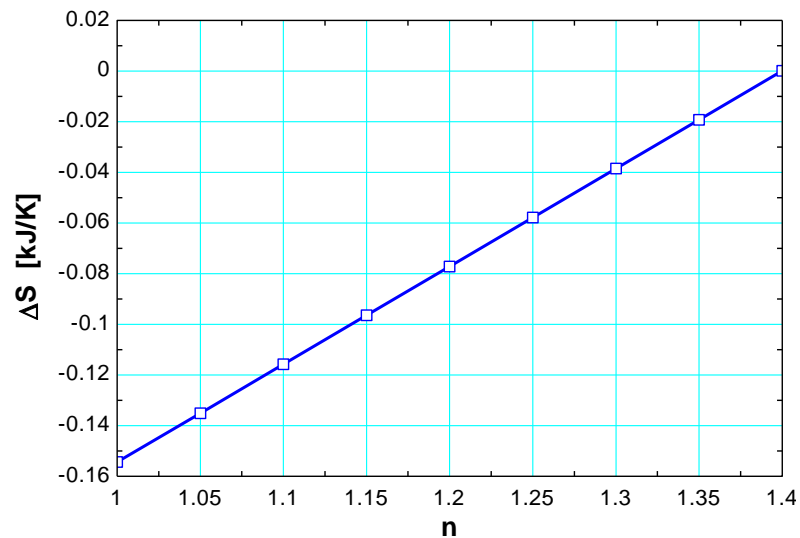

7-80 Air is compressed steadily by a 5-kW compressor from one specified state to another specified state. The rate of entropy change of air is to be determined.

Assumptions At specified conditions, air can be treated as an ideal gas. **2** Air has variable specific heats.

Properties The gas constant of air is $R = 0.287 \text{ kJ/kg}\cdot\text{K}$ (Table A-1).

Analysis From the air table (Table A-17)

$$\left. \begin{array}{l} T_1 = 290 \text{ K} \\ P_1 = 100 \text{ kPa} \end{array} \right\} s_1^\circ = 1.66802 \text{ kJ/kg}\cdot\text{K}$$

$$\left. \begin{array}{l} T_2 = 440 \text{ K} \\ P_2 = 600 \text{ kPa} \end{array} \right\} s_2^\circ = 2.0887 \text{ kJ/kg}\cdot\text{K}$$

Then the rate of entropy change of air becomes

$$\begin{aligned} \Delta \dot{S}_{\text{sys}} &= \dot{m} \left(s_2^\circ - s_1^\circ - R \ln \frac{P_2}{P_1} \right) \\ &= (1.6/60 \text{ kg/s}) \left(2.0887 - 1.66802 - (0.287 \text{ kJ/kg}\cdot\text{K}) \ln \left(\frac{600 \text{ kPa}}{100 \text{ kPa}} \right) \right) \\ &= \mathbf{-0.00250 \text{ kW/K}} \end{aligned}$$

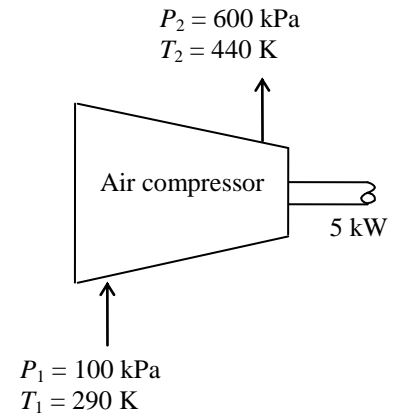

7-81 Air is accelerated in an nozzle, and some heat is lost in the process. The exit temperature of air and the total entropy change during the process are to be determined.

Assumptions 1 Air is an ideal gas with variable specific heats. 2 The nozzle operates steadily.

Analysis (a) Assuming variable specific heats, the inlet properties are determined to be,

$$T_1 = 350 \text{ K} \longrightarrow \begin{aligned} h_1 &= 350.49 \text{ kJ/kg} \\ s_1^\circ &= 1.85708 \text{ kJ/kg} \cdot \text{K} \end{aligned} \quad (\text{Table A-17})$$

We take the nozzle as the system, which is a control volume. The energy balance for this steady-flow system can be expressed in the rate form as

$$\underbrace{\dot{E}_{\text{in}} - \dot{E}_{\text{out}}}_{\text{Rate of net energy transfer by heat, work, and mass}} = \underbrace{\Delta \dot{E}_{\text{system}}^{\neq 0} (\text{steady})}_{\text{Rate of change in internal, kinetic, potential, etc. energies}} = 0$$

$$\dot{E}_{\text{in}} = \dot{E}_{\text{out}}$$

$$\dot{m}(h_1 + V_1^2/2) = \dot{m}(h_2 + V_2^2/2) + \dot{Q}_{\text{out}}$$

$$0 = q_{\text{out}} + h_2 - h_1 + \frac{V_2^2 - V_1^2}{2}$$

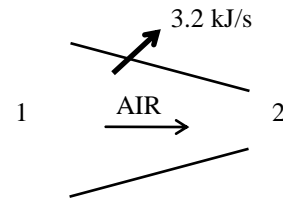

Therefore,

$$\begin{aligned} h_2 &= h_1 - q_{\text{out}} - \frac{V_2^2 - V_1^2}{2} = 350.49 - 3.2 - \frac{(320 \text{ m/s})^2 - (50 \text{ m/s})^2}{2} \left(\frac{1 \text{ kJ/kg}}{1000 \text{ m}^2/\text{s}^2} \right) \\ &= 297.34 \text{ kJ/kg} \end{aligned}$$

At this h_2 value we read, from Table A-17, $T_2 = \mathbf{297.2 \text{ K}}$, $s_2^\circ = 1.6924 \text{ kJ/kg} \cdot \text{K}$

(b) The total entropy change is the sum of the entropy changes of the air and of the surroundings, and is determined from

$$\Delta s_{\text{total}} = \Delta s_{\text{air}} + \Delta s_{\text{surr}}$$

where

$$\Delta s_{\text{air}} = s_2^\circ - s_1^\circ - R \ln \frac{P_2}{P_1} = 1.6924 - 1.85708 - (0.287 \text{ kJ/kg} \cdot \text{K}) \ln \frac{85 \text{ kPa}}{280 \text{ kPa}} = 0.1775 \text{ kJ/kg} \cdot \text{K}$$

and

$$\Delta s_{\text{surr}} = \frac{q_{\text{surr, in}}}{T_{\text{surr}}} = \frac{3.2 \text{ kJ/kg}}{293 \text{ K}} = 0.0109 \text{ kJ/kg} \cdot \text{K}$$

Thus,

$$\Delta s_{\text{total}} = 0.1775 + 0.0109 = \mathbf{0.1884 \text{ kJ/kg} \cdot \text{K}}$$



7-82 Problem 7-81 is reconsidered. The effect of varying the surrounding medium temperature from 10°C to 40°C on the exit temperature and the total entropy change for this process is to be studied, and the results are to be plotted.

Analysis The problem is solved using EES, and the results are tabulated and plotted below.

Function HCal(WorkFluid\$, Tx, Px)

"Function to calculate the enthalpy of an ideal gas or real gas"

If 'Air' = WorkFluid\$ then

HCal:=ENTHALPY('Air',T=Tx) "Ideal gas equ."

else

HCal:=ENTHALPY(WorkFluid\$,T=Tx, P=Px)"Real gas equ."

endif

end HCal

"System: control volume for the nozzle"

"Property relation: Air is an ideal gas"

"Process: Steady state, steady flow, adiabatic, no work"

"Knowns - obtain from the input diagram"

WorkFluid\$ = 'Air'

T[1] = 77 [C]

P[1] = 280 [kPa]

Vel[1] = 50 [m/s]

P[2] = 85 [kPa]

Vel[2] = 320 [m/s]

q_out = 3.2 [kJ/kg]

"T_surr = 20 [C]"

"Property Data - since the Enthalpy function has different parameters for ideal gas and real fluids, a function was used to determine h."

h[1]=HCal(WorkFluid\$,T[1],P[1])

h[2]=HCal(WorkFluid\$,T[2],P[2])

"The Volume function has the same form for an ideal gas as for a real fluid."

v[1]=volume(workFluid\$,T=T[1],p=P[1])

v[2]=volume(WorkFluid\$,T=T[2],p=P[2])

"If we knew the inlet or exit area, we could calculate the mass flow rate. Since we don't know these areas, we write the conservation of energy per unit mass."

"Conservation of mass: m_dot[1]= m_dot[2]"

"Conservation of Energy - SSSF energy balance for neglecting the change in potential energy, no work, but heat transfer out is:"

h[1]+Vel[1]^2/2*Convert(m^2/s^2, kJ/kg) = h[2]+Vel[2]^2/2*Convert(m^2/s^2, kJ/kg)+q_out

s[1]=entropy(workFluid\$,T=T[1],p=P[1])

s[2]=entropy(WorkFluid\$,T=T[2],p=P[2])

"Entropy change of the air and the surroundings are:"

DELTA_s_air = s[2] - s[1]

q_in_surr = q_out

DELTA_s_surr = q_in_surr/(T_surr+273)

DELTA_s_total = DELTA_s_air + DELTA_s_surr

ΔS_{total} [kJ/kg-K]	T_{surr} [C]	T_2 [C]
0.189	10	24.22
0.1888	15	24.22
0.1886	20	24.22
0.1884	25	24.22
0.1882	30	24.22
0.188	35	24.22
0.1879	40	24.22

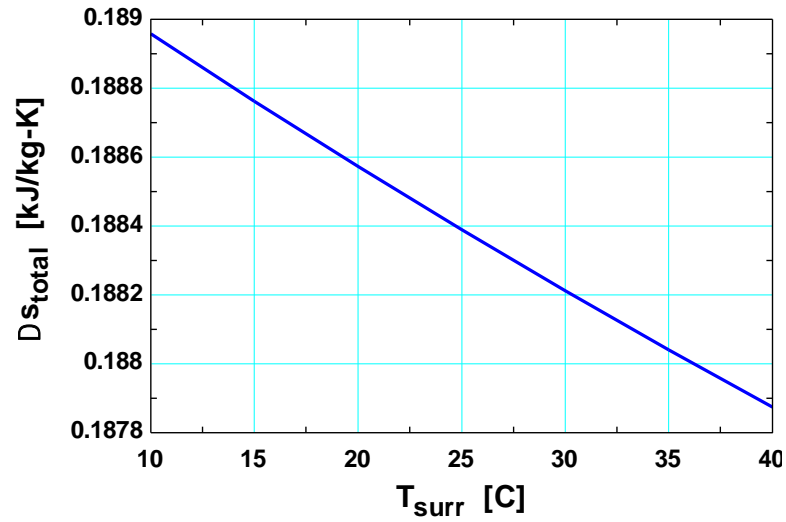

7-83E A fixed mass of helium undergoes a process from one specified state to another specified state. The entropy change of helium is to be determined for the cases of reversible and irreversible processes.

Assumptions 1 At specified conditions, helium can be treated as an ideal gas. **2** Helium has constant specific heats at room temperature.

Properties The gas constant of helium is $R = 0.4961 \text{ Btu/lbm}\cdot\text{R}$ (Table A-1E). The constant volume specific heat of helium is $c_v = 0.753 \text{ Btu/lbm}\cdot\text{R}$ (Table A-2E).

Analysis From the ideal-gas entropy change relation,

$$\begin{aligned}\Delta S_{\text{He}} &= m \left(c_{v,\text{ave}} \ln \frac{T_2}{T_1} + R \ln \frac{v_2}{v_1} \right) \\ &= (25 \text{ lbm}) \left((0.753 \text{ Btu/lbm}\cdot\text{R}) \ln \frac{700 \text{ R}}{520 \text{ R}} + (0.4961 \text{ Btu/lbm}\cdot\text{R}) \ln \left(\frac{10 \text{ ft}^3/\text{lbm}}{50 \text{ ft}^3/\text{lbm}} \right) \right) \\ &= \mathbf{-14.4 \text{ Btu/R}}\end{aligned}$$

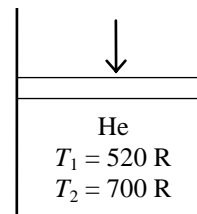

The entropy change will be the same for both cases.

7-84 Air is expanded in a piston-cylinder device isothermally until a final pressure. The amount of heat transfer is to be determined.

Assumptions Air is an ideal gas with constant specific heats.

Properties The specific heat of air at the given temperature of $127^\circ\text{C} = 400 \text{ K}$ is $c_p = 1.013 \text{ kJ/kg}\cdot\text{K}$ (Table A-2b). The gas constant of air is $R = 0.287 \text{ kJ/kg}\cdot\text{K}$ (Table A-2a).

Analysis We take the contents of the cylinder as the system. This is a closed system since no mass enters or leaves. The energy balance for this stationary closed system can be expressed as

$$\begin{aligned}\underbrace{E_{\text{in}} - E_{\text{out}}}_{\substack{\text{Net energy transfer} \\ \text{by heat, work, and mass}}} &= \underbrace{\Delta E_{\text{system}}}_{\substack{\text{Change in internal, kinetic,} \\ \text{potential, etc. energies}}} \\ Q_{\text{in}} - W_{\text{out}} &= \Delta U = m(u_2 - u_1) \quad (\text{since KE} = \text{PE} = 0) \\ Q_{\text{in}} - W_{\text{out}} &= \Delta U = m(u_2 - u_1) = 0 \quad \text{since } T_1 = T_2 \\ Q_{\text{in}} &= W_{\text{out}}\end{aligned}$$

The boundary work output during this isothermal process is

$$W_{\text{out}} = mRT \ln \frac{P_1}{P_2} = (1 \text{ kg})(0.287 \text{ kJ/kg}\cdot\text{K})(127 + 273 \text{ K}) \ln \frac{200 \text{ kPa}}{100 \text{ kPa}} = 79.6 \text{ kJ}$$

Thus,

$$Q_{\text{in}} = W_{\text{out}} = \mathbf{79.6 \text{ kJ}}$$

7-85 The final temperature of nitrogen when it is compressed isentropically is to be determined.

Assumptions Nitrogen is an ideal gas with constant specific heats.

Properties The specific heat ratio of nitrogen at an anticipated average temperature of 450 K is $k = 1.395$ (Table A-2b).

Analysis From the isentropic relation of an ideal gas under constant specific heat assumption,

$$T_2 = T_1 \left(\frac{P_2}{P_1} \right)^{(k-1)/k} = (27 + 273 \text{ K}) \left(\frac{1000 \text{ kPa}}{100 \text{ kPa}} \right)^{0.395/1.395} = \mathbf{576 \text{ K}}$$

Discussion The average air temperature is $(300+576)/2=438 \text{ K}$, which is sufficiently close to the assumed average temperature of 450 K.

7-86 Air is expanded in an adiabatic turbine. The maximum work output is to be determined.

Assumptions 1 This is a steady-flow process since there is no change with time. **2** The process is adiabatic, and thus there is no heat transfer. **3** Air is an ideal gas with constant specific heats.

Properties The properties of air at an anticipated average temperature of 550 K are $c_p = 1.040 \text{ kJ/kg}\cdot\text{K}$ and $k = 1.381$ (Table A-2b).

Analysis There is only one inlet and one exit, and thus $\dot{m}_1 = \dot{m}_2 = \dot{m}$. We take the turbine as the system, which is a control volume since mass crosses the boundary. The energy balance for this steady-flow system can be expressed in the rate form as

$$\underbrace{\dot{E}_{\text{in}} - \dot{E}_{\text{out}}}_{\text{Rate of net energy transfer by heat, work, and mass}} = \underbrace{\dot{\Delta E}_{\text{system}}}_{\text{Rate of change in internal, kinetic, potential, etc. energies}} \stackrel{\approx 0 \text{ (steady)}}{=} 0$$

$$\dot{E}_{\text{in}} = \dot{E}_{\text{out}}$$

$$\dot{m}h_1 = \dot{m}h_2 + \dot{W}_{\text{out}}$$

$$\dot{W}_{\text{out}} = \dot{m}(h_1 - h_2)$$

$$w_{\text{out}} = h_1 - h_2$$

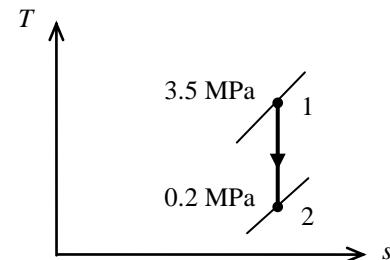
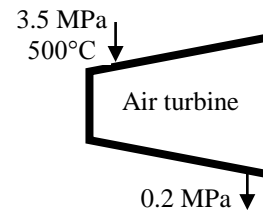

For the minimum work input to the compressor, the process must be reversible as well as adiabatic (i.e., isentropic). This being the case, the exit temperature will be

$$T_2 = T_1 \left(\frac{P_2}{P_1} \right)^{(k-1)/k} = (500 + 273 \text{ K}) \left(\frac{200 \text{ kPa}}{3500 \text{ kPa}} \right)^{0.381/1.381} = 351 \text{ K}$$

Substituting into the energy balance equation gives

$$w_{\text{out}} = h_1 - h_2 = c_p (T_1 - T_2) = (1.040 \text{ kJ/kg}\cdot\text{K})(773 - 351) \text{ K} = \mathbf{439 \text{ kJ/kg}}$$

Discussion The average air temperature is $(773+351)/2=562 \text{ K}$, which is sufficiently close to the assumed average temperature of 550 K.

7-87E Air is compressed in an isentropic compressor. The outlet temperature and the work input are to be determined.

Assumptions 1 This is a steady-flow process since there is no change with time. **2** The process is adiabatic, and thus there is no heat transfer. **3** Air is an ideal gas with constant specific heats.

Properties The properties of air at an anticipated average temperature of 400°F are $c_p = 0.245$ Btu/lbm·R and $k = 1.389$ (Table A-2Eb).

Analysis There is only one inlet and one exit, and thus $\dot{m}_1 = \dot{m}_2 = \dot{m}$. We take the compressor as the system, which is a control volume since mass crosses the boundary. The energy balance for this steady-flow system can be expressed in the rate form as

$$\underbrace{\dot{E}_{\text{in}} - \dot{E}_{\text{out}}}_{\substack{\text{Rate of net energy transfer} \\ \text{by heat, work, and mass}}} = \underbrace{\dot{\Delta E}_{\text{system}}}_{\substack{\text{Rate of change in internal, kinetic,} \\ \text{potential, etc. energies}}} \stackrel{\approx 0 \text{ (steady)}}{=} 0$$

$$\dot{E}_{\text{in}} = \dot{E}_{\text{out}}$$

$$\dot{m}h_1 + \dot{W}_{\text{in}} = \dot{m}h_2$$

$$\dot{W}_{\text{in}} = \dot{m}(h_2 - h_1)$$

The process is reversible as well as adiabatic (i.e., isentropic). This being the case, the exit temperature will be

$$T_2 = T_1 \left(\frac{P_2}{P_1} \right)^{(k-1)/k} = (70 + 460 \text{ R}) \left(\frac{200 \text{ psia}}{15 \text{ psia}} \right)^{0.389/1.389} = \mathbf{1095 \text{ R}}$$

Substituting into the energy balance equation gives

$$w_{\text{in}} = h_2 - h_1 = c_p(T_2 - T_1) = (0.245 \text{ Btu/lbm} \cdot \text{R})(1095 - 530) \text{ R} = \mathbf{138 \text{ Btu/lbm}}$$

Discussion The average air temperature is $(530 + 1095)/2 = 813 \text{ K} = 353^\circ\text{F}$, which is sufficiently close to the assumed average temperature of 400°F.

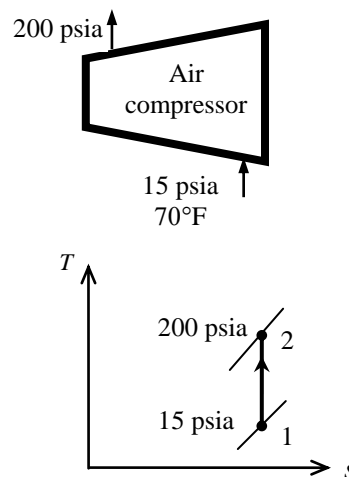

7-88 One side of a partitioned insulated rigid tank contains an ideal gas at a specified temperature and pressure while the other side is evacuated. The partition is removed, and the gas fills the entire tank. The total entropy change during this process is to be determined.

Assumptions The gas in the tank is given to be an ideal gas, and thus ideal gas relations apply.

Analysis Taking the entire rigid tank as the system, the energy balance can be expressed as

$$\underbrace{E_{\text{in}} - E_{\text{out}}}_{\substack{\text{Net energy transfer} \\ \text{by heat, work, and mass}}} = \underbrace{\Delta E_{\text{system}}}_{\substack{\text{Change in internal, kinetic,} \\ \text{potential, etc. energies}}}$$

$$0 = \Delta U = m(u_2 - u_1)$$

$$u_2 = u_1$$

$$T_2 = T_1$$

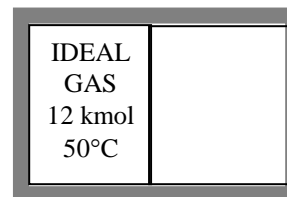

since $u = u(T)$ for an ideal gas. Then the entropy change of the gas becomes

$$\Delta S = N \left(\bar{c}_{v, \text{avg}} \ln \frac{T_2}{T_1} + R_u \ln \frac{V_2}{V_1} \right) = NR_u \ln \frac{V_2}{V_1}$$

$$= (12 \text{ kmol})(8.314 \text{ kJ/kmol} \cdot \text{K}) \ln(2)$$

$$= \mathbf{69.2 \text{ kJ/K}}$$

This also represents the **total entropy change** since the tank does not contain anything else, and there are no interactions with the surroundings.

7-89 An insulated rigid tank contains argon gas at a specified pressure and temperature. A valve is opened, and argon escapes until the pressure drops to a specified value. The final mass in the tank is to be determined.

Assumptions 1 At specified conditions, argon can be treated as an ideal gas. **2** The process is given to be reversible and adiabatic, and thus isentropic. Therefore, isentropic relations of ideal gases apply.

Properties The specific heat ratio of argon is $k = 1.667$ (Table A-2).

Analysis From the ideal gas isentropic relations,

$$T_2 = T_1 \left(\frac{P_2}{P_1} \right)^{(k-1)/k} = (303 \text{ K}) \left(\frac{200 \text{ kPa}}{450 \text{ kPa}} \right)^{0.667/1.667} = 219.0 \text{ K}$$

The final mass in the tank is determined from the ideal gas relation,

$$\frac{P_1 V}{P_2 V} = \frac{m_1 R T_1}{m_2 R T_2} \longrightarrow m_2 = \frac{P_2 T_1}{P_1 T_2} m_1 = \frac{(200 \text{ kPa})(303 \text{ K})}{(450 \text{ kPa})(219 \text{ K})} (4 \text{ kg}) = \mathbf{2.46 \text{ kg}}$$

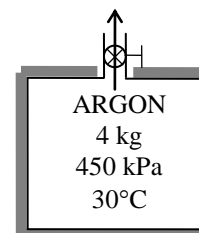



7-90 Problem 7-89 is reconsidered. The effect of the final pressure on the final mass in the tank is to be investigated as the pressure varies from 450 kPa to 150 kPa, and the results are to be plotted.

Analysis The problem is solved using EES, and the results are tabulated and plotted below.

"Knowns:"

$c_p = 0.5203$ [kJ/kg-K]
 $c_v = 0.3122$ [kJ/kg-K]
 $R = 0.2081$ [kPa-m³/kg-K]
 $P_1 = 450$ [kPa]
 $T_1 = 30$ [C]
 $m_1 = 4$ [kg]
 $P_2 = 150$ [kPa]

"Analysis:

We assume the mass that stays in the tank undergoes an isentropic expansion process. This allows us to determine the final temperature of that gas at the final pressure in the tank by using the isentropic relation:"

$k = c_p/c_v$
 $T_2 = ((T_1+273)*(P_2/P_1)^{((k-1)/k)}-273)$
 $V_2 = V_1$
 $P_1*V_1 = m_1*R*(T_1+273)$
 $P_2*V_2 = m_2*R*(T_2+273)$

P_2 [kPa]	m_2 [kg]
150	2.069
200	2.459
250	2.811
300	3.136
350	3.44
400	3.727
450	4

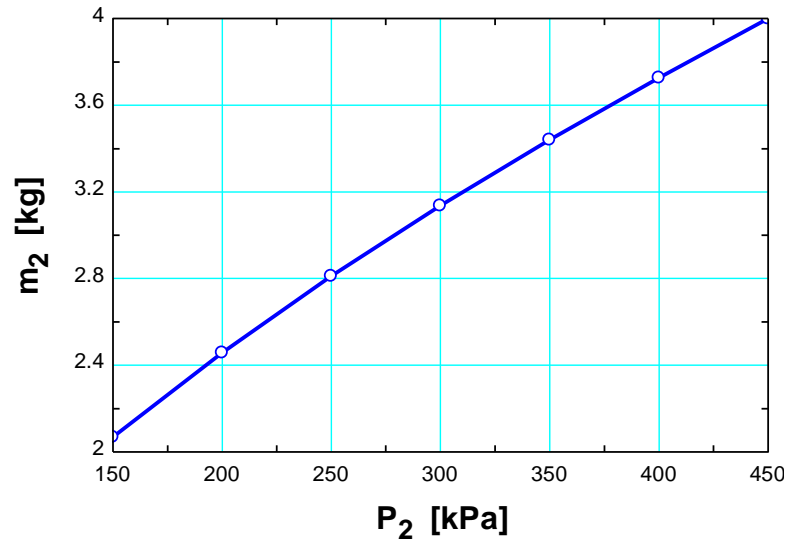

7-91E Air is accelerated in an adiabatic nozzle. Disregarding irreversibilities, the exit velocity of air is to be determined.

Assumptions 1 Air is an ideal gas with variable specific heats. **2** The process is given to be reversible and adiabatic, and thus isentropic. Therefore, isentropic relations of ideal gases apply. **2** The nozzle operates steadily.

Analysis Assuming variable specific heats, the inlet and exit properties are determined to be

$$T_1 = 1000 \text{ R} \longrightarrow \begin{matrix} P_{r_1} = 12.30 \\ h_1 = 240.98 \text{ Btu/lbm} \end{matrix}$$

and

$$P_{r_2} = \frac{P_2}{P_1} P_{r_1} = \frac{12 \text{ psia}}{60 \text{ psia}} (12.30) = 2.46 \longrightarrow \begin{matrix} T_2 = 635.9 \text{ R} \\ h_2 = 152.11 \text{ Btu/lbm} \end{matrix}$$

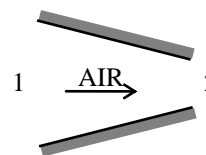

We take the nozzle as the system, which is a control volume. The energy balance for this steady-flow system can be expressed in the rate form as

$$\underbrace{\dot{E}_{\text{in}} - \dot{E}_{\text{out}}}_{\text{Rate of net energy transfer by heat, work, and mass}} = \underbrace{\Delta \dot{E}_{\text{system}}^{\neq 0} \text{ (steady)}}_{\text{Rate of change in internal, kinetic, potential, etc. energies}} = 0$$

$$\dot{E}_{\text{in}} = \dot{E}_{\text{out}}$$

$$\dot{m}(h_1 + V_1^2/2) = \dot{m}(h_2 + V_2^2/2)$$

$$h_2 - h_1 + \frac{V_2^2 - V_1^2}{2} = 0$$

Therefore,

$$\begin{aligned} V_2 &= \sqrt{2(h_1 - h_2) + V_1^2} = \sqrt{2(240.98 - 152.11) \text{ Btu/lbm} \left(\frac{25,037 \text{ ft}^2/\text{s}^2}{1 \text{ Btu/lbm}} \right) + (200 \text{ ft/s})^2} \\ &= \mathbf{2119 \text{ ft/s}} \end{aligned}$$

Alternative Solution

The enthalpy at the nozzle exit for this isentropic process can also be determined as follows: From the air table (Table A-17E)

$$T_1 = 1000 \text{ R} \longrightarrow s_1^\circ = 0.75042 \text{ Btu/lbm} \cdot \text{R}$$

For the isentropic process, the entropy change is zero. Then,

$$0 = \Delta s = s_2^\circ - s_1^\circ - R \ln(P_2 / P_1) = 0$$

or

$$s_2^\circ = s_1^\circ + R \ln(P_2 / P_1) = 0.75042 \text{ Btu/lbm} \cdot \text{R} + (0.06855 \text{ Btu/lbm} \cdot \text{R}) \ln(12/60) = 0.6401 \text{ Btu/lbm} \cdot \text{R}$$

From Table A-17E at this value, the enthalpy is obtained as

$$s_2^\circ = 0.6401 \text{ Btu/lbm} \cdot \text{R} \longrightarrow h_2 = 152.15 \text{ Btu/lbm}$$

which is practically identical to the value obtained above.

7-92 Air is expanded in a piston-cylinder device until a final pressure. The maximum work input is given. The mass of air in the device is to be determined.

Assumptions Air is an ideal gas with constant specific heats.

Properties The properties of air at 300 K is $c_v = 0.718$ kJ/kg·K and $k = 1.4$ (Table A-2a).

Analysis We take the contents of the cylinder as the system. This is a closed system since no mass enters or leaves. The energy balance for this stationary closed system can be expressed as

$$\underbrace{E_{\text{in}} - E_{\text{out}}}_{\substack{\text{Net energy transfer} \\ \text{by heat, work, and mass}}} = \underbrace{\Delta E_{\text{system}}}_{\substack{\text{Change in internal, kinetic,} \\ \text{potential, etc. energies}}} \\ -W_{\text{out}} = \Delta U = m(u_2 - u_1) \quad (\text{since } Q = \text{KE} = \text{PE} = 0)$$

For the minimum work input to the compressor, the process must be reversible as well as adiabatic (i.e., isentropic). This being the case, the exit temperature will be

$$T_2 = T_1 \left(\frac{P_2}{P_1} \right)^{(k-1)/k} = (257 + 273 \text{ K}) \left(\frac{100 \text{ kPa}}{400 \text{ kPa}} \right)^{0.4/1.4} = 356.7 \text{ K}$$

Substituting into the energy balance equation gives

$$W_{\text{out}} = m(u_1 - u_2) = mc_v(T_1 - T_2) \longrightarrow m = \frac{W_{\text{out}}}{c_v(T_1 - T_2)} = \frac{1000 \text{ kJ}}{(0.718 \text{ kJ/kg} \cdot \text{K})(530 - 356.7) \text{ K}} = \mathbf{8.04 \text{ kg}}$$

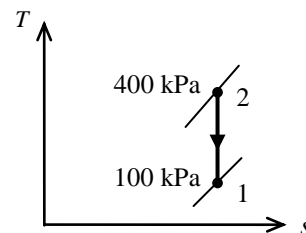

7-93 Air is compressed in a piston-cylinder device until a final pressure. The minimum work input is given. The mass of air in the device is to be determined.

Assumptions Air is an ideal gas with constant specific heats.

Properties The properties of air at 300 K is $c_v = 0.718$ kJ/kg·K and $k = 1.4$ (Table A-2a).

Analysis We take the contents of the cylinder as the system. This is a closed system since no mass enters or leaves. The energy balance for this stationary closed system can be expressed as

$$\underbrace{E_{\text{in}} - E_{\text{out}}}_{\substack{\text{Net energy transfer} \\ \text{by heat, work, and mass}}} = \underbrace{\Delta E_{\text{system}}}_{\substack{\text{Change in internal, kinetic,} \\ \text{potential, etc. energies}}} \\ W_{\text{in}} = \Delta U = m(u_2 - u_1) \quad (\text{since } Q = \text{KE} = \text{PE} = 0)$$

For the minimum work input to the compressor, the process must be reversible as well as adiabatic (i.e., isentropic). This being the case, the exit temperature will be

$$T_2 = T_1 \left(\frac{P_2}{P_1} \right)^{(k-1)/k} = (27 + 273 \text{ K}) \left(\frac{600 \text{ kPa}}{100 \text{ kPa}} \right)^{0.4/1.4} = 500.5 \text{ K}$$

Substituting into the energy balance equation gives

$$W_{\text{in}} = m(u_2 - u_1) = mc_p(T_2 - T_1) \longrightarrow m = \frac{W_{\text{in}}}{c_p(T_2 - T_1)} = \frac{1000 \text{ kJ}}{(0.718 \text{ kJ/kg} \cdot \text{K})(500.5 - 300) \text{ K}} = \mathbf{6.94 \text{ kJ/kg}}$$

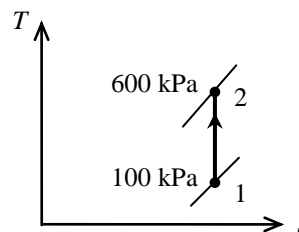

7-94 Air is compressed in a piston-cylinder device in a reversible and isothermal manner. The entropy change of air and the work done are to be determined.

Assumptions 1 At specified conditions, air can be treated as an ideal gas. **2** The process is specified to be reversible.

Properties The gas constant of air is $R = 0.287 \text{ kJ/kg}\cdot\text{K}$ (Table A-1).

Analysis (a) Noting that the temperature remains constant, the entropy change of air is determined from

$$\begin{aligned}\Delta S_{\text{air}} &= c_{p,\text{avg}} \ln \frac{T_2}{T_1} - R \ln \frac{P_2}{P_1} = -R \ln \frac{P_2}{P_1} \\ &= -(0.287 \text{ kJ/kg}\cdot\text{K}) \ln \left(\frac{400 \text{ kPa}}{90 \text{ kPa}} \right) = \mathbf{-0.428 \text{ kJ/kg}\cdot\text{K}}\end{aligned}$$

Also, for a reversible isothermal process,

$$q = T\Delta s = (293 \text{ K})(-0.428 \text{ kJ/kg}\cdot\text{K}) = -125.4 \text{ kJ/kg} \longrightarrow q_{\text{out}} = 125.4 \text{ kJ/kg}$$

(b) The work done during this process is determined from the closed system energy balance,

$$\begin{aligned}\underbrace{E_{\text{in}} - E_{\text{out}}}_{\text{Net energy transfer by heat, work, and mass}} &= \underbrace{\Delta E_{\text{system}}}_{\text{Change in internal, kinetic, potential, etc. energies}} \\ W_{\text{in}} - Q_{\text{out}} &= \Delta U = mc_v(T_2 - T_1) = 0 \\ w_{\text{in}} &= q_{\text{out}} = \mathbf{125.4 \text{ kJ/kg}}\end{aligned}$$

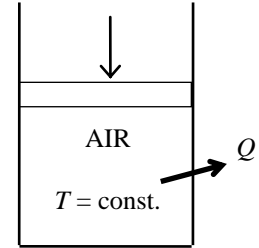

7-95 Helium gas is compressed in a piston-cylinder device in a reversible and adiabatic manner. The final temperature and the work are to be determined for the cases of the process taking place in a piston-cylinder device and a steady-flow compressor.

Assumptions 1 Helium is an ideal gas with constant specific heats. **2** The process is given to be reversible and adiabatic, and thus isentropic. Therefore, isentropic relations of ideal gases apply.

Properties The specific heats and the specific heat ratio of helium are $c_v = 3.1156 \text{ kJ/kg}\cdot\text{K}$, $c_p = 5.1926 \text{ kJ/kg}\cdot\text{K}$, and $k = 1.667$ (Table A-2).

Analysis (a) From the ideal gas isentropic relations,

$$T_2 = T_1 \left(\frac{P_2}{P_1} \right)^{(k-1)/k} = (303 \text{ K}) \left(\frac{450 \text{ kPa}}{90 \text{ kPa}} \right)^{0.667/1.667} = \mathbf{576.9 \text{ K}}$$

(a) We take the air in the cylinder as the system. The energy balance for this stationary closed system can be expressed as

$$\underbrace{E_{\text{in}} - E_{\text{out}}}_{\substack{\text{Net energy transfer} \\ \text{by heat, work, and mass}}} = \underbrace{\Delta E_{\text{system}}}_{\substack{\text{Change in internal, kinetic,} \\ \text{potential, etc. energies}}} \\ W_{\text{in}} = \Delta U = m(u_2 - u_1) \cong mc_v(T_2 - T_1)$$

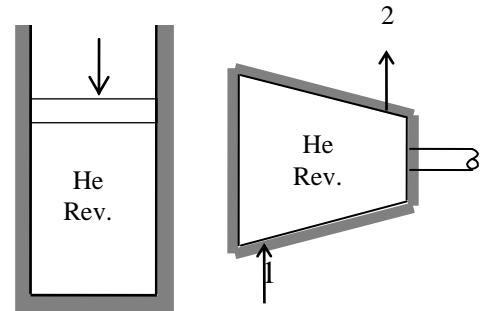

Thus,

$$w_{\text{in}} = c_v(T_2 - T_1) = (3.1156 \text{ kJ/kg}\cdot\text{K})(576.9 - 303)\text{K} = \mathbf{853.4 \text{ kJ/kg}}$$

(b) If the process takes place in a steady-flow device, the final temperature will remain the same but the work done should be determined from an energy balance on this steady-flow device,

$$\underbrace{\dot{E}_{\text{in}} - \dot{E}_{\text{out}}}_{\substack{\text{Rate of net energy transfer} \\ \text{by heat, work, and mass}}} = \underbrace{\Delta \dot{E}_{\text{system}}}_{\substack{\text{Rate of change in internal, kinetic,} \\ \text{potential, etc. energies}}} \stackrel{\text{0 (steady)}}{=} 0 \\ \dot{E}_{\text{in}} = \dot{E}_{\text{out}} \\ \dot{W}_{\text{in}} + \dot{m}h_1 = \dot{m}h_2 \\ \dot{W}_{\text{in}} = \dot{m}(h_2 - h_1) \cong \dot{m}c_p(T_2 - T_1)$$

Thus,

$$w_{\text{in}} = c_p(T_2 - T_1) = (5.1926 \text{ kJ/kg}\cdot\text{K})(576.9 - 303)\text{K} = \mathbf{1422.3 \text{ kJ/kg}}$$

7-96 Air is expanded adiabatically in a piston-cylinder device. The entropy change is to be determined and it is to be discussed if this process is realistic.

Assumptions 1 Air is an ideal gas with constant specific heats.

Properties The properties of air at 300 K are $c_p = 1.005 \text{ kJ/kg}\cdot\text{K}$, $c_v = 0.718 \text{ kJ/kg}\cdot\text{K}$ and $k = 1.4$. Also, $R = 0.287 \text{ kJ/kg}\cdot\text{K}$ (Table A-2a).

Analysis (a) We take the contents of the cylinder as the system. This is a closed system since no mass enters or leaves. The energy balance for this stationary closed system can be expressed as

$$\underbrace{E_{\text{in}} - E_{\text{out}}}_{\substack{\text{Net energy transfer} \\ \text{by heat, work, and mass}}} = \underbrace{\Delta E_{\text{system}}}_{\substack{\text{Change in internal, kinetic,} \\ \text{potential, etc. energies}}}$$

$$-W_{\text{out}} = \Delta U = m(u_2 - u_1) \quad (\text{since } Q = \text{KE} = \text{PE} = 0)$$

$$-W_{\text{out}} = mc_v(T_2 - T_1)$$

Solving for the final temperature,

$$W_{\text{out}} = mc_v(T_1 - T_2) \longrightarrow T_2 = T_1 - \frac{W_{\text{out}}}{mc_v} = (427 + 273 \text{ K}) - \frac{600 \text{ kJ}}{(5 \text{ kg})(0.718 \text{ kJ/kg}\cdot\text{K})} = 532.9 \text{ K}$$

From the entropy change relation of an ideal gas,

$$\Delta s_{\text{air}} = c_p \ln \frac{T_2}{T_1} - R \ln \frac{P_2}{P_1}$$

$$= (1.005 \text{ kJ/kg}\cdot\text{K}) \ln \frac{532.9 \text{ K}}{700 \text{ K}} - (0.287 \text{ kJ/kg}\cdot\text{K}) \ln \frac{100 \text{ kPa}}{600 \text{ kPa}}$$

$$= \mathbf{0.240 \text{ kJ/kg}\cdot\text{K}}$$

(b) Since the entropy change is positive for this adiabatic process, the process is irreversible and realistic.

7-97 A container filled with liquid water is placed in a room and heat transfer takes place between the container and the air in the room until the thermal equilibrium is established. The final temperature, the amount of heat transfer between the water and the air, and the entropy generation are to be determined.

Assumptions 1 Kinetic and potential energy changes are negligible. 2 Air is an ideal gas with constant specific heats. 3 The room is well-sealed and there is no heat transfer from the room to the surroundings. 4 Sea level atmospheric pressure is assumed. $P = 101.3 \text{ kPa}$.

Properties The properties of air at room temperature are $R = 0.287 \text{ kPa}\cdot\text{m}^3/\text{kg}\cdot\text{K}$, $c_p = 1.005 \text{ kJ/kg}\cdot\text{K}$, $c_v = 0.718 \text{ kJ/kg}\cdot\text{K}$. The specific heat of water at room temperature is $c_w = 4.18 \text{ kJ/kg}\cdot\text{K}$ (Tables A-2, A-3).

Analysis (a) The mass of the air in the room is

$$m_a = \frac{P\mathcal{V}}{RT_{a1}} = \frac{(101.3 \text{ kPa})(90 \text{ m}^3)}{(0.287 \text{ kPa}\cdot\text{m}^3/\text{kg}\cdot\text{K})(12 + 273 \text{ K})} = 111.5 \text{ kg}$$

An energy balance on the system that consists of the water in the container and the air in the room gives the final equilibrium temperature

$$0 = m_w c_w (T_2 - T_{w1}) + m_a c_v (T_2 - T_{a1})$$

$$0 = (45 \text{ kg})(4.18 \text{ kJ/kg}\cdot\text{K})(T_2 - 95) + (111.5 \text{ kg})(0.718 \text{ kJ/kg}\cdot\text{K})(T_2 - 12) \longrightarrow T_2 = \mathbf{70.2^\circ\text{C}}$$

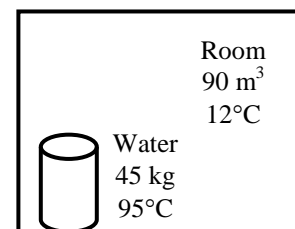

(b) The heat transfer to the air is

$$Q = m_a c_v (T_2 - T_{a1}) = (111.5 \text{ kg})(0.718 \text{ kJ/kg}\cdot\text{K})(70.2 - 12) = \mathbf{4660 \text{ kJ}}$$

(c) The entropy generation associated with this heat transfer process may be obtained by calculating total entropy change, which is the sum of the entropy changes of water and the air.

$$\Delta S_w = m_w c_w \ln \frac{T_2}{T_{w1}} = (45 \text{ kg})(4.18 \text{ kJ/kg}\cdot\text{K}) \ln \frac{(70.2 + 273) \text{ K}}{(95 + 273) \text{ K}} = -13.11 \text{ kJ/K}$$

$$P_2 = \frac{m_a R T_2}{\mathcal{V}} = \frac{(111.5 \text{ kg})(0.287 \text{ kPa}\cdot\text{m}^3/\text{kg}\cdot\text{K})(70.2 + 273 \text{ K})}{(90 \text{ m}^3)} = 122 \text{ kPa}$$

$$\begin{aligned} \Delta S_a &= m_a \left(c_p \ln \frac{T_2}{T_{a1}} - R \ln \frac{P_2}{P_1} \right) \\ &= (111.5 \text{ kg}) \left[(1.005 \text{ kJ/kg}\cdot\text{K}) \ln \frac{(70.2 + 273) \text{ K}}{(12 + 273) \text{ K}} - (0.287 \text{ kJ/kg}\cdot\text{K}) \ln \frac{122 \text{ kPa}}{101.3 \text{ kPa}} \right] = 14.88 \text{ kJ/K} \end{aligned}$$

$$S_{\text{gen}} = \Delta S_{\text{total}} = \Delta S_w + \Delta S_a = -13.11 + 14.88 = \mathbf{1.77 \text{ kJ/K}}$$

7-98E Air is charged to an initially evacuated container from a supply line. The minimum temperature of the air in the container after it is filled is to be determined.

Assumptions 1 This is an unsteady process since the conditions within the device are changing during the process, but it can be analyzed as a uniform-flow process since the state of fluid at the inlet remains constant. **2** Air is an ideal gas with constant specific heats. **3** Kinetic and potential energies are negligible. **4** The tank is well-insulated, and thus there is no heat transfer.

Properties The specific heat of air at room temperature is $c_p = 0.240$ Btu/lbm·R (Table A-2Ea).

Analysis We take the tank as the system, which is a control volume since mass crosses the boundary. Noting that the microscopic energies of flowing and nonflowing fluids are represented by enthalpy h and internal energy u , respectively, the mass and entropy balances for this uniform-flow system can be expressed as

Mass balance:

$$m_{\text{in}} - m_{\text{out}} = \Delta m_{\text{system}}$$

$$m_i = m_2 - m_1$$

$$m_i = m_2$$

Entropy balance:

$$m_2 s_2 - m_1 s_1 + m_e s_e - m_i s_i \geq 0$$

$$m_2 s_2 - m_i s_i \geq 0$$

Combining the two balances,

$$m_2 s_2 - m_2 s_i \geq 0$$

$$s_2 - s_i \geq 0$$

The minimum temperature will result when the equal sign applies. Noting that $P_2 = P_i$, we have

$$s_2 - s_i = c_p \ln \frac{T_2}{T_i} - R \ln \frac{P_2}{P_i} = 0 \longrightarrow c_p \ln \frac{T_2}{T_i} = 0$$

Then,

$$T_2 = T_i = \mathbf{140^\circ\text{F}}$$

Alternative Solution

The reversible process requires a reversible process with work extraction during the filling-up the vessel. The work will be due to an imaginary piston doing boundary work with pressure equal to line pressure:

$$W_{\text{out}} = P_i(\mathcal{V}_2 - \mathcal{V}_1) = P_2 \mathcal{V}_2 = m_2 R T_2$$

An energy balance for the reversible process (no entropy generation) can be written as

$$m_i h_i = m_2 u_2 - m_1 u_1 + W_{\text{out}}$$

$$m_2 h_i = m_2 u_2 + m_2 R T_2$$

$$h_i = u_2 + R T_2$$

$$c_p T_i = c_v T_2 + R T_2$$

$$c_p T_i = (c_v + R) T_2$$

$$c_p T_i = c_p T_2$$

$$T_i = T_2 = \mathbf{140^\circ\text{F}}$$

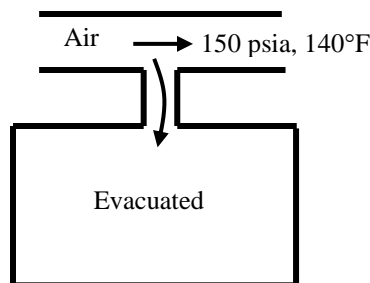

Reversible Steady-Flow Work

7-99C The work associated with steady-flow devices is proportional to the specific volume of the gas. Cooling a gas during compression will reduce its specific volume, and thus the power consumed by the compressor.

7-100C Cooling the steam as it expands in a turbine will reduce its specific volume, and thus the work output of the turbine. Therefore, this is not a good proposal.

7-101C We would not support this proposal since the steady-flow work input to the pump is proportional to the specific volume of the liquid, and cooling will not affect the specific volume of a liquid significantly.

7-102E Air is compressed isothermally in a reversible steady-flow device. The work required is to be determined.

Assumptions **1** This is a steady-flow process since there is no change with time. **2** There is no heat transfer associated with the process. **3** Kinetic and potential energy changes are negligible. **4** Air is an ideal gas with constant specific heats.

Properties The gas constant of air is $R = 0.06855 \text{ Btu/lbm}\cdot\text{R}$ (Table A-1E).

Analysis Substituting the ideal gas equation of state into the reversible steady-flow work expression gives

$$\begin{aligned} w_{\text{in}} &= \int_1^2 v dP = RT \int_1^2 \frac{dP}{P} = RT \ln \frac{P_2}{P_1} \\ &= (0.06855 \text{ Btu/lbm}\cdot\text{R})(90 + 460 \text{ K}) \ln \left(\frac{80 \text{ psia}}{13 \text{ psia}} \right) \\ &= \mathbf{68.5 \text{ Btu/lbm}} \end{aligned}$$

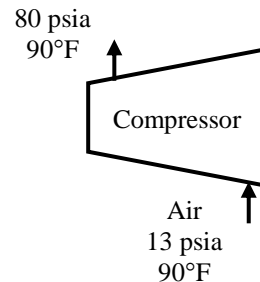

7-103 Saturated water vapor is compressed in a reversible steady-flow device. The work required is to be determined.

Assumptions **1** This is a steady-flow process since there is no change with time. **2** There is no heat transfer associated with the process. **3** Kinetic and potential energy changes are negligible.

Analysis The properties of water at the inlet state are

$$\left. \begin{array}{l} T_1 = 150^\circ\text{C} \\ x_1 = 1 \end{array} \right\} \begin{array}{l} P_1 = 476.16 \text{ kPa} \\ \nu_1 = 0.39248 \text{ m}^3/\text{kg} \end{array} \quad (\text{Table A - 4})$$

Noting that the specific volume remains constant, the reversible steady-flow work expression gives

$$\begin{aligned} w_{\text{in}} &= \int_1^2 \nu dP = \nu_1 (P_2 - P_1) \\ &= (0.39248 \text{ m}^3/\text{kg})(1000 - 476.16) \text{ kPa} \left(\frac{1 \text{ kJ}}{1 \text{ kPa} \cdot \text{m}^3} \right) \\ &= \mathbf{205.6 \text{ kJ/kg}} \end{aligned}$$

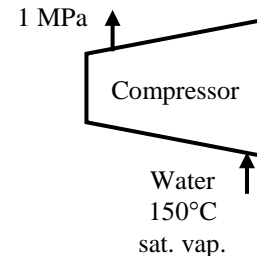

7-104E The reversible work produced during the process shown in the figure is to be determined.

Assumptions The process is reversible.

Analysis The work produced is equal to the areas to the left of the reversible process line on the P - ν diagram. The work done during the process 2-3 is zero. Then,

$$\begin{aligned} w_{13} &= w_{12} + 0 = \int_1^2 \nu dP = \frac{\nu_1 + \nu_2}{2} (P_2 - P_1) \\ &= \frac{(1 + 3) \text{ ft}^3/\text{lbm}}{2} (180 - 15) \text{ psia} \left(\frac{1 \text{ Btu}}{5.404 \text{ psia} \cdot \text{ft}^3} \right) \\ &= \mathbf{61.1 \text{ Btu/lbm}} \end{aligned}$$

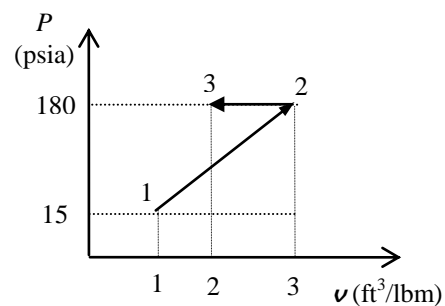

7-105 Liquid water is pumped reversibly to a specified pressure at a specified rate. The power input to the pump is to be determined.

Assumptions 1 Liquid water is an incompressible substance. 2 Kinetic and potential energy changes are negligible. 3 The process is reversible.

Properties The specific volume of saturated liquid water at 20 kPa is $\nu_1 = \nu_f @ 20 \text{ kPa} = 0.001017 \text{ m}^3/\text{kg}$ (Table A-5).

Analysis The power input to the pump can be determined directly from the steady-flow work relation for a liquid,

$$\dot{W}_{\text{in}} = \dot{m} \left(\int_1^2 \omega dP + \Delta ke^{\text{z}0} + \Delta pe^{\text{z}0} \right) = \dot{m} \nu_1 (P_2 - P_1)$$

Substituting,

$$\dot{W}_{\text{in}} = (45 \text{ kg/s})(0.001017 \text{ m}^3/\text{kg})(6000 - 20) \text{ kPa} \left(\frac{1 \text{ kJ}}{1 \text{ kPa} \cdot \text{m}^3} \right) = \mathbf{274 \text{ kW}}$$

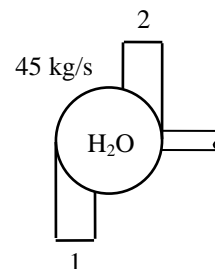

7-106 Liquid water is to be pumped by a 16-kW pump at a specified rate. The highest pressure the water can be pumped to is to be determined.

Assumptions 1 Liquid water is an incompressible substance. 2 Kinetic and potential energy changes are negligible. 3 The process is assumed to be reversible since we will determine the limiting case.

Properties The specific volume of liquid water is given to be $\nu_1 = 0.001 \text{ m}^3/\text{kg}$.

Analysis The highest pressure the liquid can have at the pump exit can be determined from the reversible steady-flow work relation for a liquid,

$$\dot{W}_{\text{in}} = \dot{m} \left(\int_1^2 \omega dP + \Delta ke^{\text{z}0} + \Delta pe^{\text{z}0} \right) = \dot{m} \nu_1 (P_2 - P_1)$$

Thus,

$$16 \text{ kJ/s} = (5 \text{ kg/s})(0.001 \text{ m}^3/\text{kg})(P_2 - 100) \text{ kPa} \left(\frac{1 \text{ kJ}}{1 \text{ kPa} \cdot \text{m}^3} \right)$$

It yields

$$P_2 = \mathbf{3300 \text{ kPa}}$$

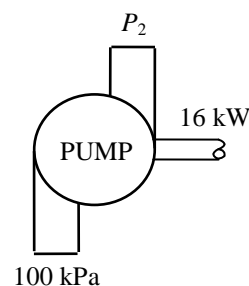

7-107 A steam power plant operates between the pressure limits of 5 MPa and 10 kPa. The ratio of the turbine work to the pump work is to be determined.

Assumptions 1 Liquid water is an incompressible substance. 2 Kinetic and potential energy changes are negligible. 3 The process is reversible. 4 The pump and the turbine are adiabatic.

Analysis Both the compression and expansion processes are reversible and adiabatic, and thus isentropic,

$s_1 = s_2$ and $s_3 = s_4$. Then the properties of the steam are

$$\left. \begin{array}{l} P_4 = 10 \text{ kPa} \\ \text{sat. vapor} \end{array} \right\} \begin{array}{l} h_4 = h_{g @ 10 \text{ kPa}} = 2583.9 \text{ kJ/kg} \\ s_4 = s_{g @ 10 \text{ kPa}} = 8.1488 \text{ kJ/kg} \cdot \text{K} \end{array}$$

$$\left. \begin{array}{l} P_3 = 5 \text{ MPa} \\ s_3 = s_4 \end{array} \right\} h_3 = 4608.1 \text{ kJ/kg}$$

Also, $v_1 = v_f @ 10 \text{ kPa} = 0.00101 \text{ m}^3/\text{kg}$.

The work output to this isentropic turbine is determined from the steady-flow energy balance to be

$$\underbrace{\dot{E}_{\text{in}} - \dot{E}_{\text{out}}}_{\text{Rate of net energy transfer by heat, work, and mass}} = \underbrace{\Delta \dot{E}_{\text{system}}}_{\text{Rate of change in internal, kinetic, potential, etc. energies}} \stackrel{\neq 0 \text{ (steady)}}{=} 0$$

$$\dot{E}_{\text{in}} = \dot{E}_{\text{out}}$$

$$\dot{m}h_3 = \dot{m}h_4 + \dot{W}_{\text{out}}$$

$$\dot{W}_{\text{out}} = \dot{m}(h_3 - h_4)$$

Substituting,

$$w_{\text{turb,out}} = h_3 - h_4 = 4608.1 - 2583.9 = 2024.2 \text{ kJ/kg}$$

The pump work input is determined from the steady-flow work relation to be

$$w_{\text{pump,in}} = \int_1^2 v dP + \Delta ke^{\neq 0} + \Delta pe^{\neq 0} = v_1(P_2 - P_1)$$

$$= (0.00101 \text{ m}^3/\text{kg})(5000 - 10) \text{ kPa} \left(\frac{1 \text{ kJ}}{1 \text{ kPa} \cdot \text{m}^3} \right)$$

$$= 5.041 \text{ kJ/kg}$$

Thus,

$$\frac{w_{\text{turb,out}}}{w_{\text{pump,in}}} = \frac{2024.2}{5.041} = \mathbf{402}$$

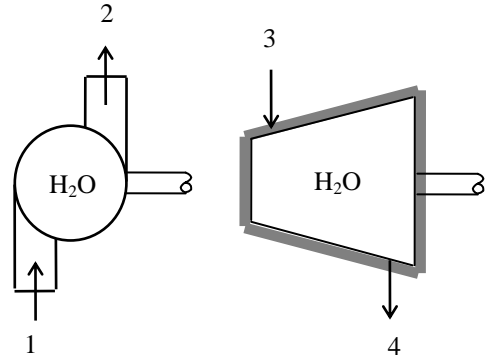



7-108 Problem 7-107 is reconsidered. The effect of the quality of the steam at the turbine exit on the net work output is to be investigated as the quality is varied from 0.5 to 1.0, and the net work output is to be plotted as a function of this quality.

Analysis The problem is solved using EES, and the results are tabulated and plotted below.

"Knowns:"

WorkFluid\$ = 'Steam_IAPWS'

P[1] = 10 [kPa]

x[1] = 0

P[2] = 5000 [kPa]

x[4] = 1.0

"Pump Analysis:"

T[1]=temperature(WorkFluid\$,P=P[1],x=0)

v[1]=volume(workFluid\$,P=P[1],x=0)

h[1]=enthalpy(WorkFluid\$,P=P[1],x=0)

s[1]=entropy(WorkFluid\$,P=P[1],x=0)

s[2] = s[1]

h[2]=enthalpy(WorkFluid\$,P=P[2],s=s[2])

T[2]=temperature(WorkFluid\$,P=P[2],s=s[2])

"The Volume function has the same form for an ideal gas as for a real fluid."

v[2]=volume(WorkFluid\$,T=T[2],p=P[2])

"Conservation of Energy - SSSF energy balance for pump"

" -- neglect the change in potential energy, no heat transfer:"

h[1]+W_pump = h[2]

"Also the work of pump can be obtained from the incompressible fluid, steady-flow result:"

W_pump_incomp = v[1]*(P[2] - P[1])

"Conservation of Energy - SSSF energy balance for turbine -- neglecting the change in potential energy, no heat transfer:"

P[4] = P[1]

P[3] = P[2]

h[4]=enthalpy(WorkFluid\$,P=P[4],x=x[4])

s[4]=entropy(WorkFluid\$,P=P[4],x=x[4])

T[4]=temperature(WorkFluid\$,P=P[4],x=x[4])

s[3] = s[4]

h[3]=enthalpy(WorkFluid\$,P=P[3],s=s[3])

T[3]=temperature(WorkFluid\$,P=P[3],s=s[3])

h[3] = h[4] + W_turb

W_net_out = W_turb - W_pump

x_4	$W_{\text{net,out}}$ [kJ/kg]
0.5	555.6
0.55	637.4
0.6	719.2
0.65	801
0.7	882.8
0.75	971.2
0.8	1087
0.85	1240
0.9	1442
0.95	1699
1	2019

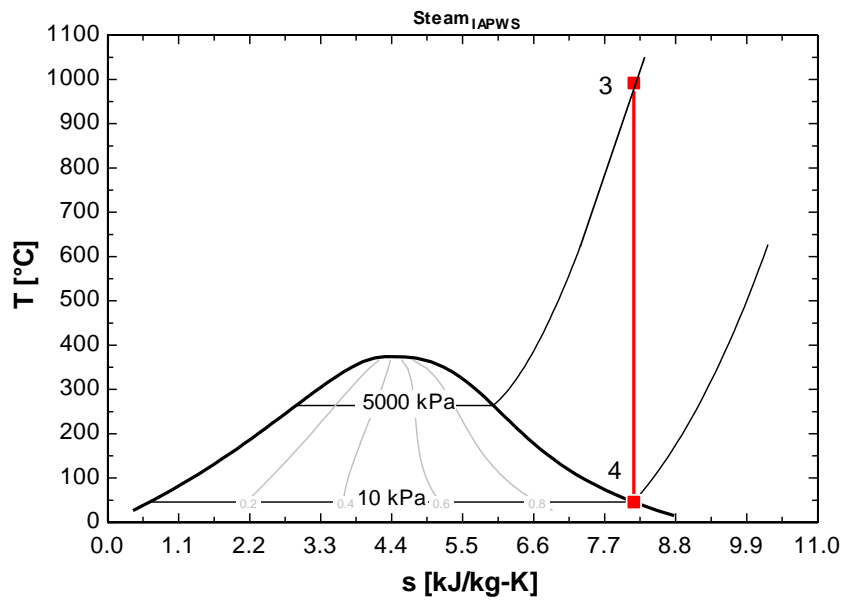
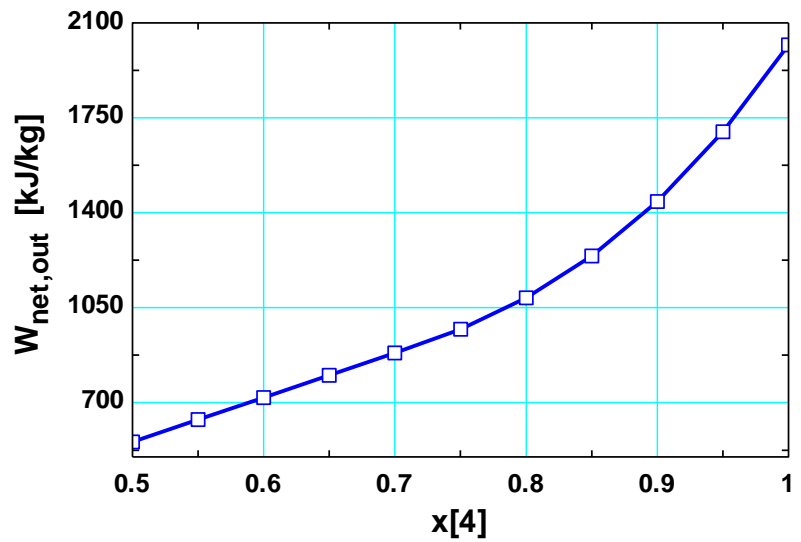

7-109E Helium gas is compressed from a specified state to a specified pressure at a specified rate. The power input to the compressor is to be determined for the cases of isentropic, polytropic, isothermal, and two-stage compression.

Assumptions 1 Helium is an ideal gas with constant specific heats. **2** The process is reversible. **3** Kinetic and potential energy changes are negligible.

Properties The gas constant of helium is $R = 2.6805 \text{ psia}\cdot\text{ft}^3/\text{lbm}\cdot\text{R} = 0.4961 \text{ Btu}/\text{lbm}\cdot\text{R}$. The specific heat ratio of helium is $k = 1.667$ (Table A-2E).

Analysis The mass flow rate of helium is

$$\dot{m} = \frac{P_1 \dot{V}_1}{RT_1} = \frac{(16 \text{ psia})(10 \text{ ft}^3/\text{s})}{(2.6805 \text{ psia}\cdot\text{ft}^3/\text{lbm}\cdot\text{R})(545 \text{ R})} = 0.1095 \text{ lbm/s}$$

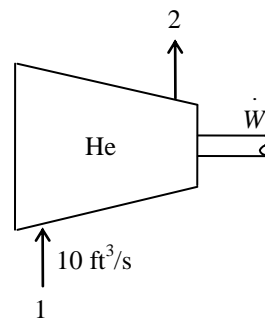

(a) Isentropic compression with $k = 1.667$:

$$\begin{aligned} \dot{W}_{\text{comp, in}} &= \dot{m} \frac{kRT_1}{k-1} \left\{ \left(\frac{P_2}{P_1} \right)^{(k-1)/k} - 1 \right\} \\ &= (0.1095 \text{ lbm/s}) \frac{(1.667)(0.4961 \text{ Btu}/\text{lbm}\cdot\text{R})(545 \text{ R})}{1.667-1} \left\{ \left(\frac{120 \text{ psia}}{16 \text{ psia}} \right)^{0.667/1.667} - 1 \right\} \\ &= 91.74 \text{ Btu/s} \\ &= \mathbf{129.8 \text{ hp}} \quad \text{since } 1 \text{ hp} = 0.7068 \text{ Btu/s} \end{aligned}$$

(b) Polytropic compression with $n = 1.2$:

$$\begin{aligned} \dot{W}_{\text{comp, in}} &= \dot{m} \frac{nRT_1}{n-1} \left\{ \left(\frac{P_2}{P_1} \right)^{(n-1)/n} - 1 \right\} \\ &= (0.1095 \text{ lbm/s}) \frac{(1.2)(0.4961 \text{ Btu}/\text{lbm}\cdot\text{R})(545 \text{ R})}{1.2-1} \left\{ \left(\frac{120 \text{ psia}}{16 \text{ psia}} \right)^{0.2/1.2} - 1 \right\} \\ &= 70.89 \text{ Btu/s} \\ &= \mathbf{100.3 \text{ hp}} \quad \text{since } 1 \text{ hp} = 0.7068 \text{ Btu/s} \end{aligned}$$

(c) Isothermal compression:

$$\dot{W}_{\text{comp, in}} = \dot{m}RT \ln \frac{P_2}{P_1} = (0.1095 \text{ lbm/s})(0.4961 \text{ Btu}/\text{lbm}\cdot\text{R})(545 \text{ R}) \ln \frac{120 \text{ psia}}{16 \text{ psia}} = 59.67 \text{ Btu/s} = \mathbf{84.42 \text{ hp}}$$

(d) Ideal two-stage compression with intercooling ($n = 1.2$): In this case, the pressure ratio across each stage is the same, and its value is determined from

$$P_x = \sqrt{P_1 P_2} = \sqrt{(16 \text{ psia})(120 \text{ psia})} = 43.82 \text{ psia}$$

The compressor work across each stage is also the same, thus total compressor work is twice the compression work for a single stage:

$$\begin{aligned} \dot{W}_{\text{comp, in}} &= 2\dot{m}w_{\text{comp, I}} = 2\dot{m} \frac{nRT_1}{n-1} \left\{ \left(\frac{P_x}{P_1} \right)^{(n-1)/n} - 1 \right\} \\ &= 2(0.1095 \text{ lbm/s}) \frac{(1.2)(0.4961 \text{ Btu}/\text{lbm}\cdot\text{R})(545 \text{ R})}{1.2-1} \left\{ \left(\frac{43.82 \text{ psia}}{16 \text{ psia}} \right)^{0.2/1.2} - 1 \right\} \\ &= 64.97 \text{ Btu/s} \\ &= \mathbf{91.92 \text{ hp}} \quad \text{since } 1 \text{ hp} = 0.7068 \text{ Btu/s} \end{aligned}$$



7-110E Problem 7-109E is reconsidered. The work of compression and entropy change of the helium is to be evaluated and plotted as functions of the polytropic exponent as it varies from 1 to 1.667.

Analysis The problem is solved using EES, and the results are tabulated and plotted below.

"Given"

P1=16 [psia]
 T1=85+460
 V1_dot=10 [ft^3/s]
 P2=120 [psia]
 n=1.2

"Properties"

R=0.4961 [Btu/lbm-R]
 R1=2.6805 [psia-ft^3/lbm-R]
 k=1.667
 c_p=1.25 [Btu/lbm-R]

"Analysis"

$m_{\dot{}}=(P1*V1_dot)/(R1*T1)$
 $W_dot_comp_in_a=m_dot*(k*R*T1)/(k-1)*((P2/P1)^{(k-1)/k}-1)*Convert(Btu/s, hp)$
 $W_dot_comp_in_b=m_dot*(n*R*T1)/(n-1)*((P2/P1)^{(n-1)/n}-1)*Convert(Btu/s, hp)$
 $W_dot_comp_in_c=m_dot*R*T1*ln(P2/P1)*Convert(Btu/s, hp)$
 $P_x=sqrt(P1*P2)$
 $W_dot_comp_in_d=2*m_dot*(n*R*T1)/(n-1)*((P_x/P1)^{(n-1)/n}-1)*Convert(Btu/s, hp)$

"Entropy change"

$T2/T1=(P2/P1)^{(n-1)/n}$
 $DELTA S_{He}=m_dot*(c_p*ln(T2/T1)-R*ln(P2/P1))$

n	$W_{comp,in,a}$ [hp]	$W_{comp,in,b}$ [hp]	$W_{comp,in,c}$ [hp]	$W_{comp,in,d}$ [hp]	ΔS_{He} [Btu/s-R]
1	129.8	84.42	84.42	84.42	-0.1095
1.1	129.8	92.64	84.42	88.41	-0.0844
1.2	129.8	100.3	84.42	91.92	-0.0635
1.3	129.8	107.5	84.42	95.04	-0.04582
1.4	129.8	114.1	84.42	97.82	-0.03066
1.5	129.8	120.3	84.42	100.3	-0.01753
1.6	129.8	126.1	84.42	102.6	-0.006036
1.667	129.8	129.8	84.42	104	0.0008937

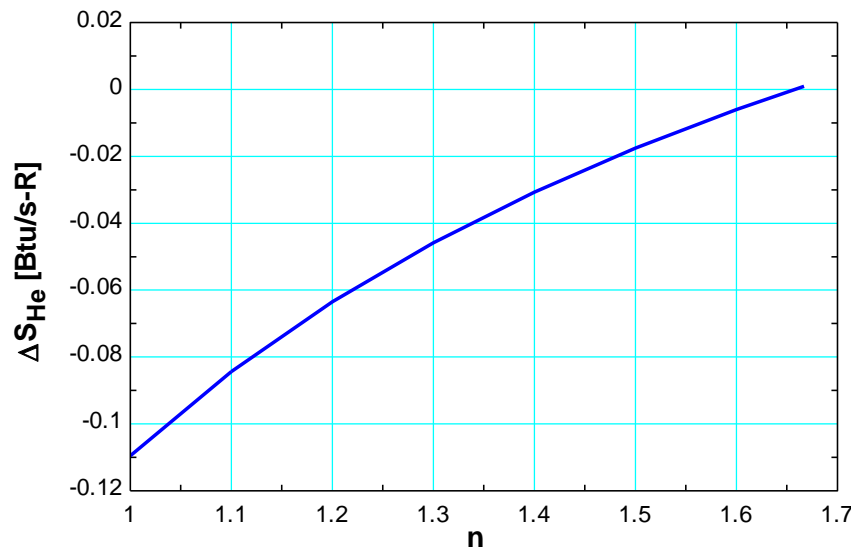
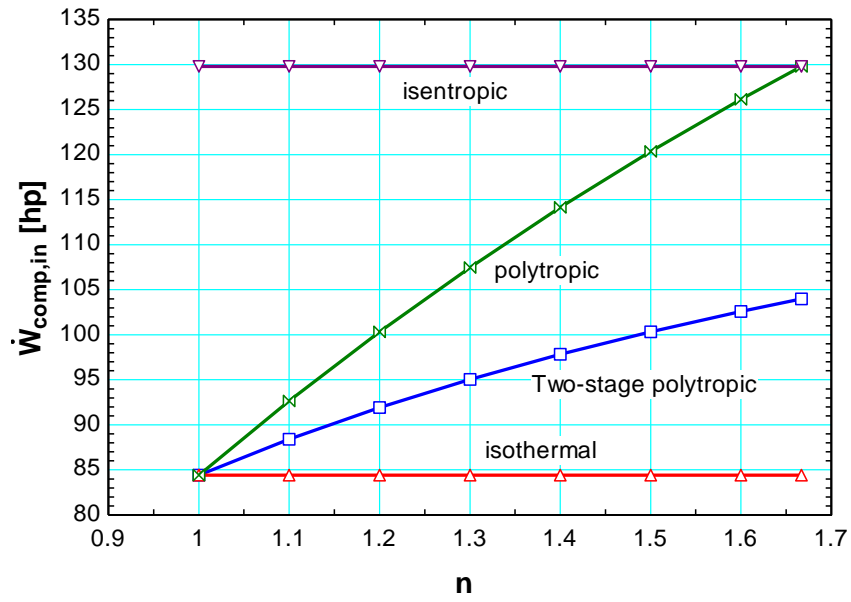

7-111 Nitrogen gas is compressed by a 10-kW compressor from a specified state to a specified pressure. The mass flow rate of nitrogen through the compressor is to be determined for the cases of isentropic, polytropic, isothermal, and two-stage compression.

Assumptions 1 Nitrogen is an ideal gas with constant specific heats. 2 The process is reversible. 3 Kinetic and potential energy changes are negligible.

Properties The gas constant of nitrogen is $R = 0.297 \text{ kJ/kg}\cdot\text{K}$ (Table A-1). The specific heat ratio of nitrogen is $k = 1.4$ (Table A-2).

Analysis (a) Isentropic compression:

$$\dot{W}_{\text{comp, in}} = \dot{m} \frac{kRT_1}{k-1} \left\{ \left(P_2/P_1 \right)^{(k-1)/k} - 1 \right\}$$

or,

$$10 \text{ kJ/s} = \dot{m} \frac{(1.4)(0.297 \text{ kJ/kg}\cdot\text{K})(300 \text{ K})}{1.4-1} \left\{ \left(480 \text{ kPa}/80 \text{ kPa} \right)^{0.4/1.4} - 1 \right\}$$

It yields

$$\dot{m} = \mathbf{0.048 \text{ kg/s}}$$

(b) Polytropic compression with $n = 1.3$:

$$\dot{W}_{\text{comp, in}} = \dot{m} \frac{nRT_1}{n-1} \left\{ \left(P_2/P_1 \right)^{(n-1)/n} - 1 \right\}$$

or,

$$10 \text{ kJ/s} = \dot{m} \frac{(1.3)(0.297 \text{ kJ/kg}\cdot\text{K})(300 \text{ K})}{1.3-1} \left\{ \left(480 \text{ kPa}/80 \text{ kPa} \right)^{0.3/1.3} - 1 \right\}$$

It yields

$$\dot{m} = \mathbf{0.051 \text{ kg/s}}$$

(c) Isothermal compression:

$$\dot{W}_{\text{comp, in}} = \dot{m}RT \ln \frac{P_1}{P_2} \longrightarrow 10 \text{ kJ/s} = \dot{m}(0.297 \text{ kJ/kg}\cdot\text{K})(300 \text{ K}) \ln \left(\frac{480 \text{ kPa}}{80 \text{ kPa}} \right)$$

It yields

$$\dot{m} = \mathbf{0.063 \text{ kg/s}}$$

(d) Ideal two-stage compression with intercooling ($n = 1.3$): In this case, the pressure ratio across each stage is the same, and its value is determined to be

$$P_x = \sqrt{P_1 P_2} = \sqrt{(80 \text{ kPa})(480 \text{ kPa})} = 196 \text{ kPa}$$

The compressor work across each stage is also the same, thus total compressor work is twice the compression work for a single stage:

$$\dot{W}_{\text{comp, in}} = 2\dot{m}w_{\text{comp, I}} = 2\dot{m} \frac{nRT_1}{n-1} \left\{ \left(P_x/P_1 \right)^{(n-1)/n} - 1 \right\}$$

or,

$$10 \text{ kJ/s} = 2\dot{m} \frac{(1.3)(0.297 \text{ kJ/kg}\cdot\text{K})(300 \text{ K})}{1.3-1} \left\{ \left(196 \text{ kPa}/80 \text{ kPa} \right)^{0.3/1.3} - 1 \right\}$$

It yields

$$\dot{m} = \mathbf{0.056 \text{ kg/s}}$$

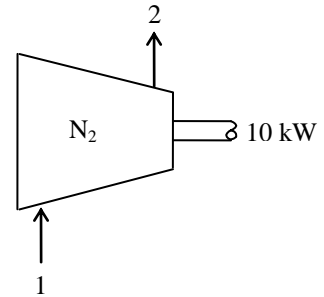

7-112E Saturated refrigerant-134a vapor is to be compressed reversibly to a specified pressure. The power input to the compressor is to be determined, and it is also to be compared to the work input for the liquid case.

Assumptions **1** Liquid refrigerant is an incompressible substance. **2** Kinetic and potential energy changes are negligible. **3** The process is reversible. **4** The compressor is adiabatic.

Analysis The compression process is reversible and adiabatic, and thus isentropic, $s_1 = s_2$. Then the properties of the refrigerant are (Tables A-11E through A-13E)

$$\left. \begin{array}{l} P_1 = 15 \text{ psia} \\ \text{sat. vapor} \end{array} \right\} \begin{array}{l} h_1 = 101.00 \text{ Btu/lbm} \\ s_1 = 0.22717 \text{ Btu/lbm} \cdot \text{R} \end{array}$$

$$\left. \begin{array}{l} P_2 = 80 \text{ psia} \\ s_2 = s_1 \end{array} \right\} h_2 = 115.81 \text{ Btu/lbm}$$

The work input to this isentropic compressor is determined from the steady-flow energy balance to be

$$\underbrace{\dot{E}_{\text{in}} - \dot{E}_{\text{out}}}_{\text{Rate of net energy transfer by heat, work, and mass}} = \underbrace{\Delta \dot{E}_{\text{system}}^{\phi 0} (\text{steady})}_{\text{Rate of change in internal, kinetic, potential, etc. energies}} = 0$$

$$\dot{E}_{\text{in}} = \dot{E}_{\text{out}}$$

$$\dot{W}_{\text{in}} + \dot{m}h_1 = \dot{m}h_2$$

$$\dot{W}_{\text{in}} = \dot{m}(h_2 - h_1)$$

Thus,

$$w_{\text{in}} = h_2 - h_1 = 115.81 - 101.00 = \mathbf{14.8 \text{ Btu/lbm}}$$

If the refrigerant were first condensed at constant pressure before it was compressed, we would use a pump to compress the liquid. In this case, the pump work input could be determined from the steady-flow work relation to be

$$w_{\text{in}} = \int_1^2 \boldsymbol{\nu} dP + \Delta ke^{\phi 0} + \Delta pe^{\phi 0} = \boldsymbol{\nu}_1 (P_2 - P_1)$$

where $\boldsymbol{\nu}_3 = \boldsymbol{\nu}_f @ 15 \text{ psia} = 0.01164 \text{ ft}^3/\text{lbm}$. Substituting,

$$w_{\text{in}} = (0.01164 \text{ ft}^3/\text{lbm})(80 - 15) \text{ psia} \left(\frac{1 \text{ Btu}}{5.4039 \text{ psia} \cdot \text{ft}^3} \right) = \mathbf{0.140 \text{ Btu/lbm}}$$

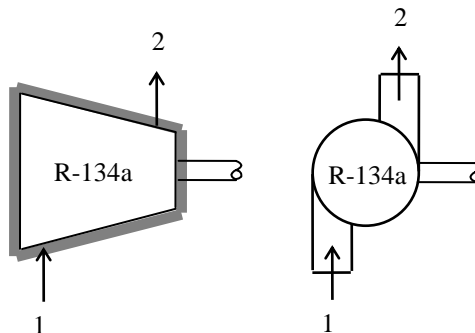

Isentropic Efficiencies of Steady-Flow Devices

7-113C The ideal process for all three devices is the reversible adiabatic (i.e., isentropic) process. The adiabatic efficiencies of these devices are defined as

$$\eta_T = \frac{\text{actual work output}}{\text{isentropic work output}}, \eta_C = \frac{\text{isentropic work input}}{\text{actual work input}}, \text{ and } \eta_N = \frac{\text{actual exit kinetic energy}}{\text{isentropic exit kinetic energy}}$$

7-114C No, because the isentropic process is not the model or ideal process for compressors that are cooled intentionally.

7-115C Yes. Because the entropy of the fluid must increase during an actual adiabatic process as a result of irreversibilities. Therefore, the actual exit state has to be on the right-hand side of the isentropic exit state

7-116E Steam is compressed in an adiabatic closed system with an isentropic efficiency of 80%. The work produced and the final temperature are to be determined.

Assumptions 1 Kinetic and potential energy changes are negligible. 2 The device is adiabatic and thus heat transfer is negligible.

Analysis We take the steam as the system. This is a closed system since no mass enters or leaves. The energy balance for this stationary closed system can be expressed as

$$\underbrace{E_{\text{in}} - E_{\text{out}}}_{\substack{\text{Net energy transfer} \\ \text{by heat, work, and mass}}} = \underbrace{\Delta E_{\text{system}}}_{\substack{\text{Change in internal, kinetic,} \\ \text{potential, etc. energies}}}$$

$$-W_{\text{out}} = \Delta U = m(u_2 - u_1)$$

$$w_{\text{out}} = u_1 - u_2$$

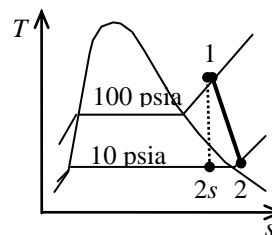

From the steam tables (Tables A-5 and A-6),

$$\left. \begin{array}{l} P_1 = 100 \text{ psia} \\ T_1 = 650^\circ\text{F} \end{array} \right\} \begin{array}{l} u_1 = 1233.7 \text{ Btu/lbm} \\ s_1 = 1.7816 \text{ Btu/lbm} \cdot \text{R} \end{array}$$

$$\left. \begin{array}{l} P_2 = 1 \text{ MPa} \\ s_{2s} = s_1 \end{array} \right\} \begin{array}{l} x_{2s} = \frac{s_{2s} - s_f}{s_{fg}} = \frac{1.7816 - 0.47427}{1.12888} = 0.9961 \\ u_{2s} = u_f + x_{2s} + u_{fg} = 298.19 + 0.9961 \times 807.29 = 1068.4 \text{ Btu/lbm} \end{array}$$

The work input during the isentropic process is

$$w_{s,\text{out}} = u_1 - u_{2s} = (1233.7 - 1068.4) \text{ Btu/lbm} = 165.3 \text{ Btu/lbm}$$

The actual work input is then

$$w_{a,\text{out}} = \eta_{\text{isen}} w_{s,\text{out}} = (0.80)(165.3 \text{ Btu/lbm}) = \mathbf{132.2 \text{ Btu/lbm}}$$

The internal energy at the final state is determined from

$$w_{\text{out}} = u_1 - u_2 \longrightarrow u_2 = u_1 - w_{\text{out}} = (1233.7 - 132.2) \text{ Btu/lbm} = 1101.4 \text{ Btu/lbm}$$

Using this internal energy and the pressure at the final state, the temperature is determined from Table A-6 to be

$$\left. \begin{array}{l} P_2 = 10 \text{ psia} \\ u_2 = 1101.4 \text{ Btu/lbm} \end{array} \right\} T_2 = \mathbf{274.6^\circ\text{F}}$$

7-117 Steam enters an adiabatic turbine at a specified state, and leaves at a specified state. The mass flow rate of the steam and the isentropic efficiency are to be determined.

Assumptions 1 This is a steady-flow process since there is no change with time. **2** Potential energy changes are negligible. **3** The device is adiabatic and thus heat transfer is negligible.

Analysis (a) From the steam tables (Tables A-4 and A-6),

$$\left. \begin{aligned} P_1 &= 5 \text{ MPa} \\ T_1 &= 650^\circ\text{C} \end{aligned} \right\} \begin{aligned} h_1 &= 3783.2 \text{ kJ/kg} \\ s_1 &= 7.3901 \text{ kJ/kg}\cdot\text{K} \end{aligned}$$

$$\left. \begin{aligned} P_2 &= 50 \text{ kPa} \\ T_2 &= 150^\circ\text{C} \end{aligned} \right\} h_{2a} = 2780.2 \text{ kJ/kg}$$

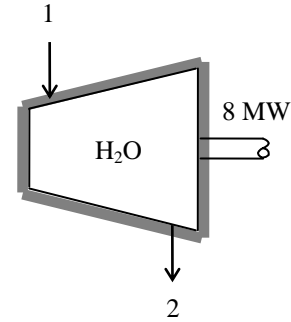

There is only one inlet and one exit, and thus $\dot{m}_1 = \dot{m}_2 = \dot{m}$. We take the actual turbine as the system, which is a control volume since mass crosses the boundary. The energy balance for this steady-flow system can be expressed in the rate form as

$$\underbrace{\dot{E}_{\text{in}} - \dot{E}_{\text{out}}}_{\text{Rate of net energy transfer by heat, work, and mass}} = \underbrace{\Delta\dot{E}_{\text{system}}^{\approx 0} \text{ (steady)}}_{\text{Rate of change in internal, kinetic, potential, etc. energies}} = 0$$

$$\dot{E}_{\text{in}} = \dot{E}_{\text{out}}$$

$$\dot{m}(h_1 + V_1^2/2) = \dot{W}_{\text{a,out}} + \dot{m}(h_2 + V_2^2/2) \quad (\text{since } \dot{Q} \cong \Delta\text{pe} \cong 0)$$

$$\dot{W}_{\text{a,out}} = -\dot{m} \left(h_2 - h_1 + \frac{V_2^2 - V_1^2}{2} \right)$$

Substituting, the mass flow rate of the steam is determined to be

$$8000 \text{ kJ/s} = -\dot{m} \left(2780.2 - 3783.2 + \frac{(140 \text{ m/s})^2 - (80 \text{ m/s})^2}{2} \left(\frac{1 \text{ kJ/kg}}{1000 \text{ m}^2/\text{s}^2} \right) \right)$$

$$\dot{m} = \mathbf{8.029 \text{ kg/s}}$$

(b) The isentropic exit enthalpy of the steam and the power output of the isentropic turbine are

$$\left. \begin{aligned} P_{2s} &= 50 \text{ kPa} \\ s_{2s} &= s_1 = 7.3901 \text{ kJ/kg}\cdot\text{K} \end{aligned} \right\} \begin{aligned} x_{2s} &= \frac{s_{2s} - s_f}{s_{fg}} = \frac{7.3901 - 1.0912}{6.5019} = 0.9688 \\ h_{2s} &= h_f + x_{2s}h_{fg} = 340.54 + (0.9688)(2304.7) = 2573.3 \text{ kJ/kg} \end{aligned}$$

and

$$\dot{W}_{\text{s,out}} = -\dot{m} \left(h_{2s} - h_1 + \frac{V_2^2 - V_1^2}{2} \right)$$

$$\dot{W}_{\text{s,out}} = -(8.029 \text{ kg/s}) \left(2573.3 - 3783.2 + \frac{(140 \text{ m/s})^2 - (80 \text{ m/s})^2}{2} \left(\frac{1 \text{ kJ/kg}}{1000 \text{ m}^2/\text{s}^2} \right) \right)$$

$$= 9661 \text{ kW}$$

Then the isentropic efficiency of the turbine becomes

$$\eta_T = \frac{\dot{W}_a}{\dot{W}_s} = \frac{8000 \text{ kW}}{9661 \text{ kW}} = 0.828 = \mathbf{82.8\%}$$

7-118E Combustion gases enter an adiabatic gas turbine with an isentropic efficiency of 82% at a specified state, and leave at a specified pressure. The work output of the turbine is to be determined.

Assumptions 1 This is a steady-flow process since there is no change with time. **2** Kinetic and potential energy changes are negligible. **3** The device is adiabatic and thus heat transfer is negligible. **4** Combustion gases can be treated as air that is an ideal gas with variable specific heats.

Analysis From the air table and isentropic relations,

$$T_1 = 2000 \text{ R} \quad \longrightarrow \quad \begin{aligned} h_1 &= 504.71 \text{ Btu/lbm} \\ P_{r_1} &= 174.0 \end{aligned}$$

$$P_{r_2} = \left(\frac{P_2}{P_1} \right) P_{r_1} = \left(\frac{60 \text{ psia}}{120 \text{ psia}} \right) (174.0) = 87.0 \longrightarrow h_{2s} = 417.3 \text{ Btu/lbm}$$

There is only one inlet and one exit, and thus $\dot{m}_1 = \dot{m}_2 = \dot{m}$. We take the actual turbine as the system, which is a control volume since mass crosses the boundary. The energy balance for this steady-flow system can be expressed as

$$\begin{aligned} \dot{E}_{\text{in}} &= \dot{E}_{\text{out}} \\ \dot{m}h_1 &= \dot{W}_{\text{a,out}} + \dot{m}h_2 \quad (\text{since } \dot{Q} \cong \Delta \text{ke} \cong \Delta \text{pe} \cong 0) \\ \dot{W}_{\text{a,out}} &= \dot{m}(h_1 - h_2) \end{aligned}$$

Noting that $w_a = \eta_T w_s$, the work output of the turbine per unit mass is determined from

$$w_a = (0.82)(504.71 - 417.3) \text{ Btu/lbm} = \mathbf{71.7 \text{ Btu/lbm}}$$

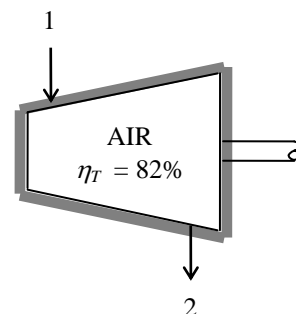

7-119 Steam is expanded in an adiabatic turbine. The isentropic efficiency is to be determined.

Assumptions 1 This is a steady-flow process since there is no change with time. **2** Kinetic and potential energy changes are negligible. **3** The device is adiabatic and thus heat transfer is negligible.

Analysis There is only one inlet and one exit, and thus $\dot{m}_1 = \dot{m}_2 = \dot{m}$. We take the actual turbine as the system, which is a control volume since mass crosses the boundary. The energy balance for this steady-flow system can be expressed in the rate form as

$$\underbrace{\dot{E}_{\text{in}} - \dot{E}_{\text{out}}}_{\text{Rate of net energy transfer by heat, work, and mass}} = \underbrace{\dot{\Delta E}_{\text{system}}}_{\text{Rate of change in internal, kinetic, potential, etc. energies}} \stackrel{\neq 0 \text{ (steady)}}{=} 0$$

$$\dot{E}_{\text{in}} = \dot{E}_{\text{out}}$$

$$\dot{m}h_1 = \dot{W}_{a,\text{out}} + \dot{m}h_2 \quad (\text{since } \dot{Q} \cong \Delta ke \cong \Delta pe \cong 0)$$

$$\dot{W}_{a,\text{out}} = \dot{m}(h_1 - h_2)$$

From the steam tables (Tables A-4 through A-6),

$$\left. \begin{array}{l} P_1 = 4 \text{ MPa} \\ T_1 = 350^\circ\text{C} \end{array} \right\} \begin{array}{l} h_1 = 3093.3 \text{ kJ/kg} \\ s_1 = 6.5843 \text{ kJ/kg} \cdot \text{K} \end{array}$$

$$\left. \begin{array}{l} P_2 = 120 \text{ kPa} \\ x_2 = 1 \end{array} \right\} \begin{array}{l} h_2 = 2683.1 \text{ kJ/kg} \end{array}$$

$$\left. \begin{array}{l} P_{2s} = 120 \text{ kPa} \\ s_{2s} = s_1 \end{array} \right\} \begin{array}{l} x_{2s} = 0.8798 \\ h_{2s} = 2413.4 \text{ kJ/kg} \end{array}$$

From the definition of the isentropic efficiency,

$$\eta_T = \frac{\dot{W}_{a,\text{out}}}{\dot{W}_{s,\text{out}}} = \frac{\dot{m}(h_1 - h_2)}{\dot{m}(h_1 - h_{2s})} = \frac{h_1 - h_2}{h_1 - h_{2s}} = \frac{3093.3 - 2683.1}{3093.3 - 2413.4} = \mathbf{0.603 = 60.3\%}$$

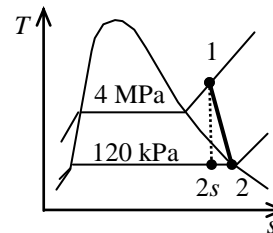
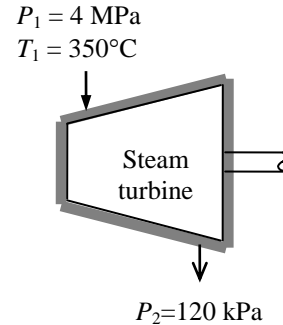

7-120 Steam enters an adiabatic turbine with an isentropic efficiency of 0.90 at a specified state with a specified mass flow rate, and leaves at a specified pressure. The turbine exit temperature and power output of the turbine are to be determined.

Assumptions 1 This is a steady-flow process since there is no change with time. 2 Kinetic and potential energy changes are negligible. 3 The device is adiabatic and thus heat transfer is negligible.

Analysis (a) From the steam tables (Tables A-4 through A-6),

$$\left. \begin{array}{l} P_1 = 8 \text{ MPa} \\ T_1 = 500^\circ\text{C} \end{array} \right\} \begin{array}{l} h_1 = 3399.5 \text{ kJ/kg} \\ s_1 = 6.7266 \text{ kJ/kg} \cdot \text{K} \end{array}$$

$$\left. \begin{array}{l} P_{2s} = 30 \text{ kPa} \\ s_{2s} = s_1 \end{array} \right\} \begin{array}{l} x_{2s} = \frac{s_{2s} - s_f}{s_{fg}} = \frac{6.7266 - 0.9441}{6.8234} = 0.8475 \\ h_{2s} = h_f + x_{2s}h_{fg} = 289.27 + (0.8475)(2335.3) = 2268.3 \text{ kJ/kg} \end{array}$$

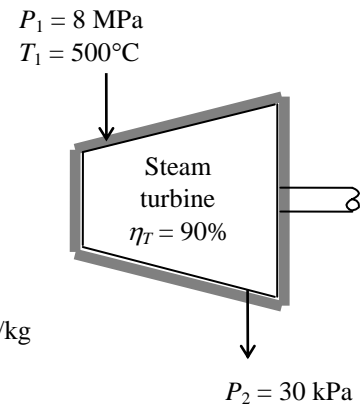

From the isentropic efficiency relation,

$$\eta_T = \frac{h_1 - h_{2a}}{h_1 - h_{2s}} \longrightarrow h_{2a} = h_1 - \eta_T (h_1 - h_{2s}) = 3399.5 - (0.9)(3399.5 - 2268.3) = 2381.4 \text{ kJ/kg}$$

Thus,

$$\left. \begin{array}{l} P_{2a} = 30 \text{ kPa} \\ h_{2a} = 2381.4 \text{ kJ/kg} \end{array} \right\} T_{2a} = T_{\text{sat}@30 \text{ kPa}} = \mathbf{69.09^\circ\text{C}}$$

(b) There is only one inlet and one exit, and thus $\dot{m}_1 = \dot{m}_2 = \dot{m}$. We take the actual turbine as the system, which is a control volume since mass crosses the boundary. The energy balance for this steady-flow system can be expressed in the rate form as

$$\underbrace{\dot{E}_{\text{in}} - \dot{E}_{\text{out}}}_{\text{Rate of net energy transfer by heat, work, and mass}} = \underbrace{\Delta \dot{E}_{\text{system}}^{\neq 0} \text{ (steady)}}_{\text{Rate of change in internal, kinetic, potential, etc. energies}} = 0$$

$$\dot{E}_{\text{in}} = \dot{E}_{\text{out}}$$

$$\dot{m}h_1 = \dot{W}_{\text{a,out}} + \dot{m}h_2 \quad (\text{since } \dot{Q} \cong \Delta \text{ke} \cong \Delta \text{pe} \cong 0)$$

$$\dot{W}_{\text{a,out}} = \dot{m}(h_1 - h_2)$$

Substituting,

$$\dot{W}_{\text{a,out}} = (3 \text{ kg/s})(3399.5 - 2381.4) \text{ kJ/kg} = \mathbf{3054 \text{ kW}}$$



7-121 Problem 7-120 is reconsidered. The effect of varying the turbine isentropic efficiency from 0.75 to 1.0 on both the work done and the exit temperature of the steam are to be investigated, and the results are to be plotted.

Analysis The problem is solved using EES, and the results are tabulated and plotted below.

"System: control volume for turbine"

"Property relation: Steam functions"

"Process: Turbine: Steady state, steady flow, adiabatic, reversible or isentropic"

"Since we don't know the mass, we write the conservation of energy per unit mass."

"Conservation of mass: $m_{\dot{1}} = m_{\dot{2}} = m_{\dot{}}$ "

"Knowns:"

WorkFluid\$ = 'Steam_iapws'

$m_{\dot{}} = 3$ [kg/s]

$P[1] = 8000$ [kPa]

$T[1] = 500$ [C]

$P[2] = 30$ [kPa]

" $\eta_{\text{turb}} = 0.9$ "

"Conservation of Energy - SSSF energy balance for turbine -- neglecting the change in potential energy, no heat transfer:"

$h[1] = \text{enthalpy}(\text{WorkFluid}\$, P=P[1], T=T[1])$

$s[1] = \text{entropy}(\text{WorkFluid}\$, P=P[1], T=T[1])$

$T_{s[1]} = T[1]$

$s[2] = s[1]$

$s_{s[2]} = s[1]$

$h_{s[2]} = \text{enthalpy}(\text{WorkFluid}\$, P=P[2], s=s_{s[2]})$

$T_{s[2]} = \text{temperature}(\text{WorkFluid}\$, P=P[2], s=s_{s[2]})$

$\eta_{\text{turb}} = w_{\text{turb}} / w_{\text{turb}_s}$

$h[1] = h[2] + w_{\text{turb}}$

$h[1] = h_{s[2]} + w_{\text{turb}_s}$

$T[2] = \text{temperature}(\text{WorkFluid}\$, P=P[2], h=h[2])$

$W_{\dot{\text{turb}}} = m_{\dot{}} \cdot w_{\text{turb}}$

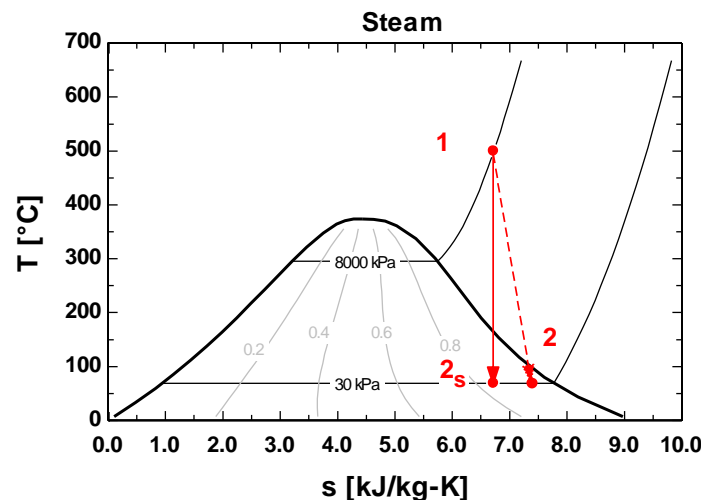

η_{turb}	W_{turb} [kW]
0.75	2545
0.8	2715
0.85	2885
0.9	3054
0.95	3224
1	3394

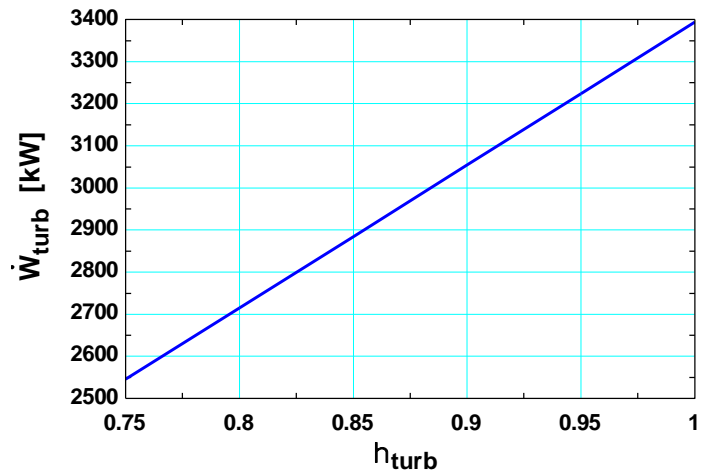

7-122 CO₂ gas is compressed by an adiabatic compressor from a specified state to another specified state. The isentropic efficiency of the compressor is to be determined.

Assumptions 1 This is a steady-flow process since there is no change with time. 2 Kinetic and potential energy changes are negligible. 3 The device is adiabatic and thus heat transfer is negligible. 4 CO₂ is an ideal gas with constant specific heats.

Properties At the average temperature of $(300 + 450)/2 = 375$ K, the constant pressure specific heat and the specific heat ratio of CO₂ are $k = 1.260$ and $c_p = 0.917$ kJ/kg·K (Table A-2).

Analysis The isentropic exit temperature T_{2s} is

$$T_{2s} = T_1 \left(\frac{P_{2s}}{P_1} \right)^{(k-1)/k} = (300 \text{ K}) \left(\frac{600 \text{ kPa}}{100 \text{ kPa}} \right)^{0.260/1.260} = 434.2 \text{ K}$$

From the isentropic efficiency relation,

$$\eta_c = \frac{w_s}{w_a} = \frac{h_{2s} - h_1}{h_{2a} - h_1} = \frac{c_p(T_{2s} - T_1)}{c_p(T_{2a} - T_1)} = \frac{T_{2s} - T_1}{T_{2a} - T_1} = \frac{434.2 - 300}{450 - 300} = 0.895 = \mathbf{89.5\%}$$

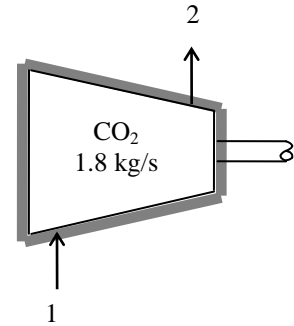

7-123 R-134a is compressed by an adiabatic compressor with an isentropic efficiency of 85%. The power required is to be determined.

Assumptions 1 This is a steady-flow process since there is no change with time. 2 Kinetic and potential energy changes are negligible. 3 The device is adiabatic and thus heat transfer is negligible.

Analysis From the R-134a tables (Tables A-11 through A-13),

$$\left. \begin{array}{l} T_1 = 10^\circ\text{C} \\ x = 1 \text{ (sat. vap.)} \end{array} \right\} \begin{array}{l} h_1 = 256.22 \text{ kJ/kg} \\ s_1 = 0.9266 \text{ kJ/kg} \cdot \text{K} \end{array}$$

$$\left. \begin{array}{l} P_2 = 1000 \text{ kPa} \\ s_{2s} = s_1 = 0.9266 \text{ kJ/kg} \cdot \text{K} \end{array} \right\} h_{2s} = 274.45 \text{ kJ/kg}$$

The power input during isentropic process would be

$$\dot{W}_{s,\text{in}} = \dot{m}(h_{2s} - h_1) = (0.9 \text{ kg/s})(274.45 - 256.22) \text{ kJ/kg} = 16.41 \text{ kW}$$

The power input during the actual process is

$$\dot{W}_{\text{in}} = \frac{\dot{W}_{s,\text{in}}}{\eta_c} = \frac{16.41 \text{ kW}}{0.85} = \mathbf{19.3 \text{ kW}}$$

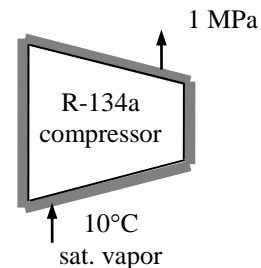

7-124  Refrigerant-134a enters an adiabatic compressor with an isentropic efficiency of 0.87 at a specified state with a specified volume flow rate, and leaves at a specified pressure. The compressor exit temperature and power input to the compressor are to be determined.

Assumptions **1** This is a steady-flow process since there is no change with time. **2** Kinetic and potential energy changes are negligible. **3** The device is adiabatic and thus heat transfer is negligible.

Analysis (a) From the refrigerant tables (Tables A-11E through A-13E),

$$P_1 = 100 \text{ kPa} \left. \begin{array}{l} h_1 = h_{g@100\text{kPa}} = 234.46 \text{ kJ/kg} \\ s_1 = s_{g@100\text{kPa}} = 0.95191 \text{ kJ/kg} \cdot \text{K} \\ v_1 = v_{g@100\text{kPa}} = 0.19255 \text{ m}^3/\text{kg} \end{array} \right\} \text{sat. vapor}$$

$$P_2 = 1 \text{ MPa} \left. \begin{array}{l} h_{2s} = 282.53 \text{ kJ/kg} \\ s_{2s} = s_1 \end{array} \right\}$$

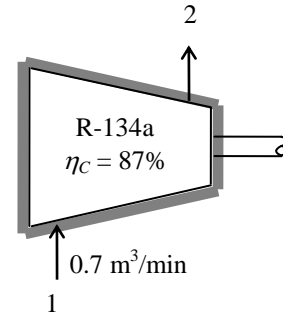

From the isentropic efficiency relation,

$$\eta_c = \frac{h_{2s} - h_1}{h_{2a} - h_1} \longrightarrow h_{2a} = h_1 + (h_{2s} - h_1)/\eta_c = 234.46 + (282.53 - 234.46)/0.87 = 289.71 \text{ kJ/kg}$$

Thus,

$$\left. \begin{array}{l} P_{2a} = 1 \text{ MPa} \\ h_{2a} = 289.71 \text{ kJ/kg} \end{array} \right\} T_{2a} = \mathbf{56.5^\circ\text{C}}$$

(b) The mass flow rate of the refrigerant is determined from

$$\dot{m} = \frac{\dot{V}_1}{v_1} = \frac{0.7/60 \text{ m}^3/\text{s}}{0.19255 \text{ m}^3/\text{kg}} = 0.06059 \text{ kg/s}$$

There is only one inlet and one exit, and thus $\dot{m}_1 = \dot{m}_2 = \dot{m}$. We take the actual compressor as the system, which is a control volume since mass crosses the boundary. The energy balance for this steady-flow system can be expressed as

$$\underbrace{\dot{E}_{\text{in}} - \dot{E}_{\text{out}}}_{\text{Rate of net energy transfer by heat, work, and mass}} = \underbrace{\Delta \dot{E}_{\text{system}}^{\neq 0} \text{ (steady)}}_{\text{Rate of change in internal, kinetic, potential, etc. energies}} = 0$$

$$\dot{E}_{\text{in}} = \dot{E}_{\text{out}}$$

$$\dot{W}_{\text{a,in}} + \dot{m}h_1 = \dot{m}h_2 \quad (\text{since } \dot{Q} \cong \Delta \text{ke} \cong \Delta \text{pe} \cong 0)$$

$$\dot{W}_{\text{a,in}} = \dot{m}(h_2 - h_1)$$

Substituting, the power input to the compressor becomes,

$$\dot{W}_{\text{a,in}} = (0.06059 \text{ kg/s})(289.71 - 234.46) \text{ kJ/kg} = \mathbf{3.35 \text{ kW}}$$



7-125 Problem 7-124 is reconsidered. The problem is to be solved by considering the kinetic energy and by assuming an inlet-to-exit area ratio of 1.5 for the compressor when the compressor exit pipe inside diameter is 2 cm.

Analysis The problem is solved using EES, and the solution is given below.

"Input Data from diagram window"

```
{P[1] = 100 [kPa]
P[2] = 1000 [kPa]
Vol_dot_1 = 0.7 [m^3/min]
Eta_c = 0.87 "Compressor adiabatic efficiency"
A_ratio = 1.5
d_2 = 0.02 [m]}
```

"System: Control volume containing the compressor, see the diagram window.

Property Relation: Use the real fluid properties for R134a.

Process: Steady-state, steady-flow, adiabatic process."

Fluid\$='R134a'

"Property Data for state 1"

```
T[1]=temperature(Fluid$,P=P[1],x=1)"Real fluid equ. at the sat. vapor state"
h[1]=enthalpy(Fluid$, P=P[1], x=1)"Real fluid equ. at the sat. vapor state"
s[1]=entropy(Fluid$, P=P[1], x=1)"Real fluid equ. at the sat. vapor state"
v[1]=volume(Fluid$, P=P[1], x=1)"Real fluid equ. at the sat. vapor state"
```

"Property Data for state 2"

```
s_s[1]=s[1]; T_s[1]=T[1] "needed for plot"
s_s[2]=s[1] "for the ideal, isentropic process across the compressor"
h_s[2]=ENTHALPY(Fluid$, P=P[2], s=s_s[2])"Enthalpy 2 at the isentropic state 2s and pressure P[2]"
T_s[2]=Temperature(Fluid$, P=P[2], s=s_s[2])"Temperature of ideal state - needed only for plot."
```

"Steady-state, steady-flow conservation of mass"

```
m_dot_1 = m_dot_2
m_dot_1 = Vol_dot_1/(v[1]*60)
Vol_dot_1/v[1]=Vol_dot_2/v[2]
Vel[2]=Vol_dot_2/(A[2]*60)
A[2] = pi*(d_2)^2/4
A_ratio*Vel[1]/v[1] = Vel[2]/v[2] "Mass flow rate: = A*Vel/v, A_ratio = A[1]/A[2]"
A_ratio=A[1]/A[2]
```

"Steady-state, steady-flow conservation of energy, adiabatic compressor, see diagram window"

```
m_dot_1*(h[1]+(Vel[1])^2/(2*1000)) + W_dot_c= m_dot_2*(h[2]+(Vel[2])^2/(2*1000))
```

"Definition of the compressor isentropic efficiency, $\text{Eta}_c = W_{\text{isen}}/W_{\text{act}}$ "

```
Eta_c = (h_s[2]-h[1])/(h[2]-h[1])
```

"Knowing $h[2]$, the other properties at state 2 can be found."

```
v[2]=volume(Fluid$, P=P[2], h=h[2])"v[2] is found at the actual state 2, knowing P and h."
T[2]=temperature(Fluid$, P=P[2], h=h[2])"Real fluid equ. for T at the known outlet h and P."
s[2]=entropy(Fluid$, P=P[2], h=h[2]) "Real fluid equ. at the known outlet h and P."
T_exit=T[2]
```

"Neglecting the kinetic energies, the work is:"

```
m_dot_1*h[1] + W_dot_c_noke= m_dot_2*h[2]
```

SOLUTION

A_ratio=1.5

d_2=0.02 [m]

Eta_c=0.87

Fluid\$='R134a'

m_dot_1=0.06059 [kg/s]

m_dot_2=0.06059 [kg/s]

T_exit=56.51 [C]

Vol_dot_1=0.7 [m^3 /min]

Vol_dot_2=0.08229 [m^3 /min]

W_dot_c=3.33 [kW]

W_dot_c_noke=3.348 [kW]

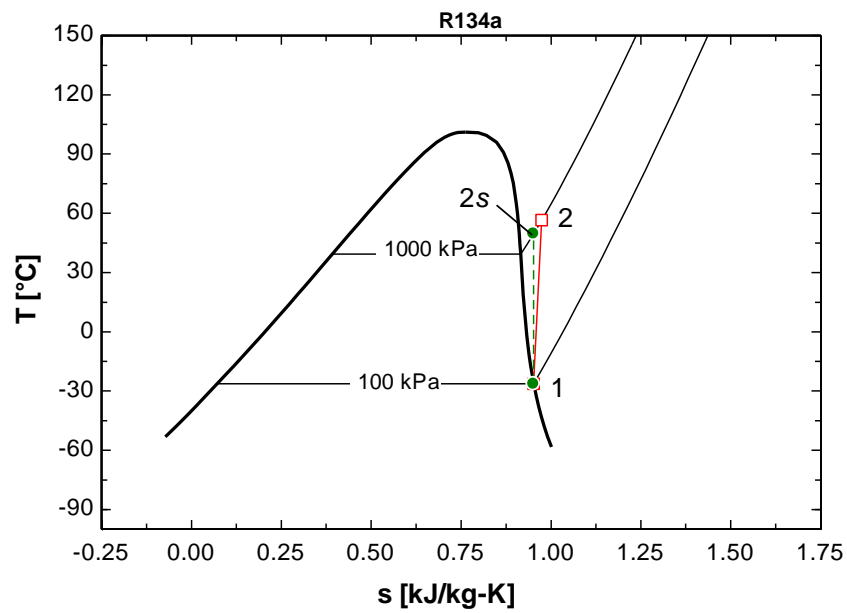

7-126 Air is compressed by an adiabatic compressor from a specified state to another specified state. The isentropic efficiency of the compressor and the exit temperature of air for the isentropic case are to be determined.

Assumptions 1 This is a steady-flow process since there is no change with time. **2** Kinetic and potential energy changes are negligible. **3** The device is adiabatic and thus heat transfer is negligible. **4** Air is an ideal gas with variable specific heats.

Analysis (a) From the air table (Table A-17),

$$T_1 = 300 \text{ K} \longrightarrow h_1 = 300.19 \text{ kJ/kg}, \quad P_{r_1} = 1.386$$

$$T_2 = 550 \text{ K} \longrightarrow h_{2a} = 554.74 \text{ kJ/kg}$$

From the isentropic relation,

$$P_{r_2} = \left(\frac{P_2}{P_1} \right) P_{r_1} = \left(\frac{600 \text{ kPa}}{95 \text{ kPa}} \right) (1.386) = 8.754 \longrightarrow h_{2s} = 508.72 \text{ kJ/kg}$$

Then the isentropic efficiency becomes

$$\eta_c = \frac{h_{2s} - h_1}{h_{2a} - h_1} = \frac{508.72 - 300.19}{554.74 - 300.19} = 0.819 = \mathbf{81.9\%}$$

(b) If the process were isentropic, the exit temperature would be

$$h_{2s} = 508.72 \text{ kJ/kg} \longrightarrow T_{2s} = 505.5 \text{ K} \cong \mathbf{506 \text{ K}}$$

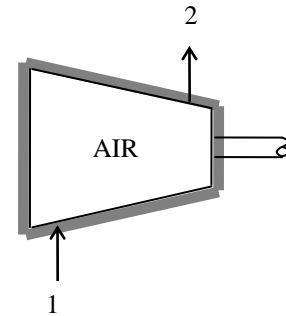

7-127E Argon enters an adiabatic compressor with an isentropic efficiency of 80% at a specified state, and leaves at a specified pressure. The exit temperature of argon and the work input to the compressor are to be determined.

Assumptions 1 This is a steady-flow process since there is no change with time. **2** Potential energy changes are negligible. **3** The device is adiabatic and thus heat transfer is negligible. **4** Argon is an ideal gas with constant specific heats.

Properties The specific heat ratio of argon is $k = 1.667$. The constant pressure specific heat of argon is $c_p = 0.1253 \text{ Btu/lbm}\cdot\text{R}$ (Table A-2E).

Analysis (a) The isentropic exit temperature T_{2s} is determined from

$$T_{2s} = T_1 \left(\frac{P_{2s}}{P_1} \right)^{(k-1)/k} = (535 \text{ R}) \left(\frac{200 \text{ psia}}{14 \text{ psia}} \right)^{0.667/1.667} = 1550.4 \text{ R}$$

The actual kinetic energy change during this process is

$$\Delta ke_a = \frac{V_2^2 - V_1^2}{2} = \frac{(240 \text{ ft/s})^2 - (60 \text{ ft/s})^2}{2} \left(\frac{1 \text{ Btu/lbm}}{25,037 \text{ ft}^2/\text{s}^2} \right) = 1.078 \text{ Btu/lbm}$$

The effect of kinetic energy on isentropic efficiency is very small. Therefore, we can take the kinetic energy changes for the actual and isentropic cases to be same in efficiency calculations. From the isentropic efficiency relation, including the effect of kinetic energy,

$$\eta_c = \frac{w_s}{w_a} = \frac{(h_{2s} - h_1) + \Delta ke}{(h_{2a} - h_1) + \Delta ke} = \frac{c_p(T_{2s} - T_1) + \Delta ke_s}{c_p(T_{2a} - T_1) + \Delta ke_a} \longrightarrow 0.87 = \frac{0.1253(1550.4 - 535) + 1.078}{0.1253(T_{2a} - 535) + 1.078}$$

It yields

$$T_{2a} = \mathbf{1703 \text{ R}}$$

(b) There is only one inlet and one exit, and thus $\dot{m}_1 = \dot{m}_2 = \dot{m}$. We take the actual compressor as the system, which is a control volume since mass crosses the boundary. The energy balance for this steady-flow system can be expressed as

$$\underbrace{\dot{E}_{\text{in}} - \dot{E}_{\text{out}}}_{\text{Rate of net energy transfer by heat, work, and mass}} = \underbrace{\Delta \dot{E}_{\text{system}}}_{\text{Rate of change in internal, kinetic, potential, etc. energies}} \stackrel{\cong 0 \text{ (steady)}}{=} 0$$

$$\dot{E}_{\text{in}} = \dot{E}_{\text{out}}$$

$$\dot{W}_{\text{a,in}} + \dot{m}(h_1 + V_1^2/2) = \dot{m}(h_2 + V_2^2/2) \quad (\text{since } \dot{Q} \cong \Delta pe \cong 0)$$

$$\dot{W}_{\text{a,in}} = \dot{m} \left(h_2 - h_1 + \frac{V_2^2 - V_1^2}{2} \right) \longrightarrow w_{\text{a,in}} = h_2 - h_1 + \Delta ke_a = c_p(T_{2a} - T_1) + \Delta ke_a$$

Substituting, the work input to the compressor is determined to be

$$w_{\text{a,in}} = (0.1253 \text{ Btu/lbm}\cdot\text{R})(1703 - 535)\text{R} + 1.078 \text{ Btu/lbm} = \mathbf{147 \text{ Btu/lbm}}$$

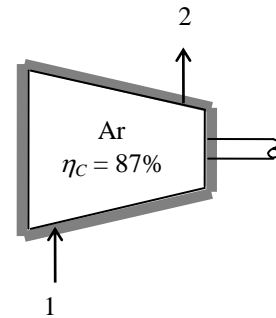

7-128E Air is accelerated in a 85% efficient adiabatic nozzle from low velocity to a specified velocity. The exit temperature and pressure of the air are to be determined.

Assumptions 1 This is a steady-flow process since there is no change with time. **2** Potential energy changes are negligible. **3** The device is adiabatic and thus heat transfer is negligible. **4** Air is an ideal gas with variable specific heats.

Analysis From the air table (Table A-17E),

$$T_1 = 1400 \text{ R} \longrightarrow h_1 = 342.90 \text{ Btu/lbm}, P_{r_1} = 42.88$$

There is only one inlet and one exit, and thus $\dot{m}_1 = \dot{m}_2 = \dot{m}$. We take the nozzle as the system, which is a control volume since mass crosses the boundary. The energy balance for this steady-flow system can be expressed as

$$\underbrace{\dot{E}_{\text{in}} - \dot{E}_{\text{out}}}_{\text{Rate of net energy transfer by heat, work, and mass}} = \underbrace{\Delta \dot{E}_{\text{system}}^{\phi_0} \text{ (steady)}}_{\text{Rate of change in internal, kinetic, potential, etc. energies}} = 0$$

$$\dot{E}_{\text{in}} = \dot{E}_{\text{out}}$$

$$\dot{m}(h_1 + V_1^2/2) = \dot{m}(h_2 + V_2^2/2) \quad (\text{since } \dot{W} = \dot{Q} \cong \Delta p_e \cong 0)$$

$$h_2 = h_1 - \frac{V_2^2 - V_1^2}{2}$$

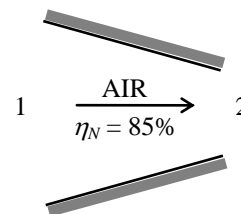

Substituting, the exit temperature of air is determined to be

$$h_2 = 342.90 \text{ kJ/kg} - \frac{(650 \text{ ft/s})^2 - 0}{2} \left(\frac{1 \text{ Btu/lbm}}{25,037 \text{ ft}^2/\text{s}^2} \right) = 334.46 \text{ Btu/lbm}$$

From the air table we read

$$T_{2a} = \mathbf{1368 \text{ R} = 908^\circ\text{F}}$$

From the isentropic efficiency relation

$$\eta_N = \frac{h_{2a} - h_1}{h_{2s} - h_1}$$

or

$$h_{2s} = h_1 + (h_{2a} - h_1)/\eta_N = 342.90 + (334.46 - 342.90)/(0.85) = 332.97 \text{ Btu/lbm} \longrightarrow P_{r_2} = 38.62$$

Then the exit pressure is determined from the isentropic relation to be

$$\frac{P_2}{P_1} = \frac{P_{r_2}}{P_{r_1}} \longrightarrow P_2 = \left(\frac{P_{r_2}}{P_{r_1}} \right) P_1 = \left(\frac{38.62}{42.88} \right) (45 \text{ psia}) = \mathbf{40.5 \text{ psia}}$$



7-129E Problem 7-128E is reconsidered. The effect of varying the nozzle isentropic efficiency from 0.8 to 1.0 on the exit temperature and pressure of the air is to be investigated, and the results are to be plotted.

Analysis The problem is solved using EES, and the results are tabulated and plotted below.

"Knowns:"

WorkFluid\$ = 'Air'
 P[1] = 45 [psia]
 T[1] = 940 [F]
 Vel[2] = 650 [ft/s]
 Vel[1] = 0 [ft/s]
 eta_nozzle = 0.85

"Conservation of Energy - SSSF energy balance for turbine -- neglecting the change in potential energy, no heat transfer:"

```

h[1]=enthalpy(WorkFluid$,T=T[1])
s[1]=entropy(WorkFluid$,P=P[1],T=T[1])
T_s[1] = T[1]
s[2] =s[1]
s_s[2] = s[1]
h_s[2]=enthalpy(WorkFluid$,T=T_s[2])
T_s[2]=temperature(WorkFluid$,P=P[2],s=s_s[2])
eta_nozzle = ke[2]/ke_s[2]
ke[1] = Vel[1]^2/2
ke[2]=Vel[2]^2/2
h[1]+ke[1]*convert(ft^2/s^2,Btu/lbm) = h[2] + ke[2]*convert(ft^2/s^2,Btu/lbm)
h[1] +ke[1]*convert(ft^2/s^2,Btu/lbm) = h_s[2] + ke_s[2]*convert(ft^2/s^2,Btu/lbm)
T[2]=temperature(WorkFluid$,h=h[2])
P_2_answer = P[2]
T_2_answer = T[2]
    
```

η_{nozzle}	P_2 [psia]	T_2 [F]	$T_{s,2}$ [F]
0.8	40.25	907.6	899.5
0.82	40.36	907.6	900.5
0.84	40.47	907.6	901.4
0.86	40.57	907.6	902.3
0.88	40.67	907.6	903.2
0.9	40.76	907.6	904
0.92	40.85	907.6	904.8
0.94	40.93	907.6	905.6
0.96	41.01	907.6	906.3
0.98	41.09	907.6	907
1	41.17	907.6	907.6

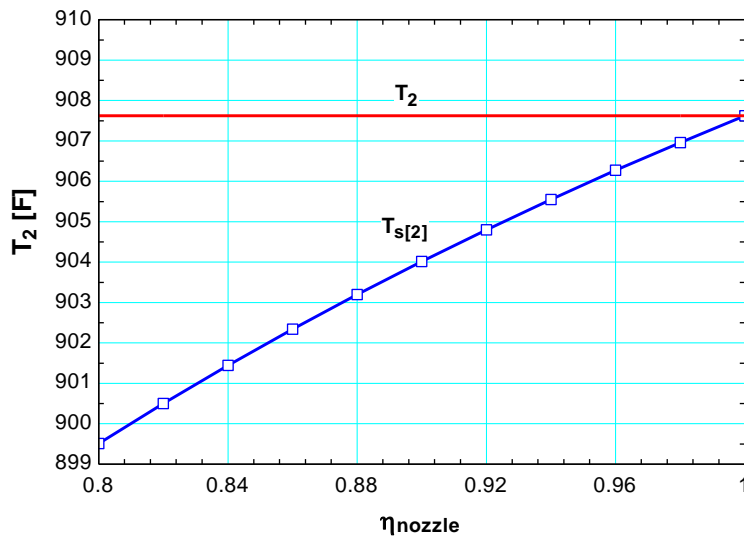
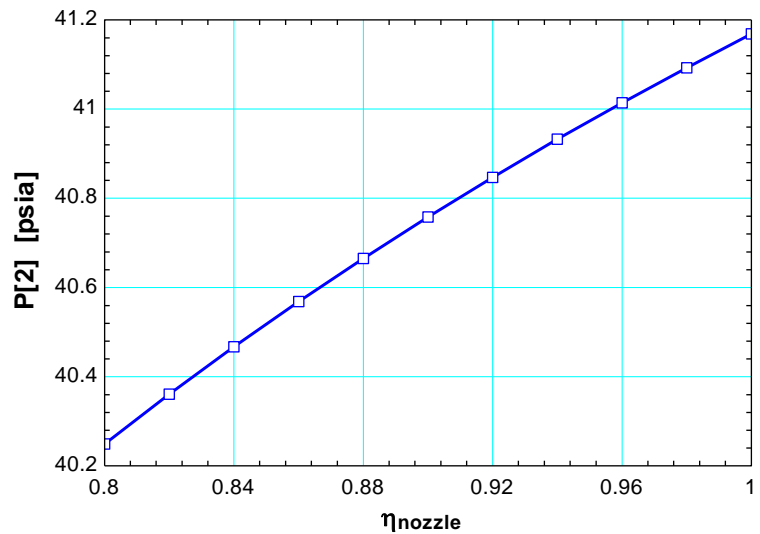

7-130 Air is expanded in an adiabatic nozzle with an isentropic efficiency of 0.96. The air velocity at the exit is to be determined.

Assumptions 1 This is a steady-flow process since there is no change with time. **2** There is no heat transfer or shaft work associated with the process. **3** Air is an ideal gas with constant specific heats.

Properties The properties of air at room temperature are $c_p = 1.005 \text{ kJ/kg} \cdot \text{K}$ and $k = 1.4$ (Table A-2a).

Analysis For the isentropic process of an ideal gas, the exit temperature is determined from

$$T_{2s} = T_1 \left(\frac{P_2}{P_1} \right)^{(k-1)/k} = (180 + 273 \text{ K}) \left(\frac{100 \text{ kPa}}{300 \text{ kPa}} \right)^{0.4/1.4} = 331.0 \text{ K}$$

There is only one inlet and one exit, and thus $\dot{m}_1 = \dot{m}_2 = \dot{m}$. We take nozzle as the system, which is a control volume since mass crosses the boundary. The energy balance for this steady-flow system can be expressed in the rate form as

$$\underbrace{\dot{E}_{\text{in}} - \dot{E}_{\text{out}}}_{\text{Rate of net energy transfer by heat, work, and mass}} = \underbrace{\Delta \dot{E}_{\text{system}}}_{\text{Rate of change in internal, kinetic, potential, etc. energies}} \stackrel{\text{no (steady)}}{=} 0$$

$$\dot{E}_{\text{in}} = \dot{E}_{\text{out}}$$

$$\dot{m} \left(h_1 + \frac{V_1^2}{2} \right) = \dot{m} \left(h_2 + \frac{V_2^2}{2} \right)$$

$$h_1 + \frac{V_1^2}{2} = h_2 + \frac{V_2^2}{2}$$

$$h_1 - h_2 = \frac{V_2^2 - V_1^2}{2}$$

$$c_p (T_1 - T_2) = \frac{V_2^2 - V_1^2}{2} = \Delta \text{ke}$$

The kinetic energy change for the isentropic case is

$$\Delta \text{ke}_s = c_p (T_1 - T_{2s}) = (1.005 \text{ kJ/kg} \cdot \text{K})(453 - 331) \text{ K} = 122.6 \text{ kJ/kg}$$

The kinetic energy change for the actual process is

$$\Delta \text{ke}_a = \eta_N \Delta \text{ke}_s = (0.96)(122.6 \text{ kJ/kg}) = 117.7 \text{ kJ/kg}$$

Substituting into the energy balance and solving for the exit velocity gives

$$V_2 = (\Delta \text{ke}_a)^{0.5} = \left[2(117.7 \text{ kJ/kg}) \left(\frac{1000 \text{ m}^2/\text{s}^2}{1 \text{ kJ/kg}} \right) \right]^{0.5} = \mathbf{485 \text{ m/s}}$$

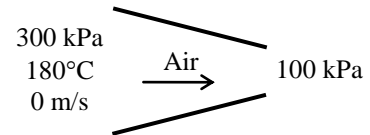

7-131E Air is decelerated in an adiabatic diffuser with an isentropic efficiency of 0.82. The air velocity at the exit is to be determined.

Assumptions 1 This is a steady-flow process since there is no change with time. **2** There is no heat transfer or shaft work associated with the process. **3** Air is an ideal gas with constant specific heats.

Properties The properties of air at room temperature are $c_p = 0.240$ Btu/lbm·R and $k = 1.4$ (Table A-2Ea).

Analysis For the isentropic process of an ideal gas, the exit temperature is determined from

$$T_{2s} = T_1 \left(\frac{P_2}{P_1} \right)^{(k-1)/k} = (30 + 460 \text{ R}) \left(\frac{20 \text{ psia}}{11 \text{ psia}} \right)^{0.4/1.4} = 581.3 \text{ R}$$

There is only one inlet and one exit, and thus $\dot{m}_1 = \dot{m}_2 = \dot{m}$. We take nozzle as the system, which is a control volume since mass crosses the boundary. The energy balance for this steady-flow system can be expressed in the rate form as

$$\underbrace{\dot{E}_{\text{in}} - \dot{E}_{\text{out}}}_{\substack{\text{Rate of net energy transfer} \\ \text{by heat, work, and mass}}} = \underbrace{\Delta \dot{E}_{\text{system}}}_{\substack{\text{Rate of change in internal, kinetic,} \\ \text{potential, etc. energies}}} \stackrel{\text{no (steady)}}{=} 0$$

$$\dot{E}_{\text{in}} = \dot{E}_{\text{out}}$$

$$\dot{m} \left(h_1 + \frac{V_1^2}{2} \right) = \dot{m} \left(h_2 + \frac{V_2^2}{2} \right)$$

$$h_1 + \frac{V_1^2}{2} = h_2 + \frac{V_2^2}{2}$$

$$h_1 - h_2 = \frac{V_2^2 - V_1^2}{2}$$

$$c_p (T_1 - T_2) = \frac{V_2^2 - V_1^2}{2} = \Delta \text{ke}$$

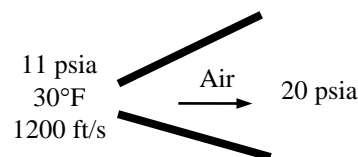

The kinetic energy change for the isentropic case is

$$\Delta \text{ke}_s = c_p (T_{2s} - T_1) = (0.240 \text{ Btu/lbm} \cdot \text{R})(581.3 - 490) \text{ R} = 21.90 \text{ Btu/lbm}$$

The kinetic energy change for the actual process is

$$\Delta \text{ke}_a = \eta_N \Delta \text{ke}_s = (0.82)(21.90 \text{ Btu/lbm}) = 17.96 \text{ Btu/lbm}$$

Substituting into the energy balance and solving for the exit velocity gives

$$V_2 = (V_1^2 - 2\Delta \text{ke}_a)^{0.5} = \left[(1200 \text{ ft/s})^2 - 2(17.96 \text{ Btu/lbm}) \left(\frac{25,037 \text{ ft}^2/\text{s}^2}{1 \text{ Btu/lbm}} \right) \right]^{0.5} = 735 \text{ ft/s}$$

7-132 Hot combustion gases are accelerated in a 92% efficient adiabatic nozzle from low velocity to a specified velocity. The exit velocity and the exit temperature are to be determined.

Assumptions 1 This is a steady-flow process since there is no change with time. **2** Potential energy changes are negligible. **3** The device is adiabatic and thus heat transfer is negligible. **4** Combustion gases can be treated as air that is an ideal gas with variable specific heats.

Analysis From the air table (Table A-17),

$$T_1 = 1020 \text{ K} \longrightarrow h_1 = 1068.89 \text{ kJ/kg}, P_{r_1} = 123.4$$

From the isentropic relation ,

$$P_{r_2} = \left(\frac{P_2}{P_1} \right) P_{r_1} = \left(\frac{85 \text{ kPa}}{260 \text{ kPa}} \right) (123.4) = 40.34 \longrightarrow h_{2s} = 783.92 \text{ kJ/kg}$$

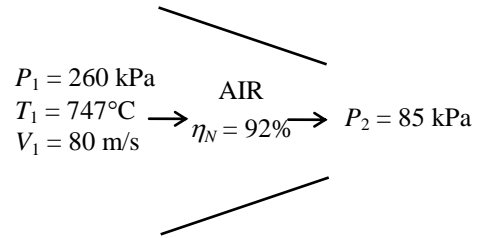

There is only one inlet and one exit, and thus $\dot{m}_1 = \dot{m}_2 = \dot{m}$. We take the nozzle as the system, which is a control volume since mass crosses the boundary. The energy balance for this steady-flow system for the isentropic process can be expressed as

$$\underbrace{\dot{E}_{\text{in}} - \dot{E}_{\text{out}}}_{\text{Rate of net energy transfer by heat, work, and mass}} = \underbrace{\Delta \dot{E}_{\text{system}}^{\neq 0} (\text{steady})}_{\text{Rate of change in internal, kinetic, potential, etc. energies}} = 0$$

$$\dot{E}_{\text{in}} = \dot{E}_{\text{out}}$$

$$\dot{m}(h_1 + V_1^2/2) = \dot{m}(h_{2s} + V_{2s}^2/2) \quad (\text{since } \dot{W} = \dot{Q} \cong \Delta p e \cong 0)$$

$$h_{2s} = h_1 - \frac{V_{2s}^2 - V_1^2}{2}$$

Then the isentropic exit velocity becomes

$$V_{2s} = \sqrt{V_1^2 + 2(h_1 - h_{2s})} = \sqrt{(80 \text{ m/s})^2 + 2(1068.89 - 783.92) \text{ kJ/kg} \left(\frac{1000 \text{ m}^2/\text{s}^2}{1 \text{ kJ/kg}} \right)} = 759.2 \text{ m/s}$$

Therefore,

$$V_{2a} = \sqrt{\eta_N} V_{2s} = \sqrt{0.92} (759.2 \text{ m/s}) = 728.2 \text{ m/s} \cong \mathbf{728 \text{ m/s}}$$

The exit temperature of air is determined from the steady-flow energy equation,

$$h_{2a} = 1068.89 \text{ kJ/kg} - \frac{(728.2 \text{ m/s})^2 - (80 \text{ m/s})^2}{2} \left(\frac{1 \text{ kJ/kg}}{1000 \text{ m}^2/\text{s}^2} \right) = 806.95 \text{ kJ/kg}$$

From the air table we read

$$T_{2a} = \mathbf{786 \text{ K}}$$

Entropy Balance

7-133E Refrigerant-134a is expanded adiabatically from a specified state to another. The entropy generation is to be determined.

Assumptions **1** Steady operating conditions exist. **2** Kinetic and potential energy changes are negligible.

Analysis The rate of entropy generation within the expansion device during this process can be determined by applying the rate form of the entropy balance on the system. Noting that the system is adiabatic and thus there is no heat transfer, the entropy balance for this steady-flow system can be expressed as

$$\underbrace{\dot{S}_{\text{in}} - \dot{S}_{\text{out}}}_{\text{Rate of net entropy transfer by heat and mass}} + \underbrace{\dot{S}_{\text{gen}}}_{\text{Rate of entropy generation}} = \underbrace{\Delta \dot{S}_{\text{system}}}_{\text{Rate of change of entropy}} \stackrel{\neq 0 \text{ (steady)}}{=} 0$$

$$\dot{m}_1 s_1 - \dot{m}_2 s_2 + \dot{S}_{\text{gen}} = 0$$

$$\dot{S}_{\text{gen}} = \dot{m}(s_2 - s_1)$$

$$s_{\text{gen}} = s_2 - s_1$$

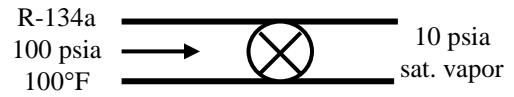

The properties of the refrigerant at the inlet and exit states are (Tables A-11E through A-13E)

$$\left. \begin{array}{l} P_1 = 100 \text{ psia} \\ T_1 = 100^\circ\text{F} \end{array} \right\} s_1 = 0.22902 \text{ Btu/lbm} \cdot \text{R}$$

$$\left. \begin{array}{l} P_2 = 10 \text{ psia} \\ x_2 = 1 \end{array} \right\} s_2 = 0.22949 \text{ Btu/lbm} \cdot \text{R}$$

Substituting,

$$s_{\text{gen}} = s_2 - s_1 = 0.22949 - 0.22902 = \mathbf{0.000475 \text{ Btu/lbm} \cdot \text{R}}$$

7-134 Oxygen is cooled as it flows in an insulated pipe. The rate of entropy generation in the pipe is to be determined.

Assumptions 1 Steady operating conditions exist. 2 The pipe is well-insulated so that heat loss to the surroundings is negligible. 3 Changes in the kinetic and potential energies are negligible. 4 Oxygen is an ideal gas with constant specific heats.

Properties The properties of oxygen at room temperature are $R = 0.2598 \text{ kJ/kg}\cdot\text{K}$, $c_p = 0.918 \text{ kJ/kg}\cdot\text{K}$ (Table A-2a).

Analysis The rate of entropy generation in the pipe is determined by applying the rate form of the entropy balance on the pipe:

$$\underbrace{\dot{S}_{\text{in}} - \dot{S}_{\text{out}}}_{\text{Rate of net entropy transfer by heat and mass}} + \underbrace{\dot{S}_{\text{gen}}}_{\text{Rate of entropy generation}} = \underbrace{\Delta\dot{S}_{\text{system}}}_{\text{Rate of change of entropy}} \stackrel{\neq 0 \text{ (steady)}}{=} 0$$

$$\dot{m}_1 s_1 - \dot{m}_2 s_2 + \dot{S}_{\text{gen}} = 0 \quad (\text{since } Q = 0)$$

$$\dot{S}_{\text{gen}} = \dot{m}(s_2 - s_1)$$

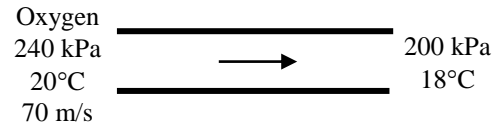

The specific volume of oxygen at the inlet and the mass flow rate are

$$\nu_1 = \frac{RT_1}{P_1} = \frac{(0.2598 \text{ kPa} \cdot \text{m}^3/\text{kg} \cdot \text{K})(293 \text{ K})}{240 \text{ kPa}} = 0.3172 \text{ m}^3/\text{kg}$$

$$\dot{m} = \frac{A_1 V_1}{\nu_1} = \frac{\pi D^2 V_1}{4 \nu_1} = \frac{\pi (0.12 \text{ m})^2 (70 \text{ m/s})}{4 (0.3172 \text{ m}^3/\text{kg})} = 2.496 \text{ kg/s}$$

Substituting into the entropy balance relation,

$$\begin{aligned} \dot{S}_{\text{gen}} &= \dot{m}(s_2 - s_1) \\ &= \dot{m} \left(c_p \ln \frac{T_2}{T_1} - R \ln \frac{P_2}{P_1} \right) \\ &= (2.496 \text{ kg/s}) \left[(0.918 \text{ kJ/kg} \cdot \text{K}) \ln \frac{291 \text{ K}}{293 \text{ K}} - (0.2598 \text{ kJ/kg} \cdot \text{K}) \ln \frac{200 \text{ kPa}}{240 \text{ kPa}} \right] \\ &= \mathbf{0.1025 \text{ kW/K}} \end{aligned}$$

7-135 Nitrogen is compressed by an adiabatic compressor. The entropy generation for this process is to be determined.

Assumptions **1** Steady operating conditions exist. **2** The compressor is well-insulated so that heat loss to the surroundings is negligible. **3** Changes in the kinetic and potential energies are negligible. **4** Nitrogen is an ideal gas with constant specific heats.

Properties The specific heat of nitrogen at the average temperature of $(25+290)/2=158^\circ\text{C} = 431\text{ K}$ is $c_p = 1.047\text{ kJ/kg}\cdot\text{K}$ (Table A-2b). Also, $R = 0.2968\text{ kJ/kg}\cdot\text{K}$ (Table A-2a).

Analysis The rate of entropy generation in the pipe is determined by applying the rate form of the entropy balance on the compressor:

$$\underbrace{\dot{S}_{\text{in}} - \dot{S}_{\text{out}}}_{\text{Rate of net entropy transfer by heat and mass}} + \underbrace{\dot{S}_{\text{gen}}}_{\text{Rate of entropy generation}} = \underbrace{\Delta\dot{S}_{\text{system}}}_{\text{Rate of change of entropy}} \stackrel{\neq 0 \text{ (steady)}}{=} 0$$

$$\dot{m}_1 s_1 - \dot{m}_2 s_2 + \dot{S}_{\text{gen}} = 0 \quad (\text{since } Q = 0)$$

$$\dot{S}_{\text{gen}} = \dot{m}(s_2 - s_1)$$

Substituting per unit mass of the oxygen,

$$s_{\text{gen}} = s_2 - s_1$$

$$= c_p \ln \frac{T_2}{T_1} - R \ln \frac{P_2}{P_1}$$

$$= (1.047\text{ kJ/kg}\cdot\text{K}) \ln \frac{(290 + 273)\text{ K}}{(25 + 273)\text{ K}} - (0.2968\text{ kJ/kg}\cdot\text{K}) \ln \frac{600\text{ kPa}}{100\text{ kPa}}$$

$$= \mathbf{0.134\text{ kJ/kg}\cdot\text{K}}$$

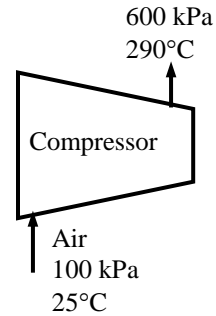

7-136 Heat is lost from the air that is being compressed in a compressor. The exit temperature of the air, the work input to the compressor, and the entropy generation during this process are to be determined.

Assumptions **1** Steady operating conditions exist. **2** Kinetic and potential energy changes are negligible. **3** Air is an ideal gas with constant specific heats.

Properties The gas constant of air is $R = 0.287 \text{ kPa}\cdot\text{m}^3/\text{kg}\cdot\text{K}$. Also, the specific heat at room temperature is $c_p = 1.005 \text{ kJ/kg}\cdot\text{K}$ (Table A-2).

Analysis (a) The exit temperature of the air may be determined from the relation for the entropy change of air

$$\Delta S_{\text{air}} = c_p \ln \frac{T_2}{T_{a1}} - R \ln \frac{P_2}{P_1}$$

$$-0.40 \text{ kJ/kg}\cdot\text{K} = (1.005 \text{ kJ/kg}\cdot\text{K}) \ln \frac{T_2}{(22 + 273) \text{ K}} - (0.287 \text{ kJ/kg}\cdot\text{K}) \ln \frac{800 \text{ kPa}}{100 \text{ kPa}}$$

$$T_2 = 358.8 \text{ K} = \mathbf{85.8^\circ\text{C}}$$

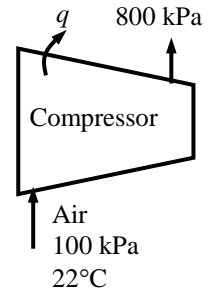

(b) The work input to the compressor is obtained from an energy balance on the compressor

$$w_{in} = c_p(T_2 - T_1) + q_{out} = (1.005 \text{ kJ/kg}\cdot^\circ\text{C})(85.8 - 22)^\circ\text{C} + 120 \text{ kJ/kg} = \mathbf{184.1 \text{ kJ/kg}}$$

(c) The entropy generation associated with this process may be obtained by adding the entropy change of air as it is compressed in the compressor and the entropy change of the surroundings

$$\Delta s_{\text{surr}} = \frac{q_{out}}{T_{\text{surr}}} = \frac{120 \text{ kJ/kg}}{(22 + 273) \text{ K}} = 0.4068 \text{ kJ/kg}\cdot\text{K}$$

$$s_{\text{gen}} = \Delta s_{\text{total}} = \Delta s_{\text{air}} + \Delta s_{\text{surr}} = -0.40 + 0.4068 = \mathbf{0.0068 \text{ kJ/kg}\cdot\text{K}}$$

7-137 A steam turbine for which the power output and the isentropic efficiency are given is considered. The mass flow rate of the steam, the temperature of the steam at the turbine exit, and the entropy generation are to be determined.

Assumptions 1 Steady operating conditions exist. 2 Potential energy changes are negligible.

Analysis (a) The properties of the steam at the inlet of the turbine and the enthalpy at the exit for the isentropic case are (Table A-6)

$$\left. \begin{aligned} P_1 &= 7 \text{ MPa} \\ T_1 &= 500^\circ\text{C} \end{aligned} \right\} \begin{aligned} h_1 &= 3411.4 \text{ kJ/kg} \\ s_1 &= 6.8000 \text{ kJ/kg}\cdot\text{K} \end{aligned}$$

$$\left. \begin{aligned} P_2 &= 100 \text{ kPa} \\ s_2 &= s_1 = 6.8000 \text{ kJ/kg}\cdot\text{K} \end{aligned} \right\} h_{2s} = 2466.6 \text{ kJ/kg}$$

The power output if the expansion was isentropic would be

$$\dot{W}_s = \frac{\dot{W}_a}{\eta_T} = \frac{5000 \text{ kW}}{0.77} = 6494 \text{ kW}$$

An energy balance on the turbine for the isentropic process may be used to determine the mass flow rate of the steam

$$\dot{m} \left(h_1 + \frac{V_1^2}{2} \right) = \dot{m} \left(h_{2s} + \frac{V_2^2}{2} \right) + \dot{W}_s$$

$$\dot{m} \left[3411.4 \text{ kJ/kg} + \frac{(45 \text{ m/s})^2}{2} \left(\frac{1 \text{ kJ/kg}}{1000 \text{ m}^2/\text{s}^2} \right) \right] = \dot{m} \left[2466.6 \text{ kJ/kg} + \frac{(75 \text{ m/s})^2}{2} \left(\frac{1 \text{ kJ/kg}}{1000 \text{ m}^2/\text{s}^2} \right) \right] + 6494 \text{ kW}$$

$$\dot{m} = \mathbf{6.886 \text{ kg/s}}$$

(b) An energy balance on the turbine for the actual process may be used to determine actual enthalpy at the exit

$$\dot{m} \left(h_1 + \frac{V_1^2}{2} \right) = \dot{m} \left(h_2 + \frac{V_2^2}{2} \right) + \dot{W}_a$$

$$(6.886 \text{ kg/s}) \left[3411.4 \text{ kJ/kg} + \frac{(45 \text{ m/s})^2}{2} \left(\frac{1 \text{ kJ/kg}}{1000 \text{ m}^2/\text{s}^2} \right) \right] = (6.886 \text{ kg/s}) \left[h_2 + \frac{(75 \text{ m/s})^2}{2} \left(\frac{1 \text{ kJ/kg}}{1000 \text{ m}^2/\text{s}^2} \right) \right] + 5000 \text{ kW}$$

$$h_2 = 2683.5 \text{ kJ/kg}$$

Now, other properties at the exit state may be obtained

$$\left. \begin{aligned} P_2 &= 100 \text{ kPa} \\ h_2 &= 2683.5 \text{ kJ/kg} \end{aligned} \right\} \begin{aligned} T_2 &= \mathbf{103.7^\circ\text{C}} \\ s_2 &= 7.3817 \text{ kJ/kg}\cdot\text{K} \end{aligned}$$

(c) Since the turbine is adiabatic, the entropy generation is the entropy change of steam as it flows in the turbine

$$\dot{S}_{\text{gen}} = \dot{m}(s_2 - s_1) = (6.886 \text{ kg/s})(7.3817 - 6.8000) \text{ kJ/kg}\cdot\text{K} = \mathbf{4.01 \text{ kW/K}}$$

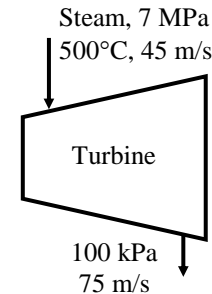

7-138 In an ice-making plant, water is frozen by evaporating saturated R-134a liquid. The rate of entropy generation is to be determined.

Assumptions 1 Steady operating conditions exist. 2 Kinetic and potential energy changes are negligible.

Analysis We take the control volume formed by the R-134a evaporator with a single inlet and single exit as the system. The rate of entropy generation within this evaporator during this process can be determined by applying the rate form of the entropy balance on the system. The entropy balance for this steady-flow system can be expressed as

$$\underbrace{\dot{S}_{\text{in}} - \dot{S}_{\text{out}}}_{\text{Rate of net entropy transfer by heat and mass}} + \underbrace{\dot{S}_{\text{gen}}}_{\text{Rate of entropy generation}} = \underbrace{\Delta\dot{S}_{\text{system}}}_{\text{Rate of change of entropy}} \stackrel{\neq 0 \text{ (steady)}}{=} 0$$

$$\dot{m}_1 s_1 - \dot{m}_2 s_2 + \frac{\dot{Q}_{\text{in}}}{T_w} + \dot{S}_{\text{gen}} = 0$$

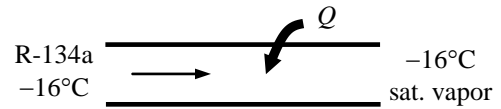

$$\dot{S}_{\text{gen}} = \dot{m}_R (s_2 - s_1) - \frac{\dot{Q}_{\text{in}}}{T_w}$$

$$\dot{S}_{\text{gen}} = \dot{m}_R s_{fg} - \frac{\dot{Q}_{\text{in}}}{T_w}$$

The properties of the refrigerant are (Table A-11)

$$h_{fg @ -16^\circ\text{C}} = 210.18 \text{ kJ/kg}$$

$$s_{fg @ -16^\circ\text{C}} = 0.81729 \text{ kJ/kg} \cdot \text{K}$$

The rate of that must be removed from the water in order to freeze it at a rate of 4000 kg/h is

$$\dot{Q}_{\text{in}} = \dot{m}_w h_{if} = (2500 / 3600 \text{ kg/s})(333.7 \text{ kJ/kg}) = 231.7 \text{ kW}$$

where the heat of fusion of water at 1 atm is 333.7 kJ/kg. The mass flow rate of R-134a is

$$\dot{m}_R = \frac{\dot{Q}_{\text{in}}}{h_{fg}} = \frac{231.7 \text{ kJ/s}}{210.18 \text{ kJ/kg}} = 1.103 \text{ kg/s}$$

Substituting,

$$\dot{S}_{\text{gen}} = \dot{m}_R s_{fg} - \frac{\dot{Q}_{\text{in}}}{T_w} = (1.103 \text{ kg/s})(0.81729 \text{ kJ/kg} \cdot \text{K}) - \frac{231.7 \text{ kW}}{273 \text{ K}} = \mathbf{0.0528 \text{ kW/K}}$$

7-139E Water and steam are mixed in a chamber that is losing heat at a specified rate. The rate of entropy generation during this process is to be determined.

Assumptions 1 This is a steady-flow process since there is no change with time at any point and thus $\Delta m_{CV} = 0$, $\Delta E_{CV} = 0$, and $\Delta S_{CV} = 0$. **2** There are no work interactions involved. **3** The kinetic and potential energies are negligible, $ke = pe = 0$.

Analysis We take the *mixing chamber* as the system. This is a *control volume* since mass crosses the system boundary during the process.

We note that there are two inlets and one exit. Under the stated assumptions and observations, the mass and energy balances for this steady-flow system can be expressed in the rate form as follows:

Mass balance:

$$\dot{m}_{in} - \dot{m}_{out} = \Delta \dot{m}_{system} \stackrel{\text{no (steady)}}{=} 0$$

$$\dot{m}_{in} = \dot{m}_{out} \longrightarrow \dot{m}_1 + \dot{m}_2 = \dot{m}_3$$

Energy balance:

$$\underbrace{\dot{E}_{in} - \dot{E}_{out}}_{\text{Rate of net energy transfer by heat, work, and mass}} = \underbrace{\Delta \dot{E}_{system}}_{\text{Rate of change in internal, kinetic, potential, etc. energies}} \stackrel{\text{no (steady)}}{=} 0$$

$$\dot{E}_{in} = \dot{E}_{out}$$

$$\dot{m}_1 h_1 + \dot{m}_2 h_2 = \dot{m}_3 h_3 + \dot{Q}_{out}$$

Combining the mass and energy balances gives

$$\dot{Q}_{out} = \dot{m}_1 h_1 + \dot{m}_2 h_2 - (\dot{m}_1 + \dot{m}_2) h_3$$

The desired properties at the specified states are determined from the steam tables to be

$$\left. \begin{array}{l} P_1 = 20 \text{ psia} \\ T_1 = 50^\circ\text{F} \end{array} \right\} \begin{array}{l} h_1 = h_f @ 50^\circ\text{F} = 18.07 \text{ Btu/lbm} \\ s_1 = s_f @ 50^\circ\text{F} = 0.03609 \text{ Btu/lbm} \cdot \text{R} \end{array}$$

$$\left. \begin{array}{l} P_2 = 20 \text{ psia} \\ T_2 = 240^\circ\text{F} \end{array} \right\} \begin{array}{l} h_2 = 1162.3 \text{ Btu/lbm} \\ s_2 = 1.7406 \text{ Btu/lbm} \cdot \text{R} \end{array}$$

$$\left. \begin{array}{l} P_3 = 20 \text{ psia} \\ T_3 = 130^\circ\text{F} \end{array} \right\} \begin{array}{l} h_3 = h_f @ 130^\circ\text{F} = 97.99 \text{ Btu/lbm} \\ s_3 = s_f @ 130^\circ\text{F} = 0.18174 \text{ Btu/lbm} \cdot \text{R} \end{array}$$

Substituting,

$$180 \text{ Btu/min} = [300 \times 18.07 + \dot{m}_2 \times 1162.3 - (300 + \dot{m}_2) \times 97.99] \text{ Btu/min} \longrightarrow \dot{m}_2 = 22.7 \text{ lbm/min}$$

The rate of entropy generation during this process can be determined by applying the rate form of the entropy balance on an *extended system* that includes the mixing chamber and its immediate surroundings so that the boundary temperature of the extended system is $70^\circ\text{F} = 530 \text{ R}$:

$$\underbrace{\dot{S}_{in} - \dot{S}_{out}}_{\text{Rate of net entropy transfer by heat and mass}} + \underbrace{\dot{S}_{gen}}_{\text{Rate of entropy generation}} = \underbrace{\Delta \dot{S}_{system}}_{\text{Rate of change of entropy}} \stackrel{\text{no (steady)}}{=} 0$$

$$\dot{m}_1 s_1 + \dot{m}_2 s_2 - \dot{m}_3 s_3 - \frac{\dot{Q}_{out}}{T_b} + \dot{S}_{gen} = 0$$

Substituting, the rate of entropy generation is determined to be

$$\dot{S}_{gen} = \dot{m}_3 s_3 - \dot{m}_1 s_1 - \dot{m}_2 s_2 + \frac{\dot{Q}_{out}}{T_b}$$

$$= (322.7 \times 0.18174 - 300 \times 0.03609 - 22.7 \times 1.7406) \text{ Btu/min} \cdot \text{R} + \frac{180 \text{ Btu/min}}{530 \text{ R}}$$

$$= \mathbf{8.65 \text{ Btu/min} \cdot \text{R}}$$

Discussion Note that entropy is generated during this process at a rate of $8.65 \text{ Btu/min} \cdot \text{R}$. This entropy generation is caused by the mixing of two fluid streams (an irreversible process) and the heat transfer between the mixing chamber and the surroundings through a finite temperature difference (another irreversible process).

7-140E Steam is condensed by cooling water in a condenser. The rate of heat transfer and the rate of entropy generation within the heat exchanger are to be determined.

Assumptions 1 Steady operating conditions exist. 2 The heat exchanger is well-insulated so that heat loss to the surroundings is negligible and thus heat transfer from the hot fluid is equal to the heat transfer to the cold fluid. 3 Changes in the kinetic and potential energies of fluid streams are negligible. 4 Fluid properties are constant.

Properties The specific heat of water is 1.0 Btu/lbm·°F (Table A-3E).

The enthalpy and entropy of vaporization of water at 150°F are $h_{fg} = 1007.8$ Btu/lbm and $s_{fg} = 1.6529$ Btu/lbm·R (Table A-4E).

Analysis We take the tube-side of the heat exchanger where cold water is flowing as the system, which is a control volume. The energy balance for this steady-flow system can be expressed in the rate form as

$$\underbrace{\dot{E}_{in} - \dot{E}_{out}}_{\text{Rate of net energy transfer by heat, work, and mass}} = \underbrace{\Delta \dot{E}_{system}^{\approx 0} \text{ (steady)}}_{\text{Rate of change in internal, kinetic, potential, etc. energies}} = 0$$

$$\dot{E}_{in} = \dot{E}_{out}$$

$$\dot{Q}_{in} + \dot{m}h_1 = \dot{m}h_2 \quad (\text{since } \Delta ke \cong \Delta pe \cong 0)$$

$$\dot{Q}_{in} = \dot{m}c_p(T_2 - T_1)$$

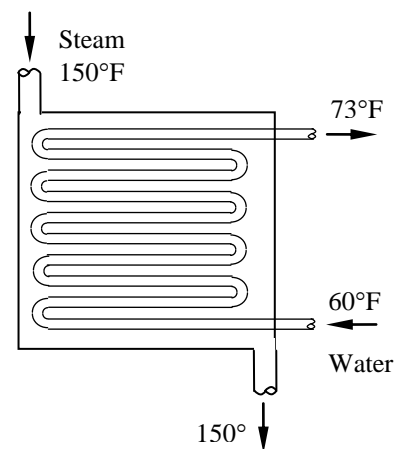

Then the rate of heat transfer to the cold water in this heat exchanger becomes

$$\dot{Q} = [\dot{m}c_p(T_{out} - T_{in})]_{\text{water}} = (44 \text{ lbm/s})(1.0 \text{ Btu/lbm}\cdot\text{°F})(73\text{°F} - 60\text{°F}) = \mathbf{572.0 \text{ Btu/s}}$$

Noting that heat gain by the water is equal to the heat loss by the condensing steam, the rate of condensation of the steam in the heat exchanger is determined from

$$\dot{Q} = (\dot{m}h_{fg})_{\text{steam}} \longrightarrow \dot{m}_{\text{steam}} = \frac{\dot{Q}}{h_{fg}} = \frac{572.0 \text{ Btu/s}}{1007.8 \text{ Btu/lbm}} = 0.5676 \text{ lbm/s}$$

(b) The rate of entropy generation within the heat exchanger is determined by applying the rate form of the entropy balance on the entire heat exchanger:

$$\underbrace{\dot{S}_{in} - \dot{S}_{out}}_{\text{Rate of net entropy transfer by heat and mass}} + \underbrace{\dot{S}_{gen}}_{\text{Rate of entropy generation}} = \underbrace{\Delta \dot{S}_{system}^{\approx 0} \text{ (steady)}}_{\text{Rate of change of entropy}}$$

$$\dot{m}_1s_1 + \dot{m}_3s_3 - \dot{m}_2s_2 - \dot{m}_4s_4 + \dot{S}_{gen} = 0 \quad (\text{since } \dot{Q} = 0)$$

$$\dot{m}_{\text{water}}s_1 + \dot{m}_{\text{steam}}s_3 - \dot{m}_{\text{water}}s_2 - \dot{m}_{\text{steam}}s_4 + \dot{S}_{gen} = 0$$

$$\dot{S}_{gen} = \dot{m}_{\text{water}}(s_2 - s_1) + \dot{m}_{\text{steam}}(s_4 - s_3)$$

Noting that water is an incompressible substance and steam changes from saturated vapor to saturated liquid, the rate of entropy generation is determined to be

$$\dot{S}_{gen} = \dot{m}_{\text{water}}c_p \ln \frac{T_2}{T_1} + \dot{m}_{\text{steam}}(s_f - s_g) = \dot{m}_{\text{water}}c_p \ln \frac{T_2}{T_1} - \dot{m}_{\text{steam}}s_{fg}$$

$$= (44 \text{ lbm/s})(1.0 \text{ Btu/lbm}\cdot\text{R}) \ln \frac{73 + 460}{60 + 460} - (0.5676 \text{ lbm/s})(1.6529 \text{ Btu/lbm}\cdot\text{R})$$

$$= \mathbf{0.148 \text{ Btu/s}\cdot\text{R}}$$

7-141 Water is heated in a heat exchanger by geothermal water. The rate of heat transfer to the water and the rate of entropy generation within the heat exchanger are to be determined.

Assumptions 1 Steady operating conditions exist. 2 The heat exchanger is well-insulated so that heat loss to the surroundings is negligible and thus heat transfer from the hot fluid is equal to the heat transfer to the cold fluid. 3 Changes in the kinetic and potential energies of fluid streams are negligible. 4 Fluid properties are constant.

Properties The specific heats of water and geothermal fluid are given to be 4.18 and 4.31 kJ/kg·°C, respectively.

Analysis (a) We take the cold water tubes as the system, which is a control volume.

The energy balance for this steady-flow system can be expressed in the rate form as

$$\underbrace{\dot{E}_{\text{in}} - \dot{E}_{\text{out}}}_{\text{Rate of net energy transfer by heat, work, and mass}} = \underbrace{\Delta \dot{E}_{\text{system}}^{\text{0 (steady)}}}_{\text{Rate of change in internal, kinetic, potential, etc. energies}} = 0$$

$$\dot{E}_{\text{in}} = \dot{E}_{\text{out}}$$

$$\dot{Q}_{\text{in}} + \dot{m}h_1 = \dot{m}h_2 \quad (\text{since } \Delta \text{ke} \cong \Delta \text{pe} \cong 0)$$

$$\dot{Q}_{\text{in}} = \dot{m}C_p(T_2 - T_1)$$

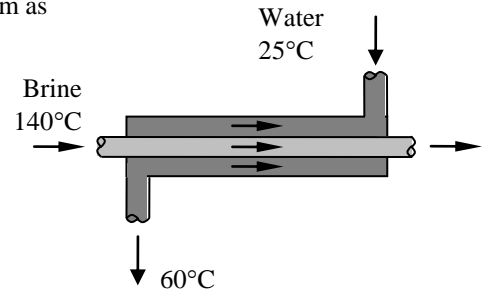

Then the rate of heat transfer to the cold water in the heat exchanger becomes

$$\dot{Q}_{\text{in, water}} = [\dot{m}c_p(T_{\text{out}} - T_{\text{in}})]_{\text{water}} = (0.50 \text{ kg/s})(4.18 \text{ kJ/kg}\cdot\text{°C})(60\text{°C} - 25\text{°C}) = \mathbf{73.15 \text{ kW}}$$

Noting that heat transfer to the cold water is equal to the heat loss from the geothermal water, the outlet temperature of the geothermal water is determined from

$$\dot{Q}_{\text{out}} = [\dot{m}c_p(T_{\text{in}} - T_{\text{out}})]_{\text{geot. water}} \longrightarrow T_{\text{out}} = T_{\text{in}} - \frac{\dot{Q}_{\text{out}}}{\dot{m}c_p}$$

$$= 140\text{°C} - \frac{73.15 \text{ kW}}{(0.75 \text{ kg/s})(4.31 \text{ kJ/kg}\cdot\text{°C})} = 117.4\text{°C}$$

(b) The rate of entropy generation within the heat exchanger is determined by applying the rate form of the entropy balance on the entire heat exchanger:

$$\underbrace{\dot{S}_{\text{in}} - \dot{S}_{\text{out}}}_{\text{Rate of net entropy transfer by heat and mass}} + \underbrace{\dot{S}_{\text{gen}}}_{\text{Rate of entropy generation}} = \underbrace{\Delta \dot{S}_{\text{system}}^{\text{0 (steady)}}}_{\text{Rate of change of entropy}}$$

$$\dot{m}_1 s_1 + \dot{m}_3 s_3 - \dot{m}_2 s_2 - \dot{m}_4 s_4 + \dot{S}_{\text{gen}} = 0 \quad (\text{since } \dot{Q} = 0)$$

$$\dot{m}_{\text{water}} s_1 + \dot{m}_{\text{geo}} s_3 - \dot{m}_{\text{water}} s_2 - \dot{m}_{\text{geo}} s_4 + \dot{S}_{\text{gen}} = 0$$

$$\dot{S}_{\text{gen}} = \dot{m}_{\text{water}}(s_2 - s_1) + \dot{m}_{\text{geo}}(s_4 - s_3)$$

Noting that both fresh and geothermal water are incompressible substances, the rate of entropy generation is determined to be

$$\dot{S}_{\text{gen}} = \dot{m}_{\text{water}} c_p \ln \frac{T_2}{T_1} + \dot{m}_{\text{geo}} c_p \ln \frac{T_4}{T_3}$$

$$= (0.50 \text{ kg/s})(4.18 \text{ kJ/kg}\cdot\text{K}) \ln \frac{60 + 273}{25 + 273} + (0.75 \text{ kg/s})(4.31 \text{ kJ/kg}\cdot\text{K}) \ln \frac{117.4 + 273}{140 + 273} = \mathbf{0.050 \text{ kW/K}}$$

7-142 Ethylene glycol is cooled by water in a heat exchanger. The rate of heat transfer and the rate of entropy generation within the heat exchanger are to be determined.

Assumptions 1 Steady operating conditions exist. 2 The heat exchanger is well-insulated so that heat loss to the surroundings is negligible and thus heat transfer from the hot fluid is equal to the heat transfer to the cold fluid. 3 Changes in the kinetic and potential energies of fluid streams are negligible. 4 Fluid properties are constant.

Properties The specific heats of water and ethylene glycol are given to be 4.18 and 2.56 kJ/kg·°C, respectively.

Analysis (a) We take the ethylene glycol tubes as the system, which is a control volume. The energy balance for this steady-flow system can be expressed in the rate form as

$$\underbrace{\dot{E}_{\text{in}} - \dot{E}_{\text{out}}}_{\text{Rate of net energy transfer by heat, work, and mass}} = \underbrace{\Delta \dot{E}_{\text{system}}^{\neq 0} (\text{steady})}_{\text{Rate of change in internal, kinetic, potential, etc. energies}} = 0$$

$$\dot{E}_{\text{in}} = \dot{E}_{\text{out}}$$

$$\dot{m}h_1 = \dot{Q}_{\text{out}} + \dot{m}h_2 \quad (\text{since } \Delta ke \cong \Delta pe \cong 0)$$

$$\dot{Q}_{\text{out}} = \dot{m}c_p(T_1 - T_2)$$

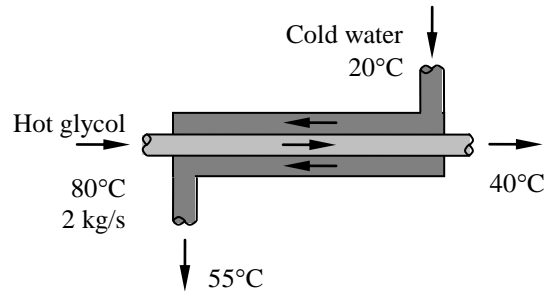

Then the rate of heat transfer becomes

$$\dot{Q}_{\text{out}} = [\dot{m}c_p(T_{\text{in}} - T_{\text{out}})]_{\text{glycol}} = (2 \text{ kg/s})(2.56 \text{ kJ/kg}\cdot\text{°C})(80\text{°C} - 40\text{°C}) = \mathbf{204.8 \text{ kW}}$$

The rate of heat transfer from water must be equal to the rate of heat transfer to the glycol. Then,

$$\dot{Q}_{\text{in}} = [\dot{m}c_p(T_{\text{out}} - T_{\text{in}})]_{\text{water}} \longrightarrow \dot{m}_{\text{water}} = \frac{\dot{Q}_{\text{in}}}{c_p(T_{\text{out}} - T_{\text{in}})}$$

$$= \frac{204.8 \text{ kJ/s}}{(4.18 \text{ kJ/kg}\cdot\text{°C})(55\text{°C} - 20\text{°C})} = 1.4 \text{ kg/s}$$

(b) The rate of entropy generation within the heat exchanger is determined by applying the rate form of the entropy balance on the entire heat exchanger:

$$\underbrace{\dot{S}_{\text{in}} - \dot{S}_{\text{out}}}_{\text{Rate of net entropy transfer by heat and mass}} + \underbrace{\dot{S}_{\text{gen}}}_{\text{Rate of entropy generation}} = \underbrace{\Delta \dot{S}_{\text{system}}^{\neq 0} (\text{steady})}_{\text{Rate of change of entropy}}$$

$$\dot{m}_1 s_1 + \dot{m}_3 s_3 - \dot{m}_2 s_2 - \dot{m}_4 s_4 + \dot{S}_{\text{gen}} = 0 \quad (\text{since } \dot{Q} = 0)$$

$$\dot{m}_{\text{glycol}} s_1 + \dot{m}_{\text{water}} s_3 - \dot{m}_{\text{glycol}} s_2 - \dot{m}_{\text{water}} s_4 + \dot{S}_{\text{gen}} = 0$$

$$\dot{S}_{\text{gen}} = \dot{m}_{\text{glycol}}(s_2 - s_1) + \dot{m}_{\text{water}}(s_4 - s_3)$$

Noting that both fluid streams are liquids (incompressible substances), the rate of entropy generation is determined to be

$$\dot{S}_{\text{gen}} = \dot{m}_{\text{glycol}} c_p \ln \frac{T_2}{T_1} + \dot{m}_{\text{water}} c_p \ln \frac{T_4}{T_3}$$

$$= (2 \text{ kg/s})(2.56 \text{ kJ/kg}\cdot\text{K}) \ln \frac{40 + 273}{80 + 273} + (1.4 \text{ kg/s})(4.18 \text{ kJ/kg}\cdot\text{K}) \ln \frac{55 + 273}{20 + 273}$$

$$= \mathbf{0.0446 \text{ kW/K}}$$

7-143 Oil is to be cooled by water in a thin-walled heat exchanger. The rate of heat transfer and the rate of entropy generation within the heat exchanger are to be determined.

Assumptions 1 Steady operating conditions exist. 2 The heat exchanger is well-insulated so that heat loss to the surroundings is negligible and thus heat transfer from the hot fluid is equal to the heat transfer to the cold fluid. 3 Changes in the kinetic and potential energies of fluid streams are negligible. 4 Fluid properties are constant.

Properties The specific heats of water and oil are given to be 4.18 and 2.20 kJ/kg·°C, respectively.

Analysis We take the oil tubes as the system, which is a control volume. The energy balance for this steady-flow system can be expressed in the rate form as

$$\underbrace{\dot{E}_{\text{in}} - \dot{E}_{\text{out}}}_{\substack{\text{Rate of net energy transfer} \\ \text{by heat, work, and mass}}} = \underbrace{\Delta \dot{E}_{\text{system}}^{\text{0 (steady)}}}_{\substack{\text{Rate of change in internal, kinetic,} \\ \text{potential, etc. energies}}} = 0$$

$$\dot{E}_{\text{in}} = \dot{E}_{\text{out}}$$

$$\dot{m}h_1 = \dot{Q}_{\text{out}} + \dot{m}h_2 \quad (\text{since } \Delta \text{ke} \cong \Delta \text{pe} \cong 0)$$

$$\dot{Q}_{\text{out}} = \dot{m}c_p(T_1 - T_2)$$

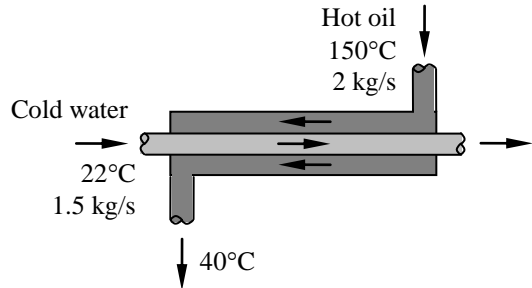

Then the rate of heat transfer from the oil becomes

$$\dot{Q}_{\text{out}} = [\dot{m}c_p(T_{\text{in}} - T_{\text{out}})]_{\text{oil}} = (2 \text{ kg/s})(2.2 \text{ kJ/kg}\cdot\text{°C})(150\text{°C} - 40\text{°C}) = \mathbf{484 \text{ kW}}$$

Noting that the heat lost by the oil is gained by the water, the outlet temperature of the water is determined from

$$\dot{Q}_{\text{in}} = [\dot{m}c_p(T_{\text{out}} - T_{\text{in}})]_{\text{water}} \longrightarrow T_{\text{out}} = T_{\text{in}} + \frac{\dot{Q}_{\text{in}}}{\dot{m}c_p} = 20\text{°C} + \frac{484 \text{ kW}}{(1.5 \text{ kg/s})(4.18 \text{ kJ/kg}\cdot\text{°C})} = 99.2\text{°C}$$

(b) The rate of entropy generation within the heat exchanger is determined by applying the rate form of the entropy balance on the entire heat exchanger:

$$\underbrace{\dot{S}_{\text{in}} - \dot{S}_{\text{out}}}_{\substack{\text{Rate of net entropy transfer} \\ \text{by heat and mass}}} + \underbrace{\dot{S}_{\text{gen}}}_{\substack{\text{Rate of entropy} \\ \text{generation}}} = \underbrace{\Delta \dot{S}_{\text{system}}^{\text{0 (steady)}}}_{\substack{\text{Rate of change} \\ \text{of entropy}}}$$

$$\dot{m}_1 s_1 + \dot{m}_3 s_3 - \dot{m}_2 s_2 - \dot{m}_4 s_4 + \dot{S}_{\text{gen}} = 0 \quad (\text{since } \dot{Q} = 0)$$

$$\dot{m}_{\text{oil}} s_1 + \dot{m}_{\text{water}} s_3 - \dot{m}_{\text{oil}} s_2 - \dot{m}_{\text{water}} s_4 + \dot{S}_{\text{gen}} = 0$$

$$\dot{S}_{\text{gen}} = \dot{m}_{\text{oil}}(s_2 - s_1) + \dot{m}_{\text{water}}(s_4 - s_3)$$

Noting that both fluid streams are liquids (incompressible substances), the rate of entropy generation is determined to be

$$\dot{S}_{\text{gen}} = \dot{m}_{\text{oil}} c_p \ln \frac{T_2}{T_1} + \dot{m}_{\text{water}} c_p \ln \frac{T_4}{T_3}$$

$$= (2 \text{ kg/s})(2.2 \text{ kJ/kg}\cdot\text{K}) \ln \frac{40 + 273}{150 + 273} + (1.5 \text{ kg/s})(4.18 \text{ kJ/kg}\cdot\text{K}) \ln \frac{99.2 + 273}{22 + 273}$$

$$= \mathbf{0.132 \text{ kW/K}}$$

7-144 A regenerator is considered to save heat during the cooling of milk in a dairy plant. The amounts of fuel and money such a generator will save per year and the annual reduction in the rate of entropy generation are to be determined.

Assumptions 1 Steady operating conditions exist. 2 The properties of the milk are constant.

Properties The average density and specific heat of milk can be taken to be $\rho_{\text{milk}} \cong \rho_{\text{water}} = 1 \text{ kg/L}$ and $c_{p, \text{milk}} = 3.79 \text{ kJ/kg}\cdot^\circ\text{C}$ (Table A-3).

Analysis The mass flow rate of the milk is

$$\begin{aligned}\dot{m}_{\text{milk}} &= \rho \dot{V}_{\text{milk}} \\ &= (1 \text{ kg/L})(12 \text{ L/s}) = 12 \text{ kg/s} = 43,200 \text{ kg/h}\end{aligned}$$

Taking the pasteurizing section as the system, the energy balance for this steady-flow system can be expressed in the rate form as

$$\begin{aligned}\underbrace{\dot{E}_{\text{in}} - \dot{E}_{\text{out}}}_{\text{Rate of net energy transfer by heat, work, and mass}} &= \underbrace{\Delta \dot{E}_{\text{system}}}_{\text{Rate of change in internal, kinetic, potential, etc. energies}} \stackrel{\neq 0 \text{ (steady)}}{=} 0 \rightarrow \dot{E}_{\text{in}} = \dot{E}_{\text{out}} \\ \dot{Q}_{\text{in}} + \dot{m}h_1 &= \dot{m}h_2 \quad (\text{since } \Delta ke \cong \Delta pe \cong 0) \\ \dot{Q}_{\text{in}} &= \dot{m}_{\text{milk}} c_p (T_2 - T_1)\end{aligned}$$

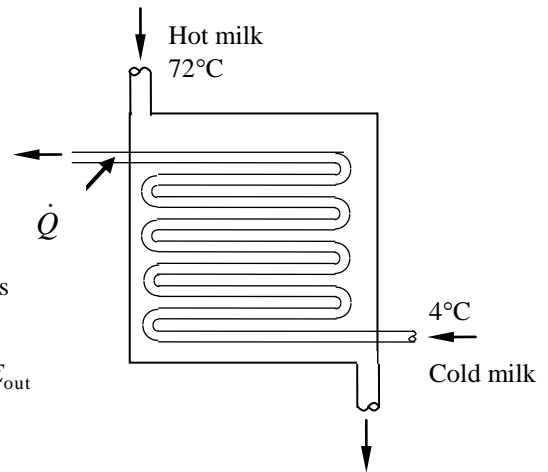

Therefore, to heat the milk from 4 to 72°C as being done currently, heat must be transferred to the milk at a rate of

$$\dot{Q}_{\text{current}} = [\dot{m}c_p(T_{\text{pasteurization}} - T_{\text{refrigeration}})]_{\text{milk}} = (12 \text{ kg/s})(3.79 \text{ kJ/kg}\cdot^\circ\text{C})(72 - 4)^\circ\text{C} = 3093 \text{ kJ/s}$$

The proposed regenerator has an effectiveness of $\varepsilon = 0.82$, and thus it will save 82 percent of this energy. Therefore,

$$\dot{Q}_{\text{saved}} = \varepsilon \dot{Q}_{\text{current}} = (0.82)(3093 \text{ kJ/s}) = 2536 \text{ kJ/s}$$

Noting that the boiler has an efficiency of $\eta_{\text{boiler}} = 0.82$, the energy savings above correspond to fuel savings of

$$\text{Fuel Saved} = \frac{\dot{Q}_{\text{saved}}}{\eta_{\text{boiler}}} = \frac{(2536 \text{ kJ/s})}{(0.82)} \frac{(1 \text{ therm})}{(105,500 \text{ kJ})} = 0.02931 \text{ therm/s}$$

Noting that 1 year = 365×24=8760 h and unit cost of natural gas is \$0.52/therm, the annual fuel and money savings will be

$$\text{Fuel Saved} = (0.02931 \text{ therms/s})(8760 \times 3600 \text{ s}) = \mathbf{924,450 \text{ therms/yr}}$$

$$\text{Money saved} = (\text{Fuel saved})(\text{Unit cost of fuel}) = (924,450 \text{ therm/yr})(\$1.30/\text{therm}) = \mathbf{\$1,201,800/\text{yr}}$$

The rate of entropy generation during this process is determined by applying the rate form of the entropy balance on an *extended system* that includes the regenerator and the immediate surroundings so that the boundary temperature is the surroundings temperature, which we take to be the cold water temperature of 18°C.:

$$\underbrace{\dot{S}_{\text{in}} - \dot{S}_{\text{out}}}_{\text{Rate of net entropy transfer by heat and mass}} + \underbrace{\dot{S}_{\text{gen}}}_{\text{Rate of entropy generation}} = \underbrace{\Delta \dot{S}_{\text{system}}}_{\text{Rate of change of entropy}} \stackrel{\neq 0 \text{ (steady)}}{=} 0 \rightarrow \dot{S}_{\text{gen}} = \dot{S}_{\text{out}} - \dot{S}_{\text{in}}$$

Disregarding entropy transfer associated with fuel flow, the only significant difference between the two cases is the reduction is the entropy transfer to water due to the reduction in heat transfer to water, and is determined to be

$$\dot{S}_{\text{gen, reduction}} = \dot{S}_{\text{out, reduction}} = \frac{\dot{Q}_{\text{out, reduction}}}{T_{\text{surr}}} = \frac{\dot{Q}_{\text{saved}}}{T_{\text{surr}}} = \frac{2536 \text{ kJ/s}}{18 + 273} = 8.715 \text{ kW/K}$$

$$S_{\text{gen, reduction}} = \dot{S}_{\text{gen, reduction}} \Delta t = (8.715 \text{ kJ/s}\cdot\text{K})(8760 \times 3600 \text{ s/year}) = \mathbf{2.75 \times 10^8 \text{ kJ/K (per year)}}$$

7-145 An egg is dropped into boiling water. The amount of heat transfer to the egg by the time it is cooked and the amount of entropy generation associated with this heat transfer process are to be determined.

Assumptions 1 The egg is spherical in shape with a radius of $r_0 = 2.75$ cm. **2** The thermal properties of the egg are constant. **3** Energy absorption or release associated with any chemical and/or phase changes within the egg is negligible. **4** There are no changes in kinetic and potential energies.

Properties The density and specific heat of the egg are given to be $\rho = 1020$ kg/m³ and $c_p = 3.32$ kJ/kg·°C.

Analysis We take the egg as the system. This is a closed system since no mass enters or leaves the egg. The energy balance for this closed system can be expressed as

$$\underbrace{E_{\text{in}} - E_{\text{out}}}_{\substack{\text{Net energy transfer} \\ \text{by heat, work, and mass}}} = \underbrace{\Delta E_{\text{system}}}_{\substack{\text{Change in internal, kinetic,} \\ \text{potential, etc. energies}}}$$

$$Q_{\text{in}} = \Delta U_{\text{egg}} = m(u_2 - u_1) = mc(T_2 - T_1)$$

Then the mass of the egg and the amount of heat transfer become

$$m = \rho V = \rho \frac{\pi D^3}{6} = (1020 \text{ kg/m}^3) \frac{\pi (0.055 \text{ m})^3}{6} = 0.0889 \text{ kg}$$

$$Q_{\text{in}} = mc_p(T_2 - T_1) = (0.0889 \text{ kg})(3.32 \text{ kJ/kg}\cdot\text{°C})(70 - 8)\text{°C} = \mathbf{18.3 \text{ kJ}}$$

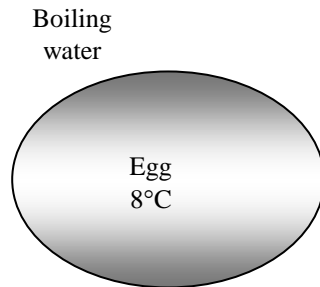

We again take a single egg as the system. The entropy generated during this process can be determined by applying an entropy balance on an *extended system* that includes the egg and its immediate surroundings so that the boundary temperature of the extended system is at 97°C at all times:

$$\underbrace{S_{\text{in}} - S_{\text{out}}}_{\substack{\text{Net entropy transfer} \\ \text{by heat and mass}}} + \underbrace{S_{\text{gen}}}_{\substack{\text{Entropy} \\ \text{generation}}} = \underbrace{\Delta S_{\text{system}}}_{\substack{\text{Change} \\ \text{in entropy}}}$$

$$\frac{Q_{\text{in}}}{T_b} + S_{\text{gen}} = \Delta S_{\text{system}} \rightarrow S_{\text{gen}} = -\frac{Q_{\text{in}}}{T_b} + \Delta S_{\text{system}}$$

where

$$\Delta S_{\text{system}} = m(s_2 - s_1) = mc_{\text{avg}} \ln \frac{T_2}{T_1} = (0.0889 \text{ kg})(3.32 \text{ kJ/kg}\cdot\text{K}) \ln \frac{70 + 273}{8 + 273} = 0.0588 \text{ kJ/K}$$

Substituting,

$$S_{\text{gen}} = -\frac{Q_{\text{in}}}{T_b} + \Delta S_{\text{system}} = -\frac{18.3 \text{ kJ}}{370 \text{ K}} + 0.0588 \text{ kJ/K} = \mathbf{0.00934 \text{ kJ/K}} \quad (\text{per egg})$$

7-146 Chickens are to be cooled by chilled water in an immersion chiller that is also gaining heat from the surroundings. The rate of heat removal from the chicken and the rate of entropy generation during this process are to be determined.

Assumptions 1 Steady operating conditions exist. 2 Thermal properties of chickens and water are constant. 3 The temperature of the surrounding medium is given to be 25°C.

Properties The specific heat of chicken is given to be 3.54 kJ/kg·°C. The specific heat of water at room temperature is 4.18 kJ/kg·°C (Table A-3).

Analysis (a) Chickens can be considered to flow steadily through the chiller at a mass flow rate of

$$\dot{m}_{\text{chicken}} = (250 \text{ chicken/h})(2.2 \text{ kg/chicken}) = 550 \text{ kg/h} = 0.1528 \text{ kg/s}$$

Taking the chicken flow stream in the chiller as the system, the energy balance for steadily flowing chickens can be expressed in the rate form as

$$\underbrace{\dot{E}_{\text{in}} - \dot{E}_{\text{out}}}_{\text{Rate of net energy transfer by heat, work, and mass}} = \underbrace{\Delta \dot{E}_{\text{system}}}_{\text{Rate of change in internal, kinetic, potential, etc. energies}} \stackrel{\approx 0 \text{ (steady)}}{=} 0 \rightarrow \dot{E}_{\text{in}} = \dot{E}_{\text{out}}$$

$$\dot{m}h_1 = \dot{Q}_{\text{out}} + \dot{m}h_2 \quad (\text{since } \Delta \text{ke} \cong \Delta \text{pe} \cong 0)$$

$$\dot{Q}_{\text{out}} = \dot{Q}_{\text{chicken}} = \dot{m}_{\text{chicken}} c_p (T_1 - T_2)$$

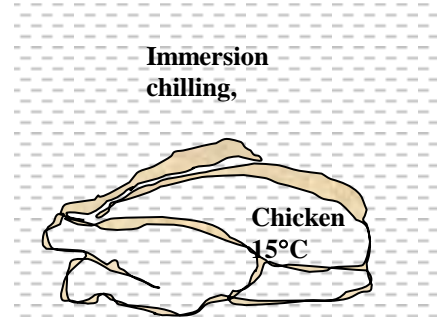

Then the rate of heat removal from the chickens as they are cooled from 15°C to 3°C becomes

$$\dot{Q}_{\text{chicken}} = (\dot{m} c_p \Delta T)_{\text{chicken}} = (0.1528 \text{ kg/s})(3.54 \text{ kJ/kg}\cdot\text{°C})(15 - 3)^\circ\text{C} = \mathbf{6.49 \text{ kW}}$$

The chiller gains heat from the surroundings as a rate of 150 kJ/h = 0.0417 kJ/s. Then the total rate of heat gain by the water is

$$\dot{Q}_{\text{water}} = \dot{Q}_{\text{chicken}} + \dot{Q}_{\text{heat gain}} = 6.49 + 0.0417 = 6.532 \text{ kW}$$

Noting that the temperature rise of water is not to exceed 2°C as it flows through the chiller, the mass flow rate of water must be at least

$$\dot{m}_{\text{water}} = \frac{\dot{Q}_{\text{water}}}{(c_p \Delta T)_{\text{water}}} = \frac{6.532 \text{ kW}}{(4.18 \text{ kJ/kg}\cdot\text{°C})(2^\circ\text{C})} = 0.781 \text{ kg/s}$$

(b) The rate of entropy generation is determined by applying the entropy balance on an *extended system* that includes the chiller and the immediate surroundings so that boundary temperature is the surroundings temperature:

$$\underbrace{\dot{S}_{\text{in}} - \dot{S}_{\text{out}}}_{\text{Rate of net entropy transfer by heat and mass}} + \underbrace{\dot{S}_{\text{gen}}}_{\text{Rate of entropy generation}} = \underbrace{\Delta \dot{S}_{\text{system}}}_{\text{Rate of change of entropy}} \stackrel{\approx 0 \text{ (steady)}}{=}$$

$$\dot{m}_1 s_1 + \dot{m}_3 s_3 - \dot{m}_2 s_2 - \dot{m}_3 s_4 + \frac{\dot{Q}_{\text{in}}}{T_{\text{surr}}} + \dot{S}_{\text{gen}} = 0$$

$$\dot{m}_{\text{chicken}} s_1 + \dot{m}_{\text{water}} s_3 - \dot{m}_{\text{chicken}} s_2 - \dot{m}_{\text{water}} s_4 + \frac{\dot{Q}_{\text{in}}}{T_{\text{surr}}} + \dot{S}_{\text{gen}} = 0$$

$$\dot{S}_{\text{gen}} = \dot{m}_{\text{chicken}}(s_2 - s_1) + \dot{m}_{\text{water}}(s_4 - s_3) - \frac{\dot{Q}_{\text{in}}}{T_{\text{surr}}}$$

Noting that both streams are incompressible substances, the rate of entropy generation is determined to be

$$\dot{S}_{\text{gen}} = \dot{m}_{\text{chicken}} c_p \ln \frac{T_2}{T_1} + \dot{m}_{\text{water}} c_p \ln \frac{T_4}{T_3} - \frac{\dot{Q}_{\text{in}}}{T_{\text{surr}}}$$

$$= (0.1528 \text{ kg/s})(3.54 \text{ kJ/kg}\cdot\text{K}) \ln \frac{276}{288} + (0.781 \text{ kg/s})(4.18 \text{ kJ/kg}\cdot\text{K}) \ln \frac{275.5}{273.5} - \frac{0.0417 \text{ kW}}{298 \text{ K}}$$

$$= \mathbf{0.000625 \text{ kW/K}}$$

7-147 Carbon steel balls are to be annealed at a rate of 2500/h by heating them first and then allowing them to cool slowly in ambient air at a specified rate. The total rate of heat transfer from the balls to the ambient air and the rate of entropy generation due to this heat transfer are to be determined.

Assumptions 1 The thermal properties of the balls are constant. **2** There are no changes in kinetic and potential energies. **3** The balls are at a uniform temperature at the end of the process

Properties The density and specific heat of the balls are given to be $\rho = 7833 \text{ kg/m}^3$ and $c_p = 0.465 \text{ kJ/kg}\cdot^\circ\text{C}$.

Analysis (a) We take a single ball as the system. The energy balance for this closed system can be expressed as

$$\underbrace{E_{\text{in}} - E_{\text{out}}}_{\substack{\text{Net energy transfer} \\ \text{by heat, work, and mass}}} = \underbrace{\Delta E_{\text{system}}}_{\substack{\text{Change in internal, kinetic,} \\ \text{potential, etc. energies}}}$$

$$-Q_{\text{out}} = \Delta U_{\text{ball}} = m(u_2 - u_1)$$

$$Q_{\text{out}} = mc(T_1 - T_2)$$

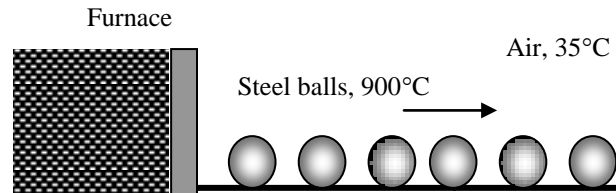

The amount of heat transfer from a single ball is

$$m = \rho V = \rho \frac{\pi D^3}{6} = (7833 \text{ kg/m}^3) \frac{\pi (0.008 \text{ m})^3}{6} = 0.00210 \text{ kg}$$

$$Q_{\text{out}} = mc_p(T_1 - T_2) = (0.0021 \text{ kg})(0.465 \text{ kJ/kg}\cdot^\circ\text{C})(900 - 100)^\circ\text{C} = 781 \text{ J} = 0.781 \text{ kJ (per ball)}$$

Then the total rate of heat transfer from the balls to the ambient air becomes

$$\dot{Q}_{\text{out}} = \dot{n}_{\text{ball}} Q_{\text{out}} = (2500 \text{ balls/h}) \times (0.781 \text{ kJ/ball}) = 1,953 \text{ kJ/h} = \mathbf{542 \text{ W}}$$

(b) We again take a single ball as the system. The entropy generated during this process can be determined by applying an entropy balance on an *extended system* that includes the ball and its immediate surroundings so that the boundary temperature of the extended system is at 35°C at all times:

$$\underbrace{S_{\text{in}} - S_{\text{out}}}_{\substack{\text{Net entropy transfer} \\ \text{by heat and mass}}} + \underbrace{S_{\text{gen}}}_{\substack{\text{Entropy} \\ \text{generation}}} = \underbrace{\Delta S_{\text{system}}}_{\substack{\text{Change} \\ \text{in entropy}}}$$

$$-\frac{Q_{\text{out}}}{T_b} + S_{\text{gen}} = \Delta S_{\text{system}} \rightarrow S_{\text{gen}} = \frac{Q_{\text{out}}}{T_b} + \Delta S_{\text{system}}$$

where

$$\Delta S_{\text{system}} = m(s_2 - s_1) = mc_{\text{avg}} \ln \frac{T_2}{T_1} = (0.00210 \text{ kg})(0.465 \text{ kJ/kg}\cdot\text{K}) \ln \frac{100 + 273}{900 + 273} = -0.00112 \text{ kJ/K}$$

Substituting,

$$S_{\text{gen}} = \frac{Q_{\text{out}}}{T_b} + \Delta S_{\text{system}} = \frac{0.781 \text{ kJ}}{308 \text{ K}} - 0.00112 \text{ kJ/K} = 0.00142 \text{ kJ/K (per ball)}$$

Then the rate of entropy generation becomes

$$\dot{S}_{\text{gen}} = S_{\text{gen}} \dot{n}_{\text{ball}} = (0.00142 \text{ kJ/K}\cdot\text{ball})(2500 \text{ balls/h}) = 3.55 \text{ kJ/h}\cdot\text{K} = \mathbf{0.986 \text{ W/K}}$$

7-148E Large brass plates are heated in an oven at a specified rate. The rate of heat transfer to the plates in the oven and the rate of entropy generation associated with this heat transfer process are to be determined.

Assumptions 1 The thermal properties of the plates are constant. **2** The changes in kinetic and potential energies are negligible.

Properties The density and specific heat of the brass are given to be $\rho = 532.5 \text{ lbm/ft}^3$ and $c_p = 0.091 \text{ Btu/lbm}\cdot^\circ\text{F}$.

Analysis We take the plate to be the system. The energy balance for this closed system can be expressed as

$$\underbrace{E_{\text{in}} - E_{\text{out}}}_{\substack{\text{Net energy transfer} \\ \text{by heat, work, and mass}}} = \underbrace{\Delta E_{\text{system}}}_{\substack{\text{Change in internal, kinetic,} \\ \text{potential, etc. energies}}}$$

$$Q_{\text{in}} = \Delta U_{\text{plate}} = m(u_2 - u_1) = mc(T_2 - T_1)$$

Plates
75°F

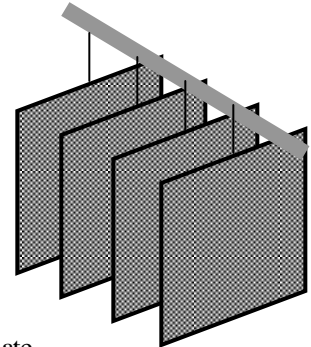

The mass of each plate and the amount of heat transfer to each plate is

$$m = \rho V = \rho LA = (532.5 \text{ lbm/ft}^3)[(1.2/12 \text{ ft})(2 \text{ ft})(2 \text{ ft})] = 213 \text{ lbm}$$

$$Q_{\text{in}} = mc(T_2 - T_1) = (213 \text{ lbm/plate})(0.091 \text{ Btu/lbm}\cdot^\circ\text{F})(1000 - 75)^\circ\text{F} = 17,930 \text{ Btu/plate}$$

Then the total rate of heat transfer to the plates becomes

$$\dot{Q}_{\text{total}} = \dot{n}_{\text{plate}} Q_{\text{in, per plate}} = (450 \text{ plates/min}) \times (17,930 \text{ Btu/plate}) = \mathbf{8,069,000 \text{ Btu/min} = 134,500 \text{ Btu/s}}$$

We again take a single plate as the system. The entropy generated during this process can be determined by applying an entropy balance on an *extended system* that includes the plate and its immediate surroundings so that the boundary temperature of the extended system is at 1300°F at all times:

$$\underbrace{S_{\text{in}} - S_{\text{out}}}_{\substack{\text{Net entropy transfer} \\ \text{by heat and mass}}} + \underbrace{S_{\text{gen}}}_{\substack{\text{Entropy} \\ \text{generation}}} = \underbrace{\Delta S_{\text{system}}}_{\substack{\text{Change} \\ \text{in entropy}}}$$

$$\frac{Q_{\text{in}}}{T_b} + S_{\text{gen}} = \Delta S_{\text{system}} \rightarrow S_{\text{gen}} = -\frac{Q_{\text{in}}}{T_b} + \Delta S_{\text{system}}$$

where

$$\Delta S_{\text{system}} = m(s_2 - s_1) = mc_{\text{avg}} \ln \frac{T_2}{T_1} = (213 \text{ lbm})(0.091 \text{ Btu/lbm}\cdot\text{R}) \ln \frac{1000 + 460}{75 + 460} = 19.46 \text{ Btu/R}$$

Substituting,

$$S_{\text{gen}} = -\frac{Q_{\text{in}}}{T_b} + \Delta S_{\text{system}} = -\frac{17,930 \text{ Btu}}{1300 + 460 \text{ R}} + 19.46 \text{ Btu/R} = 9.272 \text{ Btu/R (per plate)}$$

Then the rate of entropy generation becomes

$$\dot{S}_{\text{gen}} = S_{\text{gen}} \dot{n}_{\text{ball}} = (9.272 \text{ Btu/R} \cdot \text{plate})(450 \text{ plates/min}) = 4172 \text{ Btu/min}\cdot\text{R} = \mathbf{69.5 \text{ Btu/s}\cdot\text{R}}$$

7-149 Long cylindrical steel rods are heat-treated in an oven. The rate of heat transfer to the rods in the oven and the rate of entropy generation associated with this heat transfer process are to be determined.

Assumptions 1 The thermal properties of the rods are constant. **2** The changes in kinetic and potential energies are negligible.

Properties The density and specific heat of the steel rods are given to be $\rho = 7833 \text{ kg/m}^3$ and $c_p = 0.465 \text{ kJ/kg}\cdot^\circ\text{C}$.

Analysis (a) Noting that the rods enter the oven at a velocity of 3 m/min and exit at the same velocity, we can say that a 3-m long section of the rod is heated in the oven in 1 min. Then the mass of the rod heated in 1 minute is

$$\begin{aligned} m &= \rho V = \rho LA = \rho L(\pi D^2 / 4) \\ &= (7833 \text{ kg/m}^3)(3 \text{ m})[\pi(0.1 \text{ m})^2 / 4] \\ &= 184.6 \text{ kg} \end{aligned}$$

We take the 3-m section of the rod in the oven as the system. The energy balance for this closed system can be expressed as

$$\underbrace{E_{\text{in}} - E_{\text{out}}}_{\substack{\text{Net energy transfer} \\ \text{by heat, work, and mass}}} = \underbrace{\Delta E_{\text{system}}}_{\substack{\text{Change in internal, kinetic,} \\ \text{potential, etc. energies}}}$$

$$Q_{\text{in}} = \Delta U_{\text{rod}} = m(u_2 - u_1) = mc(T_2 - T_1)$$

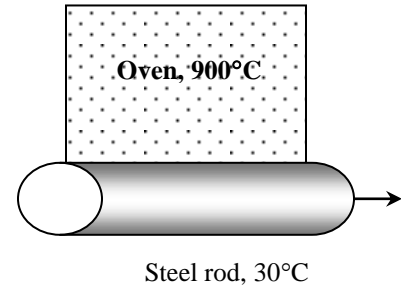

Substituting,

$$Q_{\text{in}} = mc(T_2 - T_1) = (184.6 \text{ kg})(0.465 \text{ kJ/kg}\cdot^\circ\text{C})(700 - 30)^\circ\text{C} = 57,512 \text{ kJ}$$

Noting that this much heat is transferred in 1 min, the rate of heat transfer to the rod becomes

$$\dot{Q}_{\text{in}} = Q_{\text{in}} / \Delta t = (57,512 \text{ kJ}) / (1 \text{ min}) = 57,512 \text{ kJ/min} = \mathbf{958.5 \text{ kW}}$$

(b) We again take the 3-m long section of the rod as the system. The entropy generated during this process can be determined by applying an entropy balance on an *extended system* that includes the rod and its immediate surroundings so that the boundary temperature of the extended system is at 900°C at all times:

$$\underbrace{S_{\text{in}} - S_{\text{out}}}_{\substack{\text{Net entropy transfer} \\ \text{by heat and mass}}} + \underbrace{S_{\text{gen}}}_{\substack{\text{Entropy} \\ \text{generation}}} = \underbrace{\Delta S_{\text{system}}}_{\substack{\text{Change} \\ \text{in entropy}}}$$

$$\frac{Q_{\text{in}}}{T_b} + S_{\text{gen}} = \Delta S_{\text{system}} \rightarrow S_{\text{gen}} = -\frac{Q_{\text{in}}}{T_b} + \Delta S_{\text{system}}$$

where

$$\Delta S_{\text{system}} = m(s_2 - s_1) = mc_{\text{avg}} \ln \frac{T_2}{T_1} = (184.6 \text{ kg})(0.465 \text{ kJ/kg}\cdot\text{K}) \ln \frac{700 + 273}{30 + 273} = 100.1 \text{ kJ/K}$$

Substituting,

$$S_{\text{gen}} = -\frac{Q_{\text{in}}}{T_b} + \Delta S_{\text{system}} = -\frac{57,512 \text{ kJ}}{900 + 273 \text{ K}} + 100.1 \text{ kJ/K} = 51.1 \text{ kJ/K}$$

Noting that this much entropy is generated in 1 min, the rate of entropy generation becomes

$$\dot{S}_{\text{gen}} = \frac{S_{\text{gen}}}{\Delta t} = \frac{51.1 \text{ kJ/K}}{1 \text{ min}} = 51.1 \text{ kJ/min}\cdot\text{K} = \mathbf{0.85 \text{ kW/K}}$$

7-150 The inner and outer surfaces of a brick wall are maintained at specified temperatures. The rate of entropy generation within the wall is to be determined.

Assumptions Steady operating conditions exist since the surface temperatures of the wall remain constant at the specified values.

Analysis We take the wall to be the system, which is a closed system. Under steady conditions, the rate form of the entropy balance for the wall simplifies to

$$\underbrace{\dot{S}_{\text{in}} - \dot{S}_{\text{out}}}_{\text{Rate of net entropy transfer by heat and mass}} + \underbrace{\dot{S}_{\text{gen}}}_{\text{Rate of entropy generation}} = \underbrace{\Delta\dot{S}_{\text{system}}}_{\text{Rate of change of entropy}} \stackrel{\neq 0}{=} 0$$

$$\frac{\dot{Q}_{\text{in}}}{T_{\text{b,in}}} - \frac{\dot{Q}_{\text{out}}}{T_{\text{b,out}}} + \dot{S}_{\text{gen,wall}} = 0$$

$$\frac{1250 \text{ W}}{289 \text{ K}} - \frac{1250 \text{ W}}{277 \text{ K}} + \dot{S}_{\text{gen,wall}} = 0$$

$$\dot{S}_{\text{gen,wall}} = \mathbf{0.187 \text{ W/K}}$$

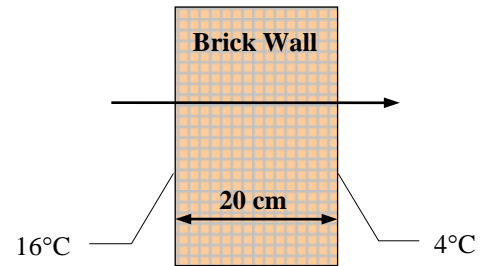

Therefore, the rate of entropy generation in the wall is 0.187 W/K.

7-151E A cylinder contains saturated liquid water at a specified pressure. Heat is transferred to liquid from a source and some liquid evaporates. The total entropy generation during this process is to be determined.

Assumptions 1 No heat loss occurs from the water to the surroundings during the process. **2** The pressure inside the cylinder and thus the water temperature remains constant during the process. **3** No irreversibilities occur within the cylinder during the process.

Analysis The pressure of the steam is maintained constant. Therefore, the temperature of the steam remains constant also at

$$T = T_{\text{sat}@40 \text{ psia}} = 267.2^\circ\text{F} = 727.2 \text{ R} \quad (\text{Table A-5E})$$

Taking the contents of the cylinder as the system and noting that the temperature of water remains constant, the entropy change of the system during this isothermal, internally reversible process becomes

$$\Delta S_{\text{system}} = \frac{Q_{\text{sys,in}}}{T_{\text{sys}}} = \frac{600 \text{ Btu}}{727.2 \text{ R}} = 0.8251 \text{ Btu/R}$$

Similarly, the entropy change of the heat source is determined from

$$\Delta S_{\text{source}} = -\frac{Q_{\text{source,out}}}{T_{\text{source}}} = -\frac{600 \text{ Btu}}{1000 + 460 \text{ R}} = -0.4110 \text{ Btu/R}$$

Now consider a combined system that includes the cylinder and the source. Noting that no heat or mass crosses the boundaries of this combined system, the entropy balance for it can be expressed as

$$\underbrace{S_{\text{in}} - S_{\text{out}}}_{\text{Net entropy transfer by heat and mass}} + \underbrace{S_{\text{gen}}}_{\text{Entropy generation}} = \underbrace{\Delta S_{\text{system}}}_{\text{Change in entropy}}$$

$$0 + S_{\text{gen,total}} = \Delta S_{\text{water}} + \Delta S_{\text{source}}$$

Therefore, the total entropy generated during this process is

$$S_{\text{gen,total}} = \Delta S_{\text{water}} + \Delta S_{\text{source}} = 0.8251 - 0.4110 = \mathbf{0.414 \text{ Btu/R}}$$

Discussion The entropy generation in this case is entirely due to the irreversible heat transfer through a finite temperature difference. We could also determine the total entropy generation by writing an energy balance on an extended system that includes the system and its immediate surroundings so that part of the boundary of the extended system, where heat transfer occurs, is at the source temperature.

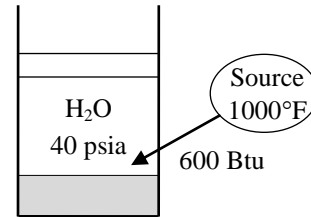

7-152E Steam is decelerated in a diffuser from a velocity of 900 ft/s to 100 ft/s. The mass flow rate of steam and the rate of entropy generation are to be determined.

Assumptions 1 This is a steady-flow process since there is no change with time. **2** Potential energy changes are negligible. **3** There are no work interactions.

Properties The properties of steam at the inlet and the exit of the diffuser are (Tables A-4E through A-6E)

$$\left. \begin{array}{l} P_1 = 20 \text{ psia} \\ T_1 = 240^\circ\text{F} \end{array} \right\} \begin{array}{l} h_1 = 1162.3 \text{ Btu/lbm} \\ s_1 = 1.7406 \text{ Btu/lbm}\cdot\text{R} \end{array}$$

$$\left. \begin{array}{l} T_2 = 240^\circ\text{F} \\ \text{sat. vapor} \end{array} \right\} \begin{array}{l} h_2 = 1160.5 \text{ Btu/lbm} \\ s_2 = 1.7141 \text{ Btu/lbm}\cdot\text{R} \\ v_2 = 16.316 \text{ ft}^3/\text{lbm} \end{array}$$

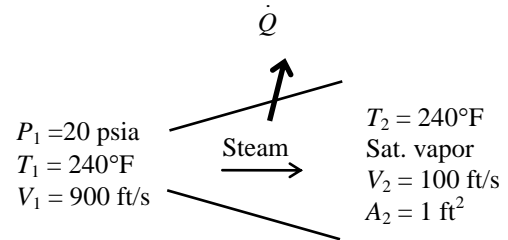

Analysis (a) The mass flow rate of the steam can be determined from its definition to be

$$\dot{m} = \frac{1}{v_2} A_2 V_2 = \frac{1}{16.316 \text{ ft}^3/\text{lbm}} (1 \text{ ft}^2)(100 \text{ ft/s}) = \mathbf{6.129 \text{ lbm/s}}$$

(b) We take diffuser as the system, which is a control volume since mass crosses the boundary. The energy balance for this steady-flow system can be expressed in the rate form as

$$\underbrace{\dot{E}_{\text{in}} - \dot{E}_{\text{out}}}_{\text{Rate of net energy transfer by heat, work, and mass}} = \underbrace{\Delta \dot{E}_{\text{system}}}_{\text{Rate of change in internal, kinetic, potential, etc. energies}} \stackrel{\neq 0}{\text{(steady)}} = 0$$

$$\dot{E}_{\text{in}} = \dot{E}_{\text{out}}$$

$$\dot{m}(h_1 + V_1^2/2) - \dot{Q}_{\text{out}} = \dot{m}(h_2 + V_2^2/2) \quad (\text{since } \dot{W} \cong \Delta \text{pe} \cong 0)$$

$$\dot{Q}_{\text{out}} = -\dot{m} \left(h_2 - h_1 + \frac{V_2^2 - V_1^2}{2} \right)$$

Substituting, the rate of heat loss from the diffuser is determined to be

$$\dot{Q}_{\text{out}} = -(6.129 \text{ lbm/s}) \left(1160.5 - 1162.3 + \frac{(100 \text{ ft/s})^2 - (900 \text{ ft/s})^2}{2} \left(\frac{1 \text{ Btu/lbm}}{25,037 \text{ ft}^2/\text{s}^2} \right) \right) = 108.42 \text{ Btu/s}$$

The rate of total entropy generation during this process is determined by applying the entropy balance on an *extended system* that includes the diffuser and its immediate surroundings so that the boundary temperature of the extended system is 77°F at all times. It gives

$$\underbrace{\dot{S}_{\text{in}} - \dot{S}_{\text{out}}}_{\text{Rate of net entropy transfer by heat and mass}} + \underbrace{\dot{S}_{\text{gen}}}_{\text{Rate of entropy generation}} = \underbrace{\Delta \dot{S}_{\text{system}}}_{\text{Rate of change of entropy}} \stackrel{\neq 0}{=} 0$$

$$\dot{m}s_1 - \dot{m}s_2 - \frac{\dot{Q}_{\text{out}}}{T_{\text{b,surr}}} + \dot{S}_{\text{gen}} = 0$$

Substituting, the total rate of entropy generation during this process becomes

$$\dot{S}_{\text{gen}} = \dot{m}(s_2 - s_1) + \frac{\dot{Q}_{\text{out}}}{T_{\text{b,surr}}} = (6.129 \text{ lbm/s})(1.7141 - 1.7406) \text{ Btu/lbm}\cdot\text{R} + \frac{108.42 \text{ Btu/s}}{537 \text{ R}} = \mathbf{0.0395 \text{ Btu/s}\cdot\text{R}}$$

7-153 Steam is accelerated in a nozzle from a velocity of 55 m/s to 390 m/s. The exit temperature and the rate of entropy generation are to be determined.

Assumptions 1 This is a steady-flow process since there is no change with time. **2** Potential energy changes are negligible. **3** There are no work interactions. **4** The device is adiabatic and thus heat transfer is negligible.

Properties From the steam tables (Table A-6),

$$\left. \begin{array}{l} P_1 = 2 \text{ MPa} \\ T_1 = 350 \text{ }^\circ\text{C} \end{array} \right\} \begin{array}{l} h_1 = 3137.7 \text{ kJ/kg} \\ s_1 = 6.9583 \text{ kJ/kg} \cdot \text{K} \\ \nu_1 = 0.13860 \text{ m}^3/\text{kg} \end{array}$$

Analysis (a) There is only one inlet and one exit, and thus $\dot{m}_1 = \dot{m}_2 = \dot{m}$. We take nozzle as the system, which is a control volume since mass crosses the boundary. The energy balance for this steady-flow system can be expressed in the rate form as

$$\underbrace{\dot{E}_{\text{in}} - \dot{E}_{\text{out}}}_{\text{Rate of net energy transfer by heat, work, and mass}} = \underbrace{\Delta \dot{E}_{\text{system}}^{\text{no}}}_{\text{Rate of change in internal, kinetic, potential, etc. energies}} \stackrel{\text{no}}{\text{steady}} = 0$$

$$\dot{E}_{\text{in}} = \dot{E}_{\text{out}}$$

$$\dot{m}(h_1 + V_1^2/2) = \dot{m}(h_2 + V_2^2/2) \quad (\text{since } \dot{Q} \equiv \dot{W} \equiv \Delta \text{pe} \equiv 0)$$

$$0 = h_2 - h_1 + \frac{V_2^2 - V_1^2}{2}$$

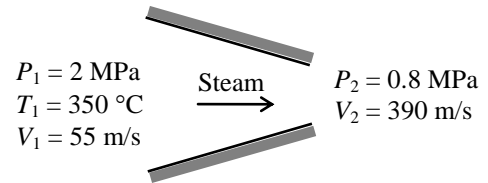

Substituting,

$$h_2 = 3137.7 \text{ kJ/kg} - \frac{(390 \text{ m/s})^2 - (55 \text{ m/s})^2}{2} \left(\frac{1 \text{ kJ/kg}}{1000 \text{ m}^2/\text{s}^2} \right) = 3063.1 \text{ kJ/kg}$$

Thus,

$$\left. \begin{array}{l} P_2 = 0.8 \text{ MPa} \\ h_{2a} = 3063.1 \text{ kJ/kg} \end{array} \right\} \begin{array}{l} T_2 = \mathbf{303^\circ\text{C}} \\ s_2 = 7.2454 \text{ kJ/kg} \cdot \text{K} \end{array}$$

The mass flow rate of steam is

$$\dot{m} = \frac{1}{\nu_1} A_1 V_1 = \frac{1}{0.13860 \text{ m}^3/\text{kg}} (7.5 \times 10^{-4} \text{ m}^2) (55 \text{ m/s}) = 0.2976 \text{ kg/s}$$

(b) Again we take the nozzle to be the system. Noting that no heat crosses the boundaries of this combined system, the entropy balance for it can be expressed as

$$\underbrace{\dot{S}_{\text{in}} - \dot{S}_{\text{out}}}_{\text{Rate of net entropy transfer by heat and mass}} + \underbrace{\dot{S}_{\text{gen}}}_{\text{Rate of entropy generation}} = \underbrace{\Delta \dot{S}_{\text{system}}^{\text{no}}}_{\text{Rate of change of entropy}} = 0$$

$$\dot{m}s_1 - \dot{m}s_2 + \dot{S}_{\text{gen}} = 0$$

$$\dot{S}_{\text{gen}} = \dot{m}(s_2 - s_1)$$

Substituting, the rate of entropy generation during this process is determined to be

$$\dot{S}_{\text{gen}} = \dot{m}(s_2 - s_1) = (0.2976 \text{ kg/s})(7.2454 - 6.9583) \text{ kJ/kg} \cdot \text{K} = \mathbf{0.0854 \text{ kW/K}}$$

7-154 Steam expands in a turbine from a specified state to another specified state. The rate of entropy generation during this process is to be determined.

Assumptions 1 This is a steady-flow process since there is no change with time. **2** Kinetic and potential energy changes are negligible.

Properties From the steam tables (Tables A-4 through 6)

$$\left. \begin{array}{l} P_1 = 8 \text{ MPa} \\ T_1 = 500^\circ\text{C} \end{array} \right\} \begin{array}{l} h_1 = 3399.5 \text{ kJ/kg} \\ s_1 = 6.7266 \text{ kJ/kg} \cdot \text{K} \end{array}$$

$$\left. \begin{array}{l} P_2 = 40 \text{ kPa} \\ \text{sat. vapor} \end{array} \right\} \begin{array}{l} h_2 = 2636.1 \text{ kJ/kg} \\ s_2 = 7.6691 \text{ kJ/kg} \cdot \text{K} \end{array}$$

Analysis There is only one inlet and one exit, and thus $\dot{m}_1 = \dot{m}_2 = \dot{m}$. We take the turbine as the system, which is a control volume since mass crosses the boundary. The energy balance for this steady-flow system can be expressed in the rate form as

$$\underbrace{\dot{E}_{\text{in}} - \dot{E}_{\text{out}}}_{\text{Rate of net energy transfer by heat, work, and mass}} = \underbrace{\Delta \dot{E}_{\text{system}}}_{\text{Rate of change in internal, kinetic, potential, etc. energies}} \stackrel{\text{no (steady)}}{=} 0$$

$$\dot{E}_{\text{in}} = \dot{E}_{\text{out}}$$

$$\dot{m}h_1 = \dot{Q}_{\text{out}} + \dot{W}_{\text{out}} + \dot{m}h_2$$

$$\dot{Q}_{\text{out}} = \dot{m}(h_1 - h_2) - \dot{W}_{\text{out}}$$

Substituting,

$$\dot{Q}_{\text{out}} = (40,000/3600 \text{ kg/s})(3399.5 - 2636.1) \text{ kJ/kg} - 8200 \text{ kJ/s} = 282.6 \text{ kJ/s}$$

The rate of total entropy generation during this process is determined by applying the entropy balance on an *extended system* that includes the turbine and its immediate surroundings so that the boundary temperature of the extended system is 25°C at all times. It gives

$$\underbrace{\dot{S}_{\text{in}} - \dot{S}_{\text{out}}}_{\text{Rate of net entropy transfer by heat and mass}} + \underbrace{\dot{S}_{\text{gen}}}_{\text{Rate of entropy generation}} = \underbrace{\Delta \dot{S}_{\text{system}}}_{\text{Rate of change of entropy}} \stackrel{\text{no}}{=} 0$$

$$\dot{m}s_1 - \dot{m}s_2 - \frac{\dot{Q}_{\text{out}}}{T_{\text{b,surr}}} + \dot{S}_{\text{gen}} = 0$$

Substituting, the rate of entropy generation during this process is determined to be

$$\dot{S}_{\text{gen}} = \dot{m}(s_2 - s_1) + \frac{\dot{Q}_{\text{out}}}{T_{\text{b,surr}}} = (40,000/3600 \text{ kg/s})(7.6691 - 6.7266) \text{ kJ/kg} \cdot \text{K} + \frac{282.6 \text{ kW}}{298 \text{ K}} = \mathbf{11.4 \text{ kW/K}}$$

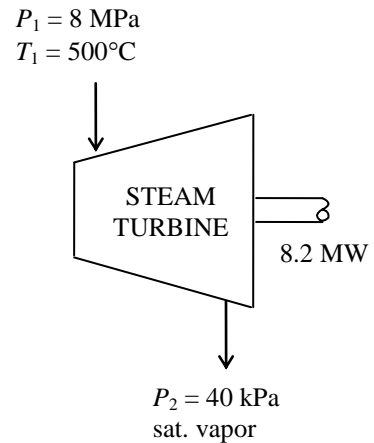

7-155 A hot water stream is mixed with a cold water stream. For a specified mixture temperature, the mass flow rate of cold water stream and the rate of entropy generation are to be determined.

Assumptions 1 Steady operating conditions exist. 2 The mixing chamber is well-insulated so that heat loss to the surroundings is negligible. 3 Changes in the kinetic and potential energies of fluid streams are negligible.

Properties Noting that $T < T_{\text{sat @ 200 kPa}} = 120.21^\circ\text{C}$, the water in all three streams exists as a compressed liquid, which can be approximated as a saturated liquid at the given temperature. Thus from Table A-4,

$$\begin{aligned} P_1 = 200 \text{ kPa} \left\{ \begin{array}{l} h_1 \cong h_{f@70^\circ\text{C}} = 293.07 \text{ kJ/kg} \\ T_1 = 70^\circ\text{C} \left\{ \begin{array}{l} s_1 \cong s_{f@70^\circ\text{C}} = 0.9551 \text{ kJ/kg}\cdot\text{K} \end{array} \right. \end{array} \right. \\ \\ P_2 = 200 \text{ kPa} \left\{ \begin{array}{l} h_2 \cong h_{f@20^\circ\text{C}} = 83.91 \text{ kJ/kg} \\ T_2 = 20^\circ\text{C} \left\{ \begin{array}{l} s_2 \cong s_{f@20^\circ\text{C}} = 0.2965 \text{ kJ/kg}\cdot\text{K} \end{array} \right. \end{array} \right. \\ \\ P_3 = 200 \text{ kPa} \left\{ \begin{array}{l} h_3 \cong h_{f@42^\circ\text{C}} = 175.90 \text{ kJ/kg} \\ T_3 = 42^\circ\text{C} \left\{ \begin{array}{l} s_3 \cong s_{f@42^\circ\text{C}} = 0.5990 \text{ kJ/kg}\cdot\text{K} \end{array} \right. \end{array} \right. \end{aligned}$$

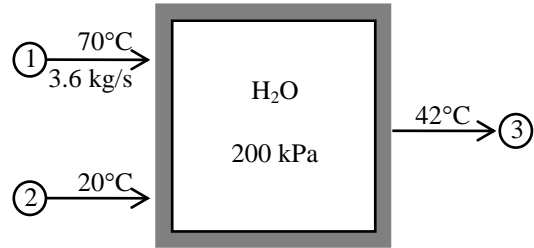

Analysis (a) We take the mixing chamber as the system, which is a control volume. The mass and energy balances for this steady-flow system can be expressed in the rate form as

$$\text{Mass balance: } \dot{m}_{\text{in}} - \dot{m}_{\text{out}} = \Delta \dot{E}_{\text{system}}^{\neq 0 \text{ (steady)}} = 0 \longrightarrow \dot{m}_1 + \dot{m}_2 = \dot{m}_3$$

Energy balance:

$$\underbrace{\dot{E}_{\text{in}} - \dot{E}_{\text{out}}}_{\text{Rate of net energy transfer by heat, work, and mass}} = \underbrace{\Delta \dot{E}_{\text{system}}^{\neq 0 \text{ (steady)}}}_{\text{Rate of change in internal, kinetic, potential, etc. energies}} = 0$$

$$\dot{E}_{\text{in}} = \dot{E}_{\text{out}}$$

$$\dot{m}_1 h_1 + \dot{m}_2 h_2 = \dot{m}_3 h_3 \quad (\text{since } \dot{Q} = \dot{W} = \Delta \text{ke} \cong \Delta \text{pe} \cong 0)$$

Combining the two relations gives

$$\dot{m}_1 h_1 + \dot{m}_2 h_2 = (\dot{m}_1 + \dot{m}_2) h_3$$

Solving for \dot{m}_2 and substituting, the mass flow rate of cold water stream is determined to be

$$\dot{m}_2 = \frac{h_1 - h_3}{h_3 - h_2} \dot{m}_1 = \frac{(293.07 - 175.90) \text{ kJ/kg}}{(175.90 - 83.91) \text{ kJ/kg}} (3.6 \text{ kg/s}) = \mathbf{4.586 \text{ kg/s}}$$

Also,

$$\dot{m}_3 = \dot{m}_1 + \dot{m}_2 = 3.6 + 4.586 = 8.186 \text{ kg/s}$$

(b) Noting that the mixing chamber is adiabatic and thus there is no heat transfer to the surroundings, the entropy balance of the steady-flow system (the mixing chamber) can be expressed as

$$\underbrace{\dot{S}_{\text{in}} - \dot{S}_{\text{out}}}_{\text{Rate of net entropy transfer by heat and mass}} + \underbrace{\dot{S}_{\text{gen}}}_{\text{Rate of entropy generation}} = \underbrace{\Delta \dot{S}_{\text{system}}^{\neq 0}}_{\text{Rate of change of entropy}} = 0$$

$$\dot{m}_1 s_1 + \dot{m}_2 s_2 - \dot{m}_3 s_3 + \dot{S}_{\text{gen}} = 0$$

Substituting, the total rate of entropy generation during this process becomes

$$\begin{aligned} \dot{S}_{\text{gen}} &= \dot{m}_3 s_3 - \dot{m}_2 s_2 - \dot{m}_1 s_1 \\ &= (8.186 \text{ kg/s})(0.5990 \text{ kJ/kg}\cdot\text{K}) - (4.586 \text{ kg/s})(0.2965 \text{ kJ/kg}\cdot\text{K}) - (3.6 \text{ kg/s})(0.9551 \text{ kJ/kg}\cdot\text{K}) \\ &= \mathbf{0.1054 \text{ kW/K}} \end{aligned}$$

7-156 Liquid water is heated in a chamber by mixing it with superheated steam. For a specified mixing temperature, the mass flow rate of the steam and the rate of entropy generation are to be determined.

Assumptions 1 This is a steady-flow process since there is no change with time. **2** Kinetic and potential energy changes are negligible. **3** There are no work interactions.

Properties Noting that $T < T_{\text{sat}} @ 200 \text{ kPa} = 120.21^\circ\text{C}$, the cold water and the exit mixture streams exist as a compressed liquid, which can be approximated as a saturated liquid at the given temperature. From Tables A-4 through A-6,

$$\left. \begin{array}{l} P_1 = 200 \text{ kPa} \\ T_1 = 15^\circ\text{C} \end{array} \right\} \begin{array}{l} h_1 \cong h_{f@15^\circ\text{C}} = 62.98 \text{ kJ/kg} \\ s_1 \cong s_{f@15^\circ\text{C}} = 0.2245 \text{ kJ/kg} \cdot \text{K} \end{array}$$

$$\left. \begin{array}{l} P_2 = 200 \text{ kPa} \\ T_2 = 150^\circ\text{C} \end{array} \right\} \begin{array}{l} h_2 = 2769.1 \text{ kJ/kg} \\ s_2 = 7.2810 \text{ kJ/kg} \cdot \text{K} \end{array}$$

$$\left. \begin{array}{l} P_3 = 200 \text{ kPa} \\ T_3 = 80^\circ\text{C} \end{array} \right\} \begin{array}{l} h_3 \cong h_{f@80^\circ\text{C}} = 335.02 \text{ kJ/kg} \\ s_3 \cong s_{f@80^\circ\text{C}} = 1.0756 \text{ kJ/kg} \cdot \text{K} \end{array}$$

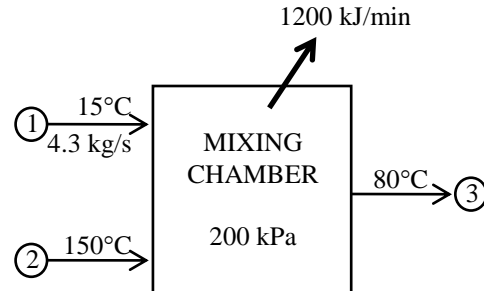

Analysis (a) We take the mixing chamber as the system, which is a control volume. The mass and energy balances for this steady-flow system can be expressed in the rate form as

$$\text{Mass balance: } \dot{m}_{\text{in}} - \dot{m}_{\text{out}} = \Delta \dot{m}_{\text{system}} \stackrel{\neq 0 \text{ (steady)}}{=} 0 \longrightarrow \dot{m}_1 + \dot{m}_2 = \dot{m}_3$$

Energy balance:

$$\underbrace{\dot{E}_{\text{in}} - \dot{E}_{\text{out}}}_{\text{Rate of net energy transfer by heat, work, and mass}} = \underbrace{\Delta \dot{E}_{\text{system}}}_{\text{Rate of change in internal, kinetic, potential, etc. energies}} \stackrel{\neq 0 \text{ (steady)}}{=} 0$$

$$\dot{E}_{\text{in}} = \dot{E}_{\text{out}}$$

$$\dot{m}_1 h_1 + \dot{m}_2 h_2 = \dot{Q}_{\text{out}} + \dot{m}_3 h_3$$

Combining the two relations gives

$$\dot{Q}_{\text{out}} = \dot{m}_1 h_1 + \dot{m}_2 h_2 - (\dot{m}_1 + \dot{m}_2) h_3 = \dot{m}_1 (h_1 - h_3) + \dot{m}_2 (h_2 - h_3)$$

Solving for \dot{m}_2 and substituting, the mass flow rate of the superheated steam is determined to be

$$\dot{m}_2 = \frac{\dot{Q}_{\text{out}} - \dot{m}_1 (h_1 - h_3)}{h_2 - h_3} = \frac{(1200/60 \text{ kJ/s}) - (4.3 \text{ kg/s})(62.98 - 335.02) \text{ kJ/kg}}{(2769.1 - 335.02) \text{ kJ/kg}} = \mathbf{0.4806 \text{ kg/s}}$$

$$\text{Also, } \dot{m}_3 = \dot{m}_1 + \dot{m}_2 = 4.3 + 0.4806 = 4.781 \text{ kg/s}$$

(b) The rate of total entropy generation during this process is determined by applying the entropy balance on an *extended system* that includes the mixing chamber and its immediate surroundings so that the boundary temperature of the extended system is 25°C at all times. It gives

$$\underbrace{\dot{S}_{\text{in}} - \dot{S}_{\text{out}}}_{\text{Rate of net entropy transfer by heat and mass}} + \underbrace{\dot{S}_{\text{gen}}}_{\text{Rate of entropy generation}} = \underbrace{\Delta \dot{S}_{\text{system}}}_{\text{Rate of change of entropy}} \stackrel{\neq 0}{=} 0$$

$$\dot{m}_1 s_1 + \dot{m}_2 s_2 - \dot{m}_3 s_3 - \frac{\dot{Q}_{\text{out}}}{T_{\text{b,surr}}} + \dot{S}_{\text{gen}} = 0$$

Substituting, the rate of entropy generation during this process is determined to be

$$\begin{aligned} \dot{S}_{\text{gen}} &= \dot{m}_3 s_3 - \dot{m}_2 s_2 - \dot{m}_1 s_1 + \frac{\dot{Q}_{\text{out}}}{T_{\text{b,surr}}} \\ &= (4.781 \text{ kg/s})(1.0756 \text{ kJ/kg} \cdot \text{K}) - (0.4806 \text{ kg/s})(7.2810 \text{ kJ/kg} \cdot \text{K}) \\ &\quad - (4.3 \text{ kg/s})(0.2245 \text{ kJ/kg} \cdot \text{K}) + \frac{(1200/60 \text{ kJ/s})}{293 \text{ K}} \\ &= \mathbf{0.746 \text{ kW/K}} \end{aligned}$$

7-157 A rigid tank initially contains saturated liquid water. A valve at the bottom of the tank is opened, and half of mass in liquid form is withdrawn from the tank. The temperature in the tank is maintained constant. The amount of heat transfer and the entropy generation during this process are to be determined.

Assumptions 1 This is an unsteady process since the conditions within the device are changing during the process, but it can be analyzed as a uniform-flow process since the state of fluid leaving the device remains constant. **2** Kinetic and potential energies are negligible. **3** There are no work interactions involved. **4** The direction of heat transfer is to the tank (will be verified).

Properties The properties of water are (Tables A-4 through A-6)

$$T_1 = 120^\circ\text{C} \left\{ \begin{array}{l} \nu_1 = \nu_{f@120^\circ\text{C}} = 0.001060 \text{ m}^3/\text{kg} \\ u_1 = u_{f@120^\circ\text{C}} = 503.60 \text{ kJ/kg} \\ s_1 = s_{f@120^\circ\text{C}} = 1.5279 \text{ kJ/kg} \cdot \text{K} \end{array} \right.$$

$$T_e = 120^\circ\text{C} \left\{ \begin{array}{l} h_e = h_{f@120^\circ\text{C}} = 503.81 \text{ kJ/kg} \\ s_e = s_{f@120^\circ\text{C}} = 1.5279 \text{ kJ/kg} \cdot \text{K} \end{array} \right.$$

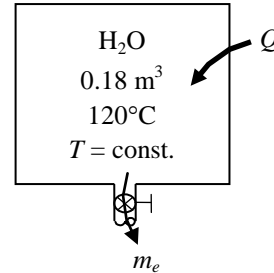

Analysis (a) We take the tank as the system, which is a control volume since mass crosses the boundary. Noting that the microscopic energies of flowing and nonflowing fluids are represented by enthalpy h and internal energy u , respectively, the mass and energy balances for this uniform-flow system can be expressed as

Mass balance:

$$m_{\text{in}} - m_{\text{out}} = \Delta m_{\text{system}} \rightarrow m_e = m_1 - m_2$$

Energy balance:

$$\underbrace{E_{\text{in}} - E_{\text{out}}}_{\text{Net energy transfer by heat, work, and mass}} = \underbrace{\Delta E_{\text{system}}}_{\text{Change in internal, kinetic, potential, etc. energies}}$$

$$Q_{\text{in}} = m_e h_e + m_2 u_2 - m_1 u_1 \quad (\text{since } W \cong \text{ke} \cong \text{pe} \cong 0)$$

The initial and the final masses in the tank are

$$m_1 = \frac{\nu}{\nu_1} = \frac{0.18 \text{ m}^3}{0.001060 \text{ m}^3/\text{kg}} = 169.76 \text{ kg}$$

$$m_2 = \frac{1}{2} m_1 = \frac{1}{2} (169.76 \text{ kg}) = 84.88 \text{ kg} = m_e$$

Now we determine the final internal energy and entropy,

$$\nu_2 = \frac{\nu}{m_2} = \frac{0.18 \text{ m}^3}{84.88 \text{ kg}} = 0.002121 \text{ m}^3/\text{kg}$$

$$x_2 = \frac{\nu_2 - \nu_f}{\nu_{fg}} = \frac{0.002121 - 0.001060}{0.8913 - 0.001060} = 0.001191$$

$$T_2 = 120^\circ\text{C} \left\{ \begin{array}{l} u_2 = u_f + x_2 u_{fg} = 503.60 + (0.001191)(2025.3) = 506.01 \text{ kJ/kg} \\ s_2 = s_f + x_2 s_{fg} = 1.5279 + (0.001191)(5.6013) = 1.5346 \text{ kJ/kg} \cdot \text{K} \end{array} \right.$$

The heat transfer during this process is determined by substituting these values into the energy balance equation,

$$\begin{aligned} Q_{\text{in}} &= m_e h_e + m_2 u_2 - m_1 u_1 \\ &= (84.88 \text{ kg})(503.81 \text{ kJ/kg}) + (84.88 \text{ kg})(506.01 \text{ kJ/kg}) - (169.76 \text{ kg})(503.60 \text{ kJ/kg}) \\ &= \mathbf{222.6 \text{ kJ}} \end{aligned}$$

(b) The total entropy generation is determined by considering a combined system that includes the tank and the heat source. Noting that no heat crosses the boundaries of this combined system and no mass enters, the entropy balance for it can be expressed as

$$\underbrace{S_{\text{in}} - S_{\text{out}}}_{\text{Net entropy transfer by heat and mass}} + \underbrace{S_{\text{gen}}}_{\text{Entropy generation}} = \underbrace{\Delta S_{\text{system}}}_{\text{Change in entropy}} \longrightarrow -m_e s_e + S_{\text{gen}} = \Delta S_{\text{tank}} + \Delta S_{\text{source}}$$

Therefore, the total entropy generated during this process is

$$\begin{aligned} S_{\text{gen}} &= m_e s_e + \Delta S_{\text{tank}} + \Delta S_{\text{source}} = m_e s_e + (m_2 s_2 - m_1 s_1) - \frac{Q_{\text{source,out}}}{T_{\text{source}}} \\ &= (84.88 \text{ kg})(1.5279 \text{ kJ/kg} \cdot \text{K}) + (84.88 \text{ kg})(1.5346 \text{ kJ/kg} \cdot \text{K}) \\ &\quad - (169.76 \text{ kg})(1.5279 \text{ kJ/kg} \cdot \text{K}) - \frac{222.6 \text{ kJ}}{(230 + 273) \text{ K}} \\ &= \mathbf{0.1237 \text{ kJ/K}} \end{aligned}$$

7-158E An unknown mass of iron is dropped into water in an insulated tank while being stirred by a 200-W paddle wheel. Thermal equilibrium is established after 10 min. The mass of the iron block and the entropy generated during this process are to be determined.

Assumptions 1 Both the water and the iron block are incompressible substances with constant specific heats at room temperature. **2** The system is stationary and thus the kinetic and potential energy changes are zero. **3** The system is well-insulated and thus there is no heat transfer.

Properties The specific heats of water and the iron block at room temperature are $c_{p, \text{water}} = 1.00 \text{ Btu/lbm}\cdot^\circ\text{F}$ and $c_{p, \text{iron}} = 0.107 \text{ Btu/lbm}\cdot^\circ\text{F}$ (Table A-3E). The density of water at room temperature is 62.1 lbm/ft^3 .

Analysis (a) We take the entire contents of the tank, water + iron block, as the system. This is a closed system since no mass crosses the system boundary during the process. The energy balance on the system can be expressed as

$$\underbrace{E_{\text{in}} - E_{\text{out}}}_{\substack{\text{Net energy transfer} \\ \text{by heat, work, and mass}}} = \underbrace{\Delta E_{\text{system}}}_{\substack{\text{Change in internal, kinetic,} \\ \text{potential, etc. energies}}}$$

$$W_{\text{pw, in}} = \Delta U$$

or,
$$W_{\text{pw, in}} = \Delta U_{\text{iron}} + \Delta U_{\text{water}}$$

$$W_{\text{pw, in}} = [mc(T_2 - T_1)]_{\text{iron}} + [mc(T_2 - T_1)]_{\text{water}}$$

where

$$m_{\text{water}} = \rho V = (62.1 \text{ lbm/ft}^3)(0.8 \text{ ft}^3) = 49.7 \text{ lbm}$$

$$W_{\text{pw}} = \dot{W}_{\text{pw}} \Delta t = (0.2 \text{ kJ/s})(10 \times 60 \text{ s}) \left(\frac{1 \text{ Btu}}{1.055 \text{ kJ}} \right) = 113.7 \text{ Btu}$$

Using specific heat values for iron and liquid water and substituting,

$$113.7 \text{ Btu} = m_{\text{iron}}(0.107 \text{ Btu/lbm}\cdot^\circ\text{F})(75 - 185)^\circ\text{F} + (49.7 \text{ lbm})(1.00 \text{ Btu/lbm}\cdot^\circ\text{F})(75 - 70)^\circ\text{F}$$

$$m_{\text{iron}} = \mathbf{11.4 \text{ lbm}}$$

(b) Again we take the iron + water in the tank to be the system. Noting that no heat or mass crosses the boundaries of this combined system, the entropy balance for it can be expressed as

$$\underbrace{S_{\text{in}} - S_{\text{out}}}_{\substack{\text{Net entropy transfer} \\ \text{by heat and mass}}} + \underbrace{S_{\text{gen}}}_{\substack{\text{Entropy} \\ \text{generation}}} = \underbrace{\Delta S_{\text{system}}}_{\substack{\text{Change} \\ \text{in entropy}}}$$

$$0 + S_{\text{gen, total}} = \Delta S_{\text{iron}} + \Delta S_{\text{water}}$$

where

$$\Delta S_{\text{iron}} = mc_{\text{avg}} \ln \left(\frac{T_2}{T_1} \right) = (11.4 \text{ lbm})(0.107 \text{ Btu/lbm}\cdot\text{R}) \ln \left(\frac{535 \text{ R}}{645 \text{ R}} \right) = -0.228 \text{ Btu/R}$$

$$\Delta S_{\text{water}} = mc_{\text{avg}} \ln \left(\frac{T_2}{T_1} \right) = (49.6 \text{ lbm})(1.0 \text{ Btu/lbm}\cdot\text{R}) \ln \left(\frac{535 \text{ R}}{530 \text{ R}} \right) = 0.466 \text{ Btu/R}$$

Therefore, the entropy generated during this process is

$$\Delta S_{\text{total}} = S_{\text{gen}} = \Delta S_{\text{iron}} + \Delta S_{\text{water}} = -0.228 + 0.466 = \mathbf{0.238 \text{ Btu/R}}$$

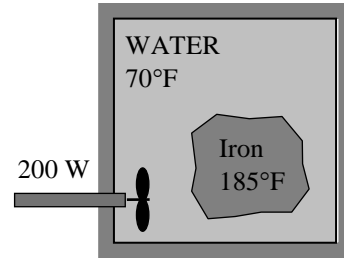

Special Topic: Reducing the Cost of Compressed Air

7-159 The total installed power of compressed air systems in the US is estimated to be about 20 million horsepower. The amount of energy and money that will be saved per year if the energy consumed by compressors is reduced by 5 percent is to be determined.

Assumptions 1 The compressors operate at full load during one-third of the time on average, and are shut down the rest of the time. **2** The average motor efficiency is 85 percent.

Analysis The electrical energy consumed by compressors per year is

$$\begin{aligned}\text{Energy consumed} &= (\text{Power rating})(\text{Load factor})(\text{Annual Operating Hours})/\text{Motor efficiency} \\ &= (20 \times 10^6 \text{ hp})(0.746 \text{ kW/hp})(1/3)(365 \times 24 \text{ hours/year})/0.90 \\ &= 4.839 \times 10^{10} \text{ kWh/year}\end{aligned}$$

Then the energy and cost savings corresponding to a 5% reduction in energy use for compressed air become

$$\begin{aligned}\text{Energy Savings} &= (\text{Energy consumed})(\text{Fraction saved}) \\ &= (4.839 \times 10^{10} \text{ kWh})(0.05) \\ &= \mathbf{2.419 \times 10^9 \text{ kWh/year}} \\ \text{Cost Savings} &= (\text{Energy savings})(\text{Unit cost of energy}) \\ &= (2.419 \times 10^9 \text{ kWh/year})(\$0.11/\text{kWh}) \\ &= \mathbf{\$0.266 \times 10^9 \text{ /year}}\end{aligned}$$

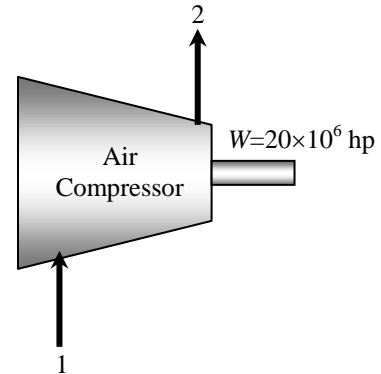

Therefore, reducing the energy usage of compressors by 5% will save \$266 million a year.

7-160 The compressed air requirements of a plant is being met by a 90 hp compressor that compresses air from 101.3 kPa to 1100 kPa. The amount of energy and money saved by reducing the pressure setting of compressed air to 750 kPa is to be determined.

Assumptions **1** Air is an ideal gas with constant specific heats. **2** Kinetic and potential energy changes are negligible. **3** The load factor of the compressor is given to be 0.75. **4** The pressures given are absolute pressure rather than gage pressure.

Properties The specific heat ratio of air is $k = 1.4$ (Table A-2).

Analysis The electrical energy consumed by this compressor per year is

$$\begin{aligned}\text{Energy consumed} &= (\text{Power rating})(\text{Load factor})(\text{Annual Operating Hours})/\text{Motor efficiency} \\ &= (90 \text{ hp})(0.746 \text{ kW/hp})(0.75)(3500 \text{ hours/year})/0.94 \\ &= 187,420 \text{ kWh/year}\end{aligned}$$

The fraction of energy saved as a result of reducing the pressure setting of the compressor is

$$\begin{aligned}\text{Power Reduction Factor} &= 1 - \frac{(P_{2,\text{reduced}} / P_1)^{(k-1)/k} - 1}{(P_2 / P_1)^{(k-1)/k} - 1} \\ &= 1 - \frac{(750/101.3)^{(1.4-1)/1.4} - 1}{(1100/101.3)^{(1.4-1)/1.4} - 1} \\ &= 0.2098\end{aligned}$$

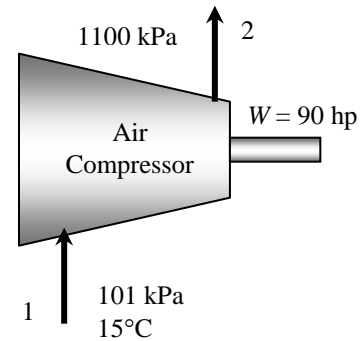

That is, reducing the pressure setting will result in about 11 percent savings from the energy consumed by the compressor and the associated cost. Therefore, the energy and cost savings in this case become

$$\begin{aligned}\text{Energy Savings} &= (\text{Energy consumed})(\text{Power reduction factor}) \\ &= (187,420 \text{ kWh/year})(0.2098) \\ &= \mathbf{39,320 \text{ kWh/year}}\end{aligned}$$

$$\begin{aligned}\text{Cost Savings} &= (\text{Energy savings})(\text{Unit cost of energy}) \\ &= (39,320 \text{ kWh/year})(\$0.105/\text{kWh}) \\ &= \mathbf{\$4128/\text{year}}\end{aligned}$$

Therefore, reducing the pressure setting by 250 kPa will result in annual savings of 39,320 kWh that is worth \$4128 in this case.

Discussion Some applications require very low pressure compressed air. In such cases the need can be met by a blower instead of a compressor. Considerable energy can be saved in this manner, since a blower requires a small fraction of the power needed by a compressor for a specified mass flow rate.

7-161 A 150 hp compressor in an industrial facility is housed inside the production area where the average temperature during operating hours is 25°C. The amounts of energy and money saved as a result of drawing cooler outside air to the compressor instead of using the inside air are to be determined.

Assumptions **1** Air is an ideal gas with constant specific heats. **2** Kinetic and potential energy changes are negligible.

Analysis The electrical energy consumed by this compressor per year is

$$\begin{aligned}\text{Energy consumed} &= (\text{Power rating})(\text{Load factor})(\text{Annual Operating Hours})/\text{Motor efficiency} \\ &= (150 \text{ hp})(0.746 \text{ kW/hp})(0.85)(4500 \text{ hours/year})/0.9 \\ &= 475,384 \text{ kWh/year}\end{aligned}$$

Also,

$$\begin{aligned}\text{Cost of Energy} &= (\text{Energy consumed})(\text{Unit cost of energy}) \\ &= (475,384 \text{ kWh/year})(\$0.07/\text{kWh}) \\ &= \$33,277/\text{year}\end{aligned}$$

The fraction of energy saved as a result of drawing in cooler outside air is

$$\text{Power Reduction Factor} = 1 - \frac{T_{\text{outside}}}{T_{\text{inside}}} = 1 - \frac{10 + 273}{25 + 273} = 0.0503$$

That is, drawing in air which is 15°C cooler will result in 5.03 percent savings from the energy consumed by the compressor and the associated cost. Therefore, the energy and cost savings in this case become

$$\begin{aligned}\text{Energy Savings} &= (\text{Energy consumed})(\text{Power reduction factor}) \\ &= (475,384 \text{ kWh/year})(0.0503) \\ &= \mathbf{23,929 \text{ kWh/year}}\end{aligned}$$

$$\begin{aligned}\text{Cost Savings} &= (\text{Energy savings})(\text{Unit cost of energy}) \\ &= (23,929 \text{ kWh/year})(\$0.12/\text{kWh}) \\ &= \mathbf{\$2871/\text{year}}\end{aligned}$$

Therefore, drawing air in from the outside will result in annual savings of 23,929 kWh, which is worth \$2871 in this case.

Discussion The price of a typical 150 hp compressor is much lower than \$50,000. Therefore, it is interesting to note that the cost of energy a compressor uses a year may be more than the cost of the compressor itself.

The implementation of this measure requires the installation of an ordinary sheet metal or PVC duct from the compressor intake to the outside. The installation cost associated with this measure is relatively low, and the pressure drop in the duct in most cases is negligible. About half of the manufacturing facilities we have visited, especially the newer ones, have the duct from the compressor intake to the outside in place, and they are already taking advantage of the savings associated with this measure.

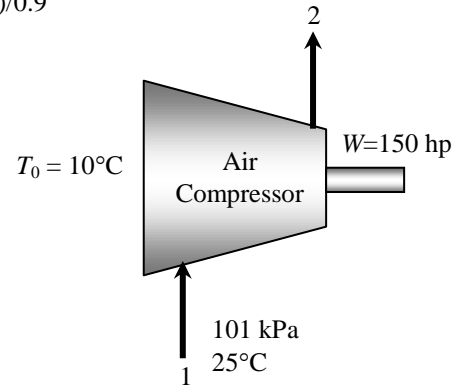

7-162 The compressed air requirements of the facility during 60 percent of the time can be met by a 25 hp reciprocating compressor instead of the existing 100 hp compressor. The amounts of energy and money saved as a result of switching to the 25 hp compressor during 60 percent of the time are to be determined.

Analysis Noting that 1 hp = 0.746 kW, the electrical energy consumed by each compressor per year is determined from

$$\begin{aligned} (\text{Energy consumed})_{\text{Large}} &= (\text{Power})(\text{Hours})[(\text{LFxTF}/\eta_{\text{motor}})_{\text{Unloaded}} + (\text{LFxTF}/\eta_{\text{motor}})_{\text{Loaded}}] \\ &= (100 \text{ hp})(0.746 \text{ kW/hp})(3800 \text{ hours/year})[0.35 \times 0.6/0.82 + 0.90 \times 0.4/0.9] \\ &= 185,990 \text{ kWh/year} \end{aligned}$$

$$\begin{aligned} (\text{Energy consumed})_{\text{Small}} &= (\text{Power})(\text{Hours})[(\text{LFxTF}/\eta_{\text{motor}})_{\text{Unloaded}} + (\text{LFxTF}/\eta_{\text{motor}})_{\text{Loaded}}] \\ &= (25 \text{ hp})(0.746 \text{ kW/hp})(3800 \text{ hours/year})[0.0 \times 0.15 + 0.95 \times 0.85]/0.88 \\ &= 65,031 \text{ kWh/year} \end{aligned}$$

Therefore, the energy and cost savings in this case become

$$\begin{aligned} \text{Energy Savings} &= (\text{Energy consumed})_{\text{Large}} - (\text{Energy consumed})_{\text{Small}} \\ &= 185,990 - 65,031 \text{ kWh/year} \\ &= \mathbf{120,959 \text{ kWh/year}} \end{aligned}$$

$$\begin{aligned} \text{Cost Savings} &= (\text{Energy savings})(\text{Unit cost of energy}) \\ &= (120,959 \text{ kWh/year})(\$0.115/\text{kWh}) \\ &= \mathbf{\$13,910/\text{year}} \end{aligned}$$

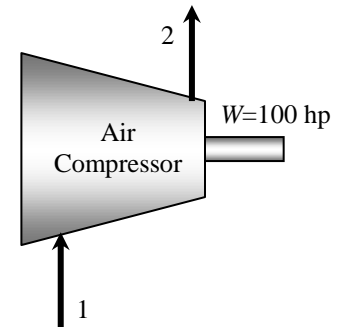

Discussion Note that utilizing a small compressor during the times of reduced compressed air requirements and shutting down the large compressor will result in annual savings of 120,959 kWh, which is worth \$13,910 in this case.

7-163 A facility stops production for one hour every day, including weekends, for lunch break, but the 90 hp compressor is kept operating. If the compressor consumes 35 percent of the rated power when idling, the amounts of energy and money saved per year as a result of turning the compressor off during lunch break are to be determined.

Analysis It seems like the compressor in this facility is kept on unnecessarily for one hour a day and thus 365 hours a year, and the idle factor is 0.35. Then the energy and cost savings associated with turning the compressor off during lunch break are determined to be

$$\begin{aligned} \text{Energy Savings} &= (\text{Power Rating})(\text{Turned Off Hours})(\text{Idle Factor})/\eta_{\text{motor}} \\ &= (90 \text{ hp})(0.7457 \text{ kW/hp})(365 \text{ hours/year})(0.35)/0.84 \\ &= \mathbf{10,207 \text{ kWh/year}} \end{aligned}$$

$$\begin{aligned} \text{Cost Savings} &= (\text{Energy savings})(\text{Unit cost of energy}) \\ &= (10,207 \text{ kWh/year})(\$0.11/\text{kWh}) \\ &= \mathbf{\$1123/\text{year}} \end{aligned}$$

Discussion Note that the simple practice of turning the compressor off during lunch break will save this facility \$1123 a year in energy costs. There are also side benefits such as extending the life of the motor and the compressor, and reducing the maintenance costs.

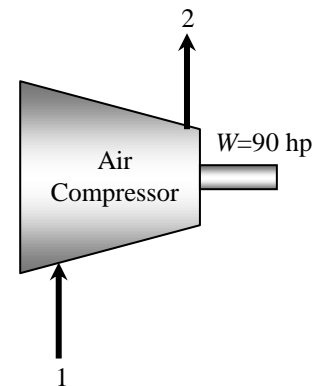

7-164 It is determined that 25 percent of the energy input to the compressor is removed from the compressed air as heat in the aftercooler with a refrigeration unit whose COP is 2.5. The amounts of the energy and money saved per year as a result of cooling the compressed air before it enters the refrigerated dryer are to be determined.

Assumptions The compressor operates at full load when operating.

Analysis Noting that 25 percent of the energy input to the compressor is removed by the aftercooler, the rate of heat removal from the compressed air in the aftercooler under full load conditions is

$$\begin{aligned}\dot{Q}_{\text{aftercooling}} &= (\text{Rated Power of Compressor})(\text{Load Factor})(\text{Aftercooling Fraction}) \\ &= (150 \text{ hp})(0.746 \text{ kW/hp})(1.0)(0.25) = 27.96 \text{ kW}\end{aligned}$$

The compressor is said to operate at full load for 2100 hours a year, and the COP of the refrigeration unit is 2.5. Then the energy and cost savings associated with this measure become

$$\begin{aligned}\text{Energy Savings} &= (\dot{Q}_{\text{aftercooling}})(\text{Annual Operating Hours})/\text{COP} \\ &= (27.96 \text{ kW})(2100 \text{ hours/year})/2.5 \\ &= \mathbf{23,490 \text{ kWh/year}}\end{aligned}$$

$$\begin{aligned}\text{Cost Savings} &= (\text{Energy savings})(\text{Unit cost of energy saved}) \\ &= (23,490 \text{ kWh/year})(\$0.12/\text{kWh}) \\ &= \mathbf{\$2819/\text{year}}\end{aligned}$$

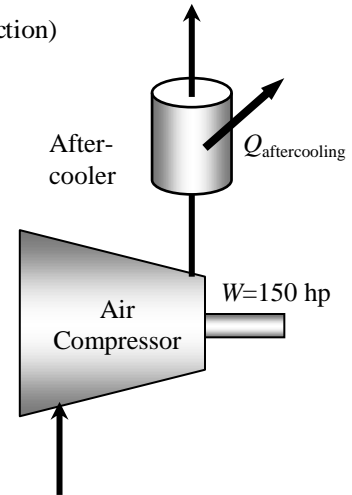

Discussion Note that the aftercooler will save this facility 23,490 kWh of electrical energy worth \$2819 per year. The actual savings will be less than indicated above since we have not considered the power consumed by the fans and/or pumps of the aftercooler. However, if the heat removed by the aftercooler is utilized for some useful purpose such as space heating or process heating, then the actual savings will be much more.

7-165 The motor of a 150 hp compressor is burned out and is to be replaced by either a 93% efficient standard motor or a 96.2% efficient high efficiency motor. The amount of energy and money the facility will save by purchasing the high-efficiency motor instead of standard motor are to be determined. It is also to be determined if the savings from the high efficiency motor justify the price differential.

Assumptions **1** The compressor operates at full load when operating. **2** The life of the motors is 10 years. **3** There are no rebates involved. **4** The price of electricity remains constant.

Analysis The energy and cost savings associated with the installation of the high efficiency motor in this case are determined to be

$$\begin{aligned}\text{Energy Savings} &= (\text{Power Rating})(\text{Operating Hours})(\text{Load Factor})(1/\eta_{\text{standard}} - 1/\eta_{\text{efficient}}) \\ &= (150 \text{ hp})(0.7457 \text{ kW/hp})(4,368 \text{ hours/year})(1.0)(1/0.930 - 1/0.962) \\ &= \mathbf{17,476 \text{ kWh/year}}\end{aligned}$$

$$\begin{aligned}\text{Cost Savings} &= (\text{Energy savings})(\text{Unit cost of energy}) \\ &= (17,476 \text{ kWh/year})(\$0.125/\text{kWh}) \\ &= \mathbf{\$2184/\text{year}}\end{aligned}$$

The additional cost of the energy efficient motor is

$$\text{Cost Differential} = \$10,942 - \$9,031 = \$1,911$$

Discussion The money saved by the high efficiency motor will pay for this cost difference in $\$1,911/\$2184 = 0.875$ year, and will continue saving the facility money for the rest of the 10 years of its lifetime. Therefore, the use of the high efficiency motor is recommended in this case even in the absence of any incentives from the local utility company.

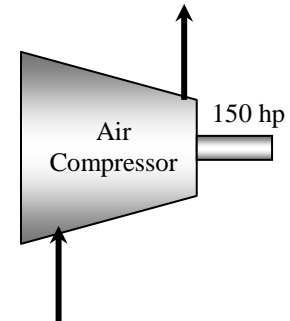

7-166 The compressor of a facility is being cooled by air in a heat-exchanger. This air is to be used to heat the facility in winter. The amount of money that will be saved by diverting the compressor waste heat into the facility during the heating season is to be determined.

Assumptions The compressor operates at full load when operating.

Analysis Assuming $c_p = 1.0 \text{ kJ/kg}\cdot^\circ\text{C}$ and operation at sea level and taking the density of air to be 1.2 kg/m^3 , the mass flow rate of air through the liquid-to-air heat exchanger is determined to be

$$\begin{aligned}\text{Mass flow rate of air} &= (\text{Density of air})(\text{Average velocity})(\text{Flow area}) \\ &= (1.2 \text{ kg/m}^3)(3 \text{ m/s})(1.0 \text{ m}^2) \\ &= 3.6 \text{ kg/s} = 12,960 \text{ kg/h}\end{aligned}$$

Noting that the temperature rise of air is 32°C , the rate at which heat can be recovered (or the rate at which heat is transferred to air) is

$$\begin{aligned}\text{Rate of Heat Recovery} &= (\text{Mass flow rate of air})(\text{Specific heat of air})(\text{Temperature rise}) \\ &= (12,960 \text{ kg/h})(1.0 \text{ kJ/kg}\cdot^\circ\text{C})(32^\circ\text{C}) \\ &= 414,720 \text{ kJ/h}\end{aligned}$$

The number of operating hours of this compressor during the heating season is

$$\begin{aligned}\text{Operating hours} &= (20 \text{ hours/day})(5 \text{ days/week})(26 \text{ weeks/year}) \\ &= 2600 \text{ hours/year}\end{aligned}$$

Then the annual energy and cost savings become

$$\begin{aligned}\text{Energy Savings} &= (\text{Rate of Heat Recovery})(\text{Annual Operating Hours})/\text{Efficiency} \\ &= (414,720 \text{ kJ/h})(2600 \text{ hours/year})/0.85 \\ &= 1,268,555,000 \text{ kJ/year} \\ &= 12,024 \text{ therms/year}\end{aligned}$$

$$\begin{aligned}\text{Cost Savings} &= (\text{Energy savings})(\text{Unit cost of energy saved}) \\ &= (12,024 \text{ therms/year})(\$1.25/\text{therm}) \\ &= \mathbf{\$15,030/\text{year}}\end{aligned}$$

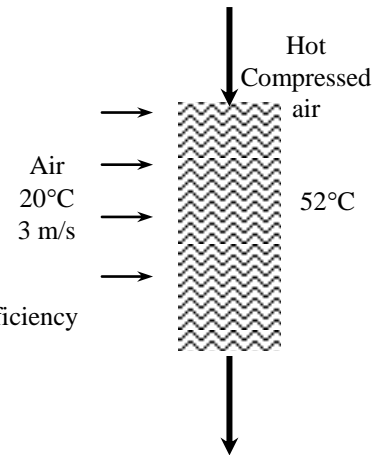

Therefore, utilizing the waste heat from the compressor will save \$15,030 per year from the heating costs.

Discussion The implementation of this measure requires the installation of an ordinary sheet metal duct from the outlet of the heat exchanger into the building. The installation cost associated with this measure is relatively low. A few of the manufacturing facilities we have visited already have this conservation system in place. A damper is used to direct the air into the building in winter and to the ambient in summer.

Combined compressor/heat-recovery systems are available in the market for both air-cooled (greater than 50 hp) and water cooled (greater than 125 hp) systems.

7-167 The compressed air lines in a facility are maintained at a gage pressure of 700 kPa at a location where the atmospheric pressure is 85.6 kPa. There is a 3-mm diameter hole on the compressed air line. The energy and money saved per year by sealing the hole on the compressed air line.

Assumptions 1 Air is an ideal gas with constant specific heats. **2** Kinetic and potential energy changes are negligible.

Properties The gas constant of air is $R = 0.287$ kJ/kg.K. The specific heat ratio of air is $k = 1.4$ (Table A-2).

Analysis Disregarding any pressure losses and noting that the absolute pressure is the sum of the gage pressure and the atmospheric pressure, the work needed to compress a unit mass of air at 15°C from the atmospheric pressure of 85.6 kPa to $700+85.6 = 785.6$ kPa is determined to be

$$\begin{aligned} w_{\text{comp, in}} &= \frac{kRT_1}{\eta_{\text{comp}}(k-1)} \left[\left(\frac{P_2}{P_1} \right)^{(k-1)/k} - 1 \right] \\ &= \frac{(1.4)(0.287 \text{ kJ/kg.K})(288 \text{ K})}{(0.8)(1.4-1)} \left[\left(\frac{785.6 \text{ kPa}}{85.6 \text{ kPa}} \right)^{(1.4-1)/1.4} - 1 \right] \\ &= 319.6 \text{ kJ/kg} \end{aligned}$$

The cross-sectional area of the 5-mm diameter hole is

$$A = \pi D^2 / 4 = \pi (3 \times 10^{-3} \text{ m})^2 / 4 = 7.069 \times 10^{-6} \text{ m}^2$$

Noting that the line conditions are $T_0 = 298$ K and $P_0 = 785.6$ kPa, the mass flow rate of the air leaking through the hole is determined to be

$$\begin{aligned} \dot{m}_{\text{air}} &= C_{\text{loss}} \left(\frac{2}{k+1} \right)^{1/(k-1)} \frac{P_0}{RT_0} A \sqrt{kR \left(\frac{2}{k+1} \right) T_0} \\ &= (0.65) \left(\frac{2}{1.4+1} \right)^{1/(1.4-1)} \frac{785.6 \text{ kPa}}{(0.287 \text{ kPa.m}^3/\text{kg.K})(298 \text{ K})} (7.069 \times 10^{-6} \text{ m}^2) \\ &\quad \times \sqrt{(1.4)(0.287 \text{ kJ/kg.K}) \left(\frac{1000 \text{ m}^2/\text{s}^2}{1 \text{ kJ/kg}} \right) \left(\frac{2}{1.4+1} \right) (298 \text{ K})} \\ &= 0.008451 \text{ kg/s} \end{aligned}$$

Then the power wasted by the leaking compressed air becomes

$$\text{Power wasted} = \dot{m}_{\text{air}} w_{\text{comp, in}} = (0.008451 \text{ kg/s})(319.6 \text{ kJ/kg}) = 2.701 \text{ kW}$$

Noting that the compressor operates 4200 hours a year and the motor efficiency is 0.93, the annual energy and cost savings resulting from repairing this leak are determined to be

$$\begin{aligned} \text{Energy Savings} &= (\text{Power wasted})(\text{Annual operating hours})/\text{Motor efficiency} \\ &= (2.701 \text{ kW})(4200 \text{ hours/year})/0.93 \\ &= \mathbf{12,200 \text{ kWh/year}} \end{aligned}$$

$$\begin{aligned} \text{Cost Savings} &= (\text{Energy savings})(\text{Unit cost of energy}) \\ &= (12,200 \text{ kWh/year})(\$0.12/\text{kWh}) \\ &= \mathbf{\$1464/\text{year}} \end{aligned}$$

Therefore, the facility will save 12,200 kWh of electricity that is worth \$1464 a year when this air leak is sealed.

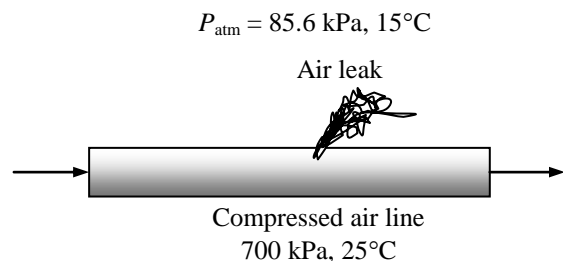

7-168 The total energy used to compress air in the US is estimated to be 0.5×10^{15} kJ per year. About 20% of the compressed air is estimated to be lost by air leaks. The amount and cost of electricity wasted per year due to air leaks is to be determined.

Assumptions About 20% of the compressed air is lost by air leaks.

Analysis The electrical energy and money wasted by air leaks are

$$\begin{aligned} \text{Energy wasted} &= (\text{Energy consumed})(\text{Fraction wasted}) \\ &= (0.5 \times 10^{15} \text{ kJ})(1 \text{ kWh}/3600 \text{ kJ})(0.20) \\ &= \mathbf{27.78 \times 10^9 \text{ kWh/year}} \end{aligned}$$

$$\begin{aligned} \text{Money wasted} &= (\text{Energy wasted})(\text{Unit cost of energy}) \\ &= (27.78 \times 10^9 \text{ kWh/year})(\$0.13/\text{kWh}) \\ &= \mathbf{\$3.611 \times 10^9 \text{ /year}} \end{aligned}$$

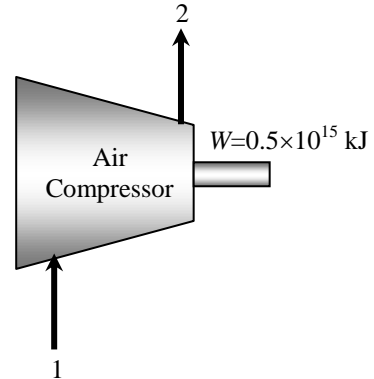

Therefore, air leaks are costing almost \$3.6 billion a year in electricity costs. The environment also suffers from this because of the pollution associated with the generation of this much electricity.

Review Problems

7-169E The source and sink temperatures and the thermal efficiency of a heat engine are given. The entropy change of the two reservoirs is to be calculated and it is to be determined if this engine satisfies the increase of entropy principle.

Assumptions The heat engine operates steadily.

Analysis According to the first law and the definition of the thermal efficiency,

$$Q_L = (1 - \eta)Q_H = (1 - 0.35)(1 \text{ Btu}) = 0.65 \text{ Btu}$$

when the thermal efficiency is 35%. The entropy change of everything involved in this process is then

$$\begin{aligned} \Delta S_{\text{total}} &= \Delta S_H + \Delta S_L \\ &= \frac{Q_H}{T_H} + \frac{Q_L}{T_L} = \frac{-1 \text{ Btu}}{1100 \text{ R}} + \frac{0.65 \text{ Btu}}{550 \text{ R}} = \mathbf{0.000273 \text{ Btu/R}} \end{aligned}$$

Since the entropy of everything has increased, this engine is possible. When the thermal efficiency of the engine is 60%,

$$Q_L = (1 - \eta)Q_H = (1 - 0.6)(1 \text{ Btu}) = 0.4 \text{ Btu}$$

The total entropy change is then

$$\begin{aligned} \Delta S_{\text{total}} &= \Delta S_H + \Delta S_L \\ &= \frac{Q_H}{T_H} + \frac{Q_L}{T_L} = \frac{-1 \text{ Btu}}{1100 \text{ R}} + \frac{0.4 \text{ Btu}}{550 \text{ R}} = \mathbf{-0.000182 \text{ Btu/R}} \end{aligned}$$

which is a decrease in the entropy of everything involved with this engine. Therefore, this engine is now impossible.

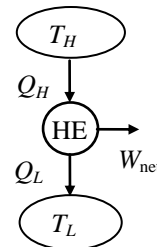

7-170 The source and sink temperatures and the COP of a refrigerator are given. The total entropy change of the two reservoirs is to be calculated and it is to be determined if this refrigerator satisfies the second law.

Assumptions The refrigerator operates steadily.

Analysis Combining the first law and the definition of the coefficient of performance produces

$$Q_H = Q_L \left(1 + \frac{1}{\text{COP}_R} \right) = (1 \text{ kJ}) \left(1 + \frac{1}{4} \right) = 1.25 \text{ kJ}$$

when $\text{COP} = 4$. The entropy change of everything is then

$$\begin{aligned} \Delta S_{\text{total}} &= \Delta S_H + \Delta S_L \\ &= \frac{Q_H}{T_H} + \frac{Q_L}{T_L} = \frac{1.25 \text{ kJ}}{303 \text{ K}} + \frac{-1 \text{ kJ}}{253 \text{ K}} = \mathbf{0.000173 \text{ kJ/K}} \end{aligned}$$

Since the entropy increases, a refrigerator with $\text{COP} = 4$ is possible. When the coefficient of performance is increased to 6,

$$Q_H = Q_L \left(1 + \frac{1}{\text{COP}_R} \right) = (1 \text{ kJ}) \left(1 + \frac{1}{6} \right) = 1.167 \text{ kJ}$$

and the net entropy change is

$$\begin{aligned} \Delta S_{\text{total}} &= \Delta S_H + \Delta S_L \\ &= \frac{Q_H}{T_H} + \frac{Q_L}{T_L} = \frac{1.167 \text{ kJ}}{303 \text{ K}} + \frac{-1 \text{ kJ}}{253 \text{ K}} = \mathbf{-0.000101 \text{ kJ/K}} \end{aligned}$$

and the refrigerator can no longer be possible.

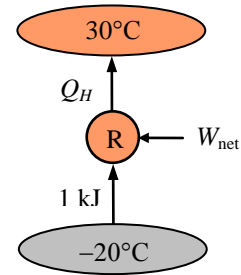

7-171 Air is first compressed adiabatically and then expanded adiabatically to the initial pressure. It is to be determined if the air can be cooled by this process.

Analysis From the entropy change relation of an ideal gas,

$$\Delta s_{\text{air}} = c_p \ln \frac{T_2}{T_1} - R \ln \frac{P_2}{P_1}$$

Since the initial and final pressures are the same, the equation reduces to

$$\Delta s_{\text{air}} = c_p \ln \frac{T_2}{T_1}$$

As there are no heat transfer, the total entropy change (i.e., entropy generation) for this process is equal to the entropy change of air. Therefore, we must have

$$\Delta s_{\text{air}} = c_p \ln \frac{T_2}{T_1} \geq 0$$

The only way this result can be satisfied is if

$$T_2 \geq T_1$$

It is therefore impossible to create a cooling effect ($T_2 < T_1$) in the manner proposed.

7-172E Air is compressed reversibly and isothermally in a piston-cylinder device. The amount of heat transfer is to be determined.

Assumptions 1 Air is an ideal gas since it is at a high temperature and low pressure relative to its critical point values. **2** The kinetic and potential energy changes are negligible, $\Delta ke \cong \Delta pe \cong 0$. **3** Constant specific heats at room temperature can be used for nitrogen.

Properties For air, $R = 0.3704 \text{ psia}\cdot\text{ft}^3/\text{lbm}\cdot\text{R}$ (Table A-1E).

Analysis We take the air as the system. This is a *closed system* since no mass crosses the boundaries of the system. The energy balance for this system can be expressed as

$$\underbrace{E_{\text{in}} - E_{\text{out}}}_{\substack{\text{Net energy transfer} \\ \text{by heat, work, and mass}}} = \underbrace{\Delta E_{\text{system}}}_{\substack{\text{Change in internal, kinetic,} \\ \text{potential, etc. energies}}}$$

$$W_{\text{in}} - Q_{\text{out}} = \Delta U = mc_v(T_2 - T_1) = 0 \quad \text{since } T_2 = T_1$$

$$W_{\text{in}} = Q_{\text{out}}$$

The work done is determined from the boundary work relation for an isothermal process:

$$w_{\text{out}} = \int_1^2 P d\nu = RT \int_1^2 \frac{d\nu}{\nu} = RT \ln \frac{\nu_2}{\nu_1} = RT \ln \frac{P_1}{P_2}$$

$$= (0.3704 \text{ psia}\cdot\text{ft}^3/\text{lbm}\cdot\text{R})(530 \text{ R}) \ln \frac{10 \text{ psia}}{100 \text{ psia}} \left(\frac{1 \text{ Btu}}{5.404 \text{ psia}\cdot\text{ft}^3} \right)$$

$$= -83.6 \text{ Btu/lbm}$$

Then,

$$Q_{\text{out}} = W_{\text{in}} = mw_{\text{in}} = (1 \text{ lbm})(83.6 \text{ Btu/lbm}) = \mathbf{83.6 \text{ Btu}}$$

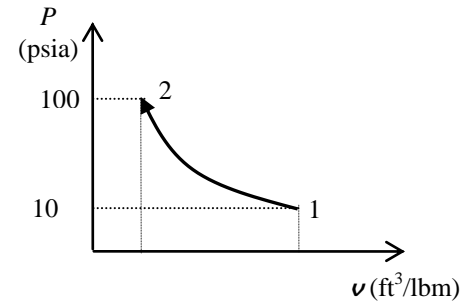

7-173 Water vapor condensed in a piston-cylinder device in an isobaric and reversible process. It is to be determined if the process described is possible.

Analysis We take the water as the system. This is a *closed system* since no mass crosses the boundaries of the system. The energy balance for this system can be expressed as

$$\underbrace{E_{\text{in}} - E_{\text{out}}}_{\text{Net energy transfer by heat, work, and mass}} = \underbrace{\Delta E_{\text{system}}}_{\text{Change in internal, kinetic, potential, etc. energies}}$$

$$-Q_{\text{out}} - W_{\text{b,out}} = \Delta U = m(u_2 - u_1)$$

$$-Q_{\text{out}} = W_{\text{b,out}} + m(u_2 - u_1)$$

$$-Q_{\text{out}} = m(h_2 - h_1)$$

$$Q_{\text{out}} = m(h_1 - h_2)$$

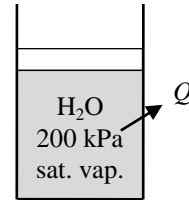

since $\Delta U + W_b = \Delta H$ during a constant pressure quasi-equilibrium process.

The initial and final state properties are (Table A-5)

$$\left. \begin{array}{l} P_1 = 200 \text{ kPa} \\ x_1 = 1 \end{array} \right\} \begin{array}{l} h_1 = 2706.3 \text{ kJ/kg} \\ s_1 = 7.1270 \text{ kJ/kg} \cdot \text{K} \end{array}$$

$$\left. \begin{array}{l} P_2 = 200 \text{ kPa} \\ x_2 = 0 \end{array} \right\} \begin{array}{l} h_2 = 504.71 \text{ kJ/kg} \\ s_2 = 1.5302 \text{ kJ/kg} \cdot \text{K} \end{array}$$

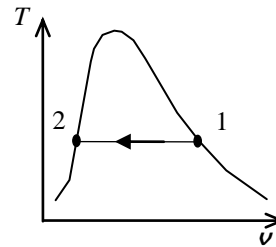

Substituting,

$$q_{\text{out}} = h_1 - h_2 = 2706.3 - 504.71 = 2202 \text{ kJ/kg}$$

The entropy change of the energy reservoir as it undergoes a reversible, isothermal process is

$$\Delta s_{\text{surr}} = \frac{q_{\text{out}}}{T_{\text{res}}} = \frac{2202 \text{ kJ/kg}}{(90 + 273) \text{ K}} = 6.065 \text{ kJ/kg} \cdot \text{K}$$

where the sign of heat transfer is taken positive as the reservoir receives heat. The entropy change of water during the process is

$$\Delta s_w = s_2 - s_1 = 1.5302 - 7.1270 = -5.597 \text{ kJ/kg} \cdot \text{K}$$

The total entropy change is then,

$$\Delta s_{\text{total}} = \Delta s_w + \Delta s_{\text{surr}} = -5.597 + 6.065 = \mathbf{0.468 \text{ kJ/kg} \cdot \text{K}}$$

Since the total entropy change (i.e., entropy generation) is positive, this process is possible.

7-174E A solid block is heated with saturated water vapor. The final temperature of the block and water, and the entropy changes of the block, water, and the entire system are to be determined.

Assumptions 1 The system is stationary and thus the kinetic and potential energy changes are zero. **2** There are no work interactions involved. **3** There is no heat transfer between the system and the surroundings.

Analysis (a) As the block is heated, some of the water vapor will be condensed. We will assume (will be checked later) that the water is a mixture of liquid and vapor at the end of the process. Based upon this assumption, the final temperature of the water and solid block is **227.9°F** (The saturation temperature at 20 psia). The heat picked up by the block is

$$Q_{\text{block}} = mc(T_2 - T_1) = (100 \text{ lbm})(0.5 \text{ Btu/lbm} \cdot \text{R})(227.9 - 80)\text{R} = 7396 \text{ Btu}$$

The water properties at the initial state are

$$\left. \begin{array}{l} P_1 = 20 \text{ psia} \\ x_1 = 1 \end{array} \right\} \begin{array}{l} T_1 = 227.9^\circ\text{F} \\ h_1 = 1156.2 \text{ Btu/lbm} \\ s_1 = 1.7319 \text{ Btu/lbm} \cdot \text{R} \end{array} \quad (\text{Table A-5E})$$

The heat released by the water is equal to the heat picked up by the block. Also noting that the pressure of water remains constant, the enthalpy of water at the end of the heat exchange process is determined from

$$h_2 = h_1 - \frac{Q_{\text{water}}}{m_w} = 1156.2 \text{ Btu/lbm} - \frac{7396 \text{ Btu}}{10 \text{ lbm}} = 416.61 \text{ Btu/lbm}$$

The state of water at the final state is saturated mixture. Thus, our initial assumption was correct. The properties of water at the final state are

$$\left. \begin{array}{l} P_2 = 20 \text{ psia} \\ h_2 = 416.61 \text{ Btu/lbm} \end{array} \right\} \begin{array}{l} x_2 = \frac{h_2 - h_f}{h_{fg}} = \frac{416.61 - 196.27}{959.93} = 0.2295 \\ s_2 = s_f + x_2 s_{fg} = 0.33582 + (0.2295)(1.3961) = 0.65628 \text{ Btu/lbm} \cdot \text{R} \end{array}$$

The entropy change of the water is then

$$\Delta S_{\text{water}} = m_w(s_2 - s_1) = (10 \text{ lbm})(0.65628 - 1.7319)\text{Btu/lbm} = -10.76 \text{ Btu/R}$$

(b) The entropy change of the block is

$$\Delta S_{\text{block}} = mc \ln \frac{T_2}{T_1} = (100 \text{ lbm})(0.5 \text{ Btu/lbm} \cdot \text{R}) \ln \frac{(227.9 + 460)\text{R}}{(80 + 460)\text{R}} = 12.11 \text{ Btu/R}$$

(c) The total entropy change is

$$\Delta S_{\text{total}} = S_{\text{gen}} = \Delta S_{\text{water}} + \Delta S_{\text{block}} = -10.76 + 12.11 = 1.35 \text{ Btu/R}$$

The positive result for the total entropy change (i.e., entropy generation) indicates that this process is possible.

7-175 A horizontal cylinder is separated into two compartments by a piston, one side containing nitrogen and the other side containing helium. Heat is added to the nitrogen side. The final temperature of the helium, the final volume of the nitrogen, the heat transferred to the nitrogen, and the entropy generation during this process are to be determined.

Assumptions 1 Kinetic and potential energy changes are negligible. 2 Nitrogen and helium are ideal gases with constant specific heats at room temperature. 3 The piston is adiabatic and frictionless.

Properties The properties of nitrogen at room temperature are $R = 0.2968 \text{ kPa}\cdot\text{m}^3/\text{kg}\cdot\text{K}$, $c_p = 1.039 \text{ kJ/kg}\cdot\text{K}$, $c_v = 0.743 \text{ kJ/kg}\cdot\text{K}$, $k = 1.4$. The properties for helium are $R = 2.0769 \text{ kPa}\cdot\text{m}^3/\text{kg}\cdot\text{K}$, $c_p = 5.1926 \text{ kJ/kg}\cdot\text{K}$, $c_v = 3.1156 \text{ kJ/kg}\cdot\text{K}$, $k = 1.667$ (Table A-2).

Analysis (a) Helium undergoes an isentropic compression process, and thus the final helium temperature is determined from

$$T_{\text{He},2} = T_1 \left(\frac{P_2}{P_1} \right)^{(k-1)/k} = (20 + 273) \text{K} \left(\frac{120 \text{ kPa}}{95 \text{ kPa}} \right)^{(1.667-1)/1.667} = \mathbf{321.7 \text{ K}}$$

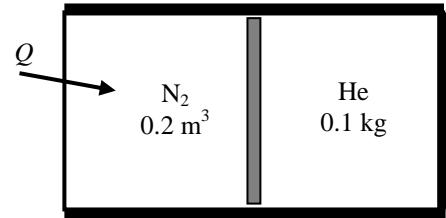

(b) The initial and final volumes of the helium are

$$V_{\text{He},1} = \frac{mRT_1}{P_1} = \frac{(0.1 \text{ kg})(2.0769 \text{ kPa}\cdot\text{m}^3/\text{kg}\cdot\text{K})(20 + 273 \text{ K})}{95 \text{ kPa}} = 0.6406 \text{ m}^3$$

$$V_{\text{He},2} = \frac{mRT_2}{P_2} = \frac{(0.1 \text{ kg})(2.0769 \text{ kPa}\cdot\text{m}^3/\text{kg}\cdot\text{K})(321.7 \text{ K})}{120 \text{ kPa}} = 0.5568 \text{ m}^3$$

Then, the final volume of nitrogen becomes

$$V_{\text{N}_2,2} = V_{\text{N}_2,1} + V_{\text{He},1} - V_{\text{He},2} = 0.2 + 0.6406 - 0.5568 = \mathbf{0.2838 \text{ m}^3}$$

(c) The mass and final temperature of nitrogen are

$$m_{\text{N}_2} = \frac{P_1 V_1}{RT_1} = \frac{(95 \text{ kPa})(0.2 \text{ m}^3)}{(0.2968 \text{ kPa}\cdot\text{m}^3/\text{kg}\cdot\text{K})(20 + 273 \text{ K})} = 0.2185 \text{ kg}$$

$$T_{\text{N}_2,2} = \frac{P_2 V_2}{mR} = \frac{(120 \text{ kPa})(0.2838 \text{ m}^3)}{(0.2185 \text{ kg})(0.2968 \text{ kPa}\cdot\text{m}^3/\text{kg}\cdot\text{K})} = 525.1 \text{ K}$$

The heat transferred to the nitrogen is determined from an energy balance

$$Q_{\text{in}} = \Delta U_{\text{N}_2} + \Delta U_{\text{He}}$$

$$= [mc_v(T_2 - T_1)]_{\text{N}_2} + [mc_v(T_2 - T_1)]_{\text{He}}$$

$$= (0.2185 \text{ kg})(0.743 \text{ kJ/kg}\cdot\text{K})(525.1 - 293) + (0.1 \text{ kg})(3.1156 \text{ kJ/kg}\cdot\text{K})(321.7 - 293)$$

$$= \mathbf{46.6 \text{ kJ}}$$

(d) Noting that helium undergoes an isentropic process, the entropy generation is determined to be

$$S_{\text{gen}} = \Delta S_{\text{N}_2} + \Delta S_{\text{surr}} = m_{\text{N}_2} \left(c_p \ln \frac{T_2}{T_1} - R \ln \frac{P_2}{P_1} \right) + \frac{-Q_{\text{in}}}{T_R}$$

$$= (0.2185 \text{ kg}) \left[(1.039 \text{ kJ/kg}\cdot\text{K}) \ln \frac{525.1 \text{ K}}{293 \text{ K}} - (0.2968 \text{ kJ/kg}\cdot\text{K}) \ln \frac{120 \text{ kPa}}{95 \text{ kPa}} \right] + \frac{-46.6 \text{ kJ}}{(500 + 273) \text{ K}}$$

$$= \mathbf{0.057 \text{ kJ/K}}$$

7-176 A piston-cylinder device contains air that undergoes a reversible thermodynamic cycle composed of three processes. The work and heat transfer for each process are to be determined.

Assumptions 1 All processes are reversible. 2 Kinetic and potential energy changes are negligible. 3 Air is an ideal gas with variable specific heats.

Properties The gas constant of air is $R = 0.287 \text{ kPa}\cdot\text{m}^3/\text{kg}\cdot\text{K}$ (Table A-1).

Analysis Using variable specific heats, the properties can be determined using the air table as follows

$$\begin{aligned} u_1 = u_2 &= 214.07 \text{ kJ/kg} \\ T_1 = T_2 = 300 \text{ K} &\longrightarrow s_1^0 = s_2^0 = 1.70203 \text{ kJ/kg}\cdot\text{K} \\ P_{r1} = P_{r2} &= 1.3860 \\ P_{r3} = \frac{P_3}{P_2} P_{r2} = \frac{400 \text{ kPa}}{150 \text{ kPa}} (1.3860) &= 3.696 \longrightarrow u_3 = 283.71 \text{ kJ/kg} \\ T_3 &= 396.6 \text{ K} \end{aligned}$$

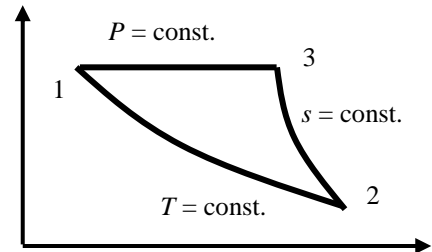

The mass of the air and the volumes at the various states are

$$\begin{aligned} m &= \frac{P_1 V_1}{RT_1} = \frac{(400 \text{ kPa})(0.3 \text{ m}^3)}{(0.287 \text{ kPa}\cdot\text{m}^3/\text{kg}\cdot\text{K})(300 \text{ K})} = 1.394 \text{ kg} \\ v_2 &= \frac{mRT_2}{P_2} = \frac{(1.394 \text{ kg})(0.287 \text{ kPa}\cdot\text{m}^3/\text{kg}\cdot\text{K})(300 \text{ K})}{150 \text{ kPa}} = 0.8 \text{ m}^3 \\ v_3 &= \frac{mRT_3}{P_3} = \frac{(1.394 \text{ kg})(0.287 \text{ kPa}\cdot\text{m}^3/\text{kg}\cdot\text{K})(396.6 \text{ K})}{400 \text{ kPa}} = 0.3967 \text{ m}^3 \end{aligned}$$

Process 1-2: Isothermal expansion ($T_2 = T_1$)

$$\Delta S_{1-2} = -mR \ln \frac{P_2}{P_1} = (1.394 \text{ kg})(0.287 \text{ kJ/kg}\cdot\text{K}) \ln \frac{150 \text{ kPa}}{400 \text{ kPa}} = 0.3924 \text{ kJ/kg}\cdot\text{K}$$

$$Q_{\text{in},1-2} = T_1 \Delta S_{1-2} = (300 \text{ K})(0.3924 \text{ kJ/K}) = \mathbf{117.7 \text{ kJ}}$$

$$W_{\text{out},1-2} = Q_{\text{in},1-2} = \mathbf{117.7 \text{ kJ}}$$

Process 2-3: Isentropic (reversible-adiabatic) compression ($s_2 = s_1$)

$$W_{\text{in},2-3} = m(u_3 - u_2) = (1.394 \text{ kg})(283.71 - 214.07) \text{ kJ/kg} = \mathbf{97.1 \text{ kJ}}$$

$$Q_{2-3} = \mathbf{0 \text{ kJ}}$$

Process 3-1: Constant pressure compression process ($P_1 = P_3$)

$$W_{\text{in},3-1} = P_3(v_3 - v_1) = (400 \text{ kPa})(0.3967 - 0.3) \text{ m}^3/\text{kg} = \mathbf{37.0 \text{ kJ}}$$

$$Q_{\text{out},3-1} = W_{\text{in},3-1} - m(u_1 - u_3) = 37.0 \text{ kJ} - (1.394 \text{ kg})(214.07 - 283.71) \text{ kJ/kg} = \mathbf{135.8 \text{ kJ}}$$

7-177E A cylinder initially filled with helium gas at a specified state is compressed polytropically to a specified temperature and pressure. The entropy changes of the helium and the surroundings are to be determined, and it is to be assessed if the process is reversible, irreversible, or impossible.

Assumptions 1 Helium is an ideal gas with constant specific heats. 2 The cylinder is stationary and thus the kinetic and potential energy changes are negligible. 3 The thermal energy stored in the cylinder itself is negligible. 4 The compression or expansion process is quasi-equilibrium.

Properties The gas constant of helium is $R = 2.6805 \text{ psia}\cdot\text{ft}^3/\text{lbm}\cdot\text{R} = 0.4961 \text{ Btu}/\text{lbm}\cdot\text{R}$. The specific heats of helium are $c_v = 0.753$ and $c_p = 1.25 \text{ Btu}/\text{lbm}\cdot\text{R}$ (Table A-2E).

Analysis (a) The mass of helium is

$$m = \frac{P_1 V_1}{RT_1} = \frac{(25 \text{ psia})(15 \text{ ft}^3)}{(2.6805 \text{ psia}\cdot\text{ft}^3/\text{lbm}\cdot\text{R})(530 \text{ R})} = 0.264 \text{ lbm}$$

Then the entropy change of helium becomes

$$\begin{aligned} \Delta S_{\text{sys}} = \Delta S_{\text{helium}} &= m \left(c_{p,\text{avg}} \ln \frac{T_2}{T_1} - R \ln \frac{P_2}{P_1} \right) \\ &= (0.264 \text{ lbm}) \left[(1.25 \text{ Btu}/\text{lbm}\cdot\text{R}) \ln \frac{760 \text{ R}}{530 \text{ R}} - (0.4961 \text{ Btu}/\text{lbm}\cdot\text{R}) \ln \frac{70 \text{ psia}}{25 \text{ psia}} \right] = \mathbf{-0.016 \text{ Btu/R}} \end{aligned}$$

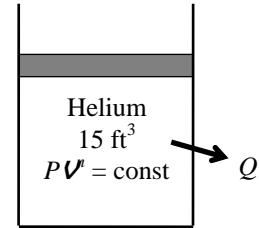

(b) The exponent n and the boundary work for this polytropic process are determined to be

$$\begin{aligned} \frac{P_1 V_1}{T_1} &= \frac{P_2 V_2}{T_2} \longrightarrow V_2 = \frac{T_2}{T_1} \frac{P_1}{P_2} V_1 = \frac{(760 \text{ R})(25 \text{ psia})}{(530 \text{ R})(70 \text{ psia})} (15 \text{ ft}^3) = 7.682 \text{ ft}^3 \\ P_2 V_2^n &= P_1 V_1^n \longrightarrow \left(\frac{P_2}{P_1} \right) = \left(\frac{V_1}{V_2} \right)^n \longrightarrow \left(\frac{70}{25} \right) = \left(\frac{15}{7.682} \right)^n \longrightarrow n = 1.539 \end{aligned}$$

Then the boundary work for this polytropic process can be determined from

$$\begin{aligned} W_{b,\text{in}} &= -\int_1^2 P dV = -\frac{P_2 V_2 - P_1 V_1}{1-n} = -\frac{mR(T_2 - T_1)}{1-n} \\ &= -\frac{(0.264 \text{ lbm})(0.4961 \text{ Btu}/\text{lbm}\cdot\text{R})(760 - 530)\text{R}}{1-1.539} = 55.9 \text{ Btu} \end{aligned}$$

We take the helium in the cylinder as the system, which is a closed system. Taking the direction of heat transfer to be from the cylinder, the energy balance for this stationary closed system can be expressed as

$$\begin{aligned} \underbrace{E_{\text{in}} - E_{\text{out}}}_{\text{Net energy transfer by heat, work, and mass}} &= \underbrace{\Delta E_{\text{system}}}_{\text{Change in internal, kinetic, potential, etc. energies}} \\ -Q_{\text{out}} + W_{b,\text{in}} &= \Delta U = m(u_2 - u_1) \\ -Q_{\text{out}} &= m(u_2 - u_1) - W_{b,\text{in}} \\ Q_{\text{out}} &= W_{b,\text{in}} - mc_v(T_2 - T_1) \end{aligned}$$

Substituting, $Q_{\text{out}} = 55.9 \text{ Btu} - (0.264 \text{ lbm})(0.753 \text{ Btu}/\text{lbm}\cdot\text{R})(760 - 530)\text{R} = 10.2 \text{ Btu}$

Noting that the surroundings undergo a reversible isothermal process, its entropy change becomes

$$\Delta S_{\text{surr}} = \frac{Q_{\text{surr,in}}}{T_{\text{surr}}} = \frac{10.2 \text{ Btu}}{530 \text{ R}} = \mathbf{0.019 \text{ Btu/R}}$$

(c) Noting that the system+surroundings combination can be treated as an isolated system,

$$\Delta S_{\text{total}} = \Delta S_{\text{sys}} + \Delta S_{\text{surr}} = -0.016 + 0.019 = 0.003 \text{ Btu/R} > 0$$

Therefore, the process is **irreversible**.

7-178 A piston-cylinder device contains steam that undergoes a reversible thermodynamic cycle composed of three processes. The work and heat transfer for each process and for the entire cycle are to be determined.

Assumptions 1 All processes are reversible. 2 Kinetic and potential energy changes are negligible.

Analysis The properties of the steam at various states are (Tables A-4 through A-6)

$$\begin{aligned} P_1 = 400 \text{ kPa} & \left\{ \begin{array}{l} u_1 = 2884.5 \text{ kJ/kg} \\ v_1 = 0.71396 \text{ m}^3/\text{kg} \\ s_1 = 7.7399 \text{ kJ/kg}\cdot\text{K} \end{array} \right. \\ T_1 = 350^\circ\text{C} & \\ P_2 = 150 \text{ kPa} & \left\{ \begin{array}{l} u_2 = 2888.0 \text{ kJ/kg} \\ s_2 = 8.1983 \text{ kJ/kg}\cdot\text{K} \end{array} \right. \\ T_2 = 350^\circ\text{C} & \\ P_3 = 400 \text{ kPa} & \left\{ \begin{array}{l} u_3 = 3132.9 \text{ kJ/kg} \\ v_3 = 0.89148 \text{ m}^3/\text{kg} \end{array} \right. \\ s_3 = s_2 = 8.1983 \text{ kJ/kg}\cdot\text{K} & \end{aligned}$$

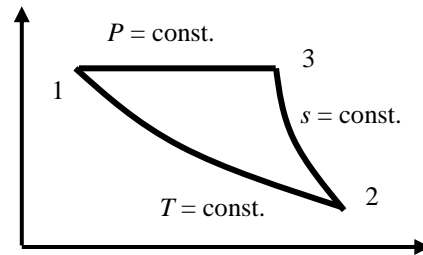

The mass of the steam in the cylinder and the volume at state 3 are

$$\begin{aligned} m &= \frac{V_1}{v_1} = \frac{0.3 \text{ m}^3}{0.71396 \text{ m}^3/\text{kg}} = 0.4202 \text{ kg} \\ V_3 &= m v_3 = (0.4202 \text{ kg})(0.89148 \text{ m}^3/\text{kg}) = 0.3746 \text{ m}^3 \end{aligned}$$

Process 1-2: Isothermal expansion ($T_2 = T_1$)

$$\Delta S_{1-2} = m(s_2 - s_1) = (0.4202 \text{ kg})(8.1983 - 7.7399) \text{ kJ/kg}\cdot\text{K} = 0.1926 \text{ kJ/kg}\cdot\text{K}$$

$$Q_{\text{in},1-2} = T_1 \Delta S_{1-2} = (350 + 273 \text{ K})(0.1926 \text{ kJ/K}) = 120 \text{ kJ}$$

$$W_{\text{out},1-2} = Q_{\text{in},1-2} - m(u_2 - u_1) = 120 \text{ kJ} - (0.4202 \text{ kg})(2888.0 - 2884.5) \text{ kJ/kg} = 118.5 \text{ kJ}$$

Process 2-3: Isentropic (reversible-adiabatic) compression ($s_3 = s_2$)

$$W_{\text{in},2-3} = m(u_3 - u_2) = (0.4202 \text{ kg})(3132.9 - 2888.0) \text{ kJ/kg} = 102.9 \text{ kJ}$$

$$Q_{2-3} = 0 \text{ kJ}$$

Process 3-1: Constant pressure compression process ($P_1 = P_3$)

$$W_{\text{in},3-1} = P_3(V_3 - V_1) = (400 \text{ kPa})(0.3746 - 0.3) = 29.8 \text{ kJ}$$

$$Q_{\text{out},3-1} = W_{\text{in},3-1} - m(u_1 - u_3) = 29.8 \text{ kJ} - (0.4202 \text{ kg})(2884.5 - 3132.9) = 134.2 \text{ kJ}$$

The net work and net heat transfer are

$$W_{\text{net,in}} = W_{\text{in},3-1} + W_{\text{in},2-3} - W_{\text{out},1-2} = 29.8 + 102.9 - 118.5 = \mathbf{14.2 \text{ kJ}}$$

$$Q_{\text{net,in}} = Q_{\text{in},1-2} - Q_{\text{out},3-1} = 120 - 134.2 = -14.2 \text{ kJ} \longrightarrow Q_{\text{net,out}} = \mathbf{14.2 \text{ kJ}}$$

Discussion The results are not surprising since for a cycle, the net work and heat transfers must be equal to each other.

7-179 An electric resistance heater is doing work on carbon dioxide contained in a rigid tank. The final temperature in the tank, the amount of heat transfer, and the entropy generation are to be determined.

Assumptions 1 Kinetic and potential energy changes are negligible. 2 Carbon dioxide is ideal gas with constant specific heats at room temperature.

Properties The properties of CO₂ at an anticipated average temperature of 350 K are $R = 0.1889 \text{ kPa}\cdot\text{m}^3/\text{kg}\cdot\text{K}$, $c_p = 0.895 \text{ kJ/kg}\cdot\text{K}$, $c_v = 0.706 \text{ kJ/kg}\cdot\text{K}$ (Table A-2b).

Analysis (a) The mass and the final temperature of CO₂ may be determined from ideal gas equation

$$m = \frac{P_1 V}{RT_1} = \frac{(100 \text{ kPa})(0.8 \text{ m}^3)}{(0.1889 \text{ kPa}\cdot\text{m}^3/\text{kg}\cdot\text{K})(250 \text{ K})} = 1.694 \text{ kg}$$

$$T_2 = \frac{P_2 V}{mR} = \frac{(175 \text{ kPa})(0.8 \text{ m}^3)}{(1.694 \text{ kg})(0.1889 \text{ kPa}\cdot\text{m}^3/\text{kg}\cdot\text{K})} = \mathbf{437.5 \text{ K}}$$

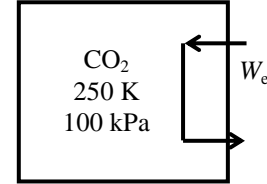

(b) The amount of heat transfer may be determined from an energy balance on the system

$$Q_{\text{out}} = \dot{E}_{e,\text{in}} \Delta t - mc_v(T_2 - T_1)$$

$$= (0.5 \text{ kW})(40 \times 60 \text{ s}) - (1.694 \text{ kg})(0.706 \text{ kJ/kg}\cdot\text{K})(437.5 - 250) \text{ K} = \mathbf{975.8 \text{ kJ}}$$

(c) The entropy generation associated with this process may be obtained by calculating total entropy change, which is the sum of the entropy changes of CO₂ and the surroundings

$$S_{\text{gen}} = \Delta S_{\text{CO}_2} + \Delta S_{\text{surr}} = m \left(c_p \ln \frac{T_2}{T_1} - R \ln \frac{P_2}{P_1} \right) + \frac{Q_{\text{out}}}{T_{\text{surr}}}$$

$$= (1.694 \text{ kg}) \left[(0.895 \text{ kJ/kg}\cdot\text{K}) \ln \frac{437.5 \text{ K}}{250 \text{ K}} - (0.1889 \text{ kJ/kg}\cdot\text{K}) \ln \frac{175 \text{ kPa}}{100 \text{ kPa}} \right] + \frac{975.8 \text{ kJ}}{300 \text{ K}}$$

$$= \mathbf{3.92 \text{ kJ/K}}$$

7-180 Heat is lost from the helium as it is throttled in a throttling valve. The exit pressure and temperature of helium and the entropy generation are to be determined.

Assumptions 1 Steady operating conditions exist. 2 Kinetic and potential energy changes are negligible. 3 Helium is an ideal gas with constant specific heats.

Properties The properties of helium are $R = 2.0769 \text{ kPa}\cdot\text{m}^3/\text{kg}\cdot\text{K}$, $c_p = 5.1926 \text{ kJ/kg}\cdot\text{K}$ (Table A-2a).

Analysis (a) The final temperature of helium may be determined from an energy balance on the control volume

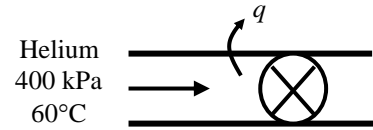

$$q_{\text{out}} = c_p(T_1 - T_2) \longrightarrow T_2 = T_1 - \frac{q_{\text{out}}}{c_p} = 60^\circ\text{C} - \frac{1.75 \text{ kJ/kg}}{5.1926 \text{ kJ/kg}\cdot^\circ\text{C}} = \mathbf{59.7^\circ\text{C}} = 332.7 \text{ K}$$

The final pressure may be determined from the relation for the entropy change of helium

$$\Delta s_{\text{He}} = c_p \ln \frac{T_2}{T_1} - R \ln \frac{P_2}{P_1}$$

$$0.34 \text{ kJ/kg}\cdot\text{K} = (5.1926 \text{ kJ/kg}\cdot\text{K}) \ln \frac{332.7 \text{ K}}{333 \text{ K}} - (2.0769 \text{ kJ/kg}\cdot\text{K}) \ln \frac{P_2}{400 \text{ kPa}}$$

$$P_2 = \mathbf{339 \text{ kPa}}$$

(b) The entropy generation associated with this process may be obtained by adding the entropy change of helium as it flows in the valve and the entropy change of the surroundings

$$s_{\text{gen}} = \Delta s_{\text{He}} + \Delta s_{\text{surr}} = \Delta s_{\text{He}} + \frac{q_{\text{out}}}{T_{\text{surr}}} = 0.34 \text{ kJ/kg}\cdot\text{K} + \frac{1.75 \text{ kJ/kg}}{(25 + 273) \text{ K}} = \mathbf{0.346 \text{ kJ/kg}\cdot\text{K}}$$

7-181 Refrigerant-134a is vaporized by air in the evaporator of an air-conditioner. For specified flow rates, the exit temperature of air and the rate of entropy generation are to be determined for the cases of an insulated and uninsulated evaporator.

Assumptions 1 This is a steady-flow process since there is no change with time. **2** Kinetic and potential energy changes are negligible. **3** There are no work interactions. **4** Air is an ideal gas with constant specific heats at room temperature.

Properties The gas constant of air is $0.287 \text{ kPa}\cdot\text{m}^3/\text{kg}\cdot\text{K}$ (Table A-1). The constant pressure specific heat of air at room temperature is $c_p = 1.005 \text{ kJ/kg}\cdot\text{K}$ (Table A-2). The properties of R-134a at the inlet and the exit states are (Tables A-11 through A-13)

$$P_1 = 120 \text{ kPa} \left\{ \begin{array}{l} h_1 = h_f + x_1 h_{fg} = 22.47 + 0.3 \times 214.52 = 86.83 \text{ kJ/kg} \\ x_1 = 0.3 \end{array} \right. \left\{ \begin{array}{l} s_1 = s_f + x_1 s_{fg} = 0.09269 + 0.3(0.85520) = 0.3492 \text{ kJ/kg}\cdot\text{K} \end{array} \right.$$

$$T_2 = 120 \text{ kPa} \left\{ \begin{array}{l} h_2 = h_{g@120 \text{ kPa}} = 236.99 \text{ kJ/kg} \\ \text{sat. vapor} \end{array} \right. \left\{ \begin{array}{l} s_2 = h_{g@120 \text{ kPa}} = 0.9479 \text{ kJ/kg}\cdot\text{K} \end{array} \right.$$

Analysis (a) The mass flow rate of air is

$$\dot{m}_{\text{air}} = \frac{P_3 \dot{V}_3}{RT_3} = \frac{(100 \text{ kPa})(6 \text{ m}^3/\text{min})}{(0.287 \text{ kPa}\cdot\text{m}^3/\text{kg}\cdot\text{K})(300 \text{ K})} = 6.968 \text{ kg/min}$$

We take the entire heat exchanger as the system, which is a control volume. The mass and energy balances for this steady-flow system can be expressed in the rate form as

Mass balance (for each fluid stream):

$$\dot{m}_{\text{in}} - \dot{m}_{\text{out}} = \Delta \dot{m}_{\text{system}} \stackrel{\phi=0 \text{ (steady)}}{=} 0 \rightarrow \dot{m}_{\text{in}} = \dot{m}_{\text{out}} \rightarrow \dot{m}_1 = \dot{m}_2 = \dot{m}_{\text{air}} \quad \text{and} \quad \dot{m}_3 = \dot{m}_4 = \dot{m}_R$$

Energy balance (for the entire heat exchanger):

$$\underbrace{\dot{E}_{\text{in}} - \dot{E}_{\text{out}}}_{\text{Rate of net energy transfer by heat, work, and mass}} = \underbrace{\Delta \dot{E}_{\text{system}}}_{\text{Rate of change in internal, kinetic, potential, etc. energies}} \stackrel{\phi=0 \text{ (steady)}}{=} 0$$

$$\dot{E}_{\text{in}} = \dot{E}_{\text{out}}$$

$$\dot{m}_1 h_1 + \dot{m}_3 h_3 = \dot{m}_2 h_2 + \dot{m}_4 h_4 \quad (\text{since } \dot{Q} = \dot{W} = \Delta \text{ke} \cong \Delta \text{pe} \cong 0)$$

Combining the two, $\dot{m}_R (h_2 - h_1) = \dot{m}_{\text{air}} (h_3 - h_4) = \dot{m}_{\text{air}} c_p (T_3 - T_4)$

Solving for T_4 ,

$$T_4 = T_3 - \frac{\dot{m}_R (h_2 - h_1)}{\dot{m}_{\text{air}} c_p}$$

Substituting,

$$T_4 = 27^\circ\text{C} - \frac{(2 \text{ kg/min})(236.99 - 86.83) \text{ kJ/kg}}{(6.968 \text{ kg/min})(1.005 \text{ kJ/kg}\cdot\text{K})} = -15.9^\circ\text{C} = 257.1 \text{ K}$$

Noting that the condenser is well-insulated and thus heat transfer is negligible, the entropy balance for this steady-flow system can be expressed as

$$\underbrace{\dot{S}_{\text{in}} - \dot{S}_{\text{out}}}_{\text{Rate of net entropy transfer by heat and mass}} + \underbrace{\dot{S}_{\text{gen}}}_{\text{Rate of entropy generation}} = \underbrace{\Delta \dot{S}_{\text{system}}}_{\text{Rate of change of entropy}} \stackrel{\phi=0 \text{ (steady)}}{=} 0$$

$$\dot{m}_1 s_1 + \dot{m}_3 s_3 - \dot{m}_2 s_2 - \dot{m}_4 s_4 + \dot{S}_{\text{gen}} = 0 \quad (\text{since } \dot{Q} = 0)$$

$$\dot{m}_R s_1 + \dot{m}_{\text{air}} s_3 - \dot{m}_R s_2 - \dot{m}_{\text{air}} s_4 + \dot{S}_{\text{gen}} = 0$$

or,

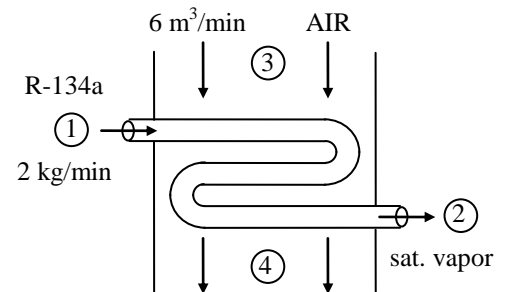

$$\dot{S}_{\text{gen}} = \dot{m}_R(s_2 - s_1) + \dot{m}_{\text{air}}(s_4 - s_3)$$

where

$$s_4 - s_3 = c_p \ln \frac{T_4}{T_3} - R \ln \frac{P_4^{\phi^0}}{P_3} = c_p \ln \frac{T_4}{T_3} = (1.005 \text{ kJ/kg} \cdot \text{K}) \ln \frac{257.1 \text{ K}}{300 \text{ K}} = -0.1551 \text{ kJ/kg} \cdot \text{K}$$

Substituting,

$$\begin{aligned} \dot{S}_{\text{gen}} &= (2 \text{ kg/min})(0.9479 - 0.3492 \text{ kJ/kg} \cdot \text{K}) + (6.968 \text{ kg/min})(-0.1551 \text{ kJ/kg} \cdot \text{K}) \\ &= 0.1175 \text{ kJ/min} \cdot \text{K} \\ &= \mathbf{0.00196 \text{ kW/K}} \end{aligned}$$

(b) When there is a heat gain from the surroundings at a rate of 30 kJ/min, the steady-flow energy equation reduces to

$$\dot{Q}_{\text{in}} = \dot{m}_R(h_2 - h_1) + \dot{m}_{\text{air}}c_p(T_4 - T_3)$$

Solving for T_4 ,

$$T_4 = T_3 + \frac{\dot{Q}_{\text{in}} - \dot{m}_R(h_2 - h_1)}{\dot{m}_{\text{air}}c_p}$$

Substituting,

$$T_4 = 27^\circ\text{C} + \frac{(30 \text{ kJ/min}) - (2 \text{ kg/min})(236.99 - 86.83) \text{ kJ/kg}}{(6.968 \text{ kg/min})(1.005 \text{ kJ/kg} \cdot \text{K})} = \mathbf{-11.6^\circ\text{C}} = 261.4 \text{ K}$$

The entropy generation in this case is determined by applying the entropy balance on an *extended system* that includes the evaporator and its immediate surroundings so that the boundary temperature of the extended system is the temperature of the surrounding air at all times. The entropy balance for the extended system can be expressed as

$$\underbrace{\dot{S}_{\text{in}} - \dot{S}_{\text{out}}}_{\text{Rate of net entropy transfer by heat and mass}} + \underbrace{\dot{S}_{\text{gen}}}_{\text{Rate of entropy generation}} = \underbrace{\Delta \dot{S}_{\text{system}}}_{\text{Rate of change of entropy}} \overset{\phi^0(\text{steady})}{=} 0$$

$$\frac{\dot{Q}_{\text{in}}}{T_{\text{b,out}}} + \dot{m}_1 s_1 + \dot{m}_3 s_3 - \dot{m}_2 s_2 - \dot{m}_4 s_4 + \dot{S}_{\text{gen}} = 0$$

$$\frac{\dot{Q}_{\text{in}}}{T_{\text{surr}}} + \dot{m}_R s_1 + \dot{m}_{\text{air}} s_3 - \dot{m}_R s_2 - \dot{m}_{\text{air}} s_4 + \dot{S}_{\text{gen}} = 0$$

or

$$\dot{S}_{\text{gen}} = \dot{m}_R(s_2 - s_1) + \dot{m}_{\text{air}}(s_4 - s_3) - \frac{\dot{Q}_{\text{in}}}{T_0}$$

where

$$s_4 - s_3 = c_p \ln \frac{T_4}{T_3} - R \ln \frac{P_4^{\phi^0}}{P_3} = (1.005 \text{ kJ/kg} \cdot \text{K}) \ln \frac{261.4 \text{ K}}{300 \text{ K}} = -0.1384 \text{ kJ/kg} \cdot \text{K}$$

Substituting,

$$\begin{aligned} \dot{S}_{\text{gen}} &= (2 \text{ kg/min})(0.9479 - 0.3492) \text{ kJ/kg} \cdot \text{K} + (6.968 \text{ kg/min})(-0.1384 \text{ kJ/kg} \cdot \text{K}) - \frac{30 \text{ kJ/min}}{305 \text{ K}} \\ &= 0.1348 \text{ kJ/min} \cdot \text{K} = \mathbf{0.00225 \text{ kW/K}} \end{aligned}$$

Discussion Note that the rate of entropy generation in the second case is greater because of the irreversibility associated with heat transfer between the evaporator and the surrounding air.

7-182 Refrigerant-134a is compressed in a compressor. The rate of heat loss from the compressor, the exit temperature of R-134a, and the rate of entropy generation are to be determined.

Assumptions 1 Steady operating conditions exist. 2 Kinetic and potential energy changes are negligible.

Analysis (a) The properties of R-134a at the inlet of the compressor are (Table A-12)

$$P_1 = 160 \text{ kPa} \left. \begin{array}{l} \nu_1 = 0.12355 \text{ m}^3/\text{kg} \\ h_1 = 241.14 \text{ kJ/kg} \\ s_1 = 0.94202 \text{ kJ/kg}\cdot\text{K} \end{array} \right\} x_1 = 1$$

The mass flow rate of the refrigerant is

$$\dot{m} = \frac{\dot{V}_1}{\nu_1} = \frac{0.03 \text{ m}^3/\text{s}}{0.12355 \text{ m}^3/\text{kg}} = 0.2428 \text{ kg/s}$$

Given the entropy increase of the surroundings, the heat lost from the compressor is

$$\Delta \dot{S}_{\text{surr}} = \frac{\dot{Q}_{\text{out}}}{T_{\text{surr}}} \longrightarrow \dot{Q}_{\text{out}} = T_{\text{surr}} \Delta \dot{S}_{\text{surr}} = (20 + 273 \text{ K})(0.008 \text{ kW/K}) = \mathbf{2.344 \text{ kW}}$$

(b) An energy balance on the compressor gives

$$\dot{W}_{\text{in}} - \dot{Q}_{\text{out}} = \dot{m}(h_2 - h_1)$$

$$10 \text{ kW} - 2.344 \text{ kW} = (0.2428 \text{ kg/s})(h_2 - 241.14) \text{ kJ/kg} \longrightarrow h_2 = 272.67 \text{ kJ/kg}$$

The exit state is now fixed. Then,

$$P_2 = 800 \text{ kPa} \left. \begin{array}{l} T_2 = \mathbf{36.4^\circ\text{C}} \\ h_2 = 272.67 \text{ kJ/kg} \\ s_2 = 0.93589 \text{ kJ/kg}\cdot\text{K} \end{array} \right\}$$

(c) The entropy generation associated with this process may be obtained by adding the entropy change of R-134a as it flows in the compressor and the entropy change of the surroundings

$$\begin{aligned} \dot{S}_{\text{gen}} &= \Delta \dot{S}_{\text{R}} + \Delta \dot{S}_{\text{surr}} = \dot{m}(s_2 - s_1) + \Delta \dot{S}_{\text{surr}} \\ &= (0.2428 \text{ kg/s})(0.93589 - 0.94202) \text{ kJ/kg}\cdot\text{K} + 0.008 \text{ kW/K} \\ &= \mathbf{0.00651 \text{ kJ/K}} \end{aligned}$$

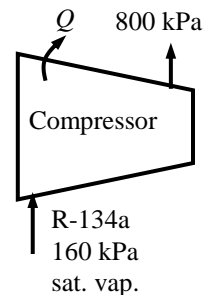

7-183 Air flows in an adiabatic nozzle. The isentropic efficiency, the exit velocity, and the entropy generation are to be determined.

Properties The gas constant of air is $R = 0.287 \text{ kJ/kg}\cdot\text{K}$ (Table A-1).

Assumptions 1 Steady operating conditions exist. 2 Potential energy changes are negligible.

Analysis (a) (b) Using variable specific heats, the properties can be determined from air table as follows

$$\begin{aligned}
 T_1 = 400 \text{ K} &\longrightarrow h_1 = 400.98 \text{ kJ/kg} \\
 &\longrightarrow s_1^0 = 1.99194 \text{ kJ/kg}\cdot\text{K} \\
 &\quad P_{r1} = 3.806 \\
 T_2 = 350 \text{ K} &\longrightarrow h_2 = 350.49 \text{ kJ/kg} \\
 &\quad s_2^0 = 1.85708 \text{ kJ/kg}\cdot\text{K} \\
 P_{r2} = \frac{P_2}{P_1} P_{r1} = \frac{300 \text{ kPa}}{500 \text{ kPa}} (3.806) = 2.2836 &\longrightarrow h_{2s} = 346.31 \text{ kJ/kg}
 \end{aligned}$$

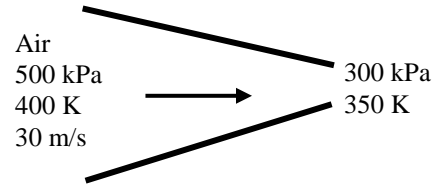

Energy balances on the control volume for the actual and isentropic processes give

$$\begin{aligned}
 h_1 + \frac{V_1^2}{2} &= h_2 + \frac{V_2^2}{2} \\
 400.98 \text{ kJ/kg} + \frac{(30 \text{ m/s})^2}{2} \left(\frac{1 \text{ kJ/kg}}{1000 \text{ m}^2/\text{s}^2} \right) &= 350.49 \text{ kJ/kg} + \frac{V_2^2}{2} \left(\frac{1 \text{ kJ/kg}}{1000 \text{ m}^2/\text{s}^2} \right) \\
 V_2 &= \mathbf{319.1 \text{ m/s}}
 \end{aligned}$$

$$\begin{aligned}
 h_1 + \frac{V_1^2}{2} &= h_{2s} + \frac{V_{2s}^2}{2} \\
 400.98 \text{ kJ/kg} + \frac{(30 \text{ m/s})^2}{2} \left(\frac{1 \text{ kJ/kg}}{1000 \text{ m}^2/\text{s}^2} \right) &= 346.31 \text{ kJ/kg} + \frac{V_{2s}^2}{2} \left(\frac{1 \text{ kJ/kg}}{1000 \text{ m}^2/\text{s}^2} \right) \\
 V_{2s} &= 331.8 \text{ m/s}
 \end{aligned}$$

The isentropic efficiency is determined from its definition,

$$\eta_N = \frac{V_2^2}{V_{2s}^2} = \frac{(319.1 \text{ m/s})^2}{(331.8 \text{ m/s})^2} = \mathbf{0.925}$$

(c) Since the nozzle is adiabatic, the entropy generation is equal to the entropy increase of the air as it flows in the nozzle

$$\begin{aligned}
 s_{\text{gen}} &= \Delta s_{\text{air}} = s_2^0 - s_1^0 - R \ln \frac{P_2}{P_1} \\
 &= (1.85708 - 1.99194) \text{ kJ/kg}\cdot\text{K} - (0.287 \text{ kJ/kg}\cdot\text{K}) \ln \frac{300 \text{ kPa}}{500 \text{ kPa}} \\
 &= \mathbf{0.0118 \text{ kJ/kg}\cdot\text{K}}
 \end{aligned}$$

7-184 Helium gas is compressed in an adiabatic closed system with an isentropic efficiency of 80%. The work input and the final temperature are to be determined.

Assumptions 1 Kinetic and potential energy changes are negligible. 3 The device is adiabatic and thus heat transfer is negligible. 4 Helium is an ideal gas.

Properties The properties of helium are $c_v = 3.1156 \text{ kJ/kg}\cdot\text{K}$ and $k = 1.667$ (Table A-2b).

Analysis We take the helium as the system. This is a *closed system* since no mass crosses the boundaries of the system. The energy balance for this system can be expressed as

$$\underbrace{E_{\text{in}} - E_{\text{out}}}_{\substack{\text{Net energy transfer} \\ \text{by heat, work, and mass}}} = \underbrace{\Delta E_{\text{system}}}_{\substack{\text{Change in internal, kinetic,} \\ \text{potential, etc. energies}}}$$

$$W_{\text{in}} = \Delta U = m(u_2 - u_1) = mc_v(T_2 - T_1)$$

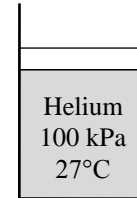

The isentropic exit temperature is

$$T_{2s} = T_1 \left(\frac{P_2}{P_1} \right)^{(k-1)/k} = (300 \text{ K}) \left(\frac{900 \text{ kPa}}{100 \text{ kPa}} \right)^{0.667/1.667} = 722.7 \text{ K}$$

The work input during isentropic process would be

$$W_{s,\text{in}} = mc_v(T_{2s} - T_1) = (3 \text{ kg})(3.1156 \text{ kJ/kg}\cdot\text{K})(722.7 - 300)\text{K} = 3950 \text{ kJ}$$

The work input during the actual process is

$$W_{\text{in}} = \frac{W_{s,\text{in}}}{\eta} = \frac{3950 \text{ kJ}}{0.80} = \mathbf{4938 \text{ kJ}}$$

7-185 The claim of an inventor that an adiabatic steady-flow device produces a specified amount of power is to be evaluated.

Assumptions **1** Kinetic and potential energy changes are negligible. **3** The device is adiabatic and thus heat transfer is negligible. **4** Air is an ideal gas with constant specific heats.

Properties The properties of air at the anticipated average temperature of 400 K are $c_p = 1.013 \text{ kJ/kg}\cdot\text{K}$ and $k = 1.395$ (Table A-2b).

Analysis We take the steady-flow device as the system, which is a control volume since mass crosses the boundary. Noting that one fluid stream enters and leaves the turbine, the energy balance for this steady-flow system can be expressed in the rate form as

$$\underbrace{\dot{E}_{\text{in}} - \dot{E}_{\text{out}}}_{\text{Rate of net energy transfer by heat, work, and mass}} = \underbrace{\Delta \dot{E}_{\text{system}}^{\approx 0} (\text{steady})}_{\text{Rate of change in internal, kinetic, potential, etc. energies}} = 0$$

$$\dot{E}_{\text{in}} = \dot{E}_{\text{out}}$$

$$\dot{m}h_1 = \dot{W}_{\text{out}} + \dot{m}h_2 \quad (\text{since } \dot{Q} \cong \Delta \text{ke} \cong \Delta \text{pe} \cong 0)$$

$$\dot{W}_{\text{out}} = \dot{m}(h_1 - h_2) \cong \dot{m}c_p(T_1 - T_2)$$

The adiabatic device would produce the maximum power if the process is isentropic. The isentropic exit temperature is

$$T_{2s} = T_1 \left(\frac{P_2}{P_1} \right)^{(k-1)/k} = (573 \text{ K}) \left(\frac{100 \text{ kPa}}{1200 \text{ kPa}} \right)^{0.395/1.395} = 283.5 \text{ K}$$

The maximum power this device can produce is then

$$\dot{W}_{s,\text{out}} = \dot{m}c_p(T_1 - T_{2s}) = (1 \text{ kg/s})(1.013 \text{ kJ/kg}\cdot\text{K})(573 - 283.5) \text{ K} = \mathbf{293 \text{ kW}}$$

This is greater than the power claim of the inventor, and thus the claim is valid.

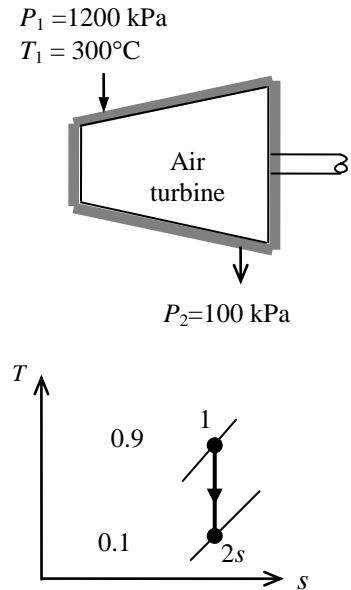

7-186 A gas is adiabatically expanded in a piston-cylinder device with a specified isentropic efficiency. It is to be determined if air or neon will produce more work.

Assumptions **1** Kinetic and potential energy changes are negligible. **3** The device is adiabatic and thus heat transfer is negligible. **4** Air and helium are ideal gases.

Properties The properties of air at room temperature are $c_v = 0.718 \text{ kJ/kg}\cdot\text{K}$ and $k = 1.4$. The properties of neon at room temperature are $c_v = 0.6179 \text{ kJ/kg}\cdot\text{K}$ and $k = 1.667$ (Table A-2a).

Analysis We take the gas as the system. This is a *closed system* since no mass crosses the boundaries of the system. The energy balance for this system can be expressed as

$$\underbrace{E_{\text{in}} - E_{\text{out}}}_{\substack{\text{Net energy transfer} \\ \text{by heat, work, and mass}}} = \underbrace{\Delta E_{\text{system}}}_{\substack{\text{Change in internal, kinetic,} \\ \text{potential, etc. energies}}}$$

$$-W_{\text{out}} = \Delta U = m(u_2 - u_1) = mc_v(T_2 - T_1)$$

$$W_{\text{out}} = mc_v(T_1 - T_2)$$

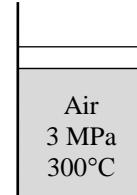

The isentropic exit temperature is

$$T_{2s} = T_1 \left(\frac{P_2}{P_1} \right)^{(k-1)/k} = (300 + 273 \text{ K}) \left(\frac{80 \text{ kPa}}{3000 \text{ kPa}} \right)^{0.4/1.4} = 203.4 \text{ K}$$

The work output during the actual process is

$$w_{\text{in}} = \eta c_v (T_1 - T_{2s}) = (0.90)(0.718 \text{ kJ/kg}\cdot\text{K})(573 - 203.4)\text{K} = \mathbf{239 \text{ kJ/kg}}$$

Repeating the same calculations for neon,

$$T_{2s} = T_1 \left(\frac{P_2}{P_1} \right)^{(k-1)/k} = (300 + 273 \text{ K}) \left(\frac{80 \text{ kPa}}{3000 \text{ kPa}} \right)^{0.667/1.667} = 134.4 \text{ K}$$

$$w_{\text{in}} = \eta c_v (T_1 - T_{2s}) = (0.80)(0.6179 \text{ kJ/kg}\cdot\text{K})(573 - 134.4)\text{K} = \mathbf{217 \text{ kJ/kg}}$$

Air will produce more work.

7-187 Refrigerant-134a is expanded adiabatically in a capillary tube. The rate of entropy generation is to be determined.

Assumptions **1** Steady operating conditions exist. **2** Kinetic and potential energy changes are negligible.

Analysis The rate of entropy generation within the expansion device during this process can be determined by applying the rate form of the entropy balance on the system. Noting that the system is adiabatic and thus there is no heat transfer, the entropy balance for this steady-flow system can be expressed as

$$\underbrace{\dot{S}_{\text{in}} - \dot{S}_{\text{out}}}_{\text{Rate of net entropy transfer by heat and mass}} + \underbrace{\dot{S}_{\text{gen}}}_{\text{Rate of entropy generation}} = \underbrace{\Delta \dot{S}_{\text{system}}}_{\text{Rate of change of entropy}} \stackrel{\neq 0 \text{ (steady)}}{=} 0$$

$$\dot{m}_1 s_1 - \dot{m}_2 s_2 + \dot{S}_{\text{gen}} = 0$$

$$\dot{S}_{\text{gen}} = \dot{m}(s_2 - s_1)$$

$$s_{\text{gen}} = s_2 - s_1$$

R-134a
70°C
sat. liq.

Capillary tube
→

-20°C

It may be easily shown with an energy balance that the enthalpy remains constant during the throttling process. The properties of the refrigerant at the inlet and exit states are (Tables A-11 through A-13)

$$\left. \begin{array}{l} T_1 = 70^\circ\text{C} \\ x_1 = 0 \end{array} \right\} \begin{array}{l} h_1 = 156.15 \text{ kJ/kg} \cdot \text{K} \\ s_1 = 0.53763 \text{ kJ/kg} \cdot \text{K} \end{array}$$

$$\left. \begin{array}{l} T_2 = -20^\circ\text{C} \\ h_2 = h_1 = 156.15 \text{ kJ/kg} \cdot \text{K} \end{array} \right\} \begin{array}{l} x_2 = \frac{h_2 - h_f}{h_{fg}} = \frac{156.15 - 25.47}{212.96} = 0.6136 \\ s_2 = s_f + x_2 s_{fg} = 0.10456 + (0.6136)(0.84119) = 0.62075 \text{ kJ/kg} \cdot \text{K} \end{array}$$

Substituting,

$$\dot{S}_{\text{gen}} = \dot{m}(s_2 - s_1) = (0.2 \text{ kg/s})(0.62075 - 0.53763) \text{ kJ/kg} \cdot \text{K} = \mathbf{0.0166 \text{ kW/K}}$$

7-188 The work input and the entropy generation are to be determined for the compression of saturated liquid water in a pump and that of saturated vapor in a compressor.

Assumptions 1 Steady operating conditions exist. 2 Kinetic and potential energy changes are negligible. 3 Heat transfer to or from the fluid is zero.

Analysis Pump Analysis: (Properties are obtained from EES)

$$\left. \begin{array}{l} P_1 = 100 \text{ kPa} \\ x_1 = 0 \text{ (sat. liq.)} \end{array} \right\} \begin{array}{l} h_1 = 417.51 \text{ kJ/kg} \\ s_1 = 1.3028 \text{ kJ/kg}\cdot\text{K} \end{array} \quad \left. \begin{array}{l} P_2 = 1 \text{ MPa} \\ s_2 = s_1 \end{array} \right\} h_{2s} = 418.45 \text{ kJ/kg}$$

$$h_2 = h_1 + \frac{h_{2s} - h_1}{\eta_P} = 417.51 + \frac{418.45 - 417.51}{0.85} = 418.61 \text{ kJ/kg}$$

$$\left. \begin{array}{l} P_2 = 1 \text{ MPa} \\ h_2 = 418.61 \text{ kJ/kg} \end{array} \right\} s_2 = 1.3032 \text{ kJ/kg}\cdot\text{K}$$

$$w_P = h_2 - h_1 = 418.61 - 417.51 = \mathbf{1.10 \text{ kJ/kg}}$$

$$s_{\text{gen,P}} = s_2 - s_1 = 1.3032 - 1.3028 = \mathbf{0.0004 \text{ kJ/kg}\cdot\text{K}}$$

Compressor Analysis:

$$\left. \begin{array}{l} P_1 = 100 \text{ kPa} \\ x_1 = 1 \text{ (sat. vap.)} \end{array} \right\} \begin{array}{l} h_1 = 2675.0 \text{ kJ/kg} \\ s_1 = 7.3589 \text{ kJ/kg}\cdot\text{K} \end{array} \quad \left. \begin{array}{l} P_2 = 1 \text{ MPa} \\ s_2 = s_1 \end{array} \right\} h_{2s} = 3193.6 \text{ kJ/kg}$$

$$h_2 = h_1 + \frac{h_{2s} - h_1}{\eta_C} = 2675.0 + \frac{3193.6 - 2675.0}{0.85} = 3285.1 \text{ kJ/kg}$$

$$\left. \begin{array}{l} P_2 = 1 \text{ MPa} \\ h_2 = 3285.1 \text{ kJ/kg} \end{array} \right\} s_2 = 7.4974 \text{ kJ/kg}\cdot\text{K}$$

$$w_C = h_2 - h_1 = 3285.1 - 2675.0 = \mathbf{610.1 \text{ kJ/kg}}$$

$$s_{\text{gen,C}} = s_2 - s_1 = 7.4974 - 7.3589 = \mathbf{0.1384 \text{ kJ/kg}\cdot\text{K}}$$

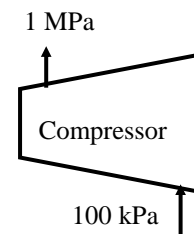
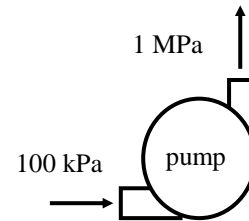

7-189 Air is compressed in a compressor that is intentionally cooled. The work input, the isothermal efficiency, and the entropy generation are to be determined.

Assumptions 1 Steady operating conditions exist. 2 Kinetic and potential energy changes are negligible. 3 Air is an ideal gas with constant specific heats.

Properties The gas constant of air is $R = 0.287 \text{ kJ/kg}\cdot\text{K}$ and the specific heat of air at an average temperature of $(20+300)/2 = 160^\circ\text{C} = 433 \text{ K}$ is $c_p = 1.018 \text{ kJ/kg}\cdot\text{K}$ (Table A-2).

Analysis (a) The power input is determined from an energy balance on the control volume

$$\begin{aligned}\dot{W}_C &= \dot{m}c_p(T_2 - T_1) + \dot{Q}_{\text{out}} \\ &= (0.4 \text{ kg/s})(1.018 \text{ kJ/kg}\cdot^\circ\text{C})(300 - 20)^\circ\text{C} + 15 \text{ kW} \\ &= \mathbf{129.0 \text{ kW}}\end{aligned}$$

(b) The power input for a reversible-isothermal process is given by

$$\dot{W}_{T=\text{const.}} = \dot{m}RT_1 \ln \frac{P_2}{P_1} = (0.4 \text{ kg/s})(0.287 \text{ kJ/kg}\cdot\text{K})(20 + 273 \text{ K}) \ln \left(\frac{1200 \text{ kPa}}{100 \text{ kPa}} \right) = 83.6 \text{ kW}$$

Then, the isothermal efficiency of the compressor becomes

$$\eta_T = \frac{\dot{W}_{T=\text{const.}}}{\dot{W}_C} = \frac{83.6 \text{ kW}}{129.0 \text{ kW}} = \mathbf{0.648}$$

(c) The rate of entropy generation associated with this process may be obtained by adding the rate of entropy change of air as it flows in the compressor and the rate of entropy change of the surroundings

$$\begin{aligned}\dot{S}_{\text{gen}} &= \Delta\dot{S}_{\text{air}} + \Delta\dot{S}_{\text{surr}} = c_p \ln \frac{T_2}{T_1} - R \ln \frac{P_2}{P_1} + \frac{\dot{Q}_{\text{out}}}{T_{\text{surr}}} \\ &= (1.018 \text{ kJ/kg}\cdot\text{K}) \ln \frac{300 + 273 \text{ K}}{20 + 273 \text{ K}} - (0.287 \text{ kJ/kg}\cdot\text{K}) \ln \frac{1200 \text{ kPa}}{100 \text{ kPa}} + \frac{15 \text{ kW}}{(20 + 273) \text{ K}} \\ &= \mathbf{0.0390 \text{ kW/K}}\end{aligned}$$

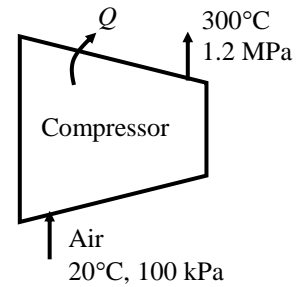

7-190 Air is compressed steadily by a compressor from a specified state to a specified pressure. The minimum power input required is to be determined for the cases of adiabatic and isothermal operation.

Assumptions 1 This is a steady-flow process since there is no change with time. **2** Kinetic and potential energy changes are negligible. **3** Air is an ideal gas with variable specific heats. **4** The process is reversible since the work input to the compressor will be minimum when the compression process is reversible.

Properties The gas constant of air is $R = 0.287 \text{ kJ/kg}\cdot\text{K}$ (Table A-1).

Analysis (a) For the adiabatic case, the process will be reversible and adiabatic (i.e., isentropic), thus the isentropic relations are applicable.

$$T_1 = 290 \text{ K} \longrightarrow P_{r_1} = 1.2311 \text{ and } h_1 = 290.16 \text{ kJ/kg}$$

and

$$P_{r_2} = \frac{P_2}{P_1} P_{r_1} = \frac{700 \text{ kPa}}{100 \text{ kPa}} (1.2311) = 8.6177 \longrightarrow \begin{matrix} T_2 = 503.3 \text{ K} \\ h_2 = 506.45 \text{ kJ/kg} \end{matrix}$$

The energy balance for the compressor, which is a steady-flow system, can be expressed in the rate form as

$$\underbrace{\dot{E}_{\text{in}} - \dot{E}_{\text{out}}}_{\text{Rate of net energy transfer by heat, work, and mass}} = \underbrace{\Delta \dot{E}_{\text{system}}^{\phi_0} (\text{steady})}_{\text{Rate of change in internal, kinetic, potential, etc. energies}} = 0$$

$$\dot{E}_{\text{in}} = \dot{E}_{\text{out}}$$

$$\dot{W}_{\text{in}} + \dot{m}h_1 = \dot{m}h_2 \longrightarrow \dot{W}_{\text{in}} = \dot{m}(h_2 - h_1)$$

Substituting, the power input to the compressor is determined to be

$$\dot{W}_{\text{in}} = (5/60 \text{ kg/s})(506.45 - 290.16) \text{ kJ/kg} = \mathbf{18.0 \text{ kW}}$$

(b) In the case of the reversible isothermal process, the steady-flow energy balance becomes

$$\dot{E}_{\text{in}} = \dot{E}_{\text{out}} \longrightarrow \dot{W}_{\text{in}} + \dot{m}h_1 - \dot{Q}_{\text{out}} = \dot{m}h_2 \longrightarrow \dot{W}_{\text{in}} = \dot{Q}_{\text{out}} + \dot{m}(h_2 - h_1)^{\phi_0} = \dot{Q}_{\text{out}}$$

since $h = h(T)$ for ideal gases, and thus the enthalpy change in this case is zero. Also, for a reversible isothermal process,

$$\dot{Q}_{\text{out}} = \dot{m}T(s_1 - s_2) = -\dot{m}T(s_2 - s_1)$$

where

$$s_2 - s_1 = (s_2^\circ - s_1^\circ)^{\phi_0} - R \ln \frac{P_2}{P_1} = -R \ln \frac{P_2}{P_1} = -(0.287 \text{ kJ/kg}\cdot\text{K}) \ln \frac{700 \text{ kPa}}{100 \text{ kPa}} = -0.5585 \text{ kJ/kg}\cdot\text{K}$$

Substituting, the power input for the reversible isothermal case becomes

$$\dot{W}_{\text{in}} = -(5/60 \text{ kg/s})(290 \text{ K})(-0.5585 \text{ kJ/kg}\cdot\text{K}) = \mathbf{13.5 \text{ kW}}$$

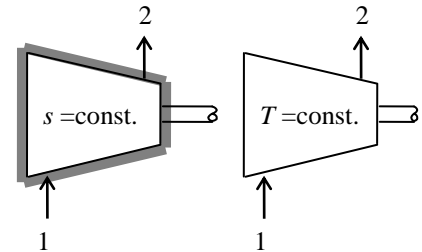

7-191 Air is compressed in a two-stage ideal compressor with intercooling. For a specified mass flow rate of air, the power input to the compressor is to be determined, and it is to be compared to the power input to a single-stage compressor.

Assumptions 1 The compressor operates steadily. **2** Kinetic and potential energies are negligible. **3** The compression process is reversible adiabatic, and thus isentropic. **4** Air is an ideal gas with constant specific heats at room temperature.

Properties The gas constant of air is $R = 0.287 \text{ kPa}\cdot\text{m}^3/\text{kg}\cdot\text{K}$ (Table A-1). The specific heat ratio of air is $k = 1.4$ (Table A-2).

Analysis The intermediate pressure between the two stages is

$$P_x = \sqrt{P_1 P_2} = \sqrt{(100 \text{ kPa})(625 \text{ kPa})} = 250 \text{ kPa}$$

The compressor work across each stage is the same, thus total compressor work is twice the compression work for a single stage:

$$\begin{aligned} w_{\text{comp, in}} &= (2)(w_{\text{comp, in, 1}}) = 2 \frac{kRT_1}{k-1} \left((P_x/P_1)^{(k-1)/k} - 1 \right) \\ &= 2 \frac{(1.4)(0.287 \text{ kJ/kg}\cdot\text{K})(300 \text{ K})}{1.4-1} \left(\left(\frac{250 \text{ kPa}}{100 \text{ kPa}} \right)^{0.4/1.4} - 1 \right) \\ &= 180.4 \text{ kJ/kg} \end{aligned}$$

and

$$\dot{W}_{\text{in}} = \dot{m}w_{\text{comp, in}} = (0.15 \text{ kg/s})(180.4 \text{ kJ/kg}) = \mathbf{27.1 \text{ kW}}$$

The work input to a single-stage compressor operating between the same pressure limits would be

$$w_{\text{comp, in}} = \frac{kRT_1}{k-1} \left((P_2/P_1)^{(k-1)/k} - 1 \right) = \frac{(1.4)(0.287 \text{ kJ/kg}\cdot\text{K})(300 \text{ K})}{1.4-1} \left(\left(\frac{625 \text{ kPa}}{100 \text{ kPa}} \right)^{0.4/1.4} - 1 \right) = 207.4 \text{ kJ/kg}$$

and

$$\dot{W}_{\text{in}} = \dot{m}w_{\text{comp, in}} = (0.15 \text{ kg/s})(207.4 \text{ kJ/kg}) = \mathbf{31.1 \text{ kW}}$$

Discussion Note that the power consumption of the compressor decreases significantly by using 2-stage compression with intercooling.

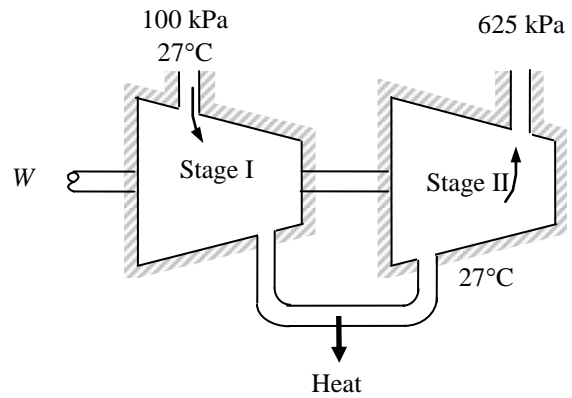

7-192 Steam expands in a two-stage adiabatic turbine from a specified state to specified pressure. Some steam is extracted at the end of the first stage. The power output of the turbine is to be determined for the cases of 100% and 88% isentropic efficiencies.

Assumptions 1 This is a steady-flow process since there is no change with time. **2** Kinetic and potential energy changes are negligible. **3** The turbine is adiabatic and thus heat transfer is negligible.

Properties From the steam tables (Tables A-4 through 6)

$$\begin{aligned} P_1 = 6 \text{ MPa} \left. \begin{array}{l} h_1 = 3423.1 \text{ kJ/kg} \\ T_1 = 500^\circ\text{C} \end{array} \right\} s_1 = 6.8826 \text{ kJ/kg} \cdot \text{K} \\ P_2 = 1.2 \text{ MPa} \left. \begin{array}{l} h_2 = 2962.8 \text{ kJ/kg} \\ s_2 = s_1 \end{array} \right\} \\ P_3 = 20 \text{ kPa} \left. \begin{array}{l} x_3 = \frac{s_3 - s_f}{s_{fg}} = \frac{6.8826 - 0.8320}{7.0752} = 0.8552 \\ s_3 = s_1 \end{array} \right\} h_3 = h_f + x_3 h_{fg} = 251.42 + (0.8552)(2357.5) = 2267.5 \text{ kJ/kg} \end{aligned}$$

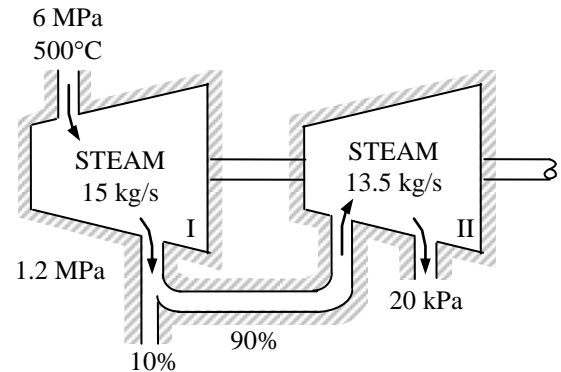

Analysis (a) The mass flow rate through the second stage is

$$\dot{m}_3 = 0.9\dot{m}_1 = (0.9)(15 \text{ kg/s}) = 13.5 \text{ kg/s}$$

We take the entire turbine, including the connection part between the two stages, as the system, which is a control volume since mass crosses the boundary. Noting that one fluid stream enters the turbine and two fluid streams leave, the energy balance for this steady-flow system can be expressed in the rate form as

$$\begin{aligned} \underbrace{\dot{E}_{\text{in}} - \dot{E}_{\text{out}}}_{\text{Rate of net energy transfer by heat, work, and mass}} &= \underbrace{\Delta \dot{E}_{\text{system}}^{\phi^0} (\text{steady})}_{\text{Rate of change in internal, kinetic, potential, etc. energies}} = 0 \\ \dot{E}_{\text{in}} &= \dot{E}_{\text{out}} \\ \dot{m}_1 h_1 &= (\dot{m}_1 - \dot{m}_3) h_2 + \dot{W}_{\text{out}} + \dot{m}_3 h_3 \\ \dot{W}_{\text{out}} &= \dot{m}_1 h_1 - (\dot{m}_1 - \dot{m}_3) h_2 - \dot{m}_3 h_3 \\ &= \dot{m}_1 (h_1 - h_2) + \dot{m}_3 (h_2 - h_3) \end{aligned}$$

Substituting, the power output of the turbine is

$$\dot{W}_{\text{out}} = (15 \text{ kg/s})(3423.1 - 2962.8) \text{ kJ/kg} + (13.5 \text{ kg})(2962.8 - 2267.5) \text{ kJ/kg} = \mathbf{16,290 \text{ kW}}$$

(b) If the turbine has an isentropic efficiency of 88%, then the power output becomes

$$\dot{W}_a = \eta_T \dot{W}_s = (0.88)(16,290 \text{ kW}) = \mathbf{14,335 \text{ kW}}$$

7-193 Refrigerant-134a is compressed by a 1.3-kW adiabatic compressor from a specified state to another specified state. The isentropic efficiency, the volume flow rate at the inlet, and the maximum flow rate at the compressor inlet are to be determined.

Assumptions 1 This is a steady-flow process since there is no change with time. **2** Kinetic and potential energy changes are negligible. **3** The device is adiabatic and thus heat transfer is negligible.

Properties From the R-134a tables (Table A-13)

$$P_1 = 140 \text{ kPa} \left\{ \begin{array}{l} \nu_1 = 0.14605 \text{ m}^3/\text{kg} \\ h_1 = 246.37 \text{ kJ/kg} \\ s_1 = 0.9724 \text{ kJ/kg} \cdot \text{K} \end{array} \right.$$

$$P_2 = 700 \text{ kPa} \left\{ \begin{array}{l} h_2 = 298.44 \text{ kJ/kg} \\ T_2 = 60^\circ\text{C} \end{array} \right.$$

$$P_2 = 700 \text{ kPa} \left\{ \begin{array}{l} h_{2s} = 281.18 \text{ kJ/kg} \\ s_{2s} = s_1 \end{array} \right.$$

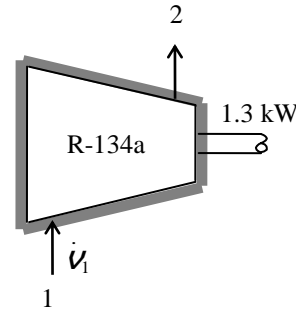

Analysis (a) The isentropic efficiency is determined from its definition,

$$\eta_C = \frac{h_{2s} - h_1}{h_{2a} - h_1} = \frac{281.18 - 246.37}{298.44 - 246.37} = 0.668 = \mathbf{66.8\%}$$

(b) There is only one inlet and one exit, and thus $\dot{m}_1 = \dot{m}_2 = \dot{m}$. We take the actual compressor as the system, which is a control volume. The energy balance for this steady-flow system can be expressed as

$$\underbrace{\dot{E}_{\text{in}} - \dot{E}_{\text{out}}}_{\text{Rate of net energy transfer by heat, work, and mass}} = \underbrace{\Delta \dot{E}_{\text{system}}}_{\text{Rate of change in internal, kinetic, potential, etc. energies}} \stackrel{\neq 0 \text{ (steady)}}{=} 0$$

$$\dot{E}_{\text{in}} = \dot{E}_{\text{out}}$$

$$\dot{W}_{\text{a,in}} + \dot{m}h_1 = \dot{m}h_2 \quad (\text{since } \dot{Q} \cong \Delta \text{ke} \cong \Delta \text{pe} \cong 0)$$

$$\dot{W}_{\text{a,in}} = \dot{m}(h_2 - h_1)$$

Then the mass and volume flow rates of the refrigerant are determined to be

$$\dot{m} = \frac{\dot{W}_{\text{a,in}}}{h_{2a} - h_1} = \frac{1.3 \text{ kJ/s}}{(298.44 - 246.37) \text{ kJ/kg}} = 0.02497 \text{ kg/s}$$

$$\dot{V}_1 = \dot{m} \nu_1 = (0.02497 \text{ kg/s})(0.14605 \text{ m}^3/\text{kg}) = 0.003647 \text{ m}^3/\text{s} = \mathbf{219 \text{ L/min}}$$

(c) The volume flow rate will be a maximum when the process is isentropic, and it is determined similarly from the steady-flow energy equation applied to the isentropic process. It gives

$$\dot{m}_{\text{max}} = \frac{\dot{W}_{\text{s,in}}}{h_{2s} - h_1} = \frac{1.3 \text{ kJ/s}}{(281.18 - 246.37) \text{ kJ/kg}} = 0.03735 \text{ kg/s}$$

$$\dot{V}_{1,\text{max}} = \dot{m}_{\text{max}} \nu_1 = (0.03735 \text{ kg/s})(0.14605 \text{ m}^3/\text{kg}) = 0.005455 \text{ m}^3/\text{s} = \mathbf{327 \text{ L/min}}$$

Discussion Note that the raising the isentropic efficiency of the compressor to 100% would increase the volumetric flow rate by about 50%.

7-194  An adiabatic compressor is powered by a direct-coupled steam turbine, which also drives a generator. The net power delivered to the generator and the rate of entropy generation are to be determined.

Assumptions **1** This is a steady-flow process since there is no change with time. **2** Kinetic and potential energy changes are negligible. **3** The devices are adiabatic and thus heat transfer is negligible. **4** Air is an ideal gas with variable specific heats.

Properties The gas constant of air is $R = 0.287 \text{ kJ/kg}\cdot\text{K}$ (Table A-1). From the steam tables (Tables A-4 through 6) and air table (Table A-17),

$$T_1 = 295 \text{ K} \longrightarrow h_1 = 295.17 \text{ kJ/kg}, s_1^\circ = 1.68515 \text{ kJ/kg}\cdot\text{K}$$

$$T_2 = 620 \text{ K} \longrightarrow h_2 = 628.07 \text{ kJ/kg}, s_2^\circ = 2.44356 \text{ kJ/kg}\cdot\text{K}$$

$$\left. \begin{array}{l} P_3 = 12.5 \text{ MPa} \\ T_3 = 500^\circ\text{C} \end{array} \right\} \begin{array}{l} h_3 = 3343.6 \text{ kJ/kg} \\ s_3 = 6.4651 \text{ kJ/kg}\cdot\text{K} \end{array}$$

$$\left. \begin{array}{l} P_4 = 10 \text{ kPa} \\ x_4 = 0.92 \end{array} \right\} \begin{array}{l} h_4 = h_f + x_4 h_{fg} = 191.81 + (0.92)(2392.1) = 2392.5 \text{ kJ/kg} \\ s_4 = s_f + x_4 s_{fg} = 0.6492 + (0.92)(7.4996) = 7.5489 \text{ kJ/kg}\cdot\text{K} \end{array}$$

Analysis There is only one inlet and one exit for either device, and thus $\dot{m}_{\text{in}} = \dot{m}_{\text{out}} = \dot{m}$. We take either the turbine or the compressor as the system, which is a control volume since mass crosses the boundary. The energy balance for either steady-flow system can be expressed in the rate form as

$$\underbrace{\dot{E}_{\text{in}} - \dot{E}_{\text{out}}}_{\text{Rate of net energy transfer by heat, work, and mass}} = \underbrace{\Delta \dot{E}_{\text{system}}}_{\text{Rate of change in internal, kinetic, potential, etc. energies}} \stackrel{\neq 0 \text{ (steady)}}{=} 0 \rightarrow \dot{E}_{\text{in}} = \dot{E}_{\text{out}}$$

For the turbine and the compressor it becomes

$$\text{Compressor: } \dot{W}_{\text{comp,in}} + \dot{m}_{\text{air}} h_1 = \dot{m}_{\text{air}} h_2 \rightarrow \dot{W}_{\text{comp,in}} = \dot{m}_{\text{air}} (h_2 - h_1)$$

$$\text{Turbine: } \dot{m}_{\text{steam}} h_3 = \dot{W}_{\text{turb,out}} + \dot{m}_{\text{steam}} h_4 \rightarrow \dot{W}_{\text{turb,out}} = \dot{m}_{\text{steam}} (h_3 - h_4)$$

Substituting,

$$\dot{W}_{\text{comp,in}} = (10 \text{ kg/s})(628.07 - 295.17) \text{ kJ/kg} = 3329 \text{ kW}$$

$$\dot{W}_{\text{turb,out}} = (25 \text{ kg/s})(3343.6 - 2392.5) \text{ kJ/kg} = 23,777 \text{ kW}$$

Therefore,

$$\dot{W}_{\text{net,out}} = \dot{W}_{\text{turb,out}} - \dot{W}_{\text{comp,in}} = 23,777 - 3329 = \mathbf{20,448 \text{ kW}}$$

Noting that the system is adiabatic, the total rate of entropy change (or generation) during this process is the sum of the entropy changes of both fluids,

$$\dot{S}_{\text{gen}} = \dot{m}_{\text{air}} (s_2 - s_1) + \dot{m}_{\text{steam}} (s_4 - s_3)$$

where

$$\dot{m}_{\text{air}} (s_2 - s_1) = \dot{m} \left(s_2^\circ - s_1^\circ - R \ln \frac{P_2}{P_1} \right) = (10 \text{ kg/s}) \left(2.44356 - 1.68515 - 0.287 \ln \frac{1000 \text{ kPa}}{98 \text{ kPa}} \right) \text{ kJ/kg}\cdot\text{K} = 0.92 \text{ kW/K}$$

$$\dot{m}_{\text{steam}} (s_4 - s_3) = (25 \text{ kg/s})(7.5489 - 6.4651) \text{ kJ/kg}\cdot\text{K} = 27.1 \text{ kW/K}$$

Substituting, the total rate of entropy generation is determined to be

$$\dot{S}_{\text{gen,total}} = \dot{S}_{\text{gen,comp}} + \dot{S}_{\text{gen,turb}} = 0.92 + 27.1 = \mathbf{28.02 \text{ kW/K}}$$

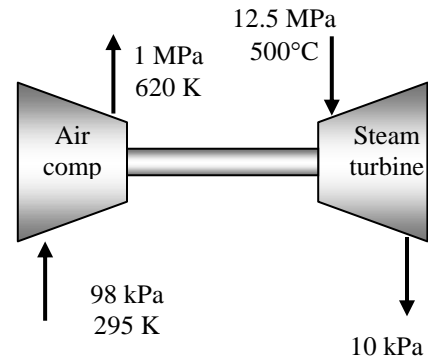



7-195 Problem 7-194 is reconsidered. The isentropic efficiencies for the compressor and turbine are to be determined, and then the effect of varying the compressor efficiency over the range 0.6 to 0.8 and the turbine efficiency over the range 0.7 to 0.95 on the net work for the cycle and the entropy generated for the process is to be investigated. The net work is to be plotted as a function of the compressor efficiency for turbine efficiencies of 0.7, 0.8, and 0.9.

Analysis The problem is solved using EES, and the results are tabulated and plotted below.

"Input Data"

m_dot_air = 10 [kg/s] "air compressor (air) data"
 T_air[1]=(295-273) "[C]" "We will input temperature in C"
 P_air[1]=98 [kPa]
 T_air[2]=(700-273) "[C]"
 P_air[2]=1000 [kPa]
 m_dot_st=25 [kg/s] "steam turbine (st) data"
 T_st[1]=500 [C]
 P_st[1]=12500 [kPa]
 P_st[2]=10 [kPa]
 x_st[2]=0.92 "quality"

"Compressor Analysis:"

"Conservation of mass for the compressor m_dot_air_in = m_dot_air_out = m_dot_air"

"Conservation of energy for the compressor is:"

E_dot_comp_in - E_dot_comp_out = DELTAE_dot_comp
 DELTAE_dot_comp = 0 "Steady flow requirement"
 E_dot_comp_in = m_dot_air*(enthalpy(air, T=T_air[1])) + W_dot_comp_in
 E_dot_comp_out = m_dot_air*(enthalpy(air, T=T_air[2]))

"Compressor adiabatic efficiency:"

Eta_comp = W_dot_comp_in_isen / W_dot_comp_in
 W_dot_comp_in_isen = m_dot_air*(enthalpy(air, T=T_air_isen[2]) - enthalpy(air, T=T_air[1]))
 s_air[1] = entropy(air, T=T_air[1], P=P_air[1])
 s_air[2] = entropy(air, T=T_air[2], P=P_air[2])
 s_air_isen[2] = entropy(air, T=T_air_isen[2], P=P_air[2])
 s_air_isen[2] = s_air[1]

"Turbine Analysis:"

"Conservation of mass for the turbine m_dot_st_in = m_dot_st_out = m_dot_st"

"Conservation of energy for the turbine is:"

E_dot_turb_in - E_dot_turb_out = DELTAE_dot_turb
 DELTAE_dot_turb = 0 "Steady flow requirement"
 E_dot_turb_in = m_dot_st*h_st[1]
 h_st[1] = enthalpy(steam, T=T_st[1], P=P_st[1])
 E_dot_turb_out = m_dot_st*h_st[2] + W_dot_turb_out
 h_st[2] = enthalpy(steam, P=P_st[2], x=x_st[2])

"Turbine adiabatic efficiency:"

Eta_turb = W_dot_turb_out / W_dot_turb_out_isen
 W_dot_turb_out_isen = m_dot_st*(h_st[1] - h_st_isen[2])
 s_st[1] = entropy(steam, T=T_st[1], P=P_st[1])
 h_st_isen[2] = enthalpy(steam, P=P_st[2], s=s_st[1])

"Note: When Eta_turb is specified as an independent variable in the Parametric Table, the iteration process may put the steam state 2 in the superheat region, where the quality is undefined. Thus, s_st[2], T_st[2] are calculated at P_st[2], h_st[2] and not P_st[2] and x_st[2]"

s_st[2] = entropy(steam, P=P_st[2], h=h_st[2])
 T_st[2] = temperature(steam, P=P_st[2], h=h_st[2])
 s_st_isen[2] = s_st[1]

"Net work done by the process:"

W_dot_net = W_dot_turb_out - W_dot_comp_in

"Entropy generation:"

"Since both the compressor and turbine are adiabatic, and thus there is no heat transfer to the surroundings, the entropy generation for the two steady flow devices becomes:"

S_dot_gen_comp = m_dot_air*(s_air[2] - s_air[1])

$$S_{\text{dot gen turb}} = m_{\text{dot st}}(s_{\text{st}[2]} - s_{\text{st}[1]})$$

$$S_{\text{dot gen total}} = S_{\text{dot gen comp}} + S_{\text{dot gen turb}}$$

"To generate the data for Plot Window 1, Comment out the line ' T_air[2]=(700-273) C' and select values for Eta_comp in the Parametric Table, then press F3 to solve the table. EES then solves for the unknown value of T_air[2] for each Eta_comp."

"To generate the data for Plot Window 2, Comment out the two lines ' x_st[2]=0.92 quality ' and ' h_st[2]=enthalpy(steam,P=P_st[2], x=x_st[2]) ' and select values for Eta_turb in the Parametric Table, then press F3 to solve the table. EES then solves for the h_st[2] for each Eta_turb."

W_{net} [kW]	$S_{\text{gen total}}$ [kW/K]	η_{turb}	η_{comp}
20124	27.59	0.75	0.6665
21745	22.51	0.8	0.6665
23365	17.44	0.85	0.6665
24985	12.36	0.9	0.6665
26606	7.281	0.95	0.6665

W_{net} [kW]	$S_{\text{gen total}}$ [kW/K]	η_{turb}	η_{comp}
19105	30	0.7327	0.6
19462	29.51	0.7327	0.65
19768	29.07	0.7327	0.7
20033	28.67	0.7327	0.75
20265	28.32	0.7327	0.8

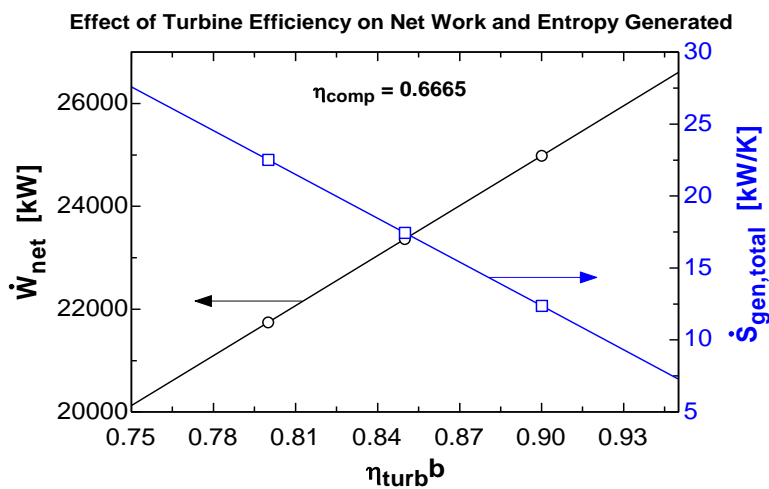
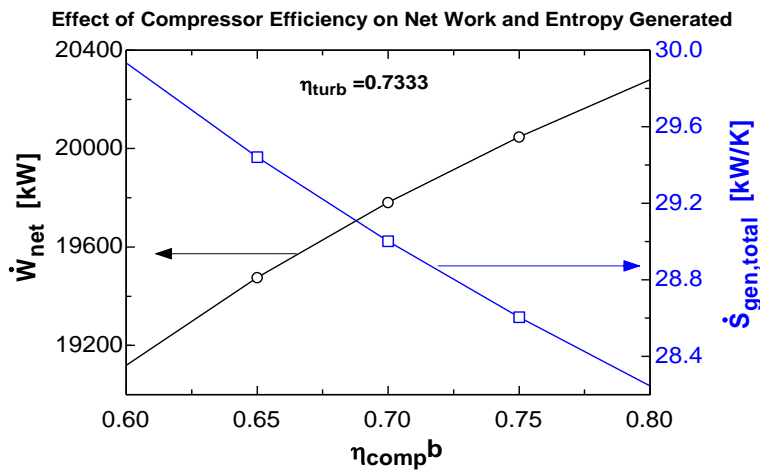

7-196 Air is expanded by an adiabatic turbine with an isentropic efficiency of 85%. The outlet temperature and the work produced are to be determined.

Assumptions 1 This is a steady-flow process since there is no change with time. **2** Kinetic and potential energy changes are negligible. **3** The device is adiabatic and thus heat transfer is negligible. **4** Air is an ideal gas with constant specific heats.

Properties The properties of air at the anticipated average temperature of 400 K are $c_p = 1.013 \text{ kJ/kg}\cdot^\circ\text{C}$ and $k = 1.395$ (Table A-2a).

Analysis We take the turbine as the system, which is a control volume since mass crosses the boundary. Noting that one fluid stream enters and leaves the turbine, the energy balance for this steady-flow system can be expressed in the rate form as

$$\underbrace{\dot{E}_{\text{in}} - \dot{E}_{\text{out}}}_{\text{Rate of net energy transfer by heat, work, and mass}} = \underbrace{\Delta \dot{E}_{\text{system}}}_{\text{Rate of change in internal, kinetic, potential, etc. energies}} \stackrel{\approx 0 \text{ (steady)}}{=} 0$$

$$\dot{E}_{\text{in}} = \dot{E}_{\text{out}}$$

$$\dot{m}h_1 = \dot{W}_{a,\text{out}} + \dot{m}h_2 \quad (\text{since } \dot{Q} \cong \Delta ke \cong \Delta pe \cong 0)$$

$$\dot{W}_{a,\text{out}} = \dot{m}(h_1 - h_2) = \dot{m}c_p(T_1 - T_2)$$

The isentropic exit temperature is

$$T_{2s} = T_1 \left(\frac{P_2}{P_1} \right)^{(k-1)/k} = (300 + 273 \text{ K}) \left(\frac{200 \text{ kPa}}{2200 \text{ kPa}} \right)^{0.395/1.395} = 290.6 \text{ K}$$

From the definition of the isentropic efficiency,

$$w_{a,\text{out}} = \eta_T w_{s,\text{out}} = \eta_T c_p (T_1 - T_{2s}) = (0.85)(1.013 \text{ kJ/kg}\cdot\text{K})(573 - 290.6)\text{K} = \mathbf{243.2 \text{ kJ/kg}}$$

The actual exit temperature is then

$$w_{a,\text{out}} = c_p (T_1 - T_{2a}) \longrightarrow T_{2a} = T_1 - \frac{w_{a,\text{out}}}{c_p} = T_1 - \frac{w_{a,\text{out}}}{c_p} = 573 \text{ K} - \frac{243.2 \text{ kJ/kg}}{1.013 \text{ kJ/kg}\cdot\text{K}} = \mathbf{333 \text{ K}}$$

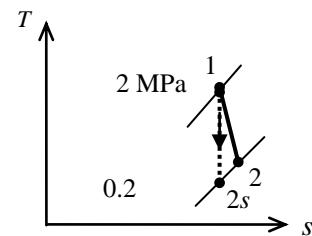
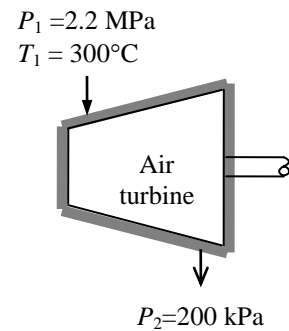

7-197 Air is expanded by an adiabatic turbine with an isentropic efficiency of 85%. The outlet temperature, the work produced, and the entropy generation are to be determined.

Assumptions 1 This is a steady-flow process since there is no change with time. **2** Kinetic and potential energy changes are negligible. **3** The device is adiabatic and thus heat transfer is negligible. **4** Air is an ideal gas with constant specific heats.

Properties The properties of air at the anticipated average temperature of 400 K are $c_p = 1.013 \text{ kJ/kg}\cdot^\circ\text{C}$ and $k = 1.395$ (Table A-2b). Also, $R = 0.287 \text{ kJ/kg}\cdot\text{K}$ (Table A-2a).

Analysis We take the turbine as the system, which is a control volume since mass crosses the boundary. Noting that one fluid stream enters and leaves the turbine, the energy balance for this steady-flow system can be expressed in the rate form as

$$\underbrace{\dot{E}_{\text{in}} - \dot{E}_{\text{out}}}_{\text{Rate of net energy transfer by heat, work, and mass}} = \underbrace{\Delta\dot{E}_{\text{system}}}_{\text{Rate of change in internal, kinetic, potential, etc. energies}} \stackrel{\approx 0 \text{ (steady)}}{=} 0$$

$$\dot{E}_{\text{in}} = \dot{E}_{\text{out}}$$

$$\dot{m}h_1 = \dot{W}_{a,\text{out}} + \dot{m}h_2 \quad (\text{since } \dot{Q} \cong \Delta\text{ke} \cong \Delta\text{pe} \cong 0)$$

$$\dot{W}_{a,\text{out}} = \dot{m}(h_1 - h_2) = \dot{m}c_p(T_1 - T_2)$$

The isentropic exit temperature is

$$T_{2s} = T_1 \left(\frac{P_{2s}}{P_1} \right)^{(k-1)/k} = (400 + 273 \text{ K}) \left(\frac{150 \text{ kPa}}{2800 \text{ kPa}} \right)^{0.395/1.395} = 293.8 \text{ K}$$

From the definition of the isentropic efficiency,

$$w_{a,\text{out}} = \eta_T w_{s,\text{out}} = \eta_T c_p (T_1 - T_{2s}) = (0.90)(1.013 \text{ kJ/kg}\cdot\text{K})(673 - 293.8)\text{K} = \mathbf{345.7 \text{ kJ/kg}}$$

The actual exit temperature is then

$$w_{a,\text{out}} = c_p (T_1 - T_{2a}) \longrightarrow T_{2a} = T_1 - \frac{w_{a,\text{out}}}{c_p} = T_1 - \frac{w_{a,\text{out}}}{c_p} = 673 \text{ K} - \frac{345.7 \text{ kJ/kg}}{1.013 \text{ kJ/kg}\cdot\text{K}} = \mathbf{331.8 \text{ K}}$$

The rate of entropy generation in the turbine is determined by applying the rate form of the entropy balance on the turbine:

$$\underbrace{\dot{S}_{\text{in}} - \dot{S}_{\text{out}}}_{\text{Rate of net entropy transfer by heat and mass}} + \underbrace{\dot{S}_{\text{gen}}}_{\text{Rate of entropy generation}} = \underbrace{\Delta\dot{S}_{\text{system}}}_{\text{Rate of change of entropy}} \stackrel{\approx 0 \text{ (steady)}}{=} 0$$

$$\dot{m}_1 s_1 - \dot{m}_2 s_2 + \dot{S}_{\text{gen}} = 0 \quad (\text{since } \dot{Q} = 0)$$

$$\dot{S}_{\text{gen}} = \dot{m}(s_2 - s_1)$$

$$s_{\text{gen}} = s_2 - s_1$$

Then, from the entropy change relation of an ideal gas,

$$s_{\text{gen}} = s_2 - s_1 = c_p \ln \frac{T_2}{T_1} - R \ln \frac{P_2}{P_1}$$

$$= (1.013 \text{ kJ/kg}\cdot\text{K}) \ln \frac{331.8 \text{ K}}{673 \text{ K}} - (0.287 \text{ kJ/kg}\cdot\text{K}) \ln \frac{150 \text{ kPa}}{2800 \text{ kPa}}$$

$$= \mathbf{0.123 \text{ kJ/kg}\cdot\text{K}}$$

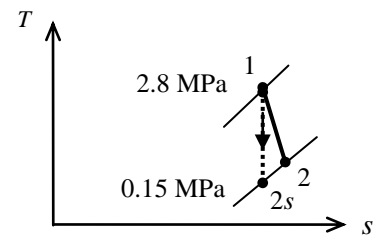
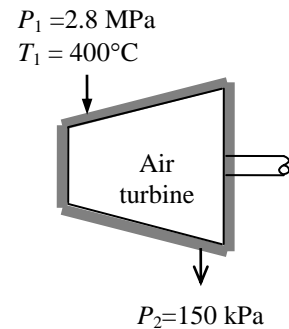

7-198 A throttle valve is placed in the steam line of an adiabatic turbine. The work output is to be determined with and without throttle valve cases.

Assumptions 1 This is a steady-flow process since there is no change with time. **2** Kinetic and potential energy changes are negligible. **3** The device is adiabatic and thus heat transfer is negligible.

Analysis There is only one inlet and one exit, and thus $\dot{m}_1 = \dot{m}_2 = \dot{m}$. We take the actual turbine as the system, which is a control volume since mass crosses the boundary. The energy balance for this steady-flow system can be expressed in the rate form as

$$\underbrace{\dot{E}_{\text{in}} - \dot{E}_{\text{out}}}_{\text{Rate of net energy transfer by heat, work, and mass}} = \underbrace{\dot{\Delta E}_{\text{system}}}_{\text{Rate of change in internal, kinetic, potential, etc. energies}} \stackrel{\neq 0 \text{ (steady)}}{=} 0$$

$$\dot{E}_{\text{in}} = \dot{E}_{\text{out}}$$

$$\dot{m}h_1 = \dot{W}_{a,\text{out}} + \dot{m}h_2 \quad (\text{since } \dot{Q} \cong \Delta ke \cong \Delta pe \cong 0)$$

$$\dot{W}_{\text{out}} = \dot{m}(h_1 - h_2)$$

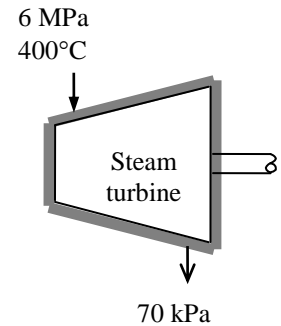

When the valve is fully open, from the steam tables (Tables A-4 through A-6),

$$\left. \begin{array}{l} P_1 = 6 \text{ MPa} \\ T_1 = 400^\circ\text{C} \end{array} \right\} \begin{array}{l} h_1 = 3178.3 \text{ kJ/kg} \\ s_1 = 6.5432 \text{ kJ/kg} \cdot \text{K} \end{array}$$

$$\left. \begin{array}{l} P_3 = 70 \text{ kPa} \\ s_3 = s_1 = 6.5432 \text{ kJ/kg} \cdot \text{K} \end{array} \right\} \begin{array}{l} x_3 = 0.8511 \\ h_3 = 2319.6 \text{ kJ/kg} \end{array}$$

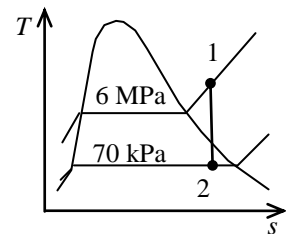

Then,

$$w_{\text{out}} = h_1 - h_3 = 3178.3 - 2319.6 = \mathbf{858.6 \text{ kJ/kg}}$$

The flow through the throttle valve is isenthalpic (constant enthalpy). When the valve is partially closed, from the steam tables (Tables A-4 through A-6),

$$\left. \begin{array}{l} P_2 = 3 \text{ MPa} \\ h_2 = h_1 = 3178.3 \text{ kJ/kg} \end{array} \right\} s_2 = 6.8427 \text{ kJ/kg} \cdot \text{K}$$

$$\left. \begin{array}{l} P_3 = 70 \text{ kPa} \\ s_3 = s_2 = 6.8427 \text{ kJ/kg} \cdot \text{K} \end{array} \right\} \begin{array}{l} x_3 = 0.8988 \\ h_3 = 2428.4 \text{ kJ/kg} \end{array}$$

Then,

$$w_{\text{out}} = h_2 - h_3 = 3178.3 - 2428.4 = \mathbf{749.9 \text{ kJ/kg}}$$

7-199 Two rigid tanks that contain water at different states are connected by a valve. The valve is opened and steam flows from tank A to tank B until the pressure in tank A drops to a specified value. Tank B loses heat to the surroundings. The final temperature in each tank and the entropy generated during this process are to be determined.

Assumptions 1 Tank A is insulated, and thus heat transfer is negligible. **2** The water that remains in tank A undergoes a reversible adiabatic process. **3** The thermal energy stored in the tanks themselves is negligible. **4** The system is stationary and thus kinetic and potential energy changes are negligible. **5** There are no work interactions.

Analysis (a) The steam in tank A undergoes a reversible, adiabatic process, and thus $s_2 = s_1$. From the steam tables (Tables A-4 through A-6),

Tank A:

$$P_1 = 400 \text{ kPa} \quad \left\{ \begin{array}{l} v_{1,A} = v_f + x_1 v_{fg} = 0.001084 + (0.6)(0.46242 - 0.001084) = 0.27788 \text{ m}^3/\text{kg} \\ u_{1,A} = u_f + x_1 u_{fg} = 604.22 + (0.6)(1948.9) = 1773.6 \text{ kJ/kg} \\ s_{1,A} = s_f + x_1 s_{fg} = 1.7765 + (0.6)(5.1191) = 4.8479 \text{ kJ/kg} \cdot \text{K} \end{array} \right.$$

$$T_{2,A} = T_{\text{sat}@200 \text{ kPa}} = \mathbf{120.2^\circ\text{C}}$$

$$P_2 = 200 \text{ kPa} \quad \left\{ \begin{array}{l} x_{2,A} = \frac{s_{2,A} - s_f}{s_{fg}} = \frac{4.8479 - 1.5302}{5.59680} = 0.5928 \\ v_{2,A} = v_f + x_{2,A} v_{fg} = 0.001061 + (0.5928)(0.8858 - 0.001061) = 0.52552 \text{ m}^3/\text{kg} \\ u_{2,A} = u_f + x_{2,A} u_{fg} = 504.50 + (0.5928)(2024.6 \text{ kJ/kg}) = 1704.7 \text{ kJ/kg} \end{array} \right.$$

Tank B:

$$P_1 = 200 \text{ kPa} \quad \left\{ \begin{array}{l} v_{1,B} = 1.1989 \text{ m}^3/\text{kg} \\ u_{1,B} = 2731.4 \text{ kJ/kg} \\ s_{1,B} = 7.7100 \text{ kJ/kg} \cdot \text{K} \end{array} \right.$$

The initial and the final masses in tank A are

$$m_{1,A} = \frac{V_A}{v_{1,A}} = \frac{0.3 \text{ m}^3}{0.27788 \text{ m}^3/\text{kg}} = 1.080 \text{ kg}$$

and

$$m_{2,A} = \frac{V_A}{v_{2,A}} = \frac{0.3 \text{ m}^3}{0.52552 \text{ m}^3/\text{kg}} = 0.5709 \text{ kg}$$

Thus, $1.080 - 0.5709 = 0.5091 \text{ kg}$ of mass flows into tank B. Then,

$$m_{2,B} = m_{1,B} + 0.5091 = 2 + 0.5091 = 2.509 \text{ kg}$$

The final specific volume of steam in tank B is determined from

$$v_{2,B} = \frac{V_B}{m_{2,B}} = \frac{(m_1 v_1)_B}{m_{2,B}} = \frac{(2 \text{ kg})(1.1989 \text{ m}^3/\text{kg})}{2.509 \text{ kg}} = 0.9558 \text{ m}^3/\text{kg}$$

We take the entire contents of both tanks as the system, which is a closed system. The energy balance for this stationary closed system can be expressed as

$$\underbrace{E_{\text{in}} - E_{\text{out}}}_{\text{Net energy transfer by heat, work, and mass}} = \underbrace{\Delta E_{\text{system}}}_{\text{Change in internal, kinetic, potential, etc. energies}}$$

$$-Q_{\text{out}} = \Delta U = (\Delta U)_A + (\Delta U)_B \quad (\text{since } W = \text{KE} = \text{PE} = 0)$$

$$-Q_{\text{out}} = (m_2 u_2 - m_1 u_1)_A + (m_2 u_2 - m_1 u_1)_B$$

Substituting,

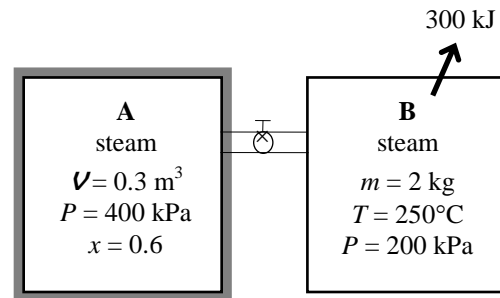

$$-300 = \{(0.5709)(1704.7) - (1.080)(1773.6)\} + \{(2.509)u_{2,B} - (2)(2731.4)\}$$

$$u_{2,B} = 2433.3 \text{ kJ/kg}$$

Thus,

$$\left. \begin{aligned} v_{2,B} &= 0.9558 \text{ m}^3/\text{kg} \\ u_{2,B} &= 2433.3 \text{ kJ/kg} \end{aligned} \right\} \begin{aligned} T_{2,B} &= \mathbf{116.1^\circ\text{C}} \\ s_{2,B} &= 6.9156 \text{ kJ/kg}\cdot\text{K} \end{aligned}$$

(b) The total entropy generation during this process is determined by applying the entropy balance on an *extended system* that includes both tanks and their immediate surroundings so that the boundary temperature of the extended system is the temperature of the surroundings at all times. It gives

$$\underbrace{S_{\text{in}} - S_{\text{out}}}_{\substack{\text{Net entropy transfer} \\ \text{by heat and mass}}} + \underbrace{S_{\text{gen}}}_{\substack{\text{Entropy} \\ \text{generation}}} = \underbrace{\Delta S_{\text{system}}}_{\substack{\text{Change} \\ \text{in entropy}}}$$

$$-\frac{Q_{\text{out}}}{T_{\text{b,surr}}} + S_{\text{gen}} = \Delta S_A + \Delta S_B$$

Rearranging and substituting, the total entropy generated during this process is determined to be

$$S_{\text{gen}} = \Delta S_A + \Delta S_B + \frac{Q_{\text{out}}}{T_{\text{b,surr}}} = (m_2 s_2 - m_1 s_1)_A + (m_2 s_2 - m_1 s_1)_B + \frac{Q_{\text{out}}}{T_{\text{b,surr}}}$$

$$= \{(0.5709)(4.8479) - (1.080)(4.8479)\} + \{(2.509)(6.9156) - (2)(7.7100)\} + \frac{300 \text{ kJ}}{290 \text{ K}}$$

$$= \mathbf{0.498 \text{ kJ/K}}$$

7-200 An electric resistance heater is immersed in water. The time it will take for the electric heater to raise the water temperature to a specified temperature and the entropy generated during this process are to be determined.

Assumptions **1** Water is an incompressible substance with constant specific heats. **2** The energy stored in the container itself and the heater is negligible. **3** Heat loss from the container is negligible.

Properties The specific heat of water at room temperature is $c = 4.18 \text{ kJ/kg}\cdot^\circ\text{C}$ (Table A-3).

Analysis Taking the water in the container as the system, which is a closed system, the energy balance can be expressed as

$$\underbrace{E_{\text{in}} - E_{\text{out}}}_{\substack{\text{Net energy transfer} \\ \text{by heat, work, and mass}}} = \underbrace{\Delta E_{\text{system}}}_{\substack{\text{Change in internal, kinetic,} \\ \text{potential, etc. energies}}}$$

$$W_{\text{e,in}} = (\Delta U)_{\text{water}}$$

$$\dot{W}_{\text{e,in}} \Delta t = mc(T_2 - T_1)_{\text{water}}$$

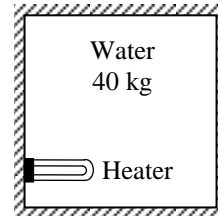

Substituting,

$$(1200 \text{ J/s})\Delta t = (40 \text{ kg})(4180 \text{ J/kg}\cdot^\circ\text{C})(50 - 20)^\circ\text{C}$$

Solving for Δt gives

$$\Delta t = 4180 \text{ s} = 69.7 \text{ min} = 1.16 \text{ h}$$

Again we take the water in the tank to be the system. Noting that no heat or mass crosses the boundaries of this system and the energy and entropy contents of the heater are negligible, the entropy balance for it can be expressed as

$$\underbrace{S_{\text{in}} - S_{\text{out}}}_{\substack{\text{Net entropy transfer} \\ \text{by heat and mass}}} + \underbrace{S_{\text{gen}}}_{\substack{\text{Entropy} \\ \text{generation}}} = \underbrace{\Delta S_{\text{system}}}_{\substack{\text{Change} \\ \text{in entropy}}}$$

$$0 + S_{\text{gen}} = \Delta S_{\text{water}}$$

Therefore, the entropy generated during this process is

$$S_{\text{gen}} = \Delta S_{\text{water}} = mc \ln \frac{T_2}{T_1} = (40 \text{ kg})(4.18 \text{ kJ/kg}\cdot\text{K}) \ln \frac{323 \text{ K}}{293 \text{ K}} = 16.3 \text{ kJ/K}$$

7-201E A rigid tank initially contains saturated R-134a vapor. The tank is connected to a supply line, and is charged until the tank contains saturated liquid at a specified pressure. The mass of R-134a that entered the tank, the heat transfer with the surroundings at 100°F, and the entropy generated during this process are to be determined.

Assumptions 1 This is an unsteady process since the conditions within the device are changing during the process, but it can be analyzed as a uniform-flow process since the state of fluid at the inlet remains constant. **2** Kinetic and potential energies are negligible. **3** There are no work interactions involved. **4** The direction of heat transfer is to the tank (will be verified).

Properties The properties of R-134a are (Tables A-11 through A-13)

$$\begin{aligned}
 P_1 = 60 \text{ psia} \left. \begin{array}{l} \nu_1 = \nu_{g@60 \text{ psia}} = 0.79462 \text{ ft}^3/\text{lbm} \\ u_1 = u_{g@60 \text{ psia}} = 101.31 \text{ Btu/lbm} \\ s_1 = s_{g@60 \text{ psia}} = 0.22132 \text{ Btu/lbm} \cdot \text{R} \end{array} \right\} \text{ sat. vapor} \\
 P_2 = 100 \text{ psia} \left. \begin{array}{l} \nu_2 = \nu_{f@100 \text{ psia}} = 0.01332 \text{ ft}^3/\text{lbm} \\ u_2 = u_{f@100 \text{ psia}} = 37.62 \text{ Btu/lbm} \\ s_2 = s_{f@100 \text{ psia}} = 0.07879 \text{ Btu/lbm} \cdot \text{R} \end{array} \right\} \text{ sat. liquid} \\
 P_i = 140 \text{ psia} \left. \begin{array}{l} h_i \cong h_{f@80^\circ\text{F}} = 38.17 \text{ Btu/lbm} \\ s_i \cong s_{f@80^\circ\text{F}} = 0.07934 \text{ Btu/lbm} \cdot \text{R} \end{array} \right\} T_i = 80^\circ\text{F}
 \end{aligned}$$

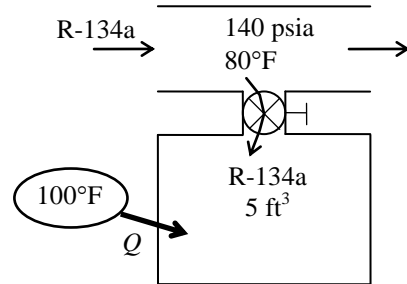

Analysis (a) We take the tank as the system, which is a control volume since mass crosses the boundary. Noting that the energies of flowing and nonflowing fluids are represented by enthalpy h and internal energy u , respectively, the mass and energy balances for this uniform-flow system can be expressed as

$$\text{Mass balance: } m_{\text{in}} - m_{\text{out}} = \Delta m_{\text{system}} \rightarrow m_i = m_2 - m_1$$

Energy balance:

$$\underbrace{E_{\text{in}} - E_{\text{out}}}_{\substack{\text{Net energy transfer} \\ \text{by heat, work, and mass}}} = \underbrace{\Delta E_{\text{system}}}_{\substack{\text{Change in internal, kinetic,} \\ \text{potential, etc. energies}}}$$

$$Q_{\text{in}} + m_i h_i = m_2 u_2 - m_1 u_1 \quad (\text{since } W \cong \text{ke} \cong \text{pe} \cong 0)$$

The initial and the final masses in the tank are

$$m_1 = \frac{\nu}{\nu_1} = \frac{5 \text{ ft}^3}{0.79462 \text{ ft}^3/\text{lbm}} = 6.292 \text{ lbm} \qquad m_2 = \frac{\nu}{\nu_2} = \frac{5 \text{ ft}^3}{0.01332 \text{ ft}^3/\text{lbm}} = 375.30 \text{ lbm}$$

Then from the mass balance,

$$m_i = m_2 - m_1 = 375.30 - 6.292 = \mathbf{369.0 \text{ lbm}}$$

(b) The heat transfer during this process is determined from the energy balance to be

$$\begin{aligned}
 Q_{\text{in}} &= -m_i h_i + m_2 u_2 - m_1 u_1 \\
 &= -(369.0 \text{ lbm})(38.17 \text{ Btu/lbm}) + (375.30 \text{ lbm})(37.62 \text{ Btu/lbm}) - (6.292 \text{ lbm})(101.31 \text{ Btu/lbm}) \\
 &= \mathbf{-602.5 \text{ Btu}}
 \end{aligned}$$

The negative sign indicates that heat is lost from the tank in the amount of 602.5 Btu.

(c) The entropy generated during this process is determined by applying the entropy balance on an *extended system* that includes the tank and its immediate surroundings so that the boundary temperature of the extended system is the temperature of the surroundings at all times. The entropy balance for it can be expressed as

$$\underbrace{S_{\text{in}} - S_{\text{out}}}_{\substack{\text{Net entropy transfer} \\ \text{by heat and mass}}} + \underbrace{S_{\text{gen}}}_{\substack{\text{Entropy} \\ \text{generation}}} = \underbrace{\Delta S_{\text{system}}}_{\substack{\text{Change} \\ \text{in entropy}}} \longrightarrow \frac{Q_{\text{in}}}{T_{\text{b,in}}} + m_i s_i + S_{\text{gen}} = \Delta S_{\text{tank}} = m_2 s_2 - m_1 s_1$$

Therefore, the total entropy generated during this process is

$$\begin{aligned}
 S_{\text{gen}} &= -m_i s_i + (m_2 s_2 - m_1 s_1) - \frac{Q_{\text{in}}}{T_{\text{b,in}}} \\
 &= -(369.0)(0.07934) + (375.30)(0.07879) - (6.292)(0.22132) - \frac{(-602.5 \text{ Btu})}{530 \text{ R}} = \mathbf{0.0369 \text{ Btu/R}}
 \end{aligned}$$

7-202 The heating of a passive solar house at night is to be assisted by solar heated water. The length of time that the electric heating system would run that night and the amount of entropy generated that night are to be determined.

Assumptions 1 Water is an incompressible substance with constant specific heats. **2** The energy stored in the glass containers themselves is negligible relative to the energy stored in water. **3** The house is maintained at 22°C at all times.

Properties The density and specific heat of water at room temperature are $\rho = 997 \text{ kg/m}^3$ and $c = 4.18 \text{ kJ/kg}\cdot^\circ\text{C}$ (Table A-3).

Analysis The total mass of water is

$$m_w = \rho V = (0.997 \text{ kg/L})(50 \times 20 \text{ L}) = 997 \text{ kg}$$

Taking the contents of the house, including the water as our system, the energy balance relation can be written as

$$\begin{aligned} \underbrace{E_{\text{in}} - E_{\text{out}}}_{\substack{\text{Net energy transfer} \\ \text{by heat, work, and mass}}} &= \underbrace{\Delta E_{\text{system}}}_{\substack{\text{Change in internal, kinetic,} \\ \text{potential, etc. energies}}} \\ W_{\text{e,in}} - Q_{\text{out}} &= \Delta U = (\Delta U)_{\text{water}} + (\Delta U)_{\text{air}} \\ &= (\Delta U)_{\text{water}} \\ &= mc(T_2 - T_1)_{\text{water}} \end{aligned}$$

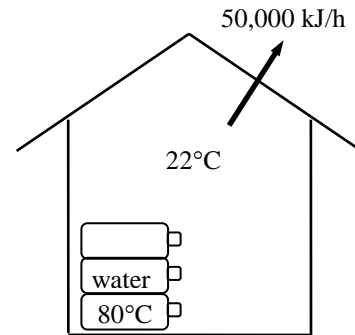

or,

$$\dot{W}_{\text{e,in}} \Delta t - Q_{\text{out}} = [mc(T_2 - T_1)]_{\text{water}}$$

Substituting,

$$(15 \text{ kJ/s})\Delta t - (50,000 \text{ kJ/h})(10 \text{ h}) = (997 \text{ kg})(4.18 \text{ kJ/kg}\cdot^\circ\text{C})(22 - 80)^\circ\text{C}$$

It gives

$$\Delta t = 17,219 \text{ s} = \mathbf{4.78 \text{ h}}$$

We take the house as the system, which is a closed system. The entropy generated during this process is determined by applying the entropy balance on an *extended system* that includes the house and its immediate surroundings so that the boundary temperature of the extended system is the temperature of the surroundings at all times. The entropy balance for the extended system can be expressed as

$$\begin{aligned} \underbrace{S_{\text{in}} - S_{\text{out}}}_{\substack{\text{Net entropy transfer} \\ \text{by heat and mass}}} + \underbrace{S_{\text{gen}}}_{\substack{\text{Entropy} \\ \text{generation}}} &= \underbrace{\Delta S_{\text{system}}}_{\substack{\text{Change} \\ \text{in entropy}}} \\ -\frac{Q_{\text{out}}}{T_{\text{b,out}}} + S_{\text{gen}} &= \Delta S_{\text{water}} + \Delta S_{\text{air}} \stackrel{\neq 0}{=} \Delta S_{\text{water}} \end{aligned}$$

since the state of air in the house remains unchanged. Then the entropy generated during the 10-h period that night is

$$\begin{aligned} S_{\text{gen}} &= \Delta S_{\text{water}} + \frac{Q_{\text{out}}}{T_{\text{b,out}}} = \left(mc \ln \frac{T_2}{T_1} \right)_{\text{water}} + \frac{Q_{\text{out}}}{T_{\text{surr}}} \\ &= (997 \text{ kg})(4.18 \text{ kJ/kg}\cdot\text{K}) \ln \frac{295 \text{ K}}{353 \text{ K}} + \frac{500,000 \text{ kJ}}{276 \text{ K}} \\ &= -748 + 1811 = \mathbf{1063 \text{ kJ/K}} \end{aligned}$$

7-203E A steel container that is filled with hot water is allowed to cool to the ambient temperature. The total entropy generated during this process is to be determined.

Assumptions **1** Both the water and the steel tank are incompressible substances with constant specific heats at room temperature. **2** The system is stationary and thus the kinetic and potential energy changes are zero. **3** Specific heat of iron can be used for steel. **4** There are no work interactions involved.

Properties The specific heats of water and the iron at room temperature are $c_{p, \text{water}} = 1.00 \text{ Btu/lbm}\cdot^\circ\text{F}$ and $C_{p, \text{iron}} = 0.107 \text{ Btu/lbm}\cdot^\circ\text{C}$. The density of water at room temperature is 62.1 lbm/ft^3 (Table A-3E).

Analysis The mass of the water is

$$m_{\text{water}} = \rho \mathcal{V} = (62.1 \text{ lbm/ft}^3)(15 \text{ ft}^3) = 931.5 \text{ lbm}$$

We take the steel container and the water in it as the system, which is a closed system. The energy balance on the system can be expressed as

$$\begin{aligned} \underbrace{E_{\text{in}} - E_{\text{out}}}_{\substack{\text{Net energy transfer} \\ \text{by heat, work, and mass}}} &= \underbrace{\Delta E_{\text{system}}}_{\substack{\text{Change in internal, kinetic,} \\ \text{potential, etc. energies}}} \\ -Q_{\text{out}} = \Delta U &= \Delta U_{\text{container}} + \Delta U_{\text{water}} \\ &= [mc(T_2 - T_1)]_{\text{container}} + [mc(T_2 - T_1)]_{\text{water}} \end{aligned}$$

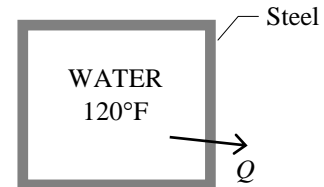

Substituting, the heat loss to the surrounding air is determined to be

$$\begin{aligned} Q_{\text{out}} &= [mc(T_1 - T_2)]_{\text{container}} + [mc(T_1 - T_2)]_{\text{water}} \\ &= (75 \text{ lbm})(0.107 \text{ Btu/lbm}\cdot^\circ\text{F})(120 - 70)^\circ\text{F} + (931.5 \text{ lbm})(1.00 \text{ Btu/lbm}\cdot^\circ\text{F})(120 - 70)^\circ\text{F} \\ &= 46,976 \text{ Btu} \end{aligned}$$

We again take the container and the water in it as the system. The entropy generated during this process is determined by applying the entropy balance on an *extended system* that includes the container and its immediate surroundings so that the boundary temperature of the extended system is the temperature of the surrounding air at all times. The entropy balance for the extended system can be expressed as

$$\begin{aligned} \underbrace{S_{\text{in}} - S_{\text{out}}}_{\substack{\text{Net entropy transfer} \\ \text{by heat and mass}}} + \underbrace{S_{\text{gen}}}_{\substack{\text{Entropy} \\ \text{generation}}} &= \underbrace{\Delta S_{\text{system}}}_{\substack{\text{Change} \\ \text{in entropy}}} \\ -\frac{Q_{\text{out}}}{T_{\text{b,out}}} + S_{\text{gen}} &= \Delta S_{\text{container}} + \Delta S_{\text{water}} \end{aligned}$$

where

$$\begin{aligned} \Delta S_{\text{container}} &= mc_{\text{avg}} \ln \frac{T_2}{T_1} = (75 \text{ lbm})(0.107 \text{ Btu/lbm}\cdot\text{R}) \ln \frac{530 \text{ R}}{580 \text{ R}} = -0.72 \text{ Btu/R} \\ \Delta S_{\text{water}} &= mc_{\text{avg}} \ln \frac{T_2}{T_1} = (931.5 \text{ lbm})(1.00 \text{ Btu/lbm}\cdot\text{R}) \ln \frac{530 \text{ R}}{580 \text{ R}} = -83.98 \text{ Btu/R} \end{aligned}$$

Therefore, the total entropy generated during this process is

$$S_{\text{gen}} = \Delta S_{\text{container}} + \Delta S_{\text{water}} + \frac{Q_{\text{out}}}{T_{\text{b,out}}} = -0.72 - 83.98 + \frac{46,976 \text{ Btu}}{70 + 460 \text{ R}} = \mathbf{3.93 \text{ Btu/R}}$$

7-204 A 1-ton (1000 kg) of water is to be cooled in a tank by pouring ice into it. The final equilibrium temperature in the tank and the entropy generation are to be determined.

Assumptions 1 Thermal properties of the ice and water are constant. **2** Heat transfer to the water tank is negligible. **3** There is no stirring by hand or a mechanical device (it will add energy).

Properties The specific heat of water at room temperature is $c = 4.18 \text{ kJ/kg}\cdot^\circ\text{C}$, and the specific heat of ice at about 0°C is $c = 2.11 \text{ kJ/kg}\cdot^\circ\text{C}$ (Table A-3). The melting temperature and the heat of fusion of ice at 1 atm are 0°C and 333.7 kJ/kg .

Analysis (a) We take the ice and the water as the system, and disregard any heat transfer between the system and the surroundings.

Then the energy balance for this process can be written as

$$\underbrace{E_{\text{in}} - E_{\text{out}}}_{\substack{\text{Net energy transfer} \\ \text{by heat, work, and mass}}} = \underbrace{\Delta E_{\text{system}}}_{\substack{\text{Change in internal, kinetic,} \\ \text{potential, etc. energies}}}$$

$$0 = \Delta U$$

$$0 = \Delta U_{\text{ice}} + \Delta U_{\text{water}}$$

$$[mc(0^\circ\text{C} - T_1)_{\text{solid}} + mh_{\text{if}} + mc(T_2 - 0^\circ\text{C})_{\text{liquid}}]_{\text{ice}} + [mc(T_2 - T_1)]_{\text{water}} = 0$$

Substituting,

$$(80 \text{ kg})\{(2.11 \text{ kJ/kg}\cdot^\circ\text{C})[0 - (-5)]^\circ\text{C} + 333.7 \text{ kJ/kg} + (4.18 \text{ kJ/kg}\cdot^\circ\text{C})(T_2 - 0)^\circ\text{C}\} \\ + (1000 \text{ kg})(4.18 \text{ kJ/kg}\cdot^\circ\text{C})(T_2 - 20)^\circ\text{C} = 0$$

It gives

$$T_2 = \mathbf{12.42^\circ\text{C}}$$

which is the final equilibrium temperature in the tank.

(b) We take the ice and the water as our system, which is a closed system. Considering that the tank is well-insulated and thus there is no heat transfer, the entropy balance for this closed system can be expressed as

$$\underbrace{S_{\text{in}} - S_{\text{out}}}_{\substack{\text{Net entropy transfer} \\ \text{by heat and mass}}} + \underbrace{S_{\text{gen}}}_{\substack{\text{Entropy} \\ \text{generation}}} = \underbrace{\Delta S_{\text{system}}}_{\substack{\text{Change} \\ \text{in entropy}}}$$

$$0 + S_{\text{gen}} = \Delta S_{\text{ice}} + \Delta S_{\text{water}}$$

where

$$\Delta S_{\text{water}} = \left(mc \ln \frac{T_2}{T_1} \right)_{\text{water}} = (1000 \text{ kg})(4.18 \text{ kJ/kg}\cdot\text{K}) \ln \frac{285.42 \text{ K}}{293 \text{ K}} = -109.6 \text{ kJ/K}$$

$$\Delta S_{\text{ice}} = (\Delta S_{\text{solid}} + \Delta S_{\text{melting}} + \Delta S_{\text{liquid}})_{\text{ice}}$$

$$= \left(\left(mc \ln \frac{T_{\text{melting}}}{T_1} \right)_{\text{solid}} + \frac{mh_{\text{if}}}{T_{\text{melting}}} + \left(mc \ln \frac{T_2}{T_1} \right)_{\text{liquid}} \right)_{\text{ice}}$$

$$= (80 \text{ kg}) \left((2.11 \text{ kJ/kg}\cdot\text{K}) \ln \frac{273 \text{ K}}{268 \text{ K}} + \frac{333.7 \text{ kJ/kg}}{273 \text{ K}} + (4.18 \text{ kJ/kg}\cdot\text{K}) \ln \frac{285.42 \text{ K}}{273 \text{ K}} \right)$$

$$= 115.8 \text{ kJ/K}$$

Then,

$$S_{\text{gen}} = \Delta S_{\text{water}} + \Delta S_{\text{ice}} = -109.6 + 115.8 = \mathbf{6.2 \text{ kJ/K}}$$

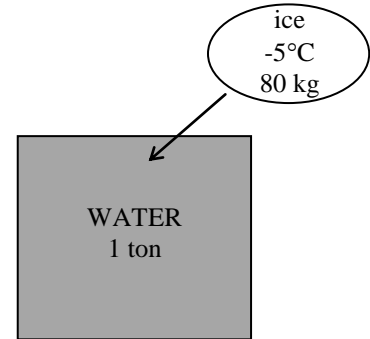

7-205 One ton of liquid water at 80°C is brought into a room. The final equilibrium temperature in the room and the entropy change during this process are to be determined.

Assumptions 1 The room is well insulated and well sealed. **2** The thermal properties of water and air are constant at room temperature. **3** The system is stationary and thus the kinetic and potential energy changes are zero. **4** There are no work interactions involved.

Properties The gas constant of air is $R = 0.287 \text{ kPa}\cdot\text{m}^3/\text{kg}\cdot\text{K}$ (Table A-1). The specific heat of water at room temperature is $c = 4.18 \text{ kJ}/\text{kg}\cdot^\circ\text{C}$ (Table A-3). For air is $c_v = 0.718 \text{ kJ}/\text{kg}\cdot^\circ\text{C}$ at room temperature.

Analysis (a) The volume and the mass of the air in the room are

$$V = 4 \times 5 \times 7 = 140 \text{ m}^3$$

$$m_{\text{air}} = \frac{P_1 V_1}{R T_1} = \frac{(100 \text{ kPa})(140 \text{ m}^3)}{(0.2870 \text{ kPa}\cdot\text{m}^3/\text{kg}\cdot\text{K})(295 \text{ K})} = 165.4 \text{ kg}$$

Taking the contents of the room, including the water, as our system, the energy balance can be written as

$$\underbrace{E_{\text{in}} - E_{\text{out}}}_{\substack{\text{Net energy transfer} \\ \text{by heat, work, and mass}}} = \underbrace{\Delta E_{\text{system}}}_{\substack{\text{Change in internal, kinetic,} \\ \text{potential, etc. energies}}} \rightarrow 0 = \Delta U = (\Delta U)_{\text{water}} + (\Delta U)_{\text{air}}$$

or

$$[mc(T_2 - T_1)]_{\text{water}} + [mc_v(T_2 - T_1)]_{\text{air}} = 0$$

Substituting,

$$(1000 \text{ kg})(4.18 \text{ kJ}/\text{kg}\cdot^\circ\text{C})(T_f - 80)^\circ\text{C} + (165.4 \text{ kg})(0.718 \text{ kJ}/\text{kg}\cdot^\circ\text{C})(T_f - 22)^\circ\text{C} = 0$$

It gives the final equilibrium temperature in the room to be

$$T_f = 78.4^\circ\text{C}$$

(b) Considering that the system is well-insulated and no mass is entering and leaving, the total entropy change during this process is the sum of the entropy changes of water and the room air,

$$\Delta S_{\text{total}} = S_{\text{gen}} = \Delta S_{\text{air}} + \Delta S_{\text{water}}$$

where

$$\Delta S_{\text{air}} = mc_v \ln \frac{T_2}{T_1} + mR \ln \frac{V_2}{V_1} = (165.4 \text{ kg})(0.718 \text{ kJ}/\text{kg}\cdot\text{K}) \ln \frac{351.4 \text{ K}}{295 \text{ K}} = 20.78 \text{ kJ}/\text{K}$$

$$\Delta S_{\text{water}} = mc \ln \frac{T_2}{T_1} = (1000 \text{ kg})(4.18 \text{ kJ}/\text{kg}\cdot\text{K}) \ln \frac{351.4 \text{ K}}{353 \text{ K}} = -18.99 \text{ kJ}/\text{K}$$

Substituting, the total entropy change is determined to be

$$\Delta S_{\text{total}} = 20.78 - 18.99 = 1.79 \text{ kJ}/\text{K}$$

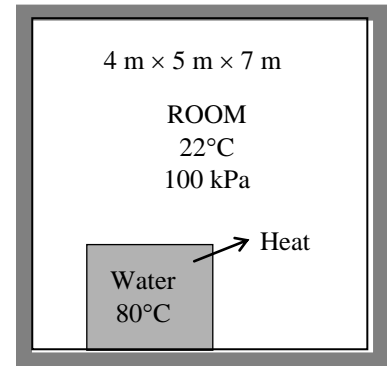

7-206 A well-insulated room is heated by a steam radiator, and the warm air is distributed by a fan. The average temperature in the room after 30 min, the entropy changes of steam and air, and the entropy generated during this process are to be determined.

Assumptions 1 Air is an ideal gas with constant specific heats at room temperature. 2 The kinetic and potential energy changes are negligible. 3 The air pressure in the room remains constant and thus the air expands as it is heated, and some warm air escapes.

Properties The gas constant of air is $R = 0.287 \text{ kPa}\cdot\text{m}^3/\text{kg}\cdot\text{K}$ (Table A-1). Also, $c_p = 1.005 \text{ kJ}/\text{kg}\cdot\text{K}$ for air at room temperature (Table A-2).

Analysis We first take the radiator as the system. This is a closed system since no mass enters or leaves. The energy balance for this closed system can be expressed as

$$\underbrace{E_{\text{in}} - E_{\text{out}}}_{\substack{\text{Net energy transfer} \\ \text{by heat, work, and mass}}} = \underbrace{\Delta E_{\text{system}}}_{\substack{\text{Change in internal, kinetic,} \\ \text{potential, etc. energies}}}$$

$$-Q_{\text{out}} = \Delta U = m(u_2 - u_1) \quad (\text{since } W = \text{KE} = \text{PE} = 0)$$

$$Q_{\text{out}} = m(u_1 - u_2)$$

Using data from the steam tables (Tables A-4 through A-6), some properties are determined to be

$$\left. \begin{array}{l} P_1 = 200 \text{ kPa} \\ T_1 = 200^\circ\text{C} \end{array} \right\} \begin{array}{l} \nu_1 = 1.0805 \text{ m}^3/\text{kg} \\ u_1 = 2654.6 \text{ kJ}/\text{kg} \\ s_1 = 7.5081 \text{ kJ}/\text{kg}\cdot\text{K} \end{array}$$

$$\left. \begin{array}{l} P_2 = 100 \text{ kPa} \\ (\nu_2 = \nu_1) \end{array} \right\} \begin{array}{l} \nu_f = 0.001043, \quad \nu_g = 1.6941 \text{ m}^3/\text{kg} \\ u_f = 417.40, \quad u_{fg} = 2088.2 \text{ kJ}/\text{kg} \\ s_f = 1.3028, \quad s_{fg} = 6.0562 \text{ kJ}/\text{kg}\cdot\text{K} \end{array}$$

$$x_2 = \frac{\nu_2 - \nu_f}{\nu_{fg}} = \frac{1.0805 - 0.001043}{1.6941 - 0.001043} = 0.6376$$

$$u_2 = u_f + x_2 u_{fg} = 417.40 + 0.6376 \times 2088.2 = 1748.7 \text{ kJ}/\text{kg}$$

$$s_2 = s_f + x_2 s_{fg} = 1.3028 + 0.6376 \times 6.0562 = 5.1642 \text{ kJ}/\text{kg}\cdot\text{K}$$

$$m = \frac{\nu_1}{\nu_1} = \frac{0.015 \text{ m}^3}{1.0805 \text{ m}^3/\text{kg}} = 0.01388 \text{ kg}$$

Substituting,

$$Q_{\text{out}} = (0.01388 \text{ kg})(2654.6 - 1748.7) \text{ kJ}/\text{kg} = 12.6 \text{ kJ}$$

The volume and the mass of the air in the room are $V = 4 \times 4 \times 5 = 80 \text{ m}^3$ and

$$m_{\text{air}} = \frac{P_1 \nu_1}{RT_1} = \frac{(100 \text{ kPa})(80 \text{ m}^3)}{(0.2870 \text{ kPa}\cdot\text{m}^3/\text{kg}\cdot\text{K})(283 \text{ K})} = 98.5 \text{ kg}$$

The amount of fan work done in 30 min is

$$W_{\text{fan, in}} = \dot{W}_{\text{fan, in}} \Delta t = (0.120 \text{ kJ}/\text{s})(30 \times 60 \text{ s}) = 216 \text{ kJ}$$

We now take the air in the room as the system. The energy balance for this closed system is expressed as

$$E_{\text{in}} - E_{\text{out}} = \Delta E_{\text{system}}$$

$$Q_{\text{in}} + W_{\text{fan, in}} - W_{\text{b, out}} = \Delta U$$

$$Q_{\text{in}} + W_{\text{fan, in}} = \Delta H \cong mc_p(T_2 - T_1)$$

since the boundary work and ΔU combine into ΔH for a constant pressure expansion or compression process.

Substituting,

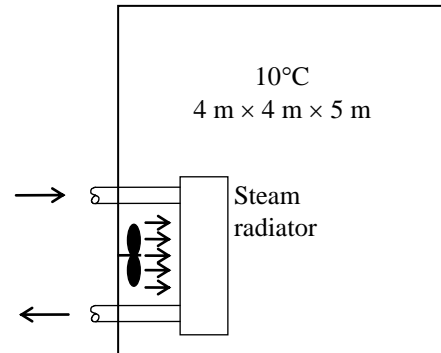

$$(12.6 \text{ kJ}) + (216 \text{ kJ}) = (98.5 \text{ kg})(1.005 \text{ kJ/kg}\cdot\text{C})(T_2 - 10)^\circ\text{C}$$

which yields

$$T_2 = \mathbf{12.3^\circ\text{C}}$$

Therefore, the air temperature in the room rises from 10°C to 12.3°C in 30 min.

(b) The entropy change of the steam is

$$\Delta S_{\text{steam}} = m(s_2 - s_1) = (0.01388 \text{ kg})(5.1642 - 7.5081) \text{ kJ/kg}\cdot\text{K} = \mathbf{-0.0325 \text{ kJ/K}}$$

(c) Noting that air expands at constant pressure, the entropy change of the air in the room is

$$\Delta S_{\text{air}} = mc_p \ln \frac{T_2}{T_1} - mR \ln \frac{P_2}{P_1} \stackrel{\text{Eq. 0}}{=} (98.5 \text{ kg})(1.005 \text{ kJ/kg}\cdot\text{K}) \ln \frac{285.3 \text{ K}}{283 \text{ K}} = \mathbf{0.8013 \text{ kJ/K}}$$

(d) We take the air in the room (including the steam radiator) as our system, which is a closed system. Noting that no heat or mass crosses the boundaries of this system, the entropy balance for it can be expressed as

$$\underbrace{S_{\text{in}} - S_{\text{out}}}_{\substack{\text{Net entropy transfer} \\ \text{by heat and mass}}} + \underbrace{S_{\text{gen}}}_{\substack{\text{Entropy} \\ \text{generation}}} = \underbrace{\Delta S_{\text{system}}}_{\substack{\text{Change} \\ \text{in entropy}}} \\ 0 + S_{\text{gen}} = \Delta S_{\text{steam}} + \Delta S_{\text{air}}$$

Substituting, the entropy generated during this process is determined to be

$$S_{\text{gen}} = \Delta S_{\text{steam}} + \Delta S_{\text{air}} = -0.0325 + 0.8013 = \mathbf{0.7688 \text{ kJ/K}}$$

7-207 An insulated cylinder initially contains a saturated liquid-vapor mixture of water at a specified temperature. The entire vapor in the cylinder is to be condensed isothermally by adding ice inside the cylinder. The amount of ice added and the entropy generation are to be determined.

Assumptions 1 Thermal properties of the ice are constant. **2** The cylinder is well-insulated and thus heat transfer is negligible. **3** There is no stirring by hand or a mechanical device (it will add energy).

Properties The specific heat of ice at about 0°C is $c = 2.11 \text{ kJ/kg}\cdot\text{°C}$ (Table A-3). The melting temperature and the heat of fusion of ice at 1 atm are 0°C and 333.7 kJ/kg.

Analysis (a) We take the contents of the cylinder (ice and saturated water) as our system, which is a closed system. Noting that the temperature and thus the pressure remains constant during this phase change process and thus $W_b + \Delta U = \Delta H$, the energy balance for this system can be written as

$$\underbrace{E_{in} - E_{out}}_{\substack{\text{Net energy transfer} \\ \text{by heat, work, and mass}}} = \underbrace{\Delta E_{system}}_{\substack{\text{Change in internal, kinetic,} \\ \text{potential, etc. energies}}}$$

$$W_{b,in} = \Delta U$$

$$\Delta H = 0$$

$$\Delta H_{ice} + \Delta H_{water} = 0$$

or

$$[mc(0^\circ\text{C} - T_1)_{solid} + mh_{if} + mc(T_2 - 0^\circ\text{C})_{liquid}]_{ice} + [m(h_2 - h_1)]_{water} = 0$$

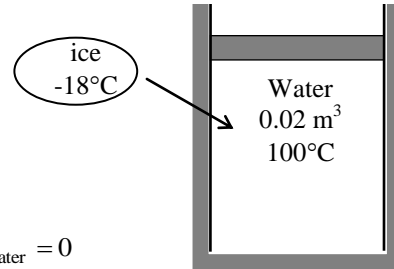

The properties of water at 100°C are (Table A-4)

$$\nu_f = 0.001043, \quad \nu_g = 1.6720 \text{ m}^3/\text{kg}$$

$$h_f = 419.17, \quad h_{fg} = 2256.4 \text{ kJ/kg}$$

$$s_f = 1.3072 \quad s_{fg} = 6.0490 \text{ kJ/kg}\cdot\text{K}$$

$$\nu_1 = \nu_f + x_1\nu_{fg} = 0.001043 + (0.1)(1.6720 - 0.001043) = 0.16814 \text{ m}^3/\text{kg}$$

$$h_1 = h_f + x_1h_{fg} = 419.17 + (0.1)(2256.4) = 644.81 \text{ kJ/kg}$$

$$s_1 = s_f + x_1s_{fg} = 1.3072 + (0.1)(6.0470) = 1.9119 \text{ kJ/kg}\cdot\text{K}$$

$$h_2 = h_{f@100^\circ\text{C}} = 419.17 \text{ kJ/kg}$$

$$s_2 = s_{f@100^\circ\text{C}} = 1.3072 \text{ kJ/kg}\cdot\text{K}$$

$$m_{\text{steam}} = \frac{\nu_1}{\nu_1} = \frac{0.02 \text{ m}^3}{0.16814 \text{ m}^3/\text{kg}} = 0.119 \text{ kg}$$

Noting that $T_{1,ice} = -18^\circ\text{C}$ and $T_2 = 100^\circ\text{C}$ and substituting gives

$$m\{(2.11 \text{ kJ/kg}\cdot\text{K})[0 - (-18)] + 333.7 \text{ kJ/kg} + (4.18 \text{ kJ/kg}\cdot\text{°C})(100 - 0)^\circ\text{C}\} + (0.119 \text{ kg})(419.17 - 644.81) \text{ kJ/kg} = 0$$

$$m = 0.034 \text{ kg} = \mathbf{34.0 \text{ g ice}}$$

(b) We take the ice and the steam as our system, which is a closed system. Considering that the tank is well-insulated and thus there is no heat transfer, the entropy balance for this closed system can be expressed as

$$\underbrace{S_{in} - S_{out}}_{\substack{\text{Net entropy transfer} \\ \text{by heat and mass}}} + \underbrace{S_{gen}}_{\substack{\text{Entropy} \\ \text{generation}}} = \underbrace{\Delta S_{system}}_{\substack{\text{Change} \\ \text{in entropy}}}$$

$$0 + S_{gen} = \Delta S_{ice} + \Delta S_{steam}$$

$$\Delta S_{\text{steam}} = m(s_2 - s_1) = (0.119 \text{ kg})(1.3072 - 1.9119) \text{ kJ/kg} \cdot \text{K} = -0.0719 \text{ kJ/K}$$

$$\begin{aligned} \Delta S_{\text{ice}} &= (\Delta S_{\text{solid}} + \Delta S_{\text{melting}} + \Delta S_{\text{liquid}})_{\text{ice}} = \left(\left(mc \ln \frac{T_{\text{melting}}}{T_1} \right)_{\text{solid}} + \frac{mh_{if}}{T_{\text{melting}}} + \left(mc \ln \frac{T_2}{T_1} \right)_{\text{liquid}} \right)_{\text{ice}} \\ &= (0.034 \text{ kg}) \left((2.11 \text{ kJ/kg} \cdot \text{K}) \ln \frac{273.15 \text{ K}}{255.15 \text{ K}} + \frac{333.7 \text{ kJ/kg}}{273.15 \text{ K}} + (4.18 \text{ kJ/kg} \cdot \text{K}) \ln \frac{373.15 \text{ K}}{273.15 \text{ K}} \right) \\ &= 0.0907 \text{ kJ/K} \end{aligned}$$

Then,

$$S_{\text{gen}} = \Delta S_{\text{steam}} + \Delta S_{\text{ice}} = -0.0719 + 0.0907 = \mathbf{0.0188 \text{ kJ/K}}$$

7-208 An evacuated bottle is surrounded by atmospheric air. A valve is opened, and air is allowed to fill the bottle. The amount of heat transfer through the wall of the bottle when thermal and mechanical equilibrium is established and the amount of entropy generated are to be determined.

Assumptions 1 This is an unsteady process since the conditions within the device are changing during the process, but it can be analyzed as a uniform-flow process since the state of fluid at the inlet remains constant. **2** Air is an ideal gas. **3** Kinetic and potential energies are negligible. **4** There are no work interactions involved. **5** The direction of heat transfer is to the air in the bottle (will be verified).

Properties The gas constant of air is $0.287 \text{ kPa}\cdot\text{m}^3/\text{kg}\cdot\text{K}$ (Table A-1).

Analysis We take the bottle as the system, which is a control volume since mass crosses the boundary. Noting that the microscopic energies of flowing and nonflowing fluids are represented by enthalpy h and internal energy u , respectively, the mass and energy balances for this uniform-flow system can be expressed as

$$\text{Mass balance: } m_{\text{in}} - m_{\text{out}} = \Delta m_{\text{system}} \rightarrow m_i = m_2 \quad (\text{since } m_{\text{out}} = m_{\text{initial}} = 0)$$

Energy balance:

$$\underbrace{E_{\text{in}} - E_{\text{out}}}_{\substack{\text{Net energy transfer} \\ \text{by heat, work, and mass}}} = \underbrace{\Delta E_{\text{system}}}_{\substack{\text{Change in internal, kinetic,} \\ \text{potential, etc. energies}}}$$

$$Q_{\text{in}} + m_i h_i = m_2 u_2 \quad (\text{since } W \cong E_{\text{out}} = E_{\text{initial}} = \text{ke} \cong \text{pe} \cong 0)$$

Combining the two balances:

$$Q_{\text{in}} = m_2(u_2 - h_i)$$

where

$$m_2 = \frac{P_2 V}{RT_2} = \frac{(95 \text{ kPa})(0.050 \text{ m}^3)}{(0.287 \text{ kPa}\cdot\text{m}^3/\text{kg}\cdot\text{K})(300 \text{ K})} = 0.05517 \text{ kg}$$

$$T_i = T_2 = 300 \text{ K} \xrightarrow{\text{Table A-17}} \begin{aligned} h_i &= 300.19 \text{ kJ/kg} \\ u_2 &= 214.07 \text{ kJ/kg} \end{aligned}$$

Substituting,

$$Q_{\text{in}} = (0.05517 \text{ kg})(214.07 - 300.19) \text{ kJ/kg} = -4.751 \text{ kJ} \rightarrow Q_{\text{out}} = \mathbf{4.751 \text{ kJ}}$$

Note that the negative sign for heat transfer indicates that the assumed direction is wrong. Therefore, we reverse the direction.

The entropy generated during this process is determined by applying the entropy balance on an *extended system* that includes the bottle and its immediate surroundings so that the boundary temperature of the extended system is the temperature of the surroundings at all times. The entropy balance for it can be expressed as

$$\underbrace{S_{\text{in}} - S_{\text{out}}}_{\substack{\text{Net entropy transfer} \\ \text{by heat and mass}}} + \underbrace{S_{\text{gen}}}_{\substack{\text{Entropy} \\ \text{generation}}} = \underbrace{\Delta S_{\text{system}}}_{\substack{\text{Change} \\ \text{in entropy}}}$$

$$m_i s_i - \frac{Q_{\text{out}}}{T_{\text{surr}}} + S_{\text{gen}} = \Delta S_{\text{tank}} = m_2 s_2 - m_1 s_1 \stackrel{\phi=0}{=} m_2 s_2$$

Therefore, the entropy generated during this process is

$$S_{\text{gen}} = -m_i s_i + m_2 s_2 + \frac{Q_{\text{out}}}{T_{\text{surr}}} = m_2 (s_2 - s_i) \stackrel{\phi=0}{=} + \frac{Q_{\text{out}}}{T_{\text{surr}}} = \frac{Q_{\text{out}}}{T_{\text{surr}}} = \frac{4.751 \text{ kJ}}{300 \text{ K}} = \mathbf{0.0158 \text{ kJ/K}}$$

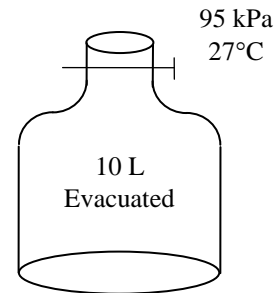

7-209 Water is heated from 16°C to 43°C by an electric resistance heater placed in the water pipe as it flows through a showerhead steadily at a rate of 10 L/min. The electric power input to the heater and the rate of entropy generation are to be determined. The reduction in power input and entropy generation as a result of installing a 50% efficient regenerator are also to be determined.

Assumptions 1 This is a steady-flow process since there is no change with time at any point within the system and thus $\Delta m_{CV} = 0$ and $\Delta E_{CV} = 0$. **2** Water is an incompressible substance with constant specific heats. **3** The kinetic and potential energy changes are negligible, $\Delta ke \cong \Delta pe \cong 0$. **4** Heat losses from the pipe are negligible.

Properties The density of water is given to be $\rho = 1$ kg/L. The specific heat of water at room temperature is $c = 4.18$ kJ/kg·°C (Table A-3).

Analysis (a) We take the pipe as the system. This is a *control volume* since mass crosses the system boundary during the process. We observe that there is only one inlet and one exit and thus $\dot{m}_1 = \dot{m}_2 = \dot{m}$. Then the energy balance for this steady-flow system can be expressed in the rate form as

$$\underbrace{\dot{E}_{in} - \dot{E}_{out}}_{\text{Rate of net energy transfer by heat, work, and mass}} = \underbrace{\Delta \dot{E}_{system}^{\cancel{0}}}_{\text{Rate of change in internal, kinetic, potential, etc. energies}} \stackrel{\cancel{0} \text{ (steady)}}{=} 0 \rightarrow \dot{E}_{in} = \dot{E}_{out}$$

$$\dot{W}_{e,in} + \dot{m}h_1 = \dot{m}h_2 \quad (\text{since } \Delta ke \cong \Delta pe \cong 0)$$

$$\dot{W}_{e,in} = \dot{m}(h_2 - h_1) = \dot{m}c(T_2 - T_1)$$

where

$$\dot{m} = \rho \dot{V} = (1 \text{ kg/L})(10 \text{ L/min}) = 10 \text{ kg/min}$$

Substituting,

$$\dot{W}_{e,in} = (10/60 \text{ kg/s})(4.18 \text{ kJ/kg} \cdot \text{°C})(43 - 16)^\circ\text{C} = \mathbf{18.8 \text{ kW}}$$

The rate of entropy generation in the heating section during this process is determined by applying the entropy balance on the heating section. Noting that this is a steady-flow process and heat transfer from the heating section is negligible,

$$\underbrace{\dot{S}_{in} - \dot{S}_{out}}_{\text{Rate of net entropy transfer by heat and mass}} + \underbrace{\dot{S}_{gen}}_{\text{Rate of entropy generation}} = \underbrace{\Delta \dot{S}_{system}^{\cancel{0}}}_{\text{Rate of change of entropy}} = 0$$

$$\dot{m}s_1 - \dot{m}s_2 + \dot{S}_{gen} = 0 \longrightarrow \dot{S}_{gen} = \dot{m}(s_2 - s_1)$$

Noting that water is an incompressible substance and substituting,

$$\dot{S}_{gen} = \dot{m}c \ln \frac{T_2}{T_1} = (10/60 \text{ kg/s})(4.18 \text{ kJ/kg} \cdot \text{K}) \ln \frac{316 \text{ K}}{289 \text{ K}} = \mathbf{0.0622 \text{ kJ/K}}$$

(b) The energy recovered by the heat exchanger is

$$\dot{Q}_{saved} = \epsilon \dot{Q}_{max} = \epsilon \dot{m}c(T_{max} - T_{min}) = 0.5(10/60 \text{ kg/s})(4.18 \text{ kJ/kg} \cdot \text{°C})(39 - 16)^\circ\text{C} = 8.0 \text{ kJ/s} = 8.0 \text{ kW}$$

Therefore, 8.0 kW less energy is needed in this case, and the required electric power in this case reduces to

$$\dot{W}_{in,new} = \dot{W}_{in,old} - \dot{Q}_{saved} = 18.8 - 8.0 = \mathbf{10.8 \text{ kW}}$$

Taking the cold water stream in the heat exchanger as our control volume (a steady-flow system), the temperature at which the cold water leaves the heat exchanger and enters the electric resistance heating section is determined from

$$\dot{Q} = \dot{m}c(T_{c,out} - T_{c,in})$$

Substituting,

$$8 \text{ kJ/s} = (10/60 \text{ kg/s})(4.18 \text{ kJ/kg} \cdot \text{°C})(T_{c,out} - 16^\circ\text{C})$$

It yields

$$T_{c,out} = 27.5^\circ\text{C} = 300.5 \text{ K}$$

The rate of entropy generation in the heating section in this case is determined similarly to be

$$\dot{S}_{gen} = \dot{m}c \ln \frac{T_2}{T_1} = (10/60 \text{ kg/s})(4.18 \text{ kJ/kg} \cdot \text{K}) \ln \frac{316 \text{ K}}{300.5 \text{ K}} = 0.0350 \text{ kJ/K}$$

Thus the reduction in the rate of entropy generation within the heating section is

$$\dot{S}_{reduction} = 0.0622 - 0.0350 = \mathbf{0.0272 \text{ kW/K}}$$

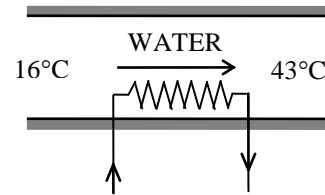



7-210 Using EES (or other) software, the work input to a multistage compressor is to be determined for a given set of inlet and exit pressures for any number of stages. The pressure ratio across each stage is assumed to be identical and the compression process to be polytropic. The compressor work is to be tabulated and plotted against the number of stages for $P_1 = 100$ kPa, $T_1 = 25^\circ\text{C}$, $P_2 = 1000$ kPa, and $n = 1.35$ for air.

Analysis The problem is solved using EES, and the results are tabulated and plotted below.

```
GAS$ = 'Air'
Nstage = 2 "number of stages of compression with intercooling, each having same pressure ratio."
n=1.35
MM=MOLARMASS(GAS$)
R_u = 8.314 [kJ/kmol-K]
R=R_u/MM
k=1.4
P1=100 [kPa]
T1=25 [C]
P2=1000 [kPa]
R_p = (P2/P1)^(1/Nstage)
W_dot_comp= Nstage*n*R*(T1+273)/(n-1)*((R_p)^((n-1)/n) - 1)
```

Nstage	W_{comp} [kJ/kg]
1	269.4
2	229.5
3	217.9
4	212.4
5	209.2
6	207.1
7	205.6
8	204.5
9	203.6
10	202.9

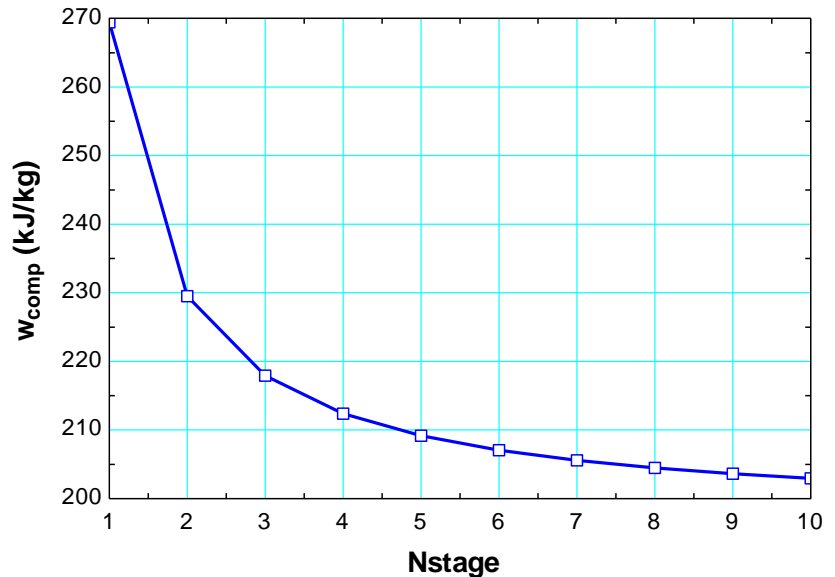

7-211 The inner and outer surfaces of a window glass are maintained at specified temperatures. The amount of heat transfer through the glass and the amount of entropy generation within the glass in 5 h are to be determined

Assumptions 1 Steady operating conditions exist since the surface temperatures of the glass remain constant at the specified values. **2** Thermal properties of the glass are constant.

Analysis The amount of heat transfer over a period of 5 h is

$$Q = \dot{Q}_{\text{cond}} \Delta t = (3.2 \text{ kJ/s})(5 \times 3600 \text{ s}) = \mathbf{57,600 \text{ kJ}}$$

We take the glass to be the system, which is a closed system. Under steady conditions, the rate form of the entropy balance for the glass simplifies to

$$\underbrace{\dot{S}_{\text{in}} - \dot{S}_{\text{out}}}_{\substack{\text{Rate of net entropy transfer} \\ \text{by heat and mass}}} + \underbrace{\dot{S}_{\text{gen}}}_{\substack{\text{Rate of entropy} \\ \text{generation}}} = \underbrace{\Delta \dot{S}_{\text{system}}}_{\substack{\text{Rate of change} \\ \text{of entropy}}} \stackrel{\neq 0}{=} 0$$

$$\frac{\dot{Q}_{\text{in}}}{T_{\text{b,in}}} - \frac{\dot{Q}_{\text{out}}}{T_{\text{b,out}}} + \dot{S}_{\text{gen, glass}} = 0$$

$$\frac{3200 \text{ W}}{283 \text{ K}} - \frac{3200 \text{ W}}{276 \text{ K}} + \dot{S}_{\text{gen, wall}} = 0 \rightarrow \dot{S}_{\text{gen, glass}} = \mathbf{0.287 \text{ W/K}}$$

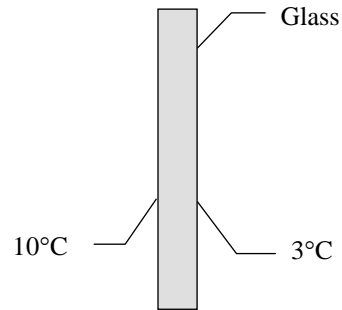

7-212 The inner and outer glasses of a double pane window are at specified temperatures. The rates of entropy transfer through both sides of the window and the rate of entropy generation within the window are to be determined.

Assumptions Steady operating conditions exist since the surface temperatures of the glass remain constant at the specified values.

Analysis The entropy flows associated with heat transfer through the left and right glasses are

$$\dot{S}_{\text{left}} = \frac{\dot{Q}_{\text{left}}}{T_{\text{left}}} = \frac{110 \text{ W}}{291 \text{ K}} = \mathbf{0.378 \text{ W/K}}$$

$$\dot{S}_{\text{right}} = \frac{\dot{Q}_{\text{right}}}{T_{\text{right}}} = \frac{110 \text{ W}}{279 \text{ K}} = \mathbf{0.394 \text{ W/K}}$$

We take the double pane window as the system, which is a closed system. In steady operation, the rate form of the entropy balance for this system can be expressed as

$$\underbrace{\dot{S}_{\text{in}} - \dot{S}_{\text{out}}}_{\substack{\text{Rate of net entropy transfer} \\ \text{by heat and mass}}} + \underbrace{\dot{S}_{\text{gen}}}_{\substack{\text{Rate of entropy} \\ \text{generation}}} = \underbrace{\Delta \dot{S}_{\text{system}}}_{\substack{\text{Rate of change} \\ \text{of entropy}}} \stackrel{\neq 0}{=} 0$$

$$\frac{\dot{Q}_{\text{in}}}{T_{\text{b,in}}} - \frac{\dot{Q}_{\text{out}}}{T_{\text{b,out}}} + \dot{S}_{\text{gen, system}} = 0$$

$$\frac{110 \text{ W}}{291 \text{ K}} - \frac{110 \text{ W}}{279 \text{ K}} + \dot{S}_{\text{gen, system}} = 0 \rightarrow \dot{S}_{\text{gen, system}} = \mathbf{0.016 \text{ W/K}}$$

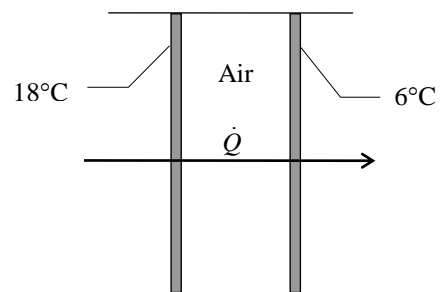

7-213 A hot water pipe at a specified temperature is losing heat to the surrounding air at a specified rate. The rate of entropy generation in the surrounding air due to this heat transfer are to be determined.

Assumptions Steady operating conditions exist.

Analysis We take the air in the vicinity of the pipe (excluding the pipe) as our system, which is a closed system.. The system extends from the outer surface of the pipe to a distance at which the temperature drops to the surroundings temperature. In steady operation, the rate form of the entropy balance for this system can be expressed as

$$\underbrace{\dot{S}_{\text{in}} - \dot{S}_{\text{out}}}_{\text{Rate of net entropy transfer by heat and mass}} + \underbrace{\dot{S}_{\text{gen}}}_{\text{Rate of entropy generation}} = \underbrace{\Delta\dot{S}_{\text{system}}}_{\text{Rate of change of entropy}} \stackrel{\neq 0}{=} 0$$

$$\frac{\dot{Q}_{\text{in}}}{T_{\text{b,in}}} - \frac{\dot{Q}_{\text{out}}}{T_{\text{b,out}}} + \dot{S}_{\text{gen,system}} = 0$$

$$\frac{2200 \text{ W}}{353 \text{ K}} - \frac{2200 \text{ W}}{278 \text{ K}} + \dot{S}_{\text{gen,system}} = 0 \rightarrow \dot{S}_{\text{gen,system}} = \mathbf{1.68 \text{ W/K}}$$

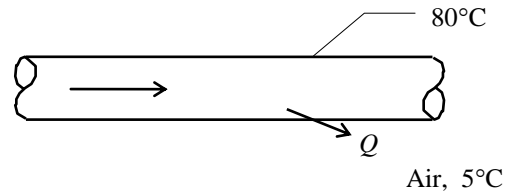

7-214 The turbocharger of an internal combustion engine consisting of a turbine driven by hot exhaust gases and a compressor driven by the turbine is considered. The air temperature at the compressor exit and the isentropic efficiency of the compressor are to be determined.

Assumptions **1** Steady operating conditions exist. **2** Kinetic and potential energy changes are negligible. **3** Exhaust gases have air properties and air is an ideal gas with constant specific heats.

Properties The specific heat of exhaust gases at the average temperature of 425°C is $c_p = 1.075 \text{ kJ/kg}\cdot\text{K}$ and properties of air at an anticipated average temperature of 100°C are $c_p = 1.011 \text{ kJ/kg}\cdot\text{K}$ and $k = 1.397$ (Table A-2).

Analysis (a) The turbine power output is determined from

$$\dot{W}_T = \dot{m}_{\text{exh}} c_p (T_1 - T_2)$$

$$= (0.02 \text{ kg/s})(1.075 \text{ kJ/kg}\cdot\text{°C})(450 - 400)\text{°C} = 1.075 \text{ kW}$$

For a mechanical efficiency of 95% between the turbine and the compressor,

$$\dot{W}_C = \eta_m \dot{W}_T = (0.95)(1.075 \text{ kW}) = 1.021 \text{ kW}$$

Then, the air temperature at the compressor exit becomes

$$\dot{W}_C = \dot{m}_{\text{air}} c_p (T_2 - T_1)$$

$$1.021 \text{ kW} = (0.018 \text{ kg/s})(1.011 \text{ kJ/kg}\cdot\text{°C})(T_2 - 70)\text{°C}$$

$$T_2 = 126.1\text{°C} \cong \mathbf{126\text{°C}}$$

(b) The air temperature at the compressor exit for the case of isentropic process is

$$T_{2s} = T_1 \left(\frac{P_2}{P_1} \right)^{(k-1)/k} = (70 + 273 \text{ K}) \left(\frac{135 \text{ kPa}}{95 \text{ kPa}} \right)^{(1.397-1)/1.397} = 379 \text{ K} = 106\text{°C}$$

The isentropic efficiency of the compressor is determined to be

$$\eta_C = \frac{T_{2s} - T_1}{T_2 - T_1} = \frac{106 - 70}{126.1 - 70} = \mathbf{0.642}$$

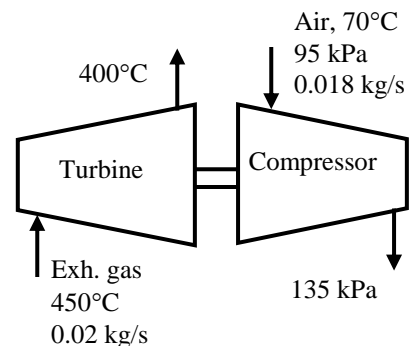

7-215 Air is allowed to enter an insulated piston-cylinder device until the volume of the air increases by 50%. The final temperature in the cylinder, the amount of mass that has entered, the work done, and the entropy generation are to be determined.

Assumptions 1 Kinetic and potential energy changes are negligible. **2** Air is an ideal gas with constant specific heats.

Properties The gas constant of air is $R = 0.287 \text{ kJ/kg}\cdot\text{K}$ and the specific heats of air at room temperature are $c_p = 1.005 \text{ kJ/kg}\cdot\text{K}$, $c_v = 0.718 \text{ kJ/kg}\cdot\text{K}$ (Table A-2).

Analysis The initial pressure in the cylinder is

$$P_1 = \frac{m_1 R T_1}{V_1} = \frac{(1.3 \text{ kg})(0.287 \text{ kPa}\cdot\text{m}^3/\text{kg}\cdot\text{K})(30 + 273 \text{ K})}{0.40 \text{ m}^3} = 282.6 \text{ kPa}$$

$$m_2 = \frac{P_2 V_2}{R T_2} = \frac{(282.6 \text{ kPa})(1.5 \times 0.40 \text{ m}^3)}{(0.287 \text{ kPa}\cdot\text{m}^3/\text{kg}\cdot\text{K})T_2} = \frac{590.8}{T_2}$$

A mass balance on the system gives the expression for the mass entering the cylinder

$$m_i = m_2 - m_1 = \frac{590.8}{T_2} - 1.3$$

(c) Noting that the pressure remains constant, the boundary work is determined to be

$$W_{b,\text{out}} = P_1(V_2 - V_1) = (282.6 \text{ kPa})(1.5 \times 0.40 - 0.40) \text{ m}^3 = \mathbf{56.52 \text{ kJ}}$$

(a) An energy balance on the system may be used to determine the final temperature

$$\begin{aligned} m_i h_i - W_{b,\text{out}} &= m_2 u_2 - m_1 u_1 \\ m_i c_p T_i - W_{b,\text{out}} &= m_2 c_v T_2 - m_1 c_v T_1 \end{aligned}$$

$$\left(\frac{590.8}{T_2} - 1.3 \right) (1.005)(70 + 273) - 56.52 = \left(\frac{590.8}{T_2} \right) (0.718)T_2 - (1.3)(0.718)(30 + 273)$$

There is only one unknown, which is the final temperature. By a trial-error approach or using EES, we find

$$T_2 = \mathbf{315.3 \text{ K}}$$

(b) The final mass and the amount of mass that has entered are

$$m_2 = \frac{590.8}{315.3} = 1.874 \text{ kg}$$

$$m_i = m_2 - m_1 = 1.874 - 1.3 = \mathbf{0.5742 \text{ kg}}$$

(d) The rate of entropy generation is determined from

$$\begin{aligned} S_{\text{gen}} &= m_2 s_2 - m_1 s_1 - m_i s_i = m_2 s_2 - m_1 s_1 - (m_2 - m_1) s_i = m_2 (s_2 - s_i) - m_1 (s_1 - s_i) \\ &= m_2 \left(c_p \ln \frac{T_2}{T_i} - R \ln \frac{P_2}{P_i} \right) - m_1 \left(c_p \ln \frac{T_1}{T_i} - R \ln \frac{P_1}{P_i} \right) \\ &= (1.874 \text{ kg}) \left[(1.005 \text{ kJ/kg}\cdot\text{K}) \ln \left(\frac{315.3 \text{ K}}{343 \text{ K}} \right) - (0.287 \text{ kJ/kg}\cdot\text{K}) \ln \left(\frac{282.6 \text{ kPa}}{500 \text{ kPa}} \right) \right] \\ &\quad - (1.3 \text{ kg}) \left[(1.005 \text{ kJ/kg}\cdot\text{K}) \ln \left(\frac{303 \text{ K}}{343 \text{ K}} \right) - (0.287 \text{ kJ/kg}\cdot\text{K}) \ln \left(\frac{282.6 \text{ kPa}}{500 \text{ kPa}} \right) \right] \\ &= \mathbf{0.09714 \text{ kJ/K}} \end{aligned}$$

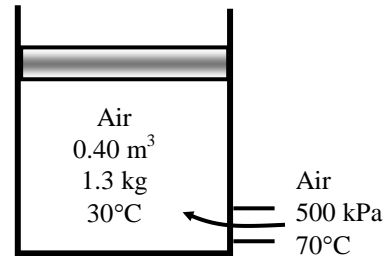

7-216 A cryogenic turbine in a natural gas liquefaction plant produces 115 kW of power. The efficiency of the turbine is to be determined.

Assumptions 1 The turbine operates steadily.

Properties The density of natural gas is given to be 423.8 kg/m^3 .

Analysis The maximum possible power that can be obtained from this turbine for the given inlet and exit pressures can be determined from

$$\dot{W}_{\max} = \frac{\dot{m}}{\rho} (P_{\text{in}} - P_{\text{out}}) = \frac{20 \text{ kg/s}}{423.8 \text{ kg/m}^3} (3000 - 300) \text{ kPa} = 127.4 \text{ kW}$$

Given the actual power, the efficiency of this cryogenic turbine becomes

$$\eta = \frac{\dot{W}}{\dot{W}_{\max}} = \frac{115 \text{ kW}}{127.4 \text{ kW}} = 0.903 = \mathbf{90.3\%}$$

This efficiency is also known as hydraulic efficiency since the cryogenic turbine handles natural gas in liquid state as the hydraulic turbine handles liquid water.

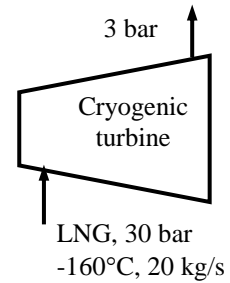

7-217 Heat is transferred from a tank to a heat reservoir until the temperature of the tank is reduced to the temperature of reservoir. The expressions for entropy changes are to be obtained and plotted against initial temperature in the tank.

Properties The constant-volume specific heat of air at 300 K is $c_v = 0.718$ kJ/kg·K (Table A-2a)

Analysis The entropy change of air in the tank is

$$\Delta S_{\text{air}} = m \left[c_v \ln \frac{T_2}{T_1} + R \ln \frac{V_2}{V_1} \right] = mc_v \ln \frac{T_2}{T_1}$$

The entropy change of heat reservoir is

$$\Delta S_{\text{HR}} = \frac{Q}{T_L} = \frac{mc_v(T_1 - T_2)}{T_L}$$

The total entropy change (i.e., entropy generation) is

$$S_{\text{gen}} = \Delta S_{\text{total}} = \Delta S_{\text{air}} + \Delta S_{\text{HR}} = mc_v \ln \frac{T_2}{T_1} + \frac{mc_v(T_1 - T_2)}{T_L}$$

The heat transfer will continue until $T_2 = T_L$. Now using $m = 2$ kg, $c_v = 0.718$ kJ/kg·K and $T_L = 300$ K, we plot entropy change terms against initial temperature as shown in the figure.

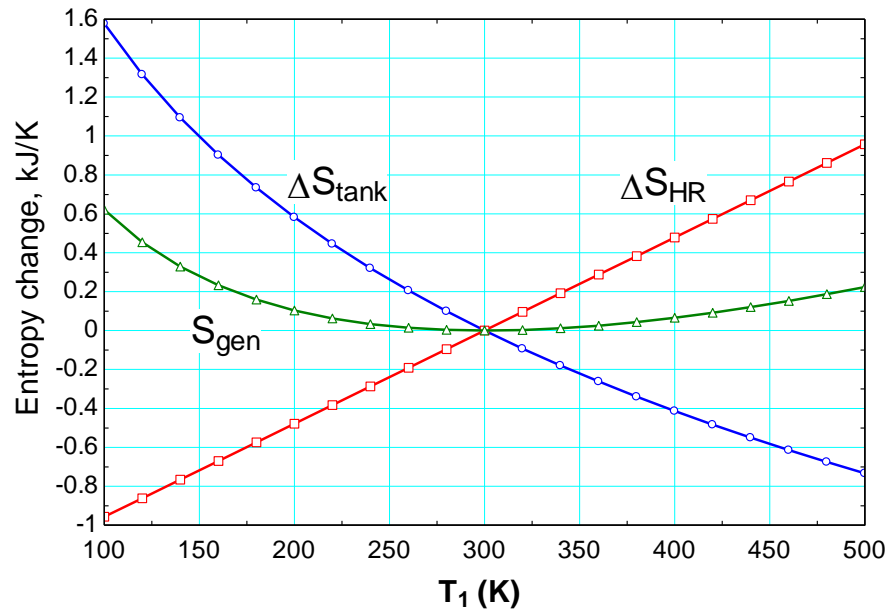

7-218 Two identical bodies at different temperatures are connected to each other through a heat engine. It is to be shown that the final common temperature of the two bodies will be $T_f = \sqrt{T_1 T_2}$ when the work output of the heat engine is maximum.

Analysis For maximum power production, the entropy generation must be zero. Taking the source, the sink, and the heat engine as our system, which is adiabatic, and noting that the entropy change for cyclic devices is zero, the entropy generation for this system can be expressed as

$$S_{\text{gen}} = (\Delta S)_{\text{source}} + (\Delta S)_{\text{engine}}^{\neq 0} + (\Delta S)_{\text{sink}} = 0$$

$$mc \ln \frac{T_f}{T_1} + 0 + mc \ln \frac{T_f}{T_2} = 0$$

$$\ln \frac{T_f}{T_1} + \ln \frac{T_f}{T_2} = 0 \longrightarrow \ln \frac{T_f \cdot T_f}{T_1 \cdot T_2} = 0 \longrightarrow T_f^2 = T_1 T_2$$

and thus

$$T_f = \sqrt{T_1 T_2}$$

for maximum power production.

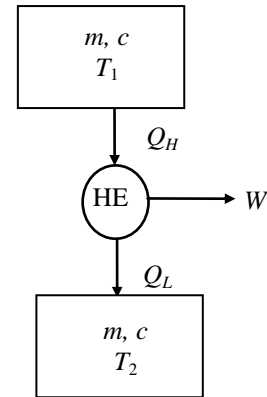

7-219 Heat is transferred from a tank to a heat engine which produces work. This work is stored in a work reservoir. The initial temperature of the air for maximum work and thermal efficiency, the total entropy change, work produced and thermal efficiency are to be determined for three initial temperatures.

Properties The constant-volume specific heat of air at 300 K is $c_v = 0.718 \text{ kJ/kg}\cdot\text{K}$ (Table A-2a)

Analysis (a) The entropy change of air in the tank is

$$\Delta S_{\text{tank}} = m \left[c_v \ln \frac{T_2}{T_1} + R \ln \frac{v_2}{v_1} \right] = mc_v \ln \frac{T_2}{T_1}$$

The heat transfer will continue until $T_2 = T_L$. Thus,

$$\Delta S_{\text{tank}} = mc_v \ln \frac{T_L}{T_1}$$

The entropy change of heat reservoir is

$$\Delta S_{\text{HR}} = \frac{Q_L}{T_L}$$

The entropy change of heat engine is zero since the engine is reversible and produces maximum work. The work reservoir involves no entropy change. Then, the total entropy change (i.e., entropy generation) is

$$\begin{aligned} S_{\text{gen}} &= \Delta S_{\text{total}} = \Delta S_{\text{tank}} + \Delta S_{\text{HR}} + \Delta S_{\text{HE}} + \Delta S_{\text{WR}} \\ &= \Delta S_{\text{tank}} + \Delta S_{\text{HR}} + 0 + 0 \end{aligned}$$

which becomes

$$S_{\text{gen}} = mc_v \ln \frac{T_L}{T_1} + \frac{Q_L}{T_L} \quad (1)$$

The expression for the thermal efficiency is

$$\eta_{\text{th}} = \frac{W}{Q_H} \quad (2)$$

or
$$\eta_{\text{th}} = 1 - \frac{Q_L}{Q_H} \quad (3)$$

Heat transfer from the tank is expressed as

$$Q_H = mc_v(T_1 - T_L) \quad (4)$$

In ideal operations, the entropy generation will be zero. Then using $m = 2 \text{ kg}$, $c_v = 0.718 \text{ kJ/kg}\cdot\text{K}$, $T_L = 300 \text{ K}$, $Q_L = 400 \text{ kJ}$ and solving equations (1), (2), (3) and (4) simultaneously using an equation solver such as EES we obtain

$$\begin{aligned} T_1 &= \mathbf{759.2\text{K}} \\ \eta_{\text{th}} &= \mathbf{0.3934} \\ W &= 259.4 \text{ kJ} \\ Q_H &= 659.4 \text{ kJ} \end{aligned}$$

(b) At the initial air temperature of 759.2 K, the entropy generation is zero and

$$\begin{aligned} S_{\text{gen}} &= \mathbf{0} \\ \eta_{\text{th}} &= \mathbf{0.3934} \\ W &= \mathbf{259.4\text{kJ}} \end{aligned}$$

At the initial air temperature of $759.2 - 100 = 659.2 \text{ K}$, we obtain

$$S_{\text{gen}} = 0.2029 \text{ kJ/K}$$

$$\eta_{\text{th}} = 0.2245$$

$$W = 115.8 \text{ kJ}$$

At the initial air temperature of $759.2 + 100 = 859.2 \text{ K}$, we obtain

$$S_{\text{gen}} = -0.1777 \text{ kJ/K}$$

$$\eta_{\text{th}} = 0.5019$$

$$W = 403.0 \text{ kJ}$$

A negative value for entropy generation indicates that this process is not possible with the given values.

(c) The thermal efficiency and the entropy generation as functions of the initial temperature of the air are plotted below:

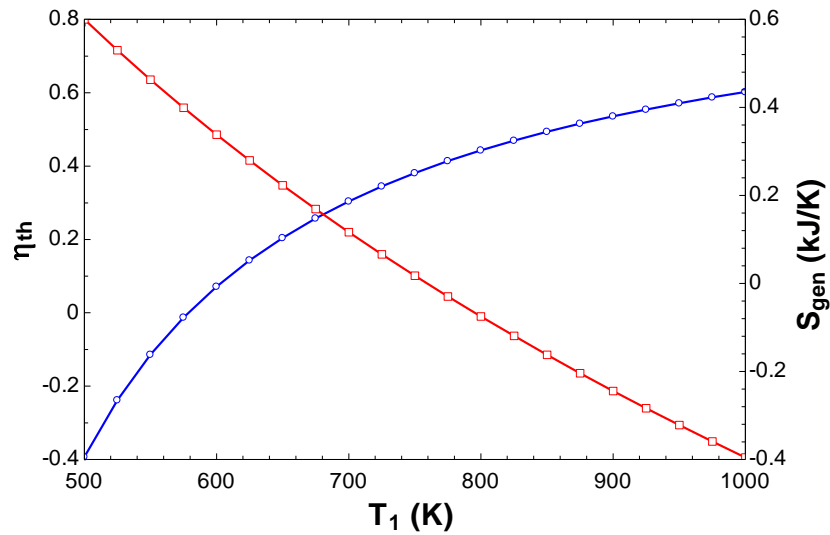

7-220 It is to be shown that for an ideal gas with constant specific heats the compressor and turbine isentropic efficiencies

may be written as $\eta_C = \frac{(P_2/P_1)^{(k-1)/k}}{(T_2/T_1)-1}$ and $\eta_T = \frac{(T_4/T_3)-1}{(P_4/P_3)^{(k-1)/k}-1}$.

Analysis The isentropic efficiency of a compressor for an ideal gas with constant specific heats is given by

$$\eta_C = \frac{h_{2s} - h_1}{h_2 - h_1} = \frac{c_p(T_{2s} - T_1)}{c_p(T_2 - T_1)} = \frac{T_{2s} - T_1}{T_2 - T_1}$$

The temperature at the compressor exit for the isentropic case is expressed as

$$T_{2s} = T_1 \left(\frac{P_2}{P_1} \right)^{(k-1)/k}$$

Substituting,

$$\eta_C = \frac{T_{2s} - T_1}{T_2 - T_1} = \frac{T_1 \left(\frac{P_2}{P_1} \right)^{(k-1)/k} - T_1}{T_2 - T_1} = \frac{T_1 \left[\left(\frac{P_2}{P_1} \right)^{(k-1)/k} - 1 \right]}{T_1 \left[\left(\frac{T_2}{T_1} \right) - 1 \right]} = \frac{\left(\frac{P_2}{P_1} \right)^{(k-1)/k} - 1}{\left(\frac{T_2}{T_1} \right) - 1}$$

The isentropic efficiency of a turbine for an ideal gas with constant specific heats is given by

$$\eta_T = \frac{h_4 - h_3}{h_{4s} - h_3} = \frac{c_p(T_4 - T_3)}{c_p(T_{4s} - T_3)} = \frac{T_4 - T_3}{T_{4s} - T_3}$$

The temperature at the turbine exit for the isentropic case is expressed as

$$T_{4s} = T_3 \left(\frac{P_4}{P_3} \right)^{(k-1)/k}$$

Substituting,

$$\eta_T = \frac{T_4 - T_3}{T_{4s} - T_3} = \frac{T_4 - T_3}{T_3 \left(\frac{P_4}{P_3} \right)^{(k-1)/k} - T_3} = \frac{T_3 \left[\left(\frac{T_4}{T_3} \right) - 1 \right]}{T_3 \left[\left(\frac{P_4}{P_3} \right)^{(k-1)/k} - 1 \right]} = \frac{\left(\frac{T_4}{T_3} \right) - 1}{\left(\frac{P_4}{P_3} \right)^{(k-1)/k} - 1}$$

7-221 An expression for the enthalpy change of an ideal gas during the isentropic process is to be obtained.

Analysis The expression is obtained as follows:

$$\begin{aligned} dh &= Td\zeta^0 + v dP = v dP \\ \Delta h &= \int v dP, \text{ where } v = \text{const } P^{-1/k} \\ \Delta h &= \int_1^2 \text{const } P^{-1/k} dP = \text{const} \left. \frac{P^{1-1/k}}{1-1/k} \right|_1^2 = \left. \frac{v P^{1/k} P^{1-1/k}}{1-1/k} \right|_1^2 \\ \Delta h &= \left. \frac{k}{k-1} P v \right|_1^2 = \left. \frac{k}{k-1} R T \right|_1^2 = \frac{k}{k-1} R (T_2 - T_1) \\ \Delta h &= C_p (T_2 - T_1) \end{aligned}$$

7-222 An empty rigid vessel is filled with a fluid adiabatically and without any work. The entropy generation is to be expressed.

Assumptions **1** The properties of the gas entering the vessel stay constant. **2** The fluid is an ideal gas with constant specific heats.

Analysis The conservation of mass principle in this case is

$$\frac{dm}{dt} = \dot{m}_{\text{in}}$$

When the combined first and second laws are reduced to the conditions of this system and the above result is substituted,

$$T_0 \dot{S}_{\text{gen}} = - \frac{d(U - T_0 S)}{dt} + (h - T_0 s)_{\text{in}} \frac{dm}{dt}$$

The integration and rearrangement of this result gives

$$\dot{S}_{\text{gen}} = \frac{m_f}{T_0} [h_i - u_2 - T_0 (s_i - s_2)]$$

At the end of the process, the mass in the control volume is

$$m_2 = \frac{P_2 \mathcal{V}}{RT_2}$$

According to the Gibbs equations,

$$s_i - s_2 = c_p \ln \frac{T_i}{T_2} - R \ln \frac{P_i}{P_2}$$

Using the specific heat models,

$$h_i - u_2 = c_p T_i - c_v T_2$$

When these are substituted into the integrated combined first and second laws, the final result is

$$\dot{S}_{\text{gen}} = \frac{P_2 \mathcal{V}}{RT_0 T_2} \left[c_p T_i - c_v T_2 - T_0 \left(c_p \ln \frac{T_i}{T_2} - R \ln \frac{P_i}{P_2} \right) \right]$$

where the subscript i and 2 stand for inlet and final states of the gas.

7-223 The temperature of an ideal gas is given as functions of entropy and specific volume. The expression for heat transfer is to be determined and compared to the result by a first law analysis.

Analysis The heat transfer may be expressed as

$$T(s, \nu) = A \nu^{1-k} \exp(s / c_\nu)$$

$$q = \frac{Q}{m} = \int_{s_1}^{s_2} T ds = \int_{s_1}^{s_2} A \nu^{1-k} \exp(s / c_\nu) ds$$

For $\nu = \text{constant}$, the integral becomes

$$q = A \nu^{1-k} \int_{s_1}^{s_2} \exp(s / c_\nu) ds = A \nu^{1-k} c_\nu \exp(s / c_\nu) \Big|_{s_1}^{s_2}$$

$$= A \nu^{1-k} c_\nu [\exp(s_2 / c_\nu) - \exp(s_1 / c_\nu)]$$

Noting that

$$T_1 = A \nu^{1-k} \exp(s_1 / c_\nu)$$

$$T_2 = A \nu^{1-k} \exp(s_2 / c_\nu)$$

We obtain

$$q = c_\nu (T_2 - T_1)$$

This result is the same as that given by applying the first law to a closed system undergoing a constant volume process.

7-224 An ideal gas undergoes a reversible, steady-flow process in a polytropic manner. An expression for heat transfer is to be obtained and evaluated when polytropic constant is equal to specific heat ratio.

Analysis (a) The conservation of mass and energy for the steady-flow process are

$$\sum_{\text{inlets}} \dot{m}_i = \sum_{\text{exits}} \dot{m}_e$$

$$\dot{Q}_{\text{net}} + \sum_{\text{inlets}} \dot{m}_i \left(h + \frac{V^2}{2} + gz \right)_i = \dot{W}_{\text{net}} + \sum_{\text{exits}} \dot{m}_e \left(h + \frac{V^2}{2} + gz \right)_e$$

where the sign of heat transfer is to the system and work is from the system. For one entrance, one exit, neglecting kinetic and potential energies, and unit mass flow, the conservation of mass and energy reduces to

$$q_{\text{net}} = w_{\text{net}} + (h_e - h_i)$$

The steady-flow, reversible work is defined as

$$w_{\text{net, sf, rev}} = - \int_i^e v dP = - \int_i^e C^{1/n} P^{-1/n} dP = - C^{1/n} \frac{P^{1-1/n}}{1-1/n} \Big|_i^e = - P^{1/n} v \frac{P^{1-1/n}}{1-1/n} \Big|_i^e = - \frac{n}{n-1} P v \Big|_i^e$$

$$= - \frac{n}{n-1} (P_e v_e - P_i v_i) = - \frac{n}{n-1} R(T_e - T_i)$$

Then

$$q_{\text{net}} = w_{\text{net}} + (h_e - h_i)$$

$$= - \frac{n}{n-1} R(T_e - T_i) + c_p(T_e - T_i)$$

$$= \left(c_p - \frac{n}{n-1} R \right) (T_e - T_i)$$

(b) When $n = k = c_p/c_v$, the heat transfer per unit mass flow becomes

$$q_{\text{net}} = \left(c_p - \frac{n}{n-1} R \right) (T_e - T_i) = (c_p - c_p)(T_e - T_i) = 0$$

When $n = k = c_p/c_v$, the heat transfer per unit mass is zero. For $n = k$ this reversible process is adiabatic and therefore isentropic.

7-225 The polytropic efficiency of a compressor is defined. A relation regarding this compressor operation is to be obtained.

Analysis The efficiency is defined as

$$\eta_{\infty,C} = \frac{dh_s}{dh}$$

For an ideal gas,

$$dh = c_p dT$$

Form Gibbs second equation,

$$dh = Tds + \nu dP$$

For the isentropic case,

$$dh_s = \nu dP$$

Substituting, we obtain

$$\eta_{\infty,C} = \frac{\nu dP}{c_p dT}$$

Then,

$$\eta_{\infty,C} c_p dT = \nu dP$$

$$\eta_{\infty,C} c_p dT = \frac{RT}{P}$$

Integrating between inlet (1) and exit (2) states,

$$\int_1^2 \frac{1}{\eta_{\infty,C}} \frac{R}{c_p} \frac{dP}{P} = \int_1^2 \frac{dT}{T}$$

$$\frac{1}{\eta_{\infty,C}} \frac{R}{c_p} \ln \frac{P_2}{P_1} = \ln \frac{T_2}{T_1}$$

This becomes

$$\frac{T_2}{T_1} = \left(\frac{P_2}{P_1} \right)^{\frac{1}{\eta_{\infty,C}} \frac{R}{c_p}} = \left(\frac{P_2}{P_1} \right)^{\frac{1}{\eta_{\infty,C}} \frac{k-1}{k}}$$

which is the desired expression.

Fundamentals of Engineering (FE) Exam Problems

7-226 Steam is compressed from 6 MPa and 300°C to 10 MPa isentropically. The final temperature of the steam is

- (a) 290°C (b) 300°C (c) 311°C (d) 371°C (e) 422°C

Answer (d) 371°C

Solution Solved by EES Software. Solutions can be verified by copying-and-pasting the following lines on a blank EES screen. (Similar problems and their solutions can be obtained easily by modifying numerical values).

```
P1=6000 "kPa"
T1=300 "C"
P2=10000 "kPa"
s2=s1
s1=ENTROPY(Steam_IAPWS,T=T1,P=P1)
T2=TEMPERATURE(Steam_IAPWS,s=s2,P=P2)
```

"Some Wrong Solutions with Common Mistakes:"

```
W1_T2=T1 "Assuming temperature remains constant"
W2_T2=TEMPERATURE(Steam_IAPWS,x=0,P=P2) "Saturation temperature at P2"
W3_T2=TEMPERATURE(Steam_IAPWS,x=0,P=P1) "Saturation temperature at P1"
```

7-227 An apple with an average mass of 0.12 kg and average specific heat of 3.65 kJ/kg.°C is cooled from 25°C to 5°C. The entropy change of the apple is

- (a) -0.705 kJ/K (b) -0.254 kJ/K (c) -0.0304 kJ/K (d) 0 kJ/K (e) 0.348 kJ/K

Answer (c) -0.0304 kJ/K

Solution Solved by EES Software. Solutions can be verified by copying-and-pasting the following lines on a blank EES screen. (Similar problems and their solutions can be obtained easily by modifying numerical values).

```
c=3.65 "kJ/kg.K"
m=0.12 "kg"
T1=25 "C"
T2=5 "C"
S_change=m*C*ln((T2+273)/(T1+273))
```

"Some Wrong Solutions with Common Mistakes:"

```
W1_S_change=C*ln((T2+273)/(T1+273)) "Not using mass"
W2_S_change=m*C*ln(T2/T1) "Using C"
W3_S_change=m*C*(T2-T1) "Using Wrong relation"
```

7-228 A piston-cylinder device contains 5 kg of saturated water vapor at 3 MPa. Now heat is rejected from the cylinder at constant pressure until the water vapor completely condenses so that the cylinder contains saturated liquid at 3 MPa at the end of the process. The entropy change of the system during this process is

- (a) 0 kJ/K (b) -3.5 kJ/K (c) -12.5 kJ/K (d) -17.7 kJ/K (e) -19.5 kJ/K

Answer (d) -17.7 kJ/K

Solution Solved by EES Software. Solutions can be verified by copying-and-pasting the following lines on a blank EES screen. (Similar problems and their solutions can be obtained easily by modifying numerical values).

```
P1=3000 "kPa"
m=5 "kg"
s_fg=(ENTROPY(Steam_IAPWS,P=P1,x=1)-ENTROPY(Steam_IAPWS,P=P1,x=0))
S_change=-m*s_fg "kJ/K"
```

7-229 Steam expands in an adiabatic turbine from 4 MPa and 500°C to 0.1 MPa at a rate of 2 kg/s. If steam leaves the turbine as saturated vapor, the power output of the turbine is

- (a) 2058 kW (b) 1910 kW (c) 1780 kW (d) 1674 kW (e) 1542 kW

Answer (e) 1542 kW

Solution Solved by EES Software. Solutions can be verified by copying-and-pasting the following lines on a blank EES screen. (Similar problems and their solutions can be obtained easily by modifying numerical values).

```
P1=4000 "kPa"
T1=500 "C"
P2=100 "kPa"
x2=1
m=2 "kg/s"
h1=ENTHALPY(Steam_IAPWS,T=T1,P=P1)
h2=ENTHALPY(Steam_IAPWS,x=x2,P=P2)
W_out=m*(h1-h2)
```

"Some Wrong Solutions with Common Mistakes:"

```
s1=ENTROPY(Steam_IAPWS,T=T1,P=P1)
h2s=ENTHALPY(Steam_IAPWS,s=s1,P=P2)
W1_Wout=m*(h1-h2s) "Assuming isentropic expansion"
```

7-230 Argon gas expands in an adiabatic turbine from 3 MPa and 750°C to 0.2 MPa at a rate of 5 kg/s. The maximum power output of the turbine is

- (a) 1.06 MW (b) 1.29 MW (c) 1.43 MW (d) 1.76 MW (e) 2.08 MW

Answer (d) 1.76 MW

Solution Solved by EES Software. Solutions can be verified by copying-and-pasting the following lines on a blank EES screen. (Similar problems and their solutions can be obtained easily by modifying numerical values).

```
Cp=0.5203
k=1.667
P1=3000 "kPa"
T1=750+273 "K"
m=5 "kg/s"
P2=200 "kPa"
"s2=s1"
T2=T1*(P2/P1)^((k-1)/k)
W_max=m*Cp*(T1-T2)
```

"Some Wrong Solutions with Common Mistakes:"

```
Cv=0.2081 "kJ/kg.K"
W1_Wmax=m*Cv*(T1-T2) "Using Cv"
T22=T1*(P2/P1)^((k-1)/k) "Using C instead of K"
W2_Wmax=m*Cp*(T1-T22)
W3_Wmax=Cp*(T1-T2) "Not using mass flow rate"
T24=T1*(P2/P1) "Assuming T is proportional to P, using C"
W4_Wmax=m*Cp*(T1-T24)
```

7-231 A unit mass of a substance undergoes an irreversible process from state 1 to state 2 while gaining heat from the surroundings at temperature T in the amount of q . If the entropy of the substance is s_1 at state 1, and s_2 at state 2, the entropy change of the substance Δs during this process is

- (a) $\Delta s < s_2 - s_1$ (b) $\Delta s > s_2 - s_1$ (c) $\Delta s = s_2 - s_1$ (d) $\Delta s = s_2 - s_1 + q/T$ (e) $\Delta s > s_2 - s_1 + q/T$

Answer (c) $\Delta s = s_2 - s_1$

7-232 A unit mass of an ideal gas at temperature T undergoes a reversible isothermal process from pressure P_1 to pressure P_2 while losing heat to the surroundings at temperature T in the amount of q . If the gas constant of the gas is R , the entropy change of the gas Δs during this process is

- (a) $\Delta s = R \ln(P_2/P_1)$ (b) $\Delta s = R \ln(P_2/P_1) - q/T$ (c) $\Delta s = R \ln(P_1/P_2)$ (d) $\Delta s = R \ln(P_1/P_2) - q/T$ (e) $\Delta s = 0$

Answer (c) $\Delta s = R \ln(P_1/P_2)$

7-233 Helium gas is compressed from 27°C and 3.5 m³/kg to 0.775 m³/kg in a reversible adiabatic manner. The temperature of helium after compression is

- (a) 74°C (b) 122°C (c) 547°C (d) 709°C (e) 1082°C

Answer (c) 547°C

Solution Solved by EES Software. Solutions can be verified by copying-and-pasting the following lines on a blank EES screen. (Similar problems and their solutions can be obtained easily by modifying numerical values).

```
k=1.667
v1=3.5 "m^3/kg"
T1=27 "C"
v2=0.775 "m^3/kg"
"s2=s1"
"The exit temperature is determined from isentropic compression relation,"
T2=(T1+273)*(v1/v2)^(k-1) "K"
T2_C= T2-273 "C"
```

"Some Wrong Solutions with Common Mistakes:"

```
W1_T2=T1 "Assuming temperature remains constant"
W2_T2=T1*(v1/v2)^(k-1) "Using C instead of K"
W3_T2=(T1+273)*(v1/v2)-273 "Assuming T is proportional to v"
W4_T2=T1*(v1/v2) "Assuming T is proportional to v, using C"
```

7-234 Heat is lost through a plane wall steadily at a rate of 600 W. If the inner and outer surface temperatures of the wall are 20°C and 5°C, respectively, the rate of entropy generation within the wall is

- (a) 0.11 W/K (b) 4.21 W/K (c) 2.10 W/K (d) 42.1 W/K (e) 90.0 W/K

Answer (a) 0.11 W/K

Solution Solved by EES Software. Solutions can be verified by copying-and-pasting the following lines on a blank EES screen. (Similar problems and their solutions can be obtained easily by modifying numerical values).

```
Q=600 "W"
T1=20+273 "K"
T2=5+273 "K"
"Entropy balance S_in - S_out + S_gen= DS_system for the wall for steady operation gives"
Q/T1-Q/T2+S_gen=0 "W/K"
```

"Some Wrong Solutions with Common Mistakes:"

```
Q/(T1+273)-Q/(T2+273)+W1_Sgen=0 "Using C instead of K"
W2_Sgen=Q/((T1+T2)/2) "Using avegage temperature in K"
W3_Sgen=Q/((T1+T2)/2-273) "Using avegage temperature in C"
W4_Sgen=Q/(T1-T2+273) "Using temperature difference in K"
```

7-235 Air is compressed steadily and adiabatically from 17°C and 90 kPa to 200°C and 400 kPa. Assuming constant specific heats for air at room temperature, the isentropic efficiency of the compressor is

- (a) 0.76 (b) 0.94 (c) 0.86 (d) 0.84 (e) 1.00

Answer (d) 0.84

Solution Solved by EES Software. Solutions can be verified by copying-and-pasting the following lines on a blank EES screen. (Similar problems and their solutions can be obtained easily by modifying numerical values).

```
Cp=1.005 "kJ/kg.K"
k=1.4
P1=90 "kPa"
T1=17 "C"
P2=400 "kPa"
T2=200 "C"
T2s=(T1+273)*(P2/P1)^((k-1)/k)-273
Eta_comp=(Cp*(T2s-T1))/(Cp*(T2-T1))
```

"Some Wrong Solutions with Common Mistakes:"

```
T2sW1=T1*(P2/P1)^((k-1)/k) "Using C instead of K in finding T2s"
W1_Eta_comp=(Cp*(T2sW1-T1))/(Cp*(T2-T1))
W2_Eta_comp=T2s/T2 "Using wrong definition for isentropic efficiency, and using C"
W3_Eta_comp=(T2s+273)/(T2+273) "Using wrong definition for isentropic efficiency, with K"
```

7-236 Argon gas expands in an adiabatic turbine steadily from 600°C and 800 kPa to 80 kPa at a rate of 2.5 kg/s. For an isentropic efficiency of 88%, the power produced by the turbine is

- (a) 240 kW (b) 361 kW (c) 414 kW (d) 602 kW (e) 777 kW

Answer (d) 602 kW

Solution Solved by EES Software. Solutions can be verified by copying-and-pasting the following lines on a blank EES screen. (Similar problems and their solutions can be obtained easily by modifying numerical values).

```
Cp=0.5203 "kJ/kg-K"
k=1.667
m=2.5 "kg/s"
T1=600 "C"
P1=800 "kPa"
P2=80 "kPa"
T2s=(T1+273)*(P2/P1)^((k-1)/k)-273
Eta_turb=0.88
Eta_turb=(Cp*(T2-T1))/(Cp*(T2s-T1))
W_out=m*Cp*(T1-T2)
```

"Some Wrong Solutions with Common Mistakes:"

```
T2sW1=T1*(P2/P1)^((k-1)/k) "Using C instead of K to find T2s"
Eta_turb=(Cp*(T2W1-T1))/(Cp*(T2sW1-T1))
W1_Wout=m*Cp*(T1-T2W1)
Eta_turb=(Cp*(T2s-T1))/(Cp*(T2W2-T1)) "Using wrong definition for isentropic efficiency, and using C"
W2_Wout=m*Cp*(T1-T2W2)
W3_Wout=Cp*(T1-T2) "Not using mass flow rate"
Cv=0.3122 "kJ/kg.K"
W4_Wout=m*Cv*(T1-T2) "Using Cv instead of Cp"
```

7-237 Water enters a pump steadily at 100 kPa at a rate of 35 L/s and leaves at 800 kPa. The flow velocities at the inlet and the exit are the same, but the pump exit where the discharge pressure is measured is 6.1 m above the inlet section. The minimum power input to the pump is

- (a) 34 kW (b) 22 kW (c) 27 kW (d) 52 kW (e) 44 kW

Answer (c) 27 kW

Solution Solved by EES Software. Solutions can be verified by copying-and-pasting the following lines on a blank EES screen. (Similar problems and their solutions can be obtained easily by modifying numerical values).

```
V=0.035 "m^3/s"
g=9.81 "m/s^2"
h=6.1 "m"
P1=100 "kPa"
T1=20 "C"
P2=800 "kPa"
"Pump power input is minimum when compression is reversible and thus w=v(P2-P1)+Dpe"
v1=VOLUME(Steam_IAPWS,T=T1,P=P1)
m=V/v1
W_min=m*v1*(P2-P1)+m*g*h/1000 "kPa.m^3/s=kW"
"(The effect of 6.1 m elevation difference turns out to be small)"
```

"Some Wrong Solutions with Common Mistakes:"

```
W1_Win=m*v1*(P2-P1) "Disregarding potential energy"
W2_Win=m*v1*(P2-P1)-m*g*h/1000 "Subtracting potential energy instead of adding"
W3_Win=m*v1*(P2-P1)+m*g*h "Not using the conversion factor 1000 in PE term"
W4_Win=m*v1*(P2+P1)+m*g*h/1000 "Adding pressures instead of subtracting"
```

7-238 Air is to be compressed steadily and isentropically from 1 atm to 16 atm by a two-stage compressor. To minimize the total compression work, the intermediate pressure between the two stages must be

- (a) 3 atm (b) 4 atm (c) 8.5 atm (d) 9 atm (e) 12 atm

Answer (b) 4 atm

Solution Solved by EES Software. Solutions can be verified by copying-and-pasting the following lines on a blank EES screen. (Similar problems and their solutions can be obtained easily by modifying numerical values).

```
P1=1 "atm"
P2=16 "atm"
P_mid=SQRT(P1*P2)
```

"Some Wrong Solutions with Common Mistakes:"

```
W1_P=(P1+P2)/2 "Using average pressure"
W2_P=P1*P2/2 "Half of product"
```

7-239 Helium gas enters an adiabatic nozzle steadily at 500°C and 600 kPa with a low velocity, and exits at a pressure of 90 kPa. The highest possible velocity of helium gas at the nozzle exit is

- (a) 1475 m/s (b) 1662 m/s (c) 1839 m/s (d) 2066 m/s (e) 3040 m/s

Answer (d) 2066 m/s

Solution Solved by EES Software. Solutions can be verified by copying-and-pasting the following lines on a blank EES screen. (Similar problems and their solutions can be obtained easily by modifying numerical values).

$k=1.667$

$C_p=5.1926$ "kJ/kg.K"

$C_v=3.1156$ "kJ/kg.K"

$T_1=500$ "C"

$P_1=600$ "kPa"

$Vel_1=0$

$P_2=90$ "kPa"

" $s_2=s_1$ for maximum exit velocity"

"The exit velocity will be highest for isentropic expansion,"

$T_2=(T_1+273)*(P_2/P_1)^{(k-1)/k}-273$ "C"

"Energy balance for this case is $h+ke=\text{constant}$ for the fluid stream ($Q=W=pe=0$)"

$(0.5*Vel_1^2)/1000+C_p*T_1=(0.5*Vel_2^2)/1000+C_p*T_2$

"Some Wrong Solutions with Common Mistakes:"

$T_{2a}=T_1*(P_2/P_1)^{(k-1)/k}$ "Using C for temperature"

$(0.5*Vel_1^2)/1000+C_p*T_1=(0.5*W1_Vel_2^2)/1000+C_p*T_{2a}$

$T_{2b}=T_1*(P_2/P_1)^{(k-1)/k}$ "Using C_v "

$(0.5*Vel_1^2)/1000+C_v*T_1=(0.5*W2_Vel_2^2)/1000+C_v*T_{2b}$

$T_{2c}=T_1*(P_2/P_1)^k$ "Using wrong relation"

$(0.5*Vel_1^2)/1000+C_p*T_1=(0.5*W3_Vel_2^2)/1000+C_p*T_{2c}$

7-240 Combustion gases with a specific heat ratio of 1.3 enter an adiabatic nozzle steadily at 800°C and 800 kPa with a low velocity, and exit at a pressure of 85 kPa. The lowest possible temperature of combustion gases at the nozzle exit is

- (a) 43°C (b) 237°C (c) 367°C (d) 477°C (e) 640°C

Answer (c) 367°C

Solution Solved by EES Software. Solutions can be verified by copying-and-pasting the following lines on a blank EES screen. (Similar problems and their solutions can be obtained easily by modifying numerical values).

$k=1.3$

$T_1=800$ "C"

$P_1=800$ "kPa"

$P_2=85$ "kPa"

"Nozzle exit temperature will be lowest for isentropic operation"

$T_2=(T_1+273)*(P_2/P_1)^{(k-1)/k}-273$

"Some Wrong Solutions with Common Mistakes:"

$W1_T_2=T_1*(P_2/P_1)^{(k-1)/k}$ "Using C for temperature"

$W2_T_2=(T_1+273)*(P_2/P_1)^{(k-1)/k}$ "Not converting the answer to C"

$W3_T_2=T_1*(P_2/P_1)^k$ "Using wrong relation"

7-241 Steam enters an adiabatic turbine steadily at 400°C and 5 MPa, and leaves at 20 kPa. The highest possible percentage of mass of steam that condenses at the turbine exit and leaves the turbine as a liquid is

- (a) 4% (b) 8% (c) 12% (d) 18% (e) 0%

Answer (d) 18%

Solution Solved by EES Software. Solutions can be verified by copying-and-pasting the following lines on a blank EES screen. (Similar problems and their solutions can be obtained easily by modifying numerical values).

```
P1=5000 "kPa"
T1=400 "C"
P2=20 "kPa"
s2=s1
s1=ENTROPY(Steam_IAPWS,T=T1,P=P1)
x2=QUALITY(Steam_IAPWS,s=s2,P=P2)
moisture=1-x2
```

7-242 Liquid water enters an adiabatic piping system at 15°C at a rate of 8 kg/s. If the water temperature rises by 0.2°C during flow due to friction, the rate of entropy generation in the pipe is

- (a) 23 W/K (b) 55 W/K (c) 68 W/K (d) 220 W/K (e) 443 W/K

Answer (a) 23 W/K

Solution Solved by EES Software. Solutions can be verified by copying-and-pasting the following lines on a blank EES screen. (Similar problems and their solutions can be obtained easily by modifying numerical values).

```
Cp=4180 "J/kg.K"
m=8 "kg/s"
T1=15 "C"
T2=15.2 "C"
S_gen=m*Cp*ln((T2+273)/(T1+273)) "W/K"
```

"Some Wrong Solutions with Common Mistakes:"

```
W1_Sgen=m*Cp*ln(T2/T1) "Using deg. C"
W2_Sgen=Cp*ln(T2/T1) "Not using mass flow rate with deg. C"
W3_Sgen=Cp*ln((T2+273)/(T1+273)) "Not using mass flow rate with deg. C"
```

7-243 Liquid water is to be compressed by a pump whose isentropic efficiency is 75 percent from 0.2 MPa to 5 MPa at a rate of $0.15 \text{ m}^3/\text{min}$. The required power input to this pump is

- (a) 4.8 kW (b) 6.4 kW (c) 9.0 kW (d) 16.0 kW (e) 12.0 kW

Answer (d) 16.0 kW

Solution Solved by EES Software. Solutions can be verified by copying-and-pasting the following lines on a blank EES screen. (Similar problems and their solutions can be obtained easily by modifying numerical values).

```
V=0.15/60 "m^3/s"
rho=1000 "kg/m^3"
v1=1/rho
m=rho*v "kg/s"
P1=200 "kPa"
Eta_pump=0.75
P2=5000 "kPa"
"Reversible pump power input is w =mv(P2-P1) = V(P2-P1)"
W_rev=m*v1*(P2-P1) "kPa.m^3/s=kW"
W_pump=W_rev/Eta_pump
```

"Some Wrong Solutions with Common Mistakes:"

```
W1_Wpump=W_rev*Eta_pump "Multiplying by efficiency"
W2_Wpump=W_rev "Disregarding efficiency"
W3_Wpump=m*v1*(P2+P1)/Eta_pump "Adding pressures instead of subtracting"
```

7-244 Steam enters an adiabatic turbine at 8 MPa and 500°C at a rate of 18 kg/s , and exits at 0.2 MPa and 300°C . The rate of entropy generation in the turbine is

- (a) 0 kW/K (b) 7.2 kW/K (c) 21 kW/K (d) 15 kW/K (e) 17 kW/K

Answer (c) 21 kW/K

Solution Solved by EES Software. Solutions can be verified by copying-and-pasting the following lines on a blank EES screen. (Similar problems and their solutions can be obtained easily by modifying numerical values).

```
P1=8000 "kPa"
T1=500 "C"
m=18 "kg/s"
P2=200 "kPa"
T2=300 "C"
s1=ENTROPY(Steam_IAPWS,T=T1,P=P1)
s2=ENTROPY(Steam_IAPWS,T=T2,P=P2)
S_gen=m*(s2-s1) "kW/K"
```

"Some Wrong Solutions with Common Mistakes:"

```
W1_Sgen=0 "Assuming isentropic expansion"
```

7-245 Helium gas is compressed steadily from 90 kPa and 25°C to 800 kPa at a rate of 2 kg/min by an adiabatic compressor. If the compressor consumes 80 kW of power while operating, the isentropic efficiency of this compressor is

- (a) 54.0% (b) 80.5% (c) 75.8% (d) 90.1% (e) 100%

Answer (d) 90.1%

Solution Solved by EES Software. Solutions can be verified by copying-and-pasting the following lines on a blank EES screen. (Similar problems and their solutions can be obtained easily by modifying numerical values).

```
Cp=5.1926 "kJ/kg-K"
Cv=3.1156 "kJ/kg.K"
k=1.667
m=2/60 "kg/s"
T1=25 "C"
P1=90 "kPa"
P2=800 "kPa"
W_comp=80 "kW"
T2s=(T1+273)*(P2/P1)^((k-1)/k)-273
W_s=m*Cp*(T2s-T1)
Eta_comp=W_s/W_comp
```

"Some Wrong Solutions with Common Mistakes:"

```
T2sA=T1*(P2/P1)^((k-1)/k) "Using C instead of K"
W1_Eta_comp=m*Cp*(T2sA-T1)/W_comp
W2_Eta_comp=m*Cv*(T2s-T1)/W_comp "Using Cv instead of Cp"
```

7-246 ... 7-250 Design and Essay Problems



Solutions Manual for
Thermodynamics: An Engineering Approach
8th Edition
Yunus A. Çengel, Michael A. Boles
McGraw-Hill, 2015

Chapter 8

EXERGY

PROPRIETARY AND CONFIDENTIAL

This Manual is the proprietary property of McGraw-Hill Education and protected by copyright and other state and federal laws. By opening and using this Manual the user agrees to the following restrictions, and if the recipient does not agree to these restrictions, the Manual should be promptly returned unopened to McGraw-Hill Education: **This Manual is being provided only to authorized professors and instructors for use in preparing for the classes using the affiliated textbook. No other use or distribution of this Manual is permitted. This Manual may not be sold and may not be distributed to or used by any student or other third party. No part of this Manual may be reproduced, displayed or distributed in any form or by any means, electronic or otherwise, without the prior written permission of McGraw-Hill Education.**

Exergy, Irreversibility, Reversible Work, and Second-Law Efficiency

8-1C The dead state.

8-2C Yes; exergy is a function of the state of the surroundings as well as the state of the system.

8-3C Useful work differs from the actual work by the surroundings work. They are identical for systems that involve no surroundings work such as steady-flow systems.

8-4C Yes.

8-5C No, not necessarily. The well with the higher temperature will have a higher exergy.

8-6C The system that is at the temperature of the surroundings has zero exergy. But the system that is at a lower temperature than the surroundings has some exergy since we can run a heat engine between these two temperature levels.

8-7C The second-law efficiency is a measure of the performance of a device relative to its performance under reversible conditions. It differs from the first law efficiency in that it is not a conversion efficiency.

8-8C No. The power plant that has a lower thermal efficiency may have a higher second-law efficiency.

8-9C No. The refrigerator that has a lower COP may have a higher second-law efficiency.

8-10C A process with $W_{rev} = 0$ is reversible if it involves no actual useful work. Otherwise it is irreversible.

8-11C Yes.

8-12 Windmills are to be installed at a location with steady winds to generate power. The minimum number of windmills that need to be installed is to be determined.

Assumptions Air is at standard conditions of 1 atm and 25°C

Properties The gas constant of air is 0.287 kPa·m³/kg·K (Table A-1).

Analysis The exergy or work potential of the blowing air is the kinetic energy it possesses,

$$\text{Exergy} = ke = \frac{V^2}{2} = \frac{(6 \text{ m/s})^2}{2} \left(\frac{1 \text{ kJ/kg}}{1000 \text{ m}^2/\text{s}^2} \right) = 0.0180 \text{ kJ/kg}$$

At standard atmospheric conditions (25°C, 101 kPa), the density and the mass flow rate of air are

$$\rho = \frac{P}{RT} = \frac{101 \text{ kPa}}{(0.287 \text{ kPa} \cdot \text{m}^3 / \text{kg} \cdot \text{K})(298 \text{ K})} = 1.18 \text{ m}^3 / \text{kg}$$

and

$$\dot{m} = \rho AV_1 = \rho \frac{\pi D^2}{4} V_1 = (1.18 \text{ kg/m}^3) (\pi / 4) (40 \text{ m})^2 (6 \text{ m/s}) = 8904 \text{ kg/s}$$

Thus,

$$\text{Available Power} = \dot{m}ke = (8904 \text{ kg/s})(0.0180 \text{ kJ/kg}) = 160.3 \text{ kW}$$

The minimum number of windmills that needs to be installed is

$$N = \frac{\dot{W}_{\text{total}}}{\dot{W}} = \frac{1500 \text{ kW}}{160.3 \text{ kW}} = 9.4 \cong \mathbf{10 \text{ windmills}}$$

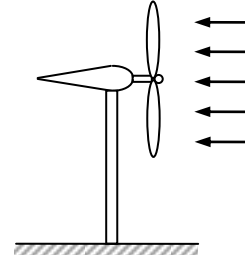

8-13E Saturated steam is generated in a boiler by transferring heat from the combustion gases. The wasted work potential associated with this heat transfer process is to be determined. Also, the effect of increasing the temperature of combustion gases on the irreversibility is to be discussed.

Assumptions 1 Steady operating conditions exist. 2 Kinetic and potential energy changes are negligible.

Analysis The properties of water at the inlet and outlet of the boiler and at the dead state are (Tables A-4E through A-6E)

$$\begin{aligned} P_1 = 200 \text{ psia} & \left. \begin{array}{l} h_1 = h_f = 355.46 \text{ Btu/lbm} \\ s_1 = s_f = 0.54379 \text{ Btu/lbm} \cdot \text{R} \end{array} \right\} \\ P_2 = 200 \text{ psia} & \left. \begin{array}{l} h_2 = h_g = 1198.8 \text{ Btu/lbm} \\ s_2 = s_g = 1.5460 \text{ Btu/lbm} \cdot \text{R} \end{array} \right\} \\ T_0 = 80^\circ\text{F} & \left. \begin{array}{l} h_0 \cong h_f @ 80^\circ\text{F} = 48.07 \text{ Btu/lbm} \\ s_0 \cong s_f @ 80^\circ\text{F} = 0.09328 \text{ Btu/lbm} \cdot \text{R} \end{array} \right\} \\ P_0 = 14.7 \text{ psia} & \end{aligned}$$

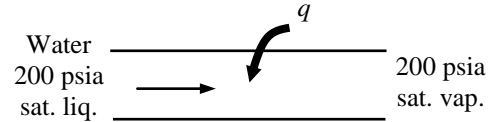

The heat transfer during the process is

$$q_{\text{in}} = h_2 - h_1 = 1198.8 - 355.46 = 843.3 \text{ Btu/lbm}$$

The entropy generation associated with this process is

$$\begin{aligned} s_{\text{gen}} &= \Delta s_w + \Delta s_R = (s_2 - s_1) - \frac{q_{\text{in}}}{T_R} \\ &= (1.5460 - 0.54379) \text{ Btu/lbm} \cdot \text{R} - \frac{843.3 \text{ Btu/lbm}}{(500 + 460) \text{ R}} \\ &= 0.12377 \text{ Btu/lbm} \cdot \text{R} \end{aligned}$$

The wasted work potential (exergy destruction) is

$$x_{\text{dest}} = T_0 s_{\text{gen}} = (80 + 460 \text{ R})(0.12377 \text{ Btu/lbm} \cdot \text{R}) = \mathbf{66.8 \text{ Btu/lbm}}$$

The work potential (exergy) of the steam stream is

$$\begin{aligned} \Delta \psi_w &= h_2 - h_1 - T_0(s_2 - s_1) \\ &= (1198.8 - 355.46) \text{ Btu/lbm} - (540 \text{ R})(1.5460 - 0.54379) \text{ Btu/lbm} \cdot \text{R} \\ &= 302.1 \text{ Btu/lbm} \end{aligned}$$

Increasing the temperature of combustion gases does not effect the work potential of steam stream since it is determined by the states at which water enters and leaves the boiler.

Discussion This problem may also be solved as follows:

Exergy transfer by heat transfer:

$$x_{\text{heat}} = q \left(1 - \frac{T_0}{T_R} \right) = (843.3) \left(1 - \frac{540}{960} \right) = 368.9 \text{ Btu/lbm}$$

Exergy increase of steam:

$$\Delta \psi_w = 302.1 \text{ Btu/lbm}$$

The net exergy destruction:

$$x_{\text{dest}} = x_{\text{heat}} - \Delta \psi_w = 368.9 - 302.1 = \mathbf{66.8 \text{ Btu/lbm}}$$

8-14 Water is to be pumped to a high elevation lake at times of low electric demand for use in a hydroelectric turbine at times of high demand. For a specified energy storage capacity, the minimum amount of water that needs to be stored in the lake is to be determined.

Assumptions The evaporation of water from the lake is negligible.

Analysis The exergy or work potential of the water is the potential energy it possesses,

$$\text{Exergy} = \text{PE} = mgh$$

Thus,

$$m = \frac{PE}{gh} = \frac{5 \times 10^6 \text{ kWh}}{(9.8 \text{ m/s}^2)(75 \text{ m})} \left(\frac{3600 \text{ s}}{1 \text{ h}} \right) \left(\frac{1000 \text{ m}^2/\text{s}^2}{1 \text{ kW} \cdot \text{s}/\text{kg}} \right) = \mathbf{2.45 \times 10^{10} \text{ kg}}$$

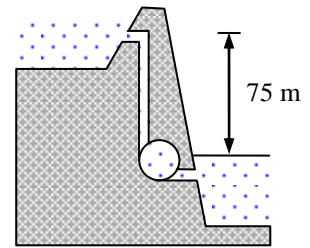

8-15 A body contains a specified amount of thermal energy at a specified temperature. The amount that can be converted to work is to be determined.

Analysis The amount of heat that can be converted to work is simply the amount that a reversible heat engine can convert to work,

$$\eta_{\text{th,rev}} = 1 - \frac{T_0}{T_H} = 1 - \frac{298 \text{ K}}{650 \text{ K}} = 0.5415$$

$$W_{\text{max,out}} = W_{\text{rev,out}} = \eta_{\text{th,rev}} Q_{\text{in}}$$

$$= (0.5415)(100 \text{ kJ})$$

$$= \mathbf{54.2 \text{ kJ}}$$

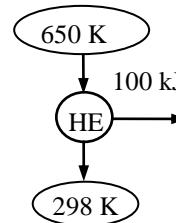

8-16 The thermal efficiency of a heat engine operating between specified temperature limits is given. The second-law efficiency of an engine is to be determined.

Analysis The thermal efficiency of a reversible heat engine operating between the same temperature reservoirs is

$$\eta_{\text{th,rev}} = 1 - \frac{T_0}{T_H} = 1 - \frac{293 \text{ K}}{1200 + 273 \text{ K}} = 0.801$$

Thus,

$$\eta_{\text{II}} = \frac{\eta_{\text{th}}}{\eta_{\text{th,rev}}} = \frac{0.40}{0.801} = \mathbf{49.9\%}$$

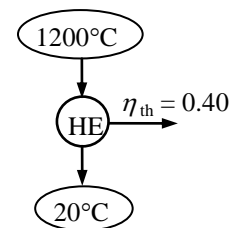

8-17 A heat reservoir at a specified temperature can supply heat at a specified rate. The exergy of this heat supplied is to be determined.

Analysis The exergy of the supplied heat, in the rate form, is the amount of power that would be produced by a reversible heat engine,

$$\eta_{\text{th,max}} = \eta_{\text{th,rev}} = 1 - \frac{T_0}{T_H} = 1 - \frac{298 \text{ K}}{1500 \text{ K}} = 0.8013$$

$$\begin{aligned} \text{Exergy} &= \dot{W}_{\text{max,out}} = \dot{W}_{\text{rev,out}} = \eta_{\text{th,rev}} \dot{Q}_{\text{in}} \\ &= (0.8013)(150,000 / 3600 \text{ kJ/s}) \\ &= \mathbf{33.4 \text{ kW}} \end{aligned}$$

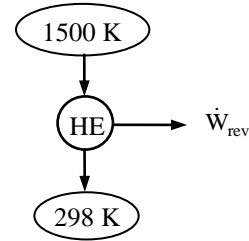

8-18 A heat engine receives heat from a source at a specified temperature at a specified rate, and rejects the waste heat to a sink. For a given power output, the reversible power, the rate of irreversibility, and the 2nd law efficiency are to be determined.

Analysis (a) The reversible power is the power produced by a reversible heat engine operating between the specified temperature limits,

$$\eta_{\text{th,max}} = \eta_{\text{th,rev}} = 1 - \frac{T_L}{T_H} = 1 - \frac{320 \text{ K}}{1100 \text{ K}} = 0.7091$$

$$\dot{W}_{\text{rev,out}} = \eta_{\text{th,rev}} \dot{Q}_{\text{in}} = (0.7091)(400 \text{ kJ/s}) = \mathbf{283.6 \text{ kW}}$$

(b) The irreversibility rate is the difference between the reversible power and the actual power output:

$$\dot{I} = \dot{W}_{\text{rev,out}} - \dot{W}_{\text{u,out}} = 283.6 - 120 = \mathbf{163.6 \text{ kW}}$$

(c) The second law efficiency is determined from its definition,

$$\eta_{\text{II}} = \frac{W_{\text{u,out}}}{W_{\text{rev,out}}} = \frac{120 \text{ kW}}{283.6 \text{ kW}} = 0.423 = \mathbf{42.3\%}$$

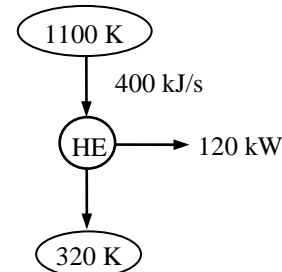



8-19 Problem 8-18 is reconsidered. The effect of reducing the temperature at which the waste heat is rejected on the reversible power, the rate of irreversibility, and the second law efficiency is to be studied and the results are to be plotted.

Analysis The problem is solved using EES, and the solution is given below.

"Input Data"

T_H= 1100 [K]

Q_dot_H= 400 [kJ/s]

{T_L=320 [K]}

W_dot_out = 120 [kW]

T_Lsurr =25 [C]

"The reversible work is the maximum work done by the Carnot Engine between T_H and T_L:"

Eta_Carnot=1 - T_L/T_H

W_dot_rev=Q_dot_H*Eta_Carnot

"The irreversibility is given as:"

I_dot = W_dot_rev-W_dot_out

"The thermal efficiency is, in percent:"

Eta_th = Eta_Carnot*Convert(, %)

"The second law efficiency is, in percent:"

Eta_II = W_dot_out/W_dot_rev*Convert(, %)

T _L [K]	W _{rev} [kJ/s]	I [kJ/s]	η _{II} [%]
500	218.2	98.18	55
477.6	226.3	106.3	53.02
455.1	234.5	114.5	51.17
432.7	242.7	122.7	49.45
410.2	250.8	130.8	47.84
387.8	259	139	46.33
365.3	267.2	147.2	44.92
342.9	275.3	155.3	43.59
320.4	283.5	163.5	42.33
298	291.6	171.6	41.15

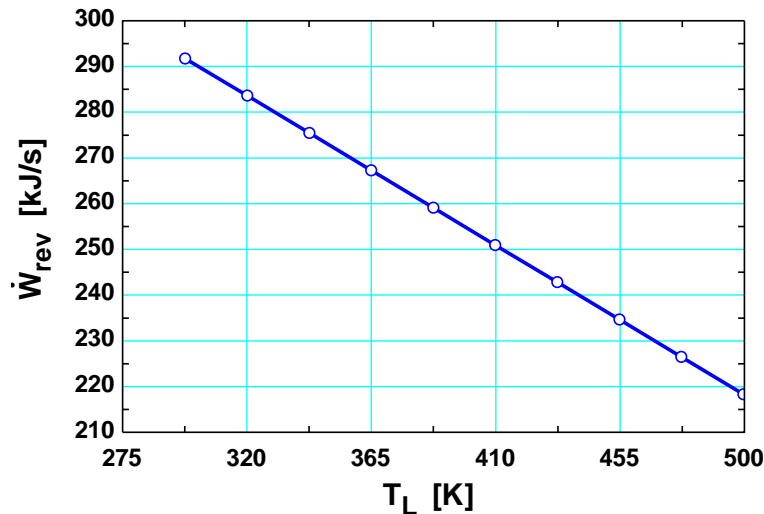

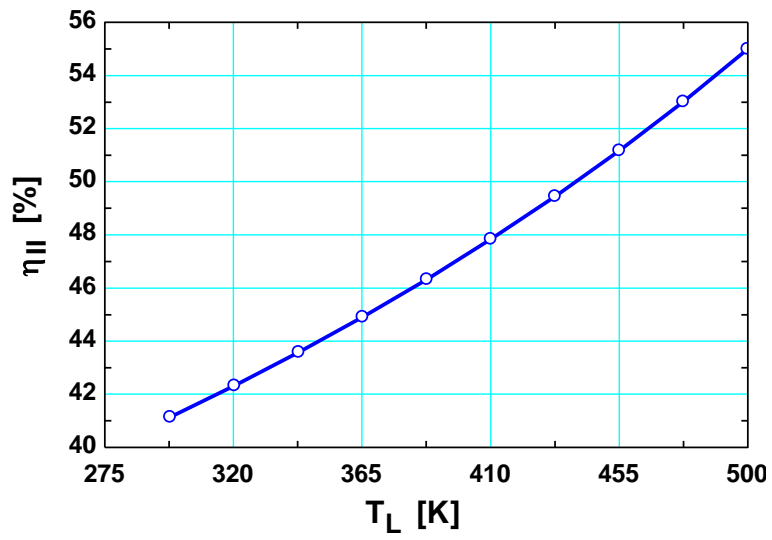
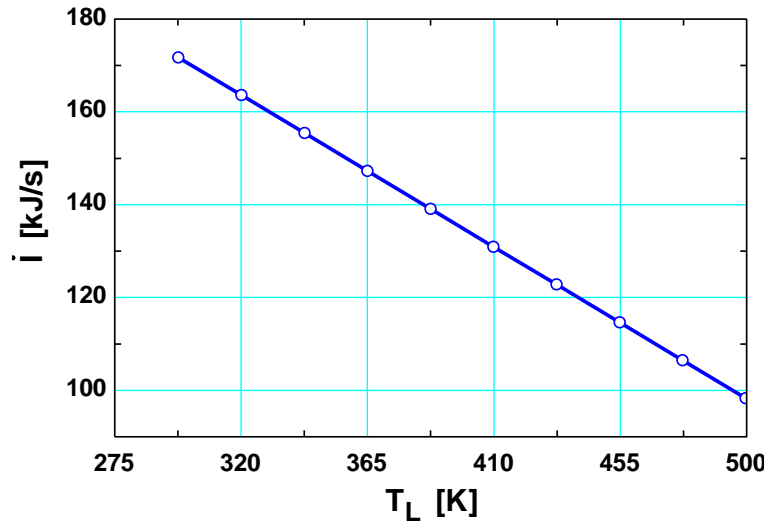

8-20E The thermal efficiency and the second-law efficiency of a heat engine are given. The source temperature is to be determined.

Analysis From the definition of the second law efficiency,

$$\eta_{II} = \frac{\eta_{th}}{\eta_{th,rev}} \longrightarrow \eta_{th,rev} = \frac{\eta_{th}}{\eta_{II}} = \frac{0.25}{0.50} = 0.50$$

Thus,

$$\eta_{th,rev} = 1 - \frac{T_L}{T_H} \longrightarrow T_H = T_L / (1 - \eta_{th,rev}) = (510 \text{ R}) / 0.50 = \mathbf{1020 \text{ R}}$$

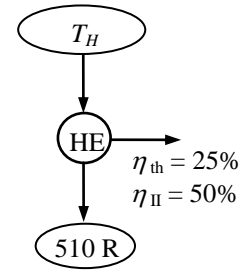

8-21 A house is maintained at a specified temperature by electric resistance heaters. The reversible work for this heating process and irreversibility are to be determined.

Analysis We consider a reversible heat pump operation as the reversible counterpart of the irreversible process of heating the house by resistance heaters. Instead of using electricity input for resistance heaters, it is used to power a reversible heat pump. The reversible work is the minimum work required to accomplish this process, and the irreversibility is the difference between the reversible work and the actual electrical work consumed. The actual power input is

$$\dot{W}_{in} = \dot{Q}_{out} = \dot{Q}_H = 50,000 \text{ kJ/h} = 13.89 \text{ kW}$$

The COP of a reversible heat pump operating between the specified temperature limits is

$$\text{COP}_{HP,rev} = \frac{1}{1 - T_L / T_H} = \frac{1}{1 - 277.15 / 298.15} = 14.20$$

Thus,

$$\dot{W}_{rev,in} = \frac{\dot{Q}_H}{\text{COP}_{HP,rev}} = \frac{13.89 \text{ kW}}{14.20} = \mathbf{0.978 \text{ kW}}$$

and

$$\dot{I} = \dot{W}_{u,in} - \dot{W}_{rev,in} = 13.89 - 0.978 = \mathbf{12.91 \text{ kW}}$$

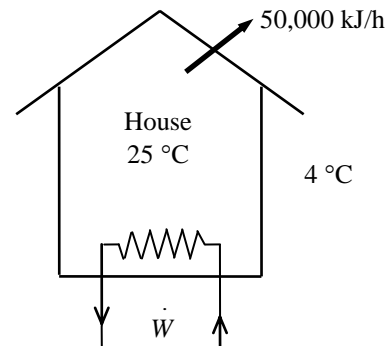

8-22E A freezer is maintained at a specified temperature by removing heat from it at a specified rate. The power consumption of the freezer is given. The reversible power, irreversibility, and the second-law efficiency are to be determined.

Analysis (a) The reversible work is the minimum work required to accomplish this task, which is the work that a reversible refrigerator operating between the specified temperature limits would consume,

$$COP_{R,rev} = \frac{1}{T_H / T_L - 1} = \frac{1}{535 / 480 - 1} = 8.73$$

$$\dot{W}_{rev,in} = \frac{\dot{Q}_L}{COP_{R,rev}} = \frac{75 \text{ Btu/min}}{8.73} \left(\frac{1 \text{ hp}}{42.41 \text{ Btu/min}} \right) = \mathbf{0.20 \text{ hp}}$$

(b) The irreversibility is the difference between the reversible work and the actual electrical work consumed,

$$\dot{I} = \dot{W}_{u,in} - \dot{W}_{rev,in} = 0.70 - 0.20 = \mathbf{0.50 \text{ hp}}$$

(c) The second law efficiency is determined from its definition,

$$\eta_{II} = \frac{\dot{W}_{rev}}{\dot{W}_u} = \frac{0.20 \text{ hp}}{0.7 \text{ hp}} = \mathbf{28.9\%}$$

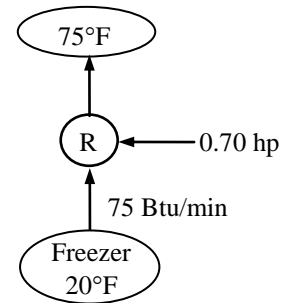

8-23 It is to be shown that the power produced by a wind turbine is proportional to the cube of the wind velocity and the square of the blade span diameter.

Analysis The power produced by a wind turbine is proportional to the kinetic energy of the wind, which is equal to the product of the kinetic energy of air per unit mass and the mass flow rate of air through the blade span area. Therefore,

$$\begin{aligned} \text{Wind power} &= (\text{Efficiency})(\text{Kinetic energy})(\text{Mass flow rate of air}) \\ &= \eta_{\text{wind}} \frac{V^2}{2} (\rho AV) = \eta_{\text{wind}} \frac{V^2}{2} \rho \frac{\pi D^2}{4} V \\ &= \eta_{\text{wind}} \rho \frac{\pi V^3 D^2}{8} = (\text{Constant}) V^3 D^2 \end{aligned}$$

which completes the proof that wind power is proportional to the cube of the wind velocity and to the square of the blade span diameter.

Exergy Analysis of Closed Systems

8-24C Yes, it can. For example, the 1st law efficiency of a reversible heat engine operating between the temperature limits of 300 K and 1000 K is 70%. However, the second law efficiency of this engine, like all reversible devices, is 100%.

8-25 A fixed mass of helium undergoes a process from a specified state to another specified state. The increase in the useful energy potential of helium is to be determined.

Assumptions 1 At specified conditions, helium can be treated as an ideal gas.
2 Helium has constant specific heats at room temperature.

Properties The gas constant of helium is $R = 2.0769 \text{ kJ/kg}\cdot\text{K}$ (Table A-1). The constant volume specific heat of helium is $c_v = 3.1156 \text{ kJ/kg}\cdot\text{K}$ (Table A-2).

Analysis From the ideal-gas entropy change relation,

$$\begin{aligned} s_2 - s_1 &= c_{v,\text{avg}} \ln \frac{T_2}{T_1} + R \ln \frac{v_2}{v_1} \\ &= (3.1156 \text{ kJ/kg}\cdot\text{K}) \ln \frac{353 \text{ K}}{288 \text{ K}} + (2.0769 \text{ kJ/kg}\cdot\text{K}) \ln \frac{0.5 \text{ m}^3/\text{kg}}{3 \text{ m}^3/\text{kg}} \\ &= -3.087 \text{ kJ/kg}\cdot\text{K} \end{aligned}$$

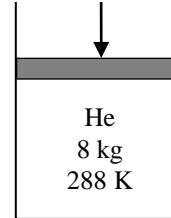

The increase in the useful potential of helium during this process is simply the increase in exergy,

$$\begin{aligned} \Phi_2 - \Phi_1 &= -m[(u_1 - u_2) - T_0(s_1 - s_2) + P_0(v_1 - v_2)] \\ &= -(8 \text{ kg})\{(3.1156 \text{ kJ/kg}\cdot\text{K})(288 - 353) \text{ K} - (298 \text{ K})(3.087 \text{ kJ/kg}\cdot\text{K}) \\ &\quad + (100 \text{ kPa})(3 - 0.5) \text{ m}^3 / \text{kg}[\text{kJ/kPa}\cdot\text{m}^3]\} \\ &= \mathbf{6980 \text{ kJ}} \end{aligned}$$

8-26E Air is expanded in an adiabatic closed system with an isentropic efficiency of 95%. The second law efficiency of the process is to be determined.

Assumptions 1 Kinetic and potential energy changes are negligible. **2** The process is adiabatic, and thus there is no heat transfer. **3** Air is an ideal gas with constant specific heats.

Properties The properties of air at room temperature are $c_p = 0.240$ Btu/lbm·R, $c_v = 0.171$ Btu/lbm·R, $k = 1.4$, and $R = 0.06855$ Btu/lbm·R (Table A-2Ea).

Analysis We take the air as the system. This is a *closed system* since no mass crosses the boundaries of the system. The energy balance for this system can be expressed as

$$\underbrace{E_{\text{in}} - E_{\text{out}}}_{\substack{\text{Net energy transfer} \\ \text{by heat, work, and mass}}} = \underbrace{\Delta E_{\text{system}}}_{\substack{\text{Change in internal, kinetic,} \\ \text{potential, etc. energies}}} \\ -W_{b,\text{out}} = \Delta U = mc_v(T_2 - T_1)$$

The final temperature for the isentropic case is

$$T_{2s} = T_1 \left(\frac{P_2}{P_1} \right)^{(k-1)/k} = (600 \text{ R}) \left(\frac{20 \text{ psia}}{180 \text{ psia}} \right)^{0.4/1.4} = 320.3 \text{ R}$$

The actual exit temperature from the isentropic relation is

$$\eta = \frac{T_1 - T_2}{T_1 - T_{2s}} \\ T_2 = T_1 - \eta(T_1 - T_{2s}) = 600 - (0.95)(600 - 320.3) = 334.3 \text{ R}$$

The boundary work output is

$$w_{b,\text{out}} = c_v(T_1 - T_2) = (0.171 \text{ Btu/lbm}\cdot\text{R})(600 - 334.3) \text{ R} = 45.44 \text{ Btu/lbm}$$

The entropy change of air is

$$\Delta s_{\text{air}} = c_p \ln \frac{T_2}{T_1} - R \ln \frac{P_2}{P_1} \\ = (0.240 \text{ Btu/lbm}\cdot\text{R}) \ln \frac{334.3 \text{ R}}{600 \text{ R}} - (0.06855 \text{ Btu/lbm}\cdot\text{R}) \ln \frac{20 \text{ psia}}{180 \text{ psia}} \\ = 0.01021 \text{ Btu/lbm}\cdot\text{R}$$

The exergy difference between states 1 and 2 is

$$\phi_1 - \phi_2 = u_1 - u_2 + P_0(v_1 - v_2) - T_0(s_1 - s_2) \\ = c_v(T_1 - T_2) + P_0 R \left(\frac{T_1}{P_1} - \frac{T_2}{P_2} \right) - T_0(s_1 - s_2) \\ = 45.44 \text{ Btu/lbm} + (14.7 \text{ psia})(0.06855 \text{ Btu/lbm}\cdot\text{R}) \left(\frac{600 \text{ R}}{180 \text{ psia}} - \frac{334.3 \text{ R}}{20 \text{ psia}} \right) - (537 \text{ R})(-0.01021 \text{ Btu/lbm}\cdot\text{R}) \\ = 37.44 \text{ Btu/lbm}$$

The useful work is determined from

$$w_u = w_{b,\text{out}} - w_{\text{sur}} = c_v(T_1 - T_2) - P_0(v_2 - v_1) = c_v(T_1 - T_2) - P_0 R \left(\frac{T_2}{P_2} - \frac{T_1}{P_1} \right) \\ = 45.44 \text{ Btu/lbm} - (14.7 \text{ psia})(0.06855 \text{ Btu/lbm}\cdot\text{R}) \left(\frac{334.3 \text{ R}}{20 \text{ psia}} - \frac{600 \text{ R}}{180 \text{ psia}} \right) \\ = 31.96 \text{ Btu/lbm}$$

The second law efficiency is then

$$\eta_{\text{II}} = \frac{w_u}{\Delta\phi} = \frac{31.96 \text{ Btu/lbm}}{37.44 \text{ Btu/lbm}} = \mathbf{0.854}$$

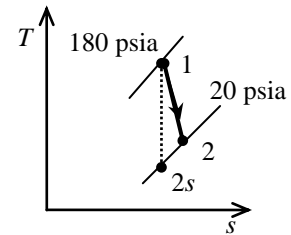
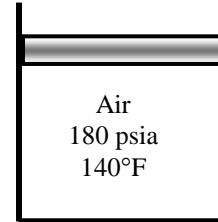

8-27E Air and helium at specified states are considered. The gas with the higher exergy content is to be identified.

Assumptions 1 Kinetic and potential energy changes are negligible. **2** Air and helium are ideal gases with constant specific heats.

Properties The properties of air at room temperature are $c_p = 0.240$ Btu/lbm·R, $c_v = 0.171$ Btu/lbm·R, $k = 1.4$, and $R = 0.06855$ Btu/lbm·R = 0.3704 psia·ft³/lbm·R. For helium, $c_p = 1.25$ Btu/lbm·R, $c_v = 0.753$ Btu/lbm·R, $k = 1.667$, and $R = 0.4961$ Btu/lbm·R = 2.6809 psia·ft³/lbm·R. (Table A-2E).

Analysis The mass of air in the system is

$$m = \frac{P\mathcal{V}}{RT} = \frac{(100 \text{ psia})(15 \text{ ft}^3)}{(0.3704 \text{ psia} \cdot \text{ft}^3/\text{lbm} \cdot \text{R})(710 \text{ R})} = 5.704 \text{ lbm}$$

Air 15 ft ³ 100 psia 250°F
--

The entropy change of air between the given state and the dead state is

$$\begin{aligned} s - s_0 &= c_p \ln \frac{T}{T_0} - R \ln \frac{P}{P_0} \\ &= (0.240 \text{ Btu/lbm} \cdot \text{R}) \ln \frac{710 \text{ R}}{537 \text{ R}} - (0.06855 \text{ Btu/lbm} \cdot \text{R}) \ln \frac{100 \text{ psia}}{14.7 \text{ psia}} \\ &= -0.06441 \text{ Btu/lbm} \cdot \text{R} \end{aligned}$$

The air's specific volumes at the given state and dead state are

$$\begin{aligned} \nu &= \frac{RT}{P} = \frac{(0.3704 \text{ psia} \cdot \text{ft}^3/\text{lbm} \cdot \text{R})(710 \text{ R})}{100 \text{ psia}} = 2.630 \text{ ft}^3/\text{lbm} \\ \nu_0 &= \frac{RT_0}{P_0} = \frac{(0.3704 \text{ psia} \cdot \text{ft}^3/\text{lbm} \cdot \text{R})(537 \text{ R})}{14.7 \text{ psia}} = 13.53 \text{ ft}^3/\text{lbm} \end{aligned}$$

The specific closed system exergy of the air is then

$$\begin{aligned} \phi &= u - u_0 + P_0(\nu - \nu_0) - T_0(s - s_0) \\ &= c_v(T - T_0) + P_0(\nu - \nu_0) - T_0(s - s_0) \\ &= (0.171 \text{ Btu/lbm} \cdot \text{R})(300 - 77)\text{R} + (14.7 \text{ psia})(2.630 - 13.53)\text{ft}^3/\text{lbm} \left(\frac{1 \text{ Btu}}{5.404 \text{ psia} \cdot \text{ft}^3} \right) \\ &\quad - (537 \text{ R})(-0.06441) \text{ Btu/lbm} \cdot \text{R} \\ &= 34.52 \text{ Btu/lbm} \end{aligned}$$

The total exergy available in the air for the production of work is then

$$\Phi = m\phi = (5.704 \text{ lbm})(34.52 \text{ Btu/lbm}) = \mathbf{197 \text{ Btu}}$$

We now repeat the calculations for helium:

$$m = \frac{P\mathcal{V}}{RT} = \frac{(60 \text{ psia})(20 \text{ ft}^3)}{(2.6809 \text{ psia} \cdot \text{ft}^3/\text{lbm} \cdot \text{R})(660 \text{ R})} = 0.6782 \text{ lbm}$$

Helium 20 ft ³ 60 psia 200°F
--

$$\begin{aligned} s - s_0 &= c_p \ln \frac{T}{T_0} - R \ln \frac{P}{P_0} \\ &= (1.25 \text{ Btu/lbm} \cdot \text{R}) \ln \frac{660 \text{ R}}{537 \text{ R}} - (0.4961 \text{ Btu/lbm} \cdot \text{R}) \ln \frac{60 \text{ psia}}{14.7 \text{ psia}} \\ &= -0.4400 \text{ Btu/lbm} \cdot \text{R} \end{aligned}$$

$$\nu = \frac{RT}{P} = \frac{(2.6809 \text{ psia} \cdot \text{ft}^3/\text{lbm} \cdot \text{R})(660 \text{ R})}{60 \text{ psia}} = 29.49 \text{ ft}^3/\text{lbm}$$

$$v_0 = \frac{RT_0}{P_0} = \frac{(2.6809 \text{ psia} \cdot \text{ft}^3/\text{lbm} \cdot \text{R})(537 \text{ R})}{14.7 \text{ psia}} = 97.93 \text{ ft}^3/\text{lbm}$$

$$\begin{aligned} \phi &= u - u_0 + P_0(v - v_0) - T_0(s - s_0) \\ &= c_v(T - T_0) + P_0(v - v_0) - T_0(s - s_0) \\ &= (0.753 \text{ Btu/lbm} \cdot \text{R})(200 - 77)\text{R} + (14.7 \text{ psia})(29.49 - 97.93)\text{ft}^3/\text{lbm} \left(\frac{1 \text{ Btu}}{5.404 \text{ psia} \cdot \text{ft}^3} \right) \\ &\quad - (537 \text{ R})(-0.4400) \text{ Btu/lbm} \cdot \text{R} \\ &= 142.7 \text{ Btu/lbm} \end{aligned}$$

$$\Phi = m\phi = (0.6782 \text{ lbm})(142.7 \text{ Btu/lbm}) = \mathbf{96.8 \text{ Btu}}$$

Comparison of two results shows that the air system has a greater potential for the production of work.

8-28 Steam and R-134a at the same states are considered. The fluid with the higher exergy content is to be identified.

Assumptions Kinetic and potential energy changes are negligible.

Analysis The properties of water at the given state and at the dead state are

$$\left. \begin{array}{l} P = 800 \text{ kPa} \\ T = 180^\circ\text{C} \end{array} \right\} \begin{array}{l} u = 2594.7 \text{ kJ/kg} \\ \nu = 0.24720 \text{ m}^3/\text{kg} \\ s = 6.7155 \text{ kJ/kg} \cdot \text{K} \end{array} \quad (\text{Table A - 6})$$

$$\left. \begin{array}{l} T_0 = 25^\circ\text{C} \\ P_0 = 100 \text{ kPa} \end{array} \right\} \begin{array}{l} u_0 \cong u_f @ 25^\circ\text{C} = 104.83 \text{ kJ/kg} \\ \nu_0 \cong \nu_f @ 25^\circ\text{C} = 0.001003 \text{ m}^3/\text{kg} \\ s_0 \cong s_f @ 25^\circ\text{C} = 0.3672 \text{ kJ/kg} \cdot \text{K} \end{array} \quad (\text{Table A - 4})$$

Steam
1 kg
800 kPa
180°C

The exergy of steam is

$$\begin{aligned} \Phi &= m[u - u_0 + P_0(\nu - \nu_0) - T_0(s - s_0)] \\ &= (1 \text{ kg}) \left[\begin{array}{l} (2594.7 - 104.83) \text{ kJ/kg} + (100 \text{ kPa})(0.24720 - 0.001003) \text{ m}^3/\text{kg} \left(\frac{1 \text{ kJ}}{1 \text{ kPa} \cdot \text{m}^3} \right) \\ - (298 \text{ K})(6.7155 - 0.3672) \text{ kJ/kg} \cdot \text{K} \end{array} \right] \\ &= \mathbf{622.7 \text{ kJ}} \end{aligned}$$

For R-134a;

$$\left. \begin{array}{l} P = 800 \text{ kPa} \\ T = 180^\circ\text{C} \end{array} \right\} \begin{array}{l} u = 386.99 \text{ kJ/kg} \\ \nu = 0.044554 \text{ m}^3/\text{kg} \\ s = 1.3327 \text{ kJ/kg} \cdot \text{K} \end{array} \quad (\text{Table A - 13})$$

$$\left. \begin{array}{l} T_0 = 25^\circ\text{C} \\ P_0 = 100 \text{ kPa} \end{array} \right\} \begin{array}{l} u_0 \cong u_f @ 25^\circ\text{C} = 85.85 \text{ kJ/kg} \\ \nu_0 \cong \nu_f @ 25^\circ\text{C} = 0.0008286 \text{ m}^3/\text{kg} \\ s_0 \cong s_f @ 25^\circ\text{C} = 0.32432 \text{ kJ/kg} \cdot \text{K} \end{array} \quad (\text{Table A - 11})$$

R-134a
1 kg
800 kPa
180°C

$$\begin{aligned} \Phi &= m[u - u_0 + P_0(\nu - \nu_0) - T_0(s - s_0)] \\ &= (1 \text{ kg}) \left[\begin{array}{l} (386.99 - 85.85) \text{ kJ/kg} + (100 \text{ kPa})(0.044554 - 0.0008286) \text{ m}^3/\text{kg} \left(\frac{1 \text{ kJ}}{1 \text{ kPa} \cdot \text{m}^3} \right) \\ - (298 \text{ K})(1.3327 - 0.32432) \text{ kJ/kg} \cdot \text{K} \end{array} \right] \\ &= \mathbf{5.02 \text{ kJ}} \end{aligned}$$

The steam can therefore has more work potential than the R-134a.

8-29 A cylinder is initially filled with R-134a at a specified state. The refrigerant is cooled and condensed at constant pressure. The exergy of the refrigerant at the initial and final states, and the exergy destroyed during this process are to be determined.

Assumptions The kinetic and potential energies are negligible.

Properties From the refrigerant tables (Tables A-11 through A-13),

$$P_1 = 0.7 \text{ MPa} \left\{ \begin{array}{l} v_1 = 0.034875 \text{ m}^3 / \text{kg} \\ u_1 = 274.03 \text{ kJ/kg} \\ s_1 = 1.0257 \text{ kJ/kg} \cdot \text{K} \end{array} \right.$$

$$P_2 = 0.7 \text{ MPa} \left\{ \begin{array}{l} v_2 \cong v_f @ 20^\circ\text{C} = 0.0008160 \text{ m}^3 / \text{kg} \\ u_2 \cong u_f @ 20^\circ\text{C} = 78.85 \text{ kJ/kg} \\ s_2 \cong s_f @ 20^\circ\text{C} = 0.30062 \text{ kJ/kg} \cdot \text{K} \end{array} \right.$$

$$P_0 = 0.1 \text{ MPa} \left\{ \begin{array}{l} v_0 = 0.23373 \text{ m}^3 / \text{kg} \\ u_0 = 248.81 \text{ kJ/kg} \\ s_0 = 1.0919 \text{ kJ/kg} \cdot \text{K} \end{array} \right.$$

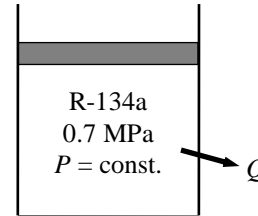

Analysis (a) From the closed system exergy relation,

$$\begin{aligned} X_1 &= \Phi_1 = m\{(u_1 - u_0) - T_0(s_1 - s_0) + P_0(v_1 - v_0)\} \\ &= (8 \text{ kg})\{(274.03 - 248.81) \text{ kJ/kg} - (293 \text{ K})(1.0257 - 1.0919) \text{ kJ/kg} \cdot \text{K} \\ &\quad + (100 \text{ kPa})(0.034875 - 0.23373) \text{ m}^3 / \text{kg} \left(\frac{1 \text{ kJ}}{1 \text{ kPa} \cdot \text{m}^3} \right)\} \\ &= \mathbf{197.8 \text{ kJ}} \end{aligned}$$

and

$$\begin{aligned} X_2 &= \Phi_2 = m\{(u_2 - u_0) - T_0(s_2 - s_0) + P_0(v_2 - v_0)\} \\ &= (8 \text{ kg})\{(78.85 - 248.81) \text{ kJ/kg} - (293 \text{ K})(0.30062 - 1.0919) \text{ kJ/kg} \cdot \text{K} \\ &\quad + (100 \text{ kPa})(0.0008160 - 0.23373) \text{ m}^3 / \text{kg} \left(\frac{1 \text{ kJ}}{1 \text{ kPa} \cdot \text{m}^3} \right)\} \\ &= \mathbf{308.6 \text{ kJ}} \end{aligned}$$

(b) The reversible work input, which represents the minimum work input $W_{\text{rev,in}}$ in this case can be determined from the exergy balance by setting the exergy destruction equal to zero,

$$\underbrace{X_{\text{in}} - X_{\text{out}}}_{\substack{\text{Net exergy transfer} \\ \text{by heat, work, and mass}}} - \underbrace{X_{\text{destroyed}}^{\neq 0 \text{ (reversible)}}}_{\substack{\text{Exergy} \\ \text{destruction}}} = \underbrace{\Delta X_{\text{system}}}_{\substack{\text{Change} \\ \text{in exergy}}} \\ W_{\text{rev,in}} = X_2 - X_1 = 308.6 - 197.8 = 110.8 \text{ kJ}$$

Noting that the process involves only boundary work, the useful work input during this process is simply the boundary work in excess of the work done by the surrounding air,

$$\begin{aligned} W_{\text{u,in}} &= W_{\text{in}} - W_{\text{sur,in}} = W_{\text{in}} - P_0(v_1 - v_2) = P(v_1 - v_2) - P_0m(v_1 - v_2) \\ &= m(P - P_0)(v_1 - v_2) \\ &= (8 \text{ kg})(700 - 100 \text{ kPa})(0.034875 - 0.0008160 \text{ m}^3 / \text{kg}) \left(\frac{1 \text{ kJ}}{1 \text{ kPa} \cdot \text{m}^3} \right) = 163.5 \text{ kJ} \end{aligned}$$

Knowing both the actual useful and reversible work inputs, the exergy destruction or irreversibility that is the difference between the two is determined from its definition to be

$$X_{\text{destroyed}} = I = W_{\text{u,in}} - W_{\text{rev,in}} = 163.5 - 110.8 = \mathbf{52.7 \text{ kJ}}$$

8-30 The radiator of a steam heating system is initially filled with superheated steam. The valves are closed, and steam is allowed to cool until the pressure drops to a specified value by transferring heat to the room. The amount of heat transfer to the room and the maximum amount of heat that can be supplied to the room are to be determined.

Assumptions Kinetic and potential energies are negligible.

Properties From the steam tables (Tables A-4 through A-6),

$$\begin{aligned}
 P_1 = 200 \text{ kPa} \quad & \left. \begin{aligned} \nu_1 &= 1.0805 \text{ m}^3 / \text{kg} \\ u_1 &= 2654.6 \text{ kJ/kg} \\ s_1 &= 7.5081 \text{ kJ/kg} \cdot \text{K} \end{aligned} \right\} \\
 T_1 = 200^\circ\text{C} & \\
 \\
 T_2 = 80^\circ\text{C} \quad & \left. \begin{aligned} x_2 &= \frac{\nu_2 - \nu_f}{\nu_{fg}} = \frac{1.0805 - 0.001029}{3.4053 - 0.001029} = 0.3171 \\ u_2 &= u_f + x_2 u_{fg} = 334.97 + 0.3171 \times 2146.6 = 1015.6 \text{ kJ/kg} \\ s_2 &= s_f + x_2 s_{fg} = 1.0756 + 0.3171 \times 6.5355 = 3.1479 \text{ kJ/kg} \cdot \text{K} \end{aligned} \right\} \\
 (\nu_2 = \nu_1) &
 \end{aligned}$$

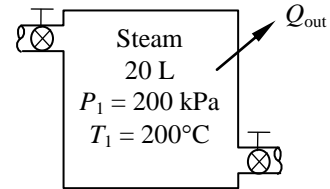

Analysis (a) The mass of the steam is

$$m = \frac{\nu}{\nu_1} = \frac{0.020 \text{ m}^3}{1.0805 \text{ m}^3 / \text{kg}} = 0.01851 \text{ kg}$$

The amount of heat transfer to the room is determined from an energy balance on the radiator expressed as

$$\begin{aligned}
 \underbrace{E_{\text{in}} - E_{\text{out}}}_{\text{Net energy transfer by heat, work, and mass}} &= \underbrace{\Delta E_{\text{system}}}_{\text{Change in internal, kinetic, potential, etc. energies}} \\
 -Q_{\text{out}} = \Delta U = m(u_2 - u_1) &\quad (\text{since } W = \text{KE} = \text{PE} = 0) \\
 Q_{\text{out}} = m(u_1 - u_2) &
 \end{aligned}$$

or
$$Q_{\text{out}} = (0.01851 \text{ kg})(2654.6 - 1015.6) \text{ kJ/kg} = \mathbf{30.3 \text{ kJ}}$$

(b) The reversible work output, which represents the maximum work output $W_{\text{rev,out}}$ in this case can be determined from the exergy balance by setting the exergy destruction equal to zero,

$$\begin{aligned}
 \underbrace{X_{\text{in}} - X_{\text{out}}}_{\text{Net exergy transfer by heat, work, and mass}} - \underbrace{X_{\text{destroyed}}^{\phi_0 \text{ (reversible)}}}_{\text{Exergy destruction}} &= \underbrace{\Delta X_{\text{system}}}_{\text{Change in exergy}} \\
 -W_{\text{rev,out}} = X_2 - X_1 &\rightarrow W_{\text{rev,out}} = X_1 - X_2 = \Phi_1 - \Phi_2
 \end{aligned}$$

Substituting the closed system exergy relation, the reversible work during this process is determined to be

$$\begin{aligned}
 W_{\text{rev,out}} &= m \left[(u_1 - u_2) - T_0 (s_1 - s_2) + P_0 (\nu_1^{\phi_0} - \nu_2) \right] \\
 &= m \left[(u_1 - u_2) - T_0 (s_1 - s_2) \right] \\
 &= (0.01851 \text{ kg}) \left[(2654.6 - 1015.6) \text{ kJ/kg} - (273 \text{ K})(7.5081 - 3.1479) \text{ kJ/kg} \cdot \text{K} \right] = 8.305 \text{ kJ}
 \end{aligned}$$

When this work is supplied to a reversible heat pump, it will supply the room heat in the amount of

$$Q_H = \text{COP}_{\text{HP,rev}} W_{\text{rev}} = \frac{W_{\text{rev}}}{1 - T_L / T_H} = \frac{8.305 \text{ kJ}}{1 - 273/294} = \mathbf{116 \text{ kJ}}$$

Discussion Note that the amount of heat supplied to the room can be increased by about 3 times by eliminating the irreversibility associated with the irreversible heat transfer process.



8-31 Problem 8-30 is reconsidered. The effect of the final steam temperature in the radiator on the amount of actual heat transfer and the maximum amount of heat that can be transferred is to be investigated.

Analysis The problem is solved using EES, and the solution is given below.

T_1=200 [C]
 P_1=200 [kPa]
 V=20 [L]
 T_2=80 [C]
 T_o=0 [C]
 P_o=100 [kPa]

"Conservation of energy for closed system is:"

E_in - E_out = DELTAE
 DELTAE = m*(u_2 - u_1)
 E_in=0
 E_out= Q_out
 u_1 =intenergy(steam_iapws,P=P_1,T=T_1)
 v_1 =volume(steam_iapws,P=P_1,T=T_1)
 s_1 =entropy(steam_iapws,P=P_1,T=T_1)
 v_2 = v_1
 u_2 = intenergy(steam_iapws, v=v_2,T=T_2)
 s_2 = entropy(steam_iapws, v=v_2,T=T_2)
 m=V*convert(L,m^3)/v_1
 W_rev=-m*(u_2 - u_1 -(T_o+273.15)*(s_2-s_1))+P_o*(v_1-v_2))

"When this work is supplied to a reversible heat pump, the heat pump will supply the room heat in the amount of ."

Q_H = COP_HP*W_rev
 COP_HP = T_H/(T_H-T_L)
 T_H = 294 [K]
 T_L = 273 [K]

Q _H [kJ]	Q _{out} [kJ]	T ₂ [C]	W _{rev} [kJ]
155.4	46.66	21	11.1
153.9	45.42	30	11
151.2	43.72	40	10.8
146.9	41.55	50	10.49
140.3	38.74	60	10.02
130.4	35.09	70	9.318
116.1	30.34	80	8.293

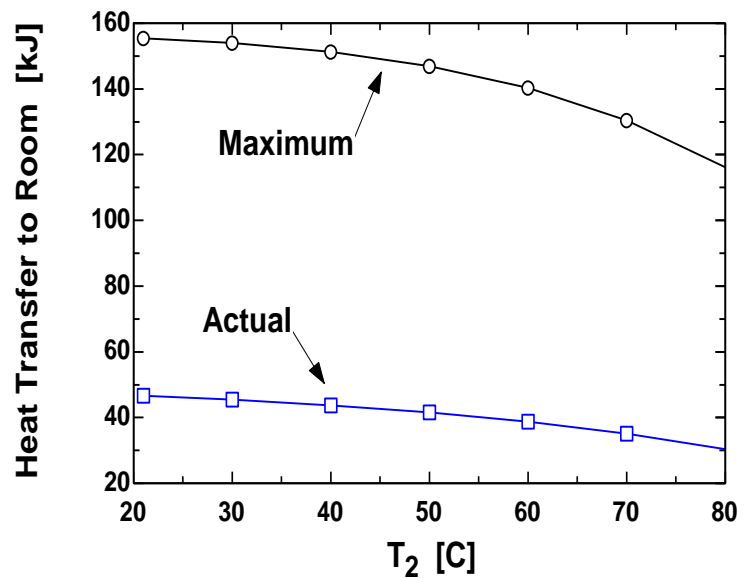

8-32E An insulated rigid tank contains saturated liquid-vapor mixture of water at a specified pressure. An electric heater inside is turned on and kept on until all the liquid is vaporized. The exergy destruction and the second-law efficiency are to be determined.

Assumptions Kinetic and potential energies are negligible.

Properties From the steam tables (Tables A-4 through A-6)

$$P_1 = 35 \text{ psia} \left\{ \begin{array}{l} v_1 = v_f + x_1 v_{fg} = 0.01708 + 0.25 \times (11.901 - 0.01708) = 2.9880 \text{ ft}^3 / \text{lbm} \\ u_1 = u_f + x_1 u_{fg} = 227.92 + 0.25 \times 862.19 = 443.47 \text{ Btu} / \text{lbm} \\ s_1 = s_f + x_1 s_{fg} = 0.38093 + 0.25 \times 1.30632 = 0.70751 \text{ Btu} / \text{lbm} \cdot \text{R} \end{array} \right.$$

$$\left. \begin{array}{l} v_2 = v_1 \\ \text{sat. vapor} \end{array} \right\} \begin{array}{l} u_2 = u_{g @ v_g = 2.9880 \text{ ft}^3 / \text{lbm}} = 1110.9 \text{ Btu} / \text{lbm} \\ s_2 = s_{g @ v_g = 2.9880 \text{ ft}^3 / \text{lbm}} = 1.5692 \text{ Btu} / \text{lbm} \cdot \text{R} \end{array}$$

Analysis (a) The irreversibility can be determined from its definition

$X_{\text{destroyed}} = T_0 S_{\text{gen}}$ where the entropy generation is determined from an entropy balance on the tank, which is an insulated closed system,

$$\underbrace{S_{\text{in}} - S_{\text{out}}}_{\text{Net entropy transfer by heat and mass}} + \underbrace{S_{\text{gen}}}_{\text{Entropy generation}} = \underbrace{\Delta S_{\text{system}}}_{\text{Change in entropy}}$$

$$S_{\text{gen}} = \Delta S_{\text{system}} = m(s_2 - s_1)$$

Substituting,

$$\begin{aligned} X_{\text{destroyed}} &= T_0 S_{\text{gen}} = m T_0 (s_2 - s_1) \\ &= (6 \text{ lbm})(535 \text{ R})(1.5692 - 0.70751) \text{ Btu} / \text{lbm} \cdot \text{R} = \mathbf{2766 \text{ Btu}} \end{aligned}$$

(b) Noting that $V = \text{constant}$ during this process, the W and W_u are identical and are determined from the energy balance on the closed system energy equation,

$$\underbrace{E_{\text{in}} - E_{\text{out}}}_{\text{Net energy transfer by heat, work, and mass}} = \underbrace{\Delta E_{\text{system}}}_{\text{Change in internal, kinetic, potential, etc. energies}}$$

$$W_{e,\text{in}} = \Delta U = m(u_2 - u_1)$$

or,

$$W_{e,\text{in}} = (6 \text{ lbm})(1110.9 - 443.47) \text{ Btu} / \text{lbm} = 4005 \text{ Btu}$$

Then the reversible work during this process and the second-law efficiency become

$$W_{\text{rev},\text{in}} = W_{u,\text{in}} - X_{\text{destroyed}} = 4005 - 2766 = 1239 \text{ Btu}$$

Thus,

$$\eta_{\text{II}} = \frac{W_{\text{rev}}}{W_u} = \frac{1239 \text{ Btu}}{4005 \text{ Btu}} = \mathbf{30.9\%}$$

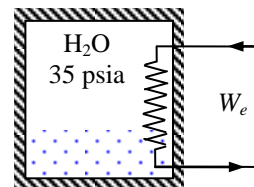

8-33 An insulated cylinder is initially filled with saturated liquid water at a specified pressure. The water is heated electrically at constant pressure. The minimum work by which this process can be accomplished and the exergy destroyed are to be determined.

Assumptions 1 The kinetic and potential energy changes are negligible. **2** The cylinder is well-insulated and thus heat transfer is negligible. **3** The thermal energy stored in the cylinder itself is negligible. **4** The compression or expansion process is quasi-equilibrium.

Analysis (a) From the steam tables (Tables A-4 through A-6),

$$\begin{aligned}
 u_1 &= u_f @ 120 \text{ kPa} = 439.27 \text{ kJ/kg} \\
 P_1 = 120 \text{ kPa} \left\{ \begin{aligned} v_1 &= v_f @ 120 \text{ kPa} = 0.001047 \text{ m}^3/\text{kg} \\ h_1 &= h_f @ 120 \text{ kPa} = 439.36 \text{ kJ/kg} \\ s_1 &= s_f @ 120 \text{ kPa} = 1.3609 \text{ kJ/kg} \cdot \text{K} \end{aligned} \right.
 \end{aligned}$$

The mass of the steam is

$$m = \frac{V}{v_1} = \frac{0.008 \text{ m}^3}{0.001047 \text{ m}^3/\text{kg}} = 7.639 \text{ kg}$$

We take the contents of the cylinder as the system. This is a closed system since no mass enters or leaves. The energy balance for this stationary closed system can be expressed as

$$\underbrace{E_{\text{in}} - E_{\text{out}}}_{\text{Net energy transfer by heat, work, and mass}} = \underbrace{\Delta E_{\text{system}}}_{\text{Change in internal, kinetic, potential, etc. energies}}$$

$$W_{e,\text{in}} - W_{b,\text{out}} = \Delta U$$

$$W_{e,\text{in}} = m(h_2 - h_1)$$

since $\Delta U + W_b = \Delta H$ during a constant pressure quasi-equilibrium process. Solving for h_2 ,

$$h_2 = h_1 + \frac{W_{e,\text{in}}}{m} = 439.36 + \frac{1400 \text{ kJ}}{7.639 \text{ kg}} = 622.63 \text{ kJ/kg}$$

Thus,

$$\begin{aligned}
 P_2 = 120 \text{ kPa} \left\{ \begin{aligned} x_2 &= \frac{h_2 - h_f}{h_{fg}} = \frac{622.63 - 439.36}{2243.7} = 0.08168 \\ s_2 &= s_f + x_2 s_{fg} = 1.3609 + 0.08168 \times 5.93687 = 1.8459 \text{ kJ/kg} \cdot \text{K} \\ u_2 &= u_f + x_2 u_{fg} = 439.24 + 0.08168 \times 2072.4 = 608.52 \text{ kJ/kg} \\ v_2 &= v_f + x_2 v_{fg} = 0.001047 + 0.08168 \times (1.4285 - 0.001047) = 0.1176 \text{ m}^3/\text{kg} \end{aligned} \right.
 \end{aligned}$$

The reversible work input, which represents the minimum work input $W_{\text{rev},\text{in}}$ in this case can be determined from the exergy balance by setting the exergy destruction equal to zero,

$$\underbrace{X_{\text{in}} - X_{\text{out}}}_{\text{Net exergy transfer by heat, work, and mass}} - \underbrace{X_{\text{destroyed}}}_{\text{Exergy destruction}} \stackrel{?0 \text{ (reversible)}}{=} \underbrace{\Delta X_{\text{system}}}_{\text{Change in exergy}} \rightarrow W_{\text{rev},\text{in}} = X_2 - X_1$$

Substituting the closed system exergy relation, the reversible work input during this process is determined to be

$$\begin{aligned}
 W_{\text{rev},\text{in}} &= -m[(u_1 - u_2) - T_0(s_1 - s_2) + P_0(v_1 - v_2)] \\
 &= -(7.639 \text{ kg})\{(439.27 - 608.52) \text{ kJ/kg} - (298 \text{ K})(1.3609 - 1.8459) \text{ kJ/kg} \cdot \text{K} \\
 &\quad + (100 \text{ kPa})(0.001047 - 0.1176) \text{ m}^3/\text{kg}[1 \text{ kJ}/1 \text{ kPa} \cdot \text{m}^3]\} \\
 &= \mathbf{278 \text{ kJ}}
 \end{aligned}$$

(b) The exergy destruction (or irreversibility) associated with this process can be determined from its definition $X_{\text{destroyed}} = T_0 S_{\text{gen}}$ where the entropy generation is determined from an entropy balance on the cylinder, which is an insulated closed system,

$$\underbrace{S_{\text{in}} - S_{\text{out}}}_{\text{Net entropy transfer by heat and mass}} + \underbrace{S_{\text{gen}}}_{\text{Entropy generation}} = \underbrace{\Delta S_{\text{system}}}_{\text{Change in entropy}}$$

$$S_{\text{gen}} = \Delta S_{\text{system}} = m(s_2 - s_1)$$

Substituting,

$$X_{\text{destroyed}} = T_0 S_{\text{gen}} = mT_0(s_2 - s_1) = (298 \text{ K})(7.639 \text{ kg})(1.8459 - 1.3609) \text{ kJ/kg} \cdot \text{K} = \mathbf{1104 \text{ kJ}}$$

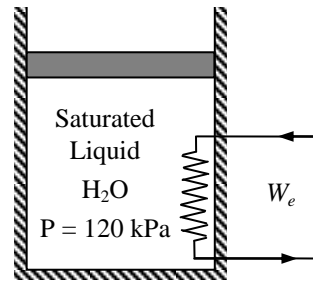



8-34 Problem 8-33 is reconsidered. The effect of the amount of electrical work on the minimum work and the exergy destroyed is to be investigated.

Analysis The problem is solved using EES, and the solution is given below.

```
x_1=0
P_1=120 [kPa]
V=8 [L]
P_2=P_1
{W_Ele = 1400 [kJ]}
T_o=25 [C]
P_o=100 [kPa]
```

"Conservation of energy for closed system is:"

```
E_in - E_out = DELTAE
DELTA E = m*(u_2 - u_1)
E_in=W_Ele
E_out= W_b
W_b = m*P_1*(v_2-v_1)
u_1 =intenergy(steam_iapws,P=P_1,x=x_1)
v_1 =volume(steam_iapws,P=P_1,x=x_1)
s_1 =entropy(steam_iapws,P=P_1,x=x_1)
u_2 = intenergy(steam_iapws, v=v_2,P=P_2)
s_2 = entropy(steam_iapws, v=v_2,P=P_2)
m=V*convert(L,m^3)/v_1
W_rev_in=m*(u_2 - u_1 -(T_o+273.15)
*(s_2-s_1)+P_o*(v_2-v_1))
```

"Entropy Balance:"

```
S_in - S_out+S_gen = DELTAS_sys
DELTA S_sys = m*(s_2 - s_1)
S_in=0 [kJ/K]
S_out= 0 [kJ/K]
```

"The exergy destruction or irreversibility is:"

```
X_destroyed = (T_o+273.15)*S_gen
```

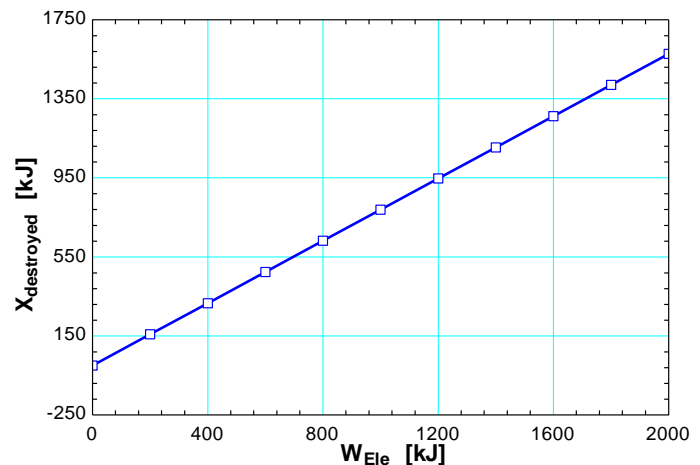

W _{Ele} [kJ]	W _{rev,in} [kJ]	X _{destroyed} [kJ]
0	0	0
200	39.68	157.8
400	79.35	315.6
600	119	473.3
800	158.7	631.1
1000	198.4	788.9
1200	238.1	946.7
1400	277.7	1104
1600	317.4	1262
1800	357.1	1420
2000	396.8	1578

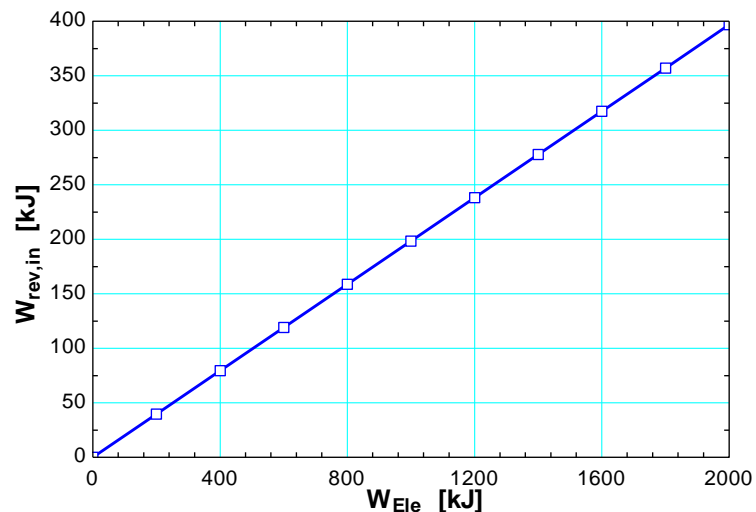

8-35 An insulated cylinder is initially filled with saturated R-134a vapor at a specified pressure. The refrigerant expands in a reversible manner until the pressure drops to a specified value. The change in the exergy of the refrigerant during this process and the reversible work are to be determined.

Assumptions 1 The kinetic and potential energy changes are negligible. **2** The cylinder is well-insulated and thus heat transfer is negligible. **3** The thermal energy stored in the cylinder itself is negligible. **4** The process is stated to be reversible.

Analysis This is a reversible adiabatic (i.e., isentropic) process, and thus $s_2 = s_1$. From the refrigerant tables (Tables A-11 through A-13),

$$P_1 = 0.6 \text{ MPa} \left. \begin{array}{l} \nu_1 = \nu_g @ 0.6 \text{ MPa} = 0.03433 \text{ m}^3 / \text{kg} \\ u_1 = u_g @ 0.6 \text{ MPa} = 241.86 \text{ kJ/kg} \\ s_1 = s_g @ 0.6 \text{ MPa} = 0.9220 \text{ kJ/kg} \cdot \text{K} \end{array} \right\} \text{ sat. vapor}$$

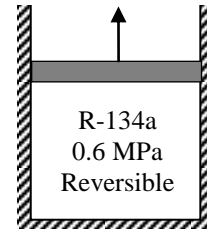

The mass of the refrigerant is

$$m = \frac{\nu}{\nu_1} = \frac{0.03 \text{ m}^3}{0.03433 \text{ m}^3 / \text{kg}} = 0.8738 \text{ kg}$$

$$P_2 = 0.16 \text{ MPa} \left. \begin{array}{l} x_2 = \frac{s_2 - s_f}{s_{fg}} = \frac{0.9220 - 0.12686}{0.81517} = 0.9754 \\ \nu_2 = \nu_f + x_2 \nu_{fg} = 0.0007435 + 0.9754(0.12355 - 0.0007435) = 0.12053 \text{ m}^3 / \text{kg} \\ u_2 = u_f + x_2 u_{fg} = 31.06 + 0.9754 \times 190.31 = 216.69 \text{ kJ/kg} \end{array} \right\} s_2 = s_1$$

The reversible work output, which represents the maximum work output $W_{\text{rev,out}}$ can be determined from the exergy balance by setting the exergy destruction equal to zero,

$$\underbrace{X_{\text{in}} - X_{\text{out}}}_{\text{Net exergy transfer by heat, work, and mass}} - \underbrace{X_{\text{destroyed}}}_{\text{Exergy destruction}} \stackrel{\neq 0 \text{ (reversible)}}{=} \underbrace{\Delta X_{\text{system}}}_{\text{Change in exergy}}$$

$$-W_{\text{rev,out}} = X_2 - X_1$$

$$W_{\text{rev,out}} = X_1 - X_2$$

$$= \Phi_1 - \Phi_2$$

Therefore, the change in exergy and the reversible work are identical in this case. Using the definition of the closed system exergy and substituting, the reversible work is determined to be

$$W_{\text{rev,out}} = \Phi_1 - \Phi_2 = m \left[(u_1 - u_2) - T_0 (s_1 - s_2) \right] + P_0 (\nu_1 - \nu_2) = m \left[(u_1 - u_2) + P_0 (\nu_1 - \nu_2) \right]$$

$$= (0.8738 \text{ kg}) [(241.86 - 216.69) \text{ kJ/kg} + (100 \text{ kPa})(0.03433 - 0.12053) \text{ m}^3 / \text{kg} [\text{kJ/kPa} \cdot \text{m}^3]]$$

$$= \mathbf{14.5 \text{ kJ}}$$

8-36E Oxygen gas is compressed from a specified initial state to a final specified state. The reversible work and the increase in the exergy of the oxygen during this process are to be determined.

Assumptions At specified conditions, oxygen can be treated as an ideal gas with constant specific heats.

Properties The gas constant of oxygen is $R = 0.06206 \text{ Btu/lbm}\cdot\text{R}$ (Table A-1E). The constant-volume specific heat of oxygen at the average temperature is

$$T_{\text{avg}} = (T_1 + T_2) / 2 = (75 + 525) / 2 = 300^\circ\text{F} \longrightarrow c_{v,\text{avg}} = 0.164 \text{ Btu/lbm}\cdot\text{R}$$

Analysis The entropy change of oxygen is

$$\begin{aligned} s_2 - s_1 &= c_{v,\text{avg}} \ln\left(\frac{T_2}{T_1}\right) + R \ln\left(\frac{v_2}{v_1}\right) \\ &= (0.164 \text{ Btu/lbm}\cdot\text{R}) \ln\left(\frac{985 \text{ R}}{535 \text{ R}}\right) + (0.06206 \text{ Btu/lbm}\cdot\text{R}) \ln\left(\frac{1.5 \text{ ft}^3/\text{lbm}}{12 \text{ ft}^3/\text{lbm}}\right) \\ &= -0.02894 \text{ Btu/lbm}\cdot\text{R} \end{aligned}$$

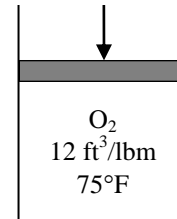

The reversible work input, which represents the minimum work input $W_{\text{rev,in}}$ in this case can be determined from the exergy balance by setting the exergy destruction equal to zero,

$$\underbrace{X_{\text{in}} - X_{\text{out}}}_{\text{Net exergy transfer by heat, work, and mass}} - \underbrace{X_{\text{destroyed}}}_{\substack{\text{Exergy} \\ \text{destruction}}} \stackrel{\text{reversible}}{=} \underbrace{\Delta X_{\text{system}}}_{\text{Change in exergy}} \rightarrow W_{\text{rev,in}} = X_2 - X_1$$

Therefore, the change in exergy and the reversible work are identical in this case. Substituting the closed system exergy relation, the reversible work input during this process is determined to be

$$\begin{aligned} w_{\text{rev,in}} &= \phi_2 - \phi_1 = -[(u_1 - u_2) - T_0(s_1 - s_2) + P_0(v_1 - v_2)] \\ &= -\{(0.164 \text{ Btu/lbm}\cdot\text{R})(535 - 985)\text{R} - (535 \text{ R})(0.02894 \text{ Btu/lbm}\cdot\text{R}) \\ &\quad + (14.7 \text{ psia})(12 - 1.5) \text{ ft}^3/\text{lbm} [\text{Btu}/5.4039 \text{ psia}\cdot\text{ft}^3]\} \\ &= \mathbf{60.7 \text{ Btu/lbm}} \end{aligned}$$

Also, the increase in the exergy of oxygen is

$$\phi_2 - \phi_1 = w_{\text{rev,in}} = \mathbf{60.7 \text{ Btu/lbm}}$$

8-37 A cylinder initially contains air at atmospheric conditions. Air is compressed to a specified state and the useful work input is measured. The exergy of the air at the initial and final states, and the minimum work input to accomplish this compression process, and the second-law efficiency are to be determined

Assumptions **1** Air is an ideal gas with constant specific heats. **2** The kinetic and potential energies are negligible.

Properties The gas constant of air is $R = 0.287 \text{ kPa}\cdot\text{m}^3/\text{kg}\cdot\text{K}$ (Table A-1). The specific heats of air at the average temperature of $(298+423)/2=360 \text{ K}$ are $c_p = 1.009 \text{ kJ/kg}\cdot\text{K}$ and $c_v = 0.722 \text{ kJ/kg}\cdot\text{K}$ (Table A-2).

Analysis (a) We realize that $X_1 = \Phi_1 = 0$ since air initially is at the dead state. The mass of air is

$$m = \frac{P_1 V_1}{RT_1} = \frac{(100 \text{ kPa})(0.002 \text{ m}^3)}{(0.287 \text{ kPa}\cdot\text{m}^3 / \text{kg}\cdot\text{K})(298 \text{ K})} = 0.00234 \text{ kg}$$

Also,

$$\frac{P_2 V_2}{T_2} = \frac{P_1 V_1}{T_1} \longrightarrow V_2 = \frac{P_1 T_2}{P_2 T_1} V_1 = \frac{(100 \text{ kPa})(423 \text{ K})}{(600 \text{ kPa})(298 \text{ K})} (2 \text{ L}) = 0.473 \text{ L}$$

and

$$\begin{aligned} s_2 - s_0 &= c_{p,\text{avg}} \ln \frac{T_2}{T_0} - R \ln \frac{P_2}{P_0} \\ &= (1.009 \text{ kJ/kg}\cdot\text{K}) \ln \frac{423 \text{ K}}{298 \text{ K}} - (0.287 \text{ kJ/kg}\cdot\text{K}) \ln \frac{600 \text{ kPa}}{100 \text{ kPa}} \\ &= -0.1608 \text{ kJ/kg}\cdot\text{K} \end{aligned}$$

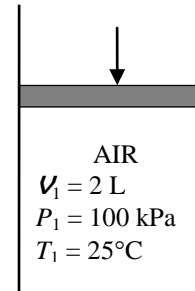

Thus, the exergy of air at the final state is

$$\begin{aligned} X_2 &= \Phi_2 = m [c_{v,\text{avg}}(T_2 - T_0) - T_0(s_2 - s_0)] + P_0(V_2 - V_0) \\ &= (0.00234 \text{ kg}) [(0.722 \text{ kJ/kg}\cdot\text{K})(423 - 298)\text{K} - (298 \text{ K})(-0.1608 \text{ kJ/kg}\cdot\text{K})] \\ &\quad + (100 \text{ kPa})(0.000473 - 0.002)\text{m}^3 [\text{kJ/m}^3 \cdot \text{kPa}] \\ &= \mathbf{0.171 \text{ kJ}} \end{aligned}$$

(b) The minimum work input is the reversible work input, which can be determined from the exergy balance by setting the exergy destruction equal to zero,

$$\begin{aligned} \underbrace{X_{\text{in}} - X_{\text{out}}}_{\text{Net exergy transfer by heat, work, and mass}} - \underbrace{X_{\text{destroyed}}}_{\text{Exergy destruction}} \stackrel{\approx 0 \text{ (reversible)}}{=} \underbrace{\Delta X_{\text{system}}}_{\text{Change in exergy}} \\ W_{\text{rev, in}} = X_2 - X_1 \\ = 0.171 - 0 = \mathbf{0.171 \text{ kJ}} \end{aligned}$$

(c) The second-law efficiency of this process is

$$\eta_{\text{II}} = \frac{W_{\text{rev, in}}}{W_{\text{u, in}}} = \frac{0.171 \text{ kJ}}{1.2 \text{ kJ}} = \mathbf{14.3\%}$$

8-38 An insulated tank contains CO₂ gas at a specified pressure and volume. A paddle-wheel in the tank stirs the gas, and the pressure and temperature of CO₂ rises. The actual paddle-wheel work and the minimum paddle-wheel work by which this process can be accomplished are to be determined.

Assumptions 1 At specified conditions, CO₂ can be treated as an ideal gas with constant specific heats at the average temperature. **2** The surroundings temperature is 298 K.

Properties The gas constant of CO₂ is 0.1889 kJ/kg·K (Table A-1)

Analysis (a) The initial and final temperature of CO₂ are

$$T_1 = \frac{P_1 V_1}{mR} = \frac{(100 \text{ kPa})(0.8 \text{ m}^3)}{(1.54 \text{ kg})(0.1889 \text{ kPa} \cdot \text{m}^3 / \text{kg} \cdot \text{K})} = 275.0 \text{ K}$$

$$T_2 = \frac{P_2 V_2}{mR} = \frac{(135 \text{ kPa})(0.8 \text{ m}^3)}{(1.54 \text{ kg})(0.1889 \text{ kPa} \cdot \text{m}^3 / \text{kg} \cdot \text{K})} = 371.3 \text{ K}$$

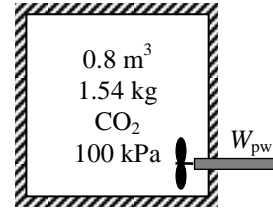

$$T_{\text{avg}} = (T_1 + T_2) / 2 = (275.0 + 371.3) / 2 = 323.1 \text{ K} \longrightarrow c_{v,\text{avg}} = 0.680 \text{ kJ/kg} \cdot \text{K} \text{ (Table A-2b)}$$

The actual paddle-wheel work done is determined from the energy balance on the CO₂ gas in the tank,

We take the contents of the cylinder as the system. This is a closed system since no mass enters or leaves. The energy balance for this stationary closed system can be expressed as

$$\underbrace{E_{\text{in}} - E_{\text{out}}}_{\substack{\text{Net energy transfer} \\ \text{by heat, work, and mass}}} = \underbrace{\Delta E_{\text{system}}}_{\substack{\text{Change in internal, kinetic,} \\ \text{potential, etc. energies}}}$$

$$W_{\text{pw,in}} = \Delta U = mc_v(T_2 - T_1)$$

or

$$W_{\text{pw,in}} = (1.54 \text{ kg})(0.680 \text{ kJ/kg} \cdot \text{K})(371.3 - 275.0) \text{ K} = \mathbf{100.8 \text{ kJ}}$$

(b) The minimum paddle-wheel work with which this process can be accomplished is the reversible work, which can be determined from the exergy balance by setting the exergy destruction equal to zero,

$$\underbrace{X_{\text{in}} - X_{\text{out}}}_{\substack{\text{Net exergy transfer} \\ \text{by heat, work, and mass}}} - \underbrace{X_{\text{destroyed}}}_{\substack{\text{Exergy} \\ \text{destruction}}} \stackrel{\text{reversible}}{=} \underbrace{\Delta X_{\text{system}}}_{\substack{\text{Change} \\ \text{in exergy}}} \rightarrow W_{\text{rev,in}} = X_2 - X_1$$

Substituting the closed system exergy relation, the reversible work input for this process is determined to be

$$W_{\text{rev,in}} = m \left[(u_2 - u_1) - T_0 (s_2 - s_1) + P_0 (v_2^{\text{sg}} - v_1) \right]$$

$$= m \left[c_{v,\text{avg}} (T_2 - T_1) - T_0 (s_2 - s_1) \right]$$

$$= (1.54 \text{ kg}) \left[(0.680 \text{ kJ/kg} \cdot \text{K})(371.3 - 275.0) \text{ K} - (298 \text{ K})(0.2041 \text{ kJ/kg} \cdot \text{K}) \right]$$

$$= \mathbf{7.18 \text{ kJ}}$$

since

$$s_2 - s_1 = c_{v,\text{avg}} \ln \frac{T_2}{T_1} + R \ln \frac{v_2}{v_1} \stackrel{\text{sg}}{\approx} = (0.680 \text{ kJ/kg} \cdot \text{K}) \ln \left(\frac{371.3 \text{ K}}{275.0 \text{ K}} \right) = 0.2041 \text{ kJ/kg} \cdot \text{K}$$

8-39 An insulated cylinder initially contains air at a specified state. A resistance heater inside the cylinder is turned on, and air is heated for 10 min at constant pressure. The exergy destruction during this process is to be determined.

Assumptions Air is an ideal gas with variable specific heats.

Properties The gas constant of air is $R = 0.287 \text{ kJ/kg}\cdot\text{K}$ (Table A-1).

Analysis The mass of the air and the electrical work done during this process are

$$m = \frac{P_1 V_1}{RT_1} = \frac{(140 \text{ kPa})(0.020 \text{ m}^3)}{(0.287 \text{ kPa}\cdot\text{m}^3/\text{kg}\cdot\text{K})(300 \text{ K})} = 0.03250 \text{ kg}$$

$$W_e = \dot{W}_e \Delta t = (0.100 \text{ kJ/s})(10 \times 60 \text{ s}) = 60 \text{ kJ}$$

Also,

$$T_1 = 300 \text{ K} \longrightarrow h_1 = 300.19 \text{ kJ/kg} \quad \text{and} \quad s_1^\circ = 1.70202 \text{ kJ/kg}\cdot\text{K}$$

The energy balance for this stationary closed system can be expressed as

$$\underbrace{E_{\text{in}} - E_{\text{out}}}_{\substack{\text{Net energy transfer} \\ \text{by heat, work, and mass}}} = \underbrace{\Delta E_{\text{system}}}_{\substack{\text{Change in internal, kinetic,} \\ \text{potential, etc. energies}}}$$

$$W_{e,\text{in}} - W_{b,\text{out}} = \Delta U$$

$$W_{e,\text{in}} = m(h_2 - h_1)$$

since $\Delta U + W_b = \Delta H$ during a constant pressure quasi-equilibrium process. Thus,

$$h_2 = h_1 + \frac{W_{e,\text{in}}}{m} = 300.19 + \frac{60 \text{ kJ}}{0.03250 \text{ kg}} = 2146.3 \text{ kJ/kg} \xrightarrow{\text{Table A-17}} \begin{matrix} T_2 = 1915 \text{ K} \\ s_2^\circ = 3.7452 \text{ kJ/kg}\cdot\text{K} \end{matrix}$$

Also,

$$s_2 - s_1 = s_2^\circ - s_1^\circ - R \ln \left(\frac{P_2}{P_1} \right)^{\neq 0} = s_2^\circ - s_1^\circ = 3.7452 - 1.70202 = 2.0432 \text{ kJ/kg}\cdot\text{K}$$

The exergy destruction (or irreversibility) associated with this process can be determined from its definition $X_{\text{destroyed}} = T_0 S_{\text{gen}}$ where the entropy generation is determined from an entropy balance on the cylinder, which is an insulated closed system,

$$\underbrace{S_{\text{in}} - S_{\text{out}}}_{\substack{\text{Net entropy transfer} \\ \text{by heat and mass}}} + \underbrace{S_{\text{gen}}}_{\substack{\text{Entropy} \\ \text{generation}}} = \underbrace{\Delta S_{\text{system}}}_{\substack{\text{Change} \\ \text{in entropy}}}$$

$$S_{\text{gen}} = \Delta S_{\text{system}} = m(s_2 - s_1)$$

Substituting,

$$X_{\text{destroyed}} = T_0 S_{\text{gen}} = mT_0(s_2 - s_1) = (0.03250 \text{ kg})(300 \text{ K})(2.0432 \text{ kJ/kg}\cdot\text{K}) = \mathbf{19.9 \text{ kJ}}$$

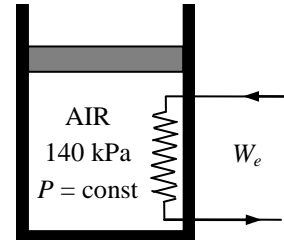

8-40 One side of a partitioned insulated rigid tank contains argon gas at a specified temperature and pressure while the other side is evacuated. The partition is removed, and the gas fills the entire tank. The exergy destroyed during this process is to be determined.

Assumptions Argon is an ideal gas with constant specific heats, and thus ideal gas relations apply.

Properties The gas constant of argon is $R = 0.2081 \text{ kJ/kg}\cdot\text{K}$ (Table A-1).

Analysis Taking the entire rigid tank as the system, the energy balance can be expressed as

$$\underbrace{E_{in} - E_{out}}_{\substack{\text{Net energy transfer} \\ \text{by heat, work, and mass}}} = \underbrace{\Delta E_{system}}_{\substack{\text{Change in internal, kinetic,} \\ \text{potential, etc. energies}}}$$

$$0 = \Delta U = m(u_2 - u_1)$$

$$u_2 = u_1 \rightarrow T_2 = T_1$$

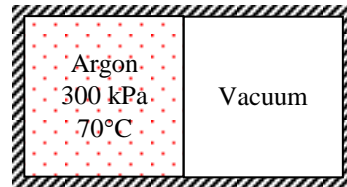

since $u = u(T)$ for an ideal gas.

The exergy destruction (or irreversibility) associated with this process can be determined from its definition $X_{\text{destroyed}} = T_0 S_{\text{gen}}$ where the entropy generation is determined from an entropy balance on the entire tank, which is an insulated closed system,

$$\underbrace{S_{in} - S_{out}}_{\substack{\text{Net entropy transfer} \\ \text{by heat and mass}}} + \underbrace{S_{gen}}_{\substack{\text{Entropy} \\ \text{generation}}} = \underbrace{\Delta S_{system}}_{\substack{\text{Change} \\ \text{in entropy}}}$$

$$S_{gen} = \Delta S_{system} = m(s_2 - s_1)$$

where

$$\Delta S_{system} = m(s_2 - s_1) = m \left(c_{v,avg} \ln \frac{T_2}{T_1} + R \ln \frac{v_2}{v_1} \right) = mR \ln \frac{v_2}{v_1}$$

$$= (3 \text{ kg})(0.2081 \text{ kJ/kg}\cdot\text{K}) \ln(2) = 0.433 \text{ kJ/K}$$

Substituting,

$$X_{\text{destroyed}} = T_0 S_{gen} = mT_0 (s_2 - s_1) = (298 \text{ K})(0.433 \text{ kJ/K}) = \mathbf{129 \text{ kJ}}$$

8-41E A hot copper block is dropped into water in an insulated tank. The final equilibrium temperature of the tank and the work potential wasted during this process are to be determined.

Assumptions 1 Both the water and the copper block are incompressible substances with constant specific heats at room temperature. **2** The system is stationary and thus the kinetic and potential energies are negligible. **3** The tank is well-insulated and thus there is no heat transfer.

Properties The density and specific heat of water at the anticipated average temperature of 90°F are $\rho = 62.1 \text{ lbm/ft}^3$ and $c_p = 1.00 \text{ Btu/lbm}\cdot^\circ\text{F}$. The specific heat of copper at the anticipated average temperature of 100°F is $c_p = 0.0925 \text{ Btu/lbm}\cdot^\circ\text{F}$ (Table A-3E).

Analysis (a) We take the entire contents of the tank, water + copper block, as the *system*, which is a closed system. The energy balance for this system can be expressed as

$$\underbrace{E_{\text{in}} - E_{\text{out}}}_{\substack{\text{Net energy transfer} \\ \text{by heat, work, and mass}}} = \underbrace{\Delta E_{\text{system}}}_{\substack{\text{Change in internal, kinetic,} \\ \text{potential, etc. energies}}} \\ 0 = \Delta U$$

or

$$\Delta U_{\text{Cu}} + \Delta U_{\text{water}} = 0$$

$$[mc(T_2 - T_1)]_{\text{Cu}} + [mc(T_2 - T_1)]_{\text{water}} = 0$$

where

$$m_w = \rho V = (62.1 \text{ lbm/ft}^3)(1.2 \text{ ft}^3) = 74.52 \text{ lbm}$$

Substituting,

$$0 = (70 \text{ lbm})(0.0925 \text{ Btu/lbm}\cdot^\circ\text{F})(T_2 - 220^\circ\text{F}) + (74.52 \text{ lbm})(1.0 \text{ Btu/lbm}\cdot^\circ\text{F})(T_2 - 65^\circ\text{F}) \\ T_2 = \mathbf{77.4^\circ\text{F}} = 537.4 \text{ R}$$



(b) The wasted work potential is equivalent to the exergy destruction (or irreversibility), and it can be determined from its definition $X_{\text{destroyed}} = T_0 S_{\text{gen}}$ where the entropy generation is determined from an entropy balance on the system, which is an insulated closed system,

$$\underbrace{S_{\text{in}} - S_{\text{out}}}_{\substack{\text{Net entropy transfer} \\ \text{by heat and mass}}} + \underbrace{S_{\text{gen}}}_{\substack{\text{Entropy} \\ \text{generation}}} = \underbrace{\Delta S_{\text{system}}}_{\substack{\text{Change} \\ \text{in entropy}}} \\ S_{\text{gen}} = \Delta S_{\text{system}} = \Delta S_{\text{water}} + \Delta S_{\text{copper}}$$

where

$$\Delta S_{\text{copper}} = mc_{\text{avg}} \ln \left(\frac{T_2}{T_1} \right) = (70 \text{ lbm})(0.0925 \text{ Btu/lbm}\cdot\text{R}) \ln \left(\frac{537.4 \text{ R}}{680 \text{ R}} \right) = -1.5240 \text{ Btu/R}$$

$$\Delta S_{\text{water}} = mc_{\text{avg}} \ln \left(\frac{T_2}{T_1} \right) = (74.52 \text{ lbm})(1.0 \text{ Btu/lbm}\cdot\text{R}) \ln \left(\frac{537.4 \text{ R}}{525 \text{ R}} \right) = 1.7384 \text{ Btu/R}$$

Substituting,

$$X_{\text{destroyed}} = (525 \text{ R})(-1.5240 + 1.7384) \text{ Btu/R} = \mathbf{113 \text{ Btu}}$$

8-42 A hot iron block is dropped into water in an insulated tank that is stirred by a paddle-wheel. The mass of the iron block and the exergy destroyed during this process are to be determined. \surd

Assumptions 1 Both the water and the iron block are incompressible substances with constant specific heats at room temperature. **2** The system is stationary and thus the kinetic and potential energies are negligible. **3** The tank is well-insulated and thus there is no heat transfer.

Properties The density and specific heat of water at 25°C are $\rho = 997 \text{ kg/m}^3$ and $c_p = 4.18 \text{ kJ/kg}\cdot^\circ\text{F}$. The specific heat of iron at room temperature (the only value available in the tables) is $c_p = 0.45 \text{ kJ/kg}\cdot^\circ\text{C}$ (Table A-3).

Analysis We take the entire contents of the tank, water + iron block, as the system, which is a closed system. The energy balance for this system can be expressed as

$$\underbrace{E_{\text{in}} - E_{\text{out}}}_{\substack{\text{Net energy transfer} \\ \text{by heat, work, and mass}}} = \underbrace{\Delta E_{\text{system}}}_{\substack{\text{Change in internal, kinetic,} \\ \text{potential, etc. energies}}}$$

$$W_{\text{pw,in}} = \Delta U = \Delta U_{\text{iron}} + \Delta U_{\text{water}}$$

$$W_{\text{pw,in}} = [mc(T_2 - T_1)]_{\text{iron}} + [mc(T_2 - T_1)]_{\text{water}}$$

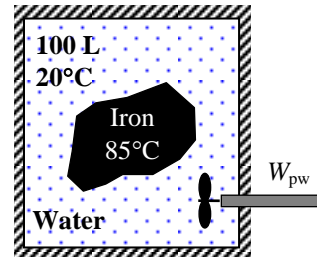

where

$$m_{\text{water}} = \rho V = (997 \text{ kg/m}^3)(0.1 \text{ m}^3) = 99.7 \text{ kg}$$

$$W_{\text{pw}} = \dot{W}_{\text{pw,in}} \Delta t = (0.2 \text{ kJ/s})(20 \times 60 \text{ s}) = 240 \text{ kJ}$$

Substituting,

$$240 \text{ kJ} = m_{\text{iron}}(0.45 \text{ kJ/kg}\cdot^\circ\text{C})(24 - 85)^\circ\text{C} + (99.7 \text{ kg})(4.18 \text{ kJ/kg}\cdot^\circ\text{C})(24 - 20)^\circ\text{C}$$

$$m_{\text{iron}} = \mathbf{52.0 \text{ kg}}$$

(b) The exergy destruction (or irreversibility) can be determined from its definition $X_{\text{destroyed}} = T_0 S_{\text{gen}}$ where the entropy generation is determined from an entropy balance on the system, which is an insulated closed system,

$$\underbrace{S_{\text{in}} - S_{\text{out}}}_{\substack{\text{Net entropy transfer} \\ \text{by heat and mass}}} + \underbrace{S_{\text{gen}}}_{\substack{\text{Entropy} \\ \text{generation}}} = \underbrace{\Delta S_{\text{system}}}_{\substack{\text{Change} \\ \text{in entropy}}}$$

$$S_{\text{gen}} = \Delta S_{\text{system}} = \Delta S_{\text{iron}} + \Delta S_{\text{water}}$$

where

$$\Delta S_{\text{iron}} = mc_{\text{avg}} \ln\left(\frac{T_2}{T_1}\right) = (52.0 \text{ kg})(0.45 \text{ kJ/kg}\cdot\text{K}) \ln\left(\frac{297 \text{ K}}{358 \text{ K}}\right) = -4.371 \text{ kJ/K}$$

$$\Delta S_{\text{water}} = mc_{\text{avg}} \ln\left(\frac{T_2}{T_1}\right) = (99.7 \text{ kg})(4.18 \text{ kJ/kg}\cdot\text{K}) \ln\left(\frac{297 \text{ K}}{293 \text{ K}}\right) = 5.651 \text{ kJ/K}$$

Substituting,

$$X_{\text{destroyed}} = T_0 S_{\text{gen}} = (293 \text{ K})(-4.371 + 5.651) \text{ kJ/K} = \mathbf{375.0 \text{ kJ}}$$

8-43E A rigid tank is initially filled with saturated mixture of R-134a. Heat is transferred to the tank from a source until the pressure inside rises to a specified value. The amount of heat transfer to the tank from the source and the exergy destroyed are to be determined.

Assumptions 1 The tank is stationary and thus the kinetic and potential energy changes are zero. **2** There is no heat transfer with the environment.

Properties From the refrigerant tables (Tables A-11E through A-13E),

$$\begin{aligned}
 \left. \begin{array}{l} P_1 = 30 \text{ psia} \\ x_1 = 0.55 \end{array} \right\} & \begin{array}{l} u_1 = u_f + x_1 u_{fg} = 16.929 + 0.55 \times 79.799 = 60.82 \text{ Btu/lbm} \\ s_1 = s_f + x_1 s_{fg} = 0.03792 + 0.55 \times 0.18595 = 0.1402 \text{ Btu/lbm} \cdot \text{R} \\ v_1 = v_f + x_1 v_{fg} = 0.01209 + 0.55 \times (1.5506 - 0.01209) = 0.85825 \text{ ft}^3/\text{lbm} \end{array} \\
 \left. \begin{array}{l} P_2 = 50 \text{ psia} \\ (v_2 = v_1) \end{array} \right\} & \begin{array}{l} x_2 = \frac{v_2 - v_f}{v_{fg}} = \frac{0.85825 - 0.01252}{0.79361 - 0.01252} = 0.9030 \\ s_2 = s_f + x_2 s_{fg} = 0.05412 + 0.9030 \times 0.16780 = 0.2056 \text{ Btu/lbm} \cdot \text{R} \\ u_2 = u_f + x_2 u_{fg} = 24.824 + 0.9030 \times 75.228 = 92.76 \text{ Btu/lbm} \end{array}
 \end{aligned}$$

Analysis (a) The mass of the refrigerant is

$$m = \frac{V}{v_1} = \frac{12 \text{ ft}^3}{0.85825 \text{ ft}^3/\text{lbm}} = 13.98 \text{ lbm}$$

We take the tank as the system, which is a closed system. The energy balance for this stationary closed system can be expressed as

$$\begin{aligned}
 \underbrace{E_{\text{in}} - E_{\text{out}}}_{\substack{\text{Net energy transfer} \\ \text{by heat, work, and mass}}} &= \underbrace{\Delta E_{\text{system}}}_{\substack{\text{Change in internal, kinetic,} \\ \text{potential, etc. energies}}} \\
 Q_{\text{in}} = \Delta U = m(u_2 - u_1)
 \end{aligned}$$

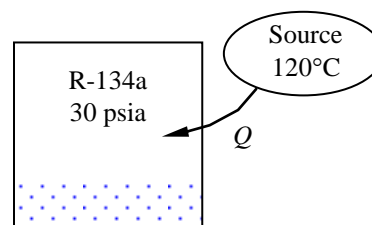

Substituting,

$$Q_{\text{in}} = m(u_2 - u_1) = (13.98 \text{ lbm})(92.76 - 60.82) \text{ Btu/lbm} = \mathbf{446.5 \text{ Btu}}$$

(b) The exergy destruction (or irreversibility) can be determined from its definition $X_{\text{destroyed}} = T_0 S_{\text{gen}}$. The entropy generation is determined from an entropy balance on an *extended system* that includes the tank and the region in its immediate surroundings so that the boundary temperature of the extended system where heat transfer occurs is the source temperature,

$$\begin{aligned}
 \underbrace{S_{\text{in}} - S_{\text{out}}}_{\substack{\text{Net entropy transfer} \\ \text{by heat and mass}}} + \underbrace{S_{\text{gen}}}_{\substack{\text{Entropy} \\ \text{generation}}} &= \underbrace{\Delta S_{\text{system}}}_{\substack{\text{Change} \\ \text{in entropy}}} \\
 \frac{Q_{\text{in}}}{T_{\text{b,in}}} + S_{\text{gen}} &= \Delta S_{\text{system}} = m(s_2 - s_1), \\
 S_{\text{gen}} &= m(s_2 - s_1) - \frac{Q_{\text{in}}}{T_{\text{source}}}
 \end{aligned}$$

Substituting,

$$X_{\text{destroyed}} = T_0 S_{\text{gen}} = (535 \text{ R}) \left[(13.98 \text{ lbm})(0.2056 - 0.1402) \text{ Btu/lbm} \cdot \text{R} - \frac{446.5 \text{ Btu}}{580 \text{ R}} \right] = \mathbf{77.8 \text{ Btu}}$$

8-44 Stainless steel ball bearings leaving the oven at a uniform temperature of 900°C at a rate of 1400 /min are exposed to air and are cooled to 850°C before they are dropped into the water for quenching. The rate of heat transfer from the ball to the air and the rate of exergy destruction due to this heat transfer are to be determined.

Assumptions 1 The thermal properties of the bearing balls are constant. **2** The kinetic and potential energy changes of the balls are negligible. **3** The balls are at a uniform temperature at the end of the process.

Properties The density and specific heat of the ball bearings are given to be $\rho = 8085 \text{ kg/m}^3$ and $c_p = 0.480 \text{ kJ/kg} \cdot \text{°C}$.

Analysis (a) We take a single bearing ball as the system. The energy balance for this closed system can be expressed as

$$\underbrace{E_{\text{in}} - E_{\text{out}}}_{\substack{\text{Net energy transfer} \\ \text{by heat, work, and mass}}} = \underbrace{\Delta E_{\text{system}}}_{\substack{\text{Change in internal, kinetic,} \\ \text{potential, etc. energies}}} \\ -Q_{\text{out}} = \Delta U_{\text{ball}} = m(u_2 - u_1) \\ Q_{\text{out}} = mc(T_1 - T_2)$$

The total amount of heat transfer from a ball is

$$m = \rho V = \rho \frac{\pi D^3}{6} = (8085 \text{ kg/m}^3) \frac{\pi (0.012 \text{ m})^3}{6} = 0.007315 \text{ kg} \\ Q_{\text{out}} = mc(T_1 - T_2) = (0.007315 \text{ kg})(0.480 \text{ kJ/kg} \cdot \text{°C})(900 - 850) \text{°C} = 0.1756 \text{ kJ/ball}$$

Then the rate of heat transfer from the balls to the air becomes

$$\dot{Q}_{\text{total}} = \dot{n}_{\text{ball}} Q_{\text{out(per ball)}} = (1400 \text{ balls/min}) \times (0.1756 \text{ kJ/ball}) = 245.8 \text{ kJ/min} = \mathbf{4.10 \text{ kW}}$$

Therefore, heat is lost to the air at a rate of 4.10 kW.

(b) The exergy destruction can be determined from its definition $X_{\text{destroyed}} = T_0 S_{\text{gen}}$. The entropy generated during this process can be determined by applying an entropy balance on an *extended system* that includes the ball and its immediate surroundings so that the boundary temperature of the extended system is at 30°C at all times:

$$\underbrace{S_{\text{in}} - S_{\text{out}}}_{\substack{\text{Net entropy transfer} \\ \text{by heat and mass}}} + \underbrace{S_{\text{gen}}}_{\substack{\text{Entropy} \\ \text{generation}}} = \underbrace{\Delta S_{\text{system}}}_{\substack{\text{Change} \\ \text{in entropy}}} \\ -\frac{Q_{\text{out}}}{T_b} + S_{\text{gen}} = \Delta S_{\text{system}} \rightarrow S_{\text{gen}} = \frac{Q_{\text{out}}}{T_b} + \Delta S_{\text{system}}$$

where

$$\Delta S_{\text{system}} = m(s_2 - s_1) = mc_{\text{avg}} \ln \frac{T_2}{T_1} = (0.007315 \text{ kg})(0.480 \text{ kJ/kg} \cdot \text{K}) \ln \frac{850 + 273}{900 + 273} = -0.0001530 \text{ kJ/K}$$

Substituting,

$$S_{\text{gen}} = \frac{Q_{\text{out}}}{T_b} + \Delta S_{\text{system}} = \frac{0.1756 \text{ kJ}}{303 \text{ K}} - 0.0001530 \text{ kJ/K} = 0.0004265 \text{ kJ/K (per ball)}$$

Then the rate of entropy generation becomes

$$\dot{S}_{\text{gen}} = S_{\text{gen}} \dot{n}_{\text{ball}} = (0.0004265 \text{ kJ/K} \cdot \text{ball})(1400 \text{ balls/min}) = 0.597 \text{ kJ/min} \cdot \text{K} = \mathbf{0.00995 \text{ kW/K}}$$

Finally,

$$\dot{X}_{\text{destroyed}} = T_0 \dot{S}_{\text{gen}} = (303 \text{ K})(0.00995 \text{ kW/K}) = \mathbf{3.01 \text{ kW/K}}$$

8-45 An egg is dropped into boiling water. The amount of heat transfer to the egg by the time it is cooked and the amount of exergy destruction associated with this heat transfer process are to be determined.

Assumptions 1 The egg is spherical in shape with a radius of $r_0 = 2.75$ cm. **2** The thermal properties of the egg are constant. **3** Energy absorption or release associated with any chemical and/or phase changes within the egg is negligible. **4** There are no changes in kinetic and potential energies. **5** The temperature of the surrounding medium is 25°C .

Properties The density and specific heat of the egg are given to be $\rho = 1020$ kg/m³ and $c_p = 3.32$ kJ/kg·°C.

Analysis We take the egg as the system. This is a closed system since no mass enters or leaves the egg. The energy balance for this closed system can be expressed as

$$\underbrace{E_{\text{in}} - E_{\text{out}}}_{\substack{\text{Net energy transfer} \\ \text{by heat, work, and mass}}} = \underbrace{\Delta E_{\text{system}}}_{\substack{\text{Change in internal, kinetic,} \\ \text{potential, etc. energies}}}$$

$$Q_{\text{in}} = \Delta U_{\text{egg}} = m(u_2 - u_1) = mc(T_2 - T_1)$$

Then the mass of the egg and the amount of heat transfer become

$$m = \rho V = \rho \frac{\pi D^3}{6} = (1020 \text{ kg/m}^3) \frac{\pi (0.055 \text{ m})^3}{6} = 0.0889 \text{ kg}$$

$$Q_{\text{in}} = mc_p (T_2 - T_1) = (0.0889 \text{ kg})(3.32 \text{ kJ/kg}\cdot^\circ\text{C})(70 - 8)^\circ\text{C} = \mathbf{18.3 \text{ kJ}}$$

The exergy destruction can be determined from its definition $X_{\text{destroyed}} = T_0 S_{\text{gen}}$. The entropy generated during this process can be determined by applying an entropy balance on an *extended system* that includes the egg and its immediate surroundings so that the boundary temperature of the extended system is at 97°C at all times:

$$\underbrace{S_{\text{in}} - S_{\text{out}}}_{\substack{\text{Net entropy transfer} \\ \text{by heat and mass}}} + \underbrace{S_{\text{gen}}}_{\substack{\text{Entropy} \\ \text{generation}}} = \underbrace{\Delta S_{\text{system}}}_{\substack{\text{Change} \\ \text{in entropy}}}$$

$$\frac{Q_{\text{in}}}{T_b} + S_{\text{gen}} = \Delta S_{\text{system}} \rightarrow S_{\text{gen}} = -\frac{Q_{\text{in}}}{T_b} + \Delta S_{\text{system}}$$

where

$$\Delta S_{\text{system}} = m(s_2 - s_1) = mc_{\text{avg}} \ln \frac{T_2}{T_1} = (0.0889 \text{ kg})(3.32 \text{ kJ/kg}\cdot\text{K}) \ln \frac{70 + 273}{8 + 273} = 0.0588 \text{ kJ/K}$$

Substituting,

$$S_{\text{gen}} = -\frac{Q_{\text{in}}}{T_b} + \Delta S_{\text{system}} = -\frac{18.3 \text{ kJ}}{370 \text{ K}} + 0.0588 \text{ kJ/K} = 0.00934 \text{ kJ/K (per egg)}$$

Finally,

$$X_{\text{destroyed}} = T_0 S_{\text{gen}} = (298 \text{ K})(0.00934 \text{ kJ/K}) = \mathbf{2.78 \text{ kJ}}$$

8-46 Chickens are to be cooled by chilled water in an immersion chiller that is also gaining heat from the surroundings. The rate of heat removal from the chicken and the rate of exergy destruction during this process are to be determined.

Assumptions 1 Steady operating conditions exist. **2** Thermal properties of chickens and water are constant. **3** The temperature of the surrounding medium is 25°C.

Properties The specific heat of chicken is given to be 3.54 kJ/kg·°C. The specific heat of water at room temperature is 4.18 kJ/kg·°C (Table A-3).

Analysis (a) Chickens are dropped into the chiller at a rate of 700 per hour. Therefore, chickens can be considered to flow steadily through the chiller at a mass flow rate of

$$\dot{m}_{\text{chicken}} = (700 \text{ chicken/h})(1.6 \text{ kg/chicken}) = 1120 \text{ kg/h} = 0.3111 \text{ kg/s}$$

Taking the chicken flow stream in the chiller as the system, the energy balance for steadily flowing chickens can be expressed in the rate form as

$$\underbrace{\dot{E}_{\text{in}} - \dot{E}_{\text{out}}}_{\text{Rate of net energy transfer by heat, work, and mass}} = \underbrace{\Delta \dot{E}_{\text{system}}}_{\text{Rate of change in internal, kinetic, potential, etc. energies}} \stackrel{\neq 0 \text{ (steady)}}{=} 0 \rightarrow \dot{E}_{\text{in}} = \dot{E}_{\text{out}}$$

$$\dot{m}h_1 = \dot{Q}_{\text{out}} + \dot{m}h_2 \quad (\text{since } \Delta \text{ke} \cong \Delta \text{pe} \cong 0)$$

$$\dot{Q}_{\text{out}} = \dot{Q}_{\text{chicken}} = \dot{m}_{\text{chicken}} c_p (T_1 - T_2)$$

Then the rate of heat removal from the chickens as they are cooled from 15°C to 3°C becomes

$$\dot{Q}_{\text{chicken}} = (\dot{m}c_p \Delta T)_{\text{chicken}} = (0.3111 \text{ kg/s})(3.54 \text{ kJ/kg}\cdot\text{°C})(15 - 3)\text{°C} = \mathbf{13.22 \text{ kW}}$$

The chiller gains heat from the surroundings as a rate of 200 kJ/h = 0.0556 kJ/s. Then the total rate of heat gain by the water is

$$\dot{Q}_{\text{water}} = \dot{Q}_{\text{chicken}} + \dot{Q}_{\text{heat gain}} = 13.22 \text{ kW} + (400/3600) \text{ kW} = 13.33 \text{ kW}$$

Noting that the temperature rise of water is not to exceed 2°C as it flows through the chiller, the mass flow rate of water must be at least

$$\dot{m}_{\text{water}} = \frac{\dot{Q}_{\text{water}}}{(c_p \Delta T)_{\text{water}}} = \frac{13.33 \text{ kW}}{(4.18 \text{ kJ/kg}\cdot\text{°C})(2\text{°C})} = 1.594 \text{ kg/s}$$

(b) The exergy destruction can be determined from its definition $X_{\text{destroyed}} = T_0 \dot{S}_{\text{gen}}$. The rate of entropy generation during this chilling process is determined by applying the rate form of the entropy balance on an *extended system* that includes the chiller and the immediate surroundings so that the boundary temperature is the surroundings temperature:

$$\underbrace{\dot{S}_{\text{in}} - \dot{S}_{\text{out}}}_{\text{Rate of net entropy transfer by heat and mass}} + \underbrace{\dot{S}_{\text{gen}}}_{\text{Rate of entropy generation}} = \underbrace{\Delta \dot{S}_{\text{system}}}_{\text{Rate of change of entropy}} \stackrel{\neq 0 \text{ (steady)}}{=} 0$$

$$\dot{m}_1 s_1 + \dot{m}_3 s_3 - \dot{m}_2 s_2 - \dot{m}_3 s_4 + \frac{\dot{Q}_{\text{in}}}{T_{\text{surr}}} + \dot{S}_{\text{gen}} = 0$$

$$\dot{m}_{\text{chicken}} s_1 + \dot{m}_{\text{water}} s_3 - \dot{m}_{\text{chicken}} s_2 - \dot{m}_{\text{water}} s_4 + \frac{\dot{Q}_{\text{in}}}{T_{\text{surr}}} + \dot{S}_{\text{gen}} = 0$$

$$\dot{S}_{\text{gen}} = \dot{m}_{\text{chicken}} (s_2 - s_1) + \dot{m}_{\text{water}} (s_4 - s_3) - \frac{\dot{Q}_{\text{in}}}{T_{\text{surr}}}$$

Noting that both streams are incompressible substances, the rate of entropy generation is determined to be

$$\dot{S}_{\text{gen}} = \dot{m}_{\text{chicken}} c_p \ln \frac{T_2}{T_1} + \dot{m}_{\text{water}} c_p \ln \frac{T_4}{T_3} - \frac{\dot{Q}_{\text{in}}}{T_{\text{surr}}}$$

$$= (0.3111 \text{ kg/s})(3.54 \text{ kJ/kg}\cdot\text{K}) \ln \frac{276}{288} + (1.594 \text{ kg/s})(4.18 \text{ kJ/kg}\cdot\text{K}) \ln \frac{275.5}{273.5} - \frac{(400/3600) \text{ kW}}{298 \text{ K}}$$

$$= 0.001306 \text{ kW/K}$$

Finally,

$$\dot{X}_{\text{destroyed}} = T_0 \dot{S}_{\text{gen}} = (298 \text{ K})(0.001306 \text{ kW/K}) = \mathbf{0.389 \text{ kW}}$$

8-47 Heat is transferred to a piston-cylinder device with a set of stops. The work done, the heat transfer, the exergy destroyed, and the second-law efficiency are to be determined.

Assumptions 1 The device is stationary and kinetic and potential energy changes are zero. **2** There is no friction between the piston and the cylinder. **3** Heat is transferred to the refrigerant from a source at 150°C.

Analysis (a) The properties of the refrigerant at the initial and final states are (Tables A-11 through A-13)

$$\left. \begin{array}{l} P_1 = 100 \text{ kPa} \\ T_1 = 20^\circ\text{C} \end{array} \right\} \begin{array}{l} \nu_1 = 0.23373 \text{ m}^3/\text{kg} \\ u_1 = 248.81 \text{ kJ/kg} \\ s_1 = 1.0919 \text{ kJ/kg}\cdot\text{K} \end{array}$$

$$\left. \begin{array}{l} P_2 = 120 \text{ kPa} \\ T_2 = 80^\circ\text{C} \end{array} \right\} \begin{array}{l} \nu_2 = 0.23669 \text{ m}^3/\text{kg} \\ u_2 = 296.94 \text{ kJ/kg} \\ s_2 = 1.2419 \text{ kJ/kg}\cdot\text{K} \end{array}$$

Noting that pressure remains constant at 120 kPa as the piston moves, the boundary work is determined to be

$$W_{b,\text{out}} = mP_2(\nu_2 - \nu_1) = (1.4 \text{ kg})(120 \text{ kPa})(0.23669 - 0.23373)\text{m}^3/\text{kg} = \mathbf{0.497 \text{ kJ}}$$

(b) The heat transfer can be determined from an energy balance on the system

$$Q_{\text{in}} = m(u_2 - u_1) + W_{b,\text{out}} = (1.4 \text{ kg})(296.94 - 248.81)\text{kJ/kg} + 0.497 \text{ kJ} = \mathbf{67.9 \text{ kJ}}$$

(c) The exergy destruction associated with this process can be determined from its definition $X_{\text{destroyed}} = T_0 S_{\text{gen}}$. The entropy generation is determined from an entropy balance on an *extended system* that includes the piston-cylinder device and the region in its immediate surroundings so that the boundary temperature of the extended system where heat transfer occurs is the source temperature,

$$\underbrace{S_{\text{in}} - S_{\text{out}}}_{\text{Net entropy transfer by heat and mass}} + \underbrace{S_{\text{gen}}}_{\text{Entropy generation}} = \underbrace{\Delta S_{\text{system}}}_{\text{Change in entropy}}$$

$$\frac{Q_{\text{in}}}{T_{b,\text{in}}} + S_{\text{gen}} = \Delta S_{\text{system}} = m(s_2 - s_1) \longrightarrow S_{\text{gen}} = m(s_2 - s_1) - \frac{Q_{\text{in}}}{T_{\text{source}}}$$

Substituting,

$$X_{\text{destroyed}} = T_0 S_{\text{gen}} = (298 \text{ K}) \left[(1.4 \text{ kg})(1.2419 - 1.0919)\text{kJ/kg}\cdot\text{K} - \frac{67.9 \text{ kJ}}{150 + 273 \text{ K}} \right] = \mathbf{14.8 \text{ kJ}}$$

(d) Exergy expended is the work potential of the heat extracted from the source at 150°C,

$$X_{\text{expended}} = X_Q = \eta_{\text{th,rev}} Q = \left(1 - \frac{T_L}{T_H} \right) Q = \left(1 - \frac{25 + 273 \text{ K}}{150 + 273 \text{ K}} \right) (67.9 \text{ kJ}) = 20.06 \text{ kJ}$$

Then the 2nd law efficiency becomes

$$\eta_{\text{II}} = \frac{X_{\text{recovered}}}{X_{\text{expended}}} = 1 - \frac{X_{\text{destroyed}}}{X_{\text{expended}}} = 1 - \frac{14.80 \text{ kJ}}{20.06 \text{ kJ}} = 0.262 \text{ or } \mathbf{26.2\%}$$

Discussion The second-law efficiency can also be determined as follows:

The exergy increase of the refrigerant is the exergy difference between the initial and final states,

$$\begin{aligned} \Delta X &= m[u_2 - u_1 - T_0(s_2 - s_1) + P_0(\nu_2 - \nu_1)] \\ &= (1.4 \text{ kg}) \left[(296.94 - 248.81)\text{kJ/kg} - (298 \text{ K})(1.2419 - 1.0919)\text{kJ/kg}\cdot\text{K} + (100 \text{ kPa})(0.23669 - 0.23373)\text{m}^3/\text{kg} \right] \\ &= 5.177 \text{ kJ} \end{aligned}$$

The useful work output for the process is

$$W_{u,\text{out}} = W_{b,\text{out}} - mP_0(\nu_2 - \nu_1) = 0.497 \text{ kJ} - (1.4 \text{ kg})(100 \text{ kPa})(0.23669 - 0.23373)\text{m}^3/\text{kg} = 0.0828 \text{ kJ}$$

The exergy recovered is the sum of the exergy increase of the refrigerant and the useful work output,

$$X_{\text{recovered}} = \Delta X + W_{u,\text{out}} = 5.177 + 0.0828 = 5.260 \text{ kJ}$$

Then the second-law efficiency becomes

$$\eta_{\text{II}} = \frac{X_{\text{recovered}}}{X_{\text{expended}}} = \frac{5.260 \text{ kJ}}{20.06 \text{ kJ}} = 0.262 \text{ or } \mathbf{26.2\%}$$

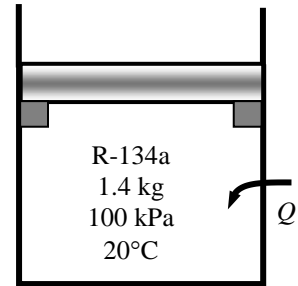

Exergy Analysis of Control Volumes

8-48 Refrigerant-124a is throttled from a specified state to a specified pressure. The reversible work and the exergy destroyed during this process are to be determined.

Assumptions 1 This is a steady-flow process since there is no change with time. **2** Kinetic and potential energy changes are negligible. **3** Heat transfer is negligible.

Properties The properties of R-134a before and after the throttling process are (Tables A-11 through A-13)

$$\left. \begin{array}{l} P_1 = 1 \text{ MPa} \\ T_1 = 100^\circ\text{C} \end{array} \right\} \begin{array}{l} h_1 = 335.08 \text{ kJ/kg} \\ s_1 = 1.1032 \text{ kJ/kg} \cdot \text{K} \end{array}$$

$$\left. \begin{array}{l} P_2 = 0.8 \text{ MPa} \\ h_2 = h_1 \end{array} \right\} s_2 = 1.1199 \text{ kJ/kg} \cdot \text{K}$$

Analysis The exergy destruction (or irreversibility) can be determined from an exergy balance or directly from its definition $X_{\text{destroyed}} = T_0 S_{\text{gen}}$ where the entropy generation is determined from an entropy balance on the system, which is an adiabatic steady-flow device,

$$\underbrace{\dot{S}_{\text{in}} - \dot{S}_{\text{out}}}_{\text{Rate of net entropy transfer by heat and mass}} + \underbrace{\dot{S}_{\text{gen}}}_{\text{Rate of entropy generation}} = \underbrace{\Delta \dot{S}_{\text{system}}}_{\text{Rate of change of entropy}} \stackrel{\phi_0}{=} 0$$

$$\dot{m}s_1 - \dot{m}s_2 + \dot{S}_{\text{gen}} = 0 \rightarrow \dot{S}_{\text{gen}} = \dot{m}(s_2 - s_1) \quad \text{or} \quad s_{\text{gen}} = s_2 - s_1$$

Substituting,

$$x_{\text{destroyed}} = T_0 s_{\text{gen}} = T_0 (s_2 - s_1) = (303 \text{ K})(1.1199 - 1.1032) \text{ kJ/kg} \cdot \text{K} = \mathbf{5.05 \text{ kJ/kg}}$$

This process involves no actual work, and thus the reversible work and irreversibility are identical,

$$x_{\text{destroyed}} = w_{\text{rev,out}} - w_{\text{act,out}} \stackrel{\phi_0}{=} \rightarrow w_{\text{rev,out}} = x_{\text{destroyed}} = \mathbf{5.05 \text{ kJ/kg}}$$

Discussion Note that 5.05 kJ/kg of work potential is wasted during this throttling process.

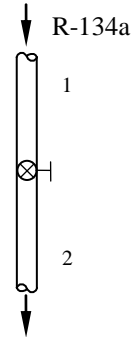



8-49 Problem 8-48 is reconsidered. The effect of exit pressure on the reversible work and exergy destruction is to be investigated.

Analysis The problem is solved using EES, and the solution is given below.

```

T_1=100"[C]"
P_1=1000"[kPa]"
{P_2=800"[kPa]"}
T_o=298"[K]"
"Steady-flow conservation of mass"
"m_dot_in = m_dot_out"
"Conservation of energy for steady-flow per unit mass is:"
e_in - e_out = DELTAe
DELTAe = 0"[kJ/kg]"
E_in=h_1"[kJ/kg]"
E_out= h_2 "[kJ/kg]"
h_1 =enthalpy(R134a,T=T_1,P=P_1) "[kJ/kg]"
T_2 = temperature(R134a, P=P_2,h=h_2) "[C]"
"Irreversibility, entropy generated, and exergy destroyed:"
s_1=entropy(R134a, T=T_1,P=P_1)"[kJ/kg-K]"
s_2=entropy(R134a,P=P_2,h=h_2)"[kJ/kg-K]"
I=T_o*s_gen"[kJ/kg]" "Irreversibility for the Process, kJ/kg"
s_gen=s_2-s_1"[kJ/kg-K]" "Entropy generated, kW"
x_destroyed = I"[kJ/kg]"
w_rev_out=x_destroyed"[kJ/kg]"

```

P ₂ [kPa]	w _{rev,out} [kJ/kg]	x _{destroyed} [kJ/kg]
100	53.82	53.82
200	37.22	37.22
300	27.61	27.61
400	20.86	20.86
500	15.68	15.68
600	11.48	11.48
700	7.972	7.972
800	4.961	4.961
900	2.33	2.33
1000	-4.325E-10	-4.325E-10

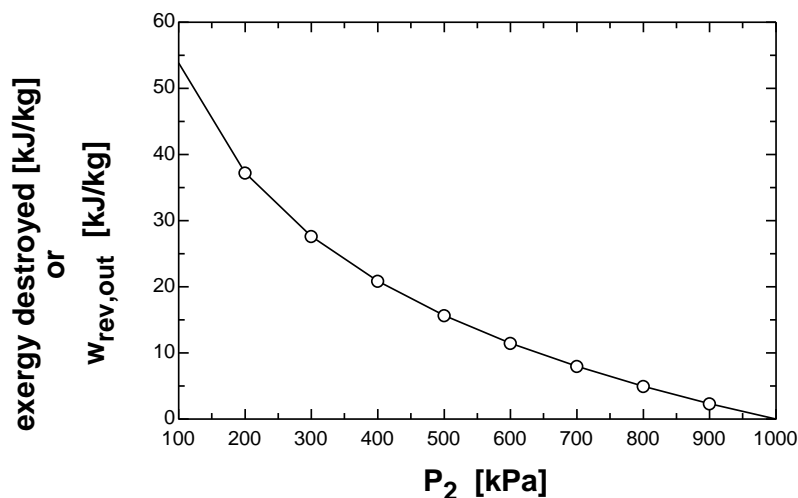

8-50 Helium expands in an adiabatic turbine from a specified inlet state to a specified exit state. The maximum work output is to be determined.

Assumptions 1 This is a steady-flow process since there is no change with time. **2** The device is adiabatic and thus heat transfer is negligible. **3** Helium is an ideal gas. **4** Kinetic and potential energy changes are negligible.

Properties The properties of helium are $c_p = 5.1926 \text{ kJ/kg}\cdot\text{K}$ and $R = 2.0769 \text{ kJ/kg}\cdot\text{K}$ (Table A-1).

Analysis The entropy change of helium is

$$\begin{aligned} s_2 - s_1 &= c_p \ln \frac{T_2}{T_1} - R \ln \frac{P_2}{P_1} \\ &= (5.1926 \text{ kJ/kg}\cdot\text{K}) \ln \frac{298 \text{ K}}{573 \text{ K}} - (2.0769 \text{ kJ/kg}\cdot\text{K}) \ln \frac{100 \text{ kPa}}{1500 \text{ kPa}} \\ &= 2.2295 \text{ kJ/kg}\cdot\text{K} \end{aligned}$$

The maximum (reversible) work is the exergy difference between the inlet and exit states

$$\begin{aligned} w_{\text{rev,out}} &= h_1 - h_2 - T_0(s_1 - s_2) \\ &= c_p(T_1 - T_2) - T_0(s_1 - s_2) \\ &= (5.1926 \text{ kJ/kg}\cdot\text{K})(300 - 25)\text{K} - (298 \text{ K})(-2.2295 \text{ kJ/kg}\cdot\text{K}) \\ &= \mathbf{2092 \text{ kJ/kg}} \end{aligned}$$

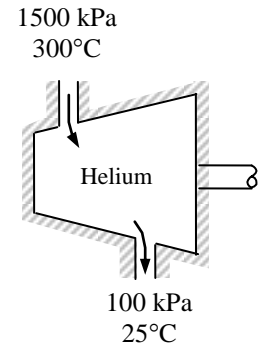

There is only one inlet and one exit, and thus $\dot{m}_1 = \dot{m}_2 = \dot{m}$. We take the turbine as the system, which is a control volume since mass crosses the boundary. The energy balance for this steady-flow system can be expressed in the rate form as

$$\begin{aligned} \underbrace{\dot{E}_{\text{in}} - \dot{E}_{\text{out}}}_{\text{Rate of net energy transfer by heat, work, and mass}} &= \underbrace{\dot{\Delta E}_{\text{system}}}_{\text{Rate of change in internal, kinetic, potential, etc. energies}} \stackrel{\text{no (steady)}}{=} 0 \\ \dot{E}_{\text{in}} &= \dot{E}_{\text{out}} \\ \dot{m}h_1 &= \dot{W}_{\text{out}} + \dot{Q}_{\text{out}} + \dot{m}h_2 \\ \dot{W}_{\text{out}} &= \dot{m}(h_1 - h_2) - \dot{Q}_{\text{out}} \\ w_{\text{out}} &= (h_1 - h_2) - q_{\text{out}} \end{aligned}$$

Inspection of this result reveals that any rejection of heat will decrease the work that will be produced by the turbine since inlet and exit states (i.e., enthalpies) are fixed.

If there is heat loss from the turbine, the maximum work output is determined from the rate form of the exergy balance applied on the turbine and setting the exergy destruction term equal to zero,

$$\begin{aligned} \underbrace{\dot{X}_{\text{in}} - \dot{X}_{\text{out}}}_{\text{Rate of net exergy transfer by heat, work, and mass}} - \underbrace{\dot{X}_{\text{destroyed}}}_{\text{Rate of exergy destruction}} \stackrel{\text{no (reversible)}}{=} \underbrace{\dot{\Delta X}_{\text{system}}}_{\text{Rate of change of exergy}} \stackrel{\text{no (steady)}}{=} 0 \\ \dot{X}_{\text{in}} &= \dot{X}_{\text{out}} \\ \dot{m}\psi_1 &= \dot{W}_{\text{rev,out}} + \dot{Q}_{\text{out}} \left(1 - \frac{T_0}{T} \right) + \dot{m}\psi_2 \\ w_{\text{rev,out}} &= (\psi_1 - \psi_2) - q_{\text{out}} \left(1 - \frac{T_0}{T} \right) \\ &= (h_1 - h_2) - T_0(s_1 - s_2) - q_{\text{out}} \left(1 - \frac{T_0}{T} \right) \end{aligned}$$

Inspection of this result reveals that any rejection of heat will decrease the maximum work that could be produced by the turbine. Therefore, for the maximum work, the turbine must be adiabatic.

8-51  Air is compressed steadily by an 8-kW compressor from a specified state to another specified state. The increase in the exergy of air and the rate of exergy destruction are to be determined.

Assumptions 1 Air is an ideal gas with variable specific heats. **2** Kinetic and potential energy changes are negligible.

Properties The gas constant of air is $R = 0.287 \text{ kJ/kg}\cdot\text{K}$ (Table A-1). From the air table (Table A-17)

$$\begin{aligned} T_1 = 290 \text{ K} &\longrightarrow h_1 = 290.16 \text{ kJ/kg} \\ & s_1^{\circ} = 1.66802 \text{ kJ/kg}\cdot\text{K} \\ T_2 = 440 \text{ K} &\longrightarrow h_2 = 441.61 \text{ kJ/kg} \\ & s_2^{\circ} = 2.0887 \text{ kJ/kg}\cdot\text{K} \end{aligned}$$

Analysis The increase in exergy is the difference between the exit and inlet flow exergies,

$$\begin{aligned} \text{Increase in exergy} &= \psi_2 - \psi_1 \\ &= [(h_2 - h_1) + \Delta ke^{\phi^0} + \Delta pe^{\phi^0} - T_0(s_2 - s_1)] \\ &= (h_2 - h_1) - T_0(s_2 - s_1) \end{aligned}$$

where

$$\begin{aligned} s_2 - s_1 &= (s_2^{\circ} - s_1^{\circ}) - R \ln \frac{P_2}{P_1} \\ &= (2.0887 - 1.66802) \text{ kJ/kg}\cdot\text{K} - (0.287 \text{ kJ/kg}\cdot\text{K}) \ln \frac{600 \text{ kPa}}{100 \text{ kPa}} \\ &= -0.09356 \text{ kJ/kg}\cdot\text{K} \end{aligned}$$

Substituting,

$$\begin{aligned} \text{Increase in exergy} &= \psi_2 - \psi_1 \\ &= [(441.61 - 290.16) \text{ kJ/kg} - (290 \text{ K})(-0.09356 \text{ kJ/kg}\cdot\text{K})] \\ &= \mathbf{178.6 \text{ kJ/kg}} \end{aligned}$$

Then the reversible power input is

$$\dot{W}_{\text{rev.in}} = \dot{m}(\psi_2 - \psi_1) = (2.1/60 \text{ kg/s})(178.6 \text{ kJ/kg}) = 6.25 \text{ kW}$$

(b) The rate of exergy destruction (or irreversibility) is determined from its definition,

$$\dot{X}_{\text{destroyed}} = \dot{W}_{\text{in}} - \dot{W}_{\text{rev.in}} = 8 - 6.25 = \mathbf{1.75 \text{ kW}}$$

Discussion Note that 1.75 kW of power input is wasted during this compression process.

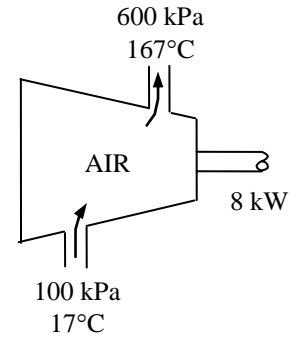



8-52 Problem 8-51 is reconsidered. The problem is to be solved and the actual heat transfer, its direction, the minimum power input, and the compressor second-law efficiency are to be determined.

Analysis The problem is solved using EES, and the solution is given below.

```

Function Direction$(Q)
If Q<0 then Direction$='out' else Direction$='in'
end
Function Violation$(eta)
If eta>1 then Violation$='You have violated the 2nd Law!!!!' else Violation$=""
end

{"Input Data from the Diagram Window"}
T_1=17 [C]
P_1=100 [kPa]
W_dot_c = 8 [kW]
P_2=600 [kPa]
S_dot_gen=0
Q_dot_net=0}
{"Special cases"}
T_2=167 [C]
m_dot=2.1 [kg/min]}
T_o=T_1
P_o=P_1
m_dot_in=m_dot*Convert(kg/min, kg/s)
"Steady-flow conservation of mass"
m_dot_in = m_dot_out
"Conservation of energy for steady-flow is:"
E_dot_in - E_dot_out = DELTAE_dot
DELTAE_dot = 0
E_dot_in=Q_dot_net + m_dot_in*h_1 +W_dot_c
"If Q_dot_net < 0, heat is transferred from the compressor"
E_dot_out= m_dot_out*h_2
h_1 =enthalpy(air,T=T_1)
h_2 = enthalpy(air, T=T_2)
W_dot_net=-W_dot_c
W_dot_rev=-m_dot_in*(h_2 - h_1 -(T_1+273.15)*(s_2-s_1))
"Irreversibility, entropy generated, second law efficiency, and exergy destroyed:"
s_1=entropy(air, T=T_1,P=P_1)
s_2=entropy(air,T=T_2,P=P_2)
s_2s=entropy(air,T=T_2s,P=P_2)
s_2s=s_1"This yields the isentropic T_2s for an isentropic process bewteen T_1, P_1 and
P_2"i_dot=(T_o+273.15)*S_dot_gen"Irreversibility for the Process, kW"
S_dot_gen=(-Q_dot_net/(T_o+273.15) +m_dot_in*(s_2-s_1)) "Entropy generated, kW"
Eta_II=W_dot_rev/W_dot_net"Definition of compressor second law efficiency, Eq. 7_6"
h_o=enthalpy(air,T=T_o)
s_o=entropy(air,T=T_o,P=P_o)
Psi_in=h_1-h_o-(T_o+273.15)*(s_1-s_o) "availability function at state 1"
Psi_out=h_2-h_o-(T_o+273.15)*(s_2-s_o) "availability function at state 2"
X_dot_in=Psi_in*m_dot_in
X_dot_out=Psi_out*m_dot_out
DELTA_X_dot=X_dot_in-X_dot_out
"General Exergy balance for a steady-flow system, Eq. 7-47"
(1-(T_o+273.15)/(T_o+273.15))*Q_dot_net-W_dot_net+m_dot_in*Psi_in - m_dot_out*Psi_out =X_dot_dest
"For the Diagram Window"
Text$=Direction$(Q_dot_net)
Text2$=Violation$(Eta_II)

```

η_{II}	I [kW]	\dot{X}_{dest} [kW]	T_{2s} [C]	T_2 [C]	\dot{Q}_{net} [kW]
0.7815	1.748	1.748	209.308	167	-2.7
0.8361	1.311	1.311	209.308	200.6	-1.501
0.8908	0.874	0.874	209.308	230.5	-0.4252
0.9454	0.437	0.437	209.308	258.1	0.5698
1	1.425E-13	5.407E-15	209.308	283.9	1.506

How can entropy decrease?

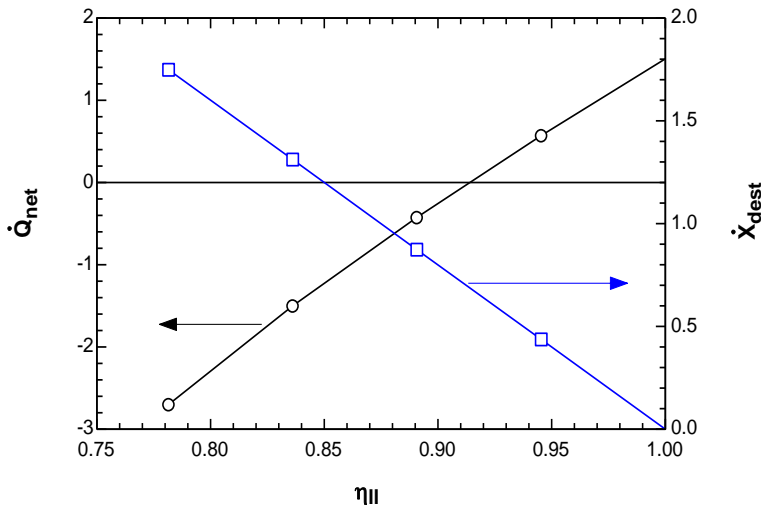
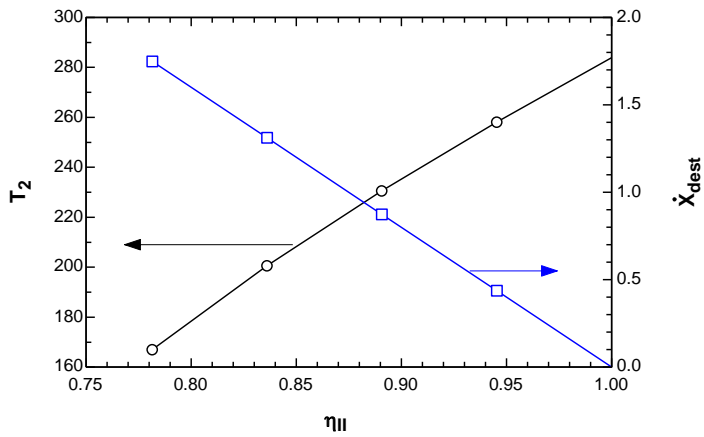
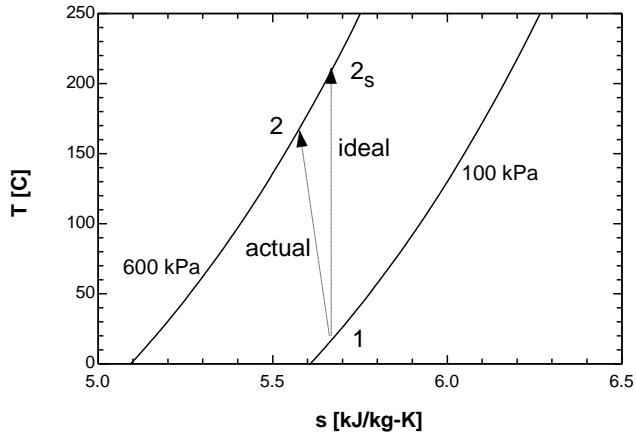

8-53 Air is accelerated in a nozzle while losing some heat to the surroundings. The exit temperature of air and the exergy destroyed during the process are to be determined.

Assumptions 1 Air is an ideal gas with variable specific heats. **2** The nozzle operates steadily.

Properties The gas constant of air is $R = 0.287 \text{ kJ/kg}\cdot\text{K}$ (Table A-1). The properties of air at the nozzle inlet are (Table A-17)

$$T_1 = 338 \text{ K} \longrightarrow h_1 = 338.40 \text{ kJ/kg}$$

$$s_1^o = 1.8219 \text{ kJ/kg}\cdot\text{K}$$

Analysis (a) We take the nozzle as the system, which is a control volume. The energy balance for this steady-flow system can be expressed in the rate form as

$$\underbrace{\dot{E}_{\text{in}} - \dot{E}_{\text{out}}}_{\substack{\text{Rate of net energy transfer} \\ \text{by heat, work, and mass}}} = \underbrace{\Delta \dot{E}_{\text{system}}}_{\substack{\text{Rate of change in internal, kinetic,} \\ \text{potential, etc. energies}}} \stackrel{\text{no (steady)}}{=} 0$$

$$\dot{E}_{\text{in}} = \dot{E}_{\text{out}}$$

$$\dot{m}(h_1 + V_1^2/2) = \dot{m}(h_2 + V_2^2/2) + \dot{Q}_{\text{out}}$$

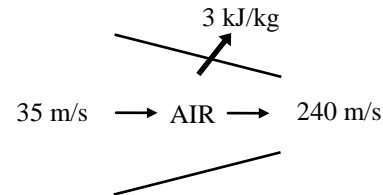

or

$$0 = q_{\text{out}} + h_2 - h_1 + \frac{V_2^2 - V_1^2}{2}$$

Therefore,

$$h_2 = h_1 - q_{\text{out}} - \frac{V_2^2 - V_1^2}{2} = 338.40 - 3 - \frac{(240 \text{ m/s})^2 - (35 \text{ m/s})^2}{2} \left(\frac{1 \text{ kJ/kg}}{1000 \text{ m}^2/\text{s}^2} \right) = 307.21 \text{ kJ/kg}$$

At this h_2 value we read, from Table A-17, $T_2 = 307.0 \text{ K} = \mathbf{34.0^\circ\text{C}}$ and $s_2^o = 1.7251 \text{ kJ/kg}\cdot\text{K}$

(b) The exergy destroyed during a process can be determined from an exergy balance or directly from its definition

$X_{\text{destroyed}} = T_0 S_{\text{gen}}$ where the entropy generation S_{gen} is determined from an entropy balance on an *extended system* that includes the device and its immediate surroundings so that the boundary temperature of the extended system is T_{surr} at all times. It gives

$$\underbrace{\dot{S}_{\text{in}} - \dot{S}_{\text{out}}}_{\substack{\text{Rate of net entropy transfer} \\ \text{by heat and mass}}} + \underbrace{\dot{S}_{\text{gen}}}_{\substack{\text{Rate of entropy} \\ \text{generation}}} = \underbrace{\Delta \dot{S}_{\text{system}}}_{\substack{\text{Rate of change} \\ \text{of entropy}}} \stackrel{\text{no}}{=} 0$$

$$ms_1 - \dot{m}s_2 - \frac{\dot{Q}_{\text{out}}}{T_{\text{b,surr}}} + \dot{S}_{\text{gen}} = 0$$

$$\dot{S}_{\text{gen}} = \dot{m}(s_2 - s_1) + \frac{\dot{Q}_{\text{out}}}{T_{\text{surr}}}$$

where

$$\Delta s_{\text{air}} = s_2^o - s_1^o - R \ln \frac{P_2}{P_1} = (1.7251 - 1.8219) \text{ kJ/kg}\cdot\text{K} - (0.287 \text{ kJ/kg}\cdot\text{K}) \ln \frac{95 \text{ kPa}}{200 \text{ kPa}} = 0.1169 \text{ kJ/kg}\cdot\text{K}$$

Substituting, the entropy generation and exergy destruction per unit mass of air are determined to be

$$x_{\text{destroyed}} = T_0 s_{\text{gen}} = T_{\text{surr}} s_{\text{gen}}$$

$$= T_0 \left(s_2 - s_1 + \frac{q_{\text{surr}}}{T_{\text{surr}}} \right) = (290 \text{ K}) \left(0.1169 \text{ kJ/kg}\cdot\text{K} + \frac{3 \text{ kJ/kg}}{290 \text{ K}} \right)$$

$$= \mathbf{36.9 \text{ kJ/kg}}$$

Alternative solution The exergy destroyed during a process can be determined from an exergy balance applied on the *extended system* that includes the device and its immediate surroundings so that the boundary temperature of the extended system is environment temperature T_0 (or T_{sur}) at all times. Noting that exergy transfer with heat is zero when the temperature at the point of transfer is the environment temperature, the exergy balance for this steady-flow system can be expressed as

$$\begin{aligned}
 \underbrace{\dot{X}_{\text{in}} - \dot{X}_{\text{out}}}_{\text{Rate of net exergy transfer by heat, work, and mass}} - \underbrace{\dot{X}_{\text{destroyed}}}_{\text{Rate of exergy destruction}} &= \underbrace{\Delta \dot{X}_{\text{system}}^{\phi_0}(\text{steady})}_{\text{Rate of change of exergy}} = 0 \rightarrow \dot{X}_{\text{destroyed}} = \dot{X}_{\text{in}} - \dot{X}_{\text{out}} = \dot{m}\psi_1 - \dot{m}\psi_2 = \dot{m}(\psi_1 - \psi_2) \\
 &= \dot{m}[(h_1 - h_2) - T_0(s_1 - s_2) - \Delta ke - \Delta pe^{\phi_0}] = \dot{m}[T_0(s_2 - s_1) - (h_2 - h_1 + \Delta ke)] \\
 &= \dot{m}[T_0(s_2 - s_1) + q_{\text{out}}] \quad \text{since, from energy balance, } -q_{\text{out}} = h_2 - h_1 + \Delta ke \\
 &= T_0 \left(\dot{m}(s_2 - s_1) + \frac{\dot{Q}_{\text{out}}}{T_0} \right) = T_0 \dot{S}_{\text{gen}}
 \end{aligned}$$

Therefore, the two approaches for the determination of exergy destruction are identical.



8-54 Problem 8-53 is reconsidered. The effect of varying the nozzle exit velocity on the exit temperature and exergy destroyed is to be investigated.

Analysis The problem is solved using EES, and the solution is given below.

"Knowns:"

```

WorkFluid$ = 'Air'
P[1] = 200 [kPa]
T[1] = 65 [C]
P[2] = 95 [kPa]
Vel[1] = 35 [m/s]
{Vel[2] = 240 [m/s]}
T_o = 17 [C]
T_surr = T_o
q_loss = 3 [kJ/kg]
  
```

"Conservation of Energy - SSSF energy balance for nozzle -- neglecting the change in potential energy:"

```

h[1]=enthalpy(WorkFluid$,T=T[1])
s[1]=entropy(WorkFluid$,P=P[1],T=T[1])
ke[1] = Vel[1]^2/2
ke[2]=Vel[2]^2/2
h[1]+ke[1]*convert(m^2/s^2,kJ/kg) = h[2] + ke[2]*convert(m^2/s^2,kJ/kg)+q_loss
T[2]=temperature(WorkFluid$,h=h[2])
s[2]=entropy(WorkFluid$,P=P[2],h=h[2])
  
```

"The entropy generated is determined from the entropy balance:"

```

s[1] - s[2] - q_loss/(T_surr+273) + s_gen = 0
x_destroyed = (T_o+273)*s_gen
  
```

Vel ₂ [m/s]	T ₂ [C]	x _{destroyed} [kJ/kg]
100	57.66	58.56
140	52.89	54.32
180	46.53	48.56
220	38.58	41.2
260	29.02	32.12
300	17.87	21.16

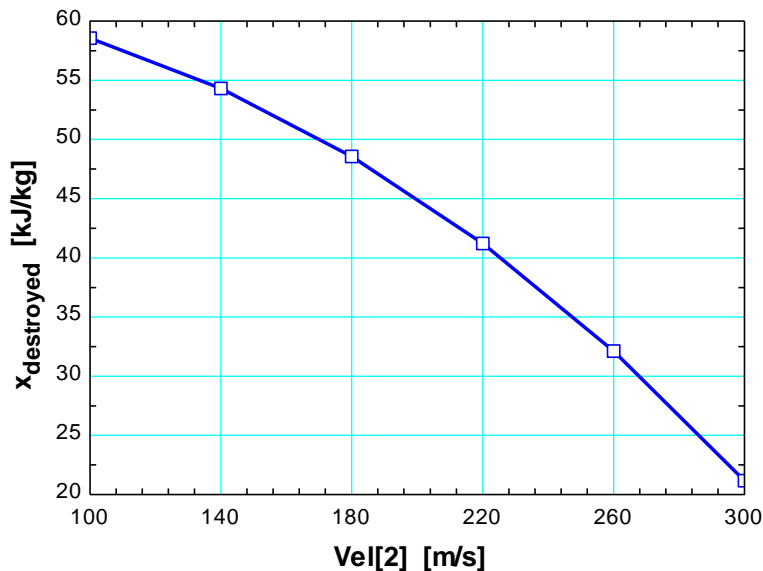
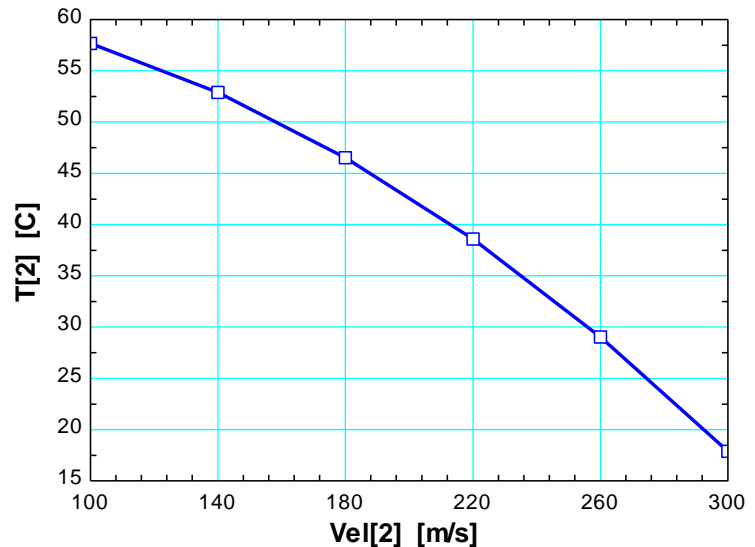

8-55 Steam is decelerated in a diffuser. The mass flow rate of steam and the wasted work potential during the process are to be determined.

Assumptions 1 The diffuser operates steadily. **2** The changes in potential energies are negligible.

Properties The properties of steam at the inlet and the exit of the diffuser are (Tables A-4 through A-6)

$$\left. \begin{array}{l} P_1 = 10 \text{ kPa} \\ T_1 = 60^\circ\text{C} \end{array} \right\} \begin{array}{l} h_1 = 2611.2 \text{ kJ/kg} \\ s_1 = 8.2326 \text{ kJ/kg} \cdot \text{K} \end{array}$$

$$\left. \begin{array}{l} T_2 = 50^\circ\text{C} \\ \text{sat. vapor} \end{array} \right\} \begin{array}{l} h_2 = 2591.3 \text{ kJ/kg} \\ s_2 = 8.0748 \text{ kJ/kg} \cdot \text{K} \\ \nu_2 = 12.026 \text{ m}^3/\text{kg} \end{array}$$

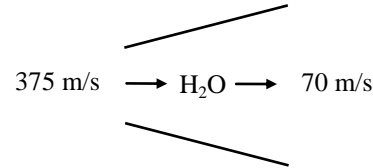

Analysis (a) The mass flow rate of the steam is

$$\dot{m} = \frac{1}{\nu_2} A_2 V_2 = \frac{1}{12.026 \text{ m}^3/\text{kg}} (3 \text{ m}^2)(70 \text{ m/s}) = \mathbf{17.46 \text{ kg/s}}$$

(b) We take the diffuser to be the system, which is a control volume. Assuming the direction of heat transfer to be from the stem, the energy balance for this steady-flow system can be expressed in the rate form as

$$\underbrace{\dot{E}_{\text{in}} - \dot{E}_{\text{out}}}_{\substack{\text{Rate of net energy transfer} \\ \text{by heat, work, and mass}}} = \underbrace{\Delta \dot{E}_{\text{system}}^{\neq 0} \text{ (steady)}}_{\substack{\text{Rate of change in internal, kinetic,} \\ \text{potential, etc. energies}}} = 0$$

$$\dot{E}_{\text{in}} = \dot{E}_{\text{out}}$$

$$\dot{m}(h_1 + V_1^2/2) = \dot{m}(h_2 + V_2^2/2) + \dot{Q}_{\text{out}}$$

$$\dot{Q}_{\text{out}} = -\dot{m} \left(h_2 - h_1 + \frac{V_2^2 - V_1^2}{2} \right)$$

Substituting,

$$\dot{Q}_{\text{out}} = -(17.46 \text{ kg/s}) \left[2591.3 - 2611.2 + \frac{(70 \text{ m/s})^2 - (375 \text{ m/s})^2}{2} \left(\frac{1 \text{ kJ/kg}}{1000 \text{ m}^2/\text{s}^2} \right) \right] = 1532 \text{ kJ/s}$$

The wasted work potential is equivalent to exergy destruction. The exergy destroyed during a process can be determined from an exergy balance or directly from its definition $X_{\text{destroyed}} = T_0 S_{\text{gen}}$ where the entropy generation S_{gen} is determined from an entropy balance on an *extended system* that includes the device and its immediate surroundings so that the boundary temperature of the extended system is T_{surr} at all times. It gives

$$\underbrace{\dot{S}_{\text{in}} - \dot{S}_{\text{out}}}_{\substack{\text{Rate of net entropy transfer} \\ \text{by heat and mass}}} + \underbrace{\dot{S}_{\text{gen}}}_{\substack{\text{Rate of entropy} \\ \text{generation}}} = \underbrace{\Delta \dot{S}_{\text{system}}^{\neq 0}}_{\substack{\text{Rate of change} \\ \text{of entropy}}} = 0$$

$$\dot{m}s_1 - \dot{m}s_2 - \frac{\dot{Q}_{\text{out}}}{T_{\text{b,surr}}} + \dot{S}_{\text{gen}} = 0 \rightarrow \dot{S}_{\text{gen}} = \dot{m}(s_2 - s_1) + \frac{\dot{Q}_{\text{out}}}{T_{\text{surr}}}$$

Substituting, the exergy destruction is determined to be

$$\begin{aligned} \dot{X}_{\text{destroyed}} &= T_0 \dot{S}_{\text{gen}} = T_0 \left(\dot{m}(s_2 - s_1) + \frac{\dot{Q}_{\text{out}}}{T_0} \right) \\ &= (298 \text{ K}) \left((17.46 \text{ kg/s})(8.0748 - 8.2326) \text{ kJ/kg} \cdot \text{K} + \frac{1532 \text{ kW}}{298 \text{ K}} \right) \\ &= \mathbf{711.1 \text{ kW}} \end{aligned}$$

8-56E Air is compressed steadily by a compressor from a specified state to another specified state. The minimum power input required for the compressor is to be determined.

Assumptions 1 Air is an ideal gas with variable specific heats. 2 Kinetic and potential energy changes are negligible.

Properties The gas constant of air is $R = 0.06855 \text{ Btu/lbm}\cdot\text{R}$ (Table A-1E). From the air table (Table A-17E)

$$\begin{aligned} T_1 = 520 \text{ R} &\longrightarrow h_1 = 124.27 \text{ Btu/lbm} \\ & s_1^\circ = 0.59173 \text{ Btu/lbm}\cdot\text{R} \\ T_2 = 940 \text{ R} &\longrightarrow h_2 = 226.11 \text{ Btu/lbm} \\ & s_2^\circ = 0.73509 \text{ Btu/lbm}\cdot\text{R} \end{aligned}$$

Analysis The reversible (or minimum) power input is determined from the rate form of the exergy balance applied on the compressor and setting the exergy destruction term equal to zero,

$$\underbrace{\dot{X}_{\text{in}} - \dot{X}_{\text{out}}}_{\text{Rate of net exergy transfer by heat, work, and mass}} - \underbrace{\dot{X}_{\text{destroyed}}}_{\text{Rate of exergy destruction}} \stackrel{\text{reversible}}{=} \underbrace{\Delta\dot{X}_{\text{system}}}_{\text{Rate of change of exergy}} \stackrel{\text{steady}}{=} 0$$

$$\begin{aligned} \dot{X}_{\text{in}} &= \dot{X}_{\text{out}} \\ \dot{m}\psi_1 + \dot{W}_{\text{rev,in}} &= \dot{m}\psi_2 \end{aligned}$$

$$\dot{W}_{\text{rev,in}} = \dot{m}(\psi_2 - \psi_1) = \dot{m}[(h_2 - h_1) - T_0(s_2 - s_1) + \Delta ke^{\text{re}} + \Delta pe^{\text{re}}]$$

where

$$\begin{aligned} \Delta s_{\text{air}} &= s_2^\circ - s_1^\circ - R \ln \frac{P_2}{P_1} \\ &= (0.73509 - 0.59173) \text{ Btu/lbm}\cdot\text{R} - (0.06855 \text{ Btu/lbm}\cdot\text{R}) \ln \frac{100 \text{ psia}}{14.7 \text{ psia}} \\ &= 0.01193 \text{ Btu/lbm}\cdot\text{R} \end{aligned}$$

Substituting,

$$\begin{aligned} \dot{W}_{\text{rev,in}} &= (22/60 \text{ lbm/s})[(226.11 - 124.27) \text{ Btu/lbm} - (520 \text{ R})(0.01193 \text{ Btu/lbm}\cdot\text{R})] \\ &= 35.1 \text{ Btu/s} = \mathbf{49.6 \text{ hp}} \end{aligned}$$

Discussion Note that this is the minimum power input needed for this compressor.

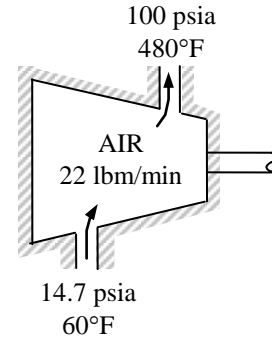

8-57 Argon enters an adiabatic compressor at a specified state, and leaves at another specified state. The reversible power input and irreversibility are to be determined.

Assumptions 1 This is a steady-flow process since there is no change with time. **2** Potential energy changes are negligible. **3** The device is adiabatic and thus heat transfer is negligible. **4** Argon is an ideal gas with constant specific heats.

Properties For argon, the gas constant is $R = 0.2081 \text{ kJ/kg}\cdot\text{K}$; the specific heat ratio is $k = 1.667$; the constant pressure specific heat is $c_p = 0.5203 \text{ kJ/kg}\cdot\text{K}$ (Table A-2).

Analysis The mass flow rate, the entropy change, and the kinetic energy change of argon during this process are

$$v_1 = \frac{RT_1}{P_1} = \frac{(0.2081 \text{ kPa}\cdot\text{m}^3/\text{kg}\cdot\text{K})(303 \text{ K})}{(120 \text{ kPa})} = 0.5255 \text{ m}^3/\text{kg}$$

$$\dot{m} = \frac{1}{v_1} A_1 V_1 = \frac{1}{0.5255 \text{ m}^3/\text{kg}} (0.0130 \text{ m}^2)(20 \text{ m/s}) = 0.495 \text{ kg/s}$$

$$\begin{aligned} s_2 - s_1 &= c_p \ln \frac{T_2}{T_1} - R \ln \frac{P_2}{P_1} \\ &= (0.5203 \text{ kJ/kg}\cdot\text{K}) \ln \frac{803 \text{ K}}{303 \text{ K}} - (0.2081 \text{ kJ/kg}\cdot\text{K}) \ln \frac{1200 \text{ kPa}}{120 \text{ kPa}} \\ &= 0.02793 \text{ kJ/kg}\cdot\text{K} \end{aligned}$$

and

$$\Delta ke = \frac{V_2^2 - V_1^2}{2} = \frac{(80 \text{ m/s})^2 - (20 \text{ m/s})^2}{2} \left(\frac{1 \text{ kJ/kg}}{1000 \text{ m}^2/\text{s}^2} \right) = 3.0 \text{ kJ/kg}$$

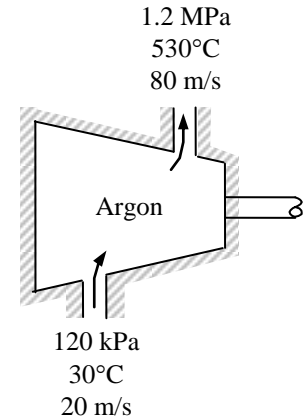

The reversible (or minimum) power input is determined from the rate form of the exergy balance applied on the compressor, and setting the exergy destruction term equal to zero,

$$\underbrace{\dot{X}_{\text{in}} - \dot{X}_{\text{out}}}_{\text{Rate of net exergy transfer by heat, work, and mass}} - \underbrace{\dot{X}_{\text{destroyed}}}_{\text{Rate of exergy destruction}} \stackrel{\approx 0 \text{ (reversible)}}{=} \underbrace{\Delta \dot{X}_{\text{system}}}_{\text{Rate of change of exergy}} \stackrel{\approx 0 \text{ (steady)}}{=} 0$$

$$\dot{X}_{\text{in}} = \dot{X}_{\text{out}}$$

$$\dot{m}\psi_1 + \dot{W}_{\text{rev, in}} = \dot{m}\psi_2$$

$$\dot{W}_{\text{rev, in}} = \dot{m}(\psi_2 - \psi_1) = \dot{m}[(h_2 - h_1) - T_0(s_2 - s_1) + \Delta ke + \Delta pe^{\approx 0}]$$

Substituting,

$$\begin{aligned} \dot{W}_{\text{rev, in}} &= \dot{m}[c_p(T_2 - T_1) - T_0(s_2 - s_1) + \Delta ke] \\ &= (0.495 \text{ kg/s})[(0.5203 \text{ kJ/kg}\cdot\text{K})(530 - 30)\text{K} - (298 \text{ K})(0.02793 \text{ kJ/kg}\cdot\text{K}) + 3.0] = \mathbf{126 \text{ kW}} \end{aligned}$$

The exergy destruction (or irreversibility) can be determined from an exergy balance or directly from its definition $X_{\text{destroyed}} = T_0 S_{\text{gen}}$ where the entropy generation is determined from an entropy balance on the system, which is an adiabatic steady-flow device,

$$\underbrace{\dot{S}_{\text{in}} - \dot{S}_{\text{out}}}_{\text{Rate of net entropy transfer by heat and mass}} + \underbrace{\dot{S}_{\text{gen}}}_{\text{Rate of entropy generation}} = \underbrace{\Delta \dot{S}_{\text{system}}}_{\text{Rate of change of entropy}} \stackrel{\approx 0}{=} 0$$

$$\dot{m}s_1 - \dot{m}s_2 + \dot{S}_{\text{gen}} = 0 \rightarrow \dot{S}_{\text{gen}} = \dot{m}(s_2 - s_1)$$

Substituting,

$$\dot{X}_{\text{destroyed}} = T_0 \dot{m}(s_2 - s_1) = (298 \text{ K})(0.495 \text{ kg/s})(0.02793 \text{ kJ/kg}\cdot\text{K}) = \mathbf{4.12 \text{ kW}}$$

8-58 Steam expands in a turbine from a specified state to another specified state. The actual power output of the turbine is given. The reversible power output and the second-law efficiency are to be determined.

Assumptions 1 This is a steady-flow process since there is no change with time. **2** Potential energy change is negligible. **3** The temperature of the surroundings is given to be 25°C.

Properties From the steam tables (Tables A-4 through A-6)

$$\left. \begin{array}{l} P_1 = 6 \text{ MPa} \\ T_1 = 600^\circ\text{C} \end{array} \right\} \begin{array}{l} h_1 = 3658.8 \text{ kJ/kg} \\ s_1 = 7.1693 \text{ kJ/kg}\cdot\text{K} \end{array}$$

$$\left. \begin{array}{l} P_2 = 50 \text{ kPa} \\ T_2 = 100^\circ\text{C} \end{array} \right\} \begin{array}{l} h_2 = 2682.4 \text{ kJ/kg} \\ s_2 = 7.6953 \text{ kJ/kg}\cdot\text{K} \end{array}$$

Analysis (b) There is only one inlet and one exit, and thus $\dot{m}_1 = \dot{m}_2 = \dot{m}$. We take the turbine as the system, which is a control volume since mass crosses the boundary. The energy balance for this steady-flow system can be expressed in the rate form as

$$\underbrace{\dot{E}_{\text{in}} - \dot{E}_{\text{out}}}_{\text{Rate of net energy transfer by heat, work, and mass}} = \underbrace{\Delta\dot{E}_{\text{system}}^{\text{no (steady)}}}_{\text{Rate of change in internal, kinetic, potential, etc. energies}} = 0$$

$$\dot{E}_{\text{in}} = \dot{E}_{\text{out}}$$

$$\dot{m}(h_1 + V_1^2/2) = \dot{W}_{\text{out}} + \dot{m}(h_2 + V_2^2/2)$$

$$\dot{W}_{\text{out}} = \dot{m} \left[h_1 - h_2 + \frac{V_1^2 - V_2^2}{2} \right]$$

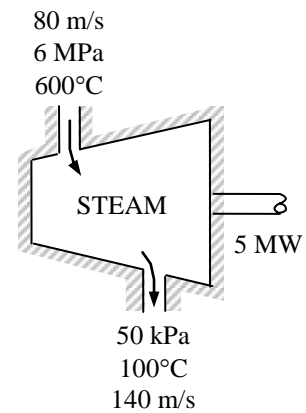

Substituting,

$$5000 \text{ kJ/s} = \dot{m} \left(3658.8 - 2682.4 + \frac{(80 \text{ m/s})^2 - (140 \text{ m/s})^2}{2} \left(\frac{1 \text{ kJ/kg}}{1000 \text{ m}^2/\text{s}^2} \right) \right)$$

$$\dot{m} = 5.156 \text{ kg/s}$$

The reversible (or maximum) power output is determined from the rate form of the exergy balance applied on the turbine and setting the exergy destruction term equal to zero,

$$\underbrace{\dot{X}_{\text{in}} - \dot{X}_{\text{out}}}_{\text{Rate of net exergy transfer by heat, work, and mass}} - \underbrace{\dot{X}_{\text{destroyed}}^{\text{no (reversible)}}}_{\text{Rate of exergy destruction}} = \underbrace{\Delta\dot{X}_{\text{system}}^{\text{no (steady)}}}_{\text{Rate of change of exergy}} = 0$$

$$\dot{X}_{\text{in}} = \dot{X}_{\text{out}}$$

$$\dot{m}\psi_1 = \dot{W}_{\text{rev,out}} + \dot{m}\psi_2$$

$$\dot{W}_{\text{rev,out}} = \dot{m}(\psi_1 - \psi_2) = \dot{m}[(h_1 - h_2) - T_0(s_1 - s_2) - \Delta\text{ke} - \Delta\text{pe}^{\text{no}}]$$

Substituting,

$$\begin{aligned} \dot{W}_{\text{rev,out}} &= \dot{W}_{\text{out}} - \dot{m}T_0(s_1 - s_2) \\ &= 5000 \text{ kW} - (5.156 \text{ kg/s})(298 \text{ K})(7.1693 - 7.6953) \text{ kJ/kg}\cdot\text{K} = \mathbf{5808 \text{ kW}} \end{aligned}$$

(b) The second-law efficiency of a turbine is the ratio of the actual work output to the reversible work,

$$\eta_{\text{II}} = \frac{\dot{W}_{\text{out}}}{\dot{W}_{\text{rev,out}}} = \frac{5 \text{ MW}}{5.808 \text{ MW}} = \mathbf{86.1\%}$$

Discussion Note that 13.9% percent of the work potential of the steam is wasted as it flows through the turbine during this process.

8-59 Steam is throttled from a specified state to a specified pressure. The decrease in the exergy of the steam during this throttling process is to be determined.

Assumptions 1 This is a steady-flow process since there is no change with time. **2** Kinetic and potential energy changes are negligible. **3** The temperature of the surroundings is given to be 25°C. **4** Heat transfer is negligible.

Properties The properties of steam before and after throttling are (Tables A-4 through A-6)

$$\left. \begin{array}{l} P_1 = 7 \text{ MPa} \\ T_1 = 500^\circ\text{C} \end{array} \right\} \begin{array}{l} h_1 = 3411.4 \text{ kJ/kg} \\ s_1 = 6.8000 \text{ kJ/kg} \cdot \text{K} \end{array}$$

$$\left. \begin{array}{l} P_2 = 1 \text{ MPa} \\ h_2 = h_1 \end{array} \right\} s_2 = 7.6748 \text{ kJ/kg} \cdot \text{K}$$

Analysis The decrease in exergy of the steam is the difference between the inlet and exit flow exergies,

$$\begin{aligned} \text{Decrease in exergy} &= \psi_1 - \psi_2 = -[\Delta h^{\text{ex}} - \Delta ke^{\text{ex}} - \Delta pe^{\text{ex}} - T_0(s_1 - s_2)] = T_0(s_2 - s_1) \\ &= (298 \text{ K})(7.6748 - 6.8000) \text{ kJ/kg} \cdot \text{K} \\ &= \mathbf{261 \text{ kJ/kg}} \end{aligned}$$

Discussion Note that 261 kJ/kg of work potential is wasted during this throttling process.

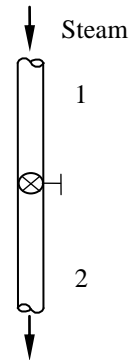

8-60 CO₂ gas is compressed steadily by a compressor from a specified state to another specified state. The power input to the compressor if the process involved no irreversibilities is to be determined.

Assumptions 1 This is a steady-flow process since there is no change with time. **2** Kinetic and potential energy changes are negligible. **3** CO₂ is an ideal gas with constant specific heats.

Properties At the average temperature of $(300 + 450)/2 = 375$ K, the constant pressure specific heat and the specific heat ratio of CO₂ are $c_p = 0.917$ kJ/kg·K and $k = 1.261$ (Table A-2b). Also, $c_p = 0.1889$ kJ/kg·K (Table A-2a).

Analysis The reversible (or minimum) power input is determined from the exergy balance applied on the compressor, and setting the exergy destruction term equal to zero,

$$\underbrace{\dot{X}_{\text{in}} - \dot{X}_{\text{out}}}_{\text{Rate of net exergy transfer by heat, work, and mass}} - \underbrace{\dot{X}_{\text{destroyed}}}_{\text{Rate of exergy destruction}} \stackrel{\text{reversible}}{=} \underbrace{\Delta \dot{X}_{\text{system}}}_{\text{Rate of change of exergy}} \stackrel{\text{steady}}{=} 0$$

$$\dot{X}_{\text{in}} = \dot{X}_{\text{out}}$$

$$\dot{m}\psi_1 + \dot{W}_{\text{rev,in}} = \dot{m}\psi_2$$

$$\dot{W}_{\text{rev,in}} = \dot{m}(\psi_2 - \psi_1)$$

$$= \dot{m}[(h_2 - h_1) - T_0(s_2 - s_1) + \Delta ke^{\text{rev}} + \Delta pe^{\text{rev}}]$$

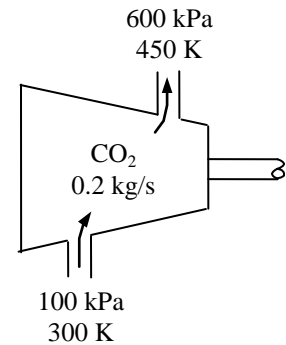

where

$$s_2 - s_1 = c_p \ln \frac{T_2}{T_1} - R \ln \frac{P_2}{P_1}$$

$$= (0.917 \text{ kJ/kg} \cdot \text{K}) \ln \frac{450 \text{ K}}{300 \text{ K}} - (0.1889 \text{ kJ/kg} \cdot \text{K}) \ln \frac{600 \text{ kPa}}{100 \text{ kPa}}$$

$$= 0.03335 \text{ kJ/kg} \cdot \text{K}$$

Substituting,

$$\dot{W}_{\text{rev,in}} = (0.2 \text{ kg/s})[(0.917 \text{ kJ/kg} \cdot \text{K})(450 - 300)\text{K} - (298 \text{ K})(0.03335 \text{ kJ/kg} \cdot \text{K})] = \mathbf{25.5 \text{ kW}}$$

Discussion Note that a minimum of 25.5 kW of power input is needed for this compressor.

8-61 Combustion gases expand in a turbine from a specified state to another specified state. The exergy of the gases at the inlet and the reversible work output of the turbine are to be determined.

Assumptions 1 This is a steady-flow process since there is no change with time. **2** Potential energy changes are negligible. **3** The temperature of the surroundings is given to be 25°C. **4** The combustion gases are ideal gases with constant specific heats.

Properties The constant pressure specific heat and the specific heat ratio are given to be $c_p = 1.15 \text{ kJ/kg}\cdot\text{K}$ and $k = 1.3$. The gas constant R is determined from

$$R = c_p - c_v = c_p - c_p / k = c_p (1 - 1/k) = (1.15 \text{ kJ/kg}\cdot\text{K})(1 - 1/1.3) = 0.265 \text{ kJ/kg}\cdot\text{K}$$

Analysis (a) The exergy of the gases at the turbine inlet is simply the flow exergy,

$$\psi_1 = h_1 - h_0 - T_0(s_1 - s_0) + \frac{V_1^2}{2} + gz_1^{\phi_0}$$

where

$$\begin{aligned} s_1 - s_0 &= c_p \ln \frac{T_1}{T_0} - R \ln \frac{P_1}{P_0} \\ &= (1.15 \text{ kJ/kg}\cdot\text{K}) \ln \frac{1173 \text{ K}}{298 \text{ K}} - (0.265 \text{ kJ/kg}\cdot\text{K}) \ln \frac{800 \text{ kPa}}{100 \text{ kPa}} \\ &= 1.025 \text{ kJ/kg}\cdot\text{K} \end{aligned}$$

Thus,

$$\psi_1 = (1.15 \text{ kJ/kg}\cdot\text{K})(900 - 25)^\circ\text{C} - (298 \text{ K})(1.025 \text{ kJ/kg}\cdot\text{K}) + \frac{(100 \text{ m/s})^2}{2} \left(\frac{1 \text{ kJ/kg}}{1000 \text{ m}^2/\text{s}^2} \right) = \mathbf{705.8 \text{ kJ/kg}}$$

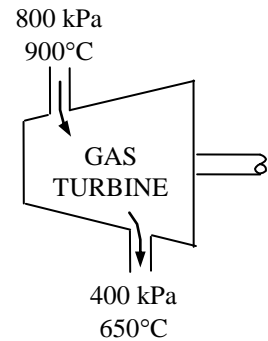

(b) The reversible (or maximum) work output is determined from an exergy balance applied on the turbine and setting the exergy destruction term equal to zero,

$$\begin{aligned} \underbrace{\dot{X}_{\text{in}} - \dot{X}_{\text{out}}}_{\text{Rate of net exergy transfer by heat, work, and mass}} - \underbrace{\dot{X}_{\text{destroyed}}^{\phi_0}}_{\text{Rate of exergy destruction (reversible)}} &= \underbrace{\Delta \dot{X}_{\text{system}}^{\phi_0}}_{\text{Rate of change of exergy (steady)}} = 0 \\ \dot{X}_{\text{in}} &= \dot{X}_{\text{out}} \\ \dot{m} \psi_1 &= \dot{W}_{\text{rev,out}} + \dot{m} \psi_2 \\ \dot{W}_{\text{rev,out}} &= \dot{m}(\psi_1 - \psi_2) = \dot{m}[(h_1 - h_2) - T_0(s_1 - s_2) - \Delta ke - \Delta pe^{\phi_0}] \end{aligned}$$

where

$$\Delta ke = \frac{V_2^2 - V_1^2}{2} = \frac{(220 \text{ m/s})^2 - (100 \text{ m/s})^2}{2} \left(\frac{1 \text{ kJ/kg}}{1000 \text{ m}^2/\text{s}^2} \right) = 19.2 \text{ kJ/kg}$$

and

$$\begin{aligned} s_2 - s_1 &= c_p \ln \frac{T_2}{T_1} - R \ln \frac{P_2}{P_1} \\ &= (1.15 \text{ kJ/kg}\cdot\text{K}) \ln \frac{923 \text{ K}}{1173 \text{ K}} - (0.265 \text{ kJ/kg}\cdot\text{K}) \ln \frac{400 \text{ kPa}}{800 \text{ kPa}} \\ &= -0.09196 \text{ kJ/kg}\cdot\text{K} \end{aligned}$$

Then the reversible work output on a unit mass basis becomes

$$\begin{aligned} w_{\text{rev,out}} &= h_1 - h_2 + T_0(s_2 - s_1) - \Delta ke = c_p(T_1 - T_2) + T_0(s_2 - s_1) - \Delta ke \\ &= (1.15 \text{ kJ/kg}\cdot\text{K})(900 - 650)^\circ\text{C} + (298 \text{ K})(-0.09196 \text{ kJ/kg}\cdot\text{K}) - 19.2 \text{ kJ/kg} \\ &= \mathbf{240.9 \text{ kJ/kg}} \end{aligned}$$

8-62 Refrigerant-134a enters an adiabatic compressor at a specified state with a specified volume flow rate, and leaves at a specified state. The power input, the isentropic efficiency, the rate of exergy destruction, and the second-law efficiency are to be determined.

Assumptions 1 This is a steady-flow process since there is no change with time. **2** Kinetic and potential energy changes are negligible. **3** The device is adiabatic and thus heat transfer is negligible.

Analysis (a) The properties of refrigerant at the inlet and exit states of the compressor are obtained from R-134a tables:

$$\begin{array}{l}
 T_1 = -30^\circ\text{C} \\
 x_1 = 1
 \end{array}
 \left.
 \begin{array}{l}
 h_1 = 232.19 \text{ kJ/kg} \\
 s_1 = 0.9559 \text{ kJ/kg} \cdot \text{K} \\
 v_1 = 0.22577 \text{ m}^3/\text{kg}
 \end{array}
 \right\}$$

$$\begin{array}{l}
 P_2 = 900 \text{ kPa} \\
 T_2 = 55^\circ\text{C}
 \end{array}
 \left.
 \begin{array}{l}
 h_2 = 289.99 \text{ kJ/kg} \\
 s_2 = 0.9821 \text{ kJ/kg} \cdot \text{K}
 \end{array}
 \right\}$$

For the isentropic exit state,

$$\begin{array}{l}
 P_2 = 900 \text{ kPa} \\
 s_{2s} = s_1 = 0.9559 \text{ kJ/kg} \cdot \text{K}
 \end{array}
 \left.
 \right\} h_{2s} = 281.49 \text{ kJ/kg}$$

The mass flow rate of the refrigerant and the actual power input are

$$\dot{m} = \frac{\dot{V}_1}{v_1} = \frac{(0.45/60) \text{ m}^3/\text{s}}{0.22577 \text{ m}^3/\text{kg}} = 0.03322 \text{ kg/s}$$

$$\dot{W}_{\text{act}} = \dot{m}(h_2 - h_1) = (0.03322 \text{ kg/s})(289.99 - 232.19) \text{ kJ/kg} = \mathbf{1.920 \text{ kW}}$$

(b) The power input for the isentropic case and the isentropic efficiency are

$$\dot{W}_{\text{isen}} = \dot{m}(h_{2s} - h_1) = (0.03322 \text{ kg/s})(281.49 - 232.19) \text{ kJ/kg} = 1.638 \text{ kW}$$

$$\eta_{\text{Comp,isen}} = \frac{\dot{W}_{\text{isen}}}{\dot{W}_{\text{act}}} = \frac{1.638 \text{ kW}}{1.920 \text{ kW}} = 0.8531 = \mathbf{85.3\%}$$

(c) The exergy destruction is

$$\dot{X}_{\text{dest}} = \dot{m}T_0(s_2 - s_1) = (0.03322 \text{ kg/s})(300 \text{ K})(0.9821 - 0.9559) \text{ kJ/kg} \cdot \text{K} = \mathbf{0.2612 \text{ kW}}$$

The reversible power and the second-law efficiency are

$$\dot{W}_{\text{rev}} = \dot{W}_{\text{act}} - \dot{X}_{\text{dest}} = 1.920 - 0.2612 = 1.659 \text{ kW}$$

$$\eta_{\text{Comp,II}} = \frac{\dot{W}_{\text{rev}}}{\dot{W}_{\text{act}}} = \frac{1.659 \text{ kW}}{1.920 \text{ kW}} = 0.8640 = \mathbf{86.4\%}$$

8-63 Refrigerant-134a is condensed in a refrigeration system by rejecting heat to ambient air. The rate of heat rejected, the COP of the refrigeration cycle, and the rate of exergy destruction are to be determined.

Assumptions 1 This is a steady-flow process since there is no change with time. **2** Kinetic and potential energy changes are negligible.

Analysis (a) The properties of refrigerant at the inlet and exit states of the condenser are (from R134a tables)

$$\left. \begin{array}{l} P_1 = 700 \text{ kPa} \\ T_1 = 50^\circ\text{C} \end{array} \right\} \begin{array}{l} h_1 = 288.54 \text{ kJ/kg} \\ s_1 = 0.9955 \text{ kJ/kg} \cdot \text{K} \end{array}$$

$$\left. \begin{array}{l} P_2 = 700 \text{ kPa} \\ x_2 = 0 \end{array} \right\} \begin{array}{l} h_2 = 88.82 \text{ kJ/kg} \\ s_2 = 0.3323 \text{ kJ/kg} \cdot \text{K} \end{array}$$

The rate of heat rejected in the condenser is

$$\dot{Q}_H = \dot{m}_R (h_1 - h_2) = (0.05 \text{ kg/s})(288.54 - 88.82) \text{ kJ/kg} = \mathbf{9.986 \text{ kW}}$$

(b) From the definition of COP for a refrigerator,

$$\text{COP} = \frac{\dot{Q}_L}{\dot{W}_{\text{in}}} = \frac{\dot{Q}_L}{\dot{Q}_H - \dot{Q}_L} = \frac{6 \text{ kW}}{(9.986 - 6) \text{ kW}} = \mathbf{1.505}$$

(c) The entropy generation and the exergy destruction in the condenser are

$$\begin{aligned} \dot{S}_{\text{gen}} &= \dot{m}_R (s_2 - s_1) + \frac{\dot{Q}_H}{T_H} \\ &= (0.05 \text{ kg/s})(0.3323 - 0.9955) \text{ kJ/kg} \cdot \text{K} + \frac{9.986 \text{ kW}}{298 \text{ K}} \\ &= 0.0003517 \text{ kW/K} \end{aligned}$$

$$\dot{X}_{\text{dest}} = T_0 \dot{S}_{\text{gen}} = (298 \text{ K})(0.0003517 \text{ kJ/kg} \cdot \text{K}) = \mathbf{0.1048 \text{ kW}}$$

8-64 Refrigerant-134a is vaporized by air in the evaporator of an air-conditioner. For specified flow rates, the exit temperature of air and the rate of exergy destruction are to be determined for the cases of insulated and uninsulated evaporator.

Assumptions 1 This is a steady-flow process since there is no change with time. **2** Kinetic and potential energy changes are negligible. **3** There are no work interactions. **4** Air is an ideal gas with constant specific heats at room temperature.

Properties The gas constant of air is $0.287 \text{ kPa}\cdot\text{m}^3/\text{kg}\cdot\text{K}$ (Table A-1). The constant pressure specific heat of air at room temperature is $c_p = 1.005 \text{ kJ/kg}\cdot\text{K}$ (Table A-2). The properties of R-134a at the inlet and the exit states are (Tables A-11 through A-13)

$$P_1 = 120 \text{ kPa} \left\{ \begin{array}{l} h_1 = h_f + x_1 h_{fg} = 22.47 + 0.3 \times 214.52 = 86.83 \text{ kJ/kg} \\ x_1 = 0.3 \end{array} \right. \left\{ \begin{array}{l} s_1 = s_f + x_1 s_{fg} = 0.09269 + 0.3(0.85520) = 0.34925 \text{ kJ/kg}\cdot\text{K} \end{array} \right.$$

$$T_2 = 120 \text{ kPa} \left\{ \begin{array}{l} h_2 = h_{g@120\text{kPa}} = 236.99 \text{ kJ/kg} \\ \text{sat. vapor} \end{array} \right. \left\{ \begin{array}{l} s_2 = s_{g@120\text{kPa}} = 0.94789 \text{ kJ/kg}\cdot\text{K} \end{array} \right.$$

Analysis Air at specified conditions can be treated as an ideal gas with specific heats at room temperature. The properties of the refrigerant are

$$\dot{m}_{\text{air}} = \frac{P_3 \dot{V}_3}{RT_3} = \frac{(100 \text{ kPa})(6 \text{ m}^3/\text{min})}{(0.287 \text{ kPa}\cdot\text{m}^3/\text{kg}\cdot\text{K})(300 \text{ K})} = 6.969 \text{ kg/min}$$

(a) We take the entire heat exchanger as the system, which is a control volume. The mass and energy balances for this steady-flow system can be expressed in the rate form as:

Mass balance (for each fluid stream):

$$\dot{m}_{\text{in}} - \dot{m}_{\text{out}} = \Delta \dot{m}_{\text{system}} \stackrel{\approx 0 \text{ (steady)}}{=} 0 \rightarrow \dot{m}_{\text{in}} = \dot{m}_{\text{out}} \rightarrow \dot{m}_1 = \dot{m}_2 = \dot{m}_{\text{air}} \text{ and } \dot{m}_3 = \dot{m}_4 = \dot{m}_R$$

Energy balance (for the entire heat exchanger):

$$\underbrace{\dot{E}_{\text{in}} - \dot{E}_{\text{out}}}_{\text{Rate of net energy transfer by heat, work, and mass}} = \underbrace{\Delta \dot{E}_{\text{system}}}_{\text{Rate of change in internal, kinetic, potential, etc. energies}} \stackrel{\approx 0 \text{ (steady)}}{=} 0$$

$$\dot{E}_{\text{in}} = \dot{E}_{\text{out}}$$

$$\dot{m}_1 h_1 + \dot{m}_3 h_3 = \dot{m}_2 h_2 + \dot{m}_4 h_4 \quad (\text{since } \dot{Q} = \dot{W} = \Delta \text{ke} \cong \Delta \text{pe} \cong 0)$$

Combining the two,

$$\dot{m}_R (h_2 - h_1) = \dot{m}_{\text{air}} (h_3 - h_4) = \dot{m}_{\text{air}} c_p (T_3 - T_4)$$

$$\text{Solving for } T_4, \quad T_4 = T_3 - \frac{\dot{m}_R (h_2 - h_1)}{\dot{m}_{\text{air}} c_p}$$

$$\text{Substituting,} \quad T_4 = 27^\circ\text{C} - \frac{(2 \text{ kg/min})(236.99 - 86.83) \text{ kJ/kg}}{(6.969 \text{ kg/min})(1.005 \text{ kJ/kg}\cdot\text{K})} = -15.9^\circ\text{C} = 257.1 \text{ K}$$

The exergy destroyed during a process can be determined from an exergy balance or directly from its definition $X_{\text{destroyed}} = T_0 S_{\text{gen}}$ where the entropy generation S_{gen} is determined from an entropy balance on the evaporator.

Noting that the condenser is well-insulated and thus heat transfer is negligible, the entropy balance for this steady-flow system can be expressed as

$$\underbrace{\dot{S}_{\text{in}} - \dot{S}_{\text{out}}}_{\text{Rate of net entropy transfer by heat and mass}} + \underbrace{\dot{S}_{\text{gen}}}_{\text{Rate of entropy generation}} = \underbrace{\Delta \dot{S}_{\text{system}}}_{\text{Rate of change of entropy}} \stackrel{\approx 0 \text{ (steady)}}{=} 0$$

$$\dot{m}_1 s_1 + \dot{m}_3 s_3 - \dot{m}_2 s_2 - \dot{m}_4 s_4 + \dot{S}_{\text{gen}} = 0 \quad (\text{since } \dot{Q} = 0)$$

$$\dot{m}_R s_1 + \dot{m}_{\text{air}} s_3 - \dot{m}_R s_2 - \dot{m}_{\text{air}} s_4 + \dot{S}_{\text{gen}} = 0$$

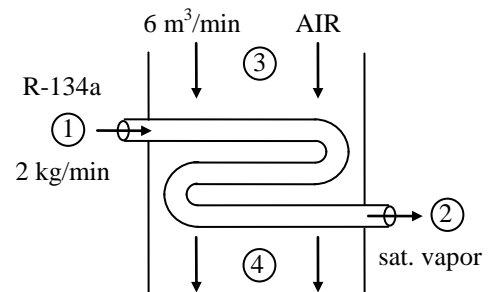

$$\text{or } \dot{S}_{\text{gen}} = \dot{m}_R(s_2 - s_1) + \dot{m}_{\text{air}}(s_4 - s_3)$$

where

$$s_4 - s_3 = c_p \ln \frac{T_4}{T_3} - R \ln \frac{P_4^{\phi_0}}{P_3} = c_p \ln \frac{T_4}{T_3} = (1.005 \text{ kJ/kg} \cdot \text{K}) \ln \frac{257.1 \text{ K}}{300 \text{ K}} = -0.1550 \text{ kJ/kg} \cdot \text{K}$$

Substituting, the exergy destruction is determined to be

$$\begin{aligned} \dot{X}_{\text{destroyed}} &= T_0 \dot{S}_{\text{gen}} = T_0 [\dot{m}_R(s_2 - s_1) + \dot{m}_{\text{air}}(s_4 - s_3)] \\ &= (305 \text{ K}) [(2 \text{ kg/min})(0.94789 - 0.34925) \text{ kJ/kg} \cdot \text{K} + (6.969 \text{ kg/min})(-0.1551 \text{ kJ/kg} \cdot \text{K})] \\ &= 35.50 \text{ kJ/min} = \mathbf{0.592 \text{ kW}} \end{aligned}$$

(b) When there is a heat gain from the surroundings, the steady-flow energy equation reduces to

$$\dot{Q}_{\text{in}} = \dot{m}_R(h_2 - h_1) + \dot{m}_{\text{air}} c_p (T_4 - T_3)$$

$$\text{Solving for } T_4, \quad T_4 = T_3 + \frac{\dot{Q}_{\text{in}} - \dot{m}_R(h_2 - h_1)}{\dot{m}_{\text{air}} c_p}$$

Substituting,

$$T_4 = 27^\circ\text{C} + \frac{(30 \text{ kJ/min}) - (2 \text{ kg/min})(236.99 - 86.83) \text{ kJ/kg}}{(6.969 \text{ kg/min})(1.005 \text{ kJ/kg} \cdot \text{K})} = \mathbf{-11.6^\circ\text{C}} = 261.4 \text{ K}$$

The exergy destroyed during a process can be determined from an exergy balance or directly from its definition $\dot{X}_{\text{destroyed}} = T_0 \dot{S}_{\text{gen}}$ where the entropy generation \dot{S}_{gen} is determined from an entropy balance on an *extended system* that includes the evaporator and its immediate surroundings. It gives

$$\underbrace{\dot{S}_{\text{in}} - \dot{S}_{\text{out}}}_{\text{Rate of net entropy transfer by heat and mass}} + \underbrace{\dot{S}_{\text{gen}}}_{\text{Rate of entropy generation}} = \underbrace{\Delta \dot{S}_{\text{system}}^{\phi_0(\text{steady})}}_{\text{Rate of change of entropy}}$$

$$\frac{\dot{Q}_{\text{in}}}{T_{\text{b,in}}} + \dot{m}_1 s_1 + \dot{m}_3 s_3 - \dot{m}_2 s_2 - \dot{m}_4 s_4 + \dot{S}_{\text{gen}} = 0$$

$$\frac{\dot{Q}_{\text{in}}}{T_0} + \dot{m}_R s_1 + \dot{m}_{\text{air}} s_3 - \dot{m}_R s_2 - \dot{m}_{\text{air}} s_4 + \dot{S}_{\text{gen}} = 0$$

$$\text{or } \dot{S}_{\text{gen}} = \dot{m}_R(s_2 - s_1) + \dot{m}_{\text{air}}(s_4 - s_3) - \frac{\dot{Q}_{\text{in}}}{T_0}$$

where

$$s_4 - s_3 = c_p \ln \frac{T_4}{T_3} - R \ln \frac{P_4^{\phi_0}}{P_3} = (1.005 \text{ kJ/kg} \cdot \text{K}) \ln \frac{261.4 \text{ K}}{300 \text{ K}} = -0.1384 \text{ kJ/kg} \cdot \text{K}$$

Substituting, the exergy destruction is determined to be

$$\begin{aligned} \dot{X}_{\text{destroyed}} &= T_0 \dot{S}_{\text{gen}} = T_0 \left[\dot{m}_R(s_2 - s_1) + \dot{m}_{\text{air}}(s_4 - s_3) - \frac{\dot{Q}_{\text{in}}}{T_0} \right] \\ &= (305 \text{ K}) \left[(2 \text{ kg/min})(0.94789 - 0.34925) \text{ kJ/kg} \cdot \text{K} + (6.969 \text{ kg/min})(-0.1384 \text{ kJ/kg} \cdot \text{K}) - \frac{30 \text{ kJ/min}}{305 \text{ K}} \right] \\ &= 40.99 \text{ kJ/min} = \mathbf{0.683 \text{ kW}} \end{aligned}$$

8-65E Refrigerant-134a is evaporated in the evaporator of a refrigeration system. the rate of cooling provided, the rate of exergy destruction, and the second-law efficiency of the evaporator are to be determined.

Assumptions 1 This is a steady-flow process since there is no change with time. **2** Kinetic and potential energy changes are negligible.

Analysis (a) The rate of cooling provided is

$$\dot{Q}_L = \dot{m}(h_2 - h_1) = (0.08 \text{ lbm/s})(172.1 - 107.5) \text{ Btu/lbm} = 5.162 \text{ Btu/s} = \mathbf{18,580 \text{ Btu/h}}$$

(b) The entropy generation and the exergy destruction are

$$\begin{aligned} \dot{S}_{\text{gen}} &= \dot{m}(s_2 - s_1) - \frac{\dot{Q}_L}{T_L} \\ &= (0.08 \text{ lbm/s})(0.4225 - 0.2851) \text{ Btu/lbm} \cdot \text{R} - \frac{5.162 \text{ Btu/s}}{(50 + 460) \text{ R}} \\ &= 0.0008691 \text{ Btu/s} \cdot \text{R} \end{aligned}$$

$$\dot{X}_{\text{dest}} = T_0 \dot{S}_{\text{gen}} = (537 \text{ R})(0.0008691 \text{ Btu/s} \cdot \text{R}) = \mathbf{0.4667 \text{ Btu/s}}$$

(c) The exergy supplied (or expended) during this cooling process is the exergy decrease of the refrigerant as it evaporates in the evaporator:

$$\begin{aligned} \dot{X}_1 - \dot{X}_2 &= \dot{m}(h_1 - h_2) - \dot{m}T_0(s_1 - s_2) \\ &= -5.162 - (0.08 \text{ lbm/s})(537 \text{ R})(0.2851 - 0.4225) \text{ Btu/lbm} \cdot \text{R} \\ &= 0.7400 \text{ Btu/s} \end{aligned}$$

The exergy efficiency is then

$$\eta_{\text{II, Evap}} = 1 - \frac{\dot{X}_{\text{dest}}}{\dot{X}_1 - \dot{X}_2} = 1 - \frac{0.4667}{0.7400} = 0.3693 = \mathbf{36.9\%}$$

8-66 A rigid tank initially contains saturated liquid of refrigerant-134a. R-134a is released from the vessel until no liquid is left in the vessel. The exergy destruction associated with this process is to be determined.

Assumptions 1 This is an unsteady process since the conditions within the device are changing during the process. It can be analyzed as a uniform-flow process since the state of fluid leaving the device remains constant. **2** Kinetic and potential energies are negligible. **3** There are no work interactions involved.

Properties The properties of R-134a are (Tables A-11 through A-13)

$$\begin{array}{l}
 T_1 = 24^\circ\text{C} \\
 \text{sat. liquid}
 \end{array}
 \left.
 \begin{array}{l}
 v_1 = v_f @ 24^\circ\text{C} = 0.0008260 \text{ m}^3/\text{kg} \\
 u_1 = u_f @ 24^\circ\text{C} = 84.44 \text{ kJ/kg} \\
 s_1 = s_f @ 24^\circ\text{C} = 0.31959 \text{ kJ/kg}\cdot\text{K}
 \end{array}
 \right\}$$

$$\begin{array}{l}
 T_2 = 24^\circ\text{C} \\
 \text{sat. vapor}
 \end{array}
 \left.
 \begin{array}{l}
 v_2 = v_g @ 24^\circ\text{C} = 0.031869 \text{ m}^3/\text{kg} \\
 u_2 = u_g @ 24^\circ\text{C} = 243.13 \text{ kJ/kg} \\
 s_2 = s_e = s_g @ 24^\circ\text{C} = 0.92107 \text{ kJ/kg}\cdot\text{K} \\
 h_e = h_g @ 24^\circ\text{C} = 263.72 \text{ kJ/kg}
 \end{array}
 \right\}$$

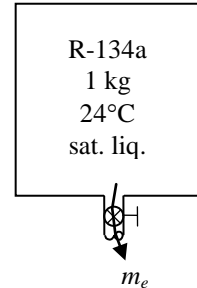

Analysis The volume of the container is

$$V = m_1 v_1 = (1 \text{ kg})(0.0008260 \text{ m}^3/\text{kg}) = 0.0008260 \text{ m}^3$$

The mass in the container at the final state is

$$m_2 = \frac{V}{v_2} = \frac{0.0008260 \text{ m}^3}{0.031869 \text{ m}^3/\text{kg}} = 0.02592 \text{ kg}$$

The amount of mass leaving the container is

$$m_e = m_1 - m_2 = 1 - 0.02592 = 0.9741 \text{ kg}$$

The exergy destroyed during a process can be determined from an exergy balance or directly from its definition $X_{\text{destroyed}} = T_0 S_{\text{gen}}$. The entropy generation S_{gen} in this case is determined from an entropy balance on the system:

$$\underbrace{S_{\text{in}} - S_{\text{out}}}_{\substack{\text{Net entropy transfer} \\ \text{by heat and mass}}} + \underbrace{S_{\text{gen}}}_{\substack{\text{Entropy} \\ \text{generation}}} = \underbrace{\Delta S_{\text{system}}}_{\substack{\text{Change} \\ \text{in entropy}}}$$

$$-m_e s_e + S_{\text{gen}} = \Delta S_{\text{tank}} = (m_2 s_2 - m_1 s_1)_{\text{tank}}$$

$$S_{\text{gen}} = m_2 s_2 - m_1 s_1 + m_e s_e$$

Substituting,

$$\begin{aligned}
 X_{\text{destroyed}} &= T_0 S_{\text{gen}} = T_0 (m_2 s_2 - m_1 s_1 + m_e s_e) \\
 &= (297 \text{ K})(0.02592 \times 0.92107 - 1 \times 0.31959 + 0.9741 \times 0.92107) \\
 &= \mathbf{179 \text{ kJ}}
 \end{aligned}$$

8-67E An adiabatic rigid tank that is initially evacuated is filled by air from a supply line. The work potential associated with this process is to be determined.

Assumptions 1 This is an unsteady process since the conditions within the device are changing during the process. It can be analyzed as a uniform-flow process since the state of fluid entering the device remains constant. **2** Kinetic and potential energies are negligible. **3** There are no work interactions involved. **4** Air is an ideal gas with constant specific heats.

Properties The properties of air at room temperature are $c_p = 0.240$ Btu/lbm·R, $k = 1.4$, and $R = 0.06855$ Btu/lbm·R = 0.3704 kPa·m³/lbm·R (Table A-2Ea).

Analysis We take the tank as the system, which is a control volume since mass crosses the boundary. Noting that the microscopic energies of flowing and nonflowing fluids are represented by enthalpy h and internal energy u , respectively, the mass and energy balances for this uniform-flow system can be expressed as

Mass balance:

$$m_{\text{in}} - m_{\text{out}} = \Delta m_{\text{system}} \rightarrow m_i = m_2$$

Energy balance:

$$\underbrace{E_{\text{in}} - E_{\text{out}}}_{\substack{\text{Net energy transfer} \\ \text{by heat, work, and mass}}} = \underbrace{\Delta E_{\text{system}}}_{\substack{\text{Change in internal, kinetic,} \\ \text{potential, etc. energies}}}$$

$$m_i h_i = m_2 u_2$$

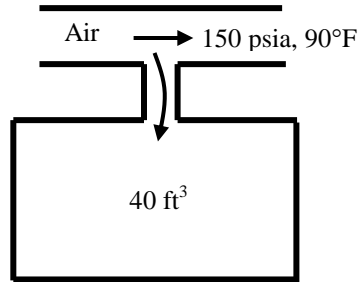

Combining the two balances:

$$h_i = u_2 \longrightarrow c_p T_i = c_v T_2 \longrightarrow T_2 = \frac{c_p}{c_v} T_i = k T_i$$

Substituting,

$$T_2 = k T_i = (1.4)(550 \text{ R}) = 770 \text{ R}$$

The final mass in the tank is

$$m_2 = m_i = \frac{P V}{R T_2} = \frac{(150 \text{ psia})(40 \text{ ft}^3)}{(0.3704 \text{ psia} \cdot \text{ft}^3/\text{lbm} \cdot \text{R})(770 \text{ R})} = 21.04 \text{ lbm}$$

The work potential associated with this process is equal to the exergy destroyed during the process. The exergy destruction during a process can be determined from an exergy balance or directly from its definition $X_{\text{destroyed}} = T_0 S_{\text{gen}}$. The entropy generation S_{gen} in this case is determined from an entropy balance on the system:

$$\underbrace{S_{\text{in}} - S_{\text{out}}}_{\substack{\text{Net entropy transfer} \\ \text{by heat and mass}}} + \underbrace{S_{\text{gen}}}_{\substack{\text{Entropy} \\ \text{generation}}} = \underbrace{\Delta S_{\text{system}}}_{\substack{\text{Change} \\ \text{in entropy}}}$$

$$m_i s_i + S_{\text{gen}} = \Delta S_{\text{tank}} = m_2 s_2$$

$$S_{\text{gen}} = m_2 s_2 - m_i s_i$$

$$S_{\text{gen}} = m_2 (s_2 - s_i)$$

Substituting,

$$W_{\text{rev}} = X_{\text{destroyed}} = m_2 T_0 (s_2 - s_i) = m_2 T_0 \left(c_p \ln \frac{T_2}{T_i} \right)$$

$$= (21.04 \text{ lbm})(540 \text{ R}) \left[(0.240 \text{ Btu/lbm} \cdot \text{R}) \ln \frac{770 \text{ R}}{550 \text{ R}} \right]$$

$$= \mathbf{917 \text{ Btu}}$$

8-68E An rigid tank that is initially evacuated is filled by air from a supply line. The work potential associated with this process is to be determined.

Assumptions 1 This is an unsteady process since the conditions within the device are changing during the process. It can be analyzed as a uniform-flow process since the state of fluid entering the device remains constant. **2** Kinetic and potential energies are negligible. **3** There are no work interactions involved. **4** Air is an ideal gas with constant specific heats.

Properties The properties of air at room temperature are $c_p = 0.240$ Btu/lbm·R and $R = 0.06855$ Btu/lbm·R = 0.3704 kPa·m³/lbm·R (Table A-2Ea).

Analysis We take the tank as the system, which is a control volume since mass crosses the boundary. Noting that the microscopic energies of flowing and nonflowing fluids are represented by enthalpy h and internal energy u , respectively, the mass and energy balances for this uniform-flow system can be expressed as

$$\text{Mass balance: } m_{\text{in}} - m_{\text{out}} = \Delta m_{\text{system}} \rightarrow m_i = m_2$$

Energy balance:

$$\underbrace{E_{\text{in}} - E_{\text{out}}}_{\substack{\text{Net energy transfer} \\ \text{by heat, work, and mass}}} = \underbrace{\Delta E_{\text{system}}}_{\substack{\text{Change in internal, kinetic,} \\ \text{potential, etc. energies}}}$$

$$m_i h_i - Q_{\text{out}} = m_2 u_2$$

$$Q_{\text{out}} = m_i h_i - m_2 u_2$$

Combining the two balances:

$$Q_{\text{out}} = m_2 (h_i - u_2)$$

The final mass in the tank is

$$m_2 = m_i = \frac{P\mathcal{V}}{RT_2} = \frac{(150 \text{ psia})(40 \text{ ft}^3)}{(0.3704 \text{ psia} \cdot \text{ft}^3/\text{lbm} \cdot \text{R})(550 \text{ R})} = 29.45 \text{ lbm}$$

Substituting,

$$Q_{\text{out}} = m_2 (h_i - u_2) = m_2 (c_p T_i - c_v T_i) = m_2 T_i (c_p - c_v) = m_2 T_i R$$

$$= (29.45 \text{ lbm})(550 \text{ R})(0.06855 \text{ Btu/lbm} \cdot \text{R})$$

$$= 1110 \text{ Btu}$$

The work potential associated with this process is equal to the exergy destroyed during the process. The exergy destruction during a process can be determined from an exergy balance or directly from its definition $X_{\text{destroyed}} = T_0 S_{\text{gen}}$. The entropy generation S_{gen} in this case is determined from an entropy balance on the system:

$$\underbrace{S_{\text{in}} - S_{\text{out}}}_{\substack{\text{Net entropy transfer} \\ \text{by heat and mass}}} + \underbrace{S_{\text{gen}}}_{\substack{\text{Entropy} \\ \text{generation}}} = \underbrace{\Delta S_{\text{system}}}_{\substack{\text{Change} \\ \text{in entropy}}}$$

$$m_i s_i - \frac{Q_{\text{out}}}{T_0} + S_{\text{gen}} = \Delta S_{\text{tank}} = m_2 s_2$$

$$S_{\text{gen}} = m_2 s_2 - m_i s_i + \frac{Q_{\text{out}}}{T_0}$$

$$S_{\text{gen}} = m_2 (s_2 - s_i) + \frac{Q_{\text{out}}}{T_0}$$

Noting that both the temperature and pressure in the tank is same as those in the supply line at the final state, substituting gives,

$$W_{\text{rev}} = X_{\text{destroyed}} = T_0 \left[m_2 (s_2 - s_i) + \frac{Q_{\text{out}}}{T_0} \right]$$

$$= T_0 \left(0 + \frac{Q_{\text{out}}}{T_0} \right) = T_0 \left(\frac{Q_{\text{out}}}{T_0} \right) = Q_{\text{out}}$$

$$= \mathbf{1110 \text{ Btu}}$$

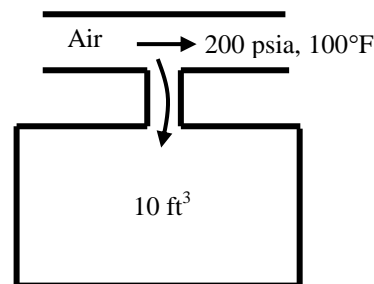

8-69 Steam expands in a turbine steadily at a specified rate from a specified state to another specified state. The power potential of the steam at the inlet conditions and the reversible power output are to be determined.

Assumptions 1 This is a steady-flow process since there is no change with time. **2** Kinetic and potential energy changes are negligible. **3** The temperature of the surroundings is given to be 25°C.

Properties From the steam tables (Tables A-4 through 6)

$$\left. \begin{array}{l} P_1 = 7 \text{ MPa} \\ T_1 = 600^\circ\text{C} \end{array} \right\} \begin{array}{l} h_1 = 3650.6 \text{ kJ/kg} \\ s_1 = 7.0910 \text{ kJ/kg} \cdot \text{K} \end{array}$$

$$\left. \begin{array}{l} P_2 = 50 \text{ kPa} \\ \text{sat. vapor} \end{array} \right\} \begin{array}{l} h_2 = 2645.2 \text{ kJ/kg} \\ s_2 = 7.5931 \text{ kJ/kg} \cdot \text{K} \end{array}$$

$$\left. \begin{array}{l} P_0 = 100 \text{ kPa} \\ T_0 = 25^\circ\text{C} \end{array} \right\} \begin{array}{l} h_0 \cong h_f @ 25^\circ\text{C} = 104.83 \text{ kJ/kg} \\ s_0 \cong s_f @ 25^\circ\text{C} = 0.36723 \text{ kJ/kg} \cdot \text{K} \end{array}$$

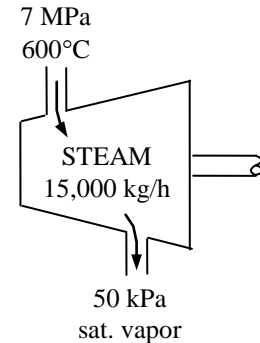

Analysis (a) The power potential of the steam at the inlet conditions is equivalent to its exergy at the inlet state,

$$\begin{aligned} \dot{\Psi} &= \dot{m}\psi_1 = \dot{m} \left(h_1 - h_0 - T_0(s_1 - s_0) + \frac{V_1^2}{2} + gz_1 \right) = \dot{m}(h_1 - h_0 - T_0(s_1 - s_0)) \\ &= (18,000 / 3600 \text{ kg/s})[(3650.6 - 104.83) \text{ kJ/kg} - (298 \text{ K})(7.0910 - 0.36723) \text{ kJ/kg} \cdot \text{K}] \\ &= \mathbf{7710 \text{ kW}} \end{aligned}$$

(b) The power output of the turbine if there were no irreversibilities is the reversible power, is determined from the rate form of the exergy balance applied on the turbine and setting the exergy destruction term equal to zero,

$$\begin{aligned} \underbrace{\dot{X}_{\text{in}} - \dot{X}_{\text{out}}}_{\text{Rate of net exergy transfer by heat, work, and mass}} - \underbrace{\dot{X}_{\text{destroyed}}^{\text{reversible}}}_{\text{Rate of exergy destruction}} &= \underbrace{\Delta \dot{X}_{\text{system}}^{\text{steady}}}_{\text{Rate of change of exergy}} = 0 \\ \dot{X}_{\text{in}} &= \dot{X}_{\text{out}} \\ \dot{m}\psi_1 &= \dot{W}_{\text{rev,out}} + \dot{m}\psi_2 \\ \dot{W}_{\text{rev,out}} &= \dot{m}(\psi_1 - \psi_2) = \dot{m}[(h_1 - h_2) - T_0(s_1 - s_2) - \Delta ke^{\text{re}} - \Delta pe^{\text{re}}] \end{aligned}$$

Substituting,

$$\begin{aligned} \dot{W}_{\text{rev,out}} &= \dot{m}[(h_1 - h_2) - T_0(s_1 - s_2)] \\ &= (15,000/3600 \text{ kg/s})[(3650.6 - 2645.2) \text{ kJ/kg} - (298 \text{ K})(7.0910 - 7.5931) \text{ kJ/kg} \cdot \text{K}] \\ &= \mathbf{5775 \text{ kW}} \end{aligned}$$

8-70E Air is compressed steadily by a 400-hp compressor from a specified state to another specified state while being cooled by the ambient air. The mass flow rate of air and the part of input power that is used to just overcome the irreversibilities are to be determined.

Assumptions 1 Air is an ideal gas with variable specific heats. **2** Potential energy changes are negligible. **3** The temperature of the surroundings is given to be 60°F.

Properties The gas constant of air is $R = 0.06855 \text{ Btu/lbm}\cdot\text{R}$ (Table A-1E). From the air table (Table A-17E)

$$T_1 = 520 \text{ R} \quad \left. \begin{array}{l} h_1 = 124.27 \text{ Btu/lbm} \\ s_1^o = 0.59173 \text{ Btu/lbm}\cdot\text{R} \end{array} \right\}$$

$$T_2 = 1080 \text{ R} \quad \left. \begin{array}{l} h_2 = 260.97 \text{ Btu/lbm} \\ s_2^o = 0.76964 \text{ Btu/lbm}\cdot\text{R} \end{array} \right\}$$

Analysis (a) There is only one inlet and one exit, and thus $\dot{m}_1 = \dot{m}_2 = \dot{m}$.

We take the actual compressor as the system, which is a control volume.

The energy balance for this steady-flow system can be expressed as

$$\underbrace{\dot{E}_{\text{in}} - \dot{E}_{\text{out}}}_{\substack{\text{Rate of net energy transfer} \\ \text{by heat, work, and mass}}} = \underbrace{\Delta\dot{E}_{\text{system}}}_{\substack{\text{Rate of change in internal, kinetic,} \\ \text{potential, etc. energies}}} \stackrel{\neq 0}{\text{(steady)}} = 0$$

$$\dot{E}_{\text{in}} = \dot{E}_{\text{out}}$$

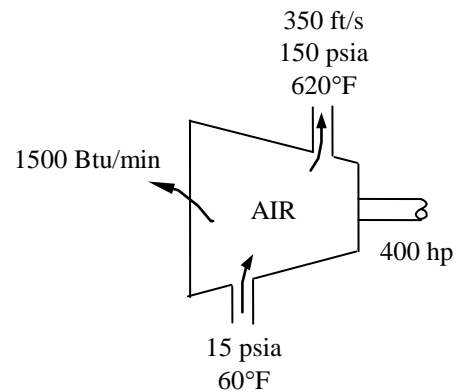

$$\dot{W}_{a,\text{in}} + \dot{m}(h_1 + V_1^2/2) = \dot{m}(h_2 + V_2^2/2) + \dot{Q}_{\text{out}} \rightarrow \dot{W}_{a,\text{in}} - \dot{Q}_{\text{out}} = \dot{m} \left(h_2 - h_1 + \frac{V_2^2 - V_1^2}{2} \right)$$

Substituting, the mass flow rate of the refrigerant becomes

$$(400 \text{ hp}) \left(\frac{0.7068 \text{ Btu/s}}{1 \text{ hp}} \right) - (1500/60 \text{ Btu/s}) = \dot{m} \left(260.97 - 124.27 + \frac{(350 \text{ ft/s})^2 - 0}{2} \frac{1 \text{ Btu/lbm}}{25,037 \text{ ft}^2/\text{s}^2} \right)$$

It yields

$$\dot{m} = 1.852 \text{ lbm/s}$$

(b) The portion of the power output that is used just to overcome the irreversibilities is equivalent to exergy destruction, which can be determined from an exergy balance or directly from its definition $\dot{X}_{\text{destroyed}} = T_0 \dot{S}_{\text{gen}}$ where the entropy generation \dot{S}_{gen} is determined from an entropy balance on an *extended system* that includes the device and its immediate surroundings. It gives

$$\underbrace{\dot{S}_{\text{in}} - \dot{S}_{\text{out}}}_{\substack{\text{Rate of net entropy transfer} \\ \text{by heat and mass}}} + \underbrace{\dot{S}_{\text{gen}}}_{\substack{\text{Rate of entropy} \\ \text{generation}}} = \underbrace{\Delta\dot{S}_{\text{system}}}_{\substack{\text{Rate of change} \\ \text{of entropy}}} \stackrel{\neq 0}{=} 0$$

$$\dot{m}s_1 - \dot{m}s_2 - \frac{\dot{Q}_{\text{out}}}{T_{\text{b,surr}}} + \dot{S}_{\text{gen}} = 0 \rightarrow \dot{S}_{\text{gen}} = \dot{m}(s_2 - s_1) + \frac{\dot{Q}_{\text{out}}}{T_0}$$

where

$$s_2 - s_1 = s_2^o - s_1^o - R \ln \frac{P_2}{P_1} = (0.76964 - 0.59173) \text{ Btu/lbm} - (0.06855 \text{ Btu/lbm}\cdot\text{R}) \ln \frac{150 \text{ psia}}{15 \text{ psia}} = 0.02007 \text{ Btu/lbm}\cdot\text{R}$$

Substituting, the exergy destruction is determined to be

$$\begin{aligned} \dot{X}_{\text{destroyed}} &= T_0 \dot{S}_{\text{gen}} = T_0 \left(\dot{m}(s_2 - s_1) + \frac{\dot{Q}_{\text{out}}}{T_0} \right) \\ &= (520 \text{ R}) \left((1.852 \text{ lbm/s})(0.02007 \text{ Btu/lbm}\cdot\text{R}) + \frac{1500/60 \text{ Btu/s}}{520 \text{ R}} \right) \left(\frac{1 \text{ hp}}{0.7068 \text{ Btu/s}} \right) = 62.72 \text{ hp} \end{aligned}$$

8-71 Hot combustion gases are accelerated in an adiabatic nozzle. The exit velocity and the decrease in the exergy of the gases are to be determined.

Assumptions 1 This is a steady-flow process since there is no change with time. **2** Potential energy changes are negligible. **3** The device is adiabatic and thus heat transfer is negligible. **4** The combustion gases are ideal gases with constant specific heats.

Properties The constant pressure specific heat and the specific heat ratio are given to be $c_p = 1.15 \text{ kJ/kg}\cdot\text{K}$ and $k = 1.3$. The gas constant R is determined from

$$R = c_p - c_v = c_p - c_p / k = c_p (1 - 1/k) = (1.15 \text{ kJ/kg}\cdot\text{K})(1 - 1/1.3) = 0.2654 \text{ kJ/kg}\cdot\text{K}$$

Analysis (a) There is only one inlet and one exit, and thus $\dot{m}_1 = \dot{m}_2 = \dot{m}$. We take the nozzle as the system, which is a control volume. The energy balance for this steady-flow system can be expressed as

$$\underbrace{\dot{E}_{\text{in}} - \dot{E}_{\text{out}}}_{\substack{\text{Rate of net energy transfer} \\ \text{by heat, work, and mass}}} = \underbrace{\Delta \dot{E}_{\text{system}}^{\text{no}}}_{\substack{\text{Rate of change in internal, kinetic,} \\ \text{potential, etc. energies}}} \stackrel{\text{no (steady)}}{=} 0$$

$$\dot{E}_{\text{in}} = \dot{E}_{\text{out}}$$

$$\dot{m}(h_1 + V_1^2/2) = \dot{m}(h_2 + V_2^2/2) \quad (\text{since } \dot{W} = \dot{Q} \cong \Delta p e \cong 0)$$

$$h_2 = h_1 - \frac{V_2^2 - V_1^2}{2}$$

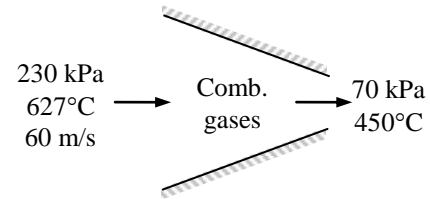

Then the exit velocity becomes

$$\begin{aligned} V_2 &= \sqrt{2c_p(T_1 - T_2) + V_1^2} \\ &= \sqrt{2(1.15 \text{ kJ/kg}\cdot\text{K})(627 - 450)\text{K} \left(\frac{1000 \text{ m}^2/\text{s}^2}{1 \text{ kJ/kg}} \right) + (60 \text{ m/s})^2} \\ &= \mathbf{641 \text{ m/s}} \end{aligned}$$

(b) The decrease in exergy of combustion gases is simply the difference between the initial and final values of flow exergy, and is determined to be

$$\psi_1 - \psi_2 = w_{\text{rev}} = h_1 - h_2 - \Delta ke - \Delta p e^{\text{no}} + T_0(s_2 - s_1) = c_p(T_1 - T_2) + T_0(s_2 - s_1) - \Delta ke$$

where

$$\Delta ke = \frac{V_2^2 - V_1^2}{2} = \frac{(641 \text{ m/s})^2 - (60 \text{ m/s})^2}{2} \left(\frac{1 \text{ kJ/kg}}{1000 \text{ m}^2/\text{s}^2} \right) = 203.6 \text{ kJ/kg}$$

and

$$\begin{aligned} s_2 - s_1 &= c_p \ln \frac{T_2}{T_1} - R \ln \frac{P_2}{P_1} \\ &= (1.15 \text{ kJ/kg}\cdot\text{K}) \ln \frac{723 \text{ K}}{900 \text{ K}} - (0.2654 \text{ kJ/kg}\cdot\text{K}) \ln \frac{70 \text{ kPa}}{230 \text{ kPa}} \\ &= 0.06386 \text{ kJ/kg}\cdot\text{K} \end{aligned}$$

Substituting,

$$\begin{aligned} \text{Decrease in exergy} &= \psi_1 - \psi_2 \\ &= (1.15 \text{ kJ/kg}\cdot\text{K})(627 - 450)^\circ\text{C} + (293 \text{ K})(0.06386 \text{ kJ/kg}\cdot\text{K}) - 203.6 \text{ kJ/kg} \\ &= \mathbf{18.7 \text{ kJ/kg}} \end{aligned}$$

8-72 Steam is accelerated in an adiabatic nozzle. The exit velocity of the steam, the isentropic efficiency, and the exergy destroyed within the nozzle are to be determined.

Assumptions 1 The nozzle operates steadily. 2 The changes in potential energies are negligible.

Properties The properties of steam at the inlet and the exit of the nozzle are (Tables A-4 through A-6)

$$\left. \begin{aligned} P_1 &= 7 \text{ MPa} \\ T_1 &= 500^\circ\text{C} \end{aligned} \right\} \begin{aligned} h_1 &= 3411.4 \text{ kJ/kg} \\ s_1 &= 6.8000 \text{ kJ/kg}\cdot\text{K} \end{aligned}$$

$$\left. \begin{aligned} P_2 &= 5 \text{ MPa} \\ T_2 &= 450^\circ\text{C} \end{aligned} \right\} \begin{aligned} h_2 &= 3317.2 \text{ kJ/kg} \\ s_2 &= 6.8210 \text{ kJ/kg}\cdot\text{K} \end{aligned}$$

$$\left. \begin{aligned} P_{2s} &= 5 \text{ MPa} \\ s_{2s} &= s_1 \end{aligned} \right\} h_{2s} = 3302.0 \text{ kJ/kg}$$

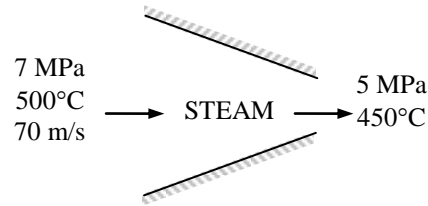

Analysis (a) We take the nozzle to be the system, which is a control volume. The energy balance for this steady-flow system can be expressed in the rate form as

$$\underbrace{\dot{E}_{\text{in}} - \dot{E}_{\text{out}}}_{\text{Rate of net energy transfer by heat, work, and mass}} = \underbrace{\dot{\Delta E}_{\text{system}}}_{\text{Rate of change in internal, kinetic, potential, etc. energies}} \stackrel{\neq 0}{\text{(steady)}} = 0$$

$$\dot{E}_{\text{in}} = \dot{E}_{\text{out}}$$

$$\dot{m}(h_1 + V_1^2/2) = \dot{m}(h_2 + V_2^2/2) \quad (\text{since } \dot{W} = \dot{Q} \cong \Delta p e \cong 0)$$

$$0 = h_2 - h_1 + \frac{V_2^2 - V_1^2}{2}$$

Then the exit velocity becomes

$$V_2 = \sqrt{2(h_1 - h_2) + V_1^2} = \sqrt{2(3411.4 - 3317.2) \text{ kJ/kg} \left(\frac{1000 \text{ m}^2/\text{s}^2}{1 \text{ kJ/kg}} \right) + (70 \text{ m/s})^2} = \mathbf{439.6 \text{ m/s}}$$

(b) The exit velocity for the isentropic case is determined from

$$V_{2s} = \sqrt{2(h_1 - h_{2s}) + V_1^2} = \sqrt{2(3411.4 - 3302.0) \text{ kJ/kg} \left(\frac{1000 \text{ m}^2/\text{s}^2}{1 \text{ kJ/kg}} \right) + (70 \text{ m/s})^2} = 472.9 \text{ m/s}$$

Thus,

$$\eta_N = \frac{V_2^2/2}{V_{2s}^2/2} = \frac{(439.6 \text{ m/s})^2/2}{(472.9 \text{ m/s})^2/2} = \mathbf{86.4\%}$$

(c) The exergy destroyed during a process can be determined from an exergy balance or directly from its definition $X_{\text{destroyed}} = T_0 S_{\text{gen}}$ where the entropy generation S_{gen} is determined from an entropy balance on the actual nozzle. It gives

$$\underbrace{\dot{S}_{\text{in}} - \dot{S}_{\text{out}}}_{\text{Rate of net entropy transfer by heat and mass}} + \underbrace{\dot{S}_{\text{gen}}}_{\text{Rate of entropy generation}} = \underbrace{\dot{\Delta S}_{\text{system}}}_{\text{Rate of change of entropy}} \stackrel{\neq 0}{=} 0$$

$$\dot{m}s_1 - \dot{m}s_2 + \dot{S}_{\text{gen}} = 0 \rightarrow \dot{S}_{\text{gen}} = \dot{m}(s_2 - s_1) \quad \text{or} \quad s_{\text{gen}} = s_2 - s_1$$

Substituting, the exergy destruction in the nozzle on a unit mass basis is determined to be

$$x_{\text{destroyed}} = T_0 s_{\text{gen}} = T_0 (s_2 - s_1) = (298 \text{ K})(6.8210 - 6.8000) \text{ kJ/kg}\cdot\text{K} = \mathbf{6.28 \text{ kJ/kg}}$$

8-73 Air is compressed in a steady-flow device isentropically. The work done, the exit exergy of compressed air, and the exergy of compressed air after it is cooled to ambient temperature are to be determined.

Assumptions 1 Air is an ideal gas with constant specific heats at room temperature. **2** The process is given to be reversible and adiabatic, and thus isentropic. Therefore, isentropic relations of ideal gases apply. **3** The environment temperature and pressure are given to be 300 K and 100 kPa. **4** The kinetic and potential energies are negligible.

Properties The gas constant of air is $R = 0.287 \text{ kJ/kg}\cdot\text{K}$ (Table A-1). The constant pressure specific heat and specific heat ratio of air at room temperature are $c_p = 1.005 \text{ kJ/kg}\cdot\text{K}$ and $k = 1.4$ (Table A-2).

Analysis (a) From the constant specific heats ideal gas isentropic relations,

$$T_2 = T_1 \left(\frac{P_2}{P_1} \right)^{(k-1)/k} = (300 \text{ K}) \left(\frac{800 \text{ kPa}}{100 \text{ kPa}} \right)^{0.4/1.4} = 543.4 \text{ K}$$

For a steady-flow isentropic compression process, the work input is determined from

$$\begin{aligned} w_{\text{comp,in}} &= \frac{kRT_1}{k-1} \left\{ \left(P_2/P_1 \right)^{(k-1)/k} - 1 \right\} \\ &= \frac{(1.4)(0.287 \text{ kJ/kg}\cdot\text{K})(300 \text{ K})}{1.4-1} \left\{ (800/100)^{0.4/1.4} - 1 \right\} \\ &= \mathbf{244.5 \text{ kJ/kg}} \end{aligned}$$

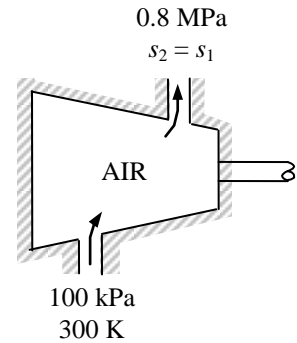

(b) The exergy of air at the compressor exit is simply the flow exergy at the exit state,

$$\begin{aligned} \psi_2 &= h_2 - h_0 - T_0(s_2 - s_0) + \frac{V_2^2}{2} + gz_2 \quad (\text{since the process } 0-2 \text{ is isentropic}) \\ &= c_p(T_2 - T_0) \\ &= (1.005 \text{ kJ/kg}\cdot\text{K})(543.4 - 300) \text{ K} = \mathbf{244.7 \text{ kJ/kg}} \end{aligned}$$

which is practically the same as the compressor work input. This is not surprising since the compression process is reversible.

(c) The exergy of compressed air at 0.8 MPa after it is cooled to 300 K is again the flow exergy at that state,

$$\begin{aligned} \psi_3 &= h_3 - h_0 - T_0(s_3 - s_0) + \frac{V_3^2}{2} + gz_3 \\ &= c_p(T_3 - T_0) - T_0(s_3 - s_0) \quad (\text{since } T_3 = T_0 = 300 \text{ K}) \\ &= -T_0(s_3 - s_0) \end{aligned}$$

where

$$s_3 - s_0 = c_p \ln \frac{T_3}{T_0} - R \ln \frac{P_3}{P_0} = -R \ln \frac{P_3}{P_0} = -(0.287 \text{ kJ/kg}\cdot\text{K}) \ln \frac{800 \text{ kPa}}{100 \text{ kPa}} = -0.5968 \text{ kJ/kg}\cdot\text{K}$$

Substituting,

$$\psi_3 = -(300 \text{ K})(-0.5968 \text{ kJ/kg}\cdot\text{K}) = \mathbf{179 \text{ kJ/kg}}$$

Note that the exergy of compressed air decreases from 245 to 179 kJ/kg as it is cooled to ambient temperature.

8-74 A rigid tank initially contains saturated liquid water. A valve at the bottom of the tank is opened, and half of mass in liquid form is withdrawn from the tank. The temperature in the tank is maintained constant. The amount of heat transfer, the reversible work, and the exergy destruction during this process are to be determined.

Assumptions 1 This is an unsteady process since the conditions within the device are changing during the process, but it can be analyzed as a uniform-flow process since the state of fluid leaving the device remains constant. **2** Kinetic and potential energies are negligible. **3** There are no work interactions involved. **4** The direction of heat transfer is to the tank (will be verified).

Properties The properties of water are (Tables A-4 through A-6)

$$T_1 = 170^\circ\text{C} \left\{ \begin{array}{l} \nu_1 = \nu_{f@170^\circ\text{C}} = 0.001114 \text{ m}^3/\text{kg} \\ u_1 = u_{f@170^\circ\text{C}} = 718.20 \text{ kJ/kg} \\ s_1 = s_{f@170^\circ\text{C}} = 2.0417 \text{ kJ/kg}\cdot\text{K} \end{array} \right.$$

$$T_e = 170^\circ\text{C} \left\{ \begin{array}{l} h_e = h_{f@170^\circ\text{C}} = 719.08 \text{ kJ/kg} \\ s_e = s_{f@170^\circ\text{C}} = 2.0417 \text{ kJ/kg}\cdot\text{K} \end{array} \right.$$

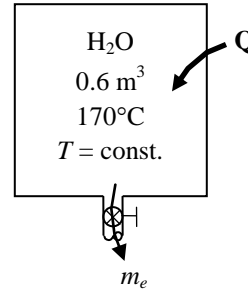

Analysis We take the tank as the system, which is a control volume since mass crosses the boundary. Noting that the microscopic energies of flowing and nonflowing fluids are represented by enthalpy h and internal energy u , respectively, the mass and energy balances for this uniform-flow system can be expressed as

Mass balance:

$$m_{\text{in}} - m_{\text{out}} = \Delta m_{\text{system}} \rightarrow m_e = m_1 - m_2$$

Energy balance:

$$\underbrace{E_{\text{in}} - E_{\text{out}}}_{\substack{\text{Net energy transfer} \\ \text{by heat, work, and mass}}} = \underbrace{\Delta E_{\text{system}}}_{\substack{\text{Change in internal, kinetic,} \\ \text{potential, etc. energies}}}$$

$$Q_{\text{in}} = m_e h_e + m_2 u_2 - m_1 u_1 \quad (\text{since } W \cong \text{ke} \cong \text{pe} \cong 0)$$

The initial and the final masses in the tank are

$$m_1 = \frac{\nu}{\nu_1} = \frac{0.6 \text{ m}^3}{0.001114 \text{ m}^3/\text{kg}} = 538.47 \text{ kg}$$

$$m_2 = \frac{1}{2} m_1 = \frac{1}{2} (538.47 \text{ kg}) = 269.24 \text{ kg} = m_e$$

Now we determine the final internal energy and entropy,

$$\nu_2 = \frac{\nu}{m_2} = \frac{0.6 \text{ m}^3}{269.24 \text{ kg}} = 0.002229 \text{ m}^3/\text{kg}$$

$$x_2 = \frac{\nu_2 - \nu_f}{\nu_{fg}} = \frac{0.002229 - 0.001114}{0.24260 - 0.001114} = 0.004614$$

$$T_2 = 170^\circ\text{C} \left\{ \begin{array}{l} u_2 = u_f + x_2 u_{fg} = 718.20 + (0.004614)(1857.5) = 726.77 \text{ kJ/kg} \\ s_2 = s_f + x_2 s_{fg} = 2.0417 + (0.004614)(4.6233) = 2.0630 \text{ kJ/kg}\cdot\text{K} \end{array} \right.$$

The heat transfer during this process is determined by substituting these values into the energy balance equation,

$$Q_{\text{in}} = m_e h_e + m_2 u_2 - m_1 u_1$$

$$= (269.24 \text{ kg})(719.08 \text{ kJ/kg}) + (269.24 \text{ kg})(726.77 \text{ kJ/kg}) - (538.47 \text{ kg})(718.20 \text{ kJ/kg})$$

$$= \mathbf{2545 \text{ kJ}}$$

(b) The exergy destroyed during a process can be determined from an exergy balance or directly from its definition $X_{\text{destroyed}} = T_0 S_{\text{gen}}$. The entropy generation S_{gen} in this case is determined from an entropy balance on an *extended system* that includes the tank and the region between the tank and the source so that the boundary temperature of the extended system at the location of heat transfer is the source temperature T_{source} at all times. It gives

$$\underbrace{S_{\text{in}} - S_{\text{out}}}_{\substack{\text{Net entropy transfer} \\ \text{by heat and mass}}} + \underbrace{S_{\text{gen}}}_{\substack{\text{Entropy} \\ \text{generation}}} = \underbrace{\Delta S_{\text{system}}}_{\substack{\text{Change} \\ \text{in entropy}}}$$

$$\frac{Q_{\text{in}}}{T_{\text{b,in}}} - m_e s_e + S_{\text{gen}} = \Delta S_{\text{tank}} = (m_2 s_2 - m_1 s_1)_{\text{tank}}$$

$$S_{\text{gen}} = m_2 s_2 - m_1 s_1 + m_e s_e - \frac{Q_{\text{in}}}{T_{\text{source}}}$$

Substituting, the exergy destruction is determined to be

$$\begin{aligned} X_{\text{destroyed}} &= T_0 S_{\text{gen}} = T_0 \left[m_2 s_2 - m_1 s_1 + m_e s_e - \frac{Q_{\text{in}}}{T_{\text{source}}} \right] \\ &= (298 \text{ K}) [269.24 \times 2.0630 - 538.47 \times 2.0417 + 269.24 \times 2.0417 - (2545 \text{ kJ}) / (523 \text{ K})] \\ &= \mathbf{141.2 \text{ kJ}} \end{aligned}$$

For processes that involve no actual work, the reversible work output and exergy destruction are identical. Therefore,

$$X_{\text{destroyed}} = W_{\text{rev,out}} - W_{\text{act,out}} \rightarrow W_{\text{rev,out}} = X_{\text{destroyed}} = \mathbf{141.2 \text{ kJ}}$$

8-75 A rigid tank initially contains saturated liquid-vapor mixture of refrigerant-134a. A valve at the bottom of the tank is opened, and liquid is withdrawn from the tank at constant pressure until no liquid remains inside. The final mass in the tank and the reversible work associated with this process are to be determined.

Assumptions 1 This is an unsteady process since the conditions within the device are changing during the process. It can be analyzed as a uniform-flow process since the state of fluid leaving the device remains constant. **2** Kinetic and potential energies are negligible. **3** There are no work interactions involved. **4** The direction of heat transfer is to the tank (will be verified).

Properties The properties of R-134a are (Tables A-11 through A-13)

$$P_1 = 800 \text{ kPa} \rightarrow \nu_f = 0.0008457 \text{ m}^3/\text{kg}, \nu_g = 0.025645 \text{ m}^3/\text{kg}$$

$$u_f = 94.80 \text{ kJ/kg}, u_g = 246.82 \text{ kJ/kg}$$

$$s_f = 0.35408 \text{ kJ/kg}\cdot\text{K}, s_g = 0.91853 \text{ kJ/kg}\cdot\text{K}$$

$$P_2 = 800 \text{ kPa} \left\{ \begin{array}{l} \nu_2 = \nu_g @ 800\text{kPa} = 0.025645 \text{ m}^3/\text{kg} \\ u_2 = u_g @ 800\text{kPa} = 246.82 \text{ kJ/kg} \\ s_2 = s_g @ 800\text{kPa} = 0.91853 \text{ kJ/kg}\cdot\text{K} \end{array} \right.$$

$$P_e = 800 \text{ kPa} \left\{ \begin{array}{l} h_e = h_f @ 800\text{kPa} = 95.48 \text{ kJ/kg} \\ s_e = s_f @ 800\text{kPa} = 0.35408 \text{ kJ/kg}\cdot\text{K} \end{array} \right.$$

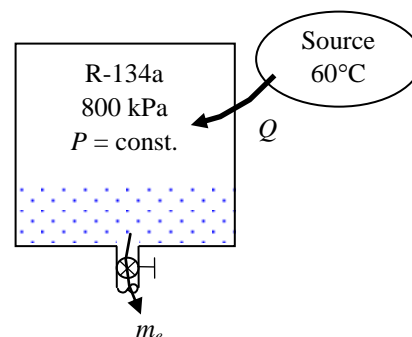

Analysis (b) We take the tank as the system, which is a control volume. Noting that the microscopic energies of flowing and nonflowing fluids are represented by enthalpy h and internal energy u , respectively, the mass and energy balances for this uniform-flow system can be expressed as

Mass balance: $m_{\text{in}} - m_{\text{out}} = \Delta m_{\text{system}} \rightarrow m_e = m_1 - m_2$

Energy balance:
$$\underbrace{E_{\text{in}} - E_{\text{out}}}_{\substack{\text{Net energy transfer} \\ \text{by heat, work, and mass}}} = \underbrace{\Delta E_{\text{system}}}_{\substack{\text{Change in internal, kinetic,} \\ \text{potential, etc. energies}}}$$

$$Q_{\text{in}} = m_e h_e + m_2 u_2 - m_1 u_1 \quad (\text{since } W \cong \text{ke} \cong \text{pe} \cong 0)$$

The initial mass, initial internal energy, and final mass in the tank are

$$m_1 = m_f + m_g = \frac{\nu_f}{\nu_f} + \frac{\nu_g}{\nu_g} = \frac{0.1 \times 0.3 \text{ m}^3}{0.0008457 \text{ m}^3/\text{kg}} + \frac{0.1 \times 0.7 \text{ m}^3}{0.025645 \text{ m}^3/\text{kg}} = 35.472 + 2.730 = 38.202 \text{ kg}$$

$$U_1 = m_1 u_1 = m_f u_f + m_g u_g = 35.472 \times 94.80 + 2.730 \times 246.82 = 4036.4 \text{ kJ}$$

$$S_1 = m_1 s_1 = m_f s_f + m_g s_g = 35.472 \times 0.35408 + 2.730 \times 0.91853 = 15.067 \text{ kJ/K}$$

$$m_2 = \frac{\nu}{\nu_2} = \frac{0.1 \text{ m}^3}{0.025645 \text{ m}^3/\text{kg}} = \mathbf{3.899 \text{ kg}}$$

Then from the mass and energy balances,

$$m_e = m_1 - m_2 = 38.202 - 3.899 = 34.30 \text{ kg}$$

$$Q_{\text{in}} = (34.30 \text{ kg})(95.48 \text{ kJ/kg}) + (3.899 \text{ kg})(246.82 \text{ kJ/kg}) - 4036.4 \text{ kJ} = 201.0 \text{ kJ}$$

(b) This process involves no actual work, thus the reversible work and exergy generation are identical since $X_{\text{destroyed}} = W_{\text{rev,out}} - W_{\text{act,out}} \rightarrow W_{\text{rev,out}} = X_{\text{destroyed}}$.

The exergy destroyed during a process can be determined from an exergy balance or directly from its definition $X_{\text{destroyed}} = T_0 S_{\text{gen}}$. The entropy generation S_{gen} in this case is determined from an entropy balance on an *extended system* that includes the tank and the region between the tank and the heat source so that the boundary temperature of the extended system at the location of heat transfer is the source temperature T_{source} at all times. It gives

$$\underbrace{S_{\text{in}} - S_{\text{out}}}_{\substack{\text{Net entropy transfer} \\ \text{by heat and mass}}} + \underbrace{S_{\text{gen}}}_{\substack{\text{Entropy} \\ \text{generation}}} = \underbrace{\Delta S_{\text{system}}}_{\substack{\text{Change} \\ \text{in entropy}}}$$

$$\frac{Q_{\text{in}}}{T_{\text{b,in}}} - m_e s_e + S_{\text{gen}} = \Delta S_{\text{tank}} = (m_2 s_2 - m_1 s_1)_{\text{tank}}$$

$$S_{\text{gen}} = m_2 s_2 - m_1 s_1 + m_e s_e - \frac{Q_{\text{in}}}{T_{\text{source}}}$$

Substituting,

$$\begin{aligned} W_{\text{rev,out}} = X_{\text{destroyed}} &= T_0 S_{\text{gen}} = T_0 \left[m_2 s_2 - m_1 s_1 + m_e s_e - \frac{Q_{\text{in}}}{T_{\text{source}}} \right] \\ &= (298 \text{ K}) [3.899 \times 0.91853 - 15.067 + 34.30 \times 0.35408 - 201.0 / 333] \\ &= \mathbf{16.85 \text{ kJ}} \end{aligned}$$

That is, 16.85 kJ of work could have been produced during this process.

8-76E An insulated rigid tank equipped with an electric heater initially contains pressurized air. A valve is opened, and air is allowed to escape at constant temperature until the pressure inside drops to 20 psia. The amount of electrical work done and the exergy destroyed are to be determined.

Assumptions 1 This is an unsteady process since the conditions within the device are changing during the process, but it can be analyzed as a uniform-flow process since the exit temperature (and enthalpy) of air remains constant. **2** Kinetic and potential energies are negligible. **3** The tank is insulated and thus heat transfer is negligible. **4** Air is an ideal gas with variable specific heats. **5** The environment temperature is given to be 70°F.

Properties The gas constant of air is $R = 0.3704 \text{ psia}\cdot\text{ft}^3/\text{lbm}\cdot\text{R}$ (Table A-1E). The properties of air are (Table A-17E)

$$T_e = 640 \text{ R} \longrightarrow h_e = 153.09 \text{ Btu/lbm}$$

$$T_1 = 640 \text{ R} \longrightarrow u_1 = 109.21 \text{ Btu/lbm} \quad T_2 = 640 \text{ R} \longrightarrow u_2 = 109.21 \text{ Btu/lbm}$$

Analysis We take the tank as the system, which is a control volume. Noting that the microscopic energies of flowing and nonflowing fluids are represented by enthalpy h and internal energy u , respectively, the mass and energy balances for this uniform-flow system can be expressed as

$$\text{Mass balance:} \quad m_{\text{in}} - m_{\text{out}} = \Delta m_{\text{system}} \rightarrow m_e = m_1 - m_2$$

Energy balance:

$$\underbrace{E_{\text{in}} - E_{\text{out}}}_{\substack{\text{Net energy transfer} \\ \text{by heat, work, and mass}}} = \underbrace{\Delta E_{\text{system}}}_{\substack{\text{Change in internal, kinetic,} \\ \text{potential, etc. energies}}}$$

$$W_{e,\text{in}} - m_e h_e = m_2 u_2 - m_1 u_1 \quad (\text{since } Q \cong ke \cong pe \cong 0)$$

The initial and the final masses of air in the tank are

$$m_1 = \frac{P_1 V}{RT_1} = \frac{(40 \text{ psia})(260 \text{ ft}^3)}{(0.3704 \text{ psia}\cdot\text{ft}^3/\text{lbm}\cdot\text{R})(640 \text{ R})} = 43.86 \text{ lbm}$$

$$m_2 = \frac{P_2 V}{RT_2} = \frac{(20 \text{ psia})(260 \text{ ft}^3)}{(0.3704 \text{ psia}\cdot\text{ft}^3/\text{lbm}\cdot\text{R})(640 \text{ R})} = 21.93 \text{ lbm}$$

Then from the mass and energy balances,

$$m_e = m_1 - m_2 = 43.86 - 21.93 = 21.93 \text{ lbm}$$

$$W_{e,\text{in}} = m_e h_e + m_2 u_2 - m_1 u_1$$

$$= (21.93 \text{ lbm})(153.09 \text{ Btu/lbm}) + (21.93 \text{ lbm})(109.21 \text{ Btu/lbm}) - (43.86 \text{ lbm})(109.21 \text{ Btu/lbm})$$

$$= \mathbf{962 \text{ Btu}}$$

(b) The exergy destroyed during a process can be determined from an exergy balance or directly from its definition $X_{\text{destroyed}} = T_0 S_{\text{gen}}$ where the entropy generation S_{gen} is determined from an entropy balance on the insulated tank.

It gives

$$\underbrace{S_{\text{in}} - S_{\text{out}}}_{\substack{\text{Net entropy transfer} \\ \text{by heat and mass}}} + \underbrace{S_{\text{gen}}}_{\substack{\text{Entropy} \\ \text{generation}}} = \underbrace{\Delta S_{\text{system}}}_{\substack{\text{Change} \\ \text{in entropy}}}$$

$$-m_e s_e + S_{\text{gen}} = \Delta S_{\text{tank}} = (m_2 s_2 - m_1 s_1)_{\text{tank}}$$

$$S_{\text{gen}} = m_2 s_2 - m_1 s_1 + m_e s_e$$

$$= m_2 s_2 - m_1 s_1 + (m_1 - m_2) s_e$$

$$= m_2 (s_2 - s_e) - m_1 (s_1 - s_e)$$

Assuming a constant average pressure of $(40 + 20) / 2 = 30 \text{ psia}$ for the exit stream, the entropy changes are determined to be

$$s_2 - s_e = c_p \ln \frac{T_2}{T_e} - R \ln \frac{P_2}{P_e} = -(0.06855 \text{ Btu/lbm}\cdot\text{R}) \ln \frac{20 \text{ psia}}{30 \text{ psia}} = 0.02779 \text{ Btu/lbm}\cdot\text{R}$$

$$s_1 - s_e = c_p \ln \frac{T_1}{T_e} - R \ln \frac{P_1}{P_e} = -(0.06855 \text{ Btu/lbm}\cdot\text{R}) \ln \frac{40 \text{ psia}}{30 \text{ psia}} = -0.01972 \text{ Btu/lbm}\cdot\text{R}$$

Substituting, the exergy destruction is determined to be

$$X_{\text{destroyed}} = T_0 S_{\text{gen}} = T_0 [m_2 (s_2 - s_e) - m_1 (s_1 - s_e)]$$

$$= (530 \text{ R}) [(21.93 \text{ lbm})(0.02779 \text{ Btu/lbm}\cdot\text{R}) - (43.86 \text{ lbm})(-0.01972 \text{ Btu/lbm}\cdot\text{R})] = \mathbf{782 \text{ Btu}}$$

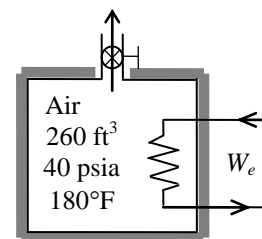

8-77 A cylinder initially contains helium gas at a specified pressure and temperature. A valve is opened, and helium is allowed to escape until its volume decreases by half. The work potential of the helium at the initial state and the exergy destroyed during the process are to be determined.

Assumptions 1 This is an unsteady process since the conditions within the device are changing during the process, but it can be analyzed as a uniform-flow process by using constant average properties for the helium leaving the tank. **2** Kinetic and potential energies are negligible. **3** There are no work interactions involved other than boundary work. **4** The tank is insulated and thus heat transfer is negligible. **5** Helium is an ideal gas with constant specific heats.

Properties The gas constant of helium is $R = 2.0769 \text{ kPa}\cdot\text{m}^3/\text{kg}\cdot\text{K} = 2.0769 \text{ kJ}/\text{kg}\cdot\text{K}$. The specific heats of helium are $c_p = 5.1926 \text{ kJ}/\text{kg}\cdot\text{K}$ and $c_v = 3.1156 \text{ kJ}/\text{kg}\cdot\text{K}$ (Table A-2).

Analysis (a) From the ideal gas relation, the initial and the final masses in the cylinder are determined to be

$$m_1 = \frac{P_1 V}{RT_1} = \frac{(200 \text{ kPa})(0.12 \text{ m}^3)}{(2.0769 \text{ kPa}\cdot\text{m}^3/\text{kg}\cdot\text{K})(293 \text{ K})} = 0.03944 \text{ kg}$$

$$m_e = m_2 = m_1 / 2 = 0.03944 / 2 = 0.01972 \text{ kg}$$

The work potential of helium at the initial state is simply the initial exergy of helium, and is determined from the closed-system exergy relation,

$$\Phi_1 = m_1 \phi = m_1 [(u_1 - u_0) - T_0 (s_1 - s_0) + P_0 (v_1 - v_0)]$$

where

$$v_1 = \frac{RT_1}{P_1} = \frac{(2.0769 \text{ kPa}\cdot\text{m}^3/\text{kg}\cdot\text{K})(293 \text{ K})}{200 \text{ kPa}} = 3.043 \text{ m}^3/\text{kg}$$

$$v_0 = \frac{RT_0}{P_0} = \frac{(2.0769 \text{ kPa}\cdot\text{m}^3/\text{kg}\cdot\text{K})(293 \text{ K})}{95 \text{ kPa}} = 6.406 \text{ m}^3/\text{kg}$$

and

$$\begin{aligned} s_1 - s_0 &= c_p \ln \frac{T_1}{T_0} - R \ln \frac{P_1}{P_0} \\ &= (5.1926 \text{ kJ}/\text{kg}\cdot\text{K}) \ln \frac{293 \text{ K}}{293 \text{ K}} - (2.0769 \text{ kJ}/\text{kg}\cdot\text{K}) \ln \frac{200 \text{ kPa}}{95 \text{ kPa}} \\ &= -1.546 \text{ kJ}/\text{kg}\cdot\text{K} \end{aligned}$$

Thus,

$$\begin{aligned} \Phi_1 &= (0.03944 \text{ kg}) \{ (3.1156 \text{ kJ}/\text{kg}\cdot\text{K})(20 - 20)^\circ\text{C} - (293 \text{ K})(-1.546 \text{ kJ}/\text{kg}\cdot\text{K}) \\ &\quad + (95 \text{ kPa})(3.043 - 6.406) \text{ m}^3/\text{kg} [\text{kJ}/\text{kPa}\cdot\text{m}^3] \} \\ &= \mathbf{5.27 \text{ kJ}} \end{aligned}$$

(b) We take the cylinder as the system, which is a control volume. Noting that the microscopic energies of flowing and nonflowing fluids are represented by enthalpy h and internal energy u , respectively, the mass and energy balances for this uniform-flow system can be expressed as

Mass balance:

$$m_{\text{in}} - m_{\text{out}} = \Delta m_{\text{system}} \rightarrow m_e = m_1 - m_2$$

Energy balance:

$$\begin{aligned} \underbrace{E_{\text{in}} - E_{\text{out}}}_{\text{Net energy transfer by heat, work, and mass}} &= \underbrace{\Delta E_{\text{system}}}_{\text{Change in internal, kinetic, potential, etc. energies}} \\ Q_{\text{in}} - m_e h_e + W_{\text{b,in}} &= m_2 u_2 - m_1 u_1 \end{aligned}$$

Combining the two relations gives

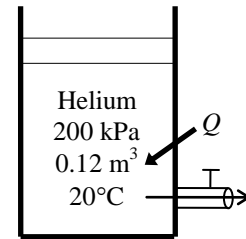

$$\begin{aligned}
 Q_{\text{in}} &= (m_1 - m_2)h_e + m_2u_2 - m_1u_1 - W_{\text{b,in}} \\
 &= (m_1 - m_2)h_e + m_2h_2 - m_1h_1 \\
 &= (m_1 - m_2 + m_2 - m_1)h_1 \\
 &= 0
 \end{aligned}$$

since the boundary work and ΔU combine into ΔH for constant pressure expansion and compression processes.

The exergy destroyed during a process can be determined from an exergy balance or directly from its definition $X_{\text{destroyed}} = T_0 S_{\text{gen}}$ where the entropy generation S_{gen} can be determined from an entropy balance on the cylinder.

Noting that the pressure and temperature of helium in the cylinder are maintained constant during this process and heat transfer is zero, it gives

$$\begin{aligned}
 \underbrace{S_{\text{in}} - S_{\text{out}}}_{\substack{\text{Net entropy transfer} \\ \text{by heat and mass}}} + \underbrace{S_{\text{gen}}}_{\substack{\text{Entropy} \\ \text{generation}}} &= \underbrace{\Delta S_{\text{system}}}_{\substack{\text{Change} \\ \text{in entropy}}} \\
 -m_e s_e + S_{\text{gen}} &= \Delta S_{\text{cylinder}} = (m_2 s_2 - m_1 s_1)_{\text{cylinder}} \\
 S_{\text{gen}} &= m_2 s_2 - m_1 s_1 + m_e s_e \\
 &= m_2 s_2 - m_1 s_1 + (m_1 - m_2) s_e \\
 &= (m_2 - m_1 + m_1 - m_2) s_1 \\
 &= 0
 \end{aligned}$$

since the initial, final, and the exit states are identical and thus $s_e = s_2 = s_1$. Therefore, this discharge process is reversible, and

$$X_{\text{destroyed}} = T_0 S_{\text{gen}} = \mathbf{0}$$

8-78 An insulated cylinder initially contains saturated liquid-vapor mixture of water. The cylinder is connected to a supply line, and the steam is allowed to enter the cylinder until all the liquid is vaporized. The amount of steam that entered the cylinder and the exergy destroyed are to be determined.

Assumptions 1 This is an unsteady process since the conditions within the device are changing during the process, but it can be analyzed as a uniform-flow process since the state of fluid at the inlet remains constant. **2** The expansion process is quasi-equilibrium. **3** Kinetic and potential energies are negligible. **4** The device is insulated and thus heat transfer is negligible.

Properties The properties of steam are (Tables A-4 through A-6)

$$\left. \begin{aligned} P_1 &= 300 \text{ kPa} \\ x_1 &= 13/15 = 0.8667 \end{aligned} \right\} \begin{aligned} h_1 &= h_f + x_1 h_{fg} = 561.43 + 0.8667 \times 2163.5 = 2436.5 \text{ kJ/kg} \\ s_1 &= s_f + x_1 s_{fg} = 1.6716 + 0.8667 \times 5.3200 = 6.2824 \text{ kJ/kg} \cdot \text{K} \end{aligned}$$

$$\left. \begin{aligned} P_2 &= 300 \text{ kPa} \\ \text{sat. vapor} \end{aligned} \right\} \begin{aligned} h_2 &= h_g @ 300 \text{ kPa} = 2724.9 \text{ kJ/kg} \\ s_2 &= s_g @ 300 \text{ kPa} = 6.9917 \text{ kJ/kg} \cdot \text{K} \end{aligned}$$

$$\left. \begin{aligned} P_i &= 2 \text{ MPa} \\ T_i &= 400^\circ \text{C} \end{aligned} \right\} \begin{aligned} h_i &= 3248.4 \text{ kJ/kg} \\ s_i &= 7.1292 \text{ kJ/kg} \cdot \text{K} \end{aligned}$$

Analysis (a) We take the cylinder as the system, which is a control volume. Noting that the microscopic energies of flowing and nonflowing fluids are represented by enthalpy h and internal energy u , respectively, the mass and energy balances for this unsteady-flow system can be expressed as

$$\text{Mass balance: } m_{\text{in}} - m_{\text{out}} = \Delta m_{\text{system}} \rightarrow m_i = m_2 - m_1$$

Energy balance:

$$\underbrace{E_{\text{in}} - E_{\text{out}}}_{\substack{\text{Net energy transfer} \\ \text{by heat, work, and mass}}} = \underbrace{\Delta E_{\text{system}}}_{\substack{\text{Change in internal, kinetic,} \\ \text{potential, etc. energies}}} \\ m_i h_i = W_{\text{b,out}} + m_2 u_2 - m_1 u_1 \quad (\text{since } Q \cong \text{ke} \cong \text{pe} \cong 0)$$

$$\text{Combining the two relations gives } 0 = W_{\text{b,out}} - (m_2 - m_1)h_i + m_2 u_2 - m_1 u_1$$

$$\text{or, } 0 = -(m_2 - m_1)h_i + m_2 h_2 - m_1 h_1$$

since the boundary work and ΔU combine into ΔH for constant pressure expansion and compression processes. Solving for m_2 and substituting,

$$m_2 = \frac{h_i - h_1}{h_i - h_2} m_1 = \frac{(3248.4 - 2436.5) \text{ kJ/kg}}{(3248.4 - 2724.9) \text{ kJ/kg}} (15 \text{ kg}) = 23.27 \text{ kg}$$

$$\text{Thus, } m_i = m_2 - m_1 = 23.27 - 15 = \mathbf{8.27 \text{ kg}}$$

(b) The exergy destroyed during a process can be determined from an exergy balance or directly from its definition $X_{\text{destroyed}} = T_0 S_{\text{gen}}$ where the entropy generation S_{gen} is determined from an entropy balance on the insulated cylinder,

$$\underbrace{S_{\text{in}} - S_{\text{out}}}_{\substack{\text{Net entropy transfer} \\ \text{by heat and mass}}} + \underbrace{S_{\text{gen}}}_{\substack{\text{Entropy} \\ \text{generation}}} = \underbrace{\Delta S_{\text{system}}}_{\substack{\text{Change} \\ \text{in entropy}}} \\ m_i s_i + S_{\text{gen}} = \Delta S_{\text{system}} = m_2 s_2 - m_1 s_1 \\ S_{\text{gen}} = m_2 s_2 - m_1 s_1 - m_i s_i$$

Substituting, the exergy destruction is determined to be

$$\begin{aligned} X_{\text{destroyed}} &= T_0 S_{\text{gen}} = T_0 [m_2 s_2 - m_1 s_1 - m_i s_i] \\ &= (298 \text{ K})(23.27 \times 6.9917 - 15 \times 6.2824 - 8.27 \times 7.1292) \\ &= \mathbf{2832 \text{ kJ}} \end{aligned}$$

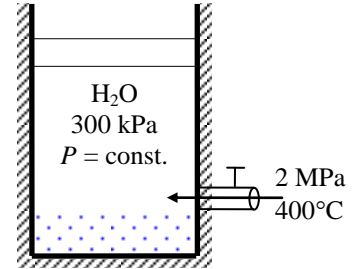

8-79 Each member of a family of four takes a shower every day. The amount of exergy destroyed by this family per year is to be determined.

Assumptions 1 Steady operating conditions exist. 2 The kinetic and potential energies are negligible. 3 Heat losses from the pipes, mixing section are negligible and thus $\dot{Q} \cong 0$. 4 Showers operate at maximum flow conditions during the entire shower. 5 Each member of the household takes a shower every day. 6 Water is an incompressible substance with constant properties at room temperature. 7 The efficiency of the electric water heater is 100%.

Properties The density and specific heat of water at room temperature are $\rho = 997 \text{ kg/m}^3$ and $c = 4.18 \text{ kJ/kg}\cdot^\circ\text{C}$ (Table A-3).

Analysis The mass flow rate of water at the shower head is

$$\dot{m} = \rho \dot{V} = (0.997 \text{ kg/L})(10 \text{ L/min}) = 9.97 \text{ kg/min}$$

The mass balance for the mixing chamber can be expressed in the rate form as

$$\dot{m}_{\text{in}} - \dot{m}_{\text{out}} = \Delta \dot{m}_{\text{system}} \stackrel{\approx 0 \text{ (steady)}}{=} 0 \rightarrow \dot{m}_{\text{in}} = \dot{m}_{\text{out}} \rightarrow \dot{m}_1 + \dot{m}_2 = \dot{m}_3$$

where the subscript 1 denotes the cold water stream, 2 the hot water stream, and 3 the mixture.

The rate of entropy generation during this process can be determined by applying the rate form of the entropy balance on a system that includes the electric water heater and the mixing chamber (the T-elbow). Noting that there is no entropy transfer associated with work transfer (electricity) and there is no heat transfer, the entropy balance for this steady-flow system can be expressed as

$$\underbrace{\dot{S}_{\text{in}} - \dot{S}_{\text{out}}}_{\substack{\text{Rate of net entropy transfer} \\ \text{by heat and mass}}} + \underbrace{\dot{S}_{\text{gen}}}_{\substack{\text{Rate of entropy} \\ \text{generation}}} = \underbrace{\Delta \dot{S}_{\text{system}}}_{\substack{\text{Rate of change} \\ \text{of entropy}}} \stackrel{\approx 0 \text{ (steady)}}{=} 0$$

$$\dot{m}_1 s_1 + \dot{m}_2 s_2 - \dot{m}_3 s_3 + \dot{S}_{\text{gen}} = 0 \quad (\text{since } Q = 0 \text{ and work is entropy free})$$

$$\dot{S}_{\text{gen}} = \dot{m}_3 s_3 - \dot{m}_1 s_1 - \dot{m}_2 s_2$$

Noting from mass balance that $\dot{m}_1 + \dot{m}_2 = \dot{m}_3$ and $s_2 = s_1$ since hot water enters the system at the same temperature as the cold water, the rate of entropy generation is determined to be

$$\begin{aligned} \dot{S}_{\text{gen}} &= \dot{m}_3 s_3 - (\dot{m}_1 + \dot{m}_2) s_1 = \dot{m}_3 (s_3 - s_1) = \dot{m}_3 c_p \ln \frac{T_3}{T_1} \\ &= (9.97 \text{ kg/min})(4.18 \text{ kJ/kg}\cdot\text{K}) \ln \frac{42 + 273}{15 + 273} = 3.735 \text{ kJ/min}\cdot\text{K} \end{aligned}$$

Noting that 4 people take a 6-min shower every day, the amount of entropy generated per year is

$$\begin{aligned} S_{\text{gen}} &= (\dot{S}_{\text{gen}}) \Delta t (\text{No. of people}) (\text{No. of days}) \\ &= (3.735 \text{ kJ/min}\cdot\text{K})(6 \text{ min/person}\cdot\text{day})(4 \text{ persons})(365 \text{ days/year}) \\ &= 32,715 \text{ kJ/K (per year)} \end{aligned}$$

The exergy destroyed during a process can be determined from an exergy balance or directly from its definition $X_{\text{destroyed}} = T_0 S_{\text{gen}}$,

$$X_{\text{destroyed}} = T_0 S_{\text{gen}} = (298 \text{ K})(32,715 \text{ kJ/K}) = \mathbf{9,749,000 \text{ kJ}}$$

Discussion The value above represents the exergy destroyed within the water heater and the T-elbow in the absence of any heat losses. It does not include the exergy destroyed as the shower water at 42°C is discarded or cooled to the outdoor temperature. Also, an entropy balance on the mixing chamber alone (hot water entering at 55°C instead of 15°C) will exclude the exergy destroyed within the water heater.

8-80 Cold water is heated by hot water in a heat exchanger. The rate of heat transfer and the rate of exergy destruction within the heat exchanger are to be determined.

Assumptions 1 Steady operating conditions exist. 2 The heat exchanger is well-insulated so that heat loss to the surroundings is negligible and thus heat transfer from the hot fluid is equal to the heat transfer to the cold fluid. 3 Changes in the kinetic and potential energies of fluid streams are negligible. 4 Fluid properties are constant. 5 The temperature of the environment is 25°C.

Properties The specific heats of cold and hot water are given to be 4.18 and 4.19 kJ/kg·°C, respectively.

Analysis We take the cold water tubes as the system, which is a control volume. The energy balance for this steady-flow system can be expressed in the rate form as

$$\underbrace{\dot{E}_{\text{in}} - \dot{E}_{\text{out}}}_{\text{Rate of net energy transfer by heat, work, and mass}} = \underbrace{\Delta \dot{E}_{\text{system}}^{\neq 0} (\text{steady})}_{\text{Rate of change in internal, kinetic, potential, etc. energies}} = 0$$

$$\dot{E}_{\text{in}} = \dot{E}_{\text{out}}$$

$$\dot{Q}_{\text{in}} + \dot{m}h_1 = \dot{m}h_2 \quad (\text{since } \Delta ke \cong \Delta pe \cong 0)$$

$$\dot{Q}_{\text{in}} = \dot{m}c_p(T_2 - T_1)$$

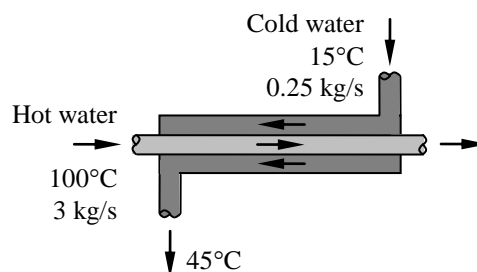

Then the rate of heat transfer to the cold water in this heat exchanger becomes

$$\dot{Q}_{\text{in}} = [\dot{m}c_p(T_{\text{out}} - T_{\text{in}})]_{\text{cold water}} = (0.25 \text{ kg/s})(4.18 \text{ kJ/kg}\cdot\text{°C})(45\text{°C} - 15\text{°C}) = \mathbf{31.35 \text{ kW}}$$

Noting that heat gain by the cold water is equal to the heat loss by the hot water, the outlet temperature of the hot water is determined to be

$$\dot{Q} = [\dot{m}c_p(T_{\text{in}} - T_{\text{out}})]_{\text{hot water}} \longrightarrow T_{\text{out}} = T_{\text{in}} - \frac{\dot{Q}}{\dot{m}c_p}$$

$$= 100\text{°C} - \frac{31.35 \text{ kW}}{(3 \text{ kg/s})(4.19 \text{ kJ/kg}\cdot\text{°C})} = \mathbf{97.5\text{°C}}$$

(b) The rate of entropy generation within the heat exchanger is determined by applying the rate form of the entropy balance on the entire heat exchanger:

$$\underbrace{\dot{S}_{\text{in}} - \dot{S}_{\text{out}}}_{\text{Rate of net entropy transfer by heat and mass}} + \underbrace{\dot{S}_{\text{gen}}}_{\text{Rate of entropy generation}} = \underbrace{\Delta \dot{S}_{\text{system}}^{\neq 0} (\text{steady})}_{\text{Rate of change of entropy}}$$

$$\dot{m}_1s_1 + \dot{m}_3s_3 - \dot{m}_2s_2 - \dot{m}_4s_4 + \dot{S}_{\text{gen}} = 0 \quad (\text{since } \dot{Q} = 0)$$

$$\dot{m}_{\text{cold}}s_1 + \dot{m}_{\text{hot}}s_3 - \dot{m}_{\text{cold}}s_2 - \dot{m}_{\text{hot}}s_4 + \dot{S}_{\text{gen}} = 0$$

$$\dot{S}_{\text{gen}} = \dot{m}_{\text{cold}}(s_2 - s_1) + \dot{m}_{\text{hot}}(s_4 - s_3)$$

Noting that both fluid streams are liquids (incompressible substances), the rate of entropy generation is determined to be

$$\dot{S}_{\text{gen}} = \dot{m}_{\text{cold}}c_p \ln \frac{T_2}{T_1} + \dot{m}_{\text{hot}}c_p \ln \frac{T_4}{T_3}$$

$$= (0.25 \text{ kg/s})(4.18 \text{ kJ/kg}\cdot\text{K}) \ln \frac{45 + 273}{15 + 273} + (3 \text{ kg/s})(4.19 \text{ kJ/kg}\cdot\text{K}) \ln \frac{97.5 + 273}{100 + 273}$$

$$= \mathbf{0.0190 \text{ kW/K}}$$

The exergy destroyed during a process can be determined from an exergy balance or directly from its definition $X_{\text{destroyed}} = T_0 S_{\text{gen}}$,

$$X_{\text{destroyed}} = T_0 S_{\text{gen}} = (298 \text{ K})(0.019 \text{ kW/K}) = \mathbf{5.66 \text{ kW}}$$

8-81 Air is preheated by hot exhaust gases in a cross-flow heat exchanger. The rate of heat transfer and the rate of exergy destruction in the heat exchanger are to be determined.

Assumptions 1 Steady operating conditions exist. **2** The heat exchanger is well-insulated so that heat loss to the surroundings is negligible and thus heat transfer from the hot fluid is equal to the heat transfer to the cold fluid. **3** Changes in the kinetic and potential energies of fluid streams are negligible. **4** Fluid properties are constant.

Properties The specific heats of air and combustion gases are given to be 1.005 and 1.10 kJ/kg·°C, respectively. The gas constant of air is $R = 0.287$ kJ/kg·K (Table A-1).

Analysis We take the exhaust pipes as the system, which is a control volume. The energy balance for this steady-flow system can be expressed in the rate form as

$$\underbrace{\dot{E}_{\text{in}} - \dot{E}_{\text{out}}}_{\substack{\text{Rate of net energy transfer} \\ \text{by heat, work, and mass}}} = \underbrace{\Delta \dot{E}_{\text{system}}}_{\substack{\text{Rate of change in internal, kinetic,} \\ \text{potential, etc. energies}}} \stackrel{\approx 0 \text{ (steady)}}{=} 0$$

$$\dot{E}_{\text{in}} = \dot{E}_{\text{out}}$$

$$\dot{m}h_1 = \dot{Q}_{\text{out}} + \dot{m}h_2 \quad (\text{since } \Delta \text{ke} \cong \Delta \text{pe} \cong 0)$$

$$\dot{Q}_{\text{out}} = \dot{m}c_p(T_1 - T_2)$$

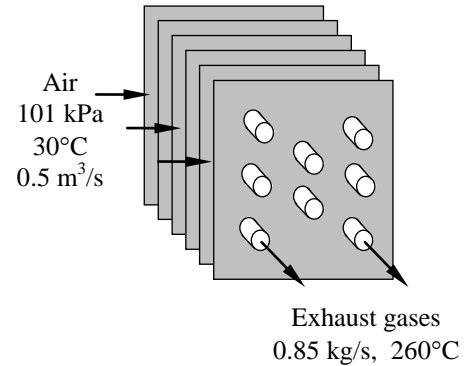

Then the rate of heat transfer from the exhaust gases becomes

$$\dot{Q} = [\dot{m}c_p(T_{\text{in}} - T_{\text{out}})]_{\text{gas}} = (0.85 \text{ kg/s})(1.1 \text{ kJ/kg}\cdot\text{°C})(350\text{°C} - 260\text{°C}) = \mathbf{84.15 \text{ kW}}$$

The mass flow rate of air is

$$\dot{m} = \frac{P\dot{V}}{RT} = \frac{(101 \text{ kPa})(0.5 \text{ m}^3/\text{s})}{(0.287 \text{ kPa}\cdot\text{m}^3/\text{kg}\cdot\text{K}) \times 303 \text{ K}} = 0.5807 \text{ kg/s}$$

Noting that heat loss by exhaust gases is equal to the heat gain by the air, the air exit temperature becomes

$$\dot{Q} = [\dot{m}c_p(T_{\text{out}} - T_{\text{in}})]_{\text{air}} \rightarrow T_{\text{out}} = T_{\text{in}} + \frac{\dot{Q}}{\dot{m}c_p} = 30\text{°C} + \frac{84.15 \text{ kW}}{(0.5807 \text{ kg/s})(1.005 \text{ kJ/kg}\cdot\text{°C})} = 174.2\text{°C}$$

The rate of entropy generation within the heat exchanger is determined by applying the rate form of the entropy balance on the entire heat exchanger:

$$\underbrace{\dot{S}_{\text{in}} - \dot{S}_{\text{out}}}_{\substack{\text{Rate of net entropy transfer} \\ \text{by heat and mass}}} + \underbrace{\dot{S}_{\text{gen}}}_{\substack{\text{Rate of entropy} \\ \text{generation}}} = \underbrace{\Delta \dot{S}_{\text{system}}}_{\substack{\text{Rate of change} \\ \text{of entropy}}} \stackrel{\approx 0 \text{ (steady)}}{=} 0$$

$$\dot{m}_1 s_1 + \dot{m}_3 s_3 - \dot{m}_2 s_2 - \dot{m}_4 s_4 + \dot{S}_{\text{gen}} = 0 \quad (\text{since } \dot{Q} = 0)$$

$$\dot{m}_{\text{exhaust}} s_1 + \dot{m}_{\text{air}} s_3 - \dot{m}_{\text{exhaust}} s_2 - \dot{m}_{\text{air}} s_4 + \dot{S}_{\text{gen}} = 0$$

$$\dot{S}_{\text{gen}} = \dot{m}_{\text{exhaust}}(s_2 - s_1) + \dot{m}_{\text{air}}(s_4 - s_3)$$

Noting that the pressure of each fluid remains constant in the heat exchanger, the rate of entropy generation is

$$\dot{S}_{\text{gen}} = \dot{m}_{\text{exhaust}} c_p \ln \frac{T_2}{T_1} + \dot{m}_{\text{air}} c_p \ln \frac{T_4}{T_3}$$

$$= (0.85 \text{ kg/s})(1.1 \text{ kJ/kg}\cdot\text{K}) \ln \frac{260 + 273}{350 + 273} + (0.5807 \text{ kg/s})(1.005 \text{ kJ/kg}\cdot\text{K}) \ln \frac{174.2 + 273}{30 + 273}$$

$$= 0.08129 \text{ kW/K}$$

The exergy destroyed during a process can be determined from an exergy balance or directly from its definition $X_{\text{destroyed}} = T_0 \dot{S}_{\text{gen}}$,

$$\dot{X}_{\text{destroyed}} = T_0 \dot{S}_{\text{gen}} = (303 \text{ K})(0.08129 \text{ kW/K}) = \mathbf{24.6 \text{ kW}}$$

8-82E Steam is condensed by cooling water in a condenser. The rate of heat transfer and the rate of exergy destruction within the heat exchanger are to be determined.

Assumptions 1 Steady operating conditions exist. 2 The heat exchanger is well-insulated so that heat loss to the surroundings is negligible and thus heat transfer from the hot fluid is equal to the heat transfer to the cold fluid. 3 Changes in the kinetic and potential energies of fluid streams are negligible. 4 Fluid properties are constant. 5 The temperature of the environment is 77°F.

Properties The specific heat of water is 1.0 Btu/lbm·°F (Table A-3E). The enthalpy and entropy of vaporization of water at 120°F are 1025.2 Btu/lbm and $s_{fg} = 1.7686$ Btu/lbm·R (Table A-4E).

Analysis We take the tube-side of the heat exchanger where cold water is flowing as the system, which is a control volume. The energy balance for this steady-flow system can be expressed in the rate form as

$$\underbrace{\dot{E}_{in} - \dot{E}_{out}}_{\substack{\text{Rate of net energy transfer} \\ \text{by heat, work, and mass}}} = \underbrace{\Delta \dot{E}_{system}^{\neq 0} \text{ (steady)}}_{\substack{\text{Rate of change in internal, kinetic,} \\ \text{potential, etc. energies}}} = 0$$

$$\dot{E}_{in} = \dot{E}_{out}$$

$$\dot{Q}_{in} + \dot{m}h_1 = \dot{m}h_2 \quad (\text{since } \Delta ke \cong \Delta pe \cong 0)$$

$$\dot{Q}_{in} = \dot{m}c_p(T_2 - T_1)$$

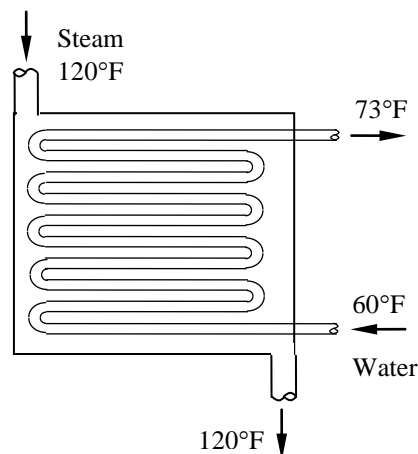

Then the rate of heat transfer to the cold water in this heat exchanger becomes

$$\dot{Q} = [\dot{m}c_p(T_{out} - T_{in})]_{\text{water}}$$

$$= (115.3 \text{ lbm/s})(1.0 \text{ Btu/lbm}\cdot\text{°F})(73\text{°F} - 60\text{°F}) = \mathbf{1499 \text{ Btu/s}}$$

Noting that heat gain by the water is equal to the heat loss by the condensing steam, the rate of condensation of the steam in the heat exchanger is determined from

$$\dot{Q} = (\dot{m}h_{fg})_{\text{steam}} = \dot{m}_{\text{steam}} h_{fg} = \frac{1499 \text{ Btu/s}}{1025.2 \text{ Btu/lbm}} = 1.462 \text{ lbm/s}$$

(b) The rate of entropy generation within the heat exchanger is determined by applying the rate form of the entropy balance on the entire heat exchanger:

$$\underbrace{\dot{S}_{in} - \dot{S}_{out}}_{\substack{\text{Rate of net entropy transfer} \\ \text{by heat and mass}}} + \underbrace{\dot{S}_{gen}}_{\substack{\text{Rate of entropy} \\ \text{generation}}} = \underbrace{\Delta \dot{S}_{system}^{\neq 0} \text{ (steady)}}_{\substack{\text{Rate of change} \\ \text{of entropy}}}$$

$$\dot{m}_1 s_1 + \dot{m}_3 s_3 - \dot{m}_2 s_2 - \dot{m}_4 s_4 + \dot{S}_{gen} = 0 \quad (\text{since } Q = 0)$$

$$\dot{m}_{\text{water}} s_1 + \dot{m}_{\text{steam}} s_3 - \dot{m}_{\text{water}} s_2 - \dot{m}_{\text{steam}} s_4 + \dot{S}_{gen} = 0$$

$$\dot{S}_{gen} = \dot{m}_{\text{water}}(s_2 - s_1) + \dot{m}_{\text{steam}}(s_4 - s_3)$$

Noting that water is an incompressible substance and steam changes from saturated vapor to saturated liquid, the rate of entropy generation is determined to be

$$\dot{S}_{gen} = \dot{m}_{\text{water}} c_p \ln \frac{T_2}{T_1} + \dot{m}_{\text{steam}}(s_f - s_g) = \dot{m}_{\text{water}} c_p \ln \frac{T_2}{T_1} - \dot{m}_{\text{steam}} s_{fg}$$

$$= (115.3 \text{ lbm/s})(1.0 \text{ Btu/lbm}\cdot\text{R}) \ln \frac{73 + 460}{60 + 460} - (1.462 \text{ lbm/s})(1.7686 \text{ Btu/lbm}\cdot\text{R}) = 0.2613 \text{ Btu/s}\cdot\text{R}$$

The exergy destroyed during a process can be determined from an exergy balance or directly from its definition $\dot{X}_{\text{destroyed}} = T_0 \dot{S}_{gen}$,

$$\dot{X}_{\text{destroyed}} = T_0 \dot{S}_{gen} = (537 \text{ R})(0.2613 \text{ Btu/s}\cdot\text{R}) = \mathbf{140.3 \text{ Btu/s}}$$

8-83 Air is compressed in a compressor that is intentionally cooled. The actual and reversible power inputs, the second law efficiency, and the mass flow rate of cooling water are to be determined.

Assumptions 1 Steady operating conditions exist. 2 Potential energy change is negligible. 3 Air is an ideal gas with constant specific heats.

Properties The gas constant of air is $R = 0.287 \text{ kJ/kg}\cdot\text{K}$ and the specific heat of air at room is $c_p = 1.005 \text{ kJ/kg}\cdot\text{K}$. the specific heat of water at room temperature is $c_w = 4.18 \text{ kJ/kg}\cdot\text{K}$ (Tables A-2, A-3).

Analysis (a) The mass flow rate of air is

$$\dot{m} = \rho \dot{V}_1 = \frac{P_1}{RT_1} \dot{V}_1 = \frac{(100 \text{ kPa})}{(0.287 \text{ kJ/kg}\cdot\text{K})(20 + 273 \text{ K})} (4.5 \text{ m}^3/\text{s}) = 5.351 \text{ kg/s}$$

The power input for a reversible-isothermal process is given by

$$\dot{W}_{\text{rev}} = \dot{m}RT_1 \ln \frac{P_2}{P_1} = (5.351 \text{ kg/s})(0.287 \text{ kJ/kg}\cdot\text{K})(20 + 273 \text{ K}) \ln \left(\frac{900 \text{ kPa}}{100 \text{ kPa}} \right) = \mathbf{988.8 \text{ kW}}$$

Given the isothermal efficiency, the actual power may be determined from

$$\dot{W}_{\text{actual}} = \frac{\dot{W}_{\text{rev}}}{\eta_T} = \frac{988.8 \text{ kW}}{0.70} = \mathbf{1413 \text{ kW}}$$

(b) The given isothermal efficiency is actually the second-law efficiency of the compressor

$$\eta_{\text{II}} = \eta_T = \mathbf{0.70}$$

(c) An energy balance on the compressor gives

$$\begin{aligned} \dot{Q}_{\text{out}} &= \dot{m} \left[c_p (T_1 - T_2) + \frac{V_1^2 - V_2^2}{2} \right] + \dot{W}_{\text{actual, in}} \\ &= (5.351 \text{ kg/s}) \left[(1.005 \text{ kJ/kg}\cdot\text{C})(20 - 60)\text{C} + \frac{0 - (80 \text{ m/s})^2}{2} \left(\frac{1 \text{ kJ/kg}}{1000 \text{ m}^2/\text{s}^2} \right) \right] + 1413 \text{ kW} \\ &= \mathbf{1181 \text{ kW}} \end{aligned}$$

The mass flow rate of the cooling water is

$$\dot{m}_w = \frac{\dot{Q}_{\text{out}}}{c_w \Delta T} = \frac{1181 \text{ kW}}{(4.18 \text{ kJ/kg}\cdot\text{C})(10\text{C})} = \mathbf{28.25 \text{ kg/s}}$$

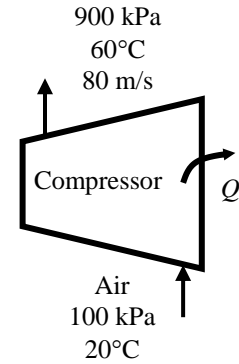

8-84E A hot water stream is mixed with a cold water stream. For a specified mixture temperature, the mass flow rate of cold water stream and the rate of exergy destruction are to be determined.

Assumptions 1 Steady operating conditions exist. 2 The mixing chamber is well-insulated so that heat loss to the surroundings is negligible. 3 Changes in the kinetic and potential energies of fluid streams are negligible.

Properties Noting that that $T < T_{\text{sat}@50 \text{ psia}} = 280.99^\circ\text{F}$, the water in all three streams exists as a compressed liquid, which can be approximated as a saturated liquid at the given temperature. Thus from Table A-4E,

$$\left. \begin{array}{l} P_1 = 50 \text{ psia} \\ T_1 = 160^\circ\text{F} \end{array} \right\} \begin{array}{l} h_1 \cong h_f @ 160^\circ\text{F} = 128.00 \text{ Btu/lbm} \\ s_1 \cong s_f @ 160^\circ\text{F} = 0.23136 \text{ Btu/lbm}\cdot\text{R} \end{array}$$

$$\left. \begin{array}{l} P_2 = 50 \text{ psia} \\ T_2 = 70^\circ\text{F} \end{array} \right\} \begin{array}{l} h_2 \cong h_f @ 70^\circ\text{F} = 38.08 \text{ Btu/lbm} \\ s_2 \cong s_f @ 70^\circ\text{F} = 0.07459 \text{ Btu/lbm}\cdot\text{R} \end{array}$$

$$\left. \begin{array}{l} P_3 = 50 \text{ psia} \\ T_3 = 110^\circ\text{F} \end{array} \right\} \begin{array}{l} h_3 \cong h_f @ 110^\circ\text{F} = 78.02 \text{ Btu/lbm} \\ s_3 \cong s_f @ 110^\circ\text{F} = 0.14728 \text{ Btu/lbm}\cdot\text{R} \end{array}$$

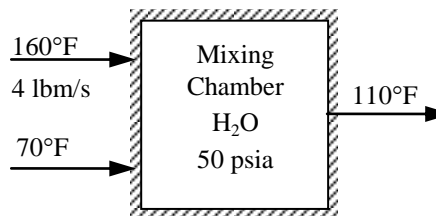

Analysis (a) We take the mixing chamber as the system, which is a control volume. The mass and energy balances for this steady-flow system can be expressed in the rate form as

$$\text{Mass balance: } \dot{m}_{\text{in}} - \dot{m}_{\text{out}} = \Delta \dot{m}_{\text{system}} \stackrel{\neq 0 \text{ (steady)}}{=} 0 \longrightarrow \dot{m}_1 + \dot{m}_2 = \dot{m}_3$$

Energy balance:

$$\underbrace{\dot{E}_{\text{in}} - \dot{E}_{\text{out}}}_{\text{Rate of net energy transfer by heat, work, and mass}} = \underbrace{\Delta \dot{E}_{\text{system}}}_{\text{Rate of change in internal, kinetic, potential, etc. energies}} \stackrel{\neq 0 \text{ (steady)}}{=} 0$$

$$\dot{E}_{\text{in}} = \dot{E}_{\text{out}}$$

$$\dot{m}_1 h_1 + \dot{m}_2 h_2 = \dot{m}_3 h_3 \quad (\text{since } \dot{Q} = \dot{W} = \Delta \text{ke} \cong \Delta \text{pe} \cong 0)$$

Combining the two relations gives

$$\dot{m}_1 h_1 + \dot{m}_2 h_2 = (\dot{m}_1 + \dot{m}_2) h_3$$

Solving for \dot{m}_2 and substituting, the mass flow rate of cold water stream is determined to be

$$\dot{m}_2 = \frac{h_1 - h_3}{h_3 - h_2} \dot{m}_1 = \frac{(128.00 - 78.02) \text{ Btu/lbm}}{(78.02 - 38.08) \text{ Btu/lbm}} (4.0 \text{ lbm/s}) = \mathbf{5.0 \text{ lbm/s}}$$

Also,

$$\dot{m}_3 = \dot{m}_1 + \dot{m}_2 = 4 + 5 = 9 \text{ lbm/s}$$

(b) The exergy destroyed during a process can be determined from an exergy balance or directly from its definition $\dot{X}_{\text{destroyed}} = T_0 \dot{S}_{\text{gen}}$ where the entropy generation \dot{S}_{gen} is determined from an entropy balance on the mixing chamber. It gives

$$\underbrace{\dot{S}_{\text{in}} - \dot{S}_{\text{out}}}_{\text{Rate of net entropy transfer by heat and mass}} + \underbrace{\dot{S}_{\text{gen}}}_{\text{Rate of entropy generation}} = \underbrace{\Delta \dot{S}_{\text{system}}}_{\text{Rate of change of entropy}} \stackrel{\neq 0}{=} 0$$

$$\dot{m}_1 s_1 + \dot{m}_2 s_2 - \dot{m}_3 s_3 + \dot{S}_{\text{gen}} = 0 \longrightarrow \dot{S}_{\text{gen}} = \dot{m}_3 s_3 - \dot{m}_1 s_1 - \dot{m}_2 s_2$$

Substituting, the exergy destruction is determined to be

$$\begin{aligned} \dot{X}_{\text{destroyed}} &= T_0 \dot{S}_{\text{gen}} = T_0 (\dot{m}_3 s_3 - \dot{m}_2 s_2 - \dot{m}_1 s_1) \\ &= (535 \text{ R})(9.0 \times 0.14728 - 5.0 \times 0.07459 - 4.0 \times 0.23136) \text{ Btu/s}\cdot\text{R} \\ &= \mathbf{14.7 \text{ Btu/s}} \end{aligned}$$

8-85 Water is heated in a chamber by mixing it with saturated steam. The temperature of the steam entering the chamber, the exergy destruction, and the second-law efficiency are to be determined.

Assumptions 1 Steady operating conditions exist. 2 Kinetic and potential energy changes are negligible. 3 Heat loss from the chamber is negligible.

Analysis (a) The properties of water are (Tables A-4 through A-6)

$$\left. \begin{array}{l} T_1 = 20^\circ\text{C} \\ x_1 = 0 \end{array} \right\} \begin{array}{l} h_1 = h_0 = 83.91 \text{ kJ/kg} \\ s_1 = s_0 = 0.29649 \text{ kJ/kg}\cdot\text{K} \end{array}$$

$$\left. \begin{array}{l} T_3 = 45^\circ\text{C} \\ x_3 = 0 \end{array} \right\} \begin{array}{l} h_3 = 188.44 \text{ kJ/kg} \\ s_3 = 0.63862 \text{ kJ/kg}\cdot\text{K} \end{array}$$

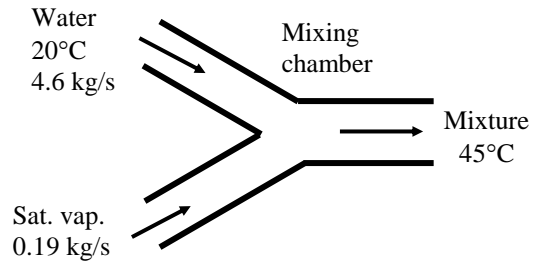

An energy balance on the chamber gives

$$\begin{aligned} \dot{m}_1 h_1 + \dot{m}_2 h_2 &= \dot{m}_3 h_3 = (\dot{m}_1 + \dot{m}_2) h_3 \\ (4.6 \text{ kg/s})(83.91 \text{ kJ/kg}) + (0.19 \text{ kg/s})h_2 &= (4.6 + 0.19 \text{ kg/s})(188.44 \text{ kJ/kg}) \\ h_2 &= 2719.0 \text{ kJ/kg} \end{aligned}$$

The remaining properties of the saturated steam are

$$\left. \begin{array}{l} h_2 = 2719.0 \text{ kJ/kg} \\ x_2 = 1 \end{array} \right\} \begin{array}{l} T_2 = \mathbf{129.2^\circ\text{C}} \\ s_2 = 7.0348 \text{ kJ/kg}\cdot\text{K} \end{array}$$

(b) The specific exergy of each stream is

$$\begin{aligned} \psi_1 &= 0 \\ \psi_2 &= h_2 - h_0 - T_0(s_2 - s_0) \\ &= (2719.0 - 83.91) \text{ kJ/kg} - (20 + 273 \text{ K})(7.0348 - 0.29649) \text{ kJ/kg}\cdot\text{K} \\ &= 660.7 \text{ kJ/kg} \\ \psi_3 &= h_3 - h_0 - T_0(s_3 - s_0) \\ &= (188.44 - 83.91) \text{ kJ/kg} - (20 + 273 \text{ K})(0.63862 - 0.29649) \text{ kJ/kg}\cdot\text{K} \\ &= 4.276 \text{ kJ/kg} \end{aligned}$$

The exergy destruction is determined from an exergy balance on the chamber to be

$$\begin{aligned} \dot{X}_{\text{dest}} &= \dot{m}_1 \psi_1 + \dot{m}_2 \psi_2 - (\dot{m}_1 + \dot{m}_2) \psi_3 \\ &= 0 + (0.19 \text{ kg/s})(660.7 \text{ kJ/kg}) - (4.6 + 0.19 \text{ kg/s})(4.276 \text{ kJ/kg}) \\ &= \mathbf{105.1 \text{ kW}} \end{aligned}$$

(c) The second-law efficiency for this mixing process may be determined from an “exergy recovered/exergy expended” approach as

$$\eta_{\text{II}} = \frac{\dot{X}_{\text{recovered}}}{\dot{X}_{\text{expended}}} = \frac{(\dot{X}_{\text{out}} - \dot{X}_{\text{in}})_{\text{cold}}}{(\dot{X}_{\text{in}} - \dot{X}_{\text{out}})_{\text{hot}}} = \frac{\dot{m}_{\text{cold}}(\psi_3 - \psi_1)}{\dot{m}_{\text{hot}}(\psi_2 - \psi_3)} = \frac{(4.6 \text{ kg/s})(4.276 - 0) \text{ kJ/kg}}{(0.19 \text{ kg/s})(660.7 - 4.276) \text{ kJ/kg}} = 0.1576 = \mathbf{15.8\%}$$

Discussion An alternative (and different) definition for the second-law efficiency for this mixing process may be determined from an “exergy out/exergy in” approach as

$$\eta_{\text{II}} = \frac{(\dot{m}_1 + \dot{m}_2) \psi_3}{\dot{m}_1 \psi_1 + \dot{m}_2 \psi_2} = \frac{(4.6 + 0.19 \text{ kg/s})(4.276 \text{ kJ/kg})}{0 + (0.19 \text{ kg/s})(660.7 \text{ kJ/kg})} = 0.1632 = 16.3\%$$

Review Problems

8-86E The second-law efficiency of a refrigerator and the refrigeration rate are given. The power input to the refrigerator is to be determined.

Analysis From the definition of the second-law efficiency, the COP of the refrigerator is determined to be

$$\text{COP}_{\text{R,rev}} = \frac{1}{T_H/T_L - 1} = \frac{1}{550/485 - 1} = 7.462$$

$$\eta_{\text{II}} = \frac{\text{COP}_{\text{R}}}{\text{COP}_{\text{R,rev}}} \longrightarrow \text{COP}_{\text{R}} = \eta_{\text{II}} \text{COP}_{\text{R,rev}} = 0.28 \times 7.462 = 2.089$$

Thus the power input is

$$\dot{W}_{\text{in}} = \frac{\dot{Q}_L}{\text{COP}_{\text{R}}} = \frac{800 \text{ Btu/min}}{2.089} \left(\frac{1 \text{ hp}}{42.41 \text{ Btu/min}} \right) = \mathbf{9.03 \text{ hp}}$$

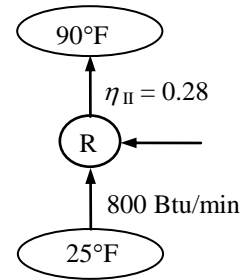

8-87 Refrigerant-134a is expanded adiabatically in an expansion valve. The work potential of R-134a at the inlet, the exergy destruction, and the second-law efficiency are to be determined.

Assumptions 1 Steady operating conditions exist. 2 Kinetic and potential energy changes are negligible.

Analysis (a) The properties of the refrigerant at the inlet and exit of the valve and at dead state are (Tables A-11 through A-13)

$$\begin{aligned} P_1 = 0.7 \text{ MPa} & \left. \begin{aligned} h_1 &= 86.42 \text{ kJ/kg} \\ T_1 = 25^\circ\text{C} & \left. \begin{aligned} s_1 &= 0.32429 \text{ kJ/kg}\cdot\text{K} \end{aligned} \right\} s_2 = 0.34131 \text{ kJ/kg}\cdot\text{K} \\ P_2 = 160 \text{ kPa} & \\ h_2 = h_1 = 86.42 \text{ kJ/kg} & \end{aligned} \right\} \\ P_0 = 100 \text{ kPa} & \left. \begin{aligned} h_0 &= 272.18 \text{ kJ/kg} \\ T_0 = 20^\circ\text{C} & \left. \begin{aligned} s_0 &= 1.0919 \text{ kJ/kg}\cdot\text{K} \end{aligned} \right\} \end{aligned} \right\} \end{aligned}$$

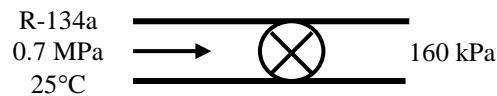

The specific exergy of the refrigerant at the inlet and exit of the valve are

$$\begin{aligned} \psi_1 &= h_1 - h_0 - T_0(s_1 - s_0) \\ &= (86.42 - 272.18) \text{ kJ/kg} - (20 + 273.15 \text{ K})(0.32429 - 1.0919) \text{ kJ/kg}\cdot\text{K} \\ &= \mathbf{39.25 \text{ kJ/kg}} \end{aligned}$$

$$\begin{aligned} \psi_2 &= h_2 - h_0 - T_0(s_2 - s_0) \\ &= (86.42 - 272.18) \text{ kJ/kg} - (20 + 273.15 \text{ K})(0.34131 - 1.0919) \text{ kJ/kg}\cdot\text{K} \\ &= 34.26 \text{ kJ/kg} \end{aligned}$$

(b) The exergy destruction is determined to be

$$\begin{aligned} x_{\text{dest}} &= T_0(s_2 - s_1) \\ &= (20 + 273.15 \text{ K})(0.34131 - 0.32429) \text{ kJ/kg}\cdot\text{K} \\ &= \mathbf{4.99 \text{ kJ/kg}} \end{aligned}$$

(c) The second-law efficiency can be determined from

$$\eta_{\text{II}} = \frac{x_{\text{recovered}}}{x_{\text{expended}}} = \frac{0}{\psi_1 - \psi_2} = \frac{0 \text{ kJ/kg}}{(39.25 - 34.26) \text{ kJ/kg}} = 0 = \mathbf{0\%}$$

Note that an expansion valve is a very wasteful device and it destroys all of the exergy expended in the process.

Discussion An alternative (and different) definition for the second-law efficiency of an expansion valve can be expressed using an “exergy out/exergy in” approach as

$$\eta_{\text{II}} = \frac{x_{\text{out}}}{x_{\text{in}}} = \frac{\psi_2}{\psi_1} = \frac{34.26 \text{ kJ/kg}}{39.25 \text{ kJ/kg}} = 0.873 = 87.3\%$$

8-88 Steam is accelerated in an adiabatic nozzle. The exit velocity, the rate of exergy destruction, and the second-law efficiency are to be determined.

Assumptions 1 Steady operating conditions exist. 2 Potential energy changes are negligible.

Analysis (a) The properties of the steam at the inlet and exit of the turbine and at the dead state are (Tables A-4 through A-6)

$$\begin{aligned} P_1 = 3.5 \text{ MPa} & \left\{ \begin{array}{l} h_1 = 2978.4 \text{ kJ/kg} \\ T_1 = 300^\circ\text{C} \end{array} \right. & \left\{ \begin{array}{l} s_1 = 6.4484 \text{ kJ/kg}\cdot\text{K} \\ \end{array} \right. \\ P_2 = 1.6 \text{ MPa} & \left\{ \begin{array}{l} h_2 = 2919.9 \text{ kJ/kg} \\ T_2 = 250^\circ\text{C} \end{array} \right. & \left\{ \begin{array}{l} s_2 = 6.6753 \text{ kJ/kg}\cdot\text{K} \\ \end{array} \right. \\ T_0 = 18^\circ\text{C} & \left\{ \begin{array}{l} h_0 = 75.54 \text{ kJ/kg} \\ x = 0 \end{array} \right. & \left\{ \begin{array}{l} s_0 = 0.2678 \text{ kJ/kg}\cdot\text{K} \\ \end{array} \right. \end{aligned}$$

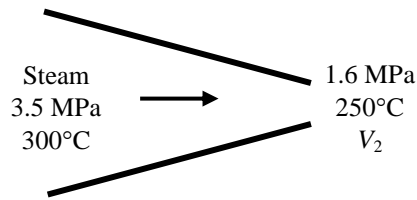

The exit velocity is determined from an energy balance on the nozzle

$$\begin{aligned} h_1 + \frac{V_1^2}{2} &= h_2 + \frac{V_2^2}{2} \\ 2978.4 \text{ kJ/kg} + \frac{(0 \text{ m/s})^2}{2} \left(\frac{1 \text{ kJ/kg}}{1000 \text{ m}^2/\text{s}^2} \right) &= 2919.9 \text{ kJ/kg} + \frac{V_2^2}{2} \left(\frac{1 \text{ kJ/kg}}{1000 \text{ m}^2/\text{s}^2} \right) \\ V_2 &= \mathbf{342.0 \text{ m/s}} \end{aligned}$$

(b) The rate of exergy destruction is the exergy decrease of the steam in the nozzle

$$\begin{aligned} \dot{X}_{\text{dest}} &= -\dot{m} \left[h_2 - h_1 + \frac{V_2^2 - V_1^2}{2} - T_0(s_2 - s_1) \right] \\ &= -(0.4 \text{ kg/s}) \left[(2919.9 - 2978.4) \text{ kJ/kg} + \frac{(342 \text{ m/s})^2 - 0}{2} \left(\frac{1 \text{ kJ/kg}}{1000 \text{ m}^2/\text{s}^2} \right) \right. \\ &\quad \left. - (291 \text{ K})(6.6753 - 6.4484) \text{ kJ/kg}\cdot\text{K} \right] \\ &= \mathbf{26.41 \text{ kW}} \end{aligned}$$

(c) The exergy of the refrigerant at the inlet is

$$\begin{aligned} \dot{X}_1 &= \dot{m} \left[h_1 - h_0 + \frac{V_1^2}{2} - T_0(s_1 - s_0) \right] \\ &= (0.4 \text{ kg/s}) [(2978.4 - 75.54) \text{ kJ/kg} + 0 - (291 \text{ K})(6.4484 - 0.2678) \text{ kJ/kg}\cdot\text{K}] \\ &= 441.72 \text{ kW} \end{aligned}$$

The second-law efficiency for a nozzle may be defined as the exergy recovered divided by the exergy expended:

$$\begin{aligned} \eta_{\text{II}} &= \frac{x_{\text{recovered}}}{x_{\text{expended}}} = \frac{V_2^2 / 2}{h_1 - h_2 - T_0(s_1 - s_2) + V_1^2 / 2} \\ &= \frac{\frac{(342 \text{ m/s})^2 - 0}{2} \left(\frac{1 \text{ kJ/kg}}{1000 \text{ m}^2/\text{s}^2} \right)}{(2978.4 - 2919.9) \text{ kJ/kg} - (291 \text{ K})(6.4484 - 6.6753) \text{ kJ/kg}\cdot\text{K} + 0} \\ &= 0.886 = \mathbf{88.6\%} \end{aligned}$$

Discussion Alternatively, the second-law efficiency for this device may be defined as the exergy output divided by the exergy input:

$$\eta_{\text{II}} = \frac{\dot{X}_2}{\dot{X}_1} = 1 - \frac{\dot{X}_{\text{dest}}}{\dot{X}_1} = 1 - \frac{26.41 \text{ kW}}{441.72 \text{ kW}} = 0.940 = 94.0\%$$

8-89 Steam is condensed in a closed system at a constant pressure from a saturated vapor to a saturated liquid by rejecting heat to a thermal energy reservoir. The second law efficiency is to be determined.

Assumptions 1 Kinetic and potential energy changes are negligible.

Analysis We take the steam as the system. This is a closed system since no mass enters or leaves. The energy balance for this stationary closed system can be expressed as

$$\underbrace{E_{\text{in}} - E_{\text{out}}}_{\text{Net energy transfer by heat, work, and mass}} = \underbrace{\Delta E_{\text{system}}}_{\text{Change in internal, kinetic, potential, etc. energies}}$$

$$W_{b,\text{in}} - Q_{\text{out}} = \Delta U = m(u_2 - u_1)$$

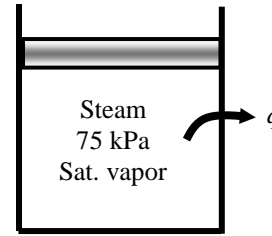

From the steam tables (Table A-5),

$$\left. \begin{array}{l} P_1 = 75 \text{ kPa} \\ \text{Sat. vapor} \end{array} \right\} \begin{array}{l} \nu_1 = \nu_g = 2.2172 \text{ m}^3/\text{kg} \\ u_1 = u_g = 2496.1 \text{ kJ/kg} \\ s_1 = s_g = 7.4558 \text{ kJ/kg} \cdot \text{K} \end{array}$$

$$\left. \begin{array}{l} P_2 = 75 \text{ kPa} \\ \text{Sat. liquid} \end{array} \right\} \begin{array}{l} \nu_2 = \nu_f = 0.001037 \text{ m}^3/\text{kg} \\ u_2 = u_f = 384.36 \text{ kJ/kg} \\ s_2 = s_f = 1.2132 \text{ kJ/kg} \cdot \text{K} \end{array}$$

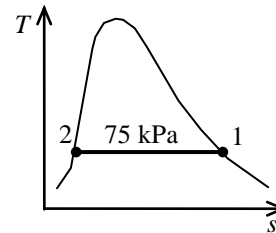

The boundary work during this process is

$$w_{b,\text{in}} = P(\nu_1 - \nu_2) = (75 \text{ kPa})(2.2172 - 0.001037) \text{ m}^3/\text{kg} \left(\frac{1 \text{ kJ}}{1 \text{ kPa} \cdot \text{m}^3} \right) = 166.2 \text{ kJ/kg}$$

The heat transfer is determined from the energy balance:

$$q_{\text{out}} = w_{b,\text{in}} - (u_2 - u_1) = 166.2 \text{ kJ/kg} - (384.36 - 2496.1) \text{ kJ/kg} = 2278 \text{ kJ/kg}$$

The exergy change between initial and final states is

$$\begin{aligned} \phi_1 - \phi_2 &= u_1 - u_2 + P_0(\nu_1 - \nu_2) - T_0(s_1 - s_2) - q_{\text{out}} \left(1 - \frac{T_0}{T_R} \right) \\ &= (2496.1 - 384.36) \text{ kJ/kg} + (100 \text{ kPa})(2.2172 - 0.001037) \text{ m}^3/\text{kg} \left(\frac{1 \text{ kJ}}{1 \text{ kPa} \cdot \text{m}^3} \right) \\ &\quad - (298 \text{ K})(7.4558 - 1.2132) \text{ kJ/kg} \cdot \text{K} - (2278 \text{ kJ/kg}) \left(1 - \frac{298 \text{ K}}{310 \text{ K}} \right) \\ &= 384.9 \text{ kJ/kg} \end{aligned}$$

The second law efficiency is then

$$\eta_{\text{II}} = \frac{w_{b,\text{in}}}{\Delta \phi} = \frac{166.2 \text{ kJ/kg}}{384.9 \text{ kJ/kg}} = 0.432 = \mathbf{43.2\%}$$

8-90 R-134a is vaporized in a closed system at a constant pressure from a saturated liquid to a saturated vapor by transferring heat from a reservoir at two pressures. The pressure that is more effective from a second-law point of view is to be determined.

Assumptions 1 Kinetic and potential energy changes are negligible.

Analysis We take the R-134a as the system. This is a closed system since no mass enters or leaves. The energy balance for this stationary closed system can be expressed as

$$\underbrace{E_{\text{in}} - E_{\text{out}}}_{\substack{\text{Net energy transfer} \\ \text{by heat, work, and mass}}} = \underbrace{\Delta E_{\text{system}}}_{\substack{\text{Change in internal, kinetic,} \\ \text{potential, etc. energies}}}$$

$$Q_{\text{in}} - W_{b,\text{out}} = \Delta U = m(u_2 - u_1)$$

$$Q_{\text{in}} = W_{b,\text{out}} + \Delta U$$

$$Q_{\text{in}} = \Delta H = m(h_2 - h_1)$$

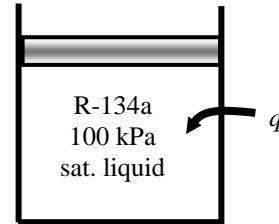

At 100 kPa:

From the R-134a tables (Table A-12),

$$u_{fg} @ 100 \text{ kPa} = 198.01 \text{ kJ/kg}$$

$$h_{fg} @ 100 \text{ kPa} = 217.19 \text{ kJ/kg}$$

$$s_{fg} @ 100 \text{ kPa} = 0.88008 \text{ kJ/kg} \cdot \text{K}$$

$$\nu_{fg} @ 100 \text{ kPa} = \nu_g - \nu_f = 0.19255 - 0.0007258 = 0.19182 \text{ m}^3/\text{kg}$$

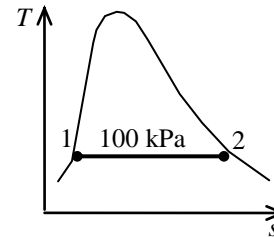

The boundary work during this process is

$$w_{b,\text{out}} = P(\nu_2 - \nu_1) = P\nu_{fg} = (100 \text{ kPa})(0.19182) \text{ m}^3/\text{kg} \left(\frac{1 \text{ kJ}}{1 \text{ kPa} \cdot \text{m}^3} \right) = 19.18 \text{ kJ/kg}$$

The useful work is determined from

$$w_u = w_{b,\text{out}} - w_{\text{surr}} = P(\nu_2 - \nu_1) - P_0(\nu_2 - \nu_1) = 0 \text{ kJ/kg}$$

since $P = P_0 = 100 \text{ kPa}$. The heat transfer from the energy balance is

$$q_{\text{in}} = h_{fg} = 217.19 \text{ kJ/kg}$$

The exergy change between initial and final states is

$$\begin{aligned} \phi_1 - \phi_2 &= u_1 - u_2 + P_0(\nu_1 - \nu_2) - T_0(s_1 - s_2) + q_{\text{in}} \left(1 - \frac{T_0}{T_R} \right) \\ &= -u_{fg} - P_0\nu_{fg} + T_0s_{fg} + q_{\text{in}} \left(1 - \frac{T_0}{T_R} \right) \\ &= -198.01 \text{ kJ/kg} - (100 \text{ kPa})(0.19182 \text{ m}^3/\text{kg}) \left(\frac{1 \text{ kJ}}{1 \text{ kPa} \cdot \text{m}^3} \right) + (298 \text{ K})(0.88008 \text{ kJ/kg} \cdot \text{K}) \\ &\quad + (217.19 \text{ kJ/kg}) \left(1 - \frac{298 \text{ K}}{279 \text{ K}} \right) \\ &= 30.28 \text{ kJ/kg} \end{aligned}$$

The second law efficiency is then

$$\eta_{\text{II}} = \frac{w_u}{\Delta\phi} = \frac{0 \text{ kJ/kg}}{30.28 \text{ kJ/kg}} = 0$$

At 180 kPa:

$$u_{fg} @ 180 \text{ kPa} = 188.20 \text{ kJ/kg}$$

$$h_{fg} @ 180 \text{ kPa} = 207.95 \text{ kJ/kg}$$

$$s_{fg} @ 180 \text{ kPa} = 0.79848 \text{ kJ/kg} \cdot \text{K}$$

$$\nu_{fg} @ 180 \text{ kPa} = \nu_g - \nu_f = 0.11049 - 0.0007485 = 0.10974 \text{ m}^3/\text{kg}$$

$$w_{b,\text{out}} = P(\nu_2 - \nu_1) = P\nu_{fg} = (180 \text{ kPa})(0.10974) \text{ m}^3/\text{kg} \left(\frac{1 \text{ kJ}}{1 \text{ kPa} \cdot \text{m}^3} \right) = 19.75 \text{ kJ/kg}$$

$$w_u = w_{b,\text{out}} - w_{\text{sunr}} = P(\nu_2 - \nu_1) - P_0(\nu_2 - \nu_1)$$

$$= (P - P_0)\nu_{fg} = (180 - 100) \text{ kPa}(0.10974) \text{ m}^3/\text{kg} \left(\frac{1 \text{ kJ}}{1 \text{ kPa} \cdot \text{m}^3} \right) = 8.779 \text{ kJ/kg}$$

$$q_{\text{in}} = h_{fg} = 207.95 \text{ kJ/kg}$$

$$\phi_1 - \phi_2 = u_1 - u_2 + P_0(\nu_1 - \nu_2) - T_0(s_1 - s_2) + q_{\text{in}} \left(1 - \frac{T_0}{T_R} \right)$$

$$= -u_{fg} - P_0\nu_{fg} + T_0s_{fg} + q_{\text{in}} \left(1 - \frac{T_0}{T_R} \right)$$

$$= -188.20 \text{ kJ/kg} - (100 \text{ kPa})(0.10974 \text{ m}^3/\text{kg}) \left(\frac{1 \text{ kJ}}{1 \text{ kPa} \cdot \text{m}^3} \right) + (298 \text{ K})(0.79848 \text{ kJ/kg} \cdot \text{K})$$

$$+ (207.95 \text{ kJ/kg}) \left(1 - \frac{298 \text{ K}}{279 \text{ K}} \right)$$

$$= 24.61 \text{ kJ/kg}$$

$$\eta_{\text{II}} = \frac{w_u}{\Delta\phi} = \frac{8.779 \text{ kJ/kg}}{24.61 \text{ kJ/kg}} = 0.3567 = \mathbf{35.7\%}$$

The process at 180 kPa is more effective from a work production standpoint.

8-91 Ethylene glycol is cooled by water in a heat exchanger. The rate of heat transfer and the rate of exergy destruction within the heat exchanger are to be determined.

Assumptions 1 Steady operating conditions exist. 2 The heat exchanger is well-insulated so that heat loss to the surroundings is negligible and thus heat transfer from the hot fluid is equal to the heat transfer to the cold fluid. 3 Changes in the kinetic and potential energies of fluid streams are negligible. 4 Fluid properties are constant. 5 The environment temperature is 20°C.

Properties The specific heats of water and ethylene glycol are given to be 4.18 and 2.56 kJ/kg·°C, respectively.

Analysis (a) We take the ethylene glycol tubes as the system, which is a control volume. The energy balance for this steady-flow system can be expressed in the rate form as

$$\underbrace{\dot{E}_{\text{in}} - \dot{E}_{\text{out}}}_{\text{Rate of net energy transfer by heat, work, and mass}} = \underbrace{\Delta \dot{E}_{\text{system}}}_{\text{Rate of change in internal, kinetic, potential, etc. energies}} \stackrel{\text{no}}{\neq} 0 \quad (\text{steady}) = 0$$

$$\dot{E}_{\text{in}} = \dot{E}_{\text{out}}$$

$$\dot{m}h_1 = \dot{Q}_{\text{out}} + \dot{m}h_2 \quad (\text{since } \Delta \text{ke} \cong \Delta \text{pe} \cong 0)$$

$$\dot{Q}_{\text{out}} = \dot{m}c_p(T_1 - T_2)$$

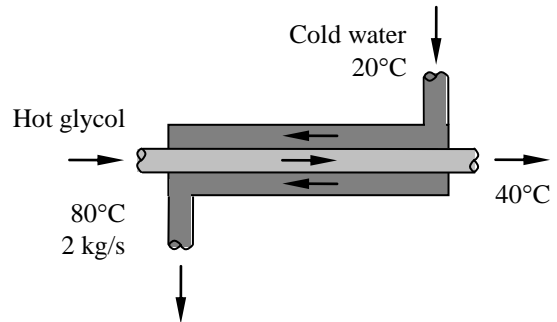

Then the rate of heat transfer becomes

$$\dot{Q}_{\text{out}} = [\dot{m}c_p(T_{\text{in}} - T_{\text{out}})]_{\text{glycol}} = (2 \text{ kg/s})(2.56 \text{ kJ/kg}\cdot\text{°C})(80\text{°C} - 40\text{°C}) = \mathbf{204.8 \text{ kW}}$$

The rate of heat transfer from water must be equal to the rate of heat transfer to the glycol. Then,

$$\dot{Q}_{\text{in}} = [\dot{m}c_p(T_{\text{out}} - T_{\text{in}})]_{\text{water}} \longrightarrow \dot{m}_{\text{water}} = \frac{\dot{Q}_{\text{in}}}{c_p(T_{\text{out}} - T_{\text{in}})} = \frac{204.8 \text{ kJ/s}}{(4.18 \text{ kJ/kg}\cdot\text{°C})(55 - 20)\text{°C}} = 1.4 \text{ kg/s}$$

(b) The rate of entropy generation within the heat exchanger is determined by applying the rate form of the entropy balance on the entire heat exchanger:

$$\underbrace{\dot{S}_{\text{in}} - \dot{S}_{\text{out}}}_{\text{Rate of net entropy transfer by heat and mass}} + \underbrace{\dot{S}_{\text{gen}}}_{\text{Rate of entropy generation}} = \underbrace{\Delta \dot{S}_{\text{system}}}_{\text{Rate of change of entropy}} \stackrel{\text{no}}{\neq} 0 \quad (\text{steady})$$

$$\dot{m}_1 s_1 + \dot{m}_3 s_3 - \dot{m}_2 s_2 - \dot{m}_4 s_4 + \dot{S}_{\text{gen}} = 0 \quad (\text{since } \dot{Q} = 0)$$

$$\dot{m}_{\text{glycol}} s_1 + \dot{m}_{\text{water}} s_3 - \dot{m}_{\text{glycol}} s_2 - \dot{m}_{\text{water}} s_4 + \dot{S}_{\text{gen}} = 0$$

$$\dot{S}_{\text{gen}} = \dot{m}_{\text{glycol}}(s_2 - s_1) + \dot{m}_{\text{water}}(s_4 - s_3)$$

Noting that both fluid streams are liquids (incompressible substances), the rate of entropy generation is determined to be

$$\dot{S}_{\text{gen}} = \dot{m}_{\text{glycol}} c_p \ln \frac{T_2}{T_1} + \dot{m}_{\text{water}} c_p \ln \frac{T_4}{T_3}$$

$$= (2 \text{ kg/s})(2.56 \text{ kJ/kg}\cdot\text{K}) \ln \frac{40 + 273}{80 + 273} + (1.4 \text{ kg/s})(4.18 \text{ kJ/kg}\cdot\text{K}) \ln \frac{55 + 273}{20 + 273} = 0.0446 \text{ kW/K}$$

The exergy destroyed during a process can be determined from an exergy balance or directly from its definition $\dot{X}_{\text{destroyed}} = T_0 \dot{S}_{\text{gen}}$,

$$\dot{X}_{\text{destroyed}} = T_0 \dot{S}_{\text{gen}} = (293 \text{ K})(0.0446 \text{ kW/K}) = \mathbf{13.1 \text{ kW}}$$

8-92 Oil is to be cooled by water in a thin-walled heat exchanger. The rate of heat transfer and the rate of exergy destruction within the heat exchanger are to be determined.

Assumptions 1 Steady operating conditions exist. 2 The heat exchanger is well-insulated so that heat loss to the surroundings is negligible and thus heat transfer from the hot fluid is equal to the heat transfer to the cold fluid. 3 Changes in the kinetic and potential energies of fluid streams are negligible. 4 Fluid properties are constant.

Properties The specific heats of water and oil are given to be 4.18 and 2.20 kJ/kg·°C, respectively.

Analysis We take the oil tubes as the system, which is a control volume. The energy balance for this steady-flow system can be expressed in the rate form as

$$\underbrace{\dot{E}_{\text{in}} - \dot{E}_{\text{out}}}_{\text{Rate of net energy transfer by heat, work, and mass}} = \underbrace{\Delta \dot{E}_{\text{system}}}_{\text{Rate of change in internal, kinetic, potential, etc. energies}} \stackrel{\approx 0 \text{ (steady)}}{=} 0$$

$$\dot{E}_{\text{in}} = \dot{E}_{\text{out}}$$

$$\dot{m}h_1 = \dot{Q}_{\text{out}} + \dot{m}h_2 \quad (\text{since } \Delta ke \cong \Delta pe \cong 0)$$

$$\dot{Q}_{\text{out}} = \dot{m}c_p(T_1 - T_2)$$

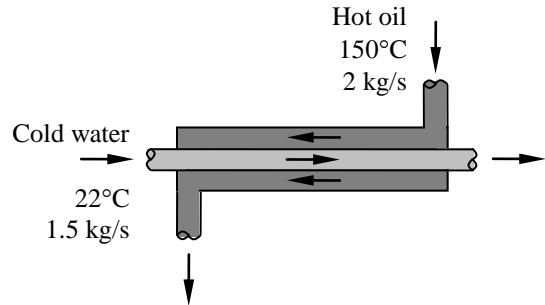

Then the rate of heat transfer from the oil becomes

$$\dot{Q}_{\text{out}} = [\dot{m}c_p(T_{\text{in}} - T_{\text{out}})]_{\text{oil}} = (2 \text{ kg/s})(2.2 \text{ kJ/kg}\cdot\text{°C})(150\text{°C} - 40\text{°C}) = \mathbf{484 \text{ kW}}$$

Noting that heat lost by the oil is gained by the water, the outlet temperature of water is determined from

$$\dot{Q} = [\dot{m}c_p(T_{\text{in}} - T_{\text{out}})]_{\text{water}} \longrightarrow T_{\text{out}} = T_{\text{in}} + \frac{\dot{Q}}{\dot{m}c_p} = 22\text{°C} - \frac{484 \text{ kW}}{(1.5 \text{ kg/s})(4.18 \text{ kJ/kg}\cdot\text{°C})} = 99.2\text{°C}$$

(b) The rate of entropy generation within the heat exchanger is determined by applying the rate form of the entropy balance on the entire heat exchanger:

$$\underbrace{\dot{S}_{\text{in}} - \dot{S}_{\text{out}}}_{\text{Rate of net entropy transfer by heat and mass}} + \underbrace{\dot{S}_{\text{gen}}}_{\text{Rate of entropy generation}} = \underbrace{\Delta \dot{S}_{\text{system}}}_{\text{Rate of change of entropy}} \stackrel{\approx 0 \text{ (steady)}}{=} 0$$

$$\dot{m}_1 s_1 + \dot{m}_3 s_3 - \dot{m}_2 s_2 - \dot{m}_4 s_4 + \dot{S}_{\text{gen}} = 0 \quad (\text{since } \dot{Q} = 0)$$

$$\dot{m}_{\text{oil}} s_1 + \dot{m}_{\text{water}} s_3 - \dot{m}_{\text{oil}} s_2 - \dot{m}_{\text{water}} s_4 + \dot{S}_{\text{gen}} = 0$$

$$\dot{S}_{\text{gen}} = \dot{m}_{\text{oil}}(s_2 - s_1) + \dot{m}_{\text{water}}(s_4 - s_3)$$

Noting that both fluid streams are liquids (incompressible substances), the rate of entropy generation is determined to be

$$\dot{S}_{\text{gen}} = \dot{m}_{\text{oil}} c_p \ln \frac{T_2}{T_1} + \dot{m}_{\text{water}} c_p \ln \frac{T_4}{T_3}$$

$$= (2 \text{ kg/s})(2.2 \text{ kJ/kg}\cdot\text{K}) \ln \frac{40 + 273}{150 + 273} + (1.5 \text{ kg/s})(4.18 \text{ kJ/kg}\cdot\text{K}) \ln \frac{99.2 + 273}{22 + 273} = 0.132 \text{ kW/K}$$

The exergy destroyed during a process can be determined from an exergy balance or directly from its definition $\dot{X}_{\text{destroyed}} = T_0 \dot{S}_{\text{gen}}$,

$$\dot{X}_{\text{destroyed}} = T_0 \dot{S}_{\text{gen}} = (295 \text{ K})(0.132 \text{ kW/K}) = \mathbf{38.9 \text{ kW}}$$

8-93 Hot exhaust gases leaving an internal combustion engine is to be used to obtain saturated steam in an adiabatic heat exchanger. The rate at which the steam is obtained, the rate of exergy destruction, and the second-law efficiency are to be determined.

Assumptions 1 Steady operating conditions exist. 2 Kinetic and potential energy changes are negligible. 3 Air properties are used for exhaust gases. 4 Pressure drops in the heat exchanger are negligible.

Properties The gas constant of air is $R = 0.287 \text{ kJ/kg}\cdot\text{K}$. The specific heat of air at the average temperature of exhaust gases (650 K) is $c_p = 1.063 \text{ kJ/kg}\cdot\text{K}$ (Table A-2).

Analysis (a) We denote the inlet and exit states of exhaust gases by (1) and (2) and that of the water by (3) and (4). The properties of water are (Table A-4)

$$\left. \begin{aligned} T_3 &= 20^\circ\text{C} \\ x_3 &= 0 \end{aligned} \right\} \begin{aligned} h_3 &= 83.91 \text{ kJ/kg} \\ s_3 &= 0.29649 \text{ kJ/kg}\cdot\text{K} \end{aligned}$$

$$\left. \begin{aligned} T_4 &= 200^\circ\text{C} \\ x_4 &= 1 \end{aligned} \right\} \begin{aligned} h_4 &= 2792.0 \text{ kJ/kg} \\ s_4 &= 6.4302 \text{ kJ/kg}\cdot\text{K} \end{aligned}$$

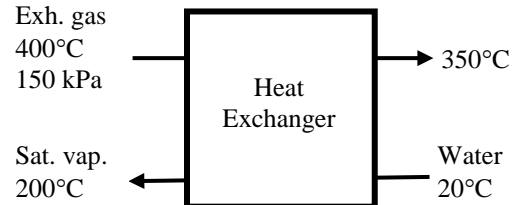

An energy balance on the heat exchanger gives

$$\begin{aligned} \dot{m}_a h_1 + \dot{m}_w h_3 &= \dot{m}_a h_2 + \dot{m}_w h_4 \\ \dot{m}_a c_p (T_1 - T_2) &= \dot{m}_w (h_4 - h_3) \\ (0.8 \text{ kg/s})(1.063 \text{ kJ/kg}\cdot^\circ\text{C})(400 - 350)^\circ\text{C} &= \dot{m}_w (2792.0 - 83.91) \text{ kJ/kg} \\ \dot{m}_w &= \mathbf{0.01570 \text{ kg/s}} \end{aligned}$$

(b) The specific exergy changes of each stream as it flows in the heat exchanger is

$$\Delta s_a = c_p \ln \frac{T_2}{T_1} = (0.8 \text{ kg/s})(1.063 \text{ kJ/kg}\cdot\text{K}) \ln \frac{(350 + 273) \text{ K}}{(400 + 273) \text{ K}} = -0.08206 \text{ kJ/kg}\cdot\text{K}$$

$$\begin{aligned} \Delta \psi_a &= c_p (T_2 - T_1) - T_0 \Delta s_a \\ &= (1.063 \text{ kJ/kg}\cdot^\circ\text{C})(350 - 400)^\circ\text{C} - (20 + 273 \text{ K})(-0.08206 \text{ kJ/kg}\cdot\text{K}) \\ &= -29.106 \text{ kJ/kg} \end{aligned}$$

$$\begin{aligned} \Delta \psi_w &= h_4 - h_3 - T_0 (s_4 - s_3) \\ &= (2792.0 - 83.91) \text{ kJ/kg} - (20 + 273 \text{ K})(6.4302 - 0.29649) \text{ kJ/kg}\cdot\text{K} \\ &= 910.913 \text{ kJ/kg} \end{aligned}$$

The exergy destruction is determined from an exergy balance on the heat exchanger to be

$$-\dot{X}_{\text{dest}} = \dot{m}_a \Delta \psi_a + \dot{m}_w \Delta \psi_w = (0.8 \text{ kg/s})(-29.106 \text{ kJ/kg}) + (0.01570 \text{ kg/s})(910.913 \text{ kJ/kg}) = -8.98 \text{ kW}$$

or

$$\dot{X}_{\text{dest}} = \mathbf{8.98 \text{ kW}}$$

(c) The second-law efficiency for a heat exchanger may be defined as the exergy increase of the cold fluid divided by the exergy decrease of the hot fluid. That is,

$$\eta_{\text{II}} = \frac{\dot{m}_w \Delta \psi_w}{-\dot{m}_a \Delta \psi_a} = \frac{(0.01570 \text{ kg/s})(910.913 \text{ kJ/kg})}{-(0.8 \text{ kg/s})(-29.106 \text{ kJ/kg})} = \mathbf{0.614}$$

8-94 Elevation, base area, and the depth of a crater lake are given. The maximum amount of electricity that can be generated by a hydroelectric power plant is to be determined.

Assumptions The evaporation of water from the lake is negligible.

Analysis The exergy or work potential of the water is the potential energy it possesses relative to the ground level,

$$\text{Exergy} = PE = mgh$$

Therefore,

$$\begin{aligned} \text{Exergy} = PE &= \int dPE = \int gz dm = \int gz(\rho A dz) \\ &= \rho Ag \int_{z_1}^{z_2} z dz = \rho Ag(z_2^2 - z_1^2)/2 \\ &= 0.5(1000 \text{ kg/m}^3)(2 \times 10^4 \text{ m}^2)(9.81 \text{ m/s}^2) \\ &\quad \times ((152 \text{ m})^2 - (140 \text{ m})^2) \left(\frac{1 \text{ h}}{3600 \text{ s}} \right) \left(\frac{1 \text{ kJ/kg}}{1000 \text{ m}^2/\text{s}^2} \right) \\ &= \mathbf{9.55 \times 10^4 \text{ kWh}} \end{aligned}$$

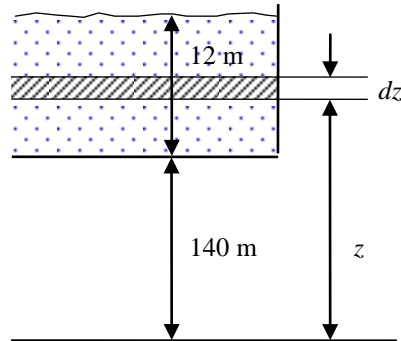

8-95 The inner and outer surfaces of a brick wall are maintained at specified temperatures. The rate of exergy destruction is to be determined.

Assumptions 1 Steady operating conditions exist since the surface temperatures of the wall remain constant at the specified values. **2** The environment temperature is given to be $T_0 = 0^\circ\text{C}$.

Analysis We take the wall to be the system, which is a closed system. Under steady conditions, the rate form of the entropy balance for the wall simplifies to

$$\begin{aligned} \underbrace{\dot{S}_{\text{in}} - \dot{S}_{\text{out}}}_{\text{Rate of net entropy transfer by heat and mass}} + \underbrace{\dot{S}_{\text{gen}}}_{\text{Rate of entropy generation}} &= \underbrace{\Delta \dot{S}_{\text{system}}}_{\text{Rate of change of entropy}} \stackrel{\text{Eq. 0}}{=} 0 \\ \frac{\dot{Q}_{\text{in}}}{T_{\text{b,in}}} - \frac{\dot{Q}_{\text{out}}}{T_{\text{b,out}}} + \dot{S}_{\text{gen,wall}} &= 0 \\ \frac{900 \text{ W}}{293 \text{ K}} - \frac{900 \text{ W}}{278 \text{ K}} + \dot{S}_{\text{gen,wall}} = 0 &\rightarrow \dot{S}_{\text{gen,wall}} = 0.166 \text{ W/K} \end{aligned}$$

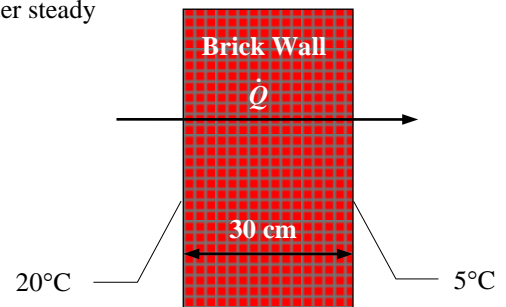

The exergy destroyed during a process can be determined from an exergy balance or directly from its definition $X_{\text{destroyed}} = T_0 S_{\text{gen}}$,

$$\dot{X}_{\text{destroyed}} = T_0 \dot{S}_{\text{gen}} = (273 \text{ K})(0.166 \text{ W/K}) = \mathbf{45.3 \text{ W}}$$

8-96 A 1000-W iron is left on the iron board with its base exposed to air. The rate of exergy destruction in steady operation is to be determined.

Assumptions Steady operating conditions exist.

Analysis The rate of total entropy generation during this process is determined by applying the entropy balance on an *extended system* that includes the iron and its immediate surroundings so that the boundary temperature of the extended system is 20°C at all times. It gives

$$\underbrace{\dot{S}_{\text{in}} - \dot{S}_{\text{out}}}_{\text{Rate of net entropy transfer by heat and mass}} + \underbrace{\dot{S}_{\text{gen}}}_{\text{Rate of entropy generation}} = \underbrace{\Delta\dot{S}_{\text{system}}}_{\text{Rate of change of entropy}} \stackrel{\neq 0}{=} 0$$

$$-\frac{\dot{Q}_{\text{out}}}{T_{\text{b,out}}} + \dot{S}_{\text{gen}} = 0$$

Therefore,

$$\dot{S}_{\text{gen}} = \frac{\dot{Q}_{\text{out}}}{T_{\text{b,out}}} = \frac{\dot{Q}}{T_0} = \frac{1000 \text{ W}}{293 \text{ K}} = 3.413 \text{ W/K}$$

The exergy destroyed during a process can be determined from an exergy balance or directly from its definition $\dot{X}_{\text{destroyed}} = T_0 \dot{S}_{\text{gen}}$,

$$\dot{X}_{\text{destroyed}} = T_0 \dot{S}_{\text{gen}} = (293 \text{ K})(3.413 \text{ W/K}) = \mathbf{1000 \text{ W}}$$

Discussion The rate of entropy generation within the iron can be determined by performing an entropy balance on the iron alone (it gives 2.21 W/K). Therefore, about one-third of the entropy generation and thus exergy destruction occurs within the iron. The rest occurs in the air surrounding the iron as the temperature drops from 150°C to 20°C without serving any useful purpose.

8-97 An electric resistance heater is immersed in water. The time it will take for the electric heater to raise the water temperature to a specified temperature, the minimum work input, and the exergy destroyed during this process are to be determined.

Assumptions 1 Water is an incompressible substance with constant specific heats. **2** The energy stored in the container itself and the heater is negligible. **3** Heat loss from the container is negligible. **4** The environment temperature is given to be $T_0 = 20^\circ\text{C}$.

Properties The specific heat of water at room temperature is $c = 4.18 \text{ kJ/kg}\cdot^\circ\text{C}$ (Table A-3).

Analysis Taking the water in the container as the system, which is a closed system, the energy balance can be expressed as

$$\underbrace{E_{\text{in}} - E_{\text{out}}}_{\substack{\text{Net energy transfer} \\ \text{by heat, work, and mass}}} = \underbrace{\Delta E_{\text{system}}}_{\substack{\text{Change in internal, kinetic,} \\ \text{potential, etc. energies}}}$$

$$W_{\text{e,in}} = (\Delta U)_{\text{water}}$$

$$\dot{W}_{\text{e,in}} \Delta t = mc(T_2 - T_1)_{\text{water}}$$

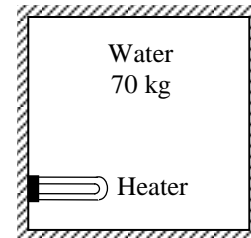

Substituting,

$$(1500 \text{ J/s})\Delta t = (70 \text{ kg})(4180 \text{ J/kg}\cdot^\circ\text{C})(80 - 20)^\circ\text{C}$$

Solving for Δt gives

$$\Delta t = 11,704 \text{ s} = 195 \text{ min} = \mathbf{3.25 \text{ h}}$$

Again we take the water in the tank to be the system. Noting that no heat or mass crosses the boundaries of this system and the energy and entropy contents of the heater are negligible, the entropy balance for it can be expressed as

$$\underbrace{S_{\text{in}} - S_{\text{out}}}_{\substack{\text{Net entropy transfer} \\ \text{by heat and mass}}} + \underbrace{S_{\text{gen}}}_{\substack{\text{Entropy} \\ \text{generation}}} = \underbrace{\Delta S_{\text{system}}}_{\substack{\text{Change} \\ \text{in entropy}}}$$

$$0 + S_{\text{gen}} = \Delta S_{\text{water}}$$

Therefore, the entropy generated during this process is

$$S_{\text{gen}} = \Delta S_{\text{water}} = mc \ln \frac{T_2}{T_1} = (70 \text{ kg})(4.18 \text{ kJ/kg}\cdot\text{K}) \ln \frac{353 \text{ K}}{293 \text{ K}} = 54.51 \text{ kJ/K}$$

The exergy destroyed during a process can be determined from an exergy balance or directly from its definition $X_{\text{destroyed}} = T_0 S_{\text{gen}}$,

$$X_{\text{destroyed}} = T_0 S_{\text{gen}} = (293 \text{ K})(54.51 \text{ kJ/K}) = \mathbf{15,971 \text{ kJ}}$$

The actual work input for this process is

$$W_{\text{act,in}} = \dot{W}_{\text{act,in}} \Delta t = (1.5 \text{ kJ/s})(11,704 \text{ s}) = 17,556 \text{ kJ}$$

Then the reversible (or minimum required) work input becomes

$$W_{\text{rev,in}} = W_{\text{act,in}} - X_{\text{destroyed}} = 17,556 - 15,971 = \mathbf{1585 \text{ kJ}}$$

8-98 Steam is accelerated in a nozzle. The actual and maximum outlet velocities are to be determined.

Assumptions **1** The nozzle operates steadily. **2** The changes in potential energies are negligible.

Properties The properties of steam at the inlet and the exit of the nozzle are (Tables A-4 through A-6)

$$\left. \begin{aligned} P_1 &= 300 \text{ kPa} \\ T_1 &= 150^\circ\text{C} \end{aligned} \right\} \begin{aligned} h_1 &= 2761.2 \text{ kJ/kg} \\ s_1 &= 7.0792 \text{ kJ/kg} \cdot \text{K} \end{aligned}$$

$$\left. \begin{aligned} P_2 &= 150 \text{ kPa} \\ x_2 &= 1 \text{ (sat. vapor)} \end{aligned} \right\} \begin{aligned} h_2 &= 2693.1 \text{ kJ/kg} \\ s_2 &= 7.2231 \text{ kJ/kg} \cdot \text{K} \end{aligned}$$

Analysis We take the nozzle to be the system, which is a control volume. The energy balance for this steady-flow system can be expressed in the rate form as

$$\underbrace{\dot{E}_{\text{in}} - \dot{E}_{\text{out}}}_{\text{Rate of net energy transfer by heat, work, and mass}} = \underbrace{\Delta \dot{E}_{\text{system}}^{\cancel{0}}}_{\text{Rate of change in internal, kinetic, potential, etc. energies (steady)}} = 0$$

$$\dot{E}_{\text{in}} = \dot{E}_{\text{out}}$$

$$\dot{m}(h_1 + V_1^2/2) = \dot{m}(h_2 + V_2^2/2)$$

$$\frac{V_2^2 - V_1^2}{2} = h_1 - h_2 = \Delta \text{ke}_{\text{actual}}$$

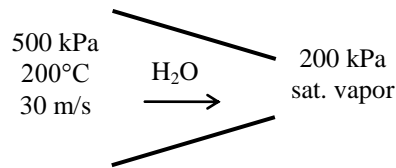

Substituting,

$$\Delta \text{ke}_{\text{actual}} = h_1 - h_2 = 2761.2 - 2693.1 = 68.1 \text{ kJ/kg}$$

The actual velocity at the exit is then

$$\frac{V_2^2 - V_1^2}{2} = \Delta \text{ke}_{\text{actual}}$$

$$V_2 = \sqrt{V_1^2 + 2\Delta \text{ke}_{\text{actual}}} = \sqrt{(45 \text{ m/s})^2 + 2(68.1 \text{ kJ/kg}) \left(\frac{1000 \text{ m}^2/\text{s}^2}{1 \text{ kJ/kg}} \right)} = \mathbf{371.8 \text{ m/s}}$$

The maximum kinetic energy change is determined from

$$\Delta \text{ke}_{\text{max}} = h_1 - h_2 - T_0(s_1 - s_2) = 68.1 - (298)(7.0792 - 7.2231) = 111.0 \text{ kJ/kg}$$

The maximum velocity at the exit is then

$$\frac{V_{2,\text{max}}^2 - V_1^2}{2} = \Delta \text{ke}_{\text{max}}$$

or

$$V_{2,\text{max}} = \sqrt{V_1^2 + 2\Delta \text{ke}_{\text{max}}} = \sqrt{(45 \text{ m/s})^2 + 2(111.0 \text{ kJ/kg}) \left(\frac{1000 \text{ m}^2/\text{s}^2}{1 \text{ kJ/kg}} \right)} = \mathbf{473.3 \text{ m/s}}$$

8-99E Steam is expanded in a two-stage turbine. Six percent of the inlet steam is bled for feedwater heating. The isentropic efficiencies for the two stages of the turbine are given. The second-law efficiency of the turbine is to be determined.

Assumptions 1 This is a steady-flow process since there is no change with time. **2** The turbine is well-insulated, and there is no heat transfer from the turbine.

Analysis There is one inlet and two exits. We take the turbine as the system, which is a control volume since mass crosses the boundary. The energy balance for this steady-flow system can be expressed in the rate form as

$$\underbrace{\dot{E}_{\text{in}} - \dot{E}_{\text{out}}}_{\text{Rate of net energy transfer by heat, work, and mass}} = \underbrace{\dot{\Delta E}_{\text{system}}}_{\text{Rate of change in internal, kinetic, potential, etc. energies}} \stackrel{\text{no (steady)}}{=} 0$$

$$\dot{E}_{\text{in}} = \dot{E}_{\text{out}}$$

$$\dot{m}_1 h_1 = \dot{m}_2 h_2 + \dot{m}_3 h_3 + \dot{W}_{\text{out}}$$

$$\dot{W}_{\text{out}} = \dot{m}_1 h_1 - \dot{m}_2 h_2 - \dot{m}_3 h_3$$

$$w_{\text{out}} = h_1 - 0.06h_2 - 0.94h_3$$

$$w_{\text{out}} = (h_1 - h_2) + 0.94(h_2 - h_3)$$

The isentropic and actual enthalpies at three states are determined using steam tables as follows:

$$\left. \begin{array}{l} P_1 = 500 \text{ psia} \\ T_1 = 600^\circ\text{F} \end{array} \right\} \begin{array}{l} h_1 = 1298.6 \text{ Btu/lbm} \\ s_1 = 1.5590 \text{ Btu/lbm}\cdot\text{R} \end{array}$$

$$\left. \begin{array}{l} P_2 = 100 \text{ psia} \\ s_{2s} = s_1 = 1.5590 \text{ Btu/lbm}\cdot\text{R} \end{array} \right\} \begin{array}{l} x_{2s} = 0.9609 \\ h_{2s} = 1152.7 \text{ Btu/lbm} \end{array}$$

$$\eta_{T,1} = \frac{h_1 - h_2}{h_1 - h_{2s}} \longrightarrow h_2 = h_1 - \eta_{T,1}(h_1 - h_{2s}) = 1298.6 - (0.97)(1298.6 - 1152.7) = 1157.1 \text{ kJ/kg}$$

$$\left. \begin{array}{l} P_2 = 100 \text{ psia} \\ h_2 = 1157.1 \text{ Btu/lbm} \end{array} \right\} \begin{array}{l} x_2 = 0.9658 \\ s_2 = 1.5646 \text{ Btu/lbm}\cdot\text{R} \end{array}$$

$$\left. \begin{array}{l} P_3 = 5 \text{ psia} \\ s_3 = s_2 = 1.5646 \text{ kJ/kg}\cdot\text{K} \end{array} \right\} \begin{array}{l} x_{3s} = 0.8265 \\ h_{3s} = 957.09 \text{ Btu/lbm} \end{array}$$

$$\eta_{T,2} = \frac{h_2 - h_3}{h_2 - h_{3s}} \longrightarrow h_3 = h_2 - \eta_{T,2}(h_2 - h_{3s}) = 1157.1 - (0.95)(1157.1 - 957.09) = 967.09 \text{ kJ/kg}$$

$$\left. \begin{array}{l} P_3 = 5 \text{ psia} \\ h_3 = 967.09 \text{ Btu/lbm} \end{array} \right\} \begin{array}{l} x_3 = 0.8364 \\ s_3 = 1.5807 \text{ Btu/lbm}\cdot\text{R} \end{array}$$

Substituting into the energy balance per unit mass flow at the inlet of the turbine, we obtain

$$\begin{aligned} w_{\text{out}} &= (h_1 - h_2) + 0.94(h_2 - h_3) \\ &= (1298.6 - 1157.1) + 0.94(1157.1 - 967.09) = 320.1 \text{ Btu/lbm} \end{aligned}$$

The reversible work output per unit mass flow at the turbine inlet is

$$\begin{aligned} w_{\text{rev}} &= h_1 - h_2 - T_0(s_1 - s_2) + 0.94[h_2 - h_3 - T_0(s_2 - s_3)] \\ &= 1298.6 - 1157.1 - (537)(1.5590 - 1.5646) + 0.94[(1157.1 - 967.09) - (537)(1.5646 - 1.5807)] \\ &= 331.2 \text{ Btu/lbm} \end{aligned}$$

The second law efficiency is then

$$\eta_{\text{II}} = \frac{w_{\text{out}}}{w_{\text{rev}}} = \frac{320.1 \text{ Btu/lbm}}{331.2 \text{ Btu/lbm}} = 0.966 = \mathbf{96.6\%}$$

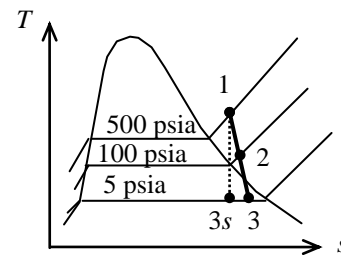
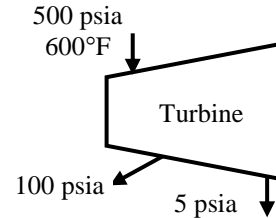

8-100 A throttle valve is placed in the steam line supplying the turbine inlet in order to control an isentropic steam turbine. The second-law efficiency of this system when the valve is partially open to when it is fully open is to be compared.

Assumptions 1 This is a steady-flow process since there is no change with time. **2** The turbine is well-insulated, and there is no heat transfer from the turbine.

Analysis

Valve is fully open:

The properties of steam at various states are

$$\left. \begin{array}{l} P_0 = 100 \text{ kPa} \\ T_1 = 25^\circ\text{C} \end{array} \right\} \begin{array}{l} h_0 \cong h_f @ 25^\circ\text{C} = 104.83 \text{ kJ/kg} \\ s_0 \cong s_f @ 25^\circ\text{C} = 0.3672 \text{ kJ/kg} \cdot \text{K} \end{array}$$

$$\left. \begin{array}{l} P_1 = P_2 = 6 \text{ MPa} \\ T_1 = T_2 = 600^\circ\text{C} \end{array} \right\} \begin{array}{l} h_1 = h_2 = 3658.8 \text{ kJ/kg} \\ s_1 = s_2 = 7.1693 \text{ kJ/kg} \cdot \text{K} \end{array}$$

$$\left. \begin{array}{l} P_3 = 40 \text{ kPa} \\ s_2 = s_1 \end{array} \right\} \begin{array}{l} x_3 = 0.9248 \\ h_3 = 2461.7 \text{ kJ/kg} \end{array}$$

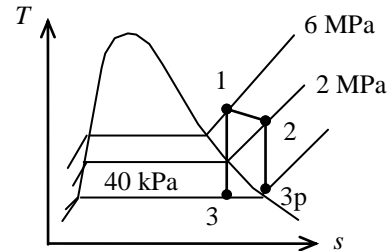

The stream exergy at the turbine inlet is

$$\psi_1 = h_1 - h_0 - T_0(s_1 - s_0) = 3658.8 - 104.83 - (298)(7.1693 - 0.3672) = \mathbf{1527 \text{ kJ/kg}}$$

The second law efficiency of the entire system is then

$$\eta_{II} = \frac{w_{\text{out}}}{w_{\text{rev}}} = \frac{h_1 - h_3}{h_1 - h_3 - T_0(s_1 - s_3)} = \frac{h_1 - h_3}{h_1 - h_3} = \mathbf{1.0}$$

since $s_1 = s_3$ for this system.

Valve is partly open:

$$\left. \begin{array}{l} P_2 = 2 \text{ MPa} \\ h_2 = h_1 = 3658.8 \text{ kJ/kg} \end{array} \right\} s_2 = 7.6674 \text{ kJ/kg} \cdot \text{K} \quad (\text{from EES})$$

$$\left. \begin{array}{l} P_3 = 40 \text{ kPa} \\ s_3 = s_2 \end{array} \right\} h_3 = 2635.5 \text{ kJ/kg} \quad (\text{from EES})$$

$$\psi_2 = h_2 - h_0 - T_0(s_2 - s_0) = 3658.8 - 104.83 - (298)(7.6674 - 0.3672) = \mathbf{1378 \text{ kJ/kg}}$$

$$\eta_{II} = \frac{w_{\text{out}}}{w_{\text{rev}}} = \frac{h_2 - h_3}{h_2 - h_3 - T_0(s_2 - s_3)} = \frac{3658.8 - 2635.5}{3658.8 - 2635.5 - (298)(7.6674 - 7.6674)} = \mathbf{1.0}$$

8-101 Two rigid tanks that contain water at different states are connected by a valve. The valve is opened and steam flows from tank A to tank B until the pressure in tank A drops to a specified value. Tank B loses heat to the surroundings. The final temperature in each tank and the work potential wasted during this process are to be determined.

Assumptions 1 Tank A is insulated and thus heat transfer is negligible. **2** The water that remains in tank A undergoes a reversible adiabatic process. **3** The thermal energy stored in the tanks themselves is negligible. **4** The system is stationary and thus kinetic and potential energy changes are negligible. **5** There are no work interactions.

Analysis (a) The steam in tank A undergoes a reversible, adiabatic process, and thus $s_2 = s_1$. From the steam tables (Tables A-4 through A-6),

Tank A :

$$P_1 = 400 \text{ kPa} \left\{ \begin{array}{l} v_{1,A} = v_f + x_1 v_{fg} = 0.001084 + (0.8)(0.46242 - 0.001084) = 0.37015 \text{ m}^3/\text{kg} \\ u_{1,A} = u_f + x_1 u_{fg} = 604.22 + (0.8)(1948.9) = 2163.3 \text{ kJ/kg} \\ s_{1,A} = s_f + x_1 s_{fg} = 1.7765 + (0.8)(5.1191) = 5.8717 \text{ kJ/kg} \cdot \text{K} \end{array} \right.$$

$$T_{2,A} = T_{sat@300\text{kPa}} = \mathbf{133.52^\circ\text{C}}$$

$$P_2 = 300 \text{ kPa} \left\{ \begin{array}{l} x_{2,A} = \frac{s_{2,A} - s_f}{s_{fg}} = \frac{5.8717 - 1.6717}{5.3200} = 0.7895 \\ v_{2,A} = v_f + x_{2,A} v_{fg} = 0.001073 + (0.7895)(0.60582 - 0.001073) = 0.47850 \text{ m}^3/\text{kg} \\ u_{2,A} = u_f + x_{2,A} u_{fg} = 561.11 + (0.7895)(1982.1 \text{ kJ/kg}) = 2125.9 \text{ kJ/kg} \end{array} \right.$$

Tank B :

$$P_1 = 200 \text{ kPa} \left\{ \begin{array}{l} v_{1,B} = 1.1989 \text{ m}^3/\text{kg} \\ u_{1,B} = 2731.4 \text{ kJ/kg} \\ s_{1,B} = 7.7100 \text{ kJ/kg} \cdot \text{K} \end{array} \right.$$

The initial and the final masses in tank A are

$$m_{1,A} = \frac{v_A}{v_{1,A}} = \frac{0.2 \text{ m}^3}{0.37015 \text{ m}^3/\text{kg}} = 0.5403 \text{ kg}$$

and

$$m_{2,A} = \frac{v_A}{v_{2,A}} = \frac{0.2 \text{ m}^3}{0.479 \text{ m}^3/\text{kg}} = 0.4180 \text{ kg}$$

Thus, $0.540 - 0.418 = 0.122 \text{ kg}$ of mass flows into tank B. Then,

$$m_{2,B} = m_{1,B} - 0.122 = 3 + 0.122 = 3.122 \text{ kg}$$

The final specific volume of steam in tank B is determined from

$$v_{2,B} = \frac{v_B}{m_{2,B}} = \frac{(m_1 v_1)_B}{m_{2,B}} = \frac{(3 \text{ kg})(1.1989 \text{ m}^3/\text{kg})}{3.122 \text{ m}^3} = 1.152 \text{ m}^3/\text{kg}$$

We take the entire contents of both tanks as the system, which is a closed system. The energy balance for this stationary closed system can be expressed as

$$\underbrace{E_{in} - E_{out}}_{\text{Net energy transfer by heat, work, and mass}} = \underbrace{\Delta E_{system}}_{\text{Change in internal, kinetic, potential, etc. energies}}$$

$$-Q_{out} = \Delta U = (\Delta U)_A + (\Delta U)_B \quad (\text{since } W = KE = PE = 0)$$

$$-Q_{out} = (m_2 u_2 - m_1 u_1)_A + (m_2 u_2 - m_1 u_1)_B$$

Substituting,

$$-900 = \{(0.418)(2125.9) - (0.5403)(2163.3)\} + \{(3.122)u_{2,B} - (3)(2731.4)\}$$

$$u_{2,B} = 2425.9 \text{ kJ/kg}$$

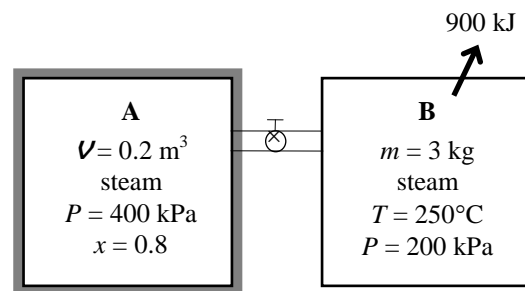

Thus,

$$\left. \begin{aligned} v_{2,B} &= 1.152 \text{ m}^3/\text{kg} \\ u_{2,B} &= 2425.9 \text{ kJ/kg} \end{aligned} \right\} \begin{aligned} T_{2,B} &= \mathbf{110.1^\circ\text{C}} \\ s_{2,B} &= 6.9772 \text{ kJ/kg}\cdot\text{K} \end{aligned}$$

(b) The total entropy generation during this process is determined by applying the entropy balance on an *extended system* that includes both tanks and their immediate surroundings so that the boundary temperature of the extended system is the temperature of the surroundings at all times. It gives

$$\underbrace{S_{\text{in}} - S_{\text{out}}}_{\substack{\text{Net entropy transfer} \\ \text{by heat and mass}}} + \underbrace{S_{\text{gen}}}_{\substack{\text{Entropy} \\ \text{generation}}} = \underbrace{\Delta S_{\text{system}}}_{\substack{\text{Change} \\ \text{in entropy}}}$$

$$-\frac{Q_{\text{out}}}{T_{\text{b,surr}}} + S_{\text{gen}} = \Delta S_A + \Delta S_B$$

Rearranging and substituting, the total entropy generated during this process is determined to be

$$\begin{aligned} S_{\text{gen}} &= \Delta S_A + \Delta S_B + \frac{Q_{\text{out}}}{T_{\text{b,surr}}} = (m_2 s_2 - m_1 s_1)_A + (m_2 s_2 - m_1 s_1)_B + \frac{Q_{\text{out}}}{T_{\text{b,surr}}} \\ &= \{(0.418)(5.8717) - (0.5403)(5.8717)\} + \{(3.122)(6.9772) - (3)(7.7100)\} + \frac{900 \text{ kJ}}{273 \text{ K}} \\ &= 1.234 \text{ kJ/K} \end{aligned}$$

The work potential wasted is equivalent to the exergy destroyed during a process, which can be determined from an exergy balance or directly from its definition $X_{\text{destroyed}} = T_0 S_{\text{gen}}$,

$$X_{\text{destroyed}} = T_0 S_{\text{gen}} = (273 \text{ K})(1.234 \text{ kJ/K}) = \mathbf{337 \text{ kJ}}$$

8-102E A cylinder initially filled with helium gas at a specified state is compressed polytropically to a specified temperature and pressure. The actual work consumed and the minimum useful work input needed are to be determined.

Assumptions 1 Helium is an ideal gas with constant specific heats. 2 The cylinder is stationary and thus the kinetic and potential energy changes are negligible. 3 The thermal energy stored in the cylinder itself is negligible. 4 The compression or expansion process is quasi-equilibrium. 5 The environment temperature is 70°F.

Properties The gas constant of helium is $R = 2.6805 \text{ psia}\cdot\text{ft}^3/\text{lbm}\cdot\text{R} = 0.4961 \text{ Btu}/\text{lbm}\cdot\text{R}$ (Table A-1E). The specific heats of helium are $c_v = 0.753$ and $c_p = 1.25 \text{ Btu}/\text{lbm}\cdot\text{R}$ (Table A-2E).

Analysis (a) Helium at specified conditions can be treated as an ideal gas. The mass of helium is

$$m = \frac{P_1 V_1}{RT_1} = \frac{(40 \text{ psia})(8 \text{ ft}^3)}{(2.6805 \text{ psia}\cdot\text{ft}^3/\text{lbm}\cdot\text{R})(530 \text{ R})} = 0.2252 \text{ lbm}$$

The exponent n and the boundary work for this polytropic process are determined to be

$$\frac{P_1 V_1}{T_1} = \frac{P_2 V_2}{T_2} \longrightarrow V_2 = \frac{T_2}{T_1} \frac{P_1}{P_2} V_1 = \frac{(780 \text{ R})(40 \text{ psia})}{(530 \text{ R})(140 \text{ psia})} (8 \text{ ft}^3) = 3.364 \text{ ft}^3$$

$$P_2 V_2^n = P_1 V_1^n \longrightarrow \left(\frac{P_2}{P_1}\right) = \left(\frac{V_1}{V_2}\right)^n \longrightarrow \left(\frac{140}{40}\right) = \left(\frac{8}{3.364}\right)^n \longrightarrow n = 1.446$$

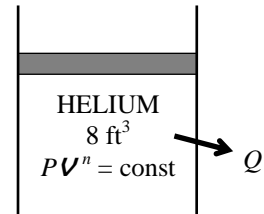

Then the boundary work for this polytropic process can be determined from

$$\begin{aligned} W_{b,\text{in}} &= -\int_1^2 P dV = -\frac{P_2 V_2 - P_1 V_1}{1-n} = -\frac{mR(T_2 - T_1)}{1-n} \\ &= -\frac{(0.2252 \text{ lbm})(0.4961 \text{ Btu}/\text{lbm}\cdot\text{R})(780 - 530)\text{R}}{1-1.446} = 62.62 \text{ Btu} \end{aligned}$$

Also,

$$W_{\text{sur},\text{in}} = -P_0 (V_2 - V_1) = -(14.7 \text{ psia})(3.364 - 8)\text{ft}^3 \left(\frac{1 \text{ Btu}}{5.4039 \text{ psia}\cdot\text{ft}^3}\right) = 12.61 \text{ Btu}$$

Thus,

$$W_{u,\text{in}} = W_{b,\text{in}} - W_{\text{sur},\text{in}} = 62.62 - 12.61 = \mathbf{50.0 \text{ Btu}}$$

(b) We take the helium in the cylinder as the system, which is a closed system. Taking the direction of heat transfer to be from the cylinder, the energy balance for this stationary closed system can be expressed as

$$\begin{aligned} \underbrace{E_{\text{in}} - E_{\text{out}}}_{\text{Net energy transfer by heat, work, and mass}} &= \underbrace{\Delta E_{\text{system}}}_{\text{Change in internal, kinetic, potential, etc. energies}} \\ -Q_{\text{out}} + W_{b,\text{in}} &= \Delta U = m(u_2 - u_1) \\ -Q_{\text{out}} &= m(u_2 - u_1) - W_{b,\text{in}} \\ Q_{\text{out}} &= W_{b,\text{in}} - mc_v(T_2 - T_1) \end{aligned}$$

Substituting,

$$Q_{\text{out}} = 62.62 \text{ Btu} - (0.2252 \text{ lbm})(0.753 \text{ Btu}/\text{lbm}\cdot\text{R})(780 - 530)\text{R} = 20.69 \text{ Btu}$$

The total entropy generation during this process is determined by applying the entropy balance on an *extended system* that includes the cylinder and its immediate surroundings so that the boundary temperature of the extended system is the temperature of the surroundings at all times. It gives

$$\begin{aligned} \underbrace{S_{\text{in}} - S_{\text{out}}}_{\text{Net entropy transfer by heat and mass}} + \underbrace{S_{\text{gen}}}_{\text{Entropy generation}} &= \underbrace{\Delta S_{\text{system}}}_{\text{Change in entropy}} \\ -\frac{Q_{\text{out}}}{T_{b,\text{sur}}} + S_{\text{gen}} &= \Delta S_{\text{sys}} \end{aligned}$$

where the entropy change of helium is

$$\begin{aligned}\Delta S_{\text{sys}} &= \Delta S_{\text{helium}} = m \left(c_{p,\text{avg}} \ln \frac{T_2}{T_1} - R \ln \frac{P_2}{P_1} \right) \\ &= (0.2252 \text{ lbm}) \left[(1.25 \text{ Btu/lbm} \cdot \text{R}) \ln \frac{780 \text{ R}}{530 \text{ R}} - (0.4961 \text{ Btu/lbm} \cdot \text{R}) \ln \frac{140 \text{ psia}}{40 \text{ psia}} \right] \\ &= -0.03201 \text{ Btu/R}\end{aligned}$$

Rearranging and substituting, the total entropy generated during this process is determined to be

$$S_{\text{gen}} = \Delta S_{\text{helium}} + \frac{Q_{\text{out}}}{T_0} = (-0.03201 \text{ Btu/R}) + \frac{20.69 \text{ Btu}}{530 \text{ R}} = 0.007022 \text{ Btu/R}$$

The work potential wasted is equivalent to the exergy destroyed during a process, which can be determined from an exergy balance or directly from its definition $X_{\text{destroyed}} = T_0 S_{\text{gen}}$,

$$X_{\text{destroyed}} = T_0 S_{\text{gen}} = (530 \text{ R})(0.007022 \text{ Btu/R}) = 3.722 \text{ Btu}$$

The minimum work with which this process could be accomplished is the reversible work input, $W_{\text{rev,in}}$ which can be determined directly from

$$W_{\text{rev,in}} = W_{\text{u,in}} - X_{\text{destroyed}} = 50.0 - 3.722 = \mathbf{46.3 \text{ Btu}}$$

Discussion The reversible work input, which represents the minimum work input $W_{\text{rev,in}}$ in this case can be determined from the exergy balance by setting the exergy destruction term equal to zero,

$$\underbrace{X_{\text{in}} - X_{\text{out}}}_{\substack{\text{Net exergy transfer} \\ \text{by heat, work, and mass}}} - \underbrace{X_{\text{destroyed}}}_{\substack{\text{Exergy} \\ \text{destruction}}} \stackrel{\approx 0 \text{ (reversible)}}{=} \underbrace{\Delta X_{\text{system}}}_{\substack{\text{Change} \\ \text{in exergy}}} \rightarrow W_{\text{rev,in}} = X_2 - X_1$$

Substituting the closed system exergy relation, the reversible work input during this process is determined to be

$$\begin{aligned}W_{\text{rev}} &= (U_2 - U_1) - T_0(S_2 - S_1) + P_0(\mathcal{V}_2 - \mathcal{V}_1) \\ &= (0.2252 \text{ lbm})(0.753 \text{ Btu/lbm} \cdot \text{R})(320 - 70)^\circ\text{F} - (530 \text{ R})(-0.03201 \text{ Btu/R}) \\ &\quad + (14.7 \text{ psia})(3.364 - 8) \text{ ft}^3 [\text{Btu}/5.4039 \text{ psia} \cdot \text{ft}^3] \\ &= \mathbf{46.7 \text{ Btu}}\end{aligned}$$

The slight difference is due to round-off error.

8-103 Steam expands in a two-stage adiabatic turbine from a specified state to specified pressure. Some steam is extracted at the end of the first stage. The wasted power potential is to be determined.

Assumptions 1 This is a steady-flow process since there is no change with time. **2** Kinetic and potential energy changes are negligible. **3** The turbine is adiabatic and thus heat transfer is negligible. **4** The environment temperature is given to be $T_0 = 25^\circ\text{C}$.

Analysis The wasted power potential is equivalent to the rate of exergy destruction during a process, which can be determined from an exergy balance or directly from its definition $X_{\text{destroyed}} = T_0 \dot{S}_{\text{gen}}$.

The total rate of entropy generation during this process is determined by taking the entire turbine, which is a control volume, as the system and applying the entropy balance. Noting that this is a steady-flow process and there is no heat transfer,

$$\underbrace{\dot{S}_{\text{in}} - \dot{S}_{\text{out}}}_{\text{Rate of net entropy transfer by heat and mass}} + \underbrace{\dot{S}_{\text{gen}}}_{\text{Rate of entropy generation}} = \underbrace{\Delta\dot{S}_{\text{system}}}_{\text{Rate of change of entropy}} \stackrel{\neq 0}{=} 0$$

$$\dot{m}_1 s_1 - \dot{m}_2 s_2 - \dot{m}_3 s_3 + \dot{S}_{\text{gen}} = 0$$

$$\dot{m}_1 s_1 - 0.1\dot{m}_1 s_2 - 0.9\dot{m}_1 s_3 + \dot{S}_{\text{gen}} = 0 \rightarrow \dot{S}_{\text{gen}} = \dot{m}_1 [0.9s_3 + 0.1s_2 - s_1]$$

and $X_{\text{destroyed}} = T_0 \dot{S}_{\text{gen}} = T_0 \dot{m}_1 [0.9s_3 + 0.1s_2 - s_1]$

From the steam tables (Tables A-4 through 6)

$$\left. \begin{array}{l} P_1 = 7 \text{ MPa} \\ T_1 = 400^\circ\text{C} \end{array} \right\} \begin{array}{l} h_1 = 3159.2 \text{ kJ/kg} \\ s_1 = 6.4502 \text{ kJ/kg}\cdot\text{K} \end{array}$$

$$\left. \begin{array}{l} P_2 = 1.8 \text{ MPa} \\ s_{2s} = s_1 \end{array} \right\} h_{2s} = 2831.3 \text{ kJ/kg}$$

and

$$\eta_T = \frac{h_1 - h_2}{h_1 - h_{2s}} \rightarrow h_2 = h_1 - \eta_T (h_1 - h_{2s})$$

$$= 3159.2 - 0.88(3159.2 - 2831.3)$$

$$= 2870.6 \text{ kJ/kg}$$

$$\left. \begin{array}{l} P_2 = 1.8 \text{ MPa} \\ h_2 = 2870.6 \text{ kJ/kg} \end{array} \right\} s_2 = 6.5290 \text{ kJ/kg}\cdot\text{K}$$

$$\left. \begin{array}{l} P_3 = 10 \text{ kPa} \\ s_{3s} = s_1 \end{array} \right\} \begin{array}{l} x_{3s} = \frac{s_{3s} - s_f}{s_{fg}} = \frac{6.64502 - 0.6492}{7.4996} = 0.7735 \\ h_{3s} = h_f + x_{3s} h_{fg} = 191.81 + 0.7735 \times 2392.1 = 2042.1 \text{ kJ/kg} \end{array}$$

and $\eta_T = \frac{h_1 - h_3}{h_1 - h_{3s}} \rightarrow h_3 = h_1 - \eta_T (h_1 - h_{3s})$

$$= 3159.2 - 0.88(3159.2 - 2042.1)$$

$$= 2176.1 \text{ kJ/kg}$$

$$\left. \begin{array}{l} P_3 = 10 \text{ kPa} \\ h_3 = 2176.1 \text{ kJ/kg} \end{array} \right\} \begin{array}{l} x_3 = \frac{h_3 - h_f}{h_{fg}} = \frac{2176.1 - 191.81}{2392.1} = 0.8295 \\ s_3 = s_f + x_3 s_{fg} = 0.6492 + 0.8295 \times 7.4996 = 6.8705 \text{ kJ/kg}\cdot\text{K} \end{array}$$

Substituting, the wasted work potential is determined to be

$$\dot{X}_{\text{destroyed}} = T_0 \dot{S}_{\text{gen}} = (298 \text{ K})(15 \text{ kg/s})(0.9 \times 6.8705 + 0.1 \times 6.5290 - 6.4502) \text{ kJ/kg} = \mathbf{1726 \text{ kW}}$$

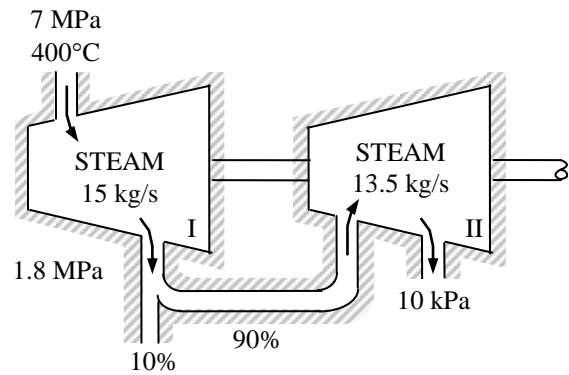

8-104 Steam expands in a two-stage adiabatic turbine from a specified state to another specified state. Steam is reheated between the stages. For a given power output, the reversible power output and the rate of exergy destruction are to be determined.

Assumptions 1 This is a steady-flow process since there is no change with time. **2** Kinetic and potential energy changes are negligible. **3** The turbine is adiabatic and thus heat transfer is negligible. **4** The environment temperature is given to be $T_0 = 25^\circ\text{C}$.

Properties From the steam tables (Tables A-4 through 6)

$$\left. \begin{array}{l} P_1 = 8 \text{ MPa} \\ T_1 = 500^\circ\text{C} \end{array} \right\} \begin{array}{l} h_1 = 3399.5 \text{ kJ/kg} \\ s_1 = 6.7266 \text{ kJ/kg}\cdot\text{K} \end{array}$$

$$\left. \begin{array}{l} P_2 = 2 \text{ MPa} \\ T_2 = 350^\circ\text{C} \end{array} \right\} \begin{array}{l} h_2 = 3137.7 \text{ kJ/kg} \\ s_2 = 6.9583 \text{ kJ/kg}\cdot\text{K} \end{array}$$

$$\left. \begin{array}{l} P_3 = 2 \text{ MPa} \\ T_3 = 500^\circ\text{C} \end{array} \right\} \begin{array}{l} h_3 = 3468.3 \text{ kJ/kg} \\ s_3 = 7.4337 \text{ kJ/kg}\cdot\text{K} \end{array}$$

$$\left. \begin{array}{l} P_4 = 30 \text{ kPa} \\ x_4 = 0.97 \end{array} \right\} \begin{array}{l} h_4 = h_f + x_4 h_{fg} = 289.27 + 0.97 \times 2335.3 = 2554.5 \text{ kJ/kg} \\ s_4 = s_f + x_4 s_{fg} = 0.9441 + 0.97 \times 6.8234 = 7.5628 \text{ kJ/kg}\cdot\text{K} \end{array}$$

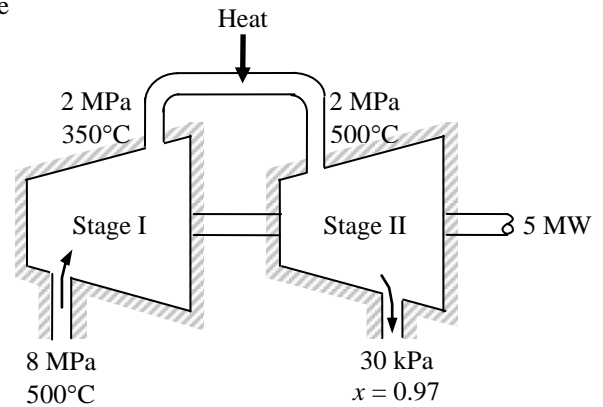

Analysis We take the entire turbine, excluding the reheat section, as the system, which is a control volume. The energy balance for this steady-flow system can be expressed in the rate form as

$$\underbrace{\dot{E}_{\text{in}} - \dot{E}_{\text{out}}}_{\text{Rate of net energy transfer by heat, work, and mass}} = \underbrace{\Delta \dot{E}_{\text{system}}^{\text{0 (steady)}}}_{\text{Rate of change in internal, kinetic, potential, etc. energies}} = 0$$

$$\dot{E}_{\text{in}} = \dot{E}_{\text{out}}$$

$$\dot{m}h_1 + \dot{m}h_3 = \dot{m}h_2 + \dot{m}h_4 + \dot{W}_{\text{out}}$$

$$\dot{W}_{\text{out}} = \dot{m}[(h_1 - h_2) + (h_3 - h_4)]$$

Substituting, the mass flow rate of the steam is determined from the steady-flow energy equation applied to the actual process,

$$\dot{m} = \frac{\dot{W}_{\text{out}}}{h_1 - h_2 + h_3 - h_4} = \frac{5000 \text{ kJ/s}}{(3399.5 - 3137.7 + 3468.3 - 2554.5) \text{ kJ/kg}} = 4.253 \text{ kg/s}$$

The reversible (or maximum) power output is determined from the rate form of the exergy balance applied on the turbine and setting the exergy destruction term equal to zero,

$$\underbrace{\dot{X}_{\text{in}} - \dot{X}_{\text{out}}}_{\text{Rate of net exergy transfer by heat, work, and mass}} - \underbrace{\dot{X}_{\text{destroyed}}^{\text{0 (reversible)}}}_{\text{Rate of exergy destruction}} = \underbrace{\Delta \dot{X}_{\text{system}}^{\text{0 (steady)}}}_{\text{Rate of change of exergy}} = 0$$

$$\dot{X}_{\text{in}} = \dot{X}_{\text{out}}$$

$$\dot{m}\psi_1 + \dot{m}\psi_3 = \dot{m}\psi_2 + \dot{m}\psi_4 + \dot{W}_{\text{rev,out}}$$

$$\dot{W}_{\text{rev,out}} = \dot{m}(\psi_1 - \psi_2) + \dot{m}(\psi_3 - \psi_4)$$

$$= \dot{m}[(h_1 - h_2) + T_0(s_2 - s_1) - \Delta ke^{\text{0}} - \Delta pe^{\text{0}}]$$

$$+ \dot{m}[(h_3 - h_4) + T_0(s_4 - s_3) - \Delta ke^{\text{0}} - \Delta pe^{\text{0}}]$$

Then the reversible power becomes

$$\begin{aligned} \dot{W}_{\text{rev,out}} &= \dot{m}[h_1 - h_2 + h_3 - h_4 + T_0(s_2 - s_1 + s_4 - s_3)] \\ &= (4.253 \text{ kg/s})[(3399.5 - 3137.7 + 3468.3 - 2554.5) \text{ kJ/kg} \\ &\quad + (298 \text{ K})(6.9583 - 6.7266 + 7.5628 - 7.4337) \text{ kJ/kg}\cdot\text{K}] \\ &= \mathbf{5457 \text{ kW}} \end{aligned}$$

Then the rate of exergy destruction is determined from its definition,

$$\dot{X}_{\text{destroyed}} = \dot{W}_{\text{rev,out}} - \dot{W}_{\text{out}} = 5457 - 5000 = \mathbf{457 \text{ kW}}$$

8-105 A well-insulated room is heated by a steam radiator, and the warm air is distributed by a fan. The average temperature in the room after 30 min, the entropy changes of steam and air, and the exergy destruction during this process are to be determined.

Assumptions 1 Air is an ideal gas with constant specific heats at room temperature. 2 The kinetic and potential energy changes are negligible. 3 The air pressure in the room remains constant and thus the air expands as it is heated, and some warm air escapes. 4 The environment temperature is given to be $T_0 = 10^\circ\text{C}$.

Properties The gas constant of air is $R = 0.287 \text{ kPa}\cdot\text{m}^3/\text{kg}\cdot\text{K}$ (Table A-1). Also, $c_p = 1.005 \text{ kJ/kg}\cdot\text{K}$ for air at room temperature (Table A-2).

Analysis We first take the radiator as the system. This is a closed system since no mass enters or leaves. The energy balance for this closed system can be expressed as

$$\underbrace{E_{\text{in}} - E_{\text{out}}}_{\text{Net energy transfer by heat, work, and mass}} = \underbrace{\Delta E_{\text{system}}}_{\text{Change in internal, kinetic, potential, etc. energies}}$$

$$-Q_{\text{out}} = \Delta U = m(u_2 - u_1) \quad (\text{since } W = \text{KE} = \text{PE} = 0)$$

$$Q_{\text{out}} = m(u_1 - u_2)$$

Using data from the steam tables (Tables A-4 through A-6), some properties are determined to be

$$\left. \begin{array}{l} P_1 = 200 \text{ kPa} \\ T_1 = 200^\circ\text{C} \end{array} \right\} \begin{array}{l} \nu_1 = 1.0805 \text{ m}^3/\text{kg} \\ u_1 = 2654.6 \text{ kJ/kg} \\ s_1 = 7.5081 \text{ kJ/kg}\cdot\text{K} \end{array}$$

$$\left. \begin{array}{l} P_2 = 100 \text{ kPa} \\ (\nu_2 = \nu_1) \end{array} \right\} \begin{array}{l} \nu_f = 0.001043, \quad \nu_g = 1.6941 \text{ m}^3/\text{kg} \\ u_f = 417.40, \quad u_{fg} = 2088.2 \text{ kJ/kg} \\ s_f = 1.3028 \text{ kJ/kg}\cdot\text{K}, \quad s_{fg} = 6.0562 \text{ kJ/kg}\cdot\text{K} \end{array}$$

$$x_2 = \frac{\nu_2 - \nu_f}{\nu_{fg}} = \frac{1.0805 - 0.001043}{1.6941 - 0.001043} = 0.6376$$

$$u_2 = u_f + x_2 u_{fg} = 417.40 + 0.6376 \times 2088.2 = 1748.7 \text{ kJ/kg}$$

$$s_2 = s_f + x_2 s_{fg} = 1.3028 + 0.6376 \times 6.0562 = 5.1639 \text{ kJ/kg}\cdot\text{K}$$

$$m = \frac{\nu_1}{\nu_1} = \frac{0.015 \text{ m}^3}{1.0805 \text{ m}^3/\text{kg}} = 0.01388 \text{ kg}$$

Substituting,

$$Q_{\text{out}} = (0.01388 \text{ kg})(2654.6 - 1748.7) \text{ kJ/kg} = 12.58 \text{ kJ}$$

The volume and the mass of the air in the room are $\nu = 4 \times 4 \times 5 = 80 \text{ m}^3$

and

$$m_{\text{air}} = \frac{P_1 \nu_1}{RT_1} = \frac{(100 \text{ kPa})(80 \text{ m}^3)}{(0.2870 \text{ kPa}\cdot\text{m}^3/\text{kg}\cdot\text{K})(283 \text{ K})} = 98.5 \text{ kg}$$

The amount of fan work done in 24 min is

$$W_{\text{fan, in}} = \dot{W}_{\text{fan, in}} \Delta t = (0.150 \text{ kJ/s})(24 \times 60 \text{ s}) = 216 \text{ kJ}$$

We now take the air in the room as the system. The energy balance for this closed system is expressed as

$$E_{\text{in}} - E_{\text{out}} = \Delta E_{\text{system}}$$

$$Q_{\text{in}} + W_{\text{fan, in}} - W_{\text{b, out}} = \Delta U$$

$$Q_{\text{in}} + W_{\text{fan, in}} = \Delta H \cong mc_p(T_2 - T_1)$$

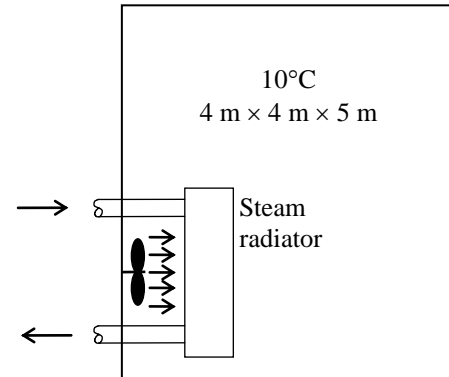

since the boundary work and ΔU combine into ΔH for a constant pressure expansion or compression process. It can also be expressed as

$$(\dot{Q}_{\text{in}} + \dot{W}_{\text{fan,in}})\Delta t = mc_{p,\text{avg}}(T_2 - T_1)$$

Substituting,

$$(12.58 \text{ kJ}) + (216 \text{ kJ}) = (98.5 \text{ kg})(1.005 \text{ kJ/kg}\cdot\text{C})(T_2 - 10)^\circ\text{C}$$

which yields

$$T_2 = \mathbf{12.3^\circ\text{C}}$$

Therefore, the air temperature in the room rises from 10°C to 12.3°C in 24 minutes.

(b) The entropy change of the steam is

$$\Delta S_{\text{steam}} = m(s_2 - s_1) = (0.01388 \text{ kg})(5.1639 - 7.5081) \text{ kJ/kg}\cdot\text{K} = \mathbf{-0.0325 \text{ kJ/K}}$$

(c) Noting that air expands at constant pressure, the entropy change of the air in the room is

$$\Delta S_{\text{air}} = mc_p \ln \frac{T_2}{T_1} - mR \ln \frac{P_2}{P_1} \stackrel{\phi=0}{=} (98.5 \text{ kg})(1.005 \text{ kJ/kg}\cdot\text{K}) \ln \frac{285.3 \text{ K}}{283 \text{ K}} = \mathbf{0.8012 \text{ kJ/K}}$$

(d) We take the contents of the room (including the steam radiator) as our system, which is a closed system. Noting that no heat or mass crosses the boundaries of this system, the entropy balance for it can be expressed as

$$\underbrace{S_{\text{in}} - S_{\text{out}}}_{\substack{\text{Net entropy transfer} \\ \text{by heat and mass}}} + \underbrace{S_{\text{gen}}}_{\substack{\text{Entropy} \\ \text{generation}}} = \underbrace{\Delta S_{\text{system}}}_{\substack{\text{Change} \\ \text{in entropy}}} \\ 0 + S_{\text{gen}} = \Delta S_{\text{steam}} + \Delta S_{\text{air}}$$

Substituting, the entropy generated during this process is determined to be

$$S_{\text{gen}} = \Delta S_{\text{steam}} + \Delta S_{\text{air}} = -0.0325 + 0.8012 = 0.7687 \text{ kJ/K}$$

The exergy destroyed during a process can be determined from an exergy balance or directly from its definition $X_{\text{destroyed}} = T_0 S_{\text{gen}}$,

$$X_{\text{destroyed}} = T_0 S_{\text{gen}} = (283 \text{ K})(0.7687 \text{ kJ/K}) = \mathbf{218 \text{ kJ}}$$

Alternative Solution In the solution above, we assumed the air pressure in the room to remain constant. This is an extreme case, and it is commonly used in practice since it gives higher results for heat loads, and thus allows the designer to be conservative results. The other extreme is to assume the house to be airtight, and thus the volume of the air in the house to remain constant as the air is heated. There is no expansion in this case and thus boundary work, and c_v is used in energy change relation instead of c_p . It gives the following results:

$$T_2 = 13.2^\circ\text{C}$$

$$\Delta S_{\text{steam}} = m(s_2 - s_1) = (0.01388 \text{ kg})(5.1639 - 7.5081) \text{ kJ/kg}\cdot\text{K} = -0.0325 \text{ kJ/K}$$

$$\Delta S_{\text{air}} = mc_v \ln \frac{T_2}{T_1} + mR \ln \frac{v_2}{v_1} \stackrel{\phi=0}{=} (98.5 \text{ kg})(0.718 \text{ kJ/kg}\cdot\text{K}) \ln \frac{286.2 \text{ K}}{283 \text{ K}} = 0.7952 \text{ kJ/K}$$

$$S_{\text{gen}} = \Delta S_{\text{steam}} + \Delta S_{\text{air}} = -0.0325 + 0.7952 = 0.7627 \text{ kJ/K}$$

and

$$X_{\text{destroyed}} = T_0 S_{\text{gen}} = (283 \text{ K})(0.7627 \text{ kJ/K}) = 216 \text{ kJ}$$

The actual value in practice will be between these two limits.

8-106 An insulated cylinder is divided into two parts. One side of the cylinder contains N_2 gas and the other side contains He gas at different states. The final equilibrium temperature in the cylinder and the wasted work potential are to be determined for the cases of piston being fixed and moving freely.

Assumptions 1 Both N_2 and He are ideal gases with constant specific heats. **2** The energy stored in the container itself is negligible. **3** The cylinder is well-insulated and thus heat transfer is negligible.

Properties The gas constants and the specific heats are $R = 0.2968 \text{ kPa}\cdot\text{m}^3/\text{kg}\cdot\text{K}$, $c_p = 1.039 \text{ kJ/kg}\cdot^\circ\text{C}$, and $c_v = 0.743 \text{ kJ/kg}\cdot^\circ\text{C}$ for N_2 , and $R = 2.0769 \text{ kPa}\cdot\text{m}^3/\text{kg}\cdot\text{K}$, $c_p = 5.1926 \text{ kJ/kg}\cdot^\circ\text{C}$, and $c_v = 3.1156 \text{ kJ/kg}\cdot^\circ\text{C}$ for He (Tables A-1 and A-2).

Analysis The mass of each gas in the cylinder is

$$m_{N_2} = \left(\frac{P_1 V_1}{RT_1} \right)_{N_2} = \frac{(500 \text{ kPa})(1 \text{ m}^3)}{(0.2968 \text{ kPa}\cdot\text{m}^3/\text{kg}\cdot\text{K})(353 \text{ K})} = 4.772 \text{ kg}$$

$$m_{He} = \left(\frac{P_1 V_1}{RT_1} \right)_{He} = \frac{(500 \text{ kPa})(1 \text{ m}^3)}{(2.0769 \text{ kPa}\cdot\text{m}^3/\text{kg}\cdot\text{K})(298 \text{ K})} = 0.8079 \text{ kg}$$

N_2	He
1 m^3	1 m^3
500 kPa	500 kPa
80°C	25°C

Taking the entire contents of the cylinder as our system, the 1st law relation can be written as

$$\underbrace{E_{in} - E_{out}}_{\substack{\text{Net energy transfer} \\ \text{by heat, work, and mass}}} = \underbrace{\Delta E_{system}}_{\substack{\text{Change in internal, kinetic,} \\ \text{potential, etc. energies}}}$$

$$0 = \Delta U = (\Delta U)_{N_2} + (\Delta U)_{He}$$

$$0 = [mc_v(T_2 - T_1)]_{N_2} + [mc_v(T_2 - T_1)]_{He}$$

Substituting,

$$(4.772 \text{ kg})(0.743 \text{ kJ/kg}\cdot^\circ\text{C})(T_f - 80)^\circ\text{C} + (0.8079 \text{ kg})(3.1156 \text{ kJ/kg}\cdot^\circ\text{C})(T_f - 25)^\circ\text{C} = 0$$

It gives

$$T_f = 57.2^\circ\text{C}$$

where T_f is the final equilibrium temperature in the cylinder.

The answer would be the **same** if the piston were not free to move since it would effect only pressure, and not the specific heats.

(b) We take the entire cylinder as our system, which is a closed system. Noting that the cylinder is well-insulated and thus there is no heat transfer, the entropy balance for this closed system can be expressed as

$$\underbrace{S_{in} - S_{out}}_{\substack{\text{Net entropy transfer} \\ \text{by heat and mass}}} + \underbrace{S_{gen}}_{\substack{\text{Entropy} \\ \text{generation}}} = \underbrace{\Delta S_{system}}_{\substack{\text{Change} \\ \text{in entropy}}}$$

$$0 + S_{gen} = \Delta S_{N_2} + \Delta S_{He}$$

But first we determine the final pressure in the cylinder:

$$N_{total} = N_{N_2} + N_{He} = \left(\frac{m}{M} \right)_{N_2} + \left(\frac{m}{M} \right)_{He} = \frac{4.772 \text{ kg}}{28 \text{ kg/kmol}} + \frac{0.8079 \text{ kg}}{4 \text{ kg/kmol}} = 0.3724 \text{ kmol}$$

$$P_2 = \frac{N_{total} R_u T}{V_{total}} = \frac{(0.3724 \text{ kmol})(8.314 \text{ kPa}\cdot\text{m}^3/\text{kmol}\cdot\text{K})(330.2 \text{ K})}{2 \text{ m}^3} = 511.1 \text{ kPa}$$

Then,

$$\Delta S_{N_2} = m \left(c_p \ln \frac{T_2}{T_1} - R \ln \frac{P_2}{P_1} \right)_{N_2}$$

$$= (4.772 \text{ kg}) \left[(1.039 \text{ kJ/kg}\cdot\text{K}) \ln \frac{330.2 \text{ K}}{353 \text{ K}} - (0.2968 \text{ kJ/kg}\cdot\text{K}) \ln \frac{511.1 \text{ kPa}}{500 \text{ kPa}} \right] = -0.3628 \text{ kJ/K}$$

$$\begin{aligned}\Delta S_{\text{He}} &= m \left(c_p \ln \frac{T_2}{T_1} - R \ln \frac{P_2}{P_1} \right)_{\text{He}} \\ &= (0.8079 \text{ kg}) \left[(5.1926 \text{ kJ/kg} \cdot \text{K}) \ln \frac{330.2 \text{ K}}{298 \text{ K}} - (2.0769 \text{ kJ/kg} \cdot \text{K}) \ln \frac{511.1 \text{ kPa}}{500 \text{ kPa}} \right] = 0.3931 \text{ kJ/K} \\ S_{\text{gen}} &= \Delta S_{\text{N}_2} + \Delta S_{\text{He}} = -0.3628 + 0.3931 = 0.0303 \text{ kJ/K}\end{aligned}$$

The wasted work potential is equivalent to the exergy destroyed during a process, and it can be determined from an exergy balance or directly from its definition $X_{\text{destroyed}} = T_0 S_{\text{gen}}$,

$$X_{\text{destroyed}} = T_0 S_{\text{gen}} = (298 \text{ K})(0.0303 \text{ kJ/K}) = \mathbf{9.03 \text{ kJ}}$$

If the piston were not free to move, we would still have $T_2 = 330.2 \text{ K}$ but the volume of each gas would remain constant in this case:

$$\begin{aligned}\Delta S_{\text{N}_2} &= m \left(c_v \ln \frac{T_2}{T_1} - R \ln \frac{v_2^{\phi_0}}{v_1} \right)_{\text{N}_2} = (4.772 \text{ kg})(0.743 \text{ kJ/kg} \cdot \text{K}) \ln \frac{330.2 \text{ K}}{353 \text{ K}} = -0.2371 \text{ kJ/K} \\ \Delta S_{\text{He}} &= m \left(c_v \ln \frac{T_2}{T_1} - R \ln \frac{v_2^{\phi_0}}{v_1} \right)_{\text{He}} = (0.8079 \text{ kg})(3.1156 \text{ kJ/kg} \cdot \text{K}) \ln \frac{330.2 \text{ K}}{298 \text{ K}} = 0.258 \text{ kJ/K} \\ S_{\text{gen}} &= \Delta S_{\text{N}_2} + \Delta S_{\text{He}} = -0.2371 + 0.258 = 0.02089 \text{ kJ/K}\end{aligned}$$

and

$$X_{\text{destroyed}} = T_0 S_{\text{gen}} = (298 \text{ K})(0.02089 \text{ kJ/K}) = \mathbf{6.23 \text{ kJ}}$$

8-107 An insulated cylinder is divided into two parts. One side of the cylinder contains N_2 gas and the other side contains He gas at different states. The final equilibrium temperature in the cylinder and the wasted work potential are to be determined for the cases of piston being fixed and moving freely.

Assumptions 1 Both N_2 and He are ideal gases with constant specific heats. **2** The energy stored in the container itself, except the piston, is negligible. **3** The cylinder is well-insulated and thus heat transfer is negligible. **4** Initially, the piston is at the average temperature of the two gases.

Properties The gas constants and the specific heats are $R = 0.2968 \text{ kPa}\cdot\text{m}^3/\text{kg}\cdot\text{K}$, $c_p = 1.039 \text{ kJ/kg}\cdot^\circ\text{C}$, and $c_v = 0.743 \text{ kJ/kg}\cdot^\circ\text{C}$ for N_2 , and $R = 2.0769 \text{ kPa}\cdot\text{m}^3/\text{kg}\cdot\text{K}$, $c_p = 5.1926 \text{ kJ/kg}\cdot^\circ\text{C}$, and $c_v = 3.1156 \text{ kJ/kg}\cdot^\circ\text{C}$ for He (Tables A-1 and A-2). The specific heat of copper piston is $c = 0.386 \text{ kJ/kg}\cdot^\circ\text{C}$ (Table A-3).

Analysis The mass of each gas in the cylinder is

$$m_{N_2} = \left(\frac{P_1 V_1}{RT_1} \right)_{N_2} = \frac{(500 \text{ kPa})(1 \text{ m}^3)}{(0.2968 \text{ kPa}\cdot\text{m}^3/\text{kg}\cdot\text{K})(353 \text{ K})} = 4.772 \text{ kg}$$

$$m_{He} = \left(\frac{P_1 V_1}{RT_1} \right)_{He} = \frac{(500 \text{ kPa})(1 \text{ m}^3)}{(2.0769 \text{ kPa}\cdot\text{m}^3/\text{kg}\cdot\text{K})(353 \text{ K})} = 0.8079 \text{ kg}$$

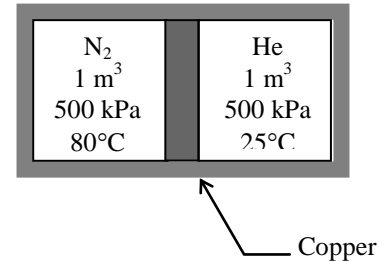

Taking the entire contents of the cylinder as our system, the first-law relation can be written as

$$\underbrace{E_{in} - E_{out}}_{\substack{\text{Net energy transfer} \\ \text{by heat, work, and mass}}} = \underbrace{\Delta E_{system}}_{\substack{\text{Change in internal, kinetic,} \\ \text{potential, etc. energies}}}$$

$$0 = \Delta U = (\Delta U)_{N_2} + (\Delta U)_{He} + (\Delta U)_{Cu}$$

$$0 = [mc_v(T_2 - T_1)]_{N_2} + [mc_v(T_2 - T_1)]_{He} + [mc(T_2 - T_1)]_{Cu}$$

where

$$T_{1, Cu} = (80 + 25) / 2 = 52.5^\circ\text{C}$$

Substituting,

$$(4.772 \text{ kg})(0.743 \text{ kJ/kg}\cdot^\circ\text{C})(T_f - 80)^\circ\text{C} + (0.8079 \text{ kg})(3.1156 \text{ kJ/kg}\cdot^\circ\text{C})(T_f - 25)^\circ\text{C} \\ + (5.0 \text{ kg})(0.386 \text{ kJ/kg}\cdot^\circ\text{C})(T_f - 52.5)^\circ\text{C} = 0$$

It gives

$$T_f = 56.0^\circ\text{C}$$

where T_f is the final equilibrium temperature in the cylinder.

The answer would be the **same** if the piston were not free to move since it would effect only pressure, and not the specific heats.

(b) We take the entire cylinder as our system, which is a closed system. Noting that the cylinder is well-insulated and thus there is no heat transfer, the entropy balance for this closed system can be expressed as

$$\underbrace{S_{in} - S_{out}}_{\substack{\text{Net entropy transfer} \\ \text{by heat and mass}}} + \underbrace{S_{gen}}_{\substack{\text{Entropy} \\ \text{generation}}} = \underbrace{\Delta S_{system}}_{\substack{\text{Change} \\ \text{in entropy}}}$$

$$0 + S_{gen} = \Delta S_{N_2} + \Delta S_{He} + \Delta S_{piston}$$

But first we determine the final pressure in the cylinder:

$$N_{total} = N_{N_2} + N_{He} = \left(\frac{m}{M} \right)_{N_2} + \left(\frac{m}{M} \right)_{He} = \frac{4.772 \text{ kg}}{28 \text{ kg/kmol}} + \frac{0.8079 \text{ kg}}{4 \text{ kg/kmol}} = 0.3724 \text{ kmol}$$

$$P_2 = \frac{N_{total} R_u T}{V_{total}} = \frac{(0.3724 \text{ kmol})(8.314 \text{ kPa}\cdot\text{m}^3/\text{kmol}\cdot\text{K})(329 \text{ K})}{2 \text{ m}^3} = 509.4 \text{ kPa}$$

Then,

$$\begin{aligned}\Delta S_{N_2} &= m \left(c_p \ln \frac{T_2}{T_1} - R \ln \frac{P_2}{P_1} \right)_{N_2} \\ &= (4.772 \text{ kg}) \left[(1.039 \text{ kJ/kg} \cdot \text{K}) \ln \frac{329 \text{ K}}{353 \text{ K}} - (0.2968 \text{ kJ/kg} \cdot \text{K}) \ln \frac{509.4 \text{ kPa}}{500 \text{ kPa}} \right] = -0.3749 \text{ kJ/K} \\ \Delta S_{He} &= m \left(c_p \ln \frac{T_2}{T_1} - R \ln \frac{P_2}{P_1} \right)_{He} \\ &= (0.8079 \text{ kg}) \left[(5.1926 \text{ kJ/kg} \cdot \text{K}) \ln \frac{329 \text{ K}}{353 \text{ K}} - (2.0769 \text{ kJ/kg} \cdot \text{K}) \ln \frac{509.4 \text{ kPa}}{500 \text{ kPa}} \right] = 0.3845 \text{ kJ/K} \\ \Delta S_{\text{piston}} &= \left(mc \ln \frac{T_2}{T_1} \right)_{\text{piston}} = (5 \text{ kg})(0.386 \text{ kJ/kg} \cdot \text{K}) \ln \frac{329 \text{ K}}{325.5 \text{ K}} = 0.021 \text{ kJ/K} \\ S_{\text{gen}} &= \Delta S_{N_2} + \Delta S_{He} + \Delta S_{\text{piston}} = -0.3749 + 0.3845 + 0.021 = 0.03047 \text{ kJ/K}\end{aligned}$$

The wasted work potential is equivalent to the exergy destroyed during a process, and it can be determined from an exergy balance or directly from its definition $X_{\text{destroyed}} = T_0 S_{\text{gen}}$,

$$X_{\text{destroyed}} = T_0 S_{\text{gen}} = (298 \text{ K})(0.03047 \text{ kJ/K}) = \mathbf{9.08 \text{ kJ}}$$

If the piston were not free to move, we would still have $T_2 = 330.2 \text{ K}$ but the volume of each gas would remain constant in this case:

$$\begin{aligned}\Delta S_{N_2} &= m \left(c_v \ln \frac{T_2}{T_1} - R \ln \frac{v_2}{v_1} \right)_{N_2} = (4.772 \text{ kg})(0.743 \text{ kJ/kg} \cdot \text{K}) \ln \frac{329 \text{ K}}{353 \text{ K}} = -0.2492 \text{ kJ/K} \\ \Delta S_{He} &= m \left(c_v \ln \frac{T_2}{T_1} - R \ln \frac{v_2}{v_1} \right)_{He} = (0.8079 \text{ kg})(3.1156 \text{ kJ/kg} \cdot \text{K}) \ln \frac{329 \text{ K}}{353 \text{ K}} = 0.2494 \text{ kJ/K} \\ S_{\text{gen}} &= \Delta S_{N_2} + \Delta S_{He} + \Delta S_{\text{piston}} = -0.2492 + 0.2494 + 0.021 = 0.02104 \text{ kJ/K}\end{aligned}$$

and

$$X_{\text{destroyed}} = T_0 S_{\text{gen}} = (298 \text{ K})(0.02104 \text{ kJ/K}) = \mathbf{6.27 \text{ kJ}}$$

8-108E Argon enters an adiabatic turbine at a specified state with a specified mass flow rate, and leaves at a specified pressure. The isentropic and second-law efficiencies of the turbine are to be determined.

Assumptions 1 This is a steady-flow process since there is no change with time. **2** Kinetic and potential energy changes are negligible. **3** The device is adiabatic and thus heat transfer is negligible. **4** Argon is an ideal gas with constant specific heats.

Properties The specific heat ratio of argon is $k = 1.667$. The constant pressure specific heat of argon is $c_p = 0.1253$ Btu/lbm·R. The gas constant is $R = 0.04971$ Btu/lbm·R (Table A-2E).

Analysis There is only one inlet and one exit, and thus $\dot{m}_1 = \dot{m}_2 = \dot{m}$. We take the isentropic turbine as the system, which is a control volume since mass crosses the boundary. The energy balance for this steady-flow system can be expressed in the rate form as

$$\underbrace{\dot{E}_{\text{in}} - \dot{E}_{\text{out}}}_{\substack{\text{Rate of net energy transfer} \\ \text{by heat, work, and mass}}} = \underbrace{\Delta \dot{E}_{\text{system}}}_{\substack{\text{Rate of change in internal, kinetic,} \\ \text{potential, etc. energies}}} \stackrel{\neq 0 \text{ (steady)}}{=} 0$$

$$\dot{E}_{\text{in}} = \dot{E}_{\text{out}}$$

$$\dot{m}h_1 = \dot{W}_{s,\text{out}} + \dot{m}h_{2s} \quad (\text{since } \dot{Q} \cong \Delta \text{ke} \cong \Delta \text{pe} \cong 0)$$

$$\dot{W}_{s,\text{out}} = \dot{m}(h_1 - h_{2s})$$

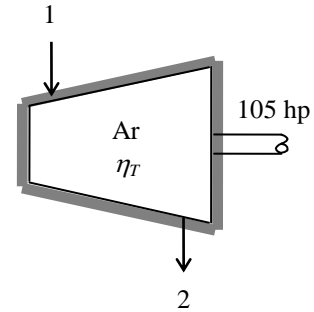

From the isentropic relations,

$$T_{2s} = T_1 \left(\frac{P_{2s}}{P_1} \right)^{(k-1)/k} = (1760 \text{ R}) \left(\frac{20 \text{ psia}}{200 \text{ psia}} \right)^{0.667/1.667} = 700.5 \text{ R}$$

Then the power output of the isentropic turbine becomes

$$\dot{W}_{s,\text{out}} = \dot{m}c_p(T_1 - T_{2s}) = (40 \text{ lbm/min})(0.1253 \text{ Btu/lbm} \cdot \text{R})(1760 - 700.5) \text{ R} \left(\frac{1 \text{ hp}}{42.41 \text{ Btu/min}} \right) = 125.2 \text{ hp}$$

Then the isentropic efficiency of the turbine is determined from

$$\eta_T = \frac{\dot{W}_{a,\text{out}}}{\dot{W}_{s,\text{out}}} = \frac{105 \text{ hp}}{125.2 \text{ hp}} = 0.8385 = \mathbf{83.9\%}$$

(b) Using the steady-flow energy balance relation $\dot{W}_{a,\text{out}} = \dot{m}c_p(T_1 - T_2)$ above, the actual turbine exit temperature is determined to be

$$T_2 = T_1 - \frac{\dot{W}_{a,\text{out}}}{\dot{m}c_p} = 1300^\circ\text{F} - \frac{105 \text{ hp}}{(40 \text{ lbm/min})(0.1253 \text{ Btu/lbm} \cdot \text{R})} \left(\frac{42.41 \text{ Btu/min}}{1 \text{ hp}} \right) = 411.6^\circ\text{F} = 871.6 \text{ R}$$

The entropy generation during this process can be determined from an entropy balance on the turbine,

$$\underbrace{\dot{S}_{\text{in}} - \dot{S}_{\text{out}}}_{\substack{\text{Rate of net entropy transfer} \\ \text{by heat and mass}}} + \underbrace{\dot{S}_{\text{gen}}}_{\substack{\text{Rate of entropy} \\ \text{generation}}} = \underbrace{\Delta \dot{S}_{\text{system}}}_{\substack{\text{Rate of change} \\ \text{of entropy}}} \stackrel{\neq 0}{=} 0$$

$$\dot{m}s_1 - \dot{m}s_2 + \dot{S}_{\text{gen}} = 0$$

$$\dot{S}_{\text{gen}} = \dot{m}(s_2 - s_1)$$

where

$$s_2 - s_1 = c_p \ln \frac{T_2}{T_1} - R \ln \frac{P_2}{P_1}$$

$$= (0.1253 \text{ Btu/lbm} \cdot \text{R}) \ln \frac{871.6 \text{ R}}{1760 \text{ R}} - (0.04971 \text{ Btu/lbm} \cdot \text{R}) \ln \frac{20 \text{ psia}}{200 \text{ psia}}$$

$$= 0.02641 \text{ Btu/lbm} \cdot \text{R}$$

The exergy destroyed during a process can be determined from an exergy balance or directly from its definition

$$X_{\text{destroyed}} = T_0 S_{\text{gen}}$$

$$\begin{aligned} \dot{X}_{\text{destroyed}} &= T_0 \dot{S}_{\text{gen}} = \dot{m} T_0 (s_2 - s_1) \\ &= (40 \text{ lbm/min})(537 \text{ R})(0.02641 \text{ Btu/lbm} \cdot \text{R}) \left(\frac{1 \text{ hp}}{42.41 \text{ Btu/min}} \right) \\ &= 13.37 \text{ hp} \end{aligned}$$

Then the reversible power and second-law efficiency become

$$\dot{W}_{\text{rev,out}} = \dot{W}_{a,\text{out}} + \dot{X}_{\text{destroyed}} = 105 + 13.37 = 118.4 \text{ hp}$$

and

$$\eta_{\text{II}} = \frac{\dot{W}_{a,\text{out}}}{\dot{W}_{\text{rev,out}}} = \frac{105 \text{ hp}}{118.4 \text{ hp}} = 0.887 = \mathbf{88.7\%}$$

8-109  The feedwater of a steam power plant is preheated using steam extracted from the turbine. The ratio of the mass flow rates of the extracted steam and the feedwater are to be determined.

Assumptions 1 This is a steady-flow process since there is no change with time. **2** Kinetic and potential energy changes are negligible. **3** Heat loss from the device to the surroundings is negligible and thus heat transfer from the hot fluid is equal to the heat transfer to the cold fluid.

Properties The properties of steam and feedwater are (Tables A-4 through A-6)

$$\left. \begin{array}{l} P_1 = 1.6 \text{ MPa} \\ T_1 = 250^\circ\text{C} \end{array} \right\} \begin{array}{l} h_1 = 2919.9 \text{ kJ/kg} \\ s_1 = 6.6753 \text{ kJ/kg} \cdot \text{K} \end{array}$$

$$\left. \begin{array}{l} P_2 = 1.6 \text{ MPa} \\ \text{sat. liquid} \end{array} \right\} \begin{array}{l} h_2 = h_f @ 1.6 \text{ MPa} = 858.44 \text{ kJ/kg} \\ s_2 = s_f @ 1.6 \text{ MPa} = 2.3435 \text{ kJ/kg} \cdot \text{K} \\ T_2 = 201.4^\circ\text{C} \end{array}$$

$$\left. \begin{array}{l} P_3 = 4 \text{ MPa} \\ T_3 = 30^\circ\text{C} \end{array} \right\} \begin{array}{l} h_3 \cong h_f @ 30^\circ\text{C} = 129.37 \text{ kJ/kg} \\ s_3 \cong s_f @ 30^\circ\text{C} = 0.4355 \text{ kJ/kg} \cdot \text{K} \end{array}$$

$$\left. \begin{array}{l} P_4 = 4 \text{ MPa} \\ T_4 = T_2 - 10^\circ\text{C} \cong 191.4^\circ\text{C} \end{array} \right\} \begin{array}{l} h_4 \cong h_f @ 191.4^\circ\text{C} = 814.78 \text{ kJ/kg} \\ s_4 \cong s_f @ 191.4^\circ\text{C} = 2.2446 \text{ kJ/kg} \cdot \text{K} \end{array}$$

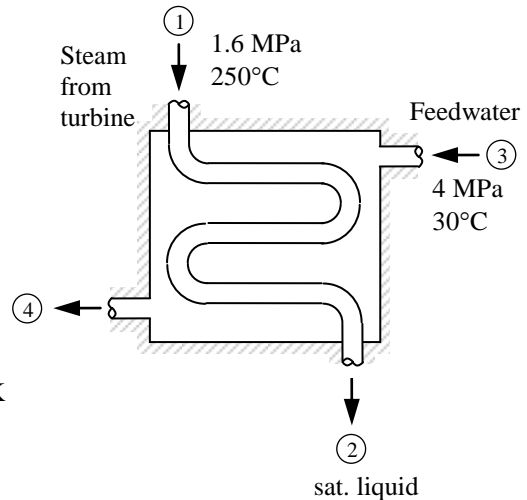

Analysis (a) We take the heat exchanger as the system, which is a control volume. The mass and energy balances for this steady-flow system can be expressed in the rate form as follows:

Mass balance (for each fluid stream):

$$\dot{m}_{\text{in}} - \dot{m}_{\text{out}} = \Delta \dot{m}_{\text{system}} \stackrel{\approx 0 \text{ (steady)}}{=} 0 \rightarrow \dot{m}_{\text{in}} = \dot{m}_{\text{out}} \rightarrow \dot{m}_1 = \dot{m}_2 = \dot{m}_s \quad \text{and} \quad \dot{m}_3 = \dot{m}_4 = \dot{m}_{fw}$$

Energy balance (for the heat exchanger):

$$\underbrace{\dot{E}_{\text{in}} - \dot{E}_{\text{out}}}_{\text{Rate of net energy transfer by heat, work, and mass}} = \underbrace{\Delta \dot{E}_{\text{system}}}_{\text{Rate of change in internal, kinetic, potential, etc. energies}} \stackrel{\approx 0 \text{ (steady)}}{=} 0 \rightarrow \dot{E}_{\text{in}} = \dot{E}_{\text{out}}$$

$$\dot{m}_1 h_1 + \dot{m}_3 h_3 = \dot{m}_2 h_2 + \dot{m}_4 h_4 \quad (\text{since } \dot{Q} = \dot{W} = \Delta \text{ke} \cong \Delta \text{pe} \cong 0)$$

Combining the two, $\dot{m}_s (h_2 - h_1) = \dot{m}_{fw} (h_3 - h_4)$

Dividing by \dot{m}_{fw} and substituting,

$$\frac{\dot{m}_s}{\dot{m}_{fw}} = \frac{h_3 - h_4}{h_2 - h_1} = \frac{(129.37 - 814.78) \text{ kJ/kg}}{(858.44 - 2919.9) \text{ kJ/kg}} = \mathbf{0.3325}$$

(b) The entropy generation during this process per unit mass of feedwater can be determined from an entropy balance on the feedwater heater expressed in the rate form as

$$\underbrace{\dot{S}_{\text{in}} - \dot{S}_{\text{out}}}_{\text{Rate of net entropy transfer by heat and mass}} + \underbrace{\dot{S}_{\text{gen}}}_{\text{Rate of entropy generation}} = \underbrace{\Delta \dot{S}_{\text{system}}}_{\text{Rate of change of entropy}} \stackrel{\approx 0}{=} 0$$

$$\dot{m}_1 s_1 - \dot{m}_2 s_2 + \dot{m}_3 s_3 - \dot{m}_4 s_4 + \dot{S}_{\text{gen}} = 0$$

$$\dot{m}_s (s_1 - s_2) + \dot{m}_{fw} (s_3 - s_4) + \dot{S}_{\text{gen}} = 0$$

$$\frac{\dot{S}_{\text{gen}}}{\dot{m}_{fw}} = \frac{\dot{m}_s}{\dot{m}_{fw}} (s_2 - s_1) + (s_4 - s_3) = (0.3325)(2.3435 - 6.6753) + (2.2446 - 0.4355) = 0.3688 \text{ kJ/K} \cdot \text{kg fw}$$

Noting that this process involves no actual work, the reversible work and exergy destruction become equivalent since

$$X_{\text{destroyed}} = W_{\text{rev,out}} - W_{\text{act,out}} \rightarrow W_{\text{rev,out}} = X_{\text{destroyed}}$$

The exergy destroyed during a process can be determined from an exergy balance or directly from its definition $X_{\text{destroyed}} = T_0 S_{\text{gen}}$,

$$X_{\text{destroyed}} = T_0 S_{\text{gen}} = (298 \text{ K})(0.3688 \text{ kJ/K} \cdot \text{kg fw}) = \mathbf{109.9 \text{ kJ/kg feedwater}}$$



8-110 Problem 8-109 is reconsidered. The effect of the state of the steam at the inlet of the feedwater heater on the ratio of mass flow rates and the reversible power is to be investigated.

Analysis Using EES, the problem is solved as follows:

"Input Data"

"Steam (let st=steam data):"

Fluid\$='Steam_IAPWS'

T_st[1]=250 [C]

{P_st[1]=1600 [kPa]}

P_st[2] = P_st[1]

x_st[2]=0 "saturated liquid, quality = 0%"

T_st[2]=temperature(steam, P=P_st[2], x=x_st[2])

"Feedwater (let fw=feedwater data):"

T_fw[1]=30 [C]

P_fw[1]=4000 [kPa]

P_fw[2]=P_fw[1] "assume no pressure drop for the feedwater"

T_fw[2]=T_st[2]-10

"Surroundings:"

T_o = 25 [C]

P_o = 100 [kPa] "Assumed value for the surroundings pressure"

"Conservation of mass:"

"There is one entrance, one exit for both the steam and feedwater."

"Steam: m_dot_st[1] = m_dot_st[2]"

"Feedwater: m_dot_fw[1] = m_dot_fw[2]"

"Let m_ratio = m_dot_st/m_dot_fw"

"Conservation of Energy:"

"We write the conservation of energy for steady-flow control volume having two entrances and two exits with the above assumptions. Since neither of the flow rates is known or can be found, write the conservation of energy per unit mass of the feedwater."

E_in - E_out = DELTAE_cv

DELTA E_cv=0 "Steady-flow requirement"

E_in = m_ratio*h_st[1] + h_fw[1]

h_st[1]=enthalpy(Fluid\$, T=T_st[1], P=P_st[1])

h_fw[1]=enthalpy(Fluid\$, T=T_fw[1], P=P_fw[1])

E_out = m_ratio*h_st[2] + h_fw[2]

h_fw[2]=enthalpy(Fluid\$, T=T_fw[2], P=P_fw[2])

h_st[2]=enthalpy(Fluid\$, x=x_st[2], P=P_st[2])

"The reversible work is given by Eq. 7-47, where the heat transfer is zero (the feedwater heater is adiabatic) and the Exergy destroyed is set equal to zero"

W_rev = m_ratio*(Psi_st[1]-Psi_st[2]) +(Psi_fw[1]-Psi_fw[2])

Psi_st[1]=h_st[1]-h_st_o -(T_o + 273)*(s_st[1]-s_st_o)

s_st[1]=entropy(Fluid\$, T=T_st[1], P=P_st[1])

h_st_o=enthalpy(Fluid\$, T=T_o, P=P_o)

s_st_o=entropy(Fluid\$, T=T_o, P=P_o)

Psi_st[2]=h_st[2]-h_st_o -(T_o + 273)*(s_st[2]-s_st_o)

s_st[2]=entropy(Fluid\$, x=x_st[2], P=P_st[2])

Psi_fw[1]=h_fw[1]-h_fw_o -(T_o + 273)*(s_fw[1]-s_fw_o)

h_fw_o=enthalpy(Fluid\$, T=T_o, P=P_o)

s_fw[1]=entropy(Fluid\$, T=T_fw[1], P=P_fw[1])

s_fw_o=entropy(Fluid\$, T=T_o, P=P_o)

Psi_fw[2]=h_fw[2]-h_fw_o -(T_o + 273)*(s_fw[2]-s_fw_o)

s_fw[2]=entropy(Fluid\$, T=T_fw[2], P=P_fw[2])

$P_{st,1}$ [kPa]	m_{ratio} [kg/kg]	W_{rev} [kJ/kg]
200	0.1361	42.07
400	0.1843	59.8
600	0.2186	72.21
800	0.2466	82.06
1000	0.271	90.35
1200	0.293	97.58
1400	0.3134	104
1600	0.3325	109.9
1800	0.3508	115.3
2000	0.3683	120.3

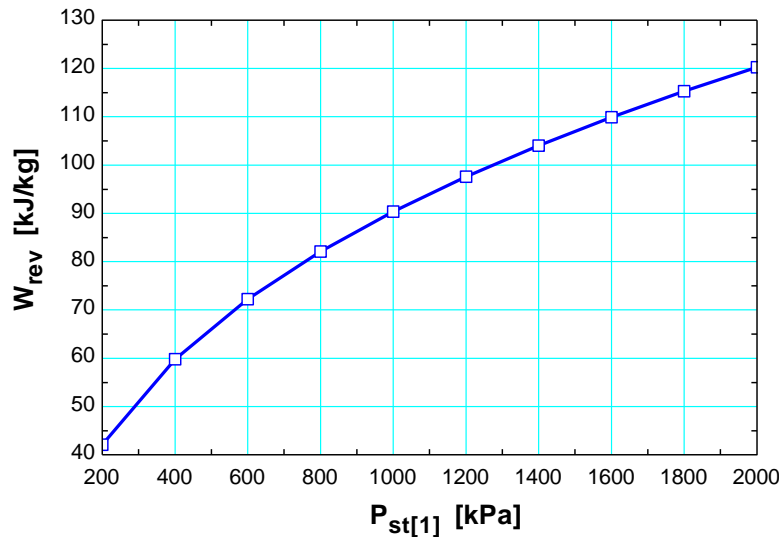
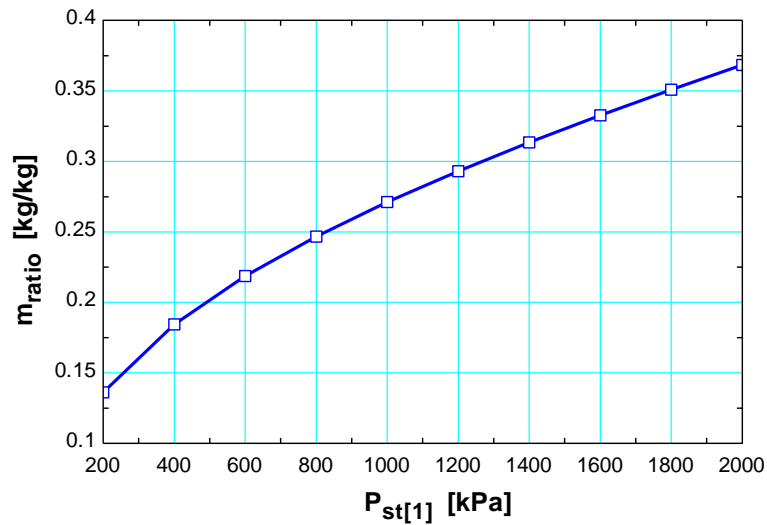

8-111 A 1-ton (1000 kg) of water is to be cooled in a tank by pouring ice into it. The final equilibrium temperature in the tank and the exergy destruction are to be determined.

Assumptions 1 Thermal properties of the ice and water are constant. **2** Heat transfer to the water tank is negligible. **3** There is no stirring by hand or a mechanical device (it will add energy).

Properties The specific heat of water at room temperature is $c = 4.18 \text{ kJ/kg}\cdot^\circ\text{C}$, and the specific heat of ice at about 0°C is $c = 2.11 \text{ kJ/kg}\cdot^\circ\text{C}$ (Table A-3). The melting temperature and the heat of fusion of ice at 1 atm are 0°C and 333.7 kJ/kg .

Analysis (a) We take the ice and the water as the system, and disregard any heat transfer between the system and the surroundings.

Then the energy balance for this process can be written as

$$\underbrace{E_{\text{in}} - E_{\text{out}}}_{\substack{\text{Net energy transfer} \\ \text{by heat, work, and mass}}} = \underbrace{\Delta E_{\text{system}}}_{\substack{\text{Change in internal, kinetic,} \\ \text{potential, etc. energies}}}$$

$$0 = \Delta U$$

$$0 = \Delta U_{\text{ice}} + \Delta U_{\text{water}}$$

$$[mc(0^\circ\text{C} - T_1)_{\text{solid}} + mh_{\text{if}} + mc(T_2 - 0^\circ\text{C})_{\text{liquid}}]_{\text{ice}} + [mc(T_2 - T_1)]_{\text{water}} = 0$$

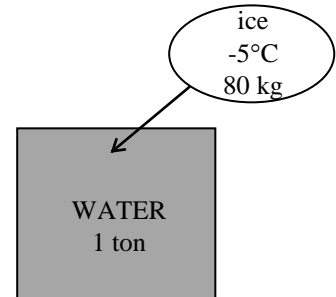

Substituting,

$$(80 \text{ kg})\{(2.11 \text{ kJ/kg}\cdot^\circ\text{C})[0 - (-5)]^\circ\text{C} + 333.7 \text{ kJ/kg} + (4.18 \text{ kJ/kg}\cdot^\circ\text{C})(T_2 - 0^\circ\text{C})\} \\ + (1000 \text{ kg})(4.18 \text{ kJ/kg}\cdot^\circ\text{C})(T_2 - 20^\circ\text{C}) = 0$$

It gives

$$T_2 = \mathbf{12.42^\circ\text{C}}$$

which is the final equilibrium temperature in the tank.

(b) We take the ice and the water as our system, which is a closed system. Considering that the tank is well-insulated and thus there is no heat transfer, the entropy balance for this closed system can be expressed as

$$\underbrace{S_{\text{in}} - S_{\text{out}}}_{\substack{\text{Net entropy transfer} \\ \text{by heat and mass}}} + \underbrace{S_{\text{gen}}}_{\substack{\text{Entropy} \\ \text{generation}}} = \underbrace{\Delta S_{\text{system}}}_{\substack{\text{Change} \\ \text{in entropy}}}$$

$$0 + S_{\text{gen}} = \Delta S_{\text{ice}} + \Delta S_{\text{water}}$$

where

$$\Delta S_{\text{water}} = \left(mc \ln \frac{T_2}{T_1} \right)_{\text{water}} = (1000 \text{ kg})(4.18 \text{ kJ/kg}\cdot\text{K}) \ln \frac{285.42 \text{ K}}{293 \text{ K}} = -109.590 \text{ kJ/K}$$

$$\Delta S_{\text{ice}} = \left(\Delta S_{\text{solid}} + \Delta S_{\text{melting}} + \Delta S_{\text{liquid}} \right)_{\text{ice}}$$

$$= \left(\left(mc \ln \frac{T_{\text{melting}}}{T_1} \right)_{\text{solid}} + \frac{mh_{\text{if}}}{T_{\text{melting}}} + \left(mc \ln \frac{T_2}{T_1} \right)_{\text{liquid}} \right)_{\text{ice}}$$

$$= (80 \text{ kg}) \left((2.11 \text{ kJ/kg}\cdot\text{K}) \ln \frac{273 \text{ K}}{268 \text{ K}} + \frac{333.7 \text{ kJ/kg}}{273 \text{ K}} + (4.18 \text{ kJ/kg}\cdot\text{K}) \ln \frac{285.42 \text{ K}}{273 \text{ K}} \right)$$

$$= 115.783 \text{ kJ/K}$$

$$\text{Then, } S_{\text{gen}} = \Delta S_{\text{water}} + \Delta S_{\text{ice}} = -109.590 + 115.783 = 6.193 \text{ kJ/K}$$

The exergy destroyed during a process can be determined from an exergy balance or directly from its definition $X_{\text{destroyed}} = T_0 S_{\text{gen}}$,

$$X_{\text{destroyed}} = T_0 S_{\text{gen}} = (293 \text{ K})(6.193 \text{ kJ/K}) = \mathbf{1815 \text{ kJ}}$$

8-112 The heating of a passive solar house at night is to be assisted by solar heated water. The amount of heating this water will provide to the house at night and the exergy destruction during this heat transfer process are to be determined.

Assumptions 1 Water is an incompressible substance with constant specific heats. **2** The energy stored in the glass containers themselves is negligible relative to the energy stored in water. **3** The house is maintained at 22°C at all times. **4** The outdoor temperature is given to be 5°C.

Properties The density and specific heat of water at room temperature are $\rho = 997 \text{ kg/m}^3$ and $c = 4.18 \text{ kJ/kg}\cdot^\circ\text{C}$ (Table A-3).

Analysis The total mass of water is

$$m_w = \rho V = (997 \text{ kg/m}^3)(0.350 \text{ m}^3) = 348.95 \text{ kg}$$

The amount of heat this water storage system can provide is determined from an energy balance on the 350-L water storage system

$$\underbrace{E_{\text{in}} - E_{\text{out}}}_{\substack{\text{Net energy transfer} \\ \text{by heat, work, and mass}}} = \underbrace{\Delta E_{\text{system}}}_{\substack{\text{Change in internal, kinetic,} \\ \text{potential, etc. energies}}}$$

$$-Q_{\text{out}} = \Delta U_{\text{system}} = mc(T_2 - T_1)_{\text{water}}$$

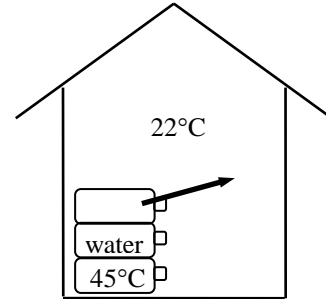

Substituting,

$$Q_{\text{out}} = (348.95 \text{ kg})(4.18 \text{ kJ/kg}\cdot^\circ\text{C})(45 - 22)^\circ\text{C} = 33,548 \text{ kJ} \cong \mathbf{33,550 \text{ kJ}}$$

The entropy generated during this process is determined by applying the entropy balance on an *extended system* that includes the water and its immediate surroundings so that the boundary temperature of the extended system is the environment temperature at all times. It gives

$$\underbrace{S_{\text{in}} - S_{\text{out}}}_{\substack{\text{Net entropy transfer} \\ \text{by heat and mass}}} + \underbrace{S_{\text{gen}}}_{\substack{\text{Entropy} \\ \text{generation}}} = \underbrace{\Delta S_{\text{system}}}_{\substack{\text{Change} \\ \text{in entropy}}}$$

$$-\frac{Q_{\text{out}}}{T_{\text{b,out}}} + S_{\text{gen}} = \Delta S_{\text{water}}$$

Substituting,

$$S_{\text{gen}} = \Delta S_{\text{water}} + \frac{Q_{\text{out}}}{T_{\text{b,out}}} = \left(mc \ln \frac{T_2}{T_1} \right)_{\text{water}} + \frac{Q_{\text{out}}}{T_{\text{room}}}$$

$$= (348.95 \text{ kg})(4.18 \text{ kJ/kg}\cdot\text{K}) \ln \frac{295 \text{ K}}{318 \text{ K}} + \frac{33,548 \text{ kJ}}{295 \text{ K}}$$

$$= 4.215 \text{ kJ/K}$$

The exergy destroyed during a process can be determined from an exergy balance or directly from its definition $X_{\text{destroyed}} = T_0 S_{\text{gen}}$,

$$X_{\text{destroyed}} = T_0 S_{\text{gen}} = (278 \text{ K})(4.215 \text{ kJ/K}) = \mathbf{1172 \text{ kJ}}$$

8-113 The heating of a passive solar house at night is to be assisted by solar heated water. The length of time that the electric heating system would run that night, the exergy destruction, and the minimum work input required that night are to be determined.

Assumptions 1 Water is an incompressible substance with constant specific heats. 2 The energy stored in the glass containers themselves is negligible relative to the energy stored in water. 3 The house is maintained at 22°C at all times. 4 The environment temperature is given to be $T_0 = 5^\circ\text{C}$.

Properties The density and specific heat of water at room temperature are $\rho = 1 \text{ kg/L}$ and $c = 4.18 \text{ kJ/kg}\cdot^\circ\text{C}$ (Table A-3).

Analysis (a) The total mass of water is

$$m_w = \rho V = (1 \text{ kg/L})(50 \times 20 \text{ L}) = 1000 \text{ kg}$$

Taking the contents of the house, including the water as our system, the energy balance relation can be written as

$$\underbrace{E_{\text{in}} - E_{\text{out}}}_{\substack{\text{Net energy transfer} \\ \text{by heat, work, and mass}}} = \underbrace{\Delta E_{\text{system}}}_{\substack{\text{Change in internal, kinetic,} \\ \text{potential, etc. energies}}}$$

$$W_{e,\text{in}} - Q_{\text{out}} = \Delta U = (\Delta U)_{\text{water}} + (\Delta U)_{\text{air}} \stackrel{\approx 0}{\approx}$$

$$= (\Delta U)_{\text{water}} = mc(T_2 - T_1)_{\text{water}}$$

or $\dot{W}_{e,\text{in}} \Delta t - Q_{\text{out}} = [mc(T_2 - T_1)]_{\text{water}}$

Substituting,

$$(15 \text{ kJ/s})\Delta t - (50,000 \text{ kJ/h})(10 \text{ h}) = (1000 \text{ kg})(4.18 \text{ kJ/kg}\cdot^\circ\text{C})(22 - 80)^\circ\text{C}$$

It gives

$$\Delta t = 17,170 \text{ s} = \mathbf{4.77 \text{ h}}$$

(b) We take the house as the system, which is a closed system. The entropy generated during this process is determined by applying the entropy balance on an *extended system* that includes the house and its immediate surroundings so that the boundary temperature of the extended system is the temperature of the surroundings at all times. The entropy balance for the extended system can be expressed as

$$\underbrace{S_{\text{in}} - S_{\text{out}}}_{\substack{\text{Net entropy transfer} \\ \text{by heat and mass}}} + \underbrace{S_{\text{gen}}}_{\substack{\text{Entropy} \\ \text{generation}}} = \underbrace{\Delta S_{\text{system}}}_{\substack{\text{Change} \\ \text{in entropy}}}$$

$$-\frac{Q_{\text{out}}}{T_{\text{b,out}}} + S_{\text{gen}} = \Delta S_{\text{water}} + \Delta S_{\text{air}} \stackrel{\approx 0}{\approx} = \Delta S_{\text{water}}$$

since the state of air in the house remains unchanged. Then the entropy generated during the 10-h period that night is

$$S_{\text{gen}} = \Delta S_{\text{water}} + \frac{Q_{\text{out}}}{T_{\text{b,out}}} = \left(mc \ln \frac{T_2}{T_1} \right)_{\text{water}} + \frac{Q_{\text{out}}}{T_0}$$

$$= (1000 \text{ kg})(4.18 \text{ kJ/kg}\cdot\text{K}) \ln \frac{295 \text{ K}}{353 \text{ K}} + \frac{500,000 \text{ kJ}}{278 \text{ K}} = 1048 \text{ kJ/K}$$

The exergy destroyed during a process can be determined from an exergy balance or directly from its definition $X_{\text{destroyed}} = T_0 S_{\text{gen}}$,

$$X_{\text{destroyed}} = T_0 S_{\text{gen}} = (278 \text{ K})(1048 \text{ kJ/K}) = \mathbf{291,400 \text{ kJ}}$$

(c) The actual work input during this process is

$$W_{\text{act,in}} = \dot{W}_{\text{act,in}} \Delta t = (15 \text{ kJ/s})(17,170 \text{ s}) = 257,550 \text{ kJ}$$

The minimum work with which this process could be accomplished is the reversible work input, $W_{\text{rev,in}}$, which can be determined directly from

$$W_{\text{rev,in}} = W_{\text{act,in}} - X_{\text{destroyed}} = 257,550 - 291,400 = -33,850 \text{ kJ}$$

$$W_{\text{rev,out}} = 33,850 \text{ kJ} = \mathbf{9.40 \text{ kWh}}$$

That is, 9.40 kWh of electricity could be *generated* while heating the house by the solar heated water (instead of consuming electricity) if the process was done reversibly.

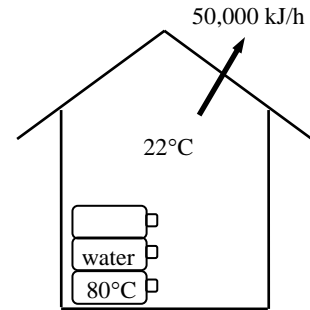

8-114 An evacuated bottle is surrounded by atmospheric air. A valve is opened, and air is allowed to fill the bottle. The amount of heat transfer through the wall of the bottle when thermal and mechanical equilibrium is established and the amount of exergy destroyed are to be determined.

Assumptions 1 This is an unsteady process since the conditions within the device are changing during the process, but it can be analyzed as a uniform-flow process since the state of fluid at the inlet remains constant. **2** Air is an ideal gas. **3** Kinetic and potential energies are negligible. **4** There are no work interactions involved. **5** The direction of heat transfer is to the air in the bottle (will be verified).

Properties The gas constant of air is $0.287 \text{ kPa}\cdot\text{m}^3/\text{kg}\cdot\text{K}$ (Table A-1).

Analysis We take the bottle as the system, which is a control volume since mass crosses the boundary. Noting that the microscopic energies of flowing and nonflowing fluids are represented by enthalpy h and internal energy u , respectively, the mass and energy balances can be expressed as

$$\text{Mass balance: } m_{\text{in}} - m_{\text{out}} = \Delta m_{\text{system}} \rightarrow m_i = m_2 \quad (\text{since } m_{\text{out}} = m_{\text{initial}} = 0)$$

Energy balance:

$$\underbrace{E_{\text{in}} - E_{\text{out}}}_{\substack{\text{Net energy transfer} \\ \text{by heat, work, and mass}}} = \underbrace{\Delta E_{\text{system}}}_{\substack{\text{Change in internal, kinetic,} \\ \text{potential, etc. energies}}}$$

$$Q_{\text{in}} + m_i h_i = m_2 u_2 \quad (\text{since } W \cong E_{\text{out}} = E_{\text{initial}} = ke \cong pe \cong 0)$$

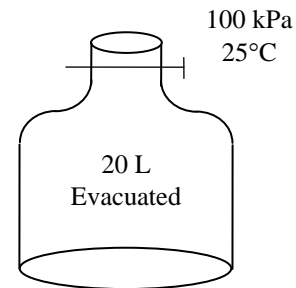

Combining the two balances:

$$Q_{\text{in}} = m_2(u_2 - h_i)$$

where

$$m_2 = \frac{P_2 V}{RT_2} = \frac{(100 \text{ kPa})(0.020 \text{ m}^3)}{(0.287 \text{ kPa}\cdot\text{m}^3/\text{kg}\cdot\text{K})(298 \text{ K})} = 0.02338 \text{ kg}$$

$$T_i = T_2 = 298 \text{ K} \xrightarrow{\text{Table A-17}} \begin{aligned} h_i &= 298.18 \text{ kJ/kg} \\ u_2 &= 212.64 \text{ kJ/kg} \end{aligned}$$

Substituting,

$$Q_{\text{in}} = (0.02338 \text{ kg})(212.64 - 298.18) \text{ kJ/kg} = -2.0 \text{ kJ} \rightarrow Q_{\text{out}} = \mathbf{2.0 \text{ kJ}}$$

Note that the negative sign for heat transfer indicates that the assumed direction is wrong. Therefore, we reversed the direction.

The entropy generated during this process is determined by applying the entropy balance on an *extended system* that includes the bottle and its immediate surroundings so that the boundary temperature of the extended system is the temperature of the surroundings at all times. The entropy balance for it can be expressed as

$$\underbrace{S_{\text{in}} - S_{\text{out}}}_{\substack{\text{Net entropy transfer} \\ \text{by heat and mass}}} + \underbrace{S_{\text{gen}}}_{\substack{\text{Entropy} \\ \text{generation}}} = \underbrace{\Delta S_{\text{system}}}_{\substack{\text{Change} \\ \text{in entropy}}}$$

$$m_i s_i - \frac{Q_{\text{out}}}{T_{\text{b,in}}} + S_{\text{gen}} = \Delta S_{\text{tank}} = m_2 s_2 - m_1 s_1^{\phi_0} = m_2 s_2$$

Therefore, the total entropy generated during this process is

$$S_{\text{gen}} = -m_i s_i + m_2 s_2 + \frac{Q_{\text{out}}}{T_{\text{b,out}}} = m_2 (s_2 - s_i)^{\phi_0} + \frac{Q_{\text{out}}}{T_{\text{b,out}}} = \frac{Q_{\text{out}}}{T_{\text{surr}}} = \frac{2.0 \text{ kJ}}{298 \text{ K}} = 0.006711 \text{ kJ/K}$$

The exergy destroyed during a process can be determined from an exergy balance or directly from its definition $X_{\text{destroyed}} = T_0 S_{\text{gen}}$,

$$X_{\text{destroyed}} = T_0 S_{\text{gen}} = (298 \text{ K})(0.006711 \text{ kJ/K}) = \mathbf{2.0 \text{ kJ}}$$

8-115 Argon gas in a piston–cylinder device expands isothermally as a result of heat transfer from a furnace. The useful work output, the exergy destroyed, and the reversible work are to be determined.

Assumptions 1 Argon at specified conditions can be treated as an ideal gas since it is well above its critical temperature of 151 K. **2** The kinetic and potential energies are negligible.

Analysis We take the *argon gas* contained within the piston–cylinder device as the system. This is a *closed system* since no mass crosses the system boundary during the process. We note that heat is transferred to the system

from a source at 1200 K, but there is no heat exchange with the environment at 300 K. Also, the temperature of the system remains constant during the expansion process, and its volume doubles, that is, $T_2 = T_1$ and $V_2 = 2V_1$.

(a) The only work interaction involved during this isothermal process is the quasi-equilibrium boundary work, which is determined from

$$W = W_b = \int_1^2 PdV = P_1 V_1 \ln \frac{V_2}{V_1} = (350 \text{ kPa})(0.01 \text{ m}^3) \ln \frac{0.02 \text{ m}^3}{0.01 \text{ m}^3} = 2.43 \text{ kPa} \cdot \text{m}^3 = 2.43 \text{ kJ}$$

This is the total boundary work done by the argon gas. Part of this work is done against the atmospheric pressure P_0 to push the air out of the way, and it cannot be used for any useful purpose. It is determined from

$$W_{\text{sur}} = P_0 (V_2 - V_1) = (100 \text{ kPa})(0.02 - 0.01) \text{ m}^3 = 1 \text{ kPa} \cdot \text{m}^3 = 1 \text{ kJ}$$

The useful work is the difference between these two:

$$W_u = W - W_{\text{sur}} = 2.43 - 1 = \mathbf{1.43 \text{ kJ}}$$

That is, 1.43 kJ of the work done is available for creating a useful effect such as rotating a shaft. Also, the heat transfer from the furnace to the system is determined from an energy balance on the system to be

$$\begin{aligned} \underbrace{E_{\text{in}} - E_{\text{out}}}_{\substack{\text{Net energy transfer} \\ \text{by heat, work, and mass}}} &= \underbrace{\Delta E_{\text{system}}}_{\substack{\text{Change in internal, kinetic,} \\ \text{potential, etc. energies}}} \\ Q_{\text{in}} - Q_{\text{b,out}} = \Delta U = mc_v \Delta T &= 0 \\ Q_{\text{in}} = Q_{\text{b,out}} &= 2.43 \text{ kJ} \end{aligned}$$

(b) The exergy destroyed during a process can be determined from an exergy balance, or directly from $X_{\text{destroyed}} = T_0 S_{\text{gen}}$. We will use the second approach since it is usually easier. But first we determine the entropy generation by

applying an entropy balance on an *extended system* (system + immediate surroundings), which includes the temperature gradient zone between the cylinder and the furnace so that the temperature at the boundary where heat

transfer occurs is $T_R = 1200 \text{ K}$. This way, the entropy generation associated with the heat transfer is included. Also, the entropy change of the argon gas can be determined from Q/T_{sys} since its temperature remains constant.

$$\begin{aligned} \underbrace{S_{\text{in}} - S_{\text{out}}}_{\substack{\text{Net entropy transfer} \\ \text{by heat and mass}}} + \underbrace{S_{\text{gen}}}_{\substack{\text{Entropy} \\ \text{generation}}} &= \underbrace{\Delta S_{\text{system}}}_{\substack{\text{Change} \\ \text{in entropy}}} \\ \frac{Q}{T_R} + S_{\text{gen}} &= \Delta S_{\text{sys}} = \frac{Q}{T_{\text{sys}}} \end{aligned}$$

Therefore,

$$S_{\text{gen}} = \frac{Q}{T_{\text{sys}}} - \frac{Q}{T_R} = \frac{2.43 \text{ kJ}}{400 \text{ K}} - \frac{2.43 \text{ kJ}}{1200 \text{ K}} = 0.00405 \text{ kJ/K}$$

and

$$X_{\text{dest}} = T_0 S_{\text{gen}} = (300 \text{ K})(0.00405 \text{ kJ/K}) = \mathbf{1.22 \text{ kJ}}$$

(c) The reversible work, which represents the maximum useful work that could be produced $W_{\text{rev,out}}$, can be determined from the exergy balance by setting the exergy destruction equal to zero,

$$\begin{aligned}
 \underbrace{X_{\text{in}} - X_{\text{out}}}_{\substack{\text{Net exergy transfer} \\ \text{by heat, work, and mass}}} - \underbrace{X_{\text{destroyed}}}_{\substack{\text{Exergy} \\ \text{destruction}}} \stackrel{\text{reversible}}{=} \underbrace{\Delta X_{\text{system}}}_{\substack{\text{Change} \\ \text{in exergy}}} \\
 \left(1 - \frac{T_0}{T_b}\right) Q - W_{\text{rev,out}} = X_2 - X_1 \\
 = (U_2 - U_1) + P_0(V_2 - V_1) - T_0(S_2 - S_1) \\
 = 0 + W_{\text{surr}} - T_0 \frac{Q}{T_{\text{sys}}}
 \end{aligned}$$

since $\Delta KE = \Delta PE = 0$ and $\Delta U = 0$ (the change in internal energy of an ideal gas is zero during an isothermal process), and $\Delta S_{\text{sys}} = Q/T_{\text{sys}}$ for isothermal processes in the absence of any irreversibilities. Then,

$$\begin{aligned}
 W_{\text{rev,out}} &= T_0 \frac{Q}{T_{\text{sys}}} - W_{\text{surr}} + \left(1 - \frac{T_0}{T_R}\right) Q \\
 &= (300 \text{ K}) \frac{2.43 \text{ kJ}}{400 \text{ K}} - (1 \text{ kJ}) + \left(1 - \frac{300 \text{ K}}{1200 \text{ K}}\right) (2.43 \text{ kJ}) \\
 &= \mathbf{2.65 \text{ kJ}}
 \end{aligned}$$

Therefore, the useful work output would be 2.65 kJ instead of 1.43 kJ if the process were executed in a totally reversible manner.

Alternative Approach The reversible work could also be determined by applying the basics only, without resorting to exergy balance. This is done by replacing the irreversible portions of the process by reversible ones that create the same effect on the system. The useful work output of this idealized process (between the actual end states) is the reversible work. The only irreversibility the actual process involves is the heat transfer between the system and the furnace through a finite temperature difference. This irreversibility can be eliminated by operating a reversible heat engine between the furnace at 1200 K and the surroundings at 300 K. When 2.43 kJ of heat is supplied to this heat engine, it produces a work output of

$$W_{\text{HE}} = \eta_{\text{rev}} Q_H = \left(1 - \frac{T_L}{T_H}\right) Q_H = \left(1 - \frac{300 \text{ K}}{1200 \text{ K}}\right) (2.43 \text{ kJ}) = 1.82 \text{ kJ}$$

The 2.43 kJ of heat that was transferred to the system from the source is now extracted from the surrounding air at 300 K by a reversible heat pump that requires a work input of

$$W_{\text{HP,in}} = \frac{Q_H}{\text{COP}_{\text{HP}}} = \frac{Q_H}{T_H / (T_H - T_L)} = \frac{2.43 \text{ kJ}}{(400 \text{ K}) / (400 - 300) \text{ K}} = 0.61 \text{ kJ}$$

Then the net work output of this reversible process (i.e., the reversible work) becomes

$$W_{\text{rev}} = W_u + W_{\text{HE}} - W_{\text{HP,in}} = 1.43 + 1.82 - 0.61 = 2.64 \text{ kJ}$$

which is practically identical to the result obtained before. Also, the exergy destroyed is the difference between the reversible work and the useful work, and is determined to be

$$X_{\text{dest}} = W_{\text{rev,out}} - W_{u,\text{out}} = 2.65 - 1.43 = 1.22 \text{ kJ}$$

which is identical to the result obtained before.

8-116 A heat engine operates between two constant-pressure cylinders filled with air at different temperatures. The maximum work that can be produced and the final temperatures of the cylinders are to be determined.

Assumptions Air is an ideal gas with constant specific heats at room temperature.

Properties The gas constant of air is $0.287 \text{ kPa}\cdot\text{m}^3/\text{kg}\cdot\text{K}$ (Table A-1). The constant pressure specific heat of air at room temperature is $c_p = 1.005 \text{ kJ/kg}\cdot\text{K}$ (Table A-2).

Analysis For maximum power production, the entropy generation must be zero. We take the two cylinders (the heat source and heat sink) and the heat engine as the system. Noting that the system involves no heat and mass transfer and that the entropy change for cyclic devices is zero, the entropy balance can be expressed as

$$\underbrace{S_{\text{in}} - S_{\text{out}}}_{\text{Net entropy transfer by heat and mass}} + \underbrace{S_{\text{gen}}}_{\text{Entropy generation}} \stackrel{\approx 0}{=} \underbrace{\Delta S_{\text{system}}}_{\text{Change in entropy}}$$

$$0 + S_{\text{gen}} \stackrel{\approx 0}{=} \Delta S_{\text{cylindersource}} + \Delta S_{\text{cylindersink}} + \Delta S_{\text{heat engine}} \stackrel{\approx 0}{=}$$

$$\Delta S_{\text{cylindersource}} + \Delta S_{\text{cylindersink}} = 0$$

$$\left(mc_p \ln \frac{T_2}{T_1} - mR \ln \frac{P_2}{P_1} \right)_{\text{source}} + 0 + \left(mc_p \ln \frac{T_2}{T_1} - mR \ln \frac{P_2}{P_1} \right)_{\text{sink}} = 0$$

$$\ln \frac{T_2}{T_{1A}} \frac{T_2}{T_{1B}} = 0 \longrightarrow T_2^2 = T_{1A} T_{1B}$$

where T_{1A} and T_{1B} are the initial temperatures of the source and the sink, respectively, and T_2 is the common final temperature. Therefore, the final temperature of the tanks for maximum power production is

$$T_2 = \sqrt{T_{1A} T_{1B}} = \sqrt{(900 \text{ K})(300 \text{ K})} = \mathbf{519.6 \text{ K}}$$

The energy balance $E_{\text{in}} - E_{\text{out}} = \Delta E_{\text{system}}$ for the source and sink can be expressed as follows:

Source:

$$-Q_{\text{source,out}} + W_{b,\text{in}} = \Delta U \rightarrow Q_{\text{source,out}} = \Delta H = mc_p (T_{1A} - T_2)$$

$$Q_{\text{source,out}} = mc_p (T_{1A} - T_2) = (30 \text{ kg})(1.005 \text{ kJ/kg}\cdot\text{K})(900 - 519.6)\text{K} = 11,469 \text{ kJ}$$

Sink:

$$Q_{\text{sink,in}} - W_{b,\text{out}} = \Delta U \rightarrow Q_{\text{sink,in}} = \Delta H = mc_p (T_2 - T_{1A})$$

$$Q_{\text{sink,in}} = mc_p (T_2 - T_{1B}) = (30 \text{ kg})(1.005 \text{ kJ/kg}\cdot\text{K})(519.6 - 300)\text{K} = 6621 \text{ kJ}$$

Then the work produced becomes

$$W_{\text{max,out}} = Q_H - Q_L = Q_{\text{source,out}} - Q_{\text{sink,in}} = 11,469 - 6621 = \mathbf{4847 \text{ kJ}}$$

Therefore, a maximum of 4847 kJ of work can be produced during this process

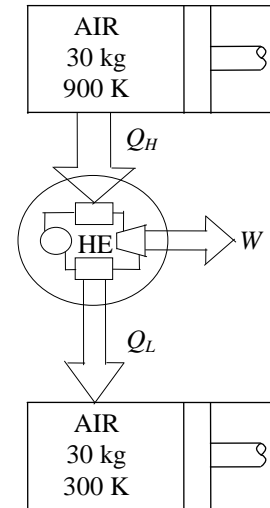

8-117 A heat engine operates between a nitrogen tank and an argon cylinder at different temperatures. The maximum work that can be produced and the final temperatures are to be determined.

Assumptions Nitrogen and argon are ideal gases with constant specific heats at room temperature.

Properties The constant volume specific heat of nitrogen at room temperature is $c_v = 0.743 \text{ kJ/kg}\cdot\text{K}$. The constant pressure specific heat of argon at room temperature is $c_p = 0.5203 \text{ kJ/kg}\cdot\text{K}$ (Table A-2).

Analysis For maximum power production, the entropy generation must be zero. We take the tank, the cylinder (the heat source and the heat sink) and the heat engine as the system. Noting that the system involves no heat and mass transfer and that the entropy change for cyclic devices is zero, the entropy balance can be expressed as

$$\underbrace{S_{\text{in}} - S_{\text{out}}}_{\substack{\text{Net entropy transfer} \\ \text{by heat and mass}}} + \underbrace{S_{\text{gen}}^{\nearrow 0}}_{\substack{\text{Entropy} \\ \text{generation}}} = \underbrace{\Delta S_{\text{system}}}_{\substack{\text{Change} \\ \text{in entropy}}}$$

$$0 + S_{\text{gen}}^{\nearrow 0} = \Delta S_{\text{tank,source}} + \Delta S_{\text{cylinder,sink}} + \Delta S_{\text{heat engine}}^{\nearrow 0}$$

$$(\Delta S)_{\text{source}} + (\Delta S)_{\text{sink}} = 0$$

$$\left(mc_v \ln \frac{T_2}{T_1} - mR \ln \frac{V_2}{V_1} \right)_{\text{source}} + 0 + \left(mc_p \ln \frac{T_2}{T_1} - mR \ln \frac{P_2}{P_1} \right)_{\text{sink}} = 0$$

Substituting,

$$(30 \text{ kg})(0.743 \text{ kJ/kg}\cdot\text{K}) \ln \frac{T_2}{900 \text{ K}} + (15 \text{ kg})(0.5203 \text{ kJ/kg}\cdot\text{K}) \ln \frac{T_2}{300 \text{ K}} = 0$$

Solving for T_2 yields

$$T_2 = \mathbf{676.9 \text{ K}}$$

where T_2 is the common final temperature of the tanks for maximum power production.

The energy balance $E_{\text{in}} - E_{\text{out}} = \Delta E_{\text{system}}$ for the source and sink can be expressed as follows:

Source:

$$-Q_{\text{source,out}} = \Delta U = mc_v(T_2 - T_{1A}) \rightarrow Q_{\text{source,out}} = mc_v(T_{1A} - T_2)$$

$$Q_{\text{source,out}} = mc_v(T_{1A} - T_2) = (30 \text{ kg})(0.743 \text{ kJ/kg}\cdot\text{K})(900 - 676.9)\text{K} = 4973 \text{ kJ}$$

Sink:

$$Q_{\text{sink,in}} - W_{\text{b,out}} = \Delta U \rightarrow Q_{\text{sink,in}} = \Delta H = mc_p(T_2 - T_{1A})$$

$$Q_{\text{sink,in}} = mc_p(T_2 - T_{1A}) = (15 \text{ kg})(0.5203 \text{ kJ/kg}\cdot\text{K})(676.9 - 300)\text{K} = 2941 \text{ kJ}$$

Then the work produced becomes

$$W_{\text{max,out}} = Q_H - Q_L = Q_{\text{source,out}} - Q_{\text{sink,in}} = 4973 - 2941 = \mathbf{2032 \text{ kJ}}$$

Therefore, a maximum of 2032 kJ of work can be produced during this process.

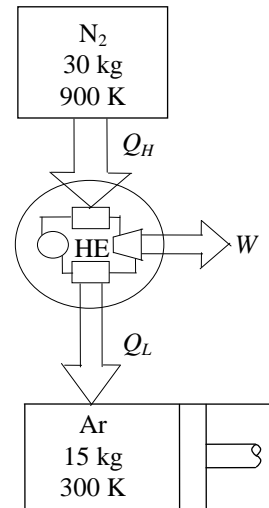

8-118 A rigid tank containing nitrogen is considered. Nitrogen is allowed to escape until the mass of nitrogen becomes one-half of its initial mass. The change in the nitrogen's work potential is to be determined.

Assumptions 1 This is an unsteady process since the conditions within the device are changing during the process. **2** Kinetic and potential energies are negligible. **3** There are no work interactions involved. **4** Nitrogen is an ideal gas with constant specific heats.

Properties The properties of nitrogen at room temperature are $c_p = 1.039$ kJ/kg·K, $c_v = 0.743$ kJ/kg·K, $k = 1.4$, and $R = 0.2968$ kJ/kg·K (Table A-2a).

Analysis The initial and final masses in the tank are

$$m_1 = \frac{P_1 V}{RT_1} = \frac{(1000 \text{ kPa})(0.100 \text{ m}^3)}{(0.2968 \text{ kPa} \cdot \text{m}^3/\text{kg} \cdot \text{K})(293 \text{ K})} = 1.150 \text{ kg}$$

$$m_2 = m_e = \frac{m_1}{2} = \frac{1.150 \text{ kg}}{2} = 0.575 \text{ kg}$$

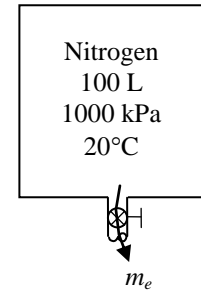

We take the tank as the system, which is a control volume since mass crosses the boundary. Noting that the microscopic energies of flowing and nonflowing fluids are represented by enthalpy h and internal energy u , respectively, the mass and energy balances for this uniform-flow system can be expressed as

Mass balance:

$$m_{\text{in}} - m_{\text{out}} = \Delta m_{\text{system}} \rightarrow m_e = m_2$$

Energy balance:

$$\underbrace{E_{\text{in}} - E_{\text{out}}}_{\substack{\text{Net energy transfer} \\ \text{by heat, work, and mass}}} = \underbrace{\Delta E_{\text{system}}}_{\substack{\text{Change in internal, kinetic,} \\ \text{potential, etc. energies}}}$$

$$-m_e h_e = m_2 u_2 - m_1 u_1$$

Using the average of the initial and final temperatures for the exiting nitrogen, this energy balance equation becomes

$$\begin{aligned} -m_e h_e &= m_2 u_2 - m_1 u_1 \\ -m_e c_p T_e &= m_2 c_v T_2 - m_1 c_v T_1 \\ -(0.575)(1.039)(0.5)(293 + T_2) &= (0.575)(0.743)T_2 - (1.150)(0.743)(293) \end{aligned}$$

Solving for the final temperature, we get

$$T_2 = 224.3 \text{ K}$$

The final pressure in the tank is

$$P_2 = \frac{m_2 R T_2}{V} = \frac{(0.575 \text{ kg})(0.2968 \text{ kPa} \cdot \text{m}^3/\text{kg} \cdot \text{K})(224.3 \text{ K})}{0.100 \text{ m}^3} = 382.8 \text{ kPa}$$

The average temperature and pressure for the exiting nitrogen is

$$T_e = 0.5(T_1 + T_2) = 0.5(293 + 224.3) = 258.7 \text{ K}$$

$$P_e = 0.5(P_1 + P_2) = 0.5(1000 + 382.8) = 691.4 \text{ kPa}$$

The work potential associated with this process is equal to the exergy destroyed during the process. The exergy destruction during a process can be determined from an exergy balance or directly from its definition $X_{\text{destroyed}} = T_0 S_{\text{gen}}$. The entropy generation S_{gen} in this case is determined from an entropy balance on the system:

$$\underbrace{S_{\text{in}} - S_{\text{out}}}_{\substack{\text{Net entropy transfer} \\ \text{by heat and mass}}} + \underbrace{S_{\text{gen}}}_{\substack{\text{Entropy} \\ \text{generation}}} = \underbrace{\Delta S_{\text{system}}}_{\substack{\text{Change} \\ \text{in entropy}}}$$

$$\begin{aligned} -m_e s_e + S_{\text{gen}} &= \Delta S_{\text{tank}} = m_2 s_2 - m_1 s_1 \\ S_{\text{gen}} &= m_2 s_2 - m_1 s_1 + m_e s_e \end{aligned}$$

Rearranging and substituting gives

$$\begin{aligned}
 S_{\text{gen}} &= m_2 s_2 - m_1 s_1 + m_e s_e \\
 &= m_2 (c_p \ln T_2 - R \ln P_2) - m_1 (c_p \ln T_1 - R \ln P_1) + m_e (c_p \ln T_e - R \ln P_e) \\
 &= (0.575) [1.039 \ln(224.3) - (0.2968) \ln(382.8)] - (1.15) [1.039 \ln(293) - (0.2968) \ln(1000)] \\
 &\quad + (0.575) [1.039 \ln(258.7) - (0.2968) \ln(691.4)] \\
 &= 2.2188 - 4.4292 + 2.2032 = -0.007152 \text{ kJ/K}
 \end{aligned}$$

Then,

$$W_{\text{rev}} = X_{\text{destroyed}} = T_0 S_{\text{gen}} = (293 \text{ K})(-0.007152 \text{ kJ/K}) = \mathbf{-2.10 \text{ kJ}}$$

The entropy generation cannot be negative for a thermodynamically possible process. This result is probably due to using average temperature and pressure values for the exiting gas and using constant specific heats for nitrogen. This sensitivity occurs because the entropy generation is very small in this process.

Alternative More Accurate Solution

This problem may also be solved by considering the variation of gas temperature and pressure at the outlet of the tank. The mass balance in this case is

$$\dot{m}_e = -\frac{dm}{dt}$$

which when combined with the reduced first law gives

$$\frac{d(mu)}{dt} = h \frac{dm}{dt}$$

Using the specific heats and the ideal gas equation of state reduces this to

$$c_v \frac{V dP}{R dt} = c_p T \frac{dm}{dt}$$

which upon rearrangement and an additional use of ideal gas equation of state becomes

$$\frac{1}{P} \frac{dP}{dt} = \frac{c_p}{c_v} \frac{1}{m} \frac{dm}{dt}$$

When this is integrated, the result is

$$P_2 = P_1 \left(\frac{m_2}{m_1} \right)^k = 1000 \left(\frac{1}{2} \right)^{1.4} = 378.9 \text{ kPa}$$

The final temperature is then

$$T_2 = \frac{P_2 V}{m_2 R} = \frac{(378.9 \text{ kPa})(0.100 \text{ m}^3)}{(0.575 \text{ kg})(0.2968 \text{ kPa} \cdot \text{m}^3/\text{kg} \cdot \text{K})} = 222.0 \text{ K}$$

The process is then one of

$$\frac{m^k}{P} = \text{const} \quad \text{or} \quad \frac{m^{k-1}}{T} = \text{const}$$

The reduced combined first and second law becomes

$$\dot{W}_{\text{rev}} = -\frac{d(U - T_0 S)}{dt} + (h - T_0 s) \frac{dm}{dt}$$

when the mass balance is substituted and the entropy generation is set to zero (for maximum work production). Replacing the enthalpy term with the first law result and canceling the common dU/dt term reduces this to

$$\dot{W}_{\text{rev}} = T_0 \frac{d(ms)}{dt} - T_0 s \frac{dm}{dt}$$

Expanding the first derivative and canceling the common terms further reduces this to

$$\dot{W}_{\text{rev}} = T_0 m \frac{ds}{dt}$$

Letting $a = P_1 / m_1^k$ and $b = T_1 / m_1^{k-1}$, the pressure and temperature of the nitrogen in the system are related to the mass by

$$P = am^k \quad \text{and} \quad T = bm^{k-1}$$

according to the first law. Then,

$$dP = akm^{k-1} dm \quad \text{and} \quad dT = b(k-1)m^{k-2} dm$$

The entropy change relation then becomes

$$ds = c_p \frac{dT}{T} - R \frac{dP}{P} = [(k-1)c_p - Rk] \frac{dm}{m}$$

Now, multiplying the combined first and second laws by dt and integrating the result gives

$$\begin{aligned} W_{\text{rev}} &= T_0 \int_1^2 m ds = T_0 \int_1^2 m ds [(k-1)c_p - Rk] dm \\ &= T_0 [(k-1)c_p - Rk] (m_2 - m_1) \\ &= (293)[(1.4-1)(1.039) - (0.2968)(1.4)](0.575 - 1.15) \\ &= \mathbf{-0.0135kJ} \end{aligned}$$

Once again the entropy generation is negative, which cannot be the case for a thermodynamically possible process. This is probably due to using constant specific heats for nitrogen. This sensitivity occurs because the entropy generation is very small in this process.

8-119 A pressure cooker is initially half-filled with liquid water. It is kept on the heater for 30 min. The amount water that remained in the cooker and the exergy destroyed are to be determined.

Assumptions 1 This is an unsteady process since the conditions within the device are changing during the process, but it can be analyzed as a uniform-flow process since the state of water vapor leaving the cooker remains constant. **2** Kinetic and potential energies are negligible. **3** Heat loss from the cooker is negligible.

Properties The properties of water are (Tables A-4 through A-6)

$$P_1 = 175 \text{ kPa} \rightarrow \nu_f = 0.001057 \text{ m}^3/\text{kg}, \nu_g = 1.0037 \text{ m}^3/\text{kg}$$

$$u_f = 486.82 \text{ kJ/kg}, u_g = 2524.5 \text{ kJ/kg}$$

$$s_f = 1.4850 \text{ kJ/kg}\cdot\text{K}, s_g = 7.1716 \text{ kJ/kg}\cdot\text{K}$$

$$P_e = 175 \text{ kPa} \left\{ \begin{array}{l} h_e = h_g @ 175 \text{ kPa} = 2700.2 \text{ kJ/kg} \\ \text{sat. vapor} \quad \left\{ \begin{array}{l} s_e = s_g @ 175 \text{ kPa} = 7.1716 \text{ kJ/kg}\cdot\text{K} \end{array} \right. \end{array} \right.$$

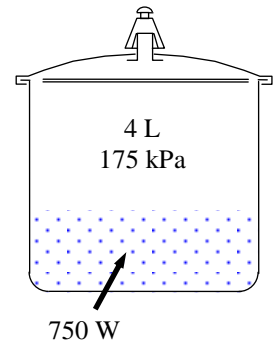

Analysis (a) We take the cooker as the system, which is a control volume since mass crosses the boundary. Noting that the microscopic energies of flowing and nonflowing fluids are represented by enthalpy h and internal energy u , respectively, the mass and energy balances for this uniform-flow system can be expressed as

$$\text{Mass balance:} \quad m_{\text{in}} - m_{\text{out}} = \Delta m_{\text{system}} \rightarrow m_e = m_1 - m_2$$

$$\text{Energy balance:} \quad \underbrace{E_{\text{in}} - E_{\text{out}}}_{\substack{\text{Net energy transfer} \\ \text{by heat, work, and mass}}} = \underbrace{\Delta E_{\text{system}}}_{\substack{\text{Change in internal, kinetic,} \\ \text{potential, etc. energies}}}$$

$$W_{e,\text{in}} - m_e h_e = m_2 u_2 - m_1 u_1 \quad (\text{since } Q \cong \text{ke} \cong \text{pe} \cong 0)$$

The initial mass, initial internal energy, initial entropy, and final mass in the tank are

$$\nu_f = \nu_g = 2 \text{ L} = 0.002 \text{ m}^3$$

$$m_1 = m_f + m_g = \frac{\nu_f}{\nu_f} + \frac{\nu_g}{\nu_g} = \frac{0.002 \text{ m}^3}{0.001057 \text{ m}^3/\text{kg}} + \frac{0.002 \text{ m}^3}{1.0037 \text{ m}^3/\text{kg}} = 1.893 + 0.002 = 1.8945 \text{ kg}$$

$$U_1 = m_1 u_1 = m_f u_f + m_g u_g = 1.893 \times 486.82 + 0.002 \times 2524.5 = 926.6 \text{ kJ}$$

$$S_1 = m_1 s_1 = m_f s_f + m_g s_g = 1.892 \times 1.4850 + 0.002 \times 7.1716 = 2.8239 \text{ kJ/K}$$

$$m_2 = \frac{\nu}{\nu_2} = \frac{0.004 \text{ m}^3}{\nu_2}$$

The amount of electrical energy supplied during this process is

$$W_{e,\text{in}} = \dot{W}_{e,\text{in}} \Delta t = (0.750 \text{ kJ/s})(20 \times 60 \text{ s}) = 900 \text{ kJ}$$

Then from the mass and energy balances,

$$m_e = m_1 - m_2 = 1.894 - \frac{0.004}{\nu_2}$$

$$900 \text{ kJ} = \left(1.894 - \frac{0.004}{\nu_2}\right)(2700.2 \text{ kJ/kg}) + \left(\frac{0.004}{\nu_2}\right)(u_2) - 926.6 \text{ kJ}$$

Substituting $u_2 = u_f + x_2 u_{fg}$ and $\nu_2 = \nu_f + x_2 \nu_{fg}$, and solving for x_2 yields

$$x_2 = 0.001918$$

Thus,

$$\nu_2 = \nu_f + x_2 \nu_{fg} = 0.001057 + 0.001918 \times (1.0037 - 0.001057) = 0.002654 \text{ m}^3 / \text{kg}$$

$$s_2 = s_f + x_2 s_{fg} = 1.4850 + 0.001918 \times 5.6865 = 1.5642 \text{ kJ} / \text{kg} \cdot \text{K}$$

and

$$m_2 = \frac{\mathcal{V}}{\nu_2} = \frac{0.004 \text{ m}^3}{0.002654 \text{ m}^3 / \text{kg}} = \mathbf{1.507 \text{ kg}}$$

(b) The entropy generated during this process is determined by applying the entropy balance on the cooker. Noting that there is no heat transfer and some mass leaves, the entropy balance can be expressed as

$$\underbrace{S_{\text{in}} - S_{\text{out}}}_{\substack{\text{Net entropy transfer} \\ \text{by heat and mass}}} + \underbrace{S_{\text{gen}}}_{\substack{\text{Entropy} \\ \text{generation}}} = \underbrace{\Delta S_{\text{system}}}_{\substack{\text{Change} \\ \text{in entropy}}}$$

$$-m_e s_e + S_{\text{gen}} = \Delta S_{\text{sys}} = m_2 s_2 - m_1 s_1$$

$$S_{\text{gen}} = m_e s_e + m_2 s_2 - m_1 s_1$$

The exergy destroyed during a process can be determined from an exergy balance or directly from its definition $X_{\text{destroyed}} = T_0 S_{\text{gen}}$. Using the S_{gen} relation obtained above and substituting,

$$X_{\text{destroyed}} = T_0 S_{\text{gen}} = T_0 (m_e s_e + m_2 s_2 - m_1 s_1)$$

$$= (298 \text{ K})[(1.894 - 1.507) \times 7.1716 + 1.507 \times 1.5642 - 2.8239]$$

$$= \mathbf{689 \text{ kJ}}$$

8-120 A pressure cooker is initially half-filled with liquid water. Heat is transferred to the cooker for 30 min. The amount of water that remained in the cooker and the exergy destroyed are to be determined.

Assumptions 1 This is an unsteady process since the conditions within the device are changing during the process, but it can be analyzed as a uniform-flow process since the state of water vapor leaving the cooker remains constant. **2** Kinetic and potential energies are negligible. **3** Heat loss from the cooker is negligible.

Properties The properties of water are (Tables A-4 through A-6)

$$P_1 = 175 \text{ kPa} \rightarrow \nu_f = 0.001057 \text{ m}^3/\text{kg}, \nu_g = 1.0037 \text{ m}^3/\text{kg}$$

$$u_f = 486.82 \text{ kJ/kg}, u_g = 2524.5 \text{ kJ/kg}$$

$$s_f = 1.4850 \text{ kJ/kg}\cdot\text{K}, s_g = 7.1716 \text{ kJ/kg}\cdot\text{K}$$

$$P_e = 175 \text{ kPa} \left\{ \begin{array}{l} h_e = h_g @ 175 \text{ kPa} = 2700.2 \text{ kJ/kg} \\ \text{sat. vapor} \quad \left\{ \begin{array}{l} s_e = s_g @ 175 \text{ kPa} = 7.1716 \text{ kJ/kg}\cdot\text{K} \end{array} \right. \end{array} \right.$$

Analysis (a) We take the cooker as the system, which is a control volume since mass crosses the boundary. Noting that the microscopic energies of flowing and nonflowing fluids are represented by enthalpy h and internal energy u , respectively, the mass and energy balances for this uniform-flow system can be expressed as

$$\text{Mass balance:} \quad m_{\text{in}} - m_{\text{out}} = \Delta m_{\text{system}} \rightarrow m_e = m_1 - m_2$$

$$\text{Energy balance:} \quad \underbrace{E_{\text{in}} - E_{\text{out}}}_{\text{Net energy transfer by heat, work, and mass}} = \underbrace{\Delta E_{\text{system}}}_{\text{Change in internal, kinetic, potential, etc. energies}}$$

$$Q_{\text{in}} - m_e h_e = m_2 u_2 - m_1 u_1 \quad (\text{since } W \cong \text{ke} \cong \text{pe} \cong 0)$$

The initial mass, initial internal energy, initial entropy, and final mass in the tank are

$$\nu_f = \nu_g = 2 \text{ L} = 0.002 \text{ m}^3$$

$$m_1 = m_f + m_g = \frac{\nu_f}{\nu_f} + \frac{\nu_g}{\nu_g} = \frac{0.002 \text{ m}^3}{0.001057 \text{ m}^3/\text{kg}} + \frac{0.002 \text{ m}^3}{1.0037 \text{ m}^3/\text{kg}} = 1.893 + 0.002 = 1.8945 \text{ kg}$$

$$U_1 = m_1 u_1 = m_f u_f + m_g u_g = 1.893 \times 486.82 + 0.002 \times 2524.5 = 926.6 \text{ kJ}$$

$$S_1 = m_1 s_1 = m_f s_f + m_g s_g = 1.892 \times 1.4850 + 0.002 \times 7.1716 = 2.8239 \text{ kJ/K}$$

$$m_2 = \frac{\nu}{\nu_2} = \frac{0.004 \text{ m}^3}{\nu_2}$$

The amount of heat transfer during this process is

$$Q = \dot{Q} \Delta t = (0.750 \text{ kJ/s})(20 \times 60 \text{ s}) = 900 \text{ kJ}$$

Then from the mass and energy balances,

$$m_e = m_1 - m_2 = 1.894 - \frac{0.004}{\nu_2}$$

$$900 \text{ kJ} = \left(1.894 - \frac{0.004}{\nu_2}\right)(2700.2 \text{ kJ/kg}) + \left(\frac{0.004}{\nu_2}\right)(u_2) - 926.6 \text{ kJ}$$

Substituting $u_2 = u_f + x_2 u_{fg}$ and $\nu_2 = \nu_f + x_2 \nu_{fg}$, and solving for x_2 yields

$$x_2 = 0.001918$$

Thus,

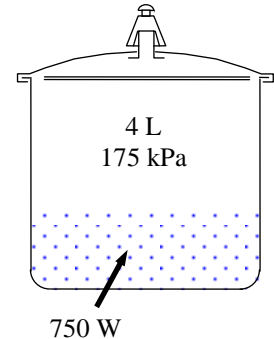

$$v_2 = v_f + x_2 v_{fg} = 0.001057 + 0.001918 \times (1.0037 - 0.001057) = 0.002654 \text{ m}^3 / \text{kg}$$

$$s_2 = s_f + x_2 s_{fg} = 1.4850 + 0.001918 \times 5.6865 = 1.5642 \text{ kJ} / \text{kg} \cdot \text{K}$$

and

$$m_2 = \frac{V}{v_2} = \frac{0.004 \text{ m}^3}{0.002654 \text{ m}^3 / \text{kg}} = \mathbf{1.507 \text{ kg}}$$

(b) The entropy generated during this process is determined by applying the entropy balance on an *extended system* that includes the cooker and its immediate surroundings so that the boundary temperature of the extended system at the location of heat transfer is the heat source temperature, $T_{\text{source}} = 180^\circ\text{C}$ at all times. The entropy balance for it can be expressed as

$$\underbrace{S_{\text{in}} - S_{\text{out}}}_{\substack{\text{Net entropy transfer} \\ \text{by heat and mass}}} + \underbrace{S_{\text{gen}}}_{\substack{\text{Entropy} \\ \text{generation}}} = \underbrace{\Delta S_{\text{system}}}_{\substack{\text{Change} \\ \text{in entropy}}}$$

$$\frac{Q_{\text{in}}}{T_{\text{b,in}}} - m_e s_e + S_{\text{gen}} = \Delta S_{\text{sys}} = m_2 s_2 - m_1 s_1$$

$$S_{\text{gen}} = m_e s_e + m_2 s_2 - m_1 s_1 - \frac{Q_{\text{in}}}{T_{\text{source}}}$$

The exergy destroyed during a process can be determined from an exergy balance or directly from its definition $X_{\text{destroyed}} = T_0 S_{\text{gen}}$. Using the S_{gen} relation obtained above and substituting,

$$X_{\text{destroyed}} = T_0 S_{\text{gen}} = T_0 \left(m_e s_e + m_2 s_2 - m_1 s_1 - \frac{Q_{\text{in}}}{T_{\text{source}}} \right)$$

$$= (298 \text{ K})[(1.894 - 1.507) \times 7.1716 + 1.507 \times 1.5642 - 2.8239 - 900 / 453]$$

$$= \mathbf{96.8 \text{ kJ}}$$

Note that the exergy destroyed is much less when heat is supplied from a heat source rather than an electric resistance heater.

8-121 Steam is condensed by cooling water in the condenser of a power plant. The rate of condensation of steam and the rate of exergy destruction are to be determined.

Assumptions 1 Steady operating conditions exist. 2 The heat exchanger is well-insulated so that heat loss to the surroundings is negligible and thus heat transfer from the hot fluid is equal to the heat transfer to the cold fluid. 3 Changes in the kinetic and potential energies of fluid streams are negligible. 4 Fluid properties are constant.

Properties The enthalpy and entropy of vaporization of water at 50°C are $h_{fg} = 2382.0$ kJ/kg and $s_{fg} = 7.3710$ kJ/kg.K (Table A-4). The specific heat of water at room temperature is $c_p = 4.18$ kJ/kg.°C (Table A-3).

Analysis (a) We take the cold water tubes as the system, which is a control volume. The energy balance for this steady-flow system can be expressed in the rate form as

$$\underbrace{\dot{E}_{in} - \dot{E}_{out}}_{\text{Rate of net energy transfer by heat, work, and mass}} = \underbrace{\Delta \dot{E}_{system}}_{\substack{\text{Rate of change in internal, kinetic,} \\ \text{potential, etc. energies}}} \stackrel{\neq 0 \text{ (steady)}}{=} 0$$

$$\dot{E}_{in} = \dot{E}_{out}$$

$$\dot{Q}_{in} + \dot{m}h_1 = \dot{m}h_2 \quad (\text{since } \Delta ke \cong \Delta pe \cong 0)$$

$$\dot{Q}_{in} = \dot{m}c_p(T_2 - T_1)$$

Then the heat transfer rate to the cooling water in the condenser becomes

$$\begin{aligned} \dot{Q} &= [\dot{m}c_p(T_{out} - T_{in})]_{\text{cooling water}} \\ &= (240 \text{ kg/s})(4.18 \text{ kJ/kg}\cdot\text{°C})(20\text{°C} - 12\text{°C}) \\ &= 8026 \text{ kJ/s} \end{aligned}$$

The rate of condensation of steam is determined to be

$$\dot{Q} = (\dot{m}h_{fg})_{\text{steam}} \longrightarrow \dot{m}_{\text{steam}} = \frac{\dot{Q}}{h_{fg}} = \frac{8026 \text{ kJ/s}}{2382.0 \text{ kJ/kg}} = \mathbf{3.369 \text{ kg/s}}$$

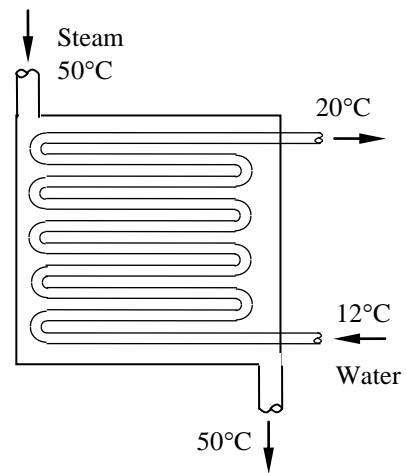

(b) The rate of entropy generation within the condenser during this process can be determined by applying the rate form of the entropy balance on the entire condenser. Noting that the condenser is well-insulated and thus heat transfer is negligible, the entropy balance for this steady-flow system can be expressed as

$$\underbrace{\dot{S}_{in} - \dot{S}_{out}}_{\text{Rate of net entropy transfer by heat and mass}} + \underbrace{\dot{S}_{gen}}_{\text{Rate of entropy generation}} = \underbrace{\Delta \dot{S}_{system}}_{\substack{\neq 0 \text{ (steady)}}} \stackrel{\neq 0 \text{ (steady)}}{=} 0$$

$$\dot{m}_1 s_1 + \dot{m}_3 s_3 - \dot{m}_2 s_2 - \dot{m}_4 s_4 + \dot{S}_{gen} = 0 \quad (\text{since } \dot{Q} = 0)$$

$$\dot{m}_{\text{water}} s_1 + \dot{m}_{\text{steam}} s_3 - \dot{m}_{\text{water}} s_2 - \dot{m}_{\text{steam}} s_4 + \dot{S}_{gen} = 0$$

$$\dot{S}_{gen} = \dot{m}_{\text{water}}(s_2 - s_1) + \dot{m}_{\text{steam}}(s_4 - s_3)$$

Noting that water is an incompressible substance and steam changes from saturated vapor to saturated liquid, the rate of entropy generation is determined to be

$$\begin{aligned} \dot{S}_{gen} &= \dot{m}_{\text{water}} c_p \ln \frac{T_2}{T_1} + \dot{m}_{\text{steam}}(s_f - s_g) = \dot{m}_{\text{water}} c_p \ln \frac{T_2}{T_1} - \dot{m}_{\text{steam}} s_{fg} \\ &= (240 \text{ kg/s})(4.18 \text{ kJ/kg}\cdot\text{K}) \ln \frac{20 + 273}{12 + 273} - (3.369 \text{ kg/s})(7.3710 \text{ kJ/kg}\cdot\text{K}) \\ &= 2.937 \text{ kW/K} \end{aligned}$$

Then the exergy destroyed can be determined directly from its definition $X_{\text{destroyed}} = T_0 \dot{S}_{gen}$ to be

$$\dot{X}_{\text{destroyed}} = T_0 \dot{S}_{gen} = (285 \text{ K})(2.937 \text{ kW/K}) = \mathbf{837 \text{ kW}}$$

8-122 A system consisting of a compressor, a storage tank, and a turbine as shown in the figure is considered. The change in the exergy of the air in the tank and the work required to compress the air as the tank was being filled are to be determined.

Assumptions 1 Changes in the kinetic and potential energies are negligible. **4** Air is an ideal gas with constant specific heats.

Properties The properties of air at room temperature are $R = 0.287 \text{ kPa}\cdot\text{m}^3/\text{kg}\cdot\text{K}$, $c_p = 1.005 \text{ kJ}/\text{kg}\cdot\text{K}$, $c_v = 0.718 \text{ kJ}/\text{kg}\cdot\text{K}$, $k = 1.4$ (Table A-2a).

Analysis The initial mass of air in the tank is

$$m_{\text{initial}} = \frac{P_{\text{initial}}\mathcal{V}}{RT_{\text{initial}}} = \frac{(100 \text{ kPa})(5 \times 10^5 \text{ m}^3)}{(0.287 \text{ kPa}\cdot\text{m}^3/\text{kg}\cdot\text{K})(293 \text{ K})} = 0.5946 \times 10^6 \text{ kg}$$

and the final mass in the tank is

$$m_{\text{final}} = \frac{P_{\text{final}}\mathcal{V}}{RT_{\text{final}}} = \frac{(600 \text{ kPa})(5 \times 10^5 \text{ m}^3)}{(0.287 \text{ kPa}\cdot\text{m}^3/\text{kg}\cdot\text{K})(293 \text{ K})} = 3.568 \times 10^6 \text{ kg}$$

Since the compressor operates as an isentropic device,

$$T_2 = T_1 \left(\frac{P_2}{P_1} \right)^{(k-1)/k}$$

The conservation of mass applied to the tank gives

$$\frac{dm}{dt} = \dot{m}_{\text{in}}$$

while the first law gives

$$\dot{Q} = \frac{d(mu)}{dt} - h \frac{dm}{dt}$$

Employing the ideal gas equation of state and using constant specific heats, expands this result to

$$\dot{Q} = \frac{\mathcal{V}c_v}{R} \frac{dP}{dt} - c_p T_2 \frac{\mathcal{V}}{RT} \frac{dP}{dt}$$

Using the temperature relation across the compressor and multiplying by dt puts this result in the form

$$\dot{Q}dt = \frac{\mathcal{V}c_v}{R} dP - c_p T_1 \left(\frac{P}{P_1} \right)^{(k-1)/k} \frac{\mathcal{V}}{RT} dP$$

When this integrated, it yields (i and f stand for initial and final states)

$$\begin{aligned} Q &= \frac{\mathcal{V}c_v}{R} (P_f - P_i) - \frac{k}{2k-1} \frac{c_p \mathcal{V}}{R} \left[P_f \left(\frac{P_f}{P_i} \right)^{(k-1)/k} - P_i \right] \\ &= \frac{(5 \times 10^5)(0.718)}{0.287} (600 - 100) - \frac{1.4}{2(1.4) - 1} \frac{(1.005)(5 \times 10^5)}{0.287} \left[600 \left(\frac{600}{100} \right)^{0.4/1.4} - 100 \right] \\ &= -6.017 \times 10^8 \text{ kJ} \end{aligned}$$

The negative result show that heat is transferred from the tank. Applying the first law to the tank and compressor gives

$$(\dot{Q} - \dot{W}_{\text{out}})dt = d(mu) - h_1 dm$$

which integrates to

$$Q - W_{\text{out}} = (m_f u_f - m_i u_i) - h_1 (m_f - m_i)$$

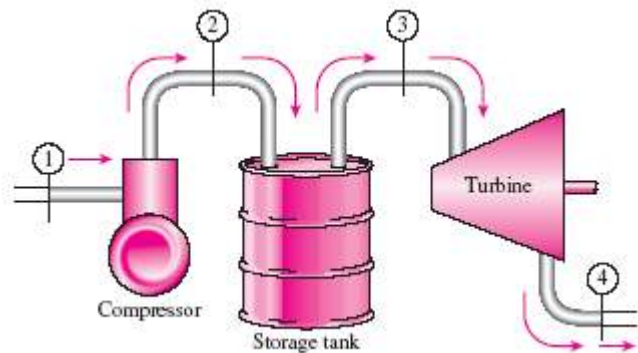

Upon rearrangement,

$$\begin{aligned} W_{\text{out}} &= Q + (c_p - c_v)T(m_f - m_i) \\ &= -6.017 \times 10^8 + (1.005 - 0.718)(293)[(3.568 - 0.5946) \times 10^6] \\ &= \mathbf{-3.516 \times 10^8 \text{ kJ}} \end{aligned}$$

The negative sign shows that work is done on the compressor. When the combined first and second laws is reduced to fit the compressor and tank system and the mass balance incorporated, the result is

$$\dot{W}_{\text{rev}} = \dot{Q} \left(1 - \frac{T_0}{T_R} \right) - \frac{d(U - T_0 S)}{dt} + (h - T_0 s) \frac{dm}{dt}$$

which when integrated over the process becomes

$$\begin{aligned} W_{\text{rev}} &= Q \left(1 - \frac{T_0}{T_R} \right) + m_i [(u_i - h_1) - T_0 (s_i - s_1)] - m_f [(u_f - h_1) - T_0 (s_f - s_1)] \\ &= Q \left(1 - \frac{T_0}{T_R} \right) + m_i [T_i (c_v - c_p)] - m_f \left[T_f (c_v - c_p) - T_0 R \ln \left(\frac{P_f}{P_i} \right) \right] \\ &= -6.017 \times 10^8 \left(1 - \frac{293}{293} \right) + 0.5946 \times 10^6 [(0.718 - 1.005)293] \\ &\quad - 3.568 \times 10^6 \left[(0.718 - 1.005)293 + 293(0.287) \ln \frac{600}{100} \right] \\ &= \mathbf{7.875 \times 10^8 \text{ kJ}} \end{aligned}$$

This is the exergy change of the air stored in the tank.

8-123 The air stored in the tank of the system shown in the figure is released through the isentropic turbine. The work produced and the change in the exergy of the air in the tank are to be determined.

Assumptions 1 Changes in the kinetic and potential energies are negligible. **4** Air is an ideal gas with constant specific heats.

Properties The properties of air at room temperature are $R = 0.287 \text{ kPa}\cdot\text{m}^3/\text{kg}\cdot\text{K}$, $c_p = 1.005 \text{ kJ/kg}\cdot\text{K}$, $c_v = 0.718 \text{ kJ/kg}\cdot\text{K}$, $k = 1.4$ (Table A-2a).

Analysis The initial mass of air in the tank is

$$m_{\text{initial}} = \frac{P_{\text{initial}}\mathcal{V}}{RT_{\text{initial}}} = \frac{(600 \text{ kPa})(5 \times 10^5 \text{ m}^3)}{(0.287 \text{ kPa}\cdot\text{m}^3/\text{kg}\cdot\text{K})(293 \text{ K})} = 3.568 \times 10^6 \text{ kg}$$

and the final mass in the tank is

$$m_{\text{final}} = \frac{P_{\text{final}}\mathcal{V}}{RT_{\text{final}}} = \frac{(100 \text{ kPa})(5 \times 10^5 \text{ m}^3)}{(0.287 \text{ kPa}\cdot\text{m}^3/\text{kg}\cdot\text{K})(293 \text{ K})} = 0.5946 \times 10^6 \text{ kg}$$

The conservation of mass is

$$\frac{dm}{dt} = \dot{m}_{\text{in}}$$

while the first law gives

$$\dot{Q} = \frac{d(mu)}{dt} - h \frac{dm}{dt}$$

Employing the ideal gas equation of state and using constant specific heats, expands this result to

$$\begin{aligned} \dot{Q} &= \frac{\mathcal{V}c_v}{R} \frac{dP}{dt} - c_p T \frac{\mathcal{V}}{RT} \frac{dP}{dt} \\ &= \frac{c_v - c_p}{R} \mathcal{V} \frac{dP}{dt} \\ &= -\mathcal{V} \frac{dP}{dt} \end{aligned}$$

When this is integrated over the process, the result is (i and f stand for initial and final states)

$$Q = -\mathcal{V}(P_f - P_i) = -5 \times 10^5 (100 - 600) = 2.5 \times 10^8 \text{ kJ}$$

Applying the first law to the tank and compressor gives

$$(\dot{Q} - \dot{W}_{\text{out}})dt = d(mu) - hdm$$

which integrates to

$$\begin{aligned} Q - W_{\text{out}} &= (m_f u_f - m_i u_i) + h(m_i - m_f) \\ -W_{\text{out}} &= -Q + m_f u_f - m_i u_i + h(m_i - m_f) \\ W_{\text{out}} &= Q - m_f u_f + m_i u_i - h(m_i - m_f) \\ &= Q - m_f c_v T + m_i c_p T - c_p T(m_i - m_f) \\ &= 2.5 \times 10^8 - (0.5946 \times 10^6)(0.718)(293) + (3.568 \times 10^6)(1.005)(293) \\ &\quad - (1.005)(293)(3.568 \times 10^6 - 0.5946 \times 10^6) \\ &= \mathbf{3.00 \times 10^8 \text{ kJ}} \end{aligned}$$

This is the work output from the turbine. When the combined first and second laws is reduced to fit the turbine and tank system and the mass balance incorporated, the result is

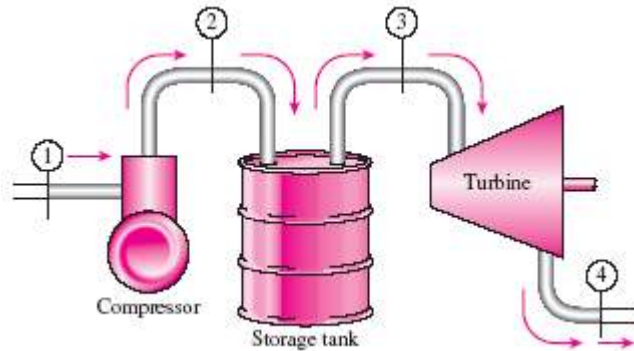

$$\begin{aligned}
\dot{W}_{\text{rev}} &= \dot{Q} \left(1 - \frac{T_0}{T_R} \right) - \frac{d(U - T_0 S)}{dt} + (h - T_0 s) \frac{dm}{dt} \\
&= \dot{Q} \left(1 - \frac{T_0}{T_R} \right) - (u - T_0 s) \frac{dm}{dt} - m \frac{d(u - T_0 s)}{dt} + (h - T_0 s) \frac{dm}{dt} \\
&= \dot{Q} \left(1 - \frac{T_0}{T_R} \right) + (c_p - c_v) T \frac{dm}{dt} + m T_0 \frac{ds}{dt} \\
&= \dot{Q} \left(1 - \frac{T_0}{T_R} \right) + (c_p - c_v) T \frac{dm}{dt} + \nu \frac{T_0}{T} (P_f - P_i)
\end{aligned}$$

where the last step uses entropy change equation. When this is integrated over the process it becomes

$$\begin{aligned}
W_{\text{rev}} &= Q \left(1 - \frac{T_0}{T_R} \right) + (c_p - c_v) T (m_f - m_i) + \nu \frac{T_0}{T} (P_f - P_i) \\
&= 3.00 \times 10^8 \left(1 - \frac{293}{293} \right) + (1.005 - 0.718)(293)(0.5946 - 3.568) \times 10^6 + 5 \times 10^5 \frac{293}{293} (100 - 600) \\
&= 0 - 2.500 \times 10^8 - 2.5 \times 10^8 \\
&= \mathbf{-5.00 \times 10^8 \text{ kJ}}
\end{aligned}$$

This is the exergy change of the air in the storage tank.

8-124 A heat engine operates between a tank and a cylinder filled with air at different temperatures. The maximum work that can be produced and the final temperatures are to be determined.

Assumptions Air is an ideal gas with constant specific heats at room temperature.

Properties The specific heats of air are $c_v = 0.718 \text{ kJ/kg}\cdot\text{K}$ and $c_p = 1.005 \text{ kJ/kg}\cdot\text{K}$ (Table A-2).

Analysis For maximum power production, the entropy generation must be zero. We take the tank, the cylinder (the heat source and the heat sink) and the heat engine as the system. Noting that the system involves no heat and mass transfer and that the entropy change for cyclic devices is zero, the entropy balance can be expressed as

$$\underbrace{S_{\text{in}} - S_{\text{out}}}_{\text{Net entropy transfer by heat and mass}} + \underbrace{S_{\text{gen}}}_{\text{Entropy generation}} \stackrel{\approx 0}{=} \underbrace{\Delta S_{\text{system}}}_{\text{Change in entropy}}$$

$$0 + S_{\text{gen}} \stackrel{\approx 0}{=} \Delta S_{\text{tank,source}} + \Delta S_{\text{cylinder,sink}} + \Delta S_{\text{heat engine}} \stackrel{\approx 0}{=}$$

$$(\Delta S)_{\text{source}} + (\Delta S)_{\text{sink}} = 0$$

$$\left(mc_v \ln \frac{T_2}{T_1} - mR \ln \frac{V_2}{V_1} \right)_{\text{source}} + 0 + \left(mc_p \ln \frac{T_2}{T_1} - mR \ln \frac{P_2}{P_1} \right)_{\text{sink}} = 0$$

$$\ln \frac{T_2}{T_{1A}} + \frac{c_p}{c_v} \ln \frac{T_2}{T_{1B}} = 0 \longrightarrow \frac{T_2}{T_{1A}} \left(\frac{T_2}{T_{1B}} \right)^k = 1 \longrightarrow T_2 = (T_{1A} T_{1B}^k)^{1/(k+1)}$$

where T_{1A} and T_{1B} are the initial temperatures of the source and the sink, respectively, and T_2 is the common final temperature. Therefore, the final temperature of the tanks for maximum power production is

$$T_2 = \left((600 \text{ K})(280 \text{ K})^{1.4} \right)^{\frac{1}{2.4}} = \mathbf{384.7 \text{ K}}$$

Source:

$$-Q_{\text{source,out}} = \Delta U = mc_v(T_2 - T_{1A}) \rightarrow Q_{\text{source,out}} = mc_v(T_{1A} - T_2)$$

$$Q_{\text{source,out}} = mc_v(T_{1A} - T_2) = (40 \text{ kg})(0.718 \text{ kJ/kg}\cdot\text{K})(600 - 384.7)\text{K} = 6184 \text{ kJ}$$

Sink:

$$Q_{\text{sink,in}} - W_{\text{b,out}} = \Delta U \rightarrow Q_{\text{sink,in}} = \Delta H = mc_p(T_2 - T_{1A})$$

$$Q_{\text{sink,in}} = mc_p(T_2 - T_{1A}) = (40 \text{ kg})(1.005 \text{ kJ/kg}\cdot\text{K})(384.7 - 280)\text{K} = 4208 \text{ kJ}$$

Then the work produced becomes

$$W_{\text{max,out}} = Q_H - Q_L = Q_{\text{source,out}} - Q_{\text{sink,in}} = 6184 - 4208 = \mathbf{1977 \text{ kJ}}$$

Therefore, a maximum of 1977 kJ of work can be produced during this process.

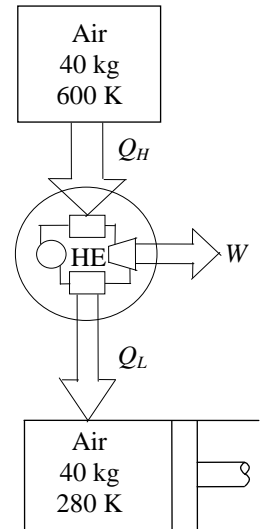

8-125E Large brass plates are heated in an oven at a rate of 175/min. The rate of heat transfer to the plates in the oven and the rate of exergy destruction associated with this heat transfer process are to be determined.

Assumptions 1 The thermal properties of the plates are constant. 2 The changes in kinetic and potential energies are negligible. 3 The environment temperature is 75°F.

Properties The density and specific heat of the brass are given to be $\rho = 532.5 \text{ lbm/ft}^3$ and $c_p = 0.091 \text{ Btu/lbm}\cdot\text{°F}$.

Analysis We take the plate to be the system. The energy balance for this closed system can be expressed as

$$\underbrace{E_{\text{in}} - E_{\text{out}}}_{\substack{\text{Net energy transfer} \\ \text{by heat, work, and mass}}} = \underbrace{\Delta E_{\text{system}}}_{\substack{\text{Change in internal, kinetic,} \\ \text{potential, etc. energies}}} \\ Q_{\text{in}} = \Delta U_{\text{plate}} = m(u_2 - u_1) = mc(T_2 - T_1)$$

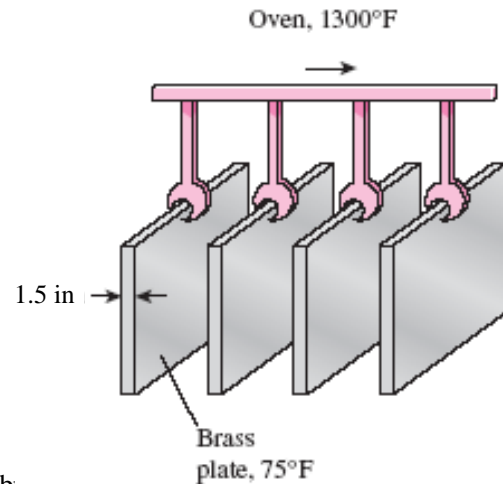

The mass of each plate and the amount of heat transfer to each plate is

$$m = \rho V = \rho LA = (532.5 \text{ lbm/ft}^3)[(1.5/12 \text{ ft})(1 \text{ ft})(3 \text{ ft})] = 199.7 \text{ lb}$$

$$Q_{\text{in}} = mc(T_2 - T_1) = (199.7 \text{ lbm/plate})(0.091 \text{ Btu/lbm}\cdot\text{°F})(1000 - 75)\text{°F} = 16,809 \text{ Btu/plate}$$

Then the total rate of heat transfer to the plates becomes

$$\dot{Q}_{\text{total}} = \dot{n}_{\text{plate}} Q_{\text{in, per plate}} = (175 \text{ plates/min}) \times (16,809 \text{ Btu/plate}) = 2,941,575 \text{ Btu/min} = \mathbf{49,025 \text{ Btu/s}}$$

We again take a single plate as the system. The entropy generated during this process can be determined by applying an entropy balance on an *extended system* that includes the plate and its immediate surroundings so that the boundary temperature of the extended system is at 1300°F at all times:

$$\underbrace{S_{\text{in}} - S_{\text{out}}}_{\substack{\text{Net entropy transfer} \\ \text{by heat and mass}}} + \underbrace{S_{\text{gen}}}_{\substack{\text{Entropy} \\ \text{generation}}} = \underbrace{\Delta S_{\text{system}}}_{\substack{\text{Change} \\ \text{in entropy}}} \\ \frac{Q_{\text{in}}}{T_b} + S_{\text{gen}} = \Delta S_{\text{system}} \rightarrow S_{\text{gen}} = -\frac{Q_{\text{in}}}{T_b} + \Delta S_{\text{system}}$$

where

$$\Delta S_{\text{system}} = m(s_2 - s_1) = mc_{\text{avg}} \ln \frac{T_2}{T_1} = (199.7 \text{ lbm})(0.091 \text{ Btu/lbm}\cdot\text{R}) \ln \frac{(1000 + 460) \text{ R}}{(75 + 460) \text{ R}} = 18.24 \text{ Btu/R}$$

Substituting,

$$S_{\text{gen}} = -\frac{Q_{\text{in}}}{T_b} + \Delta S_{\text{system}} = -\frac{16,809 \text{ Btu}}{1300 + 460 \text{ R}} + 18.24 \text{ Btu/R} = 8.692 \text{ Btu/R (per plate)}$$

Then the rate of entropy generation becomes

$$\dot{S}_{\text{gen}} = S_{\text{gen}} \dot{n}_{\text{plate}} = (8.692 \text{ Btu/R} \cdot \text{plate})(175 \text{ plates/min}) = 1521 \text{ Btu/min}\cdot\text{R} = 25.35 \text{ Btu/s}\cdot\text{R}$$

The exergy destroyed during a process can be determined from an exergy balance or directly from its definition $X_{\text{destroyed}} = T_0 S_{\text{gen}}$,

$$\dot{X}_{\text{destroyed}} = T_0 \dot{S}_{\text{gen}} = (535 \text{ R})(25.35 \text{ Btu/s}\cdot\text{R}) = \mathbf{13,560 \text{ Btu/s}}$$

8-126 A regenerator is considered to save heat during the cooling of milk in a dairy plant. The amounts of fuel and money such a generator will save per year and the rate of exergy destruction within the regenerator are to be determined.

Assumptions 1 Steady operating conditions exist. 2 The properties of the milk are constant. 5 The environment temperature is 18°C.

Properties The average density and specific heat of milk can be taken to be $\rho_{\text{milk}} \cong \rho_{\text{water}} = 1 \text{ kg/L}$ and $c_{p,\text{milk}} = 3.79 \text{ kJ/kg}\cdot^\circ\text{C}$ (Table A-3).

Analysis The mass flow rate of the milk is

$$\dot{m}_{\text{milk}} = \rho \dot{V}_{\text{milk}} = (1 \text{ kg/L})(12 \text{ L/s}) = 12 \text{ kg/s} = 43,200 \text{ kg/h}$$

Taking the pasteurizing section as the system, the energy balance for this steady-flow system can be expressed in the rate form as

$$\underbrace{\dot{E}_{\text{in}} - \dot{E}_{\text{out}}}_{\text{Rate of net energy transfer by heat, work, and mass}} = \underbrace{\Delta \dot{E}_{\text{system}}}_{\text{Rate of change in internal, kinetic, potential, etc. energies}} \stackrel{\text{no (steady)}}{=} 0 \rightarrow \dot{E}_{\text{in}} = \dot{E}_{\text{out}}$$

$$\dot{Q}_{\text{in}} + \dot{m}h_1 = \dot{m}h_2 \quad (\text{since } \Delta ke \cong \Delta pe \cong 0)$$

$$\dot{Q}_{\text{in}} = \dot{m}_{\text{milk}} c_p (T_2 - T_1)$$

Therefore, to heat the milk from 4 to 72°C as being done currently, heat must be transferred to the milk at a rate of

$$\dot{Q}_{\text{current}} = [\dot{m}c_p (T_{\text{pasteurization}} - T_{\text{refrigeration}})]_{\text{milk}} = (12 \text{ kg/s})(3.79 \text{ kJ/kg}\cdot^\circ\text{C})(72 - 4)^\circ\text{C} = 3093 \text{ kJ/s}$$

The proposed regenerator has an effectiveness of $\varepsilon = 0.82$, and thus it will save 82 percent of this energy. Therefore,

$$\dot{Q}_{\text{saved}} = \varepsilon \dot{Q}_{\text{current}} = (0.82)(3093 \text{ kJ/s}) = 2536 \text{ kJ/s}$$

Noting that the boiler has an efficiency of $\eta_{\text{boiler}} = 0.82$, the energy savings above correspond to fuel savings of

$$\text{Fuel Saved} = \frac{\dot{Q}_{\text{saved}}}{\eta_{\text{boiler}}} = \frac{(2536 \text{ kJ/s})}{(0.82)} \frac{(1 \text{ therm})}{(105,500 \text{ kJ})} = 0.02931 \text{ therm/s}$$

Noting that 1 year = 365×24=8760 h and unit cost of natural gas is \$1.04/therm, the annual fuel and money savings will be

$$\text{Fuel Saved} = (0.02931 \text{ therms/s})(8760 \times 3600 \text{ s}) = \mathbf{924,450 \text{ therms/yr}}$$

$$\text{Money saved} = (\text{Fuel saved})(\text{Unit cost of fuel}) = (924,450 \text{ therm/yr})(\$1.30/\text{therm}) = \mathbf{\$1,201,800\text{yr}}$$

The rate of entropy generation during this process is determined by applying the rate form of the entropy balance on an *extended system* that includes the regenerator and the immediate surroundings so that the boundary temperature is the surroundings temperature, which we take to be the cold water temperature of 18°C.

$$\underbrace{\dot{S}_{\text{in}} - \dot{S}_{\text{out}}}_{\text{Rate of net entropy transfer by heat and mass}} + \underbrace{\dot{S}_{\text{gen}}}_{\text{Rate of entropy generation}} = \underbrace{\Delta \dot{S}_{\text{system}}}_{\text{Rate of change of entropy}} \stackrel{\text{no (steady)}}{=} 0 \rightarrow \dot{S}_{\text{gen}} = \dot{S}_{\text{out}} - \dot{S}_{\text{in}}$$

Disregarding entropy transfer associated with fuel flow, the only significant difference between the two cases is the reduction in the entropy transfer to water due to the reduction in heat transfer to water, and is determined to be

$$\dot{S}_{\text{gen, reduction}} = \dot{S}_{\text{out, reduction}} = \frac{\dot{Q}_{\text{out, reduction}}}{T_{\text{surr}}} = \frac{\dot{Q}_{\text{saved}}}{T_{\text{surr}}} = \frac{2536 \text{ kJ/s}}{18 + 273} = 8.715 \text{ kW/K}$$

$$S_{\text{gen, reduction}} = \dot{S}_{\text{gen, reduction}} \Delta t = (8.715 \text{ kJ/s}\cdot\text{K})(8760 \times 3600 \text{ s/year}) = 2.75 \times 10^8 \text{ kJ/K (per year)}$$

The exergy destroyed during a process can be determined from an exergy balance or directly from its definition $X_{\text{destroyed}} = T_0 S_{\text{gen}}$,

$$X_{\text{destroyed, reduction}} = T_0 S_{\text{gen, reduction}} = (291 \text{ K})(2.75 \times 10^8 \text{ kJ/K}) = \mathbf{8.00 \times 10^{10} \text{ kJ (per year)}}$$

8-127 Exhaust gases are expanded in a turbine, which is not well-insulated. The actual and reversible power outputs, the exergy destroyed, and the second-law efficiency are to be determined.

Assumptions 1 Steady operating conditions exist. 2 Potential energy change is negligible. 3 Air is an ideal gas with constant specific heats.

Properties The gas constant of air is $R = 0.287 \text{ kJ/kg}\cdot\text{K}$ and the specific heat of air at the average temperature of $(627+527)/2 = 577^\circ\text{C} = 850 \text{ K}$ is $c_p = 1.11 \text{ kJ/kg}\cdot^\circ\text{C}$ (Table A-2).

Analysis (a) The enthalpy and entropy changes of air across the turbine are

$$\Delta h = c_p (T_2 - T_1) = (1.11 \text{ kJ/kg}\cdot^\circ\text{C})(527 - 627)^\circ\text{C} = -111 \text{ kJ/kg}$$

$$\begin{aligned} \Delta s &= c_p \ln \frac{T_2}{T_1} - R \ln \frac{P_2}{P_1} \\ &= (1.11 \text{ kJ/kg}\cdot\text{K}) \ln \frac{(527 + 273) \text{ K}}{(627 + 273) \text{ K}} - (0.287 \text{ kJ/kg}\cdot\text{K}) \ln \frac{500 \text{ kPa}}{1200 \text{ kPa}} \\ &= 0.1205 \text{ kJ/kg}\cdot\text{K} \end{aligned}$$

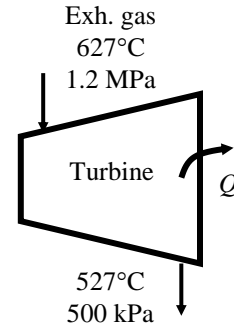

The actual and reversible power outputs from the turbine are

$$-\dot{W}_{a,\text{out}} = \dot{m}\Delta h + \dot{Q}_{\text{out}} = (2.5 \text{ kg/s})(-111 \text{ kJ/kg}) + 20 \text{ kW} = \mathbf{-257.5 \text{ kW}}$$

$$-\dot{W}_{\text{rev},\text{out}} = \dot{m}(\Delta h - T_0 \Delta s) = (2.5 \text{ kg/s})(111 \text{ kJ/kg}) - (25 + 273 \text{ K})(0.1205 \text{ kJ/kg}\cdot\text{K}) = \mathbf{-367.3 \text{ kW}}$$

or

$$\dot{W}_{a,\text{out}} = \mathbf{257.5 \text{ kW}}$$

$$\dot{W}_{\text{rev},\text{out}} = \mathbf{367.3 \text{ kW}}$$

(b) The exergy destroyed in the turbine is

$$\dot{X}_{\text{dest}} = \dot{W}_{\text{rev}} - \dot{W}_a = 367.3 - 257.5 = \mathbf{109.8 \text{ kW}}$$

(c) The second-law efficiency is

$$\eta_{\text{II}} = \frac{\dot{W}_a}{\dot{W}_{\text{rev}}} = \frac{257.5 \text{ kW}}{367.3 \text{ kW}} = 0.701 = \mathbf{70.1\%}$$

8-128 Refrigerant-134a is compressed in an adiabatic compressor, whose second-law efficiency is given. The actual work input, the isentropic efficiency, and the exergy destruction are to be determined.

Assumptions 1 Steady operating conditions exist. 2 Kinetic and potential energy changes are negligible.

Analysis (a) The properties of the refrigerant at the inlet of the compressor are (Tables A-11 through A-13)

$$\begin{aligned} T_{\text{sat}@120\text{kPa}} &= -22.32^\circ\text{C} \\ P_1 &= 120\text{ kPa} \\ T_1 &= (-22.32 + 2.3)^\circ\text{C} = -20^\circ\text{C} \end{aligned} \left. \begin{array}{l} h_1 = 238.84\text{ kJ/kg} \\ s_1 = 0.95523\text{ kJ/kg}\cdot\text{K} \end{array} \right\}$$

The enthalpy at the exit for if the process was isentropic is

$$\begin{aligned} P_2 &= 0.7\text{ MPa} \\ s_2 &= s_1 = 0.95523\text{ kJ/kg}\cdot\text{K} \end{aligned} \left. \begin{array}{l} h_{2s} = 275.79\text{ kJ/kg} \end{array} \right\}$$

The expressions for actual and reversible works are

$$\begin{aligned} w_a &= h_2 - h_1 = (h_2 - 238.84)\text{kJ/kg} \\ w_{\text{rev}} &= h_2 - h_1 - T_0(s_2 - s_1) = (h_2 - 238.84)\text{kJ/kg} - (25 + 273\text{ K})(s_2 - 0.95523)\text{kJ/kg}\cdot\text{K} \end{aligned}$$

Substituting these into the expression for the second-law efficiency

$$\eta_{\text{II}} = \frac{w_{\text{rev}}}{w_a} \rightarrow 0.85 = \frac{h_2 - 238.84 - (298)(s_2 - 0.95523)}{h_2 - 238.84}$$

The exit pressure is given (1 MPa). We need one more property to fix the exit state. By a trial-error approach or using EES, we obtain the exit temperature to be 44.14°C . The corresponding enthalpy and entropy values satisfying this equation are

$$\begin{aligned} h_2 &= 282.72\text{ kJ/kg} \\ s_2 &= 0.9773\text{ kJ/kg}\cdot\text{K} \end{aligned}$$

Then,

$$\begin{aligned} w_a &= h_2 - h_1 = 282.72 - 238.84 = \mathbf{43.88\text{kJ/kg}} \\ w_{\text{rev}} &= h_2 - h_1 - T_0(s_2 - s_1) = (282.72 - 238.84)\text{kJ/kg} - (25 + 273\text{ K})(0.9773 - 0.95523)\text{kJ/kg}\cdot\text{K} = 37.30\text{ kJ/kg} \end{aligned}$$

(b) The isentropic efficiency is determined from its definition

$$\eta_s = \frac{h_{2s} - h_1}{h_2 - h_1} = \frac{(275.79 - 238.84)\text{kJ/kg}}{(282.72 - 238.84)\text{kJ/kg}} = 0.842 = \mathbf{84.2\%}$$

(b) The exergy destroyed in the compressor is

$$x_{\text{dest}} = w_a - w_{\text{rev}} = 43.88 - 37.30 = \mathbf{6.58\text{kJ/kg}}$$

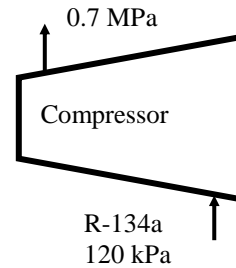

8-129 The isentropic efficiency of a water pump is specified. The actual power output, the rate of frictional heating, the exergy destruction, and the second-law efficiency are to be determined.

Assumptions 1 Steady operating conditions exist. 2 Kinetic and potential energy changes are negligible.

Analysis (a) Using saturated liquid properties at the given temperature for the inlet state (Table A-4)

$$T_1 = 30^\circ\text{C} \left\{ \begin{array}{l} h_1 = 125.82 \text{ kJ/kg} \\ s_1 = 0.4367 \text{ kJ/kg}\cdot\text{K} \\ x_1 = 0 \end{array} \right. \left. \vphantom{T_1} \right\} \nu_1 = 0.001004 \text{ m}^3/\text{kg}$$

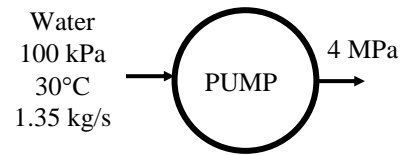

The power input if the process was isentropic is

$$\dot{W}_s = \dot{m}\nu_1(P_2 - P_1) = (1.35 \text{ kg/s})(0.001004 \text{ m}^3/\text{kg})(4000 - 100)\text{kPa} = 5.288 \text{ kW}$$

Given the isentropic efficiency, the actual power may be determined to be

$$\dot{W}_a = \frac{\dot{W}_s}{\eta_s} = \frac{5.288 \text{ kW}}{0.70} = \mathbf{7.554 \text{ kW}}$$

(b) The difference between the actual and isentropic works is the frictional heating in the pump

$$\dot{Q}_{\text{frictional}} = \dot{W}_a - \dot{W}_s = 7.554 - 5.288 = \mathbf{2.266 \text{ kW}}$$

(c) The enthalpy at the exit of the pump for the actual process can be determined from

$$\dot{W}_a = \dot{m}(h_2 - h_1) \longrightarrow 7.554 \text{ kW} = (1.35 \text{ kg/s})(h_2 - 125.82)\text{kJ/kg} \longrightarrow h_2 = 131.42 \text{ kJ/kg}$$

The entropy at the exit is

$$\left. \begin{array}{l} P_2 = 4 \text{ MPa} \\ h_2 = 131.42 \text{ kJ/kg} \end{array} \right\} s_2 = 0.4423 \text{ kJ/kg}\cdot\text{K}$$

The reversible power and the exergy destruction are

$$\begin{aligned} \dot{W}_{\text{rev}} &= \dot{m}[h_2 - h_1 - T_0(s_2 - s_1)] \\ &= (1.35 \text{ kg/s})[(131.42 - 125.82)\text{kJ/kg} - (20 + 273 \text{ K})(0.4423 - 0.4367)\text{kJ/kg}\cdot\text{K}] = 5.362 \text{ kW} \end{aligned}$$

$$\dot{X}_{\text{dest}} = \dot{W}_a - \dot{W}_{\text{rev}} = 7.554 - 5.362 = \mathbf{2.193 \text{ kW}}$$

(d) The second-law efficiency is

$$\eta_{\text{II}} = \frac{\dot{W}_{\text{rev}}}{\dot{W}_a} = \frac{5.362 \text{ kW}}{7.554 \text{ kW}} = 0.710 = \mathbf{71.0\%}$$

8-130 Argon gas is expanded adiabatically in an expansion valve. The exergy of argon at the inlet, the exergy destruction, and the second-law efficiency are to be determined.

Assumptions 1 Steady operating conditions exist. 2 Kinetic and potential energy changes are zero. 3 Argon is an ideal gas with constant specific heats.

Properties The properties of argon gas are $R = 0.2081 \text{ kJ/kg}\cdot\text{K}$, $c_p = 0.5203 \text{ kJ/kg}\cdot^\circ\text{C}$ (Table A-2).

Analysis (a) The exergy of the argon at the inlet is

$$\begin{aligned}\psi_1 &= h_1 - h_0 - T_0(s_1 - s_0) \\ &= c_p(T_1 - T_0) - T_0 \left[c_p \ln \frac{T_1}{T_0} - R \ln \frac{P_1}{P_0} \right] \\ &= (0.5203 \text{ kJ/kg}\cdot\text{K})(100 - 25)^\circ\text{C} - (298 \text{ K}) \left[(0.5203 \text{ kJ/kg}\cdot\text{K}) \ln \frac{373 \text{ K}}{298 \text{ K}} - (0.2081 \text{ kJ/kg}\cdot\text{K}) \ln \frac{3500 \text{ kPa}}{100 \text{ kPa}} \right] \\ &= \mathbf{224.7 \text{ kJ/kg}}\end{aligned}$$

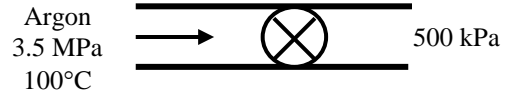

(b) Noting that the temperature remains constant in a throttling process of an ideal gas, the exergy destruction is determined from

$$\begin{aligned}x_{\text{dest}} &= T_0 s_{\text{gen}} \\ &= T_0(s_2 - s_1) \\ &= T_0 \left(-R \ln \frac{P_1}{P_0} \right) = (298 \text{ K}) \left[- (0.2081 \text{ kJ/kg}\cdot\text{K}) \ln \left(\frac{500 \text{ kPa}}{3500 \text{ kPa}} \right) \right] \\ &= \mathbf{120.7 \text{ kJ/kg}}\end{aligned}$$

(c) The second-law efficiency can be determined from

$$\eta_{\text{II}} = \frac{x_{\text{recovered}}}{x_{\text{expended}}} = \frac{0}{\psi_1 - \psi_2} = \frac{0 \text{ kJ/kg}}{(224.7 - 104.0) \text{ kJ/kg}} = 0 = \mathbf{0\%}$$

where

$$\psi_2 = \psi_1 - x_{\text{dest}} = [224.7 - (224.7 - 120.7)] \text{ kJ/kg} = 104.0 \text{ kJ/kg}$$

Discussion An alternative (and different) definition for the second-law efficiency of an expansion valve can be expressed using an “exergy out/exergy in” approach as

$$\eta_{\text{II}} = \frac{x_{\text{out}}}{x_{\text{in}}} = \frac{\psi_2}{\psi_1} = \frac{104.0 \text{ kJ/kg}}{224.7 \text{ kJ/kg}} = 0.463 = 46.3\%$$

Note that an expansion valve is a very wasteful device and it destroys all of the exergy expended in the process. Therefore, we prefer the first approach for the calculation of second-law efficiency.

8-131 Heat is lost from the air flowing in a diffuser. The exit temperature, the rate of exergy destruction, and the second law efficiency are to be determined.

Assumptions 1 Steady operating conditions exist. 2 Potential energy change is negligible. 3 Nitrogen is an ideal gas with variable specific heats.

Properties The gas constant of nitrogen is $R = 0.2968 \text{ kJ/kg}\cdot\text{K}$.

Analysis (a) For this problem, we use the properties from EES software. Remember that for an ideal gas, enthalpy is a function of temperature only whereas entropy is functions of both temperature and pressure. At the inlet of the diffuser and at the dead state, we have

$$\left. \begin{array}{l} T_1 = 110^\circ\text{C} = 383 \text{ K} \\ P_1 = 100 \text{ kPa} \end{array} \right\} \begin{array}{l} h_1 = 88.39 \text{ kJ/kg} \\ s_1 = 7.101 \text{ kJ/kg}\cdot\text{K} \end{array}$$

$$\left. \begin{array}{l} T_0 = 300 \text{ K} \\ P_0 = 100 \text{ kPa} \end{array} \right\} \begin{array}{l} h_0 = 1.93 \text{ kJ/kg} \\ s_0 = 6.846 \text{ kJ/kg}\cdot\text{K} \end{array}$$

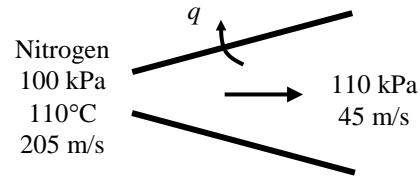

An energy balance on the diffuser gives

$$h_1 + \frac{V_1^2}{2} = h_2 + \frac{V_2^2}{2} + q_{\text{out}}$$

$$88.39 \text{ kJ/kg} + \frac{(205 \text{ m/s})^2}{2} \left(\frac{1 \text{ kJ/kg}}{1000 \text{ m}^2/\text{s}^2} \right) = h_2 + \frac{(45 \text{ m/s})^2}{2} \left(\frac{1 \text{ kJ/kg}}{1000 \text{ m}^2/\text{s}^2} \right) + 2.5 \text{ kJ/kg}$$

$$\longrightarrow h_2 = 105.9 \text{ kJ/kg}$$

The corresponding properties at the exit of the diffuser are

$$\left. \begin{array}{l} h_2 = 105.9 \text{ kJ/kg} \\ P_2 = 110 \text{ kPa} \end{array} \right\} \begin{array}{l} T_2 = \mathbf{127^\circ\text{C}} = 400 \text{ K} \\ s_2 = 7.117 \text{ kJ/kg}\cdot\text{K} \end{array}$$

(b) The mass flow rate of the nitrogen is determined to be

$$\dot{m} = \rho_2 A_2 V_2 = \frac{P_2}{RT_2} A_2 V_2 = \frac{110 \text{ kPa}}{(0.2968 \text{ kJ/kg}\cdot\text{K})(400 \text{ K})} (0.04 \text{ m}^2)(45 \text{ m/s}) = 1.669 \text{ kg/s}$$

The exergy destruction in the nozzle is the exergy difference between the inlet and exit of the diffuser:

$$\dot{X}_{\text{dest}} = \dot{m} \left[h_1 - h_2 + \frac{V_1^2 - V_2^2}{2} - T_0 (s_1 - s_2) \right]$$

$$= (1.669 \text{ kg/s}) \left[(88.39 - 105.9) \text{ kJ/kg} + \frac{(205 \text{ m/s})^2 - (45 \text{ m/s})^2}{2} \left(\frac{1 \text{ kJ/kg}}{1000 \text{ m}^2/\text{s}^2} \right) - (300 \text{ K})(7.101 - 7.117) \text{ kJ/kg}\cdot\text{K} \right] = \mathbf{12.4 \text{ kW}}$$

(c) The second-law efficiency for this device may be defined as the exergy output divided by the exergy input:

$$\dot{X}_1 = \dot{m} \left[h_1 - h_0 + \frac{V_1^2}{2} - T_0 (s_1 - s_0) \right]$$

$$= (1.669 \text{ kg/s}) \left[(88.39 - 1.93) \text{ kJ/kg} + \frac{(205 \text{ m/s})^2}{2} \left(\frac{1 \text{ kJ/kg}}{1000 \text{ m}^2/\text{s}^2} \right) - (300 \text{ K})(7.101 - 6.846) \text{ kJ/kg}\cdot\text{K} \right]$$

$$= 51.96 \text{ kW}$$

$$\eta_{\text{II}} = \frac{\dot{X}_2}{\dot{X}_1} = 1 - \frac{\dot{X}_{\text{dest}}}{\dot{X}_1} = 1 - \frac{12.4 \text{ kW}}{51.96 \text{ kW}} = 0.761 = \mathbf{76.1\%}$$

8-132 A relation for the second-law efficiency of a heat engine operating between a heat source and a heat sink at specified temperatures is to be obtained.

Analysis The second-law efficiency is defined as the ratio of the availability (exergy) recovered to availability supplied during a process. The work W produced is the availability recovered. The decrease in the availability of the heat supplied Q_H is the availability supplied or invested.

Therefore,

$$\eta_{II} = \frac{W}{\left(1 - \frac{T_0}{T_H}\right)Q_H - \left(1 - \frac{T_0}{T_L}\right)Q_L}$$

Note that the first term in the denominator is the availability of heat supplied to the heat engine whereas the second term is the availability of the heat rejected by the heat engine. The difference between the two is the availability expended during the process.

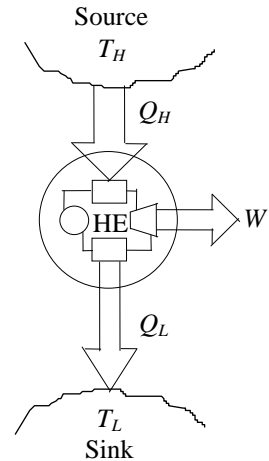

8-133 Writing energy and entropy balances, a relation for the reversible work is to be obtained for a closed system that exchanges heat with surroundings at T_0 in the amount of Q_0 as well as a heat reservoir at temperature T_R in the amount Q_R .

Assumptions Kinetic and potential changes are negligible.

Analysis We take the direction of heat transfers to be to the system (heat input) and the direction of work transfer to be from the system (work output). The result obtained is still general since quantities with opposite directions can be handled the same way by using negative signs. The energy and entropy balances for this stationary closed system can be expressed as

$$\text{Energy balance: } E_{\text{in}} - E_{\text{out}} = \Delta E_{\text{system}} \rightarrow Q_0 + Q_R - W = U_2 - U_1 \longrightarrow W = U_1 - U_2 + Q_0 + Q_R \quad (1)$$

$$\text{Entropy balance: } S_{\text{in}} - S_{\text{out}} + S_{\text{gen}} = \Delta S_{\text{system}} \rightarrow S_{\text{gen}} = (S_2 - S_1) + \frac{-Q_R}{T_R} + \frac{-Q_0}{T_0} \quad (2)$$

Solving for Q_0 from (2) and substituting in (1) yields

$$W = (U_1 - U_2) - T_0(S_1 - S_2) - Q_R \left(1 - \frac{T_0}{T_R}\right) - T_0 S_{\text{gen}}$$

The useful work relation for a closed system is obtained from

$$\begin{aligned} W_u &= W - W_{\text{surr}} \\ &= (U_1 - U_2) - T_0(S_1 - S_2) - Q_R \left(1 - \frac{T_0}{T_R}\right) - T_0 S_{\text{gen}} - P_0(V_2 - V_1) \end{aligned}$$

Then the reversible work relation is obtained by substituting $S_{\text{gen}} = 0$,

$$W_{\text{rev}} = (U_1 - U_2) - T_0(S_1 - S_2) + P_0(V_1 - V_2) - Q_R \left(1 - \frac{T_0}{T_R}\right)$$

A positive result for W_{rev} indicates work output, and a negative result work input. Also, the Q_R is a positive quantity for heat transfer to the system, and a negative quantity for heat transfer from the system.

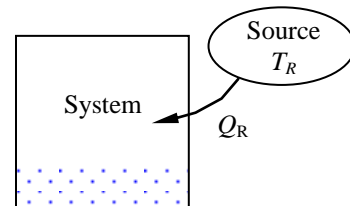

8-134 Writing energy and entropy balances, a relation for the reversible work is to be obtained for a steady-flow system that exchanges heat with surroundings at T_0 at a rate of \dot{Q}_0 as well as a heat reservoir at temperature T_R in the amount \dot{Q}_R .

Analysis We take the direction of heat transfers to be to the system (heat input) and the direction of work transfer to be from the system (work output). The result obtained is still general since quantities with opposite directions can be handled the same way by using negative signs. The energy and entropy balances for this stationary closed system can be expressed as

Energy balance: $\dot{E}_{\text{in}} - \dot{E}_{\text{out}} = \Delta \dot{E}_{\text{system}} \rightarrow \dot{E}_{\text{in}} = \dot{E}_{\text{out}}$

$$\dot{Q}_0 + \dot{Q}_R - \dot{W} = \sum \dot{m}_e \left(h_e + \frac{V_e^2}{2} + gz_e \right) - \sum \dot{m}_i \left(h_i + \frac{V_i^2}{2} + gz_i \right)$$

or
$$\dot{W} = \sum \dot{m}_i \left(h_i + \frac{V_i^2}{2} + gz_i \right) - \sum \dot{m}_e \left(h_e + \frac{V_e^2}{2} + gz_e \right) + \dot{Q}_0 + \dot{Q}_R \quad (1)$$

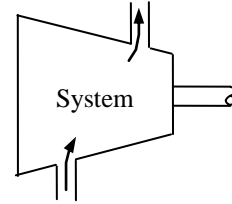

Entropy balance:

$$\dot{S}_{\text{in}} - \dot{S}_{\text{out}} + \dot{S}_{\text{gen}} = \Delta \dot{S}_{\text{system}} = 0$$

$$\dot{S}_{\text{gen}} = \dot{S}_{\text{out}} - \dot{S}_{\text{in}}$$

$$\dot{S}_{\text{gen}} = \sum \dot{m}_e s_e - \sum \dot{m}_i s_i + \frac{-\dot{Q}_R}{T_R} + \frac{-\dot{Q}_0}{T_0} \quad (2)$$

Solving for \dot{Q}_0 from (2) and substituting in (1) yields

$$\dot{W} = \sum \dot{m}_i \left(h_i + \frac{V_i^2}{2} + gz_i - T_0 s_i \right) - \sum \dot{m}_e \left(h_e + \frac{V_e^2}{2} + gz_e - T_0 s_e \right) - T_0 \dot{S}_{\text{gen}} - \dot{Q}_R \left(1 - \frac{T_0}{T_R} \right)$$

Then the reversible work relation is obtained by substituting $\dot{S}_{\text{gen}} = 0$,

$$\dot{W}_{\text{rev}} = \sum \dot{m}_i \left(h_i + \frac{V_i^2}{2} + gz_i - T_0 s_i \right) - \sum \dot{m}_e \left(h_e + \frac{V_e^2}{2} + gz_e - T_0 s_e \right) - \dot{Q}_R \left(1 - \frac{T_0}{T_R} \right)$$

A positive result for \dot{W}_{rev} indicates work output, and a negative result work input. Also, the \dot{Q}_R is a positive quantity for heat transfer to the system, and a negative quantity for heat transfer from the system.

8-135 Writing energy and entropy balances, a relation for the reversible work is to be obtained for a uniform-flow system that exchanges heat with surroundings at T_0 in the amount of Q_0 as well as a heat reservoir at temperature T_R in the amount Q_R .

Assumptions Kinetic and potential changes are negligible.

Analysis We take the direction of heat transfers to be to the system (heat input) and the direction of work transfer to be from the system (work output). The result obtained is still general since quantities with opposite directions can be handled the same way by using negative signs. The energy and entropy balances for this stationary closed system can be expressed as

Energy balance: $E_{\text{in}} - E_{\text{out}} = \Delta E_{\text{system}}$

$$Q_0 + Q_R - W = \sum m_e \left(h_e + \frac{V_e^2}{2} + gz_e \right) - \sum m_i \left(h_i + \frac{V_i^2}{2} + gz_i \right) + (U_2 - U_1)_{\text{cv}}$$

or,
$$W = \sum m_i \left(h_i + \frac{V_i^2}{2} + gz_i \right) - \sum m_e \left(h_e + \frac{V_e^2}{2} + gz_e \right) - (U_2 - U_1)_{\text{cv}} + Q_0 + Q_R \quad (1)$$

Entropy balance: $S_{\text{in}} - S_{\text{out}} + S_{\text{gen}} = \Delta S_{\text{system}}$

$$S_{\text{gen}} = (S_2 - S_1)_{\text{cv}} + \sum m_e s_e - \sum m_i s_i + \frac{-Q_R}{T_R} + \frac{-Q_0}{T_0} \quad (2)$$

Solving for Q_0 from (2) and substituting in (1) yields

$$W = \sum m_i \left(h_i + \frac{V_i^2}{2} + gz_i - T_0 s_i \right) - \sum m_e \left(h_e + \frac{V_e^2}{2} + gz_e - T_0 s_e \right) + [(U_1 - U_2) - T_0 (S_1 - S_2)]_{\text{cv}} - T_0 S_{\text{gen}} - Q_R \left(1 - \frac{T_0}{T_R} \right)$$

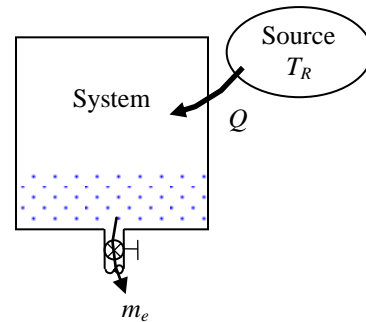

The useful work relation for a closed system is obtained from

$$W_u = W - W_{\text{surr}} = \sum m_i \left(h_i + \frac{V_i^2}{2} + gz_i - T_0 s_i \right) - \sum m_e \left(h_e + \frac{V_e^2}{2} + gz_e - T_0 s_e \right) + [(U_1 - U_2) - T_0 (S_1 - S_2)]_{\text{cv}} - T_0 S_{\text{gen}} - Q_R \left(1 - \frac{T_0}{T_R} \right) - P_0 (V_2 - V_1)$$

Then the reversible work relation is obtained by substituting $S_{\text{gen}} = 0$,

$$W_{\text{rev}} = \sum m_i \left(h_i + \frac{V_i^2}{2} + gz_i - T_0 s_i \right) - \sum m_e \left(h_e + \frac{V_e^2}{2} + gz_e - T_0 s_e \right) + [(U_1 - U_2) - T_0 (S_1 - S_2) + P_0 (V_1 - V_2)]_{\text{cv}} - Q_R \left(1 - \frac{T_0}{T_R} \right)$$

A positive result for W_{rev} indicates work output, and a negative result work input. Also, the Q_R is a positive quantity for heat transfer to the system, and a negative quantity for heat transfer from the system.

Fundamentals of Engineering (FE) Exam Problems

8-136 Heat is lost through a plane wall steadily at a rate of 800 W. If the inner and outer surface temperatures of the wall are 20°C and 5°C, respectively, and the environment temperature is 0°C, the rate of exergy destruction within the wall is

- (a) 40 W (b) 17,500 W (c) 765 W (d) 32,800 W (e) 0 W

Answer (a) 40 W

Solution Solved by EES Software. Solutions can be verified by copying-and-pasting the following lines on a blank EES screen. (Similar problems and their solutions can be obtained easily by modifying numerical values).

```
Q=800 "W"
T1=20 "C"
T2=5 "C"
To=0 "C"
"Entropy balance S_in - S_out + S_gen= DS_system for the wall for steady operation gives"
Q/(T1+273)-Q/(T2+273)+S_gen=0 "W/K"
X_dest=(To+273)*S_gen "W"
```

"Some Wrong Solutions with Common Mistakes:"

```
Q/T1-Q/T2+Sgen1=0; W1_Xdest=(To+273)*Sgen1 "Using C instead of K in Sgen"
Sgen2=Q/((T1+T2)/2); W2_Xdest=(To+273)*Sgen2 "Using avegage temperature in C for Sgen"
Sgen3=Q/((T1+T2)/2+273); W3_Xdest=(To+273)*Sgen3 "Using avegage temperature in K"
W4_Xdest=To*S_gen "Using C for To"
```

8-137 Liquid water enters an adiabatic piping system at 15°C at a rate of 3 kg/s. It is observed that the water temperature rises by 0.3°C in the pipe due to friction. If the environment temperature is also 15°C, the rate of exergy destruction in the pipe is

- (a) 3.8 kW (b) 24 kW (c) 72 kW (d) 98 kW (e) 124 kW

Answer (a) 3.8 kW

Solution Solved by EES Software. Solutions can be verified by copying-and-pasting the following lines on a blank EES screen. (Similar problems and their solutions can be obtained easily by modifying numerical values).

```
Cp=4.18 "kJ/kg.K"
m=3 "kg/s"
T1=15 "C"
T2=15.3 "C"
To=15 "C"
S_gen=m*Cp*ln((T2+273)/(T1+273)) "kW/K"
X_dest=(To+273)*S_gen "kW"
```

"Some Wrong Solutions with Common Mistakes:"

```
W1_Xdest=(To+273)*m*Cp*ln(T2/T1) "Using deg. C in Sgen"
W2_Xdest=To*m*Cp*ln(T2/T1) "Using deg. C in Sgen and To"
W3_Xdest=(To+273)*Cp*ln(T2/T1) "Not using mass flow rate with deg. C"
W4_Xdest=(To+273)*Cp*ln((T2+273)/(T1+273)) "Not using mass flow rate with K"
```

8-138 A heat engine receives heat from a source at 1500 K at a rate of 600 kJ/s and rejects the waste heat to a sink at 300 K. If the power output of the engine is 400 kW, the second-law efficiency of this heat engine is

- (a) 42% (b) 53% (c) 83% (d) 67% (e) 80%

Answer (c) 83%

Solution Solved by EES Software. Solutions can be verified by copying-and-pasting the following lines on a blank EES screen. (Similar problems and their solutions can be obtained easily by modifying numerical values).

```
Qin=600 "kJ/s"
W=400 "kW"
TL=300 "K"
TH=1500 "K"
Eta_rev=1-TL/TH
Eta_th=W/Qin
Eta_II=Eta_th/Eta_rev
```

"Some Wrong Solutions with Common Mistakes:"

```
W1_Eta_II=Eta_th1/Eta_rev; Eta_th1=1-W/Qin "Using wrong relation for thermal efficiency"
W2_Eta_II=Eta_th "Taking second-law efficiency to be thermal efficiency"
W3_Eta_II=Eta_rev "Taking second-law efficiency to be reversible efficiency"
W4_Eta_II=Eta_th*Eta_rev "Multiplying thermal and reversible efficiencies instead of dividing"
```

8-139 A water reservoir contains 100 tons of water at an average elevation of 60 m. The maximum amount of electric power that can be generated from this water is

- (a) 8 kWh (b) 16 kWh (c) 1630 kWh (d) 16,300 kWh (e) 58,800 kWh

Answer (b) 16 kWh

Solution Solved by EES Software. Solutions can be verified by copying-and-pasting the following lines on a blank EES screen. (Similar problems and their solutions can be obtained easily by modifying numerical values).

```
m=100000 "kg"
h=60 "m"
g=9.81 "m/s^2"
"Maximum power is simply the potential energy change,"
W_max=m*g*h/1000 "kJ"
W_max_kWh=W_max/3600 "kWh"
```

"Some Wrong Solutions with Common Mistakes:"

```
W1_Wmax =m*g*h/3600 "Not using the conversion factor 1000"
W2_Wmax =m*g*h/1000 "Obtaining the result in kJ instead of kWh"
W3_Wmax =m*g*h*3.6/1000 "Using wrong conversion factor"
W4_Wmax =m*h/3600 "Not using g and the factor 1000 in calculations"
```

8-140 A house is maintained at 21°C in winter by electric resistance heaters. If the outdoor temperature is 9°C, the second-law efficiency of the resistance heaters is

- (a) 0% (b) 4.1% (c) 5.7% (d) 25% (e) 100%

Answer (b) 4.1%

Solution Solved by EES Software. Solutions can be verified by copying-and-pasting the following lines on a blank EES screen. (Similar problems and their solutions can be obtained easily by modifying numerical values).

```
TL=9+273 "K"
TH=21+273 "K"
To=TL
COP_rev=TH/(TH-TL)
COP=1
Eta_II=COP/COP_rev
```

"Some Wrong Solutions with Common Mistakes:"

```
W1_Eta_II=COP/COP_rev1; COP_rev1=TL/(TH-TL) "Using wrong relation for COP_rev"
W2_Eta_II=1-(TL-273)/(TH-273) "Taking second-law efficiency to be reversible thermal efficiency with C for temp"
W3_Eta_II=COP_rev "Taking second-law efficiency to be reversible COP"
W4_Eta_II=COP_rev2/COP; COP_rev2=(TL-273)/(TH-TL) "Using C in COP_rev relation instead of K, and reversing"
```

8-141 A 12-kg solid whose specific heat is 2.8 kJ/kg·°C is at a uniform temperature of -10°C. For an environment temperature of 20°C, the exergy content of this solid is

- (a) Less than zero (b) 0 kJ (c) 4.6 kJ (d) 55 kJ (e) 1008 kJ

Answer (d) 55 kJ

Solution Solved by EES Software. Solutions can be verified by copying-and-pasting the following lines on a blank EES screen. (Similar problems and their solutions can be obtained easily by modifying numerical values).

```
m=12 [kg]
cp=2.8 [kJ/kg-K]
T1=(-10+273) [K]
To=(20+273) [K]
```

```
"Exergy content of a fixed mass is  $x_1 = u_1 - u_o - T_o(s_1 - s_o) + P_o(v_1 - v_o)$ "
ex=m*(cp*(T1-To)-To*cp*ln(T1/To))
```

"Some Wrong Solutions with Common Mistakes:"

```
W1_ex=m*cp*(To-T1) "Taking the energy content as the exergy content"
W2_ex=m*(cp*(T1-To)+To*cp*ln(T1/To)) "Using + for the second term instead of -"
W3_ex=cp*(T1-To)-To*cp*ln(T1/To) "Using exergy content per unit mass"
W4_ex=0 "Taking the exergy content to be zero"
```

8-142 Keeping the limitations imposed by the second-law of thermodynamics in mind, choose the wrong statement below:

- (a) A heat engine cannot have a thermal efficiency of 100%.
- (b) For all reversible processes, the second-law efficiency is 100%.
- (c) The second-law efficiency of a heat engine cannot be greater than its thermal efficiency.
- (d) The second-law efficiency of a process is 100% if no entropy is generated during that process.
- (e) The coefficient of performance of a refrigerator can be greater than 1.

Answer (c) The second-law efficiency of a heat engine cannot be greater than its thermal efficiency.

8-143 A furnace can supply heat steadily at a 1300 K at a rate of 500 kJ/s. The maximum amount of power that can be produced by using the heat supplied by this furnace in an environment at 300 K is

- (a) 115 kW
- (b) 192 kW
- (c) 385 kW
- (d) 500 kW
- (e) 650 kW

Answer (c) 385 kW

Solution Solved by EES Software. Solutions can be verified by copying-and-pasting the following lines on a blank EES screen. (Similar problems and their solutions can be obtained easily by modifying numerical values).

```
Q_in=500 "kJ/s"
TL=300 "K"
TH=1300 "K"
W_max=Q_in*(1-TL/TH) "kW"
```

"Some Wrong Solutions with Common Mistakes:"

```
W1_Wmax=W_max/2 "Taking half of Wmax"
W2_Wmax=Q_in/(1-TL/TH) "Dividing by efficiency instead of multiplying by it"
W3_Wmax =Q_in*TL/TH "Using wrong relation"
W4_Wmax=Q_in "Assuming entire heat input is converted to work"
```

8-144 Air is throttled from 50°C and 800 kPa to a pressure of 200 kPa at a rate of 0.5 kg/s in an environment at 25°C. The change in kinetic energy is negligible, and no heat transfer occurs during the process. The power potential wasted during this process is

- (a) 0 (b) 0.20 kW (c) 47 kW (d) 59 kW (e) 119 kW

Answer (d) 59 kW

Solution Solved by EES Software. Solutions can be verified by copying-and-pasting the following lines on a blank EES screen. (Similar problems and their solutions can be obtained easily by modifying numerical values).

```
R=0.287 "kJ/kg.K"
Cp=1.005 "kJ/kg.K"
m=0.5 "kg/s"
T1=50+273 "K"
P1=800 "kPa"
To=25 "C"
P2=200 "kPa"
"Temperature of an ideal gas remains constant during throttling since h=const and h=h(T)"
T2=T1
ds=Cp*ln(T2/T1)-R*ln(P2/P1)
X_dest=(To+273)*m*ds "kW"
```

"Some Wrong Solutions with Common Mistakes:"

```
W1_dest=0 "Assuming no loss"
W2_dest=(To+273)*ds "Not using mass flow rate"
W3_dest=To*m*ds "Using C for To instead of K"
W4_dest=m*(P1-P2) "Using wrong relations"
```

8-145 Steam enters a turbine steadily at 4 MPa and 400°C and exits at 0.2 MPa and 150°C in an environment at 25°C. The decrease in the exergy of the steam as it flows through the turbine is

- (a) 58 kJ/kg (b) 445 kJ/kg (c) 458 kJ/kg (d) 518 kJ/kg (e) 597 kJ/kg

Answer (e) 597 kJ/kg

Solution Solved by EES Software. Solutions can be verified by copying-and-pasting the following lines on a blank EES screen. (Similar problems and their solutions can be obtained easily by modifying numerical values).

```
P1=4000 "kPa"
T1=400 "C"
P2=200 "kPa"
T2=150 "C"
To=25 "C"
h1=ENTHALPY(Steam_IAPWS,T=T1,P=P1)
s1=ENTROPY(Steam_IAPWS,T=T1,P=P1)
h2=ENTHALPY(Steam_IAPWS,T=T2,P=P2)
s2=ENTROPY(Steam_IAPWS,T=T2,P=P2)
"Exergy change of s fluid stream is Dx=h2-h1-To*(s2-s1)"
-Dx=h2-h1-(To+273)*(s2-s1)
```

"Some Wrong Solutions with Common Mistakes:"

```
-W1_Dx=0 "Assuming no exergy destruction"
-W2_Dx=h2-h1 "Using enthalpy change"
-W3_Dx=h2-h1-To*(s2-s1) "Using C for To instead of K"
-W4_Dx=(h2+(T2+273)*s2)-(h1+(T1+273)*s1) "Using wrong relations for exergy"
```

8- 146 ... 8- 150 Design and Essay Problems



Solutions Manual for
Thermodynamics: An Engineering Approach
8th Edition
Yunus A. Çengel, Michael A. Boles
McGraw-Hill, 2015

Chapter 9

GAS POWER CYCLES

PROPRIETARY AND CONFIDENTIAL

This Manual is the proprietary property of McGraw-Hill Education and protected by copyright and other state and federal laws. By opening and using this Manual the user agrees to the following restrictions, and if the recipient does not agree to these restrictions, the Manual should be promptly returned unopened to McGraw-Hill Education: **This Manual is being provided only to authorized professors and instructors for use in preparing for the classes using the affiliated textbook. No other use or distribution of this Manual is permitted. This Manual may not be sold and may not be distributed to or used by any student or other third party. No part of this Manual may be reproduced, displayed or distributed in any form or by any means, electronic or otherwise, without the prior written permission of McGraw-Hill Education.**

Actual and Ideal Cycles, Carnot cycle, Air-Standard Assumptions, Reciprocating Engines

9-1C The air standard assumptions are: (1) the working fluid is air which behaves as an ideal gas, (2) all the processes are internally reversible, (3) the combustion process is replaced by the heat addition process, and (4) the exhaust process is replaced by the heat rejection process which returns the working fluid to its original state.

9-2C The cold air standard assumptions involves the additional assumption that air can be treated as an ideal gas with constant specific heats at room temperature.

9-3C It is less than the thermal efficiency of a Carnot cycle.

9-4C It represents the net work on both diagrams.

9-5C It is the ratio of the maximum to minimum volumes in the cylinder.

9-6C The MEP is the fictitious pressure which, if acted on the piston during the entire power stroke, would produce the same amount of net work as that produced during the actual cycle.

9-7C Yes.

9-8C Assuming no accumulation of carbon deposits on the piston face, the compression ratio will remain the same (otherwise it will increase). The mean effective pressure, on the other hand, will decrease as a car gets older as a result of wear and tear.

9-9C The SI and CI engines differ from each other in the way combustion is initiated; by a spark in SI engines, and by compressing the air above the self-ignition temperature of the fuel in CI engines.

9-10C Stroke is the distance between the TDC and the BDC, bore is the diameter of the cylinder, TDC is the position of the piston when it forms the smallest volume in the cylinder, and clearance volume is the minimum volume formed in the cylinder.

9-11E The maximum possible thermal efficiency of a gas power cycle with specified reservoirs is to be determined.

Analysis The maximum efficiency this cycle can have is

$$\eta_{\text{th,Carnot}} = 1 - \frac{T_L}{T_H} = 1 - \frac{(80 + 460) \text{ R}}{(1100 + 460) \text{ R}} = 0.654 = \mathbf{65.4\%}$$

9-12 The three processes of an air-standard cycle are described. The cycle is to be shown on the P - v and T - s diagrams, and the back work ratio and the thermal efficiency are to be determined.

Assumptions 1 The air-standard assumptions are applicable. **2** Kinetic and potential energy changes are negligible. **3** Air is an ideal gas with constant specific heats.

Properties The properties of air are given as $R = 0.287 \text{ kJ/kg}\cdot\text{K}$, $c_p = 1.005 \text{ kJ/kg}\cdot\text{K}$, $c_v = 0.718 \text{ kJ/kg}\cdot\text{K}$, and $k = 1.4$.

Analysis (a) The P - v and T - s diagrams of the cycle are shown in the figures.

(b) The temperature at state 2 is

$$T_2 = T_1 \frac{P_2}{P_1} = (300 \text{ K}) \frac{700 \text{ kPa}}{100 \text{ kPa}} = 2100 \text{ K}$$

$$T_3 = T_2 = 2100 \text{ K}$$

During process 1-3, we have

$$\begin{aligned} w_{3-1,in} &= -\int_3^1 P d v = -P_1 (v_1 - v_3) = -R(T_1 - T_3) \\ &= -(0.287 \text{ kJ/kg}\cdot\text{K})(300 - 2100)\text{K} = 516.6 \text{ kJ/kg} \end{aligned}$$

During process 2-3, we have

$$\begin{aligned} w_{2-3,out} &= \int_2^3 P d v = \int_2^3 \frac{RT}{v} d v = RT \ln \frac{v_3}{v_2} = RT \ln \frac{7v_2}{v_2} = RT \ln 7 \\ &= (0.287 \text{ kJ/kg}\cdot\text{K})(2100)\text{K} \ln 7 = 1172.8 \text{ kJ/kg} \end{aligned}$$

The back work ratio is then

$$r_{bw} = \frac{w_{3-1,in}}{w_{2-3,out}} = \frac{516.6 \text{ kJ/kg}}{1172.8 \text{ kJ/kg}} = \mathbf{0.440}$$

Heat input is determined from an energy balance on the cycle during process 1-3,

$$\begin{aligned} q_{1-3,in} - w_{2-3,out} &= \Delta u_{1-3} \\ q_{1-3,in} &= \Delta u_{1-3} + w_{2-3,out} \\ &= c_v (T_3 - T_1) + w_{2-3,out} \\ &= (0.718 \text{ kJ/kg}\cdot\text{K})(2100 - 300) + 1172.8 \text{ kJ/kg} \\ &= 2465 \text{ kJ/kg} \end{aligned}$$

The net work output is

$$w_{net} = w_{2-3,out} - w_{3-1,in} = 1172.8 - 516.6 = 656.2 \text{ kJ/kg}$$

(c) The thermal efficiency is then

$$\eta_{th} = \frac{w_{net}}{q_{in}} = \frac{656.2 \text{ kJ}}{2465 \text{ kJ}} = 0.266 = \mathbf{26.6\%}$$

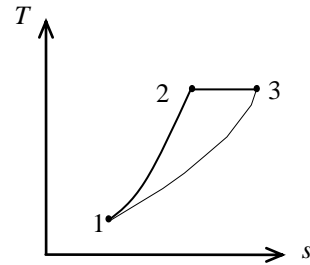
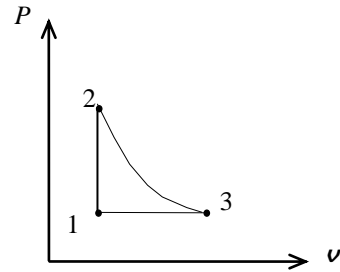

9-13 The four processes of an air-standard cycle are described. The cycle is to be shown on P - v and T - s diagrams, and the net work output and the thermal efficiency are to be determined.

Assumptions 1 The air-standard assumptions are applicable. **2** Kinetic and potential energy changes are negligible. **3** Air is an ideal gas with variable specific heats.

Properties The properties of air are given in Table A-17.

Analysis (b) The properties of air at various states are

$$T_1 = 295 \text{ K} \longrightarrow \begin{aligned} h_1 &= 295.17 \text{ kJ/kg} \\ P_{r_1} &= 1.3068 \end{aligned}$$

$$P_{r_2} = \frac{P_2}{P_1} P_{r_1} = \frac{600 \text{ kPa}}{100 \text{ kPa}} (1.3068) = 7.841 \longrightarrow \begin{aligned} u_2 &= 352.29 \text{ kJ/kg} \\ T_2 &= 490.3 \text{ K} \end{aligned}$$

$$T_3 = 1500 \text{ K} \longrightarrow \begin{aligned} u_3 &= 1205.41 \text{ kJ/kg} \\ P_{r_3} &= 601.9 \end{aligned}$$

$$\frac{P_3 v_3}{T_3} = \frac{P_2 v_2}{T_2} \longrightarrow P_3 = \frac{T_3}{T_2} P_2 = \frac{1500 \text{ K}}{490.3 \text{ K}} (600 \text{ kPa}) = 1835.6 \text{ kPa}$$

$$P_{r_4} = \frac{P_4}{P_3} P_{r_3} = \frac{100 \text{ kPa}}{1835.6 \text{ kPa}} (601.9) = 32.79 \longrightarrow h_4 = 739.71 \text{ kJ/kg}$$

From energy balances,

$$q_{\text{in}} = u_3 - u_2 = 1205.41 - 352.29 = 853.1 \text{ kJ/kg}$$

$$q_{\text{out}} = h_4 - h_1 = 739.71 - 295.17 = 444.5 \text{ kJ/kg}$$

$$w_{\text{net,out}} = q_{\text{in}} - q_{\text{out}} = 853.1 - 444.5 = \mathbf{408.6 \text{ kJ/kg}}$$

(c) Then the thermal efficiency becomes

$$\eta_{\text{th}} = \frac{w_{\text{net,out}}}{q_{\text{in}}} = \frac{408.6 \text{ kJ/kg}}{853.1 \text{ kJ/kg}} = 0.479 = \mathbf{47.9\%}$$

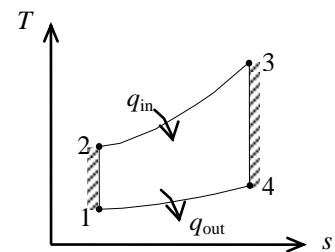
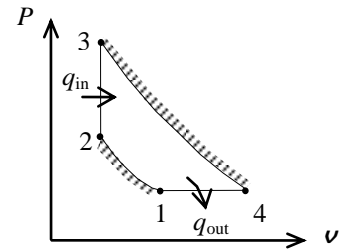



9-14 Problem 9-13 is reconsidered. The effect of the maximum temperature of the cycle on the net work output and thermal efficiency is to be investigated. Also, T - s and P - v diagrams for the cycle are to be plotted.

Analysis Using EES, the problem is solved as follows:

"Input Data"

$T[1]=295$ [K]
 $P[1]=100$ [kPa]
 $P[2] = 600$ [kPa]
 $T[3]=1500$ [K]
 $P[4] = 100$ [kPa]

"Process 1-2 is isentropic compression"

$s[1]=\text{entropy}(\text{air}, T=T[1], P=P[1])$
 $s[2]=s[1]$
 $T[2]=\text{temperature}(\text{air}, s=s[2], P=P[2])$
 $P[2]*v[2]/T[2]=P[1]*v[1]/T[1]$
 $P[1]*v[1]=R*T[1]$
 $R=0.287$ [kJ/kg-K]

"Conservation of energy for process 1 to 2"

$q_{12} - w_{12} = \text{DELTA}u_{12}$
 $q_{12} = 0$ "isentropic process"
 $\text{DELTA}u_{12} = \text{intenergy}(\text{air}, T=T[2]) - \text{intenergy}(\text{air}, T=T[1])$

"Process 2-3 is constant volume heat addition"

$s[3]=\text{entropy}(\text{air}, T=T[3], P=P[3])$
 $\{P[3]*v[3]/T[3]=P[2]*v[2]/T[2]\}$
 $P[3]*v[3]=R*T[3]$
 $v[3]=v[2]$

"Conservation of energy for process 2 to 3"

$q_{23} - w_{23} = \text{DELTA}u_{23}$
 $w_{23} = 0$ "constant volume process"
 $\text{DELTA}u_{23} = \text{intenergy}(\text{air}, T=T[3]) - \text{intenergy}(\text{air}, T=T[2])$

"Process 3-4 is isentropic expansion"

$s[4]=\text{entropy}(\text{air}, T=T[4], P=P[4])$
 $s[4]=s[3]$
 $P[4]*v[4]/T[4]=P[3]*v[3]/T[3]$
 $\{P[4]*v[4]=0.287*T[4]\}$

"Conservation of energy for process 3 to 4"

$q_{34} - w_{34} = \text{DELTA}u_{34}$
 $q_{34} = 0$ "isentropic process"
 $\text{DELTA}u_{34} = \text{intenergy}(\text{air}, T=T[4]) - \text{intenergy}(\text{air}, T=T[3])$

"Process 4-1 is constant pressure heat rejection"

$\{P[4]*v[4]/T[4]=P[1]*v[1]/T[1]\}$

"Conservation of energy for process 4 to 1"

$q_{41} - w_{41} = \text{DELTA}u_{41}$
 $w_{41} = P[1]*(v[1]-v[4])$ "constant pressure process"
 $\text{DELTA}u_{41} = \text{intenergy}(\text{air}, T=T[1]) - \text{intenergy}(\text{air}, T=T[4])$
 $q_{in_total} = q_{23}$

$w_{net} = w_{12} + w_{23} + w_{34} + w_{41}$
 $\text{Eta}_{th} = w_{net}/q_{in_total} * 100$ "Thermal efficiency, in percent"

T_3 [K]	η_{th}	$q_{in,total}$ [kJ/kg]	W_{net} [kJ/kg]
1500	47.91	852.9	408.6
1600	48.31	945.7	456.9
1700	48.68	1040	506.1
1800	49.03	1134	556
1900	49.35	1229	606.7
2000	49.66	1325	658.1
2100	49.95	1422	710.5
2200	50.22	1519	763
2300	50.48	1617	816.1
2400	50.72	1715	869.8
2500	50.95	1813	924

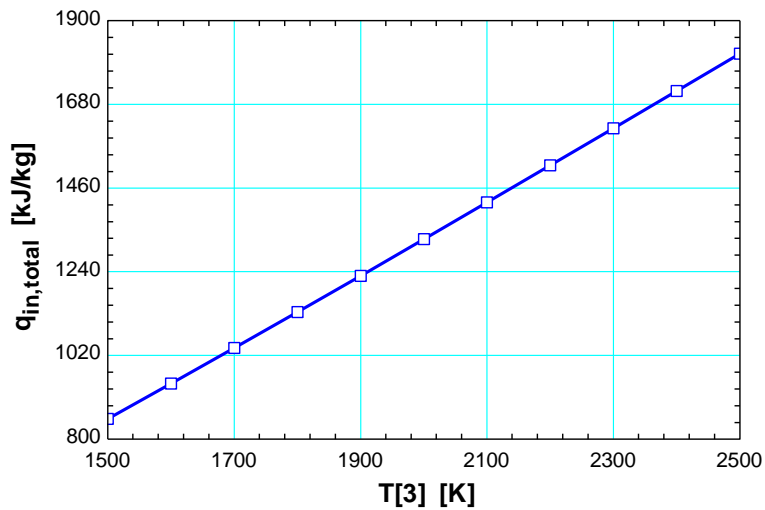
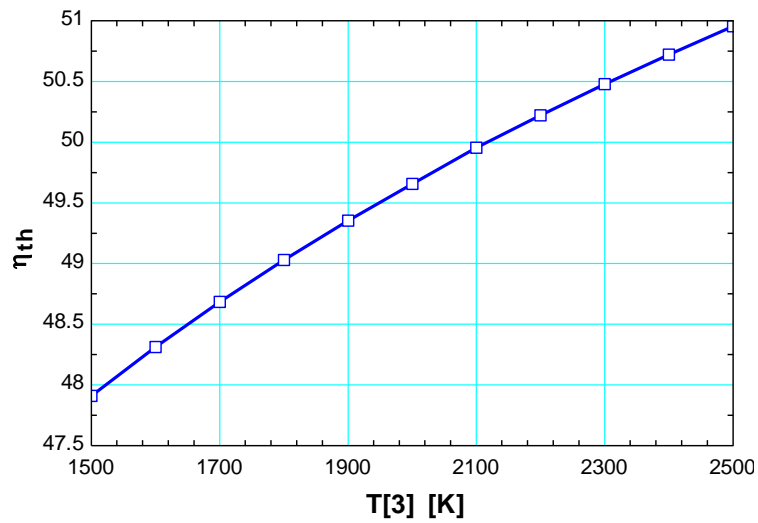

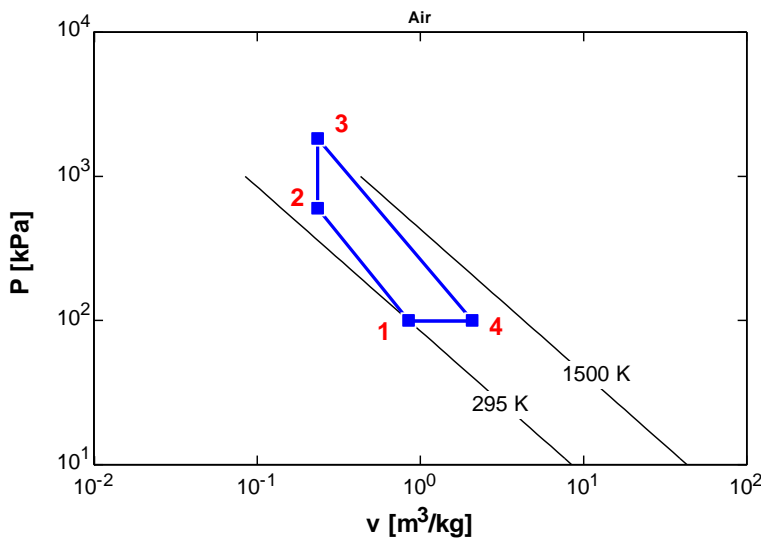
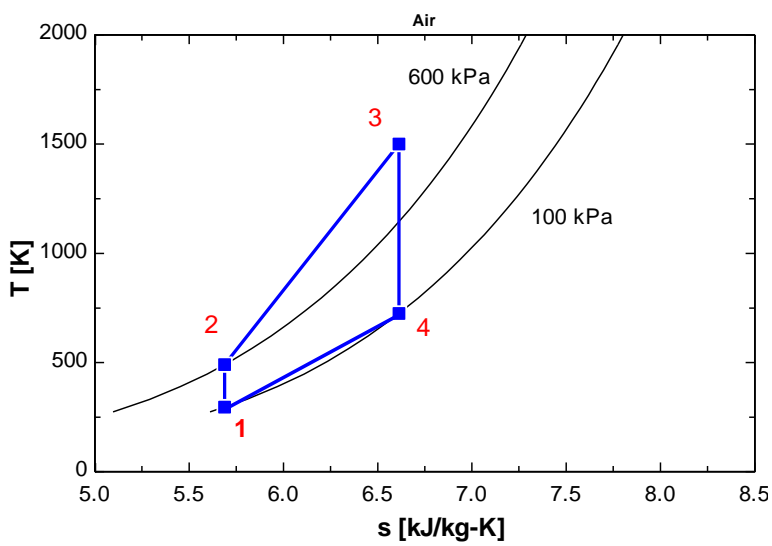
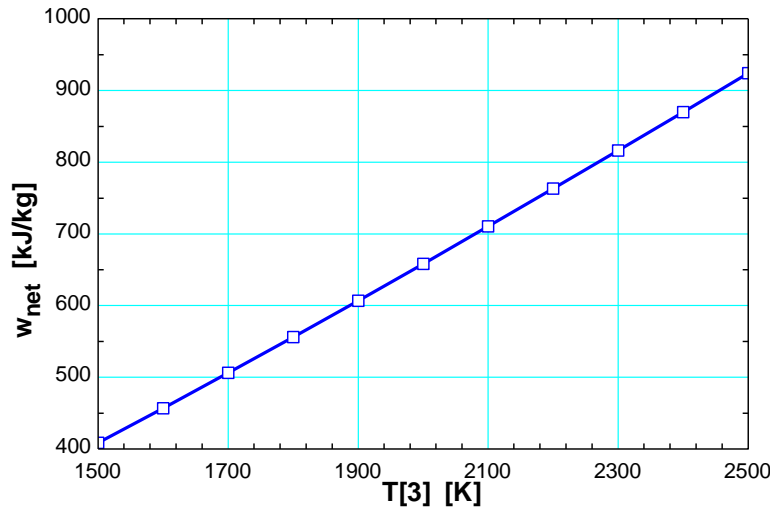

9-15 The three processes of an air-standard cycle are described. The cycle is to be shown on P - v and T - s diagrams, and the heat rejected and the thermal efficiency are to be determined.

Assumptions 1 The air-standard assumptions are applicable. **2** Kinetic and potential energy changes are negligible. **3** Air is an ideal gas with constant specific heats.

Properties The properties of air at room temperature are $c_p = 1.005 \text{ kJ/kg}\cdot\text{K}$, $c_v = 0.718 \text{ kJ/kg}\cdot\text{K}$, and $k = 1.4$ (Table A-2).

Analysis (b) The temperature at state 2 and the heat input are

$$T_2 = T_1 \left(\frac{P_2}{P_1} \right)^{(k-1)/k} = (300 \text{ K}) \left(\frac{1000 \text{ kPa}}{100 \text{ kPa}} \right)^{0.4/1.4} = 579.2 \text{ K}$$

$$Q_{\text{in}} = m(h_3 - h_2) = mc_p(T_3 - T_2)$$

$$416 \text{ kJ} = (0.5 \text{ kg})(1.005 \text{ kJ/kg}\cdot\text{K})(T_3 - 579.2) \longrightarrow T_3 = 1407.1 \text{ K}$$

Process 3-1 is a straight line on the P - v diagram, thus the w_{31} is simply the area under the process curve,

$$w_{31} = \text{area} = \frac{P_3 + P_1}{2} (v_1 - v_3) = \frac{P_3 + P_1}{2} \left(\frac{RT_1}{P_1} - \frac{RT_3}{P_3} \right)$$

$$= \left(\frac{1000 + 100 \text{ kPa}}{2} \right) \left(\frac{300 \text{ K}}{100 \text{ kPa}} - \frac{1407.1 \text{ K}}{1000 \text{ kPa}} \right) (0.287 \text{ kJ/kg}\cdot\text{K})$$

$$= 251.4 \text{ kJ/kg}$$

Energy balance for process 3-1 gives

$$E_{\text{in}} - E_{\text{out}} = \Delta E_{\text{system}} \longrightarrow -Q_{31,\text{out}} - W_{31,\text{out}} = m(u_1 - u_3)$$

$$Q_{31,\text{out}} = -mw_{31,\text{out}} - mc_v(T_1 - T_3) = -m[w_{31,\text{out}} + c_v(T_1 - T_3)]$$

$$= -(0.5 \text{ kg})[251.4 + (0.718 \text{ kJ/kg}\cdot\text{K})(300 - 1407.1)\text{K}]$$

$$= \mathbf{271.7 \text{ kJ}}$$

(c) The thermal efficiency is then

$$\eta_{\text{th}} = 1 - \frac{Q_{\text{out}}}{Q_{\text{in}}} = 1 - \frac{271.7 \text{ kJ}}{416 \text{ kJ}} = 0.347 = \mathbf{34.7\%}$$

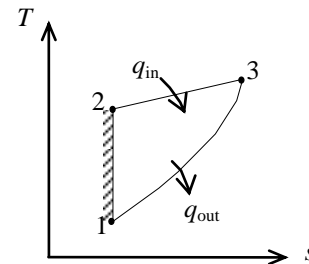
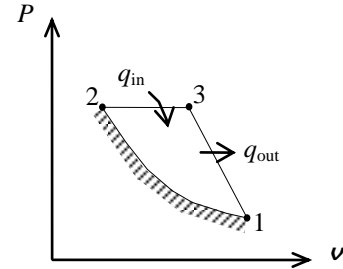

9-16E The four processes of an air-standard cycle are described. The cycle is to be shown on P - v and T - s diagrams, and the total heat input and the thermal efficiency are to be determined.

Assumptions 1 The air-standard assumptions are applicable. **2** Kinetic and potential energy changes are negligible. **3** Air is an ideal gas with variable specific heats.

Properties The properties of air are given in Table A-17E.

Analysis (b) The properties of air at various states are

$$T_1 = 540 \text{ R} \longrightarrow u_1 = 92.04 \text{ Btu/lbm}, \quad h_1 = 129.06 \text{ Btu/lbm}$$

$$q_{\text{in},12} = u_2 - u_1 \longrightarrow u_2 = u_1 + q_{\text{in},12} = 92.04 + 300 = 392.04 \text{ Btu/lbm}$$

$$T_2 = 2116 \text{ R}, \quad h_2 = 537.1 \text{ Btu/lbm}$$

$$\frac{P_2 v_2}{T_2} = \frac{P_1 v_1}{T_1} \longrightarrow P_2 = \frac{T_2}{T_1} P_1 = \frac{2116 \text{ R}}{540 \text{ R}} (14.7 \text{ psia}) = 57.6 \text{ psia}$$

$$T_3 = 3200 \text{ R} \longrightarrow h_3 = 849.48 \text{ Btu/lbm}$$

$$P_{r_3} = 1242$$

$$P_{r_4} = \frac{P_4}{P_3} P_{r_3} = \frac{14.7 \text{ psia}}{57.6 \text{ psia}} (1242) = 317.0 \longrightarrow h_4 = 593.22 \text{ Btu/lbm}$$

From energy balance,

$$q_{23,\text{in}} = h_3 - h_2 = 849.48 - 537.1 = 312.38 \text{ Btu/lbm}$$

$$q_{\text{in}} = q_{12,\text{in}} + q_{23,\text{in}} = 300 + 312.38 = \mathbf{612.38 \text{ Btu/lbm}}$$

$$q_{\text{out}} = h_4 - h_1 = 593.22 - 129.06 = 464.16 \text{ Btu/lbm}$$

(c) Then the thermal efficiency becomes

$$\eta_{\text{th}} = 1 - \frac{q_{\text{out}}}{q_{\text{in}}} = 1 - \frac{464.16 \text{ Btu/lbm}}{612.38 \text{ Btu/lbm}} = \mathbf{24.2\%}$$

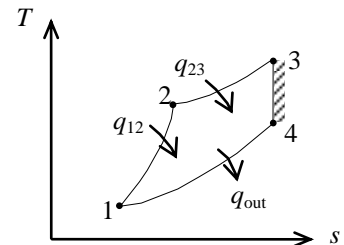
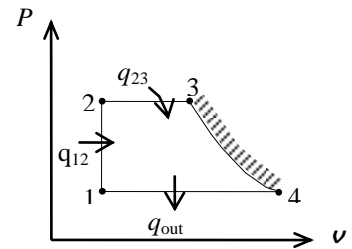

9-17E The four processes of an air-standard cycle are described. The cycle is to be shown on P - v and T - s diagrams, and the total heat input and the thermal efficiency are to be determined.

Assumptions 1 The air-standard assumptions are applicable. **2** Kinetic and potential energy changes are negligible. **3** Air is an ideal gas with constant specific heats.

Properties The properties of air at room temperature are $c_p = 0.240$ Btu/lbm·R, $c_v = 0.171$ Btu/lbm·R, and $k = 1.4$ (Table A-2E).

Analysis (b) The temperature at state 2 and the heat input are

$$q_{in,12} = u_2 - u_1 = c_v(T_2 - T_1)$$

$$300 \text{ Btu/lbm} = (0.171 \text{ Btu/lbm}\cdot\text{R})(T_2 - 540)\text{R}$$

$$T_2 = 2294 \text{ R}$$

$$\frac{P_2 v_2}{T_2} = \frac{P_1 v_1}{T_1} \longrightarrow P_2 = \frac{T_2}{T_1} P_1 = \frac{2294 \text{ R}}{540 \text{ R}} (14.7 \text{ psia}) = 62.46 \text{ psia}$$

$$q_{in,23} = h_3 - h_2 = c_p(T_3 - T_2) = (0.24 \text{ Btu/lbm}\cdot\text{R})(3200 - 2294)\text{R} = 217.4 \text{ Btu/lbm}$$

Process 3-4 is isentropic:

$$T_4 = T_3 \left(\frac{P_4}{P_3} \right)^{(k-1)/k} = (3200 \text{ R}) \left(\frac{14.7 \text{ psia}}{62.46 \text{ psia}} \right)^{0.4/1.4} = 2117 \text{ R}$$

$$q_{in} = q_{in,12} + q_{in,23} = 300 + 217.4 = \mathbf{517.4 \text{ Btu/lbm}}$$

$$q_{out} = h_4 - h_1 = c_p(T_4 - T_1) = (0.240 \text{ Btu/lbm}\cdot\text{R})(2117 - 540) = 378.5 \text{ Btu/lbm}$$

(c) The thermal efficiency is then

$$\eta_{th} = 1 - \frac{q_{out}}{q_{in}} = 1 - \frac{378.5 \text{ Btu/lbm}}{517.4 \text{ Btu/lbm}} = \mathbf{26.8\%}$$

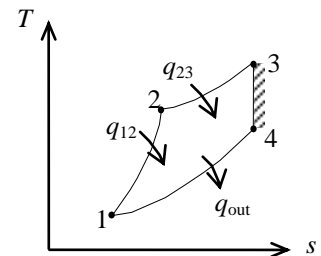
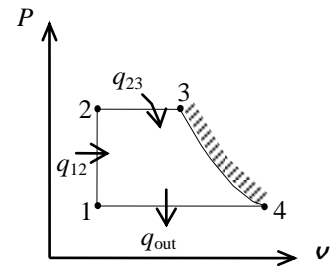

9-18 A Carnot cycle with specified temperature limits is considered. The maximum pressure in the cycle, the heat transfer to the working fluid, and the mass of the working fluid are to be determined.

Assumptions Air is an ideal gas with variable specific heats.

Analysis (a) In a Carnot cycle, the maximum pressure occurs at the beginning of the expansion process, which is state 1.

$$T_1 = 1200 \text{ K} \quad \longrightarrow \quad P_{r_1} = 238 \quad (\text{Table A-17})$$

$$T_4 = 350 \text{ K} \quad \longrightarrow \quad P_{r_4} = 2.379$$

$$P_1 = \frac{P_{r_1}}{P_{r_4}} P_4 = \frac{238}{2.379} (300 \text{ kPa}) = 30,013 \text{ kPa} \cong \mathbf{30.0 \text{ MPa}} = P_{\max}$$

(b) The heat input is determined from

$$\eta_{\text{th}} = 1 - \frac{T_L}{T_H} = 1 - \frac{350 \text{ K}}{1200 \text{ K}} = 70.83\%$$

$$Q_{\text{in}} = W_{\text{net,out}} / \eta_{\text{th}} = (0.5 \text{ kJ}) / (0.7083) = \mathbf{0.706 \text{ kJ}}$$

(c) The mass of air is

$$s_4 - s_3 = (s_4^\circ - s_3^\circ)^{\phi_0} - R \ln \frac{P_4}{P_3} = -(0.287 \text{ kJ/kg} \cdot \text{K}) \ln \frac{300 \text{ kPa}}{150 \text{ kPa}}$$

$$= -0.199 \text{ kJ/kg} \cdot \text{K} = s_1 - s_2$$

$$w_{\text{net,out}} = (s_2 - s_1)(T_H - T_L) = (0.199 \text{ kJ/kg} \cdot \text{K})(1200 - 350) \text{ K} = 169.15 \text{ kJ/kg}$$

$$m = \frac{W_{\text{net,out}}}{w_{\text{net,out}}} = \frac{0.5 \text{ kJ}}{169.15 \text{ kJ/kg}} = \mathbf{0.00296 \text{ kg}}$$

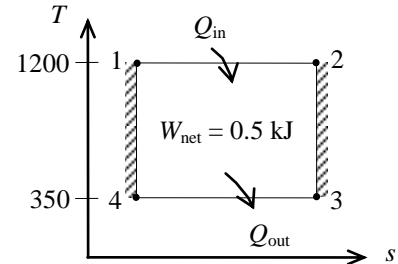

9-19 A Carnot cycle with specified temperature limits is considered. The maximum pressure in the cycle, the heat transfer to the working fluid, and the mass of the working fluid are to be determined.

Assumptions Helium is an ideal gas with constant specific heats.

Properties The properties of helium at room temperature are $R = 2.0769 \text{ kJ/kg}\cdot\text{K}$ and $k = 1.667$ (Table A-2).

Analysis (a) In a Carnot cycle, the maximum pressure occurs at the beginning of the expansion process, which is state 1.

$$\frac{T_1}{T_4} = \left(\frac{P_1}{P_4} \right)^{(k-1)/k}$$

or,

$$P_1 = P_4 \left(\frac{T_1}{T_4} \right)^{k/(k-1)} = (300 \text{ kPa}) \left(\frac{1200 \text{ K}}{350 \text{ K}} \right)^{1.667/0.667} = \mathbf{6524 \text{ kPa}}$$

(b) The heat input is determined from

$$\eta_{\text{th}} = 1 - \frac{T_L}{T_H} = 1 - \frac{350 \text{ K}}{1200 \text{ K}} = 70.83\%$$

$$Q_{\text{in}} = W_{\text{net,out}} / \eta_{\text{th}} = (0.5 \text{ kJ}) / (0.7083) = \mathbf{0.706 \text{ kJ}}$$

(c) The mass of helium is determined from

$$s_4 - s_3 = c_p \ln \frac{T_4}{T_3} - R \ln \frac{P_4}{P_3} = -(2.0769 \text{ kJ/kg}\cdot\text{K}) \ln \frac{300 \text{ kPa}}{150 \text{ kPa}}$$

$$= -1.4396 \text{ kJ/kg}\cdot\text{K} = s_1 - s_2$$

$$w_{\text{net,out}} = (s_2 - s_1)(T_H - T_L) = (1.4396 \text{ kJ/kg}\cdot\text{K})(1200 - 350) \text{ K} = 1223.7 \text{ kJ/kg}$$

$$m = \frac{W_{\text{net,out}}}{w_{\text{net,out}}} = \frac{0.5 \text{ kJ}}{1223.7 \text{ kJ/kg}} = \mathbf{0.000409 \text{ kg}}$$

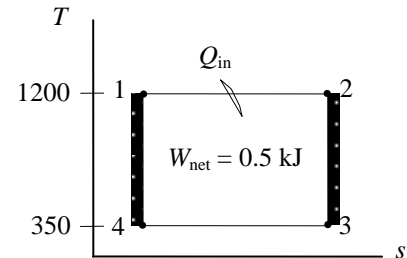

9-20 A Carnot cycle with the specified temperature limits is considered. The net work output per cycle is to be determined.

Assumptions Air is an ideal gas with constant specific heats.

Properties The properties of air at room temperature are $c_p = 1.005 \text{ kJ/kg}\cdot\text{K}$, $c_v = 0.718 \text{ kJ/kg}\cdot\text{K}$, $R = 0.287 \text{ kJ/kg}\cdot\text{K}$, and $k = 1.4$ (Table A-2).

Analysis The minimum pressure in the cycle is P_3 and the maximum pressure is P_1 . Then,

$$\frac{T_2}{T_3} = \left(\frac{P_2}{P_3} \right)^{(k-1)/k}$$

or

$$P_2 = P_3 \left(\frac{T_2}{T_3} \right)^{k/(k-1)} = (20 \text{ kPa}) \left(\frac{1100 \text{ K}}{300 \text{ K}} \right)^{1.4/0.4} = 1888 \text{ kPa}$$

The heat input is determined from

$$s_2 - s_1 = c_p \ln \frac{T_2}{T_1} - R \ln \frac{P_2}{P_1} = -(0.287 \text{ kJ/kg}\cdot\text{K}) \ln \frac{1888 \text{ kPa}}{3000 \text{ kPa}} = 0.1329 \text{ kJ/kg}\cdot\text{K}$$

$$Q_{\text{in}} = mT_H(s_2 - s_1) = (0.6 \text{ kg})(1100 \text{ K})(0.1329 \text{ kJ/kg}\cdot\text{K}) = 87.73 \text{ kJ}$$

Then,

$$\eta_{\text{th}} = 1 - \frac{T_L}{T_H} = 1 - \frac{300 \text{ K}}{1100 \text{ K}} = 0.7273 = 72.7\%$$

$$W_{\text{net,out}} = \eta_{\text{th}} Q_{\text{in}} = (0.7273)(87.73 \text{ kJ}) = \mathbf{63.8 \text{ kJ}}$$

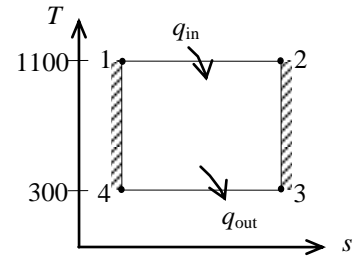

9-21 A Carnot cycle executed in a closed system with air as the working fluid is considered. The minimum pressure in the cycle, the heat rejection from the cycle, the thermal efficiency of the cycle, and the second-law efficiency of an actual cycle operating between the same temperature limits are to be determined.

Assumptions Air is an ideal gas with constant specific heats.

Properties The properties of air at room temperatures are $R = 0.287 \text{ kJ/kg}\cdot\text{K}$ and $k = 1.4$ (Table A-2).

Analysis (a) The minimum temperature is determined from

$$w_{\text{net}} = (s_2 - s_1)(T_H - T_L) \longrightarrow 100 \text{ kJ/kg} = (0.25 \text{ kJ/kg}\cdot\text{K})(950 - T_L)\text{K} \longrightarrow T_L = 550 \text{ K}$$

The pressure at state 4 is determined from

$$\frac{T_1}{T_4} = \left(\frac{P_1}{P_4}\right)^{(k-1)/k}$$

or

$$P_1 = P_4 \left(\frac{T_1}{T_4}\right)^{k/(k-1)}$$

$$1300 \text{ kPa} = P_4 \left(\frac{950 \text{ K}}{550 \text{ K}}\right)^{1.4/0.4} \longrightarrow P_4 = 241.9 \text{ kPa}$$

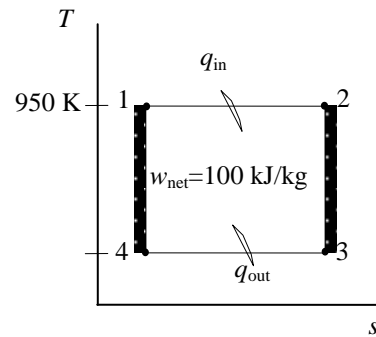

The minimum pressure in the cycle is determined from

$$\begin{aligned} \Delta s_{12} = -\Delta s_{34} &= c_p \ln \frac{T_4}{T_3} - R \ln \frac{P_4}{P_3} \\ -0.25 \text{ kJ/kg}\cdot\text{K} &= -(0.287 \text{ kJ/kg}\cdot\text{K}) \ln \frac{241.9 \text{ kPa}}{P_3} \longrightarrow P_3 = \mathbf{101.2 \text{ kPa}} \end{aligned}$$

(b) The heat rejection from the cycle is

$$q_{\text{out}} = T_L \Delta s_{12} = (550 \text{ K})(0.25 \text{ kJ/kg}\cdot\text{K}) = \mathbf{137.5 \text{ kJ/kg}}$$

(c) The thermal efficiency is determined from

$$\eta_{\text{th}} = 1 - \frac{T_L}{T_H} = 1 - \frac{550 \text{ K}}{950 \text{ K}} = 0.421 = \mathbf{42.1\%}$$

(d) The power output for the Carnot cycle is

$$\dot{W}_{\text{Carnot}} = \dot{m}w_{\text{net}} = (95 \text{ kg/s})(100 \text{ kJ/kg}) = 9500 \text{ kW}$$

Then, the second-law efficiency of the actual cycle becomes

$$\eta_{\text{II}} = \frac{\dot{W}_{\text{actual}}}{\dot{W}_{\text{Carnot}}} = \frac{5200 \text{ kW}}{9500 \text{ kW}} = 0.547 = \mathbf{54.7\%}$$

9-22 An air-standard cycle executed in a piston-cylinder system is composed of three specified processes. The cycle is to be sketched on the P - v and T - s diagrams; the heat and work interactions and the thermal efficiency of the cycle are to be determined; and an expression for thermal efficiency as functions of compression ratio and specific heat ratio is to be obtained.

Assumptions 1 The air-standard assumptions are applicable. **2** Kinetic and potential energy changes are negligible. **3** Air is an ideal gas with constant specific heats.

Properties The properties of air are given as $R = 0.3 \text{ kJ/kg}\cdot\text{K}$ and $c_v = 0.7 \text{ kJ/kg}\cdot\text{K}$.

Analysis (a) The P - v and T - s diagrams of the cycle are shown in the figures.

(b) Noting that

$$c_p = c_v + R = 0.7 + 0.3 = 1.0 \text{ kJ/kg}\cdot\text{K}$$

$$k = \frac{c_p}{c_v} = \frac{1.0}{0.7} = 1.429$$

Process 1-2: Isentropic compression

$$T_2 = T_1 \left(\frac{v_1}{v_2} \right)^{k-1} = T_1 r^{k-1} = (293 \text{ K})(5)^{0.429} = 584.4 \text{ K}$$

$$w_{1-2,\text{in}} = c_v(T_2 - T_1) = (0.7 \text{ kJ/kg}\cdot\text{K})(584.4 - 293) \text{ K} = \mathbf{204.0 \text{ kJ/kg}}$$

$$q_{1-2} = \mathbf{0}$$

From ideal gas relation,

$$\frac{T_3}{T_2} = \frac{v_3}{v_2} = \frac{v_1}{v_2} = r \longrightarrow T_3 = (584.4)(5) = 2922$$

Process 2-3: Constant pressure heat addition

$$\begin{aligned} w_{2-3,\text{out}} &= \int_2^3 P d v = P_2(v_3 - v_2) = R(T_3 - T_2) \\ &= (0.3 \text{ kJ/kg}\cdot\text{K})(2922 - 584.4) \text{ K} = \mathbf{701.3 \text{ kJ/kg}} \end{aligned}$$

$$\begin{aligned} q_{2-3,\text{in}} &= w_{2-3,\text{out}} + \Delta u_{2-3} = \Delta h_{2-3} \\ &= c_p(T_3 - T_2) = (1 \text{ kJ/kg}\cdot\text{K})(2922 - 584.4) \text{ K} = \mathbf{2338 \text{ kJ/kg}} \end{aligned}$$

Process 3-1: Constant volume heat rejection

$$q_{3-1,\text{out}} = \Delta u_{1-3} = c_v(T_3 - T_1) = (0.7 \text{ kJ/kg}\cdot\text{K})(2922 - 293) \text{ K} = \mathbf{1840.3 \text{ kJ/kg}}$$

$$w_{3-1} = \mathbf{0}$$

(c) Net work is

$$w_{\text{net}} = w_{2-3,\text{out}} - w_{1-2,\text{in}} = 701.3 - 204.0 = 497.3 \text{ kJ/kg}\cdot\text{K}$$

The thermal efficiency is then

$$\eta_{\text{th}} = \frac{w_{\text{net}}}{q_{\text{in}}} = \frac{497.3 \text{ kJ}}{2338 \text{ kJ}} = 0.213 = \mathbf{21.3\%}$$

(d) The expression for the cycle thermal efficiency is obtained as follows:

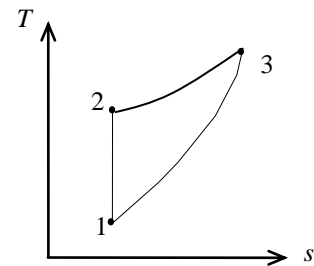
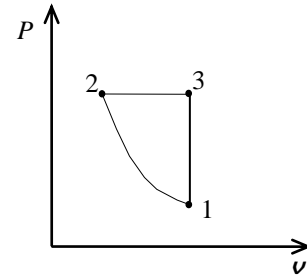

$$\begin{aligned}
\eta_{\text{th}} &= \frac{W_{\text{net}}}{q_{\text{in}}} = \frac{W_{2-3,\text{out}} - W_{1-2,\text{in}}}{q_{\text{in}}} \\
&= \frac{R(T_3 - T_2) - c_v(T_2 - T_1)}{c_p(T_3 - T_2)} \\
&= \frac{R}{c_p} - \frac{c_v(T_1 r^{k-1} - T_1)}{c_p(rT_1 r^{k-1} - T_1 r^{k-1})} \\
&= \frac{R}{c_p} - \frac{c_v T_1 r^{k-1} \left(1 - \frac{T_1}{T_1 r^{k-1}}\right)}{c_p T_1 r^{k-1} (r - 1)} \\
&= \frac{R}{c_p} - \frac{1}{k(r-1)} \left(1 - \frac{T_1}{T_1 r^{k-1}}\right) \\
&= \frac{R}{c_p} - \frac{1}{k(r-1)} \left(1 - \frac{1}{r^{k-1}}\right) \\
&= \left(1 - \frac{1}{k}\right) - \frac{1}{k(r-1)} \left(1 - \frac{1}{r^{k-1}}\right)
\end{aligned}$$

since

$$\frac{R}{c_p} = \frac{c_p - c_v}{c_p} = 1 - \frac{c_v}{c_p} = 1 - \frac{1}{k}$$

Otto Cycle

9-23C The four processes that make up the Otto cycle are (1) isentropic compression, (2) $v = \text{constant}$ heat addition, (3) isentropic expansion, and (4) $v = \text{constant}$ heat rejection.

9-24C They are analyzed as closed system processes because no mass crosses the system boundaries during any of the processes.

9-25C The ideal Otto cycle involves external irreversibilities, and thus it has a lower thermal efficiency.

9-26C It increases with both of them.

9-27C For actual four-stroke engines, the rpm is twice the number of thermodynamic cycles; for two-stroke engines, it is equal to the number of thermodynamic cycles.

9-28C Because high compression ratios cause engine knock.

9-29C The thermal efficiency will be the highest for argon because it has the highest specific heat ratio, $k = 1.667$.

9-30C The fuel is injected into the cylinder in both engines, but it is ignited with a spark plug in gasoline engines.

9-31 An ideal Otto cycle is considered. The thermal efficiency and the rate of heat input are to be determined.

Assumptions 1 The air-standard assumptions are applicable. 2 Kinetic and potential energy changes are negligible. 3 Air is an ideal gas with constant specific heats.

Properties The properties of air at room temperature are $c_p = 1.005 \text{ kJ/kg}\cdot\text{K}$, $c_v = 0.718 \text{ kJ/kg}\cdot\text{K}$, and $k = 1.4$ (Table A-2a).

Analysis The definition of cycle thermal efficiency reduces to

$$\eta_{\text{th}} = 1 - \frac{1}{r^{k-1}} = 1 - \frac{1}{10.5^{1.4-1}} = 0.6096 = \mathbf{61.0\%}$$

The rate of heat addition is then

$$\dot{Q}_{\text{in}} = \frac{\dot{W}_{\text{net}}}{\eta_{\text{th}}} = \frac{90 \text{ kW}}{0.6096} = \mathbf{148 \text{ kW}}$$

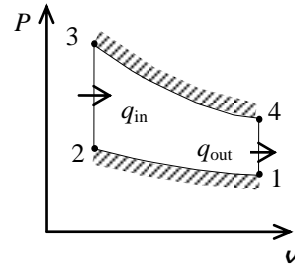

9-32 An ideal Otto cycle is considered. The thermal efficiency and the rate of heat input are to be determined.

Assumptions 1 The air-standard assumptions are applicable. 2 Kinetic and potential energy changes are negligible. 3 Air is an ideal gas with constant specific heats.

Properties The properties of air at room temperature are $c_p = 1.005 \text{ kJ/kg}\cdot\text{K}$, $c_v = 0.718 \text{ kJ/kg}\cdot\text{K}$, and $k = 1.4$ (Table A-2a).

Analysis The definition of cycle thermal efficiency reduces to

$$\eta_{\text{th}} = 1 - \frac{1}{r^{k-1}} = 1 - \frac{1}{8.5^{1.4-1}} = 0.5752 = \mathbf{57.5\%}$$

The rate of heat addition is then

$$\dot{Q}_{\text{in}} = \frac{\dot{W}_{\text{net}}}{\eta_{\text{th}}} = \frac{90 \text{ kW}}{0.5752} = \mathbf{157 \text{ kW}}$$

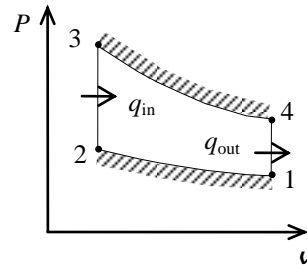

9-33 An ideal Otto cycle with air as the working fluid has a compression ratio of 8. The pressure and temperature at the end of the heat addition process, the net work output, the thermal efficiency, and the mean effective pressure for the cycle are to be determined.

Assumptions 1 The air-standard assumptions are applicable. **2** Kinetic and potential energy changes are negligible. **3** Air is an ideal gas with variable specific heats.

Properties The gas constant of air is $R = 0.287 \text{ kJ/kg}\cdot\text{K}$. The properties of air are given in Table A-17.

Analysis (a) Process 1-2: isentropic compression.

$$T_1 = 300\text{K} \longrightarrow \begin{array}{l} u_1 = 214.07\text{kJ/kg} \\ \nu_{r_1} = 621.2 \end{array}$$

$$\nu_{r_2} = \frac{\nu_2}{\nu_1} \nu_{r_1} = \frac{1}{r} \nu_{r_1} = \frac{1}{8}(621.2) = 77.65 \longrightarrow \begin{array}{l} T_2 = 673.1\text{K} \\ u_2 = 491.2\text{kJ/kg} \end{array}$$

$$\frac{P_2 \nu_2}{T_2} = \frac{P_1 \nu_1}{T_1} \longrightarrow P_2 = \frac{\nu_1}{\nu_2} \frac{T_2}{T_1} P_1 = (8) \left(\frac{673.1\text{K}}{300\text{K}} \right) (95\text{ kPa}) = 1705\text{ kPa}$$

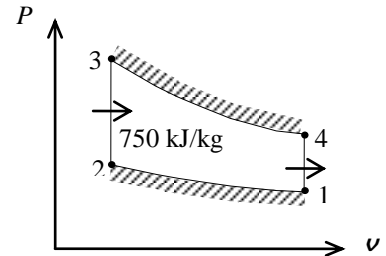

Process 2-3: $\nu = \text{constant}$ heat addition.

$$q_{23,\text{in}} = u_3 - u_2 \longrightarrow u_3 = u_2 + q_{23,\text{in}} = 491.2 + 750 = 1241.2\text{ kJ/kg} \longrightarrow \begin{array}{l} T_3 = 1539\text{K} \\ \nu_{r_3} = 6.588 \end{array}$$

$$\frac{P_3 \nu_3}{T_3} = \frac{P_2 \nu_2}{T_2} \longrightarrow P_3 = \frac{T_3}{T_2} P_2 = \left(\frac{1539\text{K}}{673.1\text{K}} \right) (1705\text{ kPa}) = 3898\text{ kPa}$$

(b) Process 3-4: isentropic expansion.

$$\nu_{r_4} = \frac{\nu_4}{\nu_3} \nu_{r_3} = r \nu_{r_3} = (8)(6.588) = 52.70 \longrightarrow \begin{array}{l} T_4 = 774.5\text{K} \\ u_4 = 571.69\text{kJ/kg} \end{array}$$

Process 4-1: $\nu = \text{constant}$ heat rejection.

$$q_{\text{out}} = u_4 - u_1 = 571.69 - 214.07 = 357.62\text{ kJ/kg}$$

$$w_{\text{net,out}} = q_{\text{in}} - q_{\text{out}} = 750 - 357.62 = 392.4\text{ kJ/kg}$$

$$(c) \quad \eta_{\text{th}} = \frac{w_{\text{net,out}}}{q_{\text{in}}} = \frac{392.4\text{ kJ/kg}}{750\text{ kJ/kg}} = 52.3\%$$

$$(d) \quad \nu_1 = \frac{RT_1}{P_1} = \frac{(0.287\text{ kPa}\cdot\text{m}^3/\text{kg}\cdot\text{K})(300\text{K})}{95\text{ kPa}} = 0.906\text{ m}^3/\text{kg} = \nu_{\text{max}}$$

$$\nu_{\text{min}} = \nu_2 = \frac{\nu_{\text{max}}}{r}$$

$$\text{MEP} = \frac{w_{\text{net,out}}}{\nu_1 - \nu_2} = \frac{w_{\text{net,out}}}{\nu_1(1 - 1/r)} = \frac{392.4\text{ kJ/kg}}{(0.906\text{ m}^3/\text{kg})(1 - 1/8)} \left(\frac{\text{kPa}\cdot\text{m}^3}{\text{kJ}} \right) = 495.0\text{ kPa}$$



9-34 Problem 9-33 is reconsidered. The effect of the compression ratio on the net work output and thermal efficiency is to be investigated. Also, T - s and P - v diagrams for the cycle are to be plotted.

Analysis Using EES, the problem is solved as follows:

"Input Data"

T[1]=300 [K]
 P[1]=95 [kPa]
 q_23 = 750 [kJ/kg]
 {r_comp = 8}

"Process 1-2 is isentropic compression"

s[1]=entropy(air,T=T[1],P=P[1])
 s[2]=s[1]
 T[2]=temperature(air, s=s[2], P=P[2])
 P[2]*v[2]/T[2]=P[1]*v[1]/T[1]
 P[1]*v[1]=R*T[1]
 R=0.287 [kJ/kg-K]
 V[2] = V[1]/ r_comp

"Conservation of energy for process 1 to 2"

q_12 - w_12 = DELTAu_12
 q_12 =0"isentropic process"
 DELTAu_12=intenergy(air,T=T[2])-intenergy(air,T=T[1])

"Process 2-3 is constant volume heat addition"

v[3]=v[2]
 s[3]=entropy(air, T=T[3], P=P[3])
 P[3]*v[3]=R*T[3]

"Conservation of energy for process 2 to 3"

q_23 - w_23 = DELTAu_23
 w_23 =0"constant volume process"
 DELTAu_23=intenergy(air,T=T[3])-intenergy(air,T=T[2])

"Process 3-4 is isentropic expansion"

s[4]=s[3]
 s[4]=entropy(air,T=T[4],P=P[4])
 P[4]*v[4]=R*T[4]

"Conservation of energy for process 3 to 4"

q_34 -w_34 = DELTAu_34
 q_34 =0"isentropic process"
 DELTAu_34=intenergy(air,T=T[4])-intenergy(air,T=T[3])

"Process 4-1 is constant volume heat rejection"

V[4] = V[1]
 "Conservation of energy for process 4 to 1"
 q_41 - w_41 = DELTAu_41
 w_41 =0 "constant volume process"
 DELTAu_41=intenergy(air,T=T[1])-intenergy(air,T=T[4])

q_in_total=q_23
 q_out_total = -q_41
 w_net = w_12+w_23+w_34+w_41
 Eta_th=w_net/q_in_total*100 "Thermal efficiency, in percent"
 "The mean effective pressure is:"
 MEP = w_net/(V[1]-V[2])" [kPa]"

r_{comp}	η_{th}	MEP [kPa]	w_{net} [kJ/kg]
5	43.78	452.9	328.4
6	47.29	469.6	354.7
7	50.08	483.5	375.6
8	52.36	495.2	392.7
9	54.28	505.3	407.1
10	55.93	514.2	419.5

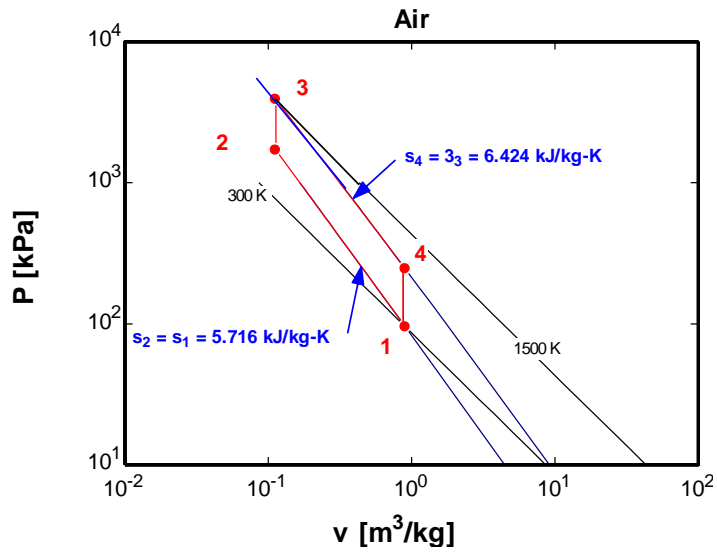
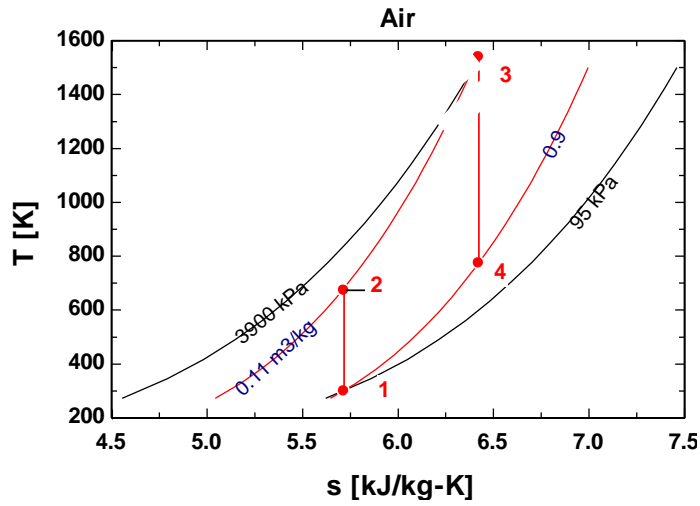

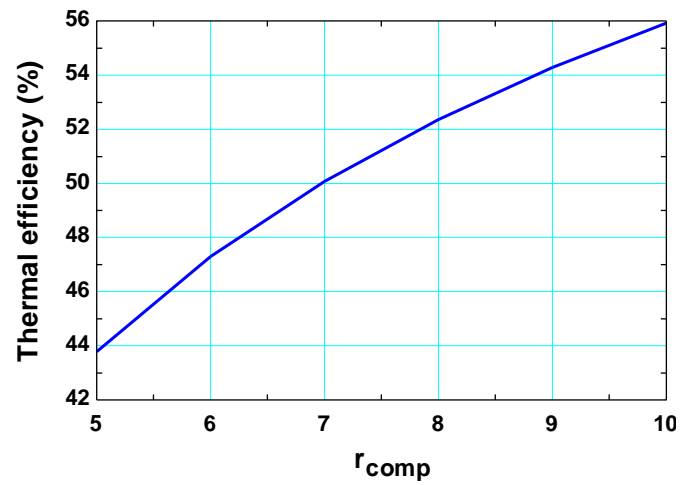
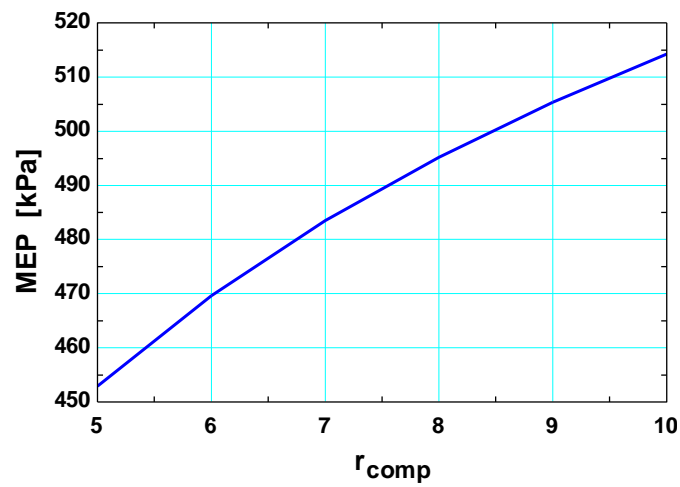
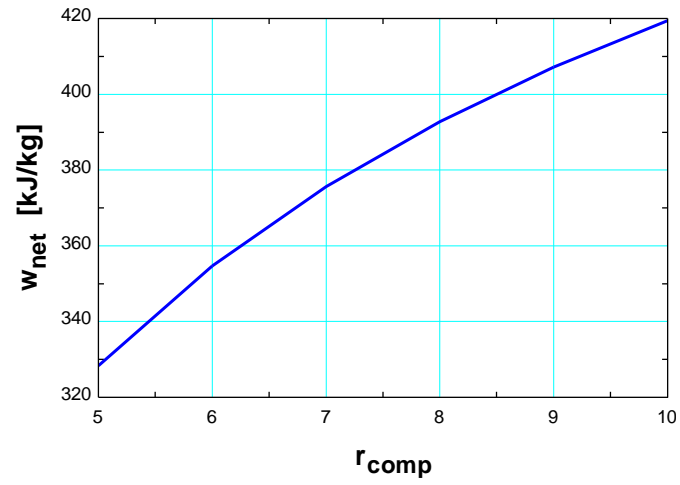

9-35 An ideal Otto cycle with air as the working fluid has a compression ratio of 8. The pressure and temperature at the end of the heat addition process, the net work output, the thermal efficiency, and the mean effective pressure for the cycle are to be determined.

Assumptions 1 The air-standard assumptions are applicable. **2** Kinetic and potential energy changes are negligible. **3** Air is an ideal gas with constant specific heats.

Properties The properties of air at room temperature are $c_p = 1.005 \text{ kJ/kg}\cdot\text{K}$, $c_v = 0.718 \text{ kJ/kg}\cdot\text{K}$, $R = 0.287 \text{ kJ/kg}\cdot\text{K}$, and $k = 1.4$ (Table A-2).

Analysis (a) Process 1-2: isentropic compression.

$$T_2 = T_1 \left(\frac{\nu_1}{\nu_2} \right)^{k-1} = (300 \text{ K})(8)^{0.4} = 689 \text{ K}$$

$$\frac{P_2 \nu_2}{T_2} = \frac{P_1 \nu_1}{T_1} \longrightarrow P_2 = \frac{\nu_1}{\nu_2} \frac{T_2}{T_1} P_1 = (8) \left(\frac{689 \text{ K}}{300 \text{ K}} \right) (95 \text{ kPa}) = 1745 \text{ kPa}$$

Process 2-3: $\nu = \text{constant}$ heat addition.

$$q_{23,\text{in}} = u_3 - u_2 = c_v (T_3 - T_2)$$

$$750 \text{ kJ/kg} = (0.718 \text{ kJ/kg}\cdot\text{K})(T_3 - 689 \text{ K})$$

$$T_3 = \mathbf{1734 \text{ K}}$$

$$\frac{P_3 \nu_3}{T_3} = \frac{P_2 \nu_2}{T_2} \longrightarrow P_3 = \frac{T_3}{T_2} P_2 = \left(\frac{1734 \text{ K}}{689 \text{ K}} \right) (1745 \text{ kPa}) = \mathbf{4392 \text{ kPa}}$$

(b) Process 3-4: isentropic expansion.

$$T_4 = T_3 \left(\frac{\nu_3}{\nu_4} \right)^{k-1} = (1734 \text{ K}) \left(\frac{1}{8} \right)^{0.4} = 755 \text{ K}$$

Process 4-1: $\nu = \text{constant}$ heat rejection.

$$q_{\text{out}} = u_4 - u_1 = c_v (T_4 - T_1) = (0.718 \text{ kJ/kg}\cdot\text{K})(755 - 300) \text{ K} = 327 \text{ kJ/kg}$$

$$w_{\text{net,out}} = q_{\text{in}} - q_{\text{out}} = 750 - 327 = \mathbf{423 \text{ kJ/kg}}$$

$$(c) \quad \eta_{\text{th}} = \frac{w_{\text{net,out}}}{q_{\text{in}}} = \frac{423 \text{ kJ/kg}}{750 \text{ kJ/kg}} = \mathbf{56.4\%}$$

$$(d) \quad \nu_1 = \frac{RT_1}{P_1} = \frac{(0.287 \text{ kPa}\cdot\text{m}^3/\text{kg}\cdot\text{K})(300 \text{ K})}{95 \text{ kPa}} = 0.906 \text{ m}^3/\text{kg} = \nu_{\text{max}}$$

$$\nu_{\text{min}} = \nu_2 = \frac{\nu_{\text{max}}}{r}$$

$$\text{MEP} = \frac{w_{\text{net,out}}}{\nu_1 - \nu_2} = \frac{w_{\text{net,out}}}{\nu_1 (1 - 1/r)} = \frac{423 \text{ kJ/kg}}{(0.906 \text{ m}^3/\text{kg})(1 - 1/8)} \left(\frac{\text{kPa}\cdot\text{m}^3}{\text{kJ}} \right) = \mathbf{534 \text{ kPa}}$$

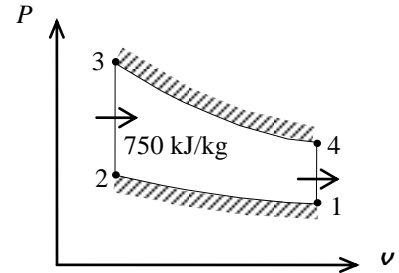

9-36E A six-cylinder, four-stroke, spark-ignition engine operating on the ideal Otto cycle is considered. The power produced by the engine is to be determined.

Assumptions 1 The air-standard assumptions are applicable. **2** Kinetic and potential energy changes are negligible. **3** Air is an ideal gas with constant specific heats.

Properties The properties of air at room temperature are $R = 0.3704 \text{ psia} \cdot \text{ft}^3/\text{lbm} \cdot \text{R}$ (Table A-1E), $c_p = 0.240 \text{ Btu}/\text{lbm} \cdot \text{R}$, $c_v = 0.171 \text{ Btu}/\text{lbm} \cdot \text{R}$, and $k = 1.4$ (Table A-2Ea).

Analysis From the data specified in the problem statement,

$$r = \frac{v_1}{v_2} = \frac{v_1}{0.098v_1} = 10.20$$

Since the compression and expansion processes are isentropic,

$$T_2 = T_1 \left(\frac{v_1}{v_2} \right)^{k-1} = T_1 r^{k-1} = (565 \text{ R})(10.20)^{1.4-1} = 1430.7 \text{ R}$$

$$T_4 = T_3 \left(\frac{v_3}{v_4} \right)^{k-1} = T_3 \left(\frac{1}{r} \right)^{k-1} = (2860 \text{ R}) \left(\frac{1}{10.20} \right)^{1.4-1} = 1129.4 \text{ R}$$

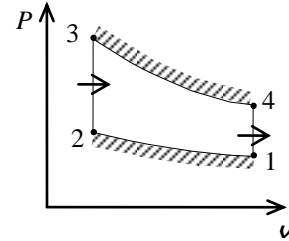

Application of the first law to the compression and expansion processes gives

$$\begin{aligned} w_{\text{net}} &= c_v(T_3 - T_4) - c_v(T_2 - T_1) \\ &= (0.171 \text{ Btu}/\text{lbm} \cdot \text{R})(2860 - 1129.4) \text{ R} - (0.171 \text{ Btu}/\text{lbm} \cdot \text{R})(1430.7 - 565) \text{ R} \\ &= 147.9 \text{ Btu}/\text{lbm} \end{aligned}$$

When each cylinder is charged with the air-fuel mixture,

$$v_1 = \frac{RT_1}{P_1} = \frac{(0.3704 \text{ psia} \cdot \text{ft}^3/\text{lbm} \cdot \text{R})(565 \text{ R})}{14 \text{ psia}} = 14.95 \text{ ft}^3/\text{lbm}$$

The total air mass taken by all 6 cylinders when they are charged is

$$m = N_{\text{cyl}} \frac{\Delta V}{v_1} = N_{\text{cyl}} \frac{\pi B^2 S / 4}{v_1} = (6) \frac{\pi (3.5/12 \text{ ft})^2 (3.9/12 \text{ ft}) / 4}{14.95 \text{ ft}^3/\text{lbm}} = 0.008716 \text{ lbm}$$

The net work produced per cycle is

$$W_{\text{net}} = mw_{\text{net}} = (0.008716 \text{ lbm})(147.9 \text{ Btu}/\text{lbm}) = 1.289 \text{ Btu}/\text{cycle}$$

The power produced is determined from

$$\dot{W}_{\text{net}} = \frac{W_{\text{net}} \dot{n}}{N_{\text{rev}}} = \frac{(1.289 \text{ Btu}/\text{cycle})(2500/60 \text{ rev/s})}{2 \text{ rev}/\text{cycle}} \left(\frac{1 \text{ hp}}{0.7068 \text{ Btu/s}} \right) = \mathbf{38.0 \text{ hp}}$$

since there are two revolutions per cycle in a four-stroke engine.

9-37E An Otto cycle with non-isentropic compression and expansion processes is considered. The thermal efficiency, the heat addition, and the mean effective pressure are to be determined.

Assumptions 1 The air-standard assumptions are applicable. **2** Kinetic and potential energy changes are negligible. **3** Air is an ideal gas with constant specific heats.

Properties The properties of air at room temperature are $R = 0.3704 \text{ psia} \cdot \text{ft}^3/\text{lbm} \cdot \text{R}$ (Table A-1E), $c_p = 0.240 \text{ Btu}/\text{lbm} \cdot \text{R}$, $c_v = 0.171 \text{ Btu}/\text{lbm} \cdot \text{R}$, and $k = 1.4$ (Table A-2Ea).

Analysis We begin by determining the temperatures of the cycle states using the process equations and component efficiencies. The ideal temperature at the end of the compression is then

$$T_{2s} = T_1 \left(\frac{v_1}{v_2} \right)^{k-1} = T_1 r^{k-1} = (520 \text{ R})(8)^{1.4-1} = 1195 \text{ R}$$

With the isentropic compression efficiency, the actual temperature at the end of the compression is

$$\eta = \frac{T_{2s} - T_1}{T_2 - T_1} \longrightarrow T_2 = T_1 + \frac{T_{2s} - T_1}{\eta} = (520 \text{ R}) + \frac{(1195 - 520) \text{ R}}{0.85} = 1314 \text{ R}$$

Similarly for the expansion,

$$T_{4s} = T_3 \left(\frac{v_3}{v_4} \right)^{k-1} = T_3 \left(\frac{1}{r} \right)^{k-1} = (2300 + 460 \text{ R}) \left(\frac{1}{8} \right)^{1.4-1} = 1201 \text{ R}$$

$$\eta = \frac{T_3 - T_4}{T_3 - T_{4s}} \longrightarrow T_4 = T_3 - \eta(T_3 - T_{4s}) = (2760 \text{ R}) - (0.95)(2760 - 1201) \text{ R} = 1279 \text{ R}$$

The specific heat addition is that of process 2-3,

$$q_{\text{in}} = c_v(T_3 - T_2) = (0.171 \text{ Btu}/\text{lbm} \cdot \text{R})(2760 - 1314) \text{ R} = \mathbf{247.3 \text{ Btu}/\text{lbm}}$$

The net work production is the difference between the work produced by the expansion and that used by the compression,

$$\begin{aligned} w_{\text{net}} &= c_v(T_3 - T_4) - c_v(T_2 - T_1) \\ &= (0.171 \text{ Btu}/\text{lbm} \cdot \text{R})(2760 - 1279) \text{ R} - (0.171 \text{ Btu}/\text{lbm} \cdot \text{R})(1314 - 520) \text{ R} \\ &= 117.5 \text{ Btu}/\text{lbm} \end{aligned}$$

The thermal efficiency of this cycle is then

$$\eta_{\text{th}} = \frac{w_{\text{net}}}{q_{\text{in}}} = \frac{117.5 \text{ Btu}/\text{lbm}}{247.3 \text{ Btu}/\text{lbm}} = \mathbf{0.475}$$

At the beginning of compression, the maximum specific volume of this cycle is

$$v_1 = \frac{RT_1}{P_1} = \frac{(0.3704 \text{ psia} \cdot \text{ft}^3/\text{lbm} \cdot \text{R})(520 \text{ R})}{13 \text{ psia}} = 14.82 \text{ ft}^3/\text{lbm}$$

while the minimum specific volume of the cycle occurs at the end of the compression

$$v_2 = \frac{v_1}{r} = \frac{14.82 \text{ ft}^3/\text{lbm}}{8} = 1.852 \text{ ft}^3/\text{lbm}$$

The engine's mean effective pressure is then

$$\text{MEP} = \frac{w_{\text{net}}}{v_1 - v_2} = \frac{117.5 \text{ Btu}/\text{lbm}}{(14.82 - 1.852) \text{ ft}^3/\text{lbm}} \left(\frac{5.404 \text{ psia} \cdot \text{ft}^3}{1 \text{ Btu}} \right) = \mathbf{49.0 \text{ psia}}$$

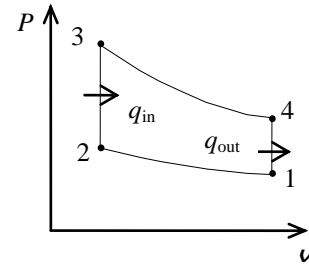

9-38E An ideal Otto cycle with air as the working fluid has a compression ratio of 8. The amount of heat transferred to the air during the heat addition process, the thermal efficiency, and the thermal efficiency of a Carnot cycle operating between the same temperature limits are to be determined.

Assumptions 1 The air-standard assumptions are applicable. **2** Kinetic and potential energy changes are negligible. **3** Air is an ideal gas with variable specific heats.

Properties The properties of air are given in Table A-17E.

Analysis (a) Process 1-2: isentropic compression.

$$T_1 = 540\text{R} \longrightarrow \begin{matrix} u_1 = 92.04\text{Btu/lbm} \\ \nu_{r_1} = 144.32 \end{matrix}$$

$$\nu_{r_2} = \frac{\nu_2}{\nu_1} \nu_{r_2} = \frac{1}{r} \nu_{r_2} = \frac{1}{8}(144.32) = 18.04 \longrightarrow u_2 = 211.28\text{ Btu/lbm}$$

Process 2-3: $\nu = \text{constant}$ heat addition.

$$T_3 = 2400\text{R} \longrightarrow \begin{matrix} u_3 = 452.70\text{ Btu/lbm} \\ \nu_{r_3} = 2.419 \end{matrix}$$

$$q_{in} = u_3 - u_2 = 452.70 - 211.28 = \mathbf{241.42\text{ Btu/lbm}}$$

(b) Process 3-4: isentropic expansion.

$$\nu_{r_4} = \frac{\nu_4}{\nu_3} \nu_{r_3} = r \nu_{r_3} = (8)(2.419) = 19.35 \longrightarrow u_4 = 205.54\text{ Btu/lbm}$$

Process 4-1: $\nu = \text{constant}$ heat rejection.

$$q_{out} = u_4 - u_1 = 205.54 - 92.04 = 113.50\text{ Btu/lbm}$$

$$\eta_{th} = 1 - \frac{q_{out}}{q_{in}} = 1 - \frac{113.50\text{ Btu/lbm}}{241.42\text{ Btu/lbm}} = \mathbf{53.0\%}$$

(c) The thermal efficiency of a Carnot cycle operating between the same temperature limits is

$$\eta_{th,C} = 1 - \frac{T_L}{T_H} = 1 - \frac{540\text{ R}}{2400\text{ R}} = \mathbf{77.5\%}$$

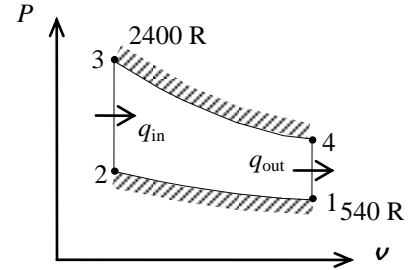

9-39E An ideal Otto cycle with argon as the working fluid has a compression ratio of 8. The amount of heat transferred to the argon during the heat addition process, the thermal efficiency, and the thermal efficiency of a Carnot cycle operating between the same temperature limits are to be determined.

Assumptions 1 The air-standard assumptions are applicable with argon as the working fluid. **2** Kinetic and potential energy changes are negligible. **3** Argon is an ideal gas with constant specific heats.

Properties The properties of argon are $c_p = 0.1253$ Btu/lbm.R, $c_v = 0.0756$ Btu/lbm.R, and $k = 1.667$ (Table A-2E).

Analysis (a) Process 1-2: isentropic compression.

$$T_2 = T_1 \left(\frac{v_1}{v_2} \right)^{k-1} = (540 \text{ R})(8)^{0.667} = 2161 \text{ R}$$

Process 2-3: $v = \text{constant}$ heat addition.

$$\begin{aligned} q_{\text{in}} &= u_3 - u_2 = c_v(T_3 - T_2) \\ &= (0.0756 \text{ Btu/lbm.R})(2400 - 2161) \text{ R} \\ &= \mathbf{18.07 \text{ Btu/lbm}} \end{aligned}$$

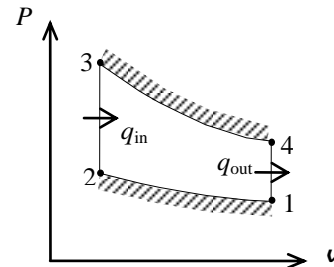

(b) Process 3-4: isentropic expansion.

$$T_4 = T_3 \left(\frac{v_3}{v_4} \right)^{k-1} = (2400 \text{ R}) \left(\frac{1}{8} \right)^{0.667} = 600 \text{ R}$$

Process 4-1: $v = \text{constant}$ heat rejection.

$$q_{\text{out}} = u_4 - u_1 = c_v(T_4 - T_1) = (0.0756 \text{ Btu/lbm.R})(600 - 540) \text{ R} = 4.536 \text{ Btu/lbm}$$

$$\eta_{\text{th}} = 1 - \frac{q_{\text{out}}}{q_{\text{in}}} = 1 - \frac{4.536 \text{ Btu/lbm}}{18.07 \text{ Btu/lbm}} = \mathbf{74.9\%}$$

(c) The thermal efficiency of a Carnot cycle operating between the same temperature limits is

$$\eta_{\text{th,C}} = 1 - \frac{T_L}{T_H} = 1 - \frac{540 \text{ R}}{2400 \text{ R}} = \mathbf{77.5\%}$$

9-40 The expressions for the maximum gas temperature and pressure of an ideal Otto cycle are to be determined when the compression ratio is doubled.

Assumptions 1 The air-standard assumptions are applicable. **2** Kinetic and potential energy changes are negligible. **3** Air is an ideal gas with constant specific heats.

Analysis The temperature at the end of the compression varies with the compression ratio as

$$T_2 = T_1 \left(\frac{v_1}{v_2} \right)^{k-1} = T_1 r^{k-1}$$

since T_1 is fixed. The temperature rise during the combustion remains constant since the amount of heat addition is fixed. Then, the maximum cycle temperature is given by

$$T_3 = q_{in} / c_v + T_2 = q_{in} / c_v + T_1 r^{k-1}$$

The smallest gas specific volume during the cycle is

$$v_3 = \frac{v_1}{r}$$

When this is combined with the maximum temperature, the maximum pressure is given by

$$P_3 = \frac{RT_3}{v_3} = \frac{Rr}{v_1} (q_{in} / c_v + T_1 r^{k-1})$$

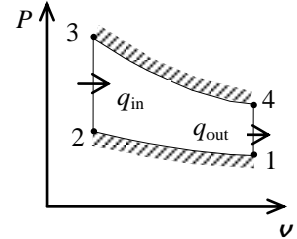

9-41 It is to be determined if the polytropic exponent to be used in an Otto cycle model will be greater than or less than the isentropic exponent.

Assumptions 1 The air-standard assumptions are applicable. **2** Kinetic and potential energy changes are negligible. **3** Air is an ideal gas with constant specific heats.

Analysis During a polytropic process,

$$Pv^n = \text{constant}$$

$$TP^{(n-1)/n} = \text{constant}$$

and for an isentropic process,

$$Pv^k = \text{constant}$$

$$TP^{(k-1)/k} = \text{constant}$$

If heat is lost during the expansion of the gas,

$$T_4 > T_{4s}$$

where T_{4s} is the temperature that would occur if the expansion were reversible and adiabatic ($n=k$). This can only occur when

$$n \leq k$$

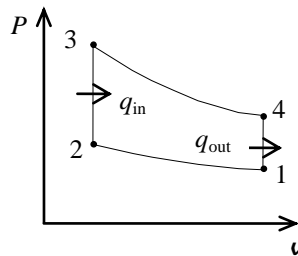

Diesel Cycle

9-42C A diesel engine differs from the gasoline engine in the way combustion is initiated. In diesel engines combustion is initiated by compressing the air above the self-ignition temperature of the fuel whereas it is initiated by a spark plug in a gasoline engine.

9-43C The Diesel cycle differs from the Otto cycle in the heat addition process only; it takes place at constant volume in the Otto cycle, but at constant pressure in the Diesel cycle.

9-44C The gasoline engine.

9-45C Diesel engines operate at high compression ratios because the diesel engines do not have the engine knock problem.

9-46 An air-standard Diesel cycle with a compression ratio of 16 and a cutoff ratio of 2 is considered. The temperature after the heat addition process, the thermal efficiency, and the mean effective pressure are to be determined.

Assumptions 1 The air-standard assumptions are applicable. **2** Kinetic and potential energy changes are negligible. **3** Air is an ideal gas with variable specific heats.

Properties The gas constant of air is $R = 0.287 \text{ kJ/kg}\cdot\text{K}$. The properties of air are given in Table A-17.

Analysis (a) Process 1-2: isentropic compression.

$$T_1 = 300\text{K} \longrightarrow \begin{array}{l} u_1 = 214.07\text{kJ/kg} \\ \nu_{r_1} = 621.2 \end{array}$$

$$\nu_{r_2} = \frac{\nu_2}{\nu_1} \nu_{r_1} = \frac{1}{r} \nu_{r_1} = \frac{1}{16} (621.2) = 38.825 \longrightarrow \begin{array}{l} T_2 = 862.4 \text{ K} \\ h_2 = 890.9 \text{ kJ/kg} \end{array}$$

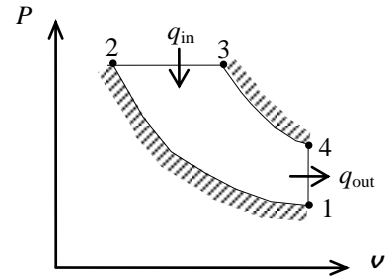

Process 2-3: $P = \text{constant}$ heat addition.

$$\frac{P_3 \nu_3}{T_3} = \frac{P_2 \nu_2}{T_2} \longrightarrow T_3 = \frac{\nu_3}{\nu_2} T_2 = 2T_2 = (2)(862.4 \text{ K}) = \mathbf{1724.8 \text{ K}} \longrightarrow \begin{array}{l} h_3 = 1910.6 \text{ kJ/kg} \\ \nu_{r_3} = 4.546 \end{array}$$

$$(b) \quad q_{\text{in}} = h_3 - h_2 = 1910.6 - 890.9 = 1019.7 \text{ kJ/kg}$$

Process 3-4: isentropic expansion.

$$\nu_{r_4} = \frac{\nu_4}{\nu_3} \nu_{r_3} = \frac{\nu_4}{2\nu_2} \nu_{r_3} = \frac{r}{2} \nu_{r_3} = \frac{16}{2} (4.546) = 36.37 \longrightarrow u_4 = 659.7 \text{ kJ/kg}$$

Process 4-1: $\nu = \text{constant}$ heat rejection.

$$q_{\text{out}} = u_4 - u_1 = 659.7 - 214.07 = 445.63 \text{ kJ/kg}$$

$$\eta_{\text{th}} = 1 - \frac{q_{\text{out}}}{q_{\text{in}}} = 1 - \frac{445.63 \text{ kJ/kg}}{1019.7 \text{ kJ/kg}} = \mathbf{56.3\%}$$

$$(c) \quad w_{\text{net,out}} = q_{\text{in}} - q_{\text{out}} = 1019.7 - 445.63 = 574.07 \text{ kJ/kg}$$

$$\nu_1 = \frac{RT_1}{P_1} = \frac{(0.287 \text{ kPa}\cdot\text{m}^3/\text{kg}\cdot\text{K})(300 \text{ K})}{95 \text{ kPa}} = 0.906 \text{ m}^3/\text{kg} = \nu_{\text{max}}$$

$$\nu_{\text{min}} = \nu_2 = \frac{\nu_{\text{max}}}{r}$$

$$\text{MEP} = \frac{w_{\text{net,out}}}{\nu_1 - \nu_2} = \frac{w_{\text{net,out}}}{\nu_1(1 - 1/r)} = \frac{574.07 \text{ kJ/kg}}{(0.906 \text{ m}^3/\text{kg})(1 - 1/16)} \left(\frac{\text{kPa}\cdot\text{m}^3}{\text{kJ}} \right) = \mathbf{675.9 \text{ kPa}}$$

9-47 An air-standard Diesel cycle with a compression ratio of 16 and a cutoff ratio of 2 is considered. The temperature after the heat addition process, the thermal efficiency, and the mean effective pressure are to be determined.

Assumptions 1 The air-standard assumptions are applicable. **2** Kinetic and potential energy changes are negligible. **3** Air is an ideal gas with constant specific heats.

Properties The properties of air at room temperature are $c_p = 1.005 \text{ kJ/kg}\cdot\text{K}$, $c_v = 0.718 \text{ kJ/kg}\cdot\text{K}$, $R = 0.287 \text{ kJ/kg}\cdot\text{K}$, and $k = 1.4$ (Table A-2).

Analysis (a) Process 1-2: isentropic compression.

$$T_2 = T_1 \left(\frac{v_1}{v_2} \right)^{k-1} = (300\text{K})(16)^{0.4} = 909.4\text{K}$$

Process 2-3: $P = \text{constant}$ heat addition.

$$\frac{P_3 v_3}{T_3} = \frac{P_2 v_2}{T_2} \longrightarrow T_3 = \frac{v_3}{v_2} T_2 = 2T_2 = (2)(909.4\text{K}) = \mathbf{1818.8\text{K}}$$

$$(b) \quad q_{\text{in}} = h_3 - h_2 = c_p(T_3 - T_2) = (1.005 \text{ kJ/kg}\cdot\text{K})(1818.8 - 909.4)\text{K} = 913.9 \text{ kJ/kg}$$

Process 3-4: isentropic expansion.

$$T_4 = T_3 \left(\frac{v_3}{v_4} \right)^{k-1} = T_3 \left(\frac{2v_2}{v_4} \right)^{k-1} = (1818.8\text{K}) \left(\frac{2}{16} \right)^{0.4} = 791.7\text{K}$$

Process 4-1: $v = \text{constant}$ heat rejection.

$$q_{\text{out}} = u_4 - u_1 = c_v(T_4 - T_1) = (0.718 \text{ kJ/kg}\cdot\text{K})(791.7 - 300)\text{K} = 353 \text{ kJ/kg}$$

$$\eta_{\text{th}} = 1 - \frac{q_{\text{out}}}{q_{\text{in}}} = 1 - \frac{353 \text{ kJ/kg}}{913.9 \text{ kJ/kg}} = \mathbf{61.4\%}$$

$$(c) \quad w_{\text{net,out}} = q_{\text{in}} - q_{\text{out}} = 913.9 - 353 = 560.9 \text{ kJ/kg}$$

$$v_1 = \frac{RT_1}{P_1} = \frac{(0.287 \text{ kPa}\cdot\text{m}^3/\text{kg}\cdot\text{K})(300 \text{ K})}{95 \text{ kPa}} = 0.906 \text{ m}^3/\text{kg} = v_{\text{max}}$$

$$v_{\text{min}} = v_2 = \frac{v_{\text{max}}}{r}$$

$$\text{MEP} = \frac{w_{\text{net,out}}}{v_1 - v_2} = \frac{w_{\text{net,out}}}{v_1(1 - 1/r)} = \frac{560.9 \text{ kJ/kg}}{(0.906 \text{ m}^3/\text{kg})(1 - 1/16)} \left(\frac{\text{kPa}\cdot\text{m}^3}{\text{kJ}} \right) = \mathbf{660.4 \text{ kPa}}$$

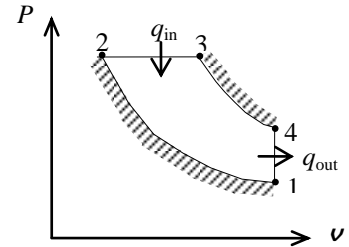

9-48 An ideal diesel cycle has a compression ratio of 17 and a cutoff ratio of 1.3. The maximum temperature of the air and the rate of heat addition are to be determined.

Assumptions 1 The air-standard assumptions are applicable. 2 Kinetic and potential energy changes are negligible. 3 Air is an ideal gas with constant specific heats.

Properties The properties of air at room temperature are $c_p = 1.005 \text{ kJ/kg}\cdot\text{K}$, $c_v = 0.718 \text{ kJ/kg}\cdot\text{K}$, $R = 0.287 \text{ kJ/kg}\cdot\text{K}$, and $k = 1.4$ (Table A-2a).

Analysis We begin by using the process types to fix the temperatures of the states.

$$T_2 = T_1 \left(\frac{v_1}{v_2} \right)^{k-1} = T_1 r^{k-1} = (330 \text{ K})(17)^{1.4-1} = 1025 \text{ K}$$

$$T_3 = T_2 \left(\frac{v_3}{v_2} \right) = T_2 r_c = (1025 \text{ K})(1.3) = \mathbf{1332 \text{ K}}$$

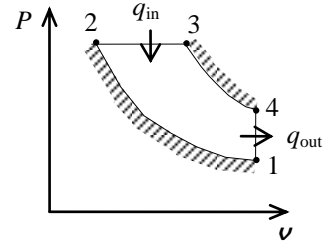

Combining the first law as applied to the various processes with the process equations gives

$$\eta_{\text{th}} = 1 - \frac{1}{r^{k-1}} \frac{r_c^k - 1}{k(r_c - 1)} = 1 - \frac{1}{17^{1.4-1}} \frac{1.3^{1.4} - 1}{1.4(1.3 - 1)} = 0.6597$$

According to the definition of the thermal efficiency,

$$\dot{Q}_{\text{in}} = \frac{\dot{W}_{\text{net}}}{\eta_{\text{th}}} = \frac{140 \text{ kW}}{0.6597} = \mathbf{212 \text{ kW}}$$

9-49E An ideal diesel cycle has a cutoff ratio of 1.4. The power produced is to be determined.

Assumptions 1 The air-standard assumptions are applicable. **2** Kinetic and potential energy changes are negligible. **3** Air is an ideal gas with constant specific heats.

Properties The properties of air at room temperature are $R = 0.3704 \text{ psia} \cdot \text{ft}^3/\text{lbm} \cdot \text{R}$ (Table A-1E), $c_p = 0.240 \text{ Btu}/\text{lbm} \cdot \text{R}$, $c_v = 0.171 \text{ Btu}/\text{lbm} \cdot \text{R}$, and $k = 1.4$ (Table A-2Ea).

Analysis The specific volume of the air at the start of the compression is

$$\nu_1 = \frac{RT_1}{P_1} = \frac{(0.3704 \text{ psia} \cdot \text{ft}^3/\text{lbm} \cdot \text{R})(510 \text{ R})}{14.4 \text{ psia}} = 13.12 \text{ ft}^3/\text{lbm}$$

The total air mass taken by all 8 cylinders when they are charged is

$$m = N_{\text{cyl}} \frac{\Delta V}{\nu_1} = N_{\text{cyl}} \frac{\pi B^2 S / 4}{\nu_1} = (8) \frac{\pi (4/12 \text{ ft})^2 (4/12 \text{ ft}) / 4}{13.12 \text{ ft}^3/\text{lbm}} = 0.01774 \text{ lbm}$$

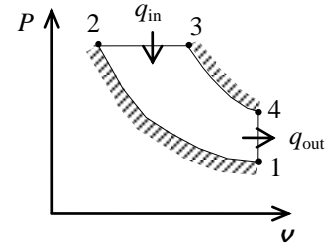

The rate at which air is processed by the engine is determined from

$$\dot{m} = \frac{m\dot{n}}{N_{\text{rev}}} = \frac{(0.01774 \text{ lbm}/\text{cycle})(1800/60 \text{ rev/s})}{2 \text{ rev}/\text{cycle}} = 0.2661 \text{ lbm/s} = 958.0 \text{ lbm/h}$$

since there are two revolutions per cycle in a four-stroke engine. The compression ratio is

$$r = \frac{1}{0.045} = 22.22$$

At the end of the compression, the air temperature is

$$T_2 = T_1 r^{k-1} = (510 \text{ R})(22.22)^{1.4-1} = 1763 \text{ R}$$

Application of the first law and work integral to the constant pressure heat addition gives

$$q_{\text{in}} = c_p (T_3 - T_2) = (0.240 \text{ Btu}/\text{lbm} \cdot \text{R})(2760 - 1763) \text{ R} = 239.3 \text{ Btu}/\text{lbm}$$

while the thermal efficiency is

$$\eta_{\text{th}} = 1 - \frac{1}{r^{k-1}} \frac{r_c^k - 1}{k(r_c - 1)} = 1 - \frac{1}{22.22^{1.4-1}} \frac{1.4^{1.4} - 1}{1.4(1.4 - 1)} = 0.6892$$

The power produced by this engine is then

$$\begin{aligned} \dot{W}_{\text{net}} &= \dot{m} w_{\text{net}} = \dot{m} \eta_{\text{th}} q_{\text{in}} \\ &= (958.0 \text{ lbm/h})(0.6892)(239.3 \text{ Btu}/\text{lbm}) \left(\frac{1 \text{ hp}}{2544.5 \text{ Btu/h}} \right) \\ &= \mathbf{62.1 \text{ hp}} \end{aligned}$$

9-50 An ideal dual cycle has a compression ratio of 14 and cutoff ratio of 1.2. The thermal efficiency, amount of heat added, and the maximum gas pressure and temperature are to be determined.

Assumptions 1 The air-standard assumptions are applicable. **2** Kinetic and potential energy changes are negligible. **3** Air is an ideal gas with constant specific heats.

Properties The properties of air at room temperature are $c_p = 1.005 \text{ kJ/kg}\cdot\text{K}$, $c_v = 0.718 \text{ kJ/kg}\cdot\text{K}$, $R = 0.287 \text{ kJ/kg}\cdot\text{K}$, and $k = 1.4$ (Table A-2a).

Analysis The specific volume of the air at the start of the compression is

$$\nu_1 = \frac{RT_1}{P_1} = \frac{(0.287 \text{ kPa}\cdot\text{m}^3/\text{kg}\cdot\text{K})(293 \text{ K})}{80 \text{ kPa}} = 1.051 \text{ m}^3/\text{kg}$$

and the specific volume at the end of the compression is

$$\nu_2 = \frac{\nu_1}{r} = \frac{1.051 \text{ m}^3/\text{kg}}{14} = 0.07508 \text{ m}^3/\text{kg}$$

The pressure at the end of the compression is

$$P_2 = P_1 \left(\frac{\nu_1}{\nu_2} \right)^k = P_1 r^k = (80 \text{ kPa})(14)^{1.4} = 3219 \text{ kPa}$$

and the maximum pressure is

$$P_x = P_3 = r_p P_2 = (1.5)(3219 \text{ kPa}) = \mathbf{4829 \text{ kPa}}$$

The temperature at the end of the compression is

$$T_2 = T_1 \left(\frac{\nu_1}{\nu_2} \right)^{k-1} = T_1 r^{k-1} = (293 \text{ K})(14)^{1.4-1} = 842.0 \text{ K}$$

and
$$T_x = T_2 \left(\frac{P_3}{P_2} \right) = (842.0 \text{ K}) \left(\frac{4829 \text{ kPa}}{3219 \text{ kPa}} \right) = 1263 \text{ K}$$

From the definition of cutoff ratio

$$\nu_3 = r_c \nu_x = r_c \nu_2 = (1.2)(0.07508 \text{ m}^3/\text{kg}) = 0.09010 \text{ m}^3/\text{kg}$$

The remaining state temperatures are then

$$T_3 = T_x \left(\frac{\nu_3}{\nu_x} \right) = (1263 \text{ K}) \left(\frac{0.09010}{0.07508} \right) = \mathbf{1516 \text{ K}}$$

$$T_4 = T_3 \left(\frac{\nu_3}{\nu_4} \right)^{k-1} = (1516 \text{ K}) \left(\frac{0.09010}{1.051} \right)^{1.4-1} = 567.5 \text{ K}$$

Applying the first law and work expression to the heat addition processes gives

$$\begin{aligned} q_{\text{in}} &= c_v(T_x - T_2) + c_p(T_3 - T_x) \\ &= (0.718 \text{ kJ/kg}\cdot\text{K})(1263 - 842.0)\text{K} + (1.005 \text{ kJ/kg}\cdot\text{K})(1516 - 1263)\text{K} \\ &= \mathbf{556.5 \text{ kJ/kg}} \end{aligned}$$

The heat rejected is

$$q_{\text{out}} = c_v(T_4 - T_1) = (0.718 \text{ kJ/kg}\cdot\text{K})(567.5 - 293)\text{K} = 197.1 \text{ kJ/kg}$$

Then,
$$\eta_{\text{th}} = 1 - \frac{q_{\text{out}}}{q_{\text{in}}} = 1 - \frac{197.1 \text{ kJ/kg}}{556.5 \text{ kJ/kg}} = \mathbf{0.646}$$

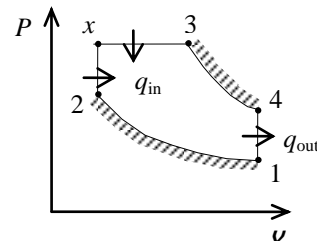

9-51 An ideal dual cycle has a compression ratio of 14 and cutoff ratio of 1.2. The thermal efficiency, amount of heat added, and the maximum gas pressure and temperature are to be determined.

Assumptions 1 The air-standard assumptions are applicable. **2** Kinetic and potential energy changes are negligible. **3** Air is an ideal gas with constant specific heats.

Properties The properties of air at room temperature are $c_p = 1.005 \text{ kJ/kg}\cdot\text{K}$, $c_v = 0.718 \text{ kJ/kg}\cdot\text{K}$, $R = 0.287 \text{ kJ/kg}\cdot\text{K}$, and $k = 1.4$ (Table A-2).

Analysis The specific volume of the air at the start of the compression is

$$\nu_1 = \frac{RT_1}{P_1} = \frac{(0.287 \text{ kPa}\cdot\text{m}^3/\text{kg}\cdot\text{K})(253 \text{ K})}{80 \text{ kPa}} = 0.9076 \text{ m}^3/\text{kg}$$

and the specific volume at the end of the compression is

$$\nu_2 = \frac{\nu_1}{r} = \frac{0.9076 \text{ m}^3/\text{kg}}{14} = 0.06483 \text{ m}^3/\text{kg}$$

The pressure at the end of the compression is

$$P_2 = P_1 \left(\frac{\nu_1}{\nu_2} \right)^k = P_1 r^k = (80 \text{ kPa})(14)^{1.4} = 3219 \text{ kPa}$$

and the maximum pressure is

$$P_x = P_3 = r_p P_2 = (1.5)(3219 \text{ kPa}) = \mathbf{4829 \text{ kPa}}$$

The temperature at the end of the compression is

$$T_2 = T_1 \left(\frac{\nu_1}{\nu_2} \right)^{k-1} = T_1 r^{k-1} = (253 \text{ K})(14)^{1.4-1} = 727.1 \text{ K}$$

and

$$T_x = T_2 \left(\frac{P_3}{P_2} \right) = (727.1 \text{ K}) \left(\frac{4829 \text{ kPa}}{3219 \text{ kPa}} \right) = 1091 \text{ K}$$

From the definition of cutoff ratio

$$\nu_3 = r_c \nu_x = r_c \nu_2 = (1.2)(0.06483 \text{ m}^3/\text{kg}) = 0.07780 \text{ m}^3/\text{kg}$$

The remaining state temperatures are then

$$T_3 = T_x \left(\frac{\nu_3}{\nu_x} \right) = (1091 \text{ K}) \left(\frac{0.07780}{0.06483} \right) = \mathbf{1309 \text{ K}}$$

$$T_4 = T_3 \left(\frac{\nu_3}{\nu_4} \right)^{k-1} = (1309 \text{ K}) \left(\frac{0.07780}{0.9076} \right)^{1.4-1} = 490.0 \text{ K}$$

Applying the first law and work expression to the heat addition processes gives

$$\begin{aligned} q_{\text{in}} &= c_v(T_x - T_2) + c_p(T_3 - T_x) \\ &= (0.718 \text{ kJ/kg}\cdot\text{K})(1091 - 727.1)\text{K} + (1.005 \text{ kJ/kg}\cdot\text{K})(1309 - 1091)\text{K} \\ &= \mathbf{480.4 \text{ kJ/kg}} \end{aligned}$$

The heat rejected is

$$q_{\text{out}} = c_v(T_4 - T_1) = (0.718 \text{ kJ/kg}\cdot\text{K})(490.0 - 253)\text{K} = 170.2 \text{ kJ/kg}$$

Then,

$$\eta_{\text{th}} = 1 - \frac{q_{\text{out}}}{q_{\text{in}}} = 1 - \frac{170.2 \text{ kJ/kg}}{480.4 \text{ kJ/kg}} = \mathbf{0.646}$$

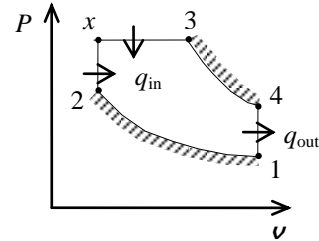

9-52E An air-standard Diesel cycle with a compression ratio of 18.2 is considered. The cutoff ratio, the heat rejection per unit mass, and the thermal efficiency are to be determined.

Assumptions 1 The air-standard assumptions are applicable. **2** Kinetic and potential energy changes are negligible. **3** Air is an ideal gas with variable specific heats.

Properties The properties of air are given in Table A-17E.

Analysis (a) Process 1-2: isentropic compression.

$$T_1 = 580 \text{ R} \longrightarrow \begin{array}{l} u_1 = 98.90 \text{ Btu/lbm} \\ v_{r_1} = 120.70 \end{array}$$

$$v_{r_2} = \frac{v_2}{v_1} v_{r_1} = \frac{1}{r} v_{r_1} = \frac{1}{18.2} (120.70) = 6.632 \longrightarrow \begin{array}{l} T_2 = 1725.8 \text{ R} \\ h_2 = 429.56 \text{ Btu/lbm} \end{array}$$

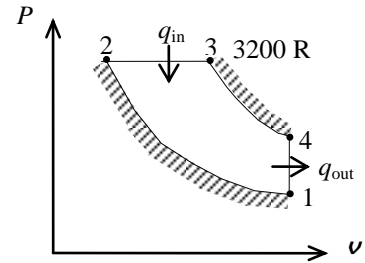

Process 2-3: $P = \text{constant}$ heat addition.

$$\frac{P_3 v_3}{T_3} = \frac{P_2 v_2}{T_2} \longrightarrow \frac{v_3}{v_2} = \frac{T_3}{T_2} = \frac{3200 \text{ R}}{1725.8 \text{ R}} = \mathbf{1.854}$$

$$(b) \quad T_3 = 3200 \text{ R} \longrightarrow \begin{array}{l} h_3 = 849.48 \text{ Btu/lbm} \\ v_{r_3} = 0.955 \end{array}$$

$$q_{\text{in}} = h_3 - h_2 = 849.48 - 429.56 = 419.9 \text{ Btu/lbm}$$

Process 3-4: isentropic expansion.

$$v_{r_4} = \frac{v_4}{v_3} v_{r_3} = \frac{v_4}{1.854 v_2} v_{r_3} = \frac{r}{1.854} v_{r_3} = \frac{18.2}{1.854} (0.955) = 9.375 \longrightarrow u_4 = 272.58 \text{ Btu/lbm}$$

Process 4-1: $v = \text{constant}$ heat rejection:

$$q_{\text{out}} = u_4 - u_1 = 272.58 - 98.90 = \mathbf{173.7 \text{ Btu/lbm}}$$

$$(c) \quad \eta_{\text{th}} = 1 - \frac{q_{\text{out}}}{q_{\text{in}}} = 1 - \frac{173.7 \text{ Btu/lbm}}{419.9 \text{ Btu/lbm}} = 0.586 = \mathbf{58.6\%}$$

9-53E An air-standard Diesel cycle with a compression ratio of 18.2 is considered. The cutoff ratio, the heat rejection per unit mass, and the thermal efficiency are to be determined.

Assumptions 1 The air-standard assumptions are applicable. **2** Kinetic and potential energy changes are negligible. **3** Air is an ideal gas with constant specific heats.

Properties The properties of air at room temperature are $c_p = 0.240$ Btu/lbm.R, $c_v = 0.171$ Btu/lbm.R, and $k = 1.4$ (Table A-2E).

Analysis (a) Process 1-2: isentropic compression.

$$T_2 = T_1 \left(\frac{v_1}{v_2} \right)^{k-1} = (580 \text{ R})(18.2)^{0.4} = 1851 \text{ R}$$

Process 2-3: $P = \text{constant}$ heat addition.

$$\frac{P_3 v_3}{T_3} = \frac{P_2 v_2}{T_2} \longrightarrow \frac{v_3}{v_2} = \frac{T_3}{T_2} = \frac{3200 \text{ R}}{1851 \text{ R}} = \mathbf{1.729}$$

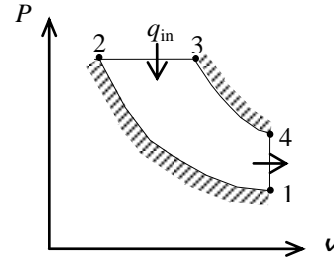

$$(b) \quad q_{\text{in}} = h_3 - h_2 = c_p(T_3 - T_2) = (0.240 \text{ Btu/lbm.R})(3200 - 1851) \text{ R} = 323.7 \text{ Btu/lbm}$$

Process 3-4: isentropic expansion.

$$T_4 = T_3 \left(\frac{v_3}{v_4} \right)^{k-1} = T_3 \left(\frac{1.729 v_2}{v_4} \right)^{k-1} = (3200 \text{ R}) \left(\frac{1.729}{18.2} \right)^{0.4} = 1248 \text{ R}$$

Process 4-1: $v = \text{constant}$ heat rejection.

$$\begin{aligned} q_{\text{out}} &= u_4 - u_1 = c_v(T_4 - T_1) \\ &= (0.171 \text{ Btu/lbm.R})(1248 - 580) \text{ R} \\ &= \mathbf{114.2 \text{ Btu/lbm}} \end{aligned}$$

$$(c) \quad \eta_{\text{th}} = 1 - \frac{q_{\text{out}}}{q_{\text{in}}} = 1 - \frac{114.2 \text{ Btu/lbm}}{323.7 \text{ Btu/lbm}} = 0.6472 = \mathbf{64.7\%}$$

9-54 An ideal diesel engine with air as the working fluid has a compression ratio of 20. The thermal efficiency and the mean effective pressure are to be determined.

Assumptions 1 The air-standard assumptions are applicable. **2** Kinetic and potential energy changes are negligible. **3** Air is an ideal gas with constant specific heats.

Properties The properties of air at room temperature are $c_p = 1.005 \text{ kJ/kg}\cdot\text{K}$, $c_v = 0.718 \text{ kJ/kg}\cdot\text{K}$, $R = 0.287 \text{ kJ/kg}\cdot\text{K}$, and $k = 1.4$ (Table A-2).

Analysis (a) Process 1-2: isentropic compression.

$$T_2 = T_1 \left(\frac{v_1}{v_2} \right)^{k-1} = (293 \text{ K})(20)^{0.4} = 971.1 \text{ K}$$

Process 2-3: $P = \text{constant}$ heat addition.

$$\frac{P_3 v_3}{T_3} = \frac{P_2 v_2}{T_2} \longrightarrow \frac{v_3}{v_2} = \frac{T_3}{T_2} = \frac{2200 \text{ K}}{971.1 \text{ K}} = 2.265$$

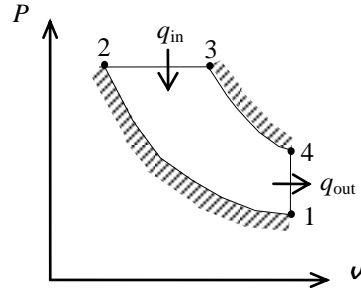

Process 3-4: isentropic expansion.

$$T_4 = T_3 \left(\frac{v_3}{v_4} \right)^{k-1} = T_3 \left(\frac{2.265 v_2}{v_4} \right)^{k-1} = T_3 \left(\frac{2.265}{r} \right)^{k-1} = (2200 \text{ K}) \left(\frac{2.265}{20} \right)^{0.4} = 920.6 \text{ K}$$

$$q_{\text{in}} = h_3 - h_2 = c_p (T_3 - T_2) = (1.005 \text{ kJ/kg}\cdot\text{K})(2200 - 971.1) \text{ K} = 1235 \text{ kJ/kg}$$

$$q_{\text{out}} = u_4 - u_1 = c_v (T_4 - T_1) = (0.718 \text{ kJ/kg}\cdot\text{K})(920.6 - 293) \text{ K} = 450.6 \text{ kJ/kg}$$

$$w_{\text{net,out}} = q_{\text{in}} - q_{\text{out}} = 1235 - 450.6 = 784.4 \text{ kJ/kg}$$

$$\eta_{\text{th}} = \frac{w_{\text{net,out}}}{q_{\text{in}}} = \frac{784.4 \text{ kJ/kg}}{1235 \text{ kJ/kg}} = \mathbf{63.5\%}$$

$$(b) \quad v_1 = \frac{RT_1}{P_1} = \frac{(0.287 \text{ kPa}\cdot\text{m}^3/\text{kg}\cdot\text{K})(293 \text{ K})}{95 \text{ kPa}} = 0.885 \text{ m}^3/\text{kg} = v_{\text{max}}$$

$$v_{\text{min}} = v_2 = \frac{v_{\text{max}}}{r}$$

$$\text{MEP} = \frac{w_{\text{net,out}}}{v_1 - v_2} = \frac{w_{\text{net,out}}}{v_1 (1 - 1/r)} = \frac{784.4 \text{ kJ/kg}}{(0.885 \text{ m}^3/\text{kg})(1 - 1/20)} \left(\frac{\text{kPa}\cdot\text{m}^3}{\text{kJ}} \right) = \mathbf{933 \text{ kPa}}$$

9-55 A diesel engine with air as the working fluid has a compression ratio of 20. The thermal efficiency and the mean effective pressure are to be determined.

Assumptions 1 The air-standard assumptions are applicable. **2** Kinetic and potential energy changes are negligible. **3** Air is an ideal gas with constant specific heats.

Properties The gas constant of air is $R = 0.287 \text{ kJ/kg}\cdot\text{K}$ (Table A-2).

Analysis (a) Process 1-2: isentropic compression.

$$T_1 = 293 \text{ K} \longrightarrow \begin{matrix} u_1 = 209.06 \text{ kJ/kg} \\ \nu_{r_1} = 659.2 \end{matrix} \quad (\text{Table A-17})$$

$$\nu_{r_2} = \frac{\nu_2}{\nu_1} \nu_{r_1} = \frac{1}{r} \nu_{r_1} = \frac{1}{20} (659.2) = 32.96 \longrightarrow \begin{matrix} T_2 = 912.7 \text{ K} \\ h_2 = 947.17 \text{ kJ/kg} \end{matrix} \quad (\text{Table A-17})$$

Process 2-3: $P = \text{constant}$ heat addition.

$$\frac{P_3 \nu_3}{T_3} = \frac{P_2 \nu_2}{T_2} \longrightarrow \frac{\nu_3}{\nu_2} = \frac{T_3}{T_2} = \frac{2200 \text{ K}}{912.7 \text{ K}} = 2.410$$

$$T_3 = 2200 \text{ K} \longrightarrow \begin{matrix} h_3 = 2503.2 \text{ kJ/kg}, \\ u_3 = 1872.4 \text{ kJ/kg} \end{matrix} \quad (\text{Table A-17})$$

$$q_{\text{in}} = h_3 - h_2 = 2503.2 - 947.17 = 1556.0 \text{ kJ/kg}$$

Process 3-4: polytropic expansion.

$$T_4 = T_3 \left(\frac{\nu_3}{\nu_4} \right)^{n-1} = T_3 \left(\frac{2.410 \nu_2}{\nu_4} \right)^{n-1} = T_3 \left(\frac{2.410}{r} \right)^{n-1} = (2200 \text{ K}) \left(\frac{2.410}{20} \right)^{0.35} = 1049 \text{ K}$$

$$w_{34,\text{out}} = \frac{R(T_4 - T_3)}{1 - n} = \frac{(0.287 \text{ kJ/kg}\cdot\text{K})(1049 - 2200) \text{ K}}{1 - 1.35} = 943.8 \text{ kJ/kg}$$

$$T_4 = 1049 \text{ K} \longrightarrow u_4 = 801.13 \text{ kJ/kg} \quad (\text{Table A-17})$$

An energy balance gives

$$E_{\text{in}} - E_{\text{out}} = \Delta E_{\text{system}}$$

$$\begin{aligned} -q_{34,\text{out}} - w_{34,\text{out}} &= u_4 - u_3 \longrightarrow q_{34,\text{out}} = -w_{34,\text{out}} - (u_4 - u_3) \\ &= -943.8 \text{ kJ/kg} - (801.13 - 1872.4) \text{ kJ/kg} = 127.5 \text{ kJ/kg} \end{aligned}$$

Process 4-1: $\nu = \text{constant}$ heat rejection.

$$q_{41,\text{out}} = u_4 - u_1 = (801.13 - 209.06) \text{ kJ/kg} = 592.1 \text{ kJ/kg}$$

Total heat rejected is

$$q_{\text{out}} = q_{34,\text{out}} + q_{41,\text{out}} = 127.5 + 592.1 = 719.6 \text{ kJ/kg}$$

and

$$w_{\text{net,out}} = q_{\text{in}} - q_{\text{out}} = 1556 - 719.6 = 836.4 \text{ kJ/kg}$$

$$\eta_{\text{th}} = \frac{w_{\text{net,out}}}{q_{\text{in}}} = \frac{836.4 \text{ kJ/kg}}{1556 \text{ kJ/kg}} = 0.5375 = \mathbf{53.8\%}$$

$$(b) \quad \nu_1 = \frac{RT_1}{P_1} = \frac{(0.287 \text{ kPa}\cdot\text{m}^3/\text{kg}\cdot\text{K})(293 \text{ K})}{95 \text{ kPa}} = 0.8852 \text{ m}^3/\text{kg} = \nu_{\text{max}}$$

$$\nu_{\text{min}} = \nu_2 = \frac{\nu_{\text{max}}}{r}$$

$$\text{MEP} = \frac{w_{\text{net,out}}}{\nu_1 - \nu_2} = \frac{w_{\text{net,out}}}{\nu_1(1 - 1/r)} = \frac{836.4 \text{ kJ/kg}}{(0.8852 \text{ m}^3/\text{kg})(1 - 1/20)} \left(\frac{1 \text{ kPa}\cdot\text{m}^3}{\text{kJ}} \right) = \mathbf{995 \text{ kPa}}$$

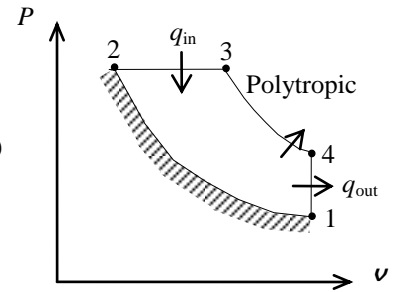



9-56 Problem 9-55 is reconsidered. The effect of the compression ratio on the net work output, mean effective pressure, and thermal efficiency is to be investigated. Also, T - s and P - v diagrams for the cycle are to be plotted.

Analysis Using EES, the problem is solved as follows:

```

Procedure QTotal(q_12,q_23,q_34,q_41: q_in_total,q_out_total)
q_in_total = 0
q_out_total = 0
IF (q_12 > 0) THEN q_in_total = q_12 ELSE q_out_total = - q_12
If q_23 > 0 then q_in_total = q_in_total + q_23 else q_out_total = q_out_total - q_23
If q_34 > 0 then q_in_total = q_in_total + q_34 else q_out_total = q_out_total - q_34
If q_41 > 0 then q_in_total = q_in_total + q_41 else q_out_total = q_out_total - q_41
END

```

"Input Data"

```

T[1]=293 [K]
P[1]=95 [kPa]
T[3] = 2200 [K]
n=1.35
{r_comp = 20}

```

"Process 1-2 is isentropic compression"

```

s[1]=entropy(air,T=T[1],P=P[1])
s[2]=s[1]
T[2]=temperature(air, s=s[2], P=P[2])
P[2]*v[2]/T[2]=P[1]*v[1]/T[1]
P[1]*v[1]=R*T[1]
R=0.287 [kJ/kg-K]
V[2] = V[1]/ r_comp

```

"Conservation of energy for process 1 to 2"

```

q_12 - w_12 = DELTAu_12
q_12 =0"isentropic process"
DELTAu_12=intenergy(air,T=T[2])-intenergy(air,T=T[1])

```

"Process 2-3 is constant pressure heat addition"

```

P[3]=P[2]
s[3]=entropy(air, T=T[3], P=P[3])
P[3]*v[3]=R*T[3]

```

"Conservation of energy for process 2 to 3"

```

q_23 - w_23 = DELTAu_23
w_23 =P[2]*(V[3] - V[2])"constant pressure process"
DELTAu_23=intenergy(air,T=T[3])-intenergy(air,T=T[2])

```

"Process 3-4 is polytropic expansion"

```

P[3]/P[4] =(V[4]/V[3])^n
s[4]=entropy(air,T=T[4],P=P[4])
P[4]*v[4]=R*T[4]

```

"Conservation of energy for process 3 to 4"

```

q_34 - w_34 = DELTAu_34 "q_34 is not 0 for the ploytropic process"
DELTAu_34=intenergy(air,T=T[4])-intenergy(air,T=T[3])
P[3]*V[3]^n = Const

```

```

w_34=(P[4]*V[4]-P[3]*V[3])/(1-n)

```

"Process 4-1 is constant volume heat rejection"

```

V[4] = V[1]
"Conservation of energy for process 4 to 1"
q_41 - w_41 = DELTAu_41
w_41 =0 "constant volume process"
DELTAu_41=intenergy(air,T=T[1])-intenergy(air,T=T[4])

```

```

Call QTotal(q_12,q_23,q_34,q_41: q_in_total,q_out_total)

```

```

w_net = w_12+w_23+w_34+w_41

```

$\eta_{th} = w_{net}/q_{in_total} * 100$ "Thermal efficiency, in percent"

"The mean effective pressure is:"

$MEP = w_{net}/(V[1]-V[2])$

r_{comp}	η_{th}	MEP [kPa]	w_{net} [kJ/kg]
14	47.69	970.8	797.9
16	50.14	985	817.4
18	52.16	992.6	829.8
20	53.85	995.4	837.0
22	55.29	994.9	840.6
24	56.54	992	841.5

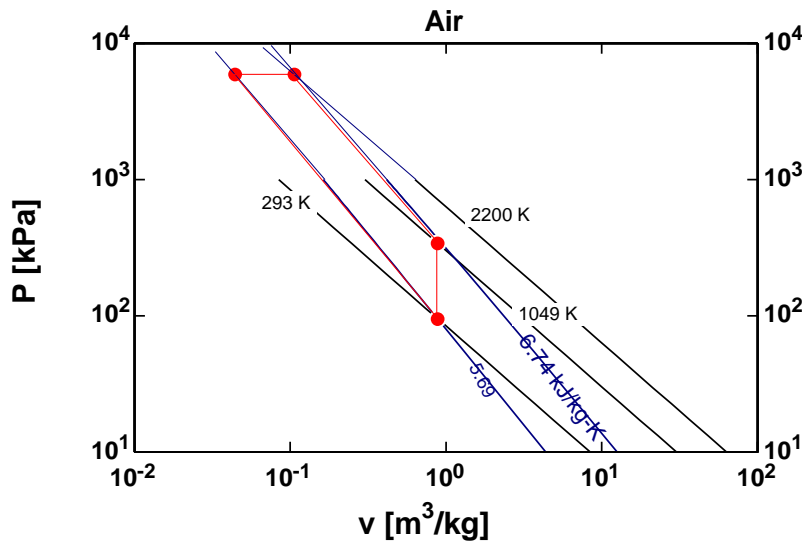
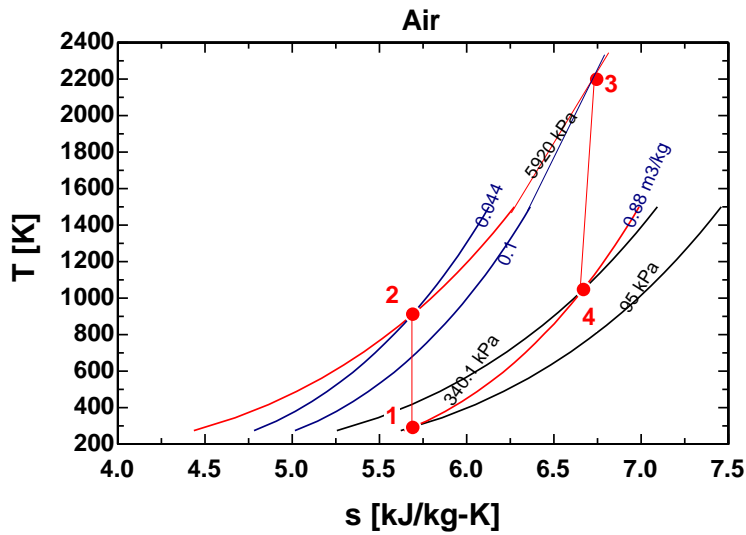

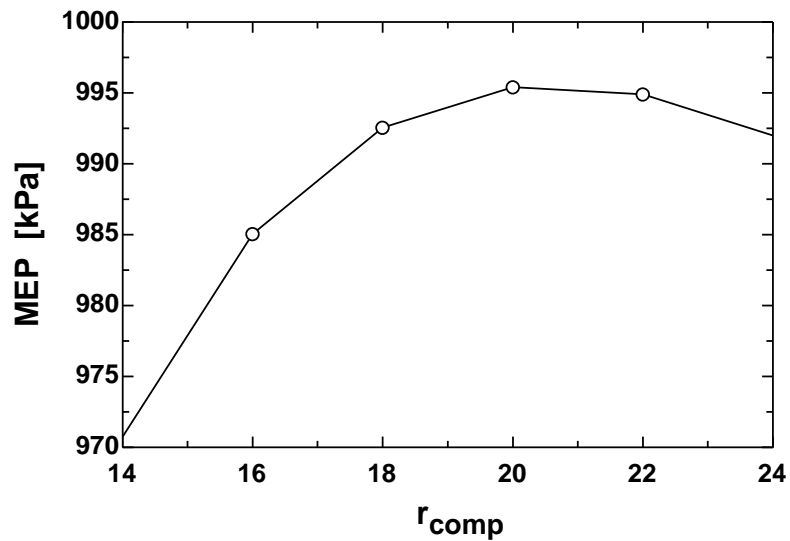
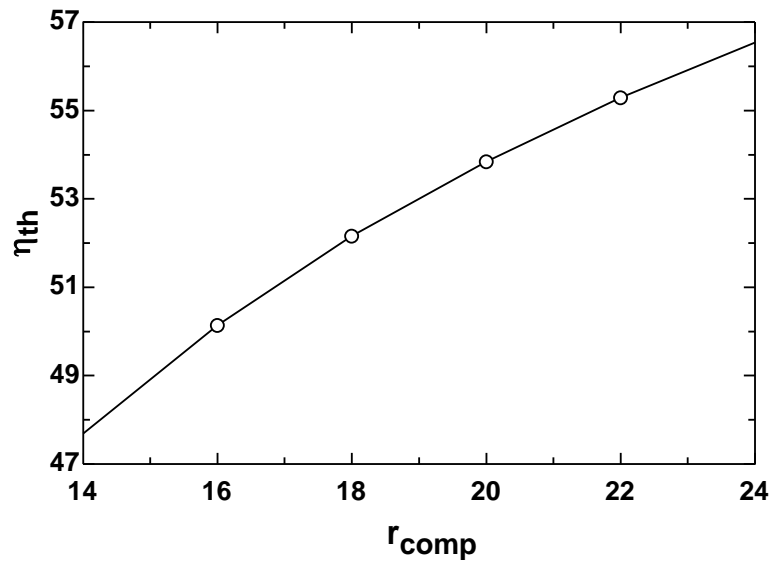
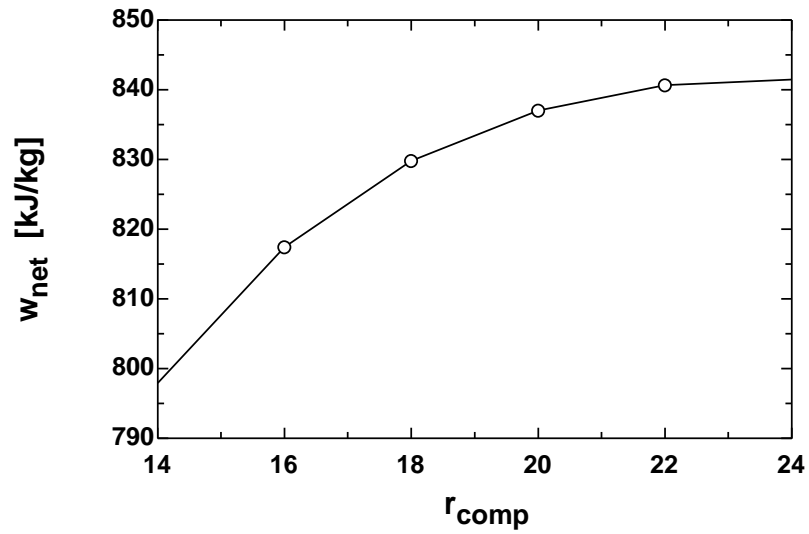

9-57 A four-cylinder ideal diesel engine with air as the working fluid has a compression ratio of 22 and a cutoff ratio of 1.8. The power the engine will deliver at 2300 rpm is to be determined.

Assumptions 1 The cold air-standard assumptions are applicable. **2** Kinetic and potential energy changes are negligible. **3** Air is an ideal gas with constant specific heats.

Properties The properties of air at room temperature are $c_p = 1.005 \text{ kJ/kg}\cdot\text{K}$, $c_v = 0.718 \text{ kJ/kg}\cdot\text{K}$, $R = 0.287 \text{ kJ/kg}\cdot\text{K}$, and $k = 1.4$ (Table A-2).

Analysis Process 1-2: isentropic compression.

$$T_2 = T_1 \left(\frac{v_1}{v_2} \right)^{k-1} = (343 \text{ K})(22)^{0.4} = 1181 \text{ K}$$

Process 2-3: $P = \text{constant}$ heat addition.

$$\frac{P_3 v_3}{T_3} = \frac{P_2 v_2}{T_2} \longrightarrow T_3 = \frac{v_3}{v_2} T_2 = 1.8 T_2 = (1.8)(1181 \text{ K}) = 2126 \text{ K}$$

Process 3-4: isentropic expansion.

$$T_4 = T_3 \left(\frac{v_3}{v_4} \right)^{k-1} = T_3 \left(\frac{2.2 v_2}{v_4} \right)^{k-1} = T_3 \left(\frac{2.2}{r} \right)^{k-1} = (2216 \text{ K}) \left(\frac{1.8}{22} \right)^{0.4} = 781 \text{ K}$$

For the cycle:

$$m = \frac{P_1 v_1}{RT_1} = \frac{(97 \text{ kPa})(0.0024 \text{ m}^3)}{(0.287 \text{ kPa}\cdot\text{m}^3/\text{kg}\cdot\text{K})(343 \text{ K})} = 0.002365 \text{ kg}$$

$$\begin{aligned} Q_{\text{in}} &= m(h_3 - h_2) = mc_p(T_3 - T_2) \\ &= (0.002365 \text{ kg})(1.005 \text{ kJ/kg}\cdot\text{K})(2216 - 1181)\text{K} \\ &= 2.246 \text{ kJ} \end{aligned}$$

$$\begin{aligned} Q_{\text{out}} &= m(u_4 - u_1) = mc_v(T_4 - T_1) \\ &= (0.002365 \text{ kg})(0.718 \text{ kJ/kg}\cdot\text{K})(781 - 343)\text{K} \\ &= 0.7438 \text{ kJ} \end{aligned}$$

$$W_{\text{net,out}} = Q_{\text{in}} - Q_{\text{out}} = 2.246 - 0.7438 = 1.502 \text{ kJ/rev}$$

$$\dot{W}_{\text{net,out}} = \dot{n} W_{\text{net,out}} = (3500/60 \text{ rev/s})(1.502 \text{ kJ/rev}) = \mathbf{87.6 \text{ kW}}$$

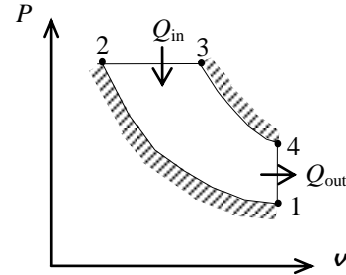

Discussion Note that for 2-stroke engines, 1 thermodynamic cycle is equivalent to 1 mechanical cycle (and thus revolutions).

9-58 A four-cylinder ideal diesel engine with nitrogen as the working fluid has a compression ratio of 22 and a cutoff ratio of 1.8. The power the engine will deliver at 2300 rpm is to be determined.

Assumptions 1 The air-standard assumptions are applicable with nitrogen as the working fluid. **2** Kinetic and potential energy changes are negligible. **3** Nitrogen is an ideal gas with constant specific heats.

Properties The properties of nitrogen at room temperature are $c_p = 1.039 \text{ kJ/kg}\cdot\text{K}$, $c_v = 0.743 \text{ kJ/kg}\cdot\text{K}$, $R = 0.2968 \text{ kJ/kg}\cdot\text{K}$, and $k = 1.4$ (Table A-2).

Analysis Process 1-2: isentropic compression.

$$T_2 = T_1 \left(\frac{v_1}{v_2} \right)^{k-1} = (343 \text{ K})(22)^{0.4} = 1181 \text{ K}$$

Process 2-3: $P = \text{constant}$ heat addition.

$$\frac{P_3 v_3}{T_3} = \frac{P_2 v_2}{T_2} \longrightarrow T_3 = \frac{v_3}{v_2} T_2 = 1.8 T_2 = (1.8)(1181 \text{ K}) = 2126 \text{ K}$$

Process 3-4: isentropic expansion.

$$T_4 = T_3 \left(\frac{v_3}{v_4} \right)^{k-1} = T_3 \left(\frac{2.2 v_2}{v_4} \right)^{k-1} = T_3 \left(\frac{2.2}{r} \right)^{k-1} = (2126 \text{ K}) \left(\frac{1.8}{22} \right)^{0.4} = 781 \text{ K}$$

For the cycle:

$$m = \frac{P_1 v_1}{RT_1} = \frac{(97 \text{ kPa})(0.0024 \text{ m}^3)}{(0.2968 \text{ kPa}\cdot\text{m}^3/\text{kg}\cdot\text{K})(343 \text{ K})} = 0.002287 \text{ kg}$$

$$\begin{aligned} Q_{\text{in}} &= m(h_3 - h_2) = mc_p(T_3 - T_2) \\ &= (0.002287 \text{ kg})(1.039 \text{ kJ/kg}\cdot\text{K})(2126 - 1181) \text{ K} \\ &= 2.245 \text{ kJ} \end{aligned}$$

$$\begin{aligned} Q_{\text{out}} &= m(u_4 - u_1) = mc_v(T_4 - T_1) \\ &= (0.002287 \text{ kg})(0.743 \text{ kJ/kg}\cdot\text{K})(781 - 343) \text{ K} \\ &= 0.7443 \text{ kJ} \end{aligned}$$

$$W_{\text{net,out}} = Q_{\text{in}} - Q_{\text{out}} = 2.245 - 0.7443 = 1.501 \text{ kJ/rev}$$

$$\dot{W}_{\text{net,out}} = \dot{n} W_{\text{net,out}} = (3500/60 \text{ rev/s})(1.501 \text{ kJ/rev}) = \mathbf{87.5 \text{ kW}}$$

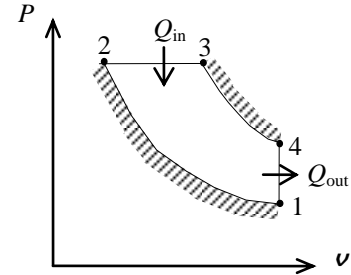

Discussion Note that for 2-stroke engines, 1 thermodynamic cycle is equivalent to 1 mechanical cycle (and thus revolutions).

9-59E An ideal dual cycle has a compression ratio of 15 and cutoff ratio of 1.4. The net work, heat addition, and the thermal efficiency are to be determined.

Assumptions 1 The air-standard assumptions are applicable. **2** Kinetic and potential energy changes are negligible. **3** Air is an ideal gas with constant specific heats.

Properties The properties of air at room temperature are $R = 0.3704 \text{ psia} \cdot \text{ft}^3/\text{lbm} \cdot \text{R}$ (Table A-1E), $c_p = 0.240 \text{ Btu}/\text{lbm} \cdot \text{R}$, $c_v = 0.171 \text{ Btu}/\text{lbm} \cdot \text{R}$, and $k = 1.4$ (Table A-2Ea).

Analysis Working around the cycle, the germane properties at the various states are

$$T_2 = T_1 \left(\frac{v_1}{v_2} \right)^{k-1} = T_1 r^{k-1} = (535 \text{ R})(15)^{1.4-1} = 1580 \text{ R}$$

$$P_2 = P_1 \left(\frac{v_1}{v_2} \right)^k = P_1 r^k = (14.2 \text{ psia})(15)^{1.4} = 629.2 \text{ psia}$$

$$P_x = P_3 = r_p P_2 = (1.1)(629.2 \text{ psia}) = 692.1 \text{ psia}$$

$$T_x = T_2 \left(\frac{P_x}{P_2} \right) = (1580 \text{ R}) \left(\frac{692.1 \text{ psia}}{629.2 \text{ psia}} \right) = 1738 \text{ R}$$

$$T_3 = T_x \left(\frac{v_3}{v_x} \right) = T_x r_c = (1738 \text{ R})(1.4) = 2433 \text{ R}$$

$$T_4 = T_3 \left(\frac{v_3}{v_4} \right)^{k-1} = T_3 \left(\frac{r_c}{r} \right)^{k-1} = (2433 \text{ R}) \left(\frac{1.4}{15} \right)^{1.4-1} = 942.2 \text{ R}$$

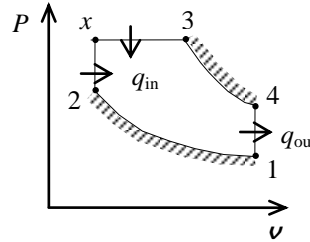

Applying the first law to each of the processes gives

$$w_{1-2} = c_v(T_2 - T_1) = (0.171 \text{ Btu}/\text{lbm} \cdot \text{R})(1580 - 535)\text{R} = 178.7 \text{ Btu}/\text{lbm}$$

$$q_{2-x} = c_v(T_x - T_2) = (0.171 \text{ Btu}/\text{lbm} \cdot \text{R})(1738 - 1580)\text{R} = 27.02 \text{ Btu}/\text{lbm}$$

$$q_{x-3} = c_p(T_3 - T_x) = (0.240 \text{ Btu}/\text{lbm} \cdot \text{R})(2433 - 1738)\text{R} = 166.8 \text{ Btu}/\text{lbm}$$

$$w_{x-3} = q_{x-3} - c_v(T_3 - T_x) = 166.8 \text{ Btu}/\text{lbm} - (0.171 \text{ Btu}/\text{lbm} \cdot \text{R})(2433 - 1738)\text{R} = 47.96 \text{ Btu}/\text{lbm}$$

$$w_{3-4} = c_v(T_3 - T_4) = (0.171 \text{ Btu}/\text{lbm} \cdot \text{R})(2433 - 942.2)\text{R} = 254.9 \text{ Btu}/\text{lbm}$$

The net work of the cycle is

$$w_{\text{net}} = w_{3-4} + w_{x-3} - w_{1-2} = 254.9 + 47.96 - 178.7 = \mathbf{124.2 \text{ Btu}/\text{lbm}}$$

and the net heat addition is

$$q_{\text{in}} = q_{2-x} + q_{x-3} = 27.02 + 166.8 = \mathbf{193.8 \text{ Btu}/\text{lbm}}$$

Hence, the thermal efficiency is

$$\eta_{\text{th}} = \frac{w_{\text{net}}}{q_{\text{in}}} = \frac{124.2 \text{ Btu}/\text{lbm}}{193.8 \text{ Btu}/\text{lbm}} = \mathbf{0.641}$$



9-60 An ideal dual cycle with air as the working fluid has a compression ratio of 14. The fraction of heat transferred at constant volume and the thermal efficiency of the cycle are to be determined.

Assumptions **1** The air-standard assumptions are applicable. **2** Kinetic and potential energy changes are negligible. **3** Air is an ideal gas with variable specific heats.

Properties The properties of air are given in Table A-17.

Analysis (a) Process 1-2: isentropic compression.

$$T_1 = 300 \text{ K} \longrightarrow \begin{aligned} u_1 &= 214.07 \text{ kJ/kg} \\ v_{r_1} &= 621.2 \end{aligned}$$

$$v_{r_2} = \frac{v_2}{v_1} v_{r_1} = \frac{1}{r} v_{r_1} = \frac{1}{14} (621.2) = 44.37 \longrightarrow \begin{aligned} T_2 &= 823.1 \text{ K} \\ u_2 &= 611.2 \text{ kJ/kg} \end{aligned}$$

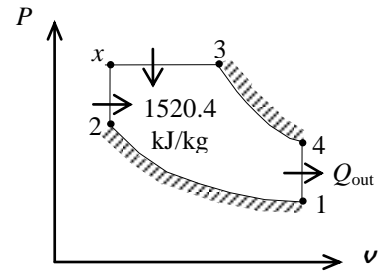

Process 2-x, x-3: heat addition,

$$T_3 = 2200 \text{ K} \longrightarrow \begin{aligned} h_3 &= 2503.2 \text{ kJ/kg} \\ v_{r_3} &= 2.012 \end{aligned}$$

$$\begin{aligned} q_{\text{in}} &= q_{2-x,\text{in}} + q_{3-x,\text{in}} = (u_x - u_2) + (h_3 - h_x) \\ 1520.4 &= (u_x - 611.2) + (2503.2 - h_x) \end{aligned}$$

By trial and error, we get

$$T_x = 1300 \text{ K} \text{ and } h_x = 1395.97, u_x = 1022.82 \text{ kJ/kg.}$$

Thus,

$$q_{2-x,\text{in}} = u_x - u_2 = 1022.82 - 611.2 = 411.62 \text{ kJ/kg}$$

and

$$\text{ratio} = \frac{q_{2-x,\text{in}}}{q_{\text{in}}} = \frac{411.62 \text{ kJ/kg}}{1520.4 \text{ kJ/kg}} = \mathbf{27.1\%}$$

$$(b) \quad \frac{P_3 v_3}{T_3} = \frac{P_x v_x}{T_x} \longrightarrow \frac{v_3}{v_x} = \frac{T_3}{T_x} = \frac{2200 \text{ K}}{1300 \text{ K}} = 1.692 = r_c$$

$$v_{r_4} = \frac{v_4}{v_3} v_{r_3} = \frac{v_4}{1.692 v_3} v_{r_3} = \frac{r}{1.692} v_{r_3} = \frac{14}{1.692} (2.012) = 16.648 \longrightarrow u_4 = 886.3 \text{ kJ/kg}$$

Process 4-1: $v = \text{constant}$ heat rejection.

$$q_{\text{out}} = u_4 - u_1 = 886.3 - 214.07 = 672.23 \text{ kJ/kg}$$

$$\eta_{\text{th}} = 1 - \frac{q_{\text{out}}}{q_{\text{in}}} = 1 - \frac{672.23 \text{ kJ/kg}}{1520.4 \text{ kJ/kg}} = \mathbf{55.8\%}$$



9-61 Problem 9-60 is reconsidered. The effect of the compression ratio on the net work output and thermal efficiency is to be investigated. Also, T - s and P - v diagrams for the cycle are to be plotted.

Analysis Using EES, the problem is solved as follows:

"Input Data"

T[1]=300 [K]
 P[1]=100 [kPa]
 T[4]=2200 [K]
 q_in_total=1520 [kJ/kg]
 r_v = 14
 v[1]/v[2]=r_v "Compression ratio"

"Process 1-2 is isentropic compression"

s[1]=entropy(air, T=T[1], P=P[1])
 s[2]=s[1]
 s[2]=entropy(air, T=T[2], v=v[2])
 P[2]*v[2]/T[2]=P[1]*v[1]/T[1]
 P[1]*v[1]=R*T[1]
 R=0.287 [kJ/kg-K]

"Conservation of energy for process 1 to 2"

q_12 -w_12 = DELTAu_12
 q_12 =0 [kJ/kg] "isentropic process"
 DELTAu_12=intenergy(air, T=T[2])-intenergy(air, T=T[1])

"Process 2-3 is constant volume heat addition"

s[3]=entropy(air, T=T[3], P=P[3])
 {P[3]*v[3]/T[3]=P[2]*v[2]/T[2]}
 P[3]*v[3]=R*T[3]
 v[3]=v[2]

"Conservation of energy for process 2 to 3"

q_23 -w_23 = DELTAu_23
 w_23 =0 "constant volume process"
 DELTAu_23=intenergy(air, T=T[3])-intenergy(air, T=T[2])

"Process 3-4 is constant pressure heat addition"

s[4]=entropy(air, T=T[4], P=P[4])
 {P[4]*v[4]/T[4]=P[3]*v[3]/T[3]}
 P[4]*v[4]=R*T[4]
 P[4]=P[3]

"Conservation of energy for process 3 to 4"

q_34 -w_34 = DELTAu_34
 w_34 =P[3]*(v[4]-v[3]) "constant pressure process"
 DELTAu_34=intenergy(air, T=T[4])-intenergy(air, T=T[3])
 q_in_total=q_23+q_34

"Process 4-5 is isentropic expansion"

s[5]=entropy(air, T=T[5], P=P[5])
 s[5]=s[4]
 P[5]*v[5]/T[5]=P[4]*v[4]/T[4]
 {P[5]*v[5]=0.287*T[5]}

"Conservation of energy for process 4 to 5"

q_45 -w_45 = DELTAu_45
 q_45 =0 [kJ/kg] "isentropic process"
 DELTAu_45=intenergy(air, T=T[5])-intenergy(air, T=T[4])

"Process 5-1 is constant volume heat rejection"

v[5]=v[1]

"Conservation of energy for process 5 to 1"

q_51 -w_51 = DELTAu_51
 w_51 =0 [kJ/kg] "constant volume process"
 DELTAu_51=intenergy(air, T=T[1])-intenergy(air, T=T[5])

$$w_{\text{net}} = w_{12} + w_{23} + w_{34} + w_{45} + w_{51}$$

$$\text{Eta}_{\text{th}} = w_{\text{net}} / q_{\text{in_total}} * \text{Convert}(, \%)$$
 "Thermal efficiency, in percent"

r_v	η_{th} [%]	w_{net} [kJ/kg]
10	52.33	795.4
11	53.43	812.1
12	54.34	826
13	55.09	837.4
14	55.72	846.9
15	56.22	854.6
16	56.63	860.7
17	56.94	865.5
18	57.17	869

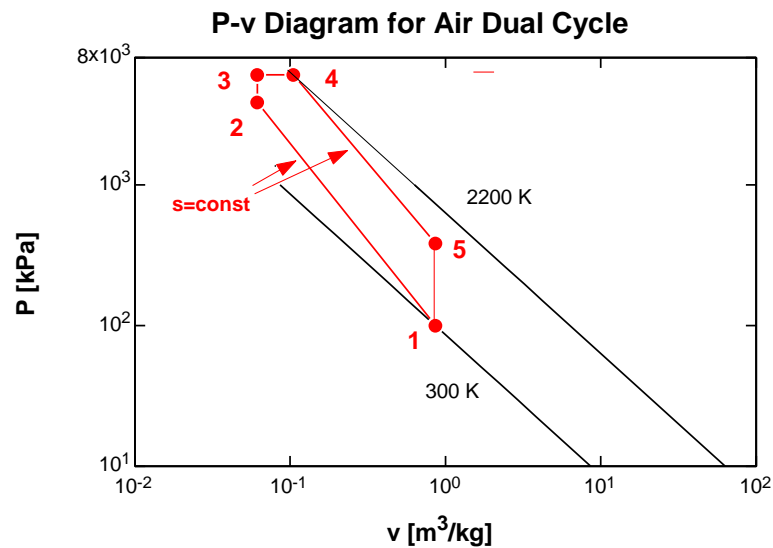
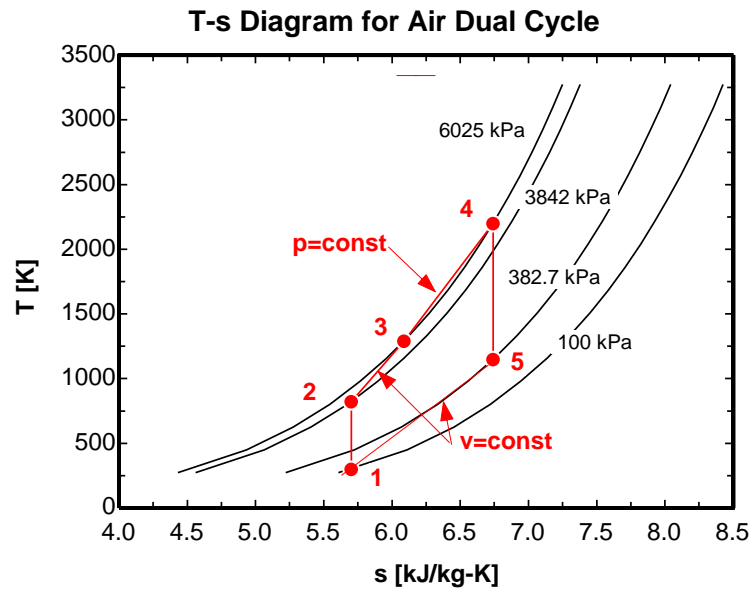

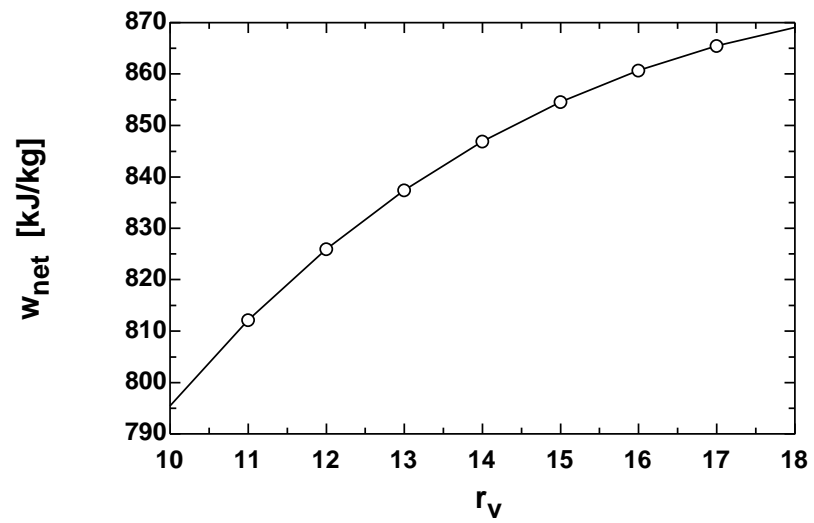
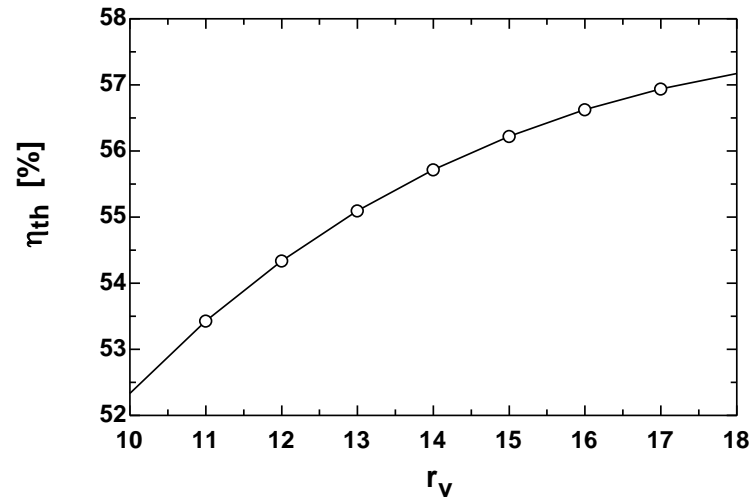

9-62 An ideal dual cycle with air as the working fluid has a compression ratio of 14. The fraction of heat transferred at constant volume and the thermal efficiency of the cycle are to be determined.

Assumptions 1 The air-standard assumptions are applicable. **2** Kinetic and potential energy changes are negligible. **3** Air is an ideal gas with constant specific heats.

Properties The properties of air at room temperature are $c_p = 1.005 \text{ kJ/kg}\cdot\text{K}$, $c_v = 0.718 \text{ kJ/kg}\cdot\text{K}$, and $k = 1.4$ (Table A-2).

Analysis (a) Process 1-2: isentropic compression.

$$T_2 = T_1 \left(\frac{v_1}{v_2} \right)^{k-1} = (300 \text{ K})(14)^{0.4} = 862 \text{ K}$$

Process 2- x , x -3: heat addition,

$$\begin{aligned} q_{\text{in}} &= q_{2-x,\text{in}} + q_{3-x,\text{in}} = (u_x - u_2) + (h_3 - h_x) \\ &= c_v(T_x - T_2) + c_p(T_3 - T_x) \\ 1520.4 \text{ kJ/kg} &= (0.718 \text{ kJ/kg}\cdot\text{K})(T_x - 862) + (1.005 \text{ kJ/kg}\cdot\text{K})(2200 - T_x) \end{aligned}$$

Solving for T_x we get $T_x = 250 \text{ K}$ which is impossible. Therefore, constant specific heats at room temperature turned out to be an unreasonable assumption in this case because of the very high temperatures involved.

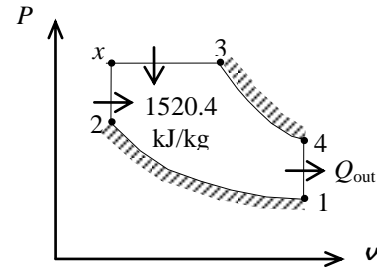

9-63 An expression for cutoff ratio of an ideal diesel cycle is to be developed.

Assumptions 1 The air-standard assumptions are applicable. **2** Kinetic and potential energy changes are negligible. **3** Air is an ideal gas with constant specific heats.

Analysis Employing the isentropic process equations,

$$T_2 = T_1 r^{k-1}$$

while the ideal gas law gives

$$T_3 = T_2 r_c = r_c r^{k-1} T_1$$

When the first law and the closed system work integral is applied to the constant pressure heat addition, the result is

$$q_{\text{in}} = c_p(T_3 - T_2) = c_p(r_c r^{k-1} T_1 - r^{k-1} T_1)$$

When this is solved for cutoff ratio, the result is

$$r_c = 1 + \frac{q_{\text{in}}}{c_p r^{k-1} T_1}$$

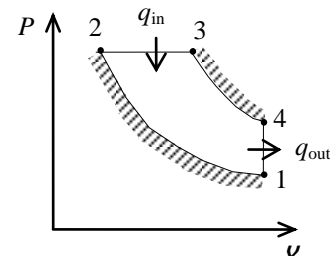

9-64 The five processes of the dual cycle is described. The P - v and T - s diagrams for this cycle is to be sketched. An expression for the cycle thermal efficiency is to be obtained and the limit of the efficiency is to be evaluated for certain cases.

Assumptions 1 The air-standard assumptions are applicable. **2** Kinetic and potential energy changes are negligible. **3** Air is an ideal gas with constant specific heats.

Analysis (a) The P - v and T - s diagrams for this cycle are as shown.

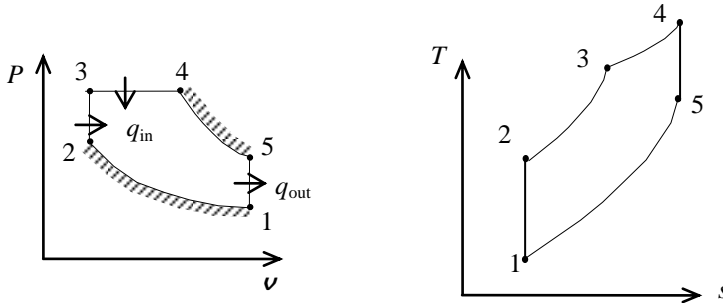

(b) Apply first law to the closed system for processes 2-3, 3-4, and 5-1 to show:

$$q_{in} = C_v(T_3 - T_2) + C_p(T_4 - T_3)$$

$$q_{out} = C_v(T_5 - T_1)$$

The cycle thermal efficiency is given by

$$\eta_{th} = 1 - \frac{q_{out}}{q_{in}} = 1 - \frac{C_v(T_5 - T_1)}{C_v(T_3 - T_2) + C_p(T_4 - T_3)} = 1 - \frac{T_1(T_5/T_1 - 1)}{T_2(T_3/T_2 - 1) + kT_3(T_4/T_3 - 1)}$$

$$\eta_{th} = 1 - \frac{(T_5/T_1 - 1)}{\frac{T_2}{T_1}(T_3/T_2 - 1) + k\frac{T_3}{T_1}(T_4/T_3 - 1)}$$

Process 1-2 is isentropic; therefore,

$$\frac{T_2}{T_1} = \left(\frac{V_1}{V_2}\right)^{k-1} = r^{k-1}$$

Process 2-3 is constant volume; therefore,

$$\frac{T_3}{T_2} = \frac{P_3 V_3}{P_2 V_2} = \frac{P_3}{P_2} = r_p$$

Process 3-4 is constant pressure; therefore,

$$\frac{P_4 V_4}{T_4} = \frac{P_3 V_3}{T_3} \Rightarrow \frac{T_4}{T_3} = \frac{V_4}{V_3} = r_c$$

Process 4-5 is isentropic; therefore,

$$\frac{T_5}{T_4} = \left(\frac{V_4}{V_5}\right)^{k-1} = \left(\frac{V_4}{V_1}\right)^{k-1} = \left(\frac{r_c V_3}{V_1}\right)^{k-1} = \left(\frac{r_c V_2}{V_1}\right)^{k-1} = \left(\frac{r_c}{r}\right)^{k-1}$$

Process 5-1 is constant volume; however T_5/T_1 is found from the following.

$$\frac{T_5}{T_1} = \frac{T_5}{T_4} \frac{T_4}{T_3} \frac{T_3}{T_2} \frac{T_2}{T_1} = \left(\frac{r_c}{r}\right)^{k-1} r_c r_p r^{k-1} = r_c^k r_p$$

The ratio T_3/T_1 is found from the following.

$$\frac{T_3}{T_1} = \frac{T_3}{T_2} \frac{T_2}{T_1} = r_p r^{k-1}$$

The efficiency becomes

$$\eta_{th} = 1 - \frac{r_c^k r_p - 1}{r^{k-1} (r_p - 1) + k r_p r^{k-1} (r_c - 1)}$$

(c) In the limit as r_p approaches unity, the cycle thermal efficiency becomes

$$\lim_{r_p \rightarrow 1} \eta_{th} = 1 - \left\{ \lim_{r_p \rightarrow 1} \frac{r_c^k r_p - 1}{r^{k-1} (r_p - 1) + k r_p r^{k-1} (r_c - 1)} \right\}$$

$$\lim_{r_p \rightarrow 1} \eta_{th} = 1 - \frac{1}{r^{k-1}} \left[\frac{r_c^k - 1}{k (r_c - 1)} \right] = \eta_{th \text{ Diesel}}$$

(d) In the limit as r_c approaches unity, the cycle thermal efficiency becomes

$$\lim_{r_c \rightarrow 1} \eta_{th} = 1 - \left\{ \lim_{r_c \rightarrow 1} \frac{r_c^k r_p - 1}{r^{k-1} (r_p - 1) + k r_p r^{k-1} (r_c - 1)} \right\} = 1 - \left\{ \frac{r_p - 1}{r^{k-1} (r_p - 1)} \right\}$$

$$\lim_{r_c \rightarrow 1} \eta_{th} = 1 - \frac{1}{r^{k-1}} = \eta_{th \text{ Otto}}$$

Stirling and Ericsson Cycles

9-65C The Stirling cycle.

9-66C The two isentropic processes of the Carnot cycle are replaced by two constant pressure regeneration processes in the Ericsson cycle.

9-67C The efficiencies of the Carnot and the Stirling cycles would be the same, the efficiency of the Otto cycle would be less.

9-68C The efficiencies of the Carnot and the Ericsson cycles would be the same, the efficiency of the Diesel cycle would be less.

9-69E An ideal Ericsson engine with helium as the working fluid operates between the specified temperature and pressure limits. The thermal efficiency of the cycle, the heat transfer rate in the regenerator, and the power delivered are to be determined.

Assumptions Helium is an ideal gas with constant specific heats.

Properties The gas constant and the specific heat of helium at room temperature are $R = 0.4961 \text{ Btu/lbm}\cdot\text{R}$ and $c_p = 1.25 \text{ Btu/lbm}\cdot\text{R}$ (Table A-2E).

Analysis (a) The thermal efficiency of this totally reversible cycle is determined from

$$\eta_{\text{th}} = 1 - \frac{T_L}{T_H} = 1 - \frac{550\text{R}}{3000\text{R}} = \mathbf{81.67\%}$$

(b) The amount of heat transferred in the regenerator is

$$\begin{aligned}\dot{Q}_{\text{regen}} &= \dot{Q}_{41,\text{in}} = \dot{m}(h_1 - h_4) = \dot{m}c_p(T_1 - T_4) \\ &= (14 \text{ lbm/s})(1.25 \text{ Btu/lbm}\cdot\text{R})(3000 - 550)\text{R} \\ &= \mathbf{42,875 \text{ Btu/s}}\end{aligned}$$

(c) The net power output is determined from

$$s_2 - s_1 = c_p \ln \frac{T_2}{T_1} - R \ln \frac{P_2}{P_1} = -(0.4961 \text{ Btu/lbm}\cdot\text{R}) \ln \frac{25 \text{ psia}}{200 \text{ psia}} = 1.0316 \text{ Btu/lbm}\cdot\text{R}$$

$$\dot{Q}_{\text{in}} = \dot{m}T_H(s_2 - s_1) = (14 \text{ lbm/s})(3000 \text{ R})(1.0316 \text{ Btu/lbm}\cdot\text{R}) = 43,328 \text{ Btu/s}$$

$$\dot{W}_{\text{net,out}} = \eta_{\text{th}} \dot{Q}_{\text{in}} = (0.8167)(43,328) = \mathbf{35,384 \text{ Btu/s}}$$

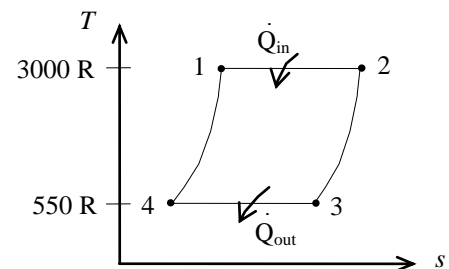

9-70 An ideal Stirling engine with helium as the working fluid operates between the specified temperature and pressure limits. The thermal efficiency of the cycle, the amount of heat transfer in the regenerator, and the work output per cycle are to be determined.

Assumptions Helium is an ideal gas with constant specific heats.

Properties The gas constant and the specific heat of helium at room temperature are $R = 2.0769 \text{ kJ/kg}\cdot\text{K}$, $c_v = 3.1156 \text{ kJ/kg}\cdot\text{K}$ and $c_p = 5.1926 \text{ kJ/kg}\cdot\text{K}$ (Table A-2).

Analysis (a) The thermal efficiency of this totally reversible cycle is determined from

$$\eta_{\text{th}} = 1 - \frac{T_L}{T_H} = 1 - \frac{300 \text{ K}}{2000 \text{ K}} = \mathbf{85.0\%}$$

(b) The amount of heat transferred in the regenerator is

$$\begin{aligned} Q_{\text{regen}} &= Q_{41\text{in}} = m(u_1 - u_4) = mc_v(T_1 - T_4) \\ &= (0.12 \text{ kg})(3.1156 \text{ kJ/kg}\cdot\text{K})(2000 - 300)\text{K} \\ &= \mathbf{635.6 \text{ kJ}} \end{aligned}$$

(c) The net work output is determined from

$$\begin{aligned} \frac{P_3 v_3}{T_3} &= \frac{P_1 v_1}{T_1} \longrightarrow \frac{v_3}{v_1} = \frac{T_3 P_1}{T_1 P_3} = \frac{(300 \text{ K})(3000 \text{ kPa})}{(2000 \text{ K})(150 \text{ kPa})} = 3 = \frac{v_2}{v_1} \\ s_2 - s_1 &= c_v \ln \frac{T_2}{T_1} + R \ln \frac{v_2}{v_1} = (2.0769 \text{ kJ/kg}\cdot\text{K}) \ln(3) = 2.282 \text{ kJ/kg}\cdot\text{K} \\ Q_{\text{in}} &= mT_H(s_2 - s_1) = (0.12 \text{ kg})(2000 \text{ K})(2.282 \text{ kJ/kg}\cdot\text{K}) = 547.6 \text{ kJ} \\ W_{\text{net,out}} &= \eta_{\text{th}} Q_{\text{in}} = (0.85)(547.6 \text{ kJ}) = \mathbf{465.5 \text{ kJ}} \end{aligned}$$

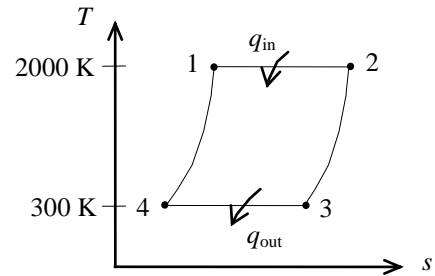

9-71 An ideal steady-flow Ericsson engine with air as the working fluid is considered. The maximum pressure in the cycle, the net work output, and the thermal efficiency of the cycle are to be determined.

Assumptions Air is an ideal gas.

Properties The gas constant of air is $R = 0.287 \text{ kJ/kg}\cdot\text{K}$ (Table A-1).

Analysis (a) The entropy change during process 3-4 is

$$s_4 - s_3 = -\frac{q_{34,\text{out}}}{T_0} = -\frac{150 \text{ kJ/kg}}{300 \text{ K}} = -0.5 \text{ kJ/kg}\cdot\text{K}$$

and

$$\begin{aligned} s_4 - s_3 &= c_p \ln \frac{T_4}{T_3} - R \ln \frac{P_4}{P_3} \\ &= -(0.287 \text{ kJ/kg}\cdot\text{K}) \ln \frac{P_4}{120 \text{ kPa}} = -0.5 \text{ kJ/kg}\cdot\text{K} \end{aligned}$$

It yields $P_4 = \mathbf{685.2 \text{ kPa}}$

(b) For reversible cycles,

$$\frac{q_{\text{out}}}{q_{\text{in}}} = \frac{T_L}{T_H} \longrightarrow q_{\text{in}} = \frac{T_H}{T_L} q_{\text{out}} = \frac{1200 \text{ K}}{300 \text{ K}} (150 \text{ kJ/kg}) = 600 \text{ kJ/kg}$$

Thus,

$$w_{\text{net,out}} = q_{\text{in}} - q_{\text{out}} = 600 - 150 = \mathbf{450 \text{ kJ/kg}}$$

(c) The thermal efficiency of this totally reversible cycle is determined from

$$\eta_{\text{th}} = 1 - \frac{T_L}{T_H} = 1 - \frac{300 \text{ K}}{1200 \text{ K}} = \mathbf{75.0\%}$$

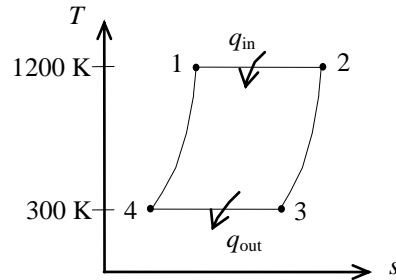

9-72E An ideal Stirling engine with air as the working fluid is considered. The temperature of the source-energy reservoir, the amount of air contained in the engine, and the maximum air pressure during the cycle are to be determined.

Assumptions Air is an ideal gas with constant specific heats.

Properties The properties of air at room temperature are $R = 0.3704 \text{ psia}\cdot\text{ft}^3/\text{lbm}\cdot\text{R}$ (Table A-1E), $c_p = 0.240 \text{ Btu/lbm}\cdot\text{R}$, $c_v = 0.171 \text{ Btu/lbm}\cdot\text{R}$, and $k = 1.4$ (Table A-2Ea).

Analysis From the thermal efficiency relation,

$$\eta_{\text{th}} = \frac{W_{\text{net}}}{Q_{\text{in}}} = 1 - \frac{T_L}{T_H} \longrightarrow \frac{2 \text{ Btu}}{5 \text{ Btu}} = 1 - \frac{535 \text{ R}}{T_H} \longrightarrow T_H = \mathbf{891.7 \text{ R}}$$

State 3 may be used to determine the mass of air in the system,

$$m = \frac{P_3 V_3}{RT_3} = \frac{(15 \text{ psia})(0.5 \text{ ft}^3)}{(0.3704 \text{ psia}\cdot\text{ft}^3/\text{lbm}\cdot\text{R})(535 \text{ R})} = \mathbf{0.03785 \text{ lbm}}$$

The maximum pressure occurs at state 1,

$$P_1 = \frac{mRT_1}{V_1} = \frac{(0.03785 \text{ lbm})(0.3704 \text{ psia}\cdot\text{ft}^3/\text{lbm}\cdot\text{R})(891.7 \text{ R})}{0.06 \text{ ft}^3} = \mathbf{208.3 \text{ psia}}$$

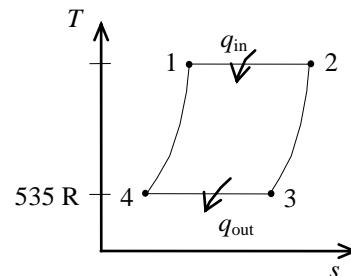

9-73E An ideal Stirling engine with air as the working fluid is considered. The temperature of the source-energy reservoir, the amount of air contained in the engine, and the maximum air pressure during the cycle are to be determined.

Assumptions Air is an ideal gas with constant specific heats.

Properties The properties of air at room temperature are $R = 0.3704 \text{ psia} \cdot \text{ft}^3/\text{lbm} \cdot \text{R}$, $c_p = 0.240 \text{ Btu}/\text{lbm} \cdot \text{R}$, $c_v = 0.171 \text{ Btu}/\text{lbm} \cdot \text{R}$, and $k = 1.4$ (Table A-2E).

Analysis From the thermal efficiency relation,

$$\eta_{\text{th}} = \frac{W_{\text{net}}}{Q_{\text{in}}} = 1 - \frac{T_L}{T_H} \longrightarrow \frac{2.5 \text{ Btu}}{5 \text{ Btu}} = 1 - \frac{535 \text{ R}}{T_H} \longrightarrow T_H = \mathbf{1070 \text{ R}}$$

State 3 may be used to determine the mass of air in the system,

$$m = \frac{P_3 V_3}{RT_3} = \frac{(15 \text{ psia})(0.5 \text{ ft}^3)}{(0.3704 \text{ psia} \cdot \text{ft}^3/\text{lbm} \cdot \text{R})(535 \text{ R})} = \mathbf{0.03785 \text{ lbm}}$$

The maximum pressure occurs at state 1,

$$P_1 = \frac{mRT_1}{V_1} = \frac{(0.03785 \text{ lbm})(0.3704 \text{ psia} \cdot \text{ft}^3/\text{lbm} \cdot \text{R})(1070 \text{ R})}{0.06 \text{ ft}^3} = \mathbf{250 \text{ psia}}$$

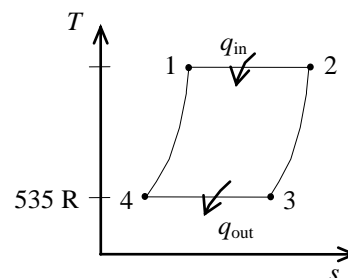

9-74 An ideal Stirling engine with air as the working fluid operates between specified pressure limits. The heat added to the cycle and the net work produced by the cycle are to be determined.

Assumptions Air is an ideal gas with constant specific heats.

Properties The properties of air at room temperature are $R = 0.287 \text{ kPa} \cdot \text{m}^3/\text{kg} \cdot \text{K}$, $c_p = 1.005 \text{ kJ}/\text{kg} \cdot \text{K}$, $c_v = 0.718 \text{ kJ}/\text{kg} \cdot \text{K}$, and $k = 1.4$ (Table A-2a).

Analysis Applying the ideal gas equation to the isothermal process 3-4 gives

$$P_4 = P_3 \frac{v_3}{v_4} = (50 \text{ kPa})(12) = 600 \text{ kPa}$$

Since process 4-1 is one of constant volume,

$$T_1 = T_4 \left(\frac{P_1}{P_4} \right) = (298 \text{ K}) \left(\frac{3600 \text{ kPa}}{600 \text{ kPa}} \right) = 1788 \text{ K}$$

Adapting the first law and work integral to the heat addition process gives

$$q_{\text{in}} = w_{1-2} = RT_1 \ln \frac{v_2}{v_1} = (0.287 \text{ kJ}/\text{kg} \cdot \text{K})(1788 \text{ K}) \ln(12) = \mathbf{1275 \text{ kJ}/\text{kg}}$$

Similarly,

$$q_{\text{out}} = w_{3-4} = RT_3 \ln \frac{v_4}{v_3} = (0.287 \text{ kJ}/\text{kg} \cdot \text{K})(298 \text{ K}) \ln \left(\frac{1}{12} \right) = \mathbf{212.5 \text{ kJ}/\text{kg}}$$

The net work is then

$$w_{\text{net}} = q_{\text{in}} - q_{\text{out}} = 1275 - 212.5 = \mathbf{1063 \text{ kJ}/\text{kg}}$$

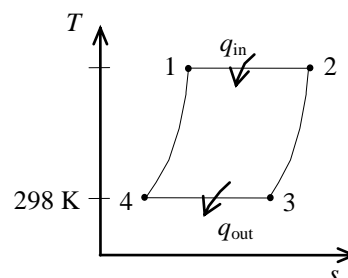

9-75 An ideal Stirling engine with air as the working fluid operates between specified pressure limits. The heat transfer in the regenerator is to be determined.

Assumptions Air is an ideal gas with constant specific heats.

Properties The properties of air at room temperature are $R = 0.287 \text{ kPa} \cdot \text{m}^3/\text{kg} \cdot \text{K}$, $c_p = 1.005 \text{ kJ/kg} \cdot \text{K}$, $c_v = 0.718 \text{ kJ/kg} \cdot \text{K}$, and $k = 1.4$ (Table A-2a).

Analysis Applying the ideal gas equation to the isothermal process 3-4 gives

$$P_4 = P_3 \frac{v_3}{v_4} = (50 \text{ kPa})(12) = 600 \text{ kPa}$$

Since process 4-1 is one of constant volume,

$$T_1 = T_4 \left(\frac{P_1}{P_4} \right) = (298 \text{ K}) \left(\frac{3600 \text{ kPa}}{600 \text{ kPa}} \right) = 1788 \text{ K}$$

Application of the first law to process 4-1 gives

$$q_{\text{regen}} = c_v(T_1 - T_4) = (0.718 \text{ kJ/kg} \cdot \text{K})(1788 - 298) \text{ K} = \mathbf{1070 \text{ kJ/kg}}$$

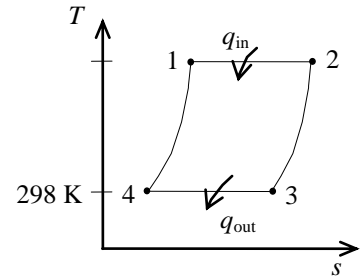

Ideal and Actual Gas-Turbine (Brayton) Cycles

9-76C For fixed maximum and minimum temperatures, (a) the thermal efficiency increases with pressure ratio, (b) the net work first increases with pressure ratio, reaches a maximum, and then decreases.

9-77C Back work ratio is the ratio of the compressor (or pump) work input to the turbine work output. It is usually between 0.40 and 0.6 for gas turbine engines.

9-78C In gas turbine engines a gas is compressed, and thus the compression work requirements are very large since the steady-flow work is proportional to the specific volume.

9-79C As a result of turbine and compressor inefficiencies, (a) the back work ratio increases, and (b) the thermal efficiency decreases.

9-80E A simple ideal Brayton cycle with air as the working fluid has a pressure ratio of 10. The air temperature at the compressor exit, the back work ratio, and the thermal efficiency are to be determined.

Assumptions 1 Steady operating conditions exist. 2 The air-standard assumptions are applicable. 3 Kinetic and potential energy changes are negligible. 4 Air is an ideal gas with variable specific heats.

Properties The properties of air are given in Table A-17E.

Analysis (a) Noting that process 1-2 is isentropic,

$$T_1 = 520 \text{ R} \longrightarrow \begin{array}{l} h_1 = 124.27 \text{ Btu/lbm} \\ P_{r_1} = 1.2147 \end{array}$$

$$P_{r_2} = \frac{P_2}{P_1} P_{r_1} = (10)(1.2147) = 12.147 \longrightarrow \begin{array}{l} T_2 = \mathbf{996.5 \text{ R}} \\ h_2 = 240.11 \text{ Btu/lbm} \end{array}$$

(b) Process 3-4 is isentropic, and thus

$$T_3 = 2000 \text{ R} \longrightarrow \begin{array}{l} h_3 = 504.71 \text{ Btu/lbm} \\ P_{r_3} = 174.0 \end{array}$$

$$P_{r_4} = \frac{P_4}{P_3} P_{r_3} = \left(\frac{1}{10}\right)(174.0) = 17.4 \longrightarrow h_4 = 265.83 \text{ Btu/lbm}$$

$$w_{C,\text{in}} = h_2 - h_1 = 240.11 - 124.27 = 115.84 \text{ Btu/lbm}$$

$$w_{T,\text{out}} = h_3 - h_4 = 504.71 - 265.83 = 238.88 \text{ Btu/lbm}$$

Then the back-work ratio becomes

$$r_{\text{bw}} = \frac{w_{C,\text{in}}}{w_{T,\text{out}}} = \frac{115.84 \text{ Btu/lbm}}{238.88 \text{ Btu/lbm}} = \mathbf{48.5\%}$$

(c) $q_{\text{in}} = h_3 - h_2 = 504.71 - 240.11 = 264.60 \text{ Btu/lbm}$

$$w_{\text{net,out}} = w_{T,\text{out}} - w_{C,\text{in}} = 238.88 - 115.84 = 123.04 \text{ Btu/lbm}$$

$$\eta_{\text{th}} = \frac{w_{\text{net,out}}}{q_{\text{in}}} = \frac{123.04 \text{ Btu/lbm}}{264.60 \text{ Btu/lbm}} = \mathbf{46.5\%}$$

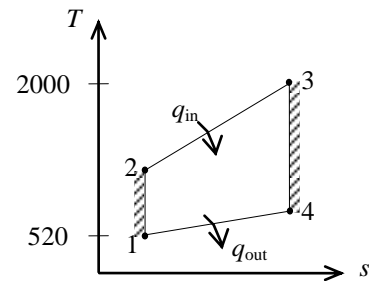

9-81 A 32-MW gas-turbine power plant operates on a simple Brayton cycle with air as the working fluid. The mass flow rate of air through the cycle is to be determined.

Assumptions 1 Steady operating conditions exist. 2 The air-standard assumptions are applicable. 3 Kinetic and potential energy changes are negligible. 4 Air is an ideal gas with variable specific heats.

Properties The properties of air are given in Table A-17.

Analysis Using variable specific heats,

$$T_1 = 310 \text{ K} \longrightarrow \begin{aligned} h_1 &= 310.24 \text{ kJ/kg} \\ P_{r_1} &= 1.5546 \end{aligned}$$

$$P_{r_2} = \frac{P_2}{P_1} P_{r_1} = (8)(1.5546) = 12.44 \longrightarrow h_{2s} = 562.26 \text{ kJ/kg}$$

$$T_3 = 900 \text{ K} \longrightarrow \begin{aligned} h_3 &= 932.93 \text{ kJ/kg} \\ P_{r_3} &= 75.29 \end{aligned}$$

$$P_{r_4} = \frac{P_4}{P_3} P_{r_3} = \left(\frac{1}{8}\right)(75.29) = 9.411 \longrightarrow h_{4s} = 519.32 \text{ kJ/kg}$$

$$\begin{aligned} w_{\text{net,out}} &= w_{T,\text{out}} - w_{C,\text{in}} = \eta_T (h_3 - h_{4s}) - (h_{2s} - h_1) / \eta_C \\ &= (0.86)(932.93 - 519.32) - (562.26 - 310.24) / (0.80) \\ &= 40.68 \text{ kJ/kg} \end{aligned}$$

and

$$\dot{m} = \frac{\dot{W}_{\text{net,out}}}{w_{\text{net,out}}} = \frac{32,000 \text{ kJ/s}}{40.68 \text{ kJ/kg}} = \mathbf{786.6 \text{ kg/s}}$$

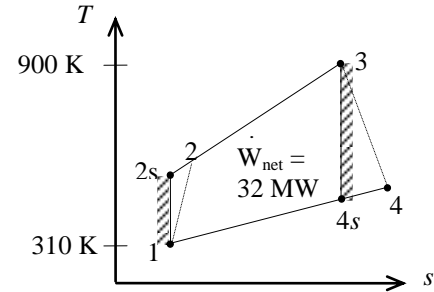

9-82 A 32-MW gas-turbine power plant operates on a simple Brayton cycle with air as the working fluid. The mass flow rate of air through the cycle is to be determined.

Assumptions 1 Steady operating conditions exist. 2 The air-standard assumptions are applicable. 3 Kinetic and potential energy changes are negligible. 4 Air is an ideal gas with constant specific heats.

Properties The properties of air at room temperature are $c_p = 1.005 \text{ kJ/kg}\cdot\text{K}$ and $k = 1.4$ (Table A-2).

Analysis Using constant specific heats,

$$T_{2s} = T_1 \left(\frac{P_2}{P_1}\right)^{(k-1)/k} = (310 \text{ K})(8)^{0.4/1.4} = 561.5 \text{ K}$$

$$T_{4s} = T_3 \left(\frac{P_4}{P_3}\right)^{(k-1)/k} = (900 \text{ K})\left(\frac{1}{8}\right)^{0.4/1.4} = 496.8 \text{ K}$$

$$\begin{aligned} w_{\text{net,out}} &= w_{T,\text{out}} - w_{C,\text{in}} = \eta_T c_p (T_3 - T_{4s}) - c_p (T_{2s} - T_1) / \eta_C \\ &= (1.005 \text{ kJ/kg}\cdot\text{K})[(0.86)(900 - 496.8) - (561.5 - 310) / (0.80)] \text{ K} \\ &= 32.5 \text{ kJ/kg} \end{aligned}$$

and

$$\dot{m} = \frac{\dot{W}_{\text{net,out}}}{w_{\text{net,out}}} = \frac{32,000 \text{ kJ/s}}{32.5 \text{ kJ/kg}} = \mathbf{984.6 \text{ kg/s}}$$

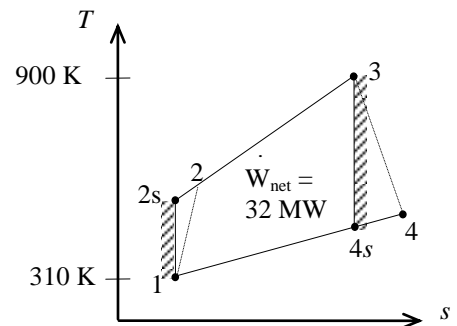



9-83 A simple Brayton cycle with air as the working fluid has a pressure ratio of 10. The air temperature at the turbine exit, the net work output, and the thermal efficiency are to be determined.

Assumptions 1 Steady operating conditions exist. 2 The air-standard assumptions are applicable. 3 Kinetic and potential energy changes are negligible. 4 Air is an ideal gas with variable specific heats.

Properties The properties of air are given in Table A-17.

Analysis (a) Noting that process 1-2s is isentropic,

$$T_1 = 295 \text{ K} \longrightarrow \begin{aligned} h_1 &= 295.17 \text{ kJ/kg} \\ P_{r_1} &= 1.3068 \end{aligned}$$

$$P_{r_2} = \frac{P_2}{P_1} P_{r_1} = (10)(1.3068) = 13.07 \longrightarrow h_{2s} = 570.26 \text{ kJ/kg} \text{ and } T_{2s} = 564.9 \text{ K}$$

$$\begin{aligned} \eta_C &= \frac{h_{2s} - h_1}{h_2 - h_1} \longrightarrow h_2 = h_1 + \frac{h_{2s} - h_1}{\eta_C} \\ &= 295.17 + \frac{570.26 - 295.17}{0.83} = 626.60 \text{ kJ/kg} \end{aligned}$$

$$T_3 = 1240 \text{ K} \longrightarrow \begin{aligned} h_3 &= 1324.93 \text{ kJ/kg} \\ P_{r_3} &= 272.3 \end{aligned}$$

$$P_{r_4} = \frac{P_4}{P_3} P_{r_3} = \left(\frac{1}{10}\right)(272.3) = 27.23 \longrightarrow h_{4s} = 702.07 \text{ kJ/kg} \text{ and } T_{4s} = 689.6 \text{ K}$$

$$\begin{aligned} \eta_T &= \frac{h_3 - h_4}{h_3 - h_{4s}} \longrightarrow h_4 = h_3 - \eta_T(h_3 - h_{4s}) \\ &= 1324.93 - (0.87)(1324.93 - 702.07) \\ &= 783.04 \text{ kJ/kg} \end{aligned}$$

Thus,

$$T_4 = \mathbf{764.4 \text{ K}}$$

$$(b) \quad q_{in} = h_3 - h_2 = 1324.93 - 626.60 = 698.3 \text{ kJ/kg}$$

$$q_{out} = h_4 - h_1 = 783.04 - 295.17 = 487.9 \text{ kJ/kg}$$

$$w_{net,out} = q_{in} - q_{out} = 698.3 - 487.9 = \mathbf{210.4 \text{ kJ/kg}}$$

$$(c) \quad \eta_{th} = \frac{w_{net,out}}{q_{in}} = \frac{210.4 \text{ kJ/kg}}{698.3 \text{ kJ/kg}} = 0.3013 = \mathbf{30.1\%}$$

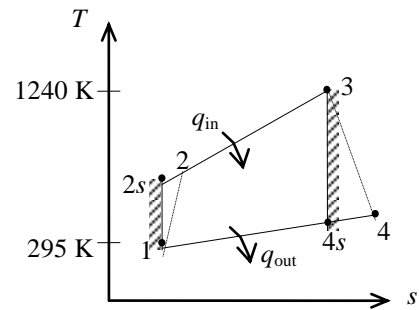



9-84 Problem 9-83 is reconsidered. The mass flow rate, pressure ratio, turbine inlet temperature, and the isentropic efficiencies of the turbine and compressor are to be varied and a general solution for the problem by taking advantage of the diagram window method for supplying data to EES is to be developed.

Analysis Using EES, the problem is solved as follows:

"Input data - from diagram window"

```
{P_ratio = 10}
{T[1] = 295 [K]
P[1]= 100 [kPa]
T[3] = 1240 [K]
m_dot = 20 [kg/s]
Eta_c = 83/100
Eta_t = 87/100}
```

"Inlet conditions"

```
h[1]=ENTHALPY(Air,T=T[1])
s[1]=ENTROPY(Air,T=T[1],P=P[1])
```

"Compressor analysis"

```
s_s[2]=s[1] "For the ideal case the entropies are constant across the compressor"
P_ratio=P[2]/P[1]"Definition of pressure ratio - to find P[2]"
T_s[2]=TEMPERATURE(Air,s=s_s[2],P=P[2]) "T_s[2] is the isentropic value of T[2] at compressor exit"
h_s[2]=ENTHALPY(Air,T=T_s[2])
Eta_c =(h_s[2]-h[1])/(h[2]-h[1]) "Compressor adiabatic efficiency; Eta_c = W_dot_c_ideal/W_dot_c_actual."
m_dot*h[1] +W_dot_c=m_dot*h[2] "SSSF First Law for the actual compressor, assuming: adiabatic, ke=pe=0"
"External heat exchanger analysis"
P[3]=P[2]"process 2-3 is SSSF constant pressure"
h[3]=ENTHALPY(Air,T=T[3])
m_dot*h[2] + Q_dot_in= m_dot*h[3]"SSSF First Law for the heat exchanger, assuming W=0, ke=pe=0"
```

"Turbine analysis"

```
s[3]=ENTROPY(Air,T=T[3],P=P[3])
s_s[4]=s[3] "For the ideal case the entropies are constant across the turbine"
P_ratio= P[3] /P[4]
T_s[4]=TEMPERATURE(Air,s=s_s[4],P=P[4]) "Ts[4] is the isentropic value of T[4] at turbine exit"
h_s[4]=ENTHALPY(Air,T=T_s[4]) "Eta_t = W_dot_t /Wts_dot turbine adiabatic efficiency, Wts_dot > W_dot_t"
Eta_t=(h[3]-h[4])/(h[3]-h_s[4])
m_dot*h[3] = W_dot_t + m_dot*h[4] "SSSF First Law for the actual compressor, assuming: adiabatic, ke=pe=0"
```

"Cycle analysis"

```
W_dot_net=W_dot_t-W_dot_c"Definition of the net cycle work, kW"
Eta=W_dot_net/Q_dot_in"Cycle thermal efficiency"
Bwr=W_dot_c/W_dot_t "Back work ratio"
```

"The following state points are determined only to produce a T-s plot"

```
T[2]=temperature(air,h=h[2])
T[4]=temperature(air,h=h[4])
s[2]=entropy(air,T=T[2],P=P[2])
s[4]=entropy(air,T=T[4],P=P[4])
```

Bwr	η	P_{ratio}	W_c [kW]	W_{net} [kW]	W_t [kW]	Q_{in} [kW]
0.5229	0.1	2	1818	1659	3477	16587
0.6305	0.1644	4	4033	2364	6396	14373
0.7038	0.1814	6	5543	2333	7876	12862
0.7611	0.1806	8	6723	2110	8833	11682
0.8088	0.1702	10	7705	1822	9527	10700
0.85	0.1533	12	8553	1510	10063	9852
0.8864	0.131	14	9304	1192	10496	9102
0.9192	0.1041	16	9980	877.2	10857	8426
0.9491	0.07272	18	10596	567.9	11164	7809
0.9767	0.03675	20	11165	266.1	11431	7241

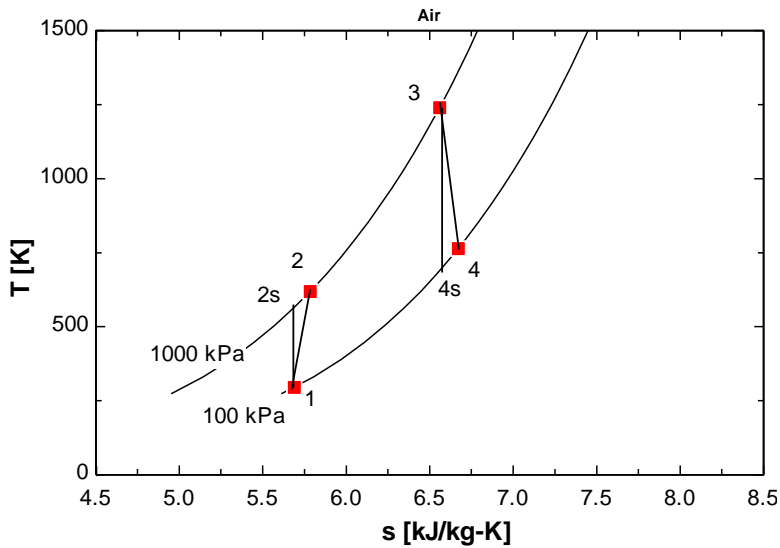
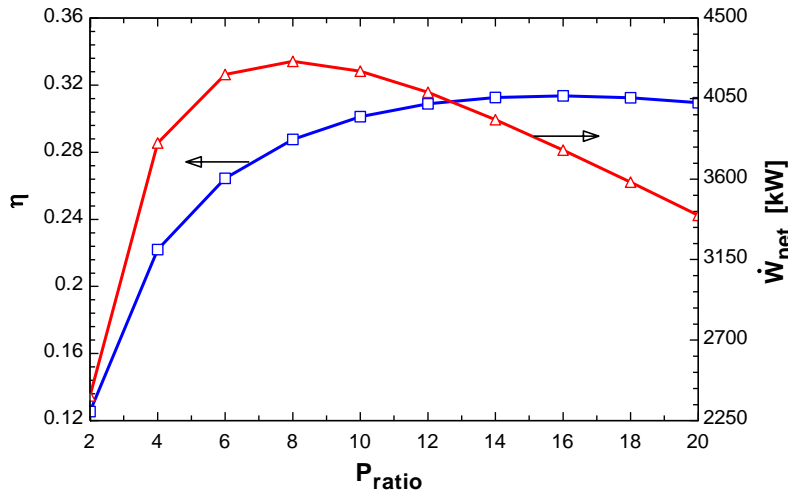

9-85 A simple Brayton cycle with air as the working fluid has a pressure ratio of 10. The air temperature at the turbine exit, the net work output, and the thermal efficiency are to be determined.

Assumptions 1 Steady operating conditions exist. 2 The air-standard assumptions are applicable. 3 Kinetic and potential energy changes are negligible. 4 Air is an ideal gas with constant specific heats.

Properties The properties of air at room temperature are $c_p = 1.005 \text{ kJ/kg}\cdot\text{K}$ and $k = 1.4$ (Table A-2).

Analysis (a) Using the compressor and turbine efficiency relations,

$$T_{2s} = T_1 \left(\frac{P_2}{P_1} \right)^{(k-1)/k} = (295 \text{ K})(10)^{0.4/1.4} = 569.6 \text{ K}$$

$$T_{4s} = T_3 \left(\frac{P_4}{P_3} \right)^{(k-1)/k} = (1240 \text{ K}) \left(\frac{1}{10} \right)^{0.4/1.4} = 642.3 \text{ K}$$

$$\eta_C = \frac{h_{2s} - h_1}{h_2 - h_1} = \frac{c_p(T_{2s} - T_1)}{c_p(T_2 - T_1)} \longrightarrow T_2 = T_1 + \frac{T_{2s} - T_1}{\eta_C}$$

$$= 295 + \frac{569.6 - 295}{0.83} = 625.8 \text{ K}$$

$$\eta_T = \frac{h_3 - h_4}{h_3 - h_{4s}} = \frac{c_p(T_3 - T_4)}{c_p(T_3 - T_{4s})} \longrightarrow T_4 = T_3 - \eta_T(T_3 - T_{4s})$$

$$= 1240 - (0.87)(1240 - 642.3)$$

$$= \mathbf{720 \text{ K}}$$

$$(b) \quad q_{in} = h_3 - h_2 = c_p(T_3 - T_2) = (1.005 \text{ kJ/kg}\cdot\text{K})(1240 - 625.8)\text{K} = 617.3 \text{ kJ/kg}$$

$$q_{out} = h_4 - h_1 = c_p(T_4 - T_1) = (1.005 \text{ kJ/kg}\cdot\text{K})(720 - 295)\text{K} = 427.1 \text{ kJ/kg}$$

$$w_{net,out} = q_{in} - q_{out} = 617.3 - 427.1 = \mathbf{190.2 \text{ kJ/kg}}$$

$$(c) \quad \eta_{th} = \frac{w_{net,out}}{q_{in}} = \frac{190.2 \text{ kJ/kg}}{617.3 \text{ kJ/kg}} = 0.3081 = \mathbf{30.8\%}$$

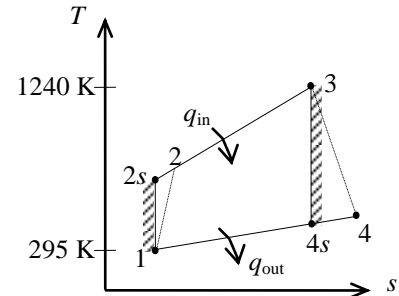

9-86 A simple Brayton cycle with air as the working fluid operates between the specified temperature and pressure limits. The effects of non-isentropic compressor and turbine on the back-work ratio is to be compared.

Assumptions 1 Steady operating conditions exist. 2 The air-standard assumptions are applicable. 3 Kinetic and potential energy changes are negligible. 4 Air is an ideal gas with constant specific heats.

Properties The properties of air at room temperature are $c_p = 1.005 \text{ kJ/kg}\cdot\text{K}$ and $k = 1.4$ (Table A-2a).

Analysis For the compression process,

$$T_{2s} = T_1 \left(\frac{P_2}{P_1} \right)^{(k-1)/k} = (288 \text{ K})(12)^{0.4/1.4} = 585.8 \text{ K}$$

$$\eta_C = \frac{h_{2s} - h_1}{h_2 - h_1} = \frac{c_p(T_{2s} - T_1)}{c_p(T_2 - T_1)} \longrightarrow T_2 = T_1 + \frac{T_{2s} - T_1}{\eta_C}$$

$$= 288 + \frac{585.8 - 288}{0.80}$$

$$= 660.2 \text{ K}$$

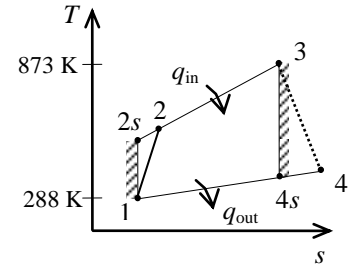

For the expansion process,

$$T_{4s} = T_3 \left(\frac{P_4}{P_3} \right)^{(k-1)/k} = (873 \text{ K}) \left(\frac{1}{12} \right)^{0.4/1.4} = 429.2 \text{ K}$$

$$\eta_T = \frac{h_3 - h_{4s}}{h_3 - h_4} = \frac{c_p(T_3 - T_{4s})}{c_p(T_3 - T_4)} \longrightarrow T_4 = T_3 - \eta_T(T_3 - T_{4s})$$

$$= 873 - (0.80)(873 - 429.2)$$

$$= 518.0 \text{ K}$$

The isentropic and actual work of compressor and turbine are

$$W_{\text{Comp},s} = c_p(T_{2s} - T_1) = (1.005 \text{ kJ/kg}\cdot\text{K})(585.8 - 288) \text{ K} = 299.3 \text{ kJ/kg}$$

$$W_{\text{Comp}} = c_p(T_2 - T_1) = (1.005 \text{ kJ/kg}\cdot\text{K})(660.2 - 288) \text{ K} = 374.1 \text{ kJ/kg}$$

$$W_{\text{Turb},s} = c_p(T_3 - T_{4s}) = (1.005 \text{ kJ/kg}\cdot\text{K})(873 - 429.2) \text{ K} = 446.0 \text{ kJ/kg}$$

$$W_{\text{Turb}} = c_p(T_3 - T_4) = (1.005 \text{ kJ/kg}\cdot\text{K})(873 - 518.0) \text{ K} = 356.8 \text{ kJ/kg}$$

The back work ratio for 90% efficient compressor and isentropic turbine case is

$$r_{\text{bw}} = \frac{W_{\text{Comp}}}{W_{\text{Turb},s}} = \frac{374.1 \text{ kJ/kg}}{446.0 \text{ kJ/kg}} = \mathbf{0.8387}$$

The back work ratio for 90% efficient turbine and isentropic compressor case is

$$r_{\text{bw}} = \frac{W_{\text{Comp},s}}{W_{\text{Turb}}} = \frac{299.3 \text{ kJ/kg}}{356.8 \text{ kJ/kg}} = \mathbf{0.8387}$$

The two results are identical.

9-87 A gas turbine power plant that operates on the simple Brayton cycle with air as the working fluid has a specified pressure ratio. The required mass flow rate of air is to be determined for two cases.

Assumptions **1** Steady operating conditions exist. **2** The air-standard assumptions are applicable. **3** Kinetic and potential energy changes are negligible. **4** Air is an ideal gas with constant specific heats.

Properties The properties of air at room temperature are $c_p = 1.005 \text{ kJ/kg}\cdot\text{K}$ and $k = 1.4$ (Table A-2).

Analysis (a) Using the isentropic relations,

$$T_{2s} = T_1 \left(\frac{P_2}{P_1} \right)^{(k-1)/k} = (300 \text{ K})(12)^{0.4/1.4} = 610.2 \text{ K}$$

$$T_{4s} = T_3 \left(\frac{P_4}{P_3} \right)^{(k-1)/k} = (1000 \text{ K}) \left(\frac{1}{12} \right)^{0.4/1.4} = 491.7 \text{ K}$$

$$w_{s,C,in} = h_{2s} - h_1 = c_p (T_{2s} - T_1) = (1.005 \text{ kJ/kg}\cdot\text{K})(610.2 - 300) \text{ K} = 311.75 \text{ kJ/kg}$$

$$w_{s,T,out} = h_3 - h_{4s} = c_p (T_3 - T_{4s}) = (1.005 \text{ kJ/kg}\cdot\text{K})(1000 - 491.7) \text{ K} = 510.84 \text{ kJ/kg}$$

$$w_{s,net,out} = w_{s,T,out} - w_{s,C,in} = 510.84 - 311.75 = 199.1 \text{ kJ/kg}$$

$$\dot{m}_s = \frac{\dot{W}_{net,out}}{w_{s,net,out}} = \frac{70,000 \text{ kJ/s}}{199.1 \text{ kJ/kg}} = \mathbf{352 \text{ kg/s}}$$

(b) The net work output is determined to be

$$w_{a,net,out} = w_{a,T,out} - w_{a,C,in} = \eta_T w_{s,T,out} - w_{s,C,in} / \eta_C$$

$$= (0.85)(510.84) - 311.75 / 0.85 = 67.5 \text{ kJ/kg}$$

$$\dot{m}_a = \frac{\dot{W}_{net,out}}{w_{a,net,out}} = \frac{70,000 \text{ kJ/s}}{67.5 \text{ kJ/kg}} = \mathbf{1037 \text{ kg/s}}$$

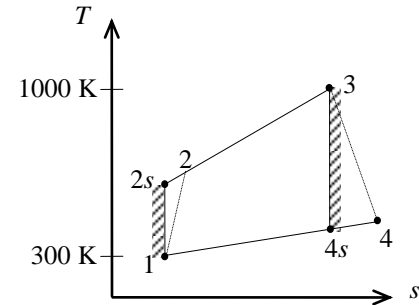

9-88 An aircraft engine operates as a simple ideal Brayton cycle with air as the working fluid. The pressure ratio and the rate of heat input are given. The net power and the thermal efficiency are to be determined.

Assumptions 1 Steady operating conditions exist. 2 The air-standard assumptions are applicable. 3 Kinetic and potential energy changes are negligible. 4 Air is an ideal gas with constant specific heats.

Properties The properties of air at room temperature are $c_p = 1.005 \text{ kJ/kg}\cdot\text{K}$ and $k = 1.4$ (Table A-2a).

Analysis For the isentropic compression process,

$$T_2 = T_1 r_p^{(k-1)/k} = (273 \text{ K})(10)^{0.4/1.4} = 527.1 \text{ K}$$

The heat addition is

$$q_{\text{in}} = \frac{\dot{Q}_{\text{in}}}{\dot{m}} = \frac{500 \text{ kW}}{1 \text{ kg/s}} = 500 \text{ kJ/kg}$$

Applying the first law to the heat addition process,

$$q_{\text{in}} = c_p(T_3 - T_2)$$

$$T_3 = T_2 + \frac{q_{\text{in}}}{c_p} = 527.1 \text{ K} + \frac{500 \text{ kJ/kg}}{1.005 \text{ kJ/kg}\cdot\text{K}} = 1025 \text{ K}$$

The temperature at the exit of the turbine is

$$T_4 = T_3 \left(\frac{1}{r_p} \right)^{(k-1)/k} = (1025 \text{ K}) \left(\frac{1}{10} \right)^{0.4/1.4} = 530.9 \text{ K}$$

Applying the first law to the adiabatic turbine and the compressor produce

$$w_T = c_p(T_3 - T_4) = (1.005 \text{ kJ/kg}\cdot\text{K})(1025 - 530.9) \text{ K} = 496.6 \text{ kJ/kg}$$

$$w_C = c_p(T_2 - T_1) = (1.005 \text{ kJ/kg}\cdot\text{K})(527.1 - 273) \text{ K} = 255.4 \text{ kJ/kg}$$

The net power produced by the engine is then

$$\dot{W}_{\text{net}} = \dot{m}(w_T - w_C) = (1 \text{ kg/s})(496.6 - 255.4) \text{ kJ/kg} = \mathbf{241.2 \text{ kW}}$$

Finally the thermal efficiency is

$$\eta_{\text{th}} = \frac{\dot{W}_{\text{net}}}{\dot{Q}_{\text{in}}} = \frac{241.2 \text{ kW}}{500 \text{ kW}} = \mathbf{0.482}$$

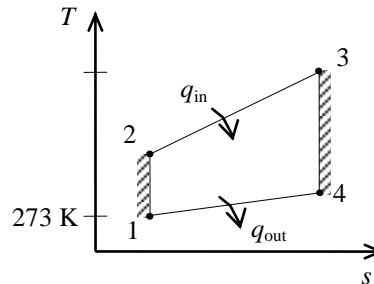

9-89 An aircraft engine operates as a simple ideal Brayton cycle with air as the working fluid. The pressure ratio and the rate of heat input are given. The net power and the thermal efficiency are to be determined.

Assumptions 1 Steady operating conditions exist. 2 The air-standard assumptions are applicable. 3 Kinetic and potential energy changes are negligible. 4 Air is an ideal gas with constant specific heats.

Properties The properties of air at room temperature are $c_p = 1.005 \text{ kJ/kg}\cdot\text{K}$ and $k = 1.4$ (Table A-2a).

Analysis For the isentropic compression process,

$$T_2 = T_1 r_p^{(k-1)/k} = (273 \text{ K})(15)^{0.4/1.4} = 591.8 \text{ K}$$

The heat addition is

$$q_{\text{in}} = \frac{\dot{Q}_{\text{in}}}{\dot{m}} = \frac{500 \text{ kW}}{1 \text{ kg/s}} = 500 \text{ kJ/kg}$$

Applying the first law to the heat addition process,

$$q_{\text{in}} = c_p (T_3 - T_2)$$

$$T_3 = T_2 + \frac{q_{\text{in}}}{c_p} = 591.8 \text{ K} + \frac{500 \text{ kJ/kg}}{1.005 \text{ kJ/kg}\cdot\text{K}} = 1089 \text{ K}$$

The temperature at the exit of the turbine is

$$T_4 = T_3 \left(\frac{1}{r_p} \right)^{(k-1)/k} = (1089 \text{ K}) \left(\frac{1}{15} \right)^{0.4/1.4} = 502.3 \text{ K}$$

Applying the first law to the adiabatic turbine and the compressor produce

$$w_T = c_p (T_3 - T_4) = (1.005 \text{ kJ/kg}\cdot\text{K})(1089 - 502.3) \text{ K} = 589.6 \text{ kJ/kg}$$

$$w_C = c_p (T_2 - T_1) = (1.005 \text{ kJ/kg}\cdot\text{K})(591.8 - 273) \text{ K} = 320.4 \text{ kJ/kg}$$

The net power produced by the engine is then

$$\dot{W}_{\text{net}} = \dot{m}(w_T - w_C) = (1 \text{ kg/s})(589.6 - 320.4) \text{ kJ/kg} = \mathbf{269.2 \text{ kW}}$$

Finally the thermal efficiency is

$$\eta_{\text{th}} = \frac{\dot{W}_{\text{net}}}{\dot{Q}_{\text{in}}} = \frac{269.2 \text{ kW}}{500 \text{ kW}} = \mathbf{0.538}$$

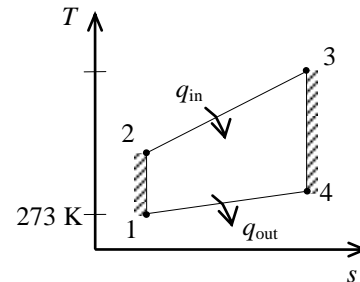

9-90 A gas-turbine plant operates on the simple Brayton cycle. The net power output, the back work ratio, and the thermal efficiency are to be determined.

Assumptions 1 The air-standard assumptions are applicable. **2** Kinetic and potential energy changes are negligible. **3** Air is an ideal gas with variable specific heats.

Properties The gas constant of air is $R = 0.287 \text{ kJ/kg}\cdot\text{K}$ (Table A-1).

Analysis (a) For this problem, we use the properties from EES software.

Remember that for an ideal gas, enthalpy is a function of temperature only whereas entropy is functions of both temperature and pressure.

Process 1-2: Compression

$$\begin{aligned} T_1 &= 40^\circ\text{C} \longrightarrow h_1 = 313.6 \text{ kJ/kg} \\ \left. \begin{aligned} T_1 &= 40^\circ\text{C} \\ P_1 &= 100 \text{ kPa} \end{aligned} \right\} s_1 &= 5.749 \text{ kJ/kg}\cdot\text{K} \\ \left. \begin{aligned} P_2 &= 1600 \text{ kPa} \\ s_2 &= s_1 = 5.749 \text{ kJ/kg}\cdot\text{K} \end{aligned} \right\} h_{2s} &= 691.9 \text{ kJ/kg} \\ \eta_C &= \frac{h_{2s} - h_1}{h_2 - h_1} \longrightarrow 0.85 = \frac{691.9 - 313.6}{h_2 - 313.6} \longrightarrow h_2 = 758.6 \text{ kJ/kg} \end{aligned}$$

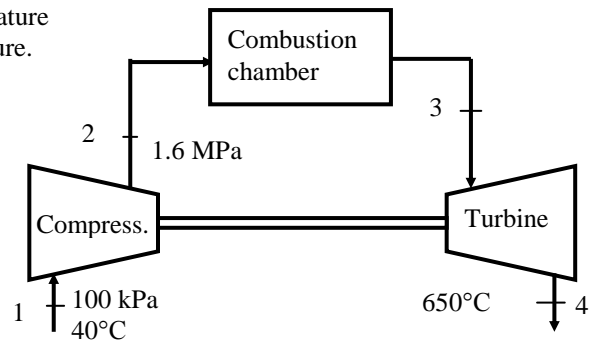

Process 3-4: Expansion

$$\begin{aligned} T_4 &= 650^\circ\text{C} \longrightarrow h_4 = 959.2 \text{ kJ/kg} \\ \eta_T &= \frac{h_3 - h_4}{h_3 - h_{4s}} \longrightarrow 0.88 = \frac{h_3 - 959.2}{h_3 - h_{4s}} \end{aligned}$$

We cannot find the enthalpy at state 3 directly. However, using the EES program, we find

$$h_3 = 1790 \text{ kJ/kg}, \quad T_3 = 1353^\circ\text{C}, \quad s_3 = 6.750 \text{ kJ/kg}\cdot\text{K}.$$

The solution by hand would require a trial-error approach. The mass flow rate is determined from

$$\dot{m} = \frac{P_1 \dot{V}_1}{RT_1} = \frac{(100 \text{ kPa})(850/60 \text{ m}^3/\text{s})}{(0.287 \text{ kPa}\cdot\text{m}^3/\text{kg}\cdot\text{K})(40 + 273 \text{ K})} = 15.77 \text{ kg/s}$$

The net power output is

$$\begin{aligned} \dot{W}_{C,\text{in}} &= \dot{m}(h_2 - h_1) = (15.77 \text{ kg/s})(758.6 - 313.6) \text{ kJ/kg} = 7017 \text{ kW} \\ \dot{W}_{T,\text{out}} &= \dot{m}(h_3 - h_4) = (15.77 \text{ kg/s})(1790 - 959.2) \text{ kJ/kg} = 13,098 \text{ kW} \\ \dot{W}_{\text{net}} &= \dot{W}_{T,\text{out}} - \dot{W}_{C,\text{in}} = 13,098 - 7017 = \mathbf{6081 \text{ kW}} \end{aligned}$$

(b) The back work ratio is

$$r_{\text{bw}} = \frac{\dot{W}_{C,\text{in}}}{\dot{W}_{T,\text{out}}} = \frac{7017 \text{ kW}}{13,098 \text{ kW}} = \mathbf{0.536}$$

(c) The rate of heat input and the thermal efficiency are

$$\begin{aligned} \dot{Q}_{\text{in}} &= \dot{m}(h_3 - h_2) = (15.77 \text{ kg/s})(1790 - 758.6) \text{ kJ/kg} = 16,262 \text{ kW} \\ \eta_{\text{th}} &= \frac{\dot{W}_{\text{net}}}{\dot{Q}_{\text{in}}} = \frac{6081 \text{ kW}}{16,262 \text{ kW}} = 0.374 = \mathbf{37.4\%} \end{aligned}$$

The complete EES code for the solution of this problem is given next:

"GIVEN"

$P_1=100$ [kPa]
 $P_2=1600$ [kPa]
 $T_1=40$ [C]
 $\text{Vol_dot}_1=850[\text{m}^3/\text{min}]*\text{Convert}(\text{m}^3/\text{min}, \text{m}^3/\text{s})$
 $T_4=650$ [C]
 $\text{eta}_C=0.85$
 $\text{eta}_T=0.88$

"PROPERTIES"

$\text{Fluid}='Air'$
 $R=R_u/\text{MM}$
 $R_u=8.314$ [kJ/kmol-K]
 $\text{MM}=\text{Molarmass}(\text{Fluid})$
 $h_1=\text{enthalpy}(\text{Fluid}, T=T_1)$
 $s_1=\text{entropy}(\text{Fluid}, T=T_1, P=P_1)$
 $h_{2s}=\text{enthalpy}(\text{Fluid}, P=P_2, s=s_1)$
 $h_2=h_1+(h_{2s}-h_1)/\text{eta}_C$
 $h_4=\text{enthalpy}(\text{Fluid}, T=T_4)$
 $s_3=\text{entropy}(\text{Fluid}, T=T_3, P=P_2)$
 $h_3=\text{enthalpy}(\text{Fluid}, T=T_3)$
 $h_{4s}=\text{enthalpy}(\text{Fluid}, P=P_1, s=s_3)$
 $h_3=h_4+\text{eta}_T*(h_3-h_{4s})$

"ANALYSIS"

$m_{\text{dot}}=(P_1*\text{Vol_dot}_1)/(R*(T_1+273))$
 $W_{\text{dot}_C\text{in}}=m_{\text{dot}}*(h_2-h_1)$
 $W_{\text{dot}_T\text{out}}=m_{\text{dot}}*(h_3-h_4)$
 $W_{\text{dot}_\text{net}}=W_{\text{dot}_T\text{out}}-W_{\text{dot}_C\text{in}}$
 $r_{\text{bw}}=W_{\text{dot}_C\text{in}}/W_{\text{dot}_T\text{out}}$
 $Q_{\text{dot}_\text{in}}=m_{\text{dot}}*(h_3-h_2)$
 $\text{eta}_{\text{th}}=W_{\text{dot}_\text{net}}/Q_{\text{dot}_\text{in}}$

9-91E A gas-turbine power plant operates on a simple Brayton cycle with air as the working fluid. The net power output of the plant is to be determined.

Assumptions 1 Steady operating conditions exist. 2 The air-standard assumptions are applicable. 3 Kinetic and potential energy changes are negligible. 4 Air is an ideal gas with variable specific heats.

Properties The properties of air are given in Table A-17E.

Analysis Using variable specific heats for air,

$$T_3 = 2000 \text{ R} \longrightarrow h_3 = 504.71 \text{ Btu/lbm}$$

$$T_4 = 1200 \text{ R} \longrightarrow h_4 = 291.30 \text{ Btu/lbm}$$

$$r_p = \frac{P_2}{P_1} = \frac{120}{15} = 8$$

$$\dot{Q}_{\text{out}} = \dot{m}(h_4 - h_1) \longrightarrow h_1 = 291.30 - 6400/40 = 131.30 \text{ Btu/lbm}$$

$$\longrightarrow P_{r_1} = 1.474$$

$$P_{r_2} = \frac{P_2}{P_1} P_{r_1} = (8)(1.474) = 11.79 \longrightarrow h_{2s} = 238.07 \text{ Btu/lbm}$$

$$\dot{W}_{C,\text{in}} = \dot{m}(h_{2s} - h_1) / \eta_C = (40 \text{ lbm/s})(238.07 - 131.30) / (0.80) = 5339 \text{ Btu/s}$$

$$\dot{W}_{T,\text{out}} = \dot{m}(h_3 - h_4) = (40 \text{ lbm/s})(504.71 - 291.30) \text{ Btu/lbm} = 8536 \text{ Btu/s}$$

$$\dot{W}_{\text{net,out}} = \dot{W}_{T,\text{out}} - \dot{W}_{C,\text{in}} = 8536 - 5339 = 3197 \text{ Btu/s} = \mathbf{3373 \text{ kW}}$$

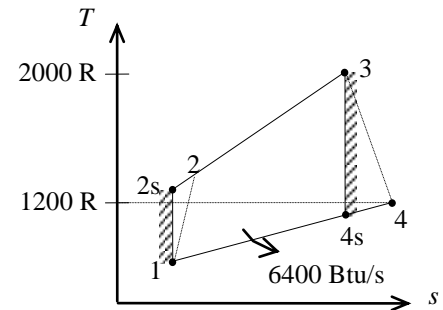

9-92E A gas-turbine power plant operates on a simple Brayton cycle with air as the working fluid. The compressor efficiency for which the power plant produces zero net work is to be determined.

Assumptions 1 Steady operating conditions exist. 2 The air-standard assumptions are applicable. 3 Kinetic and potential energy changes are negligible. 4 Air is an ideal gas with variable specific heats.

Properties The properties of air are given in Table A-17E.

Analysis Using variable specific heats,

$$T_3 = 2000 \text{ R} \longrightarrow h_3 = 504.71 \text{ Btu/lbm}$$

$$T_4 = 1200 \text{ R} \longrightarrow h_4 = 291.30 \text{ Btu/lbm}$$

$$r_p = \frac{P_2}{P_1} = \frac{120}{15} = 8$$

$$\dot{Q}_{\text{out}} = \dot{m}(h_4 - h_1) \longrightarrow h_1 = 291.30 - 6400/40 = 131.30 \text{ Btu/lbm} \longrightarrow P_{r_1} = 1.474$$

$$P_{r_2} = \frac{P_2}{P_1} P_{r_1} = (8)(1.474) = 11.79 \longrightarrow h_{2s} = 238.07 \text{ Btu/lbm}$$

Then, $\dot{W}_{C,\text{in}} = \dot{W}_{T,\text{out}} \longrightarrow \dot{m}(h_{2s} - h_1) / \eta_C = \dot{m}(h_3 - h_4)$

$$\eta_C = \frac{h_{2s} - h_1}{h_3 - h_4} = \frac{238.07 - 131.30}{504.71 - 291.30} = \mathbf{50.0\%}$$

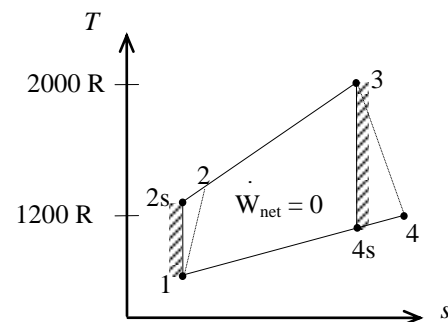

9-93 A simple Brayton cycle with air as the working fluid operates between the specified temperature and pressure limits. The cycle is to be sketched on the T - s cycle and the isentropic efficiency of the turbine and the cycle thermal efficiency are to be determined.

Assumptions 1 Steady operating conditions exist. 2 The air-standard assumptions are applicable. 3 Kinetic and potential energy changes are negligible. 4 Air is an ideal gas with constant specific heats.

Properties The properties of air are given as $c_v = 0.718$ kJ/kg·K, $c_p = 1.005$ kJ/kg·K, $R = 0.287$ kJ/kg·K, $k = 1.4$.

Analysis (b) For the compression process,

$$\begin{aligned}\dot{W}_{\text{Comp}} &= \dot{m}c_p(T_2 - T_1) \\ &= (200 \text{ kg/s})(1.005 \text{ kJ/kg} \cdot \text{K})(330 - 30)\text{K} \\ &= 60,300 \text{ kW}\end{aligned}$$

For the turbine during the isentropic process,

$$T_{4s} = T_3 \left(\frac{P_4}{P_3} \right)^{(k-1)/k} = (1400 \text{ K}) \left(\frac{100 \text{ kPa}}{800 \text{ kPa}} \right)^{0.4/1.4} = 772.9 \text{ K}$$

$$\dot{W}_{\text{Turb},s} = \dot{m}c_p(T_3 - T_{4s}) = (200 \text{ kg/s})(1.005 \text{ kJ/kg} \cdot \text{K})(1400 - 772.9)\text{K} = 126,050 \text{ kW}$$

The actual power output from the turbine is

$$\begin{aligned}\dot{W}_{\text{net}} &= \dot{W}_{\text{Turb}} - \dot{W}_{\text{Comp}} \\ \dot{W}_{\text{Turb}} &= \dot{W}_{\text{net}} + \dot{W}_{\text{Comp}} = 60,000 + 60,300 = 120,300 \text{ kW}\end{aligned}$$

The isentropic efficiency of the turbine is then

$$\eta_{\text{Turb}} = \frac{\dot{W}_{\text{Turb}}}{\dot{W}_{\text{Turb},s}} = \frac{120,300 \text{ kW}}{126,050 \text{ kW}} = 0.954 = \mathbf{95.4\%}$$

(c) The rate of heat input is

$$\dot{Q}_{\text{in}} = \dot{m}c_p(T_3 - T_2) = (200 \text{ kg/s})(1.005 \text{ kJ/kg} \cdot \text{K})[(1400 - (330 + 273))\text{K}] = 160,200 \text{ kW}$$

The thermal efficiency is then

$$\eta_{\text{th}} = \frac{\dot{W}_{\text{net}}}{\dot{Q}_{\text{in}}} = \frac{60,000 \text{ kW}}{160,200 \text{ kW}} = 0.375 = \mathbf{37.5\%}$$

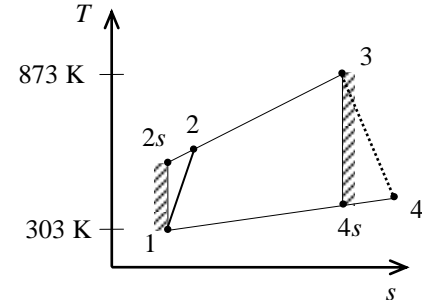

9-94 A modified Brayton cycle with air as the working fluid operates at a specified pressure ratio. The T - s diagram is to be sketched and the temperature and pressure at the exit of the high-pressure turbine and the mass flow rate of air are to be determined.

Assumptions 1 Steady operating conditions exist. 2 The air-standard assumptions are applicable. 3 Kinetic and potential energy changes are negligible. 4 Air is an ideal gas with constant specific heats.

Properties The properties of air are given as $c_v = 0.718$ kJ/kg·K, $c_p = 1.005$ kJ/kg·K, $R = 0.287$ kJ/kg·K, $k = 1.4$.

Analysis (b) For the compression process,

$$T_2 = T_1 \left(\frac{P_2}{P_1} \right)^{(k-1)/k} = (273 \text{ K})(8)^{0.4/1.4} = 494.5 \text{ K}$$

The power input to the compressor is equal to the power output from the high-pressure turbine. Then,

$$\begin{aligned} \dot{W}_{\text{Comp, in}} &= \dot{W}_{\text{HP Turb, out}} \\ \dot{m} c_p (T_2 - T_1) &= \dot{m} c_p (T_3 - T_4) \\ T_2 - T_1 &= T_3 - T_4 \\ T_4 &= T_3 + T_1 - T_2 = 1500 + 273 - 494.5 = \mathbf{1278.5 \text{ K}} \end{aligned}$$

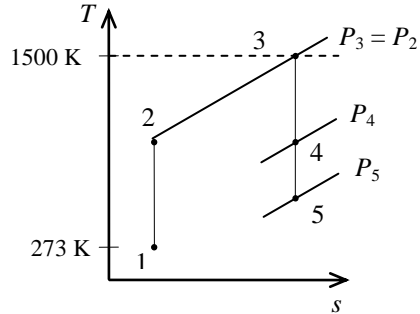

The pressure at this state is

$$\frac{P_4}{P_3} = \left(\frac{T_4}{T_3} \right)^{k/(k-1)} \longrightarrow P_4 = r P_1 \left(\frac{T_4}{T_3} \right)^{k/(k-1)} = 8(100 \text{ kPa}) \left(\frac{1278.5 \text{ K}}{1500 \text{ K}} \right)^{1.4/0.4} = \mathbf{457.3 \text{ kPa}}$$

(c) The temperature at state 5 is determined from

$$T_5 = T_4 \left(\frac{P_5}{P_4} \right)^{(k-1)/k} = (1278.5 \text{ K}) \left(\frac{100 \text{ kPa}}{457.3 \text{ kPa}} \right)^{0.4/1.4} = 828.1 \text{ K}$$

The net power is that generated by the low-pressure turbine since the power output from the high-pressure turbine is equal to the power input to the compressor. Then,

$$\begin{aligned} \dot{W}_{\text{LP Turb}} &= \dot{m} c_p (T_4 - T_5) \\ \dot{m} &= \frac{\dot{W}_{\text{LP Turb}}}{c_p (T_4 - T_5)} = \frac{200,000 \text{ kW}}{(1.005 \text{ kJ/kg} \cdot \text{K})(1278.5 - 828.1) \text{ K}} \\ &= \mathbf{441.8 \text{ kg/s}} \end{aligned}$$

Brayton Cycle with Regeneration

9-95C Regeneration increases the thermal efficiency of a Brayton cycle by capturing some of the waste heat from the exhaust gases and preheating the air before it enters the combustion chamber.

9-96C Yes. At very high compression ratios, the gas temperature at the turbine exit may be lower than the temperature at the compressor exit. Therefore, if these two streams are brought into thermal contact in a regenerator, heat will flow to the exhaust gases instead of from the exhaust gases. As a result, the thermal efficiency will decrease.

9-97C (b) turbine exit.

9-98C The steam injected increases the mass flow rate through the turbine and thus the power output. This, in turn, increases the thermal efficiency since $\eta = W / Q_{\text{in}}$ and W increases while Q_{in} remains constant. Steam can be obtained by utilizing the hot exhaust gases.

9-99 A Brayton cycle with regeneration produces 115 kW power. The rates of heat addition and rejection are to be determined.

Assumptions 1 The air standard assumptions are applicable. **2** Air is an ideal gas with constant specific heats at room temperature. **3** Kinetic and potential energy changes are negligible.

Properties The properties of air at room temperature are $c_p = 1.005 \text{ kJ/kg}\cdot\text{K}$ and $k = 1.4$ (Table A-2a).

Analysis According to the isentropic process expressions for an ideal gas,

$$T_2 = T_1 r_p^{(k-1)/k} = (303 \text{ K})(10)^{0.4/1.4} = 585.0 \text{ K}$$

$$T_5 = T_4 \left(\frac{1}{r_p} \right)^{(k-1)/k} = (1073 \text{ K}) \left(\frac{1}{10} \right)^{0.4/1.4} = 555.8 \text{ K}$$

When the first law is applied to the heat exchanger, the result is

$$T_3 - T_2 = T_5 - T_6$$

while the regenerator temperature specification gives

$$T_3 = T_5 - 10 = 555.8 - 10 = 545.8 \text{ K}$$

The simultaneous solution of these two results gives

$$T_6 = T_5 - (T_3 - T_2) = 555.8 - (545.8 - 585.0) = 595.0 \text{ K}$$

Application of the first law to the turbine and compressor gives

$$\begin{aligned} w_{\text{net}} &= c_p (T_4 - T_5) - c_p (T_2 - T_1) \\ &= (1.005 \text{ kJ/kg}\cdot\text{K})(1073 - 555.8) \text{ K} - (1.005 \text{ kJ/kg}\cdot\text{K})(585.0 - 303) \text{ K} \\ &= 236.4 \text{ kJ/kg} \end{aligned}$$

Then,

$$\dot{m} = \frac{\dot{W}_{\text{net}}}{w_{\text{net}}} = \frac{115 \text{ kW}}{236.4 \text{ kJ/kg}} = 0.4864 \text{ kg/s}$$

Applying the first law to the combustion chamber produces

$$\dot{Q}_{\text{in}} = \dot{m} c_p (T_4 - T_3) = (0.4864 \text{ kg/s})(1.005 \text{ kJ/kg}\cdot\text{K})(1073 - 545.8) \text{ K} = \mathbf{258 \text{ kW}}$$

Similarly,

$$\dot{Q}_{\text{out}} = \dot{m} c_p (T_6 - T_1) = (0.4864 \text{ kg/s})(1.005 \text{ kJ/kg}\cdot\text{K})(595.0 - 303) \text{ K} = \mathbf{143 \text{ kW}}$$

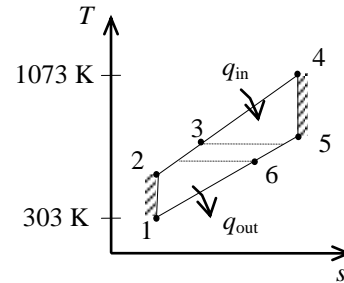

9-100 A Brayton cycle with regeneration produces 115 kW power. The rates of heat addition and rejection are to be determined.

Assumptions 1 The air standard assumptions are applicable. **2** Air is an ideal gas with constant specific heats at room temperature. **3** Kinetic and potential energy changes are negligible.

Properties The properties of air at room temperature are $c_p = 1.005 \text{ kJ/kg}\cdot\text{K}$ and $k = 1.4$ (Table A-2a).

Analysis For the compression and expansion processes we have

$$T_{2s} = T_1 r_p^{(k-1)/k} = (303 \text{ K})(10)^{0.4/1.4} = 585.0 \text{ K}$$

$$\eta_C = \frac{c_p(T_{2s} - T_1)}{c_p(T_2 - T_1)} \longrightarrow T_2 = T_1 + \frac{T_{2s} - T_1}{\eta_C}$$

$$= 303 + \frac{585.0 - 303}{0.87} = 627.1 \text{ K}$$

$$T_{5s} = T_4 \left(\frac{1}{r_p} \right)^{(k-1)/k} = (1073 \text{ K}) \left(\frac{1}{10} \right)^{0.4/1.4} = 555.8 \text{ K}$$

$$\eta_T = \frac{c_p(T_4 - T_5)}{c_p(T_4 - T_{5s})} \longrightarrow T_5 = T_4 - \eta_T(T_4 - T_{5s})$$

$$= 1073 - (0.93)(1073 - 555.8)$$

$$= 592.0 \text{ K}$$

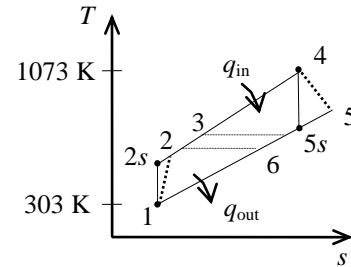

When the first law is applied to the heat exchanger, the result is

$$T_3 - T_2 = T_5 - T_6$$

while the regenerator temperature specification gives

$$T_3 = T_5 - 10 = 592.0 - 10 = 582.0 \text{ K}$$

The simultaneous solution of these two results gives

$$T_6 = T_5 - (T_3 - T_2) = 592.0 - (582.0 - 627.1) = 637.1 \text{ K}$$

Application of the first law to the turbine and compressor gives

$$w_{\text{net}} = c_p(T_4 - T_5) - c_p(T_2 - T_1)$$

$$= (1.005 \text{ kJ/kg}\cdot\text{K})(1073 - 592.0) \text{ K} - (1.005 \text{ kJ/kg}\cdot\text{K})(627.1 - 303) \text{ K}$$

$$= 157.7 \text{ kJ/kg}$$

Then,

$$\dot{m} = \frac{\dot{W}_{\text{net}}}{w_{\text{net}}} = \frac{115 \text{ kW}}{157.7 \text{ kJ/kg}} = 0.7293 \text{ kg/s}$$

Applying the first law to the combustion chamber produces

$$\dot{Q}_{\text{in}} = \dot{m} c_p(T_4 - T_3) = (0.7293 \text{ kg/s})(1.005 \text{ kJ/kg}\cdot\text{K})(1073 - 582.0) \text{ K} = \mathbf{360 \text{ kW}}$$

Similarly,

$$\dot{Q}_{\text{out}} = \dot{m} c_p(T_6 - T_1) = (0.7293 \text{ kg/s})(1.005 \text{ kJ/kg}\cdot\text{K})(637.1 - 303) \text{ K} = \mathbf{245 \text{ kW}}$$

9-101 A Brayton cycle with regeneration is considered. The thermal efficiencies of the cycle for parallel-flow and counter-flow arrangements of the regenerator are to be compared.

Assumptions 1 The air standard assumptions are applicable. **2** Air is an ideal gas with constant specific heats at room temperature. **3** Kinetic and potential energy changes are negligible.

Properties The properties of air at room temperature are $c_p = 1.005 \text{ kJ/kg}\cdot\text{K}$ and $k = 1.4$ (Table A-2a).

Analysis According to the isentropic process expressions for an ideal gas,

$$T_2 = T_1 r_p^{(k-1)/k} = (293 \text{ K})(7)^{0.4/1.4} = 510.9 \text{ K}$$

$$T_5 = T_4 \left(\frac{1}{r_p} \right)^{(k-1)/k} = (1000 \text{ K}) \left(\frac{1}{7} \right)^{0.4/1.4} = 573.5 \text{ K}$$

When the first law is applied to the heat exchanger as originally arranged, the result is

$$T_3 - T_2 = T_5 - T_6$$

while the regenerator temperature specification gives

$$T_3 = T_5 - 6 = 573.5 - 6 = 567.5 \text{ K}$$

The simultaneous solution of these two results gives

$$T_6 = T_5 - T_3 + T_2 = 573.5 - 567.5 + 510.9 = 516.9 \text{ K}$$

The thermal efficiency of the cycle is then

$$\eta_{\text{th}} = 1 - \frac{q_{\text{out}}}{q_{\text{in}}} = 1 - \frac{T_6 - T_1}{T_4 - T_3} = 1 - \frac{516.9 - 293}{1000 - 567.5} = \mathbf{0.482}$$

For the rearranged version of this cycle,

$$T_3 = T_6 - 6$$

An energy balance on the heat exchanger gives

$$T_3 - T_2 = T_5 - T_6$$

The solution of these two equations is

$$T_3 = 539.2 \text{ K}$$

$$T_6 = 545.2 \text{ K}$$

The thermal efficiency of the cycle is then

$$\eta_{\text{th}} = 1 - \frac{q_{\text{out}}}{q_{\text{in}}} = 1 - \frac{T_6 - T_1}{T_4 - T_3} = 1 - \frac{545.2 - 293}{1000 - 539.2} = \mathbf{0.453}$$

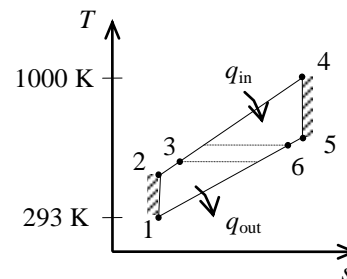
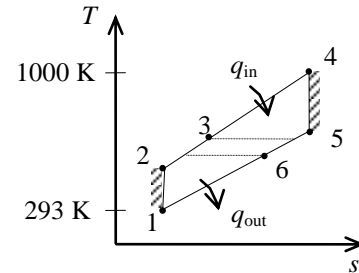

9-102E An ideal Brayton cycle with regeneration has a pressure ratio of 11. The thermal efficiency of the cycle is to be determined with and without regenerator cases.

Assumptions 1 The air standard assumptions are applicable. **2** Air is an ideal gas with constant specific heats at room temperature. **3** Kinetic and potential energy changes are negligible.

Properties The properties of air at room temperature are $c_p = 0.24$ Btu/lbm-R and $k = 1.4$ (Table A-2Ea).

Analysis According to the isentropic process expressions for an ideal gas,

$$T_2 = T_1 r_p^{(k-1)/k} = (560 \text{ R})(11)^{0.4/1.4} = 1111 \text{ R}$$

$$T_5 = T_4 \left(\frac{1}{r_p} \right)^{(k-1)/k} = (2400 \text{ R}) \left(\frac{1}{11} \right)^{0.4/1.4} = 1210 \text{ R}$$

The regenerator is ideal (i.e., the effectiveness is 100%) and thus,

$$T_3 = T_5 = 1210 \text{ R}$$

$$T_6 = T_2 = 1111 \text{ R}$$

The thermal efficiency of the cycle is then

$$\eta_{\text{th}} = 1 - \frac{q_{\text{out}}}{q_{\text{in}}} = 1 - \frac{T_6 - T_1}{T_4 - T_3} = 1 - \frac{1111 - 560}{2400 - 1210} = 0.537 = \mathbf{53.7\%}$$

The solution without a regenerator is as follows:

$$T_2 = T_1 r_p^{(k-1)/k} = (560 \text{ R})(11)^{0.4/1.4} = 1111 \text{ R}$$

$$T_4 = T_3 \left(\frac{1}{r_p} \right)^{(k-1)/k} = (2400 \text{ R}) \left(\frac{1}{11} \right)^{0.4/1.4} = 1210 \text{ R}$$

$$\eta_{\text{th}} = 1 - \frac{q_{\text{out}}}{q_{\text{in}}} = 1 - \frac{T_4 - T_1}{T_3 - T_2} = 1 - \frac{1210 - 560}{2400 - 1111} = 0.496 = \mathbf{49.6\%}$$

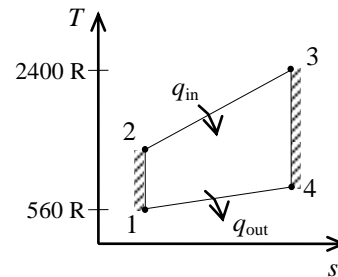
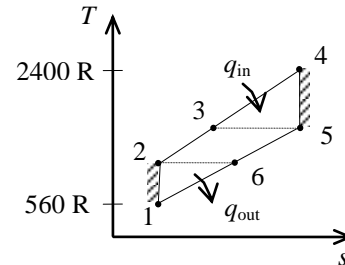

9-103E A car is powered by a gas turbine with a pressure ratio of 4. The thermal efficiency of the car and the mass flow rate of air for a net power output of 130 hp are to be determined.

Assumptions 1 Steady operating conditions exist. **2** Air is an ideal gas with variable specific heats. **3** The ambient air is 540 R and 14.5 psia. **4** The effectiveness of the regenerator is 0.9, and the isentropic efficiencies for both the compressor and the turbine are 80%. **5** The combustion gases can be treated as air.

Properties The properties of air at the compressor and turbine inlet temperatures can be obtained from Table A-17E.

Analysis The gas turbine cycle with regeneration can be analyzed as follows:

$$T_1 = 510 \text{ R} \longrightarrow \begin{matrix} h_1 = 121.88 \text{ Btu/lbm} \\ P_{r_1} = 1.1369 \end{matrix}$$

$$P_{r_2} = \frac{P_2}{P_1} P_{r_1} = (4)(1.1369) = 4.548 \longrightarrow h_{2s} = 181.39 \text{ Btu/lbm}$$

$$T_3 = 2160 \text{ R} \longrightarrow \begin{matrix} h_3 = 549.35 \text{ Btu/lbm} \\ P_{r_3} = 230.12 \end{matrix}$$

$$P_{r_4} = \frac{P_4}{P_3} P_{r_3} = \left(\frac{1}{4}\right)(230.12) = 57.53 \longrightarrow h_{4s} = 372.2 \text{ Btu/lbm}$$

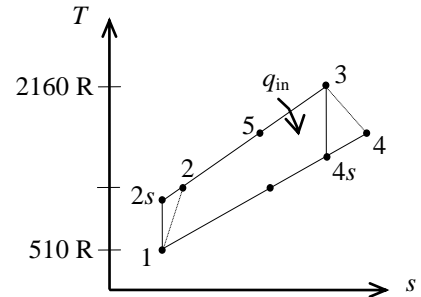

and

$$\eta_{\text{comp}} = \frac{h_{2s} - h_1}{h_2 - h_1} \rightarrow 0.80 = \frac{181.39 - 121.88}{h_2 - 121.88} \rightarrow h_2 = 196.27 \text{ Btu/lbm}$$

$$\eta_{\text{turb}} = \frac{h_3 - h_4}{h_3 - h_{4s}} \rightarrow 0.80 = \frac{549.35 - h_4}{549.35 - 372.2} \rightarrow h_4 = 407.63 \text{ Btu/lbm}$$

Then the thermal efficiency of the gas turbine cycle becomes

$$q_{\text{regen}} = \varepsilon(h_4 - h_2) = 0.9(407.63 - 196.27) = 190.2 \text{ Btu/lbm}$$

$$q_{\text{in}} = (h_3 - h_2) - q_{\text{regen}} = (549.35 - 196.27) - 190.2 = 162.9 \text{ Btu/lbm}$$

$$w_{\text{net,out}} = w_{\text{T,out}} - w_{\text{C,in}} = (h_3 - h_4) - (h_2 - h_1) = (549.35 - 407.63) - (196.27 - 121.88) = 67.33 \text{ Btu/lbm}$$

$$\eta_{\text{th}} = \frac{w_{\text{net,out}}}{q_{\text{in}}} = \frac{67.33 \text{ Btu/lbm}}{162.9 \text{ Btu/lbm}} = 0.413 = \mathbf{41.3\%}$$

Finally, the mass flow rate of air through the turbine becomes

$$\dot{m}_{\text{air}} = \frac{\dot{W}_{\text{net}}}{w_{\text{net,out}}} = \frac{130 \text{ hp}}{67.33 \text{ Btu/lbm}} \left(\frac{0.7068 \text{ Btu/s}}{1 \text{ hp}} \right) = \mathbf{1.36 \text{ lbm/s}}$$

9-104 An ideal Brayton cycle with regeneration is considered. The effectiveness of the regenerator is 100%. The net work output and the thermal efficiency of the cycle are to be determined.

Assumptions 1 The air standard assumptions are applicable. **2** Air is an ideal gas with variable specific heats. **3** Kinetic and potential energy changes are negligible.

Properties The properties of air are given in Table A-17.

Analysis Noting that this is an ideal cycle and thus the compression and expansion processes are isentropic, we have

$$T_1 = 300 \text{ K} \longrightarrow \begin{aligned} h_1 &= 300.19 \text{ kJ/kg} \\ P_{r_1} &= 1.386 \end{aligned}$$

$$P_{r_2} = \frac{P_2}{P_1} P_{r_1} = (10)(1.386) = 13.86 \longrightarrow h_2 = 579.87 \text{ kJ/kg}$$

$$T_3 = 1200 \text{ K} \longrightarrow \begin{aligned} h_3 &= 1277.79 \text{ kJ/kg} \\ P_{r_3} &= 238 \end{aligned}$$

$$P_{r_4} = \frac{P_4}{P_3} P_{r_3} = \left(\frac{1}{10}\right)(238) = 23.8 \longrightarrow h_4 = 675.85 \text{ kJ/kg}$$

$$w_{C,\text{in}} = h_2 - h_1 = 579.87 - 300.19 = 279.68 \text{ kJ/kg}$$

$$w_{T,\text{out}} = h_3 - h_4 = 1277.79 - 675.85 = 601.94 \text{ kJ/kg}$$

Thus,

$$w_{\text{net}} = w_{T,\text{out}} - w_{C,\text{in}} = 601.94 - 279.68 = \mathbf{322.26 \text{ kJ/kg}}$$

Also, $\varepsilon = 100\% \longrightarrow h_5 = h_4 = 675.85 \text{ kJ/kg}$

$$q_{\text{in}} = h_3 - h_5 = 1277.79 - 675.85 = 601.94 \text{ kJ/kg}$$

and

$$\eta_{\text{th}} = \frac{w_{\text{net}}}{q_{\text{in}}} = \frac{322.26 \text{ kJ/kg}}{601.94 \text{ kJ/kg}} = \mathbf{53.5\%}$$

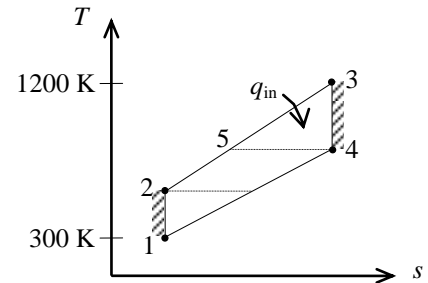



9-105 Problem 9-104 is reconsidered. The effects of the isentropic efficiencies for the compressor and turbine and regenerator effectiveness on net work done and the heat supplied to the cycle are to be studied. Also, the T - s diagram for the cycle is to be plotted.

Analysis Using EES, the problem is solved as follows:

```
"Input data"
T[3] = 1200 [K]
Pratio = 10
T[1] = 300 [K]
P[1] = 100 [kPa]
Eta_reg = 1.0
Eta_c = 0.8 "Compressor isentropic efficiency"
Eta_t = 0.9 "Turbine isentropic efficiency"

"Isentropic Compressor analysis"
s[1] = ENTROPY(Air, T=T[1], P=P[1])
s_s[2] = s[1] "For the ideal case the entropies are constant across the compressor"
P[2] = Pratio * P[1]
s_s[2] = ENTROPY(Air, T=T_s[2], P=P[2])
"T_s[2] is the isentropic value of T[2] at compressor exit"
Eta_c = w_compisen / w_comp
"compressor adiabatic efficiency, W_comp > W_compisen"
"Conservation of energy for the compressor for the isentropic case:
e_in - e_out = DELTAe = 0 for steady-flow"
h[1] + w_compisen = h_s[2]
h[1] = ENTHALPY(Air, T=T[1])
h_s[2] = ENTHALPY(Air, T=T_s[2])
"Actual compressor analysis:"
h[1] + w_comp = h[2]
h[2] = ENTHALPY(Air, T=T[2])
s[2] = ENTROPY(Air, T=T[2], P=P[2])
"External heat exchanger analysis"
"SSSF First Law for the heat exchanger, assuming W=0, ke=pe=0
e_in - e_out = DELTAe_cv = 0 for steady flow"
h[2] + q_in_noreg = h[3]
h[3] = ENTHALPY(Air, T=T[3])
P[3] = P[2] "process 2-3 is SSSF constant pressure"
"Turbine analysis"
s[3] = ENTROPY(Air, T=T[3], P=P[3])
s_s[4] = s[3] "For the ideal case the entropies are constant across the turbine"
P[4] = P[3] / Pratio
s_s[4] = ENTROPY(Air, T=T_s[4], P=P[4]) "T_s[4] is the isentropic value of T[4] at turbine exit"
Eta_t = w_turb / w_turbisen "turbine adiabatic efficiency, w_turbisen > w_turb"
"SSSF First Law for the isentropic turbine, assuming: adiabatic, ke=pe=0
e_in - e_out = DELTAe_cv = 0 for steady-flow"
h[3] = w_turbisen + h_s[4]
h_s[4] = ENTHALPY(Air, T=T_s[4])
"Actual Turbine analysis:"
h[3] = w_turb + h[4]
h[4] = ENTHALPY(Air, T=T[4])
s[4] = ENTROPY(Air, T=T[4], P=P[4])
"Cycle analysis"
w_net = w_turb - w_comp
Eta_th_noreg = w_net / q_in_noreg * Convert(, %) "[%]" "Cycle thermal efficiency"
Bwr = w_comp / w_turb "Back work ratio"

"With the regenerator the heat added in the external heat exchanger is"
h[5] + q_in_withreg = h[3]
```

$h[5]=\text{ENTHALPY}(\text{Air}, T=T[5])$
 $s[5]=\text{ENTROPY}(\text{Air}, T=T[5], P=P[5])$
 $P[5]=P[2]$

"The regenerator effectiveness gives $h[5]$ and thus $T[5]$ as:"

$\text{Eta_reg} = (h[5]-h[2])/(h[4]-h[2])$

"Energy balance on regenerator gives $h[6]$ and thus $T[6]$ as:"

$h[2] + h[4]=h[5] + h[6]$

$h[6]=\text{ENTHALPY}(\text{Air}, T=T[6])$

$s[6]=\text{ENTROPY}(\text{Air}, T=T[6], P=P[6])$

$P[6]=P[4]$

"Cycle thermal efficiency with regenerator"

$\text{Eta_th_withreg}=w_{\text{net}}/q_{\text{in_withreg}}*\text{Convert}(, \%)"["\%"]$

"The following data is used to complete the Array Table for plotting purposes."

$s_s[1]=s[1]$

$T_s[1]=T[1]$

$s_s[3]=s[3]$

$T_s[3]=T[3]$

$s_s[5]=\text{ENTROPY}(\text{Air}, T=T[5], P=P[5])$

$T_s[5]=T[5]$

$s_s[6]=s[6]$

$T_s[6]=T[6]$

η_c	η_t	$\eta_{\text{th, noreg}}$	$\eta_{\text{th, withreg}}$	q_{innoreg} [kJ/kg]	$q_{\text{inwithreg}}$ [kJ/kg]	W_{net} [kJ/kg]
0.6	0.9	14.76	13.92	510.9	541.6	75.4
0.65	0.9	20.35	20.54	546.8	541.6	111.3
0.7	0.9	24.59	26.22	577.5	541.6	142
0.75	0.9	27.91	31.14	604.2	541.6	168.6
0.8	0.9	30.59	35.44	627.5	541.6	192
0.85	0.9	32.79	39.24	648	541.6	212.5
0.9	0.9	34.64	42.61	666.3	541.6	230.8

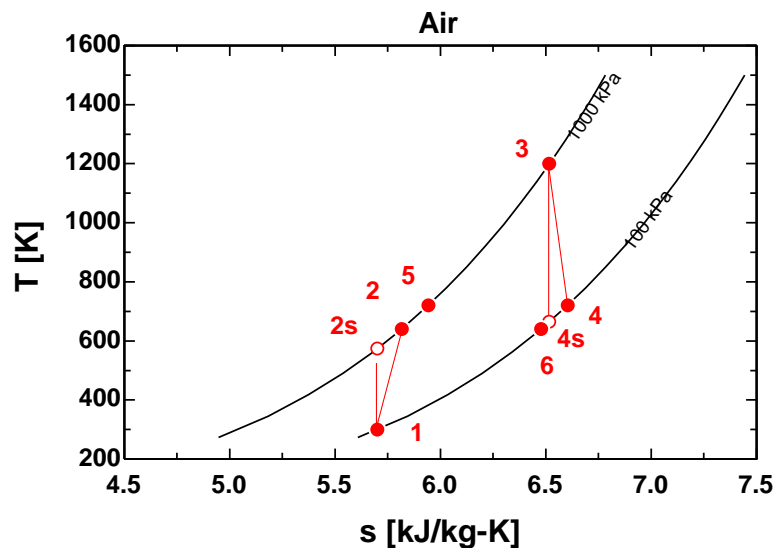

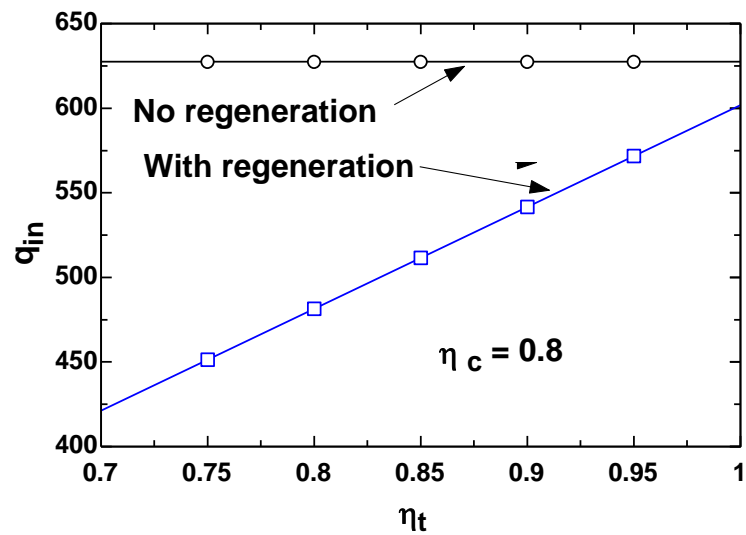
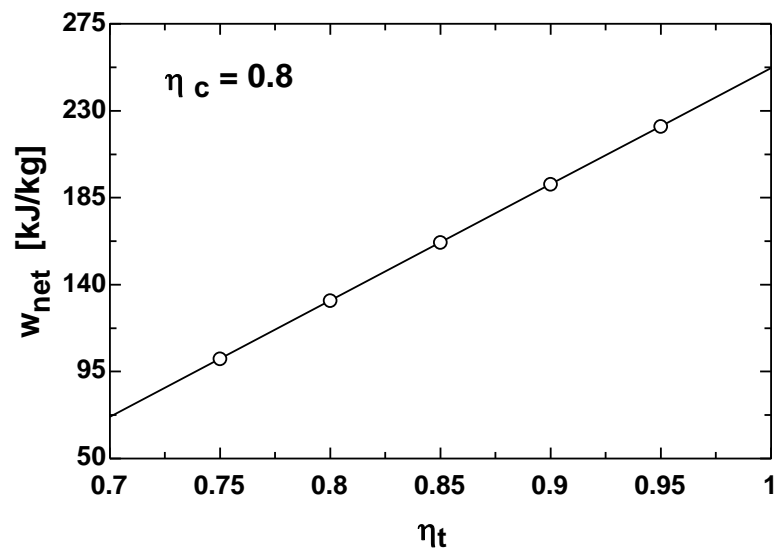
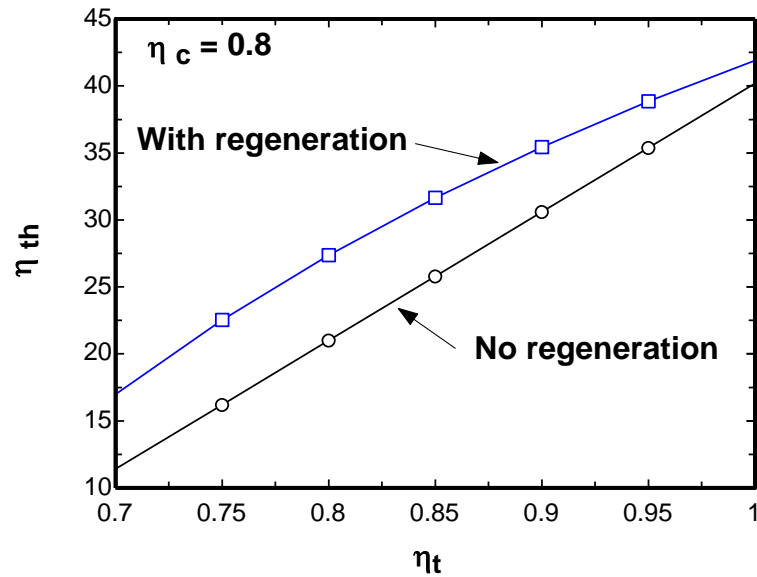

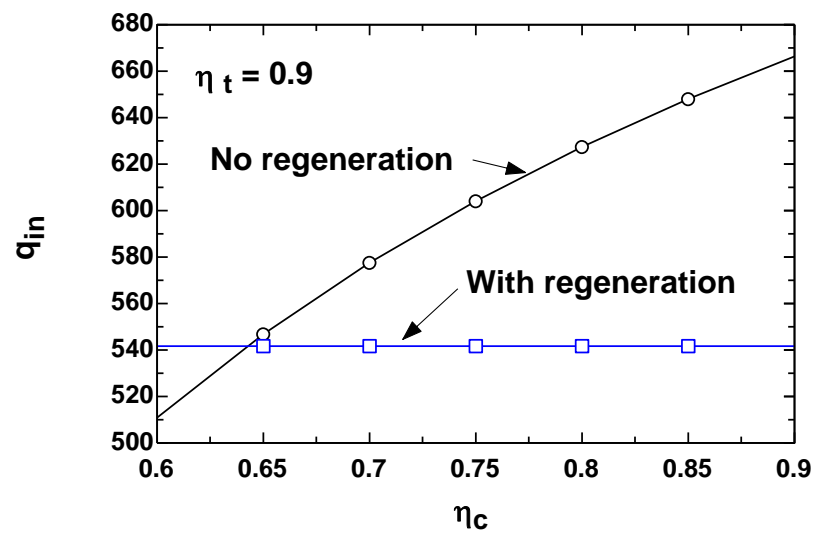
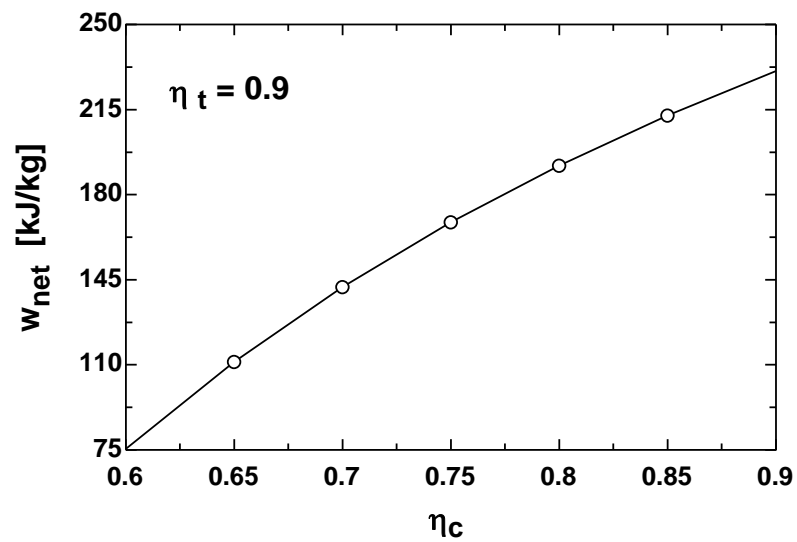
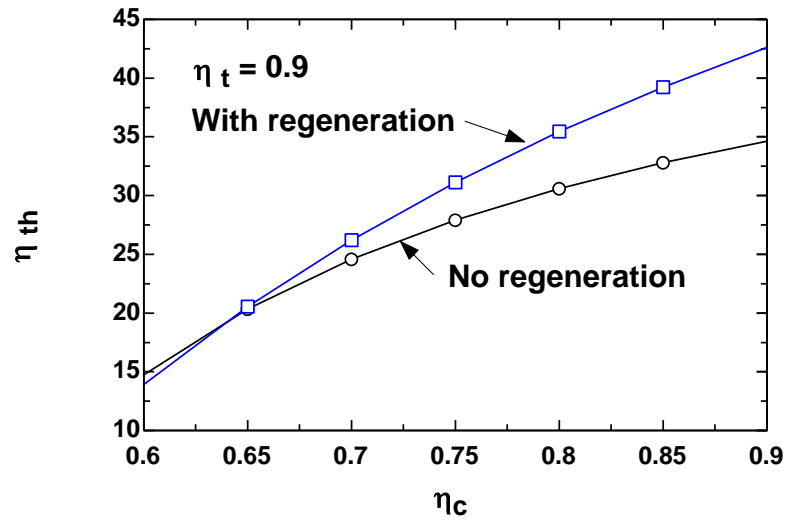

9-106 An ideal Brayton cycle with regeneration is considered. The effectiveness of the regenerator is 100%. The net work output and the thermal efficiency of the cycle are to be determined.

Assumptions 1 The air standard assumptions are applicable. **2** Air is an ideal gas with constant specific heats at room temperature. **3** Kinetic and potential energy changes are negligible.

Properties The properties of air at room temperature are $c_p = 1.005 \text{ kJ/kg}\cdot\text{K}$ and $k = 1.4$ (Table A-2a).

Analysis Noting that this is an ideal cycle and thus the compression and expansion processes are isentropic, we have

$$T_2 = T_1 \left(\frac{P_2}{P_1} \right)^{(k-1)/k} = (300 \text{ K})(10)^{0.4/1.4} = 579.2 \text{ K}$$

$$T_4 = T_3 \left(\frac{P_4}{P_3} \right)^{(k-1)/k} = (1200 \text{ K}) \left(\frac{1}{10} \right)^{0.4/1.4} = 621.5 \text{ K}$$

$$\varepsilon = 100\% \longrightarrow T_5 = T_4 = 621.5 \text{ K and } T_6 = T_2 = 579.2 \text{ K}$$

$$\eta_{\text{th}} = 1 - \frac{q_{\text{out}}}{q_{\text{in}}} = 1 - \frac{c_p(T_6 - T_1)}{c_p(T_3 - T_5)} = 1 - \frac{T_6 - T_1}{T_3 - T_5} = 1 - \frac{579.2 - 300}{1200 - 621.5} = \mathbf{0.517}$$

or

$$\eta_{\text{th}} = 1 - \left(\frac{T_1}{T_3} \right) r_p^{(k-1)/k} = 1 - \left(\frac{300}{1200} \right) (10)^{(1.4-1)/1.4} = 0.517$$

Then,

$$\begin{aligned} w_{\text{net}} &= w_{\text{turb,out}} - w_{\text{comp,in}} = (h_3 - h_4) - (h_2 - h_1) \\ &= c_p [(T_3 - T_4) - (T_2 - T_1)] \\ &= (1.005 \text{ kJ/kg}\cdot\text{K}) [(1200 - 621.5) - (579.2 - 300)] \text{ K} \\ &= \mathbf{300.8 \text{ kJ/kg}} \end{aligned}$$

or

$$\begin{aligned} w_{\text{net}} &= \eta_{\text{th}} q_{\text{in}} \\ &= \eta_{\text{th}} (h_3 - h_5) \\ &= \eta_{\text{th}} c_p (T_3 - T_5) \\ &= (0.517)(1.005 \text{ kJ/kg}\cdot\text{K})(1200 - 621.5) \\ &= \mathbf{300.6 \text{ kJ/kg}} \end{aligned}$$

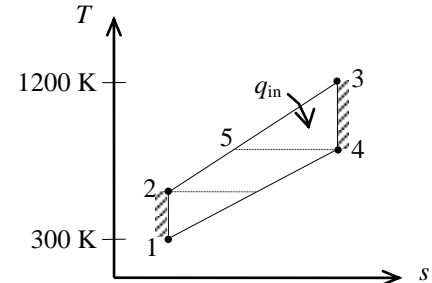

9-107 A Brayton cycle with regeneration using air as the working fluid is considered. The air temperature at the turbine exit, the net work output, and the thermal efficiency are to be determined.

Assumptions 1 The air standard assumptions are applicable. **2** Air is an ideal gas with variable specific heats. **3** Kinetic and potential energy changes are negligible.

Properties The properties of air are given in Table A-17.

Analysis (a) The properties of air at various states are

$$T_1 = 310 \text{ K} \longrightarrow \begin{aligned} h_1 &= 310.24 \text{ kJ/kg} \\ P_{r_1} &= 1.5546 \end{aligned}$$

$$P_{r_2} = \frac{P_2}{P_1} P_{r_1} = (7)(1.5546) = 10.88 \longrightarrow h_{2s} = 541.26 \text{ kJ/kg}$$

$$\eta_C = \frac{h_{2s} - h_1}{h_2 - h_1} \longrightarrow h_2 = h_1 + (h_{2s} - h_1)/\eta_C = 310.24 + (541.26 - 310.24)/(0.75) = 618.26 \text{ kJ/kg}$$

$$T_3 = 1150 \text{ K} \longrightarrow \begin{aligned} h_3 &= 1219.25 \text{ kJ/kg} \\ P_{r_3} &= 200.15 \end{aligned}$$

$$P_{r_4} = \frac{P_4}{P_3} P_{r_3} = \left(\frac{1}{7}\right)(200.15) = 28.59 \longrightarrow h_{4s} = 711.80 \text{ kJ/kg}$$

$$\eta_T = \frac{h_3 - h_4}{h_3 - h_{4s}} \longrightarrow h_4 = h_3 - \eta_T(h_3 - h_{4s}) = 1219.25 - (0.82)(1219.25 - 711.80) = 803.14 \text{ kJ/kg}$$

Thus,

$$T_4 = \mathbf{782.8 \text{ K}}$$

$$\begin{aligned} (b) \quad w_{\text{net}} &= w_{T,\text{out}} - w_{C,\text{in}} = (h_3 - h_4) - (h_2 - h_1) \\ &= (1219.25 - 803.14) - (618.26 - 310.24) \\ &= \mathbf{108.09 \text{ kJ/kg}} \end{aligned}$$

$$\begin{aligned} (c) \quad \varepsilon &= \frac{h_5 - h_2}{h_4 - h_2} \longrightarrow h_5 = h_2 + \varepsilon(h_4 - h_2) \\ &= 618.26 + (0.65)(803.14 - 618.26) \\ &= 738.43 \text{ kJ/kg} \end{aligned}$$

Then,

$$q_{\text{in}} = h_3 - h_5 = 1219.25 - 738.43 = 480.82 \text{ kJ/kg}$$

$$\eta_{\text{th}} = \frac{w_{\text{net}}}{q_{\text{in}}} = \frac{108.09 \text{ kJ/kg}}{480.82 \text{ kJ/kg}} = \mathbf{22.5\%}$$

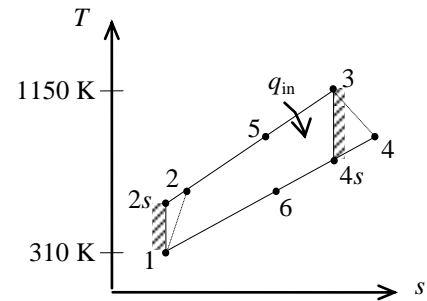

9-108 A stationary gas-turbine power plant operating on an ideal regenerative Brayton cycle with air as the working fluid is considered. The power delivered by this plant is to be determined for two cases.

Assumptions 1 The air standard assumptions are applicable. **2** Air is an ideal gas. **3** Kinetic and potential energy changes are negligible.

Properties When assuming constant specific heats, the properties of air at room temperature are $c_p = 1.005 \text{ kJ/kg}\cdot\text{K}$ and $k = 1.4$ (Table A-2a). When assuming variable specific heats, the properties of air are obtained from Table A-17.

Analysis The pressure ratio is

$$\frac{P_2}{P_1} = \frac{880 \text{ kPa}}{95 \text{ kPa}} = 9.263$$

(a) Assuming constant specific heats,

$$T_2 = T_1 \left(\frac{P_2}{P_1} \right)^{(k-1)/k} = (290 \text{ K})(9.263)^{0.4/1.4} = 547.8 \text{ K}$$

$$T_4 = T_3 \left(\frac{P_4}{P_3} \right)^{(k-1)/k} = (1100 \text{ K}) \left(\frac{1}{9.263} \right)^{0.4/1.4} = 582.3 \text{ K}$$

$$\varepsilon = 100\% \longrightarrow T_5 = T_4 = 582.3 \text{ K} \text{ and } T_6 = T_2 = 547.8 \text{ K}$$

$$\eta_{\text{th}} = 1 - \frac{q_{\text{out}}}{q_{\text{in}}} = 1 - \frac{c_p(T_6 - T_1)}{c_p(T_3 - T_5)} = 1 - \frac{T_6 - T_1}{T_3 - T_5} = 1 - \frac{547.8 - 290}{1100 - 582.3} = 0.5020$$

$$\dot{W}_{\text{net}} = \eta_T \dot{Q}_{\text{in}} = (0.5020)(30,000 \text{ kW}) = \mathbf{15,060 \text{ kW}}$$

(b) Assuming variable specific heats,

$$T_1 = 290 \text{ K} \longrightarrow \begin{aligned} h_1 &= 290.16 \text{ kJ/kg} \\ P_{r_1} &= 1.2311 \end{aligned}$$

$$P_{r_2} = \frac{P_2}{P_1} P_{r_1} = (9.263)(1.2311) = 11.40 \longrightarrow h_2 = 548.85 \text{ kJ/kg}$$

$$T_3 = 1100 \text{ K} \longrightarrow \begin{aligned} h_3 &= 1161.07 \text{ kJ/kg} \\ P_{r_3} &= 167.1 \end{aligned}$$

$$P_{r_4} = \frac{P_4}{P_3} P_{r_3} = \left(\frac{1}{9.263} \right) (167.1) = 18.04 \longrightarrow h_4 = 624.89 \text{ kJ/kg}$$

$$\varepsilon = 100\% \longrightarrow h_5 = h_4 = 624.89 \text{ kJ/kg} \text{ and } h_6 = h_2 = 548.85 \text{ kJ/kg}$$

$$\eta_{\text{th}} = 1 - \frac{q_{\text{out}}}{q_{\text{in}}} = 1 - \frac{h_6 - h_1}{h_3 - h_5} = 1 - \frac{548.85 - 290.16}{1161.07 - 624.89} = 0.5175$$

$$\dot{W}_{\text{net}} = \eta_T \dot{Q}_{\text{in}} = (0.5175)(30,000 \text{ kW}) = \mathbf{15,525 \text{ kW}}$$

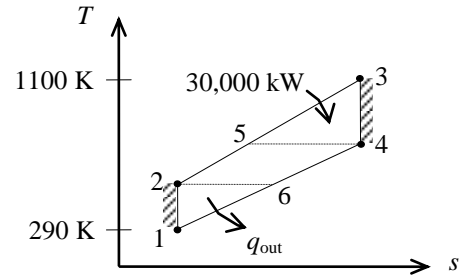

9-109 A regenerative gas-turbine engine using air as the working fluid is considered. The amount of heat transfer in the regenerator and the thermal efficiency are to be determined.

Assumptions 1 The air standard assumptions are applicable. **2** Air is an ideal gas with variable specific heats. **3** Kinetic and potential energy changes are negligible.

Properties The properties of air are given in Table A-17.

Analysis (a) The properties at various states are

$$r_p = P_2 / P_1 = 900 / 100 = 9$$

$$T_1 = 310 \text{ K} \longrightarrow h_1 = 310.24 \text{ kJ/kg}$$

$$T_2 = 650 \text{ K} \longrightarrow h_2 = 659.84 \text{ kJ/kg}$$

$$T_3 = 1400 \text{ K} \longrightarrow h_3 = 1515.42 \text{ kJ/kg}$$

$$P_{r_3} = 450.5$$

$$P_{r_4} = \frac{P_4}{P_3} P_{r_3} = \left(\frac{1}{9}\right)(450.5) = 50.06 \longrightarrow h_{4s} = 832.44 \text{ kJ/kg}$$

$$\begin{aligned} \eta_T = \frac{h_3 - h_4}{h_3 - h_{4s}} &\longrightarrow h_4 = h_3 - \eta_T (h_3 - h_{4s}) \\ &= 1515.42 - (0.90)(1515.42 - 832.44) \\ &= 900.74 \text{ kJ/kg} \end{aligned}$$

$$q_{\text{regen}} = \varepsilon(h_4 - h_2) = (0.80)(900.74 - 659.84) = \mathbf{192.7 \text{ kJ/kg}}$$

$$\begin{aligned} (b) \quad w_{\text{net}} = w_{T,\text{out}} - w_{C,\text{in}} &= (h_3 - h_4) - (h_2 - h_1) \\ &= (1515.42 - 900.74) - (659.84 - 310.24) = 265.08 \text{ kJ/kg} \end{aligned}$$

$$q_{\text{in}} = (h_3 - h_2) - q_{\text{regen}} = (1515.42 - 659.84) - 192.7 = 662.88 \text{ kJ/kg}$$

$$\eta_{\text{th}} = \frac{w_{\text{net}}}{q_{\text{in}}} = \frac{265.08 \text{ kJ/kg}}{662.88 \text{ kJ/kg}} = 0.400 = \mathbf{40.0\%}$$

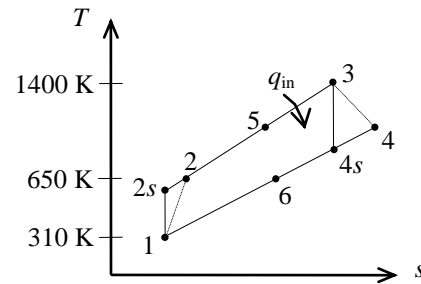

9-110 A regenerative gas-turbine engine using air as the working fluid is considered. The amount of heat transfer in the regenerator and the thermal efficiency are to be determined.

Assumptions 1 The air standard assumptions are applicable. **2** Air is an ideal gas with constant specific heats. **3** Kinetic and potential energy changes are negligible.

Properties The properties of air at room temperature are $c_p = 1.005 \text{ kJ/kg}\cdot\text{K}$ and $k = 1.4$ (Table A-2a).

Analysis (a) Using the isentropic relations and turbine efficiency,

$$r_p = P_2 / P_1 = 900 / 100 = 9$$

$$T_{4s} = T_3 \left(\frac{P_4}{P_3} \right)^{(k-1)/k} = (1400 \text{ K}) \left(\frac{1}{9} \right)^{0.4/1.4} = 747.3 \text{ K}$$

$$\eta_T = \frac{h_3 - h_4}{h_3 - h_{4s}} = \frac{c_p(T_3 - T_4)}{c_p(T_3 - T_{4s})} \longrightarrow T_4 = T_3 - \eta_T(T_3 - T_{4s})$$

$$= 1400 - (0.90)(1400 - 747.3)$$

$$= 812.6 \text{ K}$$

$$q_{\text{regen}} = \varepsilon(h_4 - h_2) = \varepsilon c_p(T_4 - T_2) = (0.80)(1.005 \text{ kJ/kg}\cdot\text{K})(812.6 - 650)\text{K} = \mathbf{130.7 \text{ kJ/kg}}$$

$$(b) \quad w_{\text{net}} = w_{T,\text{out}} - w_{C,\text{in}} = c_p(T_3 - T_4) - c_p(T_2 - T_1)$$

$$= (1.005 \text{ kJ/kg}\cdot\text{K})[(1400 - 812.6) - (650 - 310)]\text{K} = 248.7 \text{ kJ/kg}$$

$$q_{\text{in}} = (h_3 - h_2) - q_{\text{regen}} = c_p(T_3 - T_2) - q_{\text{regen}}$$

$$= (1.005 \text{ kJ/kg}\cdot\text{K})(1400 - 650)\text{K} - 130.7 = 623.1 \text{ kJ/kg}$$

$$\eta_{\text{th}} = \frac{w_{\text{net}}}{q_{\text{in}}} = \frac{248.7 \text{ kJ/kg}}{623.1 \text{ kJ/kg}} = 0.399 = \mathbf{39.9\%}$$

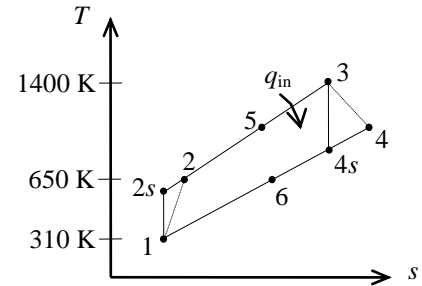

9-111 A regenerative gas-turbine engine using air as the working fluid is considered. The amount of heat transfer in the regenerator and the thermal efficiency are to be determined.

Assumptions 1 The air standard assumptions are applicable. **2** Air is an ideal gas with variable specific heats. **3** Kinetic and potential energy changes are negligible.

Properties The properties of air are given in Table A-17.

Analysis (a) The properties at various states are

$$r_p = P_2 / P_1 = 900 / 100 = 9$$

$$T_1 = 310 \text{ K} \longrightarrow h_1 = 310.24 \text{ kJ/kg}$$

$$T_2 = 650 \text{ K} \longrightarrow h_2 = 659.84 \text{ kJ/kg}$$

$$T_3 = 1400 \text{ K} \longrightarrow h_3 = 1515.42 \text{ kJ/kg}$$

$$P_{r_3} = 450.5$$

$$P_{r_4} = \frac{P_4}{P_3} P_{r_3} = \left(\frac{1}{9}\right)(450.5) = 50.06 \longrightarrow h_{4s} = 832.44 \text{ kJ/kg}$$

$$\begin{aligned} \eta_T = \frac{h_3 - h_4}{h_3 - h_{4s}} &\longrightarrow h_4 = h_3 - \eta_T (h_3 - h_{4s}) \\ &= 1515.42 - (0.90)(1515.42 - 832.44) \\ &= 900.74 \text{ kJ/kg} \end{aligned}$$

$$q_{\text{regen}} = \varepsilon(h_4 - h_2) = (0.70)(900.74 - 659.84) = \mathbf{168.6 \text{ kJ/kg}}$$

$$\begin{aligned} (b) \quad w_{\text{net}} = w_{T,\text{out}} - w_{C,\text{in}} &= (h_3 - h_4) - (h_2 - h_1) \\ &= (1515.42 - 900.74) - (659.84 - 310.24) = 265.08 \text{ kJ/kg} \end{aligned}$$

$$q_{\text{in}} = (h_3 - h_2) - q_{\text{regen}} = (1515.42 - 659.84) - 168.6 = 687.18 \text{ kJ/kg}$$

$$\eta_{\text{th}} = \frac{w_{\text{net}}}{q_{\text{in}}} = \frac{265.08 \text{ kJ/kg}}{687.18 \text{ kJ/kg}} = 0.386 = \mathbf{38.6\%}$$

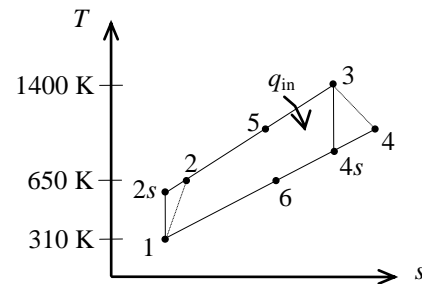

9-112 An expression for the thermal efficiency of an ideal Brayton cycle with an ideal regenerator is to be developed.

Assumptions 1 The air standard assumptions are applicable. **2** Air is an ideal gas with constant specific heats at room temperature. **3** Kinetic and potential energy changes are negligible.

Analysis The expressions for the isentropic compression and expansion processes are

$$T_2 = T_1 r_p^{(k-1)/k}$$

$$T_4 = T_3 \left(\frac{1}{r_p} \right)^{(k-1)/k}$$

For an ideal regenerator,

$$T_5 = T_4$$

$$T_6 = T_2$$

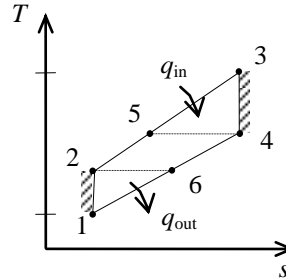

The thermal efficiency of the cycle is

$$\begin{aligned} \eta_{\text{th}} &= 1 - \frac{q_{\text{out}}}{q_{\text{in}}} = 1 - \frac{T_6 - T_1}{T_3 - T_5} = 1 - \frac{T_1 (T_6 / T_1) - 1}{T_3 (1 - (T_5 / T_3))} \\ &= 1 - \frac{T_1 (T_2 / T_1) - 1}{T_3 (1 - (T_4 / T_3))} \\ &= 1 - \frac{T_1 r_p^{(k-1)/k} - 1}{T_3 (1 - r_p^{-(k-1)/k})} \\ &= 1 - \frac{T_1}{T_3} r_p^{(k-1)/k} \end{aligned}$$

Brayton Cycle with Intercooling, Reheating, and Regeneration

9-113C Because the steady-flow work is proportional to the specific volume of the gas. Intercooling decreases the average specific volume of the gas during compression, and thus the compressor work. Reheating increases the average specific volume of the gas, and thus the turbine work output.

9-114C (a) decrease, (b) decrease, and (c) decrease.

9-115C (a) increase, (b) decrease, and (c) decrease.

9-116C (a) increase, (b) decrease, (c) decrease, and (d) increase.

9-117C (a) increase, (b) decrease, (c) increase, and (d) decrease.

9-118C (c) The Carnot (or Ericsson) cycle efficiency.

9-119 A regenerative gas-turbine cycle with two stages of compression and two stages of expansion is considered. The minimum mass flow rate of air needed to develop a specified net power output is to be determined.

Assumptions 1 The air standard assumptions are applicable. **2** Air is an ideal gas with variable specific heats. **3** Kinetic and potential energy changes are negligible.

Properties The properties of air are given in Table A-17.

Analysis The mass flow rate will be a minimum when the cycle is ideal. That is, the turbine and the compressors are isentropic, the regenerator has an effectiveness of 100%, and the compression ratios across each compression or expansion stage are identical. In our case it is $r_p = \sqrt{9} = 3$. Then the work inputs to each stage of compressor are identical, so are the work outputs of each stage of the turbine.

$$T_1 = 300 \text{ K} \longrightarrow h_1 = 300.19 \text{ kJ/kg}, \quad P_{r_1} = 1.386$$

$$P_{r_2} = \frac{P_2}{P_1} P_{r_1} = (3)(1.386) = 4.158 \longrightarrow h_2 = h_4 = 411.26 \text{ kJ/kg}$$

$$T_5 = 1200 \text{ K} \longrightarrow h_5 = h_7 = 1277.79 \text{ kJ/kg}, \quad P_{r_5} = 238$$

$$P_{r_6} = \frac{P_6}{P_5} P_{r_5} = \left(\frac{1}{3}\right)(238) = 79.33 \longrightarrow h_6 = h_8 = 946.36 \text{ kJ/kg}$$

$$w_{C,\text{in}} = 2(h_2 - h_1) = 2(411.26 - 300.19) = 222.14 \text{ kJ/kg}$$

$$w_{T,\text{out}} = 2(h_5 - h_6) = 2(1277.79 - 946.36) = 662.86 \text{ kJ/kg}$$

$$w_{\text{net}} = w_{T,\text{out}} - w_{C,\text{in}} = 662.86 - 222.14 = 440.72 \text{ kJ/kg}$$

$$\dot{m} = \frac{\dot{W}_{\text{net}}}{w_{\text{net}}} = \frac{110,000 \text{ kJ/s}}{440.72 \text{ kJ/kg}} = \mathbf{249.6 \text{ kg/s}}$$

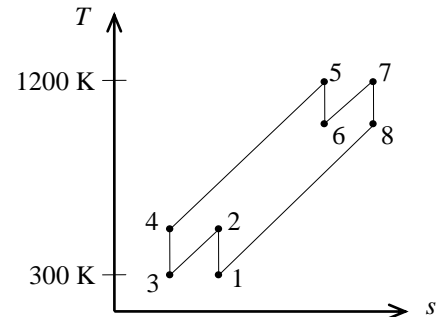

9-120 A regenerative gas-turbine cycle with two stages of compression and two stages of expansion is considered. The minimum mass flow rate of air needed to develop a specified net power output is to be determined.

Assumptions 1 Argon is an ideal gas with constant specific heats. **2** Kinetic and potential energy changes are negligible.

Properties The properties of argon at room temperature are $c_p = 0.5203 \text{ kJ/kg}\cdot\text{K}$ and $k = 1.667$ (Table A-2a).

Analysis The mass flow rate will be a minimum when the cycle is ideal. That is, the turbine and the compressors are isentropic, the regenerator has an effectiveness of 100%, and the compression ratios across each compression or expansion stage are identical. In our case it is $r_p = \sqrt{9} = 3$. Then the work inputs to each stage of compressor are identical, so are the work outputs of each stage of the turbine.

$$T_2 = T_1 \left(\frac{P_2}{P_1} \right)^{(k-1)/k} = (300 \text{ K})(3)^{0.667/1.667} = 465.6 \text{ K}$$

$$T_6 = T_5 \left(\frac{P_6}{P_5} \right)^{(k-1)/k} = (1200 \text{ K}) \left(\frac{1}{3} \right)^{0.667/1.667} = 773.2 \text{ K}$$

$$w_{C,\text{in}} = 2(h_2 - h_1) = 2c_p(T_2 - T_1) = 2(0.5203 \text{ kJ/kg}\cdot\text{K})(465.6 - 300)\text{K} = 172.3 \text{ kJ/kg}$$

$$w_{T,\text{out}} = 2(h_5 - h_6) = 2c_p(T_5 - T_6) = 2(0.5203 \text{ kJ/kg}\cdot\text{K})(1200 - 773.2)\text{K} = 444.1 \text{ kJ/kg}$$

$$w_{\text{net}} = w_{T,\text{out}} - w_{C,\text{in}} = 444.1 - 172.3 = 271.8 \text{ kJ/kg}$$

$$\dot{m} = \frac{\dot{W}_{\text{net}}}{w_{\text{net}}} = \frac{110,000 \text{ kJ/s}}{271.8 \text{ kJ/kg}} = \mathbf{404.7 \text{ kg/s}}$$

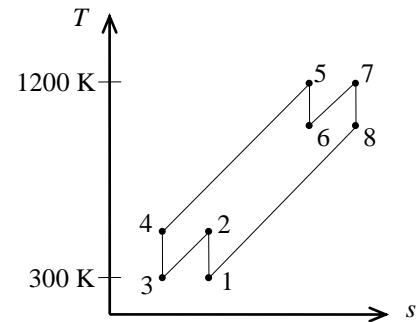

9-121 An ideal gas-turbine cycle with two stages of compression and two stages of expansion is considered. The back work ratio and the thermal efficiency of the cycle are to be determined for the cases of with and without a regenerator.

Assumptions 1 The air standard assumptions are applicable. **2** Air is an ideal gas with variable specific heats. **3** Kinetic and potential energy changes are negligible.

Properties The properties of air are given in Table A-17.

Analysis (a) The work inputs to each stage of compressor are identical, so are the work outputs of each stage of the turbine since this is an ideal cycle. Then,

$$T_1 = 300 \text{ K} \longrightarrow \begin{matrix} h_1 = 300.19 \text{ kJ/kg} \\ P_{r_1} = 1.386 \end{matrix}$$

$$P_{r_2} = \frac{P_2}{P_1} P_{r_1} = (3)(1.386) = 4.158 \longrightarrow h_2 = h_4 = 411.26 \text{ kJ/kg}$$

$$T_5 = 1200 \text{ K} \longrightarrow \begin{matrix} h_5 = h_7 = 1277.79 \text{ kJ/kg} \\ P_{r_5} = 238 \end{matrix}$$

$$P_{r_6} = \frac{P_6}{P_5} P_{r_5} = \left(\frac{1}{3}\right)(238) = 79.33 \longrightarrow h_6 = h_8 = 946.36 \text{ kJ/kg}$$

$$w_{C,\text{in}} = 2(h_2 - h_1) = 2(411.26 - 300.19) = 222.14 \text{ kJ/kg}$$

$$w_{T,\text{out}} = 2(h_5 - h_6) = 2(1277.79 - 946.36) = 662.86 \text{ kJ/kg}$$

Thus,

$$r_{\text{bw}} = \frac{w_{C,\text{in}}}{w_{T,\text{out}}} = \frac{222.14 \text{ kJ/kg}}{662.86 \text{ kJ/kg}} = \mathbf{33.5\%}$$

$$q_{\text{in}} = (h_5 - h_4) + (h_7 - h_6) = (1277.79 - 411.26) + (1277.79 - 946.36) = 1197.96 \text{ kJ/kg}$$

$$w_{\text{net}} = w_{T,\text{out}} - w_{C,\text{in}} = 662.86 - 222.14 = 440.72 \text{ kJ/kg}$$

$$\eta_{\text{th}} = \frac{w_{\text{net}}}{q_{\text{in}}} = \frac{440.72 \text{ kJ/kg}}{1197.96 \text{ kJ/kg}} = \mathbf{36.8\%}$$

(b) When a regenerator is used, r_{bw} remains the same. The thermal efficiency in this case becomes

$$q_{\text{regen}} = \varepsilon(h_8 - h_4) = (0.75)(946.36 - 411.26) = 401.33 \text{ kJ/kg}$$

$$q_{\text{in}} = q_{\text{in,old}} - q_{\text{regen}} = 1197.96 - 401.33 = 796.63 \text{ kJ/kg}$$

$$\eta_{\text{th}} = \frac{w_{\text{net}}}{q_{\text{in}}} = \frac{440.72 \text{ kJ/kg}}{796.63 \text{ kJ/kg}} = \mathbf{55.3\%}$$

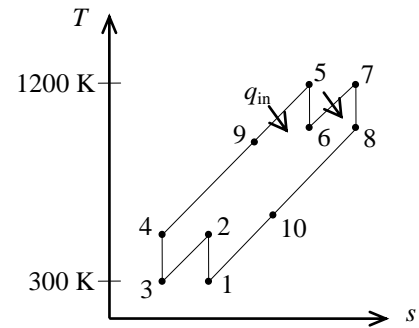

9-122 A gas-turbine cycle with two stages of compression and two stages of expansion is considered. The back work ratio and the thermal efficiency of the cycle are to be determined for the cases of with and without a regenerator.

Assumptions 1 The air standard assumptions are applicable. **2** Air is an ideal gas with variable specific heats. **3** Kinetic and potential energy changes are negligible.

Properties The properties of air are given in Table A-17.

Analysis (a) The work inputs to each stage of compressor are identical, so are the work outputs of each stage of the turbine. Then,

$$T_1 = 300 \text{ K} \longrightarrow h_1 = 300.19 \text{ kJ/kg}$$

$$P_{r_1} = 1.386$$

$$P_{r_2} = \frac{P_2}{P_1} P_{r_1} = (3)(1.386) = 4.158 \longrightarrow h_{2s} = h_{4s} = 411.26 \text{ kJ/kg}$$

$$\eta_C = \frac{h_{2s} - h_1}{h_2 - h_1} \longrightarrow h_2 = h_4 = h_1 + (h_{2s} - h_1) / \eta_C$$

$$= 300.19 + (411.26 - 300.19) / (0.86)$$

$$= 429.34 \text{ kJ/kg}$$

$$T_5 = 1200 \text{ K} \longrightarrow h_5 = h_7 = 1277.79 \text{ kJ/kg}$$

$$P_{r_5} = 238$$

$$P_{r_6} = \frac{P_6}{P_5} P_{r_5} = \left(\frac{1}{3}\right)(238) = 79.33 \longrightarrow h_{6s} = h_{8s} = 946.36 \text{ kJ/kg}$$

$$\eta_T = \frac{h_5 - h_6}{h_5 - h_{6s}} \longrightarrow h_6 = h_8 = h_5 - \eta_T (h_5 - h_{6s})$$

$$= 1277.79 - (0.90)(1277.79 - 946.36)$$

$$= 979.50 \text{ kJ/kg}$$

$$w_{C,\text{in}} = 2(h_2 - h_1) = 2(429.34 - 300.19) = 258.3 \text{ kJ/kg}$$

$$w_{T,\text{out}} = 2(h_5 - h_6) = 2(1277.79 - 979.50) = 596.6 \text{ kJ/kg}$$

Thus,

$$r_{\text{bw}} = \frac{w_{C,\text{in}}}{w_{T,\text{out}}} = \frac{258.3 \text{ kJ/kg}}{596.6 \text{ kJ/kg}} = 0.433 = \mathbf{43.3\%}$$

$$q_{\text{in}} = (h_5 - h_4) + (h_7 - h_6) = (1277.79 - 429.34) + (1277.79 - 979.50) = 1146.7 \text{ kJ/kg}$$

$$w_{\text{net}} = w_{T,\text{out}} - w_{C,\text{in}} = 596.6 - 258.3 = 338.3 \text{ kJ/kg}$$

$$\eta_{\text{th}} = \frac{w_{\text{net}}}{q_{\text{in}}} = \frac{338.3 \text{ kJ/kg}}{1146.7 \text{ kJ/kg}} = 0.295 = \mathbf{29.5\%}$$

(b) When a regenerator is used, r_{bw} remains the same. The thermal efficiency in this case becomes

$$q_{\text{regen}} = \varepsilon(h_8 - h_4) = (0.75)(979.50 - 429.34) = 412.6 \text{ kJ/kg}$$

$$q_{\text{in}} = q_{\text{in,old}} - q_{\text{regen}} = 1146.7 - 412.6 = 734.1 \text{ kJ/kg}$$

$$\eta_{\text{th}} = \frac{w_{\text{net}}}{q_{\text{in}}} = \frac{338.3 \text{ kJ/kg}}{734.1 \text{ kJ/kg}} = 0.461 = \mathbf{46.1\%}$$

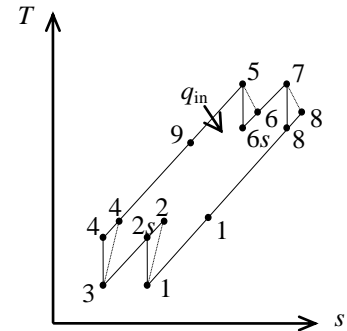

9-123 A regenerative gas-turbine cycle with two stages of compression and two stages of expansion is considered. The thermal efficiency of the cycle is to be determined.

Assumptions 1 The air standard assumptions are applicable. **2** Air is an ideal gas with constant specific heats at room temperature. **3** Kinetic and potential energy changes are negligible.

Properties The properties of air at room temperature are $c_p = 1.005 \text{ kJ/kg}\cdot\text{K}$ and $k = 1.4$ (Table A-2a).

Analysis The temperatures at various states are obtained as follows

$$T_2 = T_4 = T_1 r_p^{(k-1)/k} = (290 \text{ K})(4)^{0.4/1.4} = 430.9 \text{ K}$$

$$T_5 = T_4 + 20 = 430.9 + 20 = 450.9 \text{ K}$$

$$q_{\text{in}} = c_p (T_6 - T_5)$$

$$T_6 = T_5 + \frac{q_{\text{in}}}{c_p} = 450.9 \text{ K} + \frac{300 \text{ kJ/kg}}{1.005 \text{ kJ/kg}\cdot\text{K}} = 749.4 \text{ K}$$

$$T_7 = T_6 \left(\frac{1}{r_p} \right)^{(k-1)/k} = (749.4 \text{ K}) \left(\frac{1}{4} \right)^{0.4/1.4} = 504.3 \text{ K}$$

$$T_8 = T_7 + \frac{q_{\text{in}}}{c_p} = 504.3 \text{ K} + \frac{300 \text{ kJ/kg}}{1.005 \text{ kJ/kg}\cdot\text{K}} = 802.8 \text{ K}$$

$$T_9 = T_8 \left(\frac{1}{r_p} \right)^{(k-1)/k} = (802.8 \text{ K}) \left(\frac{1}{4} \right)^{0.4/1.4} = 540.2 \text{ K}$$

$$T_{10} = T_9 - 20 = 540.2 - 20 = 520.2 \text{ K}$$

The heat input is

$$q_{\text{in}} = 300 + 300 = 600 \text{ kJ/kg}$$

The heat rejected is

$$\begin{aligned} q_{\text{out}} &= c_p (T_{10} - T_1) + c_p (T_2 - T_3) \\ &= (1.005 \text{ kJ/kg}\cdot\text{K})(520.2 - 290 + 430.9 - 290) \text{ R} \\ &= 373.0 \text{ kJ/kg} \end{aligned}$$

The thermal efficiency of the cycle is then

$$\eta_{\text{th}} = 1 - \frac{q_{\text{out}}}{q_{\text{in}}} = 1 - \frac{373.0}{600} = \mathbf{0.378}$$

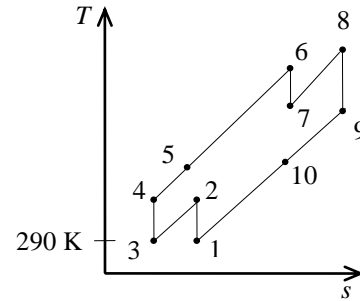

9-124 A regenerative gas-turbine cycle with three stages of compression and three stages of expansion is considered. The thermal efficiency of the cycle is to be determined.

Assumptions 1 The air standard assumptions are applicable. **2** Air is an ideal gas with constant specific heats at room temperature. **3** Kinetic and potential energy changes are negligible.

Properties The properties of air at room temperature are $c_p = 1.005 \text{ kJ/kg}\cdot\text{K}$ and $k = 1.4$ (Table A-2a).

Analysis The temperatures at various states are obtained as follows

$$T_2 = T_4 = T_6 = T_1 r_p^{(k-1)/k} = (290 \text{ K})(4)^{0.4/1.4} = 430.9 \text{ K}$$

$$T_7 = T_6 + 20 = 430.9 + 20 = 450.9 \text{ K}$$

$$q_{\text{in}} = c_p (T_8 - T_7)$$

$$T_8 = T_7 + \frac{q_{\text{in}}}{c_p} = 450.9 \text{ K} + \frac{300 \text{ kJ/kg}}{1.005 \text{ kJ/kg}\cdot\text{K}} = 749.4 \text{ K}$$

$$T_9 = T_8 \left(\frac{1}{r_p} \right)^{(k-1)/k} = (749.4 \text{ K}) \left(\frac{1}{4} \right)^{0.4/1.4} = 504.3 \text{ K}$$

$$T_{10} = T_9 + \frac{q_{\text{in}}}{c_p} = 504.3 \text{ K} + \frac{300 \text{ kJ/kg}}{1.005 \text{ kJ/kg}\cdot\text{K}} = 802.8 \text{ K}$$

$$T_{11} = T_{10} \left(\frac{1}{r_p} \right)^{(k-1)/k} = (802.8 \text{ K}) \left(\frac{1}{4} \right)^{0.4/1.4} = 540.2 \text{ K}$$

$$T_{12} = T_{11} + \frac{q_{\text{in}}}{c_p} = 540.2 \text{ K} + \frac{300 \text{ kJ/kg}}{1.005 \text{ kJ/kg}\cdot\text{K}} = 838.7 \text{ K}$$

$$T_{13} = T_{12} \left(\frac{1}{r_p} \right)^{(k-1)/k} = (838.7 \text{ K}) \left(\frac{1}{4} \right)^{0.4/1.4} = 564.4 \text{ K}$$

$$T_{14} = T_{13} - 20 = 564.4 - 20 = 544.4 \text{ K}$$

The heat input is

$$q_{\text{in}} = 300 + 300 + 300 = 900 \text{ kJ/kg}$$

The heat rejected is

$$\begin{aligned} q_{\text{out}} &= c_p (T_{14} - T_1) + c_p (T_2 - T_3) + c_p (T_4 - T_5) \\ &= (1.005 \text{ kJ/kg}\cdot\text{K})(544.4 - 290 + 430.9 - 290 + 430.9 - 290) \text{ R} \\ &= 538.9 \text{ kJ/kg} \end{aligned}$$

The thermal efficiency of the cycle is then

$$\eta_{\text{th}} = 1 - \frac{q_{\text{out}}}{q_{\text{in}}} = 1 - \frac{538.9}{900} = 0.401 = \mathbf{40.1\%}$$

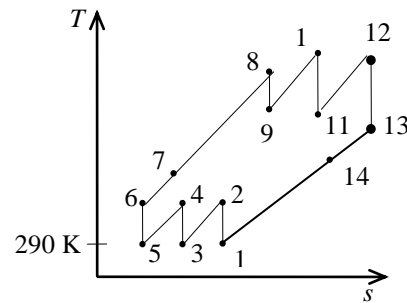

9-125 A regenerative gas-turbine cycle with three stages of compression and three stages of expansion is considered. The thermal efficiency of the cycle is to be determined.

Assumptions 1 The air standard assumptions are applicable. **2** Air is an ideal gas with constant specific heats at room temperature. **3** Kinetic and potential energy changes are negligible.

Properties The properties of air at room temperature are $c_p = 1.005 \text{ kJ/kg}\cdot\text{K}$ and $k = 1.4$ (Table A-2a).

Analysis Since all compressors share the same compression ratio and begin at the same temperature,

$$T_2 = T_4 = T_6 = T_1 r_p^{(k-1)/k} = (290 \text{ K})(4)^{0.4/1.4} = 430.9 \text{ K}$$

From the problem statement,

$$T_7 = T_{13} - 80$$

The relations for heat input and expansion processes are

$$q_{\text{in}} = c_p (T_8 - T_7) \longrightarrow T_8 = T_7 + \frac{q_{\text{in}}}{c_p}$$

$$T_9 = T_8 \left(\frac{1}{r_p} \right)^{(k-1)/k}$$

$$T_{10} = T_9 + \frac{q_{\text{in}}}{c_p}, \quad T_{11} = T_{10} \left(\frac{1}{r_p} \right)^{(k-1)/k}$$

$$T_{12} = T_{11} + \frac{q_{\text{in}}}{c_p}, \quad T_{13} = T_{12} \left(\frac{1}{r_p} \right)^{(k-1)/k}$$

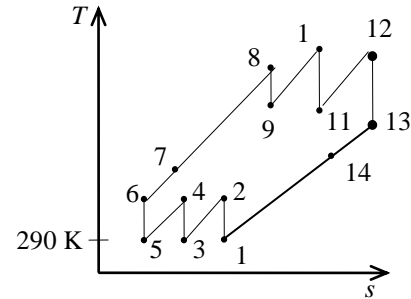

The simultaneous solution of above equations using EES software gives the following results

$$T_7 = 499.2 \text{ K}, \quad T_8 = 797.7 \text{ K}, \quad T_9 = 536.8 \text{ K}$$

$$T_{10} = 835.3 \text{ K}, \quad T_{11} = 562.1 \text{ K}, \quad T_{12} = 860.6 \text{ K}, \quad T_{13} = 579.2 \text{ K}$$

From an energy balance on the regenerator,

$$T_7 - T_6 = T_{13} - T_{14}$$

$$(T_{13} - 80) - T_6 = T_{13} - T_{14} \longrightarrow T_{14} = T_6 + 80 = 430.9 + 80 = 510.9 \text{ K}$$

The heat input is

$$q_{\text{in}} = 300 + 300 + 300 = 900 \text{ kJ/kg}$$

The heat rejected is

$$q_{\text{out}} = c_p (T_{14} - T_1) + c_p (T_2 - T_3) + c_p (T_4 - T_5)$$

$$= (1.005 \text{ kJ/kg}\cdot\text{K})(510.9 - 290 + 430.9 - 290 + 430.9 - 290) \text{ R}$$

$$= 505.3 \text{ kJ/kg}$$

The thermal efficiency of the cycle is then

$$\eta_{\text{th}} = 1 - \frac{q_{\text{out}}}{q_{\text{in}}} = 1 - \frac{505.3}{900} = 0.4385 = \mathbf{43.9\%}$$

Jet-Propulsion Cycles

9-126C The power developed from the thrust of the engine is called the propulsive power. It is equal to thrust times the aircraft velocity.

9-127C The ratio of the propulsive power developed and the rate of heat input is called the propulsive efficiency. It is determined by calculating these two quantities separately, and taking their ratio.

9-128C It reduces the exit velocity, and thus the thrust.

9-129E A turbojet engine operating on an ideal cycle is flying at an altitude of 20,000 ft. The pressure at the turbine exit, the velocity of the exhaust gases, and the propulsive efficiency are to be determined.

Assumptions 1 Steady operating conditions exist. 2 The air standard assumptions are applicable. 3 Air is an ideal gas with constant specific heats at room temperature. 4 Kinetic and potential energies are negligible, except at the diffuser inlet and the nozzle exit. 5 The turbine work output is equal to the compressor work input.

Properties The properties of air at room temperature are $c_p = 0.24 \text{ Btu/lbm}\cdot\text{R}$ and $k = 1.4$ (Table A-2Ea).

Analysis (a) For convenience, we assume the aircraft is stationary and the air is moving towards the aircraft at a velocity of $V_1 = 900 \text{ ft/s}$. Ideally, the air will leave the diffuser with a negligible velocity ($V_2 \cong 0$).

Diffuser:

$$\dot{E}_{\text{in}} - \dot{E}_{\text{out}} = \Delta \dot{E}_{\text{system}}^{\phi_0} \text{ (steady)}$$

$$\dot{E}_{\text{in}} = \dot{E}_{\text{out}}$$

$$h_1 + V_1^2 / 2 = h_2 + V_2^2 / 2$$

$$0 = h_2 - h_1 + \frac{V_2^2 - V_1^2}{2}$$

$$0 = c_p (T_2 - T_1) - V_1^2 / 2$$

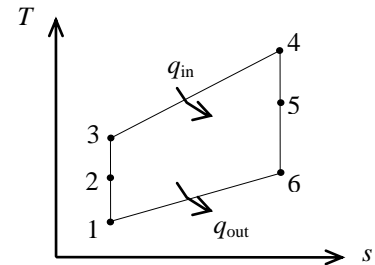

$$T_2 = T_1 + \frac{V_1^2}{2c_p} = 470 + \frac{(900 \text{ ft/s})^2}{(2)(0.24 \text{ Btu/lbm}\cdot\text{R})} \left(\frac{1 \text{ Btu/lbm}}{25,037 \text{ ft}^2/\text{s}^2} \right) = 537.4 \text{ R}$$

$$P_2 = P_1 \left(\frac{T_2}{T_1} \right)^{k/(k-1)} = (7 \text{ psia}) \left(\frac{537.3 \text{ R}}{470 \text{ R}} \right)^{1.4/0.4} = 11.19 \text{ psia}$$

Compressor:

$$P_3 = P_4 = (r_p)(P_2) = (13)(11.19 \text{ psia}) = 145.5 \text{ psia}$$

$$T_3 = T_2 \left(\frac{P_3}{P_2} \right)^{(k-1)/k} = (537.4 \text{ R})(13)^{0.4/1.4} = 1118.3 \text{ R}$$

Turbine:

$$w_{\text{comp,in}} = w_{\text{turb,out}} \longrightarrow h_3 - h_2 = h_4 - h_5 \longrightarrow c_p (T_3 - T_2) = c_p (T_4 - T_5)$$

or

$$T_5 = T_4 - T_3 + T_2 = 2400 - 1118.3 + 537.4 = 1819.1 \text{ R}$$

$$P_5 = P_4 \left(\frac{T_5}{T_4} \right)^{k/(k-1)} = (145.5 \text{ psia}) \left(\frac{1819.1 \text{ R}}{2400 \text{ R}} \right)^{1.4/0.4} = \mathbf{55.2 \text{ psia}}$$

(b) Nozzle:

$$T_6 = T_5 \left(\frac{P_6}{P_5} \right)^{(k-1)/k} = (1819.1 \text{ R}) \left(\frac{7 \text{ psia}}{55.2 \text{ psia}} \right)^{0.4/1.4} = 1008.6 \text{ R}$$

$$\begin{aligned}\dot{E}_{\text{in}} - \dot{E}_{\text{out}} &= \Delta \dot{E}_{\text{system}} \quad \phi^0 \text{ (steady)} \\ \dot{E}_{\text{in}} &= \dot{E}_{\text{out}} \\ h_5 + V_5^2 / 2 &= h_6 + V_6^2 / 2 \\ 0 &= h_6 - h_5 + \frac{V_6^2 - V_5^2}{2} \quad \phi^0 \\ 0 &= c_p (T_6 - T_5) + V_6^2 / 2\end{aligned}$$

or

$$V_6 = \sqrt{(2)(0.240 \text{ Btu/lbm} \cdot \text{R})(1819.1 - 1008.6) \text{R} \left(\frac{25,037 \text{ ft}^2/\text{s}^2}{1 \text{ Btu/lbm}} \right)} = \mathbf{3121 \text{ ft/s}}$$

(c) The propulsive efficiency is the ratio of the propulsive work to the heat input,

$$\begin{aligned}w_p &= (V_{\text{exit}} - V_{\text{inlet}}) V_{\text{aircraft}} \\ &= [(3121 - 900) \text{ ft/s}](900 \text{ ft/s}) \left(\frac{1 \text{ Btu/lbm}}{25,037 \text{ ft}^2/\text{s}^2} \right) = 79.8 \text{ Btu/lbm} \\ q_{\text{in}} &= h_4 - h_3 = c_p (T_4 - T_3) = (0.24 \text{ Btu/lbm} \cdot \text{R})(2400 - 1118.3) \text{R} = 307.6 \text{ Btu/lbm} \\ \eta_p &= \frac{w_p}{q_{\text{in}}} = \frac{79.8 \text{ Btu/lbm}}{307.6 \text{ Btu/lbm}} = \mathbf{25.9\%}\end{aligned}$$

9-130E A turbojet engine operating on an ideal cycle is flying at an altitude of 20,000 ft. The pressure at the turbine exit, the velocity of the exhaust gases, and the propulsive efficiency are to be determined.

Assumptions 1 Steady operating conditions exist. **2** The air standard assumptions are applicable. **3** Air is an ideal gas with variable specific heats. **4** Kinetic and potential energies are negligible, except at the diffuser inlet and the nozzle exit. **5** The turbine work output is equal to the compressor work input.

Properties The properties of air are given in Table A-17E.

Analysis (a) For convenience, we assume the aircraft is stationary and the air is moving towards the aircraft at a velocity of $V_1 = 900$ ft/s. Ideally, the air will leave the diffuser with a negligible velocity ($V_2 \cong 0$).

$$\text{Diffuser: } T_1 = 470 \text{ R} \longrightarrow h_1 = 112.20 \text{ Btu/lbm}$$

$$P_{r_1} = 0.8548$$

$$\dot{E}_{\text{in}} - \dot{E}_{\text{out}} = \Delta \dot{E}_{\text{system}} \stackrel{\neq 0}{\text{(steady)}}$$

$$\dot{E}_{\text{in}} = \dot{E}_{\text{out}}$$

$$h_1 + V_1^2 / 2 = h_2 + V_2^2 / 2$$

$$0 = h_2 - h_1 + \frac{V_2^2 - V_1^2}{2}$$

$$h_2 = h_1 + \frac{V_1^2}{2} = 112.20 + \frac{(900 \text{ ft/s})^2}{2} \left(\frac{1 \text{ Btu/lbm}}{25,037 \text{ ft}^2/\text{s}^2} \right) = 128.48 \text{ Btu/lbm} \longrightarrow P_{r_2} = 1.3698$$

$$P_2 = P_1 \left(\frac{P_{r_2}}{P_{r_1}} \right) = (7 \text{ psia}) \left(\frac{1.3698}{0.8548} \right) = 11.22 \text{ psia}$$

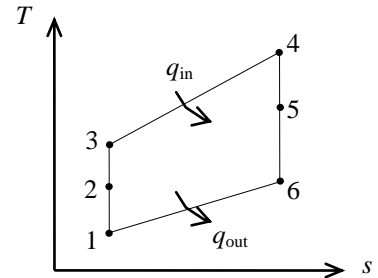

Compressor:

$$P_3 = P_4 = (r_p)(P_2) = (13)(11.22 \text{ psia}) = 145.8 \text{ psia}$$

$$P_{r_3} = \left(\frac{P_3}{P_2} \right) P_{r_2} = \left(\frac{145.8}{11.22} \right) (1.3698) = 17.80 \longrightarrow h_3 = 267.56 \text{ Btu/lbm}$$

$$\text{Turbine: } T_4 = 2400 \text{ R} \longrightarrow h_4 = 617.22 \text{ Btu/lbm}$$

$$P_{r_4} = 367.6$$

$$w_{\text{comp,in}} = w_{\text{turb,out}}$$

$$h_3 - h_2 = h_4 - h_5$$

or

$$h_5 = h_4 - h_3 + h_2 = 617.22 - 267.56 + 128.48 = 478.14 \text{ Btu/lbm} \longrightarrow P_{r_5} = 142.7$$

$$P_5 = P_4 \left(\frac{P_{r_5}}{P_{r_4}} \right) = (145.8 \text{ psia}) \left(\frac{142.7}{367.6} \right) = 56.6 \text{ psia}$$

(b) Nozzle:

$$P_{r_6} = P_{r_5} \left(\frac{P_6}{P_5} \right) = (142.7) \left(\frac{7 \text{ psia}}{56.6 \text{ psia}} \right) = 17.66 \longrightarrow h_6 = 266.93 \text{ Btu/lbm}$$

$$\begin{aligned}\dot{E}_{\text{in}} - \dot{E}_{\text{out}} &= \Delta \dot{E}_{\text{system}} \quad \phi^0 \text{ (steady)} \\ \dot{E}_{\text{in}} &= \dot{E}_{\text{out}} \\ h_5 + V_5^2 / 2 &= h_6 + V_6^2 / 2 \\ 0 &= h_6 - h_5 + \frac{V_6^2 - V_5^2}{2} \phi^0\end{aligned}$$

or

$$V_6 = \sqrt{2(h_5 - h_6)} = \sqrt{(2)(478.14 - 266.93)\text{Btu/lbm} \left(\frac{25,037 \text{ ft}^2/\text{s}^2}{1 \text{ Btu/lbm}} \right)} = \mathbf{3252 \text{ ft/s}}$$

(c) The propulsive efficiency is the ratio of the propulsive work to the heat input,

$$\begin{aligned}w_p &= (V_{\text{exit}} - V_{\text{inlet}})V_{\text{aircraft}} \\ &= [(3252 - 900) \text{ ft/s}](900 \text{ ft/s}) \left(\frac{1 \text{ Btu/lbm}}{25,037 \text{ ft}^2/\text{s}^2} \right) = 84.55 \text{ Btu/lbm} \\ q_{\text{in}} &= h_4 - h_3 = 617.22 - 267.56 = 349.66 \text{ Btu/lbm} \\ \eta_p &= \frac{w_p}{q_{\text{in}}} = \frac{84.55 \text{ Btu/lbm}}{349.66 \text{ Btu/lbm}} = \mathbf{24.2\%}\end{aligned}$$

9-131 A turbofan engine operating on an ideal cycle produces 50,000 N of thrust. The air temperature at the fan outlet needed to produce this thrust is to be determined.

Assumptions 1 Steady operating conditions exist. **2** The air standard assumptions are applicable. **3** Air is an ideal gas with constant specific heats at room temperature. **4** The turbine work output is equal to the compressor work input.

Properties The properties of air at room temperature are $R = 0.287 \text{ kPa}\cdot\text{m}^3/\text{kg}\cdot\text{K}$, $c_p = 1.005 \text{ kJ/kg}\cdot\text{K}$ and $k = 1.4$ (Table A-2a).

Analysis The total mass flow rate is

$$\nu_1 = \frac{RT}{P} = \frac{(0.287 \text{ kPa}\cdot\text{m}^3)(253 \text{ K})}{50 \text{ kPa}} = 1.452 \text{ m}^3/\text{kg}$$

$$\dot{m} = \frac{AV_1}{\nu_1} = \frac{\pi D^2 V_1}{4 \nu_1} = \frac{\pi(2.5 \text{ m})^2}{4} \frac{200 \text{ m/s}}{1.452 \text{ m}^3/\text{kg}} = 676.1 \text{ kg/s}$$

Now,

$$\dot{m}_e = \frac{\dot{m}}{8} = \frac{676.1 \text{ kg/s}}{8} = 84.51 \text{ kg/s}$$

The mass flow rate through the fan is

$$\dot{m}_f = \dot{m} - \dot{m}_e = 676.1 - 84.51 = 591.6 \text{ kg/s}$$

In order to produce the specified thrust force, the velocity at the fan exit will be

$$F = \dot{m}_f (V_{\text{exit}} - V_{\text{inlet}})$$

$$V_{\text{exit}} = V_{\text{inlet}} + \frac{F}{\dot{m}_f} = (200 \text{ m/s}) + \frac{50,000 \text{ N}}{591.6 \text{ kg/s}} \left(\frac{1 \text{ kg}\cdot\text{m/s}^2}{1 \text{ N}} \right) = 284.5 \text{ m/s}$$

An energy balance on the stream passing through the fan gives

$$c_p (T_4 - T_5) = \frac{V_{\text{exit}}^2 - V_{\text{inlet}}^2}{2}$$

$$T_5 = T_4 - \frac{V_{\text{exit}}^2 - V_{\text{inlet}}^2}{2c_p}$$

$$= 253 \text{ K} - \frac{(284.5 \text{ m/s})^2 - (200 \text{ m/s})^2}{2(1.005 \text{ kJ/kg}\cdot\text{K})} \left(\frac{1 \text{ kJ/kg}}{1000 \text{ m}^2/\text{s}^2} \right)$$

$$= \mathbf{232.6 \text{ K}}$$

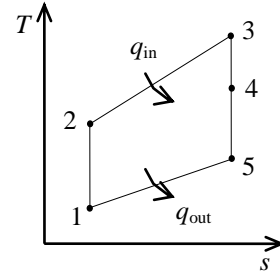

9-132 A pure jet engine operating on an ideal cycle is considered. The velocity at the nozzle exit and the thrust produced are to be determined.

Assumptions 1 Steady operating conditions exist. **2** The air standard assumptions are applicable. **3** Air is an ideal gas with constant specific heats at room temperature. **4** The turbine work output is equal to the compressor work input.

Properties The properties of air at room temperature are $R = 0.287 \text{ kPa}\cdot\text{m}^3/\text{kg}\cdot\text{K}$, $c_p = 1.005 \text{ kJ}/\text{kg}\cdot\text{K}$ and $k = 1.4$ (Table A-2a).

Analysis (a) We assume the aircraft is stationary and the air is moving towards the aircraft at a velocity of $V_1 = 240 \text{ m/s}$. Ideally, the air will leave the diffuser with a negligible velocity ($V_2 \cong 0$).

Diffuser:

$$\begin{aligned} \dot{E}_{\text{in}} - \dot{E}_{\text{out}} &= \Delta \dot{E}_{\text{system}} \overset{\neq 0 \text{ (steady)}}{\longrightarrow} \dot{E}_{\text{in}} = \dot{E}_{\text{out}} \\ h_1 + V_1^2 / 2 &= h_2 + V_2^2 / 2 \longrightarrow 0 = h_2 - h_1 + \frac{V_2^2 \overset{\neq 0}{-} V_1^2}{2} \\ 0 &= c_p (T_2 - T_1) - V_1^2 / 2 \\ T_2 &= T_1 + \frac{V_1^2}{2c_p} = 260 \text{ K} + \frac{(240 \text{ m/s})^2}{(2)(1.005 \text{ kJ}/\text{kg}\cdot\text{K})} \left(\frac{1 \text{ kJ}/\text{kg}}{1000 \text{ m}^2/\text{s}^2} \right) = 288.7 \text{ K} \\ P_2 &= P_1 \left(\frac{T_2}{T_1} \right)^{k/(k-1)} = (45 \text{ kPa}) \left(\frac{288.7 \text{ K}}{260 \text{ K}} \right)^{1.4/0.4} = 64.88 \text{ kPa} \end{aligned}$$

Compressor:

$$\begin{aligned} P_3 &= P_4 = (r_p)(P_2) = (13)(64.88 \text{ kPa}) = 843.5 \text{ kPa} \\ T_3 &= T_2 \left(\frac{P_3}{P_2} \right)^{(k-1)/k} = (288.7 \text{ K})(13)^{0.4/1.4} = 600.7 \text{ K} \end{aligned}$$

Turbine:

$$w_{\text{comp, in}} = w_{\text{turb, out}} \longrightarrow h_3 - h_2 = h_4 - h_5 \longrightarrow c_p (T_3 - T_2) = c_p (T_4 - T_5)$$

$$\text{or } T_5 = T_4 - T_3 + T_2 = 830 - 600.7 + 288.7 = 518.0 \text{ K}$$

Nozzle:

$$T_6 = T_4 \left(\frac{P_6}{P_4} \right)^{(k-1)/k} = (830 \text{ K}) \left(\frac{45 \text{ kPa}}{843.5 \text{ kPa}} \right)^{0.4/1.4} = 359.3 \text{ K}$$

$$\dot{E}_{\text{in}} - \dot{E}_{\text{out}} = \Delta \dot{E}_{\text{system}} \overset{\neq 0 \text{ (steady)}}{\longrightarrow} \dot{E}_{\text{in}} = \dot{E}_{\text{out}}$$

$$h_5 + V_5^2 / 2 = h_6 + V_6^2 / 2$$

$$0 = h_6 - h_5 + \frac{V_6^2 - V_5^2 \overset{\neq 0}{-}}{2} \longrightarrow 0 = c_p (T_6 - T_5) + V_6^2 / 2$$

$$\text{or } V_6 = V_{\text{exit}} = \sqrt{(2)(1.005 \text{ kJ}/\text{kg}\cdot\text{K})(518.0 - 359.3)\text{K} \left(\frac{1000 \text{ m}^2/\text{s}^2}{1 \text{ kJ}/\text{kg}} \right)} = \mathbf{564.8 \text{ m/s}}$$

The mass flow rate through the engine is

$$\begin{aligned} \nu_1 &= \frac{RT}{P} = \frac{(0.287 \text{ kPa}\cdot\text{m}^3)(260 \text{ K})}{45 \text{ kPa}} = 1.658 \text{ m}^3/\text{kg} \\ \dot{m} &= \frac{AV_1}{\nu_1} = \frac{\pi D^2 V_1}{4 \nu_1} = \frac{\pi (1.6 \text{ m})^2}{4} \frac{240 \text{ m/s}}{1.658 \text{ m}^3/\text{kg}} = 291.0 \text{ kg/s} \end{aligned}$$

The thrust force generated is then

$$F = \dot{m}(V_{\text{exit}} - V_{\text{inlet}}) = (291.0 \text{ kg/s})(564.8 - 240) \text{ m/s} \left(\frac{1 \text{ N}}{1 \text{ kg}\cdot\text{m}/\text{s}^2} \right) = \mathbf{94,520 \text{ N}}$$

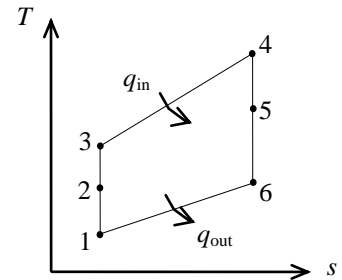

9-133 A turbojet aircraft flying at an altitude of 9150 m is operating on the ideal jet propulsion cycle. The velocity of exhaust gases, the propulsive power developed, and the rate of fuel consumption are to be determined.

Assumptions 1 Steady operating conditions exist. **2** The air standard assumptions are applicable. **3** Air is an ideal gas with constant specific heats at room temperature. **4** Kinetic and potential energies are negligible, except at the diffuser inlet and the nozzle exit. **5** The turbine work output is equal to the compressor work input.

Properties The properties of air at room temperature are $c_p = 1.005 \text{ kJ/kg}\cdot\text{K}$ and $k = 1.4$ (Table A-2a).

Analysis (a) We assume the aircraft is stationary and the air is moving towards the aircraft at a velocity of $V_1 = 280 \text{ m/s}$. Ideally, the air will leave the diffuser with a negligible velocity ($V_2 \cong 0$).

Diffuser:

$$\dot{E}_{\text{in}} - \dot{E}_{\text{out}} = \Delta \dot{E}_{\text{system}}^{\phi_0 \text{ (steady)}} \longrightarrow \dot{E}_{\text{in}} = \dot{E}_{\text{out}}$$

$$h_1 + V_1^2 / 2 = h_2 + V_2^2 / 2 \longrightarrow 0 = h_2 - h_1 + \frac{V_2^2 - V_1^2}{2}$$

$$0 = c_p (T_2 - T_1) - V_1^2 / 2$$

$$T_2 = T_1 + \frac{V_1^2}{2c_p} = 241 \text{ K} + \frac{(280 \text{ m/s})^2}{(2)(1.005 \text{ kJ/kg}\cdot\text{K})} \left(\frac{1 \text{ kJ/kg}}{1000 \text{ m}^2/\text{s}^2} \right) = 280.0 \text{ K}$$

$$P_2 = P_1 \left(\frac{T_2}{T_1} \right)^{k/(k-1)} = (32 \text{ kPa}) \left(\frac{280.0 \text{ K}}{241 \text{ K}} \right)^{1.4/0.4} = 54.10 \text{ kPa}$$

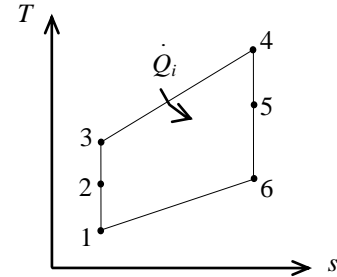

Compressor:

$$P_3 = P_4 = (r_p)(P_2) = (12)(54.10 \text{ kPa}) = 649.2 \text{ kPa}$$

$$T_3 = T_2 \left(\frac{P_3}{P_2} \right)^{(k-1)/k} = (280.0 \text{ K})(12)^{0.4/1.4} = 569.5 \text{ K}$$

Turbine:

$$w_{\text{comp,in}} = w_{\text{turb,out}} \longrightarrow h_3 - h_2 = h_4 - h_5 \longrightarrow c_p (T_3 - T_2) = c_p (T_4 - T_5)$$

or $T_5 = T_4 - T_3 + T_2 = 1100 - 569.5 + 280.0 = 810.5 \text{ K}$

Nozzle:

$$T_6 = T_4 \left(\frac{P_6}{P_4} \right)^{(k-1)/k} = (1100 \text{ K}) \left(\frac{32 \text{ kPa}}{649.2 \text{ kPa}} \right)^{0.4/1.4} = 465.5 \text{ K}$$

$$\dot{E}_{\text{in}} - \dot{E}_{\text{out}} = \Delta \dot{E}_{\text{system}}^{\phi_0 \text{ (steady)}} \longrightarrow \dot{E}_{\text{in}} = \dot{E}_{\text{out}}$$

$$h_5 + V_5^2 / 2 = h_6 + V_6^2 / 2$$

$$0 = h_6 - h_5 + \frac{V_6^2 - V_5^2}{2} \longrightarrow 0 = c_p (T_6 - T_5) + V_6^2 / 2$$

or $V_6 = \sqrt{(2)(1.005 \text{ kJ/kg}\cdot\text{K})(810.5 - 465.5)\text{K} \left(\frac{1000 \text{ m}^2/\text{s}^2}{1 \text{ kJ/kg}} \right)} = \mathbf{832.7 \text{ m/s}}$

(b) $\dot{W}_p = \dot{m}(V_{\text{exit}} - V_{\text{inlet}})V_{\text{aircraft}} = (50 \text{ kg/s})(832.7 - 280)\text{m/s}(280 \text{ m/s}) \left(\frac{1 \text{ kJ/kg}}{1000 \text{ m}^2/\text{s}^2} \right) = \mathbf{7738 \text{ kW}}$

(c) $\dot{Q}_{\text{in}} = \dot{m}(h_4 - h_3) = \dot{m}c_p (T_4 - T_3) = (50 \text{ kg/s})(1.005 \text{ kJ/kg}\cdot\text{K})(1100 - 569.5)\text{K} = 26,657 \text{ kJ/s}$

$$\dot{m}_{\text{fuel}} = \frac{\dot{Q}_{\text{in}}}{\text{HV}} = \frac{26,657 \text{ kJ/s}}{42,700 \text{ kJ/kg}} = \mathbf{0.6243 \text{ kg/s}}$$

9-134 A turbojet aircraft is flying at an altitude of 9150 m. The velocity of exhaust gases, the propulsive power developed, and the rate of fuel consumption are to be determined.

Assumptions 1 Steady operating conditions exist. 2 The air standard assumptions are applicable. 3 Air is an ideal gas with constant specific heats at room temperature. 4 Kinetic and potential energies are negligible, except at the diffuser inlet and the nozzle exit.

Properties The properties of air at room temperature are $c_p = 1.005 \text{ kJ/kg}\cdot\text{K}$ and $k = 1.4$ (Table A-2a).

Analysis (a) For convenience, we assume the aircraft is stationary and the air is moving towards the aircraft at a velocity of $V_1 = 280 \text{ m/s}$. Ideally, the air will leave the diffuser with a negligible velocity ($V_2 \cong 0$).

Diffuser:

$$\dot{E}_{\text{in}} - \dot{E}_{\text{out}} = \Delta \dot{E}_{\text{system}}^{\phi_0} \text{ (steady)}$$

$$\dot{E}_{\text{in}} = \dot{E}_{\text{out}}$$

$$h_1 + V_1^2 / 2 = h_2 + V_2^2 / 2$$

$$0 = h_2 - h_1 + \frac{V_2^2 - V_1^2}{2}$$

$$0 = c_p(T_2 - T_1) - V_1^2 / 2$$

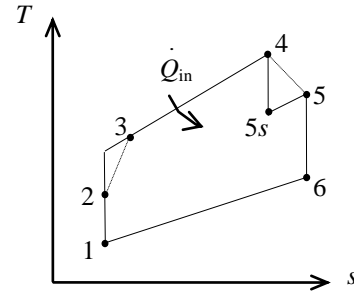

$$T_2 = T_1 + \frac{V_1^2}{2c_p} = 241 \text{ K} + \frac{(280 \text{ m/s})^2}{(2)(1.005 \text{ kJ/kg}\cdot\text{K})} \left(\frac{1 \text{ kJ/kg}}{1000 \text{ m}^2/\text{s}^2} \right) = 280.0 \text{ K}$$

$$P_2 = P_1 \left(\frac{T_2}{T_1} \right)^{k/(k-1)} = (32 \text{ kPa}) \left(\frac{280.0 \text{ K}}{241 \text{ K}} \right)^{1.4/0.4} = 54.10 \text{ kPa}$$

Compressor:

$$P_3 = P_4 = (r_p)(P_2) = (12)(54.10 \text{ kPa}) = 649.2 \text{ kPa}$$

$$T_{3s} = T_2 \left(\frac{P_3}{P_2} \right)^{(k-1)/k} = (280.0 \text{ K})(12)^{0.4/1.4} = 569.5 \text{ K}$$

$$\eta_C = \frac{h_{3s} - h_2}{h_3 - h_2} = \frac{c_p(T_{3s} - T_2)}{c_p(T_3 - T_2)}$$

$$T_3 = T_2 + (T_{3s} - T_2) / \eta_C = 280.0 + (569.5 - 280.0) / (0.80) = 641.9 \text{ K}$$

Turbine:

$$w_{\text{comp, in}} = w_{\text{turb, out}} \longrightarrow h_3 - h_2 = h_4 - h_5 \longrightarrow c_p(T_3 - T_2) = c_p(T_4 - T_5)$$

or,

$$T_5 = T_4 - T_3 + T_2 = 1100 - 641.9 + 280.0 = 738.1 \text{ K}$$

$$\eta_T = \frac{h_4 - h_5}{h_4 - h_{5s}} = \frac{c_p(T_4 - T_5)}{c_p(T_4 - T_{5s})}$$

$$T_{5s} = T_4 - (T_4 - T_5) / \eta_T = 1100 - (1100 - 738.1) / 0.85 = 674.3 \text{ K}$$

$$P_5 = P_4 \left(\frac{T_{5s}}{T_4} \right)^{k/(k-1)} = (649.2 \text{ kPa}) \left(\frac{674.3 \text{ K}}{1100 \text{ K}} \right)^{1.4/0.4} = 117.0 \text{ kPa}$$

Nozzle:

$$T_6 = T_5 \left(\frac{P_6}{P_5} \right)^{(k-1)/k} = (738.1 \text{ K}) \left(\frac{32 \text{ kPa}}{117.0 \text{ kPa}} \right)^{0.4/1.4} = 509.6 \text{ K}$$

$$\dot{E}_{\text{in}} - \dot{E}_{\text{out}} = \Delta \dot{E}_{\text{system}} \quad \phi^0 \text{ (steady)}$$

$$\dot{E}_{\text{in}} = \dot{E}_{\text{out}}$$

$$h_5 + V_5^2 / 2 = h_6 + V_6^2 / 2$$

$$0 = h_6 - h_5 + \frac{V_6^2 - V_5^2}{2} \quad \phi^0$$

$$0 = c_p (T_6 - T_5) + V_6^2 / 2$$

or,

$$V_6 = \sqrt{(2)(1.005 \text{ kJ/kg} \cdot \text{K})(738.1 - 509.6) \text{ K} \left(\frac{1000 \text{ m}^2/\text{s}^2}{1 \text{ kJ/kg}} \right)} = \mathbf{677.8 \text{ m/s}}$$

$$\begin{aligned} (b) \quad \dot{W}_p &= \dot{m}(V_{\text{exit}} - V_{\text{inlet}}) V_{\text{aircraft}} \\ &= (50 \text{ kg/s})(677.8 - 280) \text{ m/s} (280 \text{ m/s}) \left(\frac{1 \text{ kJ/kg}}{1000 \text{ m}^2/\text{s}^2} \right) \\ &= \mathbf{5569 \text{ kW}} \end{aligned}$$

$$(c) \quad \dot{Q}_{\text{in}} = \dot{m}(h_4 - h_3) = \dot{m} c_p (T_4 - T_3) = (50 \text{ kg/s})(1.005 \text{ kJ/kg} \cdot \text{K})(1100 - 641.9) \text{ K} = 23,020 \text{ kJ/s}$$

$$\dot{m}_{\text{fuel}} = \frac{\dot{Q}_{\text{in}}}{\text{HV}} = \frac{23,020 \text{ kJ/s}}{42,700 \text{ kJ/kg}} = \mathbf{0.5391 \text{ kg/s}}$$

9-135 A turbojet aircraft that has a pressure ratio of 9 is stationary on the ground. The force that must be applied on the brakes to hold the plane stationary is to be determined.

Assumptions 1 Steady operating conditions exist. 2 The air standard assumptions are applicable. 3 Air is an ideal gas with variable specific heats. 4 Kinetic and potential energies are negligible, except at the nozzle exit.

Properties The properties of air are given in Table A-17.

Analysis (a) Using variable specific heats for air,

Compressor:

$$T_1 = 290 \text{ K} \longrightarrow h_1 = 290.16 \text{ kJ/kg}$$

$$P_{r_1} = 1.2311$$

$$P_{r_2} = \frac{P_2}{P_1} P_{r_1} = (9)(1.2311) = 11.08 \longrightarrow h_2 = 544.07 \text{ kJ/kg}$$

$$\dot{Q}_{\text{in}} = \dot{m}_{\text{fuel}} \times \text{HV} = (0.5 \text{ kg/s})(42,700 \text{ kJ/kg}) = 21,350 \text{ kJ/s}$$

$$q_{\text{in}} = \frac{\dot{Q}_{\text{in}}}{\dot{m}} = \frac{21,350 \text{ kJ/s}}{20 \text{ kg/s}} = 1067.5 \text{ kJ/kg}$$

$$q_{\text{in}} = h_3 - h_2 \longrightarrow h_3 = h_2 + q_{\text{in}} = 544.07 + 1067.5 = 1611.6 \text{ kJ/kg} \longrightarrow P_{r_3} = 568.5$$

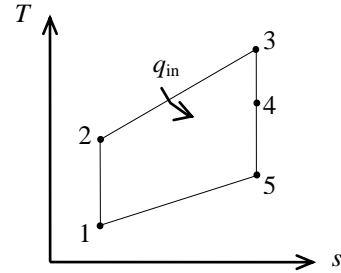

Turbine:

$$w_{\text{comp,in}} = w_{\text{turb,out}} \longrightarrow h_2 - h_1 = h_3 - h_4$$

or

$$h_4 = h_3 - h_2 + h_1 = 1611.6 - 544.07 + 290.16 = 1357.7 \text{ kJ/kg}$$

Nozzle:

$$P_{r_5} = P_{r_3} \left(\frac{P_5}{P_3} \right) = (568.5) \left(\frac{1}{9} \right) = 63.17 \longrightarrow h_5 = 888.56 \text{ kJ/kg}$$

$$\dot{E}_{\text{in}} - \dot{E}_{\text{out}} = \Delta \dot{E}_{\text{system}} \stackrel{\neq 0 \text{ (steady)}}{=} 0$$

$$\dot{E}_{\text{in}} = \dot{E}_{\text{out}}$$

$$h_4 + V_4^2 / 2 = h_5 + V_5^2 / 2$$

$$0 = h_5 - h_4 + \frac{V_5^2 - V_4^2}{2}$$

or

$$V_5 = \sqrt{2(h_4 - h_5)} = \sqrt{(2)(1357.7 - 888.56) \text{ kJ/kg} \left(\frac{1000 \text{ m}^2/\text{s}^2}{1 \text{ kJ/kg}} \right)} = 968.6 \text{ m/s}$$

$$\text{Brake force} = \text{Thrust} = \dot{m}(V_{\text{exit}} - V_{\text{inlet}}) = (20 \text{ kg/s})(968.6 - 0) \text{ m/s} \left(\frac{1 \text{ N}}{1 \text{ kg} \cdot \text{m/s}^2} \right) = \mathbf{19,370 \text{ N}}$$



9-136 Problem 9-135 is reconsidered. The effect of compressor inlet temperature on the force that must be applied to the brakes to hold the plane stationary is to be investigated.

Analysis Using EES, the problem is solved as follows:

```
P_ratio =9
T_1 = 7 [C]
T[1] = T_1+273 "[K]"
P[1]= 95 [kPa]
P[5]=P[1]
Vel[1]=0 [m/s]
V_dot[1] = 18.1 [m^3/s]
HV_fuel = 42700 [kJ/kg]
m_dot_fuel = 0.5 [kg/s]
Eta_c = 1.0
Eta_t = 1.0
Eta_N = 1.0
```

"Inlet conditions"

```
h[1]=ENTHALPY(Air,T=T[1])
s[1]=ENTROPY(Air,T=T[1],P=P[1])
v[1]=volume(Air,T=T[1],P=P[1])
m_dot = V_dot[1]/v[1]
```

"Compressor analysis"

```
s_s[2]=s[1] "For the ideal case the entropies are constant across the compressor"
P_ratio=P[2]/P[1]"Definition of pressure ratio - to find P[2]"
T_s[2]=TEMPERATURE(Air,s=s_s[2],P=P[2]) "T_s[2] is the isentropic value of T[2] at compressor exit"
h_s[2]=ENTHALPY(Air,T=T_s[2])
Eta_c =(h_s[2]-h[1])/(h[2]-h[1]) "Compressor adiabatic efficiency; Eta_c = W_dot_c_ideal/W_dot_c_actual. "
m_dot*h[1] +W_dot_c=m_dot*h[2] "SSSF First Law for the actual compressor, assuming: adiabatic, ke=pe=0"
```

"External heat exchanger analysis"

```
P[3]=P[2]"process 2-3 is SSSF constant pressure"
h[3]=ENTHALPY(Air,T=T[3])
Q_dot_in = m_dot_fuel*HV_fuel
m_dot*h[2] + Q_dot_in= m_dot*h[3]"SSSF First Law for the heat exchanger, assuming W=0, ke=pe=0"
```

"Turbine analysis"

```
s[3]=ENTROPY(Air,T=T[3],P=P[3])
s_s[4]=s[3] "For the ideal case the entropies are constant across the turbine"
{P_ratio= P[3] /P[4]}
T_s[4]=TEMPERATURE(Air,h=h_s[4]) "Ts[4] is the isentropic value of T[4] at turbine exit"
{h_s[4]=ENTHALPY(Air,T=T_s[4])} "Eta_t = W_dot_t /Wts_dot turbine adiabatic efficiency, Wts_dot > W_dot_t"
Eta_t=(h[3]-h[4])/(h[3]-h_s[4])
m_dot*h[3] = W_dot_t + m_dot*h[4] "SSSF First Law for the actual compressor, assuming: adiabatic, ke=pe=0"
T[4]=TEMPERATURE(Air,h=h[4])
P[4]=pressure(Air,s=s_s[4],h=h_s[4])
```

"Cycle analysis"

```
W_dot_net=W_dot_t-W_dot_c"Definition of the net cycle work, kW"
W_dot_net = 0 [kW]
```

"Exit nozzle analysis:"

```
s[4]=entropy('air',T=T[4],P=P[4])
s_s[5]=s[4] "For the ideal case the entropies are constant across the nozzle"
```

```
T_s[5]=TEMPERATURE(Air,s=s_s[5], P=P[5]) "T_s[5] is the isentropic value of T[5] at nozzle exit"
h_s[5]=ENTHALPY(Air,T=T_s[5])
Eta_N=(h[4]-h[5])/(h[4]-h_s[5])
m_dot*h[4] = m_dot*(h_s[5] + Vel_s[5]^2/2*convert(m^2/s^2,kJ/kg))
```

```
m_dot*h[4] = m_dot*(h[5] + Vel[5]^2/2*convert(m^2/s^2,kJ/kg))
T[5]=TEMPERATURE(Air,h=h[5])
s[5]=entropy('air',T=T[5],P=P[5])
```

"Brake Force to hold the aircraft:"

```
Thrust = m_dot*(Vel[5] - Vel[1]) "[N]"
```

```
BrakeForce = Thrust "[N]"
```

"The following state points are determined only to produce a T-s plot"

```
T[2]=temperature('air',h=h[2])
```

```
s[2]=entropy('air',T=T[2],P=P[2])
```

Brake Force [N]	m [kg/s]	T ₃ [K]	T ₁ [C]
21232	23.68	1284	-20
21007	23.22	1307	-15
20788	22.78	1330	-10
20576	22.35	1352	-5
20369	21.94	1375	0
20168	21.55	1398	5
19972	21.17	1420	10
19782	20.8	1443	15
19596	20.45	1466	20
19415	20.1	1488	25
19238	19.77	1510	30

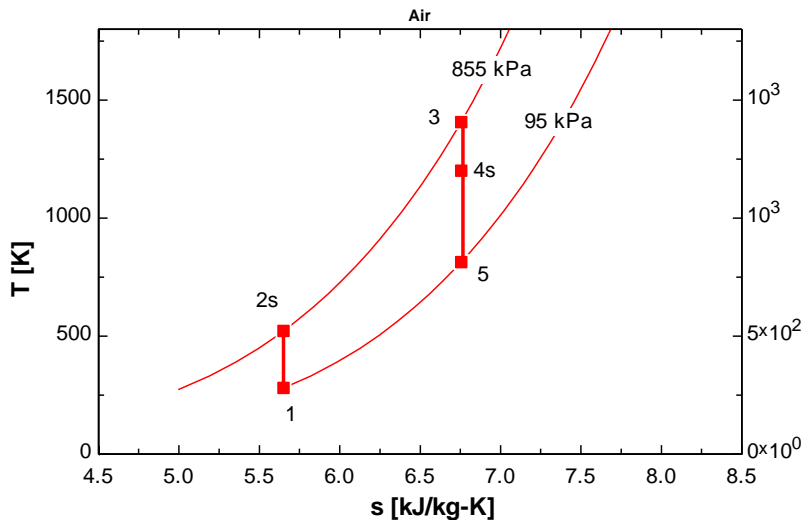
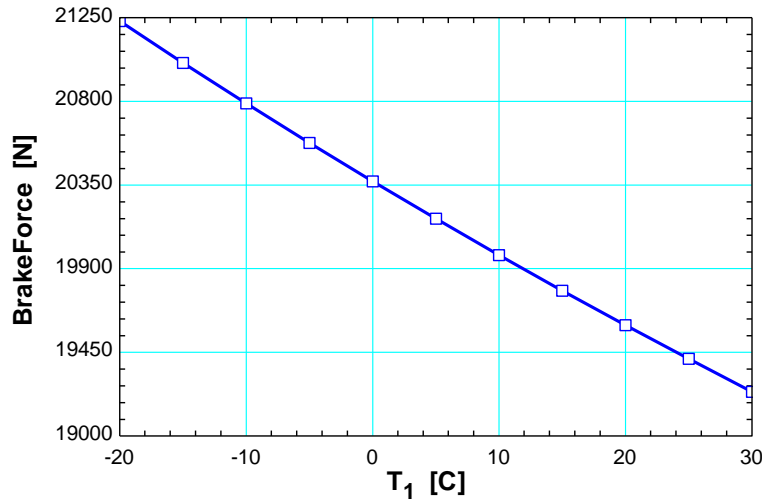

9-137 Air enters a turbojet engine. The thrust produced by this turbojet engine is to be determined.

Assumptions 1 Steady operating conditions exist. 2 The air standard assumptions are applicable. 3 Air is an ideal gas with variable specific heats. 4 Kinetic and potential energies are negligible, except at the diffuser inlet and the nozzle exit.

Properties The properties of air are given in Table A-17.

Analysis We assume the aircraft is stationary and the air is moving towards the aircraft at a velocity of $V_1 = 300$ m/s. Taking the entire engine as our control volume and writing the steady-flow energy balance yield

$$T_1 = 280 \text{ K} \quad \longrightarrow \quad h_1 = 280.13 \text{ kJ/kg}$$

$$T_2 = 700 \text{ K} \quad \longrightarrow \quad h_2 = 713.27 \text{ kJ/kg}$$

$$\dot{E}_{\text{in}} - \dot{E}_{\text{out}} = \Delta \dot{E}_{\text{system}} \stackrel{\approx 0}{\text{(steady)}}$$

$$\dot{E}_{\text{in}} = \dot{E}_{\text{out}}$$

$$\dot{Q}_{\text{in}} + \dot{m}(h_1 + V_1^2 / 2) = \dot{m}(h_2 + V_2^2 / 2)$$

$$\dot{Q}_{\text{in}} = \dot{m} \left(h_2 - h_1 + \frac{V_2^2 - V_1^2}{2} \right)$$

$$15,000 \text{ kJ/s} = (16 \text{ kg/s}) \left[713.27 - 280.13 + \frac{V_2^2 - (300 \text{ m/s})^2}{2} \left(\frac{1 \text{ kJ/kg}}{1000 \text{ m}^2/\text{s}^2} \right) \right]$$

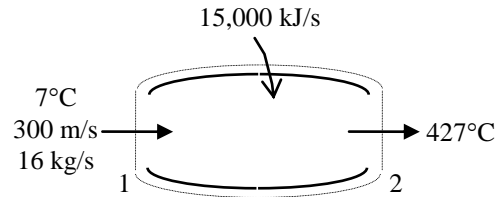

It gives

$$V_2 = 1048 \text{ m/s}$$

Thus,

$$F_p = \dot{m}(V_2 - V_1) = (16 \text{ kg/s})(1048 - 300) \text{ m/s} = \mathbf{11,968 \text{ N}}$$

Second-Law Analysis of Gas Power Cycles

9-138 The total exergy destruction associated with the Otto cycle described in Prob. 9-33 and the exergy at the end of the power stroke are to be determined.

Analysis From Prob. 9-33, $q_{in} = 750$, $q_{out} = 357.62$ kJ/kg, $T_1 = 300$ K, and $T_4 = 774.5$ K.

The total exergy destruction associated with this Otto cycle is determined from

$$x_{\text{destroyed}} = T_0 \left(\frac{q_{\text{out}}}{T_L} - \frac{q_{\text{in}}}{T_H} \right) = (300 \text{ K}) \left(\frac{357.62 \text{ kJ/kg}}{300 \text{ K}} - \frac{750 \text{ kJ/kg}}{2000 \text{ K}} \right) = \mathbf{245.1 \text{ kJ/kg}}$$

Noting that state 4 is identical to the state of the surroundings, the exergy at the end of the power stroke (state 4) is determined from

$$\phi_4 = (u_4 - u_0) - T_0(s_4 - s_0) + P_0(v_4 - v_0)$$

where

$$u_4 - u_0 = u_4 - u_1 = q_{\text{out}} = 357.62 \text{ kJ/kg}$$

$$v_4 - v_0 = v_4 - v_1 = 0$$

$$\begin{aligned} s_4 - s_0 &= s_4 - s_1 = s_4^\circ - s_1^\circ - R \ln \frac{P_4}{P_1} = s_4^\circ - s_1^\circ - R \ln \frac{T_4 v_1}{T_1 v_4} = s_4^\circ - s_1^\circ - R \ln \frac{T_4}{T_1} \\ &= 2.6823 - 1.70203 - (0.287 \text{ kJ/kg} \cdot \text{K}) \ln \frac{774.5 \text{ K}}{300 \text{ K}} = 0.7081 \text{ kJ/kg} \cdot \text{K} \end{aligned}$$

Thus,

$$\phi_4 = (357.62 \text{ kJ/kg}) - (300 \text{ K})(0.7081 \text{ kJ/kg} \cdot \text{K}) + 0 = \mathbf{145.2 \text{ kJ/kg}}$$

9-139 The total exergy destruction associated with the Diesel cycle described in Prob. 9-46 and the exergy at the end of the compression stroke are to be determined.

Analysis From Prob. 9-46, $q_{in} = 1019.7$, $q_{out} = 445.63$ kJ/kg, $T_1 = 300$ K, $v_1 = 0.906$ m³/kg, and $v_2 = v_1 / r = 0.906 / 12 = 0.0566$ m³/kg.

The total exergy destruction associated with this Otto cycle is determined from

$$x_{\text{destroyed}} = T_0 \left(\frac{q_{\text{out}}}{T_L} - \frac{q_{\text{in}}}{T_H} \right) = (300 \text{ K}) \left(\frac{445.63 \text{ kJ/kg}}{300 \text{ K}} - \frac{1019.7 \text{ kJ/kg}}{2000 \text{ K}} \right) = \mathbf{292.7 \text{ kJ/kg}}$$

Noting that state 1 is identical to the state of the surroundings, the exergy at the end of the compression stroke (state 2) is determined from

$$\begin{aligned} \phi_2 &= (u_2 - u_0) - T_0(s_2 - s_0) + P_0(v_2 - v_0) \\ &= (u_2 - u_1) - T_0(s_2 - s_1) + P_0(v_2 - v_1) \\ &= (643.3 - 214.07) - 0 + (95 \text{ kPa})(0.0566 - 0.906) \text{ m}^3/\text{kg} \left(\frac{1 \text{ kJ}}{1 \text{ kPa} \cdot \text{m}^3} \right) \\ &= \mathbf{348.6 \text{ kJ/kg}} \end{aligned}$$

9-140E The exergy destruction associated with the heat rejection process of the Diesel cycle described in Prob. 9-52E and the exergy at the end of the expansion stroke are to be determined.

Analysis From Prob. 9-52E, $q_{\text{out}} = 173.7 \text{ Btu/lbm}$, $T_1 = 580 \text{ R}$, $P_1 = 14.7 \text{ psia}$, and $\nu_4 = \nu_1$.

Also, we obtain temperature and pressure at state 4 as

$$\nu_{r_4} = 9.375 \longrightarrow T_4 = 1531.8 \text{ R}$$

$$\frac{P_4}{P_1} = \frac{T_4}{T_1} \rightarrow P_4 = P_1 \frac{T_4}{T_1} = (14.7 \text{ kPa}) \frac{1531.8 \text{ K}}{580 \text{ K}} = 38.82 \text{ kPa}$$

The entropy change during process 4-1 is

$$\begin{aligned} s_1 - s_4 &= s_1^{\circ} @ 580 \text{ R} - s_4^{\circ} @ 1531.8 \text{ R} - R \ln(P_1 / P_4) \\ &= 0.61793 - 0.85970 - (0.06855) \ln(14.7 / 38.82) \\ &= -0.1752 \text{ Btu/lbm} \cdot \text{R} \end{aligned}$$

Thus,

$$x_{\text{destroyed},41} = T_0 \left(s_1 - s_4 + \frac{q_{R,41}}{T_R} \right) = (540 \text{ R}) \left(-0.1752 \text{ Btu/lbm} \cdot \text{R} + \frac{173.7 \text{ Btu/lbm}}{540 \text{ R}} \right) = \mathbf{79.1 \text{ Btu/lbm}}$$

Noting that state 4 is identical to the state of the surroundings, the exergy at the end of the power stroke (state 4) is determined from

$$\phi_4 = (u_4 - u_0) - T_0(s_4 - s_0) + P_0(\nu_4 - \nu_0)$$

where

$$\begin{aligned} u_4 - u_0 &= u_4 - u_1 = q_{\text{out}} = 173.7 \text{ Btu/lbm} \cdot \text{R} \\ \nu_4 - \nu_0 &= \nu_4 - \nu_1 = 0 \\ s_4 - s_0 &= s_4 - s_1 = 0.1752 \text{ Btu/lbm} \cdot \text{R} \end{aligned}$$

Thus,

$$\phi_4 = (173.7 \text{ Btu/lbm}) - (540 \text{ R})(0.1752 \text{ Btu/lbm} \cdot \text{R}) + 0 = \mathbf{79.1 \text{ Btu/lbm}}$$

Discussion Note that the exergy at state 4 is identical to the exergy destruction for the process 4-1 since state 1 is identical to the dead state, and the entire exergy at state 4 is wasted during process 4-1.

9-141 The exergy loss of each process for an air-standard Stirling cycle described in Prob. 9-74 is to be determined.

Analysis From Prob. 9-74, $q_{in} = 1275 \text{ kJ/kg}$, $q_{out} = 212.5 \text{ kJ/kg}$, $T_1 = T_2 = 1788 \text{ K}$, $T_3 = T_4 = 298 \text{ K}$. The exergy destruction during a process of the cycle is

$$x_{dest} = T_0 s_{gen} = T_0 \left(\Delta s - \frac{q_{in}}{T_{source}} + \frac{q_{out}}{T_{sink}} \right)$$

Application of this equation for each process of the cycle gives

$$\begin{aligned} s_2 - s_1 &= c_v \ln \frac{T_2}{T_1} + R \ln \frac{v_2}{v_1} \\ &= 0 + (0.287 \text{ kJ/kg} \cdot \text{K}) \ln(12) = 0.7132 \text{ kJ/kg} \cdot \text{K} \end{aligned}$$

$$\begin{aligned} x_{dest,1-2} &= T_0 \left(s_2 - s_1 - \frac{q_{in}}{T_{source}} \right) \\ &= (298 \text{ K}) \left(0.7132 \text{ kJ/kg} \cdot \text{K} - \frac{1275 \text{ kJ/kg}}{1788 \text{ K}} \right) = \mathbf{0.034 \text{ kJ/kg} \approx 0} \end{aligned}$$

$$\begin{aligned} s_4 - s_3 &= c_v \ln \frac{T_4}{T_3} + R \ln \frac{v_4}{v_3} \\ &= 0 + (0.287 \text{ kJ/kg} \cdot \text{K}) \ln \left(\frac{1}{12} \right) = -0.7132 \text{ kJ/kg} \cdot \text{K} \end{aligned}$$

$$\begin{aligned} x_{dest,3-4} &= T_0 \left(s_4 - s_3 + \frac{q_{out}}{T_{sink}} \right) \\ &= (298 \text{ K}) \left(-0.7132 \text{ kJ/kg} \cdot \text{K} + \frac{212.5 \text{ kJ/kg}}{298 \text{ K}} \right) = \mathbf{-0.034 \text{ kJ/kg} \approx 0} \end{aligned}$$

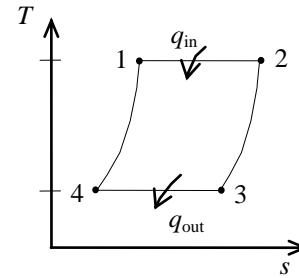

These results are not surprising since Stirling cycle is totally reversible. Exergy destructions are not calculated for processes 2-3 and 4-1 because there is no interaction with the surroundings during these processes to alter the exergy destruction.

9-142 The exergy destruction associated with each of the processes of the Brayton cycle described in Prob. 9-83 is to be determined.

Analysis From Prob. 9-83, $q_{\text{in}} = 698.3 \text{ kJ/kg}$, $q_{\text{out}} = 487.9 \text{ kJ/kg}$, and

$$T_1 = 295 \text{ K} \longrightarrow s_1^\circ = 1.68515 \text{ kJ/kg} \cdot \text{K}$$

$$h_2 = 626.60 \text{ kJ/kg} \longrightarrow s_2^\circ = 2.44117 \text{ kJ/kg} \cdot \text{K}$$

$$T_3 = 1240 \text{ K} \longrightarrow s_3^\circ = 3.21751 \text{ kJ/kg} \cdot \text{K}$$

$$h_4 = 783.04 \text{ kJ/kg} \longrightarrow s_4^\circ = 2.66807 \text{ kJ/kg} \cdot \text{K}$$

Thus,

$$\begin{aligned} x_{\text{destroyed},12} &= T_0 s_{\text{gen},12} = T_0 (s_2 - s_1) = T_0 \left(s_2^\circ - s_1^\circ - R \ln \frac{P_2}{P_1} \right) = \\ &= (295 \text{ K}) (2.44117 - 1.68515 - (0.287 \text{ kJ/kg} \cdot \text{K}) \ln(10)) \\ &= \mathbf{28.08 \text{ kJ/kg}} \end{aligned}$$

$$\begin{aligned} x_{\text{destroyed},23} &= T_0 s_{\text{gen},23} = T_0 \left(s_3 - s_2 + \frac{q_{R,23}}{T_R} \right) = T_0 \left(s_3^\circ - s_2^\circ - R \ln \frac{P_3}{P_2} \overset{\phi_0}{+} \frac{-q_{\text{in}}}{T_H} \right) \\ &= (295 \text{ K}) \left(3.21751 - 2.44117 - \frac{698.3 \text{ kJ/kg}}{1600 \text{ K}} \right) \\ &= \mathbf{100.3 \text{ kJ/kg}} \end{aligned}$$

$$\begin{aligned} x_{\text{destroyed},34} &= T_0 s_{\text{gen},34} = T_0 (s_4 - s_3) = T_0 \left(s_4^\circ - s_3^\circ - R \ln \frac{P_4}{P_3} \right) = \\ &= (295 \text{ K}) (2.66807 - 3.21751 - (0.287 \text{ kJ/kg} \cdot \text{K}) \ln(1/10)) \\ &= \mathbf{32.86 \text{ kJ/kg}} \end{aligned}$$

$$\begin{aligned} x_{\text{destroyed},41} &= T_0 s_{\text{gen},41} = T_0 \left(s_1 - s_4 + \frac{q_{R,41}}{T_R} \right) = T_0 \left(s_1^\circ - s_4^\circ - R \ln \frac{P_1}{P_4} \overset{\phi_0}{+} \frac{q_{\text{out}}}{T_L} \right) \\ &= (295 \text{ K}) \left(1.68515 - 2.66807 + \frac{487.9 \text{ kJ/kg}}{295 \text{ K}} \right) \\ &= \mathbf{197.9 \text{ kJ/kg}} \end{aligned}$$

9-143 Exergy analysis is to be used to answer the question in Prob. 9-86.

Analysis From Prob. 9-86, $T_1 = 288 \text{ K}$, $T_{2s} = 585.8 \text{ K}$, $T_2 = 660.2 \text{ K}$, $T_3 = 873.0 \text{ K}$, $T_{4s} = 429.2 \text{ K}$, $T_4 = 518.0 \text{ K}$, $r_p = 12$. The exergy change of a flow stream between an inlet and exit state is given by

$$\Delta\psi = h_e - h_i - T_0(s_e - s_i)$$

This is also the expression for reversible work. Application of this equation for isentropic and actual compression processes gives

$$\begin{aligned} s_{2s} - s_1 &= c_p \ln \frac{T_{2s}}{T_1} - R \ln \frac{P_2}{P_1} \\ &= (1.005 \text{ kJ/kg} \cdot \text{K}) \ln \frac{585.8 \text{ K}}{288 \text{ K}} - (0.287 \text{ kJ/kg} \cdot \text{K}) \ln(12) \\ &= 0.0003998 \text{ kJ/kg} \cdot \text{K} \end{aligned}$$

$$\begin{aligned} w_{\text{rev},1-2s} &= c_p(T_{2s} - T_1) - T_0(s_{2s} - s_1) \\ &= (1.005 \text{ kJ/kg} \cdot \text{K})(585.8 - 288) \text{ K} - (288 \text{ K})(0.0003998 \text{ kJ/kg} \cdot \text{K}) = 299.2 \text{ kJ/kg} \end{aligned}$$

$$\begin{aligned} s_2 - s_1 &= c_p \ln \frac{T_2}{T_1} - R \ln \frac{P_2}{P_1} \\ &= (1.005 \text{ kJ/kg} \cdot \text{K}) \ln \frac{660.2 \text{ K}}{288 \text{ K}} - (0.287 \text{ kJ/kg} \cdot \text{K}) \ln(12) = 0.1206 \text{ kJ/kg} \cdot \text{K} \end{aligned}$$

$$\begin{aligned} w_{\text{rev},1-2} &= c_p(T_2 - T_1) - T_0(s_2 - s_1) \\ &= (1.005 \text{ kJ/kg} \cdot \text{K})(660.2 - 288) \text{ K} - (288 \text{ K})(0.1206 \text{ kJ/kg} \cdot \text{K}) = 339.3 \text{ kJ/kg} \end{aligned}$$

The irreversibilities therefore increase the minimum work that must be supplied to the compressor by

$$\Delta w_{\text{rev},C} = w_{\text{rev},1-2} - w_{\text{rev},1-2s} = 339.3 - 299.2 = \mathbf{40.2 \text{ kJ/kg}}$$

Repeating the calculations for the turbine,

$$\begin{aligned} s_3 - s_{4s} &= c_p \ln \frac{T_3}{T_{4s}} - R \ln \frac{P_3}{P_4} \\ &= (1.005 \text{ kJ/kg} \cdot \text{K}) \ln \frac{873 \text{ K}}{429.2 \text{ K}} - (0.287 \text{ kJ/kg} \cdot \text{K}) \ln(12) = 0.0003944 \text{ kJ/kg} \cdot \text{K} \end{aligned}$$

$$\begin{aligned} w_{\text{rev},3-4s} &= c_p(T_3 - T_{4s}) - T_0(s_3 - s_{4s}) \\ &= (1.005 \text{ kJ/kg} \cdot \text{K})(873 - 429.2) \text{ K} - (288 \text{ K})(0.0003944 \text{ kJ/kg} \cdot \text{K}) = 445.9 \text{ kJ/kg} \end{aligned}$$

$$\begin{aligned} s_3 - s_4 &= c_p \ln \frac{T_3}{T_4} - R \ln \frac{P_3}{P_4} \\ &= (1.005 \text{ kJ/kg} \cdot \text{K}) \ln \frac{873 \text{ K}}{518.0 \text{ K}} - (0.287 \text{ kJ/kg} \cdot \text{K}) \ln(12) = -0.1885 \text{ kJ/kg} \cdot \text{K} \end{aligned}$$

$$\begin{aligned} w_{\text{rev},3-4} &= c_p(T_3 - T_4) - T_0(s_3 - s_4) \\ &= (1.005 \text{ kJ/kg} \cdot \text{K})(873 - 518.0) \text{ K} - (288 \text{ K})(-0.1885 \text{ kJ/kg} \cdot \text{K}) = 411.1 \text{ kJ/kg} \end{aligned}$$

$$\Delta w_{\text{rev},T} = w_{\text{rev},3-4s} - w_{\text{rev},3-4} = 445.9 - 411.1 = \mathbf{34.8 \text{ kJ/kg}}$$

Hence, it is clear that the compressor is a little more sensitive to the irreversibilities than the turbine.

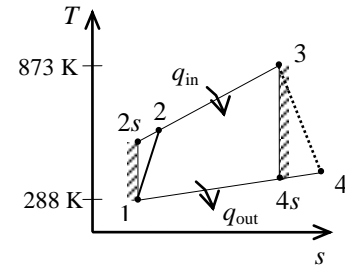

9-144 The total exergy destruction associated with the Brayton cycle described in Prob. 9-107 and the exergy at the exhaust gases at the turbine exit are to be determined.

Properties The gas constant of air is $R = 0.287 \text{ kJ/kg}\cdot\text{K}$ (Table A-1).

Analysis From Prob. 9-107, $q_{in} = 480.82$, $q_{out} = 372.73 \text{ kJ/kg}$, and

$$T_1 = 310 \text{ K} \longrightarrow s_1^\circ = 1.73498 \text{ kJ/kg}\cdot\text{K}$$

$$h_2 = 618.26 \text{ kJ/kg} \longrightarrow s_2^\circ = 2.42763 \text{ kJ/kg}\cdot\text{K}$$

$$T_3 = 1150 \text{ K} \longrightarrow s_3^\circ = 3.12900 \text{ kJ/kg}\cdot\text{K}$$

$$h_4 = 803.14 \text{ kJ/kg} \longrightarrow s_4^\circ = 2.69407 \text{ kJ/kg}\cdot\text{K}$$

$$h_5 = 738.43 \text{ kJ/kg} \longrightarrow s_5^\circ = 2.60815 \text{ kJ/kg}\cdot\text{K}$$

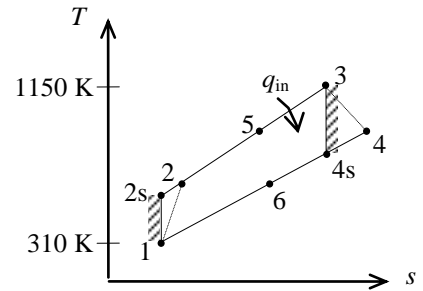

and, from an energy balance on the heat exchanger,

$$h_5 - h_2 = h_4 - h_6 \longrightarrow h_6 = 803.14 - (738.43 - 618.26) = 682.97 \text{ kJ/kg}$$

$$\longrightarrow s_6^\circ = 2.52861 \text{ kJ/kg}\cdot\text{K}$$

Thus,

$$\begin{aligned} x_{\text{destroyed},12} &= T_0 s_{\text{gen},12} = T_0 (s_2 - s_1) = T_0 \left(s_2^\circ - s_1^\circ - R \ln \frac{P_2}{P_1} \right) \\ &= (290 \text{ K}) (2.42763 - 1.73498 - (0.287 \text{ kJ/kg}\cdot\text{K}) \ln(7)) = \mathbf{38.91 \text{ kJ/kg}} \end{aligned}$$

$$\begin{aligned} x_{\text{destroyed},34} &= T_0 s_{\text{gen},34} = T_0 (s_4 - s_3) = T_0 \left(s_4^\circ - s_3^\circ - R \ln \frac{P_4}{P_3} \right) \\ &= (290 \text{ K}) (2.69407 - 3.12900 - (0.287 \text{ kJ/kg}\cdot\text{K}) \ln(1/7)) = \mathbf{35.83 \text{ kJ/kg}} \end{aligned}$$

$$\begin{aligned} x_{\text{destroyed,regen}} &= T_0 s_{\text{gen,regen}} = T_0 [(s_5 - s_2) + (s_6 - s_4)] = T_0 [(s_5^\circ - s_2^\circ) + (s_6^\circ - s_4^\circ)] \\ &= (290 \text{ K}) (2.60815 - 2.42763 + 2.52861 - 2.69407) = \mathbf{4.37 \text{ kJ/kg}} \end{aligned}$$

$$\begin{aligned} x_{\text{destroyed},53} &= T_0 s_{\text{gen},53} = T_0 \left(s_3 - s_5 - \frac{q_{R,53}}{T_R} \right) = T_0 \left(s_3^\circ - s_5^\circ - R \ln \frac{P_3}{P_5} \phi^0 - \frac{q_{in}}{T_H} \right) \\ &= (290 \text{ K}) \left(3.12900 - 2.60815 - \frac{480.82 \text{ kJ/kg}}{1500 \text{ K}} \right) = \mathbf{58.09 \text{ kJ/kg}} \end{aligned}$$

$$\begin{aligned} x_{\text{destroyed},61} &= T_0 s_{\text{gen},61} = T_0 \left(s_1 - s_6 + \frac{q_{R,61}}{T_R} \right) = T_0 \left(s_1^\circ - s_6^\circ - R \ln \frac{P_1}{P_6} \phi^0 + \frac{q_{out}}{T_L} \right) \\ &= (290 \text{ K}) \left(1.73498 - 2.52861 + \frac{372.73 \text{ kJ/kg}}{290 \text{ K}} \right) = \mathbf{142.6 \text{ kJ/kg}} \end{aligned}$$

Noting that $h_0 = h_{@ 290 \text{ K}} = 290.16 \text{ kJ/kg}$ and $T_0 = 290 \text{ K} \longrightarrow s_1^\circ = 1.66802 \text{ kJ/kg}\cdot\text{K}$, the stream exergy at the exit of the regenerator (state 6) is determined from

$$\phi_6 = (h_6 - h_0) - T_0 (s_6 - s_0) + \frac{V_6^2}{2} \phi^0 + gz_6 \phi^0$$

where

$$s_6 - s_0 = s_6 - s_1 = s_6^\circ - s_1^\circ - R \ln \frac{P_6}{P_1} \phi^0 = 2.52861 - 1.66802 = 0.86059 \text{ kJ/kg}\cdot\text{K}$$

Thus,

$$\phi_6 = 682.97 - 290.16 - (290 \text{ K})(0.86059 \text{ kJ/kg}\cdot\text{K}) = \mathbf{143.2 \text{ kJ/kg}}$$



9-145 Prob. 9-144 is reconsidered. The effect of the cycle pressure on the total irreversibility for the cycle and the exergy of the exhaust gas leaving the regenerator is to be investigated.

Analysis Using EES, the problem is solved as follows:

"Given"

```
T[1]=310 [K]
P[1]=100 [kPa]
Ratio_P=7
P[2]=Ratio_P*P[1]
T[3]=1150 [K]
eta_C=0.75
eta_T=0.82
epsilon=0.65
T_H=1500 [K]
T0=290 [K]
P0=100 [kPa]
```

"Analysis for Problem 9-144"

```
q_in=h[3]-h[5]
q_out=h[6]-h[1]
h[5]-h[2]=h[4]-h[6]
s[2]=entropy(Fluid$, P=P[2], h=h[2])
s[4]=entropy(Fluid$, h=h[4], P=P[4])
s[5]=entropy(Fluid$, h=h[5], P=P[5])
P[5]=P[2]
s[6]=entropy(Fluid$, h=h[6], P=P[6])
P[6]=P[1]
h[0]=enthalpy(Fluid$, T=T0)
s[0]=entropy(Fluid$, T=T0, P=P0)
x_destroyed_12=T0*(s[2]-s[1])
x_destroyed_34=T0*(s[4]-s[3])
x_destroyed_regen=T0*(s[5]-s[2]+s[6]-s[4])
x_destroyed_53=T0*(s[3]-s[5]-q_in/T_H)
x_destroyed_61=T0*(s[1]-s[6]+q_out/T0)
x_total=x_destroyed_12+x_destroyed_34+x_destroyed_regen+x_destroyed_53+x_destroyed_61
x6=h[6]-h[0]-T0*(s[6]-s[0]) "since state 0 and state 1 are identical"
```

"Analysis for Problem 9-107"

```
Fluid$='air'
"(a)"
h[1]=enthalpy(Fluid$, T=T[1])
s[1]=entropy(Fluid$, T=T[1], P=P[1])
s_s[2]=s[1] "isentropic compression"
h_s[2]=enthalpy(Fluid$, P=P[2], s=s_s[2])
eta_C=(h_s[2]-h[1])/(h[2]-h[1])
h[3]=enthalpy(Fluid$, T=T[3])
s[3]=entropy(Fluid$, T=T[3], P=P[3])
P[3]=P[2]
s_s[4]=s[3] "isentropic expansion"
h_s[4]=enthalpy(Fluid$, P=P[4], s=s_s[4])
P[4]=P[1]
eta_T=(h[3]-h[4])/(h[3]-h_s[4])
q_regen=epsilon*(h[4]-h[2])
```

"(b)"

```
w_C_in=(h[2]-h[1])
w_T_out=h[3]-h[4]
w_net_out=w_T_out-w_C_in
```

$$q_{in} = (h[3] - h[2]) - q_{regen}$$

$$\eta_{th} = w_{net_out} / q_{in}$$

Ratio_P	x_{total} [kJ/kg]	x_6 [kJ/kg]
6	270.1	137.2
7	280	143.5
8	289.9	149.6
9	299.5	155.5
10	308.8	161.1
11	317.8	166.6
12	326.6	171.9
13	335.1	177.1
14	343.3	182.1

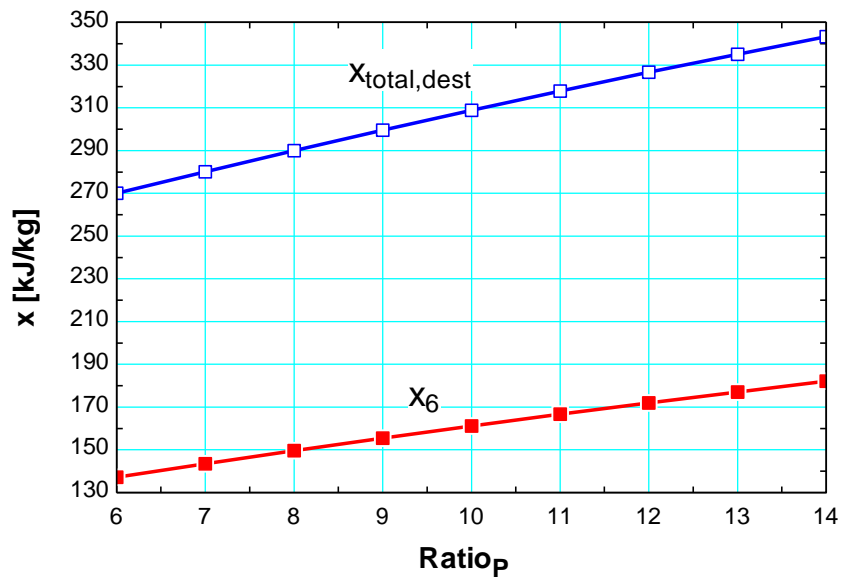

9-146 The exergy destruction associated with each of the processes of the Brayton cycle described in Prob. 9-109 and the exergy at the end of the exhaust gases at the exit of the regenerator are to be determined.

Properties The gas constant of air is $R = 0.287 \text{ kJ/kg} \cdot \text{K}$ (Table A-1).

Analysis From Prob. 9-109, $q_{\text{in}} = 662.88 \text{ kJ/kg}$, $q_{\text{out}} = 397.80 \text{ kJ/kg}$, and

$$T_1 = 310 \text{ K} \longrightarrow s_1^\circ = 1.73498 \text{ kJ/kg} \cdot \text{K}$$

$$h_2 = 659.84 \text{ kJ/kg} \longrightarrow s_2^\circ = 2.49364 \text{ kJ/kg} \cdot \text{K}$$

$$T_3 = 1400 \text{ K} \longrightarrow s_3^\circ = 3.36200 \text{ kJ/kg} \cdot \text{K}$$

$$h_4 = 900.74 \text{ kJ/kg} \longrightarrow s_4^\circ = 2.81216 \text{ kJ/kg} \cdot \text{K}$$

$$h_5 = 852.54 \text{ kJ/kg} \longrightarrow s_5^\circ = 2.75537 \text{ kJ/kg} \cdot \text{K}$$

$$h_6 = 708.04 \text{ kJ/kg} \longrightarrow s_6^\circ = 2.56525 \text{ kJ/kg} \cdot \text{K}$$

where

$$q_{\text{out}} = q_{\text{in}} - w_{\text{net}} = 662.88 - 265.08 = 397.80 \text{ kJ/kg}$$

$$h_6 = h_1 + q_{\text{out}} = 310.24 + 397.80 = 708.04 \text{ kJ/kg}$$

$$h_5 - h_2 = h_4 - h_6 \rightarrow h_5 - 659.84 = 900.74 - 708.04 \rightarrow h_5 = 852.54$$

Thus,

$$\begin{aligned} x_{\text{destroyed},12} &= T_0 s_{\text{gen},12} = T_0 (s_2 - s_1) = T_0 \left(s_2^\circ - s_1^\circ - R \ln \frac{P_2}{P_1} \right) \\ &= (300 \text{ K}) (2.49364 - 1.73498 - (0.287 \text{ kJ/kg} \cdot \text{K}) \ln(9)) = \mathbf{38.42 \text{ kJ/kg}} \end{aligned}$$

$$\begin{aligned} x_{\text{destroyed},34} &= T_0 s_{\text{gen},34} = T_0 (s_4 - s_3) = T_0 \left(s_4^\circ - s_3^\circ - R \ln \frac{P_4}{P_3} \right) \\ &= (300 \text{ K}) (2.81216 - 3.36200 - (0.287 \text{ kJ/kg} \cdot \text{K}) \ln(1/9)) = \mathbf{24.23 \text{ kJ/kg}} \end{aligned}$$

$$\begin{aligned} x_{\text{destroyed,regen}} &= T_0 s_{\text{gen,regen}} = T_0 [(s_5 - s_2) + (s_6 - s_4)] = T_0 [(s_5^\circ - s_2^\circ) + (s_6^\circ - s_4^\circ)] \\ &= (300 \text{ K}) (2.75537 - 2.49364 + 2.56525 - 2.81216) = \mathbf{4.47 \text{ kJ/kg}} \end{aligned}$$

$$\begin{aligned} x_{\text{destroyed},53} &= T_0 s_{\text{gen},53} = T_0 \left(s_3 - s_5 - \frac{q_{R,53}}{T_R} \right) = T_0 \left(s_3^\circ - s_5^\circ - R \ln \frac{P_3}{P_5} \frac{\phi_0}{T_H} - \frac{q_{\text{in}}}{T_H} \right) \\ &= (300 \text{ K}) \left(3.36200 - 2.75537 - \frac{662.88 \text{ kJ/kg}}{1260 \text{ K}} \right) = \mathbf{24.16 \text{ kJ/kg}} \end{aligned}$$

$$\begin{aligned} x_{\text{destroyed},61} &= T_0 s_{\text{gen},61} = T_0 \left(s_1 - s_6 + \frac{q_{R,61}}{T_R} \right) = T_0 \left(s_1^\circ - s_6^\circ - R \ln \frac{P_1}{P_6} \frac{\phi_0}{T_L} + \frac{q_{\text{out}}}{T_L} \right) \\ &= (300 \text{ K}) \left(1.73498 - 2.56525 + \frac{397.80 \text{ kJ/kg}}{300 \text{ K}} \right) = \mathbf{148.7 \text{ kJ/kg}} \end{aligned}$$

Noting that at $T_0 = 300 \text{ K} \rightarrow h_0 = h_{@ 300 \text{ K}} = 300.19 \text{ kJ/kg}$ and $s_0^\circ = 1.70203 \text{ kJ/kg} \cdot \text{K}$

the stream exergy at the exit of the regenerator (state 6) is determined from

$$\phi_6 = (h_6 - h_0) - T_0 (s_6 - s_0) + \frac{V_6^2}{2} \frac{\phi_0}{T_0} + g z_6 \frac{\phi_0}{T_0}$$

$$\text{where } s_6 - s_0 = s_6^\circ - s_0^\circ - R \ln \frac{P_6}{P_1} \frac{\phi_0}{T_0} = 2.56525 - 1.70203 = 0.86322 \text{ kJ/kg} \cdot \text{K}$$

$$\text{Thus, } \phi_6 = 708.04 - 300.19 - (300 \text{ K})(0.86322 \text{ kJ/kg} \cdot \text{K}) = \mathbf{148.9 \text{ kJ/kg}}$$

9-147 The exergy loss of each process for a regenerative Brayton cycle with three stages of reheating and intercooling described in Prob. 9-125 is to be determined.

Analysis From Prob. 9-125,

$$r_p = 4, \quad q_{in,7-8} = q_{in,9-10} = q_{in,11-12} = 300 \text{ kJ/kg},$$

$$q_{out,14-1} = 222.0 \text{ kJ/kg}, \quad q_{out,2-3} = q_{out,4-5} = 141.6 \text{ kJ/kg},$$

$$T_1 = T_3 = T_5 = 290 \text{ K}, \quad T_2 = T_4 = T_6 = 430.9 \text{ K}$$

$$T_7 = 499.2 \text{ K}, \quad T_8 = 797.7 \text{ K}, \quad T_9 = 536.8 \text{ K}$$

$$T_{10} = 835.3 \text{ K}, \quad T_{11} = 562.1 \text{ K}, \quad T_{12} = 860.6 \text{ K},$$

$$T_{13} = 579.2 \text{ K}, \quad T_{14} = 510.9 \text{ K}$$

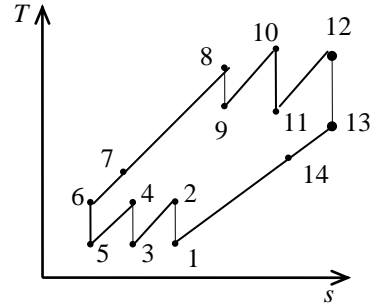

The exergy destruction during a process of a stream from an inlet state to exit state is given by

$$x_{dest} = T_0 s_{gen} = T_0 \left(s_e - s_i - \frac{q_{in}}{T_{source}} + \frac{q_{out}}{T_{sink}} \right)$$

Application of this equation for each process of the cycle gives

$$\begin{aligned} x_{dest,1-2} = x_{dest,3-4} = x_{dest,5-6} &= T_0 \left(c_p \ln \frac{T_2}{T_1} - R \ln \frac{P_2}{P_1} \right) \\ &= (290) \left[(1.005) \ln \frac{430.9}{290} - (0.287) \ln(4) \right] = \mathbf{0.03 \text{ kJ/kg} \approx 0} \end{aligned}$$

$$x_{dest,7-8} = T_0 \left(c_p \ln \frac{T_8}{T_7} - R \ln \frac{P_8}{P_7} - \frac{q_{in,7-8}}{T_{source}} \right) = (290) \left[(1.005) \ln \frac{797.7}{499.2} - 0 - \frac{300}{860.6} \right] = \mathbf{35.5 \text{ kJ/kg}}$$

$$x_{dest,9-10} = T_0 \left(c_p \ln \frac{T_{10}}{T_9} - R \ln \frac{P_{10}}{P_9} - \frac{q_{in,9-10}}{T_{source}} \right) = (290) \left[(1.005) \ln \frac{835.3}{536.8} - 0 - \frac{300}{860.6} \right] = \mathbf{27.8 \text{ kJ/kg}}$$

$$x_{dest,11-12} = T_0 \left(c_p \ln \frac{T_{12}}{T_{11}} - R \ln \frac{P_{12}}{P_{11}} - \frac{q_{in,11-12}}{T_{source}} \right) = (290) \left[(1.005) \ln \frac{860.6}{562.1} - 0 - \frac{300}{860.6} \right] = \mathbf{23.1 \text{ kJ/kg}}$$

$$x_{dest,8-9} = T_0 \left(c_p \ln \frac{T_9}{T_8} - R \ln \frac{P_9}{P_8} \right) = (290) \left[(1.005) \ln \frac{536.8}{797.7} - (0.287) \ln \left(\frac{1}{4} \right) \right] = \mathbf{-0.06 \text{ kJ/kg} \approx 0}$$

$$x_{dest,10-11} = T_0 \left(c_p \ln \frac{T_{11}}{T_{10}} - R \ln \frac{P_{11}}{P_{10}} \right) = (290) \left[(1.005) \ln \frac{562.1}{835.3} - (0.287) \ln \left(\frac{1}{4} \right) \right] = \mathbf{-0.07 \text{ kJ/kg} \approx 0}$$

$$x_{dest,12-13} = T_0 \left(c_p \ln \frac{T_{13}}{T_{12}} - R \ln \frac{P_{13}}{P_{12}} \right) = (290) \left[(1.005) \ln \frac{579.2}{860.6} - (0.287) \ln \left(\frac{1}{4} \right) \right] = \mathbf{-0.03 \text{ kJ/kg} \approx 0}$$

$$x_{dest,14-1} = T_0 \left(c_p \ln \frac{T_1}{T_{14}} - R \ln \frac{P_1}{P_{14}} + \frac{q_{out,14-1}}{T_{sink}} \right) = (290) \left[(1.005) \ln \frac{290}{510.9} - 0 + \frac{222.0}{290} \right] = \mathbf{57.0 \text{ kJ/kg}}$$

$$x_{dest,2-3} = x_{dest,4-5} = T_0 \left(c_p \ln \frac{T_3}{T_2} - R \ln \frac{P_3}{P_2} + \frac{q_{out,2-3}}{T_{sink}} \right) = (290) \left[(1.005) \ln \frac{290}{430.9} - 0 + \frac{141.6}{290} \right] = \mathbf{26.2 \text{ kJ/kg}}$$

$$\begin{aligned} x_{dest,regen} &= T_0 (\Delta s_{6-7} + \Delta s_{13-14}) = T_0 \left(c_p \ln \frac{T_7}{T_6} + c_p \ln \frac{T_{14}}{T_{13}} \right) \\ &= (290) \left[(1.005) \ln \frac{499.2}{430.9} + (1.005) \ln \frac{510.9}{579.2} \right] = \mathbf{6.30 \text{ kJ/kg}} \end{aligned}$$

9-148 A gas-turbine plant operates on the regenerative Brayton cycle. The isentropic efficiency of the compressor, the effectiveness of the regenerator, the air-fuel ratio in the combustion chamber, the net power output, the back work ratio, the thermal efficiency, the second law efficiency, the exergy efficiencies of the compressor, the turbine, and the regenerator, and the rate of the exergy of the combustion gases at the regenerator exit are to be determined.

Assumptions 1 The air-standard assumptions are applicable. **2** Kinetic and potential energy changes are negligible. **3** Air is an ideal gas with constant specific heats.

Properties The properties of air at $500^\circ\text{C} = 773\text{ K}$ are $c_p = 1.093\text{ kJ/kg}\cdot\text{K}$, $c_v = 0.806\text{ kJ/kg}\cdot\text{K}$, $R = 0.287\text{ kJ/kg}\cdot\text{K}$, and $k = 1.357$ (Table A-2b).

Analysis (a) For the compressor and the turbine:

$$T_{2s} = T_1 \left(\frac{P_2}{P_1} \right)^{\frac{k-1}{k}} = (303\text{ K}) \left(\frac{700\text{ kPa}}{100\text{ kPa}} \right)^{\frac{1.357-1}{1.357}} = 505.6\text{ K}$$

$$\eta_c = \frac{T_{2s} - T_1}{T_2 - T_1} = \frac{(505.6 - 303)\text{ K}}{(533 - 303)\text{ K}} = \mathbf{0.881}$$

$$T_{4s} = T_3 \left(\frac{P_4}{P_3} \right)^{\frac{k-1}{k}} = (1144\text{ K}) \left(\frac{100\text{ kPa}}{700\text{ kPa}} \right)^{\frac{1.357-1}{1.357}} = 685.6\text{ K}$$

$$\eta_T = \frac{T_3 - T_4}{T_3 - T_{4s}} \rightarrow 0.85 = \frac{(1144 - T_4)\text{ K}}{(1144 - 685.6)\text{ K}} \rightarrow T_4 = 754.4\text{ K}$$

(b) The effectiveness of the regenerator is

$$\varepsilon_{\text{regen}} = \frac{T_5 - T_2}{T_4 - T_2} = \frac{(673 - 533)\text{ K}}{(754.4 - 533)\text{ K}} = \mathbf{0.632}$$

(c) The fuel rate and air-fuel ratio are

$$\dot{Q}_{\text{in}} = \dot{m}_f q_{\text{HV}} \eta_c = (\dot{m}_f + \dot{m}_a) c_p (T_3 - T_5)$$

$$\dot{m}_f (42,000\text{ kJ/kg})(0.97) = (\dot{m}_f + 12.6)(1.093\text{ kJ/kg}\cdot\text{K})(1144 - 673)\text{ K} \rightarrow \dot{m}_f = 0.1613\text{ kg/s}$$

$$\text{AF} = \frac{\dot{m}_a}{\dot{m}_f} = \frac{12.6}{0.1613} = \mathbf{78.14}$$

Also,

$$\dot{m} = \dot{m}_a + \dot{m}_f = 12.6 + 0.1613 = 12.76\text{ kg/s}$$

$$\dot{Q}_{\text{in}} = \dot{m}_f q_{\text{HV}} \eta_c = (0.1613\text{ kg/s})(42,000\text{ kJ/kg})(0.97) = 6570\text{ kW}$$

(d) The net power and the back work ratio are

$$\dot{W}_{\text{C,in}} = \dot{m}_a c_p (T_2 - T_1) = (12.6\text{ kg/s})(1.093\text{ kJ/kg}\cdot\text{K})(533 - 303)\text{ K} = 3168\text{ kW}$$

$$\dot{W}_{\text{T,out}} = \dot{m} c_p (T_3 - T_4) = (12.76\text{ kg/s})(1.093\text{ kJ/kg}\cdot\text{K})(1144 - 754.4)\text{ K} = 5434\text{ kW}$$

$$\dot{W}_{\text{net}} = \dot{W}_{\text{T,out}} - \dot{W}_{\text{C,in}} = 5434 - 3168 = \mathbf{2267\text{ kW}}$$

$$r_{\text{bw}} = \frac{\dot{W}_{\text{C,in}}}{\dot{W}_{\text{T,out}}} = \frac{3168\text{ kW}}{5434\text{ kW}} = \mathbf{0.583}$$

(e) The thermal efficiency is

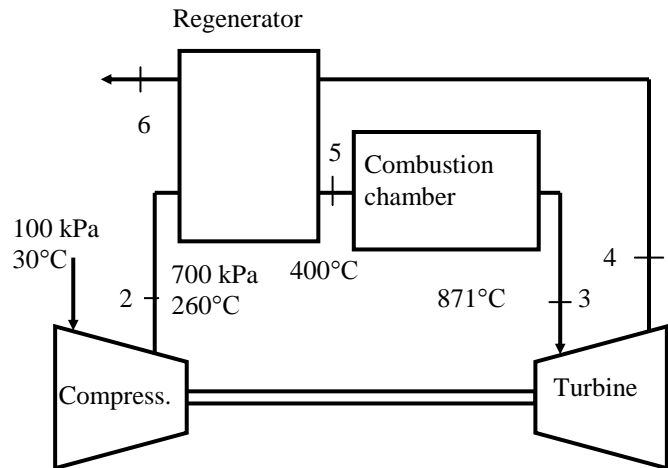

$$\eta_{th} = \frac{\dot{W}_{net}}{\dot{Q}_{in}} = \frac{2267 \text{ kW}}{6570 \text{ kW}} = \mathbf{0.345}$$

(f) The second-law efficiency of the cycle is defined as the ratio of actual thermal efficiency to the maximum possible thermal efficiency (Carnot efficiency). The maximum temperature for the cycle can be taken to be the turbine inlet temperature. That is,

$$\eta_{max} = 1 - \frac{T_1}{T_3} = 1 - \frac{303 \text{ K}}{1144 \text{ K}} = 0.735$$

and

$$\eta_{II} = \frac{\eta_{th}}{\eta_{max}} = \frac{0.345}{0.735} = \mathbf{0.469}$$

(g) The exergy efficiency for the compressor is defined as the ratio of stream exergy difference between the inlet and exit of the compressor to the actual power input:

$$\begin{aligned} \Delta \dot{X}_C &= \dot{m}_a [h_2 - h_1 - T_0 (s_2 - s_1)] = \dot{m}_a \left\{ c_p (T_2 - T_1) - T_0 \left[c_p \ln \frac{T_2}{T_1} - R \ln \frac{P_2}{P_1} \right] \right\} \\ &= (12.6) \left\{ (1.093)(533 - 303) - (303) \left[(1.093) \ln \left(\frac{533}{303} \right) - 0.287 \ln \left(\frac{700}{100} \right) \right] \right\} \\ &= 2943 \text{ kW} \\ \eta_{II,C} &= \frac{\Delta \dot{X}_C}{\dot{W}_{C,in}} = \frac{2943 \text{ kW}}{3168 \text{ kW}} = \mathbf{0.929} \end{aligned}$$

The exergy efficiency for the turbine is defined as the ratio of actual turbine power to the stream exergy difference between the inlet and exit of the turbine:

$$\begin{aligned} \Delta \dot{X}_T &= \dot{m} \left\{ c_p (T_3 - T_4) - T_0 \left[c_p \ln \frac{T_3}{T_4} - R \ln \frac{P_3}{P_4} \right] \right\} \\ &= (12.76) \left\{ (1.093)(1144 - 754.4) - (303) \left[(1.093) \ln \left(\frac{1144}{754.4} \right) - 0.287 \ln \left(\frac{700}{100} \right) \right] \right\} \\ &= 5834 \text{ kW} \\ \eta_{II,T} &= \frac{\dot{W}_{T,in}}{\Delta \dot{X}_T} = \frac{5434 \text{ kW}}{5834 \text{ kW}} = \mathbf{0.932} \end{aligned}$$

An energy balance on the regenerator gives

$$\begin{aligned} \dot{m}_a c_p (T_5 - T_2) &= \dot{m} c_p (T_4 - T_6) \\ (12.6)(1.093)(673 - 533) &= (12.76)(1.093)(754.4 - T_6) \longrightarrow T_6 = 616.2 \text{ K} \end{aligned}$$

The exergy efficiency for the regenerator is defined as the ratio of the exergy increase of the cold fluid to the exergy decrease of the hot fluid:

$$\begin{aligned} \Delta \dot{X}_{regen,hot} &= \dot{m} \left\{ c_p (T_4 - T_6) - T_0 \left[c_p \ln \frac{T_4}{T_6} - 0 \right] \right\} \\ &= (12.76) \left\{ (1.093)(754.4 - 616.2) - (303) \left[(1.093) \ln \left(\frac{754.4}{616.2} \right) - 0 \right] \right\} \\ &= 1073 \text{ kW} \end{aligned}$$

$$\begin{aligned}\Delta\dot{X}_{\text{regen,cold}} &= \dot{m} \left\{ c_p (T_5 - T_2) - T_0 \left[c_p \ln \frac{T_5}{T_2} - 0 \right] \right\} \\ &= (12.76) \left\{ (1.093)(673 - 533) - (303) \left[(1.093) \ln \left(\frac{673}{533} \right) - 0 \right] \right\} \\ &= 954.8 \text{ kW}\end{aligned}$$

$$\eta_{II,T} = \frac{\Delta\dot{X}_{\text{regen,cold}}}{\Delta\dot{X}_{\text{regen,hot}}} = \frac{954.8 \text{ kW}}{1073 \text{ kW}} = \mathbf{0.890}$$

The exergy of the combustion gases at the regenerator exit:

$$\begin{aligned}\dot{X}_6 &= \dot{m} \left\{ c_p (T_6 - T_0) - T_0 \left[c_p \ln \frac{T_6}{T_0} - 0 \right] \right\} \\ &= (12.76) \left\{ (1.093)(616.2 - 303) - (303) \left[(1.093) \ln \left(\frac{616.2}{303} \right) - 0 \right] \right\} \\ &= \mathbf{1351 \text{ kW}}\end{aligned}$$

9-149 A modern compression ignition engine operates on the ideal dual cycle. The maximum temperature in the cycle, the net work output, the thermal efficiency, the mean effective pressure, the net power output, the second-law efficiency of the cycle, and the rate of exergy of the exhaust gases are to be determined.

Assumptions 1 The air-standard assumptions are applicable. **2** Kinetic and potential energy changes are negligible. **3** Air is an ideal gas with constant specific heats.

Properties The properties of air at 1000 K are $c_p = 1.142 \text{ kJ/kg}\cdot\text{K}$, $c_v = 0.855 \text{ kJ/kg}\cdot\text{K}$, $R = 0.287 \text{ kJ/kg}\cdot\text{K}$, and $k = 1.336$ (Table A-2b).

Analysis (a) The clearance volume and the total volume of the engine at the beginning of compression process (state 1) are

$$r = \frac{V_c + V_d}{V_c} \rightarrow 16 = \frac{V_c + 0.0018 \text{ m}^3}{V_c} \rightarrow V_c = 0.00012 \text{ m}^3 = V_2 = V_x$$

$$V_1 = V_c + V_d = 0.00012 + 0.0018 = 0.00192 \text{ m}^3 = V_4$$

Process 1-2: Isentropic compression

$$T_2 = T_1 \left(\frac{V_1}{V_2} \right)^{k-1} = (343 \text{ K})(16)^{1.3361} = 870.7 \text{ K}$$

$$P_2 = P_1 \left(\frac{V_1}{V_2} \right)^k = (95 \text{ kPa})(16)^{1.336} = 3859 \text{ kPa}$$

Process 2-x and x-3: Constant-volume and constant pressure heat addition processes:

$$T_x = T_2 \frac{P_x}{P_2} = (870.7 \text{ K}) \frac{7500 \text{ kPa}}{3859 \text{ kPa}} = 1692 \text{ K}$$

$$q_{2-x} = c_v(T_x - T_2) = (0.855 \text{ kJ/kg}\cdot\text{K})(1692 - 870.7) \text{ K} = 702.6 \text{ kJ/kg}$$

$$q_{2-x} = q_{x-3} = c_p(T_3 - T_x) \rightarrow 702.6 \text{ kJ/kg} = (0.855 \text{ kJ/kg}\cdot\text{K})(T_3 - 1692) \text{ K} \rightarrow T_3 = \mathbf{2308 \text{ K}}$$

(b) $q_{in} = q_{2-x} + q_{x-3} = 702.6 + 702.6 = 1405 \text{ kJ/kg}$

$$V_3 = V_x \frac{T_3}{T_x} = (0.00012 \text{ m}^3) \frac{2308 \text{ K}}{1692 \text{ K}} = 0.0001636 \text{ m}^3$$

Process 3-4: isentropic expansion.

$$T_4 = T_3 \left(\frac{V_3}{V_4} \right)^{k-1} = (2308 \text{ K}) \left(\frac{0.0001636 \text{ m}^3}{0.00192 \text{ m}^3} \right)^{1.3361} = 1009 \text{ K}$$

$$P_4 = P_3 \left(\frac{V_3}{V_4} \right)^k = (7500 \text{ kPa}) \left(\frac{0.0001636 \text{ m}^3}{0.00192 \text{ m}^3} \right)^{1.336} = 279.4 \text{ kPa}$$

Process 4-1: constant volume heat rejection.

$$q_{out} = c_v(T_4 - T_1) = (0.855 \text{ kJ/kg}\cdot\text{K})(1009 - 343) \text{ K} = 569.3 \text{ kJ/kg}$$

The net work output and the thermal efficiency are

$$w_{net,out} = q_{in} - q_{out} = 1405 - 569.3 = \mathbf{835.8 \text{ kJ/kg}}$$

$$\eta_{th} = \frac{w_{net,out}}{q_{in}} = \frac{835.8 \text{ kJ/kg}}{1405 \text{ kJ/kg}} = 0.5948 = \mathbf{59.5\%}$$

(c) The mean effective pressure is determined to be

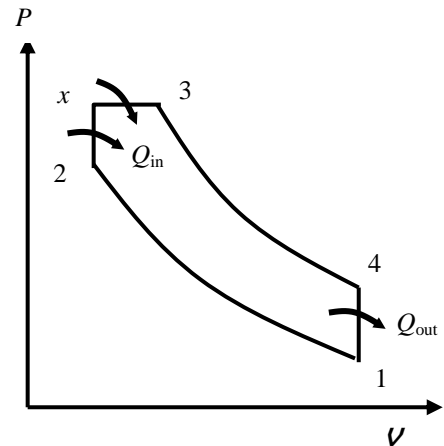

$$m = \frac{P_1 v_1}{RT_1} = \frac{(95 \text{ kPa})(0.00192 \text{ m}^3)}{(0.287 \text{ kPa} \cdot \text{m}^3/\text{kg} \cdot \text{K})(343 \text{ K})} = 0.001853 \text{ kg}$$

$$\text{MEP} = \frac{mw_{\text{net,out}}}{v_1 - v_2} = \frac{(0.001853 \text{ kg})(835.8 \text{ kJ/kg})}{(0.00192 - 0.00012) \text{ m}^3} \left(\frac{\text{kPa} \cdot \text{m}^3}{\text{kJ}} \right) = \mathbf{860.4 \text{ kPa}}$$

(d) The power for engine speed of 3500 rpm is

$$\dot{W}_{\text{net}} = mw_{\text{net}} \frac{\dot{n}}{2} = (0.001853 \text{ kg})(835.8 \text{ kJ/kg}) \frac{2200 \text{ (rev/min)}}{(2 \text{ rev/cycle})} \left(\frac{1 \text{ min}}{60 \text{ s}} \right) = \mathbf{28.39 \text{ kW}}$$

Note that there are two revolutions in one cycle in four-stroke engines.

(e) The second-law efficiency of the cycle is defined as the ratio of actual thermal efficiency to the maximum possible thermal efficiency (Carnot efficiency). We take the dead state temperature and pressure to be 25°C and 100 kPa.

$$\eta_{\text{max}} = 1 - \frac{T_0}{T_3} = 1 - \frac{(25 + 273) \text{ K}}{2308 \text{ K}} = 0.8709$$

and

$$\eta_{\text{II}} = \frac{\eta_{\text{th}}}{\eta_{\text{max}}} = \frac{0.5948}{0.8709} = 0.683 = \mathbf{68.3\%}$$

The rate of exergy of the exhaust gases is determined as follows

$$v_4 = \frac{v_4}{m} = \frac{0.00192 \text{ m}^3}{0.001853 \text{ kg}} = 1.036 \text{ m}^3/\text{kg}$$

$$v_0 = \frac{RT_0}{P_0} = \frac{(0.287 \text{ kPa} \cdot \text{m}^3/\text{kg} \cdot \text{K})(298 \text{ K})}{100 \text{ kPa}} = 0.8553 \text{ m}^3/\text{kg}$$

$$\begin{aligned} x_4 &= u_4 - u_0 + P_0(v_4 - v_0) - T_0(s_4 - s_0) = c_v(T_4 - T_0) + P_0(v_4 - v_0) - T_0 \left[c_p \ln \frac{T_4}{T_0} - R \ln \frac{P_4}{P_0} \right] \\ &= (0.855)(1009 - 298) + (100 \text{ kPa})(1.036 - 0.8533) \text{ m}^3/\text{kg} \\ &\quad - (298 \text{ K}) \left[(1.142 \text{ kJ/kg} \cdot \text{K}) \ln \frac{1009}{298} - (0.287 \text{ kJ/kg} \cdot \text{K}) \ln \frac{279.4}{100} \right] \\ &= 303.3 \text{ kJ/kg} \end{aligned}$$

$$\dot{X}_4 = mx_4 \frac{\dot{n}}{2} = (0.001853 \text{ kg})(303.3 \text{ kJ/kg}) \frac{2200 \text{ (rev/min)}}{(2 \text{ rev/cycle})} \left(\frac{1 \text{ min}}{60 \text{ s}} \right) = \mathbf{10.30 \text{ kW}}$$

Review Problems

9-150 A Carnot cycle executed in a closed system uses air as the working fluid. The net work output per cycle is to be determined.

Assumptions 1 Air is an ideal gas with variable specific heats.

Properties The gas constant of air is $R = 0.287 \text{ kJ/kg}\cdot\text{K}$ (Table A-1).

Analysis (a) The maximum temperature is determined from

$$\eta_{th} = 1 - \frac{T_L}{T_H} \longrightarrow 0.60 = 1 - \frac{300 \text{ K}}{T_H} \longrightarrow T_H = 750 \text{ K}$$

$$\begin{aligned} s_2 - s_1 &= s_2^{\circ} - s_1^{\circ} - R \ln \frac{P_2}{P_1} = -(0.287 \text{ kJ/kg}\cdot\text{K}) \ln \frac{700 \text{ kPa}}{1000 \text{ kPa}} \\ &= 0.1204 \text{ kJ/kg}\cdot\text{K} \end{aligned}$$

$$\begin{aligned} W_{net} &= m(s_2 - s_1)(T_H - T_L) \\ &= (0.0025 \text{ kg})(0.1024 \text{ kJ/kg}\cdot\text{K})(750 - 300)\text{K} \\ &= \mathbf{0.115 \text{ kJ}} \end{aligned}$$

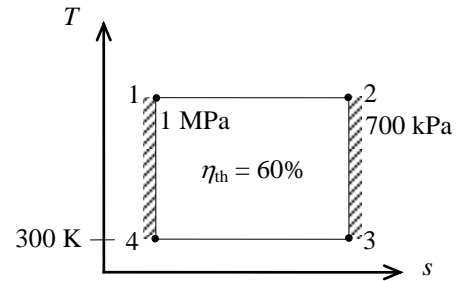

9-151 The four processes of an air-standard cycle are described. The cycle is to be shown on P - v and T - s diagrams, and the net work output and the thermal efficiency are to be determined.

Assumptions 1 The air-standard assumptions are applicable. **2** Kinetic and potential energy changes are negligible. **3** Air is an ideal gas with variable specific heats.

Properties The properties of air are given in Table A-17.

Analysis (b) We treat air as an ideal gas with variable specific heats,

$$T_1 = 300 \text{ K} \longrightarrow u_1 = 214.07 \text{ kJ/kg}$$

$$h_1 = 300.19 \text{ kJ/kg}$$

$$\frac{P_2 v_2}{T_2} = \frac{P_1 v_1}{T_1} \longrightarrow T_2 = \frac{P_2}{P_1} T_1 = \left(\frac{300 \text{ kPa}}{100 \text{ kPa}} \right) (300 \text{ K})$$

$$= 900 \text{ K} \longrightarrow u_2 = 674.58 \text{ kJ/kg}$$

$$h_2 = 932.93 \text{ kJ/kg}$$

$$T_3 = 1300 \text{ K} \longrightarrow u_3 = 1022.82 \text{ kJ/kg}$$

$$h_3 = 1395.97 \text{ kJ/kg}, P_{r3} = 330.9$$

$$P_{r4} = \frac{P_4}{P_3} P_{r3} = \left(\frac{100 \text{ kPa}}{300 \text{ kPa}} \right) (330.9) = 110.3$$

$$\longrightarrow h_4 = 1036.46 \text{ kJ/kg}$$

$$\begin{aligned} q_{\text{in}} &= q_{12, \text{in}} + q_{23, \text{in}} = (u_2 - u_1) + (h_3 - h_2) \\ &= (674.58 - 214.07) + (1395.97 - 932.93) \\ &= 923.55 \text{ kJ/kg} \end{aligned}$$

$$q_{\text{out}} = h_4 - h_1 = 1036.46 - 300.19 = 736.27 \text{ kJ/kg}$$

$$w_{\text{net}} = q_{\text{in}} - q_{\text{out}} = 923.55 - 736.27 = \mathbf{187.28 \text{ kJ/kg}}$$

$$(c) \quad \eta_{\text{th}} = \frac{w_{\text{net}}}{q_{\text{in}}} = \frac{187.28 \text{ kJ/kg}}{923.55 \text{ kJ/kg}} = \mathbf{20.3\%}$$

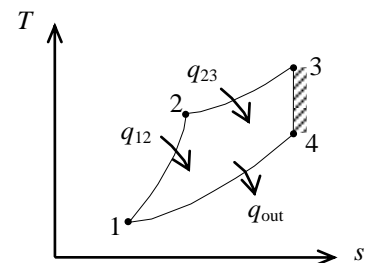
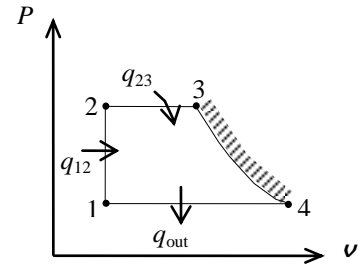

9-152 All four processes of an air-standard cycle are described. The cycle is to be shown on P - v and T - s diagrams, and the net work output and the thermal efficiency are to be determined.

Assumptions 1 The air-standard assumptions are applicable. **2** Kinetic and potential energy changes are negligible. **3** Air is an ideal gas with constant specific heats.

Properties The properties of air at room temperature are $c_p = 1.005 \text{ kJ/kg}\cdot\text{K}$, $c_v = 0.718 \text{ kJ/kg}\cdot\text{K}$, and $k = 1.4$ (Table A-2).

Analysis (b) Process 3-4 is isentropic:

$$T_4 = T_3 \left(\frac{P_4}{P_3} \right)^{(k-1)/k} = (1300 \text{ K}) \left(\frac{1}{3} \right)^{0.4/1.4} = 949.8 \text{ K}$$

$$\frac{P_2 v_2}{T_2} = \frac{P_1 v_1}{T_1} \longrightarrow T_2 = \frac{P_2}{P_1} T_1 = \left(\frac{300 \text{ kPa}}{100 \text{ kPa}} \right) (300 \text{ K}) = 900 \text{ K}$$

$$\begin{aligned} q_{\text{in}} &= q_{12,\text{in}} + q_{23,\text{in}} = (u_2 - u_1) + (h_3 - h_2) = c_v(T_2 - T_1) + c_p(T_3 - T_2) \\ &= (0.718 \text{ kJ/kg}\cdot\text{K})(900 - 300)\text{K} + (1.005 \text{ kJ/kg}\cdot\text{K})(1300 - 900)\text{K} \\ &= 832.8 \text{ kJ/kg} \end{aligned}$$

$$\begin{aligned} q_{\text{out}} &= h_4 - h_1 = c_p(T_4 - T_1) = (1.005 \text{ kJ/kg}\cdot\text{K})(949.8 - 300)\text{K} \\ &= 653 \text{ kJ/kg} \end{aligned}$$

$$w_{\text{net}} = q_{\text{in}} - q_{\text{out}} = 832.8 - 653 = \mathbf{179.8 \text{ kJ/kg}}$$

$$(c) \quad \eta_{\text{th}} = \frac{w_{\text{net}}}{q_{\text{in}}} = \frac{179.8 \text{ kJ/kg}}{832.8 \text{ kJ/kg}} = \mathbf{21.6\%}$$

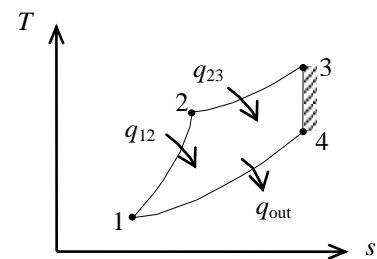
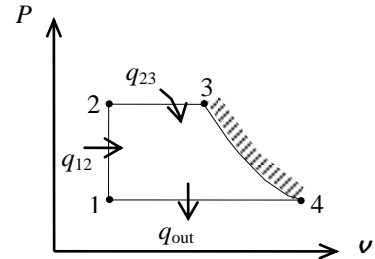

9-153 An Otto cycle with a compression ratio of 10.5 is considered. The thermal efficiency is to be determined using constant and variable specific heats.

Assumptions 1 The air-standard assumptions are applicable. **2** Kinetic and potential energy changes are negligible.

Properties The properties of air at room temperature are $R = 0.287 \text{ kPa} \cdot \text{m}^3/\text{kg} \cdot \text{K}$, $c_p = 1.005 \text{ kJ/kg} \cdot \text{K}$, $c_v = 0.718 \text{ kJ/kg} \cdot \text{K}$, and $k = 1.4$ (Table A-2a).

Analysis (a) Constant specific heats:

$$\eta_{\text{th}} = 1 - \frac{1}{r^{k-1}} = 1 - \frac{1}{10.5^{1.4-1}} = 0.6096 = \mathbf{61.0\%}$$

(b) Variable specific heats: (using air properties from Table A-17)

Process 1-2: isentropic compression.

$$T_1 = 308 \text{ K} \longrightarrow \begin{aligned} u_1 &= 219.82 \text{ kJ/kg} \\ v_{r1} &= 581.8 \end{aligned}$$

$$v_{r2} = \frac{v_2}{v_1} v_{r1} = \frac{1}{r} v_{r1} = \frac{1}{10.5} (581.8) = 55.41 \longrightarrow u_2 = 560.55 \text{ kJ/kg}$$

Process 2-3: $v = \text{constant}$ heat addition.

$$T_3 = 1273 \text{ K} \longrightarrow \begin{aligned} u_3 &= 998.51 \text{ kJ/kg} \\ v_{r3} &= 12.045 \end{aligned}$$

$$q_{\text{in}} = u_3 - u_2 = 998.51 - 560.55 = 437.96 \text{ kJ/kg}$$

Process 3-4: isentropic expansion.

$$v_{r4} = \frac{v_4}{v_3} v_{r3} = r v_{r3} = (10.5)(12.045) = 126.5 \longrightarrow u_4 = 405.11 \text{ kJ/kg}$$

Process 4-1: $v = \text{constant}$ heat rejection.

$$q_{\text{out}} = u_4 - u_1 = 405.11 - 219.82 = 185.29 \text{ kJ/kg}$$

$$\eta_{\text{th}} = 1 - \frac{q_{\text{out}}}{q_{\text{in}}} = 1 - \frac{185.29 \text{ kJ/kg}}{437.96 \text{ kJ/kg}} = 0.5769 = \mathbf{57.7\%}$$

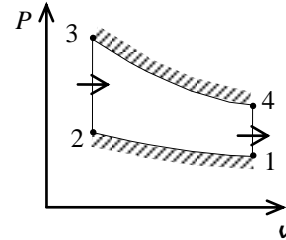

9-154E An ideal diesel engine with air as the working fluid has a compression ratio of 20. The thermal efficiency is to be determined using constant and variable specific heats.

Assumptions 1 The air-standard assumptions are applicable. **2** Kinetic and potential energy changes are negligible. **3** Air is an ideal gas with constant specific heats.

Properties The properties of air at room temperature are $c_p = 0.240$ Btu/lbm·R, $c_v = 0.171$ Btu/lbm·R, $R = 0.06855$ Btu/lbm·R, and $k = 1.4$ (Table A-2Ea).

Analysis (a) Constant specific heats:

Process 1-2: isentropic compression.

$$T_2 = T_1 \left(\frac{v_1}{v_2} \right)^{k-1} = (505 \text{ R})(20)^{0.4} = 1673.8 \text{ R}$$

Process 2-3: $P = \text{constant}$ heat addition.

$$\frac{P_3 v_3}{T_3} = \frac{P_2 v_2}{T_2} \longrightarrow \frac{v_3}{v_2} = \frac{T_3}{T_2} = \frac{2260 \text{ R}}{1673.8 \text{ R}} = 1.350$$

Process 3-4: isentropic expansion.

$$T_4 = T_3 \left(\frac{v_3}{v_4} \right)^{k-1} = T_3 \left(\frac{1.350 v_2}{v_4} \right)^{k-1} = T_3 \left(\frac{1.350}{r} \right)^{k-1} = (2260 \text{ R}) \left(\frac{1.350}{20} \right)^{0.4} = 768.8 \text{ R}$$

$$q_{\text{in}} = h_3 - h_2 = c_p (T_3 - T_2) = (0.240 \text{ Btu/lbm} \cdot \text{R})(2260 - 1673.8) \text{ R} = 140.7 \text{ Btu/lbm}$$

$$q_{\text{out}} = u_4 - u_1 = c_v (T_4 - T_1) = (0.171 \text{ Btu/lbm} \cdot \text{R})(768.8 - 505) \text{ R} = 45.11 \text{ Btu/lbm}$$

$$w_{\text{net,out}} = q_{\text{in}} - q_{\text{out}} = 140.7 - 45.11 = 95.59 \text{ Btu/lbm}$$

$$\eta_{\text{th}} = \frac{w_{\text{net,out}}}{q_{\text{in}}} = \frac{95.59 \text{ Btu/lbm}}{140.7 \text{ Btu/lbm}} = 0.6794 = \mathbf{67.9\%}$$

(b) Variable specific heats: (using air properties from Table A-17)

Process 1-2: isentropic compression.

$$T_1 = 505 \text{ R} \longrightarrow \begin{aligned} u_1 &= 86.06 \text{ Btu/lbm} \\ v_{r1} &= 170.82 \end{aligned}$$

$$v_{r2} = \frac{v_2}{v_1} v_{r1} = \frac{1}{r} v_{r1} = \frac{1}{20} (170.82) = 8.541 \longrightarrow \begin{aligned} T_2 &= 1582.3 \text{ R} \\ h_2 &= 391.01 \text{ Btu/lbm} \end{aligned}$$

Process 2-3: $P = \text{constant}$ heat addition.

$$\frac{P_3 v_3}{T_3} = \frac{P_2 v_2}{T_2} \longrightarrow \frac{v_3}{v_2} = \frac{T_3}{T_2} = \frac{2260 \text{ R}}{1582.3 \text{ R}} = 1.428$$

$$T_3 = 2260 \text{ R} \longrightarrow \begin{aligned} h_3 &= 577.52 \text{ Btu/lbm} \\ v_{r3} &= 2.922 \end{aligned}$$

$$q_{\text{in}} = h_3 - h_2 = 577.52 - 391.01 = 186.51 \text{ Btu/lbm}$$

Process 3-4: isentropic expansion.

$$v_{r4} = \frac{v_4}{v_3} v_{r3} = \frac{v_4}{1.428 v_2} v_{r3} = \frac{r}{1.428} v_{r3} = \frac{20}{1.428} (2.922) = 40.92 \longrightarrow u_4 = 152.65 \text{ Btu/lbm}$$

Process 4-1: $v = \text{constant}$ heat rejection.

$$q_{\text{out}} = u_4 - u_1 = 152.65 - 86.06 = 66.59 \text{ Btu/lbm}$$

$$\text{Then } \eta_{\text{th}} = 1 - \frac{q_{\text{out}}}{q_{\text{in}}} = 1 - \frac{66.59 \text{ Btu/lbm}}{186.51 \text{ Btu/lbm}} = 0.6430 = \mathbf{64.3\%}$$

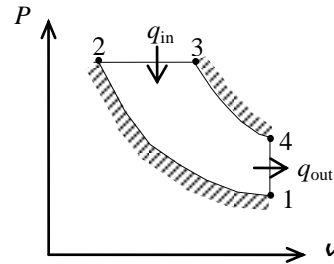

9-155E A simple ideal Brayton cycle with air as the working fluid operates between the specified temperature limits. The net work is to be determined using constant and variable specific heats.

Assumptions 1 Steady operating conditions exist. 2 The air-standard assumptions are applicable. 3 Kinetic and potential energy changes are negligible.

Properties The properties of air at room temperature are $c_p = 0.240$ Btu/lbm·R and $k = 1.4$ (Table A-2Ea).

Analysis (a) Constant specific heats:

$$T_2 = T_1 r_p^{(k-1)/k} = (480 \text{ R})(12)^{0.4/1.4} = 976.3 \text{ R}$$

$$T_4 = T_3 \left(\frac{1}{r_p} \right)^{(k-1)/k} = (1460 \text{ R}) \left(\frac{1}{12} \right)^{0.4/1.4} = 717.8 \text{ R}$$

$$\begin{aligned} w_{\text{net}} &= w_{\text{turb}} - w_{\text{comp}} \\ &= c_p (T_3 - T_4) - c_p (T_2 - T_1) \\ &= c_p (T_3 - T_4 + T_1 - T_2) \\ &= (0.240 \text{ Btu/lbm} \cdot \text{R})(1460 - 717.8 + 480 - 976.3) \text{ R} \\ &= \mathbf{59.0 \text{ Btu/lbm}} \end{aligned}$$

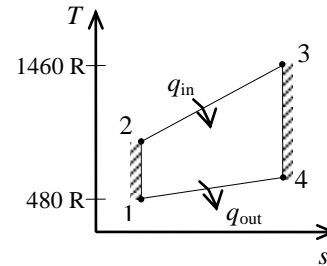

(b) Variable specific heats: (using air properties from Table A-17E)

$$T_1 = 480 \text{ R} \longrightarrow \begin{aligned} h_1 &= 114.69 \text{ Btu/lbm} \\ P_{r1} &= 0.9182 \end{aligned}$$

$$P_{r2} = \frac{P_2}{P_1} P_{r1} = (12)(0.9182) = 11.02 \longrightarrow h_2 = 233.63 \text{ Btu/lbm}$$

$$T_3 = 1460 \text{ R} \longrightarrow \begin{aligned} h_3 &= 358.63 \text{ Btu/lbm} \\ P_{r3} &= 50.40 \end{aligned}$$

$$P_{r4} = \frac{P_4}{P_3} P_{r3} = \left(\frac{1}{12} \right) (50.40) = 4.12 \longrightarrow h_4 = 176.32 \text{ Btu/lbm}$$

$$\begin{aligned} w_{\text{net}} &= w_{\text{turb}} - w_{\text{comp}} \\ &= (h_3 - h_4) - (h_2 - h_1) \\ &= (358.63 - 176.32) - (233.63 - 114.69) \\ &= \mathbf{63.4 \text{ Btu/lbm}} \end{aligned}$$

9-156 A turbocharged four-stroke V-16 diesel engine produces 4400 hp at 1500 rpm. The amount of work produced per cylinder per mechanical and per thermodynamic cycle is to be determined.

Analysis Noting that there are 16 cylinders and each thermodynamic cycle corresponds to 2 mechanical cycles (revolutions), we have

(a)

$$\begin{aligned} w_{\text{mechanical}} &= \frac{\text{Total power produced}}{(\text{No. of cylinders})(\text{No. of mechanical cycles})} \\ &= \frac{4400 \text{ hp}}{(16 \text{ cylinders})(1500 \text{ rev/min})} \left(\frac{42.41 \text{ Btu/min}}{1 \text{ hp}} \right) \\ &= \mathbf{7.78 \text{ Btu/cyl} \cdot \text{mech cycle}} \quad (= 7.37 \text{ kJ/cyl} \cdot \text{mech cycle}) \end{aligned}$$

(b)

$$\begin{aligned} w_{\text{thermodynamic}} &= \frac{\text{Total power produced}}{(\text{No. of cylinders})(\text{No. of thermodynamic cycles})} \\ &= \frac{4400 \text{ hp}}{(16 \text{ cylinders})(1500/2 \text{ rev/min})} \left(\frac{42.41 \text{ Btu/min}}{1 \text{ hp}} \right) \\ &= \mathbf{15.55 \text{ Btu/cyl} \cdot \text{therm cycle}} \quad (= 14.74 \text{ kJ/cyl} \cdot \text{therm cycle}) \end{aligned}$$

9-157 A simple ideal Brayton cycle operating between the specified temperature limits is considered. The pressure ratio for which the compressor and the turbine exit temperature of air are equal is to be determined.

Assumptions 1 Steady operating conditions exist. **2** The air-standard assumptions are applicable. **3** Kinetic and potential energy changes are negligible. **4** Air is an ideal gas with constant specific heats.

Properties The specific heat ratio of air is $k=1.4$ (Table A-2).

Analysis We treat air as an ideal gas with constant specific heats. Using the isentropic relations, the temperatures at the compressor and turbine exit can be expressed as

$$\begin{aligned} T_2 &= T_1 \left(\frac{P_2}{P_1} \right)^{(k-1)/k} = T_1 (r_p)^{(k-1)/k} \\ T_4 &= T_3 \left(\frac{P_4}{P_3} \right)^{(k-1)/k} = T_3 \left(\frac{1}{r_p} \right)^{(k-1)/k} \end{aligned}$$

Setting $T_2 = T_4$ and solving for r_p gives

$$r_p = \left(\frac{T_3}{T_1} \right)^{k/2(k-1)} = \left(\frac{1500 \text{ K}}{300 \text{ K}} \right)^{1.4/0.8} = \mathbf{16.7}$$

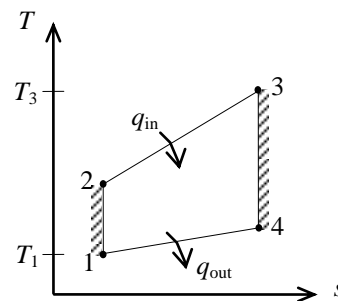

Therefore, the compressor and turbine exit temperatures will be equal when the compression ratio is 16.7.

9-158 A spark-ignition engine operates on an ideal Otto cycle with a compression ratio of 11. The maximum temperature and pressure in the cycle, the net work per cycle and per cylinder, the thermal efficiency, the mean effective pressure, and the power output for a specified engine speed are to be determined.

Assumptions 1 The air-standard assumptions are applicable. **2** Kinetic and potential energy changes are negligible. **3** Air is an ideal gas with variable specific heats.

Properties The gas constant of air is $R = 0.287 \text{ kJ/kg}\cdot\text{K}$ (Table A-1).

Analysis (a) First the mass in one cylinder is determined as follows

$$r = \frac{V_c + V_d}{V_c} \rightarrow 11 = \frac{V_c + (0.0018)/4}{V_c} \rightarrow V_c = 0.000045 \text{ m}^3 \text{ for one cylinder}$$

$$V_1 = V_c + V_d = 0.000045 + 0.00045 = 0.000495 \text{ m}^3$$

$$m = \frac{P_1 V_1}{RT_1} = \frac{(90 \text{ kPa})(0.000495 \text{ m}^3)}{(0.287 \text{ kPa}\cdot\text{m}^3/\text{kg}\cdot\text{K})(323 \text{ K})} = 0.0004805 \text{ kg}$$

For this problem, we use the properties from EES software. Remember that for an ideal gas, enthalpy is a function of temperature only whereas entropy is functions of both temperature and pressure.

Process 1-2: Isentropic compression

$$T_1 = 50^\circ\text{C} = 323 \text{ K} \rightarrow u_1 = 230.88 \text{ kJ/kg}$$

$$\left. \begin{array}{l} T_1 = 50^\circ\text{C} = 323 \text{ K} \\ P_1 = 90 \text{ kPa} \end{array} \right\} s_1 = 5.8100 \text{ kJ/kg}\cdot\text{K}$$

$$v_1 = \frac{V_1}{m} = \frac{0.000495 \text{ m}^3}{0.0004805 \text{ kg}} = 1.0302 \text{ m}^3/\text{kg}$$

$$V_2 = V_c = 0.000045 \text{ m}^3$$

$$v_2 = \frac{V_2}{m} = \frac{0.000045 \text{ m}^3}{0.0004805 \text{ kg}} = 0.09364 \text{ m}^3/\text{kg}$$

$$\left. \begin{array}{l} s_2 = s_1 = 5.8100 \text{ kJ/kg}\cdot\text{K} \\ v_2 = 0.09364 \text{ m}^3/\text{kg} \end{array} \right\} T_2 = 807.3 \text{ K}$$

$$T_2 = 807.3 \text{ K} \rightarrow u_2 = 598.33 \text{ kJ/kg}$$

$$P_2 = P_1 \frac{v_1}{v_2} \frac{T_2}{T_1} = (90 \text{ kPa}) \left(\frac{0.000495 \text{ m}^3}{0.000045 \text{ m}^3} \right) \left(\frac{807.3 \text{ K}}{323 \text{ K}} \right) = 2474 \text{ kPa}$$

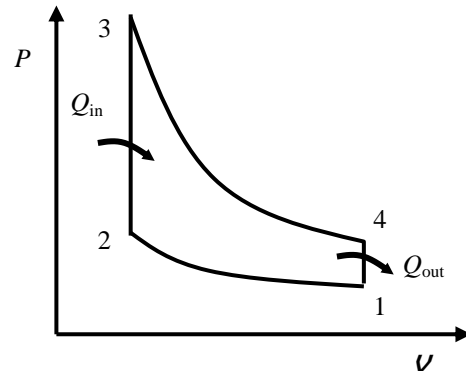

Process 2-3: constant volume heat addition

$$Q_{\text{in}} = m(u_3 - u_2) \rightarrow 1.5 \text{ kJ} = (0.0004805 \text{ kg})(u_3 - 598.33 \text{ kJ/kg}) \rightarrow u_3 = 3719.8 \text{ kJ/kg}$$

$$u_2 = 598.33 \text{ kJ/kg} \rightarrow T_3 = \mathbf{4037 \text{ K}}$$

$$P_3 = P_2 \left(\frac{T_3}{T_2} \right) = (2474 \text{ kPa}) \left(\frac{4037 \text{ K}}{807.3 \text{ K}} \right) = \mathbf{12,375 \text{ kPa}}$$

$$\left. \begin{array}{l} T_3 = 4037 \text{ K} \\ P_3 = 12,375 \text{ kPa} \end{array} \right\} s_3 = 7.3218 \text{ kJ/kg}\cdot\text{K}$$

(b) Process 3-4: isentropic expansion.

$$\left. \begin{array}{l} s_4 = s_3 = 7.3218 \text{ kJ/kg}\cdot\text{K} \\ v_4 = v_1 = 1.0302 \text{ m}^3/\text{kg} \end{array} \right\} T_4 = 2028 \text{ K}$$

$$T_4 = 2028 \text{ K} \longrightarrow u_4 = 1703.6 \text{ kJ/kg}$$

$$P_4 = P_3 \frac{V_3}{V_4} \frac{T_4}{T_3} = (12,375 \text{ kPa}) \left(\frac{1}{11} \right) \left(\frac{2028 \text{ K}}{4037 \text{ K}} \right) = 565 \text{ kPa}$$

Process 4-1: constant volume heat rejection

$$Q_{\text{out}} = m(u_4 - u_1) = (0.0004805 \text{ kg})(1703.6 - 230.88) \text{ kJ/kg} = 0.7077 \text{ kJ}$$

The net work output and the thermal efficiency are

$$W_{\text{net,out}} = Q_{\text{in}} - Q_{\text{out}} = 1.5 - 0.7077 = \mathbf{0.792 \text{ kJ}} \text{ (per cycle per cylinder)}$$

$$\eta_{\text{th}} = \frac{W_{\text{net,out}}}{Q_{\text{in}}} = \frac{0.792 \text{ kJ}}{1.5 \text{ kJ}} = \mathbf{0.528}$$

(c) The mean effective pressure is determined to be

$$\text{MEP} = \frac{W_{\text{net,out}}}{V_1 - V_2} = \frac{0.7923 \text{ kJ}}{(0.000495 - 0.000045) \text{ m}^3} \left(\frac{\text{kPa} \cdot \text{m}^3}{\text{kJ}} \right) = \mathbf{1761 \text{ kPa}}$$

(d) The power for engine speed of 3000 rpm is

$$\dot{W}_{\text{net}} = n_{\text{cyl}} W_{\text{net}} \frac{\dot{n}}{n_{\text{rev}}} = (4 \text{ cylinder})(0.792 \text{ kJ/cylinder - cycle}) \frac{(3000 \text{ rev/min}) \left(\frac{1 \text{ min}}{60 \text{ s}} \right)}{(2 \text{ rev/cycle})} = \mathbf{79.2 \text{ kW}}$$

Note that there are two revolutions in one cycle in four-stroke engines.

9-159  A four-cylinder spark-ignition engine with a compression ratio of 8 is considered. The amount of heat supplied per cylinder, the thermal efficiency, and the rpm for a net power output of 60 kW are to be determined.

Assumptions **1** The air-standard assumptions are applicable. **2** Kinetic and potential energy changes are negligible. **3** Air is an ideal gas with variable specific heats.

Properties The gas constant of air is $R = 0.287 \text{ kJ/kg}\cdot\text{K}$ (Table A-1). The properties of air are given in Table A-17.

Analysis (a) Process 1-2: isentropic compression.

$$T_1 = 310 \text{ K} \longrightarrow u_1 = 221.25 \text{ kJ/kg}$$

$$v_{r_1} = 572.3$$

$$v_{r_2} = \frac{v_2}{v_1} v_{r_1} = \frac{1}{r} v_{r_1} = \frac{1}{10.5} (572.3) = 54.50$$

$$\longrightarrow u_2 = 564.29 \text{ kJ/kg}$$

Process 2-3: $v = \text{constant}$ heat addition.

$$T_3 = 2100 \text{ K} \longrightarrow u_3 = 1775.3 \text{ kJ/kg}$$

$$v_{r_3} = 2.356$$

$$m = \frac{P_1 V_1}{RT_1} = \frac{(98 \text{ kPa})(0.0004 \text{ m}^3)}{(0.287 \text{ kPa}\cdot\text{m}^3/\text{kg}\cdot\text{K})(310 \text{ K})} = 4.406 \times 10^{-4} \text{ kg}$$

$$Q_{\text{in}} = m(u_3 - u_2) = (4.406 \times 10^{-4} \text{ kg})(1775.3 - 564.29) \text{ kJ/kg} = \mathbf{0.5336 \text{ kJ}}$$

(b) Process 3-4: isentropic expansion.

$$v_{r_4} = \frac{v_4}{v_3} v_{r_3} = r v_{r_3} = (10.5)(2.356) = 24.74 \longrightarrow u_4 = 764.05 \text{ kJ/kg}$$

Process 4-1: $v = \text{constant}$ heat rejection.

$$Q_{\text{out}} = m(u_4 - u_1) = (4.406 \times 10^{-4} \text{ kg})(764.05 - 221.25) \text{ kJ/kg} = 0.2392 \text{ kJ}$$

$$W_{\text{net}} = Q_{\text{in}} - Q_{\text{out}} = 0.5336 - 0.2392 = 0.2944 \text{ kJ}$$

$$\eta_{\text{th}} = \frac{W_{\text{net}}}{Q_{\text{in}}} = \frac{0.2944 \text{ kJ}}{0.5336 \text{ kJ}} = 0.5517 = \mathbf{55.2\%}$$

$$(c) \quad \dot{n} = 2 \frac{\dot{W}_{\text{net}}}{n_{\text{cyl}} W_{\text{net,cyl}}} = (2 \text{ rev/cycle}) \frac{45 \text{ kJ/s}}{4 \times (0.2944 \text{ kJ/cycle})} \left(\frac{60 \text{ s}}{1 \text{ min}} \right) = \mathbf{4586 \text{ rpm}}$$

Note that for four-stroke cycles, there are two revolutions per cycle.

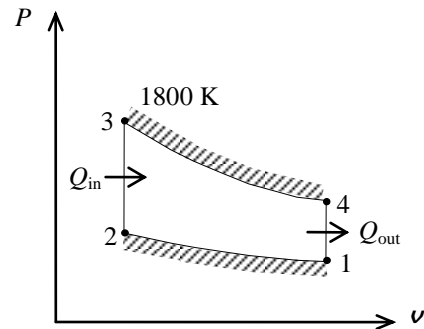



9-160 Problem 9-159 is reconsidered. The effect of the compression ratio net work done and the efficiency of the cycle is to be investigated. Also, the T - s and P - v diagrams for the cycle are to be plotted.

Analysis Using EES, the problem is solved as follows:

"Input Data"

$T[1]=(37+273)$ [K]
 $P[1]=98$ [kPa]
 $T[3]= 2100$ [K]
 $V_{cyl}=0.4$ [L]*Convert(L, m^3)
 $r_v=10.5$ "Compression ratio"
 $W_{dot_net} = 45$ [kW]
 $N_{cyl}=4$ "number of cylinders"
 $v[1]/v[2]=r_v$

"The first part of the solution is done per unit mass."

"Process 1-2 is isentropic compression"

$s[1]=\text{entropy}(\text{air}, T=T[1], P=P[1])$
 $s[2]=s[1]$
 $s[2]=\text{entropy}(\text{air}, T=T[2], v=v[2])$
 $P[2]*v[2]/T[2]=P[1]*v[1]/T[1]$
 $P[1]*v[1]=R*T[1]$
 $R=0.287$ [kJ/kg-K]

"Conservation of energy for process 1 to 2: no heat transfer ($s=\text{const.}$) with work input"

$w_{in} = \Delta u_{12}$
 $\Delta u_{12}=\text{intenergy}(\text{air}, T=T[2])-\text{intenergy}(\text{air}, T=T[1])$

"Process 2-3 is constant volume heat addition"

$s[3]=\text{entropy}(\text{air}, T=T[3], P=P[3])$
 $\{P[3]*v[3]/T[3]=P[2]*v[2]/T[2]\}$
 $P[3]*v[3]=R*T[3]$
 $v[3]=v[2]$

"Conservation of energy for process 2 to 3: the work is zero for $v=\text{const.}$, heat is added"

$q_{in} = \Delta u_{23}$
 $\Delta u_{23}=\text{intenergy}(\text{air}, T=T[3])-\text{intenergy}(\text{air}, T=T[2])$

"Process 3-4 is isentropic expansion"

$s[4]=\text{entropy}(\text{air}, T=T[4], P=P[4])$
 $s[4]=s[3]$
 $P[4]*v[4]/T[4]=P[3]*v[3]/T[3]$
 $\{P[4]*v[4]=R*T[4]\}$

"Conservation of energy for process 3 to 4: no heat transfer ($s=\text{const.}$) with work output"

$-w_{out} = \Delta u_{34}$
 $\Delta u_{34}=\text{intenergy}(\text{air}, T=T[4])-\text{intenergy}(\text{air}, T=T[3])$

"Process 4-1 is constant volume heat rejection"

$v[4]=v[1]$

"Conservation of energy for process 4 to 1: the work is zero for $v=\text{const.}$; heat is rejected"

$-q_{out} = \Delta u_{41}$
 $\Delta u_{41}=\text{intenergy}(\text{air}, T=T[1])-\text{intenergy}(\text{air}, T=T[4])$
 $w_{net} = w_{out} - w_{in}$

$\text{Eta}_{th}=w_{net}/q_{in}$ *Convert(, %) "Thermal efficiency, in percent"

"The mass contained in each cylinder is found from the volume of the cylinder:"

$V_{cyl}=m*v[1]$

"The net work done per cycle is:"

$W_{dot_net}=m*w_{net}$ "kJ/cyl"* N_{cyl} * N_{dot} "mechanical cycles/min"*1"min"/60"s"*1"thermal cycle"/2"mechanical cycles"

r_v	η_{th} [%]	W_{net} [kJ/kg]
5	42	568.3
6	45.55	601.9
7	48.39	625.7
8	50.74	642.9
9	52.73	655.5
10	54.44	664.6
11	55.94	671.2

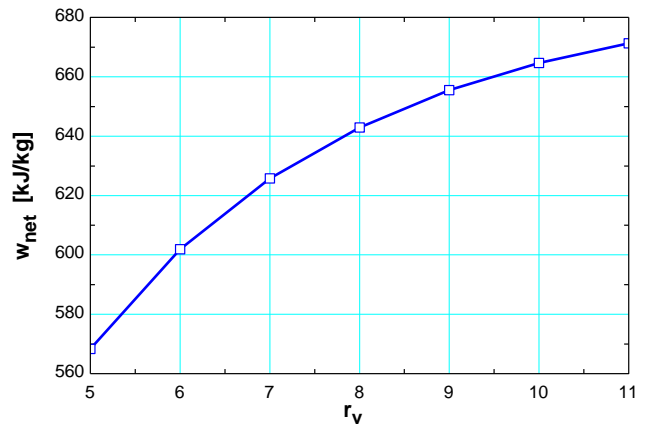
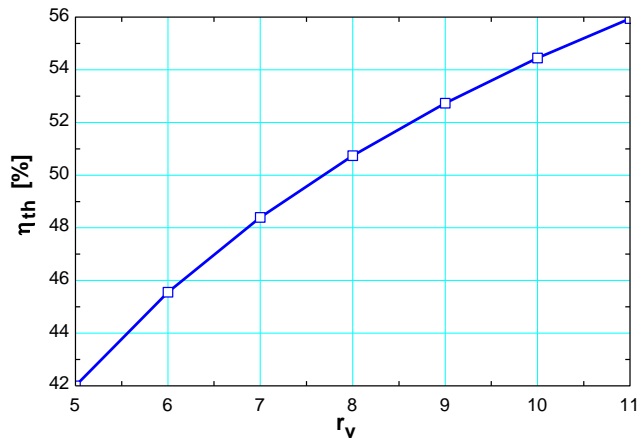
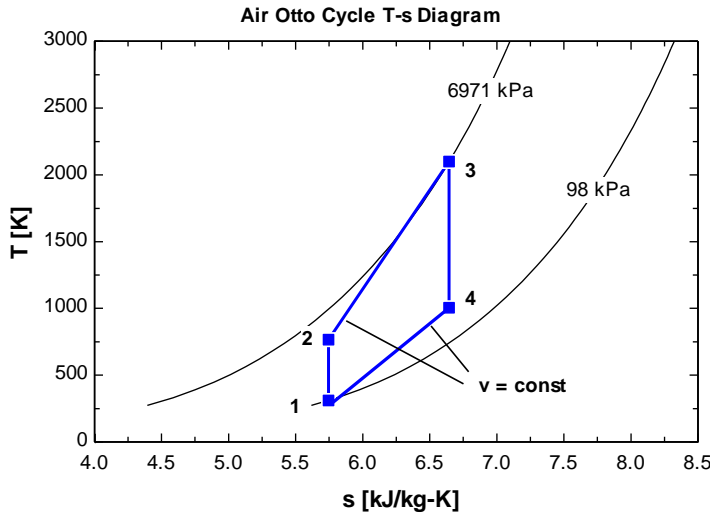
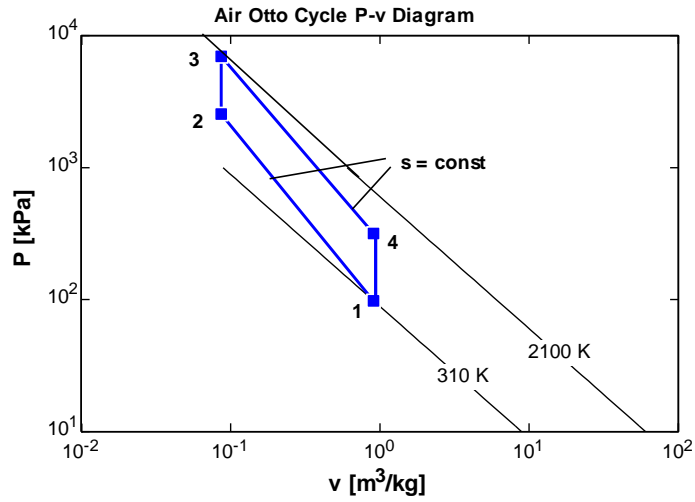

9-161 The compression ratio required for an ideal Otto cycle to produce certain amount of work when consuming a given amount of fuel is to be determined.

Assumptions 1 The air-standard assumptions are applicable. **2** Kinetic and potential energy changes are negligible. **3** Air is an ideal gas with constant specific heats. **4** The combustion efficiency is 100 percent.

Properties The properties of air at room temperature are $k = 1.4$ (Table A-2).

Analysis The heat input to the cycle for 0.039 grams of fuel consumption is

$$Q_{\text{in}} = m_{\text{fuel}} q_{\text{HV}} = (0.039 \times 10^{-3} \text{ kg})(43,000 \text{ kJ/kg}) = 1.677 \text{ kJ}$$

The thermal efficiency is then

$$\eta_{\text{th}} = \frac{W_{\text{net}}}{Q_{\text{in}}} = \frac{1 \text{ kJ}}{1.677 \text{ kJ}} = 0.5963$$

From the definition of thermal efficiency, we obtain the required compression ratio to be

$$\eta_{\text{th}} = 1 - \frac{1}{r^{k-1}} \longrightarrow r = \frac{1}{(1 - \eta_{\text{th}})^{1/(k-1)}} = \frac{1}{(1 - 0.5963)^{1/(1.4-1)}} = \mathbf{9.66}$$

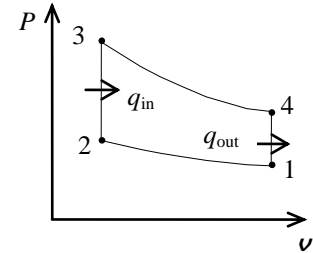

9-162E An ideal dual cycle with air as the working fluid with a compression ratio of 12 is considered. The thermal efficiency of the cycle is to be determined.

Assumptions 1 The air-standard assumptions are applicable. **2** Kinetic and potential energy changes are negligible. **3** Air is an ideal gas with constant specific heats.

Properties The properties of air at room temperature are $c_p = 0.240$ Btu/lbm·R, $c_v = 0.171$ Btu/lbm·R, and $k = 1.4$ (Table A-2E).

Analysis The mass of air is

$$m = \frac{P_1 V_1}{RT_1} = \frac{(14.7 \text{ psia})(98/1728 \text{ ft}^3)}{(0.3704 \text{ psia} \cdot \text{ft}^3/\text{lbm} \cdot \text{R})(580 \text{ R})} = 0.003881 \text{ lbm}$$

Process 1-2: isentropic compression.

$$T_2 = T_1 \left(\frac{V_1}{V_2} \right)^{k-1} = (580 \text{ R})(14)^{0.4} = 1667 \text{ R}$$

Process 2-x: $v = \text{constant}$ heat addition,

$$Q_{2-x,\text{in}} = m(u_x - u_2) = mc_v(T_x - T_2)$$

$$0.6 \text{ Btu} = (0.003881 \text{ lbm})(0.171 \text{ Btu/lbm} \cdot \text{R})(T_x - 1667) \text{ R} \longrightarrow T_x = 2571 \text{ R}$$

Process x-3: $P = \text{constant}$ heat addition.

$$Q_{x-3,\text{in}} = m(h_3 - h_x) = mc_p(T_3 - T_x)$$

$$1.1 \text{ Btu} = (0.003881 \text{ lbm})(0.240 \text{ Btu/lbm} \cdot \text{R})(T_3 - 2571) \text{ R} \longrightarrow T_3 = 3752 \text{ R}$$

$$\frac{P_3 V_3}{T_3} = \frac{P_x V_x}{T_x} \longrightarrow r_c = \frac{V_3}{V_x} = \frac{T_3}{T_x} = \frac{3752 \text{ R}}{2571 \text{ R}} = 1.459$$

Process 3-4: isentropic expansion.

$$T_4 = T_3 \left(\frac{V_3}{V_4} \right)^{k-1} = T_3 \left(\frac{1.459 V_1}{V_4} \right)^{k-1} = T_3 \left(\frac{1.459}{r} \right)^{k-1} = (3752 \text{ R}) \left(\frac{1.459}{14} \right)^{0.4} = 1519 \text{ R}$$

Process 4-1: $v = \text{constant}$ heat rejection.

$$Q_{\text{out}} = m(u_4 - u_1) = mc_v(T_4 - T_1)$$

$$= (0.003881 \text{ lbm})(0.171 \text{ Btu/lbm} \cdot \text{R})(1519 - 580) \text{ R} = 0.6229 \text{ Btu}$$

$$\eta_{\text{th}} = 1 - \frac{Q_{\text{out}}}{Q_{\text{in}}} = 1 - \frac{0.6229 \text{ Btu}}{1.7 \text{ Btu}} = 0.6336 = \mathbf{63.4\%}$$

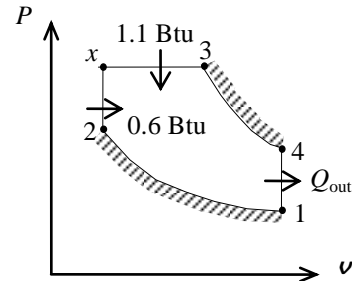

9-163 An ideal Stirling cycle with air as the working fluid is considered. The maximum pressure in the cycle and the net work output are to be determined.

Assumptions 1 The air-standard assumptions are applicable. 2 Kinetic and potential energy changes are negligible. 3 Air is an ideal gas with constant specific heats.

Properties The properties of air at room temperature are $R = 0.287$ kJ/kg·K, $c_p = 1.005$ kJ/kg·K, $c_v = 0.718$ kJ/kg·K, and $k = 1.4$ (Table A-2).

Analysis (a) The entropy change during process 1-2 is

$$s_2 - s_1 = \frac{q_{12}}{T_H} = \frac{750 \text{ kJ/kg}}{1800 \text{ K}} = 0.4167 \text{ kJ/kg} \cdot \text{K}$$

and

$$s_2 - s_1 = c_v \ln \frac{T_2}{T_1} + R \ln \frac{v_2}{v_1} \longrightarrow 0.4167 \text{ kJ/kg} \cdot \text{K} = (0.287 \text{ kJ/kg} \cdot \text{K}) \ln \frac{v_2}{v_1} \longrightarrow \frac{v_2}{v_1} = 4.271$$

$$\frac{P_3 v_3}{T_3} = \frac{P_1 v_1}{T_1} \longrightarrow P_1 = P_3 \frac{v_3}{v_1} \frac{T_1}{T_3} = P_3 \frac{v_2}{v_1} \frac{T_1}{T_3} = (200 \text{ kPa}) (4.271) \left(\frac{1800 \text{ K}}{400 \text{ K}} \right) = \mathbf{3844 \text{ kPa}}$$

(b) The net work output is

$$w_{\text{net}} = \eta_{\text{th}} q_{\text{in}} = \left(1 - \frac{T_L}{T_H} \right) q_{\text{in}} = \left(1 - \frac{400 \text{ K}}{1800 \text{ K}} \right) (750 \text{ kJ/kg}) = \mathbf{583 \text{ kJ/kg}}$$

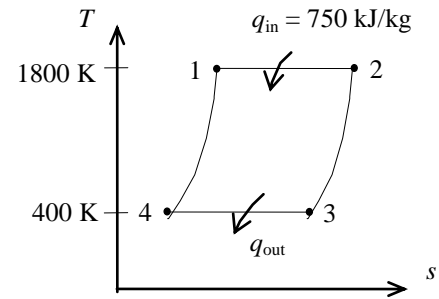

9-164 A simple ideal Brayton cycle with air as the working fluid is considered. The changes in the net work output per unit mass and the thermal efficiency are to be determined.

Assumptions 1 The air-standard assumptions are applicable. **2** Kinetic and potential energy changes are negligible. **3** Air is an ideal gas with variable specific heats.

Properties The properties of air are given in Table A-17.

Analysis The properties at various states are

$$T_1 = 300 \text{ K} \longrightarrow h_1 = 300.19 \text{ kJ/kg}$$

$$P_{r_1} = 1.386$$

$$T_3 = 1300 \text{ K} \longrightarrow h_3 = 1395.97 \text{ kJ/kg}$$

$$P_{r_3} = 330.9$$

For $r_p = 6$,

$$P_{r_2} = \frac{P_2}{P_1} P_{r_1} = (6)(1.386) = 8.316 \longrightarrow h_2 = 501.40 \text{ kJ/kg}$$

$$P_{r_4} = \frac{P_4}{P_3} P_{r_3} = \left(\frac{1}{6}\right)(330.9) = 55.15 \longrightarrow h_4 = 855.3 \text{ kJ/kg}$$

$$q_{\text{in}} = h_3 - h_2 = 1395.97 - 501.40 = 894.57 \text{ kJ/kg}$$

$$q_{\text{out}} = h_4 - h_1 = 855.3 - 300.19 = 555.11 \text{ kJ/kg}$$

$$w_{\text{net}} = q_{\text{in}} - q_{\text{out}} = 894.57 - 555.11 = 339.46 \text{ kJ/kg}$$

$$\eta_{\text{th}} = \frac{w_{\text{net}}}{q_{\text{in}}} = \frac{339.46 \text{ kJ/kg}}{894.57 \text{ kJ/kg}} = 37.9\%$$

For $r_p = 12$,

$$P_{r_2} = \frac{P_2}{P_1} P_{r_1} = (12)(1.386) = 16.63 \longrightarrow h_2 = 610.6 \text{ kJ/kg}$$

$$P_{r_4} = \frac{P_4}{P_3} P_{r_3} = \left(\frac{1}{12}\right)(330.9) = 27.58 \longrightarrow h_4 = 704.6 \text{ kJ/kg}$$

$$q_{\text{in}} = h_3 - h_2 = 1395.97 - 610.60 = 785.37 \text{ kJ/kg}$$

$$q_{\text{out}} = h_4 - h_1 = 704.6 - 300.19 = 404.41 \text{ kJ/kg}$$

$$w_{\text{net}} = q_{\text{in}} - q_{\text{out}} = 785.37 - 404.41 = 380.96 \text{ kJ/kg}$$

$$\eta_{\text{th}} = \frac{w_{\text{net}}}{q_{\text{in}}} = \frac{380.96 \text{ kJ/kg}}{785.37 \text{ kJ/kg}} = 48.5\%$$

Thus,

$$(a) \quad \Delta w_{\text{net}} = 380.96 - 339.46 = \mathbf{41.5 \text{ kJ/kg}} \quad (\text{increase})$$

$$(b) \quad \Delta \eta_{\text{th}} = 48.5\% - 37.9\% = \mathbf{10.6\%} \quad (\text{increase})$$

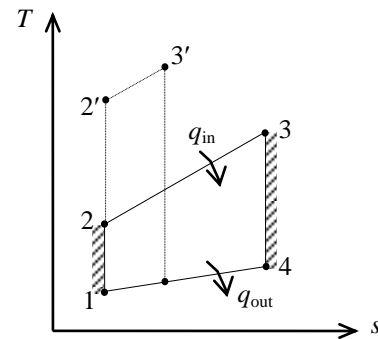

9-165 A simple ideal Brayton cycle with air as the working fluid is considered. The changes in the net work output per unit mass and the thermal efficiency are to be determined.

Assumptions 1 The air-standard assumptions are applicable. **2** Kinetic and potential energy changes are negligible. **3** Air is an ideal gas with constant specific heats.

Properties The properties of air at room temperature are $R = 0.287 \text{ kJ/kg}\cdot\text{K}$, $c_p = 1.005 \text{ kJ/kg}\cdot\text{K}$, $c_v = 0.718 \text{ kJ/kg}\cdot\text{K}$, and $k = 1.4$ (Table A-2).

Analysis Processes 1-2 and 3-4 are isentropic. Therefore, For $r_p = 6$,

$$T_2 = T_1 \left(\frac{P_2}{P_1} \right)^{(k-1)/k} = (300 \text{ K})(6)^{0.4/1.4} = 500.6 \text{ K}$$

$$T_4 = T_3 \left(\frac{P_4}{P_3} \right)^{(k-1)/k} = (1300 \text{ K}) \left(\frac{1}{6} \right)^{0.4/1.4} = 779.1 \text{ K}$$

$$q_{\text{in}} = h_3 - h_2 = c_p (T_3 - T_2) \\ = (1.005 \text{ kJ/kg}\cdot\text{K})(1300 - 500.6)\text{K} = 803.4 \text{ kJ/kg}$$

$$q_{\text{out}} = h_4 - h_1 = c_p (T_4 - T_1) \\ = (1.005 \text{ kJ/kg}\cdot\text{K})(779.1 - 300)\text{K} = 481.5 \text{ kJ/kg}$$

$$w_{\text{net}} = q_{\text{in}} - q_{\text{out}} = 803.4 - 481.5 = 321.9 \text{ kJ/kg}$$

$$\eta_{\text{th}} = \frac{w_{\text{net}}}{q_{\text{in}}} = \frac{321.9 \text{ kJ/kg}}{803.4 \text{ kJ/kg}} = 40.1\%$$

For $r_p = 12$,

$$T_2 = T_1 \left(\frac{P_2}{P_1} \right)^{(k-1)/k} = (300 \text{ K})(12)^{0.4/1.4} = 610.2 \text{ K}$$

$$T_4 = T_3 \left(\frac{P_4}{P_3} \right)^{(k-1)/k} = (1300 \text{ K}) \left(\frac{1}{12} \right)^{0.4/1.4} = 639.2 \text{ K}$$

$$q_{\text{in}} = h_3 - h_2 = c_p (T_3 - T_2) \\ = (1.005 \text{ kJ/kg}\cdot\text{K})(1300 - 610.2)\text{K} = 693.2 \text{ kJ/kg}$$

$$q_{\text{out}} = h_4 - h_1 = c_p (T_4 - T_1) \\ = (1.005 \text{ kJ/kg}\cdot\text{K})(639.2 - 300)\text{K} = 340.9 \text{ kJ/kg}$$

$$w_{\text{net}} = q_{\text{in}} - q_{\text{out}} = 693.2 - 340.9 = 352.3 \text{ kJ/kg}$$

$$\eta_{\text{th}} = \frac{w_{\text{net}}}{q_{\text{in}}} = \frac{352.3 \text{ kJ/kg}}{693.2 \text{ kJ/kg}} = 50.8\%$$

Thus,

$$(a) \quad \Delta w_{\text{net}} = 352.3 - 321.9 = \mathbf{30.4 \text{ kJ/kg}} \quad (\text{increase})$$

$$(b) \quad \Delta \eta_{\text{th}} = 50.8\% - 40.1\% = \mathbf{10.7\%} \quad (\text{increase})$$

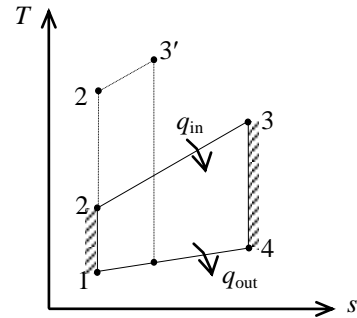

9-166 A regenerative Brayton cycle with helium as the working fluid is considered. The thermal efficiency and the required mass flow rate of helium are to be determined for 100 percent and 80 percent isentropic efficiencies for both the compressor and the turbine.

Assumptions 1 The air-standard assumptions are applicable. **2** Kinetic and potential energy changes are negligible. **3** Helium is an ideal gas with constant specific heats.

Properties The properties of helium are $c_p = 5.1926 \text{ kJ/kg}\cdot\text{K}$ and $k = 1.667$ (Table A-2).

Analysis (a) Assuming $\eta_T = \eta_C = 100\%$,

$$T_{2s} = T_1 \left(\frac{P_2}{P_1} \right)^{(k-1)/k} = (300 \text{ K})(8)^{0.667/1.667} = 689.4 \text{ K}$$

$$T_{4s} = T_3 \left(\frac{P_4}{P_3} \right)^{(k-1)/k} = (1800 \text{ K}) \left(\frac{1}{8} \right)^{0.667/1.667} = 783.3 \text{ K}$$

$$\varepsilon = \frac{h_5 - h_2}{h_4 - h_2} = \frac{c_p(T_5 - T_2)}{c_p(T_4 - T_2)} \longrightarrow T_5 = T_2 + \varepsilon(T_4 - T_2) = 689.4 + (0.75)(783.3 - 689.4) = 759.8 \text{ K}$$

$$w_{\text{net}} = w_{T,\text{out}} - w_{C,\text{in}} = (h_3 - h_4) - (h_2 - h_1) = c_p [(T_3 - T_4) - (T_2 - T_1)] \\ = (5.1926 \text{ kJ/kg}\cdot\text{K}) [(1800 - 783.3) - (689.4 - 300)] \text{ K} = 3257.3 \text{ kJ/kg}$$

$$\dot{m} = \frac{\dot{W}_{\text{net}}}{w_{\text{net}}} = \frac{60,000 \text{ kJ/s}}{3257.3 \text{ kJ/kg}} = \mathbf{18.42 \text{ kg/s}}$$

$$q_{\text{in}} = h_3 - h_5 = c_p(T_3 - T_5) = (5.1926 \text{ kJ/kg}\cdot\text{K})(1800 - 759.8) \text{ K} = 5401.3 \text{ kJ/kg}$$

$$\eta_{\text{th}} = \frac{w_{\text{net}}}{q_{\text{in}}} = \frac{3257.3 \text{ kJ/kg}}{5401.3 \text{ kJ/kg}} = \mathbf{60.3\%}$$

(b) Assuming $\eta_T = \eta_C = 80\%$,

$$T_{2s} = T_1 \left(\frac{P_2}{P_1} \right)^{(k-1)/k} = (300 \text{ K})(8)^{0.667/1.667} = 689.4 \text{ K}$$

$$\eta_C = \frac{h_{2s} - h_1}{h_2 - h_1} = \frac{c_p(T_{2s} - T_1)}{c_p(T_2 - T_1)} \longrightarrow T_2 = T_1 + (T_{2s} - T_1)/\eta_C = 300 + (689.4 - 300)/(0.80) = 786.8 \text{ K}$$

$$T_{4s} = T_3 \left(\frac{P_4}{P_3} \right)^{(k-1)/k} = (1800 \text{ K}) \left(\frac{1}{8} \right)^{0.667/1.667} = 783.3 \text{ K}$$

$$\eta_T = \frac{h_3 - h_4}{h_3 - h_{4s}} = \frac{c_p(T_3 - T_4)}{c_p(T_3 - T_{4s})} \longrightarrow T_4 = T_3 - \eta_T(T_3 - T_{4s}) = 1800 - (0.80)(1800 - 783.3) = 986.6 \text{ K}$$

$$\varepsilon = \frac{h_5 - h_2}{h_4 - h_2} = \frac{c_p(T_5 - T_2)}{c_p(T_4 - T_2)} \longrightarrow T_5 = T_2 + \varepsilon(T_4 - T_2) = 786.8 + (0.75)(986.6 - 786.8) = 936.7 \text{ K}$$

$$w_{\text{net}} = w_{T,\text{out}} - w_{C,\text{in}} = (h_3 - h_4) - (h_2 - h_1) = c_p [(T_3 - T_4) - (T_2 - T_1)] \\ = (5.1926 \text{ kJ/kg}\cdot\text{K}) [(1800 - 986.6) - (786.8 - 300)] \text{ K} = 1695.9 \text{ kJ/kg}$$

$$\dot{m} = \frac{\dot{W}_{\text{net}}}{w_{\text{net}}} = \frac{60,000 \text{ kJ/s}}{1695.9 \text{ kJ/kg}} = \mathbf{35.4 \text{ kg/s}}$$

$$q_{\text{in}} = h_3 - h_5 = c_p(T_3 - T_5) = (5.1926 \text{ kJ/kg}\cdot\text{K})(1800 - 936.7) \text{ K} = 4482.8 \text{ kJ/kg}$$

$$\eta_{\text{th}} = \frac{w_{\text{net}}}{q_{\text{in}}} = \frac{1695.9 \text{ kJ/kg}}{4482.8 \text{ kJ/kg}} = \mathbf{37.8\%}$$

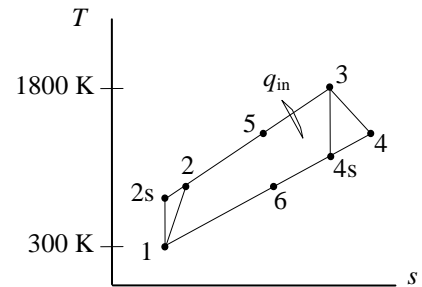

9-167 An ideal gas-turbine cycle with one stage of compression and two stages of expansion and regeneration is considered. The thermal efficiency of the cycle as a function of the compressor pressure ratio and the high-pressure turbine to compressor inlet temperature ratio is to be determined, and to be compared with the efficiency of the standard regenerative cycle.

Analysis The T - s diagram of the cycle is as shown in the figure. If the overall pressure ratio of the cycle is r_p , which is the pressure ratio across the compressor, then the pressure ratio across each turbine stage in the ideal case becomes $\sqrt{r_p}$. Using the isentropic relations, the temperatures at the compressor and turbine exit can be expressed as

$$T_5 = T_2 = T_1 \left(\frac{P_2}{P_1} \right)^{(k-1)/k} = T_1 (r_p)^{(k-1)/k}$$

$$T_7 = T_4 = T_3 \left(\frac{P_4}{P_3} \right)^{(k-1)/k} = T_3 \left(\frac{1}{\sqrt{r_p}} \right)^{(k-1)/k} = T_3 r_p^{(1-k)/2k}$$

$$T_6 = T_5 \left(\frac{P_6}{P_5} \right)^{(k-1)/k} = T_5 \left(\frac{1}{\sqrt{r_p}} \right)^{(k-1)/k} = T_2 r_p^{(1-k)/2k} = T_1 r_p^{(k-1)/k} r_p^{(1-k)/2k} = T_1 r_p^{(k-1)/2k}$$

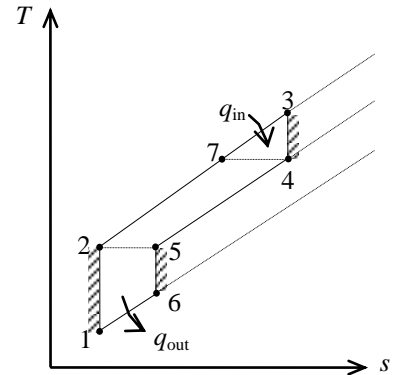

Then,

$$q_{in} = h_3 - h_7 = c_p (T_3 - T_7) = c_p T_3 (1 - r_p^{(1-k)/2k})$$

$$q_{out} = h_6 - h_1 = c_p (T_6 - T_1) = c_p T_1 (r_p^{(k-1)/2k} - 1)$$

and thus

$$\eta_{th} = 1 - \frac{q_{out}}{q_{in}} = 1 - \frac{c_p T_1 (r_p^{(k-1)/2k} - 1)}{c_p T_3 (1 - r_p^{(1-k)/2k})}$$

which simplifies to

$$\eta_{th} = 1 - \frac{T_1}{T_3} r_p^{(k-1)/2k}$$

The thermal efficiency of the single stage ideal regenerative cycle is given as

$$\eta_{th} = 1 - \frac{T_1}{T_3} r_p^{(k-1)/k}$$

Therefore, the regenerative cycle with two stages of expansion has a higher thermal efficiency than the standard regenerative cycle with a single stage of expansion for any given value of the pressure ratio r_p .

9-168 A gas-turbine plant operates on the regenerative Brayton cycle with reheating and intercooling. The back work ratio, the net work output, the thermal efficiency, the second-law efficiency, and the exergies at the exits of the combustion chamber and the regenerator are to be determined.

Assumptions 1 The air-standard assumptions are applicable. **2** Kinetic and potential energy changes are negligible. **3** Air is an ideal gas with variable specific heats.

Properties The gas constant of air is $R = 0.287 \text{ kJ/kg}\cdot\text{K}$.

Analysis (a) For this problem, we use the properties from EES software. Remember that for an ideal gas, enthalpy is a function of temperature only whereas entropy is functions of both temperature and pressure.

Optimum intercooling and reheating pressure is

$$P_2 = \sqrt{P_1 P_4} = \sqrt{(100)(1200)} = 346.4 \text{ kPa}$$

Process 1-2, 3-4: Compression

$$T_1 = 300 \text{ K} \longrightarrow h_1 = 300.43 \text{ kJ/kg}$$

$$\left. \begin{array}{l} T_1 = 300 \text{ K} \\ P_1 = 100 \text{ kPa} \end{array} \right\} s_1 = 5.7054 \text{ kJ/kg}\cdot\text{K}$$

$$\left. \begin{array}{l} P_2 = 346.4 \text{ kPa} \\ s_2 = s_1 = 5.7054 \text{ kJ/kg}\cdot\text{K} \end{array} \right\} h_{2s} = 428.79 \text{ kJ/kg}$$

$$\eta_C = \frac{h_{2s} - h_1}{h_2 - h_1} \longrightarrow 0.80 = \frac{428.79 - 300.43}{h_2 - 300.43} \longrightarrow h_2 = 460.88 \text{ kJ/kg}$$

$$T_3 = 350 \text{ K} \longrightarrow h_3 = 350.78 \text{ kJ/kg}$$

$$\left. \begin{array}{l} T_3 = 350 \text{ K} \\ P_3 = 346.4 \text{ kPa} \end{array} \right\} s_3 = 5.5040 \text{ kJ/kg}\cdot\text{K}$$

$$\left. \begin{array}{l} P_4 = 1200 \text{ kPa} \\ s_4 = s_3 = 5.5040 \text{ kJ/kg}\cdot\text{K} \end{array} \right\} h_{4s} = 500.42 \text{ kJ/kg}$$

$$\eta_C = \frac{h_{4s} - h_3}{h_4 - h_3} \longrightarrow 0.80 = \frac{500.42 - 350.78}{h_4 - 350.78} \longrightarrow h_4 = 537.83 \text{ kJ/kg}$$

Process 6-7, 8-9: Expansion

$$T_6 = 1400 \text{ K} \longrightarrow h_6 = 1514.9 \text{ kJ/kg}$$

$$\left. \begin{array}{l} T_6 = 1400 \text{ K} \\ P_6 = 1200 \text{ kPa} \end{array} \right\} s_6 = 6.6514 \text{ kJ/kg}\cdot\text{K}$$

$$\left. \begin{array}{l} P_7 = 346.4 \text{ kPa} \\ s_7 = s_6 = 6.6514 \text{ kJ/kg}\cdot\text{K} \end{array} \right\} h_{7s} = 1083.9 \text{ kJ/kg}$$

$$\eta_T = \frac{h_6 - h_7}{h_6 - h_{7s}} \longrightarrow 0.80 = \frac{1514.9 - h_7}{1514.9 - 1083.9} \longrightarrow h_7 = 1170.1 \text{ kJ/kg}$$

$$T_8 = 1300 \text{ K} \longrightarrow h_8 = 1395.6 \text{ kJ/kg}$$

$$\left. \begin{array}{l} T_8 = 1300 \text{ K} \\ P_8 = 346.4 \text{ kPa} \end{array} \right\} s_8 = 6.9196 \text{ kJ/kg}\cdot\text{K}$$

$$\left. \begin{array}{l} P_9 = 100 \text{ kPa} \\ s_9 = s_8 = 6.9196 \text{ kJ/kg}\cdot\text{K} \end{array} \right\} h_{9s} = 996.00 \text{ kJ/kg}$$

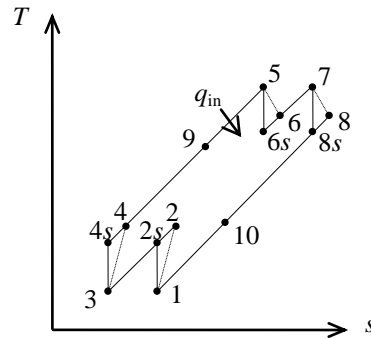

$$\eta_T = \frac{h_8 - h_9}{h_8 - h_{9s}} \longrightarrow 0.80 = \frac{1395.6 - h_9}{1395.6 - 996.00} \longrightarrow h_9 = 1075.9 \text{ kJ/kg}$$

Cycle analysis:

$$w_{C,\text{in}} = h_2 - h_1 + h_4 - h_3 = 460.88 - 300.43 + 537.83 - 350.78 = 347.50 \text{ kJ/kg}$$

$$w_{T,\text{out}} = h_6 - h_7 + h_8 - h_9 = 1514.9 - 1170.1 + 1395.6 - 1075.9 = 664.50 \text{ kJ/kg}$$

$$r_{\text{bw}} = \frac{w_{C,\text{in}}}{w_{T,\text{out}}} = \frac{347.50}{664.50} = \mathbf{0.523}$$

$$w_{\text{net}} = w_{T,\text{out}} - w_{C,\text{in}} = 664.50 - 347.50 = \mathbf{317.0 \text{ kJ/kg}}$$

Regenerator analysis:

$$\varepsilon_{\text{regen}} = \frac{h_9 - h_{10}}{h_9 - h_4} \longrightarrow 0.75 = \frac{1075.9 - h_{10}}{1075.9 - 537.83} \longrightarrow h_{10} = 672.36 \text{ kJ/kg}$$

$$\left. \begin{array}{l} h_{10} = 672.36 \text{ K} \\ P_{10} = 100 \text{ kPa} \end{array} \right\} s_{10} = 6.5157 \text{ kJ/kg} \cdot \text{K}$$

$$q_{\text{regen}} = h_9 - h_{10} = h_5 - h_4 \longrightarrow 1075.9 - 672.36 = h_5 - 537.83 \longrightarrow h_5 = 941.40 \text{ kJ/kg}$$

$$(b) \quad q_{\text{in}} = h_6 - h_5 = 1514.9 - 941.40 = 573.54 \text{ kJ/kg}$$

$$\eta_{\text{th}} = \frac{w_{\text{net}}}{q_{\text{in}}} = \frac{317.0}{573.54} = \mathbf{0.553}$$

(c) The second-law efficiency of the cycle is defined as the ratio of actual thermal efficiency to the maximum possible thermal efficiency (Carnot efficiency). The maximum temperature for the cycle can be taken to be the turbine inlet temperature. That is,

$$\eta_{\text{max}} = 1 - \frac{T_1}{T_6} = 1 - \frac{300 \text{ K}}{1400 \text{ K}} = 0.786$$

and

$$\eta_{II} = \frac{\eta_{\text{th}}}{\eta_{\text{max}}} = \frac{0.553}{0.786} = \mathbf{0.704}$$

(d) The exergies at the combustion chamber exit and the regenerator exit are

$$\begin{aligned} x_6 &= h_6 - h_0 - T_0(s_6 - s_0) \\ &= (1514.9 - 300.43) \text{ kJ/kg} - (300 \text{ K})(6.6514 - 5.7054) \text{ kJ/kg} \cdot \text{K} \\ &= \mathbf{930.7 \text{ kJ/kg}} \end{aligned}$$

$$\begin{aligned} x_{10} &= h_{10} - h_0 - T_0(s_{10} - s_0) \\ &= (672.36 - 300.43) \text{ kJ/kg} - (300 \text{ K})(6.5157 - 5.7054) \text{ kJ/kg} \cdot \text{K} \\ &= \mathbf{128.8 \text{ kJ/kg}} \end{aligned}$$

9-169 The thermal efficiency of a two-stage gas turbine with regeneration, reheating and intercooling to that of a three-stage gas turbine is to be compared.

Assumptions 1 The air standard assumptions are applicable. **2** Air is an ideal gas with constant specific heats at room temperature. **3** Kinetic and potential energy changes are negligible.

Properties The properties of air at room temperature are $c_p = 1.005 \text{ kJ/kg}\cdot\text{K}$ and $k = 1.4$ (Table A-2a).

Analysis

Two Stages:

The pressure ratio across each stage is

$$r_p = \sqrt{16} = 4$$

The temperatures at the end of compression and expansion are

$$T_c = T_{\min} r_p^{(k-1)/k} = (293 \text{ K})(4)^{0.4/1.4} = 435.4 \text{ K}$$

$$T_e = T_{\max} \left(\frac{1}{r_p} \right)^{(k-1)/k} = (1073 \text{ K}) \left(\frac{1}{4} \right)^{0.4/1.4} = 722.1 \text{ K}$$

The heat input and heat output are

$$q_{\text{in}} = 2c_p(T_{\max} - T_e) = 2(1.005 \text{ kJ/kg}\cdot\text{K})(1073 - 722.1) \text{ K} = 705.4 \text{ kJ/kg}$$

$$q_{\text{out}} = 2c_p(T_c - T_{\min}) = 2(1.005 \text{ kJ/kg}\cdot\text{K})(435.4 - 293) \text{ K} = 286.2 \text{ kJ/kg}$$

The thermal efficiency of the cycle is then

$$\eta_{\text{th}} = 1 - \frac{q_{\text{out}}}{q_{\text{in}}} = 1 - \frac{286.4}{705.4} = 0.5942 = \mathbf{59.4\%}$$

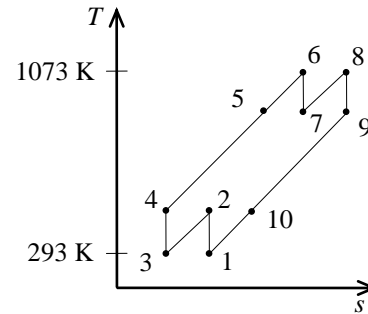

Three Stages:

The pressure ratio across each stage is

$$r_p = 16^{1/3} = 2.520$$

The temperatures at the end of compression and expansion are

$$T_c = T_{\min} r_p^{(k-1)/k} = (293 \text{ K})(2.520)^{0.4/1.4} = 381.5 \text{ K}$$

$$T_e = T_{\max} \left(\frac{1}{r_p} \right)^{(k-1)/k} = (1073 \text{ K}) \left(\frac{1}{2.520} \right)^{0.4/1.4} = 824.0 \text{ K}$$

The heat input and heat output are

$$q_{\text{in}} = 3c_p(T_{\max} - T_e) = 3(1.005 \text{ kJ/kg}\cdot\text{K})(1073 - 824.0) \text{ K} = 500.5 \text{ kJ/kg}$$

$$q_{\text{out}} = 3c_p(T_c - T_{\min}) = 3(1.005 \text{ kJ/kg}\cdot\text{K})(381.5 - 293) \text{ K} = 178.0 \text{ kJ/kg}$$

The thermal efficiency of the cycle is then

$$\eta_{\text{th}} = 1 - \frac{q_{\text{out}}}{q_{\text{in}}} = 1 - \frac{178.0}{500.5} = 0.6444 = \mathbf{64.4\%}$$

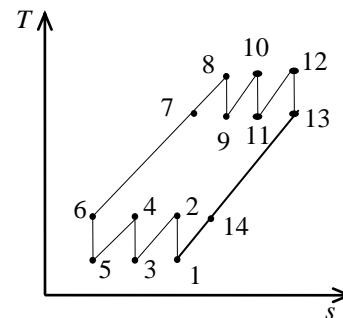

9-170E A pure jet engine operating on an ideal cycle is considered. The thrust force produced per unit mass flow rate is to be determined.

Assumptions 1 Steady operating conditions exist. **2** The air standard assumptions are applicable. **3** Air is an ideal gas with constant specific heats at room temperature. **4** The turbine work output is equal to the compressor work input.

Properties The properties of air at room temperature are $R = 0.3704 \text{ psia}\cdot\text{ft}^3/\text{lbm}\cdot\text{R}$ (Table A-1E), $c_p = 0.24 \text{ Btu}/\text{lbm}\cdot\text{R}$ and $k = 1.4$ (Table A-2Ea).

Analysis (a) We assume the aircraft is stationary and the air is moving towards the aircraft at a velocity of $V_1 = 1200 \text{ ft/s}$. Ideally, the air will leave the diffuser with a negligible velocity ($V_2 \cong 0$).

Diffuser:

$$\begin{aligned} \dot{E}_{\text{in}} - \dot{E}_{\text{out}} &= \Delta \dot{E}_{\text{system}}^{\phi_0 \text{ (steady)}} \longrightarrow \dot{E}_{\text{in}} = \dot{E}_{\text{out}} \\ h_1 + V_1^2/2 &= h_2 + V_2^2/2 \longrightarrow 0 = h_2 - h_1 + \frac{V_2^2 - V_1^2}{2} \\ 0 &= c_p(T_2 - T_1) - V_1^2/2 \\ T_2 &= T_1 + \frac{V_1^2}{2c_p} = 490 \text{ R} + \frac{(1200 \text{ ft/s})^2}{(2)(0.24 \text{ Btu}/\text{lbm}\cdot\text{R})} \left(\frac{1 \text{ Btu}/\text{lbm}}{25,037 \text{ ft}^2/\text{s}^2} \right) = 609.8 \text{ R} \\ P_2 &= P_1 \left(\frac{T_2}{T_1} \right)^{k/(k-1)} = (10 \text{ psia}) \left(\frac{609.8 \text{ R}}{490 \text{ R}} \right)^{1.4/0.4} = 21.5 \text{ psia} \end{aligned}$$

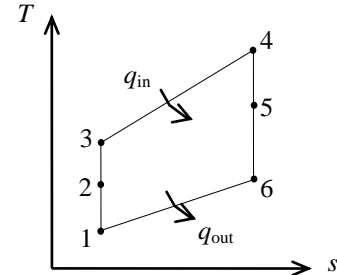

Compressor:

$$\begin{aligned} P_3 &= P_4 = (r_p)(P_2) = (9)(21.5 \text{ psia}) = 193.5 \text{ psia} \\ T_3 &= T_2 \left(\frac{P_3}{P_2} \right)^{(k-1)/k} = (609.8 \text{ R})(9)^{0.4/1.4} = 1142.4 \text{ R} \end{aligned}$$

Turbine:

$$w_{\text{comp,in}} = w_{\text{turb,out}} \longrightarrow h_3 - h_2 = h_4 - h_5 \longrightarrow c_p(T_3 - T_2) = c_p(T_4 - T_5)$$

$$\text{or } T_5 = T_4 - T_3 + T_2 = 1160 - 1142.4 + 609.8 = 627.4 \text{ R}$$

Nozzle:

$$T_6 = T_4 \left(\frac{P_6}{P_4} \right)^{(k-1)/k} = (1160 \text{ R}) \left(\frac{10 \text{ psia}}{193.5 \text{ psia}} \right)^{0.4/1.4} = 497.5 \text{ R}$$

$$\dot{E}_{\text{in}} - \dot{E}_{\text{out}} = \Delta \dot{E}_{\text{system}}^{\phi_0 \text{ (steady)}} \longrightarrow \dot{E}_{\text{in}} = \dot{E}_{\text{out}}$$

$$h_5 + V_5^2/2 = h_6 + V_6^2/2$$

$$0 = h_6 - h_5 + \frac{V_6^2 - V_5^2}{2} \longrightarrow 0 = c_p(T_6 - T_5) + V_6^2/2$$

$$\text{or, } V_6 = V_{\text{exit}} = \sqrt{(2)(0.24 \text{ Btu}/\text{lbm}\cdot\text{R})(627.4 - 497.5)\text{R} \left(\frac{25,037 \text{ ft}^2/\text{s}^2}{1 \text{ Btu}/\text{lbm}} \right)} = 1249 \text{ ft/s}$$

The specific impulse is then

$$\frac{F}{\dot{m}} = V_{\text{exit}} - V_{\text{inlet}} = 1249 - 1200 = \mathbf{49 \text{ m/s}}$$

9-171 The electricity and the process heat requirements of a manufacturing facility are to be met by a cogeneration plant consisting of a gas-turbine and a heat exchanger for steam production. The mass flow rate of the air in the cycle, the back work ratio, the thermal efficiency, the rate at which steam is produced in the heat exchanger, and the utilization efficiency of the cogeneration plant are to be determined.

Assumptions 1 The air-standard assumptions are applicable. **2** Kinetic and potential energy changes are negligible. **3** Air is an ideal gas with variable specific heats.

Analysis (a) For this problem, we use the properties of air from EES software. Remember that for an ideal gas, enthalpy is a function of temperature only whereas entropy is functions of both temperature and pressure.

Process 1-2: Compression

$$T_1 = 20^\circ\text{C} \longrightarrow h_1 = 293.5 \text{ kJ/kg}$$

$$\left. \begin{array}{l} T_1 = 20^\circ\text{C} \\ P_1 = 100 \text{ kPa} \end{array} \right\} s_1 = 5.682 \text{ kJ/kg} \cdot \text{K}$$

$$\left. \begin{array}{l} P_2 = 1000 \text{ kPa} \\ s_2 = s_1 = 5.682 \text{ kJ/kg} \cdot \text{K} \end{array} \right\} h_{2s} = 567.2 \text{ kJ/kg}$$

$$\eta_C = \frac{h_{2s} - h_1}{h_2 - h_1} \longrightarrow 0.86 = \frac{567.2 - 293.5}{h_2 - 293.5} \longrightarrow h_2 = 611.8 \text{ kJ/kg}$$

Process 3-4: Expansion

$$T_4 = 450^\circ\text{C} \longrightarrow h_4 = 738.5 \text{ kJ/kg}$$

$$\eta_T = \frac{h_3 - h_4}{h_3 - h_{4s}} \longrightarrow 0.88 = \frac{h_3 - 738.5}{h_3 - h_{4s}}$$

We cannot find the enthalpy at state 3 directly. However, using EES, we find

$$h_3 = 1262 \text{ kJ/kg}, T_3 = 913.2^\circ\text{C}, s_3 = 6.507 \text{ kJ/kg} \cdot \text{K}.$$

The solution by hand would require a trial-error approach. Also,

$$T_5 = 325^\circ\text{C} \longrightarrow h_5 = 605.4 \text{ kJ/kg}$$

The inlet water is compressed liquid at 15°C and at the saturation pressure of steam at 200°C (1555 kPa). This is not available in the tables but we can obtain it in EES. The alternative is to use saturated liquid enthalpy at the given temperature.

$$\left. \begin{array}{l} T_{w1} = 15^\circ\text{C} \\ P_1 = 1555 \text{ kPa} \end{array} \right\} h_{w1} = 64.47 \text{ kJ/kg}$$

$$\left. \begin{array}{l} T_{w2} = 200^\circ\text{C} \\ x_2 = 1 \end{array} \right\} h_{w2} = 2792 \text{ kJ/kg}$$

The net work output is

$$w_{C,\text{in}} = h_2 - h_1 = 611.8 - 293.5 = 318.2 \text{ kJ/kg}$$

$$w_{T,\text{out}} = h_3 - h_4 = 1262 - 738.5 = 523.4 \text{ kJ/kg}$$

$$w_{\text{net}} = w_{T,\text{out}} - w_{C,\text{in}} = 523.4 - 318.2 = 205.2 \text{ kJ/kg}$$

The mass flow rate of air is

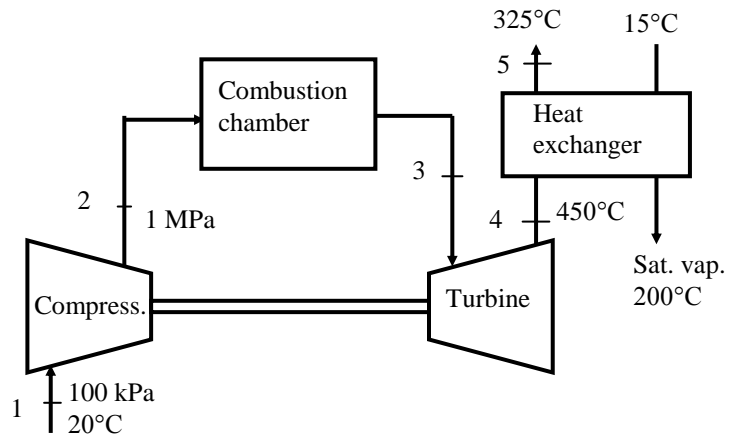

$$\dot{m}_a = \frac{\dot{W}_{\text{net}}}{w_{\text{net}}} = \frac{1500 \text{ kJ/s}}{205.2 \text{ kJ/kg}} = \mathbf{7.311 \text{ kg/s}}$$

(b) The back work ratio is

$$r_{\text{bw}} = \frac{w_{\text{C,in}}}{w_{\text{T,out}}} = \frac{318.2}{523.4} = \mathbf{0.608}$$

The rate of heat input and the thermal efficiency are

$$\dot{Q}_{\text{in}} = \dot{m}_a (h_3 - h_2) = (7.311 \text{ kg/s})(1262 - 611.8) \text{ kJ/kg} = 4753 \text{ kW}$$

$$\eta_{\text{th}} = \frac{\dot{W}_{\text{net}}}{\dot{Q}_{\text{in}}} = \frac{1500 \text{ kW}}{4753 \text{ kW}} = 0.3156 = \mathbf{31.6\%}$$

(c) An energy balance on the heat exchanger gives

$$\begin{aligned} \dot{m}_a (h_4 - h_5) &= \dot{m}_w (h_{w2} - h_{w1}) \\ (7.311 \text{ kg/s})(738.5 - 605.4) \text{ kJ/kg} &= \dot{m}_w (2792 - 64.47) \text{ kJ/kg} \longrightarrow \dot{m}_w = \mathbf{0.3569 \text{ kg/s}} \end{aligned}$$

(d) The heat supplied to the water in the heat exchanger (process heat) and the utilization efficiency are

$$\dot{Q}_p = \dot{m}_w (h_{w2} - h_{w1}) = (0.3569 \text{ kg/s})(2792 - 64.47) \text{ kJ/kg} = 973.5 \text{ kW}$$

$$\varepsilon_u = \frac{\dot{W}_{\text{net}} + \dot{Q}_p}{\dot{Q}_{\text{in}}} = \frac{1500 + 973.5}{4753 \text{ kW}} = 0.5204 = \mathbf{52.0\%}$$

The EES code for this problem is given next:

"GIVEN"

```
P_1=100 [kPa]
P_2=1000 [kPa]
T_1=20 [C]
T_4=450 [C]
T_hx_out=325 [C]
W_dot_net=1500 [kW]
T_w1=15 [C]
T_w2=200 [C]
eta_C=0.86
eta_T=0.88
```

"PROPERTIES"

```
Fluid$='Air'
h_1=enthalpy(Fluid$, T=T_1)
s_1=entropy(Fluid$, T=T_1, P=P_1)
h_2s=enthalpy(Fluid$, P=P_2, s=s_1)
h_2=h_1+(h_2s-h_1)/eta_C
h_4=enthalpy(Fluid$, T=T_4)
s_3=entropy(Fluid$, T=T_3, P=P_2)
h_3=enthalpy(Fluid$, T=T_3)
h_4s=enthalpy(Fluid$, P=P_1, s=s_3)
h_3=h_4+eta_T*(h_3-h_4s)
h_hx_out=enthalpy(Fluid$, T=T_hx_out)
FluidW$='Steam_iapws'
P_w=pressure(FluidW$, T=T_w2, x=1)
h_w1=enthalpy(FluidW$, T=T_w1, P=P_w)
h_w2=enthalpy(FluidW$, T=T_w2, x=1)
```

"ANALYSIS"

"(a)"

$$w_{C_in}=h_2-h_1$$

$$w_{T_out}=h_3-h_4$$

$$w_{net}=w_{T_out}-w_{C_in}$$

$$m_{dot_air}=W_{dot_net}/w_{net}$$

"(b)"

$$r_{bw}=w_{C_in}/w_{T_out}$$

$$Q_{dot_in}=m_{dot_air}*(h_3-h_2)$$

$$\eta_{th}=W_{dot_net}/Q_{dot_in}$$

"(c)"

$$m_{dot_steam}*(h_{w2}-h_{w1})=m_{dot_air}*(h_4-h_{hx_out})$$
 "energy balance on heat exchanger"

"(d)"

$$Q_{dot_hx}=m_{dot_steam}*(h_{w2}-h_{w1})$$

$$\eta_{utilization}=(W_{dot_net}+Q_{dot_hx})/Q_{dot_in}$$
 "utilization efficiency"

9-172 A turbojet aircraft flying is considered. The pressure of the gases at the turbine exit, the mass flow rate of the air through the compressor, the velocity of the gases at the nozzle exit, the propulsive power, and the propulsive efficiency of the cycle are to be determined.

Assumptions 1 The air-standard assumptions are applicable. **2** Potential energy changes are negligible. **3** Air is an ideal gas with variable specific heats.

Properties The gas constant of air is $R = 0.287 \text{ kJ/kg}\cdot\text{K}$ (Table A-1).

Analysis (a) For this problem, we use the properties from EES software. Remember that for an ideal gas, enthalpy is a function of temperature only whereas entropy is functions of both temperature and pressure.

Diffuser, Process 1-2:

$$T_1 = -35^\circ\text{C} \longrightarrow h_1 = 238.36 \text{ kJ/kg}$$

$$h_1 + \frac{V_1^2}{2} = h_2 + \frac{V_2^2}{2}$$

$$(238.36 \text{ kJ/kg}) + \frac{(1100/3.6 \text{ m/s})^2}{2} \left(\frac{1 \text{ kJ/kg}}{1000 \text{ m}^2/\text{s}^2} \right) = h_2 + \frac{(15 \text{ m/s})^2}{2} \left(\frac{1 \text{ kJ/kg}}{1000 \text{ m}^2/\text{s}^2} \right) \longrightarrow h_2 = 284.93 \text{ kJ/kg}$$

$$\left. \begin{array}{l} h_2 = 284.93 \text{ kJ/kg} \\ P_2 = 50 \text{ kPa} \end{array} \right\} s_2 = 5.8513 \text{ kJ/kg}\cdot\text{K}$$

Compressor, Process 2-3:

$$\left. \begin{array}{l} P_3 = 450 \text{ kPa} \\ s_3 = s_2 = 5.8513 \text{ kJ/kg}\cdot\text{K} \end{array} \right\} h_{3s} = 534.42 \text{ kJ/kg}$$

$$\eta_C = \frac{h_{3s} - h_2}{h_3 - h_2} \longrightarrow 0.83 = \frac{534.42 - 284.93}{h_3 - 284.93} \longrightarrow h_3 = 585.52 \text{ kJ/kg}$$

Turbine, Process 3-4:

$$T_4 = 950^\circ\text{C} \longrightarrow h_4 = 1305.2 \text{ kJ/kg}$$

$$h_3 - h_2 = h_4 - h_5 \longrightarrow 585.52 - 284.93 = 1305.2 - h_5 \longrightarrow h_5 = 1004.6 \text{ kJ/kg}$$

where the mass flow rates through the compressor and the turbine are assumed equal.

$$\eta_T = \frac{h_4 - h_5}{h_4 - h_{5s}} \longrightarrow 0.83 = \frac{1305.2 - 1004.6}{1305.2 - h_{5s}} \longrightarrow h_{5s} = 943.04 \text{ kJ/kg}$$

$$\left. \begin{array}{l} T_4 = 950^\circ\text{C} \\ P_4 = 450 \text{ kPa} \end{array} \right\} s_4 = 6.7725 \text{ kJ/kg}\cdot\text{K}$$

$$\left. \begin{array}{l} h_{5s} = 943.04 \text{ kJ/kg} \\ s_5 = s_4 = 6.7725 \text{ kJ/kg}\cdot\text{K} \end{array} \right\} P_5 = \mathbf{136.9 \text{ kPa}}$$

(b) The mass flow rate of the air through the compressor is

$$\dot{m} = \frac{\dot{W}_C}{h_3 - h_2} = \frac{800 \text{ kJ/s}}{(585.52 - 284.93) \text{ kJ/kg}} = \mathbf{2.661 \text{ kg/s}}$$

(c) *Nozzle, Process 5-6:*

$$\left. \begin{array}{l} h_5 = 1004.6 \text{ kJ/kg} \\ P_5 = 136.9 \text{ kPa} \end{array} \right\} s_5 = 6.8382 \text{ kJ/kg}\cdot\text{K}$$

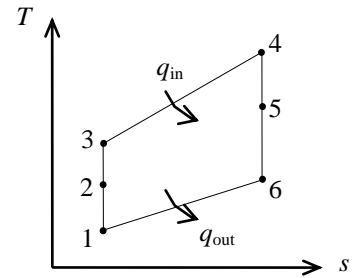

$$\left. \begin{aligned} P_6 &= 40 \text{ kPa} \\ s_6 &= s_5 = 6.8382 \text{ kJ/kg}\cdot\text{K} \end{aligned} \right\} h_{6s} = 713.12 \text{ kJ/kg}$$

$$\eta_N = \frac{h_5 - h_6}{h_5 - h_{6s}} \rightarrow 0.83 = \frac{1004.6 - h_6}{1004.6 - 713.12} \rightarrow h_6 = 762.68 \text{ kJ/kg}$$

$$h_5 + \frac{V_5^2}{2} = h_6 + \frac{V_6^2}{2}$$

$$(1004.6 \text{ kJ/kg}) + 0 = 762.68 \text{ kJ/kg} + \frac{V_6^2}{2} \left(\frac{1 \text{ kJ/kg}}{1000 \text{ m}^2/\text{s}^2} \right) \rightarrow V_6 = \mathbf{695.6 \text{ m/s}}$$

where the velocity at nozzle inlet is assumed zero.

(d) The propulsive power and the propulsive efficiency are

$$\dot{W}_p = \dot{m}(V_6 - V_1)V_1 = [2.661 \text{ kg/s}](695.6 \text{ m/s} - (1100/3.6) \text{ m/s})[(1100/3.6) \text{ m/s}] \left(\frac{1 \text{ kJ/kg}}{1000 \text{ m}^2/\text{s}^2} \right) = \mathbf{317.2 \text{ kW}}$$

$$\dot{Q}_{\text{in}} = \dot{m}(h_4 - h_3) = (2.661 \text{ kg/s})(1305.2 - 585.52) \text{ kJ/kg} = 1915 \text{ kW}$$

$$\eta_p = \frac{\dot{W}_p}{\dot{Q}_{\text{in}}} = \frac{317.2 \text{ kW}}{1915 \text{ kW}} = 0.1656 = \mathbf{16.6\%}$$

The EES code for this problem is given next:

"GIVEN"

Vel_1=1100[km/h]*Convert(km/h, m/s)

P_1=40 [kPa]; T_1=-35 [C]

P_2=50 [kPa]; Vel_2=15 [m/s]

P_4=450 [kPa]; T_4=950 [C]

W_dot=800 [kW]

eta_C=0.83; eta_T=0.83; eta_N=0.83

"ANALYSIS"

Fluid\$='Air'

"(a)"

"Diffuser, process 1-2"

h_1=enthalpy(Fluid\$, T=T_1)

h_2+Vel_2^2/2*Convert(m^2/s^2, kJ/kg)=h_1+Vel_1^2/2*Convert(m^2/s^2, kJ/kg) "energy balance"

"Compressor, process 2-3"

s_2=entropy(Fluid\$, h=h_2, P=P_2)

P_3=P_4

h_3s=enthalpy(Fluid\$, P=P_3, s=s_2)

h_3=h_2+(h_3s-h_2)/eta_C

"Turbine, process 4-5"

h_4=enthalpy(Fluid\$, T=T_4)

h_5=h_4+h_2-h_3 "turbine and compressor works are equal"

eta_T=(h_4-h_5)/(h_4-h_3s)

s_4=entropy(Fluid\$, T=T_4, P=P_4)

P_5=pressure(Fluid\$, h=h_5s, s=s_4)

"(b)"

m_dot=W_dot/(h_3-h_2)

"(c)"

"Nozzle, process 5-6"

Vel_5=0 "assumed"

s_5=entropy(Fluid\$, h=h_5, P=P_5)

P_6=P_1

$$h_{6s} = \text{enthalpy}(\text{Fluid}, P=P_6, s=s_5)$$

$$h_6 = h_5 - \eta_T (h_5 - h_{6s})$$

$$h_6 + \text{Vel}_6^2/2 * \text{Convert}(\text{m}^2/\text{s}^2, \text{kJ}/\text{kg}) = h_5 + \text{Vel}_5^2/2 * \text{Convert}(\text{m}^2/\text{s}^2, \text{kJ}/\text{kg}) \quad \text{"energy balance"}$$

"(d)"

"Cycle analysis"

$$W_{\text{dot}_P} = m_{\text{dot}} (\text{Vel}_6 - \text{Vel}_1) * \text{Vel}_1 * \text{Convert}(\text{m}^2/\text{s}^2, \text{kJ}/\text{kg})$$

$$Q_{\text{dot}_{in}} = m_{\text{dot}} (h_4 - h_3)$$

$$\eta_P = W_{\text{dot}_P} / Q_{\text{dot}_{in}}$$

9-173 The three processes of an air standard cycle are described. The cycle is to be shown on the P - v and T - s diagrams, and the expressions for back work ratio and the thermal efficiency are to be obtained.

Assumptions 1 The air-standard assumptions are applicable. **2** Kinetic and potential energy changes are negligible. **3** Air is an ideal gas with constant specific heats.

Analysis (a) The P - v and T - s diagrams for this cycle are as shown.

(b) The work of expansion is found by the first law for process 2-3:

$$q_{2-3} - w_{2-3} = \Delta u_{2-3}$$

$$q_{2-3} = 0 \text{ (isentropic process)}$$

$$w_{2-3} = -\Delta u_{2-3} = -C_v (T_3 - T_2)$$

$$w_{\text{exp}} = w_{2-3} = C_v (T_2 - T_3)$$

The compression work is found by

$$w_{\text{comp}} = -w_{3-1} = -\int_3^1 P dv = -P(v_1 - v_3) = R(T_3 - T_1)$$

The back work ratio is

$$\frac{w_{\text{comp}}}{w_{\text{exp}}} = \frac{C_v (T_3 - T_1)}{R(T_2 - T_3)} = \frac{C_v T_3 (1 - T_1/T_3)}{R T_3 (T_2/T_3 - 1)} = \frac{C_v (1 - T_1/T_3)}{R (T_2/T_3 - 1)}$$

Process 3-1 is constant pressure; therefore,

$$\frac{P_3 V_3}{T_3} = \frac{P_1 V_1}{T_1} \Rightarrow \frac{T_1}{T_3} = \frac{V_1}{V_3} = \frac{V_2}{V_3} = \frac{1}{r}$$

Process 2-3 is isentropic; therefore,

$$\frac{T_2}{T_3} = \left(\frac{V_2}{V_3} \right)^{k-1} = r^{k-1} \quad \text{and} \quad \frac{P_2}{P_3} = \left(\frac{V_3}{V_2} \right)^k = r^k$$

The back work ratio becomes ($C_v = R/(k-1)$)

$$\frac{w_{\text{comp}}}{w_{\text{exp}}} = (k-1) \frac{1 - \frac{1}{r}}{r^{k-1} - 1} = \frac{k-1}{r} \frac{r-1}{r^{k-1} - 1}$$

(c) Apply first law to the closed system for processes 1-2 and 3-1 to show:

$$q_{\text{in}} = C_v (T_2 - T_1)$$

$$q_{\text{out}} = C_p (T_3 - T_1)$$

The cycle thermal efficiency is given by

$$\eta_{\text{th}} = 1 - \frac{q_{\text{out}}}{q_{\text{in}}} = 1 - \frac{C_p (T_3 - T_1)}{C_v (T_2 - T_1)} = 1 - k \frac{T_1 (T_3/T_1 - 1)}{T_1 (T_2/T_1 - 1)}$$

Process 1-2 is constant volume; therefore,

$$\frac{P_2 V_2}{T_2} = \frac{P_1 V_1}{T_1} \Rightarrow \frac{T_2}{T_1} = \frac{P_2}{P_1} = \frac{P_2}{P_3} = r^k$$

The efficiency becomes

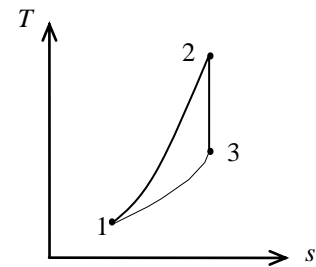
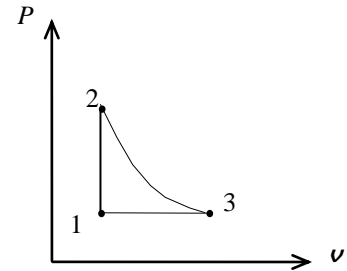

$$\eta_{th} = 1 - k \frac{r-1}{r^k - 1}$$

(d) Determine the value of the back work ratio and efficiency as r goes to unity.

$$\frac{W_{comp}}{W_{exp}} = (k-1) \frac{1 - \frac{1}{r}}{r^{k-1} - 1} = \frac{k-1}{r} \frac{r-1}{r^{k-1} - 1}$$

$$\lim_{r \rightarrow 1} \frac{W_{comp}}{W_{exp}} = (k-1) \left\{ \lim_{r \rightarrow 1} \frac{r-1}{r^k - r} \right\} = (k-1) \left\{ \lim_{r \rightarrow 1} \frac{1}{kr^{k-1} - 1} \right\}$$

$$\lim_{r \rightarrow 1} \frac{W_{comp}}{W_{exp}} = (k-1) \left\{ \frac{1}{k-1} \right\} = 1$$

$$\eta_{th} = 1 - k \frac{r-1}{r^k - 1}$$

$$\lim_{r \rightarrow 1} \eta_{th} = 1 - k \left\{ \lim_{r \rightarrow 1} \frac{r-1}{r^k - 1} \right\} = 1 - k \left\{ \lim_{r \rightarrow 1} \frac{1}{kr^{k-1}} \right\}$$

$$\lim_{r \rightarrow 1} \eta_{th} = 1 - k \left\{ \frac{1}{k} \right\} = 0$$

These results show that if there is no compression (i.e. $r = 1$), there can be no expansion and no net work will be done even though heat may be added to the system.

9-174 An ideal regenerative Brayton cycle is considered. The pressure ratio that maximizes the thermal efficiency of the cycle is to be determined, and to be compared with the pressure ratio that maximizes the cycle net work.

Analysis Using the isentropic relations, the temperatures at the compressor and turbine exit can be expressed as

$$T_2 = T_1 \left(\frac{P_2}{P_1} \right)^{(k-1)/k} = T_1 (r_p)^{(k-1)/k}$$

$$T_4 = T_3 \left(\frac{P_4}{P_3} \right)^{(k-1)/k} = T_3 \left(\frac{1}{r_p} \right)^{(k-1)/k} = T_3 r_p^{-(k-1)/k}$$

Then,

$$q_{\text{in}} = h_3 - h_5 = c_p (T_3 - T_5) = c_p (T_3 - T_4) = c_p T_3 (1 - r_p^{-(k-1)/k})$$

$$q_{\text{out}} = h_6 - h_1 = c_p (T_6 - T_1) = c_p (T_2 - T_1) = c_p T_1 (r_p^{(k-1)/k} - 1)$$

$$w_{\text{net}} = q_{\text{in}} - q_{\text{out}} = c_p (T_3 - T_3 r_p^{(1-k)/k} - T_1 r_p^{(k-1)/k} + T_1)$$

To maximize the net work, we must have

$$\frac{\partial w_{\text{net}}}{\partial r_p} = c_p \left(-\frac{1-k}{k} T_3 r_p^{(1-k)/k} - 1 - \frac{k-1}{k} T_1 r_p^{(k-1)/k} - 1 \right) = 0$$

Solving for r_p gives

$$r_p = \left(\frac{T_1}{T_3} \right)^{k/2(1-k)}$$

Similarly,

$$\eta_{\text{th}} = 1 - \frac{q_{\text{out}}}{q_{\text{in}}} = 1 - \frac{c_p T_1 (r_p^{(k-1)/k} - 1)}{c_p T_3 (1 - r_p^{-(k-1)/k})}$$

which simplifies to

$$\eta_{\text{th}} = 1 - \frac{T_1}{T_3} r_p^{(k-1)/k}$$

When $r_p = 1$, the thermal efficiency becomes $\eta_{\text{th}} = 1 - T_1/T_3$, which is the Carnot efficiency. Therefore, the efficiency is a maximum when $r_p = 1$, and must decrease as r_p increases for the fixed values of T_1 and T_3 . Note that the compression ratio cannot be less than 1, and the factor

$$r_p^{(k-1)/k}$$

is always greater than 1 for $r_p > 1$. Also note that the net work $w_{\text{net}} = 0$ for $r_p = 1$. This being the case, the pressure ratio for maximum thermal efficiency, which is $r_p = 1$, is always less than the pressure ratio for maximum work.

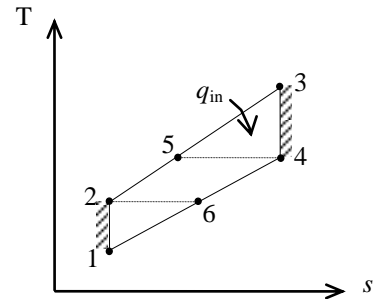



9-175 The effect of variable specific heats on the thermal efficiency of the ideal Otto cycle using air as the working fluid is to be investigated. The percentage of error involved in using constant specific heat values at room temperature for different combinations of compression ratio and maximum cycle temperature is to be determined.

Analysis Using EES, the problem is solved as follows:

```
Procedure ConstPropResult(T[1],P[1],r_comp,T[3]:Eta_th_ConstProp,Eta_th_easy)
```

```
"For Air:"
```

```
C_V = 0.718 [kJ/kg-K]
```

```
k = 1.4
```

```
T2 = T[1]*r_comp^(k-1)
```

```
P2 = P[1]*r_comp^k
```

```
q_in_23 = C_V*(T[3]-T2)
```

```
T4 = T[3]*(1/r_comp)^(k-1)
```

```
q_out_41 = C_V*(T4-T[1])
```

```
Eta_th_ConstProp = (1-q_out_41/q_in_23)*Convert(, %) "[%]"
```

```
"The Easy Way to calculate the constant property Otto cycle efficiency is:"
```

```
Eta_th_easy = (1 - 1/r_comp^(k-1))*Convert(, %) "[%]"
```

```
END
```

```
"Input Data"
```

```
T[1]=300 [K]
```

```
P[1]=100 [kPa]
```

```
"T[3] = 1000 [K]"
```

```
r_comp = 12
```

```
"Process 1-2 is isentropic compression"
```

```
s[1]=entropy(air,T=T[1],P=P[1])
```

```
s[2]=s[1]
```

```
T[2]=temperature(air, s=s[2], P=P[2])
```

```
P[2]*v[2]/T[2]=P[1]*v[1]/T[1]
```

```
P[1]*v[1]=R*T[1]
```

```
R=0.287 [kJ/kg-K]
```

```
V[2] = V[1]/ r_comp
```

```
"Conservation of energy for process 1 to 2"
```

```
q_12 - w_12 = DELTAu_12
```

```
q_12 = 0 "isentropic process"
```

```
DELTAu_12=intenergy(air,T=T[2])-intenergy(air,T=T[1])
```

```
"Process 2-3 is constant volume heat addition"
```

```
v[3]=v[2]
```

```
s[3]=entropy(air, T=T[3], P=P[3])
```

```
P[3]*v[3]=R*T[3]
```

```
"Conservation of energy for process 2 to 3"
```

```
q_23 - w_23 = DELTAu_23
```

```
w_23 = 0 "constant volume process"
```

```
DELTAu_23=intenergy(air,T=T[3])-intenergy(air,T=T[2])
```

```
"Process 3-4 is isentropic expansion"
```

```
s[4]=s[3]
```

```
s[4]=entropy(air,T=T[4],P=P[4])
```

```
P[4]*v[4]=R*T[4]
```

```
"Conservation of energy for process 3 to 4"
```

```
q_34 - w_34 = DELTAu_34
```

```
q_34 = 0 "isentropic process"
```

```
DELTAu_34=intenergy(air,T=T[4])-intenergy(air,T=T[3])
```

```
"Process 4-1 is constant volume heat rejection"
```

```
V[4] = V[1]
```

```
"Conservation of energy for process 4 to 1"
```

```
q_41 - w_41 = DELTAu_41
```

```
w_41 = 0 "constant volume process"
```

```

DELTAu_41=intenergy(air,T=T[1])-intenergy(air,T=T[4])
q_in_total=q_23
q_out_total = -q_41
w_net = w_12+w_23+w_34+w_41
Eta_th=w_net/q_in_total*Convert(, %) "Thermal efficiency, in percent"

```

```

Call ConstPropResult(T[1],P[1],r_comp,T[3]:Eta_th_ConstProp,Eta_th_easy)
PerCentError = ABS(Eta_th - Eta_th_ConstProp)/Eta_th*Convert(, %) "[%]"

```

PerCentError [%]	r_{comp}	η_{th} [%]	$\eta_{\text{th,ConstProp}}$ [%]	$\eta_{\text{th,easy}}$ [%]	T_3 [K]
3.604	12	60.8	62.99	62.99	1000
6.681	12	59.04	62.99	62.99	1500
9.421	12	57.57	62.99	62.99	2000
11.64	12	56.42	62.99	62.99	2500

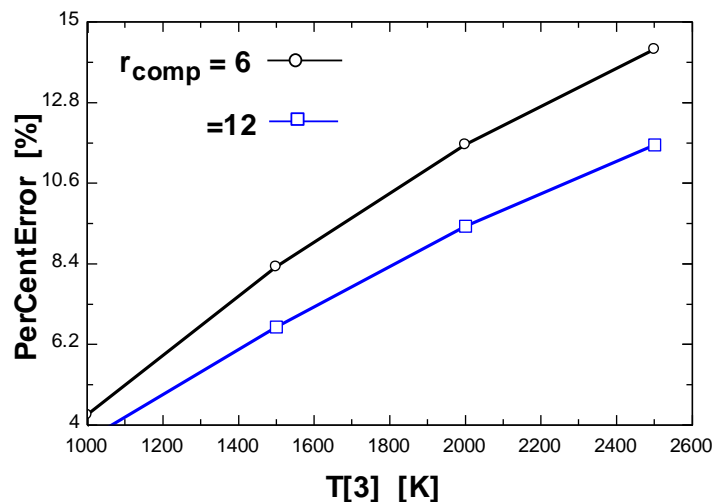
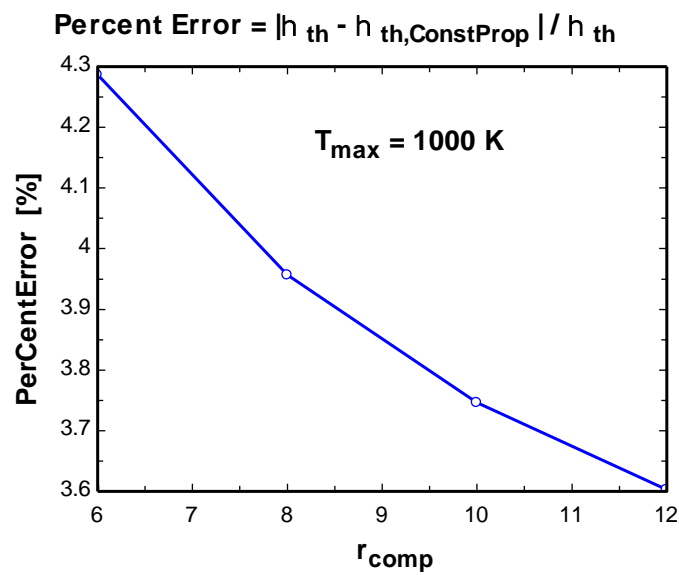



9-176 The effects of pressure ratio, maximum cycle temperature, and compressor and turbine inefficiencies on the net work output per unit mass and the thermal efficiency of a simple Brayton cycle with air as the working fluid is to be investigated. Constant specific heats at room temperature are to be used.

Analysis Using EES, the problem is solved as follows:

"Given"

```
r_p=5 "r_p=P2/P1=P3/P4"
T1=300 [K]
T3=800 [K]
eta_C=0.80
eta_T=0.80
```

"Properties"

```
Fluid$='air'
c_p=CP(Fluid$, T=T)
c_v=CV(Fluid$, T=T)
T=300 [K]
k=c_p/c_v
```

"Analysis"

```
T2s=T1*r_p^((k-1)/k)
T4s=T3*(1/r_p)^((k-1)/k)
eta_C=(T2s-T1)/(T2-T1)
eta_T=(T3-T4)/(T3-T4s)
q_in=c_p*(T3-T2)
q_out=c_p*(T4-T1)
w_net_out=q_in-q_out
eta_th=w_net_out/q_in
```

T_3	$W_{\text{net,out}}$	η_{th}
800	17.07	0.06044
900	46.7	0.122
1000	76.32	0.1579
1100	105.9	0.1815
1200	135.6	0.1981
1300	165.2	0.2105
1400	194.8	0.2201
1500	224.4	0.2277
1600	254.1	0.2339

$r_p = 5, \eta_C = \eta_T = 0.80$

η_C and η_T	$W_{net,out}$	η_{th}
0.8	17.07	0.06044
0.82	28.36	0.09855
0.84	39.39	0.1345
0.86	50.19	0.1686
0.88	60.76	0.2009
0.9	71.13	0.2318
0.92	81.31	0.2614
0.94	91.3	0.2897
0.96	101.1	0.3169
0.98	110.8	0.3432
1	120.3	0.3686

$r_p = 5, T_3 = 800 \text{ K}$

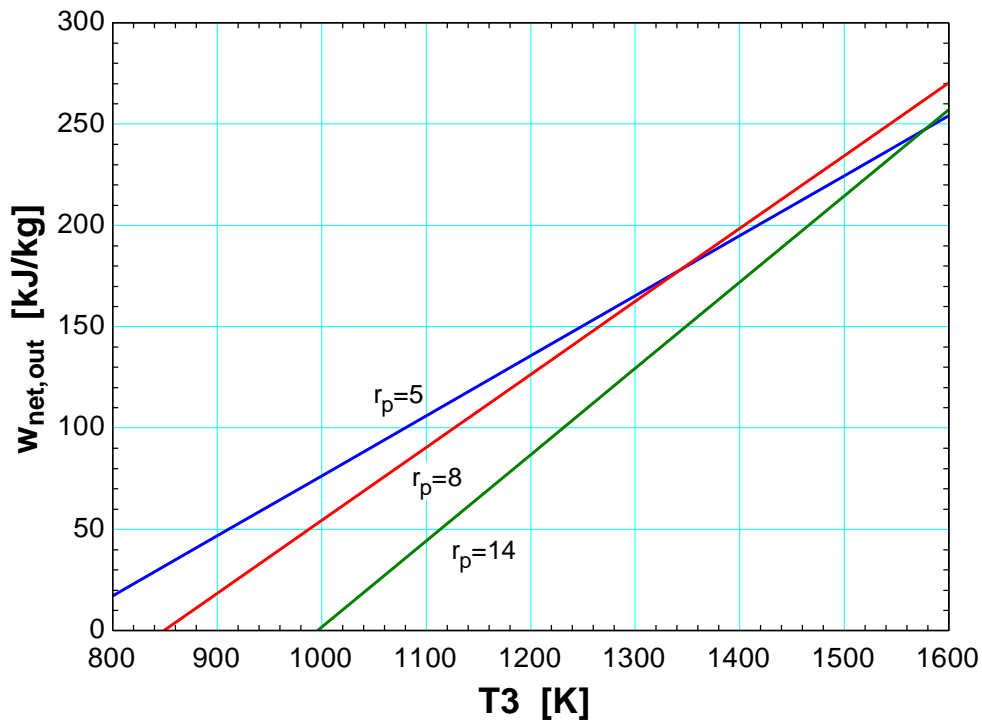

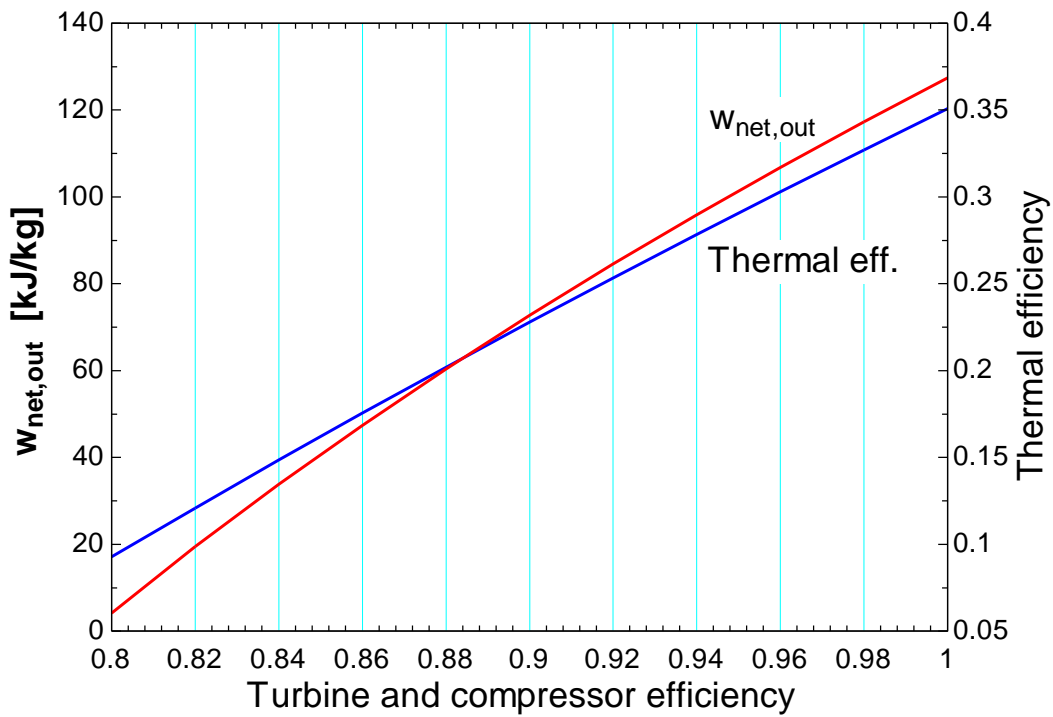
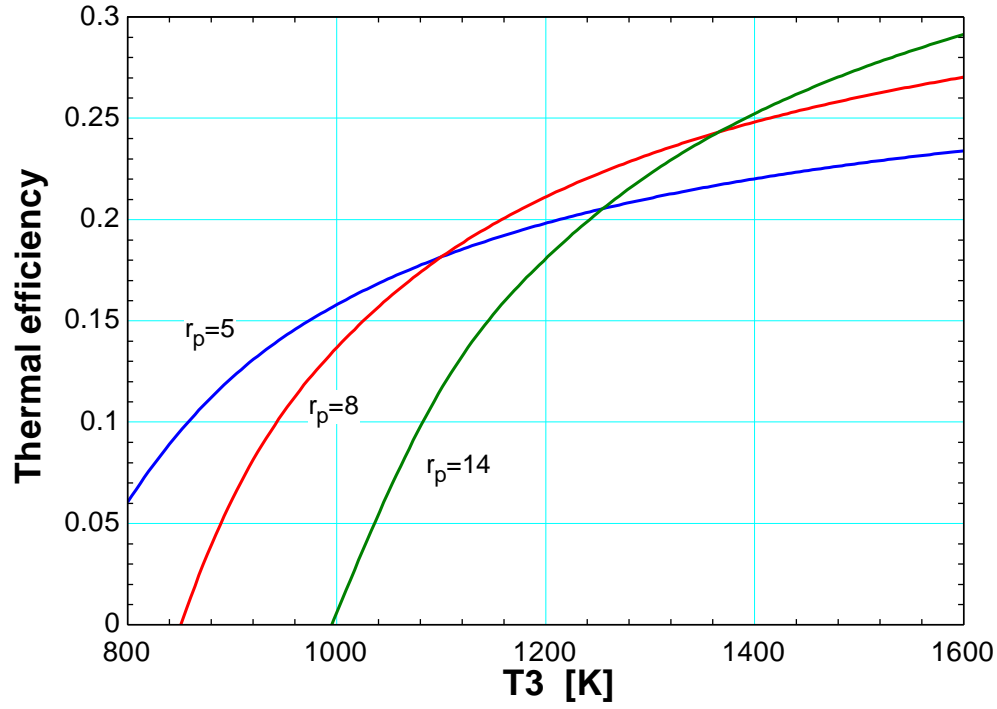



9-177 The effects of pressure ratio, maximum cycle temperature, and compressor and turbine efficiencies on the net work output per unit mass and the thermal efficiency of a simple Brayton cycle with air as the working fluid is to be investigated. Variable specific heats are to be used.

Analysis Using EES, the problem is solved as follows:

"Input data - from diagram window"

```
{P_ratio = 8}
{T[1] = 300 [K]
P[1]= 100 [kPa]
T[3] = 800 [K]
m_dot = 1 [kg/s]
Eta_c = 75/100
Eta_t = 82/100}
```

"Inlet conditions"

```
h[1]=ENTHALPY(Air,T=T[1])
s[1]=ENTROPY(Air,T=T[1],P=P[1])
```

"Compressor analysis"

```
s_s[2]=s[1] "For the ideal case the entropies are constant across the compressor"
P_ratio=P[2]/P[1]"Definition of pressure ratio - to find P[2]"
T_s[2]=TEMPERATURE(Air,s=s_s[2],P=P[2]) "T_s[2] is the isentropic value of T[2] at compressor exit"
h_s[2]=ENTHALPY(Air,T=T_s[2])
Eta_c =(h_s[2]-h[1])/(h[2]-h[1]) "Compressor adiabatic efficiency; Eta_c = W_dot_c_ideal/W_dot_c_actual. "
m_dot*h[1] +W_dot_c=m_dot*h[2] "SSSF First Law for the actual compressor, assuming: adiabatic, ke=pe=0"
"External heat exchanger analysis"
P[3]=P[2]"process 2-3 is SSSF constant pressure"
h[3]=ENTHALPY(Air,T=T[3])
m_dot*h[2] + Q_dot_in= m_dot*h[3]"SSSF First Law for the heat exchanger, assuming W=0, ke=pe=0"
```

"Turbine analysis"

```
s[3]=ENTROPY(Air,T=T[3],P=P[3])
s_s[4]=s[3] "For the ideal case the entropies are constant across the turbine"
P_ratio= P[3] /P[4]
T_s[4]=TEMPERATURE(Air,s=s_s[4],P=P[4]) "Ts[4] is the isentropic value of T[4] at turbine exit"
h_s[4]=ENTHALPY(Air,T=T_s[4]) "Eta_t = W_dot_t /Wts_dot turbine adiabatic efficiency, Wts_dot > W_dot_t"
Eta_t=(h[3]-h[4])/(h[3]-h_s[4])
m_dot*h[3] = W_dot_t + m_dot*h[4] "SSSF First Law for the actual compressor, assuming: adiabatic, ke=pe=0"
```

"Cycle analysis"

```
W_dot_net=W_dot_t-W_dot_c"Definition of the net cycle work, kW"
Eta=W_dot_net/Q_dot_in"Cycle thermal efficiency"
Bwr=W_dot_c/W_dot_t "Back work ratio"
"The following state points are determined only to produce a T-s plot"
T[2]=temperature('air',h=h[2])
T[4]=temperature('air',h=h[4])
s[2]=entropy(air,T=T[2],P=P[2])
s[4]=entropy(air,T=T[4],P=P[4])
```

Bwr	η	P_{ratio}	W_c [kW]	W_{net} [kW]	W_t [kW]	Q_{in} [kW]
0.5229	0.1	2	1818	1659	3477	16587
0.6305	0.1644	4	4033	2364	6396	14373
0.7038	0.1814	6	5543	2333	7876	12862
0.7611	0.1806	8	6723	2110	8833	11682
0.8088	0.1702	10	7705	1822	9527	10700
0.85	0.1533	12	8553	1510	10063	9852
0.8864	0.131	14	9304	1192	10496	9102
0.9192	0.1041	16	9980	877.2	10857	8426
0.9491	0.07272	18	10596	567.9	11164	7809
0.9767	0.03675	20	11165	266.1	11431	7241

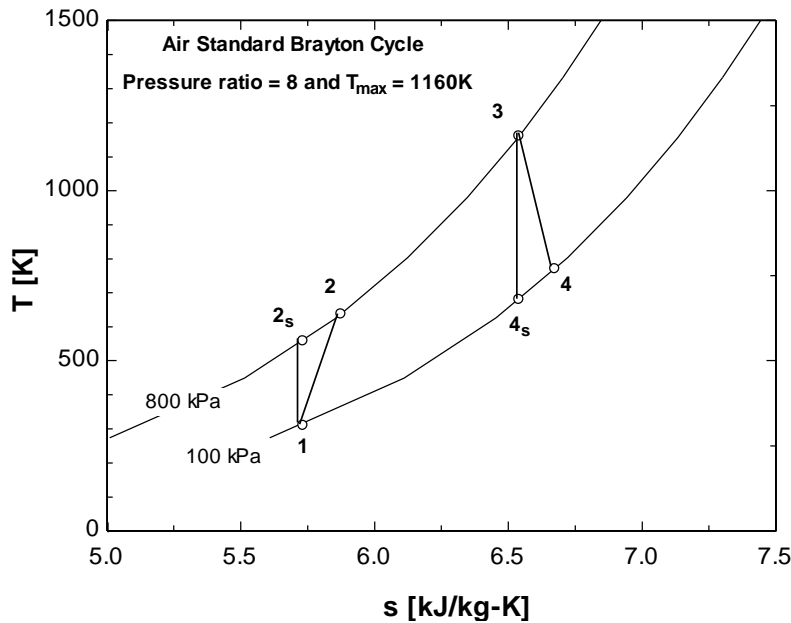
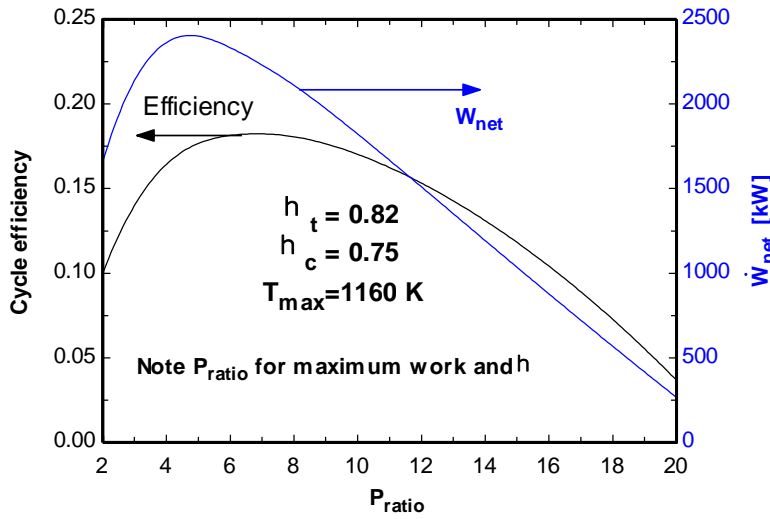



9-178 The effects of pressure ratio, maximum cycle temperature, and compressor and turbine efficiencies on the net work output per unit mass and the thermal efficiency of a simple Brayton cycle with helium as the working fluid is to be investigated.

Analysis Using EES, the problem is solved as follows:

```

Function hFunc(WorkFluid$,T,P)
"The EES functions treat helium as a real gas; thus, T and P are needed for helium's enthalpy."
IF WorkFluid$ = 'Air' then hFunc:=enthalpy(Air,T=T) ELSE
    hFunc:= enthalpy(Helium,T=T,P=P)
endif
END
Procedure EtaCheck(Eta_th:EtaError$)
If Eta_th < 0 then EtaError$ = 'Why are the net work done and efficiency < 0?' Else EtaError$ = "
END
"Input data - from diagram window"
{P_ratio = 8}
{T[1] = 300 [K]}
{P[1]= 100 [kPa]}
{T[3] = 800 [K]}
m_dot = 1 [kg/s]
Eta_c = 0.8
Eta_t = 0.8
WorkFluid$ = 'Helium'}
"Inlet conditions"
h[1]=hFunc(WorkFluid$,T[1],P[1])
s[1]=ENTROPY(WorkFluid$,T=T[1],P=P[1])
"Compressor analysis"
s_s[2]=s[1] "For the ideal case the entropies are constant across the compressor"
P_ratio=P[2]/P[1]"Definition of pressure ratio - to find P[2]"
T_s[2]=TEMPERATURE(WorkFluid$,s=s_s[2],P=P[2]) "T_s[2] is the isentropic value of T[2] at compressor exit"
h_s[2]=hFunc(WorkFluid$,T_s[2],P[2])
Eta_c =(h_s[2]-h[1])/(h[2]-h[1]) "Compressor adiabatic efficiency; Eta_c = W_dot_c_ideal/W_dot_c_actual. "
m_dot*h[1] +W_dot_c=m_dot*h[2] "SSSF First Law for the actual compressor, assuming: adiabatic, ke=pe=0"
"External heat exchanger analysis"
P[3]=P[2]"process 2-3 is SSSF constant pressure"
h[3]=hFunc(WorkFluid$,T[3],P[3])
m_dot*h[2] + Q_dot_in= m_dot*h[3]"SSSF First Law for the heat exchanger, assuming W=0, ke=pe=0"
"Turbine analysis"
s[3]=ENTROPY(WorkFluid$,T=T[3],P=P[3])
s_s[4]=s[3] "For the ideal case the entropies are constant across the turbine"
P_ratio= P[3] /P[4]
T_s[4]=TEMPERATURE(WorkFluid$,s=s_s[4],P=P[4]) "Ts[4] is the isentropic value of T[4] at turbine exit"
h_s[4]=hFunc(WorkFluid$,T_s[4],P[4]) "Eta_t = W_dot_t /Wts_dot turbine adiabatic efficiency, Wts_dot >
W_dot_t"
Eta_t=(h[3]-h[4])/(h[3]-h_s[4])
m_dot*h[3] = W_dot_t + m_dot*h[4] "SSSF First Law for the actual compressor, assuming: adiabatic, ke=pe=0"
"Cycle analysis"
W_dot_net=W_dot_t-W_dot_c"Definition of the net cycle work, kW"
Eta_th=W_dot_net/Q_dot_in"Cycle thermal efficiency"
Call EtaCheck(Eta_th:EtaError$)
Bwr=W_dot_c/W_dot_t "Back work ratio"
"The following state points are determined only to produce a T-s plot"
T[2]=temperature(air,h=h[2])
T[4]=temperature(air,h=h[4])
s[2]=entropy(air,T=T[2],P=P[2])
s[4]=entropy(air,T=T[4],P=P[4])

```

Bwr	η	P_{ratio}	W_c [kW]	W_{net} [kW]	W_t [kW]	Q_{in} [kW]
0.5229	0.1	2	1818	1659	3477	16587
0.6305	0.1644	4	4033	2364	6396	14373
0.7038	0.1814	6	5543	2333	7876	12862
0.7611	0.1806	8	6723	2110	8833	11682
0.8088	0.1702	10	7705	1822	9527	10700
0.85	0.1533	12	8553	1510	10063	9852
0.8864	0.131	14	9304	1192	10496	9102
0.9192	0.1041	16	9980	877.2	10857	8426
0.9491	0.07272	18	10596	567.9	11164	7809
0.9767	0.03675	20	11165	266.1	11431	7241

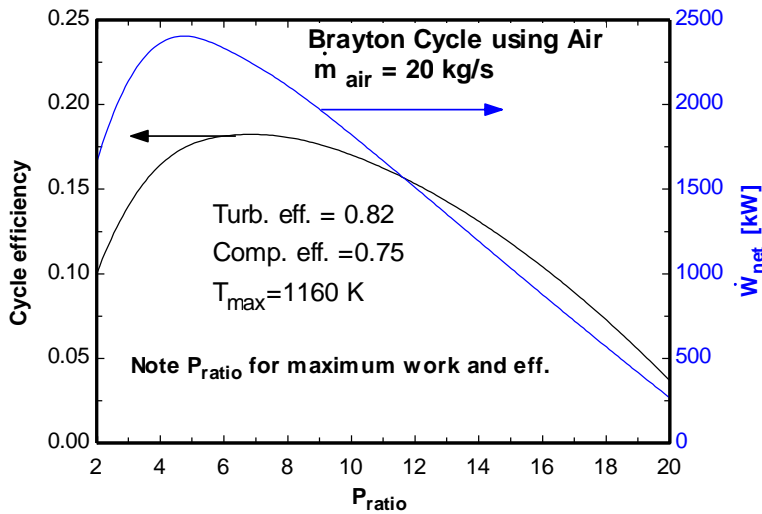
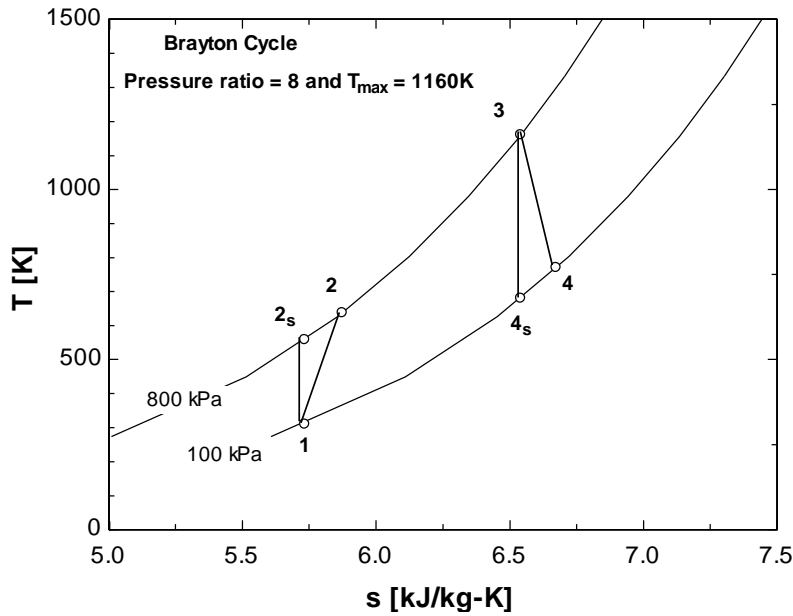



9-179 The effects of pressure ratio, maximum cycle temperature, regenerator effectiveness, and compressor and turbine efficiencies on the net work output per unit mass and the thermal efficiency of a regenerative Brayton cycle with air as the working fluid is to be investigated. Constant specific heats at room temperature are to be used.

Analysis Using EES, the problem is solved as follows:

"Input data for air"

$$C_P = 1.005 \text{ [kJ/kg-K]}$$

$$k = 1.4$$

"Other Input data from the diagram window"

$$T[3] = 1200 \text{ [K]}$$

$$Pratio = 10$$

$$T[1] = 300 \text{ [K]}$$

$$P[1] = 100 \text{ [kPa]}$$

$$Eta_{reg} = 1.0$$

$$Eta_c = 0.8 \text{ "Compressor isentropic efficiency"}$$

$$Eta_t = 0.9 \text{ "Turbine isentropic efficiency"}$$

"Isentropic Compressor analysis"

$$T_{s[2]} = T[1] * Pratio^{(k-1)/k}$$

$$P[2] = Pratio * P[1]$$

"T_{s[2]} is the isentropic value of T[2] at compressor exit"

$$Eta_c = w_{compisen} / w_{comp}$$

"compressor adiabatic efficiency, $W_{comp} > W_{compisen}$ "

"Conservation of energy for the compressor for the isentropic case:

$$e_{in} - e_{out} = \Delta e = 0 \text{ for steady-flow}$$

$$w_{compisen} = C_P * (T_{s[2]} - T[1])$$

"Actual compressor analysis:"

$$w_{comp} = C_P * (T[2] - T[1])$$

"External heat exchanger analysis"

"SSSF First Law for the heat exchanger, assuming $W=0$, $ke=pe=0$

$$e_{in} - e_{out} = \Delta e_{cv} = 0 \text{ for steady flow}$$

$$q_{in,noreg} = C_P * (T[3] - T[2])$$

$$P[3] = P[2] \text{ "process 2-3 is SSSF constant pressure"}$$

"Turbine analysis"

$$P[4] = P[3] / Pratio$$

$$T_{s[4]} = T[3] * (1/Pratio)^{(k-1)/k}$$

"T_{s[4]} is the isentropic value of T[4] at turbine exit"

$$Eta_t = w_{turb} / w_{turbisen} \text{ "turbine adiabatic efficiency, } w_{turbisen} > w_{turb} \text{"}$$

"SSSF First Law for the isentropic turbine, assuming: adiabatic, $ke=pe=0$

$$e_{in} - e_{out} = \Delta e_{cv} = 0 \text{ for steady-flow}$$

$$w_{turbisen} = C_P * (T[3] - T_{s[4]})$$

"Actual Turbine analysis:"

$$w_{turb} = C_P * (T[3] - T[4])$$

"Cycle analysis"

$$w_{net} = w_{turb} - w_{comp}$$

$$Eta_{th,noreg} = w_{net} / q_{in,noreg} * \text{Convert}(, \%) \text{ "[%]"} \text{ "Cycle thermal efficiency"}$$

$$Bwr = w_{comp} / w_{turb} \text{ "Back work ratio"}$$

"With the regenerator the heat added in the external heat exchanger is"

$$q_{in,withreg} = C_P * (T[3] - T[5])$$

$$P[5] = P[2]$$

"The regenerator effectiveness gives $h[5]$ and thus $T[5]$ as:"

$$\text{Eta_reg} = (T[5]-T[2])/(T[4]-T[2])$$

"Energy balance on regenerator gives $h[6]$ and thus $T[6]$ as:"

$$T[2] + T[4] = T[5] + T[6]$$

$$P[6] = P[4]$$

"Cycle thermal efficiency with regenerator"

$$\text{Eta_th_withreg} = w_net / q_in_withreg * \text{Convert}(, \%) \text{ "[\%]"}$$

η_c	η_t	$\eta_{th,noreg}$ [%]	$\eta_{th,withreg}$ [%]	$q_{in,noreg}$ [kJ/kg]	$q_{in,withreg}$ [kJ/kg]	W_{net} [kJ/kg]
0.6	0.9	14.76	13.92	510.9	541.6	75.4
0.65	0.9	20.35	20.54	546.8	541.6	111.3
0.7	0.9	24.59	26.22	577.5	541.6	142
0.75	0.9	27.91	31.14	604.2	541.6	168.6
0.8	0.9	30.59	35.44	627.5	541.6	192
0.85	0.9	32.79	39.24	648	541.6	212.5
0.9	0.9	34.64	42.61	666.3	541.6	230.8



9-180 The effects of pressure ratio, maximum cycle temperature, regenerator effectiveness, and compressor and turbine efficiencies on the net work output per unit mass and the thermal efficiency of a regenerative Brayton cycle with air as the working fluid is to be investigated. Variable specific heats are to be used.

Analysis Using EES, the problem is solved as follows:

```
"Input data"
"Input data from the diagram window"
{T[3] = 1200 [K]
Pratio = 10
T[1] = 300 [K]
P[1]= 100 [kPa]
Eta_reg = 1.0
Eta_c =0.8 "Compressor isentropic efficiency"
Eta_t =0.9 "Turbine isentropic efficiency"}

"Isentropic Compressor analysis"
s[1]=ENTROPY(Air,T=T[1],P=P[1])
s_s[2]=s[1] "For the ideal case the entropies are constant across the compressor"
P[2] = Pratio*P[1]
s_s[2]=ENTROPY(Air,T=T_s[2],P=P[2])
"T_s[2] is the isentropic value of T[2] at compressor exit"
Eta_c = w_compisen/w_comp
"compressor adiabatic efficiency, W_comp > W_compisen"

"Conservation of energy for the compressor for the isentropic case:
e_in - e_out = DELTAe=0 for steady-flow"
h[1] + w_compisen = h_s[2]
h[1]=ENTHALPY(Air,T=T[1])
h_s[2]=ENTHALPY(Air,T=T_s[2])

"Actual compressor analysis:"
h[1] + w_comp = h[2]
h[2]=ENTHALPY(Air,T=T[2])
s[2]=ENTROPY(Air,T=T[2], P=P[2])

"External heat exchanger analysis"
"SSSF First Law for the heat exchanger, assuming W=0, ke=pe=0
e_in - e_out =DELTAe_cv =0 for steady flow"
h[2] + q_in_noreg = h[3]
h[3]=ENTHALPY(Air,T=T[3])
P[3]=P[2]"process 2-3 is SSSF constant pressure"

"Turbine analysis"
s[3]=ENTROPY(Air,T=T[3],P=P[3])
s_s[4]=s[3] "For the ideal case the entropies are constant across the turbine"
P[4] = P[3] /Pratio
s_s[4]=ENTROPY(Air,T=T_s[4],P=P[4])"T_s[4] is the isentropic value of T[4] at turbine exit"
Eta_t = w_turb /w_turbisen "turbine adiabatic efficiency, w_turbisen > w_turb"

"SSSF First Law for the isentropic turbine, assuming: adiabatic, ke=pe=0
e_in -e_out = DELTAe_cv = 0 for steady-flow"
h[3] = w_turbisen + h_s[4]
h_s[4]=ENTHALPY(Air,T=T_s[4])
"Actual Turbine analysis:"
h[3] = w_turb + h[4]
h[4]=ENTHALPY(Air,T=T[4])
s[4]=ENTROPY(Air,T=T[4], P=P[4])

"Cycle analysis"
w_net=w_turb-w_comp
Eta_th_noreg=w_net/q_in_noreg*Convert(, %) "[%]" "Cycle thermal efficiency"
Bwr=w_comp/w_turb"Back work ratio"
```

"With the regenerator the heat added in the external heat exchanger is"

```
h[5] + q_in_withreg = h[3]
h[5]=ENTHALPY(Air, T=T[5])
s[5]=ENTROPY(Air,T=T[5], P=P[5])
P[5]=P[2]
```

"The regenerator effectiveness gives h[5] and thus T[5] as:"

$$\text{Eta_reg} = (h[5]-h[2])/(h[4]-h[2])$$

"Energy balance on regenerator gives h[6] and thus T[6] as:"

```
h[2] + h[4]=h[5] + h[6]
h[6]=ENTHALPY(Air, T=T[6])
s[6]=ENTROPY(Air,T=T[6], P=P[6])
P[6]=P[4]
```

"Cycle thermal efficiency with regenerator"

$$\text{Eta_th_withreg} = w_net/q_in_withreg * \text{Convert}(, \%) \text{ "[\%]"}$$

"The following data is used to complete the Array Table for plotting purposes."

```
s_s[1]=s[1]
T_s[1]=T[1]
s_s[3]=s[3]
T_s[3]=T[3]
s_s[5]=ENTROPY(Air,T=T[5],P=P[5])
T_s[5]=T[5]
s_s[6]=s[6]
T_s[6]=T[6]
```

η_c	η_t	$\eta_{th,noreg}$ [%]	$\eta_{th,withreg}$ [%]	$q_{in,noreg}$ [kJ/kg]	$q_{in,withreg}$ [kJ/kg]	W_{net} [kJ/kg]
0.6	0.9	14.76	13.92	510.9	541.6	75.4
0.65	0.9	20.35	20.54	546.8	541.6	111.3
0.7	0.9	24.59	26.22	577.5	541.6	142
0.75	0.9	27.91	31.14	604.2	541.6	168.6
0.8	0.9	30.59	35.44	627.5	541.6	192
0.85	0.9	32.79	39.24	648	541.6	212.5
0.9	0.9	34.64	42.61	666.3	541.6	230.8

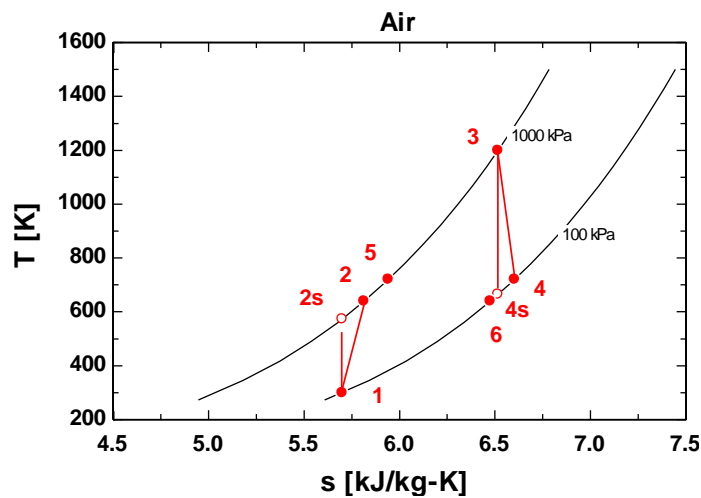

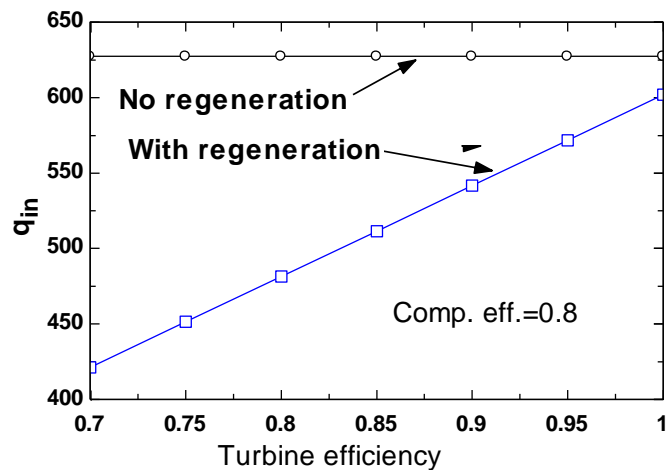
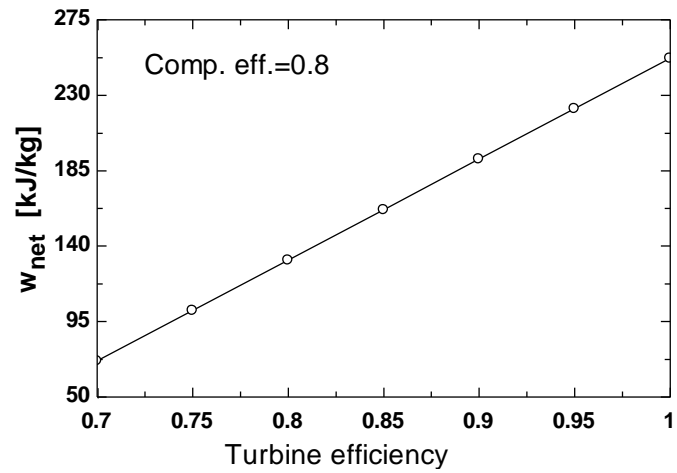
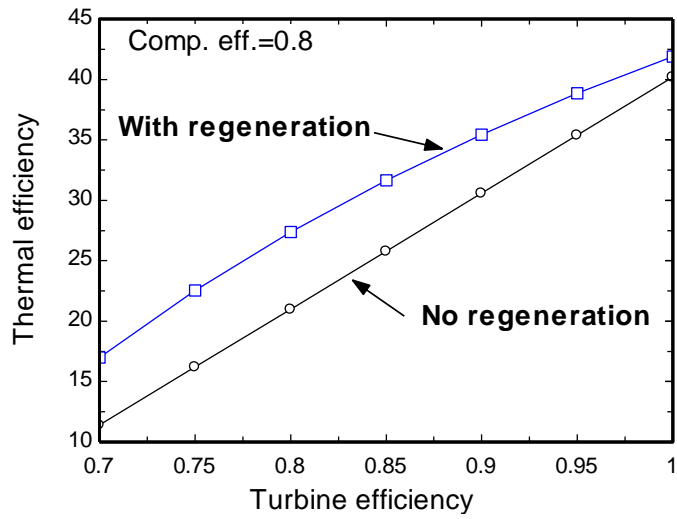

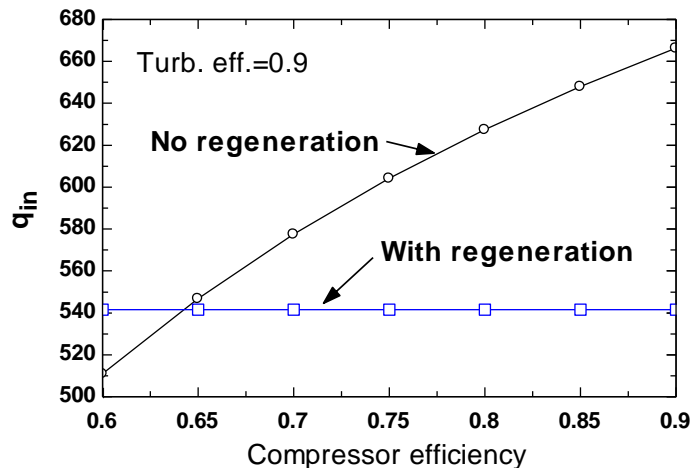
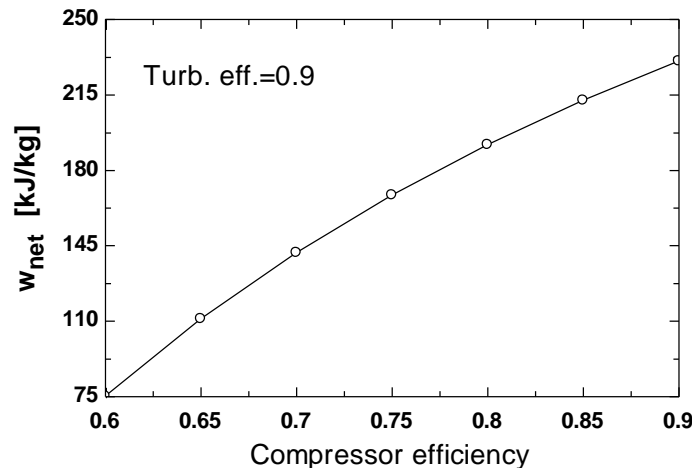
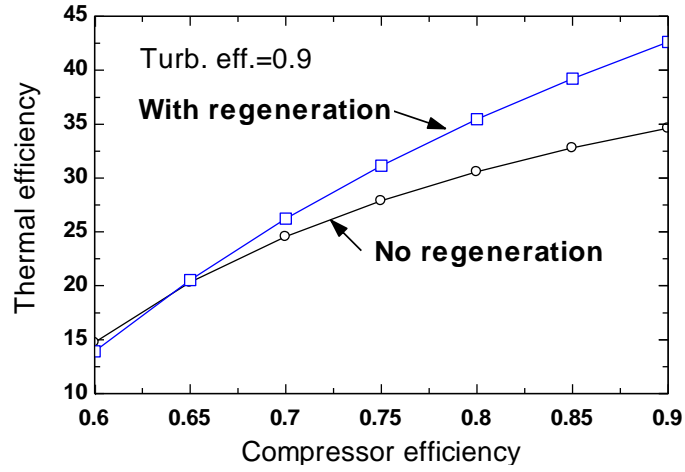



9-181 The effects of pressure ratio, maximum cycle temperature, regenerator effectiveness, and compressor and turbine efficiencies on the net work output per unit mass and the thermal efficiency of a regenerative Brayton cycle with helium as the working fluid is to be investigated.

Analysis Using EES, the problem is solved as follows:

"Input data for helium"

$C_P = 5.1926$ [kJ/kg-K]

$k = 1.667$

"Other Input data from the diagram window"

$\{T[3] = 1200$ [K]

Pratio = 10

$T[1] = 300$ [K]

$P[1] = 100$ [kPa]

Eta_reg = 1.0

Eta_c = 0.8 "Compressor isentropic efficiency"

Eta_t = 0.9 "Turbine isentropic efficiency"

"Isentropic Compressor analysis"

$T_{s[2]} = T[1] \cdot \text{Pratio}^{((k-1)/k)}$

$P[2] = \text{Pratio} \cdot P[1]$

" $T_{s[2]}$ is the isentropic value of $T[2]$ at compressor exit"

$\text{Eta}_c = w_{\text{compisen}} / w_{\text{comp}}$

"compressor adiabatic efficiency, $W_{\text{comp}} > W_{\text{compisen}}$ "

"Conservation of energy for the compressor for the isentropic case:

$e_{\text{in}} - e_{\text{out}} = \Delta e = 0$ for steady-flow"

$w_{\text{compisen}} = C_P \cdot (T_{s[2]} - T[1])$

"Actual compressor analysis:"

$w_{\text{comp}} = C_P \cdot (T[2] - T[1])$

"External heat exchanger analysis"

"SSSF First Law for the heat exchanger, assuming $W=0$, $ke=pe=0$

$e_{\text{in}} - e_{\text{out}} = \Delta e_{\text{cv}} = 0$ for steady flow"

$q_{\text{in,noreg}} = C_P \cdot (T[3] - T[2])$

$P[3] = P[2]$ "process 2-3 is SSSF constant pressure"

"Turbine analysis"

$P[4] = P[3] / \text{Pratio}$

$T_{s[4]} = T[3] \cdot (1 / \text{Pratio})^{((k-1)/k)}$

" $T_{s[4]}$ is the isentropic value of $T[4]$ at turbine exit"

$\text{Eta}_t = w_{\text{turb}} / w_{\text{turbisen}}$ "turbine adiabatic efficiency, $w_{\text{turbisen}} > w_{\text{turb}}$ "

"SSSF First Law for the isentropic turbine, assuming: adiabatic, $ke=pe=0$

$e_{\text{in}} - e_{\text{out}} = \Delta e_{\text{cv}} = 0$ for steady-flow"

$w_{\text{turbisen}} = C_P \cdot (T[3] - T_{s[4]})$

"Actual Turbine analysis:"

$w_{\text{turb}} = C_P \cdot (T[3] - T[4])$

"Cycle analysis"

$w_{\text{net}} = w_{\text{turb}} - w_{\text{comp}}$

$\text{Eta}_{\text{th,noreg}} = w_{\text{net}} / q_{\text{in,noreg}} \cdot \text{Convert}(, \%)$ "[%]" "Cycle thermal efficiency"

$\text{Bwr} = w_{\text{comp}} / w_{\text{turb}}$ "Back work ratio"

"With the regenerator the heat added in the external heat exchanger is"

$$q_{in_withreg} = C_P(T[3] - T[5])$$

$$P[5]=P[2]$$

"The regenerator effectiveness gives $h[5]$ and thus $T[5]$ as:"

$$Eta_{reg} = (T[5]-T[2])/(T[4]-T[2])$$

"Energy balance on regenerator gives $h[6]$ and thus $T[6]$ as:"

$$T[2] + T[4]=T[5] + T[6]$$

$$P[6]=P[4]$$

"Cycle thermal efficiency with regenerator"

$$Eta_{th_withreg}=w_{net}/q_{in_withreg}*Convert(, \%)"["\%"]$$

η_c	η_t	$\eta_{th,noreg}$ [%]	$\eta_{th,withreg}$ [%]	$Q_{in,noreg}$ [kJ/kg]	$Q_{in,withreg}$ [kJ/kg]	W_{net} [kJ/kg]
0.6	0.9	14.76	13.92	510.9	541.6	75.4
0.65	0.9	20.35	20.54	546.8	541.6	111.3
0.7	0.9	24.59	26.22	577.5	541.6	142
0.75	0.9	27.91	31.14	604.2	541.6	168.6
0.8	0.9	30.59	35.44	627.5	541.6	192
0.85	0.9	32.79	39.24	648	541.6	212.5
0.9	0.9	34.64	42.61	666.3	541.6	230.8



9-182 The effect of the number of compression and expansion stages on the thermal efficiency of an ideal regenerative Brayton cycle with multistage compression and expansion and air as the working fluid is to be investigated.

Analysis Using EES, the problem is solved as follows:

"Input data for air"

$$C_P = 1.005 \text{ [kJ/kg-K]}$$

$$k = 1.4$$

"Nstages is the number of compression and expansion stages"

$$N_{\text{stages}} = 1$$

$$T_6 = 1200 \text{ [K]}$$

$$Pr_{\text{ratio}} = 12$$

$$T_1 = 300 \text{ [K]}$$

$$P_1 = 100 \text{ [kPa]}$$

$$\eta_{\text{reg}} = 1.0 \text{ "regenerator effectiveness"}$$

$$\eta_{\text{c}} = 1.0 \text{ "Compressor isentropic efficiency"}$$

$$\eta_{\text{t}} = 1.0 \text{ "Turbine isentropic efficiency"}$$

$$R_p = Pr_{\text{ratio}}^{(1/N_{\text{stages}})}$$

"Isentropic Compressor analysis"

$$T_{2s} = T_1 R_p^{(k-1)/k}$$

$$P_2 = R_p P_1$$

"T_{2s} is the isentropic value of T₂ at compressor exit"

$$\eta_{\text{c}} = w_{\text{compisen}}/w_{\text{comp}}$$

"compressor adiabatic efficiency, $W_{\text{comp}} > W_{\text{compisen}}$ "

"Conservation of energy for the compressor for the isentropic case:

$$e_{\text{in}} - e_{\text{out}} = \Delta e = 0 \text{ for steady-flow}$$

$$w_{\text{compisen}} = C_P (T_{2s} - T_1)$$

"Actual compressor analysis:"

$$w_{\text{comp}} = C_P (T_2 - T_1)$$

"Since intercooling is assumed to occur such that $T_3 = T_1$ and the compressors have the same pressure ratio, the work input to each compressor is the same. The total compressor work is:"

$$w_{\text{comp_total}} = N_{\text{stages}} w_{\text{comp}}$$

"External heat exchanger analysis"

"SSSF First Law for the heat exchanger, assuming $W=0$, $ke=pe=0$

$$e_{\text{in}} - e_{\text{out}} = \Delta e_{\text{cv}} = 0 \text{ for steady flow}$$

"The heat added in the external heat exchanger + the reheat between turbines is"

$$q_{\text{in_total}} = C_P (T_6 - T_5) + (N_{\text{stages}} - 1) C_P (T_8 - T_7)$$

"Reheat is assumed to occur until:"

$$T_8 = T_6$$

"Turbine analysis"

$$P_7 = P_6 / R_p$$

"T_{7s} is the isentropic value of T₇ at turbine exit"

$$T_{7s} = T_6 (1/R_p)^{(k-1)/k}$$

"Turbine adiabatic efficiency, $w_{\text{turbisen}} > w_{\text{turb}}$ "

$$\eta_{\text{t}} = w_{\text{turb}} / w_{\text{turbisen}}$$

"SSSF First Law for the isentropic turbine, assuming: adiabatic, $ke=pe=0$

$$e_{\text{in}} - e_{\text{out}} = \Delta e_{\text{cv}} = 0 \text{ for steady-flow}$$

$$w_{\text{turbisen}} = C_P (T_6 - T_{7s})$$

"Actual Turbine analysis:"

$$w_{\text{turb}} = C_P (T_6 - T_7)$$

$$w_{\text{turb_total}} = N_{\text{stages}} w_{\text{turb}}$$

"Cycle analysis"

$$w_{\text{net}} = w_{\text{turb_total}} - w_{\text{comp_total}} \text{ "[kJ/kg]"}$$

$$Bwr = w_{\text{comp}} / w_{\text{turb}} \text{ "Back work ratio"}$$

$$P_4 = P_2$$

$$P_5 = P_4$$

$$P_6 = P_5$$

$$T_4 = T_2$$

"The regenerator effectiveness gives T_5 as:"

$$\text{Eta}_{\text{reg}} = (T_5 - T_4)/(T_9 - T_4)$$

$$T_9 = T_7$$

"Energy balance on regenerator gives T_{10} as:"

$$T_4 + T_9 = T_5 + T_{10}$$

"Cycle thermal efficiency with regenerator"

$$\text{Eta}_{\text{th,regenerative}} = w_{\text{net}}/q_{\text{in,total}} * \text{Convert}(, \%) \text{ "[\%]"}'$$

"The efficiency of the Ericsson cycle is the same as the Carnot cycle operating between the same max and min temperatures, T_6 and T_1 for this problem."

$$\text{Eta}_{\text{th,Ericsson}} = (1 - T_1/T_6) * \text{Convert}(, \%) \text{ "[\%]"}'$$

$\eta_{\text{th,Ericsson}}$ [%]	$\eta_{\text{th,Regenerative}}$ [%]	Nstages
75	49.15	1
75	64.35	2
75	68.32	3
75	70.14	4
75	72.33	7
75	73.79	15
75	74.05	19
75	74.18	22

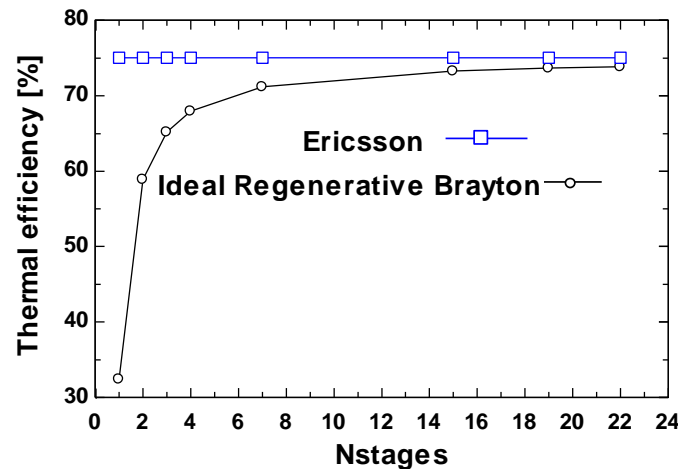



9-183 The effect of the number of compression and expansion stages on the thermal efficiency of an ideal regenerative Brayton cycle with multistage compression and expansion and helium as the working fluid is to be investigated.

Analysis Using EES, the problem is solved as follows:

"Input data for Helium"

$$C_P = 5.1926 \text{ [kJ/kg-K]}$$

$$k = 1.667$$

"Nstages is the number of compression and expansion stages"

$$\{Nstages = 1\}$$

$$T_6 = 1200 \text{ [K]}$$

$$Pratio = 12$$

$$T_1 = 300 \text{ [K]}$$

$$P_1 = 100 \text{ [kPa]}$$

$$Eta_{reg} = 1.0 \text{ "regenerator effectiveness"}$$

$$Eta_c = 1.0 \text{ "Compressor isentropic efficiency"}$$

$$Eta_t = 1.0 \text{ "Turbine isentropic efficiency"}$$

$$R_p = Pratio^{(1/Nstages)}$$

"Isentropic Compressor analysis"

$$T_{2s} = T_1 * R_p^{((k-1)/k)}$$

$$P_2 = R_p * P_1$$

"T_{2s} is the isentropic value of T₂ at compressor exit"

$$Eta_c = w_{compisen} / w_{comp}$$

"compressor adiabatic efficiency, $W_{comp} > W_{compisen}$ "

"Conservation of energy for the compressor for the isentropic case:

$$e_{in} - e_{out} = \Delta A_e = 0 \text{ for steady-flow}$$

$$w_{compisen} = C_P * (T_{2s} - T_1)$$

"Actual compressor analysis:"

$$w_{comp} = C_P * (T_2 - T_1)$$

"Since intercooling is assumed to occur such that $T_3 = T_1$ and the compressors have the same pressure ratio, the work input to each compressor is the same. The total compressor work is:"

$$w_{comp_total} = Nstages * w_{comp}$$

"External heat exchanger analysis"

"SSSF First Law for the heat exchanger, assuming $W=0$, $ke=pe=0$

$$e_{in} - e_{out} = \Delta A_e_{cv} = 0 \text{ for steady flow}$$

"The heat added in the external heat exchanger + the reheat between turbines is"

$$q_{in_total} = C_P * (T_6 - T_5) + (Nstages - 1) * C_P * (T_8 - T_7)$$

"Reheat is assumed to occur until:"

$$T_8 = T_6$$

"Turbine analysis"

$$P_7 = P_6 / R_p$$

"T_{7s} is the isentropic value of T₇ at turbine exit"

$$T_{7s} = T_6 * (1/R_p)^{((k-1)/k)}$$

"Turbine adiabatic efficiency, $w_{turbisen} > w_{turb}$ "

$$Eta_t = w_{turb} / w_{turbisen}$$

"SSSF First Law for the isentropic turbine, assuming: adiabatic, $ke=pe=0$

$$e_{in} - e_{out} = \Delta A_e_{cv} = 0 \text{ for steady-flow}$$

$$w_{turbisen} = C_P * (T_6 - T_{7s})$$

"Actual Turbine analysis:"

$$w_{turb} = C_P * (T_6 - T_7)$$

$$w_{turb_total} = Nstages * w_{turb}$$

"Cycle analysis"

$$w_{net} = w_{turb_total} - w_{comp_total}$$

$$Bwr = w_{comp} / w_{turb} \text{ "Back work ratio"}$$

$$P_4 = P_2$$

$$P_5 = P_4$$

$$P_6 = P_5$$

$$T_4 = T_2$$

"The regenerator effectiveness gives T_5 as:"

$$\text{Eta}_{\text{reg}} = (T_5 - T_4) / (T_9 - T_4)$$

$$T_9 = T_7$$

"Energy balance on regenerator gives T_{10} as:"

$$T_4 + T_9 = T_5 + T_{10}$$

"Cycle thermal efficiency with regenerator"

$$\text{Eta}_{\text{th,regenerative}} = w_{\text{net}} / q_{\text{in,total}} * \text{Convert}(, \%) \text{ "[\%]"}$$

"The efficiency of the Ericsson cycle is the same as the Carnot cycle operating between the same max and min temperatures, T_6 and T_1 for this problem."

$$\text{Eta}_{\text{th, Ericsson}} = (1 - T_1 / T_6) * \text{Convert}(, \%) \text{ "[\%]"}$$

$\eta_{\text{th, Ericsson}}$ [%]	$\eta_{\text{th, Regenerative}}$ [%]	Nstages
75	32.43	1
75	58.9	2
75	65.18	3
75	67.95	4
75	71.18	7
75	73.29	15
75	73.66	19
75	73.84	22

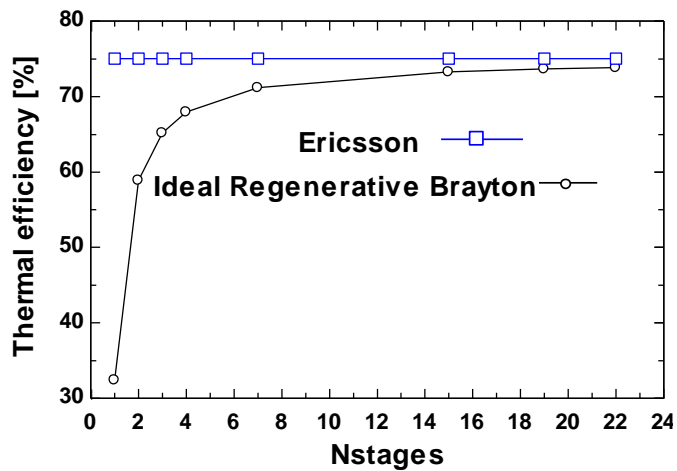

Fundamentals of Engineering (FE) Exam Problems

9-184 An Otto cycle with air as the working fluid has a compression ratio of 10.4. Under cold air standard conditions, the thermal efficiency of this cycle is

- (a) 10% (b) 39% (c) 61% (d) 79% (e) 82%

Answer (c) 61%

Solution Solved by EES Software. Solutions can be verified by copying-and-pasting the following lines on a blank EES screen. (Similar problems and their solutions can be obtained easily by modifying numerical values).

$$r=10.4$$

$$k=1.4$$

$$\text{Eta_Otto}=1-1/r^{(k-1)}$$

"Some Wrong Solutions with Common Mistakes:"

$$W1_Eta = 1/r \text{ "Taking efficiency to be } 1/r\text{"}$$

$$W2_Eta = 1/r^{(k-1)} \text{ "Using incorrect relation"}$$

$$W3_Eta = 1-1/r^{(k1-1)}; k1=1.667 \text{ "Using wrong k value"}$$

9-185 For specified limits for the maximum and minimum temperatures, the ideal cycle with the lowest thermal efficiency is

- (a) Carnot (b) Stirling (c) Ericsson (d) Otto (e) All are the same

Answer (d) Otto

9-186 A Carnot cycle operates between the temperatures limits of 300 K and 2000 K, and produces 600 kW of net power. The rate of entropy change of the working fluid during the heat addition process is

- (a) 0 (b) 0.300 kW/K (c) 0.353 kW/K (d) 0.261 kW/K (e) 2.0 kW/K

Answer (c) 0.353 kW/K

Solution Solved by EES Software. Solutions can be verified by copying-and-pasting the following lines on a blank EES screen. (Similar problems and their solutions can be obtained easily by modifying numerical values).

$$TL=300 \text{ "K"}$$

$$TH=2000 \text{ "K"}$$

$$W_{net}=600 \text{ "kJ/s"}$$

$$W_{net} = (TH-TL)*DS$$

"Some Wrong Solutions with Common Mistakes:"

$$W1_DS = W_{net}/TH \text{ "Using TH instead of TH-TL"}$$

$$W2_DS = W_{net}/TL \text{ "Using TL instead of TH-TL"}$$

$$W3_DS = W_{net}/(TH+TL) \text{ "Using TH+TL instead of TH-TL"}$$

9-187 Air in an ideal Diesel cycle is compressed from 2 L to 0.13 L, and then it expands during the constant pressure heat addition process to 0.30 L. Under cold air standard conditions, the thermal efficiency of this cycle is

- (a) 41% (b) 59% (c) 66% (d) 70% (e) 78%

Answer (b) 59%

Solution Solved by EES Software. Solutions can be verified by copying-and-pasting the following lines on a blank EES screen. (Similar problems and their solutions can be obtained easily by modifying numerical values).

```
V1=2 "L"
V2= 0.13 "L"
V3= 0.30 "L"
r=V1/V2
rc=V3/V2
k=1.4
Eta_Diesel=1-(1/r^(k-1))*(rc^k-1)/k/(rc-1)
```

"Some Wrong Solutions with Common Mistakes:"

```
W1_Eta = 1-(1/r1^(k-1))*(rc^k-1)/k/(rc-1); r1=V1/V3 "Wrong r value"
W2_Eta = 1-Eta_Diesel "Using incorrect relation"
W3_Eta = 1-(1/r^(k1-1))*(rc^k1-1)/k1/(rc-1); k1=1.667 "Using wrong k value"
W4_Eta = 1-1/r^(k-1) "Using Otto cycle efficiency"
```

9-188 Helium gas in an ideal Otto cycle is compressed from 20°C and 2.5 L to 0.25 L, and its temperature increases by an additional 700°C during the heat addition process. The temperature of helium before the expansion process is

- (a) 1790°C (b) 2060°C (c) 1240°C (d) 620°C (e) 820°C

Answer (a) 1790°C

Solution Solved by EES Software. Solutions can be verified by copying-and-pasting the following lines on a blank EES screen. (Similar problems and their solutions can be obtained easily by modifying numerical values).

```
k=1.667
V1=2.5
V2=0.25
r=V1/V2
T1=20+273 "K"
T2=T1*r^(k-1)
T3=T2+700-273 "C"
```

"Some Wrong Solutions with Common Mistakes:"

```
W1_T3 = T22+700-273; T22=T1*r^(k1-1); k1=1.4 "Using wrong k value"
W2_T3 = T3+273 "Using K instead of C"
W3_T3 = T1+700-273 "Disregarding temp rise during compression"
W4_T3 = T222+700-273; T222=(T1-273)*r^(k-1) "Using C for T1 instead of K"
```

9-189 In an ideal Otto cycle, air is compressed from 1.20 kg/m³ and 2.2 L to 0.26 L, and the net work output of the cycle is 440 kJ/kg. The mean effective pressure (MEP) for this cycle is

- (a) 612 kPa (b) 599 kPa (c) 528 kPa (d) 416 kPa (e) 367 kPa

Answer (b) 599 kPa

Solution Solved by EES Software. Solutions can be verified by copying-and-pasting the following lines on a blank EES screen. (Similar problems and their solutions can be obtained easily by modifying numerical values).

```
rho1=1.20 "kg/m^3"
k=1.4
V1=2.2
V2=0.26
m=rho1*V1/1000 "kg"
w_net=440 "kJ/kg"
Wtotal=m*w_net
MEP=Wtotal/((V1-V2)/1000)
```

"Some Wrong Solutions with Common Mistakes:"

```
W1_MEP = w_net/((V1-V2)/1000) "Disregarding mass"
W2_MEP = Wtotal/(V1/1000) "Using V1 instead of V1-V2"
W3_MEP = (rho1*V2/1000)*w_net/((V1-V2)/1000); "Finding mass using V2 instead of V1"
W4_MEP = Wtotal/((V1+V2)/1000) "Adding V1 and V2 instead of subtracting"
```

9-190 In an ideal Brayton cycle, air is compressed from 95 kPa and 25°C to 1100 kPa. Under cold air standard conditions, the thermal efficiency of this cycle is

- (a) 45% (b) 50% (c) 62% (d) 73% (e) 86%

Answer (b) 50%

Solution Solved by EES Software. Solutions can be verified by copying-and-pasting the following lines on a blank EES screen. (Similar problems and their solutions can be obtained easily by modifying numerical values).

```
P1=95 "kPa"
P2=1100 "kPa"
T1=25+273 "K"
rp=P2/P1
k=1.4
Eta_Brayton=1-1/rp^((k-1)/k)
```

"Some Wrong Solutions with Common Mistakes:"

```
W1_Eta = 1/rp "Taking efficiency to be 1/rp"
W2_Eta = 1/rp^((k-1)/k) "Using incorrect relation"
W3_Eta = 1-1/rp^((k1-1)/k1); k1=1.667 "Using wrong k value"
```

9-191 Consider an ideal Brayton cycle executed between the pressure limits of 1200 kPa and 100 kPa and temperature limits of 20°C and 1000°C with argon as the working fluid. The net work output of the cycle is

- (a) 68 kJ/kg (b) 93 kJ/kg (c) 158 kJ/kg (d) 186 kJ/kg (e) 310 kJ/kg

Answer (c) 158 kJ/kg

Solution Solved by EES Software. Solutions can be verified by copying-and-pasting the following lines on a blank EES screen. (Similar problems and their solutions can be obtained easily by modifying numerical values).

```
P1=100 "kPa"
P2=1200 "kPa"
T1=20+273 "K"
T3=1000+273 "K"
rp=P2/P1
k=1.667
Cp=0.5203 "kJ/kg.K"
Cv=0.3122 "kJ/kg.K"
T2=T1*rp^((k-1)/k)
q_in=Cp*(T3-T2)
Eta_Brayton=1-1/rp^((k-1)/k)
w_net=Eta_Brayton*q_in
```

"Some Wrong Solutions with Common Mistakes:"

```
W1_wnet = (1-1/rp^((k-1)/k))*qin1; qin1=Cv*(T3-T2) "Using Cv instead of Cp"
W2_wnet = (1-1/rp^((k-1)/k))*qin2; qin2=1.005*(T3-T2) "Using Cp of air instead of argon"
W3_wnet = (1-1/rp^((k1-1)/k1))*Cp*(T3-T22); T22=T1*rp^((k1-1)/k1); k1=1.4 "Using k of air instead of argon"
W4_wnet = (1-1/rp^((k-1)/k))*Cp*(T3-T222); T222=(T1-273)*rp^((k-1)/k) "Using C for T1 instead of K"
```

9-192 An ideal Brayton cycle has a net work output of 150 kJ/kg and a backwork ratio of 0.4. If both the turbine and the compressor had an isentropic efficiency of 85%, the net work output of the cycle would be

- (a) 74 kJ/kg (b) 95 kJ/kg (c) 109 kJ/kg (d) 128 kJ/kg (e) 177 kJ/kg

Answer (b) 95 kJ/kg

Solution Solved by EES Software. Solutions can be verified by copying-and-pasting the following lines on a blank EES screen. (Similar problems and their solutions can be obtained easily by modifying numerical values).

```
wcomp/wturb=0.4
wturb-wcomp=150 "kJ/kg"
Eff=0.85
w_net=Eff*wturb-wcomp/Eff
```

"Some Wrong Solutions with Common Mistakes:"

```
W1_wnet = Eff*wturb-wcomp*Eff "Making a mistake in Wnet relation"
W2_wnet = (wturb-wcomp)/Eff "Using a wrong relation"
W3_wnet = wturb/eff-wcomp*Eff "Using a wrong relation"
```

9-193 In an ideal Brayton cycle, air is compressed from 100 kPa and 25°C to 1 MPa, and then heated to 927°C before entering the turbine. Under cold air standard conditions, the air temperature at the turbine exit is

- (a) 349°C (b) 426°C (c) 622°C (d) 733°C (e) 825°C

Answer (a) 349°C

Solution Solved by EES Software. Solutions can be verified by copying-and-pasting the following lines on a blank EES screen. (Similar problems and their solutions can be obtained easily by modifying numerical values).

```
P1=100 "kPa"
P2=1000 "kPa"
T1=25+273 "K"
T3=900+273 "K"
rp=P2/P1
k=1.4
T4=T3*(1/rp)^((k-1)/k)-273
```

"Some Wrong Solutions with Common Mistakes:"

```
W1_T4 = T3/rp "Using wrong relation"
W2_T4 = (T3-273)/rp "Using wrong relation"
W3_T4 = T4+273 "Using K instead of C"
W4_T4 = T1+800-273 "Disregarding temp rise during compression"
```

9-194 In an ideal Brayton cycle with regeneration, argon gas is compressed from 100 kPa and 25°C to 400 kPa, and then heated to 1200°C before entering the turbine. The highest temperature that argon can be heated in the regenerator is

- (a) 246°C (b) 846°C (c) 689°C (d) 368°C (e) 573°C

Answer (e) 573°C

Solution Solved by EES Software. Solutions can be verified by copying-and-pasting the following lines on a blank EES screen. (Similar problems and their solutions can be obtained easily by modifying numerical values).

```
k=1.667
Cp=0.5203 "kJ/kg.K"
P1=100 "kPa"
P2=400 "kPa"
T1=25+273 "K"
T3=1200+273 "K"
"The highest temperature that argon can be heated in the regenerator is the turbine exit temperature,"
rp=P2/P1
T2=T1*rp^((k-1)/k)
T4=T3/rp^((k-1)/k)-273
```

"Some Wrong Solutions with Common Mistakes:"

```
W1_T4 = T3/rp "Using wrong relation"
W2_T4 = (T3-273)/rp^((k-1)/k) "Using C instead of K for T3"
W3_T4 = T4+273 "Using K instead of C"
W4_T4 = T2-273 "Taking compressor exit temp as the answer"
```

9-195 In an ideal Brayton cycle with regeneration, air is compressed from 80 kPa and 10°C to 400 kPa and 175°C, is heated to 450°C in the regenerator, and then further heated to 1000°C before entering the turbine. Under cold air standard conditions, the effectiveness of the regenerator is

- (a) 33% (b) 44% (c) 62% (d) 77% (e) 89%

Answer (d) 77%

Solution Solved by EES Software. Solutions can be verified by copying-and-pasting the following lines on a blank EES screen. (Similar problems and their solutions can be obtained easily by modifying numerical values).

$k=1.4$

$C_p=1.005$ "kJ/kg.K"

$P_1=80$ "kPa"

$P_2=400$ "kPa"

$T_1=10+273$ "K"

$T_2=175+273$ "K"

$T_3=1000+273$ "K"

$T_5=450+273$ "K"

"The highest temperature that the gas can be heated in the regenerator is the turbine exit temperature,"

$rp=P_2/P_1$

$T_{2check}=T_1*rp^{((k-1)/k)}$ "Checking the given value of T2. It checks."

$T_4=T_3/rp^{((k-1)/k)}$

$Effective=(T_5-T_2)/(T_4-T_2)$

"Some Wrong Solutions with Common Mistakes:"

$W1_eff = (T_5-T_2)/(T_3-T_2)$ "Using wrong relation"

$W2_eff = (T_5-T_2)/(T_{44}-T_2)$; $T_{44}=(T_3-273)/rp^{((k-1)/k)}$ "Using C instead of K for T3"

$W3_eff = (T_5-T_2)/(T_{444}-T_2)$; $T_{444}=T_3/rp$ "Using wrong relation for T4"

9-196 Consider a gas turbine that has a pressure ratio of 6 and operates on the Brayton cycle with regeneration between the temperature limits of 20°C and 900°C. If the specific heat ratio of the working fluid is 1.3, the highest thermal efficiency this gas turbine can have is

- (a) 38% (b) 46% (c) 62% (d) 58% (e) 97%

Answer (c) 62%

Solution Solved by EES Software. Solutions can be verified by copying-and-pasting the following lines on a blank EES screen. (Similar problems and their solutions can be obtained easily by modifying numerical values).

$k=1.3$

$rp=6$

$T_1=20+273$ "K"

$T_3=900+273$ "K"

$Eta_regen=1-(T_1/T_3)*rp^{((k-1)/k)}$

"Some Wrong Solutions with Common Mistakes:"

$W1_Eta = 1-((T_1-273)/(T_3-273))*rp^{((k-1)/k)}$ "Using C for temperatures instead of K"

$W2_Eta = (T_1/T_3)*rp^{((k-1)/k)}$ "Using incorrect relation"

$W3_Eta = 1-(T_1/T_3)*rp^{((k1-1)/k1)}$; $k1=1.4$ "Using wrong k value (the one for air)"

9-197 An ideal gas turbine cycle with many stages of compression and expansion and a regenerator of 100 percent effectiveness has an overall pressure ratio of 10. Air enters every stage of compressor at 290 K, and every stage of turbine at 1200 K. The thermal efficiency of this gas-turbine cycle is

- (a) 36% (b) 40% (c) 52% (d) 64% (e) 76%

Answer (e) 76%

Solution Solved by EES Software. Solutions can be verified by copying-and-pasting the following lines on a blank EES screen. (Similar problems and their solutions can be obtained easily by modifying numerical values).

```
k=1.4
rp=10
T1=290 "K"
T3=1200 "K"
Eff=1-T1/T3
```

"Some Wrong Solutions with Common Mistakes:"

```
W1_Eta = 100
W2_Eta = 1-1/rp^((k-1)/k) "Using incorrect relation"
W3_Eta = 1-(T1/T3)*rp^((k-1)/k) "Using wrong relation"
W4_Eta = T1/T3 "Using wrong relation"
```

9-198 Air enters a turbojet engine at 320 m/s at a rate of 30 kg/s, and exits at 650 m/s relative to the aircraft. The thrust developed by the engine is

- (a) 5 kN (b) 10 kN (c) 15 kN (d) 20 kN (e) 26 kN

Answer (b) 10 kN

Solution Solved by EES Software. Solutions can be verified by copying-and-pasting the following lines on a blank EES screen. (Similar problems and their solutions can be obtained easily by modifying numerical values).

```
Vel1=320 "m/s"
Vel2=650 "m/s"
Thrust=m*(Vel2-Vel1)/1000 "kN"
m= 30 "kg/s"
```

"Some Wrong Solutions with Common Mistakes:"

```
W1_thrust = (Vel2-Vel1)/1000 "Disregarding mass flow rate"
W2_thrust = m*Vel2/1000 "Using incorrect relation"
```

9-199 ... 9-205 Design and Essay Problems



Solutions Manual for
Thermodynamics: An Engineering Approach
8th Edition
Yunus A. Çengel, Michael A. Boles
McGraw-Hill, 2015

Chapter 10

VAPOR AND COMBINED POWER CYCLES

PROPRIETARY AND CONFIDENTIAL

This Manual is the proprietary property of McGraw-Hill Education and protected by copyright and other state and federal laws. By opening and using this Manual the user agrees to the following restrictions, and if the recipient does not agree to these restrictions, the Manual should be promptly returned unopened to McGraw-Hill Education: **This Manual is being provided only to authorized professors and instructors for use in preparing for the classes using the affiliated textbook. No other use or distribution of this Manual is permitted. This Manual may not be sold and may not be distributed to or used by any student or other third party. No part of this Manual may be reproduced, displayed or distributed in any form or by any means, electronic or otherwise, without the prior written permission of McGraw-Hill Education.**

Carnot Vapor Cycle

10-1C The Carnot cycle is not a realistic model for steam power plants because (1) limiting the heat transfer processes to two-phase systems to maintain isothermal conditions severely limits the maximum temperature that can be used in the cycle, (2) the turbine will have to handle steam with a high moisture content which causes erosion, and (3) it is not practical to design a compressor that will handle two phases.

10-2E A steady-flow Carnot engine with water as the working fluid operates at specified conditions. The thermal efficiency, the quality at the end of the heat rejection process, and the net work output are to be determined.

Assumptions 1 Steady operating conditions exist. 2 Kinetic and potential energy changes are negligible.

Analysis (a) We note that

$$T_H = T_{\text{sat}@400 \text{ psia}} = 444.6^\circ\text{F} = 904.6 \text{ R}$$

$$T_L = T_{\text{sat}@20 \text{ psia}} = 227.9^\circ\text{F} = 687.9 \text{ R}$$

and

$$\eta_{\text{th,C}} = 1 - \frac{T_L}{T_H} = 1 - \frac{687.9 \text{ R}}{904.6 \text{ R}} = 0.2395 = \mathbf{24.0\%}$$

(b) Noting that $s_4 = s_1 = s_f @ 400 \text{ psia} = 0.62168 \text{ Btu/lbm}\cdot\text{R}$,

$$x_4 = \frac{s_4 - s_f}{s_{fg}} = \frac{0.62168 - 0.3358}{1.3961} = \mathbf{0.205}$$

(c) The enthalpies before and after the heat addition process are

$$h_1 = h_f @ 400 \text{ psia} = 424.13 \text{ Btu/lbm}$$

$$h_2 = h_f + x_2 h_{fg} = 424.13 + (0.95)(780.87) = 1166.0 \text{ Btu/lbm}$$

Thus,

$$q_{\text{in}} = h_2 - h_1 = 1166.0 - 424.13 = 741.8 \text{ Btu/lbm}$$

and

$$w_{\text{net}} = \eta_{\text{th}} q_{\text{in}} = (0.2395)(741.8 \text{ Btu/lbm}) = \mathbf{178 \text{ Btu/lbm}}$$

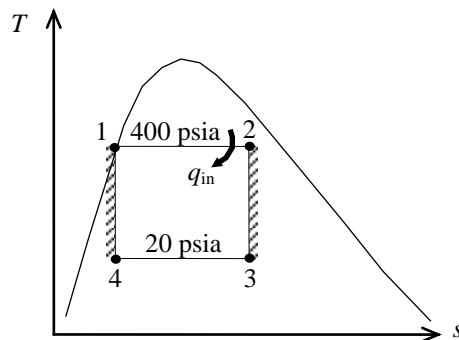

10-3 A steady-flow Carnot engine with water as the working fluid operates at specified conditions. The thermal efficiency, the amount of heat rejected, and the net work output are to be determined.

Assumptions 1 Steady operating conditions exist. 2 Kinetic and potential energy changes are negligible.

Analysis (a) Noting that $T_H = 250^\circ\text{C} = 523\text{ K}$ and $T_L = T_{\text{sat}} @ 20\text{ kPa} = 60.06^\circ\text{C} = 333.1\text{ K}$, the thermal efficiency becomes

$$\eta_{\text{th,C}} = 1 - \frac{T_L}{T_H} = 1 - \frac{333.1\text{ K}}{523\text{ K}} = 0.3632 = \mathbf{36.3\%}$$

(b) The heat supplied during this cycle is simply the enthalpy of vaporization,

$$q_{\text{in}} = h_{fg @ 250^\circ\text{C}} = 1715.3\text{ kJ/kg}$$

Thus,

$$q_{\text{out}} = q_L = \frac{T_L}{T_H} q_{\text{in}} = \left(\frac{333.1\text{ K}}{523\text{ K}} \right) (1715.3\text{ kJ/kg}) = \mathbf{1092.3\text{ kJ/kg}}$$

(c) The net work output of this cycle is

$$w_{\text{net}} = \eta_{\text{th}} q_{\text{in}} = (0.3632)(1715.3\text{ kJ/kg}) = \mathbf{623.0\text{ kJ/kg}}$$

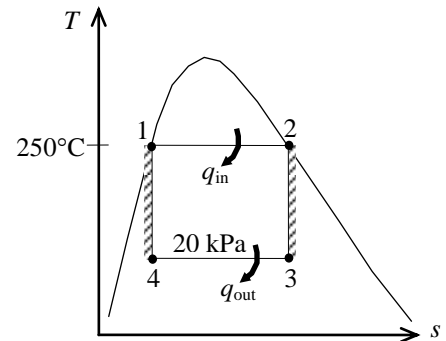

10-4 A steady-flow Carnot engine with water as the working fluid operates at specified conditions. The thermal efficiency, the amount of heat rejected, and the net work output are to be determined.

Assumptions 1 Steady operating conditions exist. 2 Kinetic and potential energy changes are negligible.

Analysis (a) Noting that $T_H = 250^\circ\text{C} = 523\text{ K}$ and $T_L = T_{\text{sat}} @ 10\text{ kPa} = 45.81^\circ\text{C} = 318.8\text{ K}$, the thermal efficiency becomes

$$\eta_{\text{th,C}} = 1 - \frac{T_L}{T_H} = 1 - \frac{318.8\text{ K}}{523\text{ K}} = \mathbf{39.04\%}$$

(b) The heat supplied during this cycle is simply the enthalpy of vaporization,

$$q_{\text{in}} = h_{fg @ 250^\circ\text{C}} = 1715.3\text{ kJ/kg}$$

Thus,

$$q_{\text{out}} = q_L = \frac{T_L}{T_H} q_{\text{in}} = \left(\frac{318.8\text{ K}}{523\text{ K}} \right) (1715.3\text{ kJ/kg}) = \mathbf{1045.6\text{ kJ/kg}}$$

(c) The net work output of this cycle is

$$w_{\text{net}} = \eta_{\text{th}} q_{\text{in}} = (0.3904)(1715.3\text{ kJ/kg}) = \mathbf{669.7\text{ kJ/kg}}$$

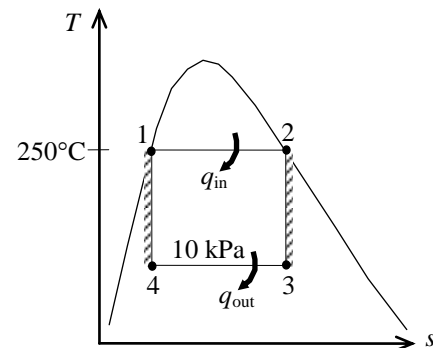

10-5 A steady-flow Carnot engine with water as the working fluid operates at specified conditions. The thermal efficiency, the pressure at the turbine inlet, and the net work output are to be determined.

Assumptions 1 Steady operating conditions exist. 2 Kinetic and potential energy changes are negligible.

Analysis (a) The thermal efficiency is determined from

$$\eta_{\text{th,C}} = 1 - \frac{T_L}{T_H} = 1 - \frac{60 + 273 \text{ K}}{350 + 273 \text{ K}} = \mathbf{46.5\%}$$

(b) Note that

$$\begin{aligned} s_2 = s_3 &= s_f + x_3 s_{fg} \\ &= 0.8313 + 0.891 \times 7.0769 = 7.1368 \text{ kJ/kg} \cdot \text{K} \end{aligned}$$

Thus,

$$\left. \begin{aligned} T_2 &= 350^\circ\text{C} \\ s_2 &= 7.1368 \text{ kJ/kg} \cdot \text{K} \end{aligned} \right\} P_2 \cong \mathbf{1.40 \text{ MPa}} \text{ (Table A-6)}$$

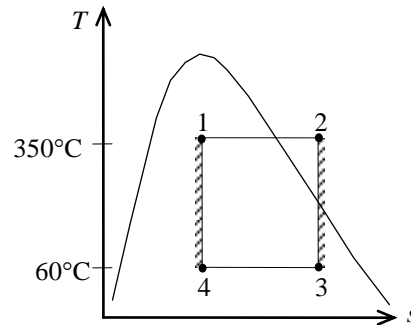

(c) The net work can be determined by calculating the enclosed area on the T - s diagram,

$$s_4 = s_f + x_4 s_{fg} = 0.8313 + (0.1)(7.0769) = 1.5390 \text{ kJ/kg} \cdot \text{K}$$

Thus,

$$w_{\text{net}} = \text{Area} = (T_H - T_L)(s_3 - s_4) = (350 - 60)(7.1368 - 1.5390) = \mathbf{1623 \text{ kJ/kg}}$$

The Simple Rankine Cycle

10-6C Heat rejected decreases; everything else increases.

10-7C Heat rejected decreases; everything else increases.

10-8C The pump work remains the same, the moisture content decreases, everything else increases.

10-9C The actual vapor power cycles differ from the idealized ones in that the actual cycles involve friction and pressure drops in various components and the piping, and heat loss to the surrounding medium from these components and piping.

10-10C We would reject this proposal because $w_{\text{turb}} = h_1 - h_2 - q_{\text{out}}$, and any heat loss from the steam will adversely affect the turbine work output.

10-11C Yes, because the saturation temperature of steam at 10 kPa is 45.81°C, which is much higher than the temperature of the cooling water.

10-12 A steam power plant operates on a simple ideal Rankine cycle between the specified pressure limits. The thermal efficiency of the cycle and the net power output of the plant are to be determined.

Assumptions 1 Steady operating conditions exist. 2 Kinetic and potential energy changes are negligible.

Analysis (a) From the steam tables (Tables A-4, A-5, and A-6),

$$h_1 = h_f @ 50 \text{ kPa} = 340.54 \text{ kJ/kg}$$

$$\nu_1 = \nu_f @ 50 \text{ kPa} = 0.001030 \text{ m}^3/\text{kg}$$

$$\begin{aligned} w_{p,\text{in}} &= \nu_1 (P_2 - P_1) \\ &= (0.001030 \text{ m}^3/\text{kg})(3000 - 50) \text{ kPa} \left(\frac{1 \text{ kJ}}{1 \text{ kPa} \cdot \text{m}^3} \right) \\ &= 3.04 \text{ kJ/kg} \end{aligned}$$

$$h_2 = h_1 + w_{p,\text{in}} = 340.54 + 3.04 = 343.58 \text{ kJ/kg}$$

$$\left. \begin{array}{l} P_3 = 3 \text{ MPa} \\ T_3 = 300^\circ\text{C} \end{array} \right\} \begin{array}{l} h_3 = 2994.3 \text{ kJ/kg} \\ s_3 = 6.5412 \text{ kJ/kg} \cdot \text{K} \end{array}$$

$$\left. \begin{array}{l} P_4 = 50 \text{ kPa} \\ s_4 = s_3 \end{array} \right\} x_4 = \frac{s_4 - s_f}{s_{fg}} = \frac{6.5412 - 1.0912}{6.5019} = 0.8382$$

$$\begin{aligned} h_4 &= h_f + x_4 h_{fg} = 340.54 + (0.8382)(2304.7) \\ &= 2272.3 \text{ kJ/kg} \end{aligned}$$

Thus,

$$q_{\text{in}} = h_3 - h_2 = 2994.3 - 343.58 = 2650.7 \text{ kJ/kg}$$

$$q_{\text{out}} = h_4 - h_1 = 2272.3 - 340.54 = 1931.8 \text{ kJ/kg}$$

$$w_{\text{net}} = q_{\text{in}} - q_{\text{out}} = 2650.7 - 1931.8 = 718.9 \text{ kJ/kg}$$

and

$$\eta_{\text{th}} = 1 - \frac{q_{\text{out}}}{q_{\text{in}}} = 1 - \frac{1931.8}{2650.7} = \mathbf{27.1\%}$$

$$(b) \quad \dot{W}_{\text{net}} = \dot{m} w_{\text{net}} = (35 \text{ kg/s})(718.9 \text{ kJ/kg}) = \mathbf{25.2 \text{ MW}}$$

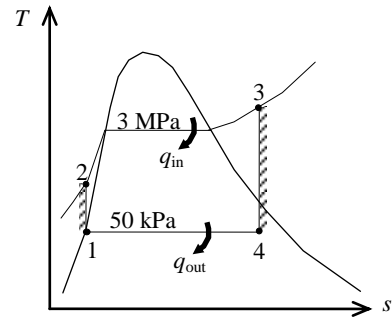

10-13 A simple ideal Rankine cycle with R-134a as the working fluid is considered. The turbine inlet temperature, the cycle thermal efficiency, and the back-work ratio of the cycle are to be determined.

Assumptions 1 Steady operating conditions exist. 2 Kinetic and potential energy changes are negligible.

Analysis From the refrigerant tables (Tables A-11, A-12, and A-13),

$$P_1 = P_{\text{sat}} @ 24^\circ\text{C} = 646.2 \text{ kPa}$$

$$h_1 = h_f @ 24^\circ\text{C} = 84.98 \text{ kJ/kg}$$

$$v_1 = v_f @ 24^\circ\text{C} = 0.0008260 \text{ m}^3/\text{kg}$$

$$\begin{aligned} w_{\text{p,in}} &= v_1(P_2 - P_1) \\ &= (0.0008260 \text{ m}^3/\text{kg})(2000 - 646.2) \text{ kPa} \left(\frac{1 \text{ kJ}}{1 \text{ kPa} \cdot \text{m}^3} \right) \\ &= 1.118 \text{ kJ/kg} \end{aligned}$$

$$h_2 = h_1 + w_{\text{p,in}} = 84.98 + 1.118 = 86.09 \text{ kJ/kg}$$

$$\left. \begin{array}{l} T_4 = 24^\circ\text{C} \\ x_4 = 0.93 \end{array} \right\} \begin{array}{l} h_4 = h_f + x_4 h_{fg} = 84.98 + (0.93)(178.74) = 251.21 \text{ kJ/kg} \\ s_4 = s_f + x_4 s_{fg} = 0.31959 + (0.93)(0.60148) = 0.87897 \text{ kJ/kg} \cdot \text{K} \end{array}$$

$$\left. \begin{array}{l} P_3 = 2000 \text{ kPa} \\ s_3 = s_4 = 0.87897 \text{ kJ/kg} \cdot \text{K} \end{array} \right\} \begin{array}{l} h_3 = 272.29 \text{ kJ/kg} \\ T_3 = \mathbf{67.5^\circ\text{C}} \end{array}$$

Thus,

$$q_{\text{in}} = h_3 - h_2 = 272.29 - 86.09 = 186.2 \text{ kJ/kg}$$

$$q_{\text{out}} = h_4 - h_1 = 251.21 - 84.98 = 166.2 \text{ kJ/kg}$$

The thermal efficiency of the cycle is

$$\eta_{\text{th}} = 1 - \frac{q_{\text{out}}}{q_{\text{in}}} = 1 - \frac{166.2}{186.2} = 0.1072 = \mathbf{10.7\%}$$

The back-work ratio is determined from

$$r_{\text{bw}} = \frac{w_{\text{P,in}}}{W_{\text{T,out}}} = \frac{w_{\text{P,in}}}{h_3 - h_4} = \frac{1.118 \text{ kJ/kg}}{(272.29 - 251.21) \text{ kJ/kg}} = \mathbf{0.0530}$$

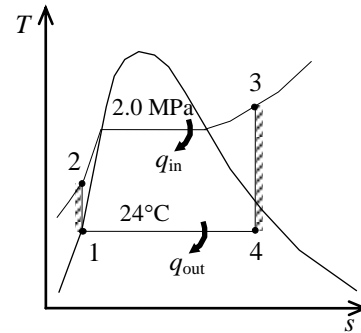

10-14 A simple ideal Rankine cycle with water as the working fluid is considered. The work output from the turbine, the heat addition in the boiler, and the thermal efficiency of the cycle are to be determined.

Assumptions 1 Steady operating conditions exist. 2 Kinetic and potential energy changes are negligible.

Analysis From the steam tables (Tables A-4, A-5, and A-6),

$$P_1 = P_{\text{sat @ } 40^\circ\text{C}} = 7.385 \text{ kPa}$$

$$P_2 = P_{\text{sat @ } 300^\circ\text{C}} = 8588 \text{ kPa}$$

$$h_1 = h_f @ 40^\circ\text{C} = 167.53 \text{ kJ/kg}$$

$$\nu_1 = \nu_f @ 40^\circ\text{C} = 0.001008 \text{ m}^3/\text{kg}$$

$$\begin{aligned} w_{\text{p,in}} &= \nu_1 (P_2 - P_1) \\ &= (0.001008 \text{ m}^3/\text{kg})(8588 - 7.385) \text{ kPa} \left(\frac{1 \text{ kJ}}{1 \text{ kPa} \cdot \text{m}^3} \right) \\ &= 8.65 \text{ kJ/kg} \end{aligned}$$

$$h_2 = h_1 + w_{\text{p,in}} = 167.53 + 8.65 = 176.18 \text{ kJ/kg}$$

$$\left. \begin{array}{l} T_3 = 300^\circ\text{C} \\ x_3 = 1 \end{array} \right\} \begin{array}{l} h_3 = 2749.6 \text{ kJ/kg} \\ s_3 = 5.7059 \text{ kJ/kg} \cdot \text{K} \end{array}$$

$$\left. \begin{array}{l} T_4 = 40^\circ\text{C} \\ s_4 = s_3 \end{array} \right\} \begin{array}{l} x_4 = \frac{s_4 - s_f}{s_{fg}} = \frac{5.7059 - 0.5724}{7.6832} = 0.6681 \\ h_4 = h_f + x_4 h_{fg} = 167.53 + (0.6681)(2406.0) = 1775.1 \text{ kJ/kg} \end{array}$$

Thus,

$$w_{\text{T,out}} = h_3 - h_4 = 2749.6 - 1775.1 = \mathbf{974.5 \text{ kJ/kg}}$$

$$q_{\text{in}} = h_3 - h_2 = 2749.6 - 176.18 = \mathbf{2573.4 \text{ kJ/kg}}$$

$$q_{\text{out}} = h_4 - h_1 = 1775.1 - 167.53 = 1607.6 \text{ kJ/kg}$$

The thermal efficiency of the cycle is

$$\eta_{\text{th}} = 1 - \frac{q_{\text{out}}}{q_{\text{in}}} = 1 - \frac{1607.6}{2573.4} = \mathbf{0.375}$$

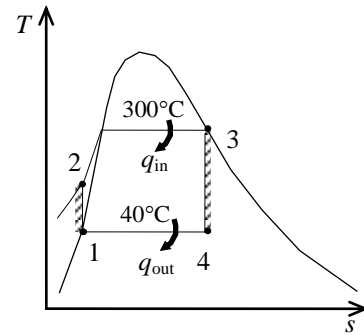

10-15E A simple ideal Rankine cycle with water as the working fluid operates between the specified pressure limits. The turbine inlet temperature and the thermal efficiency of the cycle are to be determined.

Assumptions 1 Steady operating conditions exist. 2 Kinetic and potential energy changes are negligible.

Analysis From the steam tables (Tables A-4E, A-5E, and A-6E),

$$h_1 = h_f @ 5 \text{ psia} = 130.18 \text{ Btu/lbm}$$

$$v_1 = v_f @ 5 \text{ psia} = 0.01641 \text{ ft}^3/\text{lbm}$$

$$\begin{aligned} w_{p,\text{in}} &= v_1 (P_2 - P_1) \\ &= (0.01641 \text{ ft}^3/\text{lbm})(2500 - 5) \text{ psia} \left(\frac{1 \text{ Btu}}{5.404 \text{ psia} \cdot \text{ft}^3} \right) \\ &= 7.58 \text{ Btu/lbm} \end{aligned}$$

$$h_2 = h_1 + w_{p,\text{in}} = 130.18 + 7.58 = 137.76 \text{ Btu/lbm}$$

$$\left. \begin{array}{l} P_4 = 5 \text{ psia} \\ x_4 = 0.80 \end{array} \right\} \begin{array}{l} h_4 = h_f + x_4 h_{fg} = 130.18 + (0.80)(1000.5) = 930.58 \text{ Btu/lbm} \\ s_4 = s_f + x_4 s_{fg} = 0.23488 + (0.80)(1.60894) = 1.52203 \text{ Btu/lbm} \cdot \text{R} \end{array}$$

$$\left. \begin{array}{l} P_3 = 2500 \text{ psia} \\ s_3 = s_4 = 1.52203 \text{ Btu/lbm} \cdot \text{R} \end{array} \right\} \begin{array}{l} h_3 = 1450.8 \text{ Btu/lbm} \\ T_3 = \mathbf{989.2^\circ\text{F}} \end{array}$$

Thus,

$$q_{\text{in}} = h_3 - h_2 = 1450.8 - 137.76 = 1313.0 \text{ Btu/lbm}$$

$$q_{\text{out}} = h_4 - h_1 = 930.58 - 130.18 = 800.4 \text{ Btu/lbm}$$

The thermal efficiency of the cycle is

$$\eta_{\text{th}} = 1 - \frac{q_{\text{out}}}{q_{\text{in}}} = 1 - \frac{800.4}{1313.0} = \mathbf{0.390}$$

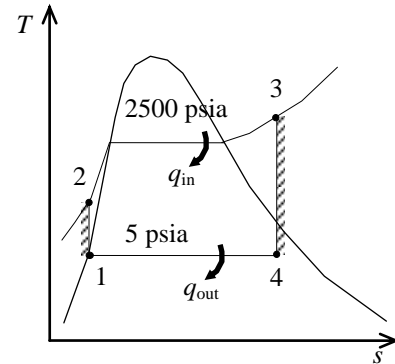

10-16 A steam power plant that operates on a simple ideal Rankine cycle is considered. The quality of the steam at the turbine exit, the thermal efficiency of the cycle, and the mass flow rate of the steam are to be determined.

Assumptions 1 Steady operating conditions exist. 2 Kinetic and potential energy changes are negligible.

Analysis (a) From the steam tables (Tables A-4, A-5, and A-6),

$$h_1 = h_f @ 10 \text{ kPa} = 191.81 \text{ kJ/kg}$$

$$\nu_1 = \nu_f @ 10 \text{ kPa} = 0.00101 \text{ m}^3/\text{kg}$$

$$\begin{aligned} w_{p,\text{in}} &= \nu_1(P_2 - P_1) \\ &= (0.00101 \text{ m}^3/\text{kg})(10,000 - 10 \text{ kPa}) \left(\frac{1 \text{ kJ}}{1 \text{ kPa} \cdot \text{m}^3} \right) \\ &= 10.09 \text{ kJ/kg} \end{aligned}$$

$$h_2 = h_1 + w_{p,\text{in}} = 191.81 + 10.09 = 201.90 \text{ kJ/kg}$$

$$\left. \begin{array}{l} P_3 = 10 \text{ MPa} \\ T_3 = 500 \text{ }^\circ\text{C} \end{array} \right\} \begin{array}{l} h_3 = 3375.1 \text{ kJ/kg} \\ s_3 = 6.5995 \text{ kJ/kg} \cdot \text{K} \end{array}$$

$$\left. \begin{array}{l} P_4 = 10 \text{ kPa} \\ s_4 = s_3 \end{array} \right\} x_4 = \frac{s_4 - s_f}{s_{fg}} = \frac{6.5995 - 0.6492}{7.4996} = \mathbf{0.7934}$$

$$h_4 = h_f + x_4 h_{fg} = 191.81 + (0.7934)(2392.1) = 2089.7 \text{ kJ/kg}$$

$$(b) \quad q_{\text{in}} = h_3 - h_2 = 3375.1 - 201.90 = 3173.2 \text{ kJ/kg}$$

$$q_{\text{out}} = h_4 - h_1 = 2089.7 - 191.81 = 1897.9 \text{ kJ/kg}$$

$$w_{\text{net}} = q_{\text{in}} - q_{\text{out}} = 3173.2 - 1897.9 = 1275.4 \text{ kJ/kg}$$

and

$$\eta_{\text{th}} = \frac{w_{\text{net}}}{q_{\text{in}}} = \frac{1275.4 \text{ kJ/kg}}{3173.2 \text{ kJ/kg}} = \mathbf{40.2\%}$$

$$(c) \quad \dot{m} = \frac{\dot{W}_{\text{net}}}{w_{\text{net}}} = \frac{210,000 \text{ kJ/s}}{1275.4 \text{ kJ/kg}} = \mathbf{164.7 \text{ kg/s}}$$

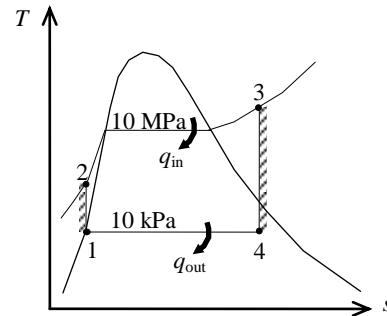

10-17 A steam power plant that operates on a simple nonideal Rankine cycle is considered. The quality of the steam at the turbine exit, the thermal efficiency of the cycle, and the mass flow rate of the steam are to be determined.

Assumptions 1 Steady operating conditions exist. **2** Kinetic and potential energy changes are negligible.

Analysis (a) From the steam tables (Tables A-4, A-5, and A-6),

$$h_1 = h_{f@10\text{ kPa}} = 191.81 \text{ kJ/kg}$$

$$v_1 = v_{f@10\text{ kPa}} = 0.00101 \text{ m}^3/\text{kg}$$

$$\begin{aligned} w_{p,\text{in}} &= v_1(P_2 - P_1)/\eta_p \\ &= (0.00101 \text{ m}^3/\text{kg})(10,000 - 10 \text{ kPa}) \left(\frac{1 \text{ kJ}}{1 \text{ kPa} \cdot \text{m}^3} \right) / (0.85) \\ &= 11.87 \text{ kJ/kg} \end{aligned}$$

$$h_2 = h_1 + w_{p,\text{in}} = 191.81 + 11.87 = 203.68 \text{ kJ/kg}$$

$$\left. \begin{aligned} P_3 &= 10 \text{ MPa} \\ T_3 &= 500^\circ\text{C} \end{aligned} \right\} \begin{aligned} h_3 &= 3375.1 \text{ kJ/kg} \\ s_3 &= 6.5995 \text{ kJ/kg} \cdot \text{K} \end{aligned}$$

$$\left. \begin{aligned} P_{4s} &= 10 \text{ kPa} \\ s_{4s} &= s_3 \end{aligned} \right\} x_{4s} = \frac{s_{4s} - s_f}{s_{fg}} = \frac{6.5995 - 0.6492}{7.4996} = \mathbf{0.7934}$$

$$h_{4s} = h_f + x_{4s}h_{fg} = 191.81 + (0.7934)(2392.1) = 2089.7 \text{ kJ/kg}$$

$$\eta_T = \frac{h_3 - h_4}{h_3 - h_{4s}} \longrightarrow h_4 = h_3 - \eta_T(h_3 - h_{4s}) = 3375.1 - (0.85)(3375.1 - 2089.7) = 2282.5 \text{ kJ/kg}$$

$$\left. \begin{aligned} P_4 &= 10 \text{ kPa} \\ h_4 &= 2282.5 \text{ kJ/kg} \end{aligned} \right\} x_4 = \frac{h_4 - h_f}{h_{fg}} = \frac{2282.5 - 191.81}{2392.1} = \mathbf{0.874}$$

$$\begin{aligned} (b) \quad q_{\text{in}} &= h_3 - h_2 = 3375.1 - 203.68 = 3171.4 \text{ kJ/kg} \\ q_{\text{out}} &= h_4 - h_1 = 2282.5 - 191.81 = 2090.7 \text{ kJ/kg} \\ w_{\text{net}} &= q_{\text{in}} - q_{\text{out}} = 3171.4 - 2090.7 = 1080.7 \text{ kJ/kg} \end{aligned}$$

and

$$\eta_{\text{th}} = \frac{w_{\text{net}}}{q_{\text{in}}} = \frac{1080.7 \text{ kJ/kg}}{3171.5 \text{ kJ/kg}} = \mathbf{34.1\%}$$

$$(c) \quad \dot{m} = \frac{\dot{W}_{\text{net}}}{w_{\text{net}}} = \frac{210,000 \text{ kJ/s}}{1080.7 \text{ kJ/kg}} = \mathbf{194.3 \text{ kg/s}}$$

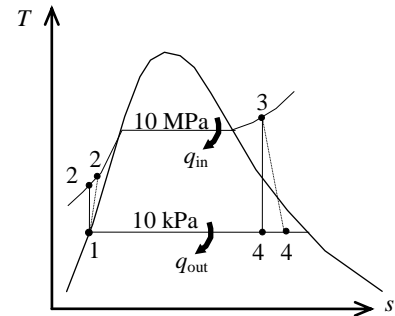

10-18E A simple steam Rankine cycle operates between the specified pressure limits. The mass flow rate, the power produced by the turbine, the rate of heat addition, and the thermal efficiency of the cycle are to be determined.

Assumptions 1 Steady operating conditions exist. **2** Kinetic and potential energy changes are negligible.

Analysis From the steam tables (Tables A-4E, A-5E, and A-6E),

$$h_1 = h_f @ 2 \text{ psia} = 94.02 \text{ Btu/lbm}$$

$$v_1 = v_f @ 2 \text{ psia} = 0.016230 \text{ ft}^3/\text{lbm}$$

$$\begin{aligned} w_{p,\text{in}} &= v_1(P_2 - P_1) \\ &= (0.016230 \text{ ft}^3/\text{lbm})(1500 - 2) \text{ psia} \left(\frac{1 \text{ Btu}}{5.404 \text{ psia} \cdot \text{ft}^3} \right) \\ &= 4.50 \text{ Btu/lbm} \end{aligned}$$

$$h_2 = h_1 + w_{p,\text{in}} = 94.02 + 4.50 = 98.52 \text{ Btu/lbm}$$

$$\left. \begin{array}{l} P_3 = 1500 \text{ psia} \\ T_3 = 800^\circ\text{F} \end{array} \right\} \begin{array}{l} h_3 = 1363.1 \text{ Btu/lbm} \\ s_3 = 1.5064 \text{ Btu/lbm} \cdot \text{R} \end{array}$$

$$\left. \begin{array}{l} P_4 = 2 \text{ psia} \\ s_4 = s_3 \end{array} \right\} \begin{array}{l} x_{4s} = \frac{s_4 - s_f}{s_{fg}} = \frac{1.5064 - 0.1750}{1.7444} = 0.7633 \\ h_{4s} = h_f + x_{4s}h_{fg} = 94.02 + (0.7633)(1021.7) = 873.86 \text{ Btu/lbm} \end{array}$$

$$\eta_T = \frac{h_3 - h_4}{h_3 - h_{4s}} \longrightarrow h_4 = h_3 - \eta_T(h_3 - h_{4s}) = 1363.1 - (0.90)(1363.1 - 873.86) = 922.79 \text{ kJ/kg}$$

Thus,

$$q_{\text{in}} = h_3 - h_2 = 1363.1 - 98.52 = 1264.6 \text{ Btu/lbm}$$

$$q_{\text{out}} = h_4 - h_1 = 922.79 - 94.02 = 828.8 \text{ Btu/lbm}$$

$$w_{\text{net}} = q_{\text{in}} - q_{\text{out}} = 1264.6 - 828.8 = 435.8 \text{ Btu/lbm}$$

The mass flow rate of steam in the cycle is determined from

$$\dot{W}_{\text{net}} = \dot{m}w_{\text{net}} \longrightarrow \dot{m} = \frac{\dot{W}_{\text{net}}}{w_{\text{net}}} = \frac{2500 \text{ kJ/s}}{435.8 \text{ Btu/lbm}} \left(\frac{0.94782 \text{ Btu}}{1 \text{ kJ}} \right) = \mathbf{5.437 \text{ lbm/s}}$$

The power output from the turbine and the rate of heat addition are

$$\dot{W}_{T,\text{out}} = \dot{m}(h_3 - h_4) = (5.437 \text{ lbm/s})(1363.1 - 922.79) \text{ Btu/lbm} \left(\frac{1 \text{ kJ}}{0.94782 \text{ Btu}} \right) = \mathbf{2526 \text{ kW}}$$

$$\dot{Q}_{\text{in}} = \dot{m}q_{\text{in}} = (5.437 \text{ lbm/s})(1264.6 \text{ Btu/lbm}) = \mathbf{6876 \text{ Btu/s}}$$

and the thermal efficiency of the cycle is

$$\eta_{\text{th}} = \frac{\dot{W}_{\text{net}}}{\dot{Q}_{\text{in}}} = \frac{2500 \text{ kJ/s}}{6876 \text{ Btu/s}} \left(\frac{0.94782 \text{ Btu}}{1 \text{ kJ}} \right) = 0.3446 = \mathbf{34.5\%}$$

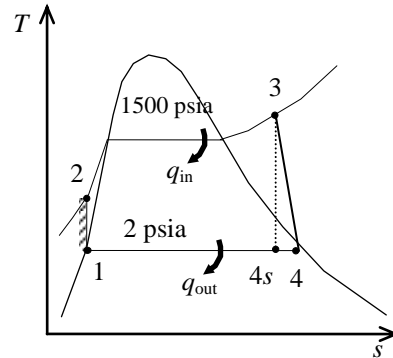

10-19E A simple steam Rankine cycle operates between the specified pressure limits. The mass flow rate, the power produced by the turbine, the rate of heat addition, and the thermal efficiency of the cycle are to be determined.

Assumptions 1 Steady operating conditions exist. **2** Kinetic and potential energy changes are negligible.

Analysis From the steam tables (Tables A-4E, A-5E, and A-6E),

$$h_1 = h_f @ 2 \text{ psia} = 94.02 \text{ Btu/lbm}$$

$$v_1 = v_f @ 2 \text{ psia} = 0.016230 \text{ ft}^3/\text{lbm}$$

$$\begin{aligned} w_{p,\text{in}} &= v_1(P_2 - P_1) \\ &= (0.016230 \text{ ft}^3/\text{lbm})(1500 - 2) \text{ psia} \left(\frac{1 \text{ Btu}}{5.404 \text{ psia} \cdot \text{ft}^3} \right) \\ &= 4.50 \text{ Btu/lbm} \end{aligned}$$

$$h_2 = h_1 + w_{p,\text{in}} = 94.02 + 4.50 = 98.52 \text{ Btu/lbm}$$

$$\left. \begin{array}{l} P_3 = 1500 \text{ psia} \\ T_3 = 800^\circ\text{F} \end{array} \right\} \begin{array}{l} h_3 = 1363.1 \text{ Btu/lbm} \\ s_3 = 1.5064 \text{ Btu/lbm} \cdot \text{R} \end{array}$$

$$\left. \begin{array}{l} P_4 = 2 \text{ psia} \\ s_4 = s_3 \end{array} \right\} \begin{array}{l} x_{4s} = \frac{s_4 - s_f}{s_{fg}} = \frac{1.5064 - 0.1750}{1.7444} = 0.7633 \\ h_{4s} = h_f + x_{4s}h_{fg} = 94.02 + (0.7633)(1021.7) = 873.86 \text{ Btu/lbm} \end{array}$$

$$\eta_T = \frac{h_3 - h_4}{h_3 - h_{4s}} \longrightarrow h_4 = h_3 - \eta_T(h_3 - h_{4s}) = 1363.1 - (0.90)(1363.1 - 873.86) = 922.79 \text{ kJ/kg}$$

The mass flow rate of steam in the cycle is determined from

$$\dot{W}_{\text{net}} = \dot{m}(h_3 - h_4) \longrightarrow \dot{m} = \frac{\dot{W}_{\text{net}}}{h_3 - h_4} = \frac{2500 \text{ kJ/s}}{(1363.1 - 922.79) \text{ Btu/lbm}} \left(\frac{0.94782 \text{ Btu}}{1 \text{ kJ}} \right) = 5.381 \text{ lbm/s}$$

The rate of heat addition is

$$\dot{Q}_{\text{in}} = \dot{m}(h_3 - h_2) = (5.381 \text{ lbm/s})(1363.1 - 98.52) \text{ Btu/lbm} \left(\frac{1 \text{ kJ}}{0.94782 \text{ Btu}} \right) = 6805 \text{ Btu/s}$$

and the thermal efficiency of the cycle is

$$\eta_{\text{th}} = \frac{\dot{W}_{\text{net}}}{\dot{Q}_{\text{in}}} = \frac{2500 \text{ kJ/s}}{6805 \text{ Btu/s}} \left(\frac{0.94782 \text{ Btu}}{1 \text{ kJ}} \right) = 0.3482$$

The thermal efficiency in the previous problem was determined to be 0.3446. The error in the thermal efficiency caused by neglecting the pump work is then

$$\text{Error} = \frac{0.3482 - 0.3446}{0.3446} \times 100 = \mathbf{1.03\%}$$

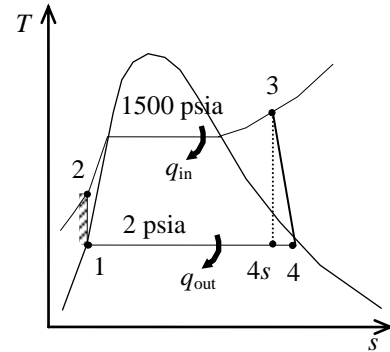

10-20E A steam power plant that operates on a simple ideal Rankine cycle between the specified pressure limits is considered. The minimum turbine inlet temperature, the rate of heat input in the boiler, and the thermal efficiency of the cycle are to be determined.

Assumptions 1 Steady operating conditions exist. 2 Kinetic and potential energy changes are negligible.

Analysis (a) From the steam tables (Tables A-4E, A-5E, and A-6E),

$$h_1 = h_f @ 2 \text{ psia} = 94.02 \text{ Btu/lbm}$$

$$v_1 = v_f @ 2 \text{ psia} = 0.01623 \text{ ft}^3/\text{lbm}$$

$$\begin{aligned} w_{p,\text{in}} &= v_1(P_2 - P_1) \\ &= (0.01623 \text{ ft}^3/\text{lbm})(1250 - 2 \text{ psia}) \left(\frac{1 \text{ Btu}}{5.4039 \text{ psia} \cdot \text{ft}^3} \right) \\ &= 3.75 \text{ Btu/lbm} \end{aligned}$$

$$h_2 = h_1 + w_{p,\text{in}} = 94.02 + 3.75 = 97.77 \text{ Btu/lbm}$$

$$h_4 = h_f + x_4 h_{fg} = 94.02 + (0.9)(1021.7) = 1013.6 \text{ Btu/lbm}$$

$$s_4 = s_f + x_4 s_{fg} = 0.17499 + (0.9)(1.74444) = 1.7450 \text{ Btu/lbm} \cdot \text{R}$$

$$\left. \begin{array}{l} P_3 = 1250 \text{ psia} \\ s_3 = s_4 \end{array} \right\} \begin{array}{l} h_3 = 1693.4 \text{ Btu/lbm} \\ T_3 = 1337^\circ\text{F} \end{array}$$

$$(b) \quad \dot{Q}_{\text{in}} = \dot{m}(h_3 - h_2) = (75 \text{ lbm/s})(1693.4 - 97.77) = \mathbf{119,672 \text{ Btu/s}}$$

$$(c) \quad \dot{Q}_{\text{out}} = \dot{m}(h_4 - h_1) = (75 \text{ lbm/s})(1013.6 - 94.02) = 68,967 \text{ Btu/s}$$

$$\eta_{\text{th}} = 1 - \frac{\dot{Q}_{\text{out}}}{\dot{Q}_{\text{in}}} = 1 - \frac{68,967 \text{ Btu/s}}{119,672 \text{ Btu/s}} = \mathbf{42.4\%}$$

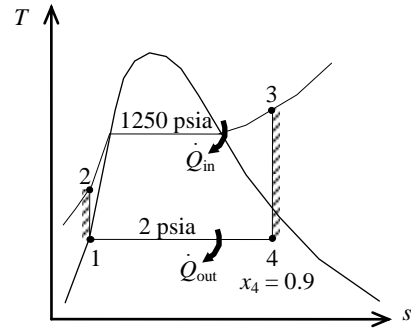

10-21E A steam power plant operates on a simple nonideal Rankine cycle between the specified pressure limits. The minimum turbine inlet temperature, the rate of heat input in the boiler, and the thermal efficiency of the cycle are to be determined.

Assumptions 1 Steady operating conditions exist. 2 Kinetic and potential energy changes are negligible.

Analysis (a) From the steam tables (Tables A-4E, A-5E, and A-6E),

$$h_1 = h_{f@ 2 \text{ psia}} = 94.02 \text{ Btu/lbm}$$

$$\nu_1 = \nu_{f@ 2 \text{ psia}} = 0.01623 \text{ ft}^3/\text{lbm}$$

$$\begin{aligned} w_{p,\text{in}} &= \nu_1 (P_2 - P_1) / \eta_P \\ &= (0.01623 \text{ ft}^3/\text{lbm})(1250 - 2 \text{ psia}) \left(\frac{1 \text{ Btu}}{5.4039 \text{ psia} \cdot \text{ft}^3} \right) / 0.85 \\ &= 4.41 \text{ Btu/lbm} \end{aligned}$$

$$h_2 = h_1 + w_{p,\text{in}} = 94.02 + 4.41 = 98.43 \text{ Btu/lbm}$$

$$h_4 = h_f + x_4 h_{fg} = 94.02 + (0.9)(1021.7) = 1013.6 \text{ Btu/lbm}$$

$$s_4 = s_f + x_4 s_{fg} = 0.17499 + (0.9)(1.74444) = 1.7450 \text{ Btu/lbm} \cdot \text{R}$$

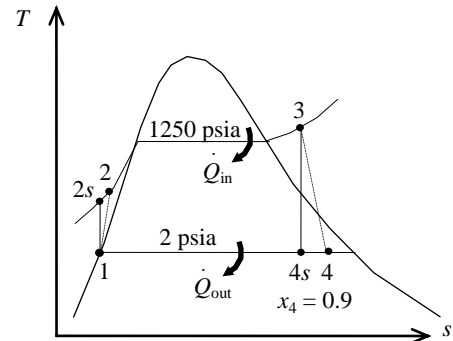

The turbine inlet temperature is determined by trial and error ,

$$\text{Try 1: } \left. \begin{array}{l} P_3 = 1250 \text{ psia} \\ T_3 = 900^\circ\text{F} \end{array} \right\} \begin{array}{l} h_3 = 1439.0 \text{ Btu/lbm} \\ s_3 = 1.5826 \text{ Btu/lbm} \cdot \text{R} \end{array}$$

$$x_{4s} = \frac{s_{4s} - s_f}{s_{fg}} = \frac{s_3 - s_f}{s_{fg}} = \frac{1.5826 - 0.17499}{1.74444} = 0.8069$$

$$h_{4s} = h_f + x_{4s} h_{fg} = 94.02 + (0.8069)(1021.7) = 918.4 \text{ Btu/lbm}$$

$$\eta_T = \frac{h_3 - h_4}{h_3 - h_{4s}} = \frac{1439.0 - 1013.6}{1439.0 - 918.4} = 0.8171$$

$$\text{Try 2: } \left. \begin{array}{l} P_3 = 1250 \text{ psia} \\ T_3 = 1000^\circ\text{F} \end{array} \right\} \begin{array}{l} h_3 = 1498.6 \text{ Btu/lbm} \\ s_3 = 1.6249 \text{ Btu/lbm} \cdot \text{R} \end{array}$$

$$x_{4s} = \frac{s_{4s} - s_f}{s_{fg}} = \frac{s_3 - s_f}{s_{fg}} = \frac{1.6249 - 0.17499}{1.74444} = 0.8312$$

$$h_{4s} = h_f + x_{4s} h_{fg} = 94.02 + (0.8312)(1021.7) = 943.3 \text{ Btu/lbm}$$

$$\eta_T = \frac{h_3 - h_4}{h_3 - h_{4s}} = \frac{1498.6 - 1013.6}{1498.6 - 943.3} = 0.8734$$

By linear interpolation, at $\eta_T = 0.85$ we obtain $T_3 = 958.4^\circ\text{F}$. This is approximate. We can determine state 3 exactly using EES software with these results: $T_3 = \mathbf{955.7^\circ\text{F}}$, $h_3 = 1472.5 \text{ Btu/lbm}$.

$$(b) \quad \dot{Q}_{\text{in}} = \dot{m}(h_3 - h_2) = (75 \text{ lbm/s})(1472.5 - 98.43) = \mathbf{103,055 \text{ Btu/s}}$$

$$(c) \quad \dot{Q}_{\text{out}} = \dot{m}(h_4 - h_1) = (75 \text{ lbm/s})(1013.6 - 94.02) = 68,969 \text{ Btu/s}$$

$$\eta_{\text{th}} = 1 - \frac{\dot{Q}_{\text{out}}}{\dot{Q}_{\text{in}}} = 1 - \frac{68,969 \text{ Btu/s}}{103,055 \text{ Btu/s}} = \mathbf{33.1\%}$$

10-22 A simple Rankine cycle with water as the working fluid operates between the specified pressure limits. The rate of heat addition in the boiler, the power input to the pumps, the net power, and the thermal efficiency of the cycle are to be determined.

Assumptions 1 Steady operating conditions exist. 2 Kinetic and potential energy changes are negligible.

Analysis From the steam tables (Tables A-4, A-5, and A-6),

$$\left. \begin{aligned} P_1 &= 50 \text{ kPa} \\ T_1 &= T_{\text{sat @ 50 kPa}} - 6.3 = 81.3 - 6.3 = 75^\circ\text{C} \end{aligned} \right\} \begin{aligned} h_1 &\cong h_f @ 75^\circ\text{C} = 314.03 \text{ kJ/kg} \\ \nu_1 &= \nu_f @ 75^\circ\text{C} = 0.001026 \text{ m}^3/\text{kg} \end{aligned}$$

$$\begin{aligned} w_{\text{p,in}} &= \nu_1 (P_2 - P_1) \\ &= (0.001026 \text{ m}^3/\text{kg})(6000 - 50) \text{ kPa} \left(\frac{1 \text{ kJ}}{1 \text{ kPa} \cdot \text{m}^3} \right) \\ &= 6.10 \text{ kJ/kg} \end{aligned}$$

$$h_2 = h_1 + w_{\text{p,in}} = 314.03 + 6.10 = 320.13 \text{ kJ/kg}$$

$$\left. \begin{aligned} P_3 &= 6000 \text{ kPa} \\ T_3 &= 450^\circ\text{C} \end{aligned} \right\} \begin{aligned} h_3 &= 3302.9 \text{ kJ/kg} \\ s_3 &= 6.7219 \text{ kJ/kg} \cdot \text{K} \end{aligned}$$

$$\left. \begin{aligned} P_4 &= 50 \text{ kPa} \\ s_4 &= s_3 \end{aligned} \right\} \begin{aligned} x_{4s} &= \frac{s_4 - s_f}{s_{fg}} = \frac{6.7219 - 1.0912}{6.5019} = 0.8660 \\ h_{4s} &= h_f + x_{4s} h_{fg} = 340.54 + (0.8660)(2304.7) = 2336.4 \text{ kJ/kg} \end{aligned}$$

$$\eta_T = \frac{h_3 - h_4}{h_3 - h_{4s}} \longrightarrow h_4 = h_3 - \eta_T (h_3 - h_{4s}) = 3302.9 - (0.94)(3302.9 - 2336.4) = 2394.4 \text{ kJ/kg}$$

Thus,

$$\begin{aligned} \dot{Q}_{\text{in}} &= \dot{m}(h_3 - h_2) = (20 \text{ kg/s})(3302.9 - 320.13) \text{ kJ/kg} = \mathbf{59,660 \text{ kW}} \\ \dot{W}_{\text{T,out}} &= \dot{m}(h_3 - h_4) = (20 \text{ kg/s})(3302.9 - 2394.4) \text{ kJ/kg} = 18,170 \text{ kW} \\ \dot{W}_{\text{P,in}} &= \dot{m} w_{\text{P,in}} = (20 \text{ kg/s})(6.10 \text{ kJ/kg}) = \mathbf{122 \text{ kW}} \\ \dot{W}_{\text{net}} &= \dot{W}_{\text{T,out}} - \dot{W}_{\text{P,in}} = 18,170 - 122 = \mathbf{18,050 \text{ kW}} \end{aligned}$$

and

$$\eta_{\text{th}} = \frac{\dot{W}_{\text{net}}}{\dot{Q}_{\text{in}}} = \frac{18,050}{59,660} = \mathbf{0.3025}$$

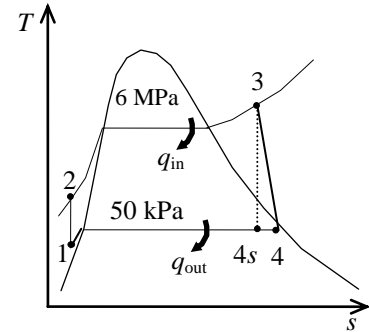



10-23 The change in the thermal efficiency of the cycle in Prob. 10-22 due to a pressure drop in the boiler is to be determined.

Analysis We use the following EES routine to obtain the solution.

"Given"

```
P[2]=6000 [kPa]
DELTAP=50 [kPa]
P[3]=6000-DELTAP [kPa]
T[3]=450 [C]
P[4]=50 [kPa]
Eta_T=0.94
DELTAT_subcool=6.3 [C]
T[1]=temperature(Fluid$, P=P[1], x=x[1])-DELTAT_subcool
m_dot=20 [kg/s]
```

"Analysis"

```
Fluid$='steam_iapws'
P[1]=P[4]
x[1]=0
h[1]=enthalpy(Fluid$, P=P[1], T=T[1])
v[1]=volume(Fluid$, P=P[1], T=T[1])
w_p_in=v[1]*(P[2]-P[1])
h[2]=h[1]+w_p_in
h[3]=enthalpy(Fluid$, P=P[3], T=T[3])
s[3]=entropy(Fluid$, P=P[3], T=T[3])
s[4]=s[3]
h_s[4]=enthalpy(Fluid$, P=P[4], s=s[4])
Eta_T=(h[3]-h[4])/(h[3]-h_s[4])
q_in=h[3]-h[2]
q_out=h[4]-h[1]
w_net=q_in-q_out
Eta_th=1-q_out/q_in
```

Solution

DELTAP=50 [kPa]	DELTAT_subcool=6.3 [C]	Eta_T=0.94
Eta_th= 0.3022	Fluid\$='steam_iapws'	h[1]=314.11 [kJ/kg]
h[2]=320.21 [kJ/kg]	h[3]=3303.64 [kJ/kg]	h[4]=2396.01 [kJ/kg]
h_s[4]=2338.1 [kJ/kg]	m_dot=20 [kg/s]	P[1]=50
P[2]=6000	P[3]=5950	P[4]=50
q_in=2983.4 [kJ/kg]	q_out=2081.9 [kJ/kg]	s[3]=6.7265 [kJ/kg-K]
s[4]=6.7265 [kJ/kg-K]	T[1]=75.02 [C]	T[3]=450 [C]
v[1]=0.001026 [m ³ /kg]	w_net=901.5 [kJ/kg]	w_p_in=6.104 [kJ/kg]
x[1]=0		

Discussion The thermal efficiency without a pressure drop was obtained to be 0.3025.

10-24 The net work outputs and the thermal efficiencies for a Carnot cycle and a simple ideal Rankine cycle are to be determined.

Assumptions 1 Steady operating conditions exist. **2** Kinetic and potential energy changes are negligible.

Analysis (a) Rankine cycle analysis: From the steam tables (Tables A-4, A-5, and A-6),

$$h_1 = h_f @ 50 \text{ kPa} = 340.54 \text{ kJ/kg}$$

$$v_1 = v_f @ 50 \text{ kPa} = 0.001030 \text{ m}^3/\text{kg}$$

$$\begin{aligned} w_{p,\text{in}} &= v_1(P_2 - P_1) \\ &= (0.001030 \text{ m}^3/\text{kg})(5000 - 50) \text{ kPa} \left(\frac{1 \text{ kJ}}{1 \text{ kPa} \cdot \text{m}^3} \right) \\ &= 5.10 \text{ kJ/kg} \end{aligned}$$

$$h_2 = h_1 + w_{p,\text{in}} = 340.54 + 5.10 = 345.64 \text{ kJ/kg}$$

$$\left. \begin{array}{l} P_3 = 5 \text{ MPa} \\ x_3 = 1 \end{array} \right\} \begin{array}{l} h_3 = 2794.2 \text{ kJ/kg} \\ s_3 = 5.9737 \text{ kJ/kg} \cdot \text{K} \end{array}$$

$$\left. \begin{array}{l} P_4 = 50 \text{ kPa} \\ s_4 = s_3 \end{array} \right\} x_4 = \frac{s_4 - s_f}{s_{fg}} = \frac{5.9737 - 1.09120}{6.5019} = 0.7509$$

$$\begin{aligned} h_4 &= h_f + x_4 h_{fg} = 340.54 + (0.7509)(2304.7) \\ &= 2071.2 \text{ kJ/kg} \end{aligned}$$

$$q_{\text{in}} = h_3 - h_2 = 2794.2 - 345.64 = 2448.6 \text{ kJ/kg}$$

$$q_{\text{out}} = h_4 - h_1 = 2071.2 - 340.54 = 1730.7 \text{ kJ/kg}$$

$$w_{\text{net}} = q_{\text{in}} - q_{\text{out}} = 2448.6 - 1730.7 = \mathbf{717.9 \text{ kJ/kg}}$$

$$\eta_{\text{th}} = 1 - \frac{q_{\text{out}}}{q_{\text{in}}} = 1 - \frac{1730.7}{2448.6} = 0.2932 = \mathbf{29.3\%}$$

(b) Carnot Cycle analysis:

$$\left. \begin{array}{l} P_3 = 5 \text{ MPa} \\ x_3 = 1 \end{array} \right\} \begin{array}{l} h_3 = 2794.2 \text{ kJ/kg} \\ T_3 = 263.9^\circ\text{C} \end{array}$$

$$\left. \begin{array}{l} T_2 = T_3 = 263.9^\circ\text{C} \\ x_2 = 0 \end{array} \right\} \begin{array}{l} h_2 = 1154.5 \text{ kJ/kg} \\ s_2 = 2.9207 \text{ kJ/kg} \cdot \text{K} \end{array}$$

$$\left. \begin{array}{l} P_1 = 50 \text{ kPa} \\ s_1 = s_2 \end{array} \right\} x_1 = \frac{s_1 - s_f}{s_{fg}} = \frac{2.9207 - 1.0912}{6.5019} = 0.2814$$

$$\begin{aligned} h_1 &= h_f + x_1 h_{fg} \\ &= 340.54 + (0.2814)(2304.7) = 989.05 \text{ kJ/kg} \end{aligned}$$

$$q_{\text{in}} = h_3 - h_2 = 2794.2 - 1154.5 = 1639.7 \text{ kJ/kg}$$

$$q_{\text{out}} = h_4 - h_1 = 2071.2 - 340.54 = 1082.2 \text{ kJ/kg}$$

$$w_{\text{net}} = q_{\text{in}} - q_{\text{out}} = 1639.7 - 1082.2 = \mathbf{557.5 \text{ kJ/kg}}$$

$$\eta_{\text{th}} = 1 - \frac{q_{\text{out}}}{q_{\text{in}}} = 1 - \frac{1082.2}{1639.7} = 0.3400 = \mathbf{34.0\%}$$

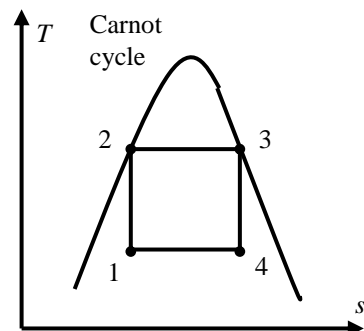
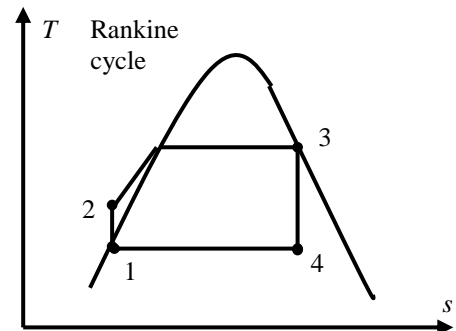

10-25 A binary geothermal power operates on the simple Rankine cycle with isobutane as the working fluid. The isentropic efficiency of the turbine, the net power output, and the thermal efficiency of the cycle are to be determined.

Assumptions 1 Steady operating conditions exist. 2 Kinetic and potential energy changes are negligible.

Properties The specific heat of geothermal water is taken to be 4.18 kJ/kg·°C.

Analysis (a) We need properties of isobutane, which are not available in the book. However, we can obtain the properties from EES.

Turbine:

$$\left. \begin{array}{l} P_3 = 3250 \text{ kPa} \\ T_3 = 147^\circ\text{C} \end{array} \right\} \begin{array}{l} h_3 = 761.54 \text{ kJ/kg} \\ s_3 = 2.5457 \text{ kJ/kg}\cdot\text{K} \end{array}$$

$$\left. \begin{array}{l} P_4 = 410 \text{ kPa} \\ s_4 = s_3 \end{array} \right\} h_{4s} = 670.40 \text{ kJ/kg}$$

$$\left. \begin{array}{l} P_4 = 410 \text{ kPa} \\ T_4 = 179.5^\circ\text{C} \end{array} \right\} h_4 = 689.74 \text{ kJ/kg}$$

$$\eta_T = \frac{h_3 - h_4}{h_3 - h_{4s}} = \frac{761.54 - 689.74}{761.54 - 670.40} = \mathbf{0.788}$$

(b) Pump:

$$h_1 = h_f @ 410 \text{ kPa} = 273.01 \text{ kJ/kg}$$

$$v_1 = v_f @ 410 \text{ kPa} = 0.001842 \text{ m}^3/\text{kg}$$

$$\begin{aligned} w_{p,\text{in}} &= v_1(P_2 - P_1)/\eta_P \\ &= (0.001842 \text{ m}^3/\text{kg})(3250 - 410) \text{ kPa} \left(\frac{1 \text{ kJ}}{1 \text{ kPa}\cdot\text{m}^3} \right) / 0.90 \\ &= 5.81 \text{ kJ/kg} \end{aligned}$$

$$h_2 = h_1 + w_{p,\text{in}} = 273.01 + 5.81 = 278.82 \text{ kJ/kg}$$

$$\dot{W}_{T,\text{out}} = \dot{m}(h_3 - h_4) = (305.6 \text{ kJ/kg})(761.54 - 689.74) \text{ kJ/kg} = 21,941 \text{ kW}$$

$$\dot{W}_{P,\text{in}} = \dot{m}(h_2 - h_1) = \dot{m}w_{p,\text{in}} = (305.6 \text{ kJ/kg})(5.81 \text{ kJ/kg}) = 1777 \text{ kW}$$

$$\dot{W}_{\text{net}} = \dot{W}_{T,\text{out}} - \dot{W}_{P,\text{in}} = 21,941 - 1777 = \mathbf{20,165 \text{ kW}}$$

Heat Exchanger:

$$\dot{Q}_{\text{in}} = \dot{m}_{\text{geo}} c_{\text{geo}}(T_{\text{in}} - T_{\text{out}}) = (555.9 \text{ kJ/kg})(4.18 \text{ kJ/kg}\cdot^\circ\text{C})(160 - 90)^\circ\text{C} = 162,656 \text{ kW}$$

$$(c) \quad \eta_{\text{th}} = \frac{\dot{W}_{\text{net}}}{\dot{Q}_{\text{in}}} = \frac{20,165}{162,656} = \mathbf{0.124 = 12.4\%}$$

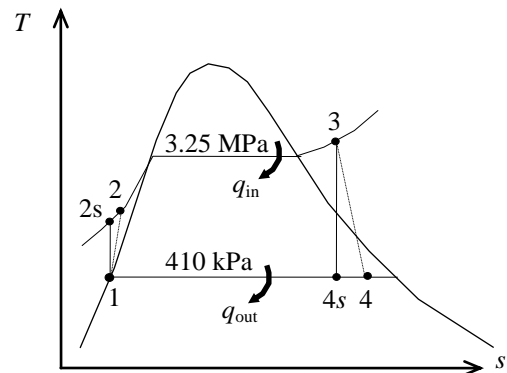
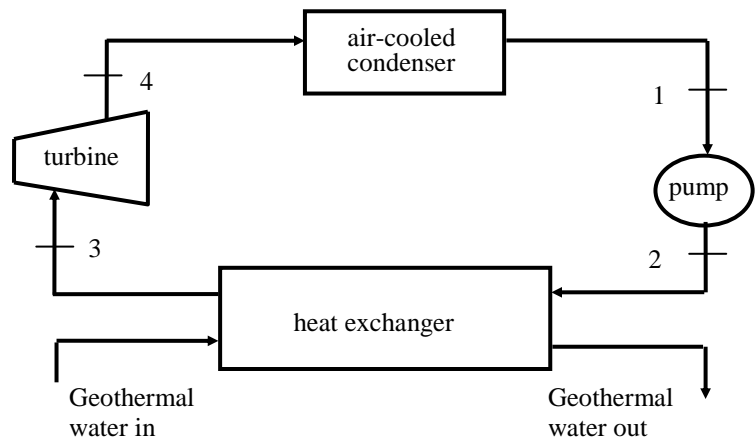

10-26 A 175-MW coal-fired steam power plant operates on a simple ideal Rankine cycle between the specified pressure limits. The overall plant efficiency and the required rate of the coal supply are to be determined.

Assumptions 1 Steady operating conditions exist. 2 Kinetic and potential energy changes are negligible.

Analysis (a) From the steam tables (Tables A-4, A-5, and A-6),

$$h_1 = h_f @ 15 \text{ kPa} = 225.94 \text{ kJ/kg}$$

$$v_1 = v_f @ 15 \text{ kPa} = 0.0010140 \text{ m}^3/\text{kg}$$

$$\begin{aligned} w_{p,\text{in}} &= v_1(P_2 - P_1) \\ &= (0.001014 \text{ m}^3/\text{kg})(7000 - 15 \text{ kPa}) \left(\frac{1 \text{ kJ}}{1 \text{ kPa} \cdot \text{m}^3} \right) \\ &= 7.08 \text{ kJ/kg} \end{aligned}$$

$$h_2 = h_1 + w_{p,\text{in}} = 225.94 + 7.08 = 233.03 \text{ kJ/kg}$$

$$\left. \begin{array}{l} P_3 = 7 \text{ MPa} \\ T_3 = 550^\circ\text{C} \end{array} \right\} \begin{array}{l} h_3 = 3531.6 \text{ kJ/kg} \\ s_3 = 6.9507 \text{ kJ/kg} \cdot \text{K} \end{array}$$

$$\left. \begin{array}{l} P_4 = 15 \text{ kPa} \\ s_4 = s_3 \end{array} \right\} x_4 = \frac{s_4 - s_f}{s_{fg}} = \frac{6.9507 - 0.7549}{7.2522} = 0.8543$$

$$h_4 = h_f + x_4 h_{fg} = 225.94 + (0.8543)(2372.4) = 2252.7 \text{ kJ/kg}$$

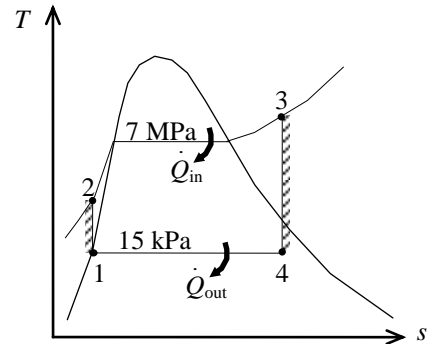

The thermal efficiency is determined from

$$q_{\text{in}} = h_3 - h_2 = 3531.6 - 233.03 = 3298.6 \text{ kJ/kg}$$

$$q_{\text{out}} = h_4 - h_1 = 2252.7 - 225.94 = 2026.8 \text{ kJ/kg}$$

and

$$\eta_{\text{th}} = 1 - \frac{q_{\text{out}}}{q_{\text{in}}} = 1 - \frac{2026.8}{3298.6} = 0.3856$$

Thus,

$$\eta_{\text{overall}} = \eta_{\text{th}} \times \eta_{\text{comb}} \times \eta_{\text{gen}} = (0.3856)(0.85)(0.96) = 0.3146 = \mathbf{31.5\%}$$

(b) Then the required rate of coal supply becomes

$$\dot{Q}_{\text{in}} = \frac{\dot{W}_{\text{net}}}{\eta_{\text{overall}}} = \frac{175,000 \text{ kJ/s}}{0.3146} = 556,220 \text{ kJ/s}$$

and

$$\dot{m}_{\text{coal}} = \frac{\dot{Q}_{\text{in}}}{\text{HV}_{\text{coal}}} = \frac{556,220 \text{ kJ/s}}{29,300 \text{ kJ/kg}} = 18.98 \text{ kg/s} = \mathbf{68.3 \text{ tons/h}}$$

The Reheat Rankine Cycle

10-27C The T - s diagram of the ideal Rankine cycle with 3 stages of reheat is shown on the side. The cycle efficiency will increase as the number of reheating stages increases.

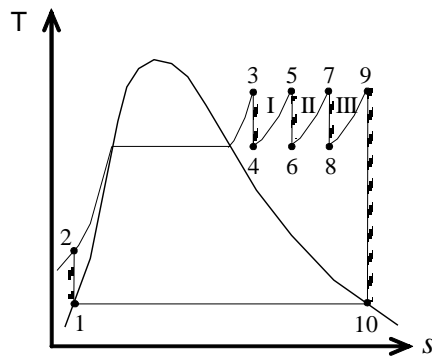

10-28C The pump work remains the same, the moisture content decreases, everything else increases.

10-29C The thermal efficiency of the simple ideal Rankine cycle will probably be higher since the average temperature at which heat is added will be higher in this case.

10-30 An ideal reheat steam Rankine cycle produces 2000 kW power. The mass flow rate of the steam, the rate of heat transfer in the reheater, the power used by the pumps, and the thermal efficiency of the cycle are to be determined.

Assumptions 1 Steady operating conditions exist. 2 Kinetic and potential energy changes are negligible.

Analysis From the steam tables (Tables A-4, A-5, and A-6 or EES),

$$h_1 = h_f @ 100 \text{ kPa} = 417.51 \text{ kJ/kg}$$

$$v_1 = v_f @ 100 \text{ kPa} = 0.001043 \text{ m}^3/\text{kg}$$

$$w_{p,\text{in}} = v_1 (P_2 - P_1) \\ = (0.001043 \text{ m}^3/\text{kg})(15000 - 100) \text{ kPa} \left(\frac{1 \text{ kJ}}{1 \text{ kPa} \cdot \text{m}^3} \right) \\ = 15.54 \text{ kJ/kg}$$

$$h_2 = h_1 + w_{p,\text{in}} = 417.51 + 15.54 = 433.05 \text{ kJ/kg}$$

$$\left. \begin{array}{l} P_3 = 15,000 \text{ kPa} \\ T_3 = 450^\circ\text{C} \end{array} \right\} \begin{array}{l} h_3 = 3157.9 \text{ kJ/kg} \\ s_3 = 6.1434 \text{ kJ/kg} \cdot \text{K} \end{array}$$

$$\left. \begin{array}{l} P_4 = 2000 \text{ kPa} \\ s_4 = s_3 \end{array} \right\} \begin{array}{l} x_4 = \frac{s_4 - s_f}{s_{fg}} = \frac{6.1434 - 2.4467}{3.8923} = 0.9497 \\ h_4 = h_f + x_4 h_{fg} = 908.47 + (0.9497)(1889.8) = 2703.3 \text{ kJ/kg} \end{array}$$

$$\left. \begin{array}{l} P_5 = 2000 \text{ kPa} \\ T_5 = 450^\circ\text{C} \end{array} \right\} \begin{array}{l} h_5 = 3358.2 \text{ kJ/kg} \\ s_5 = 7.2866 \text{ kJ/kg} \cdot \text{K} \end{array}$$

$$\left. \begin{array}{l} P_6 = 100 \text{ kPa} \\ s_6 = s_5 \end{array} \right\} \begin{array}{l} x_6 = \frac{s_6 - s_f}{s_{fg}} = \frac{7.2866 - 1.3028}{6.0562} = 0.9880 \\ h_6 = h_f + x_6 h_{fg} = 417.51 + (0.9880)(22257.5) = 2648.0 \text{ kJ/kg} \end{array}$$

Thus,

$$q_{\text{in}} = (h_3 - h_2) + (h_5 - h_4) = 3157.9 - 433.05 + 3358.2 - 2703.3 = 3379.8 \text{ kJ/kg}$$

$$q_{\text{out}} = h_6 - h_1 = 2648.0 - 417.51 = 2230.5 \text{ kJ/kg}$$

$$w_{\text{net}} = q_{\text{in}} - q_{\text{out}} = 3379.8 - 2230.5 = 1149.2 \text{ kJ/kg}$$

The power produced by the cycle is

$$\dot{W}_{\text{net}} = \dot{m} w_{\text{net}} = (1.74 \text{ kg/s})(1149.2 \text{ kJ/kg}) = \mathbf{2000 \text{ kW}}$$

The rate of heat transfer in the reheater is

$$\dot{Q}_{\text{reheater}} = \dot{m}(h_5 - h_4) = (1.740 \text{ kg/s})(3358.2 - 2703.3) \text{ kJ/kg} = \mathbf{1140 \text{ kW}}$$

$$\dot{W}_{P,\text{in}} = \dot{m} w_{P,\text{in}} = (1.740 \text{ kg/s})(15.54 \text{ kJ/kg}) = \mathbf{27 \text{ kW}}$$

and the thermal efficiency of the cycle is

$$\eta_{\text{th}} = 1 - \frac{q_{\text{out}}}{q_{\text{in}}} = 1 - \frac{2230.5}{3379.8} = \mathbf{0.340}$$

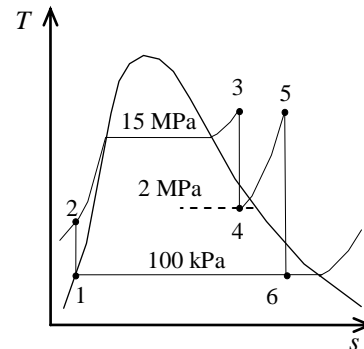



10-31 A steam power plant that operates on the ideal reheat Rankine cycle is considered. The turbine work output and the thermal efficiency of the cycle are to be determined.

Assumptions 1 Steady operating conditions exist. 2 Kinetic and potential energy changes are negligible.

Analysis From the steam tables (Tables A-4, A-5, and A-6),

$$h_1 = h_f @ 20 \text{ kPa} = 251.42 \text{ kJ/kg}$$

$$v_1 = v_f @ 20 \text{ kPa} = 0.001017 \text{ m}^3/\text{kg}$$

$$\begin{aligned} w_{p,\text{in}} &= v_1 (P_2 - P_1) \\ &= (0.001017 \text{ m}^3/\text{kg})(6000 - 20 \text{ kPa}) \left(\frac{1 \text{ kJ}}{1 \text{ kPa} \cdot \text{m}^3} \right) \\ &= 6.08 \text{ kJ/kg} \end{aligned}$$

$$h_2 = h_1 + w_{p,\text{in}} = 251.42 + 6.08 = 257.50 \text{ kJ/kg}$$

$$\left. \begin{array}{l} P_3 = 6 \text{ MPa} \\ T_3 = 400^\circ\text{C} \end{array} \right\} \begin{array}{l} h_3 = 3178.3 \text{ kJ/kg} \\ s_3 = 6.5432 \text{ kJ/kg} \cdot \text{K} \end{array}$$

$$\left. \begin{array}{l} P_4 = 2 \text{ MPa} \\ s_4 = s_3 \end{array} \right\} h_4 = 2901.0 \text{ kJ/kg}$$

$$\left. \begin{array}{l} P_5 = 2 \text{ MPa} \\ T_5 = 400^\circ\text{C} \end{array} \right\} \begin{array}{l} h_5 = 3248.4 \text{ kJ/kg} \\ s_5 = 7.1292 \text{ kJ/kg} \cdot \text{K} \end{array}$$

$$\left. \begin{array}{l} P_6 = 20 \text{ kPa} \\ s_6 = s_5 \end{array} \right\} \begin{array}{l} x_6 = \frac{s_6 - s_f}{s_{fg}} = \frac{7.1292 - 0.8320}{7.0752} = 0.8900 \\ h_6 = h_f + x_6 h_{fg} = 251.42 + (0.8900)(2357.5) = 2349.7 \text{ kJ/kg} \end{array}$$

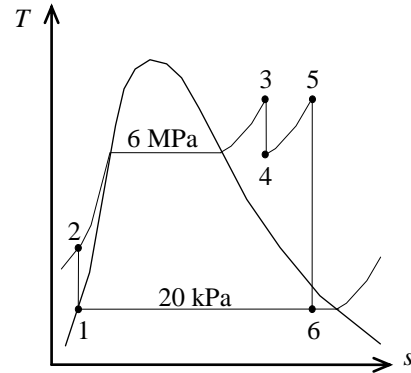

The turbine work output and the thermal efficiency are determined from

$$w_{T,\text{out}} = (h_3 - h_4) + (h_5 - h_6) = 3178.3 - 2901.0 + 3248.4 - 2349.7 = \mathbf{1176 \text{ kJ/kg}}$$

and

$$q_{\text{in}} = (h_3 - h_2) + (h_5 - h_4) = 3178.3 - 257.50 + 3248.4 - 2901.0 = 3268 \text{ kJ/kg}$$

$$w_{\text{net}} = w_{T,\text{out}} - w_{p,\text{in}} = 1176 - 6.08 = 1170 \text{ kJ/kg}$$

Thus,

$$\eta_{\text{th}} = \frac{w_{\text{net}}}{q_{\text{in}}} = \frac{1170 \text{ kJ/kg}}{3268 \text{ kJ/kg}} = 0.358 = \mathbf{35.8\%}$$



10-32 Problem 10-31 is reconsidered. The problem is to be solved by the diagram window data entry feature of EES by including the effects of the turbine and pump efficiencies and reheat on the steam quality at the low-pressure turbine exit. Also, the T - s diagram is to be plotted.

Analysis The problem is solved using EES, and the solution is given below.

"Input Data - from diagram window"

```
{P[6] = 20 [kPa]
P[3] = 6000 [kPa]
T[3] = 400 [C]
P[4] = 2000 [kPa]
T[5] = 400 [C]
Eta_t = 100/100 "Turbine isentropic efficiency"
Eta_p = 100/100 "Pump isentropic efficiency"}
```

"Pump analysis"

```
function x6$(x6) "this function returns a string to indicate the state of steam at point 6"
    x6$=""
    if (x6>1) then x6$='(superheated)'
    if (x6<0) then x6$='(subcooled)'
end
```

Fluid\$='Steam_IAPWS'

```
P[1] = P[6]
P[2]=P[3]
x[1]=0 "Sat'd liquid"
h[1]=enthalpy(Fluid$,P=P[1],x=x[1])
v[1]=volume(Fluid$,P=P[1],x=x[1])
s[1]=entropy(Fluid$,P=P[1],x=x[1])
T[1]=temperature(Fluid$,P=P[1],x=x[1])
W_p_s=v[1]*(P[2]-P[1])"SSSF isentropic pump work assuming constant specific volume"
W_p=W_p_s/Eta_p
h[2]=h[1]+W_p "SSSF First Law for the pump"
v[2]=volume(Fluid$,P=P[2],h=h[2])
s[2]=entropy(Fluid$,P=P[2],h=h[2])
T[2]=temperature(Fluid$,P=P[2],h=h[2])
"High Pressure Turbine analysis"
h[3]=enthalpy(Fluid$,T=T[3],P=P[3])
s[3]=entropy(Fluid$,T=T[3],P=P[3])
v[3]=volume(Fluid$,T=T[3],P=P[3])
s_s[4]=s[3]
hs[4]=enthalpy(Fluid$,s=s_s[4],P=P[4])
Ts[4]=temperature(Fluid$,s=s_s[4],P=P[4])
Eta_t=(h[3]-h[4])/(h[3]-hs[4])"Definition of turbine efficiency"
T[4]=temperature(Fluid$,P=P[4],h=h[4])
s[4]=entropy(Fluid$,T=T[4],P=P[4])
v[4]=volume(Fluid$,s=s[4],P=P[4])
h[3] =W_t_hp+h[4]"SSSF First Law for the high pressure turbine"
"Low Pressure Turbine analysis"
P[5]=P[4]
s[5]=entropy(Fluid$,T=T[5],P=P[5])
h[5]=enthalpy(Fluid$,T=T[5],P=P[5])
s_s[6]=s[5]
hs[6]=enthalpy(Fluid$,s=s_s[6],P=P[6])
Ts[6]=temperature(Fluid$,s=s_s[6],P=P[6])
vs[6]=volume(Fluid$,s=s_s[6],P=P[6])
Eta_t=(h[5]-h[6])/(h[5]-hs[6])"Definition of turbine efficiency"
h[5]=W_t_lp+h[6]"SSSF First Law for the low pressure turbine"
```

$x[6]=\text{QUALITY}(\text{Fluid}\$,h=h[6],P=P[6])$

"Boiler analysis"

$Q_{in} + h[2]+h[4]=h[3]+h[5]$ "SSSF First Law for the Boiler"

"Condenser analysis"

$h[6]=Q_{out}+h[1]$ "SSSF First Law for the Condenser"

$T[6]=\text{temperature}(\text{Fluid}\$,h=h[6],P=P[6])$

$s[6]=\text{entropy}(\text{Fluid}\$,h=h[6],P=P[6])$

$x6s\$=x6\$(x[6])$

"Cycle Statistics"

$W_{net}=W_{t_hp}+W_{t_lp}-W_{p}$

$Eff=W_{net}/Q_{in}$

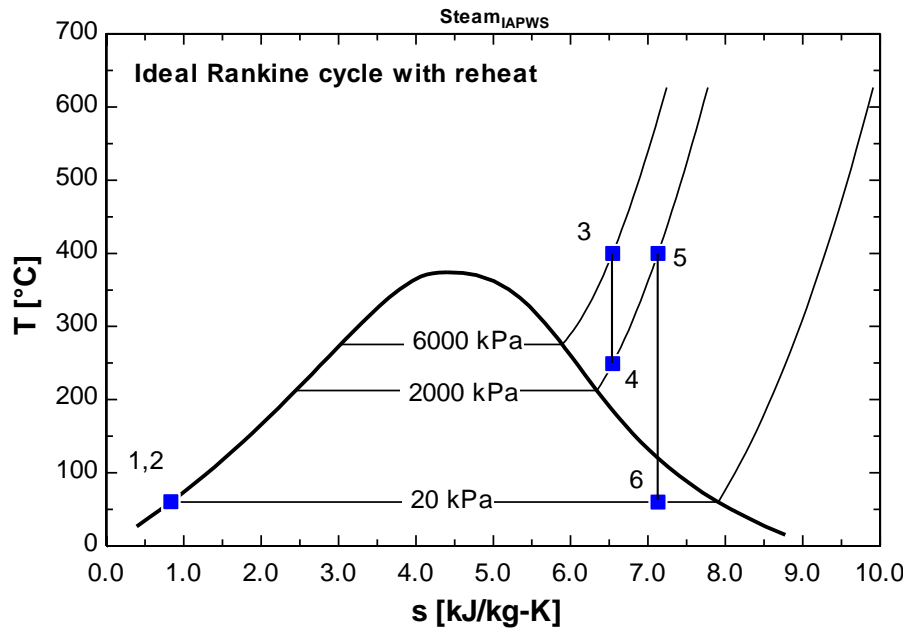

SOLUTION

$Eff=0.358$

$Eta_p=1$

$Eta_t=1$

$\text{Fluid}\$='Steam_IAPWS'$

$Q_{in}=3268$ [kJ/kg]

$Q_{out}=2098$ [kJ/kg]

$W_{net}=1170$ [kJ/kg]

$W_p=6.083$ [kJ/kg]

$W_{p_s}=6.083$ [kJ/kg]

$W_{t_hp}=277.2$ [kJ/kg]

$W_{t_lp}=898.7$ [kJ/kg]

$x6s\$=''$

10-33E A steam power plant that operates on the ideal reheat Rankine cycle is considered. The pressure at which reheating takes place, the net power output, the thermal efficiency, and the minimum mass flow rate of the cooling water required are to be determined.

Assumptions 1 Steady operating conditions exist. 2 Kinetic and potential energy changes are negligible.

Analysis (a) From the steam tables (Tables A-4E, A-5E, and A-6E),

$$\begin{aligned}
 h_1 &= h_{\text{sat}@ 1 \text{ psia}} = 69.72 \text{ Btu/lbm} \\
 v_1 &= v_{\text{sat}@ 1 \text{ psia}} = 0.01614 \text{ ft}^3/\text{lbm} \\
 T_1 &= T_{\text{sat}@ 1 \text{ psia}} = 101.69^\circ\text{F} \\
 w_{p,\text{in}} &= v_1(P_2 - P_1) \\
 &= (0.01614 \text{ ft}^3/\text{lbm})(800 - 1 \text{ psia}) \left(\frac{1 \text{ Btu}}{5.4039 \text{ psia} \cdot \text{ft}^3} \right) \\
 &= 2.39 \text{ Btu/lbm} \\
 h_2 &= h_1 + w_{p,\text{in}} = 69.72 + 2.39 = 72.11 \text{ Btu/lbm} \\
 P_3 = 800 \text{ psia} & \left. \begin{array}{l} h_3 = 1456.0 \text{ Btu/lbm} \\ T_3 = 900^\circ\text{F} \end{array} \right\} s_3 = 1.6413 \text{ Btu/lbm} \cdot \text{R} \\
 s_4 = s_3 & \left. \begin{array}{l} h_4 = h_g@ s_g = s_4 = 1178.5 \text{ Btu/lbm} \\ (\text{sat. vapor}) \left. \begin{array}{l} P_4 = P_{\text{sat}@ s_g = s_4} = \mathbf{62.23 \text{ psia}} \text{ (thereheat pressure)} \end{array} \right\} \end{array} \right. \\
 P_5 = 62.23 \text{ psia} & \left. \begin{array}{l} h_5 = 1431.4 \text{ Btu/lbm} \\ T_5 = 800^\circ\text{F} \end{array} \right\} s_5 = 1.8985 \text{ Btu/lbm} \cdot \text{R} \\
 P_6 = 1 \text{ psia} & \left. \begin{array}{l} x_6 = \frac{s_6 - s_f}{s_{fg}} = \frac{1.8985 - 0.13262}{1.84495} = 0.9572 \\ s_6 = s_5 \end{array} \right\} h_6 = h_f + x_6 h_{fg} = 69.72 + (0.9572)(1035.7) = 1061.0 \text{ Btu/lbm}
 \end{aligned}$$

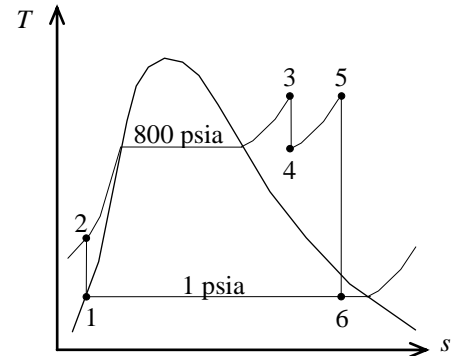

$$(b) \quad q_{\text{in}} = (h_3 - h_2) + (h_5 - h_4) = 1456.0 - 72.11 + 1431.4 - 1178.5 = 1636.8 \text{ Btu/lbm}$$

$$q_{\text{out}} = h_6 - h_1 = 1061.0 - 69.72 = 991.3 \text{ Btu/lbm}$$

Thus,

$$\eta_{\text{th}} = 1 - \frac{q_{\text{out}}}{q_{\text{in}}} = 1 - \frac{991.3 \text{ Btu/lbm}}{1636.8 \text{ Btu/lbm}} = \mathbf{39.4\%}$$

(c) The mass flow rate of the cooling water will be minimum when it is heated to the temperature of the steam in the condenser, which is 101.7°F ,

$$\begin{aligned}
 \dot{Q}_{\text{out}} &= \dot{Q}_{\text{in}} - \dot{W}_{\text{net}} = (1 - \eta_{\text{th}}) \dot{Q}_{\text{in}} = (1 - 0.3943)(6 \times 10^4 \text{ Btu/s}) = 3.634 \times 10^4 \text{ Btu/s} \\
 \dot{m}_{\text{cool}} &= \frac{\dot{Q}_{\text{out}}}{c \Delta T} = \frac{3.634 \times 10^4 \text{ Btu/s}}{(1.0 \text{ Btu/lbm} \cdot ^\circ\text{F})(101.69 - 45)^\circ\text{F}} = \mathbf{641.0 \text{ lbm/s}}
 \end{aligned}$$

10-34 An ideal reheat Rankine with water as the working fluid is considered. The temperatures at the inlet of both turbines, and the thermal efficiency of the cycle are to be determined.

Assumptions 1 Steady operating conditions exist. **2** Kinetic and potential energy changes are negligible.

Analysis From the steam tables (Tables A-4, A-5, and A-6),

$$h_1 = h_f @ 20 \text{ kPa} = 251.42 \text{ kJ/kg}$$

$$v_1 = v_f @ 20 \text{ kPa} = 0.0010172 \text{ m}^3/\text{kg}$$

$$\begin{aligned} w_{p,\text{in}} &= v_1(P_2 - P_1) \\ &= (0.0010172 \text{ m}^3/\text{kg})(5000 - 20) \text{ kPa} \left(\frac{1 \text{ kJ}}{1 \text{ kPa} \cdot \text{m}^3} \right) \\ &= 5.065 \text{ kJ/kg} \end{aligned}$$

$$h_2 = h_1 + w_{p,\text{in}} = 251.42 + 5.065 = 256.49 \text{ kJ/kg}$$

$$\left. \begin{array}{l} P_4 = 1200 \text{ kPa} \\ x_4 = 0.96 \end{array} \right\} \begin{array}{l} h_4 = h_f + x_4 h_{fg} = 798.33 + (0.96)(1985.4) = 2704.3 \text{ kJ/kg} \\ s_4 = s_f + x_4 s_{fg} = 2.2159 + (0.96)(4.3058) = 6.3495 \text{ kJ/kg} \cdot \text{K} \end{array}$$

$$\left. \begin{array}{l} P_3 = 5000 \text{ kPa} \\ s_3 = s_4 \end{array} \right\} \begin{array}{l} h_3 = 3006.9 \text{ kJ/kg} \\ T_3 = \mathbf{327.2^\circ\text{C}} \end{array}$$

$$\left. \begin{array}{l} P_6 = 20 \text{ kPa} \\ x_6 = 0.96 \end{array} \right\} \begin{array}{l} h_6 = h_f + x_6 h_{fg} = 251.42 + (0.96)(2357.5) = 2514.6 \text{ kJ/kg} \\ s_6 = s_f + x_6 s_{fg} = 0.8320 + (0.96)(7.0752) = 7.6242 \text{ kJ/kg} \cdot \text{K} \end{array}$$

$$\left. \begin{array}{l} P_5 = 1200 \text{ kPa} \\ s_5 = s_6 \end{array} \right\} \begin{array}{l} h_5 = 3436.0 \text{ kJ/kg} \\ T_5 = \mathbf{481.1^\circ\text{C}} \end{array}$$

Thus,

$$q_{\text{in}} = (h_3 - h_2) + (h_5 - h_4) = 3006.9 - 256.49 + 3436.0 - 2704.3 = 3482.0 \text{ kJ/kg}$$

$$q_{\text{out}} = h_6 - h_1 = 2514.6 - 251.42 = 2263.2 \text{ kJ/kg}$$

and

$$\eta_{\text{th}} = 1 - \frac{q_{\text{out}}}{q_{\text{in}}} = 1 - \frac{2263.2}{3482.0} = 0.3500 = \mathbf{35.0\%}$$

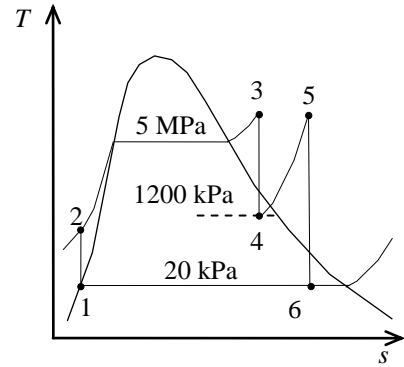

10-35 A steam power plant that operates on an ideal reheat Rankine cycle between the specified pressure limits is considered. The pressure at which reheating takes place, the total rate of heat input in the boiler, and the thermal efficiency of the cycle are to be determined.

Assumptions 1 Steady operating conditions exist. 2 Kinetic and potential energy changes are negligible.

Analysis (a) From the steam tables (Tables A-4, A-5, and A-6),

$$h_1 = h_{\text{sat}@ 10 \text{ kPa}} = 191.81 \text{ kJ/kg}$$

$$v_1 = v_{\text{sat}@ 10 \text{ kPa}} = 0.00101 \text{ m}^3/\text{kg}$$

$$\begin{aligned} w_{p,\text{in}} &= v_1(P_2 - P_1) \\ &= (0.00101 \text{ m}^3/\text{kg})(15,000 - 10 \text{ kPa}) \left(\frac{1 \text{ kJ}}{1 \text{ kPa} \cdot \text{m}^3} \right) \\ &= 15.14 \text{ kJ/kg} \end{aligned}$$

$$h_2 = h_1 + w_{p,\text{in}} = 191.81 + 15.14 = 206.95 \text{ kJ/kg}$$

$$\begin{aligned} P_3 = 15 \text{ MPa} & \left\{ \begin{aligned} h_3 &= 3310.8 \text{ kJ/kg} \\ T_3 = 500^\circ\text{C} & \left\{ \begin{aligned} s_3 &= 6.3480 \text{ kJ/kg} \cdot \text{K} \end{aligned} \right. \end{aligned} \right. \end{aligned}$$

$$\begin{aligned} P_6 = 10 \text{ kPa} & \left\{ \begin{aligned} h_6 &= h_f + x_6 h_{fg} = 191.81 + (0.90)(2392.1) = 2344.7 \text{ kJ/kg} \\ s_6 = s_5 & \left\{ \begin{aligned} s_6 &= s_f + x_6 s_{fg} = 0.6492 + (0.90)(7.4996) = 7.3988 \text{ kJ/kg} \cdot \text{K} \end{aligned} \right. \end{aligned} \right. \end{aligned}$$

$$\begin{aligned} T_5 = 500^\circ\text{C} & \left\{ \begin{aligned} P_5 &= \mathbf{2150 \text{ kPa}} \text{ (the reheat pressure)} \\ s_5 = s_6 & \left\{ \begin{aligned} h_5 &= 3466.61 \text{ kJ/kg} \end{aligned} \right. \end{aligned} \right. \end{aligned}$$

$$\begin{aligned} P_4 = 2.15 \text{ MPa} & \left\{ \begin{aligned} h_4 &= 2817.2 \text{ kJ/kg} \\ s_4 = s_3 & \end{aligned} \right. \end{aligned}$$

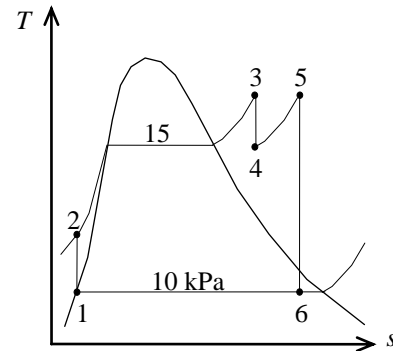

(b) The rate of heat supply is

$$\begin{aligned} \dot{Q}_{\text{in}} &= \dot{m}[(h_3 - h_2) + (h_5 - h_4)] \\ &= (12 \text{ kg/s})(3310.8 - 206.95 + 3466.61 - 2817.2) \text{ kJ/kg} \\ &= \mathbf{45,039 \text{ kW}} \end{aligned}$$

(c) The thermal efficiency is determined from

$$\dot{Q}_{\text{out}} = \dot{m}(h_6 - h_1) = (12 \text{ kg/s})(2344.7 - 191.81) \text{ kJ/kg} = 25,835 \text{ kJ/s}$$

Thus,

$$\eta_{\text{th}} = 1 - \frac{\dot{Q}_{\text{out}}}{\dot{Q}_{\text{in}}} = 1 - \frac{25,834 \text{ kJ/s}}{45,039 \text{ kJ/s}} = \mathbf{42.6\%}$$

10-36 A steam power plant that operates on a reheat Rankine cycle is considered. The condenser pressure, the net power output, and the thermal efficiency are to be determined.

Assumptions 1 Steady operating conditions exist. **2** Kinetic and potential energy changes are negligible.

Analysis (a) From the steam tables (Tables A-4, A-5, and A-6),

$$\left. \begin{array}{l} P_3 = 12.5 \text{ MPa} \\ T_3 = 550^\circ\text{C} \end{array} \right\} \begin{array}{l} h_3 = 3476.5 \text{ kJ/kg} \\ s_3 = 6.6317 \text{ kJ/kg}\cdot\text{K} \end{array}$$

$$\left. \begin{array}{l} P_4 = 2 \text{ MPa} \\ s_{4s} = s_3 \end{array} \right\} h_{4s} = 2948.1 \text{ kJ/kg}$$

$$\eta_T = \frac{h_3 - h_4}{h_3 - h_{4s}}$$

$$\begin{aligned} \rightarrow h_4 &= h_3 - \eta_T (h_3 - h_{4s}) \\ &= 3476.5 - (0.85)(3476.5 - 2948.1) \\ &= 3027.3 \text{ kJ/kg} \end{aligned}$$

$$\left. \begin{array}{l} P_5 = 2 \text{ MPa} \\ T_5 = 450^\circ\text{C} \end{array} \right\} \begin{array}{l} h_5 = 3358.2 \text{ kJ/kg} \\ s_5 = 7.2815 \text{ kJ/kg}\cdot\text{K} \end{array}$$

$$\left. \begin{array}{l} P_6 = ? \\ x_6 = 0.95 \end{array} \right\} h_6 = \quad (\text{Eq. 1})$$

$$\left. \begin{array}{l} P_6 = ? \\ s_6 = s_5 \end{array} \right\} h_{6s} = \quad (\text{Eq. 2})$$

$$\eta_T = \frac{h_5 - h_6}{h_5 - h_{6s}} \rightarrow h_6 = h_5 - \eta_T (h_5 - h_{6s}) = 3358.2 - (0.85)(3358.2 - h_{6s}) \quad (\text{Eq. 3})$$

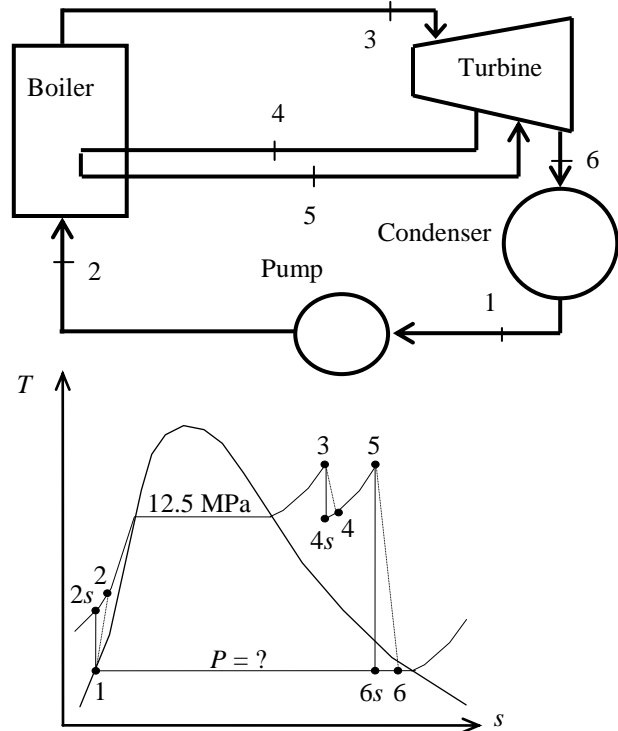

The pressure at state 6 may be determined by a trial-error approach from the steam tables or by using EES from the above three equations:

$$P_6 = \mathbf{9.73 \text{ kPa}}, \quad h_6 = 2463.3 \text{ kJ/kg},$$

(b) Then,

$$h_1 = h_f @ 9.73 \text{ kPa} = 189.57 \text{ kJ/kg}$$

$$v_1 = v_f @ 10 \text{ kPa} = 0.001010 \text{ m}^3/\text{kg}$$

$$\begin{aligned} w_{p,\text{in}} &= v_1 (P_2 - P_1) / \eta_p \\ &= (0.00101 \text{ m}^3/\text{kg})(12,500 - 9.73 \text{ kPa}) \left(\frac{1 \text{ kJ}}{1 \text{ kPa}\cdot\text{m}^3} \right) / (0.90) \\ &= 14.02 \text{ kJ/kg} \end{aligned}$$

$$h_2 = h_1 + w_{p,\text{in}} = 189.57 + 14.02 = 203.59 \text{ kJ/kg}$$

Cycle analysis:

$$q_{\text{in}} = (h_3 - h_2) + (h_5 - h_4) = 3476.5 - 203.59 + 3358.2 - 2463.3 = 3603.8 \text{ kJ/kg}$$

$$q_{\text{out}} = h_6 - h_1 = 2463.3 - 189.57 = 2273.7 \text{ kJ/kg}$$

$$\dot{W}_{\text{net}} = \dot{m}(q_{\text{in}} - q_{\text{out}}) = (7.7 \text{ kg/s})(3603.8 - 2273.7) \text{ kJ/kg} = \mathbf{10,242 \text{ kW}}$$

(c) The thermal efficiency is

$$\eta_{\text{th}} = 1 - \frac{q_{\text{out}}}{q_{\text{in}}} = 1 - \frac{2273.7 \text{ kJ/kg}}{3603.8 \text{ kJ/kg}} = 0.369 = \mathbf{36.9\%}$$

10-37 A steam power plant that operates on a reheat Rankine cycle is considered. The quality (or temperature, if superheated) of the steam at the turbine exit, the thermal efficiency of the cycle, and the mass flow rate of the steam are to be determined.

Assumptions 1 Steady operating conditions exist. 2 Kinetic and potential energy changes are negligible.

Analysis (a) From the steam tables (Tables A-4, A-5, and A-6),

$$h_1 = h_{f@10\text{ kPa}} = 191.81 \text{ kJ/kg}$$

$$v_1 = v_{f@10\text{ kPa}} = 0.001010 \text{ m}^3/\text{kg}$$

$$w_{p,\text{in}} = v_1(P_2 - P_1)/\eta_p = (0.00101 \text{ m}^3/\text{kg})(10,000 - 10 \text{ kPa}) \left(\frac{1 \text{ kJ}}{1 \text{ kPa} \cdot \text{m}^3} \right) / (0.95) = 10.62 \text{ kJ/kg}$$

$$h_2 = h_1 + w_{p,\text{in}} = 191.81 + 10.62 = 202.43 \text{ kJ/kg}$$

$$\left. \begin{array}{l} P_3 = 10 \text{ MPa} \\ T_3 = 500^\circ\text{C} \end{array} \right\} \begin{array}{l} h_3 = 3375.1 \text{ kJ/kg} \\ s_3 = 6.5995 \text{ kJ/kg} \cdot \text{K} \end{array}$$

$$\left. \begin{array}{l} P_{4s} = 1 \text{ MPa} \\ s_{4s} = s_3 \end{array} \right\} h_{4s} = 2783.8 \text{ kJ/kg}$$

$$\eta_T = \frac{h_3 - h_4}{h_3 - h_{4s}} \longrightarrow h_4 = h_3 - \eta_T(h_3 - h_{4s}) = 3375.1 - (0.80)(3375.1 - 2783.7) = 2902.0 \text{ kJ/kg}$$

$$\left. \begin{array}{l} P_5 = 1 \text{ MPa} \\ T_5 = 500^\circ\text{C} \end{array} \right\} \begin{array}{l} h_5 = 3479.1 \text{ kJ/kg} \\ s_5 = 7.7642 \text{ kJ/kg} \cdot \text{K} \end{array}$$

$$\left. \begin{array}{l} P_{6s} = 10 \text{ kPa} \\ s_{6s} = s_5 \end{array} \right\} \begin{array}{l} x_{6s} = \frac{s_{6s} - s_f}{s_{fg}} = \frac{7.7642 - 0.6492}{7.4996} = 0.9487 \text{ (at turbine exit)} \\ h_{6s} = h_f + x_{6s}h_{fg} = 191.81 + (0.9487)(2392.1) = 2461.2 \text{ kJ/kg} \end{array}$$

$$\eta_T = \frac{h_5 - h_6}{h_5 - h_{6s}} \longrightarrow h_6 = h_5 - \eta_T(h_5 - h_{6s}) = 3479.1 - (0.80)(3479.1 - 2461.2) = 2664.8 \text{ kJ/kg} > h_g \text{ (superheated vapor)}$$

From steam tables at 10 kPa we read $T_6 = 88.1^\circ\text{C}$.

$$(b) \quad w_{T,\text{out}} = (h_3 - h_4) + (h_5 - h_6) = 3375.1 - 2902.0 + 3479.1 - 2664.8 = 1287.4 \text{ kJ/kg}$$

$$q_{\text{in}} = (h_3 - h_2) + (h_5 - h_4) = 3375.1 - 202.43 + 3479.1 - 2902.0 = 3749.8 \text{ kJ/kg}$$

$$w_{\text{net}} = w_{T,\text{out}} - w_{p,\text{in}} = 1287.4 - 10.62 = 1276.8 \text{ kJ/kg}$$

Thus the thermal efficiency is

$$\eta_{\text{th}} = \frac{w_{\text{net}}}{q_{\text{in}}} = \frac{1276.8 \text{ kJ/kg}}{3749.8 \text{ kJ/kg}} = \mathbf{34.1\%}$$

(c) The mass flow rate of the steam is

$$\dot{m} = \frac{\dot{W}_{\text{net}}}{w_{\text{net}}} = \frac{80,000 \text{ kJ/s}}{1276.9 \text{ kJ/kg}} = \mathbf{62.7 \text{ kg/s}}$$

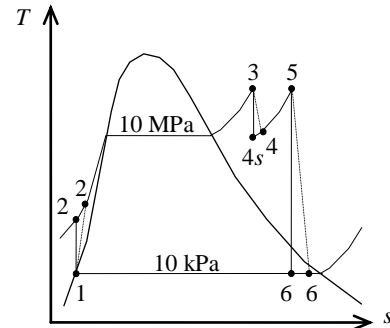

10-38 A steam power plant that operates on the ideal reheat Rankine cycle is considered. The quality (or temperature, if superheated) of the steam at the turbine exit, the thermal efficiency of the cycle, and the mass flow rate of the steam are to be determined.

Assumptions 1 Steady operating conditions exist. **2** Kinetic and potential energy changes are negligible.

Analysis (a) From the steam tables (Tables A-4, A-5, and A-6),

$$h_1 = h_{f@10\text{ kPa}} = 191.81 \text{ kJ/kg}$$

$$v_1 = v_{f@10\text{ kPa}} = 0.00101 \text{ m}^3/\text{kg}$$

$$\begin{aligned} w_{p,\text{in}} &= v_1(P_2 - P_1) \\ &= (0.00101 \text{ m}^3/\text{kg})(10,000 - 10 \text{ kPa}) \left(\frac{1 \text{ kJ}}{1 \text{ kPa} \cdot \text{m}^3} \right) \\ &= 10.09 \text{ kJ/kg} \end{aligned}$$

$$h_2 = h_1 + w_{p,\text{in}} = 191.81 + 10.09 = 201.90 \text{ kJ/kg}$$

$$\left. \begin{aligned} P_3 &= 10 \text{ MPa} \\ T_3 &= 500^\circ\text{C} \end{aligned} \right\} \begin{aligned} h_3 &= 3375.1 \text{ kJ/kg} \\ s_3 &= 6.5995 \text{ kJ/kg} \cdot \text{K} \end{aligned}$$

$$\left. \begin{aligned} P_4 &= 1 \text{ MPa} \\ s_4 &= s_3 \end{aligned} \right\} h_4 = 2783.8 \text{ kJ/kg}$$

$$\left. \begin{aligned} P_5 &= 1 \text{ MPa} \\ T_5 &= 500^\circ\text{C} \end{aligned} \right\} \begin{aligned} h_5 &= 3479.1 \text{ kJ/kg} \\ s_5 &= 7.7642 \text{ kJ/kg} \cdot \text{K} \end{aligned}$$

$$\left. \begin{aligned} P_6 &= 10 \text{ kPa} \\ s_6 &= s_5 \end{aligned} \right\} \begin{aligned} x_6 &= \frac{s_6 - s_f}{s_{fg}} = \frac{7.7642 - 0.6492}{7.4996} = \mathbf{0.9487} \text{ (at turbine exit)} \\ h_6 &= h_f + x_6 h_{fg} = 191.81 + (0.9487)(2392.1) = 2461.2 \text{ kJ/kg} \end{aligned}$$

$$(b) \quad w_{T,\text{out}} = (h_3 - h_4) + (h_5 - h_6) = 3375.1 - 2783.7 + 3479.1 - 2461.2 = 1609.3 \text{ kJ/kg}$$

$$q_{\text{in}} = (h_3 - h_2) + (h_5 - h_4) = 3375.1 - 201.90 + 3479.1 - 2783.7 = 3868.5 \text{ kJ/kg}$$

$$w_{\text{net}} = w_{T,\text{out}} - w_{p,\text{in}} = 1609.3 - 10.09 = 1599.3 \text{ kJ/kg}$$

Thus the thermal efficiency is

$$\eta_{\text{th}} = \frac{w_{\text{net}}}{q_{\text{in}}} = \frac{1599.3 \text{ kJ/kg}}{3868.5 \text{ kJ/kg}} = \mathbf{41.3\%}$$

(c) The mass flow rate of the steam is

$$\dot{m} = \frac{\dot{W}_{\text{net}}}{w_{\text{net}}} = \frac{80,000 \text{ kJ/s}}{1599.3 \text{ kJ/kg}} = \mathbf{50.0 \text{ kg/s}}$$

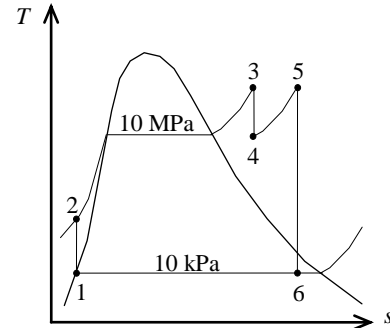

Regenerative Rankine Cycle

10-39C This is a smart idea because we waste little work potential but we save a lot from the heat input. The extracted steam has little work potential left, and most of its energy would be part of the heat rejected anyway. Therefore, by regeneration, we utilize a considerable amount of heat by sacrificing little work output.

10-40C Both cycles would have the same efficiency.

10-41C In open feedwater heaters, the two fluids actually mix, but in closed feedwater heaters there is no mixing.

10-42C Moisture content remains the same, everything else decreases.

10-43E Feedwater is heated by steam in a feedwater heater of a regenerative Rankine cycle. The ratio of the bleed steam mass flow rate to the inlet feedwater mass flow rate is to be determined.

Assumptions 1 This is a steady-flow process since there is no change with time. **2** Kinetic and potential energy changes are negligible. **3** There are no work interactions. **4** The device is adiabatic and thus heat transfer is negligible.

Properties From the steam tables (Tables A-4E through A-6E or EES),

$$h_1 \cong h_f @ 110^\circ\text{F} = 78.02 \text{ Btu/lbm}$$

$$\left. \begin{array}{l} P_2 = 40 \text{ psia} \\ T_2 = 280^\circ\text{F} \end{array} \right\} h_2 = 1176.6 \text{ Btu/lbm}$$

$$h_3 \cong h_f @ 250^\circ\text{F} = 218.63 \text{ Btu/lbm}$$

Analysis We take the mixing chamber as the system, which is a control volume since mass crosses the boundary. The mass and energy balances for this steady-flow system can be expressed in the rate form as

Mass balance:

$$\begin{aligned} \dot{m}_{\text{in}} - \dot{m}_{\text{out}} &= \Delta \dot{m}_{\text{system}} \stackrel{\neq 0 \text{ (steady)}}{=} 0 \\ \dot{m}_{\text{in}} &= \dot{m}_{\text{out}} \\ \dot{m}_1 + \dot{m}_2 &= \dot{m}_3 \end{aligned}$$

Energy balance:

$$\underbrace{\dot{E}_{\text{in}} - \dot{E}_{\text{out}}}_{\text{Rate of net energy transfer by heat, work, and mass}} = \underbrace{\Delta \dot{E}_{\text{system}}}_{\text{Rate of change in internal, kinetic, potential, etc. energies}} \stackrel{\neq 0 \text{ (steady)}}{=} 0$$

$$\dot{E}_{\text{in}} = \dot{E}_{\text{out}}$$

$$\dot{m}_1 h_1 + \dot{m}_2 h_2 = \dot{m}_3 h_3 \quad (\text{since } \dot{Q} = \dot{W} = \Delta \text{ke} \cong \Delta \text{pe} \cong 0)$$

$$\dot{m}_1 h_1 + \dot{m}_2 h_2 = (\dot{m}_1 + \dot{m}_2) h_3$$

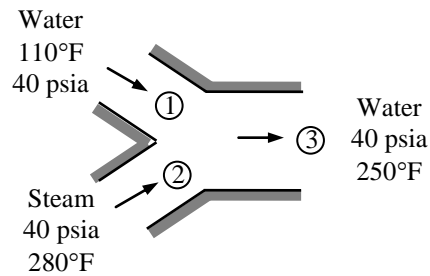

Solving for the bleed steam mass flow rate to the inlet feedwater mass flow rate, and substituting gives

$$\frac{\dot{m}_2}{\dot{m}_1} = \frac{h_1 - h_3}{h_3 - h_2} = \frac{(78.02 - 218.63) \text{ kJ/kg}}{(218.63 - 1176.6) \text{ kJ/kg}} = \mathbf{0.147}$$

10-44 In a regenerative Rankine cycle, the closed feedwater heater with a pump as shown in the figure is arranged so that the water at state 5 is mixed with the water at state 2 to form a feedwater which is a saturated liquid. The amount of bleed steam required to heat 1 kg of feedwater is to be determined.

Assumptions 1 This is a steady-flow process since there is no change with time. **2** Kinetic and potential energy changes are negligible. **3** There are no work interactions. **4** The device is adiabatic and thus heat transfer is negligible.

Properties From the steam tables (Tables A-4 through A-6),

$$\left. \begin{array}{l} P_1 = 7000 \text{ kPa} \\ T_1 = 260^\circ\text{C} \end{array} \right\} h_1 \cong h_f @ 260^\circ\text{C} = 1134.8 \text{ kJ/kg}$$

$$\left. \begin{array}{l} P_3 = 6000 \text{ kPa} \\ T_3 = 325^\circ\text{C} \end{array} \right\} h_3 = 2969.5 \text{ kJ/kg}$$

$$\left. \begin{array}{l} P_6 = 7000 \text{ kPa} \\ x_6 = 0 \end{array} \right\} h_6 = h_f @ 7000\text{kPa} = 1267.5 \text{ kJ/kg}$$

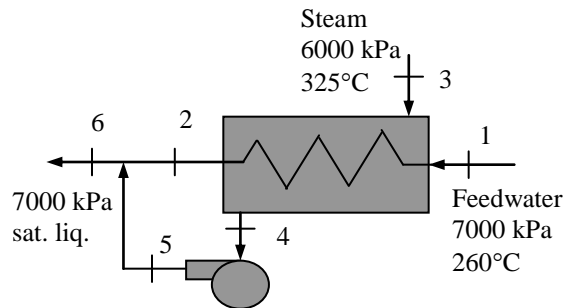

Analysis We take the entire unit as the system, which is a control volume since mass crosses the boundary. The energy balance for this steady-flow system can be expressed in the rate form as

$$\underbrace{\dot{E}_{in} - \dot{E}_{out}}_{\text{Rate of net energy transfer by heat, work, and mass}} = \underbrace{\Delta \dot{E}_{system}}_{\substack{\neq 0 \text{ (steady)} \\ \text{Rate of change in internal, kinetic, potential, etc. energies}}} = 0$$

$$\dot{E}_{in} = \dot{E}_{out}$$

$$\dot{m}_1 h_1 + \dot{m}_3 h_3 + \dot{m}_3 w_{p,in} = \dot{m}_6 h_6$$

$$\dot{m}_1 h_1 + \dot{m}_3 h_3 + \dot{m}_3 w_{p,in} = (\dot{m}_1 + \dot{m}_3) h_6$$

Solving this for \dot{m}_3 ,

$$\dot{m}_3 = \dot{m}_1 \frac{h_6 - h_1}{(h_3 - h_6) + w_{p,in}} = (1 \text{ kg/s}) \frac{1267.5 - 1134.8}{2969.5 - 1267.5 + 1.319} = \mathbf{0.0779 \text{ kg/s}}$$

where

$$\begin{aligned} w_{p,in} &= v_4 (P_5 - P_4) = v_{f @ 6000\text{kPa}} (P_5 - P_4) \\ &= (0.001319 \text{ m}^3/\text{kg})(7000 - 6000) \text{ kPa} \left(\frac{1 \text{ kPa}}{1 \text{ kPa} \cdot \text{m}^3} \right) \\ &= 1.319 \text{ kJ/kg} \end{aligned}$$

10-45 A steam power plant that operates on an ideal regenerative Rankine cycle with an open feedwater heater is considered. The net work output per kg of steam and the thermal efficiency of the cycle are to be determined.

Assumptions 1 Steady operating conditions exist. 2 Kinetic and potential energy changes are negligible.

Analysis (a) From the steam tables (Tables A-4, A-5, and A-6),

$$h_1 = h_f @ 20 \text{ kPa} = 251.42 \text{ kJ/kg}$$

$$v_1 = v_f @ 20 \text{ kPa} = 0.001017 \text{ m}^3/\text{kg}$$

$$\begin{aligned} w_{pI,in} &= v_1(P_2 - P_1) \\ &= (0.001017 \text{ m}^3/\text{kg})(400 - 20 \text{ kPa}) \left(\frac{1 \text{ kJ}}{1 \text{ kPa} \cdot \text{m}^3} \right) \\ &= 0.39 \text{ kJ/kg} \end{aligned}$$

$$h_2 = h_1 + w_{pI,in} = 251.42 + 0.39 = 251.81 \text{ kJ/kg}$$

$$\left. \begin{array}{l} P_3 = 0.4 \text{ MPa} \\ \text{sat. liquid} \end{array} \right\} \begin{array}{l} h_3 = h_f @ 0.4 \text{ MPa} = 604.66 \text{ kJ/kg} \\ v_3 = v_f @ 0.4 \text{ MPa} = 0.001084 \text{ m}^3/\text{kg} \end{array}$$

$$w_{pII,in} = v_3(P_4 - P_3) = (0.001084 \text{ m}^3/\text{kg})(6000 - 400 \text{ kPa}) \left(\frac{1 \text{ kJ}}{1 \text{ kPa} \cdot \text{m}^3} \right) = 6.07 \text{ kJ/kg}$$

$$h_4 = h_3 + w_{pII,in} = 604.66 + 6.07 = 610.73 \text{ kJ/kg}$$

$$\left. \begin{array}{l} P_5 = 6 \text{ MPa} \\ T_5 = 450^\circ\text{C} \end{array} \right\} \begin{array}{l} h_5 = 3302.9 \text{ kJ/kg} \\ s_5 = 6.7219 \text{ kJ/kg} \cdot \text{K} \end{array}$$

$$\left. \begin{array}{l} P_6 = 0.4 \text{ MPa} \\ s_6 = s_5 \end{array} \right\} \begin{array}{l} x_6 = \frac{s_6 - s_f}{s_{fg}} = \frac{6.7219 - 1.7765}{5.1191} = 0.9661 \\ h_6 = h_f + x_6 h_{fg} = 604.66 + (0.9661)(2133.4) = 2665.7 \text{ kJ/kg} \end{array}$$

$$\left. \begin{array}{l} P_7 = 20 \text{ kPa} \\ s_7 = s_5 \end{array} \right\} \begin{array}{l} x_7 = \frac{s_7 - s_f}{s_{fg}} = \frac{6.7219 - 0.8320}{7.0752} = 0.8325 \\ h_7 = h_f + x_7 h_{fg} = 251.42 + (0.8325)(2357.5) = 2214.0 \text{ kJ/kg} \end{array}$$

The fraction of steam extracted is determined from the steady-flow energy balance equation applied to the feedwater heater.

Noting that $\dot{Q} \cong \dot{W} \cong \Delta ke \cong \Delta pe \cong 0$,

$$\begin{aligned} \dot{E}_{in} - \dot{E}_{out} &= \Delta \dot{E}_{system} \stackrel{\text{0 (steady)}}{=} 0 \\ \dot{E}_{in} &= \dot{E}_{out} \\ \sum \dot{m}_i h_i &= \sum \dot{m}_e h_e \longrightarrow \dot{m}_6 h_6 + \dot{m}_2 h_2 = \dot{m}_3 h_3 \longrightarrow y h_6 + (1-y) h_2 = 1(h_3) \end{aligned}$$

where y is the fraction of steam extracted from the turbine ($= \dot{m}_6 / \dot{m}_3$). Solving for y ,

$$y = \frac{h_3 - h_2}{h_6 - h_2} = \frac{604.66 - 251.81}{2665.7 - 251.81} = 0.1462$$

Then,

$$q_{in} = h_5 - h_4 = 3302.9 - 610.73 = 2692.2 \text{ kJ/kg}$$

$$q_{out} = (1-y)(h_7 - h_1) = (1-0.1462)(2214.0 - 251.42) = 1675.7 \text{ kJ/kg}$$

and $w_{net} = q_{in} - q_{out} = 2692.2 - 1675.7 = \mathbf{1016.5 \text{ kJ/kg}}$

(b) The thermal efficiency is determined from

$$\eta_{th} = 1 - \frac{q_{out}}{q_{in}} = 1 - \frac{1675.7 \text{ kJ/kg}}{2692.2 \text{ kJ/kg}} = \mathbf{37.8\%}$$

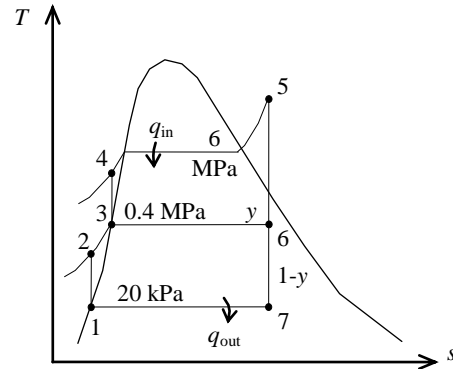

10-46 A steam power plant that operates on an ideal regenerative Rankine cycle with a closed feedwater heater is considered. The net work output per kg of steam and the thermal efficiency of the cycle are to be determined.

Assumptions 1 Steady operating conditions exist. **2** Kinetic and potential energy changes are negligible.

Analysis (a) From the steam tables (Tables A-4, A-5, and A-6),

$$h_1 = h_f @ 20 \text{ kPa} = 251.42 \text{ kJ/kg}$$

$$v_1 = v_f @ 20 \text{ kPa} = 0.001017 \text{ m}^3/\text{kg}$$

$$\begin{aligned} w_{pI,in} &= v_1(P_2 - P_1) \\ &= (0.001017 \text{ m}^3/\text{kg})(6000 - 20 \text{ kPa}) \left(\frac{1 \text{ kJ}}{1 \text{ kPa} \cdot \text{m}^3} \right) \\ &= 6.08 \text{ kJ/kg} \end{aligned}$$

$$h_2 = h_1 + w_{pI,in} = 251.42 + 6.08 = 257.50 \text{ kJ/kg}$$

$$\left. \begin{array}{l} P_3 = 0.4 \text{ MPa} \\ \text{sat. liquid} \end{array} \right\} \begin{array}{l} h_3 = h_f @ 0.4 \text{ MPa} = 604.66 \text{ kJ/kg} \\ v_3 = v_f @ 0.4 \text{ MPa} = 0.001084 \text{ m}^3/\text{kg} \end{array}$$

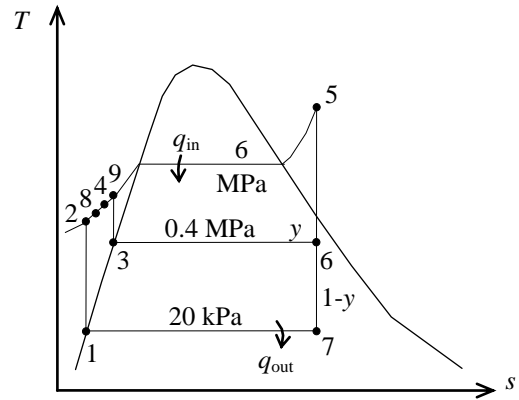

$$w_{pII,in} = v_3(P_9 - P_3) = (0.001084 \text{ m}^3/\text{kg})(6000 - 400 \text{ kPa}) \left(\frac{1 \text{ kJ}}{1 \text{ kPa} \cdot \text{m}^3} \right) = 6.07 \text{ kJ/kg}$$

$$h_9 = h_3 + w_{pII,in} = 604.66 + 6.07 = 610.73 \text{ kJ/kg}$$

$$h_8 = h_3 + v_3(P_8 - P_3) = h_9 = 610.73 \text{ kJ/kg}$$

Also, $h_4 = h_9 = h_8 = 610.73 \text{ kJ/kg}$ since the two fluid streams which are being mixed have the same enthalpy.

$$\left. \begin{array}{l} P_5 = 6 \text{ MPa} \\ T_5 = 450^\circ\text{C} \end{array} \right\} \begin{array}{l} h_5 = 3302.9 \text{ kJ/kg} \\ s_5 = 6.7219 \text{ kJ/kg} \cdot \text{K} \end{array}$$

$$\left. \begin{array}{l} P_6 = 0.4 \text{ MPa} \\ s_6 = s_5 \end{array} \right\} \begin{array}{l} x_6 = \frac{s_6 - s_f}{s_{fg}} = \frac{6.7219 - 1.7765}{5.1191} = 0.9661 \\ h_6 = h_f + x_6 h_{fg} = 604.66 + (0.9661)(2133.4) = 2665.7 \text{ kJ/kg} \end{array}$$

$$\left. \begin{array}{l} P_7 = 20 \text{ kPa} \\ s_7 = s_5 \end{array} \right\} \begin{array}{l} x_7 = \frac{s_7 - s_f}{s_{fg}} = \frac{6.7219 - 0.8320}{7.0752} = 0.8325 \\ h_7 = h_f + x_7 h_{fg} = 251.42 + (0.8325)(2357.5) = 2214.0 \text{ kJ/kg} \end{array}$$

The fraction of steam extracted is determined from the steady-flow energy balance equation applied to the feedwater heater.

Noting that $\dot{Q} \cong \dot{W} \cong \Delta \text{ke} \cong \Delta \text{pe} \cong 0$,

$$\begin{aligned} \dot{E}_{in} - \dot{E}_{out} &= \Delta \dot{E}_{system} \stackrel{\text{steady}}{\cong} 0 \\ \dot{E}_{in} &= \dot{E}_{out} \\ \sum \dot{m}_i h_i &= \sum \dot{m}_e h_e \longrightarrow \dot{m}_2(h_8 - h_2) = \dot{m}_6(h_6 - h_3) \longrightarrow (1 - y)(h_8 - h_2) = y(h_6 - h_3) \end{aligned}$$

where y is the fraction of steam extracted from the turbine ($= \dot{m}_6 / \dot{m}_5$). Solving for y ,

$$y = \frac{h_8 - h_2}{(h_6 - h_3) + (h_8 - h_2)} = \frac{610.73 - 257.50}{2665.7 - 604.66 + 610.73 - 257.50} = 0.1463$$

Then,

$$\begin{aligned} q_{in} &= h_5 - h_4 = 3302.9 - 610.73 = 2692.2 \text{ kJ/kg} \\ q_{out} &= (1 - y)(h_7 - h_1) = (1 - 0.1463)(2214.0 - 251.42) = 1675.4 \text{ kJ/kg} \end{aligned}$$

and $w_{net} = q_{in} - q_{out} = 2692.2 - 1675.4 = \mathbf{1016.8 \text{ kJ/kg}}$

(b) The thermal efficiency is determined from

$$\eta_{th} = 1 - \frac{q_{out}}{q_{in}} = 1 - \frac{1675.4 \text{ kJ/kg}}{2692.2 \text{ kJ/kg}} = \mathbf{37.8\%}$$

10-47 A steam power plant operates on an ideal regenerative Rankine cycle with two open feedwater heaters. The net power output of the power plant and the thermal efficiency of the cycle are to be determined.

Assumptions 1 Steady operating conditions exist. 2 Kinetic and potential energy changes are negligible.

Analysis

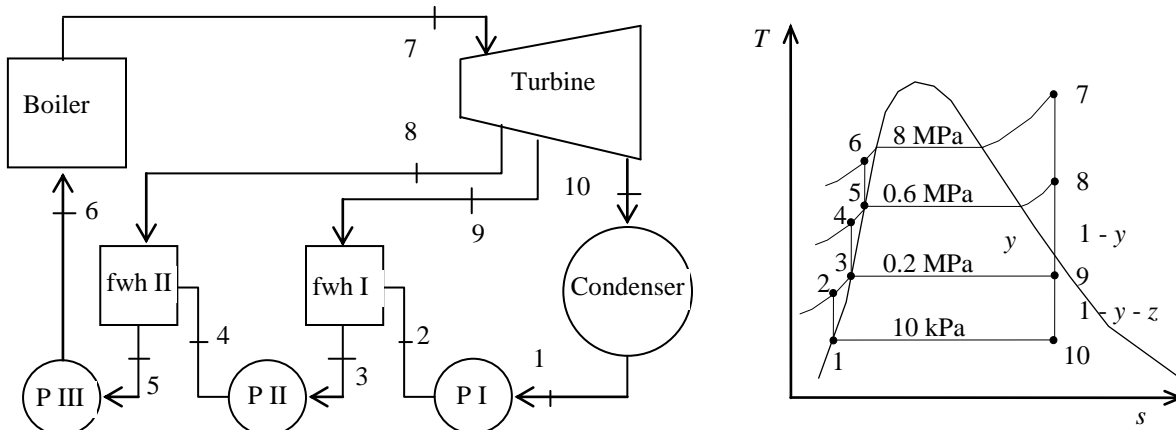

(a) From the steam tables (Tables A-4, A-5, and A-6),

$$h_1 = h_f @ 10 \text{ kPa} = 191.81 \text{ kJ/kg}$$

$$\nu_1 = \nu_f @ 10 \text{ kPa} = 0.001010 \text{ m}^3/\text{kg}$$

$$w_{pI, \text{in}} = \nu_1 (P_2 - P_1) = (0.001010 \text{ m}^3/\text{kg})(200 - 10 \text{ kPa}) \left(\frac{1 \text{ kJ}}{1 \text{ kPa} \cdot \text{m}^3} \right) = 0.192 \text{ kJ/kg}$$

$$h_2 = h_1 + w_{pI, \text{in}} = 191.81 + 0.192 = 192.00 \text{ kJ/kg}$$

$$P_3 = 0.2 \text{ MPa} \left\{ \begin{array}{l} h_3 = h_f @ 0.2 \text{ MPa} = 504.71 \text{ kJ/kg} \\ \nu_3 = \nu_f @ 0.2 \text{ MPa} = 0.001061 \text{ m}^3/\text{kg} \end{array} \right.$$

$$w_{pII, \text{in}} = \nu_3 (P_4 - P_3) = (0.001061 \text{ m}^3/\text{kg})(600 - 200 \text{ kPa}) \left(\frac{1 \text{ kJ}}{1 \text{ kPa} \cdot \text{m}^3} \right) = 0.42 \text{ kJ/kg}$$

$$h_4 = h_3 + w_{pII, \text{in}} = 504.71 + 0.42 = 505.13 \text{ kJ/kg}$$

$$P_5 = 0.6 \text{ MPa} \left\{ \begin{array}{l} h_5 = h_f @ 0.6 \text{ MPa} = 670.38 \text{ kJ/kg} \\ \nu_5 = \nu_f @ 0.6 \text{ MPa} = 0.001101 \text{ m}^3/\text{kg} \end{array} \right.$$

$$w_{pIII, \text{in}} = \nu_5 (P_6 - P_5) = (0.001101 \text{ m}^3/\text{kg})(8000 - 600 \text{ kPa}) \left(\frac{1 \text{ kJ}}{1 \text{ kPa} \cdot \text{m}^3} \right) = 8.144 \text{ kJ/kg}$$

$$h_6 = h_5 + w_{pIII, \text{in}} = 670.38 + 8.144 = 678.52 \text{ kJ/kg}$$

$$P_7 = 8 \text{ MPa} \left\{ \begin{array}{l} h_7 = 3521.8 \text{ kJ/kg} \\ T_7 = 550^\circ\text{C} \end{array} \right. \left. \begin{array}{l} s_7 = 6.8800 \text{ kJ/kg} \cdot \text{K} \end{array} \right.$$

$$P_8 = 0.6 \text{ MPa} \left\{ \begin{array}{l} h_8 = 2809.6 \text{ kJ/kg} \\ s_8 = s_7 \end{array} \right.$$

$$P_9 = 0.2 \text{ MPa} \left\{ \begin{array}{l} x_9 = \frac{s_9 - s_f}{s_{fg}} = \frac{6.8800 - 1.5302}{5.5968} = 0.9559 \\ s_9 = s_7 \end{array} \right.$$

$$h_9 = h_f + x_9 h_{fg} = 504.71 + (0.9559)(2201.6) = 2609.1 \text{ kJ/kg}$$

$$P_{10} = 10 \text{ kPa} \quad \left\{ \begin{array}{l} x_{10} = \frac{s_{10} - s_f}{s_{fg}} = \frac{6.8800 - 0.6492}{7.4996} = 0.8308 \\ s_{10} = s_7 \end{array} \right. \quad \left. \begin{array}{l} h_{10} = h_f + x_{10}h_{fg} = 191.81 + (0.8308)(2392.1) = 2179.2 \text{ kJ/kg} \end{array} \right.$$

The fraction of steam extracted is determined from the steady-flow energy balance equation applied to the feedwater heaters. Noting that $\dot{Q} \cong \dot{W} \cong \Delta ke \cong \Delta pe \cong 0$,

FWH-2:

$$\begin{aligned} \dot{E}_{\text{in}} - \dot{E}_{\text{out}} &= \Delta \dot{E}_{\text{system}} \stackrel{\phi^0(\text{steady})}{=} 0 \\ \dot{E}_{\text{in}} &= \dot{E}_{\text{out}} \\ \sum \dot{m}_i h_i &= \sum \dot{m}_e h_e \longrightarrow \dot{m}_8 h_8 + \dot{m}_4 h_4 = \dot{m}_5 h_5 \longrightarrow y h_8 + (1-y) h_4 = 1(h_5) \end{aligned}$$

where y is the fraction of steam extracted from the turbine ($= \dot{m}_8 / \dot{m}_5$). Solving for y ,

$$y = \frac{h_5 - h_4}{h_8 - h_4} = \frac{670.38 - 505.13}{2809.6 - 505.13} = 0.07171$$

FWH-1:

$$\sum \dot{m}_i h_i = \sum \dot{m}_e h_e \longrightarrow \dot{m}_9 h_9 + \dot{m}_2 h_2 = \dot{m}_3 h_3 \longrightarrow z h_9 + (1-y-z) h_2 = (1-y) h_3$$

where z is the fraction of steam extracted from the turbine ($= \dot{m}_9 / \dot{m}_5$) at the second stage. Solving for z ,

$$z = \frac{h_3 - h_2}{h_9 - h_2} (1-y) = \frac{504.71 - 192.00}{2609.1 - 192.00} (1 - 0.07171) = 0.1201$$

Then,

$$\begin{aligned} q_{\text{in}} &= h_7 - h_6 = 3521.8 - 678.52 = 2843.3 \text{ kJ/kg} \\ q_{\text{out}} &= (1-y-z)(h_{10} - h_1) = (1 - 0.07171 - 0.1201)(2179.2 - 191.81) = 1606.2 \text{ kJ/kg} \\ w_{\text{net}} &= q_{\text{in}} - q_{\text{out}} = 2843.3 - 1606.2 = 1237.2 \text{ kJ/kg} \end{aligned}$$

and

$$\dot{W}_{\text{net}} = \dot{m} w_{\text{net}} = (16 \text{ kg/s})(1237.2 \text{ kJ/kg}) = 19,795 \text{ kW} \cong \mathbf{19.8 \text{ MW}}$$

(b) The thermal efficiency is

$$\eta_{\text{th}} = 1 - \frac{q_{\text{out}}}{q_{\text{in}}} = 1 - \frac{1606.2 \text{ kJ/kg}}{2843.3 \text{ kJ/kg}} = 0.4351 = \mathbf{43.5\%}$$

10-48 An ideal regenerative Rankine cycle with a closed feedwater heater is considered. The work produced by the turbine, the work consumed by the pumps, and the heat added in the boiler are to be determined.

Assumptions 1 Steady operating conditions exist. **2** Kinetic and potential energy changes are negligible.

Analysis From the steam tables (Tables A-4, A-5, and A-6),

$$h_1 = h_f @ 20 \text{ kPa} = 251.42 \text{ kJ/kg}$$

$$\nu_1 = \nu_f @ 20 \text{ kPa} = 0.001017 \text{ m}^3/\text{kg}$$

$$w_{p,\text{in}} = \nu_1 (P_2 - P_1) \\ = (0.001017 \text{ m}^3/\text{kg})(3000 - 20) \text{ kPa} \left(\frac{1 \text{ kJ}}{1 \text{ kPa} \cdot \text{m}^3} \right) \\ = 3.03 \text{ kJ/kg}$$

$$h_2 = h_1 + w_{p,\text{in}} = 251.42 + 3.03 = 254.45 \text{ kJ/kg}$$

$$\left. \begin{array}{l} P_4 = 3000 \text{ kPa} \\ T_4 = 350^\circ\text{C} \end{array} \right\} \begin{array}{l} h_4 = 3116.1 \text{ kJ/kg} \\ s_4 = 6.7450 \text{ kJ/kg} \cdot \text{K} \end{array}$$

$$\left. \begin{array}{l} P_5 = 1000 \text{ kPa} \\ s_5 = s_4 \end{array} \right\} h_5 = 2851.9 \text{ kJ/kg}$$

$$\left. \begin{array}{l} P_6 = 20 \text{ kPa} \\ s_6 = s_4 \end{array} \right\} x_6 = \frac{s_6 - s_f}{s_{fg}} = \frac{6.7450 - 0.8320}{7.0752} = 0.8357$$

$$h_6 = h_f + x_6 h_{fg} = 251.42 + (0.8357)(2357.5) = 2221.7 \text{ kJ/kg}$$

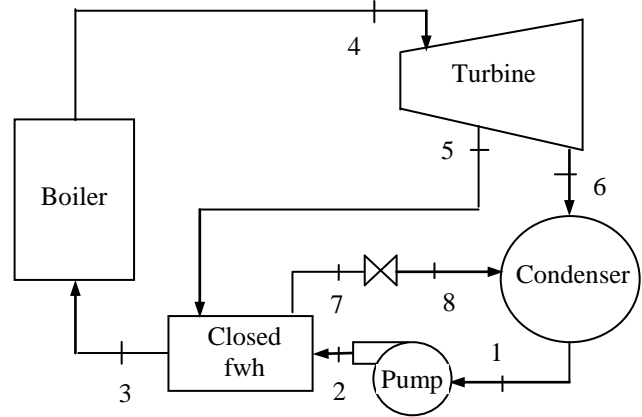

For an ideal closed feedwater heater, the feedwater is heated to the exit temperature of the extracted steam, which ideally leaves the heater as a saturated liquid at the extraction pressure.

$$\left. \begin{array}{l} P_7 = 1000 \text{ kPa} \\ x_7 = 0 \end{array} \right\} \begin{array}{l} h_7 = 762.51 \text{ kJ/kg} \\ T_7 = 179.9^\circ\text{C} \end{array}$$

$$h_8 = h_7 = 762.51 \text{ kJ/kg}$$

$$\left. \begin{array}{l} P_3 = 3000 \text{ kPa} \\ T_3 = T_7 = 209.9^\circ\text{C} \end{array} \right\} h_3 = 763.53 \text{ kJ/kg}$$

An energy balance on the heat exchanger gives the fraction of steam extracted from the turbine ($= \dot{m}_5 / \dot{m}_4$) for closed feedwater heater:

$$\sum \dot{m}_i h_i = \sum \dot{m}_e h_e \\ \dot{m}_5 h_5 + \dot{m}_2 h_2 = \dot{m}_3 h_3 + \dot{m}_7 h_7 \\ y h_5 + 1 h_2 = 1 h_3 + y h_7$$

Rearranging,

$$y = \frac{h_3 - h_2}{h_5 - h_7} = \frac{763.53 - 254.45}{2851.9 - 762.51} = 0.2437$$

Then,

$$w_{T,\text{out}} = h_4 - h_5 + (1 - y)(h_5 - h_6) = 3116.1 - 2851.9 + (1 - 0.2437)(2851.9 - 2221.7) = \mathbf{740.9 \text{ kJ/kg}}$$

$$w_{P,\text{in}} = \mathbf{3.03 \text{ kJ/kg}}$$

$$q_{\text{in}} = h_4 - h_3 = 3116.1 - 763.53 = \mathbf{2353 \text{ kJ/kg}}$$

Also, $w_{\text{net}} = w_{T,\text{out}} - w_{P,\text{in}} = 740.9 - 3.03 = 737.8 \text{ kJ/kg}$

$$\eta_{\text{th}} = \frac{w_{\text{net}}}{q_{\text{in}}} = \frac{737.8}{2353} = 0.3136$$

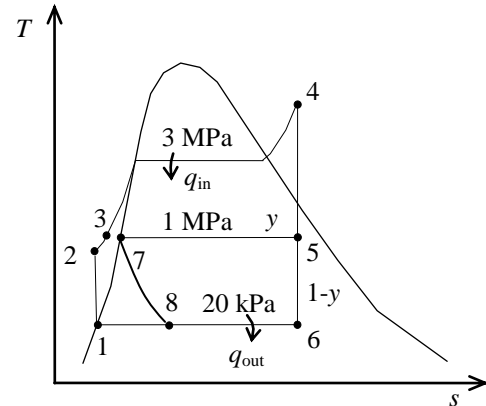



10-49 Problem 10-48 is reconsidered. The optimum bleed pressure for the open feedwater heater that maximizes the thermal efficiency of the cycle is to be determined by EES.

Analysis The EES program used to solve this problem as well as the solutions are given below.

"Given"

P[4]=3000 [kPa]
 T[4]=350 [C]
 P[5]=600 [kPa]
 P[6]=20 [kPa]

P[3]=P[4]
 P[2]=P[3]
 P[7]=P[5]
 P[1]=P[6]

"Analysis"

Fluid\$='steam_iapws'

"pump 1"

x[1]=0
 h[1]=enthalpy(Fluid\$, P=P[1], x=x[1])
 v[1]=volume(Fluid\$, P=P[1], x=x[1])
 w_p_in=v[1]*(P[2]-P[1])
 h[2]=h[1]+w_p_in

"turbine"

h[4]=enthalpy(Fluid\$, P=P[4], T=T[4])
 s[4]=entropy(Fluid\$, P=P[4], T=T[4])
 s[5]=s[4]
 h[5]=enthalpy(Fluid\$, P=P[5], s=s[5])
 T[5]=temperature(Fluid\$, P=P[5], s=s[5])
 x[5]=quality(Fluid\$, P=P[5], s=s[5])
 s[6]=s[4]
 h[6]=enthalpy(Fluid\$, P=P[6], s=s[6])
 x[6]=quality(Fluid\$, P=P[6], s=s[6])

"closed feedwater heater"

x[7]=0
 h[7]=enthalpy(Fluid\$, P=P[7], x=x[7])
 T[7]=temperature(Fluid\$, P=P[7], x=x[7])
 T[3]=T[7]
 h[3]=enthalpy(Fluid\$, P=P[3], T=T[3])
 y=(h[3]-h[2])/(h[5]-h[7]) "y=m_dot_5/m_dot_4"

"cycle"

q_in=h[4]-h[3]
 w_T_out=h[4]-h[5]+(1-y)*(h[5]-h[6])
 w_net=w_T_out-w_p_in
 Eta_th=w_net/q_in

P_6 [kPa]	η_{th}
100	0.32380
110	0.32424
120	0.32460
130	0.32490
140	0.32514
150	0.32534
160	0.32550
170	0.32563
180	0.32573
190	0.32580
200	0.32585
210	0.32588
220	0.32590
230	0.32589
240	0.32588
250	0.32585
260	0.32581
270	0.32576
280	0.32570
290	0.32563

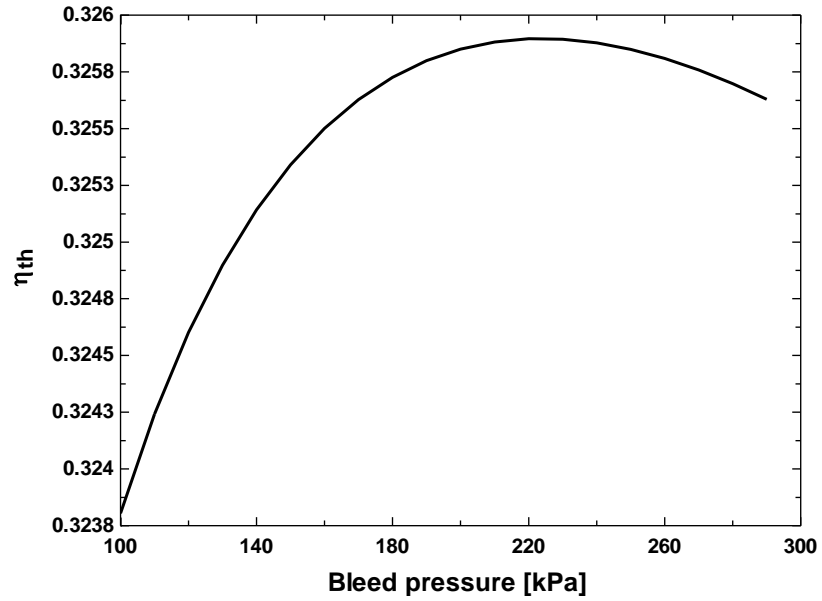

10-50 A regenerative Rankine cycle with a closed feedwater heater is considered. The thermal efficiency is to be determined.

Assumptions 1 Steady operating conditions exist. 2 Kinetic and potential energy changes are negligible.

Analysis From the steam tables (Tables A-4, A-5, and A-6 or EES),

$$h_1 = h_{f@20\text{kPa}} = 251.42 \text{ kJ/kg}$$

$$\nu_1 = \nu_{f@20\text{kPa}} = 0.001017 \text{ m}^3/\text{kg}$$

$$\begin{aligned} w_{p,\text{in}} &= \nu_1(P_2 - P_1) \\ &= (0.001017 \text{ m}^3/\text{kg})(3000 - 20)\text{kPa} \left(\frac{1 \text{ kJ}}{1 \text{ kPa} \cdot \text{m}^3} \right) \\ &= 3.03 \text{ kJ/kg} \end{aligned}$$

$$h_2 = h_1 + w_{p,\text{in}} = 251.42 + 3.03 = 254.45 \text{ kJ/kg}$$

$$\left. \begin{array}{l} P_4 = 3000 \text{ kPa} \\ T_4 = 350^\circ\text{C} \end{array} \right\} \begin{array}{l} h_4 = 3116.1 \text{ kJ/kg} \\ s_4 = 6.7450 \text{ kJ/kg} \cdot \text{K} \end{array}$$

$$\left. \begin{array}{l} P_5 = 1000 \text{ kPa} \\ s_{5s} = s_4 \end{array} \right\} h_{5s} = 2851.9 \text{ kJ/kg}$$

$$\left. \begin{array}{l} P_6 = 20 \text{ kPa} \\ s_{6s} = s_4 \end{array} \right\} \begin{array}{l} x_{6s} = \frac{s_{6s} - s_f}{s_{fg}} = \frac{6.7450 - 0.8320}{7.0752} = 0.8357 \\ h_{6s} = h_f + x_{6s}h_{fg} = 251.42 + (0.8357)(2357.5) = 2221.7 \text{ kJ/kg} \end{array}$$

$$\eta_T = \frac{h_4 - h_5}{h_4 - h_{5s}} \longrightarrow h_5 = h_4 - \eta_T(h_4 - h_{5s}) = 3116.1 - (0.90)(3116.1 - 2851.9) = 2878.3 \text{ kJ/kg}$$

$$\eta_T = \frac{h_4 - h_6}{h_4 - h_{6s}} \longrightarrow h_6 = h_4 - \eta_T(h_4 - h_{6s}) = 3116.1 - (0.90)(3116.1 - 2221.7) = 2311.1 \text{ kJ/kg}$$

For an ideal closed feedwater heater, the feedwater is heated to the exit temperature of the extracted steam, which ideally leaves the heater as a saturated liquid at the extraction pressure.

$$\left. \begin{array}{l} P_7 = 1000 \text{ kPa} \\ x_7 = 0 \end{array} \right\} \begin{array}{l} h_7 = 762.51 \text{ kJ/kg} \\ T_7 = 179.9^\circ\text{C} \end{array}$$

$$\left. \begin{array}{l} P_3 = 3000 \text{ kPa} \\ T_3 = T_7 = 209.9^\circ\text{C} \end{array} \right\} h_3 = 763.53 \text{ kJ/kg}$$

An energy balance on the heat exchanger gives the fraction of steam extracted from the turbine ($= \dot{m}_5 / \dot{m}_4$) for closed feedwater heater:

$$\begin{aligned} \sum \dot{m}_i h_i &= \sum \dot{m}_e h_e \\ \dot{m}_5 h_5 + \dot{m}_2 h_2 &= \dot{m}_3 h_3 + \dot{m}_7 h_7 \\ y h_5 + 1 h_2 &= 1 h_3 + y h_7 \end{aligned}$$

Rearranging,

$$y = \frac{h_3 - h_2}{h_5 - h_7} = \frac{763.53 - 254.45}{2878.3 - 762.51} = 0.2406$$

Then,

$$w_{T,\text{out}} = h_4 - h_5 + (1 - y)(h_5 - h_6) = 3116.1 - 2878.3 + (1 - 0.2406)(2878.3 - 2311.1) = 668.5 \text{ kJ/kg}$$

$$w_{p,\text{in}} = 3.03 \text{ kJ/kg}$$

$$q_{\text{in}} = h_4 - h_3 = 3116.1 - 763.53 = 2353 \text{ kJ/kg}$$

Also, $w_{\text{net}} = w_{T,\text{out}} - w_{p,\text{in}} = 668.5 - 3.03 = 665.5 \text{ kJ/kg}$

$$\eta_{\text{th}} = \frac{w_{\text{net}}}{q_{\text{in}}} = \frac{665.5}{2353} = 0.2829 = \mathbf{28.3\%}$$

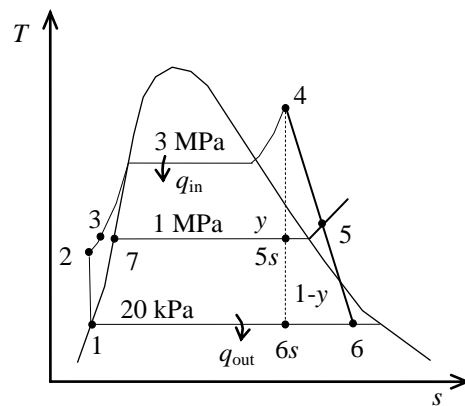
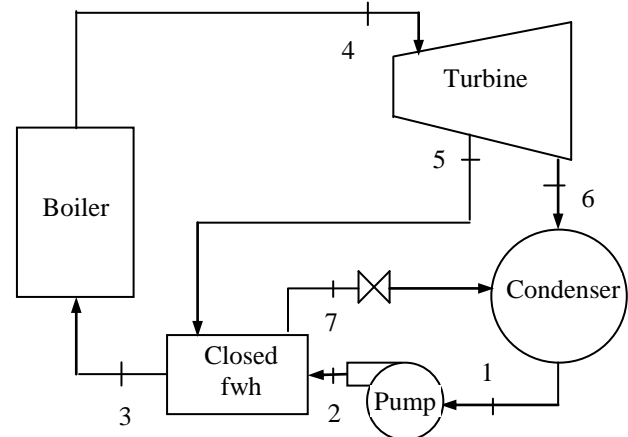

10-51 A regenerative Rankine cycle with a closed feedwater heater is considered. The thermal efficiency is to be determined.

Assumptions 1 Steady operating conditions exist. **2** Kinetic and potential energy changes are negligible.

Analysis From the steam tables (Tables A-4, A-5, and A-6 or EES),

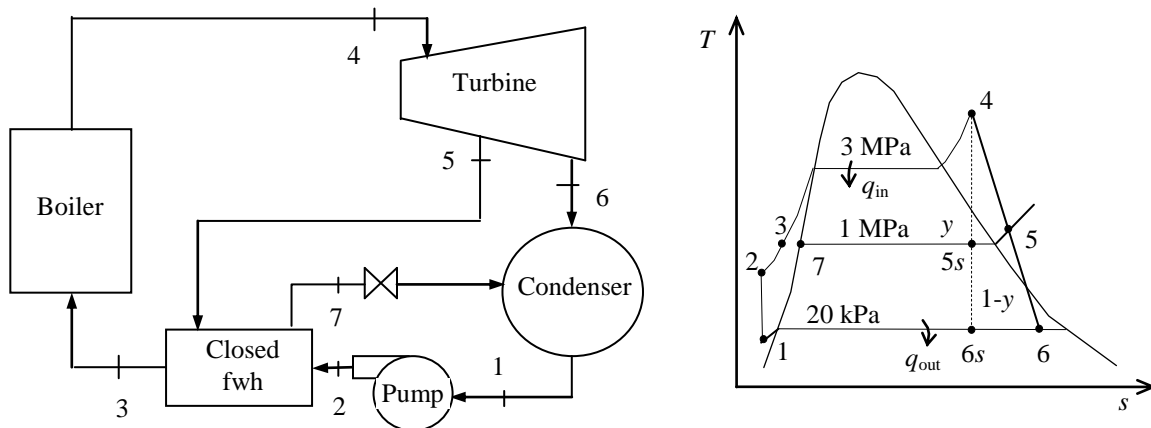

When the liquid enters the pump 10°C cooler than a saturated liquid at the condenser pressure, the enthalpies become

$$\left. \begin{aligned} P_1 &= 20 \text{ kPa} \\ T_1 &= T_{\text{sat @ } 20 \text{ kPa}} - 10 = 60.06 - 10 \cong 50^\circ\text{C} \end{aligned} \right\} \begin{aligned} h_1 &\cong h_f @ 50^\circ\text{C} = 209.34 \text{ kJ/kg} \\ \nu_1 &\cong \nu_f @ 50^\circ\text{C} = 0.001012 \text{ m}^3/\text{kg} \end{aligned}$$

$$\begin{aligned} w_{\text{p,in}} &= \nu_1 (P_2 - P_1) \\ &= (0.001012 \text{ m}^3/\text{kg})(3000 - 20) \text{ kPa} \left(\frac{1 \text{ kJ}}{1 \text{ kPa} \cdot \text{m}^3} \right) \\ &= 3.02 \text{ kJ/kg} \end{aligned}$$

$$h_2 = h_1 + w_{\text{p,in}} = 209.34 + 3.02 = 212.36 \text{ kJ/kg}$$

$$\left. \begin{aligned} P_4 &= 3000 \text{ kPa} \\ T_4 &= 350^\circ\text{C} \end{aligned} \right\} \begin{aligned} h_4 &= 3116.1 \text{ kJ/kg} \\ s_4 &= 6.7450 \text{ kJ/kg} \cdot \text{K} \end{aligned}$$

$$\left. \begin{aligned} P_5 &= 1000 \text{ kPa} \\ s_{5s} &= s_4 \end{aligned} \right\} h_{5s} = 2851.9 \text{ kJ/kg}$$

$$\left. \begin{aligned} P_6 &= 20 \text{ kPa} \\ s_{6s} &= s_4 \end{aligned} \right\} \begin{aligned} x_{6s} &= \frac{s_{6s} - s_f}{s_{fg}} = \frac{6.7450 - 0.8320}{7.0752} = 0.8357 \\ h_{6s} &= h_f + x_{6s} h_{fg} = 251.42 + (0.8357)(2357.5) = 2221.7 \text{ kJ/kg} \end{aligned}$$

$$\eta_T = \frac{h_4 - h_5}{h_4 - h_{5s}} \longrightarrow h_5 = h_4 - \eta_T (h_4 - h_{5s}) = 3116.1 - (0.90)(3116.1 - 2851.9) = 2878.3 \text{ kJ/kg}$$

$$\eta_T = \frac{h_4 - h_6}{h_4 - h_{6s}} \longrightarrow h_6 = h_4 - \eta_T (h_4 - h_{6s}) = 3116.1 - (0.90)(3116.1 - 2221.7) = 2311.1 \text{ kJ/kg}$$

For an ideal closed feedwater heater, the feedwater is heated to the exit temperature of the extracted steam, which ideally leaves the heater as a saturated liquid at the extraction pressure.

$$\left. \begin{aligned} P_7 &= 1000 \text{ kPa} \\ x_7 &= 0 \end{aligned} \right\} \begin{aligned} h_7 &= 762.51 \text{ kJ/kg} \\ T_7 &= 179.9^\circ\text{C} \end{aligned}$$

$$\left. \begin{aligned} P_3 &= 3000 \text{ kPa} \\ T_3 &= T_7 = 209.9^\circ\text{C} \end{aligned} \right\} h_3 = 763.53 \text{ kJ/kg}$$

An energy balance on the heat exchanger gives the fraction of steam extracted from the turbine ($= \dot{m}_5 / \dot{m}_4$) for closed feedwater heater:

$$\begin{aligned}\sum \dot{m}_i h_i &= \sum \dot{m}_e h_e \\ \dot{m}_5 h_5 + \dot{m}_2 h_2 &= \dot{m}_3 h_3 + \dot{m}_7 h_7 \\ y h_5 + 1 h_2 &= 1 h_3 + y h_7\end{aligned}$$

Rearranging,

$$y = \frac{h_3 - h_2}{h_5 - h_7} = \frac{763.53 - 212.36}{2878.3 - 762.51} = 0.2605$$

Then,

$$w_{T,\text{out}} = h_4 - h_5 + (1 - y)(h_5 - h_6) = 3116.1 - 2878.3 + (1 - 0.2605)(2878.3 - 2311.1) = 657.2 \text{ kJ/kg}$$

$$w_{P,\text{in}} = 3.03 \text{ kJ/kg}$$

$$q_{\text{in}} = h_4 - h_3 = 3116.1 - 763.53 = 2353 \text{ kJ/kg}$$

Also,

$$w_{\text{net}} = w_{T,\text{out}} - w_{P,\text{in}} = 657.2 - 3.03 = 654.2 \text{ kJ/kg}$$

$$\eta_{\text{th}} = \frac{w_{\text{net}}}{q_{\text{in}}} = \frac{654.2}{2353} = \mathbf{0.2781}$$



10-52 The effect of pressure drop and non-isentropic turbine on the rate of heat input is to be determined for a given power plant.

Analysis The EES program used to solve this problem as well as the solutions are given below.

"Given"

```
P[3]=3000 [kPa]
DELTAP_boiler=10 [kPa]
P[4]=P[3]-DELTAP_boiler
T[4]=350 [C]
P[5]=1000 [kPa]
P[6]=20 [kPa]
eta_T=0.90
```

```
P[2]=P[3]
P[7]=P[5]
P[1]=P[6]
```

"Analysis"

```
Fluid$='steam_iapws'
```

"(a)"

"pump 1"

```
x[1]=0
h[1]=enthalpy(Fluid$, P=P[1], x=x[1])
v[1]=volume(Fluid$, P=P[1], x=x[1])
w_p_in=v[1]*(P[2]-P[1])
h[2]=h[1]+w_p_in
```

"turbine"

```
h[4]=enthalpy(Fluid$, P=P[4], T=T[4])
s[4]=entropy(Fluid$, P=P[4], T=T[4])
s[5]=s[4]
h_s[5]=enthalpy(Fluid$, P=P[5], s=s[5])
T[5]=temperature(Fluid$, P=P[5], s=s[5])
x_s[5]=quality(Fluid$, P=P[5], s=s[5])
s[6]=s[4]
h_s[6]=enthalpy(Fluid$, P=P[6], s=s[6])
x_s[6]=quality(Fluid$, P=P[6], s=s[6])
```

```
h[5]=h[4]-eta_T*(h[4]-h_s[5])
h[6]=h[4]-eta_T*(h[4]-h_s[6])
x[5]=quality(Fluid$, P=P[5], h=h[5])
x[6]=quality(Fluid$, P=P[6], h=h[6])
```

"closed feedwater heater"

```
x[7]=0
h[7]=enthalpy(Fluid$, P=P[7], x=x[7])
T[7]=temperature(Fluid$, P=P[7], x=x[7])
T[3]=T[7]
h[3]=enthalpy(Fluid$, P=P[3], T=T[3])
y=(h[3]-h[2])/(h[5]-h[7]) "y=m_dot_5/m_dot_4"
```

"cycle"

```
q_in=h[4]-h[3]
w_T_out=h[4]-h[5]+(1-y)*(h[5]-h[6])
w_net=w_T_out-w_p_in
Eta_th=w_net/q_in
```

Solution with 10 kPa pressure drop in the boiler:

DELTAP_boiler=10 [kPa]	eta_T=0.9
Eta_th=0.2827	Fluid\$='steam_iapws'
P[3]=3000 [kPa]	P[4]=2990 [kPa]
q_in=2352.8 [kJ/kg]	w_net=665.1 [kJ/kg]
w_p_in=3.031 [m ³ -kPa/kg]	w_T_out=668.1 [kJ/kg]
y=0.2405	

Solution without any pressure drop in the boiler:

DELTAP_boiler=0 [kPa]	eta_T=1
Eta_th=0.3136	Fluid\$='steam_iapws'
P[3]=3000 [kPa]	P[4]=3000 [kPa]
q_in=2352.5 [kJ/kg]	w_net=737.8 [kJ/kg]
w_p_in=3.031 [m ³ -kPa/kg]	w_T_out=740.9 [kJ/kg]
y=0.2437	



10-53 A steam power plant operates on an ideal regenerative Rankine cycle with two feedwater heaters, one closed and one open. The mass flow rate of steam through the boiler for a net power output of 400 MW and the thermal efficiency of the cycle are to be determined.

Assumptions 1 Steady operating conditions exist. 2 Kinetic and potential energy changes are negligible.

Analysis (a) From the steam tables (Tables A-4, A-5, and A-6),

$$h_1 = h_{f@10\text{ kPa}} = 191.81 \text{ kJ/kg}$$

$$\nu_1 = \nu_{f@10\text{ kPa}} = 0.00101 \text{ m}^3/\text{kg}$$

$$\begin{aligned} w_{pI,\text{in}} &= \nu_1(P_2 - P_1) \\ &= (0.00101 \text{ m}^3/\text{kg})(600 - 10 \text{ kPa}) \left(\frac{1 \text{ kJ}}{1 \text{ kPa} \cdot \text{m}^3} \right) \\ &= 0.60 \text{ kJ/kg} \\ h_2 &= h_1 + w_{pI,\text{in}} = 191.81 + 0.60 = 192.40 \text{ kJ/kg} \end{aligned}$$

$$\begin{aligned} P_3 = 0.6 \text{ MPa} \left. \begin{array}{l} h_3 = h_{f@0.3 \text{ MPa}} = 670.38 \text{ kJ/kg} \\ \text{sat. liquid} \end{array} \right\} \nu_3 = \nu_{f@0.3 \text{ MPa}} = 0.001101 \text{ m}^3/\text{kg} \end{aligned}$$

$$\begin{aligned} w_{pII,\text{in}} &= \nu_3(P_4 - P_3) \\ &= (0.001101 \text{ m}^3/\text{kg})(10000 - 600 \text{ kPa}) \left(\frac{1 \text{ kJ}}{1 \text{ kPa} \cdot \text{m}^3} \right) \\ &= 10.35 \text{ kJ/kg} \end{aligned}$$

$$h_4 = h_3 + w_{pII,\text{in}} = 670.38 + 10.35 = 680.73 \text{ kJ/kg}$$

$$\begin{aligned} P_6 = 1.2 \text{ MPa} \left. \begin{array}{l} h_6 = h_7 = h_{f@1.2 \text{ MPa}} = 798.33 \text{ kJ/kg} \\ \text{sat. liquid} \end{array} \right\} T_6 = T_{\text{sat}@1.2 \text{ MPa}} = 188.0^\circ\text{C} \end{aligned}$$

$$T_6 = T_5, P_5 = 10 \text{ MPa} \rightarrow h_5 = 798.33 \text{ kJ/kg}$$

$$\begin{aligned} P_8 = 10 \text{ MPa} \left. \begin{array}{l} h_8 = 3625.8 \text{ kJ/kg} \\ T_8 = 600^\circ\text{C} \end{array} \right\} s_8 = 6.9045 \text{ kJ/kg} \cdot \text{K} \end{aligned}$$

$$\begin{aligned} P_9 = 1.2 \text{ MPa} \left. \begin{array}{l} h_9 = 2974.5 \text{ kJ/kg} \\ s_9 = s_8 \end{array} \right\} \end{aligned}$$

$$\begin{aligned} P_{10} = 0.6 \text{ MPa} \left. \begin{array}{l} h_{10} = 2820.9 \text{ kJ/kg} \\ s_{10} = s_8 \end{array} \right\} \end{aligned}$$

$$\begin{aligned} P_{11} = 10 \text{ kPa} \left. \begin{array}{l} x_{11} = \frac{s_{11} - s_f}{s_{fg}} = \frac{6.9045 - 0.6492}{7.4996} = 0.8341 \\ h_{11} = h_f + x_{11}h_{fg} = 191.81 + (0.8341)(2392.1) = 2187.0 \text{ kJ/kg} \end{array} \right\} \end{aligned}$$

The fraction of steam extracted is determined from the steady-flow energy balance equation applied to the feedwater heaters. Noting that $\dot{Q} \cong \dot{W} \cong \Delta ke \cong \Delta pe \cong 0$,

$$\begin{aligned} \dot{E}_{\text{in}} - \dot{E}_{\text{out}} &= \Delta \dot{E}_{\text{system}} \stackrel{\phi^0(\text{steady})}{=} 0 \\ \dot{E}_{\text{in}} &= \dot{E}_{\text{out}} \\ \sum \dot{m}_i h_i &= \sum \dot{m}_e h_e \longrightarrow \dot{m}_9(h_9 - h_6) = \dot{m}_5(h_5 - h_4) \longrightarrow y(h_9 - h_6) = (h_5 - h_4) \end{aligned}$$

where y is the fraction of steam extracted from the turbine ($= \dot{m}_{10} / \dot{m}_5$). Solving for y ,

$$y = \frac{h_5 - h_4}{h_9 - h_6} = \frac{798.33 - 680.73}{2974.5 - 798.33} = 0.05404$$

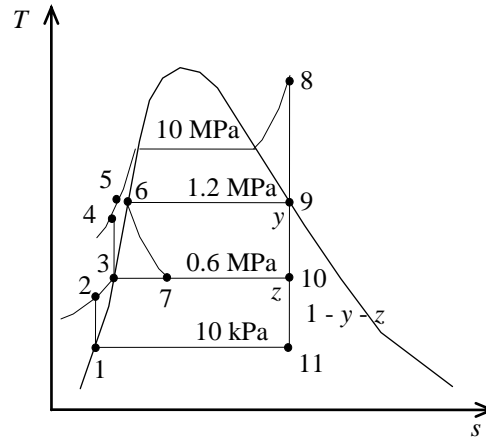
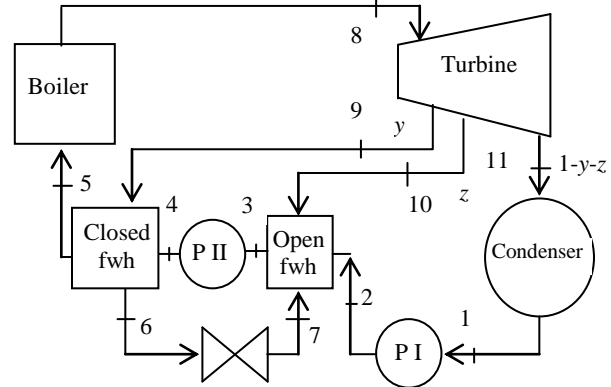

For the open FWH,

$$\dot{E}_{\text{in}} - \dot{E}_{\text{out}} = \Delta \dot{E}_{\text{system}} \stackrel{\text{steady}}{=} 0$$

$$\dot{E}_{\text{in}} = \dot{E}_{\text{out}}$$

$$\sum \dot{m}_i h_i = \sum \dot{m}_e h_e \longrightarrow \dot{m}_7 h_7 + \dot{m}_2 h_2 + \dot{m}_{10} h_{10} = \dot{m}_3 h_3 \longrightarrow y h_7 + (1 - y - z) h_2 + z h_{10} = (1) h_3$$

where z is the fraction of steam extracted from the turbine ($= \dot{m}_9 / \dot{m}_5$) at the second stage. Solving for z ,

$$z = \frac{(h_3 - h_2) - y(h_7 - h_2)}{h_{10} - h_2} = \frac{670.38 - 192.40 - (0.05404)(798.33 - 192.40)}{2820.9 - 192.40} = 0.1694$$

Then,

$$q_{\text{in}} = h_8 - h_5 = 3625.8 - 798.33 = 2827 \text{ kJ/kg}$$

$$q_{\text{out}} = (1 - y - z)(h_{11} - h_1) = (1 - 0.05404 - 0.1694)(2187.0 - 191.81) = 1549 \text{ kJ/kg}$$

$$w_{\text{net}} = q_{\text{in}} - q_{\text{out}} = 2827 - 1549 = 1278 \text{ kJ/kg}$$

and

$$\dot{m} = \frac{\dot{W}_{\text{net}}}{w_{\text{net}}} = \frac{400,000 \text{ kJ/s}}{1278 \text{ kJ/kg}} = \mathbf{313.0 \text{ kg/s}}$$

$$(b) \quad \eta_{\text{th}} = 1 - \frac{q_{\text{out}}}{q_{\text{in}}} = 1 - \frac{1549 \text{ kJ/kg}}{2827 \text{ kJ/kg}} = 0.452 = \mathbf{45.2\%}$$



10-54 Problem 10-53 is reconsidered. The effects of turbine and pump efficiencies on the mass flow rate and thermal efficiency are to be investigated. Also, the T - s diagram is to be plotted.

Analysis The problem is solved using EES, and the solution is given below.

"Input Data"

```
P[8] = 10000 [kPa]
T[8] = 600 [C]
P[9] = 1200 [kPa]
P_cfwh=600 [kPa]
P[10] = P_cfwh
P_cond=10 [kPa]
P[11] = P_cond
W_dot_net=400 [MW]*Convert(MW, kW)
Eta_turb= 100/100 "Turbine isentropic efficiency"
Eta_turb_hp = Eta_turb "Turbine isentropic efficiency for high pressure stages"
Eta_turb_ip = Eta_turb "Turbine isentropic efficiency for intermediate pressure stages"
Eta_turb_lp = Eta_turb "Turbine isentropic efficiency for low pressure stages"
Eta_pump = 100/100 "Pump isentropic efficiency"
```

"Condenser exit pump or Pump 1 analysis"

```
Fluid$='Steam_IAPWS'
P[1] = P[11]
P[2]=P[10]
h[1]=enthalpy(Fluid$,P=P[1],x=0) {Sat'd liquid}
v1=volume(Fluid$,P=P[1],x=0)
s[1]=entropy(Fluid$,P=P[1],x=0)
T[1]=temperature(Fluid$,P=P[1],x=0)
w_pump1_s=v1*(P[2]-P[1])"SSSF isentropic pump work assuming constant specific volume"
w_pump1=w_pump1_s/Eta_pump "Definition of pump efficiency"
h[1]+w_pump1= h[2] "Steady-flow conservation of energy"
s[2]=entropy(Fluid$,P=P[2],h=h[2])
T[2]=temperature(Fluid$,P=P[2],h=h[2])
```

"Open Feedwater Heater analysis"

```
z*h[10] + y*h[7] + (1-y-z)*h[2] = 1*h[3] "Steady-flow conservation of energy"
h[3]=enthalpy(Fluid$,P=P[3],x=0)
T[3]=temperature(Fluid$,P=P[3],x=0) "Condensate leaves heater as sat. liquid at P[3]"
s[3]=entropy(Fluid$,P=P[3],x=0)
```

"Boiler condensate pump or Pump 2 analysis"

```
P[5]=P[8]
P[4] = P[5]
P[3]=P[10]
v3=volume(Fluid$,P=P[3],x=0)
w_pump2_s=v3*(P[4]-P[3])"SSSF isentropic pump work assuming constant specific volume"
w_pump2=w_pump2_s/Eta_pump "Definition of pump efficiency"
h[3]+w_pump2= h[4] "Steady-flow conservation of energy"
s[4]=entropy(Fluid$,P=P[4],h=h[4])
T[4]=temperature(Fluid$,P=P[4],h=h[4])
```

"Closed Feedwater Heater analysis"

```
P[6]=P[9]
y*h[9] + 1*h[4] = 1*h[5] + y*h[6] "Steady-flow conservation of energy"
h[5]=enthalpy(Fluid$,P=P[6],x=0) "h[5] = h(T[5], P[5]) where T[5]=Tsat at P[9]"
T[5]=temperature(Fluid$,P=P[5],h=h[5]) "Condensate leaves heater as sat. liquid at P[6]"
s[5]=entropy(Fluid$,P=P[6],h=h[5])
h[6]=enthalpy(Fluid$,P=P[6],x=0)
T[6]=temperature(Fluid$,P=P[6],x=0) "Condensate leaves heater as sat. liquid at P[6]"
```

$s[6]=\text{entropy}(\text{Fluid}\$,P=P[6],x=0)$

"Trap analysis"

$P[7] = P[10]$

$y \cdot h[6] = y \cdot h[7]$ "Steady-flow conservation of energy for the trap operating as a throttle"

$T[7]=\text{temperature}(\text{Fluid}\$,P=P[7],h=h[7])$

$s[7]=\text{entropy}(\text{Fluid}\$,P=P[7],h=h[7])$

"Boiler analysis"

$q_{in} + h[5]=h[8]$ "SSSF conservation of energy for the Boiler"

$h[8]=\text{enthalpy}(\text{Fluid}\$, T=T[8], P=P[8])$

$s[8]=\text{entropy}(\text{Fluid}\$, T=T[8], P=P[8])$

"Turbine analysis"

$ss[9]=s[8]$

$hs[9]=\text{enthalpy}(\text{Fluid}\$,s=ss[9],P=P[9])$

$Ts[9]=\text{temperature}(\text{Fluid}\$,s=ss[9],P=P[9])$

$h[9]=h[8]-\text{Eta_turb_hp} \cdot (h[8]-hs[9])$ "Definition of turbine efficiency for high pressure stages"

$T[9]=\text{temperature}(\text{Fluid}\$,P=P[9],h=h[9])$

$s[9]=\text{entropy}(\text{Fluid}\$,P=P[9],h=h[9])$

$ss[10]=s[8]$

$hs[10]=\text{enthalpy}(\text{Fluid}\$,s=ss[10],P=P[10])$

$Ts[10]=\text{temperature}(\text{Fluid}\$,s=ss[10],P=P[10])$

$h[10]=h[9]-\text{Eta_turb_ip} \cdot (h[9]-hs[10])$ "Definition of turbine efficiency for Intermediate pressure stages"

$T[10]=\text{temperature}(\text{Fluid}\$,P=P[10],h=h[10])$

$s[10]=\text{entropy}(\text{Fluid}\$,P=P[10],h=h[10])$

$ss[11]=s[8]$

$hs[11]=\text{enthalpy}(\text{Fluid}\$,s=ss[11],P=P[11])$

$Ts[11]=\text{temperature}(\text{Fluid}\$,s=ss[11],P=P[11])$

$h[11]=h[10]-\text{Eta_turb_lp} \cdot (h[10]-hs[11])$ "Definition of turbine efficiency for low pressure stages"

$T[11]=\text{temperature}(\text{Fluid}\$,P=P[11],h=h[11])$

$s[11]=\text{entropy}(\text{Fluid}\$,P=P[11],h=h[11])$

$h[8] = y \cdot h[9] + z \cdot h[10] + (1-y-z) \cdot h[11] + w_{\text{turb}}$ "SSSF conservation of energy for turbine"

"Condenser analysis"

$(1-y-z) \cdot h[11]=q_{out}+(1-y-z) \cdot h[1]$ "SSSF First Law for the Condenser"

"Cycle Statistics"

$w_{\text{net}}=w_{\text{turb}} - ((1-y-z) \cdot w_{\text{pump1}} + w_{\text{pump2}})$

$\text{Eta}_{\text{th}}=w_{\text{net}}/q_{in}$

$W_{\text{dot_net}} = m_{\text{dot}} \cdot w_{\text{net}}$

η_{turb}	η_{th}	m [kg/s]
0.7	0.3834	369
0.75	0.397	356.3
0.8	0.4096	345.4
0.85	0.4212	335.8
0.9	0.4321	327.4
0.95	0.4423	319.8
1	0.452	313

η_{pump}	η_{th}	m [kg/s]
0.7	0.4509	313.8
0.75	0.4511	313.6
0.8	0.4513	313.4
0.85	0.4515	313.3
0.9	0.4517	313.2
0.95	0.4519	313.1
1	0.452	313

P_{cfwh} [kPa]	y	z
100	0.1702	0.05289
200	0.1301	0.09634
300	0.1041	0.1226
400	0.08421	0.1418
500	0.06794	0.1569
600	0.05404	0.1694
700	0.04182	0.1801
800	0.03088	0.1895
900	0.02094	0.1979
1000	0.01179	0.2054

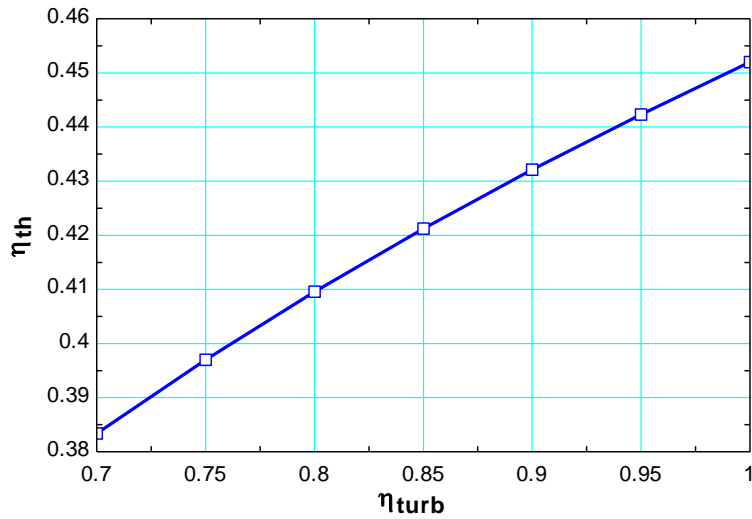
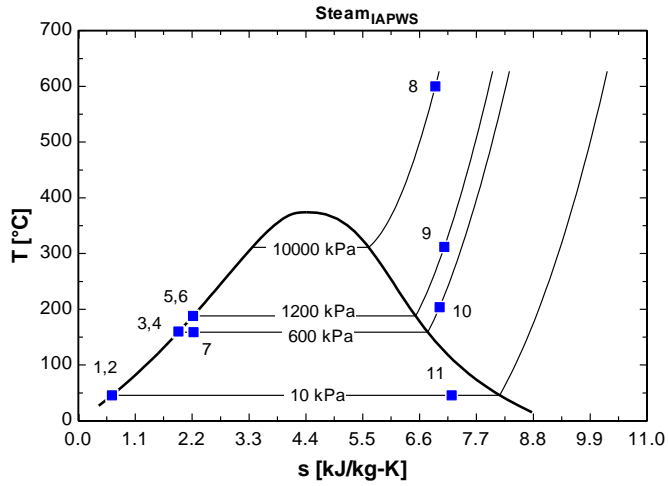

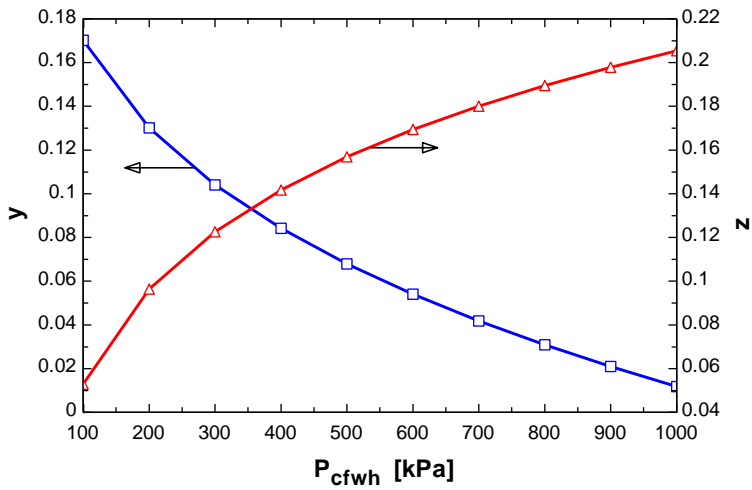
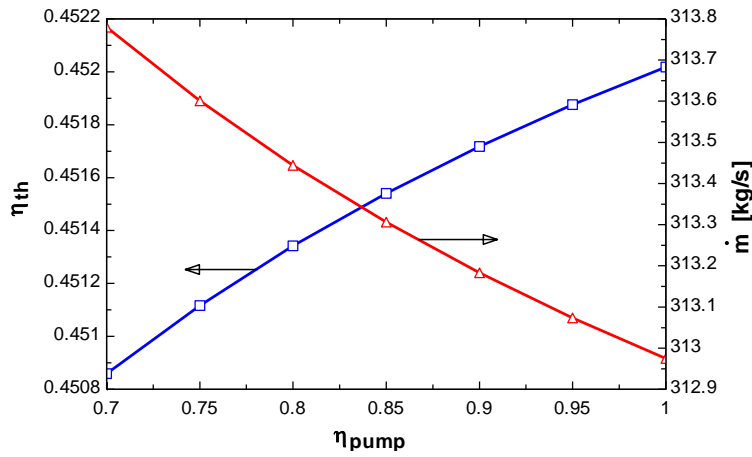
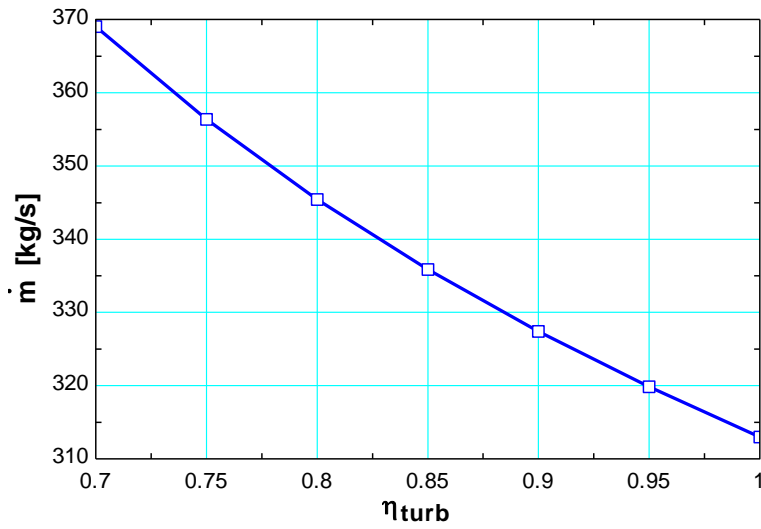

10-55 A steam power plant operates on an ideal reheat-regenerative Rankine cycle with an open feedwater heater. The mass flow rate of steam through the boiler and the thermal efficiency of the cycle are to be determined.

Assumptions 1 Steady operating conditions exist. 2 Kinetic and potential energy changes are negligible.

Analysis (a) From the steam tables (Tables A-4, A-5, and A-6),

$$h_1 = h_f @ 10 \text{ kPa} = 191.81 \text{ kJ/kg}$$

$$v_1 = v_f @ 10 \text{ kPa} = 0.00101 \text{ m}^3/\text{kg}$$

$$w_{pI, \text{in}} = v_1(P_2 - P_1) = (0.00101 \text{ m}^3/\text{kg})(800 - 10 \text{ kPa}) \left(\frac{1 \text{ kJ}}{1 \text{ kPa} \cdot \text{m}^3} \right)$$

$$= 0.80 \text{ kJ/kg}$$

$$h_2 = h_1 + w_{pI, \text{in}} = 191.81 + 0.80 = 192.61 \text{ kJ/kg}$$

$$P_3 = 0.8 \text{ MPa} \left\{ \begin{array}{l} h_3 = h_f @ 0.8 \text{ MPa} = 720.87 \text{ kJ/kg} \\ \text{sat. liquid} \left\{ \begin{array}{l} v_3 = v_f @ 0.8 \text{ MPa} = 0.001115 \text{ m}^3/\text{kg} \end{array} \right. \end{array} \right.$$

$$w_{pII, \text{in}} = v_3(P_4 - P_3) = (0.001115 \text{ m}^3/\text{kg})(10,000 - 800 \text{ kPa}) \left(\frac{1 \text{ kJ}}{1 \text{ kPa} \cdot \text{m}^3} \right)$$

$$= 10.26 \text{ kJ/kg}$$

$$h_4 = h_3 + w_{pII, \text{in}} = 720.87 + 10.26 = 731.12 \text{ kJ/kg}$$

$$P_5 = 10 \text{ MPa} \left\{ \begin{array}{l} h_5 = 3502.0 \text{ kJ/kg} \\ T_5 = 550^\circ\text{C} \left\{ \begin{array}{l} s_5 = 6.7585 \text{ kJ/kg} \cdot \text{K} \end{array} \right. \end{array} \right.$$

$$P_6 = 0.8 \text{ MPa} \left\{ \begin{array}{l} h_6 = 2812.1 \text{ kJ/kg} \\ s_6 = s_5 \end{array} \right.$$

$$P_7 = 0.8 \text{ MPa} \left\{ \begin{array}{l} h_7 = 3481.3 \text{ kJ/kg} \\ T_7 = 500^\circ\text{C} \left\{ \begin{array}{l} s_7 = 7.8692 \text{ kJ/kg} \cdot \text{K} \end{array} \right. \end{array} \right.$$

$$P_8 = 10 \text{ kPa} \left\{ \begin{array}{l} x_8 = \frac{s_8 - s_f}{s_{fg}} = \frac{7.8692 - 0.6492}{7.4996} = 0.9627 \\ s_8 = s_7 \left\{ \begin{array}{l} h_8 = h_f + x_8 h_{fg} = 191.81 + (0.9627)(2392.1) = 2494.7 \text{ kJ/kg} \end{array} \right. \end{array} \right.$$

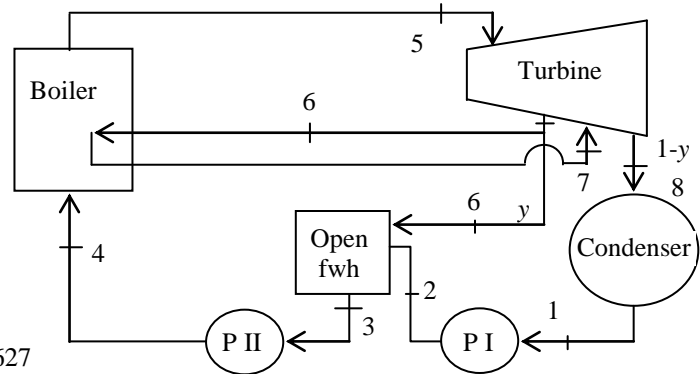
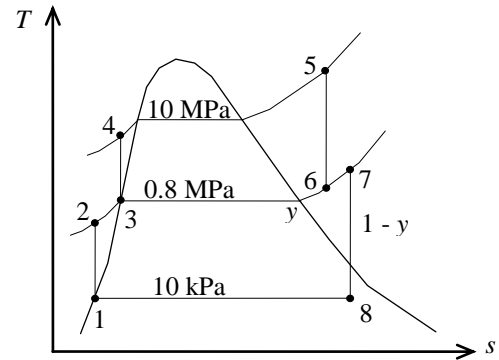

The fraction of steam extracted is determined from the steady-flow energy balance equation applied to the feedwater heaters. Noting that $\dot{Q} \cong \dot{W} \cong \Delta \text{ke} \cong \Delta \text{pe} \cong 0$,

$$\dot{E}_{\text{in}} - \dot{E}_{\text{out}} = \Delta \dot{E}_{\text{system}} \stackrel{\phi^0(\text{steady})}{=} 0 \rightarrow \dot{E}_{\text{in}} = \dot{E}_{\text{out}}$$

$$\sum \dot{m}_i h_i = \sum \dot{m}_e h_e \longrightarrow \dot{m}_6 h_6 + \dot{m}_2 h_2 = \dot{m}_3 h_3 \longrightarrow y h_6 + (1 - y) h_2 = 1(h_3)$$

where y is the fraction of steam extracted from the turbine ($= \dot{m}_6 / \dot{m}_3$). Solving for y ,

$$y = \frac{h_3 - h_2}{h_6 - h_2} = \frac{720.87 - 192.61}{2812.1 - 192.61} = 0.2017$$

$$\text{Then, } q_{\text{in}} = (h_5 - h_4) + (1 - y)(h_7 - h_6) = (3502.0 - 731.12) + (1 - 0.2017)(3481.3 - 2812.1) = 3305.1 \text{ kJ/kg}$$

$$q_{\text{out}} = (1 - y)(h_8 - h_1) = (1 - 0.2017)(2494.7 - 191.81) = 1838.5 \text{ kJ/kg}$$

$$w_{\text{net}} = q_{\text{in}} - q_{\text{out}} = 3305.1 - 1838.5 = 1466.6 \text{ kJ/kg}$$

$$\text{and } \dot{m} = \frac{\dot{W}_{\text{net}}}{w_{\text{net}}} = \frac{80,000 \text{ kJ/s}}{1466.1 \text{ kJ/kg}} = \mathbf{54.5 \text{ kg/s}}$$

$$(b) \quad \eta_{\text{th}} = \frac{w_{\text{net}}}{q_{\text{in}}} = \frac{1466.1 \text{ kJ/kg}}{3305.1 \text{ kJ/kg}} = \mathbf{44.4\%}$$

10-56 A steam power plant operates on an ideal reheat-regenerative Rankine cycle with a closed feedwater heater. The mass flow rate of steam through the boiler and the thermal efficiency of the cycle are to be determined.

Assumptions 1 Steady operating conditions exist. 2 Kinetic and potential energy changes are negligible.

Analysis

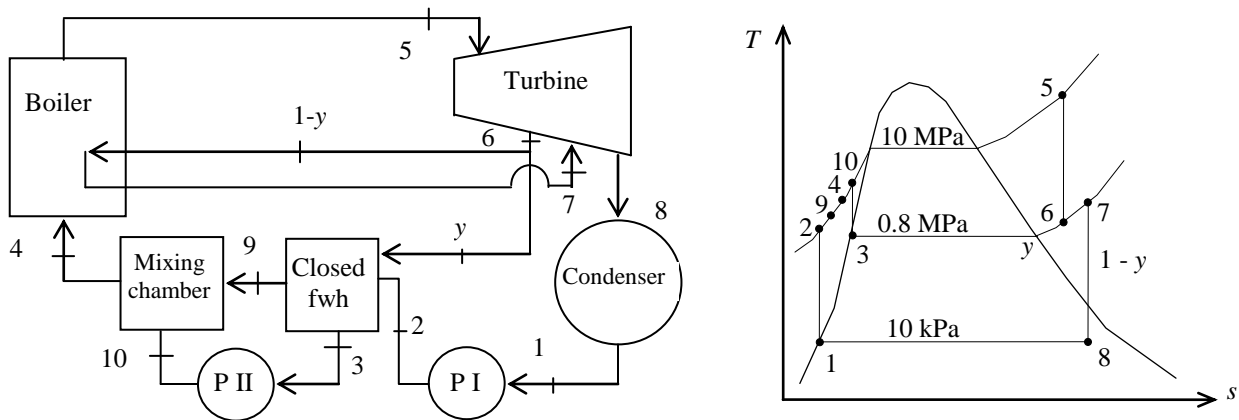

(a) From the steam tables (Tables A-4, A-5, and A-6),

$$h_1 = h_{f@10\text{kPa}} = 191.81 \text{ kJ/kg}$$

$$v_1 = v_{f@10\text{kPa}} = 0.00101 \text{ m}^3/\text{kg}$$

$$w_{pI,\text{in}} = v_1(P_2 - P_1) = (0.00101 \text{ m}^3/\text{kg})(10,000 - 10 \text{ kPa}) \left(\frac{1 \text{ kJ}}{1 \text{ kPa} \cdot \text{m}^3} \right) = 10.09 \text{ kJ/kg}$$

$$h_2 = h_1 + w_{pI,\text{in}} = 191.81 + 10.09 = 201.90 \text{ kJ/kg}$$

$$\left. \begin{array}{l} P_3 = 0.8 \text{ MPa} \\ \text{sat. liquid} \end{array} \right\} \begin{array}{l} h_3 = h_{f@0.8 \text{ MPa}} = 720.87 \text{ kJ/kg} \\ v_3 = v_{f@0.8 \text{ MPa}} = 0.001115 \text{ m}^3/\text{kg} \end{array}$$

$$w_{pII,\text{in}} = v_3(P_4 - P_3) = (0.001115 \text{ m}^3/\text{kg})(10,000 - 800 \text{ kPa}) \left(\frac{1 \text{ kJ}}{1 \text{ kPa} \cdot \text{m}^3} \right) = 10.26 \text{ kJ/kg}$$

$$h_4 = h_3 + w_{pII,\text{in}} = 720.87 + 10.26 = 731.13 \text{ kJ/kg}$$

Also, $h_4 = h_9 = h_{10} = 731.12 \text{ kJ/kg}$ since the two fluid streams that are being mixed have the same enthalpy.

$$\left. \begin{array}{l} P_5 = 10 \text{ MPa} \\ T_5 = 550^\circ\text{C} \end{array} \right\} \begin{array}{l} h_5 = 3502.0 \text{ kJ/kg} \\ s_5 = 6.7585 \text{ kJ/kg} \cdot \text{K} \end{array}$$

$$\left. \begin{array}{l} P_6 = 0.8 \text{ MPa} \\ s_6 = s_5 \end{array} \right\} h_6 = 2812.7 \text{ kJ/kg}$$

$$\left. \begin{array}{l} P_7 = 0.8 \text{ MPa} \\ T_7 = 500^\circ\text{C} \end{array} \right\} \begin{array}{l} h_7 = 3481.3 \text{ kJ/kg} \\ s_7 = 7.8692 \text{ kJ/kg} \cdot \text{K} \end{array}$$

$$\left. \begin{array}{l} P_8 = 10 \text{ kPa} \\ s_8 = s_7 \end{array} \right\} x_8 = \frac{s_8 - s_f}{s_{fg}} = \frac{7.8692 - 0.6492}{7.4996} = 0.9627$$

$$h_8 = h_f + x_8 h_{fg} = 191.81 + (0.9627)(2392.1) = 2494.7 \text{ kJ/kg}$$

The fraction of steam extracted is determined from the steady-flow energy balance equation applied to the feedwater heaters. Noting that $\dot{Q} \cong \dot{W} \cong \Delta ke \cong \Delta pe \cong 0$,

$$\dot{E}_{\text{in}} - \dot{E}_{\text{out}} = \Delta \dot{E}_{\text{system}} \stackrel{\text{steady}}{\neq} 0$$

$$\dot{E}_{\text{in}} = \dot{E}_{\text{out}}$$

$$\sum \dot{m}_i h_i = \sum \dot{m}_e h_e \longrightarrow \dot{m}_2 (h_9 - h_2) = \dot{m}_3 (h_6 - h_3) \longrightarrow (1 - y)(h_9 - h_2) = y(h_6 - h_3)$$

where y is the fraction of steam extracted from the turbine ($= \dot{m}_3 / \dot{m}_4$). Solving for y ,

$$y = \frac{h_9 - h_2}{(h_6 - h_3) + (h_9 - h_2)} = \frac{731.13 - 201.90}{2812.7 - 720.87 + 731.13 - 201.90} = 0.2019$$

Then,

$$q_{\text{in}} = (h_5 - h_4) + (1 - y)(h_7 - h_6) = (3502.0 - 731.13) + (1 - 0.2019)(3481.3 - 2812.7) = 3304.5 \text{ kJ/kg}$$

$$q_{\text{out}} = (1 - y)(h_8 - h_1) = (1 - 0.2019)(2494.7 - 191.81) = 1837.9 \text{ kJ/kg}$$

$$w_{\text{net}} = q_{\text{in}} - q_{\text{out}} = 3304.5 - 1837.8 = 1466.6 \text{ kJ/kg}$$

and

$$\dot{m} = \frac{\dot{W}_{\text{net}}}{w_{\text{net}}} = \frac{80,000 \text{ kJ/s}}{1467.1 \text{ kJ/kg}} = \mathbf{54.5 \text{ kg/s}}$$

$$(b) \quad \eta_{\text{th}} = 1 - \frac{q_{\text{out}}}{q_{\text{in}}} = 1 - \frac{1837.8 \text{ kJ/kg}}{3304.5 \text{ kJ/kg}} = \mathbf{44.4\%}$$

10-57 A Rankine steam cycle modified with two closed feedwater heaters is considered. The T - s diagram for the ideal cycle is to be sketched. The fraction of mass extracted for the closed feedwater heater z and the cooling water flow rate are to be determined. Also, the net power output and the thermal efficiency of the plant are to be determined.

Assumptions 1 Steady operating conditions exist. **2** Kinetic and potential energy changes are negligible.

Analysis (b) Using the data from the problem statement, the enthalpies at various states are

$$h_1 = h_f @ 20 \text{ kPa} = 251 \text{ kJ/kg}$$

$$\nu_1 = \nu_f @ 20 \text{ kPa} = 0.00102 \text{ m}^3/\text{kg}$$

$$\begin{aligned} w_{p,\text{in}} &= \nu_1 (P_2 - P_1) \\ &= (0.00102 \text{ m}^3/\text{kg})(5000 - 20 \text{ kPa}) \left(\frac{1 \text{ kJ}}{1 \text{ kPa} \cdot \text{m}^3} \right) \\ &= 5.1 \text{ kJ/kg} \end{aligned}$$

$$h_2 = h_1 + w_{p,\text{in}} = 251 + 5.1 = 256.1 \text{ kJ/kg}$$

Also,

$$h_3 = h_{11} = h_f @ 245 \text{ kPa} = 533 \text{ kJ/kg}$$

$$h_{12} = h_{11} \quad (\text{throttle valve operation})$$

$$h_4 = h_9 = h_f @ 1400 \text{ kPa} = 830 \text{ kJ/kg}$$

$$h_{10} = h_9 \quad (\text{throttle valve operation})$$

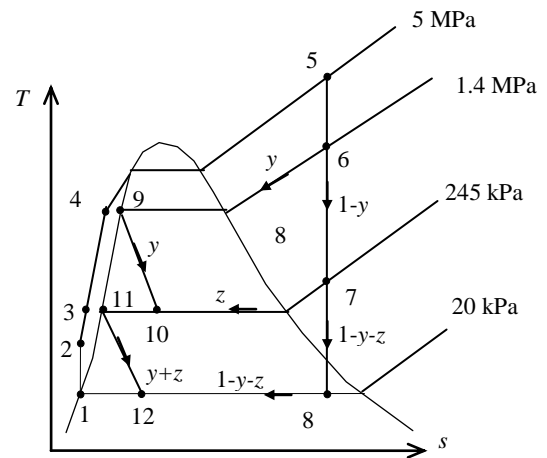

An energy balance on the closed feedwater heater gives

$$1h_2 + zh_7 + yh_{10} = 1h_3 + (y+z)h_{11}$$

where z is the fraction of steam extracted from the low-pressure turbine. Solving for z ,

$$z = \frac{(h_3 - h_2) + y(h_{11} - h_{10})}{h_7 - h_{11}} = \frac{(533 - 256.1) + (0.1446)(533 - 830)}{2918 - 533} = \mathbf{0.09810}$$

(c) An energy balance on the condenser gives

$$\dot{m}_8 h_8 + \dot{m}_w h_{w1} + \dot{m}_{12} h_{12} = \dot{m}_1 h_1 + \dot{m}_w h_{w2}$$

$$\dot{m}_w (h_{w2} - h_{w1}) = \dot{m}_8 h_8 + \dot{m}_{12} h_{12} - \dot{m}_1 h_1$$

Solving for the mass flow rate of cooling water, and substituting with correct units,

$$\begin{aligned} \dot{m}_w &= \frac{\dot{m}_5 [(1-y-z)h_8 + (y+z)h_{12} - 1h_1]}{c_{pw} \Delta T_w} \\ &= \frac{(75) [(1 - 0.1446 - 0.09810)(2477) + (0.1446 + 0.09810)(533) - 1(251)]}{(4.18)(10)} \\ &= \mathbf{3147 \text{ kg/s}} \end{aligned}$$

(d) The work output from the turbines is

$$\begin{aligned} w_{T,\text{out}} &= h_5 - yh_6 - zh_7 - (1-y-z)h_8 \\ &= 3900 - (0.1446)(3406) - (0.09810)(2918) - (1 - 0.1446 - 0.09810)(2477) \\ &= 1245.4 \text{ kJ/kg} \end{aligned}$$

The net work output from the cycle is

$$\begin{aligned} w_{\text{net}} &= w_{T,\text{out}} - w_{P,\text{in}} \\ &= 1245.4 - 5.1 = 1240.3 \text{ kJ/kg} \end{aligned}$$

The net power output is

$$\dot{W}_{\text{net}} = \dot{m} w_{\text{net}} = (75 \text{ kg/s})(1240.3 \text{ kJ/kg}) = 93,024 \text{ kW} = \mathbf{93.0 \text{ MW}}$$

The rate of heat input in the boiler is

$$\dot{Q}_{\text{in}} = \dot{m}(h_5 - h_4) = (75 \text{ kg/s})(3900 - 830) \text{ kJ/kg} = 230,250 \text{ kW}$$

The thermal efficiency is then

$$\eta_{\text{th}} = \frac{\dot{W}_{\text{net}}}{\dot{Q}_{\text{in}}} = \frac{93,024 \text{ kW}}{230,250 \text{ kW}} = 0.404 = \mathbf{40.4\%}$$

Second-Law Analysis of Vapor Power Cycles

10-58 The exergy destructions associated with each of the processes of the Rankine cycle described in Prob. 10-12 are to be determined for the specified source and sink temperatures.

Assumptions **1** Steady operating conditions exist. **2** Kinetic and potential energy changes are negligible.

Analysis From Problem 10-12,

$$s_1 = s_2 = s_f @ 50 \text{ kPa} = 1.0912 \text{ kJ/kg} \cdot \text{K}$$

$$s_3 = s_4 = 6.5412 \text{ kJ/kg} \cdot \text{K}$$

$$q_{in} = 2650.72 \text{ kJ/kg}$$

$$q_{out} = 1931.8 \text{ kJ/kg}$$

Processes 1-2 and 3-4 are isentropic. Thus, $i_{12} = 0$ and $i_{34} = 0$. Also,

$$x_{\text{destroyed}23} = T_0 \left(s_3 - s_2 + \frac{q_{R,23}}{T_R} \right) = (290 \text{ K}) \left(6.5412 - 1.0912 + \frac{-2650.8 \text{ kJ/kg}}{1500 \text{ K}} \right) = \mathbf{1068 \text{ kJ/kg}}$$

$$x_{\text{destroyed}41} = T_0 \left(s_1 - s_4 + \frac{q_{R,41}}{T_R} \right) = (290 \text{ K}) \left(1.0912 - 6.5412 + \frac{1931.8 \text{ kJ/kg}}{290 \text{ K}} \right) = \mathbf{351.3 \text{ kJ/kg}}$$

10-59 The exergy destructions associated with each of the processes of the Rankine cycle described in Prob. 10-16 are to be determined for the specified source and sink temperatures.

Assumptions **1** Steady operating conditions exist. **2** Kinetic and potential energy changes are negligible.

Analysis From Problem 10-16,

$$s_1 = s_2 = s_f @ 10 \text{ kPa} = 0.6492 \text{ kJ/kg} \cdot \text{K}$$

$$s_3 = s_4 = 6.5995 \text{ kJ/kg} \cdot \text{K}$$

$$q_{in} = 3173.2 \text{ kJ/kg}$$

$$q_{out} = 1897.9 \text{ kJ/kg}$$

Processes 1-2 and 3-4 are isentropic. Thus, $i_{12} = 0$ and $i_{34} = 0$. Also,

$$x_{\text{destroyed}23} = T_0 \left(s_3 - s_2 + \frac{q_{R,23}}{T_R} \right) = (290 \text{ K}) \left(6.5995 - 0.6492 + \frac{-3173.2 \text{ kJ/kg}}{1500 \text{ K}} \right) = \mathbf{1112.1 \text{ kJ/kg}}$$

$$x_{\text{destroyed}41} = T_0 \left(s_1 - s_4 + \frac{q_{R,41}}{T_R} \right) = (290 \text{ K}) \left(0.6492 - 6.5995 + \frac{1897.9 \text{ kJ/kg}}{290 \text{ K}} \right) = \mathbf{172.3 \text{ kJ/kg}}$$

10-60 The exergy destructions associated with each of the processes of the reheat Rankine cycle described in Prob. 10-31 are to be determined for the specified source and sink temperatures.

Assumptions 1 Steady operating conditions exist. 2 Kinetic and potential energy changes are negligible.

Analysis From Problem 10-31,

$$s_1 = s_2 = s_{f@20\text{kPa}} = 0.8320 \text{ kJ/kg} \cdot \text{K}$$

$$s_3 = s_4 = 6.5432 \text{ kJ/kg} \cdot \text{K}$$

$$s_5 = s_6 = 7.1292 \text{ kJ/kg} \cdot \text{K}$$

$$q_{23,\text{in}} = 3178.3 - 257.50 = 2920.8 \text{ kJ/kg}$$

$$q_{45,\text{in}} = 3248.4 - 2901.0 = 347.3 \text{ kJ/kg}$$

$$q_{\text{out}} = h_6 - h_1 = 2349.7 - 251.42 = 2098.3 \text{ kJ/kg}$$

Processes 1-2, 3-4, and 5-6 are isentropic. Thus, $i_{12} = i_{34} = i_{56} = 0$. Also,

$$x_{\text{destroyed}23} = T_0 \left(s_3 - s_2 + \frac{q_{R,23}}{T_R} \right) = (295 \text{ K}) \left(6.5432 - 0.8320 + \frac{-2920.8 \text{ kJ/kg}}{1500 \text{ K}} \right) = \mathbf{1110 \text{ kJ/kg}}$$

$$x_{\text{destroyed}45} = T_0 \left(s_5 - s_4 + \frac{q_{R,45}}{T_R} \right) = (295 \text{ K}) \left(7.1292 - 6.5432 + \frac{-347.3 \text{ kJ/kg}}{1500 \text{ K}} \right) = \mathbf{104.6 \text{ kJ/kg}}$$

$$x_{\text{destroyed}61} = T_0 \left(s_1 - s_6 + \frac{q_{R,61}}{T_R} \right) = (295 \text{ K}) \left(0.8320 - 7.1292 + \frac{2098.3 \text{ kJ/kg}}{295 \text{ K}} \right) = \mathbf{240.6 \text{ kJ/kg}}$$



10-61 Problem 10-60 is reconsidered. The problem is to be solved by the diagram window data entry feature of EES by including the effects of the turbine and pump efficiencies. Also, the T - s diagram is to be plotted.

Analysis The problem is solved using EES, and the solution is given below.

```

function x6$(x6) "this function returns a string to indicate the state of steam at point 6"
    x6$=""
    if (x6>1) then x6$='(superheated)'
    if (x6<0) then x6$='(subcooled)'
end
"Input Data - from diagram window"
{P[6] = 20 [kPa]
P[3] = 6000 [kPa]
T[3] = 400 [C]
P[4] = 2000 [kPa]
T[5] = 400 [C]
Eta_t = 100/100 "Turbine isentropic efficiency"
Eta_p = 100/100 "Pump isentropic efficiency"}
"Data for the irreversibility calculations:"
T_o = 295 [K]
T_R_L = 295 [K]
T_R_H = 1500 [K]
"Pump analysis"
Fluid$='Steam_IAPWS'
P[1] = P[6]
P[2]=P[3]
x[1]=0 "Sat'd liquid"
h[1]=enthalpy(Fluid$,P=P[1],x=x[1])
v[1]=volume(Fluid$,P=P[1],x=x[1])
s[1]=entropy(Fluid$,P=P[1],x=x[1])
T[1]=temperature(Fluid$,P=P[1],x=x[1])
W_p_s=v[1]*(P[2]-P[1])"SSSF isentropic pump work assuming constant specific volume"
W_p=W_p_s/Eta_p
h[2]=h[1]+W_p "SSSF First Law for the pump"
v[2]=volume(Fluid$,P=P[2],h=h[2])
s[2]=entropy(Fluid$,P=P[2],h=h[2])
T[2]=temperature(Fluid$,P=P[2],h=h[2])
"High Pressure Turbine analysis"
h[3]=enthalpy(Fluid$,T=T[3],P=P[3])
s[3]=entropy(Fluid$,T=T[3],P=P[3])
v[3]=volume(Fluid$,T=T[3],P=P[3])
s_s[4]=s[3]
hs[4]=enthalpy(Fluid$,s=s_s[4],P=P[4])
Ts[4]=temperature(Fluid$,s=s_s[4],P=P[4])
Eta_t=(h[3]-h[4])/(h[3]-hs[4])"Definition of turbine efficiency"
T[4]=temperature(Fluid$,P=P[4],h=h[4])
s[4]=entropy(Fluid$,T=T[4],P=P[4])
v[4]=volume(Fluid$,s=s[4],P=P[4])
h[3] =W_t_hp+h[4]"SSSF First Law for the high pressure turbine"
"Low Pressure Turbine analysis"
P[5]=P[4]
s[5]=entropy(Fluid$,T=T[5],P=P[5])
h[5]=enthalpy(Fluid$,T=T[5],P=P[5])
s_s[6]=s[5]
hs[6]=enthalpy(Fluid$,s=s_s[6],P=P[6])
Ts[6]=temperature(Fluid$,s=s_s[6],P=P[6])
vs[6]=volume(Fluid$,s=s_s[6],P=P[6])
Eta_t=(h[5]-h[6])/(h[5]-hs[6])"Definition of turbine efficiency"
h[5]=W_t_lp+h[6]"SSSF First Law for the low pressure turbine"

```

$x[6]=\text{QUALITY}(\text{Fluid}\$,h=h[6],P=P[6])$

"Boiler analysis"

$Q_{in} + h[2]+h[4]=h[3]+h[5]$ "SSSF First Law for the Boiler"

"Condenser analysis"

$h[6]=Q_{out}+h[1]$ "SSSF First Law for the Condenser"

$T[6]=\text{temperature}(\text{Fluid}\$,h=h[6],P=P[6])$

$s[6]=\text{entropy}(\text{Fluid}\$,h=h[6],P=P[6])$

$x6s\$=x6\$(x[6])$

"Cycle Statistics"

$W_{net}=W_{t_hp}+W_{t_lp}-W_p$

$\text{Eff}=W_{net}/Q_{in}$

"The irreversibilities (or exergy destruction) for each of the processes are:"

$q_{R_23} = - (h[3] - h[2])$ "Heat transfer for the high temperature reservoir to process 2-3"

$i_{23} = T_o^*(s[3] - s[2] + q_{R_23}/T_{R_H})$

$q_{R_45} = - (h[5] - h[4])$ "Heat transfer for the high temperature reservoir to process 4-5"

$i_{45} = T_o^*(s[5] - s[4] + q_{R_45}/T_{R_H})$

$q_{R_61} = (h[6] - h[1])$ "Heat transfer to the low temperature reservoir in process 6-1"

$i_{61} = T_o^*(s[1] - s[6] + q_{R_61}/T_{R_L})$

$i_{34} = T_o^*(s[4] - s[3])$

$i_{56} = T_o^*(s[6] - s[5])$

$i_{12} = T_o^*(s[2] - s[1])$

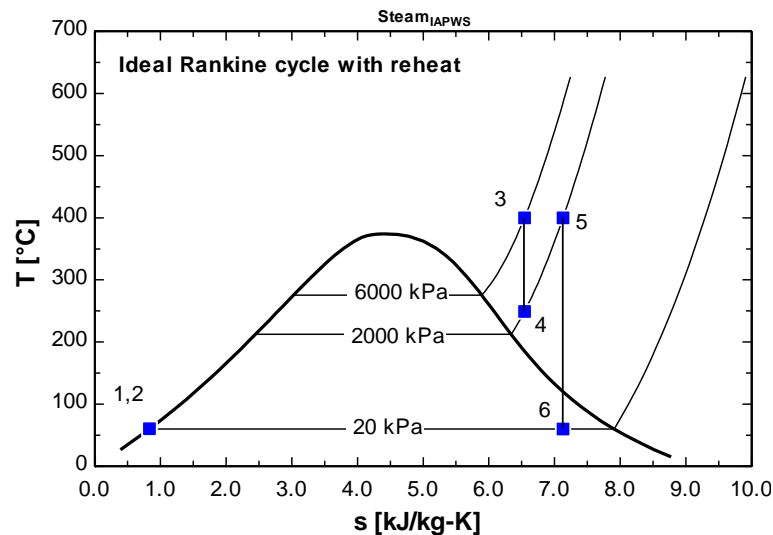

SOLUTION

$\text{Eff}=0.358$

$\text{Eta}_{t}=1$

$i_{12}=0.007$ [kJ/kg]

$i_{34}=-0.000$ [kJ/kg]

$i_{56}=0.000$ [kJ/kg]

$Q_{in}=3268$ [kJ/kg]

$q_{R_23}=-2921$ [kJ/kg]

$q_{R_61}=2098$ [kJ/kg]

$T_{R_H}=1500$ [K]

$W_{net}=1170$ [kJ/kg]

$W_{p,s}=6.083$ [kJ/kg]

$W_{t_lp}=898.7$ [kJ/kg]

$\text{Eta}_p=1$

$\text{Fluid}\$='Steam_IAPWS'$

$i_{23}=1110.378$ [kJ/kg]

$i_{45}=104.554$ [kJ/kg]

$i_{61}=240.601$ [kJ/kg]

$Q_{out}=2098$ [kJ/kg]

$q_{R_45}=-347.3$ [kJ/kg]

$T_o=295$ [K]

$T_{R_L}=295$ [K]

$W_p=6.083$ [kJ/kg]

$W_{t_hp}=277.2$ [kJ/kg]

10-62 The exergy destruction associated with the heat addition process and the expansion process in Prob. 10-37 are to be determined for the specified source and sink temperatures. The exergy of the steam at the boiler exit is also to be determined.

Assumptions 1 Steady operating conditions exist. **2** Kinetic and potential energy changes are negligible.

Analysis From Problem 10-37,

$$\begin{aligned}s_1 &= s_2 = s_f @ 10 \text{ kPa} = 0.6492 \text{ kJ/kg} \cdot \text{K} \\s_3 &= 6.5995 \text{ kJ/kg} \cdot \text{K} \\s_4 &= 6.8464 \text{ kJ/kg} \cdot \text{K} \quad (P_4 = 1 \text{ MPa}, h_4 = 2902.0 \text{ kJ/kg}) \\s_5 &= 7.7642 \text{ kJ/kg} \cdot \text{K} \\s_6 &= 8.3870 \text{ kJ/kg} \cdot \text{K} \quad (P_6 = 10 \text{ kPa}, h_6 = 2664.8 \text{ kJ/kg}) \\h_3 &= 3375.1 \text{ kJ/kg} \\q_{\text{in}} &= 3749.8 \text{ kJ/kg}\end{aligned}$$

The exergy destruction associated with the combined pumping and the heat addition processes is

$$\begin{aligned}x_{\text{destroyed}} &= T_0 \left(s_3 - s_1 + s_5 - s_4 + \frac{q_{R,15}}{T_R} \right) \\&= (285 \text{ K}) \left(6.5995 - 0.6492 + 7.7642 - 6.8464 + \frac{-3749.8 \text{ kJ/kg}}{1600 \text{ K}} \right) \\&= 1289.5 \text{ kJ/kg}\end{aligned}$$

The exergy destruction associated with the pumping process is

$$x_{\text{destroyed}12} \cong w_{p,a} - w_{p,s} = w_{p,a} - v\Delta P = 10.62 - 10.09 = 0.53 \text{ kJ/kg}$$

Thus,

$$x_{\text{destroyed,heating}} = x_{\text{destroyed}} - x_{\text{destroyed}12} = 1289.5 - 0.5 = \mathbf{1289 \text{ kJ/kg}}$$

The exergy destruction associated with the expansion process is

$$\begin{aligned}x_{\text{destroyed}34} &= T_0 \left((s_4 - s_3) + (s_6 - s_5) + \frac{q_{R,36}}{T_R} \right) \\&= (285 \text{ K}) (6.8464 - 6.5995 + 8.3870 - 7.7642) \text{ kJ/kg} \cdot \text{K} \\&= \mathbf{247.9 \text{ kJ/kg}}\end{aligned}$$

The exergy of the steam at the boiler exit is determined from

$$\begin{aligned}\psi_3 &= (h_3 - h_0) - T_0 (s_3 - s_0) + \frac{V_3^2}{2} + qz_3 \\&= (h_3 - h_0) - T_0 (s_3 - s_0)\end{aligned}$$

where

$$\begin{aligned}h_0 &= h @ (285 \text{ K}, 100 \text{ kPa}) \cong h_f @ 285 \text{ K} = 50.51 \text{ kJ/kg} \\s_0 &= s @ (285 \text{ K}, 100 \text{ kPa}) \cong s_f @ 285 \text{ K} = 0.1806 \text{ kJ/kg} \cdot \text{K}\end{aligned}$$

Thus,

$$\psi_3 = (3375.1 - 50.51) \text{ kJ/kg} - (285 \text{ K}) (6.5995 - 0.1806) \text{ kJ/kg} \cdot \text{K} = \mathbf{1495 \text{ kJ/kg}}$$

10-63 The exergy destruction associated with the regenerative cycle described in Prob. 10-45 is to be determined for the specified source and sink temperatures.

Assumptions 1 Steady operating conditions exist. 2 Kinetic and potential energy changes are negligible.

Analysis From Problem 10-45, $q_{\text{in}} = 2692.2 \text{ kJ/kg}$ and $q_{\text{out}} = 1675.7 \text{ kJ/kg}$. Then the exergy destruction associated with this regenerative cycle is

$$x_{\text{destroyedcycle}} = T_0 \left(\frac{q_{\text{out}}}{T_L} - \frac{q_{\text{in}}}{T_H} \right) = (290 \text{ K}) \left(\frac{1675.7 \text{ kJ/kg}}{290 \text{ K}} - \frac{2692.2 \text{ kJ/kg}}{1500 \text{ K}} \right) = \mathbf{1155 \text{ kJ/kg}}$$

10-64 The exergy destruction associated with the reheating and regeneration processes described in Prob. 10-55 are to be determined for the specified source and sink temperatures.

Assumptions 1 Steady operating conditions exist. 2 Kinetic and potential energy changes are negligible.

Analysis From Problem 10-55 and the steam tables,

$$y = 0.2016$$

$$s_3 = s_{f@0.8\text{MPa}} = 2.0457 \text{ kJ/kg} \cdot \text{K}$$

$$s_5 = s_6 = 6.7585 \text{ kJ/kg} \cdot \text{K}$$

$$s_7 = 7.8692 \text{ kJ/kg} \cdot \text{K}$$

$$s_1 = s_2 = s_{f@10\text{kPa}} = 0.6492 \text{ kJ/kg} \cdot \text{K}$$

$$q_{\text{reheat}} = h_7 - h_6 = 3481.3 - 2812.7 = 668.6 \text{ kJ/kg}$$

Then the exergy destruction associated with reheat and regeneration processes are

$$\begin{aligned} x_{\text{destroyedreheat}} &= T_0 \left(s_7 - s_6 + \frac{q_{R,67}}{T_R} \right) \\ &= (290 \text{ K}) \left(7.8692 - 6.7585 + \frac{-668.6 \text{ kJ/kg}}{1800 \text{ K}} \right) \\ &= \mathbf{214.3 \text{ kJ/kg}} \end{aligned}$$

$$\begin{aligned} x_{\text{destroyedregen}} &= T_0 s_{\text{gen}} = T_0 \left(\sum m_e s_e - \sum m_i s_i + \frac{q_{\text{surr}}}{T_0} \right) = T_0 (s_3 - y s_6 - (1-y) s_2) \\ &= (290 \text{ K}) [2.0457 - (0.2016)(6.7585) - (1-0.2016)(0.6492)] \\ &= \mathbf{47.8 \text{ kJ/kg}} \end{aligned}$$

10-65 A single-flash geothermal power plant uses hot geothermal water at 230°C as the heat source. The power output from the turbine, the thermal efficiency of the plant, the exergy of the geothermal liquid at the exit of the flash chamber, and the exergy destructions and exergy efficiencies for the flash chamber, the turbine, and the entire plant are to be determined.

Assumptions 1 Steady operating conditions exist. 2 Kinetic and potential energy changes are negligible.

Analysis (a) We use properties of water for geothermal water (Tables A-4, A-5, and A-6)

$$\left. \begin{aligned} T_1 = 230^\circ\text{C} \\ x_1 = 0 \end{aligned} \right\} \begin{aligned} h_1 = 990.14 \text{ kJ/kg} \\ s_1 = 2.6100 \text{ kJ/kg}\cdot\text{K} \end{aligned}$$

$$\left. \begin{aligned} P_2 = 500 \text{ kPa} \\ h_2 = h_1 = 990.14 \text{ kJ/kg} \end{aligned} \right\} \begin{aligned} x_2 = 0.1661 \\ s_2 = 2.6841 \text{ kJ/kg}\cdot\text{K} \end{aligned}$$

$$\begin{aligned} \dot{m}_3 &= x_2 \dot{m}_1 \\ &= (0.1661)(230 \text{ kg/s}) \\ &= 38.19 \text{ kg/s} \end{aligned}$$

$$\left. \begin{aligned} P_3 = 500 \text{ kPa} \\ x_3 = 1 \end{aligned} \right\} \begin{aligned} h_3 = 2748.1 \text{ kJ/kg} \\ s_3 = 6.8207 \text{ kJ/kg}\cdot\text{K} \end{aligned}$$

$$\left. \begin{aligned} P_4 = 10 \text{ kPa} \\ x_4 = 0.95 \end{aligned} \right\} \begin{aligned} h_4 = 2464.3 \text{ kJ/kg} \\ s_4 = 7.7739 \text{ kJ/kg}\cdot\text{K} \end{aligned}$$

$$\left. \begin{aligned} P_6 = 500 \text{ kPa} \\ x_6 = 0 \end{aligned} \right\} \begin{aligned} h_6 = 640.09 \text{ kJ/kg} \\ s_6 = 1.8604 \text{ kJ/kg}\cdot\text{K} \end{aligned}$$

$$\dot{m}_6 = \dot{m}_1 - \dot{m}_3 = 230 - 38.19 = 191.81 \text{ kg/s}$$

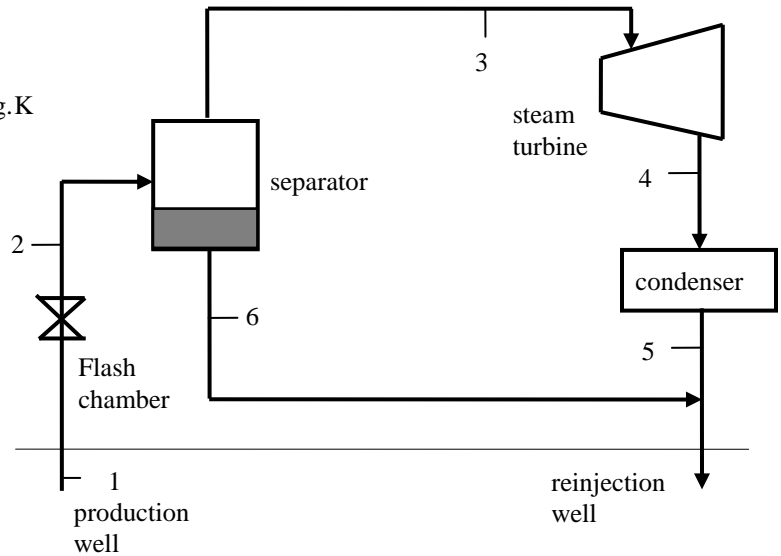

The power output from the turbine is

$$\dot{W}_T = \dot{m}_3 (h_3 - h_4) = (38.19 \text{ kg/s})(2748.1 - 2464.3) \text{ kJ/kg} = \mathbf{10,842 \text{ kW}}$$

We use saturated liquid state at the standard temperature for dead state properties

$$\left. \begin{aligned} T_0 = 25^\circ\text{C} \\ x_0 = 0 \end{aligned} \right\} \begin{aligned} h_0 = 104.83 \text{ kJ/kg} \\ s_0 = 0.3672 \text{ kJ/kg}\cdot\text{K} \end{aligned}$$

$$\dot{E}_{\text{in}} = \dot{m}_1 (h_1 - h_0) = (230 \text{ kg/s})(990.14 - 104.83) \text{ kJ/kg} = 203,622 \text{ kW}$$

$$\eta_{\text{th}} = \frac{\dot{W}_{T,\text{out}}}{\dot{E}_{\text{in}}} = \frac{10,842}{203,622} = 0.0532 = \mathbf{5.3\%}$$

(b) The specific exergies at various states are

$$\psi_1 = h_1 - h_0 - T_0 (s_1 - s_0) = (990.14 - 104.83) \text{ kJ/kg} - (298 \text{ K})(2.6100 - 0.3672) \text{ kJ/kg}\cdot\text{K} = 216.53 \text{ kJ/kg}$$

$$\psi_2 = h_2 - h_0 - T_0 (s_2 - s_0) = (990.14 - 104.83) \text{ kJ/kg} - (298 \text{ K})(2.6841 - 0.3672) \text{ kJ/kg}\cdot\text{K} = 194.44 \text{ kJ/kg}$$

$$\psi_3 = h_3 - h_0 - T_0 (s_3 - s_0) = (2748.1 - 104.83) \text{ kJ/kg} - (298 \text{ K})(6.8207 - 0.3672) \text{ kJ/kg}\cdot\text{K} = 719.10 \text{ kJ/kg}$$

$$\psi_4 = h_4 - h_0 - T_0 (s_4 - s_0) = (2464.3 - 104.83) \text{ kJ/kg} - (298 \text{ K})(7.7739 - 0.3672) \text{ kJ/kg}\cdot\text{K} = 151.05 \text{ kJ/kg}$$

$$\psi_6 = h_6 - h_0 - T_0 (s_6 - s_0) = (640.09 - 104.83) \text{ kJ/kg} - (298 \text{ K})(1.8604 - 0.3672) \text{ kJ/kg}\cdot\text{K} = 89.97 \text{ kJ/kg}$$

The exergy of geothermal water at state 6 is

$$\dot{X}_6 = \dot{m}_6 \psi_6 = (191.81 \text{ kg/s})(89.97 \text{ kJ/kg}) = \mathbf{17,257 \text{ kW}}$$

(c) Turbine:

$$\dot{X}_{\text{dest},T} = \dot{m}_3 (\psi_3 - \psi_4) - \dot{W}_T = (38.19 \text{ kg/s})(719.10 - 151.05) \text{ kJ/kg} - 10,842 \text{ kW} = \mathbf{10,854 \text{ kW}}$$

$$\eta_{II,T} = \frac{\dot{W}_T}{\dot{m}_3(\psi_3 - \psi_4)} = \frac{10,842 \text{ kW}}{(38.19 \text{ kg/s})(719.10 - 151.05) \text{ kJ/kg}} = 0.500 = \mathbf{50.0\%}$$

(d) Plant:

$$\dot{X}_{\text{in,Plant}} = \dot{m}_1\psi_1 = (230 \text{ kg/s})(216.53 \text{ kJ/kg}) = 49,802 \text{ kW}$$

$$\dot{X}_{\text{dest,Plant}} = \dot{X}_{\text{in,Plant}} - \dot{W}_T = 49,802 - 10,842 = \mathbf{38,960 \text{ kW}}$$

$$\eta_{II,\text{Plant}} = \frac{\dot{W}_T}{\dot{X}_{\text{in,Plant}}} = \frac{10,842 \text{ kW}}{49,802 \text{ kW}} = 0.2177 = \mathbf{21.8\%}$$

Cogeneration

10-66C The utilization factor of a cogeneration plant is the ratio of the energy utilized for a useful purpose to the total energy supplied. It could be unity for a plant that does not produce any power.

10-67C No. A cogeneration plant may involve throttling, friction, and heat transfer through a finite temperature difference, and still have a utilization factor of unity.

10-68C Yes, if the cycle involves no irreversibilities such as throttling, friction, and heat transfer through a finite temperature difference.

10-69 A cogeneration plant is to generate power and process heat. Part of the steam extracted from the turbine at a relatively high pressure is used for process heating. The net power produced and the utilization factor of the plant are to be determined.

Assumptions 1 Steady operating conditions exist. 2 Kinetic and potential energy changes are negligible.

Analysis From the steam tables (Tables A-4, A-5, and A-6),

$$h_1 = h_f @ 10 \text{ kPa} = 191.81 \text{ kJ/kg}$$

$$v_1 = v_f @ 10 \text{ kPa} = 0.00101 \text{ m}^3/\text{kg}$$

$$w_{pI, \text{in}} = v_1(P_2 - P_1) \\ = (0.00101 \text{ m}^3/\text{kg})(1200 - 10 \text{ kPa}) \left(\frac{1 \text{ kJ}}{1 \text{ kPa} \cdot \text{m}^3} \right) \\ = 1.20 \text{ kJ/kg}$$

$$h_2 = h_1 + w_{pI, \text{in}} = 191.81 + 1.20 = 193.01 \text{ kJ/kg}$$

$$h_3 = h_f @ 1.2 \text{ MPa} = 798.33 \text{ kJ/kg}$$

Mixing chamber:

$$\dot{E}_{\text{in}} - \dot{E}_{\text{out}} = \Delta \dot{E}_{\text{system}} \stackrel{\text{no (steady)}}{=} 0 \longrightarrow \dot{E}_{\text{in}} = \dot{E}_{\text{out}} \\ \sum \dot{m}_i h_i = \sum \dot{m}_e h_e \longrightarrow \dot{m}_4 h_4 = \dot{m}_2 h_2 + \dot{m}_3 h_3$$

$$\text{or, } h_4 = \frac{\dot{m}_2 h_2 + \dot{m}_3 h_3}{\dot{m}_4} = \frac{(22.50)(192.41) + (7.50)(798.33)}{30} = 344.34 \text{ kJ/kg}$$

$$v_4 \cong v_f @ h_f = 344.34 \text{ kJ/kg} = 0.001031 \text{ m}^3/\text{kg}$$

$$w_{pII, \text{in}} = v_4(P_5 - P_4) \\ = (0.001031 \text{ m}^3/\text{kg})(4000 - 1200 \text{ kPa}) \left(\frac{1 \text{ kJ}}{1 \text{ kPa} \cdot \text{m}^3} \right) \\ = 2.89 \text{ kJ/kg}$$

$$h_5 = h_4 + w_{pII, \text{in}} = 344.34 + 2.89 = 347.22 \text{ kJ/kg}$$

$$P_6 = 4 \text{ MPa} \left. \begin{array}{l} h_6 = 3446.0 \text{ kJ/kg} \\ T_6 = 500^\circ\text{C} \end{array} \right\} s_6 = 7.0922 \text{ kJ/kg} \cdot \text{K}$$

$$P_7 = 1.2 \text{ MPa} \left. \begin{array}{l} h_7 = 3080.4 \text{ kJ/kg} \\ s_7 = s_6 \end{array} \right\}$$

$$P_8 = 10 \text{ kPa} \left. \begin{array}{l} x_8 = \frac{s_8 - s_f}{s_{fg}} = \frac{7.0922 - 0.6492}{7.4996} = 0.8591 \\ s_8 = s_6 \end{array} \right\}$$

$$h_8 = h_f + x_8 h_{fg} = 191.81 + (0.8591)(2392.1) = 2246.9 \text{ kJ/kg}$$

Then,

$$\dot{W}_{T, \text{out}} = \dot{m}_6(h_6 - h_7) + \dot{m}_8(h_7 - h_8) \\ = (55 \text{ kg/s})(3446.0 - 3080.4) \text{ kJ/kg} + (0.75 \times 55 \text{ kg/s})(3080.4 - 2246.9) \text{ kJ/kg} = 54,494 \text{ kW}$$

$$\dot{W}_{p, \text{in}} = \dot{m}_1 w_{pI, \text{in}} + \dot{m}_4 w_{pII, \text{in}} = (0.75 \times 55 \text{ kg/s})(1.20 \text{ kJ/kg}) + (55 \text{ kg/s})(2.89 \text{ kJ/kg}) = 208.3 \text{ kW}$$

$$\dot{W}_{\text{net}} = \dot{W}_{T, \text{out}} - \dot{W}_{p, \text{in}} = 54,494 - 208.3 = \mathbf{54,285 \text{ kW}}$$

$$\text{Also, } \dot{Q}_{\text{process}} = \dot{m}_7(h_7 - h_3) = (0.25 \times 55 \text{ kg/s})(3080.4 - 798.33) \text{ kJ/kg} = 31,379 \text{ kW}$$

$$\dot{Q}_{\text{in}} = \dot{m}_5(h_6 - h_5) = (55 \text{ kg/s})(3446.0 - 347.22) = 170,435 \text{ kW}$$

$$\text{and } \varepsilon_u = \frac{\dot{W}_{\text{net}} + \dot{Q}_{\text{process}}}{\dot{Q}_{\text{in}}} = \frac{54,285 + 31,379}{170,435} = 0.5026 = \mathbf{50.3\%}$$

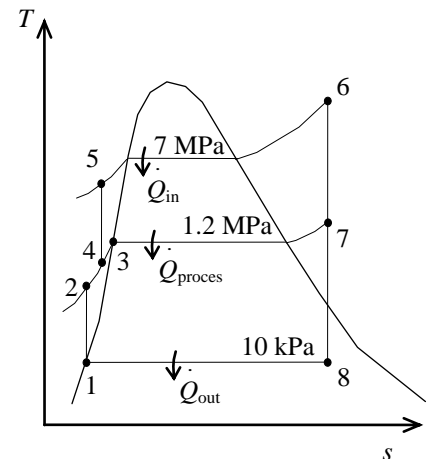
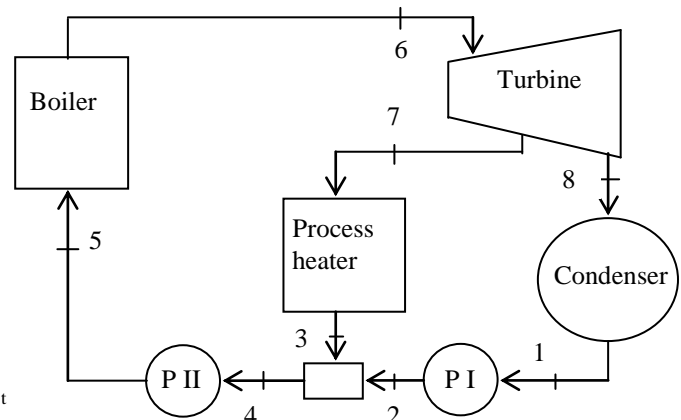

10-70E A large food-processing plant requires steam at a relatively high pressure, which is extracted from the turbine of a cogeneration plant. The rate of heat transfer to the boiler and the power output of the cogeneration plant are to be determined.

Assumptions 1 Steady operating conditions exist. 2 Kinetic and potential energy changes are negligible.

Analysis (a) From the steam tables (Tables A-4E, A-5E, and A-6E),

$$h_1 = h_f @ 2 \text{ psia} = 94.02 \text{ Btu/lbm}$$

$$\nu_1 = \nu_f @ 2 \text{ psia} = 0.01623 \text{ ft}^3/\text{lbm}$$

$$\begin{aligned} w_{pI, \text{in}} &= \nu_1 (P_2 - P_1) / \eta_p \\ &= \frac{1}{0.86} (0.01623 \text{ ft}^3/\text{lbm})(140 - 2) \text{ psia} \\ &\quad \times \left(\frac{1 \text{ Btu}}{5.4039 \text{ psia} \cdot \text{ft}^3} \right) \\ &= 0.48 \text{ Btu/lbm} \end{aligned}$$

$$h_2 = h_1 + w_{pI, \text{in}} = 94.02 + 0.48 = 94.50 \text{ Btu/lbm}$$

$$h_3 = h_f @ 140 \text{ psia} = 324.92 \text{ Btu/lbm}$$

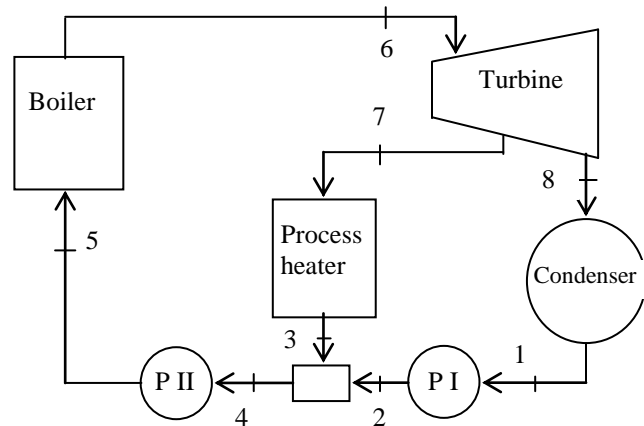

Mixing chamber:

$$\dot{E}_{\text{in}} - \dot{E}_{\text{out}} = \Delta \dot{E}_{\text{system}} \stackrel{\approx 0 \text{ (steady)}}{=} 0$$

$$\dot{E}_{\text{in}} = \dot{E}_{\text{out}}$$

$$\sum \dot{m}_i h_i = \sum \dot{m}_e h_e \quad \longrightarrow \quad \dot{m}_4 h_4 = \dot{m}_2 h_2 + \dot{m}_3 h_3$$

or,

$$h_4 = \frac{\dot{m}_2 h_2 + \dot{m}_3 h_3}{\dot{m}_4} = \frac{(8.5)(94.50) + (1.5)(324.92)}{10} = 129.07 \text{ Btu/lbm}$$

$$\nu_4 \cong \nu_f @ h_f = 129.07 \text{ Btu/lbm} = 0.01640 \text{ ft}^3/\text{lbm}$$

$$\begin{aligned} w_{pII, \text{in}} &= \nu_4 (P_5 - P_4) / \eta_p \\ &= (0.01640 \text{ ft}^3/\text{lbm})(800 - 140 \text{ psia}) \left(\frac{1 \text{ Btu}}{5.4039 \text{ psia} \cdot \text{ft}^3} \right) / (0.86) \\ &= 2.33 \text{ Btu/lbm} \end{aligned}$$

$$h_5 = h_4 + w_{pII, \text{in}} = 129.07 + 2.33 = 131.39 \text{ Btu/lbm}$$

$$\left. \begin{aligned} P_6 &= 800 \text{ psia} \\ T_6 &= 1000^\circ\text{F} \end{aligned} \right\} \begin{aligned} h_6 &= 1512.2 \text{ Btu/lbm} \\ s_6 &= 1.6812 \text{ Btu/lbm} \cdot \text{R} \end{aligned}$$

$$\left. \begin{aligned} P_{7s} &= 140 \text{ psia} \\ s_{7s} &= s_6 \end{aligned} \right\} h_{7s} = 1287.5 \text{ Btu/lbm}$$

$$\left. \begin{aligned} P_{8s} &= 2 \text{ psia} \\ s_{8s} &= s_6 \end{aligned} \right\} \begin{aligned} x_{8s} &= \frac{s_{8s} - s_f}{s_{fg}} = \frac{1.6812 - 0.17499}{1.74444} = 0.8634 \\ h_{8s} &= h_f + x_{8s} h_{fg} = 94.02 + (0.8634)(1021.7) = 976.21 \text{ Btu/lbm} \end{aligned}$$

Then, $\dot{Q}_{\text{in}} = \dot{m}_5 (h_6 - h_5) = (10 \text{ lbm/s})(1512.2 - 131.39) \text{ Btu/lbm} = \mathbf{13,810 \text{ Btu/s}}$

(b) $\dot{W}_{T, \text{out}} = \eta_T \dot{W}_{T, s} = \eta_T [\dot{m}_6 (h_6 - h_{7s}) + \dot{m}_8 (h_{7s} - h_{8s})]$
 $= (0.86) [(10 \text{ lbm/s})(1512.2 - 1287.5) \text{ Btu/lbm} + (1.5 \text{ lbm/s})(1287.5 - 976.21) \text{ Btu/lbm}]$
 $= 4208 \text{ Btu/s} = \mathbf{4440 \text{ kW}}$

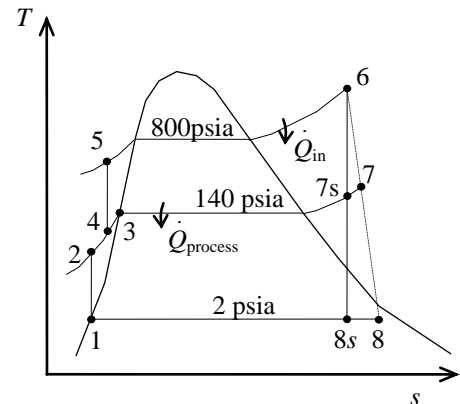

10-71 A cogeneration plant has two modes of operation. In the first mode, all the steam leaving the turbine at a relatively high pressure is routed to the process heater. In the second mode, 60 percent of the steam is routed to the process heater and remaining is expanded to the condenser pressure. The power produced and the rate at which process heat is supplied in the first mode, and the power produced and the rate of process heat supplied in the second mode are to be determined.

Assumptions 1 Steady operating conditions exist. 2 Kinetic and potential energy changes are negligible.

Analysis (a) From the steam tables (Tables A-4, A-5, and A-6),

$$h_1 = h_f @ 20 \text{ kPa} = 251.42 \text{ kJ/kg}$$

$$\nu_1 = \nu_f @ 20 \text{ kPa} = 0.001017 \text{ m}^3/\text{kg}$$

$$\begin{aligned} w_{pI,in} &= \nu_1 (P_2 - P_1) \\ &= (0.001017 \text{ m}^3/\text{kg})(10,000 - 20 \text{ kPa}) \left(\frac{1 \text{ kJ}}{1 \text{ kPa} \cdot \text{m}^3} \right) \\ &= 10.15 \text{ kJ/kg} \end{aligned}$$

$$h_2 = h_1 + w_{pI,in} = 251.42 + 10.15 = 261.57 \text{ kJ/kg}$$

$$h_3 = h_f @ 0.5 \text{ MPa} = 640.09 \text{ kJ/kg}$$

$$\nu_3 = \nu_f @ 0.5 \text{ MPa} = 0.001093 \text{ m}^3/\text{kg}$$

$$\begin{aligned} w_{pII,in} &= \nu_3 (P_4 - P_3) \\ &= (0.001093 \text{ m}^3/\text{kg})(10,000 - 500 \text{ kPa}) \left(\frac{1 \text{ kJ}}{1 \text{ kPa} \cdot \text{m}^3} \right) \\ &= 10.38 \text{ kJ/kg} \end{aligned}$$

$$h_4 = h_3 + w_{pII,in} = 640.09 + 10.38 = 650.47 \text{ kJ/kg}$$

Mixing chamber:

$$\begin{aligned} \dot{E}_{in} - \dot{E}_{out} &= \Delta \dot{E}_{system} \stackrel{\approx 0 \text{ (steady)}}{=} 0 \rightarrow \dot{E}_{in} = \dot{E}_{out} \\ \sum \dot{m}_i h_i &= \sum \dot{m}_e h_e \rightarrow \dot{m}_5 h_5 = \dot{m}_2 h_2 + \dot{m}_4 h_4 \end{aligned}$$

$$\text{or, } h_5 = \frac{\dot{m}_2 h_2 + \dot{m}_4 h_4}{\dot{m}_5} = \frac{(2)(261.57) + (3)(650.47)}{5} = 494.91 \text{ kJ/kg}$$

$$\left. \begin{aligned} P_6 &= 10 \text{ MPa} \\ T_6 &= 450^\circ\text{C} \end{aligned} \right\} \begin{aligned} h_6 &= 3242.4 \text{ kJ/kg} \\ s_6 &= 6.4219 \text{ kJ/kg} \cdot \text{K} \end{aligned}$$

$$\left. \begin{aligned} P_7 &= 0.5 \text{ MPa} \\ s_7 &= s_6 \end{aligned} \right\} \begin{aligned} x_7 &= \frac{s_7 - s_f}{s_{fg}} = \frac{6.4219 - 1.8604}{4.9603} = 0.9196 \\ h_7 &= h_f + x_7 h_{fg} = 640.09 + (0.9196)(2108.0) = 2578.6 \text{ kJ/kg} \end{aligned}$$

$$\left. \begin{aligned} P_8 &= 20 \text{ kPa} \\ s_8 &= s_6 \end{aligned} \right\} \begin{aligned} x_8 &= \frac{s_8 - s_f}{s_{fg}} = \frac{6.4219 - 0.8320}{7.0752} = 0.7901 \\ h_8 &= h_f + x_8 h_{fg} = 251.42 + (0.7901)(2357.5) = 2114.0 \text{ kJ/kg} \end{aligned}$$

When the entire steam is routed to the process heater,

$$\dot{W}_{T,out} = \dot{m}_6 (h_6 - h_7) = (5 \text{ kg/s})(3242.4 - 2578.6) \text{ kJ/kg} = \mathbf{3319 \text{ kW}}$$

$$\dot{Q}_{process} = \dot{m}_7 (h_7 - h_3) = (5 \text{ kg/s})(2578.6 - 640.09) \text{ kJ/kg} = \mathbf{9693 \text{ kW}}$$

(b) When only 60% of the steam is routed to the process heater,

$$\begin{aligned} \dot{W}_{T,out} &= \dot{m}_6 (h_6 - h_7) + \dot{m}_8 (h_7 - h_8) \\ &= (5 \text{ kg/s})(3242.4 - 2578.6) \text{ kJ/kg} + (2 \text{ kg/s})(2578.6 - 2114.0) \text{ kJ/kg} = \mathbf{4248 \text{ kW}} \end{aligned}$$

$$\dot{Q}_{process} = \dot{m}_7 (h_7 - h_3) = (3 \text{ kg/s})(2578.6 - 640.09) \text{ kJ/kg} = \mathbf{5816 \text{ kW}}$$

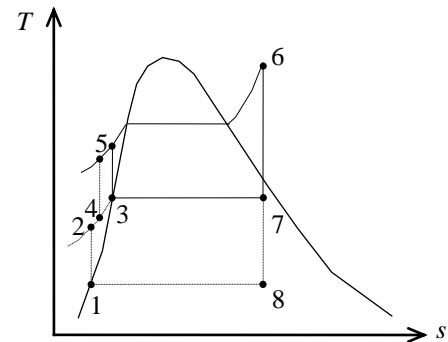
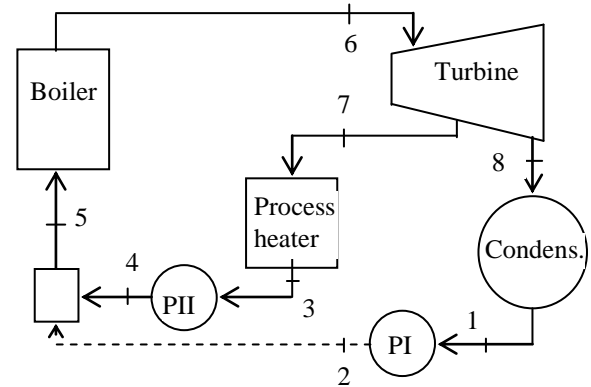

10-72 A cogeneration plant modified with regeneration is to generate power and process heat. The mass flow rate of steam through the boiler for a net power output of 25 MW is to be determined.

Assumptions 1 Steady operating conditions exist. 2 Kinetic and potential energy changes are negligible.

Analysis From the steam tables (Tables A-4, A-5, and A-6),

$$h_1 = h_f @ 10 \text{ kPa} = 191.81 \text{ kJ/kg}$$

$$v_1 = v_f @ 10 \text{ kPa} = 0.00101 \text{ m}^3/\text{kg}$$

$$\begin{aligned} w_{pI,in} &= v_1(P_2 - P_1) \\ &= (0.00101 \text{ m}^3/\text{kg})(1600 - 10 \text{ kPa}) \left(\frac{1 \text{ kJ}}{1 \text{ kPa} \cdot \text{m}^3} \right) \\ &= 1.61 \text{ kJ/kg} \end{aligned}$$

$$h_2 = h_1 + w_{pI,in} = 191.81 + 1.61 = 193.41 \text{ kJ/kg}$$

$$h_3 = h_4 = h_9 = h_f @ 1.6 \text{ MPa} = 858.44 \text{ kJ/kg}$$

$$v_4 = v_f @ 1.6 \text{ MPa} = 0.001159 \text{ m}^3/\text{kg}$$

$$\begin{aligned} w_{pII,in} &= v_4(P_5 - P_4) \\ &= (0.001159 \text{ m}^3/\text{kg})(9000 - 400 \text{ kPa}) \left(\frac{1 \text{ kJ}}{1 \text{ kPa} \cdot \text{m}^3} \right) \\ &= 8.57 \text{ kJ/kg} \end{aligned}$$

$$h_5 = h_4 + w_{pII,in} = 858.44 + 8.57 = 867.02 \text{ kJ/kg}$$

$$\left. \begin{array}{l} P_6 = 9 \text{ MPa} \\ T_6 = 400^\circ\text{C} \end{array} \right\} \begin{array}{l} h_6 = 3118.8 \text{ kJ/kg} \\ s_6 = 6.2876 \text{ kJ/kg} \cdot \text{K} \end{array}$$

$$\left. \begin{array}{l} P_7 = 1.6 \text{ MPa} \\ s_7 = s_6 \end{array} \right\} \begin{array}{l} x_7 = \frac{s_7 - s_f}{s_{fg}} = \frac{6.2876 - 2.3435}{4.0765} = 0.9675 \\ h_7 = h_f + x_7 h_{fg} = 858.44 + (0.9675)(1934.4) = 2730.0 \text{ kJ/kg} \end{array}$$

$$\left. \begin{array}{l} P_8 = 10 \text{ kPa} \\ s_8 = s_6 \end{array} \right\} \begin{array}{l} x_8 = \frac{s_8 - s_f}{s_{fg}} = \frac{6.2876 - 0.6492}{7.4996} = 0.7518 \\ h_8 = h_f + x_8 h_{fg} = 191.81 + (0.7518)(2392.1) = 1990.2 \text{ kJ/kg} \end{array}$$

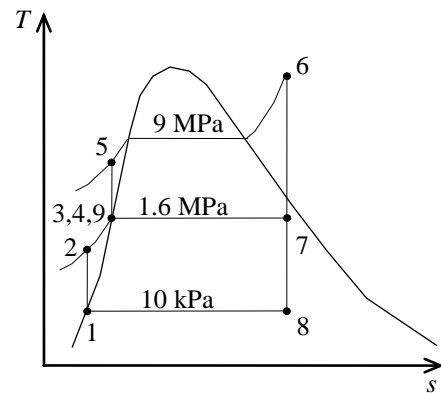
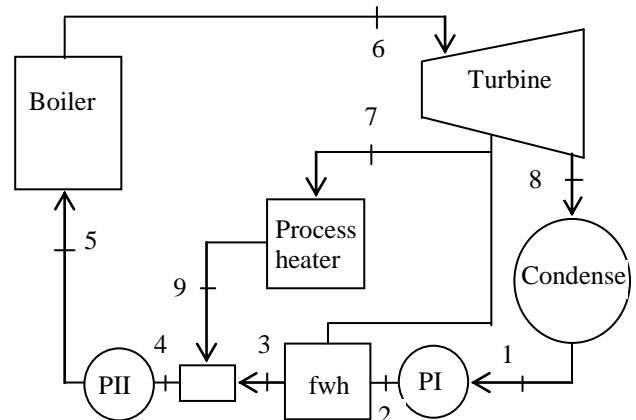

Then, per kg of steam flowing through the boiler, we have

$$\begin{aligned} w_{T,out} &= (h_6 - h_7) + (1 - y)(h_7 - h_8) \\ &= (3118.8 - 2730.0) \text{ kJ/kg} + (1 - 0.35)(2730.0 - 1990.2) \text{ kJ/kg} \\ &= 869.7 \text{ kJ/kg} \end{aligned}$$

$$\begin{aligned} w_{p,in} &= (1 - y)w_{pI,in} + w_{pII,in} \\ &= (1 - 0.35)(1.61 \text{ kJ/kg}) + (8.57 \text{ kJ/kg}) \\ &= 9.62 \text{ kJ/kg} \end{aligned}$$

$$w_{net} = w_{T,out} - w_{p,in} = 869.7 - 9.62 = 860.1 \text{ kJ/kg}$$

Thus,

$$\dot{m} = \frac{\dot{W}_{net}}{w_{net}} = \frac{25,000 \text{ kJ/s}}{860.1 \text{ kJ/kg}} = \mathbf{29.1 \text{ kg/s}}$$



10-73 Problem 10-72 is reconsidered. The effect of the extraction pressure for removing steam from the turbine to be used for the process heater and open feedwater heater on the required mass flow rate is to be investigated.

Analysis The problem is solved using EES, and the solution is given below.

"Input Data"

```

y = 0.35 "fraction of steam extracted from turbine for feedwater heater and process heater"
P[6] = 9000 [kPa]
T[6] = 400 [C]
P_extract=1600 [kPa]
P[7] = P_extract
P_cond=10 [kPa]
P[8] = P_cond
W_dot_net=25 [MW]*Convert(MW, kW)
Eta_turb= 100/100 "Turbine isentropic efficiency"
Eta_pump = 100/100 "Pump isentropic efficiency"
P[1] = P[8]
P[2]=P[7]
P[3]=P[7]
P[4] = P[7]
P[5]=P[6]
P[9] = P[7]

```

"Condenser exit pump or Pump 1 analysis"

```
Fluid$='Steam_IAPWS'
```

```

h[1]=enthalpy(Fluid$,P=P[1],x=0) {Sat'd liquid}
v1=volume(Fluid$,P=P[1],x=0)
s[1]=entropy(Fluid$,P=P[1],x=0)
T[1]=temperature(Fluid$,P=P[1],x=0)
w_pump1_s=v1*(P[2]-P[1])"SSSF isentropic pump work assuming constant specific volume"
w_pump1=w_pump1_s/Eta_pump "Definition of pump efficiency"
h[1]+w_pump1= h[2] "Steady-flow conservation of energy"
s[2]=entropy(Fluid$,P=P[2],h=h[2])
T[2]=temperature(Fluid$,P=P[2],h=h[2])

```

"Open Feedwater Heater analysis:"

```

z*h[7] + (1- y)*h[2] = (1- y + z)*h[3] "Steady-flow conservation of energy"
h[3]=enthalpy(Fluid$,P=P[3],x=0)
T[3]=temperature(Fluid$,P=P[3],x=0) "Condensate leaves heater as sat. liquid at P[3]"
s[3]=entropy(Fluid$,P=P[3],x=0)

```

"Process heater analysis:"

```

(y - z)*h[7] = q_process + (y - z)*h[9] "Steady-flow conservation of energy"
Q_dot_process = m_dot*(y - z)*q_process"[kW]"
h[9]=enthalpy(Fluid$,P=P[9],x=0)
T[9]=temperature(Fluid$,P=P[9],x=0) "Condensate leaves heater as sat. liquid at P[3]"
s[9]=entropy(Fluid$,P=P[9],x=0)

```

"Mixing chamber at 3, 4, and 9:"

```

(y-z)*h[9] + (1-y+z)*h[3] = 1*h[4] "Steady-flow conservation of energy"
T[4]=temperature(Fluid$,P=P[4],h=h[4]) "Condensate leaves heater as sat. liquid at P[3]"
s[4]=entropy(Fluid$,P=P[4],h=h[4])

```

"Boiler condensate pump or Pump 2 analysis"

```

v4=volume(Fluid$,P=P[4],x=0)
w_pump2_s=v4*(P[5]-P[4])"SSSF isentropic pump work assuming constant specific volume"
w_pump2=w_pump2_s/Eta_pump "Definition of pump efficiency"
h[4]+w_pump2= h[5] "Steady-flow conservation of energy"

```

s[5]=entropy(Fluid\$,P=P[5],h=h[5])
 T[5]=temperature(Fluid\$,P=P[5],h=h[5])

"Boiler analysis"

q_in + h[5]=h[6]"SSSF conservation of energy for the Boiler"
 h[6]=enthalpy(Fluid\$, T=T[6], P=P[6])
 s[6]=entropy(Fluid\$, T=T[6], P=P[6])

"Turbine analysis"

ss[7]=s[6]
 hs[7]=enthalpy(Fluid\$,s=ss[7],P=P[7])
 Ts[7]=temperature(Fluid\$,s=ss[7],P=P[7])
 h[7]=h[6]-Eta_turb*(h[6]-hs[7])"Definition of turbine efficiency for high pressure stages"
 T[7]=temperature(Fluid\$,P=P[7],h=h[7])
 s[7]=entropy(Fluid\$,P=P[7],h=h[7])
 ss[8]=s[7]
 hs[8]=enthalpy(Fluid\$,s=ss[8],P=P[8])
 Ts[8]=temperature(Fluid\$,s=ss[8],P=P[8])
 h[8]=h[7]-Eta_turb*(h[7]-hs[8])"Definition of turbine efficiency for low pressure stages"
 T[8]=temperature(Fluid\$,P=P[8],h=h[8])
 s[8]=entropy(Fluid\$,P=P[8],h=h[8])
 h[6] =y*h[7] + (1- y)*h[8] + w_turb "SSSF conservation of energy for turbine"

"Condenser analysis"

(1- y)*h[8]=q_out+(1- y)*h[1]"SSSF First Law for the Condenser"

"Cycle Statistics"

w_net=w_turb - ((1- y)*w_pump1+ w_pump2)
 Eta_th=w_net/q_in
 W_dot_net = m_dot * w_net

P _{extract} [kPa]	η _{th}	m [kg/s]	Q _{process} [kW]
200	0.3778	25.4	2770
400	0.3776	26.43	2137
600	0.3781	27.11	1745
800	0.3787	27.63	1459
1000	0.3794	28.07	1235
1200	0.3802	28.44	1053
1400	0.3811	28.77	900.7
1600	0.3819	29.07	770.9
1800	0.3828	29.34	659
2000	0.3837	29.59	561.8

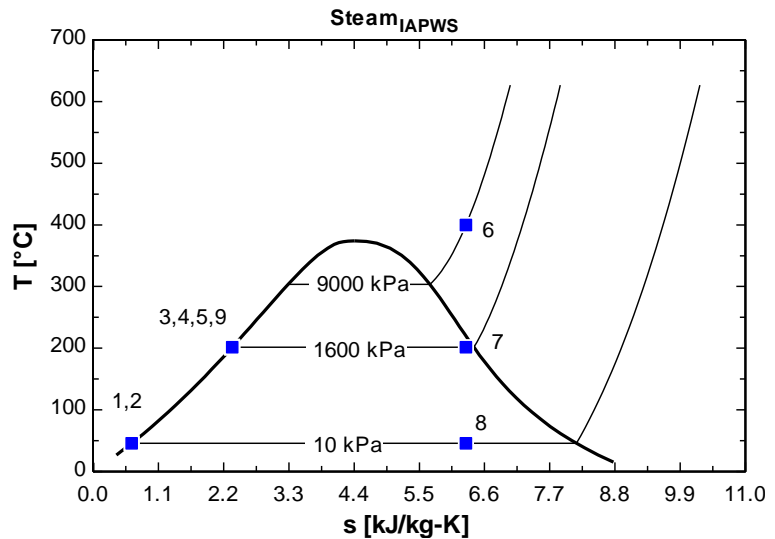

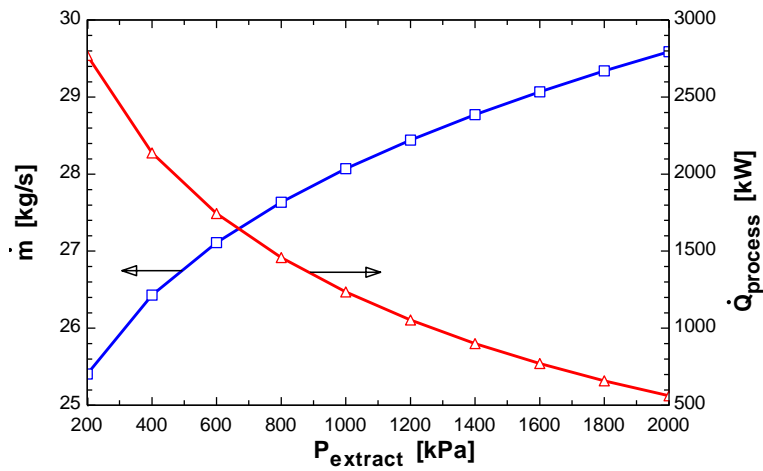
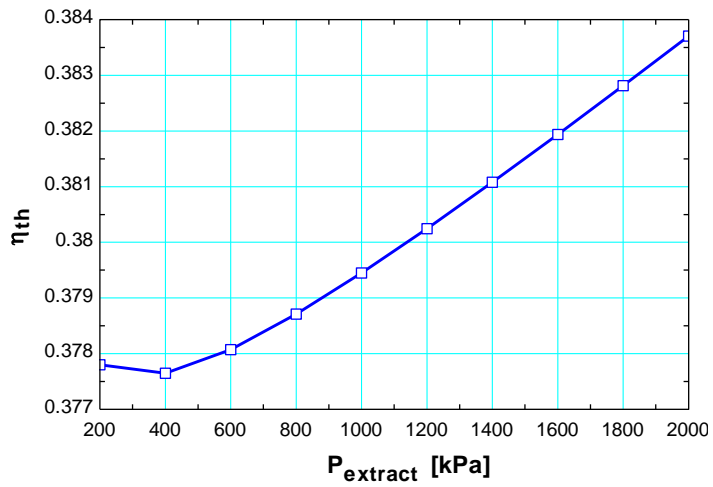

10-74E A cogeneration plant is to generate power while meeting the process steam requirements for a certain industrial application. The net power produced, the rate of process heat supply, and the utilization factor of this plant are to be determined.

Assumptions 1 Steady operating conditions exist. 2 Kinetic and potential energy changes are negligible.

Analysis (a) From the steam tables (Tables A-4E, A-5E, and A-6E),

$$h_1 \cong h_f @ 240^\circ\text{F} = 208.49 \text{ Btu/lbm}$$

$$h_2 \cong h_1$$

$$P_3 = 600 \text{ psia} \left. \vphantom{P_3} \right\} h_3 = 1321.3 \text{ Btu/lbm}$$

$$T_3 = 650^\circ\text{F} \left. \vphantom{T_3} \right\} s_3 = s_5 = s_7 = 1.5614 \text{ Btu/lbm} \cdot \text{R}$$

$$h_3 = h_4 = h_5 = h_6$$

$$P_7 = 120 \text{ psia} \left. \vphantom{P_7} \right\} h_7 = 1169.2 \text{ Btu/lbm}$$

$$s_7 = s_3$$

$$\begin{aligned} \dot{W}_{\text{net}} &= \dot{m}_5 (h_5 - h_7) \\ &= (2/3 \times 32 \text{ lbm/s})(1321.3 - 1169.2) \text{ Btu/lbm} \\ &= 3244 \text{ Btu/s} = \mathbf{3422 \text{ kW}} \end{aligned}$$

$$\begin{aligned} (b) \quad \dot{Q}_{\text{process}} &= \sum \dot{m}_i h_i - \sum \dot{m}_e h_e \\ &= \dot{m}_6 h_6 + \dot{m}_7 h_7 - \dot{m}_1 h_1 \\ &= (1/3 \times 32)(1321.3) + (2/3 \times 32)(1169.2) - (32)(208.49) \\ &= \mathbf{32,365 \text{ Btu/s}} \end{aligned}$$

$$(c) \quad \varepsilon_u = \mathbf{1} \text{ since all the energy is utilized.}$$

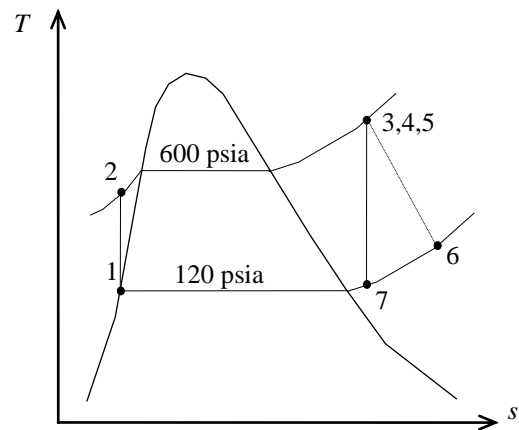
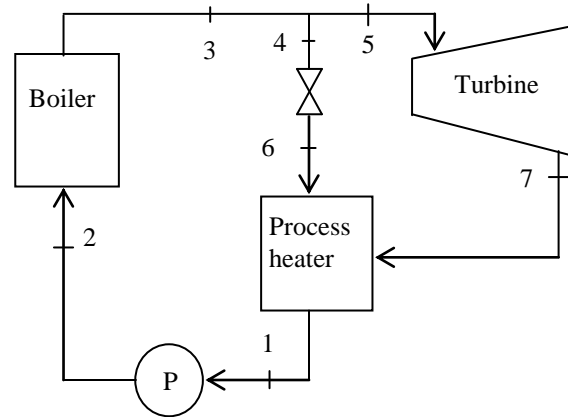

Combined Gas-Vapor Power Cycles

10-75C The energy source of the steam is the waste energy of the exhausted combustion gases.

10-76C Because the combined gas-steam cycle takes advantage of the desirable characteristics of the gas cycle at high temperature, and those of steam cycle at low temperature, and combines them. The result is a cycle that is more efficient than either cycle executed operated alone.

10-77 A combined gas-steam power cycle is considered. The topping cycle is a gas-turbine cycle and the bottoming cycle is a simple ideal Rankine cycle. The mass flow rate of the steam, the net power output, and the thermal efficiency of the combined cycle are to be determined.

Assumptions 1 Steady operating conditions exist. 2 Kinetic and potential energy changes are negligible. 3 Air is an ideal gas with constant specific heats.

Properties The properties of air at room temperature are $c_p = 1.005 \text{ kJ/kg}\cdot\text{K}$ and $k = 1.4$ (Table A-2).

Analysis (a) The analysis of gas cycle yields

$$T_6 = T_5 \left(\frac{P_6}{P_5} \right)^{(k-1)/k} = (300 \text{ K})(16)^{0.4/1.4} = 662.5 \text{ K}$$

$$\dot{Q}_{\text{in}} = \dot{m}_{\text{air}}(h_7 - h_6) = \dot{m}_{\text{air}} c_p (T_7 - T_6) \\ = (14 \text{ kg/s})(1.005 \text{ kJ/kg}\cdot\text{K})(1500 - 662.5) \text{ K} = 11,784 \text{ kW}$$

$$\dot{W}_{C,\text{gas}} = \dot{m}_{\text{air}}(h_6 - h_5) = \dot{m}_{\text{air}} c_p (T_6 - T_5) \\ = (14 \text{ kg/s})(1.005 \text{ kJ/kg}\cdot\text{K})(662.5 - 300) \text{ K} = 5100 \text{ kW}$$

$$T_8 = T_7 \left(\frac{P_8}{P_7} \right)^{(k-1)/k} = (1500 \text{ K}) \left(\frac{1}{16} \right)^{0.4/1.4} = 679.3 \text{ K}$$

$$\dot{W}_{T,\text{gas}} = \dot{m}_{\text{air}}(h_7 - h_8) = \dot{m}_{\text{air}} c_p (T_7 - T_8) \\ = (14 \text{ kg/s})(1.005 \text{ kJ/kg}\cdot\text{K})(1500 - 679.3) \text{ K} = 11,547 \text{ kW}$$

$$\dot{W}_{\text{net,gas}} = \dot{W}_{T,\text{gas}} - \dot{W}_{C,\text{gas}} = 11,547 - 5,100 = 6447 \text{ kW}$$

From the steam tables (Tables A-4, A-5, and A-6),

$$h_1 = h_f @ 15 \text{ kPa} = 225.94 \text{ kJ/kg}$$

$$v_1 = v_f @ 15 \text{ kPa} = 0.001014 \text{ m}^3/\text{kg}$$

$$w_{p,\text{lin}} = v_1(P_2 - P_1) = (0.001014 \text{ m}^3/\text{kg})(10,000 - 15 \text{ kPa}) \left(\frac{1 \text{ kJ}}{1 \text{ kPa}\cdot\text{m}^3} \right) = 10.12 \text{ kJ/kg}$$

$$h_2 = h_1 + w_{p,\text{lin}} = 225.94 + 10.13 = 236.06 \text{ kJ/kg}$$

$$\left. \begin{array}{l} P_3 = 10 \text{ MPa} \\ T_3 = 400^\circ\text{C} \end{array} \right\} \begin{array}{l} h_3 = 3097.0 \text{ kJ/kg} \\ s_3 = 6.2141 \text{ kJ/kg}\cdot\text{K} \end{array}$$

$$\left. \begin{array}{l} P_4 = 15 \text{ kPa} \\ s_4 = s_3 \end{array} \right\} \begin{array}{l} x_4 = \frac{s_4 - s_f}{s_{fg}} = \frac{6.2141 - 0.7549}{7.2522} = 0.7528 \\ h_4 = h_f + x_4 h_{fg} = 225.94 + (0.7528)(2372.3) = 2011.8 \text{ kJ/kg} \end{array}$$

Noting that $\dot{Q} \cong \dot{W} \cong \Delta ke \cong \Delta pe \cong 0$ for the heat exchanger, the steady-flow energy balance equation yields

$$\dot{E}_{\text{in}} - \dot{E}_{\text{out}} = \Delta \dot{E}_{\text{system}} \stackrel{\text{0 (steady)}}{=} 0 \longrightarrow \dot{E}_{\text{in}} = \dot{E}_{\text{out}}$$

$$\sum \dot{m}_i h_i = \sum \dot{m}_e h_e \longrightarrow \dot{m}_s (h_3 - h_2) = \dot{m}_{\text{air}} (h_8 - h_9)$$

$$\dot{m}_s = \frac{h_8 - h_9}{h_3 - h_2} \dot{m}_{\text{air}} = \frac{c_p (T_8 - T_9)}{h_3 - h_2} \dot{m}_{\text{air}} = \frac{(1.005 \text{ kJ/kg}\cdot\text{K})(679.3 - 420) \text{ K}}{(3097.0 - 236.06) \text{ kJ/kg}} (14 \text{ kg/s}) = 1.275 \text{ kg/s}$$

$$(b) \quad \dot{W}_{T,\text{steam}} = \dot{m}_s (h_3 - h_4) = (1.275 \text{ kg/s})(3097.0 - 2011.5) \text{ kJ/kg} = 1384 \text{ kW}$$

$$\dot{W}_{p,\text{steam}} = \dot{m}_s w_p = (1.275 \text{ kg/s})(10.12 \text{ kJ/kg}) = 12.9 \text{ kW}$$

$$\dot{W}_{\text{net,steam}} = \dot{W}_{T,\text{steam}} - \dot{W}_{p,\text{steam}} = 1384 - 12.9 = 1371 \text{ kW}$$

and $\dot{W}_{\text{net}} = \dot{W}_{\text{net,steam}} + \dot{W}_{\text{net,gas}} = 1371 + 6448 = \mathbf{7819 \text{ kW}}$

$$(c) \quad \eta_{\text{th}} = \frac{\dot{W}_{\text{net}}}{\dot{Q}_{\text{in}}} = \frac{7819 \text{ kW}}{11,784 \text{ kW}} = \mathbf{66.4\%}$$

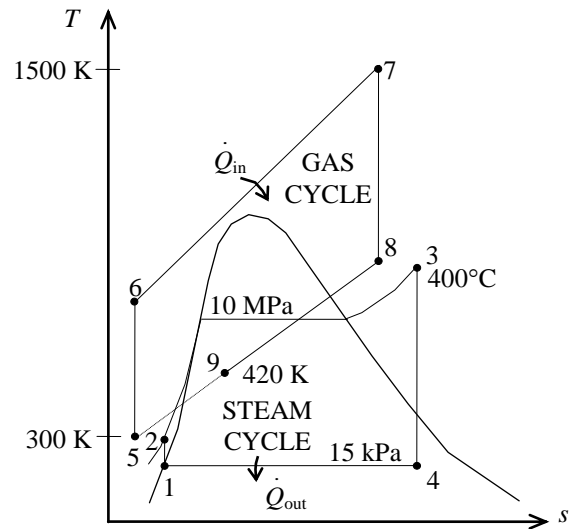



10-78 A 450-MW combined gas-steam power plant is considered. The topping cycle is a gas-turbine cycle and the bottoming cycle is an ideal Rankine cycle with an open feedwater heater. The mass flow rate of air to steam, the required rate of heat input in the combustion chamber, and the thermal efficiency of the combined cycle are to be determined.

Assumptions 1 Steady operating conditions exist. 2 Kinetic and potential energy changes are negligible. 3 Air is an ideal gas with variable specific heats.

Analysis (a) The analysis of gas cycle yields (Table A-17)

$$T_8 = 300 \text{ K} \longrightarrow h_8 = 300.19 \text{ kJ/kg}$$

$$P_{r_8} = 1.386$$

$$P_{r_9} = \frac{P_9}{P_8} P_{r_8} = (14)(1.386) = 19.40 \longrightarrow h_9 = 635.5 \text{ kJ/kg}$$

$$T_{10} = 1400 \text{ K} \longrightarrow h_{10} = 1515.42 \text{ kJ/kg}$$

$$P_{r_{10}} = 450.5$$

$$P_{r_{11}} = \frac{P_{11}}{P_{10}} P_{r_{10}} = \left(\frac{1}{14}\right)(450.5) = 32.18 \longrightarrow h_{11} = 735.8 \text{ kJ/kg}$$

$$T_{12} = 460 \text{ K} \longrightarrow h_{12} = 462.02 \text{ kJ/kg}$$

From the steam tables (Tables A-4, A-5, A-6),

$$h_1 = h_f @ 20 \text{ kPa} = 251.42 \text{ kJ/kg}$$

$$\nu_1 = \nu_f @ 20 \text{ kPa} = 0.001017 \text{ m}^3/\text{kg}$$

$$w_{pI, \text{in}} = \nu_1 (P_2 - P_1)$$

$$= (0.001017 \text{ m}^3/\text{kg})(600 - 20 \text{ kPa}) \left(\frac{1 \text{ kJ}}{1 \text{ kPa} \cdot \text{m}^3} \right)$$

$$= 0.59 \text{ kJ/kg}$$

$$h_2 = h_1 + w_{pI, \text{in}} = 251.42 + 0.59 = 252.01 \text{ kJ/kg}$$

$$h_3 = h_f @ 0.6 \text{ MPa} = 670.38 \text{ kJ/kg}$$

$$\nu_3 = \nu_f @ 0.6 \text{ MPa} = 0.001101 \text{ m}^3/\text{kg}$$

$$w_{pII, \text{in}} = \nu_3 (P_4 - P_3)$$

$$= (0.001101 \text{ m}^3/\text{kg})(8,000 - 600 \text{ kPa}) \left(\frac{1 \text{ kJ}}{1 \text{ kPa} \cdot \text{m}^3} \right)$$

$$= 8.15 \text{ kJ/kg}$$

$$h_4 = h_3 + w_{pII, \text{in}} = 670.38 + 8.15 = 678.53 \text{ kJ/kg}$$

$$\left. \begin{array}{l} P_5 = 8 \text{ MPa} \\ T_5 = 400^\circ\text{C} \end{array} \right\} \begin{array}{l} h_5 = 3139.4 \text{ kJ/kg} \\ s_5 = 6.3658 \text{ kJ/kg} \cdot \text{K} \end{array}$$

$$\left. \begin{array}{l} P_6 = 0.6 \text{ MPa} \\ s_6 = s_5 \end{array} \right\} \begin{array}{l} x_6 = \frac{s_6 - s_f}{s_{fg}} = \frac{6.3658 - 1.9308}{4.8285} = 0.9185 \\ h_6 = h_f + x_6 h_{fg} = 670.38 + (0.9185)(2085.8) = 2586.1 \text{ kJ/kg} \end{array}$$

$$\left. \begin{array}{l} P_7 = 20 \text{ kPa} \\ s_7 = s_5 \end{array} \right\} \begin{array}{l} x_7 = \frac{s_7 - s_f}{s_{fg}} = \frac{6.3658 - 0.8320}{7.0752} = 0.7821 \\ h_7 = h_f + x_7 h_{fg} = 251.42 + (0.7821)(2357.5) = 2095.2 \text{ kJ/kg} \end{array}$$

Noting that $\dot{Q} \cong \dot{W} \cong \Delta ke \cong \Delta pe \cong 0$ for the heat exchanger, the steady-flow energy balance equation yields

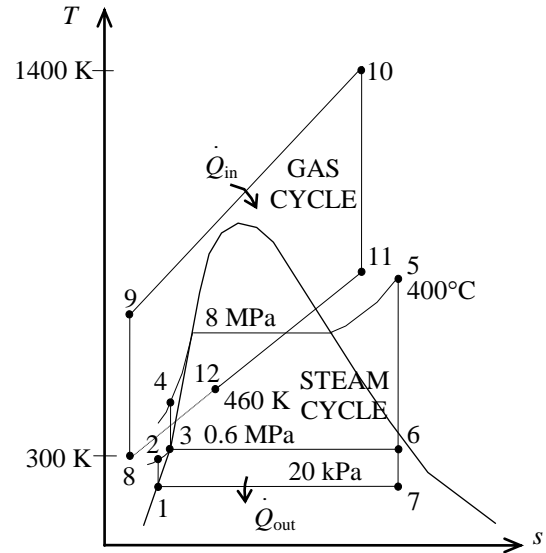

$$\begin{aligned}\dot{E}_{\text{in}} - \dot{E}_{\text{out}} &= \Delta \dot{E}_{\text{system}} \stackrel{\phi^0(\text{steady})}{=} 0 \\ \dot{E}_{\text{in}} &= \dot{E}_{\text{out}} \\ \sum \dot{m}_i h_i &= \sum \dot{m}_e h_e \longrightarrow \dot{m}_s (h_5 - h_4) = \dot{m}_{\text{air}} (h_{11} - h_{12}) \\ \frac{\dot{m}_{\text{air}}}{\dot{m}_s} &= \frac{h_5 - h_4}{h_{11} - h_{12}} = \frac{3139.4 - 678.53}{735.80 - 462.02} = \mathbf{8.99 \text{ kg air / kg steam}}\end{aligned}$$

(b) Noting that $\dot{Q} \cong \dot{W} \cong \Delta ke \cong \Delta pe \cong 0$ for the open FWH, the steady-flow energy balance equation yields

$$\begin{aligned}\dot{E}_{\text{in}} - \dot{E}_{\text{out}} &= \Delta \dot{E}_{\text{system}} \stackrel{\phi^0(\text{steady})}{=} 0 \\ \dot{E}_{\text{in}} &= \dot{E}_{\text{out}} \\ \sum \dot{m}_i h_i &= \sum \dot{m}_e h_e \longrightarrow \dot{m}_2 h_2 + \dot{m}_6 h_6 = \dot{m}_3 h_3 \longrightarrow y h_6 + (1 - y) h_2 = (1) h_3\end{aligned}$$

Thus,

$$\begin{aligned}y &= \frac{h_3 - h_2}{h_6 - h_2} = \frac{670.38 - 252.01}{2586.1 - 252.01} = 0.1792 \quad (\text{the fraction of steam extracted}) \\ w_T &= h_5 - h_6 + (1 - y)(h_6 - h_7) \\ &= 3139.4 - 2586.1 + (1 - 0.1792)(2586.1 - 2095.2) = 956.23 \text{ kJ/kg} \\ w_{\text{net,steam}} &= w_T - w_{p,\text{in}} = w_T - (1 - y)w_{p,I} - w_{p,II} \\ &= 956.23 - (1 - 0.1792)(0.59) - 8.15 = 948.56 \text{ kJ/kg} \\ w_{\text{net,gas}} &= w_T - w_{C,\text{in}} = (h_{10} - h_{11}) - (h_9 - h_8) \\ &= 1515.42 - 735.8 - (635.5 - 300.19) = 444.3 \text{ kJ/kg}\end{aligned}$$

The net work output per unit mass of gas is

$$\begin{aligned}w_{\text{net}} &= w_{\text{net,gas}} + \frac{1}{8.99} w_{\text{net,steam}} = 444.3 + \frac{1}{8.99}(948.56) = 549.8 \text{ kJ/kg} \\ \dot{m}_{\text{air}} &= \frac{\dot{W}_{\text{net}}}{w_{\text{net}}} = \frac{450,000 \text{ kJ/s}}{549.7 \text{ kJ/kg}} = 818.7 \text{ kg/s}\end{aligned}$$

and

$$\dot{Q}_{\text{in}} = \dot{m}_{\text{air}} (h_{10} - h_9) = (818.5 \text{ kg/s})(1515.42 - 635.5) \text{ kJ/kg} = \mathbf{720,215 \text{ kW}}$$

$$(c) \quad \eta_{th} = \frac{\dot{W}_{\text{net}}}{\dot{Q}_{\text{in}}} = \frac{450,000 \text{ kW}}{720,215 \text{ kW}} = \mathbf{62.5\%}$$



10-79 Problem 10-78 is reconsidered. The effect of the gas cycle pressure ratio on the ratio of gas flow rate to steam flow rate and cycle thermal efficiency is to be investigated.

Analysis The problem is solved using EES, and the solution is given below.

"Input data"

T[8] = 300 [K] "Gas compressor inlet"
 P[8] = 14.7 [kPa] "Assumed air inlet pressure"
 "Pratio = 14" "Pressure ratio for gas compressor"
 T[10] = 1400 [K] "Gas turbine inlet"
 T[12] = 460 [K] "Gas exit temperature from Gas-to-steam heat exchanger "
 P[12] = P[8] "Assumed air exit pressure"
 W_dot_net=450 [MW]
 Eta_comp = 1.0
 Eta_gas_turb = 1.0
 Eta_pump = 1.0
 Eta_steam_turb = 1.0
 P[5] = 8000 [kPa] "Steam turbine inlet"
 T[5] =(400+273) "[K]" "Steam turbine inlet"
 P[6] = 600 [kPa] "Extraction pressure for steam open feedwater heater"
 P[7] = 20 [kPa] "Steam condenser pressure"

"GAS POWER CYCLE ANALYSIS"

"Gas Compressor analysis"

s[8]=ENTROPY(Air,T=T[8],P=P[8])
 ss9=s[8] "For the ideal case the entropies are constant across the compressor"
 P[9] = Pratio*P[8]
 Ts9=temperature(Air,s=ss9,P=P[9])"Ts9 is the isentropic value of T[9] at compressor exit"
 Eta_comp = w_gas_comp_isen/w_gas_comp "compressor adiabatic efficiency, w_comp > w_comp_isen"
 h[8] + w_gas_comp_isen =hs9"SSSF conservation of energy for the isentropic compressor, assuming: adiabatic, ke=pe=0 per unit gas mass flow rate in kg/s"
 h[8]=ENTHALPY(Air,T=T[8])
 hs9=ENTHALPY(Air,T=Ts9)
 h[8] + w_gas_comp = h[9]"SSSF conservation of energy for the actual compressor, assuming: adiabatic, ke=pe=0"
 T[9]=temperature(Air,h=h[9])
 s[9]=ENTROPY(Air,T=T[9],P=P[9])

"Gas Cycle External heat exchanger analysis"

h[9] + q_in = h[10]"SSSF conservation of energy for the external heat exchanger, assuming W=0, ke=pe=0"
 h[10]=ENTHALPY(Air,T=T[10])
 P[10]=P[9] "Assume process 9-10 is SSSF constant pressure"
 Q_dot_in"MW"*1000"kW/MW"=m_dot_gas*q_in

"Gas Turbine analysis"

s[10]=ENTROPY(Air,T=T[10],P=P[10])
 ss11=s[10] "For the ideal case the entropies are constant across the turbine"
 P[11] = P[10] /Pratio
 Ts11=temperature(Air,s=ss11,P=P[11])"Ts11 is the isentropic value of T[11] at gas turbine exit"
 Eta_gas_turb = w_gas_turb /w_gas_turb_isen "gas turbine adiabatic efficiency, w_gas_turb_isen > w_gas_turb"
 h[10] = w_gas_turb_isen + hs11"SSSF conservation of energy for the isentropic gas turbine, assuming: adiabatic, ke=pe=0"
 hs11=ENTHALPY(Air,T=Ts11)
 h[10] = w_gas_turb + h[11]"SSSF conservation of energy for the actual gas turbine, assuming: adiabatic, ke=pe=0"
 T[11]=temperature(Air,h=h[11])
 s[11]=ENTROPY(Air,T=T[11],P=P[11])

"Gas-to-Steam Heat Exchanger"

"SSSF conservation of energy for the gas-to-steam heat exchanger, assuming: adiabatic, $W=0$, $ke=pe=0$ "

$$m_{\text{dot_gas}}*h[11] + m_{\text{dot_steam}}*h[4] = m_{\text{dot_gas}}*h[12] + m_{\text{dot_steam}}*h[5]$$

$$h[12]=\text{ENTHALPY}(\text{Air}, T=T[12])$$

$$s[12]=\text{ENTROPY}(\text{Air}, T=T[12], P=P[12])$$

"STEAM CYCLE ANALYSIS"

"Steam Condenser exit pump or Pump 1 analysis"

Fluid\$='Steam_IAPWS'

$$P[1] = P[7]$$

$$P[2]=P[6]$$

$$h[1]=\text{enthalpy}(\text{Fluid}, P=P[1], x=0) \quad \{\text{Saturated liquid}\}$$

$$v1=\text{volume}(\text{Fluid}, P=P[1], x=0)$$

$$s[1]=\text{entropy}(\text{Fluid}, P=P[1], x=0)$$

$$T[1]=\text{temperature}(\text{Fluid}, P=P[1], x=0)$$

$$w_{\text{pump1_s}}=v1*(P[2]-P[1]) \quad \text{"SSSF isentropic pump work assuming constant specific volume"}$$

$$w_{\text{pump1}}=w_{\text{pump1_s}}/\text{Eta_pump} \quad \text{"Definition of pump efficiency"}$$

$$h[1]+w_{\text{pump1}}=h[2] \quad \text{"Steady-flow conservation of energy"}$$

$$s[2]=\text{entropy}(\text{Fluid}, P=P[2], h=h[2])$$

$$T[2]=\text{temperature}(\text{Fluid}, P=P[2], h=h[2])$$

"Open Feedwater Heater analysis"

$$y*h[6] + (1-y)*h[2] = 1*h[3] \quad \text{"Steady-flow conservation of energy"}$$

$$P[3]=P[6]$$

$$h[3]=\text{enthalpy}(\text{Fluid}, P=P[3], x=0) \quad \text{"Condensate leaves heater as sat. liquid at P[3]"}$$

$$T[3]=\text{temperature}(\text{Fluid}, P=P[3], x=0)$$

$$s[3]=\text{entropy}(\text{Fluid}, P=P[3], x=0)$$

"Boiler condensate pump or Pump 2 analysis"

$$P[4] = P[5]$$

$$v3=\text{volume}(\text{Fluid}, P=P[3], x=0)$$

$$w_{\text{pump2_s}}=v3*(P[4]-P[3]) \quad \text{"SSSF isentropic pump work assuming constant specific volume"}$$

$$w_{\text{pump2}}=w_{\text{pump2_s}}/\text{Eta_pump} \quad \text{"Definition of pump efficiency"}$$

$$h[3]+w_{\text{pump2}}=h[4] \quad \text{"Steady-flow conservation of energy"}$$

$$s[4]=\text{entropy}(\text{Fluid}, P=P[4], h=h[4])$$

$$T[4]=\text{temperature}(\text{Fluid}, P=P[4], h=h[4])$$

$$w_{\text{steam_pumps}} = (1-y)*w_{\text{pump1}} + w_{\text{pump2}} \quad \text{"Total steam pump work input/ mass steam"}$$

"Steam Turbine analysis"

$$h[5]=\text{enthalpy}(\text{Fluid}, T=T[5], P=P[5])$$

$$s[5]=\text{entropy}(\text{Fluid}, P=P[5], T=T[5])$$

$$ss6=s[5]$$

$$hs6=\text{enthalpy}(\text{Fluid}, s=ss6, P=P[6])$$

$$Ts6=\text{temperature}(\text{Fluid}, s=ss6, P=P[6])$$

$$h[6]=h[5]-\text{Eta_steam_turb}*(h[5]-hs6) \quad \text{"Definition of steam turbine efficiency"}$$

$$T[6]=\text{temperature}(\text{Fluid}, P=P[6], h=h[6])$$

$$s[6]=\text{entropy}(\text{Fluid}, P=P[6], h=h[6])$$

$$ss7=s[5]$$

$$hs7=\text{enthalpy}(\text{Fluid}, s=ss7, P=P[7])$$

$$Ts7=\text{temperature}(\text{Fluid}, s=ss7, P=P[7])$$

$$h[7]=h[5]-\text{Eta_steam_turb}*(h[5]-hs7) \quad \text{"Definition of steam turbine efficiency"}$$

$$T[7]=\text{temperature}(\text{Fluid}, P=P[7], h=h[7])$$

$$s[7]=\text{entropy}(\text{Fluid}, P=P[7], h=h[7])$$

"SSSF conservation of energy for the steam turbine: adiabatic, neglect ke and pe"

$$h[5] = w_{\text{steam_turb}} + y*h[6] + (1-y)*h[7]$$

"Steam Condenser analysis"

$$(1-y)*h[7]=q_{\text{out}}+(1-y)*h[1] \quad \text{"SSSF conservation of energy for the Condenser per unit mass"}$$

$$Q_{\text{dot_out}}*\text{Convert}(\text{MW}, \text{kW})=m_{\text{dot_steam}}*q_{\text{out}}$$

"Cycle Statistics"

$$\text{MassRatio_gastosteam} = m_{\text{dot_gas}}/m_{\text{dot_steam}}$$

$$W_{\text{dot_net}}*\text{Convert}(\text{MW}, \text{kW})=m_{\text{dot_gas}}*(w_{\text{gas_turb}}-w_{\text{gas_comp}})+ m_{\text{dot_steam}}*(w_{\text{steam_turb}} - w_{\text{steam_pumps}}) \quad \text{"definition of the net cycle work"}$$

$$\text{Eta_th}=W_{\text{dot_net}}/Q_{\text{dot_in}}*\text{Convert}(\text{, \%}) \quad \text{"Cycle thermal efficiency, in percent"}$$

$$Bwr = (m_{\dot{g}} w_{g,comp} + m_{\dot{s}} w_{s,pumps}) / (m_{\dot{g}} w_{g,turb} + m_{\dot{s}} w_{s,turb})$$
 "Back work ratio"

$$W_{\dot{net},s} = m_{\dot{s}} (w_{s,turb} - w_{s,pumps})$$

$$W_{\dot{net},g} = m_{\dot{g}} (w_{g,turb} - w_{g,comp})$$

$$NetWorkRatio_{gastosteam} = W_{\dot{net},g} / W_{\dot{net},s}$$

Pratio	MassRatio gastosteam	W_{netgas} [kW]	$W_{netsteam}$ [kW]	η_{th} [%]	NetWorkRatio gastosteam
10	7.108	342944	107056	59.92	3.203
11	7.574	349014	100986	60.65	3.456
12	8.043	354353	95647	61.29	3.705
13	8.519	359110	90890	61.86	3.951
14	9.001	363394	86606	62.37	4.196
15	9.492	367285	82715	62.83	4.44
16	9.993	370849	79151	63.24	4.685
17	10.51	374135	75865	63.62	4.932
18	11.03	377182	72818	63.97	5.18
19	11.57	380024	69976	64.28	5.431
20	12.12	382687	67313	64.57	5.685

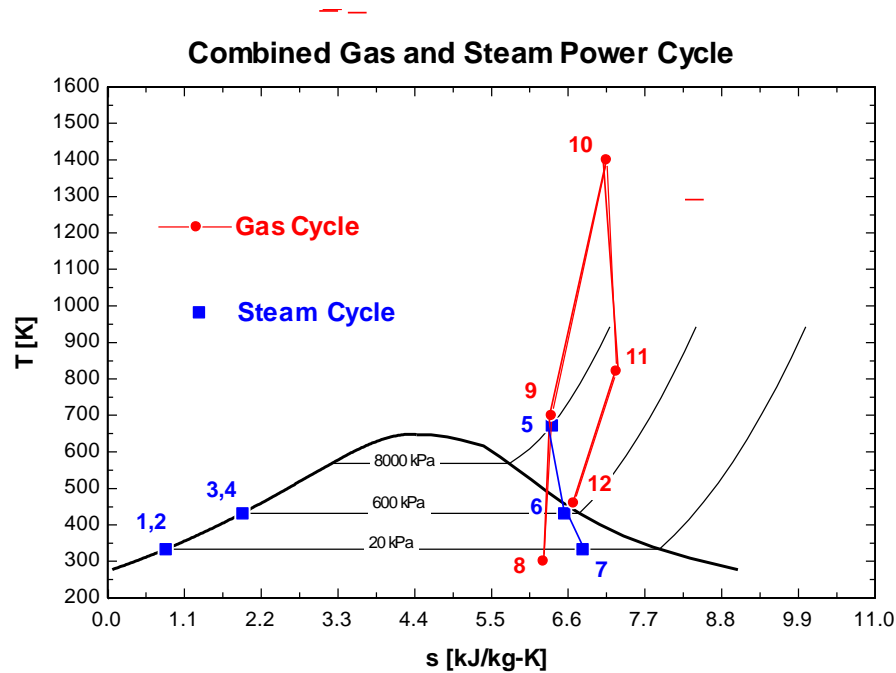

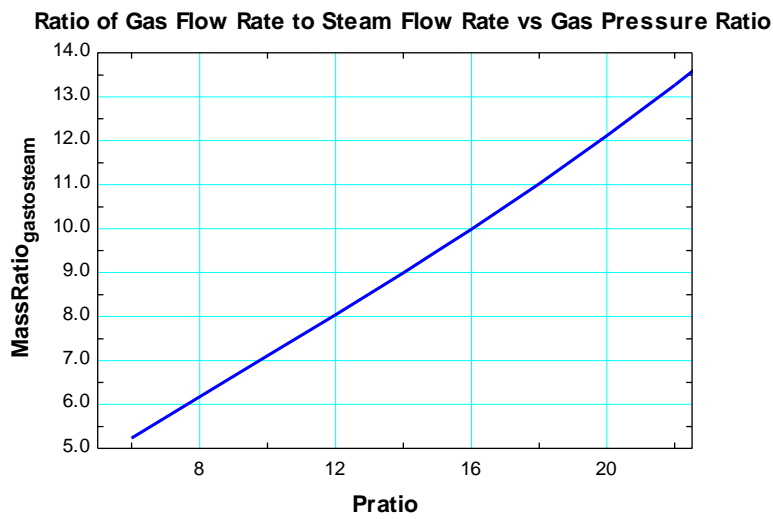
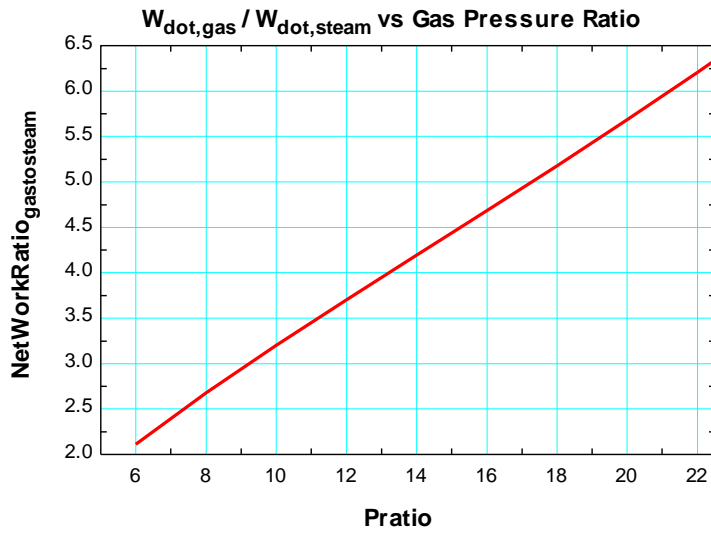
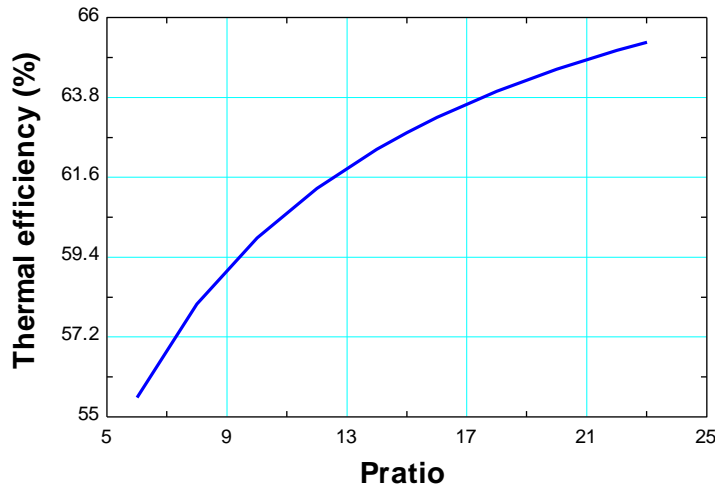

10-80 A 450-MW combined gas-steam power plant is considered. The topping cycle is a gas-turbine cycle and the bottoming cycle is a nonideal Rankine cycle with an open feedwater heater. The mass flow rate of air to steam, the required rate of heat input in the combustion chamber, and the thermal efficiency of the combined cycle are to be determined.

Assumptions 1 Steady operating conditions exist. 2 Kinetic and potential energy changes are negligible. 3 Air is an ideal gas with variable specific heats.

Analysis (a) Using the properties of air from Table A-17, the analysis of gas cycle yields

$$T_8 = 300 \text{ K} \longrightarrow h_8 = 300.19 \text{ kJ/kg}$$

$$P_{r_8} = 1.386$$

$$P_{r_9} = \frac{P_9}{P_8} P_{r_8} = (14)(1.386) = 19.40 \longrightarrow h_{9s} = 635.5 \text{ kJ/kg}$$

$$\eta_C = \frac{h_{9s} - h_8}{h_9 - h_8} \longrightarrow h_9 = h_8 + (h_{9s} - h_8)/\eta_C$$

$$= 300.19 + (635.5 - 300.19)/(0.82)$$

$$= 709.1 \text{ kJ/kg}$$

$$T_{10} = 1400 \text{ K} \longrightarrow h_{10} = 1515.42 \text{ kJ/kg}$$

$$P_{r_{10}} = 450.5$$

$$P_{r_{11}} = \frac{P_{11}}{P_{10}} P_{r_{10}} = \left(\frac{1}{14}\right)(450.5) = 32.18 \longrightarrow h_{11s} = 735.8 \text{ kJ/kg}$$

$$\eta_T = \frac{h_{10} - h_{11}}{h_{10} - h_{11s}} \longrightarrow h_{11} = h_{10} - \eta_T(h_{10} - h_{11s})$$

$$= 1515.42 - (0.86)(1515.42 - 735.8)$$

$$= 844.95 \text{ kJ/kg}$$

$$T_{12} = 460 \text{ K} \longrightarrow h_{12} = 462.02 \text{ kJ/kg}$$

From the steam tables (Tables A-4, A-5, and A-6),

$$h_1 = h_f @ 20 \text{ kPa} = 251.42 \text{ kJ/kg}$$

$$\nu_1 = \nu_f @ 20 \text{ kPa} = 0.001017 \text{ m}^3/\text{kg}$$

$$w_{pI, \text{in}} = \nu_1(P_2 - P_1)$$

$$= (0.001017 \text{ m}^3/\text{kg})(600 - 20 \text{ kPa}) \left(\frac{1 \text{ kJ}}{1 \text{ kPa} \cdot \text{m}^3}\right)$$

$$= 0.59 \text{ kJ/kg}$$

$$h_2 = h_1 + w_{pI, \text{in}} = 251.42 + 0.59 = 252.01 \text{ kJ/kg}$$

$$h_3 = h_f @ 0.6 \text{ MPa} = 670.38 \text{ kJ/kg}$$

$$\nu_3 = \nu_f @ 0.6 \text{ MPa} = 0.001101 \text{ m}^3/\text{kg}$$

$$w_{pII, \text{in}} = \nu_3(P_4 - P_3)$$

$$= (0.001101 \text{ m}^3/\text{kg})(8,000 - 600 \text{ kPa}) \left(\frac{1 \text{ kJ}}{1 \text{ kPa} \cdot \text{m}^3}\right)$$

$$= 8.15 \text{ kJ/kg}$$

$$h_4 = h_3 + w_{pII, \text{in}} = 670.38 + 8.15 = 678.52 \text{ kJ/kg}$$

$$\left. \begin{array}{l} P_5 = 8 \text{ MPa} \\ T_5 = 400^\circ\text{C} \end{array} \right\} \begin{array}{l} h_5 = 3139.4 \text{ kJ/kg} \\ s_5 = 6.3658 \text{ kJ/kg} \cdot \text{K} \end{array}$$

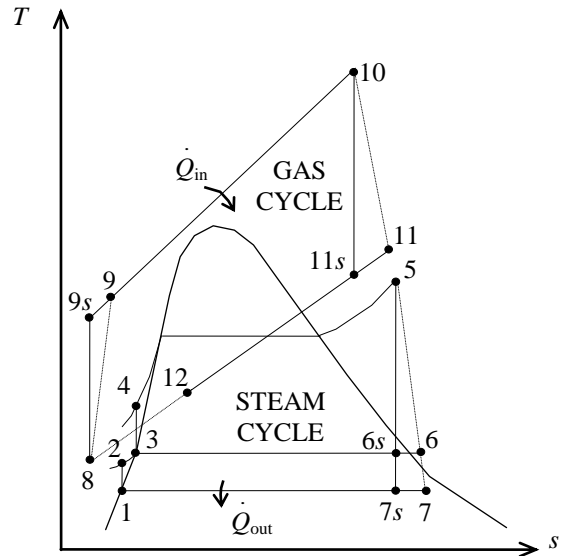

$$P_6 = 0.6 \text{ MPa} \left\{ \begin{array}{l} x_{6s} = \frac{s_{6s} - s_f}{s_{fg}} = \frac{6.3658 - 1.9308}{4.8285} = 0.9184 \\ h_{6s} = h_f + x_{6s} h_{fg} = 670.38 + (0.9184)(2085.8) = 2585.9 \text{ kJ/kg} \end{array} \right.$$

$$\eta_T = \frac{h_5 - h_6}{h_5 - h_{6s}} \longrightarrow h_6 = h_5 - \eta_T (h_5 - h_{6s}) = 3139.4 - (0.86)(3139.4 - 2585.9) = 2663.3 \text{ kJ/kg}$$

$$P_7 = 20 \text{ kPa} \left\{ \begin{array}{l} x_{7s} = \frac{s_7 - s_f}{s_{fg}} = \frac{6.3658 - 0.8320}{7.0752} = 0.7820 \\ h_{7s} = h_f + x_7 h_{fg} = 251.42 + (0.7820)(2357.5) = 2095.1 \text{ kJ/kg} \end{array} \right.$$

$$\eta_T = \frac{h_5 - h_7}{h_5 - h_{7s}} \longrightarrow h_7 = h_5 - \eta_T (h_5 - h_{7s}) = 3139.4 - (0.86)(3139.4 - 2095.1) = 2241.3 \text{ kJ/kg}$$

Noting that $\dot{Q} \cong \dot{W} \cong \Delta ke \cong \Delta pe \cong 0$ for the heat exchanger, the steady-flow energy balance equation yields

$$\begin{aligned} \dot{E}_{\text{in}} - \dot{E}_{\text{out}} &= \Delta \dot{E}_{\text{system}} \overset{\phi^0(\text{steady})}{=} 0 \\ \dot{E}_{\text{in}} &= \dot{E}_{\text{out}} \\ \sum \dot{m}_i h_i &= \sum \dot{m}_e h_e \longrightarrow \dot{m}_s (h_5 - h_4) = \dot{m}_{\text{air}} (h_{11} - h_{12}) \\ \frac{\dot{m}_{\text{air}}}{\dot{m}_s} &= \frac{h_5 - h_4}{h_{11} - h_{12}} = \frac{3139.4 - 678.52}{844.95 - 462.02} = \mathbf{6.425 \text{ kg air / kg steam}} \end{aligned}$$

(b) Noting that $\dot{Q} \cong \dot{W} \cong \Delta ke \cong \Delta pe \cong 0$ for the open FWH, the steady-flow energy balance equation yields

$$\begin{aligned} \dot{E}_{\text{in}} - \dot{E}_{\text{out}} &= \Delta \dot{E}_{\text{system}} \overset{\phi^0(\text{steady})}{=} 0 \rightarrow \dot{E}_{\text{in}} = \dot{E}_{\text{out}} \\ \sum \dot{m}_i h_i &= \sum \dot{m}_e h_e \longrightarrow \dot{m}_2 h_2 + \dot{m}_6 h_6 = \dot{m}_3 h_3 \longrightarrow y h_6 + (1 - y) h_2 = (1) h_3 \end{aligned}$$

Thus,

$$\begin{aligned} y &= \frac{h_3 - h_2}{h_6 - h_2} = \frac{670.38 - 252.01}{2663.3 - 252.01} = 0.1735 \text{ (the fraction of steam extracted)} \\ w_T &= \eta_T [h_5 - h_6 + (1 - y)(h_6 - h_7)] \\ &= (0.86)[3139.4 - 2663.3 + (1 - 0.1735)(2663.3 - 2241.3)] = 824.5 \text{ kJ/kg} \\ w_{\text{net,steam}} &= w_T - w_{p,\text{in}} = w_T - (1 - y)w_{p,I} - w_{p,II} \\ &= 824.5 - (1 - 0.1735)(0.59) - 8.15 = 815.9 \text{ kJ/kg} \\ w_{\text{net,gas}} &= w_T - w_{C,\text{in}} = (h_{10} - h_{11}) - (h_9 - h_8) \\ &= 1515.42 - 844.95 - (709.1 - 300.19) = 261.56 \text{ kJ/kg} \end{aligned}$$

The net work output per unit mass of gas is

$$\begin{aligned} w_{\text{net}} &= w_{\text{net,gas}} + \frac{1}{6.423} w_{\text{net,steam}} = 261.56 + \frac{1}{6.425}(815.9) = 388.55 \text{ kJ/kg} \\ \dot{m}_{\text{air}} &= \frac{\dot{W}_{\text{net}}}{w_{\text{net}}} = \frac{450,000 \text{ kJ/s}}{388.55 \text{ kJ/kg}} = 1158.2 \text{ kg/s} \end{aligned}$$

and $\dot{Q}_{\text{in}} = \dot{m}_{\text{air}} (h_{10} - h_9) = (1158.2 \text{ kg/s})(1515.42 - 709.1) \text{ kJ/kg} = \mathbf{933,850 \text{ kW}}$

$$(c) \quad \eta_{th} = \frac{\dot{W}_{\text{net}}}{\dot{Q}_{\text{in}}} = \frac{450,000 \text{ kW}}{933,850 \text{ kW}} = \mathbf{48.2\%}$$



10-81 Problem 10-80 is reconsidered. The effect of the gas cycle pressure ratio on the ratio of gas flow rate to steam flow rate and cycle thermal efficiency is to be investigated.

Analysis The problem is solved using EES, and the solution is given below.

"Input data"

T[8] = 300 [K]	"Gas compressor inlet"
P[8] = 14.7 [kPa]	"Assumed air inlet pressure"
"Pratio = 14"	"Pressure ratio for gas compressor"
T[10] = 1400 [K]	"Gas turbine inlet"
T[12] = 460 [K]	"Gas exit temperature from Gas-to-steam heat exchanger "
P[12] = P[8]	"Assumed air exit pressure"
W_dot_net=450 [MW]	
Eta_comp = 0.82	
Eta_gas_turb = 0.86	
Eta_pump = 1.0	
Eta_steam_turb = 0.86	
P[5] = 8000 [kPa]	"Steam turbine inlet"
T[5] =(400+273) "K"	"Steam turbine inlet"
P[6] = 600 [kPa]	"Extraction pressure for steam open feedwater heater"
P[7] = 20 [kPa]	"Steam condenser pressure"

"GAS POWER CYCLE ANALYSIS"

"Gas Compressor analysis"

s[8]=ENTROPY(Air,T=T[8],P=P[8])
 ss9=s[8] "For the ideal case the entropies are constant across the compressor"
 P[9] = Pratio*P[8]
 Ts9=temperature(Air,s=ss9,P=P[9])"Ts9 is the isentropic value of T[9] at compressor exit"
 Eta_comp = w_gas_comp_isen/w_gas_comp "compressor adiabatic efficiency, w_comp > w_comp_isen"
 h[8] + w_gas_comp_isen =hs9"SSSF conservation of energy for the isentropic compressor, assuming: adiabatic, ke=pe=0 per unit gas mass flow rate in kg/s"
 h[8]=ENTHALPY(Air,T=T[8])
 hs9=ENTHALPY(Air,T=Ts9)
 h[8] + w_gas_comp = h[9]"SSSF conservation of energy for the actual compressor, assuming: adiabatic, ke=pe=0"
 T[9]=temperature(Air,h=h[9])
 s[9]=ENTROPY(Air,T=T[9],P=P[9])

"Gas Cycle External heat exchanger analysis"

h[9] + q_in = h[10]"SSSF conservation of energy for the external heat exchanger, assuming W=0, ke=pe=0"
 h[10]=ENTHALPY(Air,T=T[10])
 P[10]=P[9] "Assume process 9-10 is SSSF constant pressure"
 Q_dot_in"MW"*1000"kW/MW"=m_dot_gas*q_in

"Gas Turbine analysis"

s[10]=ENTROPY(Air,T=T[10],P=P[10])
 ss11=s[10] "For the ideal case the entropies are constant across the turbine"
 P[11] = P[10] /Pratio
 Ts11=temperature(Air,s=ss11,P=P[11])"Ts11 is the isentropic value of T[11] at gas turbine exit"
 Eta_gas_turb = w_gas_turb /w_gas_turb_isen "gas turbine adiabatic efficiency, w_gas_turb_isen > w_gas_turb"
 h[10] = w_gas_turb_isen + hs11"SSSF conservation of energy for the isentropic gas turbine, assuming: adiabatic, ke=pe=0"
 hs11=ENTHALPY(Air,T=Ts11)
 h[10] = w_gas_turb + h[11]"SSSF conservation of energy for the actual gas turbine, assuming: adiabatic, ke=pe=0"
 T[11]=temperature(Air,h=h[11])
 s[11]=ENTROPY(Air,T=T[11],P=P[11])

"Gas-to-Steam Heat Exchanger"

"SSSF conservation of energy for the gas-to-steam heat exchanger, assuming: adiabatic, $W=0$, $ke=pe=0$ "

$$m_{\text{dot_gas}}*h[11] + m_{\text{dot_steam}}*h[4] = m_{\text{dot_gas}}*h[12] + m_{\text{dot_steam}}*h[5]$$

$$h[12]=\text{ENTHALPY}(\text{Air}, T=T[12])$$

$$s[12]=\text{ENTROPY}(\text{Air}, T=T[12], P=P[12])$$

"STEAM CYCLE ANALYSIS"**"Steam Condenser exit pump or Pump 1 analysis"**

Fluid\$='Steam_IAPWS'

$$P[1] = P[7]$$

$$P[2]=P[6]$$

$$h[1]=\text{enthalpy}(\text{Fluid}, P=P[1], x=0) \quad \{\text{Saturated liquid}\}$$

$$v1=\text{volume}(\text{Fluid}, P=P[1], x=0)$$

$$s[1]=\text{entropy}(\text{Fluid}, P=P[1], x=0)$$

$$T[1]=\text{temperature}(\text{Fluid}, P=P[1], x=0)$$

$$w_{\text{pump1_s}}=v1*(P[2]-P[1]) \quad \text{"SSSF isentropic pump work assuming constant specific volume"}$$

$$w_{\text{pump1}}=w_{\text{pump1_s}}/\text{Eta_pump} \quad \text{"Definition of pump efficiency"}$$

$$h[1]+w_{\text{pump1}}= h[2] \quad \text{"Steady-flow conservation of energy"}$$

$$s[2]=\text{entropy}(\text{Fluid}, P=P[2], h=h[2])$$

$$T[2]=\text{temperature}(\text{Fluid}, P=P[2], h=h[2])$$

"Open Feedwater Heater analysis"

$$y*h[6] + (1-y)*h[2] = 1*h[3] \quad \text{"Steady-flow conservation of energy"}$$

$$P[3]=P[6]$$

$$h[3]=\text{enthalpy}(\text{Fluid}, P=P[3], x=0) \quad \text{"Condensate leaves heater as sat. liquid at P[3]"}$$

$$T[3]=\text{temperature}(\text{Fluid}, P=P[3], x=0)$$

$$s[3]=\text{entropy}(\text{Fluid}, P=P[3], x=0)$$

"Boiler condensate pump or Pump 2 analysis"

$$P[4] = P[5]$$

$$v3=\text{volume}(\text{Fluid}, P=P[3], x=0)$$

$$w_{\text{pump2_s}}=v3*(P[4]-P[3]) \quad \text{"SSSF isentropic pump work assuming constant specific volume"}$$

$$w_{\text{pump2}}=w_{\text{pump2_s}}/\text{Eta_pump} \quad \text{"Definition of pump efficiency"}$$

$$h[3]+w_{\text{pump2}}= h[4] \quad \text{"Steady-flow conservation of energy"}$$

$$s[4]=\text{entropy}(\text{Fluid}, P=P[4], h=h[4])$$

$$T[4]=\text{temperature}(\text{Fluid}, P=P[4], h=h[4])$$

$$w_{\text{steam_pumps}} = (1-y)*w_{\text{pump1}} + w_{\text{pump2}} \quad \text{"Total steam pump work input/ mass steam"}$$

"Steam Turbine analysis"

$$h[5]=\text{enthalpy}(\text{Fluid}, T=T[5], P=P[5])$$

$$s[5]=\text{entropy}(\text{Fluid}, P=P[5], T=T[5])$$

$$ss6=s[5]$$

$$hs6=\text{enthalpy}(\text{Fluid}, s=ss6, P=P[6])$$

$$Ts6=\text{temperature}(\text{Fluid}, s=ss6, P=P[6])$$

$$h[6]=h[5]-\text{Eta_steam_turb}*(h[5]-hs6) \quad \text{"Definition of steam turbine efficiency"}$$

$$T[6]=\text{temperature}(\text{Fluid}, P=P[6], h=h[6])$$

$$s[6]=\text{entropy}(\text{Fluid}, P=P[6], h=h[6])$$

$$ss7=s[5]$$

$$hs7=\text{enthalpy}(\text{Fluid}, s=ss7, P=P[7])$$

$$Ts7=\text{temperature}(\text{Fluid}, s=ss7, P=P[7])$$

$$h[7]=h[5]-\text{Eta_steam_turb}*(h[5]-hs7) \quad \text{"Definition of steam turbine efficiency"}$$

$$T[7]=\text{temperature}(\text{Fluid}, P=P[7], h=h[7])$$

$$s[7]=\text{entropy}(\text{Fluid}, P=P[7], h=h[7])$$

"SSSF conservation of energy for the steam turbine: adiabatic, neglect ke and pe"

$$h[5] = w_{\text{steam_turb}} + y*h[6] + (1-y)*h[7]$$

"Steam Condenser analysis"

$$(1-y)*h[7]=q_{\text{out}}+(1-y)*h[1] \quad \text{"SSSF conservation of energy for the Condenser per unit mass"}$$

$$Q_{\text{dot_out}}*\text{Convert}(\text{MW}, \text{kW})=m_{\text{dot_steam}}*q_{\text{out}}$$

"Cycle Statistics"

$$\text{MassRatio_gastosteam} = m_{\text{dot_gas}}/m_{\text{dot_steam}}$$

$$W_{\text{dot_net}}*\text{Convert}(\text{MW}, \text{kW})=m_{\text{dot_gas}}*(w_{\text{gas_turb}}-w_{\text{gas_comp}})+ m_{\text{dot_steam}}*(w_{\text{steam_turb}} - w_{\text{steam_pumps}}) \quad \text{"definition of the net cycle work"}$$

$$\text{Eta_th}=W_{\text{dot_net}}/Q_{\text{dot_in}}*\text{Convert}(\text{, \%}) \quad \text{"Cycle thermal efficiency, in percent"}$$

$Bwr = (m_{\dot{g}as} w_{gas_comp} + m_{\dot{s}team} w_{steam_pumps}) / (m_{\dot{g}as} w_{gas_turb} + m_{\dot{s}team} w_{steam_turb})$ "Back work ratio"

$W_{\dot{net_steam}} = m_{\dot{s}team} (w_{steam_turb} - w_{steam_pumps})$

$W_{\dot{net_gas}} = m_{\dot{g}as} (w_{gas_turb} - w_{gas_comp})$

$NetWorkRatio_{gastosteam} = W_{\dot{net_gas}} / W_{\dot{net_steam}}$

Pratio	MassRatio gastosteam	W_{netgas} [kW]	$W_{netsteam}$ [kW]	η_{th} [%]	NetWorkRatio gastosteam
6	4.463	262595	187405	45.29	1.401
8	5.024	279178	170822	46.66	1.634
10	5.528	289639	160361	47.42	1.806
12	5.994	296760	153240	47.82	1.937
14	6.433	301809	148191	47.99	2.037
15	6.644	303780	146220	48.01	2.078
16	6.851	305457	144543	47.99	2.113
18	7.253	308093	141907	47.87	2.171
20	7.642	309960	140040	47.64	2.213
22	8.021	311216	138784	47.34	2.242

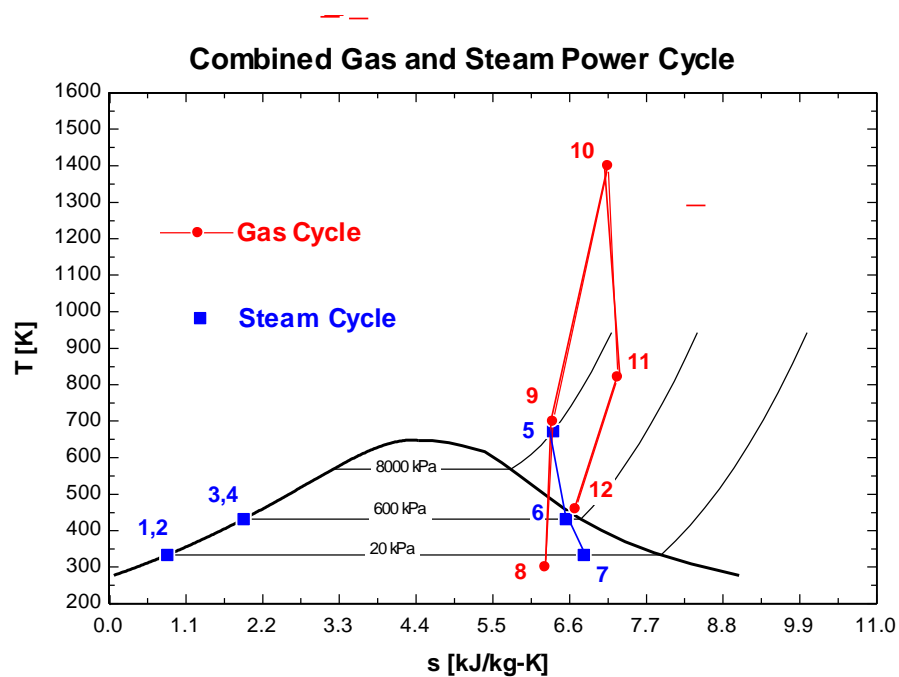

Cycle Thermal Efficiency vs Gas Cycle Pressure Ratio

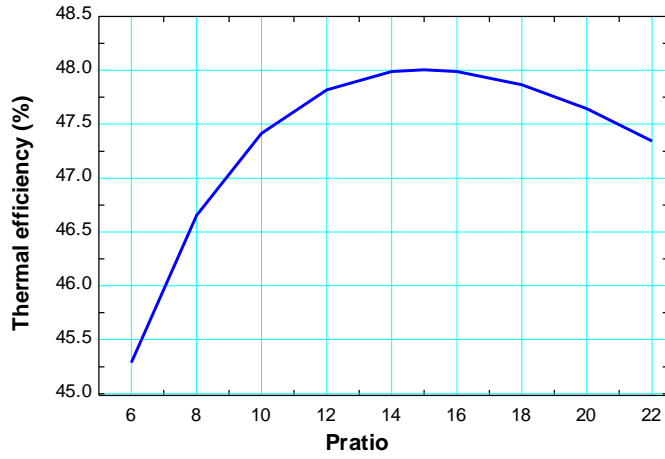

$W_{\dot{g},gas} / W_{\dot{g},steam}$ vs Gas Pressure Ratio

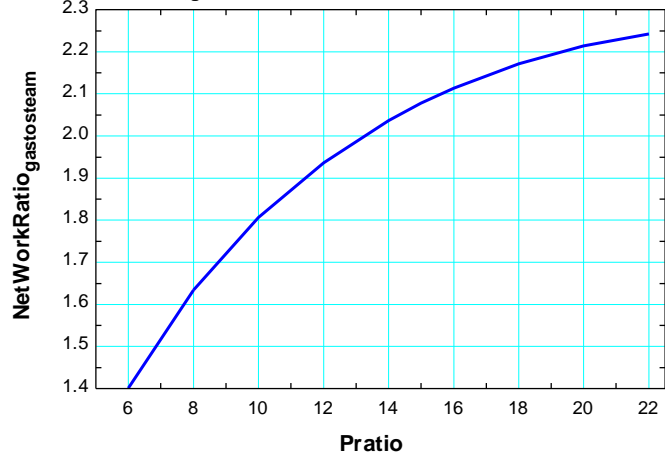

Ratio of Gas Flow Rate to Steam Flow Rate vs Gas Pressure Ratio

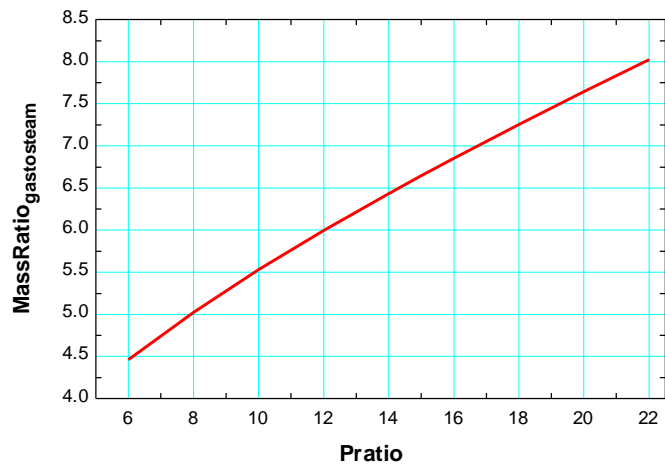

10-82 A 280-MW combined gas-steam power plant is considered. The topping cycle is a gas-turbine cycle and the bottoming cycle is a nonideal Rankine cycle with an open feedwater heater. The mass flow rate of air to steam, the required rate of heat input in the combustion chamber, and the thermal efficiency of the combined cycle are to be determined.

Assumptions 1 Steady operating conditions exist. 2 Kinetic and potential energy changes are negligible. 3 Air is an ideal gas with variable specific heats.

Analysis (a) Using the properties of air from Table A-17, the analysis of gas cycle yields

$$T_8 = 300 \text{ K} \longrightarrow h_8 = 300.19 \text{ kJ/kg} \\ P_{r_8} = 1.386$$

$$P_{r_9} = \frac{P_9}{P_8} P_{r_8} = (11)(1.386) = 15.25 \longrightarrow h_{9s} = 595.84 \text{ kJ/kg}$$

$$\eta_C = \frac{h_{9s} - h_8}{h_9 - h_8} \longrightarrow h_9 = h_8 + (h_{9s} - h_8) / \eta_C \\ = 300.19 + (595.84 - 300.19) / (0.82) \\ = 660.74 \text{ kJ/kg}$$

$$T_{10} = 1100 \text{ K} \longrightarrow h_{10} = 1161.07 \text{ kJ/kg} \\ P_{r_{10}} = 167.1$$

$$P_{r_{11}} = \frac{P_{11}}{P_{10}} P_{r_{10}} = \left(\frac{1}{11}\right)(167.1) = 15.19 \longrightarrow h_{11s} = 595.18 \text{ kJ/kg}$$

$$\eta_T = \frac{h_{10} - h_{11}}{h_{10} - h_{11s}} \longrightarrow h_{11} = h_{10} - \eta_T (h_{10} - h_{11s}) \\ = 1161.07 - (0.86)(1161.07 - 595.18) \\ = 674.40 \text{ kJ/kg}$$

$$T_{12} = 420 \text{ K} \longrightarrow h_{12} = 421.26 \text{ kJ/kg}$$

From the steam tables (Tables A-4, A-5, and A-6),

$$h_1 = h_f @ 10 \text{ kPa} = 191.81 \text{ kJ/kg}$$

$$\nu_1 = \nu_f @ 10 \text{ kPa} = 0.00101 \text{ m}^3/\text{kg}$$

$$w_{pI, \text{in}} = \nu_1 (P_2 - P_1) \\ = (0.00101 \text{ m}^3/\text{kg})(800 - 10 \text{ kPa}) \left(\frac{1 \text{ kJ}}{1 \text{ kPa} \cdot \text{m}^3} \right) \\ = 0.80 \text{ kJ/kg}$$

$$h_2 = h_1 + w_{pI, \text{in}} = 191.81 + 0.80 = 192.60 \text{ kJ/kg}$$

$$h_3 = h_f @ 0.8 \text{ MPa} = 720.87 \text{ kJ/kg}$$

$$\nu_3 = \nu_f @ 0.8 \text{ MPa} = 0.001115 \text{ m}^3/\text{kg}$$

$$w_{pII, \text{in}} = \nu_3 (P_4 - P_3) \\ = (0.001115 \text{ m}^3/\text{kg})(5000 - 800 \text{ kPa}) \left(\frac{1 \text{ kJ}}{1 \text{ kPa} \cdot \text{m}^3} \right) \\ = 4.68 \text{ kJ/kg}$$

$$h_4 = h_3 + w_{pII, \text{in}} = 720.87 + 4.68 = 725.55 \text{ kJ/kg}$$

$$\left. \begin{array}{l} P_5 = 5 \text{ MPa} \\ T_5 = 350^\circ\text{C} \end{array} \right\} \begin{array}{l} h_5 = 3069.3 \text{ kJ/kg} \\ s_5 = 6.4516 \text{ kJ/kg} \cdot \text{K} \end{array}$$

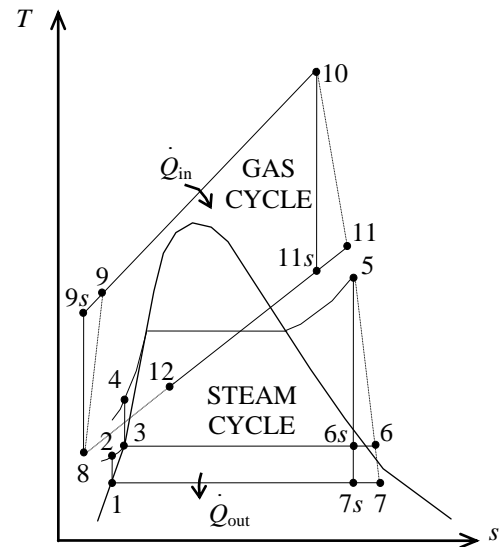

$$P_6 = 0.8 \text{ MPa} \left\{ \begin{array}{l} x_{6s} = \frac{s_{6s} - s_f}{s_{fg}} = \frac{6.4516 - 2.0457}{4.6160} = 0.9545 \\ h_{6s} = h_f + x_{6s} h_{fg} = 720.87 + (0.9545)(2085.8) = 2675.1 \text{ kJ/kg} \end{array} \right.$$

$$\eta_T = \frac{h_5 - h_6}{h_5 - h_{6s}} \longrightarrow h_6 = h_5 - \eta_T (h_5 - h_{6s}) = 3069.3 - (0.86)(3069.3 - 2675.1) = 2730.3 \text{ kJ/kg}$$

$$P_7 = 10 \text{ kPa} \left\{ \begin{array}{l} x_{7s} = \frac{s_7 - s_f}{s_{fg}} = \frac{6.4516 - 0.6492}{7.4996} = 0.7737 \\ h_{7s} = h_f + x_7 h_{fg} = 191.81 + (0.7737)(2392.1) = 2042.5 \text{ kJ/kg} \end{array} \right.$$

$$\eta_T = \frac{h_5 - h_7}{h_5 - h_{7s}} \longrightarrow h_7 = h_5 - \eta_T (h_5 - h_{7s}) = 3069.3 - (0.86)(3069.3 - 2042.5) = 2186.3 \text{ kJ/kg}$$

Noting that $\dot{Q} \cong \dot{W} \cong \Delta ke \cong \Delta pe \cong 0$ for the heat exchanger, the steady-flow energy balance equation yields

$$\begin{aligned} \dot{E}_{\text{in}} - \dot{E}_{\text{out}} &= \Delta \dot{E}_{\text{system}} \stackrel{\text{0(steady)}}{=} 0 \\ \dot{E}_{\text{in}} &= \dot{E}_{\text{out}} \\ \sum \dot{m}_i h_i &= \sum \dot{m}_e h_e \longrightarrow \dot{m}_s (h_5 - h_4) = \dot{m}_{\text{air}} (h_{11} - h_{12}) \\ \frac{\dot{m}_{\text{air}}}{\dot{m}_s} &= \frac{h_5 - h_4}{h_{11} - h_{12}} = \frac{3069.3 - 725.55}{674.40 - 421.26} = \mathbf{9.259 \text{ kg air / kg steam}} \end{aligned}$$

(b) Noting that $\dot{Q} \cong \dot{W} \cong \Delta ke \cong \Delta pe \cong 0$ for the open FWH, the steady-flow energy balance equation yields

$$\begin{aligned} \dot{E}_{\text{in}} - \dot{E}_{\text{out}} &= \Delta \dot{E}_{\text{system}} \stackrel{\text{0(steady)}}{=} 0 \rightarrow \dot{E}_{\text{in}} = \dot{E}_{\text{out}} \\ \sum \dot{m}_i h_i &= \sum \dot{m}_e h_e \longrightarrow \dot{m}_2 h_2 + \dot{m}_6 h_6 = \dot{m}_3 h_3 \longrightarrow y h_6 + (1 - y) h_2 = (1) h_3 \end{aligned}$$

Thus,

$$\begin{aligned} y &= \frac{h_3 - h_2}{h_6 - h_2} = \frac{720.87 - 192.60}{2730.3 - 192.60} = 0.2082 \text{ (the fraction of steam extracted)} \\ w_T &= \eta_T [h_5 - h_6 + (1 - y)(h_6 - h_7)] \\ &= (0.86)[3069.3 - 2730.3 + (1 - 0.2082)(2730.3 - 2186.3)] = 769.8 \text{ kJ/kg} \\ w_{\text{net,steam}} &= w_T - w_{p,\text{in}} = w_T - (1 - y)w_{p,\text{I}} - w_{p,\text{II}} \\ &= 769.8 - (1 - 0.2082)(0.80) - 4.68 = 764.5 \text{ kJ/kg} \\ w_{\text{net,gas}} &= w_T - w_{C,\text{in}} = (h_{10} - h_{11}) - (h_9 - h_8) \\ &= 1161.07 - 674.40 - (660.74 - 300.19) = 126.12 \text{ kJ/kg} \end{aligned}$$

The net work output per unit mass of gas is

$$w_{\text{net}} = w_{\text{net,gas}} + \frac{1}{6.425} w_{\text{net,steam}} = 126.12 + \frac{1}{9.259} (764.5) = 208.69 \text{ kJ/kg}$$

$$\dot{m}_{\text{air}} = \frac{\dot{W}_{\text{net}}}{w_{\text{net}}} = \frac{280,000 \text{ kJ/s}}{208.69 \text{ kJ/kg}} = 1341.7 \text{ kg/s}$$

and $\dot{Q}_{\text{in}} = \dot{m}_{\text{air}} (h_{10} - h_9) = (1341.7 \text{ kg/s})(1161.07 - 660.74) \text{ kJ/kg} = \mathbf{671,300 \text{ kW}}$

(c) $\eta_{\text{th}} = \frac{\dot{W}_{\text{net}}}{\dot{Q}_{\text{in}}} = \frac{280,000 \text{ kW}}{671,300 \text{ kW}} = 0.4171 = \mathbf{41.7\%}$



10-83 Problem 10-82 is reconsidered. The effect of the gas cycle pressure ratio on the ratio of gas flow rate to steam flow rate and cycle thermal efficiency is to be investigated.

Analysis The problem is solved using EES, and the solution is given below.

"Input data"

T[8] = 300 [K] "Gas compressor inlet"
 P[8] = 100 [kPa] "Assumed air inlet pressure"
 "Pratio = 11" "Pressure ratio for gas compressor"
 T[10] = 1100 [K] "Gas turbine inlet"
 T[12] = 420 [K] "Gas exit temperature from Gas-to-steam heat exchanger"
 P[12] = P[8] "Assumed air exit pressure"
 W_dot_net=280 [MW]
 Eta_comp = 0.82
 Eta_gas_turb = 0.86
 Eta_pump = 1.0
 Eta_steam_turb = 0.86
 P[5] = 5000 [kPa] "Steam turbine inlet"
 T[5] =(350+273.15) "K" "Steam turbine inlet"
 P[6] = 800 [kPa] "Extraction pressure for steam open feedwater heater"
 P[7] = 10 [kPa] "Steam condenser pressure"

"GAS POWER CYCLE ANALYSIS"

"Gas Compressor analysis"

s[8]=ENTROPY(Air,T=T[8],P=P[8])
 ss9=s[8] "For the ideal case the entropies are constant across the compressor"
 P[9] = Pratio*P[8]
 Ts9=temperature(Air,s=ss9,P=P[9])"Ts9 is the isentropic value of T[9] at compressor exit"
 Eta_comp = w_gas_comp_isen/w_gas_comp "compressor adiabatic efficiency, w_comp > w_comp_isen"
 h[8] + w_gas_comp_isen =hs9"SSSF conservation of energy for the isentropic compressor, assuming: adiabatic, ke=pe=0 per unit gas mass flow rate in kg/s"
 h[8]=ENTHALPY(Air,T=T[8])
 hs9=ENTHALPY(Air,T=Ts9)
 h[8] + w_gas_comp = h[9]"SSSF conservation of energy for the actual compressor, assuming: adiabatic, ke=pe=0"
 T[9]=temperature(Air,h=h[9])
 s[9]=ENTROPY(Air,T=T[9],P=P[9])

"Gas Cycle External heat exchanger analysis"

h[9] + q_in = h[10]"SSSF conservation of energy for the external heat exchanger, assuming W=0, ke=pe=0"
 h[10]=ENTHALPY(Air,T=T[10])
 P[10]=P[9] "Assume process 9-10 is SSSF constant pressure"
 Q_dot_in"MW"*1000"kW/MW"=m_dot_gas*q_in

"Gas Turbine analysis"

s[10]=ENTROPY(Air,T=T[10],P=P[10])
 ss11=s[10] "For the ideal case the entropies are constant across the turbine"
 P[11] = P[10] /Pratio
 Ts11=temperature(Air,s=ss11,P=P[11])"Ts11 is the isentropic value of T[11] at gas turbine exit"
 Eta_gas_turb = w_gas_turb /w_gas_turb_isen "gas turbine adiabatic efficiency, w_gas_turb_isen > w_gas_turb"
 h[10] = w_gas_turb_isen + hs11"SSSF conservation of energy for the isentropic gas turbine, assuming: adiabatic, ke=pe=0"
 hs11=ENTHALPY(Air,T=Ts11)
 h[10] = w_gas_turb + h[11]"SSSF conservation of energy for the actual gas turbine, assuming: adiabatic, ke=pe=0"
 T[11]=temperature(Air,h=h[11])
 s[11]=ENTROPY(Air,T=T[11],P=P[11])

"Gas-to-Steam Heat Exchanger"

"SSSF conservation of energy for the gas-to-steam heat exchanger, assuming: adiabatic, $W=0$, $ke=pe=0$ "

$$m_{\text{dot_gas}}*h[11] + m_{\text{dot_steam}}*h[4] = m_{\text{dot_gas}}*h[12] + m_{\text{dot_steam}}*h[5]$$

$$h[12]=\text{ENTHALPY}(\text{Air}, T=T[12])$$

$$s[12]=\text{ENTROPY}(\text{Air}, T=T[12], P=P[12])$$

"STEAM CYCLE ANALYSIS"**"Steam Condenser exit pump or Pump 1 analysis"**

Fluid\$='Steam_IAPWS'

$$P[1] = P[7]$$

$$P[2]=P[6]$$

$$h[1]=\text{enthalpy}(\text{Fluid}, P=P[1], x=0) \quad \{\text{Saturated liquid}\}$$

$$v1=\text{volume}(\text{Fluid}, P=P[1], x=0)$$

$$s[1]=\text{entropy}(\text{Fluid}, P=P[1], x=0)$$

$$T[1]=\text{temperature}(\text{Fluid}, P=P[1], x=0)$$

$$w_{\text{pump1_s}}=v1*(P[2]-P[1]) \quad \text{"SSSF isentropic pump work assuming constant specific volume"}$$

$$w_{\text{pump1}}=w_{\text{pump1_s}}/\text{Eta_pump} \quad \text{"Definition of pump efficiency"}$$

$$h[1]+w_{\text{pump1}}= h[2] \quad \text{"Steady-flow conservation of energy"}$$

$$s[2]=\text{entropy}(\text{Fluid}, P=P[2], h=h[2])$$

$$T[2]=\text{temperature}(\text{Fluid}, P=P[2], h=h[2])$$

"Open Feedwater Heater analysis"

$$y*h[6] + (1-y)*h[2] = 1*h[3] \quad \text{"Steady-flow conservation of energy"}$$

$$P[3]=P[6]$$

$$h[3]=\text{enthalpy}(\text{Fluid}, P=P[3], x=0) \quad \text{"Condensate leaves heater as sat. liquid at P[3]"}$$

$$T[3]=\text{temperature}(\text{Fluid}, P=P[3], x=0)$$

$$s[3]=\text{entropy}(\text{Fluid}, P=P[3], x=0)$$

"Boiler condensate pump or Pump 2 analysis"

$$P[4] = P[5]$$

$$v3=\text{volume}(\text{Fluid}, P=P[3], x=0)$$

$$w_{\text{pump2_s}}=v3*(P[4]-P[3]) \quad \text{"SSSF isentropic pump work assuming constant specific volume"}$$

$$w_{\text{pump2}}=w_{\text{pump2_s}}/\text{Eta_pump} \quad \text{"Definition of pump efficiency"}$$

$$h[3]+w_{\text{pump2}}= h[4] \quad \text{"Steady-flow conservation of energy"}$$

$$s[4]=\text{entropy}(\text{Fluid}, P=P[4], h=h[4])$$

$$T[4]=\text{temperature}(\text{Fluid}, P=P[4], h=h[4])$$

$$w_{\text{steam_pumps}} = (1-y)*w_{\text{pump1}} + w_{\text{pump2}} \quad \text{"Total steam pump work input/ mass steam"}$$

"Steam Turbine analysis"

$$h[5]=\text{enthalpy}(\text{Fluid}, T=T[5], P=P[5])$$

$$s[5]=\text{entropy}(\text{Fluid}, P=P[5], T=T[5])$$

$$ss6=s[5]$$

$$hs6=\text{enthalpy}(\text{Fluid}, s=ss6, P=P[6])$$

$$Ts6=\text{temperature}(\text{Fluid}, s=ss6, P=P[6])$$

$$h[6]=h[5]-\text{Eta_steam_turb}*(h[5]-hs6) \quad \text{"Definition of steam turbine efficiency"}$$

$$T[6]=\text{temperature}(\text{Fluid}, P=P[6], h=h[6])$$

$$s[6]=\text{entropy}(\text{Fluid}, P=P[6], h=h[6])$$

$$ss7=s[5]$$

$$hs7=\text{enthalpy}(\text{Fluid}, s=ss7, P=P[7])$$

$$Ts7=\text{temperature}(\text{Fluid}, s=ss7, P=P[7])$$

$$h[7]=h[5]-\text{Eta_steam_turb}*(h[5]-hs7) \quad \text{"Definition of steam turbine efficiency"}$$

$$T[7]=\text{temperature}(\text{Fluid}, P=P[7], h=h[7])$$

$$s[7]=\text{entropy}(\text{Fluid}, P=P[7], h=h[7])$$

"SSSF conservation of energy for the steam turbine: adiabatic, neglect ke and pe"

$$h[5] = w_{\text{steam_turb}} + y*h[6] + (1-y)*h[7]$$

"Steam Condenser analysis"

$$(1-y)*h[7]=q_{\text{out}}+(1-y)*h[1] \quad \text{"SSSF conservation of energy for the Condenser per unit mass"}$$

$$Q_{\text{dot_out}}*\text{Convert}(\text{MW}, \text{kW})=m_{\text{dot_steam}}*q_{\text{out}}$$

"Cycle Statistics"

$$\text{MassRatio_gastosteam} = m_{\text{dot_gas}}/m_{\text{dot_steam}}$$

$$W_{\text{dot_net}}*\text{Convert}(\text{MW}, \text{kW})=m_{\text{dot_gas}}*(w_{\text{gas_turb}}-w_{\text{gas_comp}})+ m_{\text{dot_steam}}*(w_{\text{steam_turb}} - w_{\text{steam_pumps}}) \quad \text{"definition of the net cycle work"}$$

$$\text{Eta_th}=W_{\text{dot_net}}/Q_{\text{dot_in}}*\text{Convert}(\text{, \%}) \quad \text{"Cycle thermal efficiency, in percent"}$$

$Bwr = (m_{dot_gas} * w_{gas_comp} + m_{dot_steam} * w_{steam_pumps}) / (m_{dot_gas} * w_{gas_turb} + m_{dot_steam} * w_{steam_turb})$ "Back work ratio"
 $W_{dot_net_steam} = m_{dot_steam} * (w_{steam_turb} - w_{steam_pumps})$
 $W_{dot_net_gas} = m_{dot_gas} * (w_{gas_turb} - w_{gas_comp})$
 $NetWorkRatio_{gastosteam} = W_{dot_net_gas} / W_{dot_net_steam}$

Pratio	MassRatio _{gastosteam}	η_{th} [%]
10	8.775	42.03
11	9.262	41.67
12	9.743	41.22
13	10.22	40.68
14	10.7	40.08
15	11.17	39.4
16	11.64	38.66
17	12.12	37.86
18	12.59	36.99
19	13.07	36.07
20	13.55	35.08

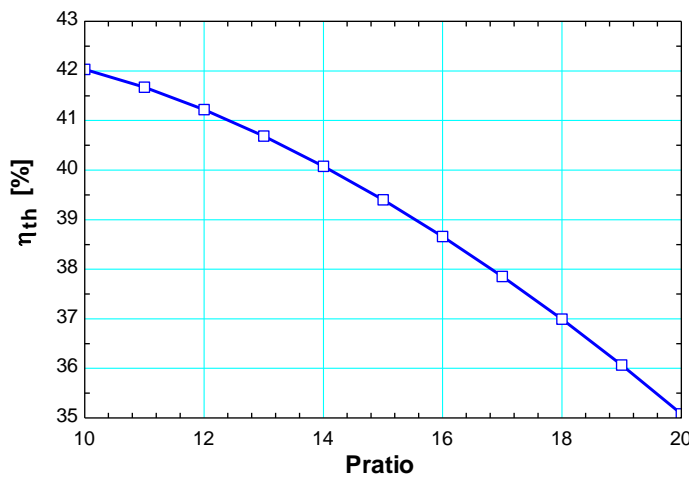
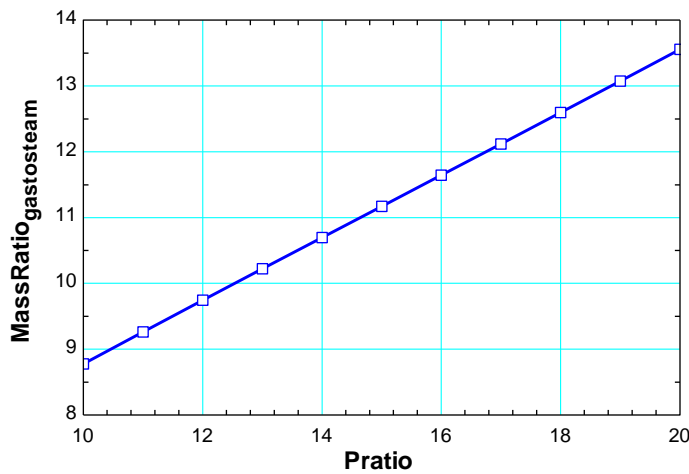
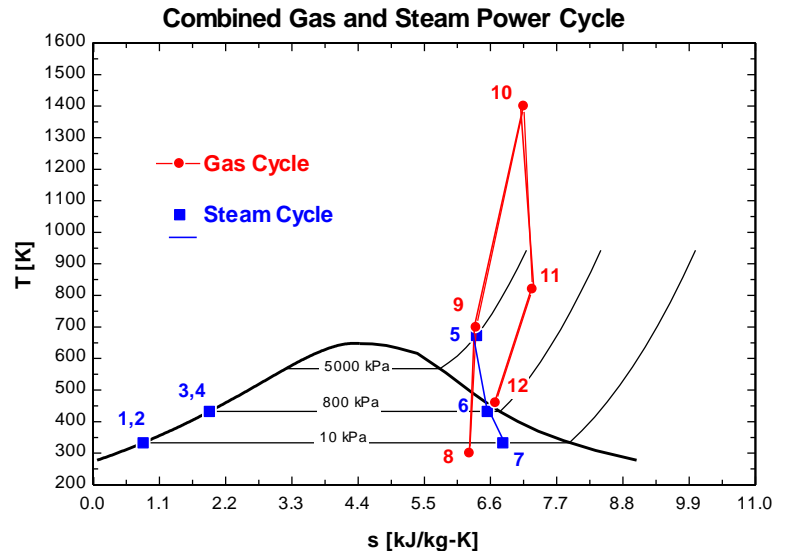

10-84 A combined gas-steam power plant is considered. The topping cycle is a gas-turbine cycle and the bottoming cycle is a nonideal reheat Rankine cycle. The moisture percentage at the exit of the low-pressure turbine, the steam temperature at the inlet of the high-pressure turbine, and the thermal efficiency of the combined cycle are to be determined.

Assumptions 1 Steady operating conditions exist. **2** Kinetic and potential energy changes are negligible. **3** Air is an ideal gas with variable specific heats.

Analysis (a) We obtain the air properties from EES. The analysis of gas cycle is as follows

$$T_7 = 15^\circ\text{C} \longrightarrow h_7 = 288.53 \text{ kJ/kg}$$

$$\left. \begin{array}{l} T_7 = 15^\circ\text{C} \\ P_7 = 100 \text{ kPa} \end{array} \right\} s_7 = 5.6649 \text{ kJ/kg}$$

$$\left. \begin{array}{l} P_8 = 700 \text{ kPa} \\ s_8 = s_7 \end{array} \right\} h_{8s} = 503.70 \text{ kJ/kg}$$

$$\eta_C = \frac{h_{8s} - h_7}{h_8 - h_7} \longrightarrow h_8 = h_7 + (h_{8s} - h_7)/\eta_C \\ = 288.53 + (503.70 - 288.53)/(0.80) \\ = 557.49 \text{ kJ/kg}$$

$$T_9 = 950^\circ\text{C} \longrightarrow h_9 = 1305.2 \text{ kJ/kg}$$

$$\left. \begin{array}{l} T_9 = 950^\circ\text{C} \\ P_9 = 700 \text{ kPa} \end{array} \right\} s_9 = 6.6456 \text{ kJ/kg}$$

$$\left. \begin{array}{l} P_{10} = 100 \text{ kPa} \\ s_{10} = s_9 \end{array} \right\} h_{10s} = 764.01 \text{ kJ/kg}$$

$$\eta_T = \frac{h_9 - h_{10}}{h_9 - h_{10s}} \longrightarrow h_{10} = h_9 - \eta_T(h_9 - h_{10s}) \\ = 1305.2 - (0.80)(1305.2 - 764.01) \\ = 872.25 \text{ kJ/kg}$$

$$T_{11} = 200^\circ\text{C} \longrightarrow h_{11} = 475.77 \text{ kJ/kg}$$

From the steam tables (Tables A-4, A-5, and A-6 or from EES),

$$h_1 = h_f @ 10 \text{ kPa} = 191.81 \text{ kJ/kg}$$

$$v_1 = v_f @ 10 \text{ kPa} = 0.00101 \text{ m}^3/\text{kg}$$

$$w_{p,\text{lin}} = v_1(P_2 - P_1)/\eta_p \\ = (0.00101 \text{ m}^3/\text{kg})(6000 - 10 \text{ kPa}) \left(\frac{1 \text{ kJ}}{1 \text{ kPa} \cdot \text{m}^3} \right) / 0.80 \\ = 7.56 \text{ kJ/kg}$$

$$h_2 = h_1 + w_{p,\text{lin}} = 191.81 + 7.65 = 199.37 \text{ kJ/kg}$$

$$\left. \begin{array}{l} P_5 = 1 \text{ MPa} \\ T_5 = 400^\circ\text{C} \end{array} \right\} \begin{array}{l} h_5 = 3264.5 \text{ kJ/kg} \\ s_5 = 7.4670 \text{ kJ/kg} \cdot \text{K} \end{array}$$

$$\left. \begin{array}{l} P_6 = 10 \text{ kPa} \\ s_{6s} = s_5 \end{array} \right\} \begin{array}{l} x_{6s} = \frac{s_{6s} - s_f}{s_{fg}} = \frac{7.4670 - 0.6492}{7.4996} = 0.9091 \\ h_{6s} = h_f + x_{6s}h_{fg} = 191.81 + (0.9091)(2392.1) = 2366.4 \text{ kJ/kg} \end{array}$$

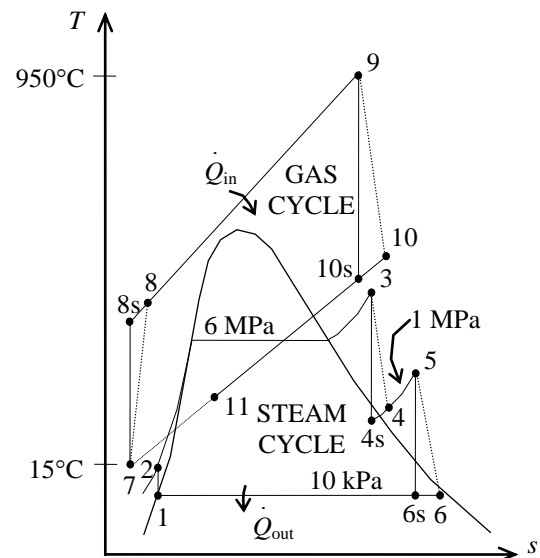
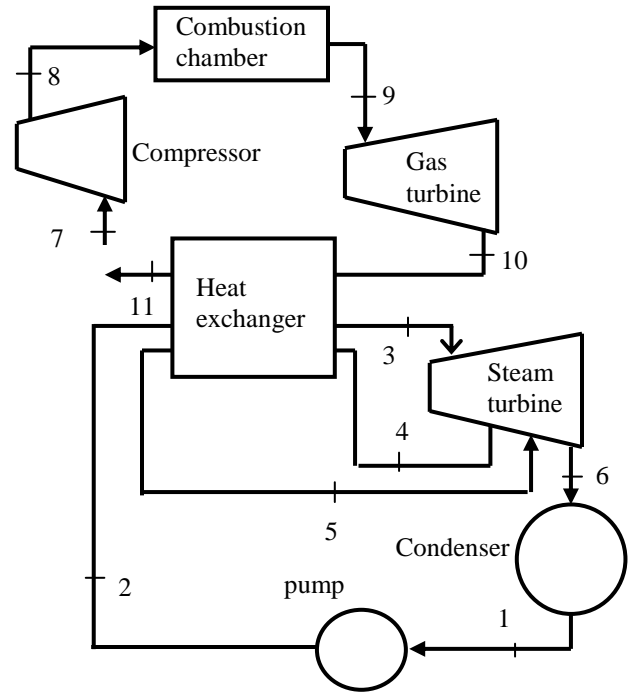

$$\eta_T = \frac{h_5 - h_6}{h_5 - h_{6s}} \longrightarrow h_6 = h_5 - \eta_T (h_5 - h_{6s})$$

$$= 3264.5 - (0.80)(3264.5 - 2366.4)$$

$$= 2546.0 \text{ kJ/kg}$$

$$\left. \begin{array}{l} P_6 = 10 \text{ kPa} \\ h_6 = 2546.5 \text{ kJ/kg} \end{array} \right\} x_6 = 0.9842$$

$$\text{Moisture Percentage} = 1 - x_6 = 1 - 0.9842 = 0.0158 = \mathbf{1.58\%}$$

(b) Noting that $\dot{Q} \cong \dot{W} \cong \Delta ke \cong \Delta pe \cong 0$ for the heat exchanger, the steady-flow energy balance equation yields

$$\dot{E}_{\text{in}} = \dot{E}_{\text{out}}$$

$$\sum \dot{m}_i h_i = \sum \dot{m}_e h_e$$

$$\dot{m}_s (h_3 - h_2) + \dot{m}_s (h_5 - h_4) = \dot{m}_{\text{air}} (h_{10} - h_{11})$$

$$(4.6)[(3350.3 - 199.37) + (3264.5 - h_4)] = (40)(872.25 - 475.77) \longrightarrow h_4 = 2967.8 \text{ kJ/kg}$$

Also,

$$\left. \begin{array}{l} P_3 = 6 \text{ MPa} \\ T_3 = ? \end{array} \right\} h_3 =$$

$$\left. \begin{array}{l} P_4 = 1 \text{ MPa} \\ s_{4s} = s_3 \end{array} \right\} h_{4s} =$$

$$\eta_T = \frac{h_3 - h_4}{h_3 - h_{4s}} \longrightarrow h_4 = h_3 - \eta_T (h_3 - h_{4s})$$

The temperature at the inlet of the high-pressure turbine may be obtained by a trial-error approach or using EES from the above relations. The answer is $T_3 = \mathbf{469.6^\circ\text{C}}$. Then, the enthalpy at state 3 becomes: $h_3 = 3350.3 \text{ kJ/kg}$

$$(c) \quad \dot{W}_{\text{T,gas}} = \dot{m}_{\text{air}} (h_9 - h_{10}) = (40 \text{ kg/s})(1305.2 - 872.25) \text{ kJ/kg} = 17,318 \text{ kW}$$

$$\dot{W}_{\text{C,gas}} = \dot{m}_{\text{air}} (h_8 - h_7) = (40 \text{ kg/s})(557.49 - 288.53) \text{ kJ/kg} = 10,758 \text{ kW}$$

$$\dot{W}_{\text{net,gas}} = \dot{W}_{\text{T,gas}} - \dot{W}_{\text{C,gas}} = 17,318 - 10,758 = 6560 \text{ kW}$$

$$\dot{W}_{\text{T,steam}} = \dot{m}_s (h_3 - h_4 + h_5 - h_6) = (4.6 \text{ kg/s})(3350.3 - 2967.8 + 3264.5 - 2546.0) \text{ kJ/kg} = 5065 \text{ kW}$$

$$\dot{W}_{\text{P,steam}} = \dot{m}_s w_{\text{pump}} = (4.6 \text{ kg/s})(7.564) \text{ kJ/kg} = 34.8 \text{ kW}$$

$$\dot{W}_{\text{net,steam}} = \dot{W}_{\text{T,steam}} - \dot{W}_{\text{P,steam}} = 5065 - 34.8 = 5030 \text{ kW}$$

$$\dot{W}_{\text{net,plant}} = \dot{W}_{\text{net,gas}} + \dot{W}_{\text{net,steam}} = 6560 + 5030 = \mathbf{11,590 \text{ kW}}$$

$$(d) \quad \dot{Q}_{\text{in}} = \dot{m}_{\text{air}} (h_9 - h_8) = (40 \text{ kg/s})(1305.2 - 557.49) \text{ kJ/kg} = 29,908 \text{ kW}$$

$$\eta_{\text{th}} = \frac{\dot{W}_{\text{net,plant}}}{\dot{Q}_{\text{in}}} = \frac{11,590 \text{ kW}}{29,908 \text{ kW}} = 0.3875 = \mathbf{38.8\%}$$

The EES code for the solution of this problem is as follows:

"GIVEN"

P[7]=100 [kPa] "assumed"

r=7; P[8]=r*P[7]; P[9]=P[8]; P[10]=P[7]; P[11]=P[7]

T[7]=15 [C]; T[9]=950 [C]; T[11]=200 [C]

m_dot_gas=40 [kg/s]; m_dot_steam=4.6 [kg/s]

P[3]=6000 [kPa]; P[6]=10 [kPa]; P[2]=P[3]; P[1]=P[6]

T[5]=400 [C]; P[5]=1000 [kPa]; P[4]=P[5]

eta_C=0.80; eta_T=0.80; eta_P=0.80

"PROPERTIES, gas cycle"

```

GasFluid$='Air'
h[7]=enthalpy(GasFluid$, T=T[7])
s[7]=entropy(GasFluid$, T=T[7], P=P[7])
h_8s=enthalpy(GasFluid$, P=P[8], s=s[7])
h[8]=h[7]+(h_8s-h[7])/eta_C
h[9]=enthalpy(GasFluid$, T=T[9])
s[9]=entropy(GasFluid$, P=P[9], T=T[9])
h_10s=enthalpy(GasFluid$, P=P[10], s=s[9])
h[10]=h[9]-eta_T*(h[9]-h_10s)
T[10]=temperature(GasFluid$, h=h[10])
h[11]=enthalpy(GasFluid$, T=T[11])

```

"PROPERTIES, steam cycle"

```

SteamFluid$='Steam_iapws'
h[1]=enthalpy(SteamFluid$, P=P[1], x=0)
v_1=volume(SteamFluid$, P=P[1], x=0)
w_pump=v_1*(P[2]-P[1])/eta_P
h[2]=h[1]+w_pump
h[5]=enthalpy(SteamFluid$, P=P[5], T=T[5])
s[5]=entropy(SteamFluid$, P=P[5], T=T[5])
h_6s=enthalpy(SteamFluid$, P=P[6], s=s[5])
x_6s=quality(SteamFluid$, P=P[6], s=s[5])
h[6]=h[5]-eta_T*(h[5]-h_6s)
h[3]=enthalpy(SteamFluid$, P=P[3], T=T[3])
s[3]=entropy(SteamFluid$, P=P[3], T=T[3])
h_4s=enthalpy(SteamFluid$, P=P[4], s=s[3])
h[4]=h[3]-eta_T*(h[3]-h_4s)

```

"ANALYSIS"

```

m_dot_gas*(h[10]-h[11])=m_dot_steam*(h[3]-h[2])+m_dot_steam*(h[5]-h[4]) "energy balance on heat
exchanger"
T_3=T[3] "temperature of steam at the turbine inlet"
x_6=quality(SteamFluid$, P=P[6], h=h[6])
MoisturePercentage=(1-x_6)*Convert(, %) "moisture percentage at the turbine exit"
W_dot_T_gas=m_dot_gas*(h[9]-h[10])
W_dot_C_gas=m_dot_gas*(h[8]-h[7])
W_dot_net_gas=W_dot_T_gas-W_dot_C_gas
W_dot_T_steam=m_dot_steam*(h[3]-h[4]+h[5]-h[6])
W_dot_P_steam=m_dot_steam*w_pump
W_dot_net_steam=W_dot_T_steam-W_dot_P_steam
W_dot_net_plant=W_dot_net_gas+W_dot_net_steam "net power from the plant"
Q_dot_in=m_dot_gas*(h[9]-h[8])
Q_dot_out=m_dot_steam*(h[6]-h[1])+m_dot_gas*(h[11]-h[7])
eta_th=W_dot_net_plant/Q_dot_in "thermal efficiency"

```

Special Topic: Binary Vapor Cycles

10-85C Steam is not an ideal fluid for vapor power cycles because its critical temperature is low, its saturation dome resembles an inverted V, and its condenser pressure is too low.

10-86C Binary power cycle is a cycle which is actually a combination of two cycles; one in the high temperature region, and the other in the low temperature region. Its purpose is to increase thermal efficiency.

10-87C In binary vapor power cycles, both cycles are vapor cycles. In the combined gas-steam power cycle, one of the cycles is a gas cycle.

10-88C Because mercury has a high critical temperature, relatively low critical pressure, but a very low condenser pressure. It is also toxic, expensive, and has a low enthalpy of vaporization.

10-89 Consider the heat exchanger of a binary power cycle. The working fluid of the topping cycle (cycle A) enters the heat exchanger at state 1 and leaves at state 2. The working fluid of the bottoming cycle (cycle B) enters at state 3 and leaves at state 4. Neglecting any changes in kinetic and potential energies, and assuming the heat exchanger is well-insulated, the steady-flow energy balance relation yields

$$\begin{aligned}\dot{E}_{\text{in}} - \dot{E}_{\text{out}} &= \Delta \dot{E}_{\text{system}} \stackrel{\text{0 (steady)}}{=} 0 \\ \dot{E}_{\text{in}} &= \dot{E}_{\text{out}} \\ \sum \dot{m}_e h_e &= \sum \dot{m}_i h_i \\ \dot{m}_A h_2 + \dot{m}_B h_4 &= \dot{m}_A h_1 + \dot{m}_B h_3 \text{ or } \dot{m}_A (h_2 - h_1) = \dot{m}_B (h_3 - h_4)\end{aligned}$$

Thus,

$$\frac{\dot{m}_A}{\dot{m}_B} = \frac{h_3 - h_4}{h_2 - h_1}$$

Review Problems

10-90 A steam power plant operates on the simple ideal Rankine cycle. The turbine inlet temperature, the net power output, the thermal efficiency, and the minimum mass flow rate of the cooling water required are to be determined.

Assumptions 1 Steady operating conditions exist. 2 Kinetic and potential energy changes are negligible.

Analysis (a) From the steam tables (Tables A-4, A-5, and A-6),

$$h_1 = h_f @ 7.5 \text{ kPa} = 168.75 \text{ kJ/kg}$$

$$v_1 = v_f @ 7.5 \text{ kPa} = 0.001008 \text{ m}^3/\text{kg}$$

$$T_1 = T_{\text{sat}} @ 7.5 \text{ kPa} = 40.29^\circ\text{C}$$

$$\begin{aligned} w_{p,\text{in}} &= v_1(P_2 - P_1) \\ &= (0.001008 \text{ m}^3/\text{kg})(6000 - 7.5 \text{ kPa}) \left(\frac{1 \text{ kJ}}{1 \text{ kPa} \cdot \text{m}^3} \right) \\ &= 6.04 \text{ kJ/kg} \end{aligned}$$

$$h_2 = h_1 + w_{p,\text{in}} = 168.75 + 6.04 = 174.79 \text{ kJ/kg}$$

$$h_4 = h_g @ 7.5 \text{ kPa} = 2574.0 \text{ kJ/kg}$$

$$s_4 = s_g @ 7.5 \text{ kPa} = 8.2501 \text{ kJ/kg}$$

$$\left. \begin{aligned} P_3 &= 6 \text{ MPa} \\ s_3 &= s_4 \end{aligned} \right\} \begin{aligned} h_3 &= 4852.2 \text{ kJ/kg} \\ T_3 &= 1089.2^\circ\text{C} \end{aligned}$$

$$(b) \quad q_{\text{in}} = h_3 - h_2 = 4852.2 - 174.79 = 4677.4 \text{ kJ/kg}$$

$$q_{\text{out}} = h_4 - h_1 = 2574.0 - 168.75 = 2405.3 \text{ kJ/kg}$$

$$w_{\text{net}} = q_{\text{in}} - q_{\text{out}} = 4677.4 - 2405.3 = 2272.1 \text{ kJ/kg}$$

and

$$\eta_{\text{th}} = \frac{w_{\text{net}}}{q_{\text{in}}} = \frac{2272.1 \text{ kJ/kg}}{4677.4 \text{ kJ/kg}} = \mathbf{48.6\%}$$

Thus,

$$\dot{W}_{\text{net}} = \eta_{\text{th}} \dot{Q}_{\text{in}} = (0.4857)(40,000 \text{ kJ/s}) = \mathbf{19,428 \text{ kJ/s}}$$

(c) The mass flow rate of the cooling water will be minimum when it is heated to the temperature of the steam in the condenser, which is 40.29°C ,

$$\dot{Q}_{\text{out}} = \dot{Q}_{\text{in}} - \dot{W}_{\text{net}} = 40,000 - 19,428 = 20,572 \text{ kJ/s}$$

$$\dot{m}_{\text{cool}} = \frac{\dot{Q}_{\text{out}}}{c\Delta T} = \frac{20,572 \text{ kJ/s}}{(4.18 \text{ kJ/kg} \cdot ^\circ\text{C})(40.29 - 15^\circ\text{C})} = \mathbf{194.6 \text{ kg/s}}$$

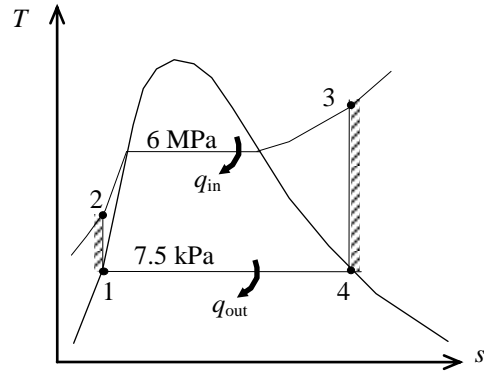

10-91 A simple ideal Rankine cycle with water as the working fluid operates between the specified pressure limits. The thermal efficiency of the cycle is to be compared when it is operated so that the liquid enters the pump as a saturated liquid against that when the liquid enters as a subcooled liquid.

determined power produced by the turbine and consumed by the pump are to be determined.

Assumptions 1 Steady operating conditions exist. 2 Kinetic and potential energy changes are negligible.

Analysis From the steam tables (Tables A-4, A-5, and A-6),

$$\begin{aligned}
 h_1 &= h_f @ 50 \text{ kPa} = 340.54 \text{ kJ/kg} \\
 v_1 &= v_f @ 20 \text{ kPa} = 0.001030 \text{ m}^3/\text{kg} \\
 w_{p,\text{in}} &= v_1 (P_2 - P_1) \\
 &= (0.001030 \text{ m}^3/\text{kg})(6000 - 50) \text{ kPa} \left(\frac{1 \text{ kJ}}{1 \text{ kPa} \cdot \text{m}^3} \right) \\
 &= 6.13 \text{ kJ/kg} \\
 h_2 &= h_1 + w_{p,\text{in}} = 340.54 + 6.13 = 346.67 \text{ kJ/kg} \\
 \left. \begin{array}{l} P_3 = 6000 \text{ kPa} \\ T_3 = 600^\circ\text{C} \end{array} \right\} & \begin{array}{l} h_3 = 3658.8 \text{ kJ/kg} \\ s_3 = 7.1693 \text{ kJ/kg} \cdot \text{K} \end{array} \\
 \left. \begin{array}{l} P_4 = 50 \text{ kPa} \\ s_4 = s_3 \end{array} \right\} & \begin{array}{l} x_4 = \frac{s_4 - s_f}{s_{fg}} = \frac{7.1693 - 1.0912}{6.5019} = 0.9348 \\ h_4 = h_f + x_4 h_{fg} = 340.54 + (0.9348)(2304.7) = 2495.0 \text{ kJ/kg} \end{array}
 \end{aligned}$$

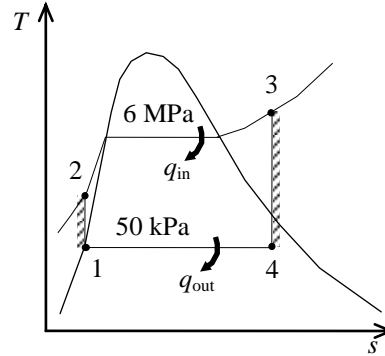

Thus,

$$\begin{aligned}
 q_{\text{in}} &= h_3 - h_2 = 3658.8 - 346.67 = 3312.1 \text{ kJ/kg} \\
 q_{\text{out}} &= h_4 - h_1 = 2495.0 - 340.54 = 2154.5 \text{ kJ/kg}
 \end{aligned}$$

and the thermal efficiency of the cycle is

$$\eta_{\text{th}} = 1 - \frac{q_{\text{out}}}{q_{\text{in}}} = 1 - \frac{2154.5}{3312.1} = \mathbf{0.3495}$$

When the liquid enters the pump 11.3°C cooler than a saturated liquid at the condenser pressure, the enthalpies become

$$\left. \begin{array}{l} P_1 = 50 \text{ kPa} \\ T_1 = T_{\text{sat}} @ 50 \text{ kPa} - 11.3 = 81.3 - 11.3 = 70^\circ\text{C} \end{array} \right\} \begin{array}{l} h_1 \cong h_f @ 70^\circ\text{C} = 293.07 \text{ kJ/kg} \\ v_1 \cong v_f @ 70^\circ\text{C} = 0.001023 \text{ m}^3/\text{kg} \end{array}$$

$$\begin{aligned}
 w_{p,\text{in}} &= v_1 (P_2 - P_1) \\
 &= (0.001023 \text{ m}^3/\text{kg})(6000 - 50) \text{ kPa} \left(\frac{1 \text{ kJ}}{1 \text{ kPa} \cdot \text{m}^3} \right) \\
 &= 6.09 \text{ kJ/kg}
 \end{aligned}$$

$$h_2 = h_1 + w_{p,\text{in}} = 293.07 + 6.09 = 299.16 \text{ kJ/kg}$$

Then,

$$\begin{aligned}
 q_{\text{in}} &= h_3 - h_2 = 3658.8 - 299.16 = 3359.6 \text{ kJ/kg} \\
 q_{\text{out}} &= h_4 - h_1 = 2495.0 - 293.09 = 2201.9 \text{ kJ/kg}
 \end{aligned}$$

$$\eta_{\text{th}} = 1 - \frac{q_{\text{out}}}{q_{\text{in}}} = 1 - \frac{2201.9}{3359.6} = \mathbf{0.3446}$$

The thermal efficiency slightly decreases as a result of subcooling at the pump inlet.

10-92 A steam power plant operating on an ideal Rankine cycle with two stages of reheat is considered. The thermal efficiency of the cycle and the mass flow rate of the steam are to be determined.

Assumptions 1 Steady operating conditions exist. 2 Kinetic and potential energy changes are negligible.

Analysis (a) From the steam tables (Tables A-4, A-5, and A-6),

$$\begin{aligned} h_1 &= h_f @ 30 \text{ kPa} = 289.18 \text{ kJ/kg} \\ \nu_1 &= \nu_f @ 30 \text{ kPa} = 0.001022 \text{ m}^3/\text{kg} \\ w_{p,\text{in}} &= \nu_1 (P_2 - P_1) \\ &= (0.001022 \text{ m}^3/\text{kg})(10,000 - 30 \text{ kPa}) \left(\frac{1 \text{ kJ}}{1 \text{ kPa} \cdot \text{m}^3} \right) \\ &= 10.19 \text{ kJ/kg} \end{aligned}$$

$$h_2 = h_1 + w_{p,\text{in}} = 289.18 + 10.19 = 299.37 \text{ kJ/kg}$$

$$\left. \begin{aligned} P_3 &= 10 \text{ MPa} \\ T_3 &= 550^\circ\text{C} \end{aligned} \right\} \begin{aligned} h_3 &= 3500.9 \text{ kJ/kg} \\ s_3 &= 6.7561 \text{ kJ/kg} \cdot \text{K} \end{aligned}$$

$$\left. \begin{aligned} P_4 &= 4 \text{ MPa} \\ s_4 &= s_3 \end{aligned} \right\} h_4 = 3204.9 \text{ kJ/kg}$$

$$\left. \begin{aligned} P_5 &= 4 \text{ MPa} \\ T_5 &= 550^\circ\text{C} \end{aligned} \right\} \begin{aligned} h_5 &= 3559.7 \text{ kJ/kg} \\ s_5 &= 7.2335 \text{ kJ/kg} \cdot \text{K} \end{aligned}$$

$$\left. \begin{aligned} P_6 &= 2 \text{ MPa} \\ s_6 &= s_5 \end{aligned} \right\} h_6 = 3321.1 \text{ kJ/kg}$$

$$\left. \begin{aligned} P_7 &= 2 \text{ MPa} \\ T_7 &= 550^\circ\text{C} \end{aligned} \right\} \begin{aligned} h_7 &= 3578.4 \text{ kJ/kg} \\ s_7 &= 7.5706 \text{ kJ/kg} \cdot \text{K} \end{aligned}$$

$$\left. \begin{aligned} P_8 &= 30 \text{ kPa} \\ s_8 &= s_7 \end{aligned} \right\} \begin{aligned} x_8 &= \frac{s_8 - s_f}{s_{fg}} = \frac{7.5706 - 0.9441}{6.8234} = 0.9711 \\ h_8 &= h_f + x_8 h_{fg} = 289.27 + (0.9711)(2335.3) = 2557.1 \text{ kJ/kg} \end{aligned}$$

Then,

$$\begin{aligned} q_{\text{in}} &= (h_3 - h_2) + (h_5 - h_4) + (h_7 - h_6) \\ &= 3500.9 - 299.37 + 3559.7 - 3204.9 + 3578.4 - 3321.1 = 3813.7 \text{ kJ/kg} \end{aligned}$$

$$q_{\text{out}} = h_8 - h_1 = 2557.1 - 289.18 = 2267.9 \text{ kJ/kg}$$

$$w_{\text{net}} = q_{\text{in}} - q_{\text{out}} = 3813.7 - 2267.9 = 1545.8 \text{ kJ/kg}$$

Thus,

$$\eta_{\text{th}} = \frac{w_{\text{net}}}{q_{\text{in}}} = \frac{1545.8 \text{ kJ/kg}}{3813.7 \text{ kJ/kg}} = 0.4053 = \mathbf{40.5\%}$$

(b) The mass flow rate of the steam is then

$$\dot{m} = \frac{\dot{W}_{\text{net}}}{w_{\text{net}}} = \frac{75,000 \text{ kJ/s}}{1545.8 \text{ kJ/kg}} = \mathbf{48.5 \text{ kg/s}}$$

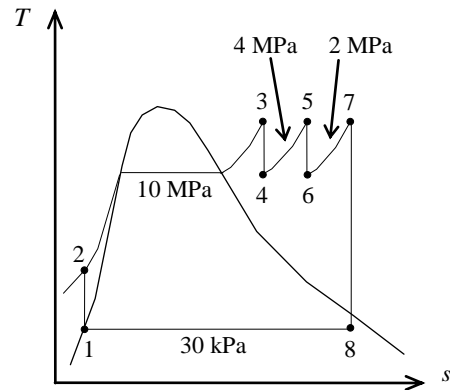

10-93 A steam power plant operating on the ideal Rankine cycle with reheating is considered. The reheat pressures of the cycle are to be determined for the cases of single and double reheat.

Assumptions 1 Steady operating conditions exist. 2 Kinetic and potential energy changes are negligible.

Analysis (a) Single Reheat: From the steam tables (Tables A-4, A-5, and A-6 or EES),

$$\left. \begin{array}{l} P_6 = 10 \text{ kPa} \\ x_6 = 0.95 \end{array} \right\} \begin{array}{l} h_6 = h_f + x_6 h_{fg} = 191.81 + (0.95)(2392.1) = 2464.3 \text{ kJ/kg} \\ s_6 = s_f + x_6 s_{fg} = 0.6492 + (0.95)(7.4996) = 7.7739 \text{ kJ/kg} \cdot \text{K} \end{array}$$

$$\left. \begin{array}{l} T_5 = 700^\circ\text{C} \\ s_5 = s_6 \end{array} \right\} P_5 = \mathbf{2908 \text{ kPa}}$$

(b) Double Reheat:

$$\left. \begin{array}{l} P_3 = 30 \text{ MPa} \\ T_3 = 700^\circ\text{C} \end{array} \right\} s_3 = 6.5599 \text{ kJ/kg} \cdot \text{K}$$

$$\left. \begin{array}{l} P_4 = P_x \\ s_4 = s_3 \end{array} \right\} \text{and} \quad \left. \begin{array}{l} P_5 = P_x \\ T_5 = 700^\circ\text{C} \end{array} \right\}$$

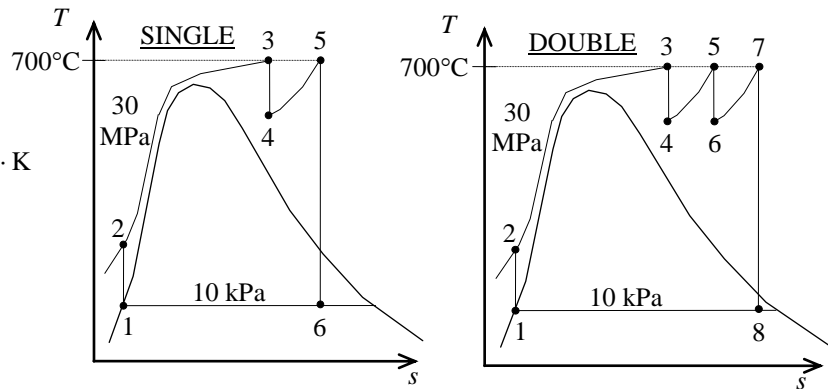

Any pressure P_x selected between the limits of 30 MPa and 2.908 MPa will satisfy the requirements, and can be used for the double reheat pressure.

10-94 An 150-MW steam power plant operating on a regenerative Rankine cycle with an open feedwater heater is considered. The mass flow rate of steam through the boiler, the thermal efficiency of the cycle, and the irreversibility associated with the regeneration process are to be determined.

Assumptions 1 Steady operating conditions exist. 2 Kinetic and potential energy changes are negligible.

Analysis

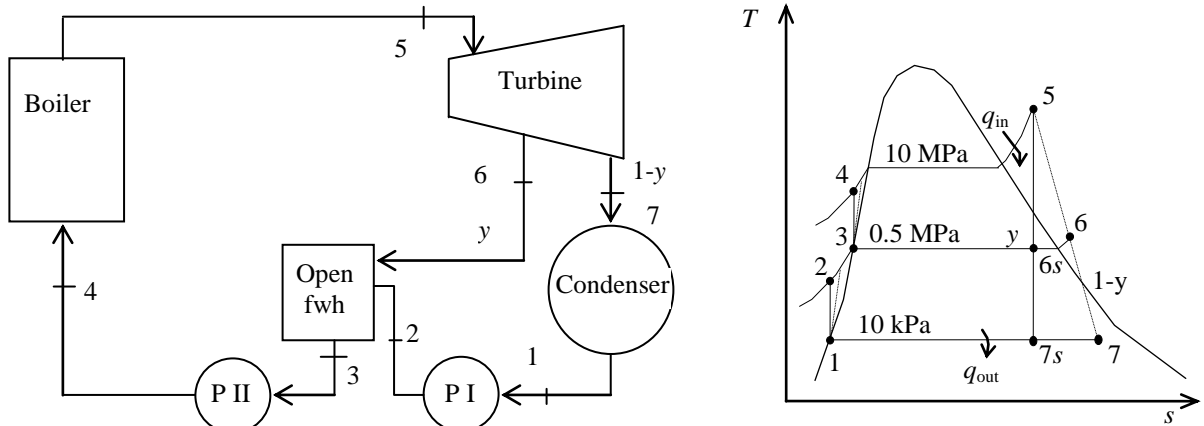

(a) From the steam tables (Tables A-4, A-5, and A-6),

$$h_1 = h_f @ 10 \text{ kPa} = 191.81 \text{ kJ/kg}$$

$$v_1 = v_f @ 10 \text{ kPa} = 0.00101 \text{ m}^3/\text{kg}$$

$$\begin{aligned} w_{pI, \text{in}} &= v_1(P_2 - P_1)/\eta_p \\ &= (0.00101 \text{ m}^3/\text{kg})(500 - 10 \text{ kPa}) \left(\frac{1 \text{ kJ}}{1 \text{ kPa} \cdot \text{m}^3} \right) / (0.95) \\ &= 0.52 \text{ kJ/kg} \end{aligned}$$

$$h_2 = h_1 + w_{pI, \text{in}} = 191.81 + 0.52 = 192.33 \text{ kJ/kg}$$

$$\left. \begin{array}{l} P_3 = 0.5 \text{ MPa} \\ \text{sat. liquid} \end{array} \right\} \begin{array}{l} h_3 = h_f @ 0.5 \text{ MPa} = 640.09 \text{ kJ/kg} \\ v_3 = v_f @ 0.5 \text{ MPa} = 0.001093 \text{ m}^3/\text{kg} \end{array}$$

$$\begin{aligned} w_{pII, \text{in}} &= v_3(P_4 - P_3)/\eta_p \\ &= (0.001093 \text{ m}^3/\text{kg})(10,000 - 500 \text{ kPa}) \left(\frac{1 \text{ kJ}}{1 \text{ kPa} \cdot \text{m}^3} \right) / (0.95) \\ &= 10.93 \text{ kJ/kg} \end{aligned}$$

$$h_4 = h_3 + w_{pII, \text{in}} = 640.09 + 10.93 = 651.02 \text{ kJ/kg}$$

$$\left. \begin{array}{l} P_5 = 10 \text{ MPa} \\ T_5 = 500^\circ\text{C} \end{array} \right\} \begin{array}{l} h_5 = 3375.1 \text{ kJ/kg} \\ s_5 = 6.5995 \text{ kJ/kg} \cdot \text{K} \end{array}$$

$$x_{6s} = \frac{s_{6s} - s_f}{s_{fg}} = \frac{6.5995 - 1.8604}{4.9603} = 0.9554$$

$$\left. \begin{array}{l} P_{6s} = 0.5 \text{ MPa} \\ s_{6s} = s_5 \end{array} \right\} \begin{array}{l} h_{6s} = h_f + x_{6s} h_{fg} = 640.09 + (0.9554)(2108.0) \\ = 2654.1 \text{ kJ/kg} \end{array}$$

$$\begin{aligned} \eta_T = \frac{h_5 - h_6}{h_5 - h_{6s}} &\longrightarrow h_6 = h_5 - \eta_T(h_5 - h_{6s}) \\ &= 3375.1 - (0.80)(3375.1 - 2654.1) \\ &= 2798.3 \text{ kJ/kg} \end{aligned}$$

$$x_{7s} = \frac{s_{7s} - s_f}{s_{fg}} = \frac{6.5995 - 0.6492}{7.4996} = 0.7934$$

$$P_{7s} = 10 \text{ kPa} \left\{ \begin{array}{l} h_{7s} = h_f + x_{7s} h_{fg} = 191.81 + (0.7934)(2392.1) \\ s_{7s} = s_5 \end{array} \right. \left. \begin{array}{l} = 2089.7 \text{ kJ/kg} \end{array} \right.$$

$$\eta_T = \frac{h_5 - h_7}{h_5 - h_{7s}} \longrightarrow h_7 = h_5 - \eta_T (h_5 - h_{7s})$$

$$= 3375.1 - (0.80)(3375.1 - 2089.7)$$

$$= 2346.8 \text{ kJ/kg}$$

The fraction of steam extracted is determined from the steady-flow energy balance equation applied to the feedwater heaters. Noting that $\dot{Q} \cong \dot{W} \cong \Delta ke \cong \Delta pe \cong 0$,

$$\dot{E}_{\text{in}} - \dot{E}_{\text{out}} = \Delta \dot{E}_{\text{system}} \overset{\phi 0(\text{steady})}{=} 0$$

$$\dot{E}_{\text{in}} = \dot{E}_{\text{out}}$$

$$\sum \dot{m}_i h_i = \sum \dot{m}_e h_e \longrightarrow \dot{m}_6 h_6 + \dot{m}_2 h_2 = \dot{m}_3 h_3 \longrightarrow y h_6 + (1 - y) h_2 = 1(h_3)$$

where y is the fraction of steam extracted from the turbine ($= \dot{m}_6 / \dot{m}_3$). Solving for y ,

$$y = \frac{h_3 - h_2}{h_6 - h_2} = \frac{640.09 - 192.33}{2798.3 - 192.33} = 0.1718$$

Then,

$$q_{\text{in}} = h_5 - h_4 = 3375.1 - 651.02 = 2724.1 \text{ kJ/kg}$$

$$q_{\text{out}} = (1 - y)(h_7 - h_1) = (1 - 0.1718)(2346.8 - 191.81) = 1784.7 \text{ kJ/kg}$$

$$w_{\text{net}} = q_{\text{in}} - q_{\text{out}} = 2724.1 - 1784.7 = 939.4 \text{ kJ/kg}$$

and

$$\dot{m} = \frac{\dot{W}_{\text{net}}}{w_{\text{net}}} = \frac{150,000 \text{ kJ/s}}{939.4 \text{ kJ/kg}} = \mathbf{159.7 \text{ kg/s}}$$

(b) The thermal efficiency is determined from

$$\eta_{\text{th}} = 1 - \frac{q_{\text{out}}}{q_{\text{in}}} = 1 - \frac{1784.7 \text{ kJ/kg}}{2724.1 \text{ kJ/kg}} = \mathbf{34.5\%}$$

Also,

$$\left. \begin{array}{l} P_6 = 0.5 \text{ MPa} \\ h_6 = 2798.3 \text{ kJ/kg} \end{array} \right\} s_6 = 6.9453 \text{ kJ/kg} \cdot \text{K}$$

$$s_3 = s_f @ 0.5 \text{ MPa} = 1.8604 \text{ kJ/kg} \cdot \text{K}$$

$$s_2 = s_1 = s_f @ 10 \text{ kPa} = 0.6492 \text{ kJ/kg} \cdot \text{K}$$

Then the irreversibility (or exergy destruction) associated with this regeneration process is

$$i_{\text{regen}} = T_0 s_{\text{gen}} = T_0 \left(\sum m_e s_e - \sum m_i s_i + \frac{q_{\text{sun}}}{T_L} \overset{\phi 0}{=} \right) = T_0 [s_3 - y s_6 - (1 - y) s_2]$$

$$= (303 \text{ K}) [1.8604 - (0.1718)(6.9453) - (1 - 0.1718)(0.6492)]$$

$$= \mathbf{39.25 \text{ kJ/kg}}$$

10-95 A 150-MW steam power plant operating on an ideal regenerative Rankine cycle with an open feedwater heater is considered. The mass flow rate of steam through the boiler, the thermal efficiency of the cycle, and the irreversibility associated with the regeneration process are to be determined.

Assumptions 1 Steady operating conditions exist. 2 Kinetic and potential energy changes are negligible.

Analysis

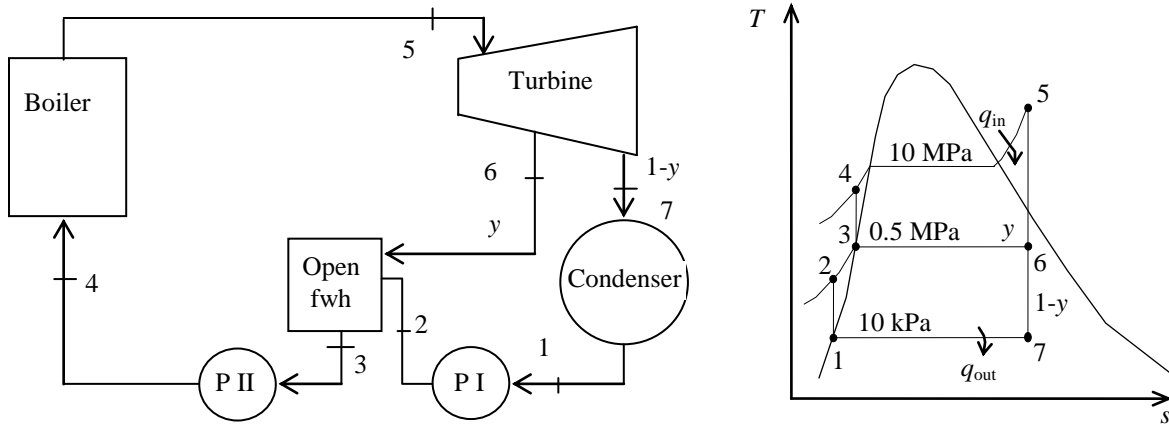

(a) From the steam tables (Tables A-4, A-5, and A-6),

$$h_1 = h_f @ 10 \text{ kPa} = 191.81 \text{ kJ/kg}$$

$$\nu_1 = \nu_f @ 10 \text{ kPa} = 0.00101 \text{ m}^3/\text{kg}$$

$$w_{pI,\text{in}} = \nu_1(P_2 - P_1) = (0.00101 \text{ m}^3/\text{kg})(500 - 10 \text{ kPa}) \left(\frac{1 \text{ kJ}}{1 \text{ kPa} \cdot \text{m}^3} \right) = 0.50 \text{ kJ/kg}$$

$$h_2 = h_1 + w_{pI,\text{in}} = 191.81 + 0.50 = 192.30 \text{ kJ/kg}$$

$$\left. \begin{array}{l} P_3 = 0.5 \text{ MPa} \\ \text{sat. liquid} \end{array} \right\} \begin{array}{l} h_3 = h_f @ 0.5 \text{ MPa} = 640.09 \text{ kJ/kg} \\ \nu_3 = \nu_f @ 0.5 \text{ MPa} = 0.001093 \text{ m}^3/\text{kg} \end{array}$$

$$w_{pII,\text{in}} = \nu_3(P_4 - P_3) = (0.001093 \text{ m}^3/\text{kg})(10,000 - 500 \text{ kPa}) \left(\frac{1 \text{ kJ}}{1 \text{ kPa} \cdot \text{m}^3} \right) = 10.38 \text{ kJ/kg}$$

$$h_4 = h_3 + w_{pII,\text{in}} = 640.09 + 10.38 = 650.47 \text{ kJ/kg}$$

$$\left. \begin{array}{l} P_5 = 10 \text{ MPa} \\ T_5 = 500^\circ\text{C} \end{array} \right\} \begin{array}{l} h_5 = 3375.1 \text{ kJ/kg} \\ s_5 = 6.5995 \text{ kJ/kg} \cdot \text{K} \end{array}$$

$$\left. \begin{array}{l} P_6 = 0.5 \text{ MPa} \\ s_6 = s_5 \end{array} \right\} \begin{array}{l} x_6 = \frac{s_6 - s_f}{s_{fg}} = \frac{6.5995 - 1.8604}{4.9603} = 0.9554 \\ h_6 = h_f + x_6 h_{fg} = 640.09 + (0.9554)(2108.0) = 2654.1 \text{ kJ/kg} \end{array}$$

$$\left. \begin{array}{l} P_7 = 10 \text{ kPa} \\ s_7 = s_5 \end{array} \right\} \begin{array}{l} x_7 = \frac{s_7 - s_f}{s_{fg}} = \frac{6.5995 - 0.6492}{7.4996} = 0.7934 \\ h_7 = h_f + x_7 h_{fg} = 191.81 + (0.7934)(2392.1) = 2089.7 \text{ kJ/kg} \end{array}$$

The fraction of steam extracted is determined from the steady-flow energy equation applied to the feedwater heaters. Noting that $\dot{Q} \cong \dot{W} \cong \Delta ke \cong \Delta pe \cong 0$,

$$\dot{E}_{\text{in}} - \dot{E}_{\text{out}} = \Delta \dot{E}_{\text{system}} \stackrel{\phi^0(\text{steady})}{=} 0 \rightarrow \dot{E}_{\text{in}} = \dot{E}_{\text{out}}$$

$$\sum \dot{m}_i h_i = \sum \dot{m}_e h_e \longrightarrow \dot{m}_6 h_6 + \dot{m}_2 h_2 = \dot{m}_3 h_3 \longrightarrow y h_6 + (1 - y) h_2 = 1(h_3)$$

where y is the fraction of steam extracted from the turbine ($= \dot{m}_6 / \dot{m}_3$). Solving for y ,

$$y = \frac{h_3 - h_2}{h_6 - h_2} = \frac{640.09 - 192.31}{2654.1 - 192.31} = 0.1819$$

Then, $q_{\text{in}} = h_5 - h_4 = 3375.1 - 650.47 = 2724.6 \text{ kJ/kg}$
 $q_{\text{out}} = (1 - y)(h_7 - h_1) = (1 - 0.1819)(2089.7 - 191.81) = 1552.7 \text{ kJ/kg}$
 $w_{\text{net}} = q_{\text{in}} - q_{\text{out}} = 2724.6 - 1552.7 = 1172.0 \text{ kJ/kg}$

and $\dot{m} = \frac{\dot{W}_{\text{net}}}{w_{\text{net}}} = \frac{150,000 \text{ kJ/s}}{1171.9 \text{ kJ/kg}} = \mathbf{128.0 \text{ kg/s}}$

(b) The thermal efficiency is determined from

$$\eta_{\text{th}} = 1 - \frac{q_{\text{out}}}{q_{\text{in}}} = 1 - \frac{1552.7 \text{ kJ/kg}}{2724.7 \text{ kJ/kg}} = \mathbf{43.0\%}$$

Also,

$$s_6 = s_5 = 6.5995 \text{ kJ/kg} \cdot \text{K}$$

$$s_3 = s_f @ 0.5 \text{ MPa} = 1.8604 \text{ kJ/kg} \cdot \text{K}$$

$$s_2 = s_1 = s_f @ 10 \text{ kPa} = 0.6492 \text{ kJ/kg} \cdot \text{K}$$

Then the irreversibility (or exergy destruction) associated with this regeneration process is

$$i_{\text{regen}} = T_0 s_{\text{gen}} = T_0 \left(\sum m_e s_e - \sum m_i s_i + \frac{q_{\text{sun}}}{T_L} \right) = T_0 [s_3 - y s_6 - (1 - y) s_2]$$

$$= (303 \text{ K}) [1.8604 - (0.1819)(6.5995) - (1 - 0.1819)(0.6492)]$$

$$= \mathbf{39.0 \text{ kJ/kg}}$$

10-96 An ideal reheat-regenerative Rankine cycle with one open feedwater heater is considered. The fraction of steam extracted for regeneration and the thermal efficiency of the cycle are to be determined.

Assumptions 1 Steady operating conditions exist. 2 Kinetic and potential energy changes are negligible.

Analysis (a) From the steam tables (Tables A-4, A-5, and A-6),

$$h_1 = h_f @ 15 \text{ kPa} = 225.94 \text{ kJ/kg}$$

$$v_1 = v_f @ 15 \text{ kPa} = 0.001014 \text{ m}^3/\text{kg}$$

$$w_{pI, \text{in}} = v_1(P_2 - P_1) = (0.001014 \text{ m}^3/\text{kg})(600 - 15 \text{ kPa}) \left(\frac{1 \text{ kJ}}{1 \text{ kPa} \cdot \text{m}^3} \right) = 0.59 \text{ kJ/kg}$$

$$h_2 = h_1 + w_{pI, \text{in}} = 225.94 + 0.59 = 226.53 \text{ kJ/kg}$$

$$P_3 = 0.6 \text{ MPa} \left. \begin{array}{l} h_3 = h_f @ 0.6 \text{ MPa} = 670.38 \text{ kJ/kg} \\ \text{sat. liquid} \end{array} \right\} v_3 = v_f @ 0.6 \text{ MPa} = 0.001101 \text{ m}^3/\text{kg}$$

$$w_{pII, \text{in}} = v_3(P_4 - P_3) = (0.001101 \text{ m}^3/\text{kg})(10,000 - 600 \text{ kPa}) \left(\frac{1 \text{ kJ}}{1 \text{ kPa} \cdot \text{m}^3} \right) = 10.35 \text{ kJ/kg}$$

$$h_4 = h_3 + w_{pII, \text{in}} = 670.38 + 10.35 = 680.73 \text{ kJ/kg}$$

$$P_5 = 10 \text{ MPa} \left. \begin{array}{l} h_5 = 3375.1 \text{ kJ/kg} \\ T_5 = 500^\circ\text{C} \end{array} \right\} s_5 = 6.5995 \text{ kJ/kg} \cdot \text{K}$$

$$P_6 = 1.0 \text{ MPa} \left. \begin{array}{l} h_6 = 2783.8 \text{ kJ/kg} \\ s_6 = s_5 \end{array} \right\}$$

$$P_7 = 1.0 \text{ MPa} \left. \begin{array}{l} h_7 = 3479.1 \text{ kJ/kg} \\ T_7 = 500^\circ\text{C} \end{array} \right\} s_7 = 7.7642 \text{ kJ/kg} \cdot \text{K}$$

$$P_8 = 0.6 \text{ MPa} \left. \begin{array}{l} h_8 = 3310.2 \text{ kJ/kg} \\ s_8 = s_7 \end{array} \right\}$$

$$P_9 = 15 \text{ kPa} \left. \begin{array}{l} x_9 = \frac{s_9 - s_f}{s_{fg}} = \frac{7.7642 - 0.7549}{7.2522} = 0.9665 \\ s_9 = s_7 \end{array} \right\} h_9 = h_f + x_9 h_{fg} = 225.94 + (0.9665)(2372.3) = 2518.8 \text{ kJ/kg}$$

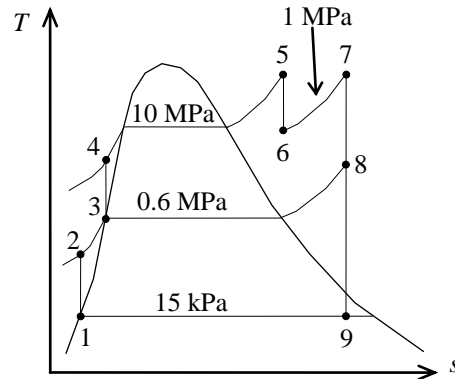
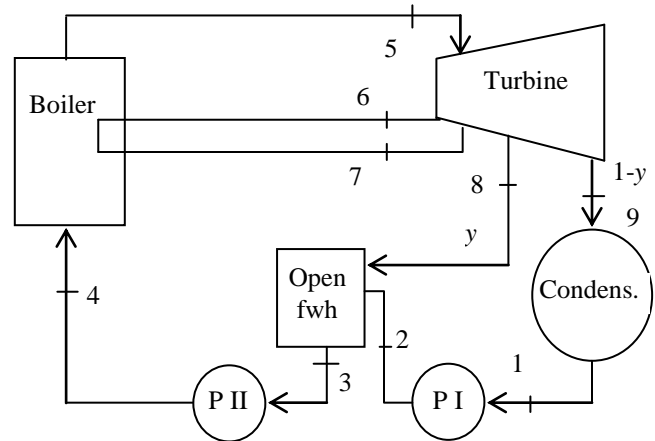

The fraction of steam extracted is determined from the steady-flow energy balance equation applied to the feedwater heaters. Noting that $\dot{Q} \cong \dot{W} \cong \Delta ke \cong \Delta pe \cong 0$,

$$\dot{E}_{\text{in}} - \dot{E}_{\text{out}} = \Delta \dot{E}_{\text{system}} \stackrel{\phi^0(\text{steady})}{=} 0 \rightarrow \dot{E}_{\text{in}} = \dot{E}_{\text{out}}$$

$$\sum \dot{m}_i h_i = \sum \dot{m}_e h_e \longrightarrow \dot{m}_8 h_8 + \dot{m}_2 h_2 = \dot{m}_3 h_3 \longrightarrow y h_8 + (1-y) h_2 = 1(h_3)$$

where y is the fraction of steam extracted from the turbine ($= \dot{m}_8 / \dot{m}_3$). Solving for y ,

$$y = \frac{h_3 - h_2}{h_8 - h_2} = \frac{670.38 - 226.53}{3310.2 - 226.53} = \mathbf{0.144}$$

(b) The thermal efficiency is determined from

$$q_{\text{in}} = (h_5 - h_4) + (h_7 - h_6) = (3375.1 - 680.73) + (3479.1 - 2783.8) = 3389.7 \text{ kJ/kg}$$

$$q_{\text{out}} = (1-y)(h_9 - h_1) = (1-0.144)(2518.8 - 225.94) = 1962.7 \text{ kJ/kg}$$

and $\eta_{\text{th}} = 1 - \frac{q_{\text{out}}}{q_{\text{in}}} = 1 - \frac{1962.7 \text{ kJ/kg}}{3389.7 \text{ kJ/kg}} = \mathbf{42.1\%}$

10-97 A nonideal reheat-regenerative Rankine cycle with one open feedwater heater is considered. The fraction of steam extracted for regeneration and the thermal efficiency of the cycle are to be determined.

Assumptions 1 Steady operating conditions exist. 2 Kinetic and potential energy changes are negligible.

Analysis

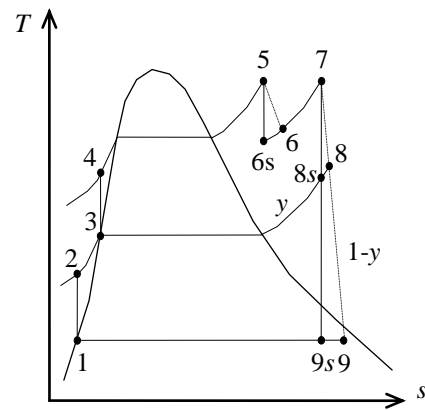
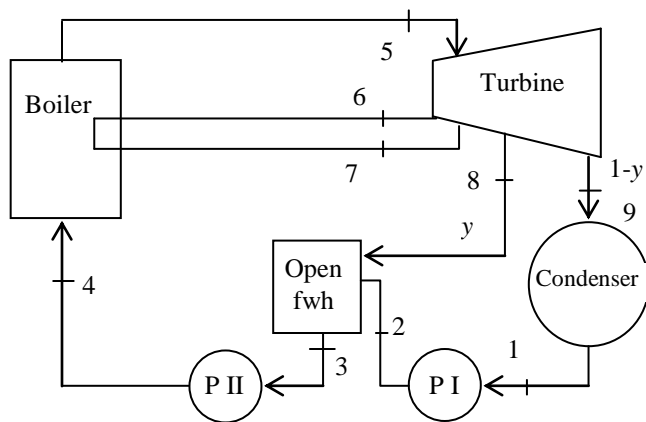

(a) From the steam tables (Tables A-4, A-5, and A-6),

$$h_1 = h_f @ 15 \text{ kPa} = 225.94 \text{ kJ/kg}$$

$$\nu_1 = \nu_f @ 15 \text{ kPa} = 0.001014 \text{ m}^3/\text{kg}$$

$$\begin{aligned} w_{pI, \text{in}} &= \nu_1 (P_2 - P_1) \\ &= (0.001014 \text{ m}^3/\text{kg})(600 - 15 \text{ kPa}) \left(\frac{1 \text{ kJ}}{1 \text{ kPa} \cdot \text{m}^3} \right) \\ &= 0.59 \text{ kJ/kg} \end{aligned}$$

$$h_2 = h_1 + w_{pI, \text{in}} = 225.94 + 0.59 = 226.54 \text{ kJ/kg}$$

$$\left. \begin{array}{l} P_3 = 0.6 \text{ MPa} \\ \text{sat. liquid} \end{array} \right\} \begin{array}{l} h_3 = h_f @ 0.6 \text{ MPa} = 670.38 \text{ kJ/kg} \\ \nu_3 = \nu_f @ 0.6 \text{ MPa} = 0.001101 \text{ m}^3/\text{kg} \end{array}$$

$$\begin{aligned} w_{pII, \text{in}} &= \nu_3 (P_4 - P_3) \\ &= (0.001101 \text{ m}^3/\text{kg})(10,000 - 600 \text{ kPa}) \left(\frac{1 \text{ kJ}}{1 \text{ kPa} \cdot \text{m}^3} \right) \\ &= 10.35 \text{ kJ/kg} \end{aligned}$$

$$h_4 = h_3 + w_{pII, \text{in}} = 670.38 + 10.35 = 680.73 \text{ kJ/kg}$$

$$\left. \begin{array}{l} P_5 = 10 \text{ MPa} \\ T_5 = 500^\circ\text{C} \end{array} \right\} \begin{array}{l} h_5 = 3375.1 \text{ kJ/kg} \\ s_5 = 6.5995 \text{ kJ/kg} \cdot \text{K} \end{array}$$

$$\left. \begin{array}{l} P_{6s} = 1.0 \text{ MPa} \\ s_{6s} = s_5 \end{array} \right\} h_{6s} = 2783.8 \text{ kJ/kg}$$

$$\begin{aligned} \eta_T &= \frac{h_5 - h_6}{h_5 - h_{6s}} \longrightarrow h_6 = h_5 - \eta_T (h_5 - h_{6s}) \\ &= 3375.1 - (0.84)(3375.1 - 2783.8) \\ &= 2878.4 \text{ kJ/kg} \end{aligned}$$

$$\left. \begin{array}{l} P_7 = 1.0 \text{ MPa} \\ T_7 = 500^\circ\text{C} \end{array} \right\} \begin{array}{l} h_7 = 3479.1 \text{ kJ/kg} \\ s_7 = 7.7642 \text{ kJ/kg} \cdot \text{K} \end{array}$$

$$\left. \begin{array}{l} P_{8s} = 0.6 \text{ MPa} \\ s_{8s} = s_7 \end{array} \right\} h_{8s} = 3310.2 \text{ kJ/kg}$$

$$\begin{aligned} \eta_T &= \frac{h_7 - h_8}{h_7 - h_{8s}} \longrightarrow h_8 = h_7 - \eta_T (h_7 - h_{8s}) = 3479.1 - (0.84)(3479.1 - 3310.2) \\ &= 3337.2 \text{ kJ/kg} \end{aligned}$$

$$P_{9s} = 15 \text{ kPa} \left\{ \begin{array}{l} x_{9s} = \frac{s_{9s} - s_f}{s_{fg}} = \frac{7.7642 - 0.7549}{7.2522} = 0.9665 \\ s_{9s} = s_7 \end{array} \right. \quad h_{9s} = h_f + x_{9s}h_{fg} = 225.94 + (0.9665)(2372.3) = 2518.8 \text{ kJ/kg}$$

$$\eta_T = \frac{h_7 - h_9}{h_7 - h_{9s}} \longrightarrow h_9 = h_7 - \eta_T(h_7 - h_{9s}) = 3479.1 - (0.84)(3479.1 - 2518.8) = 2672.5 \text{ kJ/kg}$$

The fraction of steam extracted is determined from the steady-flow energy balance equation applied to the feedwater heaters. Noting that $\dot{Q} \cong \dot{W} \cong \Delta ke \cong \Delta pe \cong 0$,

$$\begin{aligned} \dot{E}_{\text{in}} - \dot{E}_{\text{out}} &= \Delta \dot{E}_{\text{system}} \stackrel{\phi^0(\text{steady})}{=} 0 \\ \dot{E}_{\text{in}} &= \dot{E}_{\text{out}} \\ \sum \dot{m}_i h_i &= \sum \dot{m}_e h_e \longrightarrow \dot{m}_8 h_8 + \dot{m}_2 h_2 = \dot{m}_3 h_3 \longrightarrow y h_8 + (1 - y) h_2 = 1(h_3) \end{aligned}$$

where y is the fraction of steam extracted from the turbine ($= \dot{m}_8 / \dot{m}_3$). Solving for y ,

$$y = \frac{h_3 - h_2}{h_8 - h_2} = \frac{670.38 - 226.53}{3335.3 - 226.53} = \mathbf{0.1427}$$

(b) The thermal efficiency is determined from

$$\begin{aligned} q_{\text{in}} &= (h_5 - h_4) + (h_7 - h_6) \\ &= (3375.1 - 680.73) + (3479.1 - 2878.4) = 3295.1 \text{ kJ/kg} \\ q_{\text{out}} &= (1 - y)(h_9 - h_1) = (1 - 0.1427)(2672.5 - 225.94) = 2097.2 \text{ kJ/kg} \end{aligned}$$

and

$$\eta_{\text{th}} = 1 - \frac{q_{\text{out}}}{q_{\text{in}}} = 1 - \frac{2097.2 \text{ kJ/kg}}{3295.1 \text{ kJ/kg}} = \mathbf{36.4\%}$$

10-98 A cogeneration plant is to produce power and process heat. There are two turbines in the cycle: a high-pressure turbine and a low-pressure turbine. The temperature, pressure, and mass flow rate of steam at the inlet of high-pressure turbine are to be determined.

Assumptions 1 Steady operating conditions exist. 2 Kinetic and potential energy changes are negligible.

Analysis From the steam tables (Tables A-4, A-5, and A-6),

$$\begin{aligned}
 P_4 = 1.4 \text{ MPa} \left. \begin{array}{l} h_4 = h_g @ 1.4 \text{ MPa} = 2788.9 \text{ kJ/kg} \\ \text{sat. vapor} \end{array} \right\} s_4 = s_g @ 1.4 \text{ MPa} = 6.4675 \text{ kJ/kg} \cdot \text{K} \\
 x_{5s} = \frac{s_{4s} - s_f}{s_{fg}} = \frac{6.4675 - 0.6492}{7.4996} = 0.7758 \\
 P_5 = 10 \text{ kPa} \left. \begin{array}{l} h_{5s} = h_f + x_{5s} h_{fg} \\ s_{5s} = s_4 \end{array} \right\} \begin{aligned} &= 191.81 + (0.7758)(2392.1) \\ &= 2047.6 \text{ kJ/kg} \end{aligned} \\
 \eta_T = \frac{h_4 - h_5}{h_4 - h_{5s}} \longrightarrow h_5 = h_4 - \eta_T (h_4 - h_{5s}) \\
 = 2788.9 - (0.80)(2788.9 - 2047.6) \\
 = 2195.8 \text{ kJ/kg}
 \end{aligned}$$

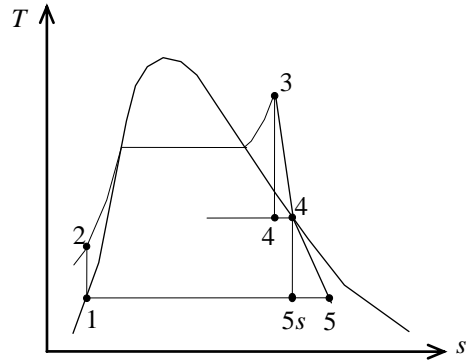

and

$$\begin{aligned}
 w_{\text{turb,low}} &= h_4 - h_5 = 2788.9 - 2195.8 = 593.0 \text{ kJ/kg} \\
 \dot{m}_{\text{lowturb}} &= \frac{\dot{W}_{\text{turb,II}}}{w_{\text{turb,low}}} = \frac{1500 \text{ kJ/s}}{593.0 \text{ kJ/kg}} = 2.529 \text{ kg/s} = 151.7 \text{ kg/min}
 \end{aligned}$$

Therefore ,

$$\begin{aligned}
 \dot{m}_{\text{total}} &= 1000 + 151.7 = 1152 \text{ kg/min} = \mathbf{19.20 \text{ kg/s}} \\
 w_{\text{turb,high}} &= \frac{\dot{W}_{\text{turb,I}}}{\dot{m}_{\text{high,turb}}} = \frac{5500 \text{ kJ/s}}{19.20 \text{ kg/s}} = 286.5 \text{ kJ/kg} = h_3 - h_4 \\
 h_3 &= w_{\text{turb,high}} + h_4 = 286.5 + 2788.9 = 3075.4 \text{ kJ/kg} \\
 \eta_T &= \frac{h_3 - h_4}{h_3 - h_{4s}} \longrightarrow h_{4s} = h_3 - (h_3 - h_4) / \eta_T \\
 &= 3075.4 - (3075.4 - 2788.9) / (0.85) \\
 &= 2738.3 \text{ kJ/kg} \\
 P_{4s} = 1.4 \text{ MPa} \left. \begin{array}{l} x_{4s} = \frac{h_{4s} - h_f}{h_{fg}} = \frac{2738.3 - 829.96}{1958.9} = 0.9742 \\ s_{4s} = s_3 \end{array} \right\} s_{4s} = s_f + x_{4s} s_{fg} = 2.2835 + (0.9742)(4.1840) = 6.3595 \text{ kJ/kg} \cdot \text{K}
 \end{aligned}$$

Then from the tables or the software, the turbine inlet temperature and pressure becomes

$$\begin{aligned}
 h_3 = 3075.4 \text{ kJ/kg} \left. \begin{array}{l} P_3 = \mathbf{6.40 \text{ MPa}} \\ s_3 = 6.3595 \text{ kJ/kg} \cdot \text{K} \end{array} \right\} T_3 = \mathbf{365^\circ\text{C}}
 \end{aligned}$$

10-99 A cogeneration plant is to generate power and process heat. Part of the steam extracted from the turbine at a relatively high pressure is used for process heating. The rate of process heat, the net power produced, and the utilization factor of the plant are to be determined.

Assumptions 1 Steady operating conditions exist. 2 Kinetic and potential energy changes are negligible.

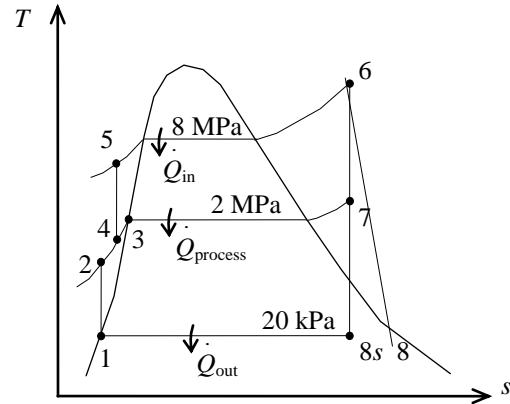
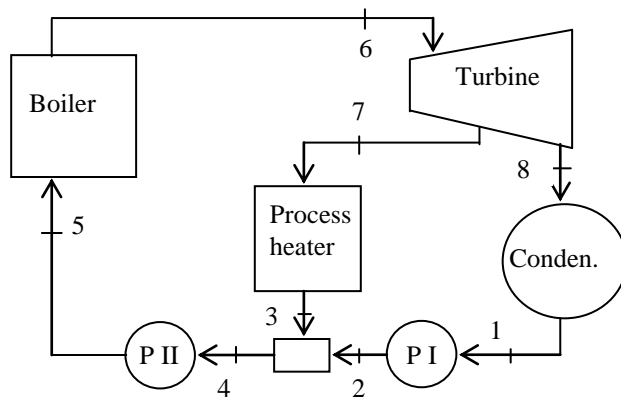

Analysis From the steam tables (Tables A-4, A-5, and A-6),

$$h_1 = h_f @ 20 \text{ kPa} = 251.42 \text{ kJ/kg}$$

$$\nu_1 = \nu_f @ 20 \text{ kPa} = 0.001017 \text{ m}^3/\text{kg}$$

$$\begin{aligned} w_{pI, \text{in}} &= \nu_1 (P_2 - P_1) / \eta_p \\ &= (0.001017 \text{ m}^3/\text{kg}) (2000 - 20 \text{ kPa}) \left(\frac{1 \text{ kJ}}{1 \text{ kPa} \cdot \text{m}^3} \right) / 0.88 \\ &= 2.29 \text{ kJ/kg} \end{aligned}$$

$$h_2 = h_1 + w_{pI, \text{in}} = 251.42 + 2.29 = 253.71 \text{ kJ/kg}$$

$$h_3 = h_f @ 2 \text{ MPa} = 908.47 \text{ kJ/kg}$$

Mixing chamber:

$$\dot{m}_3 h_3 + \dot{m}_2 h_2 = \dot{m}_4 h_4$$

$$(4 \text{ kg/s})(908.47 \text{ kJ/kg}) + (11 - 4 \text{ kg/s})(253.71 \text{ kJ/kg}) = (11 \text{ kg/s})h_4 \longrightarrow h_4 = 491.81 \text{ kJ/kg}$$

$$\nu_4 \cong \nu_f @ h_f = 491.81 \text{ kJ/kg} = 0.001058 \text{ m}^3/\text{kg}$$

$$\begin{aligned} w_{pII, \text{in}} &= \nu_4 (P_5 - P_4) / \eta_p \\ &= (0.001058 \text{ m}^3/\text{kg}) (8000 - 2000 \text{ kPa}) \left(\frac{1 \text{ kJ}}{1 \text{ kPa} \cdot \text{m}^3} \right) / 0.88 \\ &= 7.21 \text{ kJ/kg} \end{aligned}$$

$$h_5 = h_4 + w_{pII, \text{in}} = 491.81 + 7.21 = 499.02 \text{ kJ/kg}$$

$$\left. \begin{array}{l} P_6 = 8 \text{ MPa} \\ T_6 = 500^\circ\text{C} \end{array} \right\} \begin{array}{l} h_6 = 3399.5 \text{ kJ/kg} \\ s_6 = 6.7266 \text{ kJ/kg} \cdot \text{K} \end{array}$$

$$\left. \begin{array}{l} P_7 = 2 \text{ MPa} \\ s_7 = s_6 \end{array} \right\} h_{7s} = 3000.4 \text{ kJ/kg}$$

$$\eta_T = \frac{h_6 - h_7}{h_6 - h_{7s}} \longrightarrow h_7 = h_6 - \eta_T (h_6 - h_{7s}) = 3399.5 - (0.88)(3399.5 - 3000.4) = 3048.3 \text{ kJ/kg}$$

$$\left. \begin{array}{l} P_8 = 20 \text{ kPa} \\ s_8 = s_6 \end{array} \right\} h_{8s} = 2215.5 \text{ kJ/kg}$$

$$\eta_T = \frac{h_6 - h_8}{h_6 - h_{8s}} \longrightarrow h_8 = h_6 - \eta_T (h_6 - h_{8s}) = 3399.5 - (0.88)(3399.5 - 2215.5) = 2357.6 \text{ kJ/kg}$$

Then,

$$\dot{Q}_{\text{process}} = \dot{m}_7 (h_7 - h_3) = (4 \text{ kg/s})(3048.3 - 908.47) \text{ kJ/kg} = \mathbf{8559 \text{ kW}}$$

(b) Cycle analysis:

$$\begin{aligned} \dot{W}_{\text{T,out}} &= \dot{m}_7 (h_6 - h_7) + \dot{m}_8 (h_6 - h_8) \\ &= (4 \text{ kg/s})(3399.5 - 3048.3) \text{ kJ/kg} + (7 \text{ kg/s})(3399.5 - 2357.6) \text{ kJ/kg} \\ &= 8698 \text{ kW} \end{aligned}$$

$$\dot{W}_{\text{p,in}} = \dot{m}_1 w_{\text{pI,in}} + \dot{m}_4 w_{\text{pII,in}} = (7 \text{ kg/s})(2.29 \text{ kJ/kg}) + (11 \text{ kg/s})(7.21 \text{ kJ/kg}) = 95 \text{ kW}$$

$$\dot{W}_{\text{net}} = \dot{W}_{\text{T,out}} - \dot{W}_{\text{p,in}} = 8698 - 95 = \mathbf{8603 \text{ kW}}$$

(c) Then,

$$\dot{Q}_{\text{in}} = \dot{m}_5 (h_6 - h_5) = (11 \text{ kg/s})(3399.5 - 499.02) = 31,905 \text{ kW}$$

and

$$\varepsilon_u = \frac{\dot{W}_{\text{net}} + \dot{Q}_{\text{process}}}{\dot{Q}_{\text{in}}} = \frac{8603 + 8559}{31,905} = 0.538 = \mathbf{53.8\%}$$

10-100 A cogeneration power plant is modified with reheat and that produces 3 MW of power and supplies 7 MW of process heat. The rate of heat input in the boiler and the fraction of steam extracted for process heating are to be determined.

Assumptions 1 Steady operating conditions exist. 2 Kinetic and potential energy changes are negligible.

Analysis (a) From the steam tables (Tables A-4, A-5, and A-6),

$$h_1 = h_f @ 15 \text{ kPa} = 225.94 \text{ kJ/kg}$$

$$h_2 \cong h_1$$

$$h_3 = h_f @ 120^\circ\text{C} = 503.81 \text{ kJ/kg}$$

$$\left. \begin{array}{l} P_6 = 8 \text{ MPa} \\ T_6 = 500^\circ\text{C} \end{array} \right\} \begin{array}{l} h_6 = 3399.5 \text{ kJ/kg} \\ s_6 = 6.7266 \text{ kJ/kg} \cdot \text{K} \end{array}$$

$$\left. \begin{array}{l} P_7 = 1 \text{ MPa} \\ s_7 = s_6 \end{array} \right\} h_7 = 2843.7 \text{ kJ/kg}$$

$$\left. \begin{array}{l} P_8 = 1 \text{ MPa} \\ T_8 = 500^\circ\text{C} \end{array} \right\} \begin{array}{l} h_8 = 3479.1 \text{ kJ/kg} \\ s_8 = 7.7642 \text{ kJ/kg} \cdot \text{K} \end{array}$$

$$x_9 = \frac{s_9 - s_f}{s_{fg}} = \frac{7.7642 - 0.7549}{7.2522} = 0.9665$$

$$\left. \begin{array}{l} P_9 = 15 \text{ kPa} \\ s_9 = s_8 \end{array} \right\} \begin{array}{l} h_9 = h_f + x_9 h_{fg} = 225.94 + (0.9665)(2372.3) \\ = 2518.8 \text{ kJ/kg} \end{array}$$

The mass flow rate through the process heater is

$$\dot{m}_3 = \frac{\dot{Q}_{\text{process}}}{h_7 - h_3} = \frac{7,000 \text{ kJ/s}}{(2843.7 - 503.81) \text{ kJ/kg}} = 2.992 \text{ kg/s}$$

Also,

$$\dot{W}_T = \dot{m}_6(h_6 - h_7) + \dot{m}_9(h_8 - h_9) = \dot{m}_6(h_6 - h_7) + (\dot{m}_6 - 2.992)(h_8 - h_9)$$

$$3000 \text{ kJ/s} = \dot{m}_6(3399.5 - 2843.7) + (\dot{m}_6 - 2.992)(3479.1 - 2518.8)$$

It yields $\dot{m}_6 = 3.873 \text{ kg/s}$

and $\dot{m}_9 = \dot{m}_6 - \dot{m}_3 = 3.873 - 2.992 = 0.881 \text{ kg/s}$

Mixing chamber:

$$\dot{E}_{\text{in}} - \dot{E}_{\text{out}} = \Delta \dot{E}_{\text{system}} \stackrel{\text{no (steady)}}{=} 0$$

$$\dot{E}_{\text{in}} = \dot{E}_{\text{out}}$$

$$\sum \dot{m}_i h_i = \sum \dot{m}_e h_e \quad \longrightarrow \quad \dot{m}_4 h_4 = \dot{m}_2 h_2 + \dot{m}_3 h_3$$

$$\text{or, } h_4 \cong h_5 = \frac{\dot{m}_2 h_2 + \dot{m}_3 h_3}{\dot{m}_4} = \frac{(0.881)(225.94) + (2.992)(503.81)}{3.873} = 440.60 \text{ kJ/kg}$$

Then,

$$\begin{aligned} \dot{Q}_{\text{in}} &= \dot{m}_6(h_6 - h_5) + \dot{m}_9(h_8 - h_7) \\ &= (3.873 \text{ kg/s})(3399.5 - 440.60 \text{ kJ/kg}) + (0.881 \text{ kg/s})(3479.1 - 2843.7 \text{ kJ/kg}) \\ &= \mathbf{12,020 \text{ kW}} \end{aligned}$$

(b) The fraction of steam extracted for process heating is

$$y = \frac{\dot{m}_3}{\dot{m}_{\text{total}}} = \frac{2.992 \text{ kg/s}}{3.873 \text{ kg/s}} = \mathbf{77.3\%}$$

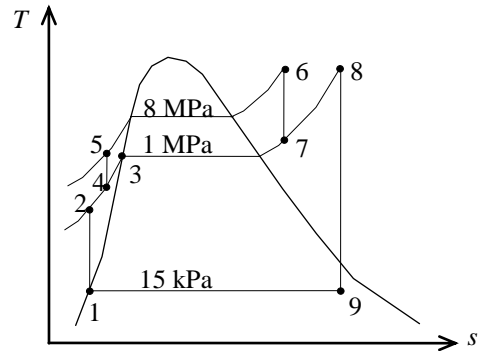
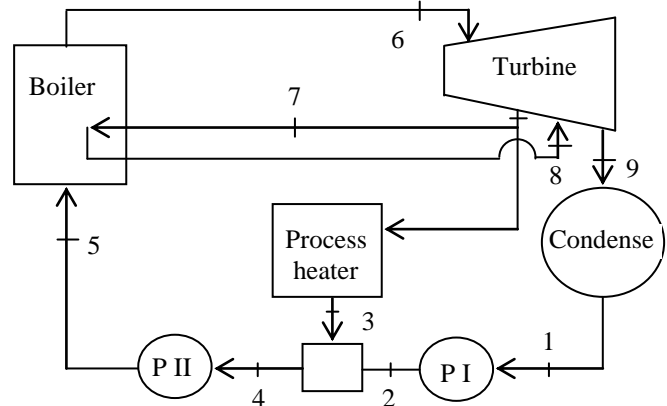

10-101E A combined gas-steam power cycle uses a simple gas turbine for the topping cycle and simple Rankine cycle for the bottoming cycle. The thermal efficiency of the cycle is to be determined.

Assumptions 1 Steady operating conditions exist. **2** The air-standard assumptions are applicable for Brayton cycle. **3** Kinetic and potential energy changes are negligible. **4** Air is an ideal gas with constant specific heats.

Properties The properties of air at room temperature are $c_p = 0.240$ Btu/lbm·R and $k = 1.4$ (Table A-2Ea).

Analysis Working around the topping cycle gives the following results:

$$T_{6s} = T_5 \left(\frac{P_6}{P_5} \right)^{(k-1)/k} = (540 \text{ R})(10)^{0.4/1.4} = 1043 \text{ R}$$

$$\eta_C = \frac{h_{6s} - h_5}{h_6 - h_5} = \frac{c_p(T_{6s} - T_5)}{c_p(T_6 - T_5)}$$

$$\begin{aligned} \longrightarrow T_6 &= T_5 + \frac{T_{6s} - T_5}{\eta_C} \\ &= 540 + \frac{1043 - 540}{0.90} = 1099 \text{ R} \end{aligned}$$

$$T_{8s} = T_7 \left(\frac{P_8}{P_7} \right)^{(k-1)/k} = (2560 \text{ R}) \left(\frac{1}{10} \right)^{0.4/1.4} = 1326 \text{ R}$$

$$\begin{aligned} \eta_T = \frac{h_7 - h_8}{h_7 - h_{8s}} = \frac{c_p(T_7 - T_8)}{c_p(T_7 - T_{8s})} &\longrightarrow T_8 = T_7 - \eta_T(T_7 - T_{8s}) \\ &= 2560 - (0.90)(2560 - 1326) \\ &= 1449 \text{ R} \end{aligned}$$

$$T_9 = T_{\text{sat @ 800 psia}} + 50 = 978.3 \text{ R} + 50 = 1028 \text{ R}$$

Fixing the states around the bottom steam cycle yields (Tables A-4E, A-5E, A-6E):

$$h_1 = h_f @ 5 \text{ psia} = 130.18 \text{ Btu/lbm}$$

$$v_1 = v_f @ 5 \text{ psia} = 0.01641 \text{ ft}^3/\text{lbm}$$

$$\begin{aligned} w_{p,\text{in}} &= v_1(P_2 - P_1) \\ &= (0.01641 \text{ ft}^3/\text{lbm})(800 - 5) \text{ psia} \left(\frac{1 \text{ Btu}}{5.404 \text{ psia} \cdot \text{ft}^3} \right) \\ &= 2.41 \text{ Btu/lbm} \end{aligned}$$

$$h_2 = h_1 + w_{p,\text{in}} = 130.18 + 2.41 = 132.59 \text{ Btu/lbm}$$

$$\left. \begin{array}{l} P_3 = 800 \text{ psia} \\ T_3 = 600^\circ\text{F} \end{array} \right\} \begin{array}{l} h_3 = 1270.9 \text{ Btu/lbm} \\ s_3 = 1.4866 \text{ Btu/lbm} \cdot \text{R} \end{array}$$

$$\left. \begin{array}{l} P_4 = 5 \text{ psia} \\ s_4 = s_3 \end{array} \right\} h_{4s} = 908.6 \text{ Btu/lbm}$$

$$\begin{aligned} \eta_T = \frac{h_3 - h_4}{h_3 - h_{4s}} &\longrightarrow h_4 = h_3 - \eta_T(h_3 - h_{4s}) \\ &= 1270.9 - (0.95)(1270.9 - 908.6) \\ &= 926.7 \text{ Btu/lbm} \end{aligned}$$

The net work outputs from each cycle are

$$\begin{aligned} w_{\text{net,gascycle}} &= w_{T,\text{out}} - w_{C,\text{in}} \\ &= c_p(T_7 - T_8) - c_p(T_6 - T_5) \\ &= (0.240 \text{ Btu/lbm} \cdot \text{R})(2560 - 1449 - 1099 + 540) \text{ R} \\ &= 132.5 \text{ Btu/lbm} \end{aligned}$$

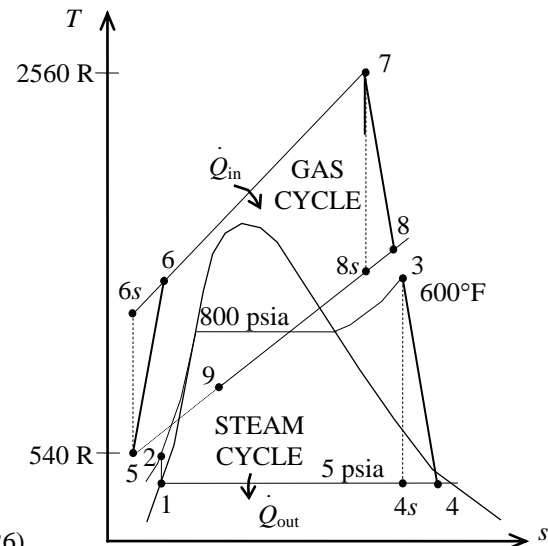

$$\begin{aligned}
 w_{\text{net, steam cycle}} &= w_{T,\text{out}} - w_{P,\text{in}} \\
 &= (h_3 - h_4) - w_{P,\text{in}} \\
 &= (1270.9 - 926.7) - 2.41 \\
 &= 341.8 \text{ Btu/lbm}
 \end{aligned}$$

An energy balance on the heat exchanger gives

$$\dot{m}_a c_p (T_8 - T_9) = \dot{m}_w (h_3 - h_2) \longrightarrow \dot{m}_w = \frac{c_p (T_8 - T_9)}{h_3 - h_2} \dot{m}_a = \frac{(0.240)(1449 - 1028)}{1270.9 - 132.59} = 0.08876 \dot{m}_a$$

That is, 1 lbm of exhaust gases can heat only 0.08876 lbm of water. Then the heat input, the heat output and the thermal efficiency are

$$\begin{aligned}
 q_{\text{in}} &= \frac{\dot{m}_a}{\dot{m}_a} c_p (T_7 - T_6) = (0.240 \text{ Btu/lbm} \cdot \text{R})(2560 - 1099)\text{R} = 350.6 \text{ Btu/lbm} \\
 q_{\text{out}} &= \frac{\dot{m}_a}{\dot{m}_a} c_p (T_9 - T_5) + \frac{\dot{m}_w}{\dot{m}_a} (h_4 - h_1) \\
 &= 1 \times (0.240 \text{ Btu/lbm} \cdot \text{R})(1028 - 540)\text{R} + 0.08876 \times (926.7 - 130.18) \text{ Btu/lbm} \\
 &= 187.8 \text{ Btu/lbm} \\
 \eta_{\text{th}} &= 1 - \frac{q_{\text{out}}}{q_{\text{in}}} = 1 - \frac{187.8}{350.6} = \mathbf{0.4643}
 \end{aligned}$$

10-102E A combined gas-steam power cycle uses a simple gas turbine for the topping cycle and simple Rankine cycle for the bottoming cycle. The thermal efficiency of the cycle is to be determined.

Assumptions 1 Steady operating conditions exist. 2 The air-standard assumptions are applicable for Brayton cycle. 3 Kinetic and potential energy changes are negligible. 4 Air is an ideal gas with constant specific heats.

Properties The properties of air at room temperature are $c_p = 0.240 \text{ Btu/lbm}\cdot\text{R}$ and $k = 1.4$ (Table A-2Ea).

Analysis Working around the topping cycle gives the following results:

$$T_{6s} = T_5 \left(\frac{P_6}{P_5} \right)^{(k-1)/k} = (540 \text{ R})(10)^{0.4/1.4} = 1043 \text{ R}$$

$$\eta_C = \frac{h_{6s} - h_5}{h_6 - h_5} = \frac{c_p(T_{6s} - T_5)}{c_p(T_6 - T_5)}$$

$$\begin{aligned} \longrightarrow T_6 &= T_5 + \frac{T_{6s} - T_5}{\eta_C} \\ &= 540 + \frac{1043 - 540}{0.90} = 1099 \text{ R} \end{aligned}$$

$$T_{8s} = T_7 \left(\frac{P_8}{P_7} \right)^{(k-1)/k} = (2560 \text{ R}) \left(\frac{1}{10} \right)^{0.4/1.4} = 1326 \text{ R}$$

$$\begin{aligned} \eta_T &= \frac{h_7 - h_8}{h_7 - h_{8s}} = \frac{c_p(T_7 - T_8)}{c_p(T_7 - T_{8s})} \longrightarrow T_8 = T_7 - \eta_T(T_7 - T_{8s}) \\ &= 2560 - (0.90)(2560 - 1326) \\ &= 1449 \text{ R} \end{aligned}$$

$$T_9 = T_{\text{sat}@800\text{psia}} + 50 = 978.3 \text{ R} + 50 = 1028 \text{ R}$$

Fixing the states around the bottom steam cycle yields (Tables A-4E, A-5E, A-6E):

$$h_1 = h_f @ 10 \text{ psia} = 161.25 \text{ Btu/lbm}$$

$$v_1 = v_f @ 10 \text{ psia} = 0.01659 \text{ ft}^3/\text{lbm}$$

$$\begin{aligned} w_{p,\text{in}} &= v_1(P_2 - P_1) \\ &= (0.01659 \text{ ft}^3/\text{lbm})(800 - 10) \text{ psia} \left(\frac{1 \text{ Btu}}{5.404 \text{ psia}\cdot\text{ft}^3} \right) \\ &= 2.43 \text{ Btu/lbm} \end{aligned}$$

$$h_2 = h_1 + w_{p,\text{in}} = 161.25 + 2.43 = 163.7 \text{ Btu/lbm}$$

$$\left. \begin{array}{l} P_3 = 800 \text{ psia} \\ T_3 = 600^\circ\text{F} \end{array} \right\} \begin{array}{l} h_3 = 1270.9 \text{ Btu/lbm} \\ s_3 = 1.4866 \text{ Btu/lbm}\cdot\text{R} \end{array}$$

$$\left. \begin{array}{l} P_4 = 10 \text{ psia} \\ s_4 = s_3 \end{array} \right\} h_{4s} = 946.6 \text{ Btu/lbm}$$

$$\begin{aligned} \eta_T &= \frac{h_3 - h_4}{h_3 - h_{4s}} \longrightarrow h_4 = h_3 - \eta_T(h_3 - h_{4s}) \\ &= 1270.9 - (0.95)(1270.9 - 946.6) \\ &= 962.8 \text{ Btu/lbm} \end{aligned}$$

The net work outputs from each cycle are

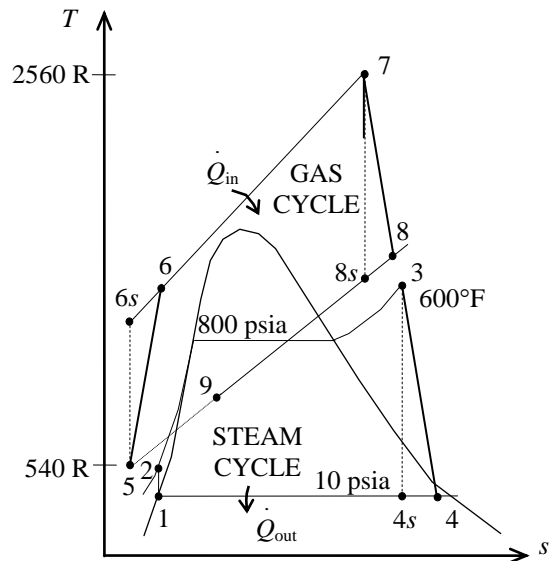

$$\begin{aligned}
 w_{\text{net, gas cycle}} &= w_{T,\text{out}} - w_{C,\text{in}} \\
 &= c_p (T_7 - T_8) - c_p (T_6 - T_5) \\
 &= (0.240 \text{ Btu/lbm} \cdot \text{R})(2560 - 1449 - 1099 + 540)\text{R} \\
 &= 132.5 \text{ Btu/lbm}
 \end{aligned}$$

$$\begin{aligned}
 w_{\text{net, steam cycle}} &= w_{T,\text{out}} - w_{P,\text{in}} \\
 &= (h_3 - h_4) - w_{P,\text{in}} \\
 &= (1270.9 - 962.8) - 2.43 \\
 &= 305.7 \text{ Btu/lbm}
 \end{aligned}$$

An energy balance on the heat exchanger gives

$$\dot{m}_a c_p (T_8 - T_9) = \dot{m}_w (h_3 - h_2) \longrightarrow \dot{m}_w = \frac{c_p (T_8 - T_9)}{h_3 - h_2} \dot{m}_a = \frac{(0.240)(1449 - 1028)}{1270.9 - 163.7} = 0.09126 \dot{m}_a$$

That is, 1 lbm of exhaust gases can heat only 0.09126 lbm of water. Then the heat input, the heat output and the thermal efficiency are

$$\begin{aligned}
 q_{\text{in}} &= \frac{\dot{m}_a}{\dot{m}_a} c_p (T_7 - T_6) = (0.240 \text{ Btu/lbm} \cdot \text{R})(2560 - 1099)\text{R} = 350.6 \text{ Btu/lbm} \\
 q_{\text{out}} &= \frac{\dot{m}_a}{\dot{m}_a} c_p (T_9 - T_5) + \frac{\dot{m}_w}{\dot{m}_a} (h_4 - h_1) \\
 &= 1 \times (0.240 \text{ Btu/lbm} \cdot \text{R})(1028 - 540)\text{R} + 0.09126 \times (962.8 - 161.25) \text{ Btu/lbm} \\
 &= 190.3 \text{ Btu/lbm} \\
 \eta_{\text{th}} &= 1 - \frac{q_{\text{out}}}{q_{\text{in}}} = 1 - \frac{190.3}{350.6} = \mathbf{0.4573}
 \end{aligned}$$

When the condenser pressure is increased from 5 psia to 10 psia, the thermal efficiency is decreased from 0.4643 to 0.4573.

10-103E A combined gas-steam power cycle uses a simple gas turbine for the topping cycle and simple Rankine cycle for the bottoming cycle. The cycle supplies a specified rate of heat to the buildings during winter. The mass flow rate of air and the net power output from the cycle are to be determined.

Assumptions 1 Steady operating conditions exist. 2 The air-standard assumptions are applicable to Brayton cycle. 3 Kinetic and potential energy changes are negligible. 4 Air is an ideal gas with constant specific heats.

Properties The properties of air at room temperature are $c_p = 0.240 \text{ Btu/lbm}\cdot\text{R}$ and $k = 1.4$ (Table A-2Ea).

Analysis The mass flow rate of water is

$$\dot{m}_w = \frac{\dot{Q}_{\text{buildings}}}{h_4 - h_1} = \frac{2 \times 10^6 \text{ Btu/h}}{(962.8 - 161.25) \text{ Btu/lbm}} = 2495 \text{ lbm/h}$$

The mass flow rate of air is then

$$\dot{m}_a = \frac{\dot{m}_w}{0.09126} = \frac{2495}{0.09126} = \mathbf{27,340 \text{ lbm/h}}$$

The power outputs from each cycle are

$$\begin{aligned} \dot{W}_{\text{net, gas cycle}} &= \dot{m}_a (w_{T,\text{out}} - w_{C,\text{in}}) \\ &= \dot{m}_a c_p (T_7 - T_8) - \dot{m}_a c_p (T_6 - T_5) \\ &= (27,340 \text{ lbm/h})(0.240 \text{ Btu/lbm}\cdot\text{R})(2560 - 1449 - 1099 + 540) \text{ R} \left(\frac{1 \text{ kW}}{3412.14 \text{ Btu/h}} \right) \\ &= 1062 \text{ kW} \end{aligned}$$

$$\begin{aligned} \dot{W}_{\text{net, steam cycle}} &= \dot{m}_a (w_{T,\text{out}} - w_{P,\text{in}}) \\ &= \dot{m}_a (h_3 - h_4 - w_{P,\text{in}}) \\ &= (2495 \text{ lbm/h})(1270.9 - 962.8 - 2.43) \left(\frac{1 \text{ kW}}{3412.14 \text{ Btu/h}} \right) \\ &= 224 \text{ kW} \end{aligned}$$

The net electricity production by this cycle is then

$$\dot{W}_{\text{net}} = 1062 + 224 = \mathbf{1286 \text{ kW}}$$

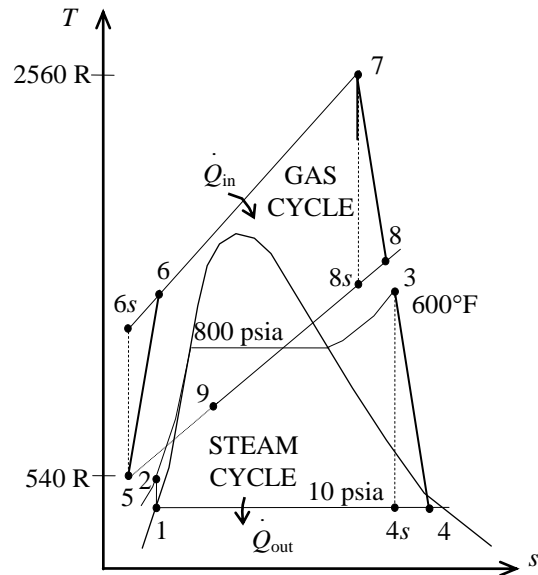

10-104 A combined gas-steam power plant is considered. The topping cycle is an ideal gas-turbine cycle and the bottoming cycle is an ideal reheat Rankine cycle. The mass flow rate of air in the gas-turbine cycle, the rate of total heat input, and the thermal efficiency of the combined cycle are to be determined.

Assumptions 1 Steady operating conditions exist. **2** Kinetic and potential energy changes are negligible. **3** Air is an ideal gas with variable specific heats.

Analysis (a) The analysis of gas cycle yields

$$T_7 = 310 \text{ K} \longrightarrow h_7 = 310.24 \text{ kJ/kg}$$

$$P_{r_7} = 1.5546$$

$$P_{r_8} = \frac{P_8}{P_7} P_{r_7} = (12)(1.5546) = 18.66 \longrightarrow h_8 = 630.18 \text{ kJ/kg}$$

$$T_9 = 1400 \text{ K} \longrightarrow h_9 = 1515.42 \text{ kJ/kg}$$

$$P_{r_9} = 450.5$$

$$P_{r_{10}} = \frac{P_{10}}{P_9} P_{r_9} = \left(\frac{1}{12}\right)(450.5) = 37.54 \longrightarrow h_{10} = 768.38 \text{ kJ/kg}$$

$$T_{11} = 520 \text{ K} \longrightarrow h_{11} = 523.63 \text{ kJ/kg}$$

From the steam tables (Tables A-4, A-5, and A-6),

$$h_1 = h_f @ 10 \text{ kPa} = 191.81 \text{ kJ/kg}$$

$$v_1 = v_f @ 10 \text{ kPa} = 0.00101 \text{ m}^3/\text{kg}$$

$$w_{p,\text{in}} = v_1(P_2 - P_1) = (0.00101 \text{ m}^3/\text{kg})(12,500 - 10 \text{ kPa}) \left(\frac{1 \text{ kJ}}{1 \text{ kPa} \cdot \text{m}^3}\right) = 12.62 \text{ kJ/kg}$$

$$h_2 = h_1 + w_{p,\text{in}} = 191.81 + 12.62 = 204.42 \text{ kJ/kg}$$

$$\left. \begin{array}{l} P_3 = 12.5 \text{ MPa} \\ T_3 = 500^\circ\text{C} \end{array} \right\} \begin{array}{l} h_3 = 3343.6 \text{ kJ/kg} \\ s_3 = 6.4651 \text{ kJ/kg} \cdot \text{K} \end{array}$$

$$\left. \begin{array}{l} P_4 = 2.5 \text{ MPa} \\ s_4 = s_3 \end{array} \right\} h_4 = 2909.6 \text{ kJ/kg}$$

$$\left. \begin{array}{l} P_5 = 2.5 \text{ MPa} \\ T_5 = 550^\circ\text{C} \end{array} \right\} \begin{array}{l} h_5 = 3574.4 \text{ kJ/kg} \\ s_5 = 7.4653 \text{ kJ/kg} \cdot \text{K} \end{array}$$

$$\left. \begin{array}{l} P_6 = 10 \text{ kPa} \\ s_6 = s_5 \end{array} \right\} \begin{array}{l} x_6 = \frac{s_6 - s_f}{s_{fg}} = \frac{7.4653 - 0.6492}{7.4996} = 0.9089 \\ h_6 = h_f + x_6 h_{fg} = 191.81 + (0.9089)(2392.1) = 2365.8 \text{ kJ/kg} \end{array}$$

Noting that $\dot{Q} \cong \dot{W} \cong \Delta ke \cong \Delta pe \cong 0$ for the heat exchanger, the steady-flow energy balance equation yields

$$\dot{E}_{\text{in}} = \dot{E}_{\text{out}} \longrightarrow \sum \dot{m}_i h_i = \sum \dot{m}_e h_e \longrightarrow \dot{m}_s (h_3 - h_2) = \dot{m}_{\text{air}} (h_{10} - h_{11})$$

$$\dot{m}_{\text{air}} = \frac{h_3 - h_2}{h_{10} - h_{11}} \dot{m}_s = \frac{3343.6 - 204.42}{768.38 - 523.63} (12 \text{ kg/s}) = \mathbf{153.9 \text{ kg/s}}$$

(b) The rate of total heat input is

$$\begin{aligned} \dot{Q}_{\text{in}} &= \dot{Q}_{\text{air}} + \dot{Q}_{\text{reheat}} = \dot{m}_{\text{air}} (h_9 - h_8) + \dot{m}_{\text{reheat}} (h_5 - h_4) \\ &= (153.9 \text{ kg/s})(1515.42 - 630.18) \text{ kJ/kg} + (12 \text{ kg/s})(3574.4 - 2909.6) \text{ kJ/kg} \\ &= 144,200 \text{ kW} \\ &\cong \mathbf{1.44 \times 10^5 \text{ kW}} \end{aligned}$$

(c) The rate of heat rejection and the thermal efficiency are then

$$\begin{aligned} \dot{Q}_{\text{out}} &= \dot{Q}_{\text{out,air}} + \dot{Q}_{\text{out,steam}} = \dot{m}_{\text{air}} (h_{11} - h_7) + \dot{m}_s (h_6 - h_1) \\ &= (153.9 \text{ kg/s})(523.63 - 310.24) \text{ kJ/kg} + (12 \text{ kg/s})(2365.8 - 191.81) \text{ kJ/kg} \\ &= 58,930 \text{ kW} \end{aligned}$$

$$\eta_{\text{th}} = 1 - \frac{\dot{Q}_{\text{out}}}{\dot{Q}_{\text{in}}} = 1 - \frac{58,930 \text{ kW}}{144,200 \text{ kW}} = 0.5913 = \mathbf{59.1\%}$$

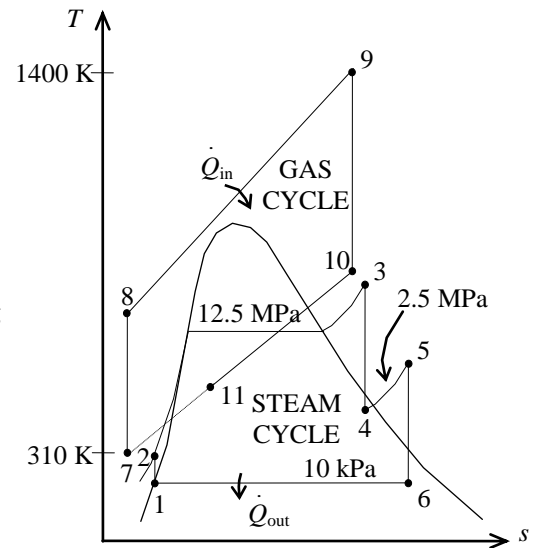

10-105 A combined gas-steam power plant is considered. The topping cycle is a gas-turbine cycle and the bottoming cycle is a nonideal reheat Rankine cycle. The mass flow rate of air in the gas-turbine cycle, the rate of total heat input, and the thermal efficiency of the combined cycle are to be determined.

Assumptions 1 Steady operating conditions exist. 2 Kinetic and potential energy changes are negligible. 3 Air is an ideal gas with variable specific heats.

Analysis (a) The analysis of gas cycle yields (Table A-17)

$$T_7 = 290 \text{ K} \longrightarrow h_7 = 290.16 \text{ kJ/kg}$$

$$P_{r_7} = 1.2311$$

$$P_{r_{8s}} = \frac{P_{8s}}{P_7} P_{r_7} = (8)(1.2311) = 9.849 \longrightarrow h_{8s} = 526.12 \text{ kJ/kg}$$

$$\eta_C = \frac{h_{8s} - h_7}{h_8 - h_7} \longrightarrow h_8 = h_7 + (h_{8s} - h_7)/\eta_C$$

$$= 290.16 + (526.12 - 290.16)/(0.85)$$

$$= 567.76 \text{ kJ/kg}$$

$$T_9 = 1400 \text{ K} \longrightarrow h_9 = 1515.42 \text{ kJ/kg}$$

$$P_{r_9} = 450.5$$

$$P_{r_{10s}} = \frac{P_{10s}}{P_9} P_{r_9} = \left(\frac{1}{8}\right)(450.5) = 56.3 \longrightarrow h_{10s} = 860.35 \text{ kJ/kg}$$

$$\eta_T = \frac{h_9 - h_{10}}{h_9 - h_{10s}} \longrightarrow h_{10} = h_9 - \eta_T(h_9 - h_{10s})$$

$$= 1515.42 - (0.90)(1515.42 - 860.35)$$

$$= 925.86 \text{ kJ/kg}$$

$$T_{11} = 520 \text{ K} \longrightarrow h_{11} = 523.63 \text{ kJ/kg}$$

From the steam tables (Tables A-4, A-5, and A-6),

$$h_1 = h_f @ 10 \text{ kPa} = 191.81 \text{ kJ/kg}$$

$$v_1 = v_f @ 10 \text{ kPa} = 0.00101 \text{ m}^3/\text{kg}$$

$$w_{p1,\text{in}} = v_1(P_2 - P_1)$$

$$= (0.00101 \text{ m}^3/\text{kg})(15,000 - 10 \text{ kPa}) \left(\frac{1 \text{ kJ}}{1 \text{ kPa} \cdot \text{m}^3} \right)$$

$$= 15.14 \text{ kJ/kg}$$

$$h_2 = h_1 + w_{p1,\text{in}} = 191.81 + 15.14 = 206.95 \text{ kJ/kg}$$

$$P_3 = 15 \text{ MPa} \left\{ \begin{array}{l} h_3 = 3157.9 \text{ kJ/kg} \\ s_3 = 6.1428 \text{ kJ/kg} \cdot \text{K} \end{array} \right.$$

$$P_4 = 3 \text{ MPa} \left\{ \begin{array}{l} x_{4s} = \frac{s_{4s} - s_f}{s_{fg}} = \frac{6.1434 - 2.6454}{3.5402} = 0.9880 \\ s_{4s} = s_3 \end{array} \right. \left\{ \begin{array}{l} h_{4s} = h_f + x_{4s} h_{fg} = 1008.3 + (0.9879)(1794.9) = 2781.7 \text{ kJ/kg} \end{array} \right.$$

$$\eta_T = \frac{h_3 - h_4}{h_3 - h_{4s}} \longrightarrow h_4 = h_3 - \eta_T(h_3 - h_{4s})$$

$$= 3157.9 - (0.90)(3157.9 - 2781.7)$$

$$= 2819.4 \text{ kJ/kg}$$

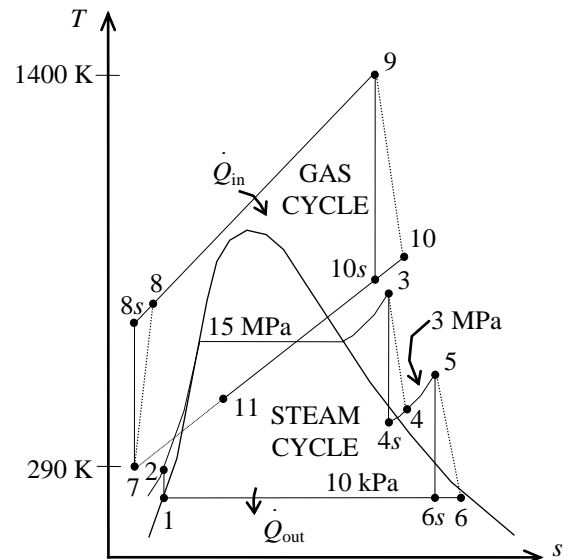

$$\left. \begin{array}{l} P_5 = 3 \text{ MPa} \\ T_5 = 500^\circ\text{C} \end{array} \right\} \begin{array}{l} h_5 = 3457.2 \text{ kJ/kg} \\ s_5 = 7.2359 \text{ kJ/kg} \cdot \text{K} \end{array}$$

$$\left. \begin{array}{l} P_6 = 10 \text{ kPa} \\ s_{6s} = s_5 \end{array} \right\} \begin{array}{l} x_{6s} = \frac{s_{6s} - s_f}{s_{fg}} = \frac{7.2359 - 0.6492}{7.4996} = 0.8783 \\ h_{6s} = h_f + x_{6s} h_{fg} = 191.81 + (0.8782)(2392.1) = 2292.7 \text{ kJ/kg} \end{array}$$

$$\eta_T = \frac{h_5 - h_6}{h_5 - h_{6s}} \longrightarrow h_6 = h_5 - \eta_T (h_5 - h_{6s}) \\ = 3457.2 - (0.90)(3457.2 - 2292.7) \\ = 2409.1 \text{ kJ/kg}$$

Noting that $\dot{Q} \cong \dot{W} \cong \Delta ke \cong \Delta pe \cong 0$ for the heat exchanger, the steady-flow energy balance equation yields

$$\begin{aligned} \dot{E}_{\text{in}} - \dot{E}_{\text{out}} &= \Delta \dot{E}_{\text{system}} \stackrel{\neq 0 \text{ (steady)}}{=} 0 \\ \dot{E}_{\text{in}} &= \dot{E}_{\text{out}} \\ \sum \dot{m}_i h_i &= \sum \dot{m}_e h_e \longrightarrow \dot{m}_s (h_3 - h_2) = \dot{m}_{\text{air}} (h_{10} - h_{11}) \\ \dot{m}_{\text{air}} &= \frac{h_3 - h_2}{h_{10} - h_{11}} \dot{m}_s = \frac{3157.9 - 206.95}{925.86 - 523.63} (30 \text{ kg/s}) = \mathbf{220.1 \text{ kg/s}} \end{aligned}$$

$$\begin{aligned} (b) \quad \dot{Q}_{\text{in}} &= \dot{Q}_{\text{air}} + \dot{Q}_{\text{reheat}} = \dot{m}_{\text{air}} (h_9 - h_8) + \dot{m}_{\text{reheat}} (h_5 - h_4) \\ &= (220.1 \text{ kg/s})(1515.42 - 567.76) \text{ kJ/kg} + (30 \text{ kg/s})(3457.2 - 2819.4) \text{ kJ/kg} \\ &= \mathbf{227,700 \text{ kW}} \end{aligned}$$

$$\begin{aligned} (c) \quad \dot{Q}_{\text{out}} &= \dot{Q}_{\text{out,air}} + \dot{Q}_{\text{out,steam}} = \dot{m}_{\text{air}} (h_{11} - h_7) + \dot{m}_s (h_6 - h_1) \\ &= (220.1 \text{ kg/s})(523.63 - 290.16) \text{ kJ/kg} + (30 \text{ kg/s})(2409.1 - 191.81) \text{ kJ/kg} \\ &= \mathbf{117,900 \text{ kW}} \end{aligned}$$

$$\eta_{\text{th}} = 1 - \frac{\dot{Q}_{\text{out}}}{\dot{Q}_{\text{in}}} = 1 - \frac{117,900 \text{ kW}}{227,700 \text{ kW}} = 0.482 = \mathbf{48.2\%}$$

10-106 A Rankine steam cycle modified with two closed feedwater heaters and one open feedwater heater is considered. The T - s diagram for the ideal cycle is to be sketched. The fraction of mass extracted for the open feedwater heater y and the cooling water flow temperature rise are to be determined. Also, the rate of heat rejected in the condenser and the thermal efficiency of the plant are to be determined.

Assumptions 1 Steady operating conditions exist. 2 Kinetic and potential energy changes are negligible.

Analysis (b) Using the data from the problem statement, the enthalpies at various states are

$$h_1 = h_f @ 20 \text{ kPa} = 251 \text{ kJ/kg}$$

$$h_{15} = h_3 = h_{14} = h_f @ 140 \text{ kPa} = 458 \text{ kJ/kg}$$

$$h_4 = h_f @ 620 \text{ kPa} = 676 \text{ kJ/kg}$$

$$h_6 = h_{12} = h_f @ 1910 \text{ kPa} = 898 \text{ kJ/kg}$$

An energy balance on the open feedwater heater gives

$$yh_9 + (1 - y)h_3 = 1h_4$$

where z is the fraction of steam extracted from the low-pressure turbine. Solving for z ,

$$y = \frac{h_4 - h_3}{h_9 - h_3} = \frac{676 - 458}{3154 - 458} = \mathbf{0.08086}$$

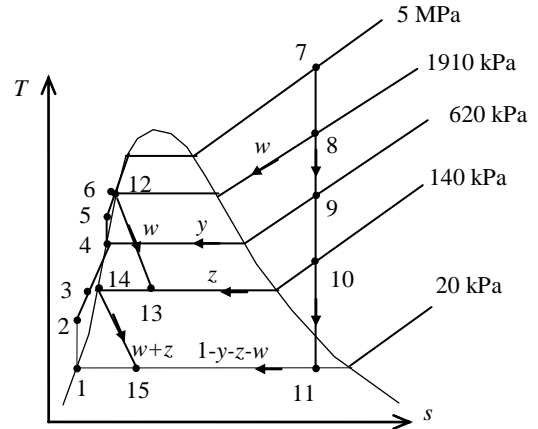

(c) An energy balance on the condenser gives

$$\dot{m}_7[(1 - w - y - z)h_{11} + (w + z)h_{15} - (1 - y)h_7] = \dot{m}_w(h_{w2} - h_{w1}) = \dot{m}_w c_{pw} \Delta T_w$$

Solving for the temperature rise of cooling water, and substituting with correct units,

$$\begin{aligned} \Delta T_w &= \frac{\dot{m}_7[(1 - w - y - z)h_{11} + (w + z)h_{15} - (1 - y)h_7]}{\dot{m}_w c_{pw}} \\ &= \frac{(100)[(1 - 0.0830 - 0.08086 - 0.0655)(2478) + (0.0830 + 0.0655)(458) - (1 - 0.08086)(251)]}{(4200)(4.18)} \\ &= \mathbf{9.95^\circ\text{C}} \end{aligned}$$

(d) The rate of heat rejected in the condenser is

$$\dot{Q}_{\text{out}} = \dot{m}_w c_{pw} \Delta T_w = (4200 \text{ kg/s})(4.18 \text{ kJ/kg} \cdot ^\circ\text{C})(9.95^\circ\text{C}) = \mathbf{174,700 \text{ kW}}$$

The rate of heat input in the boiler is

$$\dot{Q}_{\text{in}} = \dot{m}(h_7 - h_6) = (100 \text{ kg/s})(3900 - 898) \text{ kJ/kg} = 300,200 \text{ kW}$$

The thermal efficiency is then

$$\eta_{\text{th}} = 1 - \frac{\dot{Q}_{\text{out}}}{\dot{Q}_{\text{in}}} = 1 - \frac{174,700 \text{ kW}}{300,200 \text{ kW}} = 0.418 = \mathbf{41.8\%}$$

10-107 A steam power plant operates on an ideal reheat-regenerative Rankine cycle with one reheater and two feedwater heaters, one open and one closed. The fraction of steam extracted from the turbine for the open feedwater heater, the thermal efficiency of the cycle, and the net power output are to be determined.

Assumptions 1 Steady operating conditions exist. 2 Kinetic and potential energy changes are negligible.

Analysis

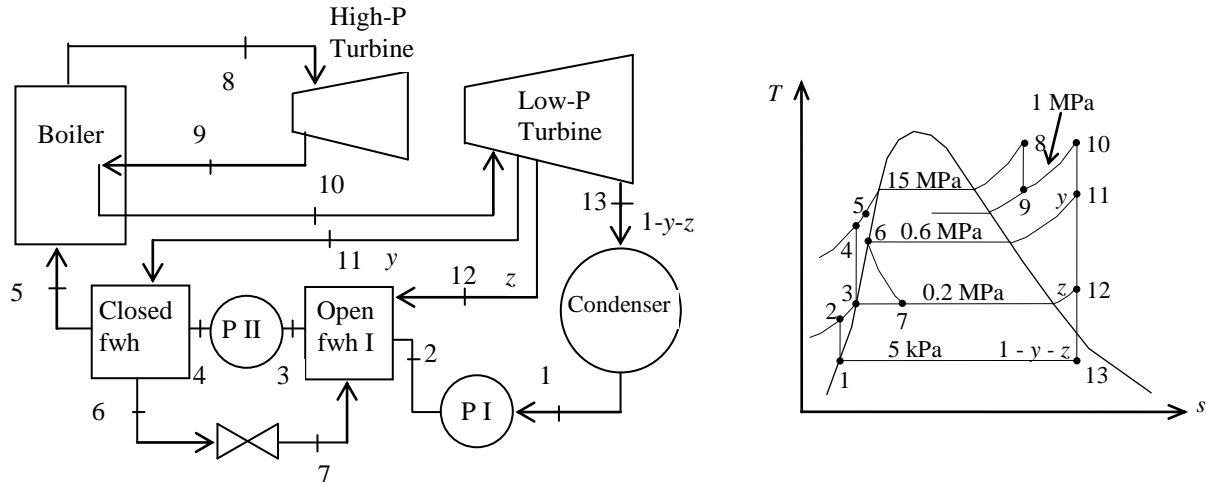

(a) From the steam tables (Tables A-4, A-5, and A-6),

$$h_1 = h_f @ 5 \text{ kPa} = 137.75 \text{ kJ/kg}$$

$$\nu_1 = \nu_f @ 5 \text{ kPa} = 0.001005 \text{ m}^3/\text{kg}$$

$$\begin{aligned} w_{pI, \text{in}} &= \nu_1 (P_2 - P_1) \\ &= (0.001005 \text{ m}^3/\text{kg})(200 - 5 \text{ kPa}) \left(\frac{1 \text{ kJ}}{1 \text{ kPa} \cdot \text{m}^3} \right) \\ &= 0.20 \text{ kJ/kg} \end{aligned}$$

$$h_2 = h_1 + w_{pI, \text{in}} = 137.75 + 0.20 = 137.95 \text{ kJ/kg}$$

$$\left. \begin{aligned} P_3 &= 0.2 \text{ MPa} \\ \text{sat. liquid} \end{aligned} \right\} \begin{aligned} h_3 &= h_f @ 0.2 \text{ MPa} = 504.71 \text{ kJ/kg} \\ \nu_3 &= \nu_f @ 0.2 \text{ MPa} = 0.001061 \text{ m}^3/\text{kg} \end{aligned}$$

$$\begin{aligned} w_{pII, \text{in}} &= \nu_3 (P_4 - P_3) \\ &= (0.001061 \text{ m}^3/\text{kg})(15,000 - 200 \text{ kPa}) \left(\frac{1 \text{ kJ}}{1 \text{ kPa} \cdot \text{m}^3} \right) \\ &= 15.70 \text{ kJ/kg} \end{aligned}$$

$$h_4 = h_3 + w_{pII, \text{in}} = 504.71 + 15.70 = 520.41 \text{ kJ/kg}$$

$$\left. \begin{aligned} P_6 &= 0.6 \text{ MPa} \\ \text{sat. liquid} \end{aligned} \right\} \begin{aligned} h_6 = h_7 &= h_f @ 0.6 \text{ MPa} = 670.38 \text{ kJ/kg} \\ \nu_6 &= \nu_f @ 0.6 \text{ MPa} = 0.001101 \text{ m}^3/\text{kg} \end{aligned}$$

$$\begin{aligned} T_6 = T_5 &\longrightarrow h_5 = h_6 + \nu_6 (P_5 - P_6) \\ &= 670.38 + (0.001101 \text{ m}^3/\text{kg})(15,000 - 600 \text{ kPa}) \left(\frac{1 \text{ kJ}}{1 \text{ kPa} \cdot \text{m}^3} \right) \\ &= 686.23 \text{ kJ/kg} \end{aligned}$$

$$\left. \begin{aligned} P_8 &= 15 \text{ MPa} \\ T_8 &= 600^\circ\text{C} \end{aligned} \right\} \begin{aligned} h_8 &= 3583.1 \text{ kJ/kg} \\ s_8 &= 6.6796 \text{ kJ/kg} \cdot \text{K} \end{aligned}$$

$$\left. \begin{aligned} P_9 &= 1.0 \text{ MPa} \\ s_9 &= s_8 \end{aligned} \right\} h_9 = 2820.8 \text{ kJ/kg}$$

$$\left. \begin{aligned} P_{10} &= 1.0 \text{ MPa} \\ T_{10} &= 500^\circ\text{C} \end{aligned} \right\} \begin{aligned} h_{10} &= 3479.1 \text{ kJ/kg} \\ s_{10} &= 7.7642 \text{ kJ/kg} \cdot \text{K} \end{aligned}$$

$$P_{11} = 0.6 \text{ MPa} \left. \vphantom{P_{11}} \right\} h_{11} = 3310.2 \text{ kJ/kg}$$

$$s_{11} = s_{10}$$

$$P_{12} = 0.2 \text{ MPa} \left. \vphantom{P_{12}} \right\} h_{12} = 3000.9 \text{ kJ/kg}$$

$$s_{12} = s_{10}$$

$$x_{13} = \frac{s_{13} - s_f}{s_{fg}} = \frac{7.7642 - 0.4762}{7.9176}$$

$$P_{13} = 5 \text{ kPa} \left. \vphantom{P_{13}} \right\} h_{13} = h_f + x_{13}h_{fg}$$

$$s_{13} = s_{10} \left. \vphantom{s_{13}} \right\} = 137.75 + (0.9205)(2423.0)$$

$$= 2368.1 \text{ kJ/kg}$$

The fraction of steam extracted is determined from the steady-flow energy balance equation applied to the feedwater heaters. Noting that $\dot{Q} \cong \dot{W} \cong \Delta ke \cong \Delta pe \cong 0$,

$$\dot{E}_{\text{in}} - \dot{E}_{\text{out}} = \Delta \dot{E}_{\text{system}}^{\phi^0(\text{steady})} = 0$$

$$\dot{E}_{\text{in}} = \dot{E}_{\text{out}}$$

$$\sum \dot{m}_i h_i = \sum \dot{m}_e h_e \longrightarrow \dot{m}_{11}(h_{11} - h_6) = \dot{m}_5(h_5 - h_4) \longrightarrow y(h_{11} - h_6) = (h_5 - h_4)$$

where y is the fraction of steam extracted from the turbine ($= \dot{m}_{11} / \dot{m}_5$). Solving for y ,

$$y = \frac{h_5 - h_4}{h_{11} - h_6} = \frac{686.23 - 520.41}{3310.2 - 670.38} = 0.06287$$

For the open FWH,

$$\dot{E}_{\text{in}} - \dot{E}_{\text{out}} = \Delta \dot{E}_{\text{system}}^{\phi^0(\text{steady})} = 0$$

$$\dot{E}_{\text{in}} = \dot{E}_{\text{out}}$$

$$\sum \dot{m}_i h_i = \sum \dot{m}_e h_e$$

$$\dot{m}_7 h_7 + \dot{m}_2 h_2 + \dot{m}_{12} h_{12} = \dot{m}_3 h_3$$

$$y h_7 + (1 - y - z) h_2 + z h_{12} = (1) h_3$$

where z is the fraction of steam extracted from the turbine ($= \dot{m}_{12} / \dot{m}_5$) at the second stage. Solving for z ,

$$z = \frac{(h_3 - h_2) - y(h_7 - h_2)}{h_{12} - h_2} = \frac{504.71 - 137.95 - (0.06287)(670.38 - 137.95)}{3000.0 - 137.95} = \mathbf{0.1165}$$

$$(b) \quad q_{\text{in}} = (h_8 - h_5) + (h_{10} - h_9)$$

$$= (3583.1 - 686.23) + (3479.1 - 2820.8) = 3555.3 \text{ kJ/kg}$$

$$q_{\text{out}} = (1 - y - z)(h_{13} - h_1) = (1 - 0.06287 - 0.1165)(2368.0 - 137.75) = 1830.4 \text{ kJ/kg}$$

$$w_{\text{net}} = q_{\text{in}} - q_{\text{out}} = 3555.3 - 1830.4 = 1724.9 \text{ kJ/kg}$$

and

$$\eta_{\text{th}} = 1 - \frac{q_{\text{out}}}{q_{\text{in}}} = 1 - \frac{1830.4 \text{ kJ/kg}}{3555.3 \text{ kJ/kg}} = \mathbf{48.5\%}$$

$$(c) \quad \dot{W}_{\text{net}} = \dot{m} w_{\text{net}} = (42 \text{ kg/s})(1724.9 \text{ kJ/kg}) = \mathbf{72,447 \text{ kW}}$$



10-108 The effect of the boiler pressure on the performance a simple ideal Rankine cycle is to be investigated.

Analysis The problem is solved using EES, and the solution is given below.

```

function x4$(x4) "this function returns a string to indicate the state of steam at point 4"
  x4$=""
  if (x4>1) then x4$='(superheated)'
  if (x4<0) then x4$='(compressed)'
end

{P[3] = 20000 [kPa]}
T[3] = 500 [C]
P[4] = 10 [kPa]
Eta_t = 1.0 "Turbine isentropic efficiency"
Eta_p = 1.0 "Pump isentropic efficiency"

"Pump analysis"
Fluid$='Steam_IAPWS'
P[1] = P[4]
P[2]=P[3]
x[1]=0 "Sat'd liquid"
h[1]=enthalpy(Fluid$,P=P[1],x=x[1])
v[1]=volume(Fluid$,P=P[1],x=x[1])
s[1]=entropy(Fluid$,P=P[1],x=x[1])
T[1]=temperature(Fluid$,P=P[1],x=x[1])
W_p_s=v[1]*(P[2]-P[1])"SSSF isentropic pump work assuming constant specific volume"
W_p=W_p_s/Eta_p
h[2]=h[1]+W_p "SSSF First Law for the pump"
s[2]=entropy(Fluid$,P=P[2],h=h[2])
T[2]=temperature(Fluid$,P=P[2],h=h[2])

"Turbine analysis"
h[3]=enthalpy(Fluid$,T=T[3],P=P[3])
s[3]=entropy(Fluid$,T=T[3],P=P[3])
s_s[4]=s[3]
hs[4]=enthalpy(Fluid$,s=s_s[4],P=P[4])
Ts[4]=temperature(Fluid$,s=s_s[4],P=P[4])
Eta_t=(h[3]-h[4])/(h[3]-hs[4])"Definition of turbine efficiency"
T[4]=temperature(Fluid$,P=P[4],h=h[4])
s[4]=entropy(Fluid$,h=h[4],P=P[4])
x[4]=quality(Fluid$,h=h[4],P=P[4])
h[3] =W_t+h[4] "SSSF First Law for the turbine"
x4s$=x4$(x[4])

"Boiler analysis"
Q_in + h[2]=h[3] "SSSF First Law for the Boiler"

"Condenser analysis"
h[4]=Q_out+h[1] "SSSF First Law for the Condenser"

"Cycle Statistics"
W_net=W_t-W_p
Eta_th=W_net/Q_in

```

η_{th}	W_{net} [kJ/kg]	x_4	P_3 [kPa]	Q_{in} [kJ/kg]	Q_{out} [kJ/kg]	W_p [kJ/kg]	W_t [kJ/kg]
0.2792	919.1	0.9921	500	3292	2373	0.495	919.6
0.3512	1147	0.886	2667	3266	2119	2.684	1150
0.3752	1216	0.8462	4833	3240	2024	4.873	1221
0.3893	1251	0.8201	7000	3213	1962	7.062	1258
0.399	1270	0.8001	9167	3184	1914	9.251	1280
0.406	1281	0.7835	11333	3155	1874	11.44	1292
0.4114	1286	0.769	13500	3125	1840	13.63	1299
0.4156	1286	0.756	15667	3094	1808	15.82	1302
0.4188	1283	0.744	17833	3062	1780	18.01	1301
0.4214	1276	0.7328	20000	3029	1753	20.2	1297

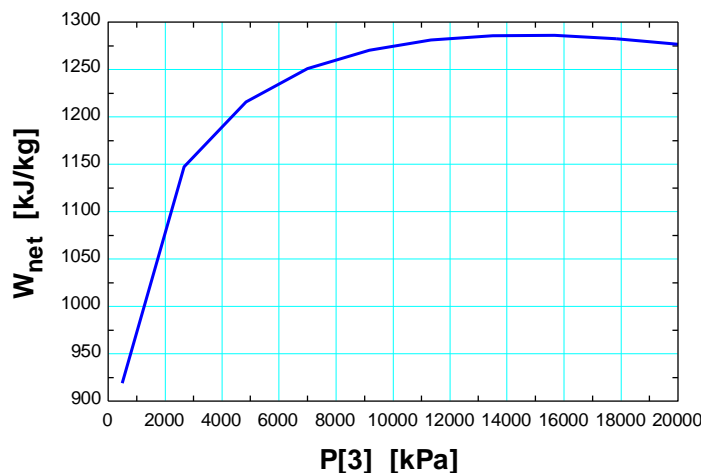
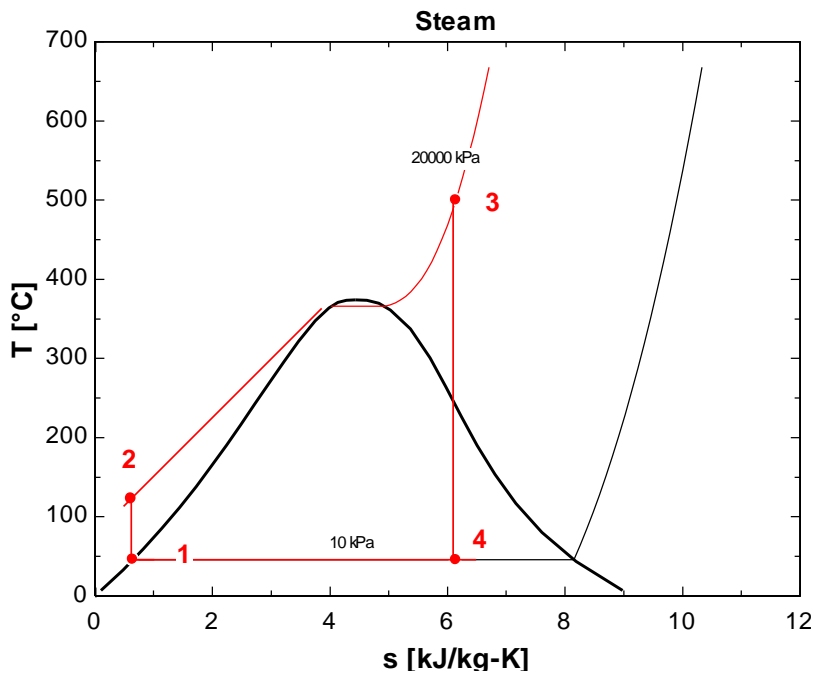

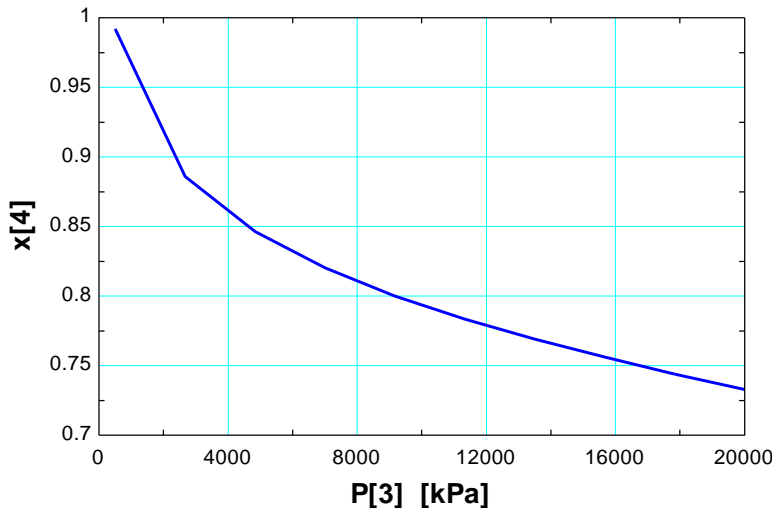
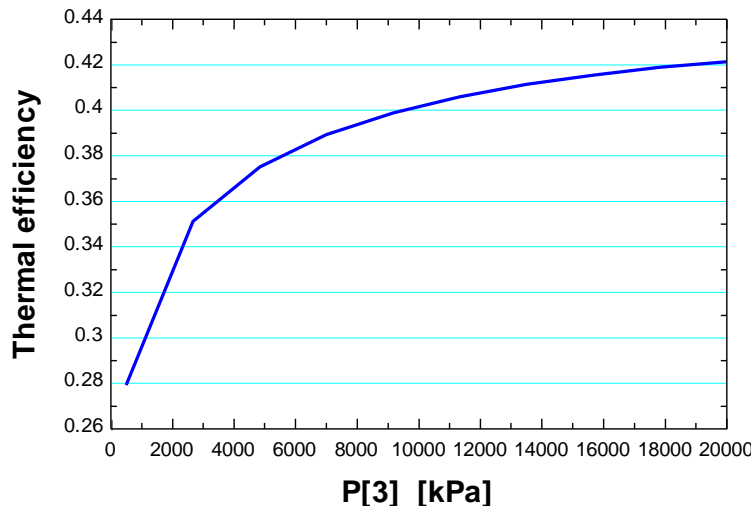



10-109 The effect of the condenser pressure on the performance a simple ideal Rankine cycle is to be investigated.

Analysis The problem is solved using EES, and the solution is given below.

```

function x4$(x4) "this function returns a string to indicate the state of steam at point 4"
  x4$=""
  if (x4>1) then x4$='(superheated)'
  if (x4<0) then x4$='(compressed)'
end

P[3] = 10000 [kPa]
T[3] = 550 [C]
"P[4] = 5 [kPa]"
Eta_t = 1.0 "Turbine isentropic efficiency"
Eta_p = 1.0 "Pump isentropic efficiency"

"Pump analysis"
Fluid$='Steam_IAPWS'
P[1] = P[4]
P[2]=P[3]
x[1]=0 "Sat'd liquid"
h[1]=enthalpy(Fluid$,P=P[1],x=x[1])
v[1]=volume(Fluid$,P=P[1],x=x[1])
s[1]=entropy(Fluid$,P=P[1],x=x[1])
T[1]=temperature(Fluid$,P=P[1],x=x[1])
W_p_s=v[1]*(P[2]-P[1])"SSSF isentropic pump work assuming constant specific volume"
W_p=W_p_s/Eta_p
h[2]=h[1]+W_p "SSSF First Law for the pump"
s[2]=entropy(Fluid$,P=P[2],h=h[2])
T[2]=temperature(Fluid$,P=P[2],h=h[2])

"Turbine analysis"
h[3]=enthalpy(Fluid$,T=T[3],P=P[3])
s[3]=entropy(Fluid$,T=T[3],P=P[3])
s_s[4]=s[3]
hs[4]=enthalpy(Fluid$,s=s_s[4],P=P[4])
Ts[4]=temperature(Fluid$,s=s_s[4],P=P[4])
Eta_t=(h[3]-h[4])/(h[3]-hs[4])"Definition of turbine efficiency"
T[4]=temperature(Fluid$,P=P[4],h=h[4])
s[4]=entropy(Fluid$,h=h[4],P=P[4])
x[4]=quality(Fluid$,h=h[4],P=P[4])
h[3] =W_t+h[4]"SSSF First Law for the turbine"
x4s=x4$(x[4])

"Boiler analysis"
Q_in + h[2]=h[3]"SSSF First Law for the Boiler"

"Condenser analysis"
h[4]=Q_out+h[1]"SSSF First Law for the Condenser"

"Cycle Statistics"
W_net=W_t-W_p
Eta_th=W_net/Q_in

```

P_4 [kPa]	η_{th}	W_{net} [kJ/kg]
5	0.4268	1432
15	0.3987	1302
25	0.3841	1237
35	0.3739	1192
45	0.3659	1157
55	0.3594	1129
65	0.3537	1105
75	0.3488	1084
85	0.3443	1065
100	0.3385	1040

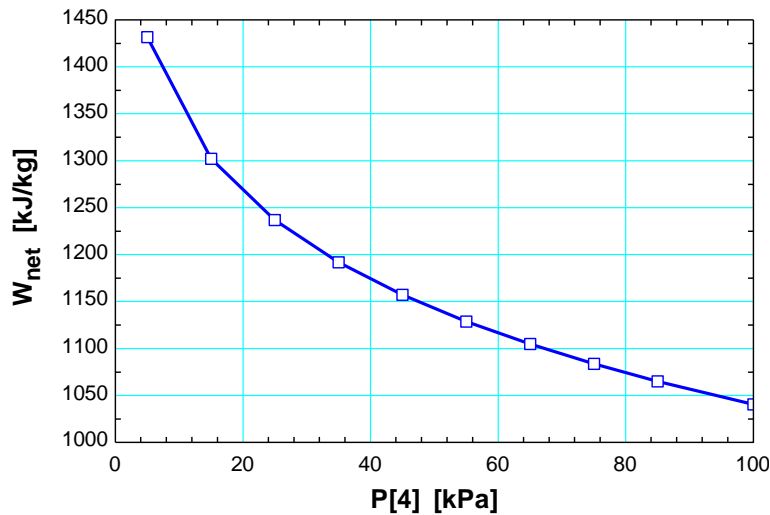
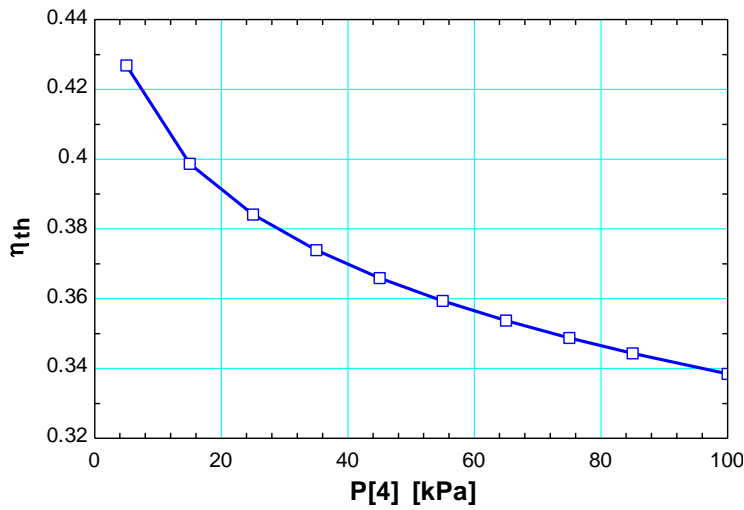
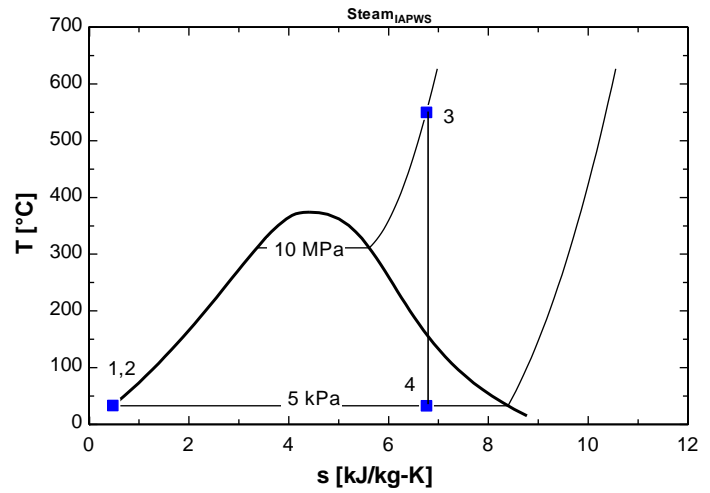



10-110 The effect of reheat pressure on the performance an ideal Rankine cycle is to be investigated.

Analysis The problem is solved using EES, and the solution is given below.

```
function x6$(x6) "this function returns a string to indicate the state of steam at point 6"
  x6$=""
  if (x6>1) then x6$='(superheated)'
  if (x6<0) then x6$='(subcooled)'
end

P[6] = 10 [kPa]
P[3] = 15000 [kPa]
T[3] = 500 [C]
"P[4] = 3000 [kPa]"
T[5] = 500 [C]
Eta_t = 100/100 "Turbine isentropic efficiency"
Eta_p = 100/100 "Pump isentropic efficiency"

"Pump analysis"
Fluid$='Steam_IAPWS'
P[1] = P[6]
P[2]=P[3]
x[1]=0 "Sat'd liquid"
h[1]=enthalpy(Fluid$,P=P[1],x=x[1])
v[1]=volume(Fluid$,P=P[1],x=x[1])
s[1]=entropy(Fluid$,P=P[1],x=x[1])
T[1]=temperature(Fluid$,P=P[1],x=x[1])
W_p_s=v[1]*(P[2]-P[1])"SSSF isentropic pump work assuming constant specific volume"
W_p=W_p_s/Eta_p
h[2]=h[1]+W_p "SSSF First Law for the pump"
v[2]=volume(Fluid$,P=P[2],h=h[2])
s[2]=entropy(Fluid$,P=P[2],h=h[2])
T[2]=temperature(Fluid$,P=P[2],h=h[2])

"High Pressure Turbine analysis"
h[3]=enthalpy(Fluid$,T=T[3],P=P[3])
s[3]=entropy(Fluid$,T=T[3],P=P[3])
v[3]=volume(Fluid$,T=T[3],P=P[3])
s_s[4]=s[3]
hs[4]=enthalpy(Fluid$,s=s_s[4],P=P[4])
Ts[4]=temperature(Fluid$,s=s_s[4],P=P[4])
Eta_t=(h[3]-h[4])/(h[3]-hs[4])"Definition of turbine efficiency"
T[4]=temperature(Fluid$,P=P[4],h=h[4])
s[4]=entropy(Fluid$,h=h[4],P=P[4])
v[4]=volume(Fluid$,s=s[4],P=P[4])
h[3] =W_t_hp+h[4]"SSSF First Law for the high pressure turbine"

"Low Pressure Turbine analysis"
P[5]=P[4]
s[5]=entropy(Fluid$,T=T[5],P=P[5])
h[5]=enthalpy(Fluid$,T=T[5],P=P[5])
s_s[6]=s[5]
hs[6]=enthalpy(Fluid$,s=s_s[6],P=P[6])
Ts[6]=temperature(Fluid$,s=s_s[6],P=P[6])
vs[6]=volume(Fluid$,s=s_s[6],P=P[6])
Eta_t=(h[5]-h[6])/(h[5]-hs[6])"Definition of turbine efficiency"
h[5]=W_t_lp+h[6]"SSSF First Law for the low pressure turbine"
x[6]=quality(Fluid$,h=h[6],P=P[6])

"Boiler analysis"
```

$$Q_{in} + h[2] + h[4] = h[3] + h[5] \text{ "SSSF First Law for the Boiler"}$$

"Condenser analysis"

$$h[6] = Q_{out} + h[1] \text{ "SSSF First Law for the Condenser"}$$

$$T[6] = \text{temperature}(\text{Fluid}, h=h[6], P=P[6])$$

$$s[6] = \text{entropy}(\text{Fluid}, h=h[6], P=P[6])$$

$$x6s = x6(x[6])$$

"Cycle Statistics"

$$W_{net} = W_{t_hp} + W_{t_lp} - W_p$$

$$\text{Eta}_{th} = W_{net} / Q_{in}$$

P_4 [kPa]	η_{th}	W_{net} [kJ/kg]	X_6
500	0.4128	1668	0.9921
1833	0.4253	1611	0.9102
3167	0.4283	1567	0.8747
4500	0.4287	1528	0.8511
5833	0.428	1492	0.8332
7167	0.4268	1458	0.8184
8500	0.4252	1426	0.8058
9833	0.4233	1395	0.7947
11167	0.4212	1366	0.7847
12500	0.4189	1337	0.7755

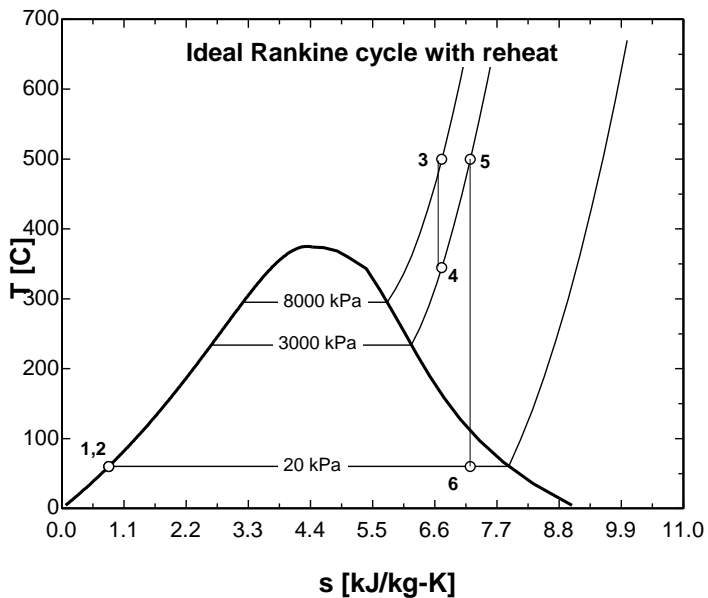

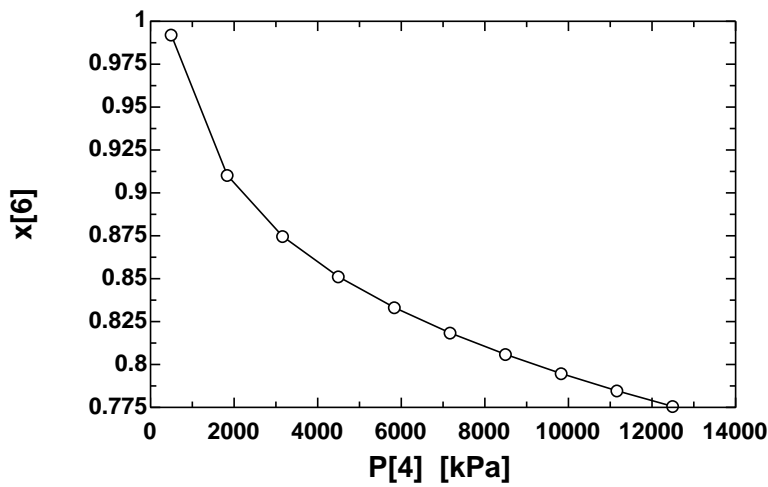
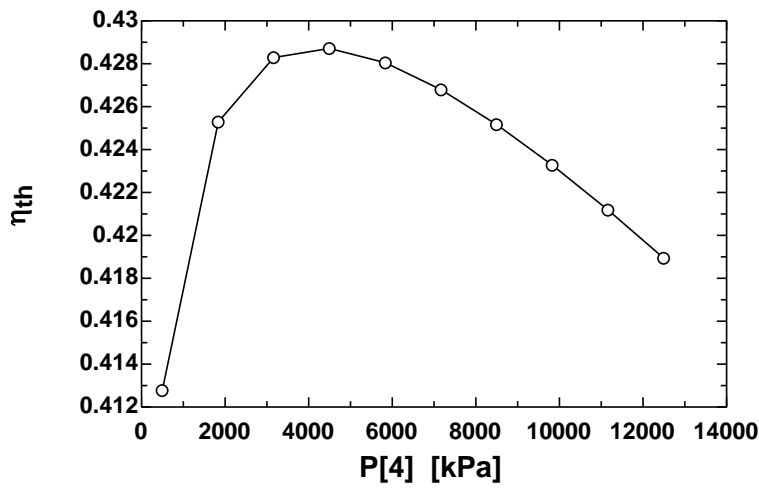
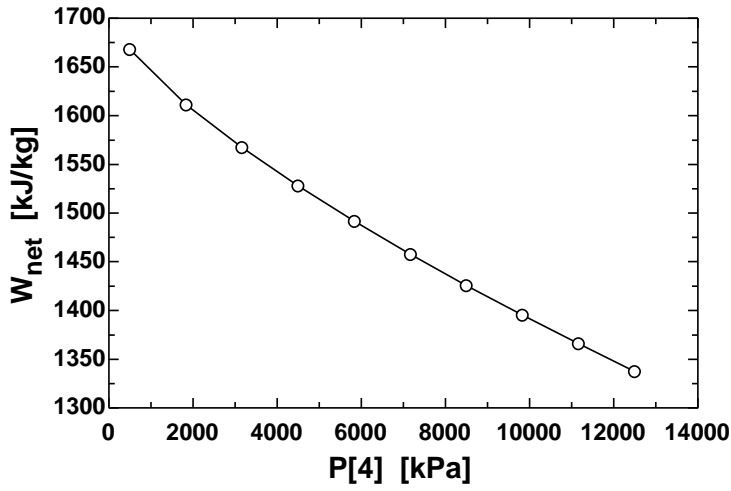



10-111 The effect of extraction pressure on the performance an ideal regenerative Rankine cycle with one open feedwater heater is to be investigated.

Analysis The problem is solved using EES, and the solution is given below.

"Input Data"

```
P[5] = 15000 [kPa]
T[5] = 600 [C]
P_extract=1400 [kPa]
P[6] = P_extract
P_cond=10 [kPa]
P[7] = P_cond
Eta_turb= 1.0 "Turbine isentropic efficiency"
Eta_pump = 1.0 "Pump isentropic efficiency"
P[1] = P[7]
P[2]=P[6]
P[3]=P[6]
P[4] = P[5]
```

"Condenser exit pump or Pump 1 analysis"

```
Fluid$='Steam_IAPWS'
h[1]=enthalpy(Fluid$,P=P[1],x=0) {Sat'd liquid}
v1=volume(Fluid$,P=P[1],x=0)
s[1]=entropy(Fluid$,P=P[1],x=0)
T[1]=temperature(Fluid$,P=P[1],x=0)
w_pump1_s=v1*(P[2]-P[1])"SSSF isentropic pump work assuming constant specific volume"
w_pump1=w_pump1_s/Eta_pump "Definition of pump efficiency"
h[1]+w_pump1= h[2] "Steady-flow conservation of energy"
s[2]=entropy(Fluid$,P=P[2],h=h[2])
T[2]=temperature(Fluid$,P=P[2],h=h[2])
```

"Open Feedwater Heater analysis:"

```
y*h[6] + (1- y)*h[2] = 1*h[3] "Steady-flow conservation of energy"
h[3]=enthalpy(Fluid$,P=P[3],x=0)
T[3]=temperature(Fluid$,P=P[3],x=0) "Condensate leaves heater as sat. liquid at P[3]"
s[3]=entropy(Fluid$,P=P[3],x=0)
```

"Boiler condensate pump or Pump 2 analysis"

```
v3=volume(Fluid$,P=P[3],x=0)
w_pump2_s=v3*(P[4]-P[3])"SSSF isentropic pump work assuming constant specific volume"
w_pump2=w_pump2_s/Eta_pump "Definition of pump efficiency"
h[3]+w_pump2= h[4] "Steady-flow conservation of energy"
s[4]=entropy(Fluid$,P=P[4],h=h[4])
T[4]=temperature(Fluid$,P=P[4],h=h[4])
```

"Boiler analysis"

```
q_in + h[4]=h[5]"SSSF conservation of energy for the Boiler"
h[5]=enthalpy(Fluid$, T=T[5], P=P[5])
s[5]=entropy(Fluid$, T=T[5], P=P[5])
```

"Turbine analysis"

```
ss[6]=s[5]
hs[6]=enthalpy(Fluid$,s=ss[6],P=P[6])
Ts[6]=temperature(Fluid$,s=ss[6],P=P[6])
h[6]=h[5]-Eta_turb*(h[5]-hs[6])"Definition of turbine efficiency for high pressure stages"
T[6]=temperature(Fluid$,P=P[6],h=h[6])
s[6]=entropy(Fluid$,P=P[6],h=h[6])
ss[7]=s[6]
hs[7]=enthalpy(Fluid$,s=ss[7],P=P[7])
Ts[7]=temperature(Fluid$,s=ss[7],P=P[7])
```

$h[7]=h[6]-\eta_{\text{turb}}*(h[6]-h_s[7])$ "Definition of turbine efficiency for low pressure stages"

$T[7]=\text{temperature}(\text{Fluid}\$,P=P[7],h=h[7])$

$s[7]=\text{entropy}(\text{Fluid}\$,P=P[7],h=h[7])$

$h[5]=y*h[6] + (1-y)*h[7] + w_{\text{turb}}$ "SSSF conservation of energy for turbine"

"Condenser analysis"

$(1-y)*h[7]=q_{\text{out}}+(1-y)*h[1]$ "SSSF First Law for the Condenser"

"Cycle Statistics"

$w_{\text{net}}=w_{\text{turb}} - ((1-y)*w_{\text{pump1}} + w_{\text{pump2}})$

$\eta_{\text{th}}=w_{\text{net}}/q_{\text{in}}$

η_{th}	P_{extract} [kPa]	w_{net} [kJ/kg]	q_{in} [kJ/kg]
0.4456	50	1438	3227
0.4512	100	1421	3150
0.4608	500	1349	2927
0.4629	1000	1298	2805
0.4626	2000	1230	2659
0.4562	5000	1102	2416
0.4511	7000	1040	2305
0.4434	10000	961.4	2168
0.4369	12500	903.5	2068

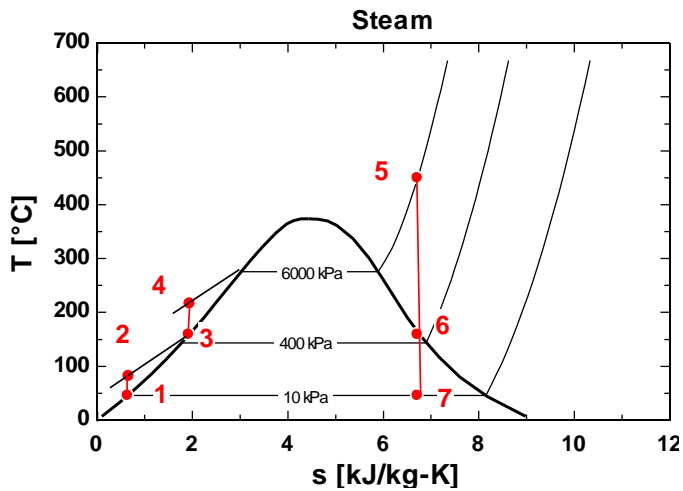

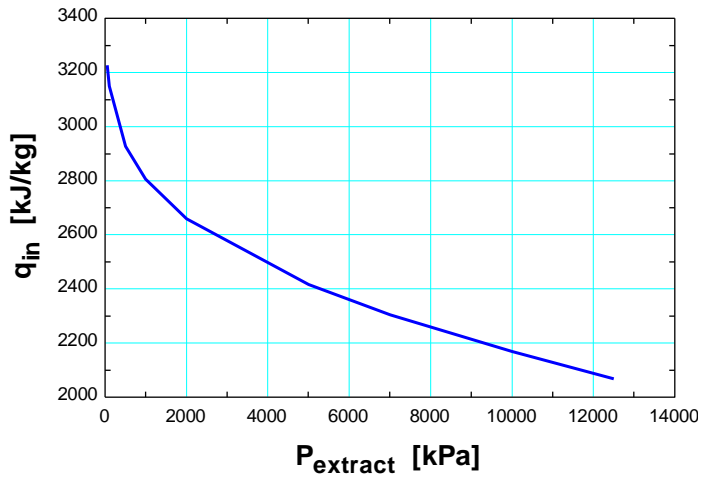
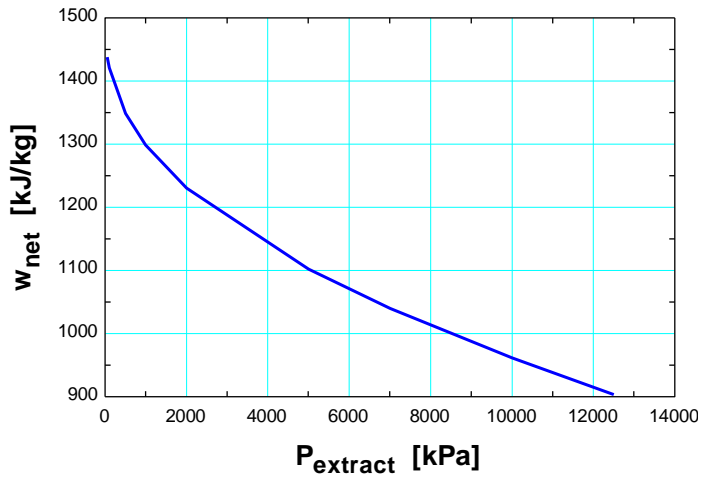

10-112 It is to be demonstrated that the thermal efficiency of a combined gas-steam power plant η_{cc} can be expressed as $\eta_{cc} = \eta_g + \eta_s - \eta_g \eta_s$ where $\eta_g = W_g / Q_{in}$ and $\eta_s = W_s / Q_{g,out}$ are the thermal efficiencies of the gas and steam cycles, respectively, and the efficiency of a combined cycle is to be obtained.

Analysis The thermal efficiencies of gas, steam, and combined cycles can be expressed as

$$\eta_{cc} = \frac{W_{total}}{Q_{in}} = 1 - \frac{Q_{out}}{Q_{in}}$$

$$\eta_g = \frac{W_g}{Q_{in}} = 1 - \frac{Q_{g,out}}{Q_{in}}$$

$$\eta_s = \frac{W_s}{Q_{g,out}} = 1 - \frac{Q_{out}}{Q_{g,out}}$$

where Q_{in} is the heat supplied to the gas cycle, where Q_{out} is the heat rejected by the steam cycle, and where $Q_{g,out}$ is the heat rejected from the gas cycle and supplied to the steam cycle.

Using the relations above, the expression $\eta_g + \eta_s - \eta_g \eta_s$ can be expressed as

$$\begin{aligned} \eta_g + \eta_s - \eta_g \eta_s &= \left(1 - \frac{Q_{g,out}}{Q_{in}}\right) + \left(1 - \frac{Q_{out}}{Q_{g,out}}\right) - \left(1 - \frac{Q_{g,out}}{Q_{in}}\right) \left(1 - \frac{Q_{out}}{Q_{g,out}}\right) \\ &= 1 - \frac{Q_{g,out}}{Q_{in}} + 1 - \frac{Q_{out}}{Q_{g,out}} - 1 + \frac{Q_{g,out}}{Q_{in}} + \frac{Q_{out}}{Q_{g,out}} - \frac{Q_{out}}{Q_{in}} \\ &= 1 - \frac{Q_{out}}{Q_{in}} \\ &= \eta_{cc} \end{aligned}$$

Therefore, the proof is complete. Using the relation above, the thermal efficiency of the given combined cycle is determined to be

$$\eta_{cc} = \eta_g + \eta_s - \eta_g \eta_s = 0.4 + 0.30 - 0.40 \times 0.30 = \mathbf{0.58}$$

10-113 The thermal efficiency of a combined gas-steam power plant η_{cc} can be expressed in terms of the thermal efficiencies of the gas and the steam turbine cycles as $\eta_{cc} = \eta_g + \eta_s - \eta_g \eta_s$. It is to be shown that the value of η_{cc} is greater than either of η_g or η_s .

Analysis By factoring out terms, the relation $\eta_{cc} = \eta_g + \eta_s - \eta_g \eta_s$ can be expressed as

$$\eta_{cc} = \eta_g + \eta_s - \eta_g \eta_s = \eta_g + \underbrace{\eta_s(1 - \eta_g)}_{\substack{\text{Positive since} \\ \eta_g < 1}} > \eta_g$$

or

$$\eta_{cc} = \eta_g + \eta_s - \eta_g \eta_s = \eta_s + \underbrace{\eta_g(1 - \eta_s)}_{\substack{\text{Positive since} \\ \eta_s < 1}} > \eta_s$$

Thus we conclude that the combined cycle is more efficient than either of the gas turbine or steam turbine cycles alone.

10-114 It is to be shown that the exergy destruction associated with a simple ideal Rankine cycle can be expressed as $x_{\text{destroyed}} = q_{\text{in}}(\eta_{\text{th,Carnot}} - \eta_{\text{th}})$, where η_{th} is efficiency of the Rankine cycle and $\eta_{\text{th,Carnot}}$ is the efficiency of the Carnot cycle operating between the same temperature limits.

Analysis The exergy destruction associated with a cycle is given on a unit mass basis as

$$x_{\text{destroyed}} = T_0 \sum \frac{q_R}{T_R}$$

where the direction of q_{in} is determined with respect to the reservoir (positive if to the reservoir and negative if from the reservoir). For a cycle that involves heat transfer only with a source at T_H and a sink at T_0 , the irreversibility becomes

$$\begin{aligned} x_{\text{destroyed}} &= T_0 \left(\frac{q_{\text{out}}}{T_0} - \frac{q_{\text{in}}}{T_H} \right) = q_{\text{out}} - \frac{T_0}{T_H} q_{\text{in}} = q_{\text{in}} \left(\frac{q_{\text{out}}}{q_{\text{in}}} - \frac{T_0}{T_H} \right) \\ &= q_{\text{in}} \left[(1 - \eta_{\text{th}}) - (1 - \eta_{\text{th,C}}) \right] = q_{\text{in}} (\eta_{\text{th,C}} - \eta_{\text{th}}) \end{aligned}$$

10-115 Thermal collection efficiency of a solar collector system is given. The operating temperature of the solar collector for maximum system efficiency is to be determined and an expression for maximum system efficiency is to be developed.

Analysis (a) The overall system efficiency is a product of the solar collector and power plant efficiencies, or

$$\eta = \eta_{\text{sc}} \eta_{\text{th}} = (A - BT_H) \left[F \left(1 - \frac{T_L}{T_H} \right) \right] = F \left(A - BT_H - A \frac{T_L}{T_H} + BT_L \right) \quad (1)$$

The maximum temperature is found when $\frac{d\eta}{dT_H} = 0$, for which the optimal T_H is

$$\frac{d\eta}{dT_H} = -B + A \frac{T_L}{T_H^2} = 0 \longrightarrow T_{H,\text{optimal}} = \sqrt{A \frac{T_L}{B}} \quad (2)$$

(b) Substituting Eq. (2) into Eq. (1) gives the maximum overall system efficiency:

$$\eta_{\text{max}} = F \left(A - B \sqrt{A \frac{T_L}{B}} - A \frac{T_L}{\sqrt{A \frac{T_L}{B}}} + BT_L \right) = F \left(\sqrt{A} - \sqrt{BT_L} \right)^2$$

Discussion A higher value of T_H increases the power plant efficiency but decreases the heat gained from the solar collector, and the converse. This problem illustrates how components integrated to form a system must be mutually adjusted to optimize system performance.

Fundamentals of Engineering (FE) Exam Problems

10-116 Consider a simple ideal Rankine cycle. If the condenser pressure is lowered while keeping turbine inlet state the same, (select the correct statement)

- (a) the turbine work output will decrease.
- (b) the amount of heat rejected will decrease.
- (c) the cycle efficiency will decrease.
- (d) the moisture content at turbine exit will decrease.
- (e) the pump work input will decrease.

Answer (b) the amount of heat rejected will decrease.

10-117 Consider a simple ideal Rankine cycle with fixed boiler and condenser pressures. If the steam is superheated to a higher temperature, (select the correct statement)

- (a) the turbine work output will decrease.
- (b) the amount of heat rejected will decrease.
- (c) the cycle efficiency will decrease.
- (d) the moisture content at turbine exit will decrease.
- (e) the amount of heat input will decrease.

Answer (d) the moisture content at turbine exit will decrease.

10-118 Consider a simple ideal Rankine cycle with fixed boiler and condenser pressures. If the cycle is modified with reheating, (select the correct statement)

- (a) the turbine work output will decrease.
- (b) the amount of heat rejected will decrease.
- (c) the pump work input will decrease.
- (d) the moisture content at turbine exit will decrease.
- (e) the amount of heat input will decrease.

Answer (d) the moisture content at turbine exit will decrease.

10-119 Consider a simple ideal Rankine cycle with fixed boiler and condenser pressures. If the cycle is modified with regeneration that involves one open feed water heater, (select the correct statement per unit mass of steam flowing through the boiler)

- (a) the turbine work output will decrease.
- (b) the amount of heat rejected will increase.
- (c) the cycle thermal efficiency will decrease.
- (d) the quality of steam at turbine exit will decrease.
- (e) the amount of heat input will increase.

Answer (a) the turbine work output will decrease.

10-120 Consider a steady-flow Carnot cycle with water as the working fluid executed under the saturation dome between the pressure limits of 3 MPa and 10 kPa. Water changes from saturated liquid to saturated vapor during the heat addition process. The net work output of this cycle is

- (a) 666 kJ/kg
- (b) 888 kJ/kg
- (c) 1040 kJ/kg
- (d) 1130 kJ/kg
- (e) 1440 kJ/kg

Answer (a) 666 kJ/kg

Solution Solved by EES Software. Solutions can be verified by copying-and-pasting the following lines on a blank EES screen. (Similar problems and their solutions can be obtained easily by modifying numerical values).

P1=33000 "kPa"

P2=10 "kPa"

h_fg=ENTHALPY(Steam_IAPWS,x=1,P=P1)-ENTHALPY(Steam_IAPWS,x=0,P=P1)

T1=TEMPERATURE(Steam_IAPWS,x=0,P=P1)+273

T2=TEMPERATURE(Steam_IAPWS,x=0,P=P2)+273

q_in=h_fg

Eta_Carnot=1-T2/T1

w_net=Eta_Carnot*q_in

"Some Wrong Solutions with Common Mistakes:"

W1_work = Eta1*q_in; Eta1=T2/T1 "Taking Carnot efficiency to be T2/T1"

W2_work = Eta2*q_in; Eta2=1-(T2-273)/(T1-273) "Using C instead of K"

W3_work = Eta_Carnot*ENTHALPY(Steam_IAPWS,x=1,P=P1) "Using h_g instead of h_fg"

W4_work = Eta_Carnot*q2; q2=ENTHALPY(Steam_IAPWS,x=1,P=P2)-ENTHALPY(Steam_IAPWS,x=0,P=P2)

"Using h_fg at P2"

10-121 A simple ideal Rankine cycle operates between the pressure limits of 10 kPa and 3 MPa, with a turbine inlet temperature of 600°C. Disregarding the pump work, the cycle efficiency is

- (a) 24% (b) 37% (c) 52% (d) 63% (e) 71%

Answer (b) 37%

Solution Solved by EES Software. Solutions can be verified by copying-and-pasting the following lines on a blank EES screen. (Similar problems and their solutions can be obtained easily by modifying numerical values).

```
P1=10 "kPa"
P2=3000 "kPa"
P3=P2
P4=P1
T3=600 "C"
s4=s3
h1=ENTHALPY(Steam_IAPWS,x=0,P=P1)
v1=VOLUME(Steam_IAPWS,x=0,P=P1)
w_pump=v1*(P2-P1) "kJ/kg"
h2=h1+w_pump
h3=ENTHALPY(Steam_IAPWS,T=T3,P=P3)
s3=ENTROPY(Steam_IAPWS,T=T3,P=P3)
h4=ENTHALPY(Steam_IAPWS,s=s4,P=P4)
q_in=h3-h2
q_out=h4-h1
Eta_th=1-q_out/q_in
```

"Some Wrong Solutions with Common Mistakes:"

W1_Eff = q_out/q_in "Using wrong relation"

W2_Eff = 1-(h44-h1)/(h3-h2); h44 = ENTHALPY(Steam_IAPWS,x=1,P=P4) "Using h_g for h4"

W3_Eff = 1-(T1+273)/(T3+273); T1=TEMPERATURE(Steam_IAPWS,x=0,P=P1) "Using Carnot efficiency"

W4_Eff = (h3-h4)/q_in "Disregarding pump work"

10-122 A simple ideal Rankine cycle operates between the pressure limits of 10 kPa and 5 MPa, with a turbine inlet temperature of 600°C. The mass fraction of steam that condenses at the turbine exit is

- (a) 6% (b) 9% (c) 12% (d) 15% (e) 18%

Answer (c) 12%

Solution Solved by EES Software. Solutions can be verified by copying-and-pasting the following lines on a blank EES screen. (Similar problems and their solutions can be obtained easily by modifying numerical values).

```
P1=10 "kPa"
P2=5000 "kPa"
P3=P2
P4=P1
T3=600 "C"
s4=s3
h3=ENTHALPY(Steam_IAPWS,T=T3,P=P3)
s3=ENTROPY(Steam_IAPWS,T=T3,P=P3)
h4=ENTHALPY(Steam_IAPWS,s=s4,P=P4)
x4=QUALITY(Steam_IAPWS,s=s4,P=P4)
moisture=1-x4
```

"Some Wrong Solutions with Common Mistakes:"

```
W1_moisture = x4 "Taking quality as moisture"
W2_moisture = 0 "Assuming superheated vapor"
```

10-123 A steam power plant operates on the simple ideal Rankine cycle between the pressure limits of 5 kPa and 10 MPa, with a turbine inlet temperature of 600°C. The rate of heat transfer in the boiler is 300 kJ/s. Disregarding the pump work, the power output of this plant is

- (a) 93 kW (b) 118 kW (c) 190 kW (d) 216 kW (e) 300 kW

Answer (b) 118 kW

Solution Solved by EES Software. Solutions can be verified by copying-and-pasting the following lines on a blank EES screen. (Similar problems and their solutions can be obtained easily by modifying numerical values).

```
P1=10 "kPa"
P2=5000 "kPa"
P3=P2
P4=P1
T3=600 "C"
s4=s3
Q_rate=300 "kJ/s"
m=Q_rate/q_in
h1=ENTHALPY(Steam_IAPWS,x=0,P=P1)
h2=h1 "pump work is neglected"
"v1=VOLUME(Steam_IAPWS,x=0,P=P1)
w_pump=v1*(P2-P1)
h2=h1+w_pump"
h3=ENTHALPY(Steam_IAPWS,T=T3,P=P3)
s3=ENTROPY(Steam_IAPWS,T=T3,P=P3)
h4=ENTHALPY(Steam_IAPWS,s=s4,P=P4)
q_in=h3-h2
W_turb=m*(h3-h4)
```

"Some Wrong Solutions with Common Mistakes:"

W1_power = Q_rate "Assuming all heat is converted to power"

W3_power = Q_rate*Carnot; Carnot = 1-(T1+273)/(T3+273); T1=TEMPERATURE(Steam_IAPWS,x=0,P=P1)

"Using Carnot efficiency"

W4_power = m*(h3-h44); h44 = ENTHALPY(Steam_IAPWS,x=1,P=P4) "Taking h4=h_g"

10-124 Consider a combined gas-steam power plant. Water for the steam cycle is heated in a well-insulated heat exchanger by the exhaust gases that enter at 800 K at a rate of 60 kg/s and leave at 400 K. Water enters the heat exchanger at 200°C and 8 MPa and leaves at 350°C and 8 MPa. If the exhaust gases are treated as air with constant specific heats at room temperature, the mass flow rate of water through the heat exchanger becomes

- (a) 11 kg/s (b) 24 kg/s (c) 46 kg/s (d) 53 kg/s (e) 60 kg/s

Answer (a) 11 kg/s

Solution Solved by EES Software. Solutions can be verified by copying-and-pasting the following lines on a blank EES screen. (Similar problems and their solutions can be obtained easily by modifying numerical values).

```
m_gas=60 "kg/s"
Cp=1.005 "kJ/kg.K"
T3=800 "K"
T4=400 "K"
Q_gas=m_gas*Cp*(T3-T4)
P1=8000 "kPa"
T1=200 "C"
P2=8000 "kPa"
T2=350 "C"
h1=ENTHALPY(Steam_IAPWS,T=T1,P=P1)
h2=ENTHALPY(Steam_IAPWS,T=T2,P=P2)
Q_steam=m_steam*(h2-h1)
Q_gas=Q_steam
```

"Some Wrong Solutions with Common Mistakes:"

```
m_gas*Cp*(T3 -T4)=W1_msteam*4.18*(T2-T1) "Assuming no evaporation of liquid water"
m_gas*Cv*(T3 -T4)=W2_msteam*(h2-h1); Cv=0.718 "Using Cv for air instead of Cp"
W3_msteam = m_gas "Taking the mass flow rates of two fluids to be equal"
m_gas*Cp*(T3 -T4)=W4_msteam*(h2-h1); h11=ENTHALPY(Steam_IAPWS,x=0,P=P1) "Taking h1=hf@P1"
```

10-125 An ideal reheat Rankine cycle operates between the pressure limits of 10 kPa and 8 MPa, with reheat occurring at 4 MPa. The temperature of steam at the inlets of both turbines is 500°C, and the enthalpy of steam is 3185 kJ/kg at the exit of the high-pressure turbine, and 2247 kJ/kg at the exit of the low-pressure turbine. Disregarding the pump work, the cycle efficiency is

- (a) 29% (b) 32% (c) 36% (d) 41% (e) 49%

Answer (d) 41%

Solution Solved by EES Software. Solutions can be verified by copying-and-pasting the following lines on a blank EES screen. (Similar problems and their solutions can be obtained easily by modifying numerical values).

```
P1=10 "kPa"
P2=8000 "kPa"
P3=P2
P4=4000 "kPa"
P5=P4
P6=P1
T3=500 "C"
T5=500 "C"
s4=s3
s6=s5
h1=ENTHALPY(Steam_IAPWS,x=0,P=P1)
h2=h1
h44=3185 "kJ/kg - for checking given data"
h66=2247 "kJ/kg - for checking given data"
h3=ENTHALPY(Steam_IAPWS,T=T3,P=P3)
s3=ENTROPY(Steam_IAPWS,T=T3,P=P3)
h4=ENTHALPY(Steam_IAPWS,s=s4,P=P4)
h5=ENTHALPY(Steam_IAPWS,T=T5,P=P5)
s5=ENTROPY(Steam_IAPWS,T=T5,P=P5)
h6=ENTHALPY(Steam_IAPWS,s=s6,P=P6)
q_in=(h3-h2)+(h5-h4)
q_out=h6-h1
Eta_th=1-q_out/q_in
```

"Some Wrong Solutions with Common Mistakes:"

W1_Eff = q_out/q_in "Using wrong relation"

W2_Eff = 1-q_out/(h3-h2) "Disregarding heat input during reheat"

W3_Eff = 1-(T1+273)/(T3+273); T1=TEMPERATURE(Steam_IAPWS,x=0,P=P1) "Using Carnot efficiency"

W4_Eff = 1-q_out/(h5-h2) "Using wrong relation for q_in"

10-126 Pressurized feedwater in a steam power plant is to be heated in an ideal open feedwater heater that operates at a pressure of 2 MPa with steam extracted from the turbine. If the enthalpy of feedwater is 252 kJ/kg and the enthalpy of extracted steam is 2810 kJ/kg, the mass fraction of steam extracted from the turbine is

- (a) 10% (b) 14% (c) 26% (d) 36% (e) 50%

Answer (c) 26%

Solution Solved by EES Software. Solutions can be verified by copying-and-pasting the following lines on a blank EES screen. (Similar problems and their solutions can be obtained easily by modifying numerical values).

```
h_feed=252 "kJ/kg"
h_extracted=2810 "kJ/kg"
P3=2000 "kPa"
h3=ENTHALPY(Steam_IAPWS,x=0,P=P3)
"Energy balance on the FWH"
h3=x_ext*h_extracted+(1-x_ext)*h_feed
```

"Some Wrong Solutions with Common Mistakes:"

```
W1_ext = h_feed/h_extracted "Using wrong relation"
W2_ext = h3/(h_extracted-h_feed) "Using wrong relation"
W3_ext = h_feed/(h_extracted-h_feed) "Using wrong relation"
```

10-127 Consider a steam power plant that operates on the regenerative Rankine cycle with one open feedwater heater. The enthalpy of the steam is 3374 kJ/kg at the turbine inlet, 2797 kJ/kg at the location of bleeding, and 2346 kJ/kg at the turbine exit. The net power output of the plant is 120 MW, and the fraction of steam bled off the turbine for regeneration is 0.172. If the pump work is negligible, the mass flow rate of steam at the turbine inlet is

- (a) 117 kg/s (b) 126 kg/s (c) 219 kg/s (d) 288 kg/s (e) 679 kg/s

Answer (b) 126 kg/s

Solution Solved by EES Software. Solutions can be verified by copying-and-pasting the following lines on a blank EES screen. (Similar problems and their solutions can be obtained easily by modifying numerical values).

```
h_in=3374 "kJ/kg"
h_out=2346 "kJ/kg"
h_extracted=2797 "kJ/kg"
Wnet_out=120000 "kW"
x_bleed=0.172
w_turb=(h_in-h_extracted)+(1-x_bleed)*(h_extracted-h_out)
m=Wnet_out/w_turb
```

"Some Wrong Solutions with Common Mistakes:"

```
W1_mass = Wnet_out/(h_in-h_out) "Disregarding extraction of steam"
W2_mass = Wnet_out/(x_bleed*(h_in-h_out)) "Assuming steam is extracted at turbine inlet"
W3_mass = Wnet_out/(h_in-h_out-x_bleed*h_extracted) "Using wrong relation"
```

10-128 Consider a cogeneration power plant modified with regeneration. Steam enters the turbine at 6 MPa and 450°C at a rate of 20 kg/s and expands to a pressure of 0.4 MPa. At this pressure, 60% of the steam is extracted from the turbine, and the remainder expands to a pressure of 10 kPa. Part of the extracted steam is used to heat feedwater in an open feedwater heater. The rest of the extracted steam is used for process heating and leaves the process heater as a saturated liquid at 0.4 MPa. It is subsequently mixed with the feedwater leaving the feedwater heater, and the mixture is pumped to the boiler pressure. The steam in the condenser is cooled and condensed by the cooling water from a nearby river, which enters the the adiabatic condenser at a rate of 463 kg/s.

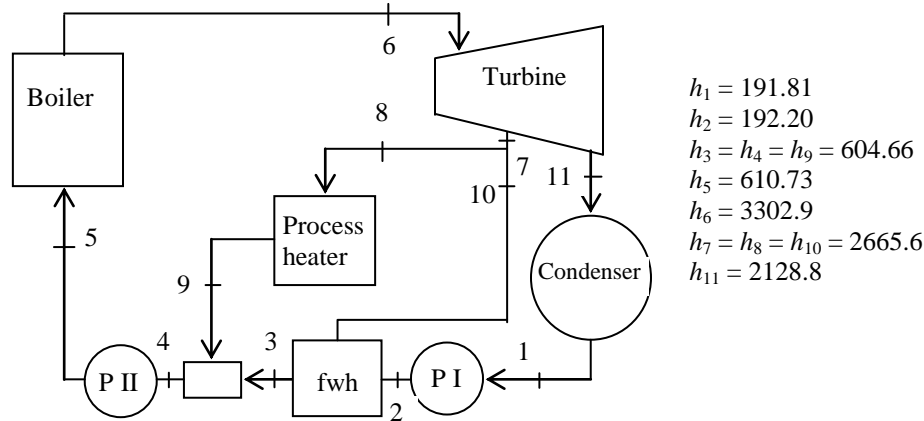

1. The total power output of the turbine is

- (a) 17.0 MW (b) 8.4 MW (c) 12.2 MW (d) 20.0 MW (e) 3.4 MW

Answer (a) 17.0 MW

2. The temperature rise of the cooling water from the river in the condenser is

- (a) 8.0°C (b) 5.2°C (c) 9.6°C (d) 12.9°C (e) 16.2°C

Answer (a) 8.0°C

3. The mass flow rate of steam through the process heater is

- (a) 1.6 kg/s (b) 3.8 kg/s (c) 5.2 kg/s (d) 7.6 kg/s (e) 10.4 kg/s

Answer (e) 10.4 kg/s

4. The rate of heat supply from the process heater per unit mass of steam passing through it is

- (a) 246 kJ/kg (b) 893 kJ/kg (c) 1344 kJ/kg (d) 1891 kJ/kg (e) 2060 kJ/kg

Answer (e) 2060 kJ/kg

5. The rate of heat transfer to the steam in the boiler is

- (a) 26.0 MJ/s (b) 53.8 MJ/s (c) 39.5 MJ/s (d) 62.8 MJ/s (e) 125.4 MJ/s

Answer (b) 53.8 MJ/s

Solution Solved by EES Software. Solutions can be verified by copying-and-pasting the following lines on a blank EES screen. (Similar problems and their solutions can be obtained easily by modifying numerical values).

Note: The solution given below also evaluates all enthalpies given on the figure.

```
P1=10 "kPa"
P11=P1
P2=400 "kPa"
P3=P2; P4=P2; P7=P2; P8=P2; P9=P2; P10=P2
P5=6000 "kPa"
P6=P5
T6=450 "C"
m_total=20 "kg/s"
m7=0.6*m_total
m_cond=0.4*m_total
C=4.18 "kJ/kg.K"
m_cooling=463 "kg/s"
s7=s6
s11=s6
h1=ENTHALPY(Steam_IAPWS,x=0,P=P1)
v1=VOLUME(Steam_IAPWS,x=0,P=P1)
w_pump=v1*(P2-P1)
h2=h1+w_pump
h3=ENTHALPY(Steam_IAPWS,x=0,P=P3)
h4=h3; h9=h3
v4=VOLUME(Steam_IAPWS,x=0,P=P4)
w_pump2=v4*(P5-P4)
h5=h4+w_pump2
h6=ENTHALPY(Steam_IAPWS,T=T6,P=P6)
s6=ENTROPY(Steam_IAPWS,T=T6,P=P6)
h7=ENTHALPY(Steam_IAPWS,s=s7,P=P7)
h8=h7; h10=h7
h11=ENTHALPY(Steam_IAPWS,s=s11,P=P11)
W_turb=m_total*(h6-h7)+m_cond*(h7-h11)
m_cooling*C*T_rise=m_cond*(h11-h1)
m_cond*h2+m_feed*h10=(m_cond+m_feed)*h3
m_process=m7-m_feed
q_process=h8-h9
Q_in=m_total*(h6-h5)
```

10-129 ... 10-136 Design and Essay Problems



Solutions Manual for
Thermodynamics: An Engineering Approach
8th Edition
Yunus A. Çengel, Michael A. Boles
McGraw-Hill, 2015

Chapter 11

REFRIGERATION CYCLES

PROPRIETARY AND CONFIDENTIAL

This Manual is the proprietary property of McGraw-Hill Education and protected by copyright and other state and federal laws. By opening and using this Manual the user agrees to the following restrictions, and if the recipient does not agree to these restrictions, the Manual should be promptly returned unopened to McGraw-Hill Education: **This Manual is being provided only to authorized professors and instructors for use in preparing for the classes using the affiliated textbook. No other use or distribution of this Manual is permitted. This Manual may not be sold and may not be distributed to or used by any student or other third party. No part of this Manual may be reproduced, displayed or distributed in any form or by any means, electronic or otherwise, without the prior written permission of McGraw-Hill Education.**

The Reversed Carnot Cycle

11-1C Because the compression process involves the compression of a liquid-vapor mixture which requires a compressor that will handle two phases, and the expansion process involves the expansion of high-moisture content refrigerant.

11-2C The reversed Carnot cycle serves as a standard against which actual refrigeration cycles can be compared. Also, the COP of the reversed Carnot cycle provides the upper limit for the COP of a refrigeration cycle operating between the specified temperature limits.

11-3 A steady-flow Carnot refrigeration cycle with refrigerant-134a as the working fluid is considered. The coefficient of performance, the amount of heat absorbed from the refrigerated space, and the net work input are to be determined.

Assumptions 1 Steady operating conditions exist. **2** Kinetic and potential energy changes are negligible.

Analysis (a) Noting that $T_H = 60^\circ\text{C} = 333\text{ K}$ and $T_L = T_{\text{sat}} @ 140\text{ kPa} = -18.77^\circ\text{C} = 254.2\text{ K}$, the COP of this Carnot refrigerator is determined from

$$\text{COP}_{\text{R,C}} = \frac{1}{T_H/T_L - 1} = \frac{1}{(333\text{ K})/(254.2\text{ K}) - 1} = \mathbf{3.227}$$

(b) From the refrigerant tables (Table A-11),

$$h_3 = h_{g@60^\circ\text{C}} = 278.47\text{ kJ/kg}$$

$$h_4 = h_{f@60^\circ\text{C}} = 139.38\text{ kJ/kg}$$

Thus,

$$q_H = h_3 - h_4 = 278.47 - 139.38 = 139.1\text{ kJ/kg}$$

and

$$\frac{q_H}{q_L} = \frac{T_H}{T_L} \longrightarrow q_L = \frac{T_L}{T_H} q_H = \left(\frac{254.2\text{ K}}{333\text{ K}} \right) (139.1\text{ kJ/kg}) = \mathbf{106.2\text{ kJ/kg}}$$

(c) The net work input is determined from

$$w_{\text{net}} = q_H - q_L = 139.1 - 106.2 = \mathbf{32.9\text{ kJ/kg}}$$

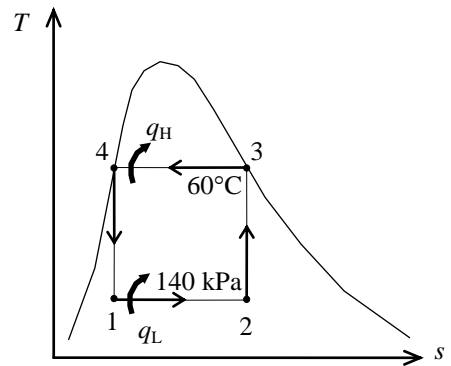

11-4E A steady-flow Carnot refrigeration cycle with refrigerant-134a as the working fluid is considered. The coefficient of performance, the quality at the beginning of the heat-absorption process, and the net work input are to be determined.

Assumptions 1 Steady operating conditions exist. 2 Kinetic and potential energy changes are negligible.

Analysis (a) Noting that $T_H = T_{\text{sat @ 90 psia}} = 72.78^\circ\text{F} = 532.8\text{ R}$ and $T_L = T_{\text{sat @ 30 psia}} = 15.37^\circ\text{F} = 475.4\text{ R}$.

$$\text{COP}_{\text{R,C}} = \frac{1}{T_H / T_L - 1} = \frac{1}{(532.8\text{ R}) / (475.4\text{ R}) - 1} = \mathbf{8.28}$$

(b) Process 4-1 is isentropic, and thus

$$s_1 = s_4 = (s_f + x_4 s_{fg})_{\text{@ 90 psia}} = 0.07481 + (0.05)(0.14529) \\ = 0.08208\text{ Btu/lbm}\cdot\text{R}$$

$$x_1 = \left(\frac{s_1 - s_f}{s_{fg}} \right)_{\text{@ 30 psia}} = \frac{0.08208 - 0.03792}{0.18595} = \mathbf{0.237}$$

(c) Remembering that on a T - s diagram the area enclosed represents the net work, and $s_3 = s_g \text{ @ 90 psia} = 0.22011\text{ Btu/lbm}\cdot\text{R}$,

$$w_{\text{net,in}} = (T_H - T_L)(s_3 - s_4) = (72.78 - 15.37)(0.22011 - 0.08208)\text{ Btu/lbm}\cdot\text{R} = \mathbf{7.92\text{ Btu/lbm}}$$

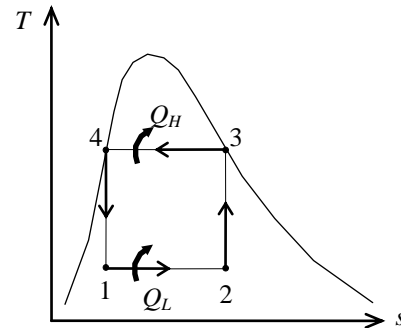

Ideal and Actual Vapor-Compression Refrigeration Cycles

11-5C To make the ideal vapor-compression refrigeration cycle more closely approximate the actual cycle.

11-6C No. Assuming the water is maintained at 10°C in the evaporator, the evaporator pressure will be the saturation pressure corresponding to this pressure, which is 1.2 kPa. It is not practical to design refrigeration or air-conditioning devices that involve such extremely low pressures.

11-7C Allowing a temperature difference of 10°C for effective heat transfer, the condensation temperature of the refrigerant should be 25°C . The saturation pressure corresponding to 25°C is 0.67 MPa. Therefore, the recommended pressure would be 0.7 MPa.

11-8C The area enclosed by the cyclic curve on a T - s diagram represents the net work input for the reversed Carnot cycle, but not so for the ideal vapor-compression refrigeration cycle. This is because the latter cycle involves an irreversible process for which the process path is not known.

11-9C The cycle that involves saturated liquid at 30°C will have a higher COP because, judging from the T - s diagram, it will require a smaller work input for the same refrigeration capacity.

11-10C The minimum temperature that the refrigerant can be cooled to before throttling is the temperature of the sink (the cooling medium) since heat is transferred from the refrigerant to the cooling medium.

11-11E An ice-making machine operates on the ideal vapor-compression refrigeration cycle, using refrigerant-134a as the working fluid. The power input to the ice machine is to be determined.

Assumptions 1 Steady operating conditions exist. 2 Kinetic and potential energy changes are negligible.

Analysis In an ideal vapor-compression refrigeration cycle, the compression process is isentropic, the refrigerant enters the compressor as a saturated vapor at the evaporator pressure, and leaves the condenser as saturated liquid at the condenser pressure. From the refrigerant tables (Tables A-12E and A-13E),

$$\left. \begin{array}{l} P_1 = 20 \text{ psia} \\ \text{sat. vapor} \end{array} \right\} \begin{array}{l} h_1 = h_g @ 20 \text{ psia} = 102.74 \text{ Btu/lbm} \\ s_1 = s_g @ 20 \text{ psia} = 0.22570 \text{ Btu/lbm} \cdot \text{R} \end{array}$$

$$\left. \begin{array}{l} P_2 = 80 \text{ psia} \\ s_2 = s_1 \end{array} \right\} h_2 = 115.01 \text{ Btu/lbm}$$

$$\left. \begin{array}{l} P_3 = 80 \text{ psia} \\ \text{sat. liquid} \end{array} \right\} h_3 = h_f @ 80 \text{ psia} = 33.39 \text{ Btu/lbm}$$

$$h_4 \cong h_3 = 33.39 \text{ Btu/lbm (throttling)}$$

The cooling load of this refrigerator is

$$\dot{Q}_L = \dot{m}_{\text{ice}} (\Delta h)_{\text{ice}} = (15/3600 \text{ lbm/s})(169 \text{ Btu/lbm}) = 0.7042 \text{ Btu/s}$$

Then the mass flow rate of the refrigerant and the power input become

$$\dot{m}_R = \frac{\dot{Q}_L}{h_1 - h_4} = \frac{0.7042 \text{ Btu/s}}{(102.74 - 33.39) \text{ Btu/lbm}} = 0.01015 \text{ lbm/s}$$

and

$$\dot{W}_{\text{in}} = \dot{m}_R (h_2 - h_1) = (0.01015 \text{ lbm/s})(115.01 - 102.74) \text{ Btu/lbm} \left(\frac{1 \text{ hp}}{0.7068 \text{ Btu/s}} \right) = \mathbf{0.176 \text{ hp}}$$

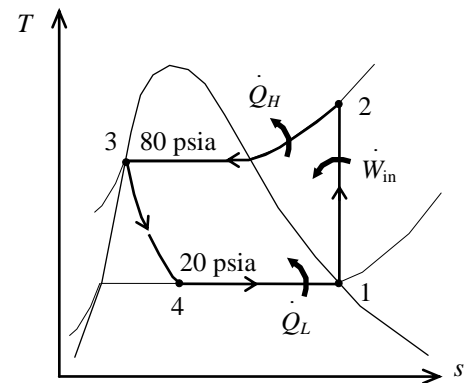

11-12E A refrigerator operating on the ideal vapor-compression refrigeration cycle with refrigerant-134a as the working fluid is considered. The increase in the COP if the throttling process were replaced by an isentropic expansion is to be determined.

Assumptions 1 Steady operating conditions exist. 2 Kinetic and potential energy changes are negligible.

Analysis In an ideal vapor-compression refrigeration cycle, the compression process is isentropic, the refrigerant enters the compressor as a saturated vapor at the evaporator pressure, and leaves the condenser as saturated liquid at the condenser pressure. From the refrigerant tables (Tables A-11E, A-12E, and A-13E),

$$\left. \begin{array}{l} T_1 = 20^\circ\text{F} \\ \text{sat. vapor} \end{array} \right\} \begin{array}{l} h_1 = h_g @ 20^\circ\text{F} = 106.00 \text{ Btu/lbm} \\ s_1 = s_g @ 20^\circ\text{F} = 0.22345 \text{ Btu/lbm} \cdot \text{R} \end{array}$$

$$\left. \begin{array}{l} P_2 = 300 \text{ psia} \\ s_2 = s_1 \end{array} \right\} h_2 = 125.70 \text{ Btu/lbm}$$

$$\left. \begin{array}{l} P_3 = 300 \text{ psia} \\ \text{sat. liquid} \end{array} \right\} \begin{array}{l} h_3 = h_f @ 300 \text{ psia} = 66.347 \text{ Btu/lbm} \\ s_3 = s_f @ 300 \text{ psia} = 0.12717 \text{ Btu/lbm} \cdot \text{R} \end{array}$$

$$h_4 \cong h_3 = 66.347 \text{ Btu/lbm} \quad (\text{throttling})$$

$$\left. \begin{array}{l} T_4 = 20^\circ\text{F} \\ s_4 = s_3 \end{array} \right\} \begin{array}{l} h_{4s} = 59.81 \text{ Btu/lbm} \\ x_{4s} = 0.4724 \end{array} \quad (\text{isentropic expansion})$$

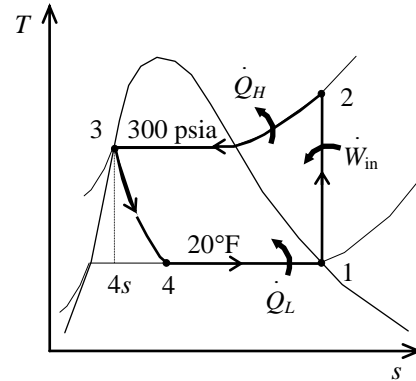

The COP of the refrigerator for the throttling case is

$$\text{COP}_R = \frac{q_L}{w_{\text{in}}} = \frac{h_1 - h_4}{h_2 - h_1} = \frac{106.00 - 66.347}{125.70 - 106.00} = \mathbf{2.013}$$

The COP of the refrigerator for the isentropic expansion case is

$$\text{COP}_R = \frac{q_L}{w_{\text{in}}} = \frac{h_1 - h_{4s}}{h_2 - h_1} = \frac{106.00 - 59.81}{125.70 - 106.00} = \mathbf{2.344}$$

The increase in the COP by isentropic expansion is

$$\text{Percent Increase in COP} = \frac{2.344 - 2.013}{2.013} = 0.165 = \mathbf{16.5\%}$$

11-13 An ideal vapor-compression refrigeration cycle with refrigerant-134a as the working fluid is considered. The COP and the power requirement are to be determined.

Assumptions 1 Steady operating conditions exist. 2 Kinetic and potential energy changes are negligible.

Analysis In an ideal vapor-compression refrigeration cycle, the compression process is isentropic, the refrigerant enters the compressor as a saturated vapor at the evaporator pressure, and leaves the condenser as saturated liquid at the condenser pressure. From the refrigerant tables (Tables A-11, A-12, and A-13),

$$\left. \begin{array}{l} T_1 = -12^\circ\text{C} \\ \text{sat. vapor} \end{array} \right\} \begin{array}{l} h_1 = h_g @ -12^\circ\text{C} = 243.34 \text{ kJ/kg} \\ s_1 = s_g @ -12^\circ\text{C} = 0.93925 \text{ kJ/kg}\cdot\text{K} \end{array}$$

$$\left. \begin{array}{l} P_2 = 0.8 \text{ MPa} \\ s_2 = s_1 \end{array} \right\} h_2 = 273.71 \text{ kJ/kg}$$

$$\left. \begin{array}{l} P_3 = 0.8 \text{ MPa} \\ \text{sat. liquid} \end{array} \right\} h_3 = h_f @ 1 \text{ MPa} = 95.48 \text{ kJ/kg}$$

$$h_4 \cong h_3 = 95.48 \text{ kJ/kg} \quad (\text{throttling})$$

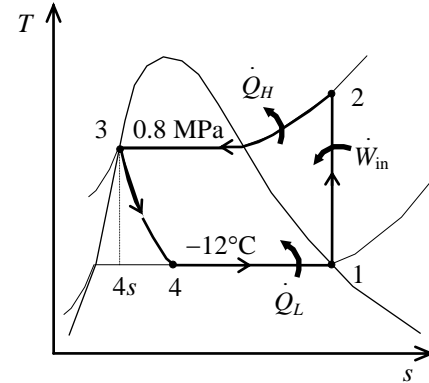

The mass flow rate of the refrigerant is

$$\dot{Q}_L = \dot{m}(h_1 - h_4) \longrightarrow \dot{m} = \frac{\dot{Q}_L}{h_1 - h_4} = \frac{150 \text{ kJ/s}}{(243.34 - 95.48) \text{ kJ/kg}} = 1.014 \text{ kg/s}$$

The power requirement is

$$\dot{W}_{\text{in}} = \dot{m}(h_2 - h_1) = (1.014 \text{ kg/s})(273.71 - 243.34) \text{ kJ/kg} = \mathbf{30.81 \text{ kW}}$$

The COP of the refrigerator is determined from its definition,

$$\text{COP}_R = \frac{\dot{Q}_L}{\dot{W}_{\text{in}}} = \frac{150 \text{ kW}}{30.81 \text{ kW}} = \mathbf{4.87}$$

11-14  An ideal vapor-compression refrigeration cycle with refrigerant-134a as the working fluid is considered. The quality of the refrigerant at the end of the throttling process, the COP, and the power input to the compressor are to be determined.

Assumptions 1 Steady operating conditions exist. 2 Kinetic and potential energy changes are negligible.

Analysis (a) In an ideal vapor-compression refrigeration cycle, the compression process is isentropic, the refrigerant enters the compressor as a saturated vapor at the evaporator pressure, and leaves the condenser as saturated liquid at the condenser pressure. From the refrigerant tables (Tables A-12 and A-13),

$$\left. \begin{array}{l} P_1 = 140 \text{ kPa} \\ \text{sat. vapor} \end{array} \right\} \begin{array}{l} h_1 = h_g @ 140 \text{ kPa} = 239.19 \text{ kJ/kg} \\ s_1 = s_g @ 140 \text{ kPa} = 0.94467 \text{ kJ/kg} \cdot \text{K} \end{array}$$

$$\left. \begin{array}{l} P_2 = 0.8 \text{ MPa} \\ s_2 = s_1 \end{array} \right\} h_2 = 275.40 \text{ kJ/kg}$$

$$\left. \begin{array}{l} P_3 = 0.8 \text{ MPa} \\ \text{sat. liquid} \end{array} \right\} h_3 = h_f @ 0.8 \text{ MPa} = 95.48 \text{ kJ/kg}$$

$$h_4 \cong h_3 = 95.48 \text{ kJ/kg (throttling)}$$

The quality of the refrigerant at the end of the throttling process is

$$x_4 = \left(\frac{h_4 - h_f}{h_{fg}} \right) @ 140 \text{ kPa} = \frac{95.48 - 27.06}{212.13} = \mathbf{0.3225}$$

(b) The COP of the refrigerator is determined from its definition,

$$\text{COP}_R = \frac{q_L}{w_{\text{in}}} = \frac{h_1 - h_4}{h_2 - h_1} = \frac{239.19 - 95.48}{275.40 - 239.19} = \mathbf{3.969}$$

(c) The power input to the compressor is determined from

$$\dot{W}_{\text{in}} = \frac{\dot{Q}_L}{\text{COP}_R} = \frac{(300/60) \text{ kW}}{3.969} = \mathbf{1.260 \text{ kW}}$$

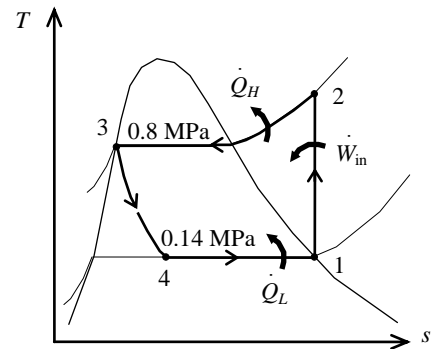



11-15 Problem 11-14 is reconsidered. The effect of evaporator pressure on the COP and the power input is to be investigated.

Analysis The problem is solved using EES, and the solution is given below.

"Input Data"

```
{P[1]=140 [kPa]}
{P[2] = 800 [kPa]}
Fluid$='R134a'
Eta_c=1.0 "Compressor isentropic efficiency"
Q_dot_in=300/60 "[kJ/s]"
```

"Compressor"

```
x[1]=1 "assume inlet to be saturated vapor"
h[1]=enthalpy(Fluid$,P=P[1],x=x[1])
T[1]=temperature(Fluid$,h=h[1],P=P[1]) "properties for state 1"
s[1]=entropy(Fluid$,T=T[1],x=x[1])
h2s=enthalpy(Fluid$,P=P[2],s=s[1]) "Identifies state 2s as isentropic"
h[1]+Wcs=h2s "energy balance on isentropic compressor"
Wc=Wcs/Eta_c "definition of compressor isentropic efficiency"
h[1]+Wc=h[2] "energy balance on real compressor-assumed adiabatic"
s[2]=entropy(Fluid$,h=h[2],P=P[2]) "properties for state 2"
T[2]=temperature(Fluid$,h=h[2],P=P[2])
W_dot_c=m_dot*Wc
```

"Condenser"

```
P[3]=P[2] "neglect pressure drops across condenser"
T[3]=temperature(Fluid$,h=h[3],P=P[3]) "properties for state 3"
h[3]=enthalpy(Fluid$,P=P[3],x=0) "properties for state 3"
s[3]=entropy(Fluid$,T=T[3],x=0)
h[2]=q_out+h[3] "energy balance on condenser"
Q_dot_out=m_dot*q_out
```

"Valve"

```
h[4]=h[3] "energy balance on throttle - isenthalpic"
x[4]=quality(Fluid$,h=h[4],P=P[4]) "properties for state 4"
s[4]=entropy(Fluid$,h=h[4],P=P[4])
T[4]=temperature(Fluid$,h=h[4],P=P[4])
```

"Evaporator"

```
P[4]=P[1] "neglect pressure drop across evaporator"
q_in + h[4]=h[1] "energy balance on evaporator"
Q_dot_in=m_dot*q_in
COP=Q_dot_in/W_dot_c "definition of COP"
COP_plot = COP
W_dot_in = W_dot_c
```

P_1 [kPa]	COP_{plot}	W_{in} [kW]
100	3.217	1.554
175	4.656	1.074
250	6.315	0.7917
325	8.388	0.5961
400	11.15	0.4483

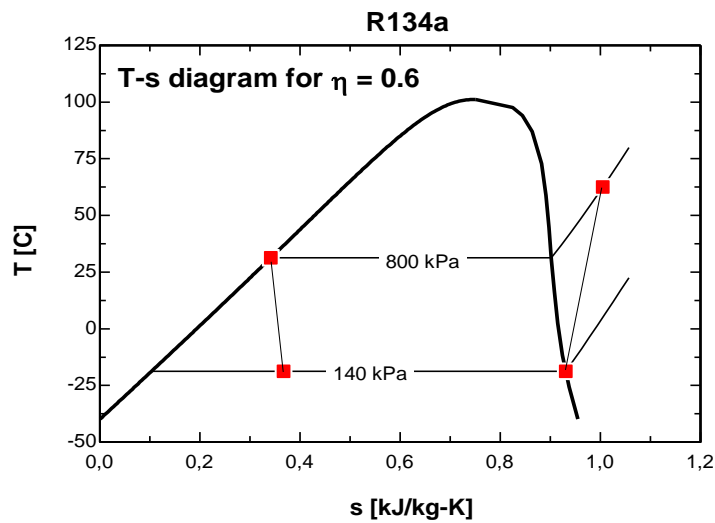
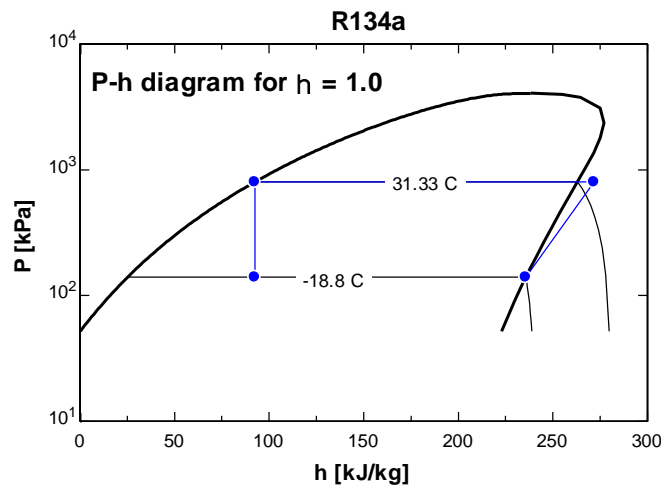
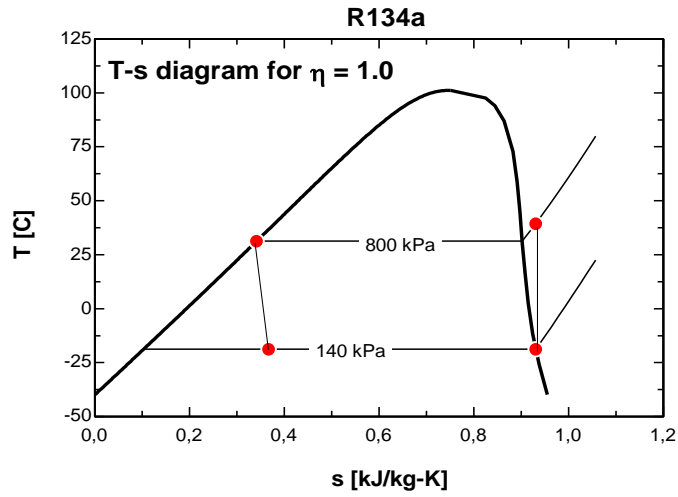

COP vs Compressor Efficiency for R134a

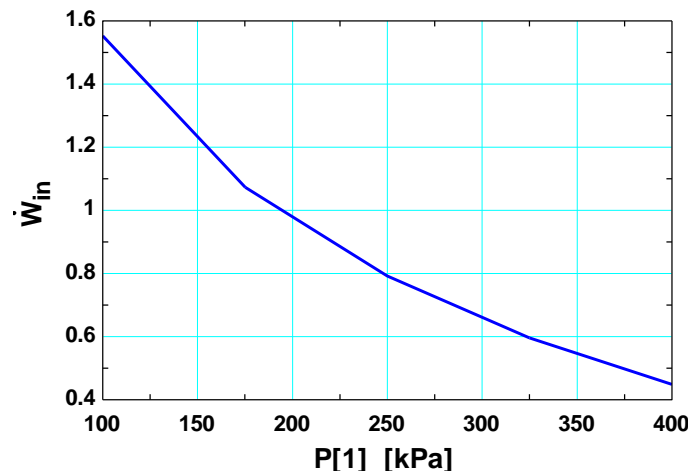
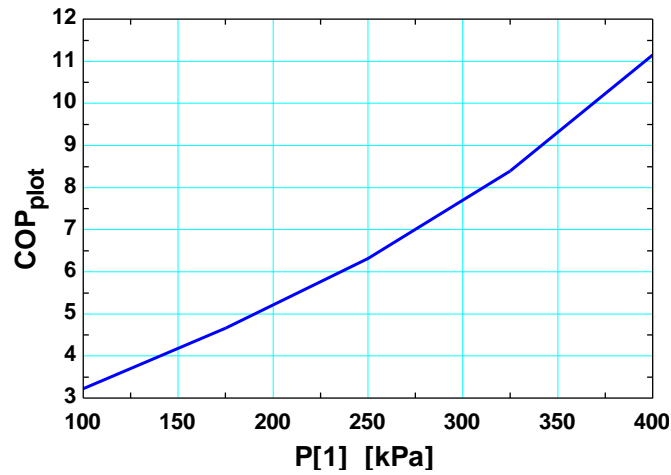
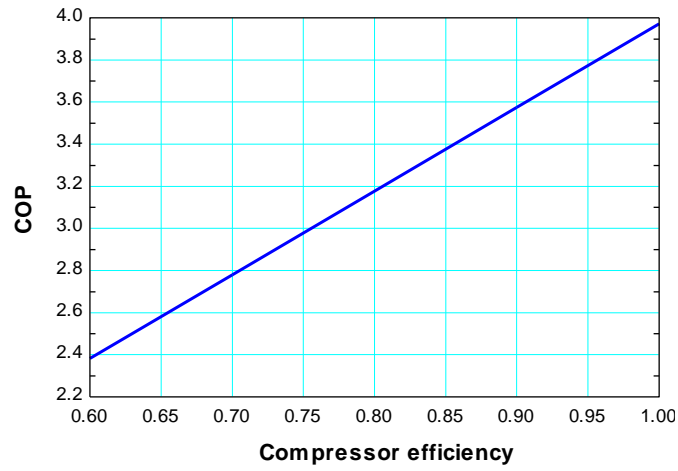

11-16 A nonideal vapor-compression refrigeration cycle with refrigerant-134a as the working fluid is considered. The quality of the refrigerant at the end of the throttling process, the COP, the power input to the compressor, and the irreversibility rate associated with the compression process are to be determined.

Assumptions 1 Steady operating conditions exist. 2 Kinetic and potential energy changes are negligible.

Analysis (a) The refrigerant enters the compressor as a saturated vapor at the evaporator pressure, and leaves the condenser as saturated liquid at the condenser pressure. From the refrigerant tables (Tables A-12 and A-13),

$$\begin{aligned} P_1 = 140 \text{ kPa} & \left. \begin{aligned} h_1 &= h_g @ 140 \text{ kPa} = 239.19 \text{ kJ/kg} \\ \text{sat. vapor} & \left. \begin{aligned} s_1 &= s_g @ 140 \text{ kPa} = 0.94467 \text{ kJ/kg} \cdot \text{K} \end{aligned} \right\} \end{aligned} \right\} \\ P_2 = 0.8 \text{ MPa} & \left. \begin{aligned} h_{2s} &= 275.40 \text{ kJ/kg} \\ s_{2s} &= s_1 \end{aligned} \right\} \\ \eta_C = \frac{h_{2s} - h_1}{h_2 - h_1} & \longrightarrow h_2 = h_1 + (h_{2s} - h_1)/\eta_C \\ & = 239.19 + (275.40 - 239.19)/(0.85) \\ & = 281.79 \text{ kJ/kg} \\ P_3 = 0.8 \text{ MPa} & \left. \begin{aligned} h_3 &= h_f @ 0.8 \text{ MPa} = 95.48 \text{ kJ/kg} \\ \text{sat. liquid} & \end{aligned} \right\} \\ h_4 \cong h_3 &= 95.48 \text{ kJ/kg (throttling)} \end{aligned}$$

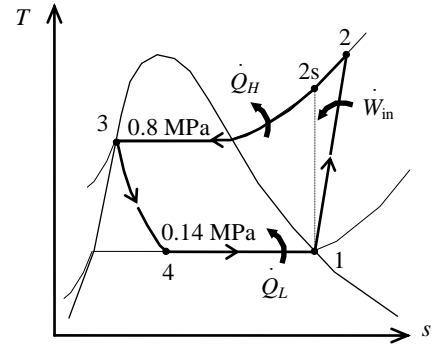

The quality of the refrigerant at the end of the throttling process is

$$x_4 = \left(\frac{h_4 - h_f}{h_{fg}} \right)_{@ 140 \text{ kPa}} = \frac{95.48 - 27.06}{212.13} = \mathbf{0.323}$$

(b) The COP of the refrigerator is determined from its definition,

$$\text{COP}_R = \frac{q_L}{w_{\text{in}}} = \frac{h_1 - h_4}{h_2 - h_1} = \frac{239.19 - 95.48}{281.79 - 239.19} = \mathbf{3.373}$$

(c) The power input to the compressor is determined from

$$\dot{W}_{\text{in}} = \frac{\dot{Q}_L}{\text{COP}_R} = \frac{5 \text{ kW}}{3.373} = \mathbf{1.48 \text{ kW}}$$

The exergy destruction associated with the compression process is determined from

$$\dot{X}_{\text{destroyed}} = T_0 \dot{S}_{\text{gen}} = T_0 \dot{m} \left(s_2 - s_1 + \frac{q_{\text{surr}}}{T_0} \right) = T_0 \dot{m} (s_2 - s_1)$$

where

$$\dot{m} = \frac{\dot{Q}_L}{q_L} = \frac{\dot{Q}_L}{h_1 - h_4} = \frac{5 \text{ kJ/s}}{(239.19 - 95.48) \text{ kJ/kg}} = 0.03479 \text{ kg/s}$$

$$\left. \begin{aligned} P_2 &= 0.8 \text{ MPa} \\ h_2 &= 281.79 \text{ kJ/kg} \end{aligned} \right\} s_2 = 0.96494 \text{ kJ/kg} \cdot \text{K}$$

Thus,

$$\dot{X}_{\text{destroyed}} = (298 \text{ K})(0.03479 \text{ kg/s})(0.96494 - 0.94467) \text{ kJ/kg} \cdot \text{K} = \mathbf{0.210 \text{ kW}}$$

11-17 A refrigerator with refrigerant-134a as the working fluid is considered. The rate of heat removal from the refrigerated space, the power input to the compressor, the isentropic efficiency of the compressor, and the COP of the refrigerator are to be determined.

Assumptions 1 Steady operating conditions exist. 2 Kinetic and potential energy changes are negligible.

Analysis (a) From the refrigerant tables (Tables A-12 and A-13),

$$\left. \begin{array}{l} P_1 = 0.20 \text{ MPa} \\ T_1 = -5^\circ\text{C} \end{array} \right\} \begin{array}{l} h_1 = 248.82 \text{ kJ/kg} \\ s_1 = 0.95414 \text{ kJ/kg} \cdot \text{K} \end{array}$$

$$\left. \begin{array}{l} P_2 = 1.2 \text{ MPa} \\ T_2 = 70^\circ\text{C} \end{array} \right\} h_2 = 300.63 \text{ kJ/kg}$$

$$\left. \begin{array}{l} P_{2s} = 1.2 \text{ MPa} \\ s_{2s} = s_1 \end{array} \right\} h_{2s} = 287.23 \text{ kJ/kg}$$

$$\left. \begin{array}{l} P_3 = 1.15 \text{ MPa} \\ T_3 = 44^\circ\text{C} \end{array} \right\} h_3 = h_f @ 44^\circ\text{C} = 114.30 \text{ kJ/kg}$$

$$h_4 \cong h_3 = 114.30 \text{ kJ/kg (throttling)}$$

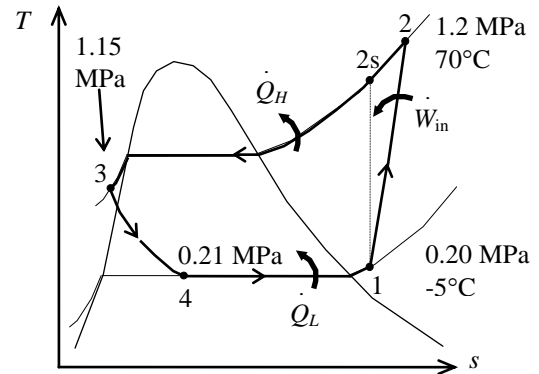

Then the rate of heat removal from the refrigerated space and the power input to the compressor are determined from

$$\dot{Q}_L = \dot{m}(h_1 - h_4) = (0.07 \text{ kg/s})(248.82 - 114.30) \text{ kJ/kg} = \mathbf{9.416 \text{ kW}}$$

and

$$\dot{W}_{\text{in}} = \dot{m}(h_2 - h_1) = (0.07 \text{ kg/s})(300.63 - 248.82) \text{ kJ/kg} = \mathbf{3.627 \text{ kW}}$$

(b) The isentropic efficiency of the compressor is determined from

$$\eta_C = \frac{h_{2s} - h_1}{h_2 - h_1} = \frac{287.23 - 248.82}{300.63 - 248.82} = 0.7414 = \mathbf{74.1\%}$$

(c) The COP of the refrigerator is determined from its definition,

$$\text{COP}_R = \frac{\dot{Q}_L}{\dot{W}_{\text{in}}} = \frac{9.416 \text{ kW}}{3.627 \text{ kW}} = \mathbf{2.60}$$

11-18 A commercial refrigerator with refrigerant-134a as the working fluid is considered. The quality of the refrigerant at the evaporator inlet, the refrigeration load, the COP of the refrigerator, and the theoretical maximum refrigeration load for the same power input to the compressor are to be determined.

Assumptions 1 Steady operating conditions exist. 2 Kinetic and potential energy changes are negligible.

Analysis (a) From refrigerant-134a tables (Tables A-11 through A-13)

$$\left. \begin{array}{l} P_1 = 60 \text{ kPa} \\ T_1 = -34^\circ\text{C} \end{array} \right\} h_1 = 230.04 \text{ kJ/kg}$$

$$\left. \begin{array}{l} P_2 = 1200 \text{ kPa} \\ T_2 = 65^\circ\text{C} \end{array} \right\} h_2 = 295.18 \text{ kJ/kg}$$

$$\left. \begin{array}{l} P_3 = 1200 \text{ kPa} \\ T_3 = 42^\circ\text{C} \end{array} \right\} h_3 = 111.25 \text{ kJ/kg}$$

$$h_4 = h_3 = 111.25 \text{ kJ/kg}$$

$$\left. \begin{array}{l} P_4 = 60 \text{ kPa} \\ h_4 = 111.25 \text{ kJ/kg} \end{array} \right\} x_4 = \mathbf{0.4796}$$

Using saturated liquid enthalpy at the given temperature, for water we have (Table A-4)

$$h_{w1} = h_f @ 18^\circ\text{C} = 75.47 \text{ kJ/kg}$$

$$h_{w2} = h_f @ 26^\circ\text{C} = 108.94 \text{ kJ/kg}$$

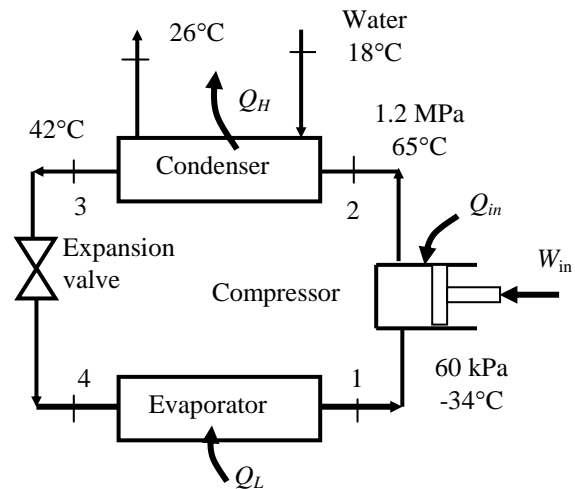

(b) The mass flow rate of the refrigerant may be determined from an energy balance on the compressor

$$\dot{m}_R (h_2 - h_3) = \dot{m}_w (h_{w2} - h_{w1})$$

$$\dot{m}_R (295.18 - 111.25) \text{ kJ/kg} = (0.25 \text{ kg/s})(108.94 - 75.47) \text{ kJ/kg}$$

$$\longrightarrow \dot{m}_R = 0.04549 \text{ kg/s}$$

The waste heat transferred from the refrigerant, the compressor power input, and the refrigeration load are

$$\dot{Q}_H = \dot{m}_R (h_2 - h_3) = (0.04549 \text{ kg/s})(295.18 - 111.25) \text{ kJ/kg} = 8.367 \text{ kW}$$

$$\dot{W}_{\text{in}} = \dot{m}_R (h_2 - h_1) - \dot{Q}_{\text{in}} = (0.04549 \text{ kg/s})(295.18 - 230.04) \text{ kJ/kg} - 0.450 \text{ kW} = 2.513 \text{ kW}$$

$$\dot{Q}_L = \dot{Q}_H - \dot{W}_{\text{in}} - \dot{Q}_{\text{in}} = 8.367 - 2.513 - 0.450 = \mathbf{5.404 \text{ kW}}$$

(c) The COP of the refrigerator is determined from its definition

$$\text{COP} = \frac{\dot{Q}_L}{\dot{W}_{\text{in}}} = \frac{5.404}{2.513} = \mathbf{2.15}$$

(d) The reversible COP of the refrigerator for the same temperature limits is

$$\text{COP}_{\text{max}} = \frac{1}{T_H / T_L - 1} = \frac{1}{(18 + 273) / (-30 + 273) - 1} = 5.063$$

Then, the maximum refrigeration load becomes

$$\dot{Q}_{L,\text{max}} = \text{COP}_{\text{max}} \dot{W}_{\text{in}} = (5.063)(2.513 \text{ kW}) = \mathbf{12.72 \text{ kW}}$$

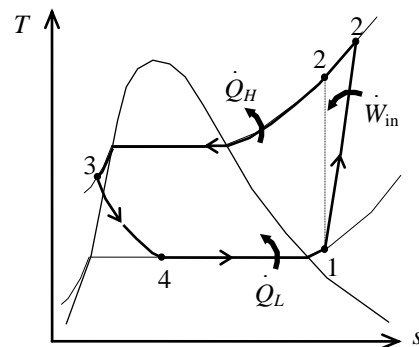

11-19 A refrigerator with refrigerant-134a as the working fluid is considered. The power input to the compressor, the rate of heat removal from the refrigerated space, and the pressure drop and the rate of heat gain in the line between the evaporator and the compressor are to be determined.

Assumptions 1 Steady operating conditions exist. 2 Kinetic and potential energy changes are negligible.

Analysis (a) From the refrigerant tables (Tables A-12 and A-13),

$$\left. \begin{array}{l} P_1 = 100 \text{ kPa} \\ T_1 = -20^\circ\text{C} \end{array} \right\} \begin{array}{l} h_1 = 239.52 \text{ kJ/kg} \\ s_1 = 0.97215 \text{ kJ/kg} \cdot \text{K} \\ \nu_1 = 0.19841 \text{ m}^3/\text{kg} \end{array}$$

$$\left. \begin{array}{l} P_2 = 0.8 \text{ MPa} \\ s_{2s} = s_1 \end{array} \right\} \begin{array}{l} h_{2s} = 284.09 \text{ kJ/kg} \end{array}$$

$$\left. \begin{array}{l} P_3 = 0.75 \text{ MPa} \\ T_3 = 26^\circ\text{C} \end{array} \right\} \begin{array}{l} h_3 \cong h_f @ 26^\circ\text{C} = 87.83 \text{ kJ/kg} \end{array}$$

$$h_4 \cong h_3 = 87.83 \text{ kJ/kg} \text{ (throttling)}$$

$$\left. \begin{array}{l} T_5 = -26^\circ\text{C} \\ \text{sat. vapor} \end{array} \right\} \begin{array}{l} P_5 = 0.10173 \text{ MPa} \\ h_5 = 234.70 \text{ kJ/kg} \end{array}$$

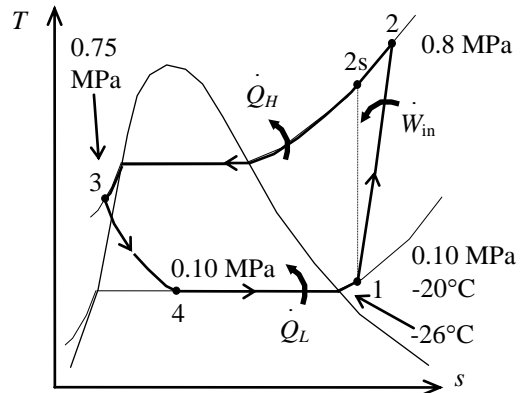

Then the mass flow rate of the refrigerant and the power input becomes

$$\dot{m} = \frac{\dot{V}_1}{\nu_1} = \frac{0.5/60 \text{ m}^3/\text{s}}{0.19841 \text{ m}^3/\text{kg}} = 0.04200 \text{ kg/s}$$

$$\dot{W}_{\text{in}} = \dot{m}(h_{2s} - h_1) / \eta_C = (0.04200 \text{ kg/s})[(284.09 - 239.52) \text{ kJ/kg}] / (0.78) = \mathbf{2.40 \text{ kW}}$$

(b) The rate of heat removal from the refrigerated space is

$$\dot{Q}_L = \dot{m}(h_5 - h_4) = (0.04200 \text{ kg/s})(234.70 - 87.83) \text{ kJ/kg} = \mathbf{6.17 \text{ kW}}$$

(c) The pressure drop and the heat gain in the line between the evaporator and the compressor are

$$\Delta P = P_5 - P_1 = 101.73 - 100 = \mathbf{1.73}$$

and

$$\dot{Q}_{\text{gain}} = \dot{m}(h_1 - h_5) = (0.04200 \text{ kg/s})(239.52 - 234.70) \text{ kJ/kg} = \mathbf{0.203 \text{ kW}}$$



11-20 Problem 11-19 is reconsidered. The effects of the compressor isentropic efficiency and the compressor inlet volume flow rate on the power input and the rate of refrigeration are to be investigated.

Analysis The problem is solved using EES, and the solution is given below.

"Given"

P[1]=100 [kPa]
 T[1]=-20 [C]
 V_dot=0.5 [m^3/min]
 P[2]=800 [kPa]
 "Eta_C=0.78"
 P[3]=750 [kPa]
 T[3]=26 [C]
 T[5]=-26 [C]
 x[5]=1

"Analysis"

Fluid\$='R134a'

"compressor"

h[1]=enthalpy(Fluid\$, P=P[1], T=T[1])
 s[1]=entropy(Fluid\$, P=P[1], T=T[1])
 v[1]=volume(Fluid\$, P=P[1], T=T[1])
 s_s[2]=s[1]
 h_s[2]=enthalpy(Fluid\$, P=P[2], s=s_s[2])

"expansion valve"

x[3]=0 "assumed saturated liquid"
 h[3]=enthalpy(Fluid\$, T=T[3], x=x[3])
 h[4]=h[3]

"evaporator exit"

h[5]=enthalpy(Fluid\$, T=T[5], x=x[5])
 P[5]=pressure(Fluid\$, T=T[5], x=x[5])

"cycle"

m_dot=V_dot/v[1]*Convert(kg/min, kg/s)
 W_dot_in=m_dot*(h_s[2]-h[1])/Eta_C
 Q_dot_L=m_dot*(h[5]-h[4])
 DELTAP=P[5]-P[1]
 Q_dot_gain=m_dot*(h[1]-h[5])

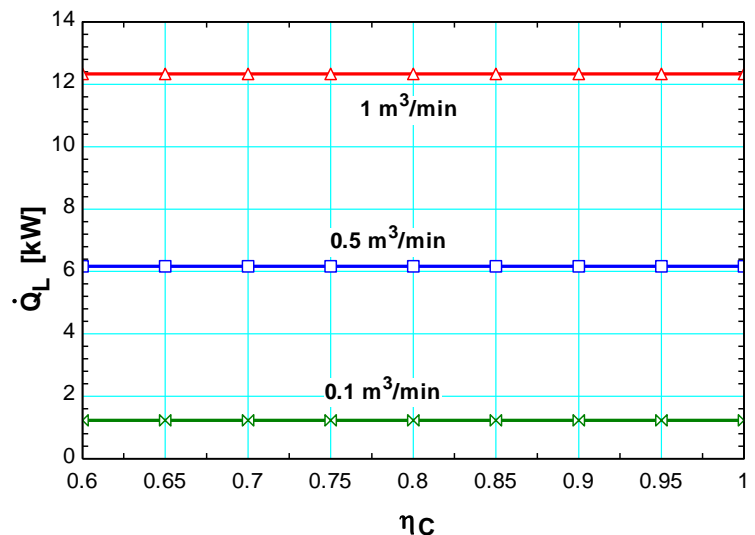
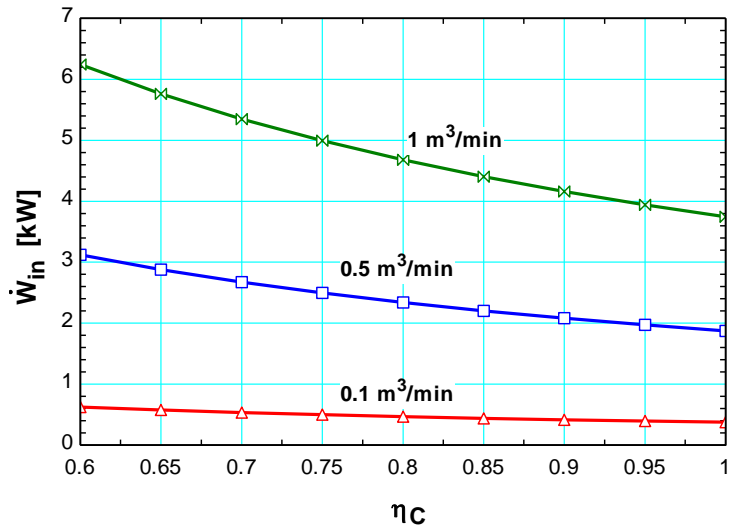

η _c	W _{in} [kW]	Q _L [kW]
0.6	3.12	6.169
0.65	2.88	6.169
0.7	2.674	6.169
0.75	2.496	6.169
0.8	2.34	6.169
0.85	2.202	6.169
0.9	2.08	6.169
0.95	1.971	6.169
1	1.872	6.169

11-21 A refrigerator uses refrigerant-134a as the working fluid and operates on the ideal vapor-compression refrigeration cycle except for the compression process. The mass flow rate of the refrigerant, the condenser pressure, and the COP of the refrigerator are to be determined.

Assumptions 1 Steady operating conditions exist. **2** Kinetic and potential energy changes are negligible.

Analysis (a) (b) From the refrigerant-134a tables (Tables A-11 through A-13)

$$\left. \begin{array}{l} P_4 = 120 \text{ kPa} \\ x_4 = 0.34 \end{array} \right\} h_4 = 95.41 \text{ kJ/kg}$$

$$h_3 = h_4$$

$$\left. \begin{array}{l} h_3 = 95.41 \text{ kJ/kg} \\ x_3 = 0 \text{ (sat. liq.)} \end{array} \right\} P_3 = 799 \text{ kPa} \cong \mathbf{800 \text{ kPa}}$$

$$P_2 = P_3$$

$$\left. \begin{array}{l} P_2 = 799 \text{ kPa} \\ T_2 = 70^\circ\text{C} \end{array} \right\} h_2 = 306.92 \text{ kJ/kg}$$

$$\left. \begin{array}{l} P_1 = P_4 = 120 \text{ kPa} \\ x_1 = 1 \text{ (sat. vap.)} \end{array} \right\} h_1 = 236.99 \text{ kJ/kg}$$

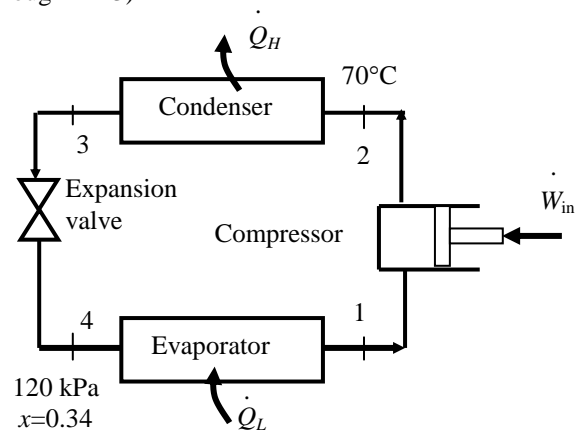

The mass flow rate of the refrigerant is determined from

$$\dot{m} = \frac{\dot{W}_{in}}{h_2 - h_1} = \frac{0.45 \text{ kW}}{(306.92 - 236.99) \text{ kJ/kg}} = \mathbf{0.006435 \text{ kg/s}}$$

(c) The refrigeration load and the COP are

$$\begin{aligned} \dot{Q}_L &= \dot{m}(h_1 - h_4) \\ &= (0.06435 \text{ kg/s})(236.99 - 95.41) \text{ kJ/kg} \\ &= 0.9111 \text{ kW} \end{aligned}$$

$$\text{COP} = \frac{\dot{Q}_L}{\dot{W}_{in}} = \frac{0.9111 \text{ kW}}{0.45 \text{ kW}} = \mathbf{2.03}$$

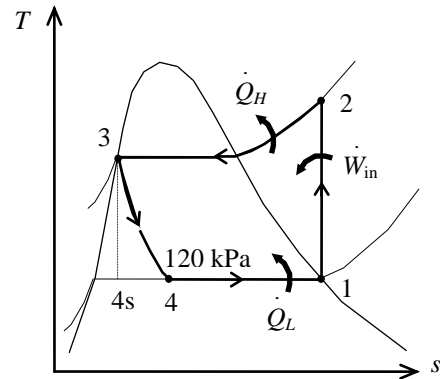

11-22 A vapor-compression refrigeration cycle with refrigerant-22 as the working fluid is considered. The hardware and the T - s diagram for this air conditioner are to be sketched. The heat absorbed by the refrigerant, the work input to the compressor and the heat rejected in the condenser are to be determined.

Assumptions 1 Steady operating conditions exist. 2 Kinetic and potential energy changes are negligible.

Analysis (a) In this normal vapor-compression refrigeration cycle, the refrigerant enters the compressor as a saturated vapor at the evaporator pressure, and leaves the condenser as saturated liquid at the condenser pressure.

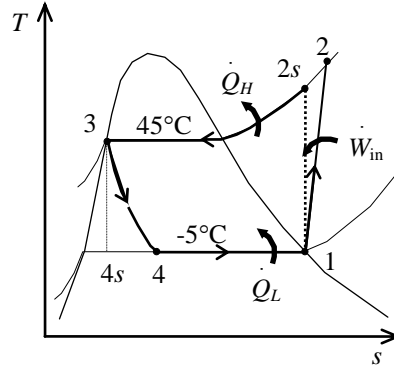
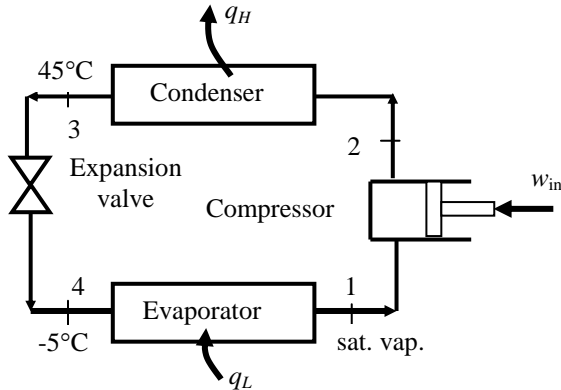

(b) The properties as given in the problem statement are

$$h_4 = h_3 = h_f @ 45^\circ\text{C} = 101 \text{ kJ/kg}$$

$$h_1 = h_g @ -5^\circ\text{C} = 248.1 \text{ kJ/kg.}$$

The heat absorbed by the refrigerant in the evaporator is

$$q_L = h_1 - h_4 = 248.1 - 101 = \mathbf{147.1 \text{ kJ/kg}}$$

(c) The COP of the air conditioner is

$$\text{COP}_R = \text{SEER} \left(\frac{1 \text{ W}}{3.412 \text{ Btu/h}} \right) = \left(16 \frac{\text{Btu/h}}{\text{W}} \right) \left(\frac{1 \text{ W}}{3.412 \text{ Btu/h}} \right) = 4.689$$

The work input to the compressor is

$$\text{COP}_R = \frac{q_L}{w_{\text{in}}} \longrightarrow w_{\text{in}} = \frac{q_L}{\text{COP}_R} = \frac{147.1 \text{ kJ/kg}}{4.689} = \mathbf{31.4 \text{ kJ/kg}}$$

The enthalpy at the compressor exit is

$$w_{\text{in}} = h_2 - h_1 \longrightarrow h_2 = h_1 + w_{\text{in}} = 248.1 \text{ kJ/kg} + 31.4 \text{ kJ/kg} = 279.5 \text{ kJ/kg}$$

The heat rejected from the refrigerant in the condenser is then

$$q_H = h_2 - h_3 = 279.5 - 101 = \mathbf{178.5 \text{ kJ/kg}}$$

11-23 A vapor-compression refrigeration cycle with refrigerant-134a as the working fluid is considered. The amount of cooling, the work input, and the COP are to be determined. Also, the same parameters are to be determined if the cycle operated on the ideal vapor-compression refrigeration cycle between the same temperature limits.

Assumptions 1 Steady operating conditions exist. 2 Kinetic and potential energy changes are negligible.

Analysis (a) The expansion process through the expansion valve is isenthalpic: $h_4 = h_3$. Then,

$$q_L = h_1 - h_4 = 402.49 - 243.19 = \mathbf{159.3 \text{ kJ/kg}}$$

$$q_H = h_2 - h_3 = 454.00 - 243.19 = 210.8 \text{ kJ/kg}$$

$$w_{\text{in}} = h_2 - h_1 = 454.00 - 402.49 = \mathbf{51.51 \text{ kJ/kg}}$$

$$\text{COP} = \frac{q_L}{w_{\text{in}}} = \frac{159.3 \text{ kJ/kg}}{51.51 \text{ kJ/kg}} = \mathbf{3.093}$$

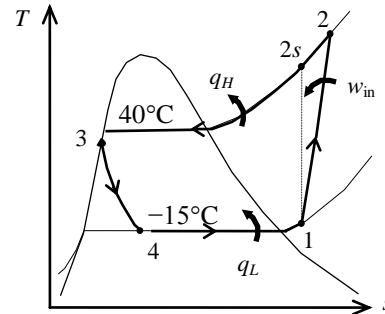

(c) Ideal vapor-compression refrigeration cycle solution:

$$q_L = h_1 - h_4 = 399.04 - 249.80 = \mathbf{149.2 \text{ kJ/kg}}$$

$$q_H = h_2 - h_3 = 440.71 - 249.80 = 190.9 \text{ kJ/kg}$$

$$w_{\text{in}} = h_2 - h_1 = 440.71 - 399.04 = \mathbf{41.67 \text{ kJ/kg}}$$

$$\text{COP} = \frac{q_L}{w_{\text{in}}} = \frac{149.2 \text{ kJ/kg}}{41.67 \text{ kJ/kg}} = \mathbf{3.582}$$

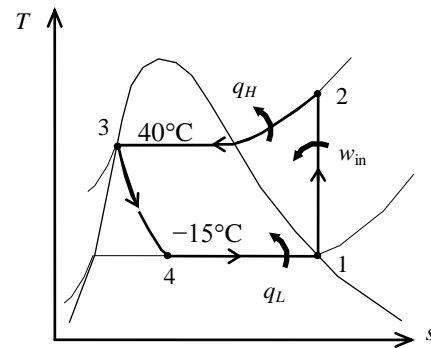

Discussion In the ideal operation, the refrigeration load decreases by 6.3% and the work input by 19.1% while the COP increases by 15.8%.

Second-Law Analysis of Vapor-Compression Refrigeration Cycles

11-24C The second-law efficiency of a refrigerator operating on the vapor-compression refrigeration cycle is defined as

$$\eta_{\text{II,R}} = \frac{\dot{X}_{\dot{Q}_L}}{\dot{W}} = \frac{\dot{W}_{\text{min}}}{\dot{W}} = 1 - \frac{\dot{X}_{\text{dest,total}}}{\dot{W}}$$

where $\dot{X}_{\dot{Q}_L}$ is the exergy of the heat transferred from the low-temperature medium and it is expressed as

$$\dot{X}_{\dot{Q}_L} = -\dot{Q}_L \left(1 - \frac{T_0}{T_L} \right)$$

$\dot{X}_{\text{dest,total}}$ is the total exergy destruction in the cycle and \dot{W} is the actual power input to the cycle. The second-law efficiency can also be expressed as the ratio of the actual COP to the Carnot COP:

$$\eta_{\text{II,R}} = \frac{\text{COP}_{\text{R}}}{\text{COP}_{\text{Carnot}}}$$

11-25C The second-law efficiency of a heat pump operating on the a vapor-compression refrigeration cycle is defined as

$$\eta_{\text{II,HP}} = \frac{\dot{E}x_{\dot{Q}_H}}{\dot{W}} = \frac{\dot{W}_{\text{min}}}{\dot{W}} = 1 - \frac{\dot{E}x_{\text{dest,total}}}{\dot{W}}$$

Substituting

$$\dot{W} = \frac{\dot{Q}_H}{\text{COP}_{\text{HP}}} \quad \text{and} \quad \dot{E}x_{\dot{Q}_H} = \dot{Q}_H \left(1 - \frac{T_0}{T_H} \right)$$

into the second-law efficiency equation

$$\eta_{\text{II,HP}} = \frac{\dot{E}x_{\dot{Q}_H}}{\dot{W}} = \frac{\dot{Q}_H \left(1 - \frac{T_0}{T_H} \right)}{\frac{\dot{Q}_H}{\text{COP}_{\text{HP}}}} = \dot{Q}_H \left(1 - \frac{T_0}{T_H} \right) \frac{\text{COP}_{\text{HP}}}{\dot{Q}_H} = \frac{\text{COP}_{\text{HP}}}{\frac{T_H}{T_H - T_L}} = \frac{\text{COP}_{\text{HP}}}{\text{COP}_{\text{Carnot}}}$$

since $T_0 = T_L$.

11-26C In an isentropic compressor, $s_2 = s_1$ and $h_{2s} = h_2$. Applying these to the two the efficiency definitions, we obtain

$$\eta_{\text{s,Comp}} = \frac{w_{\text{isen}}}{w} = \frac{h_{2s} - h_1}{h_2 - h_1} = \frac{h_2 - h_1}{h_2 - h_1} = 1 = 100\%$$

$$\eta_{\text{II,Comp}} = \frac{w_{\text{rev}}}{w} = \frac{h_2 - h_1 - T_0(s_2 - s_1)}{h_2 - h_1} = \frac{h_2 - h_1}{h_2 - h_1} = 1 = 100\%$$

Thus, the isentropic efficiency and the second-law efficiency of an isentropic compressor are both 100%.

The second-law efficiency of a compressor is not necessarily equal to its isentropic efficiency. The two definitions are different as shown in the above equations. In the calculation of isentropic efficiency, the exit enthalpy is found at the hypothetical exit state (at the exit pressure and the inlet entropy) while the second-law efficiency involves the actual exit state. The two efficiencies are usually close but different. In the special case of an isentropic compressor, the two efficiencies become equal to each other as proven above.

11-27 A vapor-compression refrigeration system is used to keep a space at a low temperature. The power input, the COP and the second-law efficiency are to be determined.

Assumptions 1 Steady operating conditions exist. 2 Kinetic and potential energy changes are negligible.

Analysis The power input is

$$\dot{W}_{\text{in}} = \dot{Q}_H - \dot{Q}_L = 5500 - 3500 = 2000 \text{ kJ/h} = (2000 \text{ kJ/h}) \left(\frac{1 \text{ kW}}{3600 \text{ kJ/h}} \right) = \mathbf{0.5556 \text{ kW}}$$

The COP is

$$\text{COP}_R = \frac{\dot{Q}_L}{\dot{W}_{\text{in}}} = \frac{(3500/3600) \text{ kW}}{0.5556 \text{ kW}} = \mathbf{1.75}$$

The COP of the Carnot cycle operating between the space and the ambient is

$$\text{COP}_{\text{Carnot}} = \frac{T_L}{T_H - T_L} = \frac{258 \text{ K}}{(298 - 258) \text{ K}} = 6.45$$

The second-law efficiency is then

$$\eta_{\text{II}} = \frac{\text{COP}_R}{\text{COP}_{\text{Carnot}}} = \frac{1.75}{6.45} = 0.271 = \mathbf{27.1\%}$$

11-28 A refrigerator is used to cool bananas at a specified rate. The rate of heat absorbed from the bananas, the COP, The minimum power input, the second-law efficiency and the exergy destruction are to be determined.

Assumptions 1 Steady operating conditions exist. 2 Kinetic and potential energy changes are negligible.

Analysis (a) The rate of heat absorbed from the bananas is

$$\dot{Q}_L = \dot{m} c_p (T_1 - T_2) = (1140 \text{ kg/h})(3.35 \text{ kJ/kg} \cdot ^\circ\text{C})(28 - 12)^\circ\text{C} = \mathbf{61,100 \text{ kJ/h}}$$

The COP is

$$\text{COP} = \frac{\dot{Q}_L}{\dot{W}_{\text{in}}} = \frac{(61,100/3600) \text{ kW}}{8.6 \text{ kW}} = \frac{16.97 \text{ kW}}{8.6 \text{ kW}} = \mathbf{1.97}$$

(b) The minimum power input is equal to the exergy of the heat transferred from the low-temperature medium:

$$\dot{E}x_{\dot{Q}_L} = -\dot{Q}_L \left(1 - \frac{T_0}{T_L} \right) = -(16.97 \text{ kW}) \left(1 - \frac{28 + 273}{20 + 273} \right) = \mathbf{0.463 \text{ kW}}$$

where the dead state temperature is taken as the inlet temperature of the eggplants ($T_0 = 28^\circ\text{C}$) and the temperature of the low-temperature medium is taken as the average temperature of bananas $T = (12+28)/2 = 20^\circ\text{C}$.

(c) The second-law efficiency of the cycle is

$$\eta_{\text{II}} = \frac{\dot{E}x_{\dot{Q}_L}}{\dot{W}_{\text{in}}} = \frac{0.463}{8.6} = 0.0539 = \mathbf{5.39\%}$$

The exergy destruction is the difference between the exergy expended (power input) and the exergy recovered (the exergy of the heat transferred from the low-temperature medium):

$$\dot{E}x_{\text{dest}} = \dot{W}_{\text{in}} - \dot{E}x_{\dot{Q}_L} = 8.6 - 0.463 = \mathbf{8.14 \text{ kW}}$$

11-29 A vapor-compression refrigeration cycle is used to keep a space at a low temperature. The power input, the mass flow rate of water in the condenser, the second-law efficiency, and the exergy destruction are to be determined.

Assumptions 1 Steady operating conditions exist. 2 Kinetic and potential energy changes are negligible.

Analysis (a) The power input is

$$\dot{W}_{\text{in}} = \frac{\dot{Q}_L}{\text{COP}} = \frac{(24,000 \text{ Btu/h}) \left(\frac{1 \text{ kW}}{3412 \text{ Btu/h}} \right)}{2.05} = \frac{7.034 \text{ kW}}{2.05} = \mathbf{3.431 \text{ kW}}$$

(b) From an energy balance on the cycle,

$$\dot{Q}_H = \dot{Q}_L + \dot{W}_{\text{in}} = 7.034 + 3.431 = 10.46 \text{ kW}$$

The mass flow rate of the water is then determined from

$$\dot{Q}_H = \dot{m} c_{pw} \Delta T_w \longrightarrow \dot{m} = \frac{\dot{Q}_H}{c_{pw} \Delta T_w} = \frac{10.46 \text{ kW}}{(4.18 \text{ kJ/kg} \cdot ^\circ\text{C})(12^\circ\text{C})} = \mathbf{0.2086 \text{ kg/s}}$$

(c) The exergy of the heat transferred from the low-temperature medium is

$$\dot{E}x_{\dot{Q}_L} = -\dot{Q}_L \left(1 - \frac{T_0}{T_L} \right) = -(7.034 \text{ kW}) \left(1 - \frac{20 + 273}{0 + 273} \right) = 0.5153 \text{ kW}$$

The second-law efficiency of the cycle is

$$\eta_{\text{II}} = \frac{\dot{E}x_{\dot{Q}_L}}{\dot{W}_{\text{in}}} = \frac{0.5153}{3.431} = 0.1502 = \mathbf{15.0\%}$$

The exergy destruction is the difference between the exergy supplied (power input) and the exergy recovered (the exergy of the heat transferred from the low-temperature medium):

$$\dot{E}x_{\text{dest}} = \dot{W}_{\text{in}} - \dot{E}x_{\dot{Q}_L} = 3.431 - 0.5153 = \mathbf{2.916 \text{ kW}}$$

Alternative Solution

The exergy efficiency can also be determined as follows:

$$\text{COP}_{\text{R,Carnot}} = \frac{T_L}{T_H - T_L} = \frac{0 + 273}{20 - 0} = 13.65$$

$$\eta_{\text{II}} = \frac{\text{COP}}{\text{COP}_{\text{R,Carnot}}} = \frac{2.05}{13.65} = 0.1502 = 15.0\%$$

The result is identical as expected.

11-30E A vapor-compression refrigeration cycle is used to keep a space at a low temperature. The mass flow rate of R-134a, the COP, the exergy destruction in each component, the second-law efficiency of the compressor, and the second-law efficiency and exergy destruction of the cycle are to be determined.

Assumptions 1 Steady operating conditions exist. 2 Kinetic and potential energy changes are negligible.

Analysis (a) The properties of R-134a are (Tables A-11E through A-13E)

$$\begin{aligned} P_1 = 20 \text{ psia} & \left\{ \begin{array}{l} h_1 = 102.74 \text{ Btu/lbm} \\ s_1 = 0.2257 \text{ Btu/lbm} \cdot \text{R} \end{array} \right. \\ x_1 = 1 & \\ P_2 = 140 \text{ psia} & \left\{ \begin{array}{l} h_2 = 131.37 \text{ Btu/lbm} \\ s_2 = 0.2444 \text{ Btu/lbm} \cdot \text{R} \end{array} \right. \\ T_2 = 160^\circ\text{F} & \\ P_3 = 140 \text{ psia} & \left\{ \begin{array}{l} h_3 = 45.31 \text{ Btu/lbm} \\ s_3 = 0.09215 \text{ Btu/lbm} \cdot \text{R} \end{array} \right. \\ x_3 = 0 & \\ h_4 = h_3 = 45.31 \text{ Btu/lbm} & \\ P_4 = 20 \text{ psia} & \left. \right\} s_4 = 0.1001 \text{ Btu/lbm} \cdot \text{R} \\ h_4 = 45.31 \text{ Btu/lbm} & \end{aligned}$$

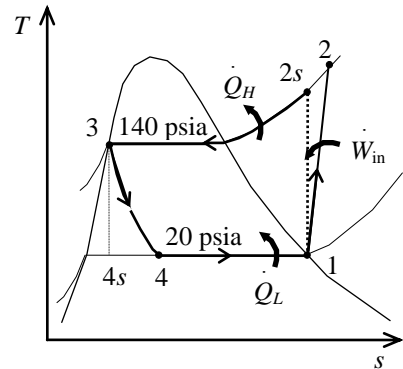

The energy interactions in each component and the mass flow rate of R-134a are

$$w_{\text{in}} = h_2 - h_1 = 131.37 - 102.74 = 28.63 \text{ Btu/lbm}$$

$$q_H = h_2 - h_3 = 131.37 - 45.31 = 86.06 \text{ Btu/lbm}$$

$$q_L = q_H - w_{\text{in}} = 86.06 - 28.63 = 57.43 \text{ Btu/lbm}$$

$$\dot{m} = \frac{\dot{Q}_L}{q_L} = \frac{(45,000/3600) \text{ Btu/s}}{57.43 \text{ Btu/lbm}} = \mathbf{0.2177 \text{ lbm/s}}$$

The COP is

$$\text{COP} = \frac{q_L}{w_{\text{in}}} = \frac{57.43 \text{ Btu/lbm}}{28.63 \text{ Btu/lbm}} = \mathbf{2.006}$$

(b) The exergy destruction in each component of the cycle is determined as follows:

Compressor:

$$s_{\text{gen},1-2} = s_2 - s_1 = 0.2444 - 0.2257 = 0.01874 \text{ Btu/lbm} \cdot \text{R}$$

$$\dot{E}x_{\text{dest},1-2} = \dot{m}T_0 s_{\text{gen},1-2} = (0.2177 \text{ lbm/s})(540 \text{ R})(0.01874 \text{ Btu/lbm} \cdot \text{R}) = \mathbf{2.203 \text{ Btu/s}}$$

Condenser:

$$s_{\text{gen},2-3} = s_3 - s_2 + \frac{q_H}{T_H} = (0.09215 - 0.2444) \text{ Btu/lbm} \cdot \text{R} + \frac{86.06 \text{ Btu/lbm}}{540 \text{ R}} = 0.007073 \text{ Btu/lbm} \cdot \text{R}$$

$$\dot{E}x_{\text{dest},2-3} = \dot{m}T_0 s_{\text{gen},2-3} = (0.2177 \text{ lbm/s})(540 \text{ R})(0.007073 \text{ Btu/lbm} \cdot \text{R}) = \mathbf{0.8313 \text{ Btu/s}}$$

Expansion valve:

$$s_{\text{gen},3-4} = s_4 - s_3 = 0.1001 - 0.09215 = 0.007961 \text{ Btu/lbm} \cdot \text{R}$$

$$\dot{E}x_{\text{dest},3-4} = \dot{m}T_0 s_{\text{gen},3-4} = (0.2177 \text{ lbm/s})(540 \text{ R})(0.007961 \text{ Btu/lbm} \cdot \text{R}) = \mathbf{0.9358 \text{ Btu/s}}$$

Evaporator:

$$s_{\text{gen},4-1} = s_1 - s_4 - \frac{q_L}{T_L} = (0.2257 - 0.1001) \text{ Btu/lbm} \cdot \text{R} - \frac{57.43 \text{ Btu/lbm}}{470 \text{ R}} = 0.003400 \text{ Btu/lbm} \cdot \text{R}$$

$$\dot{E}x_{\text{dest},41} = \dot{m}T_0s_{\text{gen},41} = (0.2177 \text{ lbm/s})(540 \text{ R})(0.003400 \text{ Btu/lbm} \cdot \text{R}) = \mathbf{0.3996 \text{ Btu/s}}$$

The power input and the second-law efficiency of the compressor is determined from

$$\dot{W}_{\text{in}} = \dot{m}w_{\text{in}} = (0.2177 \text{ lbm/s})(28.63 \text{ Btu/lbm}) = 6.232 \text{ Btu/s}$$

$$\eta_{\text{II}} = 1 - \frac{\dot{E}x_{\text{dest},1-2}}{\dot{W}_{\text{in}}} = 1 - \frac{2.203 \text{ Btu/s}}{6.232 \text{ Btu/s}} = 0.6465 = \mathbf{64.7\%}$$

(c) The exergy of the heat transferred from the low-temperature medium is

$$\dot{E}x_{\dot{Q}_L} = -\dot{Q}_L \left(1 - \frac{T_0}{T_L} \right) = -(45000 / 3600 \text{ Btu/s}) \left(1 - \frac{540}{470} \right) = 1.862 \text{ Btu/s}$$

The second-law efficiency of the cycle is

$$\eta_{\text{II}} = \frac{\dot{E}x_{\dot{Q}_L}}{\dot{W}_{\text{in}}} = \frac{1.862 \text{ Btu/s}}{6.232 \text{ Btu/s}} = 0.2988 = \mathbf{29.9\%}$$

The total exergy destruction in the cycle is the difference between the exergy supplied (power input) and the exergy recovered (the exergy of the heat transferred from the low-temperature medium):

$$\dot{E}x_{\text{dest,total}} = \dot{W}_{\text{in}} - \dot{E}x_{\dot{Q}_L} = 6.232 - 1.862 = \mathbf{4.370 \text{ Btu/s}}$$

The total exergy destruction can also be determined by adding exergy destructions in each component:

$$\begin{aligned} \dot{E}x_{\text{dest,total}} &= \dot{E}x_{\text{dest},1-2} + \dot{E}x_{\text{dest},2-3} + \dot{E}x_{\text{dest},3-4} + \dot{E}x_{\text{dest},4-1} \\ &= 2.203 + 0.8313 + 0.9358 + 0.3996 \\ &= 4.370 \text{ Btu/s} \end{aligned}$$

The result is the same as expected.

11-31 A vapor-compression refrigeration cycle is used to keep a space at a low temperature. The mass flow rate of R-134a, the COP, The exergy destruction in each component and the exergy efficiency of the compressor, the second-law efficiency, and the exergy destruction are to be determined.

Assumptions 1 Steady operating conditions exist. **2** Kinetic and potential energy changes are negligible.

Analysis (a) The properties of R-134a are (Tables A-11 through A-13)

$$\begin{aligned} P_2 = 1.2 \text{ MPa} & \left\{ \begin{array}{l} h_2 = 278.28 \text{ kJ/kg} \\ s_2 = 0.9268 \text{ kJ/kg} \cdot \text{K} \end{array} \right. \\ T_2 = 50^\circ\text{C} & \\ P_3 = 1.2 \text{ MPa} & \left\{ \begin{array}{l} h_3 = 117.79 \text{ kJ/kg} \\ s_3 = 0.4245 \text{ kJ/kg} \cdot \text{K} \end{array} \right. \\ x_3 = 0 & \end{aligned}$$

The rate of heat transferred to the water is the energy change of the water from inlet to exit

$$\dot{Q}_H = \dot{m}_w c_p (T_{w,2} - T_{w,1}) = (0.13 \text{ kg/s})(4.18 \text{ kJ/kg} \cdot ^\circ\text{C})(28 - 20)^\circ\text{C} = 4.347 \text{ kW}$$

The energy decrease of the refrigerant is equal to the energy increase of the water in the condenser. That is,

$$\dot{Q}_H = \dot{m}_R (h_2 - h_3) \longrightarrow \dot{m}_R = \frac{\dot{Q}_H}{h_2 - h_3} = \frac{4.347 \text{ kW}}{(278.28 - 117.79) \text{ kJ/kg}} = 0.02709 \text{ kg/s}$$

The refrigeration load is

$$\dot{Q}_L = \dot{Q}_H - \dot{W}_{\text{in}} = 4.347 - 1.9 = 2.447 \text{ kW} = (2.447 \text{ kW}) \left(\frac{3412 \text{ Btu/h}}{1 \text{ kW}} \right) = \mathbf{8350 \text{ Btu/h}}$$

The COP of the refrigerator is determined from its definition,

$$\text{COP} = \frac{\dot{Q}_L}{\dot{W}_{\text{in}}} = \frac{2.447 \text{ kW}}{1.9 \text{ kW}} = \mathbf{1.29}$$

(b) The COP of a reversible refrigerator operating between the same temperature limits is

$$\text{COP}_{\text{Carnot}} = \frac{T_L}{T_H - T_L} = \frac{-5 + 273}{(20 + 273) - (-5 + 273)} = 10.72$$

The minimum power input to the compressor for the same refrigeration load would be

$$\dot{W}_{\text{in,min}} = \frac{\dot{Q}_L}{\text{COP}_{\text{Carnot}}} = \frac{2.447 \text{ kW}}{10.72} = 0.2283 \text{ kW}$$

The second-law efficiency of the cycle is

$$\eta_{\text{II}} = \frac{\dot{W}_{\text{in,min}}}{\dot{W}_{\text{in}}} = \frac{0.2283}{1.9} = 0.120 = \mathbf{12.0\%}$$

The total exergy destruction in the cycle is the difference between the actual and the minimum power inputs:

$$\dot{E}x_{\text{dest,total}} = \dot{W}_{\text{in}} - \dot{W}_{\text{in,min}} = 1.9 - 0.2283 = \mathbf{1.67 \text{ kW}}$$

(c) The entropy generation in the condenser is

$$\begin{aligned} \dot{S}_{\text{gen,cond}} &= \dot{m}_w c_p \ln \left(\frac{T_{w,2}}{T_{w,1}} \right) + \dot{m}_R (s_3 - s_2) \\ &= (0.13 \text{ kg/s})(4.18 \text{ kJ/kg} \cdot ^\circ\text{C}) \ln \left(\frac{28 + 273}{20 + 273} \right) + (0.02709 \text{ kg/s})(0.4245 - 0.9268) \text{ kJ/kg} \cdot \text{K} \\ &= 0.001032 \text{ kW/K} \end{aligned}$$

The exergy destruction in the condenser is

$$\dot{E}x_{\text{dest,cond}} = T_0 \dot{S}_{\text{gen,cond}} = (293 \text{ K})(0.001032 \text{ kW/K}) = \mathbf{0.303 \text{ kW}}$$

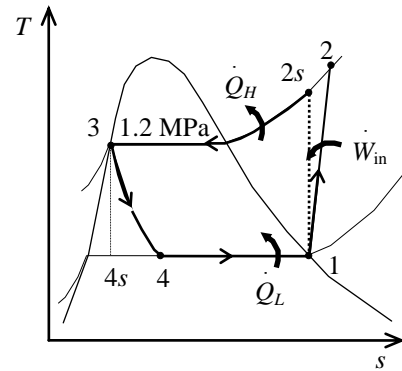

11-32 An ideal vapor-compression refrigeration cycle is used to keep a space at a low temperature. The cooling load, the COP, the exergy destruction in each component, the total exergy destruction, and the second-law efficiency are to be determined.

Assumptions 1 Steady operating conditions exist. 2 Kinetic and potential energy changes are negligible.

Analysis (a) The properties of R-134a are (Tables A-11 through A-13)

$$\left. \begin{aligned} T_1 &= -10^\circ\text{C} \\ x_1 &= 1 \end{aligned} \right\} \begin{aligned} h_1 &= 244.55 \text{ kJ/kg} \\ s_1 &= 0.9378 \text{ kJ/kg}\cdot\text{K} \end{aligned}$$

$$\left. \begin{aligned} P_2 &= P_{\text{sat}@57.9^\circ\text{C}} = 1600 \text{ kPa} \\ s_2 &= s_1 \end{aligned} \right\} \begin{aligned} h_2 &= 287.89 \text{ kJ/kg} \\ s_2 &= 0.9378 \text{ kJ/kg}\cdot\text{K} \end{aligned}$$

$$\left. \begin{aligned} P_3 &= 1600 \text{ kPa} \\ x_3 &= 0 \end{aligned} \right\} \begin{aligned} h_3 &= 135.96 \text{ kJ/kg} \\ s_3 &= 0.4792 \text{ kJ/kg}\cdot\text{K} \end{aligned}$$

$$h_4 = h_3 = 135.96 \text{ kJ/kg}$$

$$\left. \begin{aligned} T_4 &= -10^\circ\text{C} \\ h_4 &= 135.96 \text{ kJ/kg} \end{aligned} \right\} s_4 = 0.5252 \text{ kJ/kg}\cdot\text{K}$$

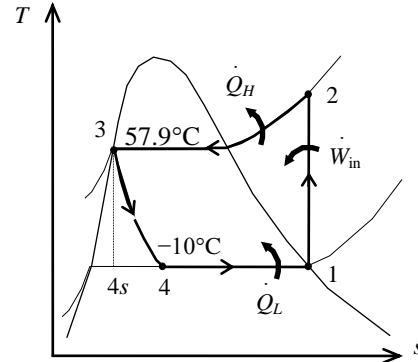

The energy interactions in the components and the COP are

$$q_L = h_1 - h_4 = 244.55 - 135.96 = \mathbf{108.6 \text{ kJ/kg}}$$

$$q_H = h_2 - h_3 = 287.89 - 135.96 = 151.9 \text{ kJ/kg}$$

$$w_{\text{in}} = h_2 - h_1 = 287.89 - 244.55 = 43.34 \text{ kJ/kg}$$

$$\text{COP} = \frac{q_L}{w_{\text{in}}} = \frac{108.6 \text{ kJ/kg}}{43.34 \text{ kJ/kg}} = \mathbf{2.506}$$

(b) The exergy destruction in each component of the cycle is determined as follows

Compressor:

$$s_{\text{gen},1-2} = s_2 - s_1 = 0$$

$$Ex_{\text{dest},1-2} = T_0 s_{\text{gen},1-2} = \mathbf{0}$$

Condenser:

$$s_{\text{gen},2-3} = s_3 - s_2 + \frac{q_H}{T_H} = (0.4792 - 0.9378) \text{ kJ/kg}\cdot\text{K} + \frac{151.9 \text{ kJ/kg}}{298 \text{ K}} = 0.05125 \text{ kJ/kg}\cdot\text{K}$$

$$Ex_{\text{dest},2-3} = T_0 s_{\text{gen},2-3} = (298 \text{ K})(0.05125 \text{ kJ/kg}\cdot\text{K}) = \mathbf{15.27 \text{ kJ/kg}}$$

Expansion valve:

$$s_{\text{gen},3-4} = s_4 - s_3 = 0.5252 - 0.4792 = 0.04595 \text{ kJ/kg}\cdot\text{K}$$

$$Ex_{\text{dest},3-4} = T_0 s_{\text{gen},3-4} = (298 \text{ K})(0.04595 \text{ kJ/kg}\cdot\text{K}) = \mathbf{13.69 \text{ kJ/kg}}$$

Evaporator:

$$s_{\text{gen},4-1} = s_1 - s_4 - \frac{q_L}{T_L} = (0.9378 - 0.5252) \text{ kJ/kg}\cdot\text{K} - \frac{108.6 \text{ kJ/kg}}{278 \text{ K}} = 0.02202 \text{ kJ/kg}\cdot\text{K}$$

$$Ex_{\text{dest},4-1} = T_0 s_{\text{gen},4-1} = (298 \text{ K})(0.02202 \text{ kJ/kg}\cdot\text{K}) = \mathbf{6.56 \text{ kJ/kg}}$$

The total exergy destruction can be determined by adding exergy destructions in each component:

$$\begin{aligned}\dot{E}x_{\text{dest,total}} &= \dot{E}x_{\text{dest},1,2} + \dot{E}x_{\text{dest},2,3} + \dot{E}x_{\text{dest},3,4} + \dot{E}x_{\text{dest},4,1} \\ &= 0 + 15.27 + 13.69 + 6.56 \\ &= \mathbf{35.52 \text{ kJ/kg}}\end{aligned}$$

(c) The exergy of the heat transferred from the low-temperature medium is

$$Ex_{q_L} = -q_L \left(1 - \frac{T_0}{T_L} \right) = -(108.6 \text{ kJ/kg}) \left(1 - \frac{298}{278} \right) = 7.813 \text{ kJ/kg}$$

The second-law efficiency of the cycle is

$$\eta_{\text{II}} = \frac{Ex_{q_L}}{w_{\text{in}}} = \frac{7.813}{43.34} = 0.180 = \mathbf{18.0\%}$$

The total exergy destruction in the cycle can also be determined from

$$E\dot{x}_{\text{dest,total}} = w_{\text{in}} - Ex_{q_L} = 43.34 - 7.813 = 35.53 \text{ kJ/kg}$$

The result is practically identical as expected.

The second-law efficiency of the compressor is determined from

$$\eta_{\text{II,Comp}} = \frac{\dot{X}_{\text{recovered}}}{\dot{X}_{\text{expended}}} = \frac{\dot{W}_{\text{rev}}}{\dot{W}_{\text{act,in}}} = \frac{\dot{m}[h_2 - h_1 - T_0(s_2 - s_1)]}{\dot{m}(h_2 - h_1)}$$

since the compression through the compressor is isentropic ($s_2 = s_1$), the second-law efficiency is

$$\eta_{\text{II,Comp}} = 1 = \mathbf{100\%}$$

The second-law efficiency of the evaporator is determined from

$$\eta_{\text{II,Evap}} = \frac{\dot{X}_{\text{recovered}}}{\dot{X}_{\text{expended}}} = \frac{\dot{Q}_L(T_0 - T_L)/T_L}{\dot{m}[h_4 - h_1 - T_0(s_4 - s_1)]} = 1 - \frac{\dot{X}_{\text{dest},4,1}}{\dot{X}_4 - \dot{X}_1}$$

where

$$\begin{aligned}x_4 - x_1 &= h_4 - h_1 - T_0(s_4 - s_1) \\ &= (135.96 - 244.55) \text{ kJ/kg} - (298 \text{ K})(0.5252 - 0.9378) \text{ kJ/kg} \cdot \text{K} \\ &= 14.37 \text{ kJ/kg}\end{aligned}$$

Substituting,

$$\eta_{\text{II,Evap}} = 1 - \frac{x_{\text{dest},4,1}}{x_4 - x_1} = 1 - \frac{6.56 \text{ kJ/kg}}{14.37 \text{ kJ/kg}} = 0.544 = \mathbf{54.4\%}$$

11-33 An ideal vapor-compression refrigeration cycle uses ammonia as the refrigerant. The volume flow rate at the compressor inlet, the power input, the COP, the second-law efficiency and the total exergy destruction are to be determined.

Assumptions 1 Steady operating conditions exist. 2 Kinetic and potential energy changes are negligible.

Analysis (a) The properties of ammonia are given in problem statement. An energy balance on the condenser gives

$$q_H = h_1 - h_4 = 1439.3 - 437.4 = 1361 \text{ kJ/kg}$$

$$\dot{m} = \frac{\dot{Q}_H}{q_H} = \frac{18 \text{ kW}}{1361 \text{ kJ/kg}} = 0.01323 \text{ kg/s}$$

The volume flow rate is determined from

$$\begin{aligned} \dot{V}_1 &= \dot{m}v_1 = (0.01323 \text{ kg/s})(0.5946 \text{ m}^3/\text{kg}) \\ &= 0.007865 \text{ m}^3/\text{s} = \mathbf{7.87 \text{ L/s}} \end{aligned}$$

(b) The power input and the COP are

$$\dot{W}_{\text{in}} = \dot{m}(h_2 - h_1) = (0.01323 \text{ kg/s})(1798.3 - 1439.3) \text{ kJ/kg} = \mathbf{4.75 \text{ kW}}$$

$$\dot{Q}_L = \dot{m}(h_1 - h_4) = (0.01323 \text{ kg/s})(1439.3 - 437.4) \text{ kJ/kg} = 13.25 \text{ kW}$$

$$\text{COP} = \frac{\dot{Q}_L}{\dot{W}_{\text{in}}} = \frac{13.25 \text{ kW}}{4.75 \text{ kW}} = \mathbf{2.79}$$

(c) The exergy of the heat transferred from the low-temperature medium is

$$\dot{E}x_{\dot{Q}_L} = -\dot{Q}_L \left(1 - \frac{T_0}{T_L} \right) = -(13.25 \text{ kW}) \left(1 - \frac{300}{264} \right) = 1.81 \text{ kW}$$

The second-law efficiency of the cycle is

$$\eta_{\text{II}} = \frac{\dot{E}x_{\dot{Q}_L}}{\dot{W}_{\text{in}}} = \frac{1.81}{4.75} = 0.381 = \mathbf{38.1\%}$$

The total exergy destruction in the cycle is the difference between the exergy supplied (power input) and the exergy recovered (the exergy of the heat transferred from the low-temperature medium):

$$\dot{E}x_{\text{dest,total}} = \dot{W}_{\text{in}} - \dot{E}x_{\dot{Q}_L} = 4.75 - 1.81 = \mathbf{2.94 \text{ kW}}$$

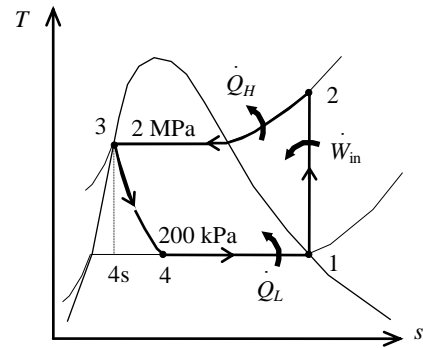



11-34 Prob. 11-33 is reconsidered. Using EES software, the problem is to be repeated ammonia, R-134a and R-22 is used as a refrigerant and the effects of evaporator and condenser pressures on the COP, the second-law efficiency and the total exergy destruction are to be investigated.

Analysis The equations as written in EES are

"GIVEN"

P_1=200 [kPa]
 P_2=2000 [kPa]
 Q_dot_H=18 [kW]
 T_L=(-9+273) [K]
 T_H=(27+273) [K]

"PROPERTIES"

Fluid\$='ammonia'
 x_1=1
 x_3=0
 h_1=enthalpy(Fluid\$, P=P_1, x=x_1)
 s_1=entropy(Fluid\$, P=P_1, x=x_1)
 v_1=volume(Fluid\$, P=P_1, x=x_1)
 h_2=enthalpy(Fluid\$, P=P_2, s=s_1)
 s_2=s_1
 h_3=enthalpy(Fluid\$, P=P_2, x=x_3)
 s_3=entropy(Fluid\$, P=P_2, x=x_3)
 h_4=h_3
 s_4=entropy(Fluid\$, P=P_1, h=h_4)

q_H=h_2-h_3
 m_dot=Q_dot_H/q_H
 Vol_dot_1=m_dot*v_1
 Q_dot_L=m_dot*(h_1-h_4)
 W_dot_in=m_dot*(h_2-h_1)
 COP=Q_dot_L/W_dot_in
 Ex_dot_QL=-Q_dot_L*(1-T_H/T_L)
 eta_II=Ex_dot_QL/W_dot_in
 Ex_dot_dest=W_dot_in-Ex_dot_QL

```

"GIVEN"
P_1=200 [kPa]
P_2=2000 [kPa]
Q_dot_H=18 [kW]
T_L=(-9+273) [K]
T_H=(27+273) [K]

"PROPERTIES"
Fluid$='ammonia'
x_1=1
x_3=0
h_1=enthalpy(Fluid$, P=P_1, x=x_1)
s_1=entropy(Fluid$, P=P_1, x=x_1)
v_1=volume(Fluid$, P=P_1, x=x_1)
h_2=enthalpy(Fluid$, P=P_2, s=s_1)
s_2=s_1
h_3=enthalpy(Fluid$, P=P_2, x=x_3)
s_3=entropy(Fluid$, P=P_2, x=x_3)
h_4=h_3
s_4=entropy(Fluid$, P=P_1, h=h_4)

q_H=h_2-h_3
m_dot=Q_dot_H/q_H
Vol_dot_1=m_dot*v_1
Q_dot_L=m_dot*(h_1-h_4)
W_dot_in=m_dot*(h_2-h_1)
COP=Q_dot_L/W_dot_in
Ex_dot_QL=-Q_dot_L*(1-T_H/T_L)
eta_II=Ex_dot_QL/W_dot_in
Ex_dot_dest=W_dot_in-Ex_dot_QL
  
```

The solutions in the case of ammonia, R-134a and R-22 are

Unit Settings: [kJ]/[C]/[kPa]/[kg]/[degrees]	
COP = 2.791	$\eta_{II} = 0.3805$
$\dot{E}x_{dest} = 2.941$ [kW]	$\dot{E}x_{QL} = 1.807$ [kW]
Fluid\$ = 'ammonia'	$h_1 = 1439.25$ [kJ/kg]
$h_2 = 1798.26$ [kJ/kg]	$h_3 = 437.39$ [kJ/kg]
$h_4 = 437.39$ [kJ/kg]	$\dot{m} = 0.01323$ [kg/s]
$P_1 = 200$ [kPa]	$P_2 = 2000$ [kPa]
$\dot{Q}_H = 18$ [kW]	$\dot{Q}_L = 13.252$ [kW]
$q_H = 1361$ [kJ/kg]	$s_1 = 5.8865$ [kJ/kg-K]
$s_2 = 5.8865$ [kJ/kg-K]	$s_3 = 1.7892$ [kJ/kg-K]
$s_4 = 1.9469$ [kJ/kg-K]	$T_H = 300$ [K]
$T_L = 264$ [K]	$Vol_1 = 0.007865$ [m ³ /s]
$v_1 = 0.5946$ [m ³ /kg]	$\dot{W}_{in} = 4.748$ [kW]
$x_1 = 1$	$x_3 = 0$

No unit problems were detected.
 Calculation time = .0 sec

Unit Settings: [kJ]/[C]/[kPa]/[kg]/[degrees]	
COP = 1.931	$\eta_{II} = 0.2633$
$\dot{E}x_{dest} = 4.524$ [kW]	$\dot{E}x_{QL} = 1.617$ [kW]
Fluid\$ = 'R134a'	$h_1 = 244.46$ [kJ/kg]
$h_2 = 292.46$ [kJ/kg]	$h_3 = 151.76$ [kJ/kg]
$h_4 = 151.76$ [kJ/kg]	$\dot{m} = 0.1279$ [kg/s]
$P_1 = 200$ [kPa]	$P_2 = 2000$ [kPa]
$\dot{Q}_H = 18$ [kW]	$\dot{Q}_L = 11.859$ [kW]
$q_H = 140.7$ [kJ/kg]	$s_1 = 0.9377$ [kJ/kg-K]
$s_2 = 0.9377$ [kJ/kg-K]	$s_3 = 0.5251$ [kJ/kg-K]
$s_4 = 0.5854$ [kJ/kg-K]	$T_H = 300$ [K]
$T_L = 264$ [K]	$Vol_1 = 0.01278$ [m ³ /s]
$v_1 = 0.09987$ [m ³ /kg]	$\dot{W}_{in} = 6.141$ [kW]
$x_1 = 1$	$x_3 = 0$

No unit problems were detected.
 Calculation time = .0 sec

Solution

Unit Settings: [kJ]/[C]/[kPa]/[kg]/[degrees]

COP = 2.164 $\eta_{II} = 0.2951$
 $\dot{E}x_{dest} = 4.01$ [kW] $\dot{E}x_{QL} = 1.679$ [kW]
 Fluid\$ = 'R22'
 $h_2 = 454.51$ [kJ/kg] $h_3 = 265.17$ [kJ/kg]
 $h_4 = 265.17$ [kJ/kg] $\dot{m} = 0.09507$ [kg/s]
 $P_1 = 200$ [kPa] $P_2 = 2000$ [kPa]
 $\dot{Q}_H = 18$ [kW] $\dot{Q}_L = 12.311$ [kW]
 $q_H = 189.3$ [kJ/kg] $s_1 = 1.7915$ [kJ/kg-K]
 $s_2 = 1.7915$ [kJ/kg-K] $s_3 = 1.2139$ [kJ/kg-K]
 $s_4 = 1.2693$ [kJ/kg-K] $T_H = 300$ [K]
 $T_L = 264$ [K] $Vol_1 = 0.01068$ [m³/s]
 $v_1 = 0.1123$ [m³/kg] $\dot{W}_m = 5.689$ [kW]
 $x_1 = 1$ $x_3 = 0$

No unit problems were detected.

Calculation time = .0 sec

Now, we investigate the effects of evaporating and condenser pressures on the COP, the second-law efficiency and the total exergy destruction. The results are given by tables and figures.

Parametric Table

1..13	P_1 [kPa]	COP	η_{II}	$\dot{E}x_{dest}$ [kW]
Run 1	100	2.008	0.2739	4.345
Run 2	125	2.216	0.3022	3.906
Run 3	150	2.413	0.3291	3.538
Run 4	175	2.604	0.3551	3.221
Run 5	200	2.791	0.3805	2.941
Run 6	225	2.975	0.4056	2.692
Run 7	250	3.157	0.4306	2.466
Run 8	275	3.34	0.4554	2.259
Run 9	300	3.523	0.4804	2.068
Run 10	325	3.707	0.5055	1.891
Run 11	350	3.893	0.5308	1.726
Run 12	375	4.081	0.5564	1.572
Run 13	400	4.271	0.5825	1.426

Parametric Table

1..11	P_2 [kPa]	COP	η_{II}	$\dot{E}x_{dest}$ [kW]
Run 1	1000	4.851	0.6615	1.041
Run 2	1100	4.468	0.6093	1.286
Run 3	1200	4.154	0.5665	1.514
Run 4	1300	3.891	0.5306	1.727
Run 5	1400	3.667	0.5001	1.928
Run 6	1500	3.473	0.4737	2.118
Run 7	1600	3.304	0.4505	2.298
Run 8	1700	3.154	0.4301	2.47
Run 9	1800	3.02	0.4118	2.634
Run 10	1900	2.9	0.3954	2.791
Run 11	2000	2.791	0.3805	2.941

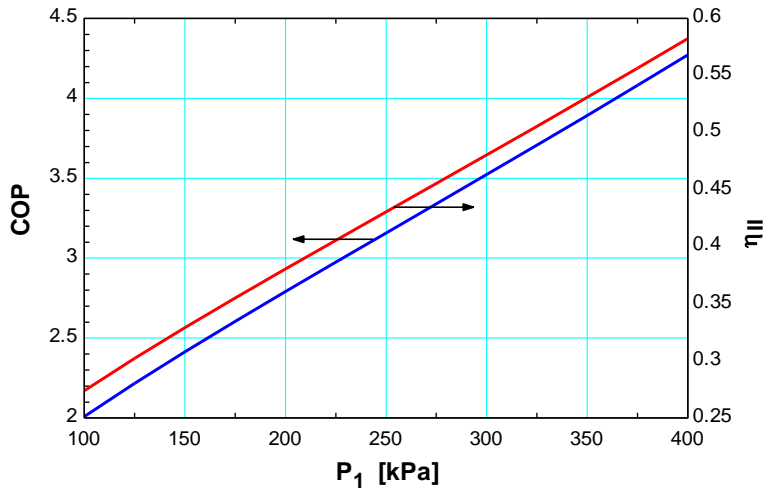

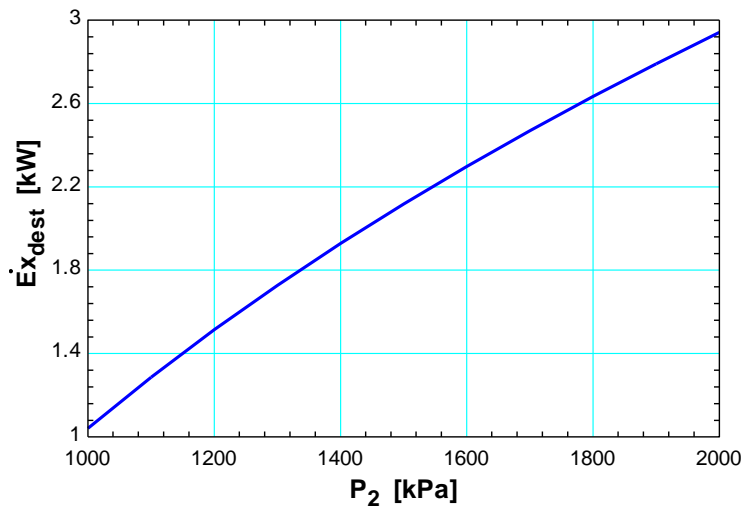
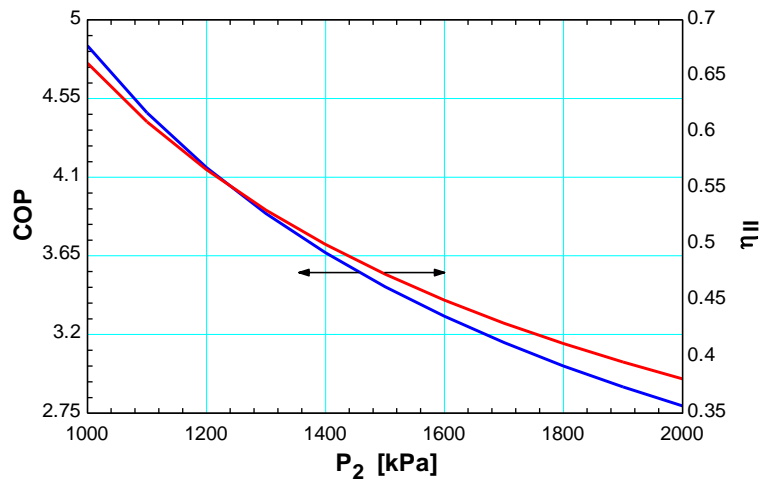
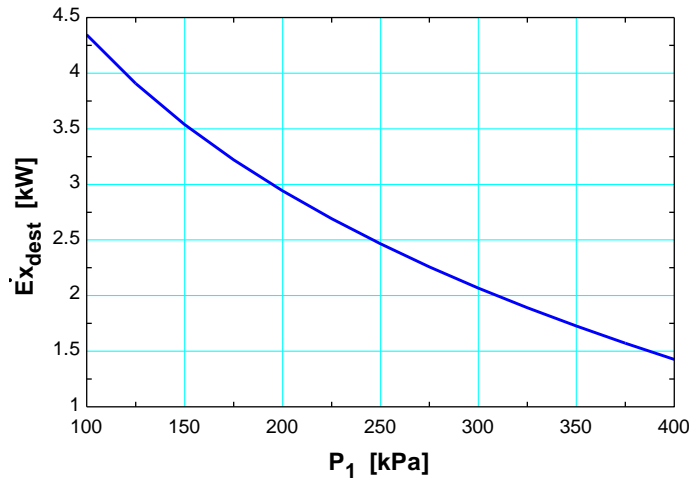

Selecting the Right Refrigerant

11-35C The desirable characteristics of a refrigerant are to have an evaporator pressure which is above the atmospheric pressure, and a condenser pressure which corresponds to a saturation temperature above the temperature of the cooling medium. Other desirable characteristics of a refrigerant include being nontoxic, noncorrosive, nonflammable, chemically stable, having a high enthalpy of vaporization (minimizes the mass flow rate) and, of course, being available at low cost.

11-36C The minimum pressure that the refrigerant needs to be compressed to is the saturation pressure of the refrigerant at 30°C, which is **0.771 MPa**. At lower pressures, the refrigerant will have to condense at temperatures lower than the temperature of the surroundings, which cannot happen.

11-37C Allowing a temperature difference of 10°C for effective heat transfer, the evaporation temperature of the refrigerant should be -20°C. The saturation pressure corresponding to -20°C is 0.133 MPa. Therefore, the recommended pressure would be 0.12 MPa.

11-38 A refrigerator that operates on the ideal vapor-compression cycle with refrigerant-134a is considered. Reasonable pressures for the evaporator and the condenser are to be selected.

Assumptions **1** Steady operating conditions exist. **2** Kinetic and potential energy changes are negligible.

Analysis Allowing a temperature difference of 10°C for effective heat transfer, the evaporation and condensation temperatures of the refrigerant should be -20°C and 35°C, respectively. The saturation pressures corresponding to these temperatures are 0.133 MPa and 0.888 MPa. Therefore, the recommended evaporator and condenser pressures are **0.133 MPa** and **0.888 MPa**, respectively.

11-39 A heat pump that operates on the ideal vapor-compression cycle with refrigerant-134a is considered. Reasonable pressures for the evaporator and the condenser are to be selected.

Assumptions **1** Steady operating conditions exist. **2** Kinetic and potential energy changes are negligible.

Analysis Allowing a temperature difference of 10°C for effective heat transfer, the evaporation and condensation temperatures of the refrigerant should be 4°C and 36°C, respectively. The saturation pressures corresponding to these temperatures are 338 kPa and 912 kPa. Therefore, the recommended evaporator and condenser pressures are **338 kPa** and **912 kPa**, respectively.

Heat Pump Systems

11-40C A heat pump system is more cost effective in Miami because of the low heating loads and high cooling loads at that location.

11-41C A water-source heat pump extracts heat from water instead of air. Water-source heat pumps have higher COPs than the air-source systems because the temperature of water is higher than the temperature of air in winter.

11-42 A heat pump that operates on the ideal vapor-compression cycle with refrigerant-134a is considered. The power input to the heat pump is to be determined.

Assumptions 1 Steady operating conditions exist. 2 Kinetic and potential energy changes are negligible.

Analysis In an ideal vapor-compression refrigeration cycle, the compression process is isentropic, the refrigerant enters the compressor as a saturated vapor at the evaporator pressure, and leaves the condenser as saturated liquid at the condenser pressure. From the refrigerant tables (Tables A-12 and A-13),

$$P_1 = 320 \text{ kPa} \left\{ \begin{array}{l} h_1 = h_g @ 320 \text{ kPa} = 251.93 \text{ kJ/kg} \\ \text{sat. vapor} \quad \left. \begin{array}{l} s_1 = s_g @ 320 \text{ kPa} = 0.93026 \text{ kJ/kg} \cdot \text{K} \end{array} \right\} \end{array} \right.$$

$$P_2 = 1.4 \text{ MPa} \left\{ \begin{array}{l} h_2 = 282.60 \text{ kJ/kg} \\ s_2 = s_1 \end{array} \right.$$

$$P_3 = 1.4 \text{ MPa} \left\{ \begin{array}{l} h_3 = h_f @ 1.4 \text{ MPa} = 127.25 \text{ kJ/kg} \\ \text{sat. liquid} \end{array} \right.$$

$$h_4 \cong h_3 = 127.25 \text{ kJ/kg} \quad (\text{throttling})$$

The heating load of this heat pump is determined from

$$\begin{aligned} \dot{Q}_H &= [\dot{m}c(T_2 - T_1)]_{\text{water}} \\ &= (0.12 \text{ kg/s})(4.18 \text{ kJ/kg} \cdot ^\circ\text{C})(45 - 15)^\circ\text{C} \\ &= 15.05 \text{ kW} \end{aligned}$$

and

$$\dot{m}_R = \frac{\dot{Q}_H}{q_H} = \frac{\dot{Q}_H}{h_2 - h_3} = \frac{15.05 \text{ kJ/s}}{(282.60 - 127.25) \text{ kJ/kg}} = 0.09686 \text{ kg/s}$$

Then,

$$\dot{W}_{\text{in}} = \dot{m}_R(h_2 - h_1) = (0.09686 \text{ kg/s})(282.60 - 251.93) \text{ kJ/kg} = \mathbf{2.97 \text{ kW}}$$

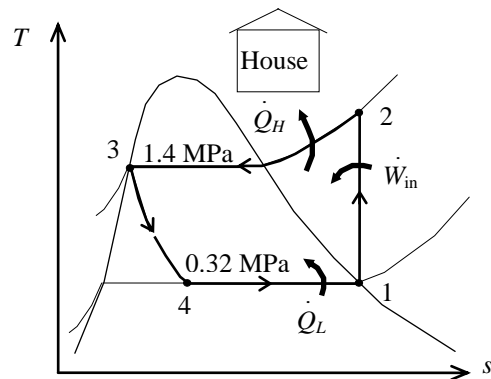

11-43 A geothermal heat pump is considered. The degrees of subcooling done on the refrigerant in the condenser, the mass flow rate of the refrigerant, the heating load, the COP of the heat pump, the minimum power input are to be determined.

Assumptions 1 Steady operating conditions exist. 2 Kinetic and potential energy changes are negligible.

Analysis (a) From the refrigerant-134a tables (Tables A-11 through A-13)

$$\begin{aligned} T_4 = 20^\circ\text{C} \left. \begin{array}{l} P_4 = 572.1 \text{ kPa} \\ x_4 = 0.23 \end{array} \right\} h_4 = 121.25 \text{ kJ/kg} \\ h_3 = h_4 = 121.25 \text{ kJ/kg} \\ P_1 = 572.1 \text{ kPa} \left. \begin{array}{l} h_1 = 261.64 \text{ kJ/kg} \\ x_1 = 1 \text{ (sat. vap.)} \end{array} \right\} s_1 = 0.9225 \text{ kJ/kg} \\ P_2 = 1400 \text{ kPa} \left. \begin{array}{l} h_2 = 280.05 \text{ kJ/kg} \\ s_2 = s_1 \end{array} \right\} \end{aligned}$$

From the steam tables (Table A-4)

$$\begin{aligned} h_{w1} &= h_f @ 50^\circ\text{C} = 209.34 \text{ kJ/kg} \\ h_{w2} &= h_f @ 40^\circ\text{C} = 167.53 \text{ kJ/kg} \end{aligned}$$

The saturation temperature at the condenser pressure of 1400 kPa and the actual temperature at the condenser outlet are

$$\begin{aligned} T_{\text{sat @ 1400 kPa}} &= 52.40^\circ\text{C} \\ P_3 = 1400 \text{ kPa} \left. \begin{array}{l} h_3 = 121.25 \text{ kJ/kg} \end{array} \right\} T_3 &= 48.58^\circ\text{C} \text{ (from EES)} \end{aligned}$$

Then, the degrees of subcooling is

$$\Delta T_{\text{subcool}} = T_{\text{sat}} - T_3 = 52.40 - 48.58 = \mathbf{3.82^\circ\text{C}}$$

(b) The rate of heat absorbed from the geothermal water in the evaporator is

$$\dot{Q}_L = \dot{m}_w (h_{w1} - h_{w2}) = (0.065 \text{ kg/s})(209.34 - 167.53) \text{ kJ/kg} = 2.718 \text{ kW}$$

This heat is absorbed by the refrigerant in the evaporator

$$\dot{m}_R = \frac{\dot{Q}_L}{h_1 - h_4} = \frac{2.718 \text{ kW}}{(261.64 - 121.25) \text{ kJ/kg}} = \mathbf{0.01936 \text{ kg/s}}$$

(c) The power input to the compressor, the heating load and the COP are

$$\dot{W}_{\text{in}} = \dot{m}_R (h_2 - h_1) + \dot{Q}_{\text{out}} = (0.01936 \text{ kg/s})(280.05 - 261.64) \text{ kJ/kg} = 0.6563 \text{ kW}$$

$$\dot{Q}_H = \dot{m}_R (h_2 - h_3) = (0.01936 \text{ kg/s})(280.05 - 121.25) \text{ kJ/kg} = \mathbf{3.074 \text{ kW}}$$

$$\text{COP} = \frac{\dot{Q}_H}{\dot{W}_{\text{in}}} = \frac{3.074 \text{ kW}}{0.6563 \text{ kW}} = \mathbf{4.68}$$

(d) The reversible COP of the cycle is

$$\text{COP}_{\text{rev}} = \frac{1}{1 - T_L / T_H} = \frac{1}{1 - (25 + 273) / (50 + 273)} = 12.92$$

The corresponding minimum power input is

$$\dot{W}_{\text{in, min}} = \frac{\dot{Q}_H}{\text{COP}_{\text{rev}}} = \frac{3.074 \text{ kW}}{12.92} = \mathbf{0.238 \text{ kW}}$$

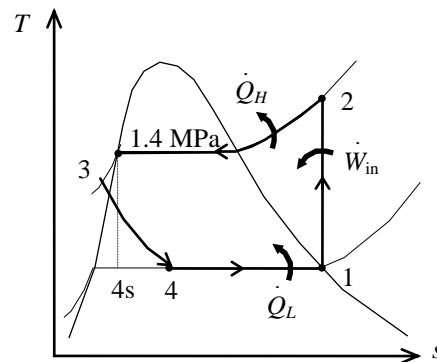
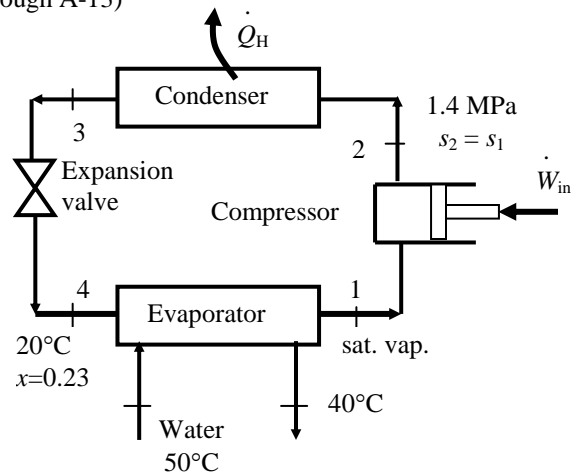

11-44 An actual heat pump cycle with R-134a as the refrigerant is considered. The isentropic efficiency of the compressor, the rate of heat supplied to the heated room, the COP of the heat pump, and the COP and the rate of heat supplied to the heated room if this heat pump operated on the ideal vapor-compression cycle between the same pressure limits are to be determined.

Assumptions 1 Steady operating conditions exist. 2 Kinetic and potential energy changes are negligible.

Analysis (a) The properties of refrigerant-134a are (Tables A-11 through A-13)

$$\left. \begin{aligned} P_2 &= 800 \text{ kPa} \\ T_2 &= 50^\circ\text{C} \end{aligned} \right\} h_2 = 286.71 \text{ kJ/kg}$$

$$T_3 = T_{\text{sat}@750\text{kPa}} = 29.06^\circ\text{C}$$

$$\left. \begin{aligned} P_3 &= 750 \text{ kPa} \\ T_3 &= (29.06 - 3)^\circ\text{C} \end{aligned} \right\} h_3 = 87.93 \text{ kJ/kg}$$

$$h_4 = h_3 = 87.93 \text{ kJ/kg}$$

$$T_{\text{sat}@200\text{kPa}} = -10.09^\circ\text{C}$$

$$\left. \begin{aligned} P_1 &= 200 \text{ kPa} \\ T_1 &= (-10.09 + 4)^\circ\text{C} \end{aligned} \right\} h_1 = 247.88 \text{ kJ/kg}$$

$$s_1 = 0.9507 \text{ kJ/kg}\cdot\text{K}$$

$$\left. \begin{aligned} P_2 &= 800 \text{ kPa} \\ s_2 &= s_1 \end{aligned} \right\} h_{2s} = 277.28$$

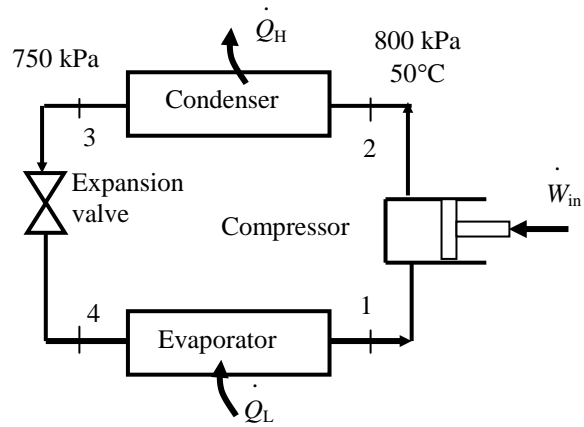

The isentropic efficiency of the compressor is

$$\eta_C = \frac{h_{2s} - h_1}{h_2 - h_1} = \frac{277.28 - 247.88}{286.71 - 247.88} = \mathbf{0.757}$$

(b) The rate of heat supplied to the room is

$$\dot{Q}_H = \dot{m}(h_2 - h_3) = (0.022 \text{ kg/s})(286.71 - 87.93) \text{ kJ/kg} = \mathbf{4.373 \text{ kW}}$$

(c) The power input and the COP are

$$\dot{W}_{\text{in}} = \dot{m}(h_2 - h_1) = (0.022 \text{ kg/s})(286.71 - 247.88) \text{ kJ/kg} = 0.8542 \text{ kW}$$

$$\text{COP} = \frac{\dot{Q}_H}{\dot{W}_{\text{in}}} = \frac{4.373}{0.8542} = \mathbf{5.12}$$

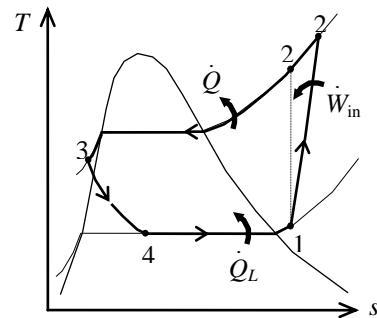

(d) The ideal vapor-compression cycle analysis of the cycle is as follows:

$$h_1 = h_g@200\text{kPa} = 244.50 \text{ kJ/kg}$$

$$s_1 = s_g@200\text{kPa} = 0.9379 \text{ kJ/kg}\cdot\text{K}$$

$$\left. \begin{aligned} P_2 &= 800 \text{ kPa} \\ s_2 &= s_1 \end{aligned} \right\} h_2 = 273.29 \text{ kJ/kg}$$

$$h_3 = h_f@800\text{kPa} = 95.48 \text{ kJ/kg}$$

$$h_4 = h_3$$

$$\text{COP} = \frac{h_2 - h_3}{h_2 - h_1} = \frac{273.29 - 95.48}{273.29 - 244.50} = \mathbf{6.18}$$

$$\dot{Q}_H = \dot{m}(h_2 - h_3) = (0.022 \text{ kg/s})(273.29 - 95.48) \text{ kJ/kg} = \mathbf{3.91 \text{ kW}}$$

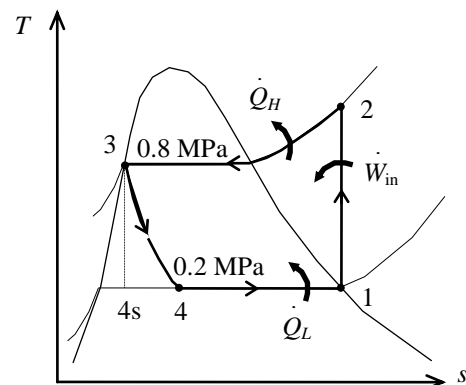

11-45E A heat pump that operates on the ideal vapor-compression cycle with refrigerant-134a is considered. The power input to the heat pump and the electric power saved by using a heat pump instead of a resistance heater are to be determined.

Assumptions 1 Steady operating conditions exist. 2 Kinetic and potential energy changes are negligible.

Analysis In an ideal vapor-compression refrigeration cycle, the compression process is isentropic, the refrigerant enters the compressor as a saturated vapor at the evaporator pressure, and leaves the condenser as saturated liquid at the condenser pressure. From the refrigerant tables (Tables A-12E and A-13E),

$$P_1 = 50 \text{ psia} \left\{ \begin{array}{l} h_1 = h_g @ 50 \text{ psia} = 108.83 \text{ Btu/lbm} \\ \text{sat. vapor} \quad \left. \begin{array}{l} s_1 = s_g @ 50 \text{ psia} = 0.22192 \text{ Btu/lbm} \cdot \text{R} \end{array} \right\} \end{array} \right.$$

$$P_2 = 120 \text{ psia} \left\{ \begin{array}{l} h_2 = 116.64 \text{ Btu/lbm} \\ s_2 = s_1 \end{array} \right.$$

$$P_3 = 120 \text{ psia} \left\{ \begin{array}{l} h_3 = h_f @ 120 \text{ psia} = 41.79 \text{ Btu/lbm} \\ \text{sat. liquid} \end{array} \right.$$

$$h_4 \cong h_3 = 41.79 \text{ Btu/lbm (throttling)}$$

The mass flow rate of the refrigerant and the power input to the compressor are determined from

$$\dot{m} = \frac{\dot{Q}_H}{q_H} = \frac{\dot{Q}_H}{h_2 - h_3} = \frac{60,000/3600 \text{ Btu/s}}{(116.64 - 41.79) \text{ Btu/lbm}} = 0.2227 \text{ lbm/s}$$

and

$$\begin{aligned} \dot{W}_{\text{in}} &= \dot{m}(h_2 - h_1) = (0.2227 \text{ kg/s})(116.64 - 108.83) \text{ Btu/lbm} \\ &= 1.739 \text{ Btu/s} = \mathbf{2.46 \text{ hp}} \text{ since } 1 \text{ hp} = 0.7068 \text{ Btu/s} \end{aligned}$$

The electrical power required without the heat pump is

$$\dot{W}_e = \dot{Q}_H = (60,000/3600 \text{ Btu/s}) \left(\frac{1 \text{ hp}}{0.7068 \text{ Btu/s}} \right) = 23.58 \text{ hp}$$

Thus,

$$\begin{aligned} \dot{W}_{\text{saved}} &= \dot{W}_e - \dot{W}_{\text{in}} = 23.58 - 2.46 \\ &= \mathbf{21.1 \text{ hp}} = 15.75 \text{ kW} \text{ since } 1 \text{ hp} = 0.7457 \text{ kW} \end{aligned}$$

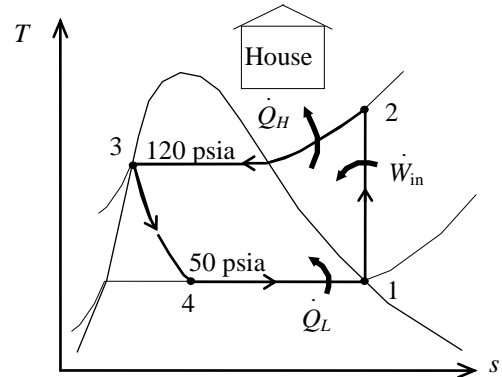

11-46 A heat pump with refrigerant-134a as the working fluid heats a house by using underground water as the heat source. The power input to the heat pump, the rate of heat absorption from the water, and the increase in electric power input if an electric resistance heater is used instead of a heat pump are to be determined.

Assumptions 1 Steady operating conditions exist. 2 Kinetic and potential energy changes are negligible.

Analysis (a) From the refrigerant tables (Tables A-12 and A-13),

$$\left. \begin{array}{l} P_1 = 280 \text{ kPa} \\ T_1 = 0^\circ\text{C} \end{array} \right\} h_1 = 250.85 \text{ kJ/kg}$$

$$\left. \begin{array}{l} P_2 = 1.0 \text{ MPa} \\ T_2 = 60^\circ\text{C} \end{array} \right\} h_2 = 293.40 \text{ kJ/kg}$$

$$\left. \begin{array}{l} P_3 = 1.0 \text{ MPa} \\ T_3 = 30^\circ\text{C} \end{array} \right\} h_3 \cong h_f @ 30^\circ\text{C} = 93.58 \text{ kJ/kg}$$

$$h_4 \cong h_3 = 93.58 \text{ kJ/kg (throttling)}$$

The mass flow rate of the refrigerant is

$$\dot{m}_R = \frac{\dot{Q}_H}{q_H} = \frac{\dot{Q}_H}{h_2 - h_3} = \frac{60,000/3,600 \text{ kJ/s}}{(293.40 - 93.58) \text{ kJ/kg}} = 0.08341 \text{ kg/s}$$

Then the power input to the compressor becomes

$$\dot{W}_{\text{in}} = \dot{m}(h_2 - h_1) = (0.08341 \text{ kg/s})(293.40 - 250.85) \text{ kJ/kg} = \mathbf{3.55 \text{ kW}}$$

(b) The rate of heat absorption from the water is

$$\dot{Q}_L = \dot{m}(h_1 - h_4) = (0.08341 \text{ kg/s})(250.85 - 93.58) \text{ kJ/kg} = \mathbf{13.12 \text{ kW}}$$

(c) The electrical power required without the heat pump is

$$\dot{W}_e = \dot{Q}_H = 60,000/3600 \text{ kJ/s} = 16.67 \text{ kW}$$

Thus,

$$\dot{W}_{\text{increase}} = \dot{W}_e - \dot{W}_{\text{in}} = 16.67 - 3.55 = \mathbf{13.12 \text{ kW}}$$

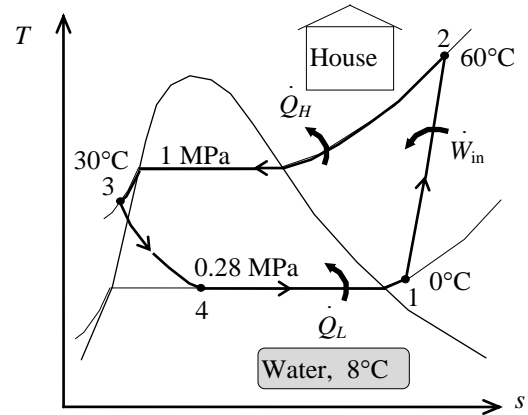



11-47 Problem 11-46 is reconsidered. The effect of the compressor isentropic efficiency on the power input to the compressor and the electric power saved by using a heat pump rather than electric resistance heating is to be investigated.

Analysis The problem is solved using EES, and the solution is given below.

"Input Data"

"Input Data is supplied in the diagram window"

"P[1]=280 [kPa]"

T[1] = 0 [C]"

P[2] = 1000 [kPa]"

T[3] = 30 [C]"

Q_dot_out = 60000 [kJ/h]"

Eta_c=1.0"

Fluid\$='R134a'"

"Use ETA_c = 0.623 to obtain T[2] = 60C"

"Compressor"

h[1]=enthalpy(Fluid\$,P=P[1],T=T[1]) "properties for state 1"

s[1]=entropy(Fluid\$,P=P[1],T=T[1])"

h2s=enthalpy(Fluid\$,P=P[2],s=s[1]) "Identifies state 2s as isentropic"

h[1]+Wcs=h2s "energy balance on isentropic compressor"

Wc=Wcs/Eta_c "definition of compressor isentropic efficiency"

h[1]+Wc=h[2] "energy balance on real compressor-assumed adiabatic"

s[2]=entropy(Fluid\$,h=h[2],P=P[2]) "properties for state 2"

{h[2]=enthalpy(Fluid\$,P=P[2],T=T[2]) }

T[2]=temperature(Fluid\$,h=h[2],P=P[2])"

W_dot_c=m_dot*Wc"

"Condenser"

P[3] = P[2]"

h[3]=enthalpy(Fluid\$,P=P[3],T=T[3]) "properties for state 3"

s[3]=entropy(Fluid\$,P=P[3],T=T[3])"

h[2]=Qout+h[3] "energy balance on condenser"

Q_dot_out*convert(kJ/h,kJ/s)=m_dot*Qout"

"Throttle Valve"

h[4]=h[3] "energy balance on throttle - isenthalpic"

x[4]=quality(Fluid\$,h=h[4],P=P[4]) "properties for state 4"

s[4]=entropy(Fluid\$,h=h[4],P=P[4])"

T[4]=temperature(Fluid\$,h=h[4],P=P[4])"

"Evaporator"

P[4]= P[1]"

Q_in + h[4]=h[1] "energy balance on evaporator"

Q_dot_in=m_dot*Q_in"

COP=Q_dot_out*convert(kJ/h,kJ/s)/W_dot_c "definition of COP"

COP_plot = COP"

W_dot_in = W_dot_c"

E_dot_saved = Q_dot_out*convert(kJ/h,kJ/s) - W_dot_c"[kW]"

W_{in} [kW]	η_c	E_{saved}
3.671	0.6	13
3.249	0.7	13.42
2.914	0.8	13.75
2.641	0.9	14.03
2.415	1	14.25

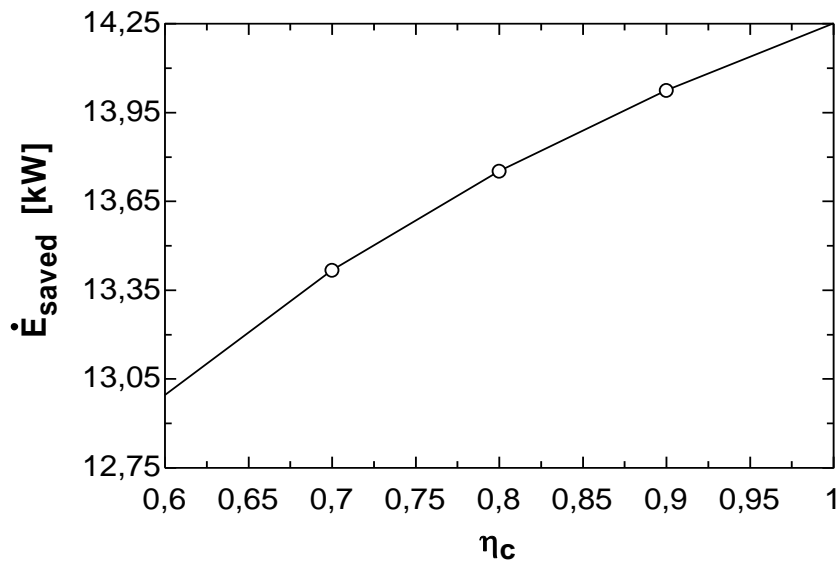
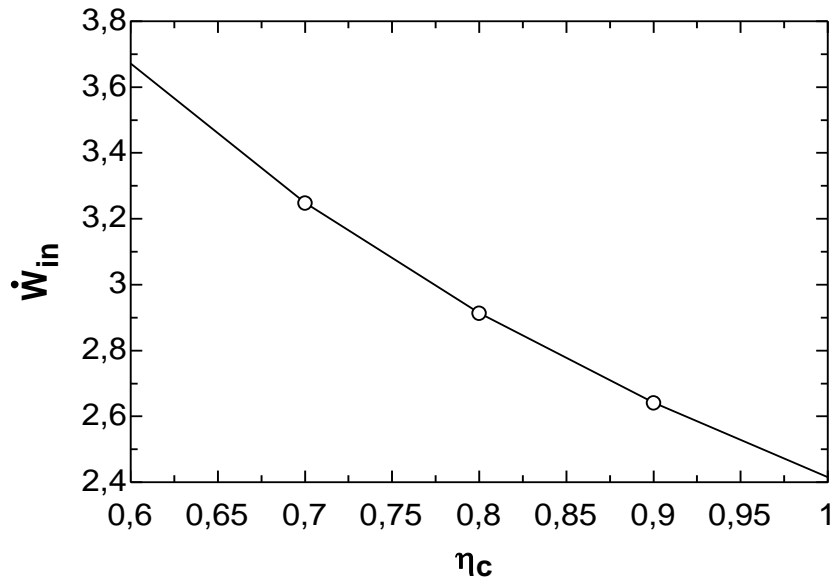

Innovative Refrigeration Systems

11-48C Cascade refrigeration systems have higher COPs than the ordinary refrigeration systems operating between the same pressure limits.

11-49C The saturation pressure of refrigerant-134a at -32°C is 77 kPa, which is below the atmospheric pressure. In reality a pressure below this value should be used. Therefore, a cascade refrigeration system with a different refrigerant at the bottoming cycle is recommended in this case.

11-50C We would favor the two-stage compression refrigeration system with a flash chamber since it is simpler, cheaper, and has better heat transfer characteristics.

11-51C Yes, by expanding the refrigerant in stages in several throttling devices.

11-52C To take advantage of the cooling effect by throttling from high pressures to low pressures.

11-53  A two-stage compression refrigeration system with refrigerant-134a as the working fluid is considered. The fraction of the refrigerant that evaporates as it is throttled to the flash chamber, the rate of heat removed from the refrigerated space, and the COP are to be determined.

Assumptions **1** Steady operating conditions exist. **2** Kinetic and potential energy changes are negligible. **3** The flash chamber is adiabatic.

Analysis (a) The enthalpies of the refrigerant at several states are determined from the refrigerant tables (Tables A-11, A-12, and A-13) to be

$$h_1 = 234.46 \text{ kJ/kg}, \quad h_2 = 262.70 \text{ kJ/kg}$$

$$h_3 = 255.61 \text{ kJ/kg},$$

$$h_5 = 127.25 \text{ kJ/kg}, \quad h_6 = 127.25 \text{ kJ/kg}$$

$$h_7 = 63.92 \text{ kJ/kg}, \quad h_8 = 63.92 \text{ kJ/kg}$$

The fraction of the refrigerant that evaporates as it is throttled to the flash chamber is simply the quality at state 6,

$$x_6 = \frac{h_6 - h_f}{h_{fg}} = \frac{127.25 - 63.92}{191.68} = \mathbf{0.3304}$$

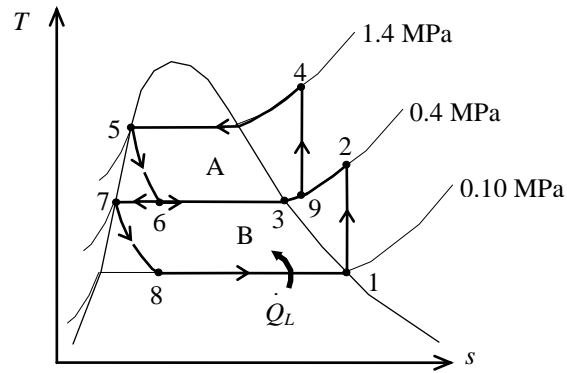

(b) The enthalpy at state 9 is determined from an energy balance on the mixing chamber:

$$\dot{E}_{\text{in}} - \dot{E}_{\text{out}} = \Delta \dot{E}_{\text{system}} \stackrel{\phi^0(\text{steady})}{=} 0$$

$$\dot{E}_{\text{in}} = \dot{E}_{\text{out}}$$

$$\sum \dot{m}_e h_e = \sum \dot{m}_i h_i$$

$$(1)h_9 = x_6 h_3 + (1 - x_6)h_2$$

$$h_9 = (0.3304)(255.61) + (1 - 0.3304)(262.70) = 260.35 \text{ kJ/kg}$$

$$\left. \begin{array}{l} P_9 = 0.4 \text{ MPa} \\ h_9 = 260.35 \text{ kJ/kg} \end{array} \right\} s_9 = 0.9438 \text{ kJ/kg} \cdot \text{K}$$

Also,

$$\left. \begin{array}{l} P_4 = 1.4 \text{ MPa} \\ s_4 = s_9 = 0.9438 \text{ kJ/kg} \cdot \text{K} \end{array} \right\} h_4 = 287.10 \text{ kJ/kg}$$

Then the rate of heat removed from the refrigerated space and the compressor work input per unit mass of refrigerant flowing through the condenser are

$$\dot{m}_B = (1 - x_6)\dot{m}_A = (1 - 0.3304)(0.25 \text{ kg/s}) = 0.1674 \text{ kg/s}$$

$$\dot{Q}_L = \dot{m}_B (h_1 - h_8) = (0.1674 \text{ kg/s})(234.46 - 63.92) \text{ kJ/kg} = \mathbf{28.55 \text{ kW}}$$

$$\begin{aligned} \dot{W}_{\text{in}} &= \dot{W}_{\text{comp I, in}} + \dot{W}_{\text{comp II, in}} = \dot{m}_A (h_4 - h_9) + \dot{m}_B (h_2 - h_1) \\ &= (0.25 \text{ kg/s})(287.10 - 260.35) \text{ kJ/kg} + (0.1674 \text{ kg/s})(262.70 - 234.46) \text{ kJ/kg} \\ &= 11.41 \text{ kW} \end{aligned}$$

(c) The coefficient of performance is determined from

$$\text{COP}_R = \frac{\dot{Q}_L}{\dot{W}_{\text{net, in}}} = \frac{28.55 \text{ kW}}{11.41 \text{ kW}} = \mathbf{2.50}$$

11-54 A two-stage compression refrigeration system with refrigerant-134a as the working fluid is considered. The fraction of the refrigerant that evaporates as it is throttled to the flash chamber, the rate of heat removed from the refrigerated space, and the COP are to be determined.

Assumptions 1 Steady operating conditions exist. 2 Kinetic and potential energy changes are negligible. 3 The flash chamber is adiabatic.

Analysis (a) The enthalpies of the refrigerant at several states are determined from the refrigerant tables (Tables A-11, A-12, and A-13) to be

$$h_1 = 234.46 \text{ kJ/kg}, \quad h_2 = 271.42 \text{ kJ/kg}$$

$$h_3 = 262.46 \text{ kJ/kg},$$

$$h_5 = 127.25 \text{ kJ/kg}, \quad h_6 = 127.25 \text{ kJ/kg}$$

$$h_7 = 81.50 \text{ kJ/kg}, \quad h_8 = 81.50 \text{ kJ/kg}$$

The fraction of the refrigerant that evaporates as it is throttled to the flash chamber is simply the quality at state 6,

$$x_6 = \frac{h_6 - h_f}{h_{fg}} = \frac{127.25 - 81.50}{180.95} = \mathbf{0.2528}$$

(b) The enthalpy at state 9 is determined from an energy balance on the mixing chamber:

$$\dot{E}_{\text{in}} - \dot{E}_{\text{out}} = \Delta \dot{E}_{\text{system}} \overset{\phi^0(\text{steady})}{=} 0$$

$$\dot{E}_{\text{in}} = \dot{E}_{\text{out}}$$

$$\sum \dot{m}_e h_e = \sum \dot{m}_i h_i$$

$$(1)\dot{h}_9 = x_6 \dot{h}_3 + (1 - x_6) \dot{h}_2$$

$$h_9 = (0.2528)(262.46) + (1 - 0.2528)(271.42) = 269.15 \text{ kJ/kg}$$

$$\left. \begin{array}{l} P_9 = 0.6 \text{ MPa} \\ h_9 = 269.15 \text{ kJ/kg} \end{array} \right\} s_9 = 0.9444 \text{ kJ/kg} \cdot \text{K}$$

Also,

$$\left. \begin{array}{l} P_4 = 1.4 \text{ MPa} \\ s_4 = s_9 = 0.9444 \text{ kJ/kg} \cdot \text{K} \end{array} \right\} h_4 = 287.31 \text{ kJ/kg}$$

Then the rate of heat removed from the refrigerated space and the compressor work input per unit mass of refrigerant flowing through the condenser are

$$\dot{m}_B = (1 - x_6) \dot{m}_A = (1 - 0.2528)(0.25 \text{ kg/s}) = 0.1868 \text{ kg/s}$$

$$\dot{Q}_L = \dot{m}_B (h_1 - h_8) = (0.1868 \text{ kg/s})(234.46 - 81.50) \text{ kJ/kg} = \mathbf{28.57 \text{ kW}}$$

$$\begin{aligned} \dot{W}_{\text{in}} &= \dot{W}_{\text{comp I, in}} + \dot{W}_{\text{comp II, in}} = \dot{m}_A (h_4 - h_9) + \dot{m}_B (h_2 - h_1) \\ &= (0.25 \text{ kg/s})(287.31 - 269.15) \text{ kJ/kg} + (0.1868 \text{ kg/s})(271.42 - 234.46) \text{ kJ/kg} \\ &= 11.44 \text{ kW} \end{aligned}$$

(c) The coefficient of performance is determined from

$$\text{COP}_R = \frac{\dot{Q}_L}{\dot{W}_{\text{net, in}}} = \frac{28.57 \text{ kW}}{11.44 \text{ kW}} = \mathbf{2.50}$$

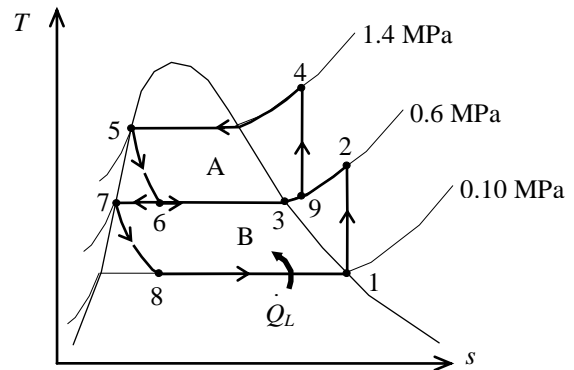



11-55 Problem 11-53 is reconsidered. The effects of the various refrigerants in EES data bank for compressor efficiencies of 80, 90, and 100 percent is to be investigated.

Analysis The problem is solved using EES, and the results are tabulated and plotted below.

Fluid\$='R134a'

"Input Data"

P[1]=100 [kPa]

P[4] = 1400 [kPa]

P[6]=400 [kPa]

"Eta_comp =1.0"

m_dot_A=0.25 [kg/s]

"High Pressure Compressor A"

P[9]=P[6]

h4s=enthalpy(Fluid\$,P=P[4],s=s[9]) "State 4s is the isentropic value of state 4"

h[9]+w_compAs=h4s "energy balance on isentropic compressor"

w_compA=w_compAs/Eta_comp"definition of compressor isentropic efficiency"

h[9]+w_compA=h[4] "energy balance on real compressor-assumed adiabatic"

s[4]=entropy(Fluid\$,h=h[4],P=P[4]) "properties for state 4"

T[4]=temperature(Fluid\$,h=h[4],P=P[4])

W_dot_compA=m_dot_A*w_compA

"Condenser"

P[5]=P[4] "neglect pressure drops across condenser"

T[5]=temperature(Fluid\$,P=P[5],x=0) "properties for state 5, assumes sat. liq. at cond. exit"

h[5]=enthalpy(Fluid\$,T=T[5],x=0) "properties for state 5"

s[5]=entropy(Fluid\$,T=T[5],x=0)

h[4]=q_H+h[5] "energy balance on condenser"

Q_dot_H = m_dot_A*q_H

"Throttle Valve A"

h[6]=h[5] "energy balance on throttle - isenthalpic"

x6=quality(Fluid\$,h=h[6],P=P[6]) "properties for state 6"

s[6]=entropy(Fluid\$,h=h[6],P=P[6])

T[6]=temperature(Fluid\$,h=h[6],P=P[6])

"Flash Chamber"

m_dot_B = (1-x6) * m_dot_A

P[7] = P[6]

h[7]=enthalpy(Fluid\$, P=P[7], x=0)

s[7]=entropy(Fluid\$,h=h[7],P=P[7])

T[7]=temperature(Fluid\$,h=h[7],P=P[7])

"Mixing Chamber"

x6*m_dot_A*h[3] + m_dot_B*h[2] =(x6* m_dot_A + m_dot_B)*h[9]

P[3] = P[6]

h[3]=enthalpy(Fluid\$, P=P[3], x=1) "properties for state 3"

s[3]=entropy(Fluid\$,P=P[3],x=1)

T[3]=temperature(Fluid\$,P=P[3],x=x1)

s[9]=entropy(Fluid\$,h=h[9],P=P[9]) "properties for state 9"

T[9]=temperature(Fluid\$,h=h[9],P=P[9])

"Low Pressure Compressor B"

x1=1 "assume flow to compressor inlet to be saturated vapor"

h[1]=enthalpy(Fluid\$,P=P[1],x=x1) "properties for state 1"

T[1]=temperature(Fluid\$,P=P[1], x=x1)

s[1]=entropy(Fluid\$,P=P[1],x=x1)

$P[2]=P[6]$
 $h_{2s}=\text{enthalpy}(\text{Fluid}\$,P=P[2],s=s[1])$ "state 2s is isentropic state at comp. exit"
 $h[1]+w_{\text{compBs}}=h_{2s}$ "energy balance on isentropic compressor"

$w_{\text{compB}}=w_{\text{compBs}}/\text{Eta}_{\text{comp}}$ "definition of compressor isentropic efficiency"
 $h[1]+w_{\text{compB}}=h[2]$ "energy balance on real compressor-assumed adiabatic"
 $s[2]=\text{entropy}(\text{Fluid}\$,h=h[2],P=P[2])$ "properties for state 2"
 $T[2]=\text{temperature}(\text{Fluid}\$,h=h[2],P=P[2])$
 $W_{\text{dot_compB}}=m_{\text{dot_B}}*w_{\text{compB}}$

"Throttle Valve B"

$h[8]=h[7]$ "energy balance on throttle - isenthalpic"
 $x_8=\text{quality}(\text{Fluid}\$,h=h[8],P=P[8])$ "properties for state 8"
 $s[8]=\text{entropy}(\text{Fluid}\$,h=h[8],P=P[8])$
 $T[8]=\text{temperature}(\text{Fluid}\$,h=h[8],P=P[8])$

"Evaporator"

$P[8]=P[1]$ "neglect pressure drop across evaporator"
 $q_L + h[8]=h[1]$ "energy balance on evaporator"
 $Q_{\text{dot_L}}=m_{\text{dot_B}}*q_L$

"Cycle Statistics"

$W_{\text{dot_in_total}} = W_{\text{dot_compA}} + W_{\text{dot_compB}}$
 $\text{COP} = Q_{\text{dot_L}}/W_{\text{dot_in_total}}$ "definition of COP"

η_{comp}	Q_L [kW]	COP
0.6	28.55	1.438
0.65	28.55	1.57
0.7	28.55	1.702
0.75	28.55	1.835
0.8	28.55	1.968
0.85	28.55	2.101
0.9	28.55	2.235
0.95	28.55	2.368
1	28.55	2.502

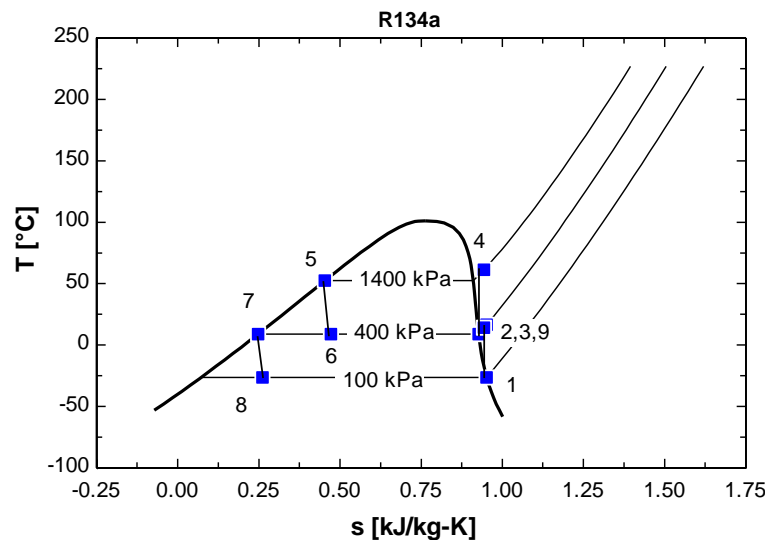

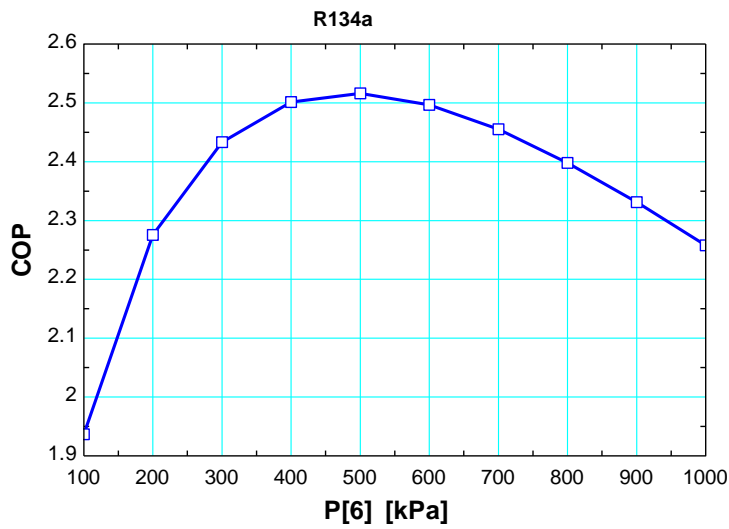
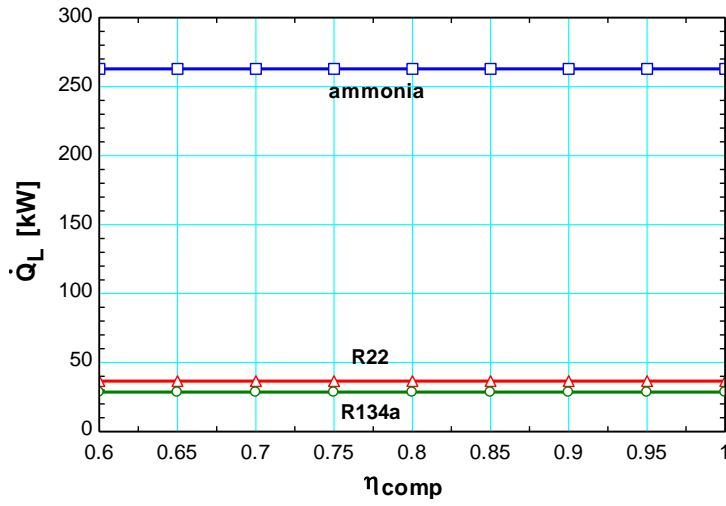
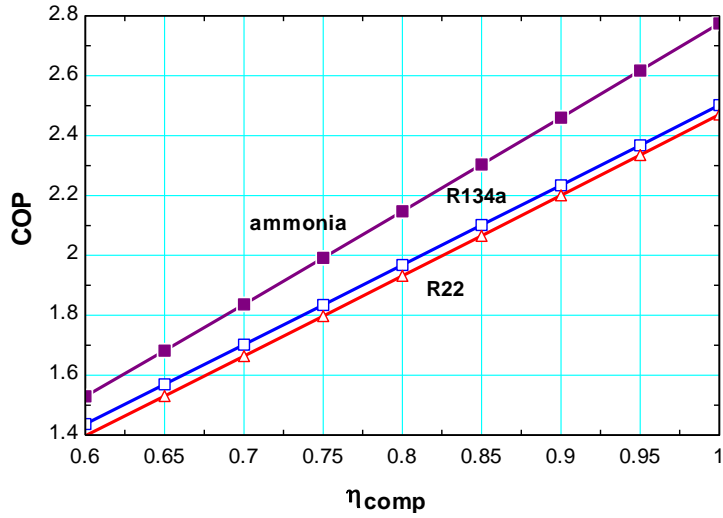

11-56 A two-stage cascade refrigeration system is considered. Each stage operates on the ideal vapor-compression cycle with refrigerant-134a as the working fluid. The mass flow rate of refrigerant through the lower cycle, the rate of heat removal from the refrigerated space, the power input to the compressor, and the COP of this cascade refrigerator are to be determined.

Assumptions 1 Steady operating conditions exist. 2 Kinetic and potential energy changes are negligible. 3 The heat exchanger is adiabatic.

Analysis (a) Each stage of the cascade refrigeration cycle is said to operate on the ideal vapor compression refrigeration cycle. Thus the compression process is isentropic, and the refrigerant enters the compressor as a saturated vapor at the evaporator pressure. Also, the refrigerant leaves the condenser as a saturated liquid at the condenser pressure. The enthalpies of the refrigerant at all 8 states are determined from the refrigerant tables (Tables A-11, A-12, and A-13) to be

$$\begin{aligned} h_1 &= 239.19 \text{ kJ/kg}, & h_2 &= 260.61 \text{ kJ/kg} \\ h_3 &= 63.92 \text{ kJ/kg}, & h_4 &= 63.92 \text{ kJ/kg} \\ h_5 &= 255.61 \text{ kJ/kg}, & h_6 &= 269.96 \text{ kJ/kg} \\ h_7 &= 95.48 \text{ kJ/kg}, & h_8 &= 95.48 \text{ kJ/kg} \end{aligned}$$

The mass flow rate of the refrigerant through the lower cycle is determined from an energy balance on the heat exchanger:

$$\begin{aligned} \dot{E}_{\text{in}} - \dot{E}_{\text{out}} &= \Delta \dot{E}_{\text{system}} \stackrel{\phi^0(\text{steady})}{=} 0 \\ \dot{E}_{\text{in}} &= \dot{E}_{\text{out}} \\ \sum \dot{m}_e h_e &= \sum \dot{m}_i h_i \\ \dot{m}_A (h_5 - h_8) &= \dot{m}_B (h_2 - h_3) \\ \dot{m}_B &= \frac{h_5 - h_8}{h_2 - h_3} \dot{m}_A = \frac{255.61 - 95.48}{260.61 - 63.92} (0.24 \text{ kg/s}) = \mathbf{0.1954 \text{ kg/s}} \end{aligned}$$

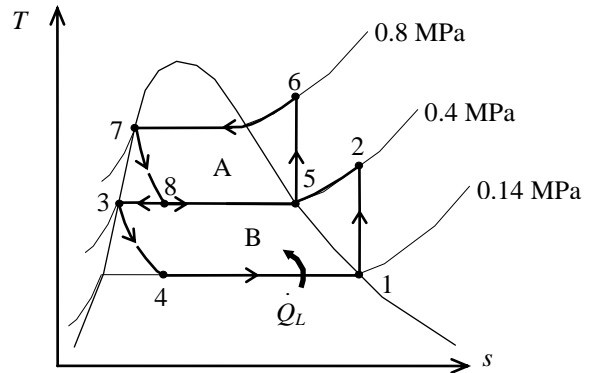

(b) The rate of heat removed by a cascade cycle is the rate of heat absorption in the evaporator of the lowest stage. The power input to a cascade cycle is the sum of the power inputs to all of the compressors:

$$\begin{aligned} \dot{Q}_L &= \dot{m}_B (h_1 - h_4) = (0.1954 \text{ kg/s})(239.19 - 63.92) \text{ kJ/kg} = \mathbf{34.25 \text{ kW}} \\ \dot{W}_{\text{in}} &= \dot{W}_{\text{comp I, in}} + \dot{W}_{\text{comp II, in}} = \dot{m}_A (h_6 - h_5) + \dot{m}_B (h_2 - h_1) \\ &= (0.24 \text{ kg/s})(269.96 - 255.61) \text{ kJ/kg} + (0.1954 \text{ kg/s})(260.61 - 239.19) \text{ kJ/kg} \\ &= \mathbf{7.631 \text{ kW}} \end{aligned}$$

(c) The COP of this refrigeration system is determined from its definition,

$$\text{COP}_R = \frac{\dot{Q}_L}{\dot{W}_{\text{net, in}}} = \frac{34.25 \text{ kW}}{7.631 \text{ kW}} = \mathbf{4.488}$$

11-57 A two-stage cascade refrigeration system is considered. Each stage operates on the ideal vapor-compression cycle with refrigerant-134a as the working fluid. The mass flow rate of refrigerant through the lower cycle, the rate of heat removal from the refrigerated space, the power input to the compressor, and the COP of this cascade refrigerator are to be determined.

Assumptions 1 Steady operating conditions exist. 2 Kinetic and potential energy changes are negligible. 3 The heat exchanger is adiabatic.

Analysis (a) Each stage of the cascade refrigeration cycle is said to operate on the ideal vapor compression refrigeration cycle. Thus the compression process is isentropic, and the refrigerant enters the compressor as a saturated vapor at the evaporator pressure. Also, the refrigerant leaves the condenser as a saturated liquid at the condenser pressure. The enthalpies of the refrigerant at all 8 states are determined from the refrigerant tables (Tables A-11, A-12, and A-13) to be

$$\begin{aligned} h_1 &= 239.19 \text{ kJ/kg}, & h_2 &= 267.37 \text{ kJ/kg} \\ h_3 &= 77.54 \text{ kJ/kg}, & h_4 &= 77.54 \text{ kJ/kg} \\ h_5 &= 260.98 \text{ kJ/kg}, & h_6 &= 268.71 \text{ kJ/kg} \\ h_7 &= 95.48 \text{ kJ/kg}, & h_8 &= 95.48 \text{ kJ/kg} \end{aligned}$$

The mass flow rate of the refrigerant through the lower cycle is determined from an energy balance on the heat exchanger:

$$\dot{E}_{\text{in}} - \dot{E}_{\text{out}} = \Delta \dot{E}_{\text{system}} \stackrel{\phi=0(\text{steady})}{=} 0$$

$$\dot{E}_{\text{in}} = \dot{E}_{\text{out}}$$

$$\sum \dot{m}_e h_e = \sum \dot{m}_i h_i$$

$$\dot{m}_A (h_5 - h_8) = \dot{m}_B (h_2 - h_3)$$

$$\dot{m}_B = \frac{h_5 - h_8}{h_2 - h_3} \dot{m}_A = \frac{260.98 - 95.48}{267.37 - 77.54} (0.24 \text{ kg/s}) = \mathbf{0.2092 \text{ kg/s}}$$

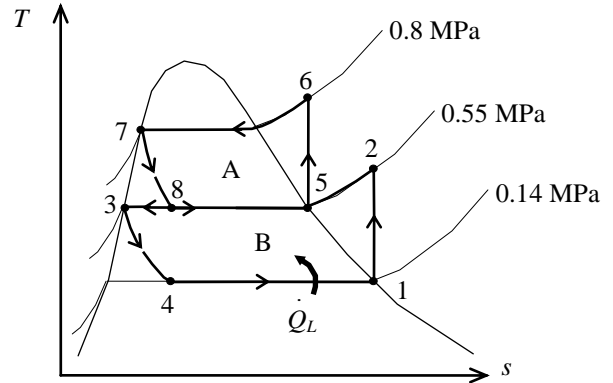

(b) The rate of heat removed by a cascade cycle is the rate of heat absorption in the evaporator of the lowest stage. The power input to a cascade cycle is the sum of the power inputs to all of the compressors:

$$\dot{Q}_L = \dot{m}_B (h_1 - h_4) = (0.2092 \text{ kg/s})(239.19 - 77.54) \text{ kJ/kg} = \mathbf{33.82 \text{ kW}}$$

$$\begin{aligned} \dot{W}_{\text{in}} &= \dot{W}_{\text{compI,in}} + \dot{W}_{\text{compII,in}} = \dot{m}_A (h_6 - h_5) + \dot{m}_B (h_2 - h_1) \\ &= (0.24 \text{ kg/s})(268.71 - 260.98) \text{ kJ/kg} + (0.2092 \text{ kg/s})(267.37 - 239.19) \text{ kJ/kg} \\ &= \mathbf{7.752 \text{ kW}} \end{aligned}$$

(c) The COP of this refrigeration system is determined from its definition,

$$\text{COP}_R = \frac{\dot{Q}_L}{\dot{W}_{\text{net,in}}} = \frac{33.82 \text{ kW}}{7.752 \text{ kW}} = \mathbf{4.363}$$

11-58 A two-stage cascade refrigeration cycle is considered. The mass flow rate of the refrigerant through the upper cycle, the rate of heat removal from the refrigerated space, and the COP of the refrigerator are to be determined.

Assumptions 1 Steady operating conditions exist. 2 Kinetic and potential energy changes are negligible.

Analysis (a) The properties are to be obtained from the refrigerant tables (Tables A-11 through A-13):

$$h_1 = h_{g@160\text{kPa}} = 241.14 \text{ kJ/kg}$$

$$s_1 = s_{g@160\text{kPa}} = 0.9420 \text{ kJ/kg}\cdot\text{K}$$

$$\left. \begin{array}{l} P_2 = 500 \text{ kPa} \\ s_2 = s_1 \end{array} \right\} h_{2s} = 264.55 \text{ kJ/kg}$$

$$\eta_C = \frac{h_{2s} - h_1}{h_2 - h_1}$$

$$0.80 = \frac{264.55 - 241.14}{h_2 - 241.14} \longrightarrow h_2 = 270.41 \text{ kJ/kg}$$

$$h_3 = h_{f@500\text{kPa}} = 73.32 \text{ kJ/kg}$$

$$h_4 = h_3 = 73.32 \text{ kJ/kg}$$

$$h_5 = h_{g@400\text{kPa}} = 255.61 \text{ kJ/kg}$$

$$s_5 = s_{g@400\text{kPa}} = 0.9271 \text{ kJ/kg}\cdot\text{K}$$

$$\left. \begin{array}{l} P_6 = 1400 \text{ kPa} \\ s_6 = s_5 \end{array} \right\} h_{6s} = 281.56 \text{ kJ/kg}$$

$$\eta_C = \frac{h_{6s} - h_5}{h_6 - h_5}$$

$$0.80 = \frac{281.56 - 255.61}{h_6 - 255.61} \longrightarrow h_6 = 288.04 \text{ kJ/kg}$$

$$h_7 = h_{f@1400\text{kPa}} = 127.25 \text{ kJ/kg}$$

$$h_8 = h_7 = 127.25 \text{ kJ/kg}$$

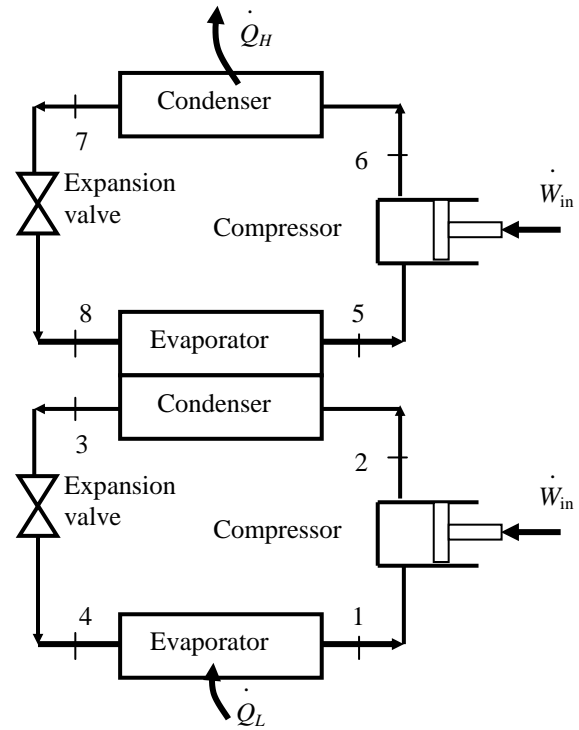

The mass flow rate of the refrigerant through the upper cycle is determined from an energy balance on the heat exchanger

$$\dot{m}_A(h_5 - h_8) = \dot{m}_B(h_2 - h_3)$$

$$\dot{m}_A(255.61 - 127.25) \text{ kJ/kg} = (0.11 \text{ kg/s})(270.41 - 73.32) \text{ kJ/kg} \longrightarrow \dot{m}_A = \mathbf{0.1689 \text{ kg/s}}$$

(b) The rate of heat removal from the refrigerated space is

$$\dot{Q}_L = \dot{m}_B(h_1 - h_4) = (0.11 \text{ kg/s})(241.14 - 73.32) \text{ kJ/kg} = \mathbf{18.46 \text{ kW}}$$

(c) The power input and the COP are

$$\dot{W}_{\text{in}} = \dot{m}_A(h_6 - h_5) + \dot{m}_B(h_2 - h_1)$$

$$= (0.11 \text{ kg/s})(288.04 - 255.61) \text{ kJ/kg} + (0.1689 \text{ kg/s})(270.41 - 241.14) \text{ kJ/kg}$$

$$= 8.698 \text{ kW}$$

$$\text{COP} = \frac{\dot{Q}_L}{\dot{W}_{\text{in}}} = \frac{18.46}{8.698} = \mathbf{2.12}$$

11-59 A two-stage cascade refrigeration cycle with a flash chamber is considered. The mass flow rate of the refrigerant through the high-pressure compressor, the rate of heat removal from the refrigerated space, the COP of the refrigerator, and the rate of heat removal and the COP if this refrigerator operated on a single-stage cycle between the same pressure limits are to be determined.

Assumptions 1 Steady operating conditions exist. 2 Kinetic and potential energy changes are negligible.

Analysis (a) The properties are to be obtained from the refrigerant tables (Tables A-11 through A-13):

$$h_1 = h_{g@200\text{kPa}} = 244.50 \text{ kJ/kg}$$

$$s_1 = s_{g@200\text{kPa}} = 0.9379 \text{ kJ/kg}\cdot\text{K}$$

$$\left. \begin{array}{l} P_2 = 450 \text{ kPa} \\ s_2 = s_1 \end{array} \right\} h_{2s} = 261.13 \text{ kJ/kg}$$

$$\eta_C = \frac{h_{2s} - h_1}{h_2 - h_1}$$

$$0.80 = \frac{261.13 - 244.50}{h_2 - 244.50} \longrightarrow h_2 = 265.28 \text{ kJ/kg}$$

$$h_3 = h_{g@450\text{kPa}} = 257.58 \text{ kJ/kg}$$

$$h_5 = h_{f@1200\text{kPa}} = 117.79 \text{ kJ/kg}$$

$$h_6 = h_5 = 117.79 \text{ kJ/kg}$$

$$h_7 = h_{f@450\text{kPa}} = 68.80 \text{ kJ/kg}$$

$$h_8 = h_7 = 68.810 \text{ kJ/kg}$$

$$\left. \begin{array}{l} h_6 = 117.79 \text{ kJ/kg} \\ P_6 = 450 \text{ kPa} \end{array} \right\} x_6 = 0.2595$$

The mass flow rate of the refrigerant through the high pressure compressor is determined from a mass balance on the flash chamber

$$\dot{m} = \frac{\dot{m}_7}{1 - x_6} = \frac{0.15 \text{ kg/s}}{1 - 0.2595} = \mathbf{0.2026 \text{ kg/s}}$$

Also,

$$\dot{m}_3 = \dot{m} - \dot{m}_7 = 0.2026 - 0.15 = 0.05257 \text{ kg/s}$$

(b) The enthalpy at state 9 is determined from an energy balance on the mixing chamber:

$$\dot{m}h_9 = \dot{m}_7h_2 + \dot{m}_3h_3$$

$$(0.2026 \text{ kg/s})h_9 = (0.15 \text{ kg/s})(265.28 \text{ kJ/kg}) + (0.05257 \text{ kg/s})(257.58 \text{ kJ/kg}) \longrightarrow h_9 = 263.28 \text{ kJ/kg}$$

Then,

$$\left. \begin{array}{l} P_9 = 450 \text{ kPa} \\ h_9 = 263.28 \text{ kJ/kg} \end{array} \right\} s_9 = 0.9453 \text{ kJ/kg}$$

$$\left. \begin{array}{l} P_4 = 1200 \text{ kPa} \\ s_4 = s_9 \end{array} \right\} h_{4s} = 284.32 \text{ kJ/kg}$$

$$\eta_C = \frac{h_{4s} - h_9}{h_4 - h_9}$$

$$0.80 = \frac{284.32 - 263.28}{h_4 - 263.28} \longrightarrow h_4 = 289.57 \text{ kJ/kg}$$

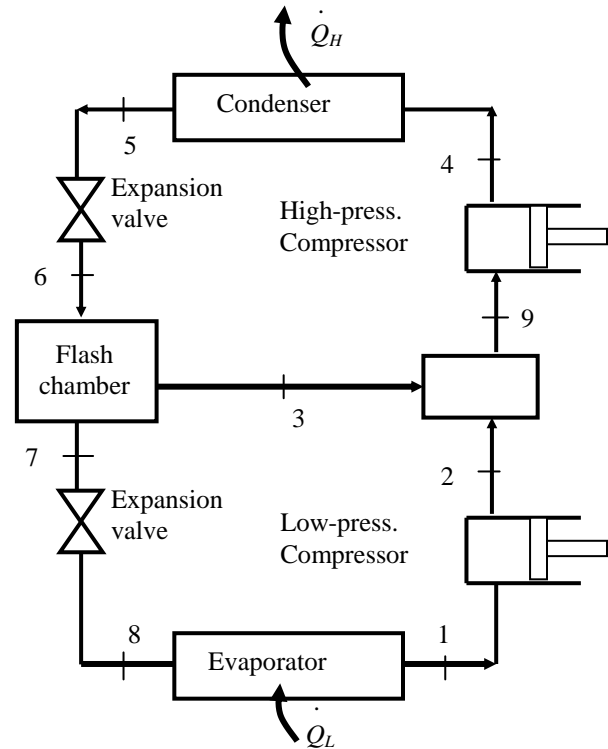

The rate of heat removal from the refrigerated space is

$$\dot{Q}_L = \dot{m}_7(h_1 - h_8) = (0.15 \text{ kg/s})(244.50 - 68.80) \text{ kJ/kg} = \mathbf{26.35 \text{ kW}}$$

(c) The power input and the COP are

$$\begin{aligned} \dot{W}_{\text{in}} &= \dot{m}_7(h_2 - h_1) + \dot{m}(h_4 - h_9) \\ &= (0.15 \text{ kg/s})(265.28 - 244.50) \text{ kJ/kg} + (0.2026 \text{ kg/s})(289.57 - 263.28) \text{ kJ/kg} \\ &= 8.444 \text{ kW} \end{aligned}$$

$$\text{COP} = \frac{\dot{Q}_L}{\dot{W}_{\text{in}}} = \frac{26.35}{8.444} = \mathbf{3.12}$$

(d) If this refrigerator operated on a single-stage cycle between the same pressure limits, we would have

$$h_1 = h_g @ 200 \text{ kPa} = 244.50 \text{ kJ/kg}$$

$$s_1 = s_g @ 200 \text{ kPa} = 0.9379 \text{ kJ/kg}\cdot\text{K}$$

$$\left. \begin{array}{l} P_2 = 1200 \text{ kPa} \\ s_2 = s_1 \end{array} \right\} h_{2s} = 281.88 \text{ kJ/kg}$$

$$\eta_C = \frac{h_{2s} - h_1}{h_2 - h_1}$$

$$0.80 = \frac{281.88 - 244.50}{h_2 - 244.50} \longrightarrow h_2 = 291.23 \text{ kJ/kg}$$

$$h_3 = h_f @ 1200 \text{ kPa} = 117.79 \text{ kJ/kg}$$

$$h_4 = h_3 = 117.79 \text{ kJ/kg}$$

$$\dot{Q}_L = \dot{m}(h_1 - h_4) = (0.2026 \text{ kg/s})(244.50 - 117.79) \text{ kJ/kg} = \mathbf{25.67 \text{ kW}}$$

$$\dot{W}_{\text{in}} = \dot{m}(h_2 - h_1) = (0.2026 \text{ kg/s})(291.23 - 244.50) \text{ kJ/kg} = 9.467 \text{ kW}$$

$$\text{COP} = \frac{\dot{Q}_L}{\dot{W}_{\text{in}}} = \frac{25.67}{9.467} = \mathbf{2.71}$$

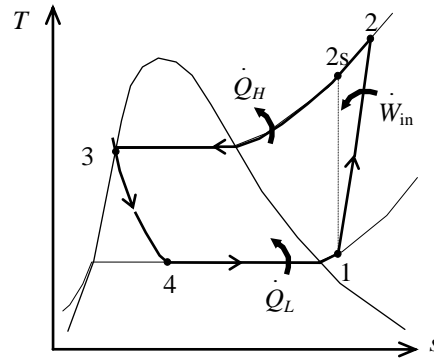

11-60 A two-evaporator compression refrigeration cycle with refrigerant-134a as the working fluid is considered. The cooling rate of the high-temperature evaporator, the power required by the compressor, and the COP of the system are to be determined.

Assumptions 1 Steady operating conditions exist. 2 Kinetic and potential energy changes are negligible.

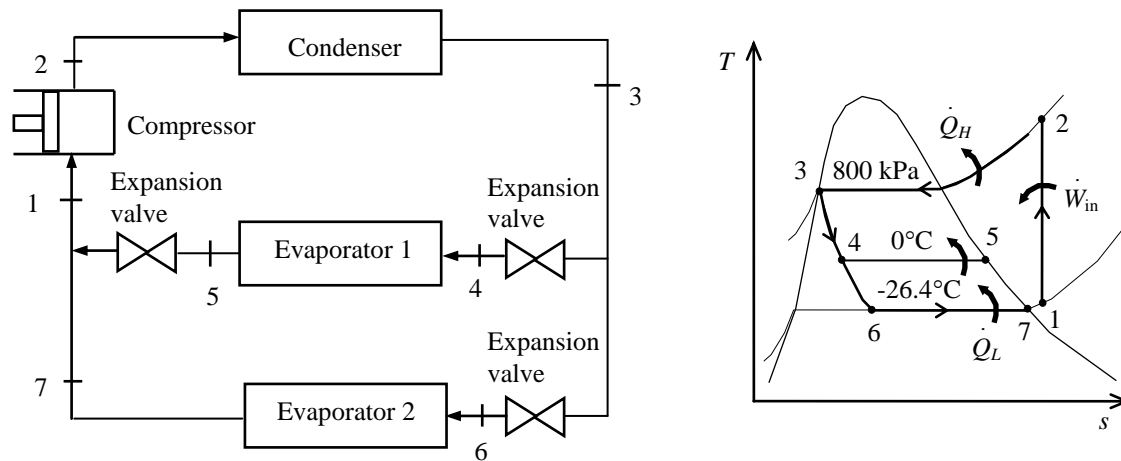

Analysis From the refrigerant tables (Tables A-11, A-12, and A-13),

$$\left. \begin{array}{l} P_3 = 800 \text{ kPa} \\ \text{sat. liquid} \end{array} \right\} h_3 = h_f @ 800 \text{ kPa} = 95.48 \text{ kJ/kg}$$

$$h_4 = h_6 \cong h_3 = 95.48 \text{ kJ/kg} \quad (\text{throttling})$$

$$\left. \begin{array}{l} T_5 = 0^\circ\text{C} \\ \text{sat. vapor} \end{array} \right\} h_5 = h_g @ 0^\circ\text{C} = 250.50 \text{ kJ/kg}$$

$$\left. \begin{array}{l} T_7 = -26.4^\circ\text{C} \\ \text{sat. vapor} \end{array} \right\} h_7 = h_g @ -26.4^\circ\text{C} = 234.44 \text{ kJ/kg}$$

The mass flow rate through the low-temperature evaporator is found by

$$\dot{Q}_L = \dot{m}_2(h_7 - h_6) \longrightarrow \dot{m}_2 = \frac{\dot{Q}_L}{h_7 - h_6} = \frac{8 \text{ kJ/s}}{(234.44 - 95.48) \text{ kJ/kg}} = 0.05757 \text{ kg/s}$$

The mass flow rate through the warmer evaporator is then

$$\dot{m}_1 = \dot{m} - \dot{m}_2 = 0.1 - 0.05757 = 0.04243 \text{ kg/s}$$

Applying an energy balance to the point in the system where the two evaporator streams are recombined gives

$$\dot{m}_1 h_5 + \dot{m}_2 h_7 = \dot{m} h_1 \longrightarrow h_1 = \frac{\dot{m}_1 h_5 + \dot{m}_2 h_7}{\dot{m}} = \frac{(0.04243)(250.50) + (0.05757)(234.44)}{0.1} = 241.26 \text{ kJ/kg}$$

Then,

$$\left. \begin{array}{l} P_1 = P_{\text{sat}} @ -26.4^\circ\text{C} \cong 100 \text{ kPa} \\ h_1 = 241.26 \text{ kJ/kg} \end{array} \right\} s_1 = 0.9791 \text{ kJ/kg} \cdot \text{K}$$

$$\left. \begin{array}{l} P_2 = 800 \text{ kPa} \\ s_2 = s_1 \end{array} \right\} h_2 = 286.32 \text{ kJ/kg}$$

The cooling rate of the high-temperature evaporator is

$$\dot{Q}_L = \dot{m}_1(h_5 - h_4) = (0.04243 \text{ kg/s})(250.50 - 95.48) \text{ kJ/kg} = \mathbf{6.578 \text{ kW}}$$

The power input to the compressor is

$$\dot{W}_{\text{in}} = \dot{m}(h_2 - h_1) = (0.1 \text{ kg/s})(286.32 - 241.26) \text{ kJ/kg} = \mathbf{4.506 \text{ kW}}$$

The COP of this refrigeration system is determined from its definition,

$$\text{COP}_R = \frac{\dot{Q}_L}{\dot{W}_{\text{in}}} = \frac{(8 + 6.578) \text{ kW}}{4.506 \text{ kW}} = \mathbf{3.24}$$

11-61E A two-evaporator compression refrigeration cycle with refrigerant-134a as the working fluid is considered. The power required by the compressor and the COP of the system are to be determined.

Assumptions 1 Steady operating conditions exist. 2 Kinetic and potential energy changes are negligible.

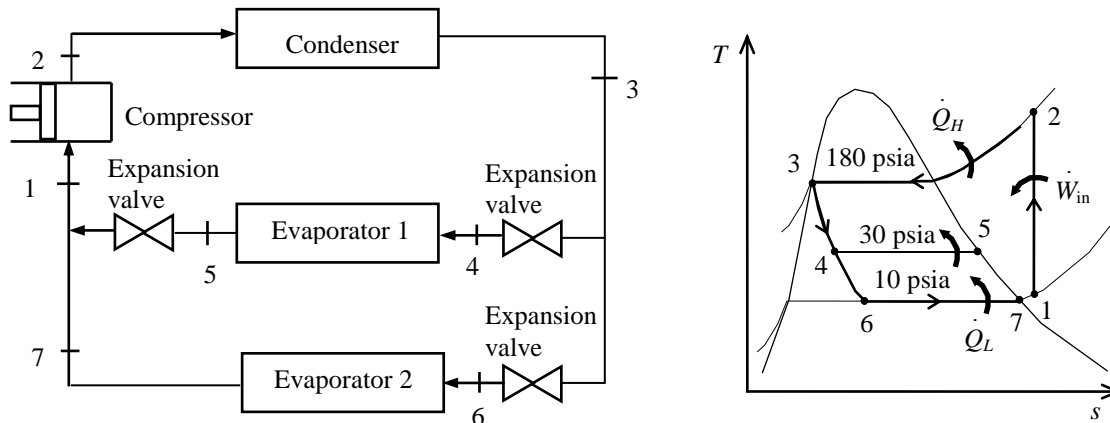

Analysis From the refrigerant tables (Tables A-11E, A-12E, and A-13E),

$$\left. \begin{array}{l} P_3 = 180 \text{ psia} \\ \text{sat. liquid} \end{array} \right\} h_3 = h_f @ 180 \text{ psia} = 51.51 \text{ Btu/lbm}$$

$$h_4 = h_6 \cong h_3 = 51.51 \text{ Btu/lbm} \quad (\text{throttling})$$

$$\left. \begin{array}{l} P_5 = 30 \text{ psia} \\ \text{sat. vapor} \end{array} \right\} h_5 = h_g @ 30 \text{ psia} = 105.34 \text{ Btu/lbm}$$

$$\left. \begin{array}{l} P_7 = 10 \text{ psia} \\ \text{sat. vapor} \end{array} \right\} h_7 = h_g @ 10 \text{ psia} = 98.69 \text{ Btu/lbm}$$

The mass flow rates through the high-temperature and low-temperature evaporators are found by

$$\dot{Q}_{L,1} = \dot{m}_1 (h_5 - h_4) \longrightarrow \dot{m}_1 = \frac{\dot{Q}_{L,1}}{h_5 - h_4} = \frac{9000 \text{ Btu/h}}{(105.34 - 51.51) \text{ Btu/lbm}} = 167.2 \text{ lbm/h}$$

$$\dot{Q}_{L,2} = \dot{m}_2 (h_7 - h_6) \longrightarrow \dot{m}_2 = \frac{\dot{Q}_{L,2}}{h_7 - h_6} = \frac{24,000 \text{ Btu/h}}{(98.69 - 51.51) \text{ Btu/lbm}} = 508.7 \text{ lbm/h}$$

Applying an energy balance to the point in the system where the two evaporator streams are recombined gives

$$\dot{m}_1 h_5 + \dot{m}_2 h_7 = (\dot{m}_1 + \dot{m}_2) h_1 \longrightarrow h_1 = \frac{\dot{m}_1 h_5 + \dot{m}_2 h_7}{\dot{m}_1 + \dot{m}_2} = \frac{(167.2)(105.34) + (508.7)(98.69)}{167.2 + 508.7} = 100.33 \text{ Btu/lbm}$$

Then,

$$\left. \begin{array}{l} P_1 = 10 \text{ psia} \\ h_1 = 100.33 \text{ Btu/lbm} \end{array} \right\} s_1 = 0.2333 \text{ Btu/lbm} \cdot \text{R}$$

$$\left. \begin{array}{l} P_2 = 180 \text{ psia} \\ s_2 = s_1 \end{array} \right\} h_2 = 127.06 \text{ Btu/lbm}$$

The power input to the compressor is

$$\dot{W}_{\text{in}} = (\dot{m}_1 + \dot{m}_2)(h_2 - h_1) = (167.2 + 508.7) \text{ lbm/h}(127.06 - 100.33) \text{ Btu/lbm} \left(\frac{1 \text{ kW}}{3412.14 \text{ Btu/h}} \right) = \mathbf{5.293 \text{ kW}}$$

The COP of this refrigeration system is determined from its definition,

$$\text{COP}_R = \frac{\dot{Q}_L}{\dot{W}_{\text{in}}} = \frac{(24,000 + 9000) \text{ Btu/h}}{5.293 \text{ kW}} \left(\frac{1 \text{ kW}}{3412.14 \text{ Btu/h}} \right) = \mathbf{1.83}$$

11-62E A two-evaporator compression refrigeration cycle with refrigerant-134a as the working fluid is considered. The power required by the compressor and the COP of the system are to be determined.

Assumptions 1 Steady operating conditions exist. 2 Kinetic and potential energy changes are negligible.

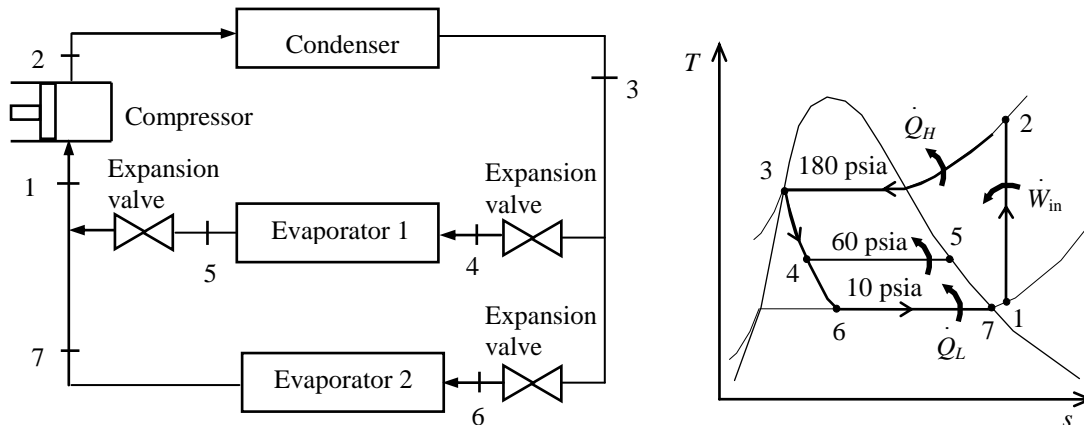

Analysis From the refrigerant tables (Tables A-11E, A-12E, and A-13E),

$$\left. \begin{array}{l} P_3 = 180 \text{ psia} \\ \text{sat. liquid} \end{array} \right\} h_3 = h_f @ 180 \text{ psia} = 51.51 \text{ Btu/lbm}$$

$$h_4 = h_6 \cong h_3 = 51.51 \text{ Btu/lbm} \quad (\text{throttling})$$

$$\left. \begin{array}{l} P_5 = 60 \text{ psia} \\ \text{sat. vapor} \end{array} \right\} h_5 = h_g @ 60 \text{ psia} = 110.13 \text{ Btu/lbm}$$

$$\left. \begin{array}{l} P_7 = 10 \text{ psia} \\ \text{sat. vapor} \end{array} \right\} h_7 = h_g @ 10 \text{ psia} = 98.69 \text{ Btu/lbm}$$

The mass flow rates through the high-temperature and low-temperature evaporators are found by

$$\dot{Q}_{L,1} = \dot{m}_1 (h_5 - h_4) \longrightarrow \dot{m}_1 = \frac{\dot{Q}_{L,1}}{h_5 - h_4} = \frac{15,000 \text{ Btu/h}}{(110.13 - 51.51) \text{ Btu/lbm}} = 255.9 \text{ lbm/h}$$

$$\dot{Q}_{L,2} = \dot{m}_2 (h_7 - h_6) \longrightarrow \dot{m}_2 = \frac{\dot{Q}_{L,2}}{h_7 - h_6} = \frac{24,000 \text{ Btu/h}}{(98.69 - 51.51) \text{ Btu/lbm}} = 508.7 \text{ lbm/h}$$

Applying an energy balance to the point in the system where the two evaporator streams are recombined gives

$$\dot{m}_1 h_5 + \dot{m}_2 h_7 = (\dot{m}_1 + \dot{m}_2) h_1 \longrightarrow h_1 = \frac{\dot{m}_1 h_5 + \dot{m}_2 h_7}{\dot{m}_1 + \dot{m}_2} = \frac{(255.9)(110.13) + (508.7)(98.69)}{255.9 + 508.7} = 102.52 \text{ Btu/lbm}$$

Then,

$$\left. \begin{array}{l} P_1 = 10 \text{ psia} \\ h_1 = 102.52 \text{ Btu/lbm} \end{array} \right\} s_1 = 0.2382 \text{ Btu/lbm} \cdot \text{R}$$

$$\left. \begin{array}{l} P_2 = 180 \text{ psia} \\ s_2 = s_1 \end{array} \right\} h_2 = 130.08 \text{ Btu/lbm}$$

The power input to the compressor is

$$\dot{W}_{\text{in}} = (\dot{m}_1 + \dot{m}_2)(h_2 - h_1) = (255.9 + 508.7) \text{ lbm/h}(130.08 - 102.52) \text{ Btu/lbm} \left(\frac{1 \text{ kW}}{3412.14 \text{ Btu/h}} \right) = \mathbf{6.176 \text{ kW}}$$

The COP of this refrigeration system is determined from its definition,

$$\text{COP}_R = \frac{\dot{Q}_L}{\dot{W}_{\text{in}}} = \frac{(24,000 + 15,000) \text{ Btu/h}}{6.176 \text{ kW}} \left(\frac{1 \text{ kW}}{3412.14 \text{ Btu/h}} \right) = \mathbf{1.85}$$

Gas Refrigeration Cycles

11-63C In the ideal gas refrigeration cycle, the heat absorption and the heat rejection processes occur at constant pressure instead of at constant temperature.

11-64C The reversed Stirling cycle is identical to the Stirling cycle, except it operates in the reversed direction. Remembering that the Stirling cycle is a totally reversible cycle, the reversed Stirling cycle is also totally reversible, and thus its COP is

$$\text{COP}_{\text{R,Stirling}} = \frac{1}{T_H/T_L - 1}$$

11-65C In aircraft cooling, the atmospheric air is compressed by a compressor, cooled by the surrounding air, and expanded in a turbine. The cool air leaving the turbine is then directly routed to the cabin.

11-66C No; because $h = h(T)$ for ideal gases, and the temperature of air will not drop during a throttling ($h_1 = h_2$) process.

11-67C By regeneration.

11-68E An ideal-gas refrigeration cycle with air as the working fluid is considered. The rate of refrigeration, the net power input, and the COP are to be determined.

Assumptions 1 Steady operating conditions exist. 2 Air is an ideal gas with variable specific heats. 3 Kinetic and potential energy changes are negligible.

Analysis (a) We assume both the turbine and the compressor to be isentropic, the turbine inlet temperature to be the temperature of the surroundings, and the compressor inlet temperature to be the temperature of the refrigerated space. From the air table (Table A-17E),

$$T_1 = 500 \text{ R} \longrightarrow \begin{aligned} h_1 &= 119.48 \text{ Btu/lbm} \\ P_{r_1} &= 1.0590 \end{aligned}$$

$$T_3 = 580 \text{ R} \longrightarrow \begin{aligned} h_3 &= 138.66 \text{ Btu/lbm} \\ P_{r_3} &= 1.7800 \end{aligned}$$

Thus,

$$P_2 = \frac{P_2}{P_1} P_1 = \left(\frac{30}{10}\right)(1.0590) = 3.177 \longrightarrow \begin{aligned} T_2 &= 683.9 \text{ R} \\ h_2 &= 163.68 \text{ Btu/lbm} \end{aligned}$$

$$P_4 = \frac{P_4}{P_3} P_3 = \left(\frac{10}{30}\right)(1.7800) = 0.5933 \longrightarrow \begin{aligned} T_4 &= 423.4 \text{ R} \\ h_4 &= 101.14 \text{ Btu/lbm} \end{aligned}$$

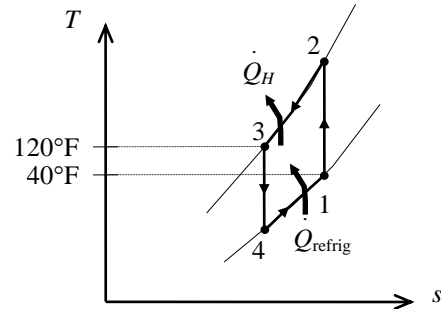

Then the rate of refrigeration is

$$\dot{Q}_{\text{refrig}} = \dot{m}(q_L) = \dot{m}(h_1 - h_4) = (0.5 \text{ lbm/s})(119.48 - 101.14) \text{ Btu/lbm} = \mathbf{9.17 \text{ Btu/s}}$$

(b) The net power input is determined from

$$\dot{W}_{\text{net, in}} = \dot{W}_{\text{comp, in}} - \dot{W}_{\text{turb, out}}$$

where

$$\dot{W}_{\text{comp, in}} = \dot{m}(h_2 - h_1) = (0.5 \text{ lbm/s})(163.68 - 119.48) \text{ Btu/lbm} = 22.10 \text{ Btu/s}$$

$$\dot{W}_{\text{turb, out}} = \dot{m}(h_3 - h_4) = (0.5 \text{ lbm/s})(138.66 - 101.14) \text{ Btu/lbm} = 18.79 \text{ Btu/s}$$

Thus,

$$\dot{W}_{\text{net, in}} = 22.10 - 18.76 = 3.34 \text{ Btu/s} = \mathbf{4.73 \text{ hp}}$$

(c) The COP of this ideal gas refrigeration cycle is determined from

$$\text{COP}_R = \frac{\dot{Q}_L}{\dot{W}_{\text{net, in}}} = \frac{9.17 \text{ Btu/s}}{3.34 \text{ Btu/s}} = \mathbf{2.75}$$

11-69 An ideal-gas refrigeration cycle with air as the working fluid is considered. The maximum and minimum temperatures in the cycle, the COP, and the rate of refrigeration are to be determined.

Assumptions 1 Steady operating conditions exist. 2 Air is an ideal gas with variable specific heats. 3 Kinetic and potential energy changes are negligible.

Analysis (a) We assume both the turbine and the compressor to be isentropic, the turbine inlet temperature to be the temperature of the surroundings, and the compressor inlet temperature to be the temperature of the refrigerated space. From the air table (Table A-17),

$$T_1 = 250 \text{ K} \longrightarrow \begin{aligned} h_1 &= 250.05 \text{ kJ/kg} \\ P_{r_1} &= 0.7329 \end{aligned}$$

$$T_3 = 300 \text{ K} \longrightarrow \begin{aligned} h_3 &= 300.19 \text{ kJ/kg} \\ P_{r_3} &= 1.386 \end{aligned}$$

Thus,

$$P_{r_2} = \frac{P_2}{P_1} P_{r_1} = (3)(0.7329) = 2.1987 \longrightarrow \begin{aligned} T_2 = T_{\max} &= \mathbf{342.2 \text{ K}} \\ h_2 &= 342.60 \text{ kJ/kg} \end{aligned}$$

$$P_{r_4} = \frac{P_4}{P_3} P_{r_3} = \left(\frac{1}{3}\right)(1.386) = 0.462 \longrightarrow \begin{aligned} T_4 = T_{\min} &= \mathbf{219.0 \text{ K}} \\ h_4 &= 218.97 \text{ kJ/kg} \end{aligned}$$

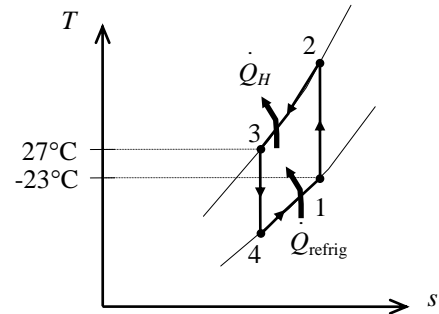

(b) The COP of this ideal gas refrigeration cycle is determined from

$$\text{COP}_R = \frac{q_L}{w_{\text{net, in}}} = \frac{q_L}{w_{\text{comp, in}} - w_{\text{turb, out}}}$$

where

$$\begin{aligned} q_L &= h_1 - h_4 = 250.05 - 218.97 = 31.08 \text{ kJ/kg} \\ w_{\text{comp, in}} &= h_2 - h_1 = 342.60 - 250.05 = 92.55 \text{ kJ/kg} \\ w_{\text{turb, out}} &= h_3 - h_4 = 300.19 - 218.97 = 81.22 \text{ kJ/kg} \end{aligned}$$

Thus,

$$\text{COP}_R = \frac{31.08}{92.55 - 81.22} = \mathbf{2.74}$$

(c) The rate of refrigeration is determined to be

$$\dot{Q}_{\text{refrig}} = \dot{m}(q_L) = (0.08 \text{ kg/s})(31.08 \text{ kJ/kg}) = \mathbf{2.49 \text{ kJ/s}}$$

11-70  An ideal-gas refrigeration cycle with air as the working fluid is considered. The rate of refrigeration, the net power input, and the COP are to be determined.

Assumptions **1** Steady operating conditions exist. **2** Air is an ideal gas with variable specific heats. **3** Kinetic and potential energy changes are negligible.

Analysis (a) We assume both the turbine and the compressor to be isentropic, the turbine inlet temperature to be the temperature of the surroundings, and the compressor inlet temperature to be the temperature of the refrigerated space. From the air table (Table A-17),

$$T_1 = 280 \text{ K} \longrightarrow h_1 = 280.13 \text{ kJ/kg} \\ P_{r_1} = 1.0889$$

$$T_3 = 310 \text{ K} \longrightarrow h_3 = 310.24 \text{ kJ/kg} \\ P_{r_3} = 1.5546$$

Thus,

$$P_{r_2} = \frac{P_2}{P_1} P_{r_1} = \left(\frac{160}{35} \right) (1.0889) = 4.978 \longrightarrow T_2 = 431.5 \text{ K} \\ h_2 = 432.96 \text{ kJ/kg}$$

$$P_{r_4} = \frac{P_4}{P_3} P_{r_3} = \left(\frac{35}{160} \right) (1.5546) = 0.3401 \longrightarrow T_4 = 200.6 \text{ K} \\ h_4 = 200.57 \text{ kJ/kg}$$

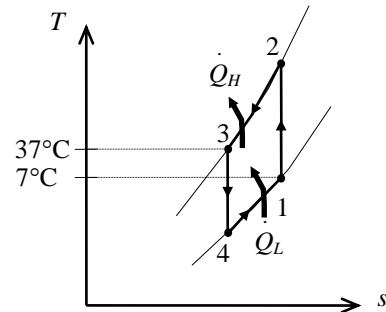

Then the rate of refrigeration is

$$\dot{Q}_L = \dot{m}(q_L) = \dot{m}(h_1 - h_4) = (0.2 \text{ kg/s})(280.13 - 200.57) \text{ kJ/kg} = \mathbf{15.9 \text{ kW}}$$

(b) The net power input is determined from

$$\dot{W}_{\text{net, in}} = \dot{W}_{\text{comp, in}} - \dot{W}_{\text{turb, out}}$$

where

$$\dot{W}_{\text{comp, in}} = \dot{m}(h_2 - h_1) = (0.2 \text{ kg/s})(432.96 - 280.13) \text{ kJ/kg} = 30.57 \text{ kW}$$

$$\dot{W}_{\text{turb, out}} = \dot{m}(h_3 - h_4) = (0.2 \text{ kg/s})(310.24 - 200.57) \text{ kJ/kg} = 21.93 \text{ kW}$$

Thus,

$$\dot{W}_{\text{net, in}} = 30.57 - 21.93 = \mathbf{8.64 \text{ kW}}$$

(c) The COP of this ideal gas refrigeration cycle is determined from

$$\text{COP}_R = \frac{\dot{Q}_L}{\dot{W}_{\text{net, in}}} = \frac{15.9 \text{ kW}}{8.64 \text{ kW}} = \mathbf{1.84}$$

11-71 An ideal-gas refrigeration cycle with air as the working fluid is considered. The rate of refrigeration, the net power input, and the COP are to be determined.

Assumptions 1 Steady operating conditions exist. 2 Air is an ideal gas with variable specific heats. 3 Kinetic and potential energy changes are negligible.

Analysis (a) We assume the turbine inlet temperature to be the temperature of the surroundings, and the compressor inlet temperature to be the temperature of the refrigerated space. From the air table (Table A-17),

$$T_1 = 280 \text{ K} \longrightarrow h_1 = 280.13 \text{ kJ/kg}$$

$$P_{r_1} = 1.0889$$

$$T_3 = 310 \text{ K} \longrightarrow h_3 = 310.24 \text{ kJ/kg}$$

$$P_{r_3} = 1.5546$$

Thus,

$$P_{r_2} = \frac{P_2}{P_1} P_{r_1} = \left(\frac{160}{35} \right) (1.0889) = 4.978 \longrightarrow T_{2s} = 431.5 \text{ K}$$

$$h_{2s} = 432.96 \text{ kJ/kg}$$

$$P_{r_4} = \frac{P_4}{P_3} P_{r_3} = \left(\frac{35}{160} \right) (1.5546) = 0.3401 \longrightarrow T_{4s} = 200.6 \text{ K}$$

$$h_{4s} = 200.57 \text{ kJ/kg}$$

Also,

$$\eta_T = \frac{h_3 - h_4}{h_3 - h_{4s}} \longrightarrow h_4 = h_3 - \eta_T (h_3 - h_{4s})$$

$$= 310.24 - (0.85)(310.24 - 200.57)$$

$$= 217.02 \text{ kJ/kg}$$

Then the rate of refrigeration is

$$\dot{Q}_L = \dot{m}(q_L) = \dot{m}(h_1 - h_4) = (0.2 \text{ kg/s})(280.13 - 217.02) \text{ kJ/kg} = \mathbf{12.6 \text{ kW}}$$

(b) The net power input is determined from

$$\dot{W}_{\text{net,in}} = \dot{W}_{\text{comp,in}} - \dot{W}_{\text{turb,out}}$$

where

$$\dot{W}_{\text{comp,in}} = \dot{m}(h_2 - h_1) = \dot{m}(h_{2s} - h_1) / \eta_C$$

$$= (0.2 \text{ kg/s})[(432.96 - 280.13) \text{ kJ/kg}] / (0.80) = 38.21 \text{ kW}$$

$$\dot{W}_{\text{turb,out}} = \dot{m}(h_3 - h_4) = (0.2 \text{ kg/s})(310.24 - 217.02) \text{ kJ/kg} = 18.64 \text{ kW}$$

Thus,

$$\dot{W}_{\text{net,in}} = 38.21 - 18.64 = \mathbf{19.6 \text{ kW}}$$

(c) The COP of this ideal gas refrigeration cycle is determined from

$$\text{COP}_R = \frac{\dot{Q}_L}{\dot{W}_{\text{net,in}}} = \frac{12.6 \text{ kW}}{19.6 \text{ kW}} = \mathbf{0.643}$$

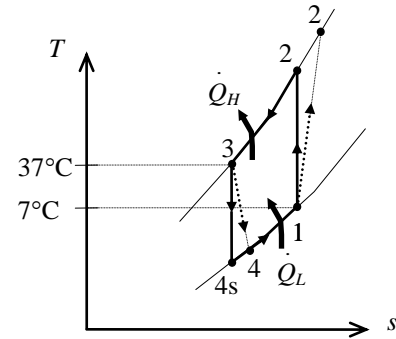



11-72 Problem 11-71 is reconsidered. The effects of compressor and turbine isentropic efficiencies on the rate of refrigeration, the net power input, and the COP are to be investigated.

Analysis The problem is solved using EES, and the solution is given below.

"Input data"

T[1] = 7 [C]
 P[1] = 35 [kPa]
 T[3] = 37 [C]
 P[3] = 160 [kPa]
 m_dot = 0.2 [kg/s]
 Eta_comp = 1.00
 Eta_turb = 1.0

"Compressor analysis"

s[1] = ENTROPY(Air, T=T[1], P=P[1])
 s2s = s[1] "For the ideal case the entropies are constant across the compressor"
 P[2] = P[3]
 s2s = ENTROPY(Air, T=Ts2, P=P[2]) "Ts2 is the isentropic value of T[2] at compressor exit"
 Eta_comp = W_dot_comp_isen / W_dot_comp "compressor adiabatic efficiency,
 W_dot_comp > W_dot_comp_isen"
 m_dot * h[1] + W_dot_comp_isen = m_dot * h[2] "SSSF First Law for the isentropic compressor,
 assuming: adiabatic, ke=pe=0, m_dot is the mass flow rate in kg/s"
 h[1] = ENTHALPY(Air, T=T[1])
 hs2 = ENTHALPY(Air, T=Ts2)
 m_dot * h[1] + W_dot_comp = m_dot * h[2] "SSSF First Law for the actual compressor,
 assuming: adiabatic, ke=pe=0"
 h[2] = ENTHALPY(Air, T=T[2])
 s[2] = ENTROPY(Air, h=h[2], P=P[2])

"Heat Rejection Process 2-3, assumed SSSF constant pressure process"

m_dot * h[2] + Q_dot_out = m_dot * h[3] "SSSF First Law for the heat exchanger,
 assuming W=0, ke=pe=0"
 h[3] = ENTHALPY(Air, T=T[3])

"Turbine analysis"

s[3] = ENTROPY(Air, T=T[3], P=P[3])
 s4s = s[3] "For the ideal case the entropies are constant across the turbine"
 P[4] = P[1]
 s4s = ENTROPY(Air, T=Ts4, P=P[4]) "Ts4 is the isentropic value of T[4] at turbine exit"
 Eta_turb = W_dot_turb / W_dot_turb_isen "turbine adiabatic efficiency, W_dot_turb_isen > W_dot_turb"
 m_dot * h[3] = W_dot_turb_isen + m_dot * hs4 "SSSF First Law for the isentropic turbine, assuming:
 adiabatic, ke=pe=0"
 hs4 = ENTHALPY(Air, T=Ts4)
 m_dot * h[3] = W_dot_turb + m_dot * h[4] "SSSF First Law for the actual compressor, assuming:
 adiabatic, ke=pe=0"
 h[4] = ENTHALPY(Air, T=T[4])
 s[4] = ENTROPY(Air, h=h[4], P=P[4])

"Refrigeration effect:"

m_dot * h[4] + Q_dot_Refrig = m_dot * h[1]

"Cycle analysis"

W_dot_in_net = W_dot_comp - W_dot_turb "External work supplied to compressor"

COP = Q_dot_Refrig / W_dot_in_net

"The following is for plotting data only:"

Ts[1] = Ts2
 ss[1] = s2s
 Ts[2] = Ts4
 ss[2] = s4s

η_{comp}	COP	Q_{Refrig} [kW]	W_{innet} [kW]
0.7	0.3291	9.334	28.36
0.75	0.3668	9.334	25.45
0.8	0.4077	9.334	22.9
0.85	0.4521	9.334	20.65
0.9	0.5006	9.334	18.65
0.95	0.5538	9.334	16.86
1	0.6123	9.334	15.24

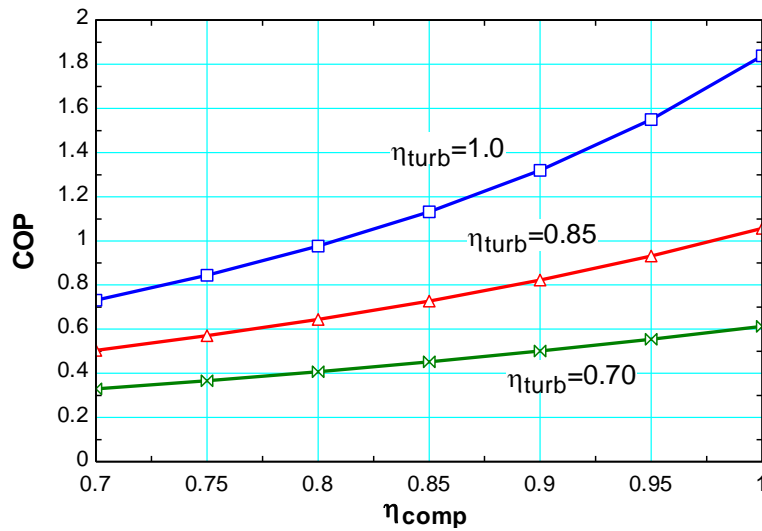
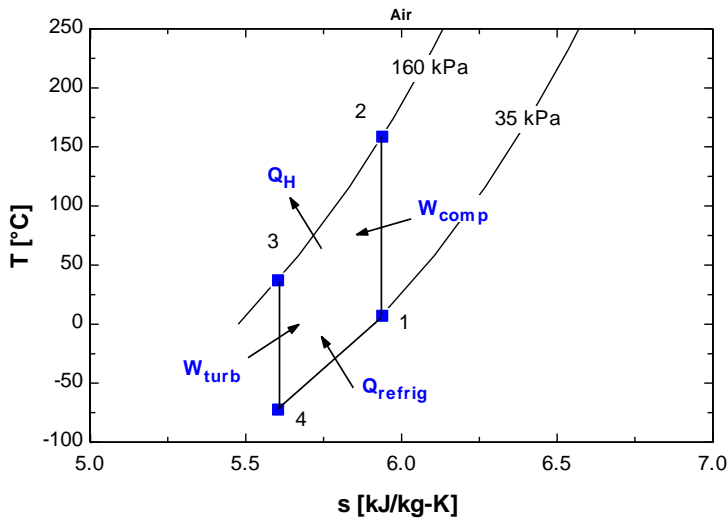

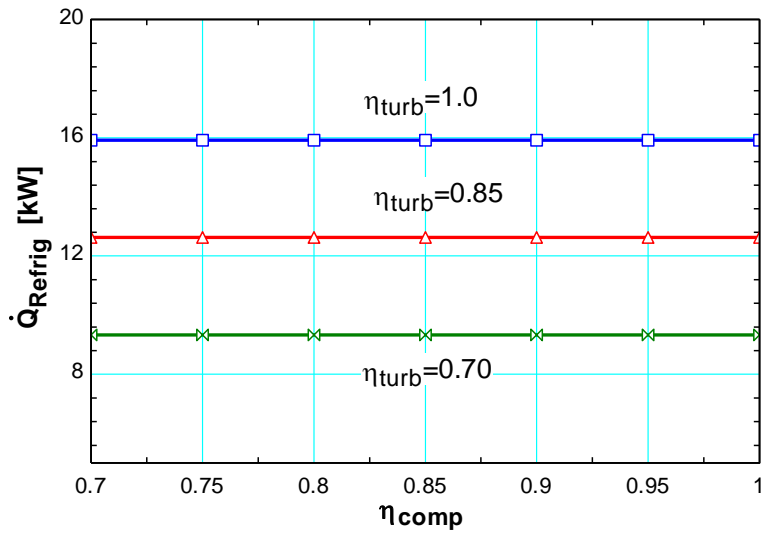
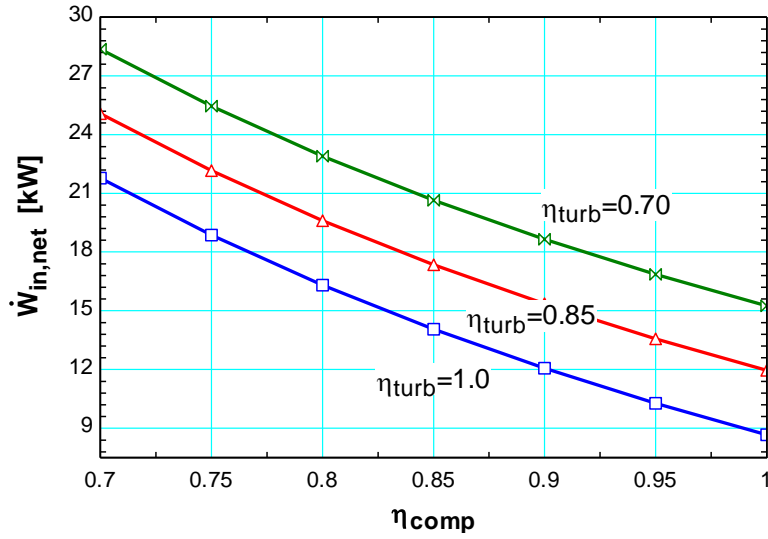

11-73 A gas refrigeration cycle with helium as the working fluid is considered. The minimum temperature in the cycle, the COP, and the mass flow rate of the helium are to be determined.

Assumptions 1 Steady operating conditions exist. 2 Helium is an ideal gas with constant specific heats. 3 Kinetic and potential energy changes are negligible.

Properties The properties of helium are $c_p = 5.1926 \text{ kJ/kg}\cdot\text{K}$ and $k = 1.667$ (Table A-2).

Analysis (a) From the isentropic relations,

$$T_{2s} = T_1 \left(\frac{P_2}{P_1} \right)^{(k-1)/k} = (267 \text{ K})(4)^{0.667/1.667} = 465.0 \text{ K}$$

$$T_{4s} = T_3 \left(\frac{P_4}{P_3} \right)^{(k-1)/k} = (323 \text{ K}) \left(\frac{1}{4} \right)^{0.667/1.667} = 185.5 \text{ K}$$

and

$$\eta_T = \frac{h_3 - h_4}{h_3 - h_{4s}} = \frac{T_3 - T_4}{T_3 - T_{4s}} \longrightarrow T_4 = T_3 - \eta_T(T_3 - T_{4s}) = 323 - (0.85)(323 - 185.5) = 206.1 \text{ K} = T_{\min}$$

$$\eta_C = \frac{h_{2s} - h_1}{h_2 - h_1} = \frac{T_{2s} - T_1}{T_2 - T_1} \longrightarrow T_2 = T_1 + (T_{2s} - T_1)/\eta_C = 267 + (465.0 - 267)/(0.85) = 499.9 \text{ K}$$

(b) The COP of this gas refrigeration cycle is determined from

$$\begin{aligned} \text{COP}_R &= \frac{q_L}{w_{\text{net,in}}} = \frac{q_L}{w_{\text{comp,in}} - w_{\text{turb,out}}} \\ &= \frac{h_1 - h_4}{(h_2 - h_1) - (h_3 - h_4)} \\ &= \frac{T_1 - T_4}{(T_2 - T_1) - (T_3 - T_4)} \\ &= \frac{267 - 206.1}{(499.9 - 267) - (323 - 206.1)} \\ &= \mathbf{0.525} \end{aligned}$$

(c) The mass flow rate of helium is determined from

$$\dot{m} = \frac{\dot{Q}_{\text{refrig}}}{q_L} = \frac{\dot{Q}_{\text{refrig}}}{h_1 - h_4} = \frac{\dot{Q}_{\text{refrig}}}{c_p(T_1 - T_4)} = \frac{25 \text{ kJ/s}}{(5.1926 \text{ kJ/kg}\cdot\text{K})(267 - 206.1) \text{ K}} = \mathbf{0.0791 \text{ kg/s}}$$

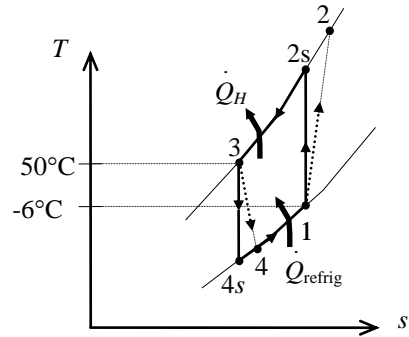

11-74 An ideal-gas refrigeration cycle with air as the working fluid is considered. The lowest temperature that can be obtained by this cycle, the COP, and the mass flow rate of air are to be determined.

Assumptions 1 Steady operating conditions exist. 2 Air is an ideal gas with constant specific heats. 3 Kinetic and potential energy changes are negligible.

Properties The properties of air at room temperature are $c_p = 1.005 \text{ kJ/kg}\cdot\text{K}$ and $k = 1.4$ (Table A-2).

Analysis (a) The lowest temperature in the cycle occurs at the turbine exit. From the isentropic relations,

$$T_2 = T_1 \left(\frac{P_2}{P_1} \right)^{(k-1)/k} = (266 \text{ K})(4)^{0.4/1.4} = 395.3 \text{ K} = 122.3^\circ\text{C}$$

$$T_5 = T_4 \left(\frac{P_5}{P_4} \right)^{(k-1)/k} = (258 \text{ K}) \left(\frac{1}{4} \right)^{0.4/1.4} = 173.6 \text{ K} = -99.4^\circ\text{C} = T_{\min}$$

(b) From an energy balance on the regenerator,

$$\dot{E}_{\text{in}} - \dot{E}_{\text{out}} = \Delta \dot{E}_{\text{system}} \stackrel{\phi^0(\text{steady})}{=} 0$$

$$\dot{E}_{\text{in}} = \dot{E}_{\text{out}}$$

$$\sum \dot{m}_e h_e = \sum \dot{m}_i h_i \longrightarrow \dot{m}(h_3 - h_4) = \dot{m}(h_1 - h_6)$$

or,

$$\dot{m} c_p (T_3 - T_4) = \dot{m} c_p (T_1 - T_6) \longrightarrow T_3 - T_4 = T_1 - T_6$$

or,

$$T_6 = T_1 - T_3 + T_4 = (-7^\circ\text{C}) - 27^\circ\text{C} + (-15^\circ\text{C}) = -49^\circ\text{C}$$

Then the COP of this ideal gas refrigeration cycle is determined from

$$\begin{aligned} \text{COP}_R &= \frac{q_L}{w_{\text{net,in}}} = \frac{q_L}{w_{\text{comp,in}} - w_{\text{turb,out}}} \\ &= \frac{h_6 - h_5}{(h_2 - h_1) - (h_4 - h_3)} \\ &= \frac{T_6 - T_5}{(T_2 - T_1) - (T_4 - T_3)} \\ &= \frac{-49^\circ\text{C} - (-99.4^\circ\text{C})}{[122.3 - (-7)]^\circ\text{C} - [-15 - (-99.4)]^\circ\text{C}} = \mathbf{1.12} \end{aligned}$$

(c) The mass flow rate is determined from

$$\dot{m} = \frac{\dot{Q}_{\text{refrig}}}{q_L} = \frac{\dot{Q}_{\text{refrig}}}{h_6 - h_5} = \frac{\dot{Q}_{\text{refrig}}}{c_p (T_6 - T_5)} = \frac{12 \text{ kJ/s}}{(1.005 \text{ kJ/kg}\cdot^\circ\text{C})[-49 - (-99.4)]^\circ\text{C}} = \mathbf{0.237 \text{ kg/s}}$$

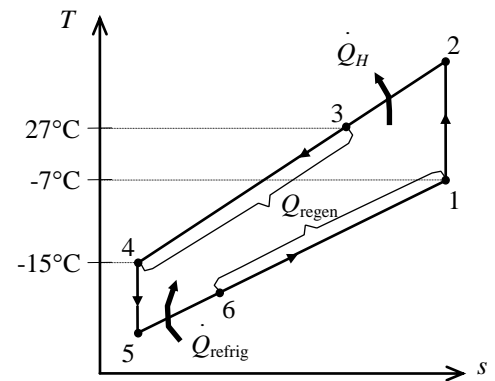

11-75 An ideal-gas refrigeration cycle with air as the working fluid is considered. The lowest temperature that can be obtained by this cycle, the COP, and the mass flow rate of air are to be determined.

Assumptions 1 Steady operating conditions exist. 2 Air is an ideal gas with constant specific heats. 3 Kinetic and potential energy changes are negligible.

Properties The properties of air at room temperature are $c_p = 1.005$ kJ/kg·K and $k = 1.4$ (Table A-2).

Analysis (a) The lowest temperature in the cycle occurs at the turbine exit. From the isentropic relations,

$$T_{2s} = T_1 \left(\frac{P_2}{P_1} \right)^{(k-1)/k} = (266 \text{ K})(4)^{0.4/1.4} = 395.3 \text{ K} = 122.3^\circ\text{C}$$

$$T_{5s} = T_4 \left(\frac{P_5}{P_4} \right)^{(k-1)/k} = (258 \text{ K}) \left(\frac{1}{4} \right)^{0.4/1.4} = 173.6 \text{ K} = -99.4^\circ\text{C}$$

and

$$\eta_T = \frac{h_4 - h_5}{h_4 - h_{5s}} = \frac{T_4 - T_5}{T_4 - T_{5s}} \longrightarrow T_5 = T_4 - \eta_T(T_4 - T_{5s}) = -15 - (0.80)(-15 - (-99.4)) = -82.5^\circ\text{C} = T_{\min}$$

$$\eta_C = \frac{h_{2s} - h_1}{h_2 - h_1} = \frac{T_{2s} - T_1}{T_2 - T_1} \longrightarrow T_2 = T_1 + (T_{2s} - T_1)/\eta_C = -7 + (122.3 - (-7))/(0.75) = 165.4^\circ\text{C}$$

(b) From an energy balance on the regenerator,

$$\begin{aligned} \dot{E}_{\text{in}} - \dot{E}_{\text{out}} &= \Delta \dot{E}_{\text{system}} \stackrel{\neq 0 \text{ (steady)}}{=} 0 \longrightarrow \dot{E}_{\text{in}} = \dot{E}_{\text{out}} \\ \sum \dot{m}_e h_e &= \sum \dot{m}_i h_i \longrightarrow \dot{m}(h_3 - h_4) = \dot{m}(h_1 - h_6) \end{aligned}$$

or,

$$\dot{m} c_p (T_3 - T_4) = \dot{m} c_p (T_1 - T_6) \longrightarrow T_3 - T_4 = T_1 - T_6$$

or,

$$T_6 = T_1 - T_3 + T_4 = (-7^\circ\text{C}) - 27^\circ\text{C} + (-15^\circ\text{C}) = -49^\circ\text{C}$$

Then the COP of this ideal gas refrigeration cycle is determined from

$$\begin{aligned} \text{COP}_R &= \frac{q_L}{w_{\text{net,in}}} = \frac{q_L}{w_{\text{comp,in}} - w_{\text{turb,out}}} \\ &= \frac{h_6 - h_5}{(h_2 - h_1) - (h_4 - h_5)} \\ &= \frac{T_6 - T_5}{(T_2 - T_1) - (T_4 - T_5)} \\ &= \frac{-49^\circ\text{C} - (-82.5^\circ\text{C})}{[165.4 - (-7)]^\circ\text{C} - [-15 - (-82.5)]^\circ\text{C}} = \mathbf{0.32} \end{aligned}$$

(c) The mass flow rate is determined from

$$\dot{m} = \frac{\dot{Q}_{\text{refrig}}}{q_L} = \frac{\dot{Q}_{\text{refrig}}}{h_6 - h_5} = \frac{\dot{Q}_{\text{refrig}}}{c_p(T_6 - T_5)} = \frac{12 \text{ kJ/s}}{(1.005 \text{ kJ/kg}\cdot^\circ\text{C})[-49 - (-82.5)]^\circ\text{C}} = \mathbf{0.356 \text{ kg/s}}$$

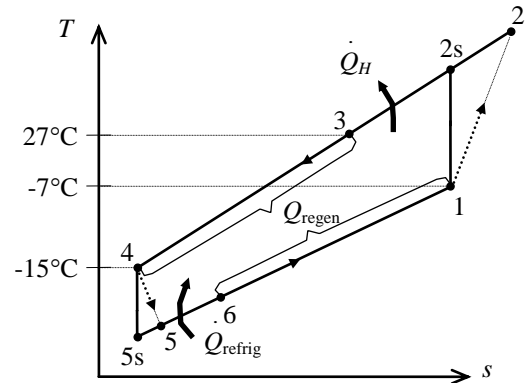

11-76 A regenerative gas refrigeration cycle using air as the working fluid is considered. The effectiveness of the regenerator, the rate of heat removal from the refrigerated space, the COP of the cycle, and the refrigeration load and the COP if this system operated on the simple gas refrigeration cycle are to be determined.

Assumptions 1 Steady operating conditions exist. 2 Kinetic and potential energy changes are negligible. 3 Air is an ideal gas with constant specific heats.

Properties The properties of air at room temperature are $c_p = 1.005 \text{ kJ/kg}\cdot\text{K}$ and $k = 1.4$ (Table A-2).

Analysis (a) From the isentropic relations,

$$T_{2s} = T_1 \left(\frac{P_2}{P_1} \right)^{(k-1)/k} = (273.2 \text{ K})(5)^{0.4/1.4} = 432.4 \text{ K}$$

$$\eta_C = \frac{h_{2s} - h_1}{h_2 - h_1} = \frac{T_{2s} - T_1}{T_2 - T_1}$$

$$0.80 = \frac{432.4 - 273.2}{T_2 - 273.2} \rightarrow T_2 = 472.5 \text{ K}$$

The temperature at state 4 can be determined by solving the following two equations simultaneously:

$$T_{5s} = T_4 \left(\frac{P_5}{P_4} \right)^{(k-1)/k} = T_4 \left(\frac{1}{5} \right)^{0.4/1.4}$$

$$\eta_T = \frac{h_4 - h_5}{h_4 - h_{5s}} \rightarrow 0.85 = \frac{T_4 - 193.2}{T_4 - T_{5s}}$$

Using EES, we obtain $T_4 = 281.3 \text{ K}$.

An energy balance on the regenerator may be written as

$$\dot{m}c_p(T_3 - T_4) = \dot{m}c_p(T_1 - T_6) \rightarrow T_3 - T_4 = T_1 - T_6$$

or,

$$T_6 = T_1 - T_3 + T_4 = 273.2 - 308.2 + 281.3 = 246.3 \text{ K}$$

The effectiveness of the regenerator is

$$\varepsilon_{\text{regen}} = \frac{h_3 - h_4}{h_3 - h_6} = \frac{T_3 - T_4}{T_3 - T_6} = \frac{308.2 - 281.3}{308.2 - 246.3} = \mathbf{0.434}$$

(b) The refrigeration load is

$$\dot{Q}_L = \dot{m}c_p(T_6 - T_5) = (0.4 \text{ kg/s})(1.005 \text{ kJ/kg}\cdot\text{K})(246.3 - 193.2) \text{ K} = \mathbf{21.36 \text{ kW}}$$

(c) The turbine and compressor powers and the COP of the cycle are

$$\dot{W}_{C,\text{in}} = \dot{m}c_p(T_2 - T_1) = (0.4 \text{ kg/s})(1.005 \text{ kJ/kg}\cdot\text{K})(472.5 - 273.2) \text{ K} = 80.13 \text{ kW}$$

$$\dot{W}_{T,\text{out}} = \dot{m}c_p(T_4 - T_5) = (0.4 \text{ kg/s})(1.005 \text{ kJ/kg}\cdot\text{K})(281.3 - 193.2) \text{ K} = 35.43 \text{ kW}$$

$$\text{COP} = \frac{\dot{Q}_L}{\dot{W}_{\text{net,in}}} = \frac{\dot{Q}_L}{\dot{W}_{C,\text{in}} - \dot{W}_{T,\text{out}}} = \frac{21.36}{80.13 - 35.43} = \mathbf{0.478}$$

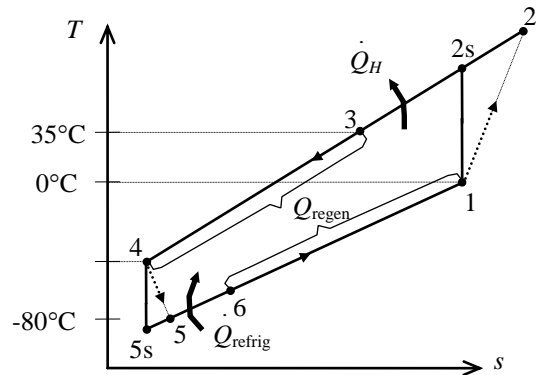
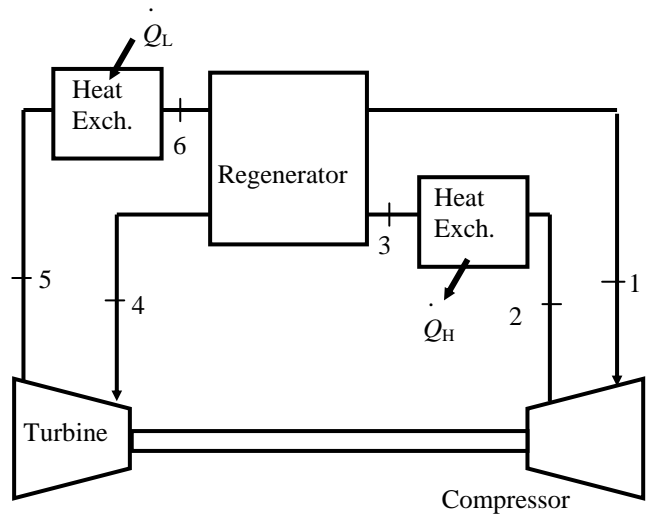

(d) The simple gas refrigeration cycle analysis is as follows:

$$T_{4s} = T_3 \left(\frac{1}{r} \right)^{(k-1)/k} = (308.2 \text{ K}) \left(\frac{1}{5} \right)^{0.4/1.4} = 194.6 \text{ K}$$

$$\eta_T = \frac{T_3 - T_4}{T_3 - T_{4s}} \rightarrow 0.85 = \frac{308.2 - T_4}{308.2 - 194.6} \rightarrow T_4 = 211.6 \text{ K}$$

$$\begin{aligned} \dot{Q}_L &= \dot{m} c_p (T_1 - T_4) \\ &= (0.4 \text{ kg/s})(1.005 \text{ kJ/kg}\cdot\text{K})(273.2 - 211.6) \text{ kJ/kg} \\ &= \mathbf{24.74 \text{ kW}} \end{aligned}$$

$$\begin{aligned} \dot{W}_{\text{net,in}} &= \dot{m} c_p (T_2 - T_1) - \dot{m} c_p (T_3 - T_4) \\ &= (0.4 \text{ kg/s})(1.005 \text{ kJ/kg}\cdot\text{K})[(472.5 - 273.2) - (308.2 - 211.6) \text{ kJ/kg}] \\ &= 41.32 \text{ kW} \end{aligned}$$

$$\text{COP} = \frac{\dot{Q}_L}{\dot{W}_{\text{net,in}}} = \frac{24.74}{41.32} = \mathbf{0.599}$$

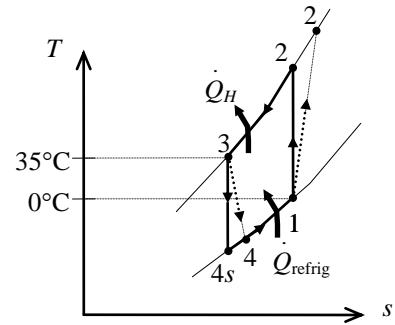

11-77 An ideal gas refrigeration cycle with two stages of compression with intercooling using air as the working fluid is considered. The COP of this system and the mass flow rate of air are to be determined.

Assumptions 1 Steady operating conditions exist. 2 Air is an ideal gas with constant specific heats. 3 Kinetic and potential energy changes are negligible.

Properties The properties of air at room temperature are $c_p = 1.005 \text{ kJ/kg}\cdot\text{K}$ and $k = 1.4$ (Table A-2a).

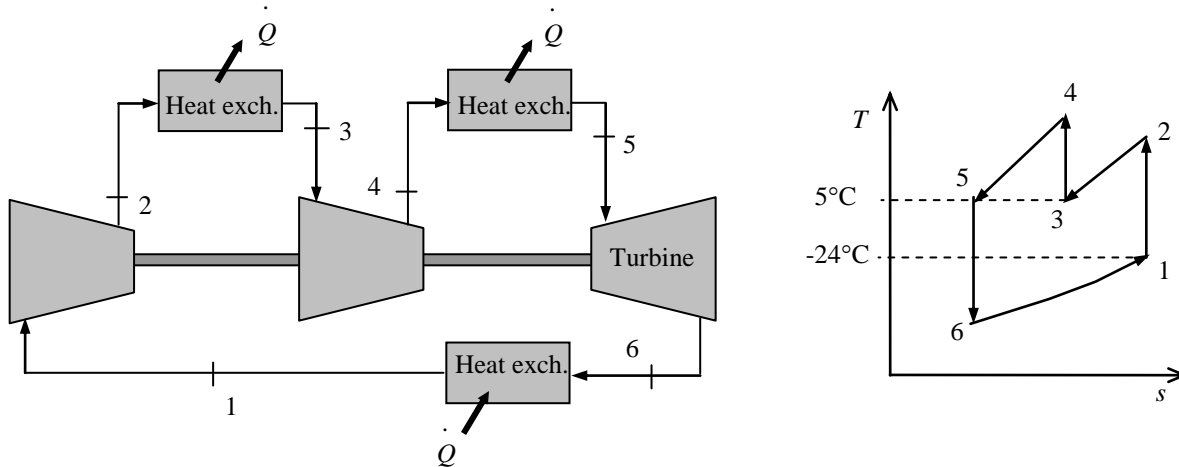

Analysis From the isentropic relations,

$$T_2 = T_1 \left(\frac{P_2}{P_1} \right)^{(k-1)/k} = (249 \text{ K})(3)^{0.4/1.4} = 340.8 \text{ K}$$

$$T_4 = T_3 \left(\frac{P_4}{P_3} \right)^{(k-1)/k} = (278 \text{ K})(3)^{0.4/1.4} = 380.5 \text{ K}$$

$$T_6 = T_5 \left(\frac{P_6}{P_5} \right)^{(k-1)/k} = (278 \text{ K}) \left(\frac{1}{9} \right)^{0.4/1.4} = 148.4 \text{ K}$$

The COP of this ideal gas refrigeration cycle is determined from

$$\begin{aligned} \text{COP}_R &= \frac{q_L}{w_{\text{net,in}}} = \frac{q_L}{w_{\text{comp,in}} - w_{\text{turb,out}}} \\ &= \frac{h_1 - h_6}{(h_2 - h_1) + (h_4 - h_3) - (h_5 - h_6)} \\ &= \frac{T_1 - T_6}{(T_2 - T_1) + (T_4 - T_3) - (T_5 - T_6)} \\ &= \frac{249 - 148.4}{(340.8 - 249) + (380.5 - 278) - (278 - 148.4)} \\ &= \mathbf{1.56} \end{aligned}$$

The mass flow rate of the air is determined from

$$\dot{Q}_{\text{Refrig}} = \dot{m} c_p (T_1 - T_6) \longrightarrow \dot{m} = \frac{\dot{Q}_{\text{Refrig}}}{c_p (T_1 - T_6)} = \frac{(45,000/3600) \text{ kJ/s}}{(1.005 \text{ kJ/kg}\cdot\text{K})(249 - 148.4) \text{ K}} = \mathbf{0.124 \text{ kg/s}}$$

11-78 A gas refrigeration cycle with two stages of compression with intercooling using air as the working fluid is considered. The COP of this system and the mass flow rate of air are to be determined.

Assumptions 1 Steady operating conditions exist. 2 Air is an ideal gas with constant specific heats. 3 Kinetic and potential energy changes are negligible.

Properties The properties of air at room temperature are $c_p = 1.005 \text{ kJ/kg}\cdot\text{K}$ and $k = 1.4$ (Table A-2a).

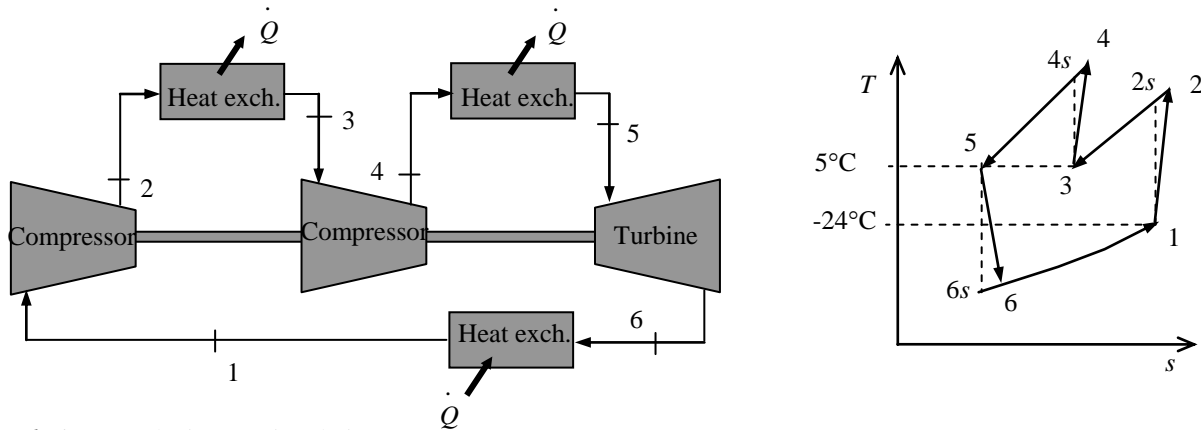

Analysis From the isentropic relations,

$$T_{2s} = T_1 \left(\frac{P_2}{P_1} \right)^{(k-1)/k} = (249 \text{ K})(3)^{0.4/1.4} = 340.8 \text{ K}$$

$$T_{4s} = T_3 \left(\frac{P_4}{P_3} \right)^{(k-1)/k} = (278 \text{ K})(3)^{0.4/1.4} = 380.5 \text{ K}$$

$$T_{6s} = T_5 \left(\frac{P_6}{P_5} \right)^{(k-1)/k} = (278 \text{ K}) \left(\frac{1}{9} \right)^{0.4/1.4} = 148.4 \text{ K}$$

and

$$\eta_C = \frac{h_{2s} - h_1}{h_2 - h_1} = \frac{T_{2s} - T_1}{T_2 - T_1} \longrightarrow T_2 = T_1 + (T_{2s} - T_1) / \eta_C = 249 + (340.8 - 249) / 0.85 = 357.0 \text{ K}$$

$$\eta_C = \frac{h_{4s} - h_3}{h_4 - h_3} = \frac{T_{4s} - T_3}{T_4 - T_3} \longrightarrow T_4 = T_3 + (T_{4s} - T_3) / \eta_C = 278 + (380.5 - 278) / 0.85 = 398.6 \text{ K}$$

$$\eta_T = \frac{h_5 - h_6}{h_5 - h_{6s}} = \frac{T_5 - T_6}{T_5 - T_{6s}} \longrightarrow T_6 = T_5 - \eta_T (T_5 - T_{6s}) = 278 - (0.95)(278 - 148.4) = 154.9 \text{ K}$$

The COP of this ideal gas refrigeration cycle is determined from

$$\begin{aligned} \text{COP}_R &= \frac{q_L}{w_{\text{net,in}}} = \frac{q_L}{w_{\text{comp,in}} - w_{\text{turb,out}}} \\ &= \frac{h_1 - h_6}{(h_2 - h_1) + (h_4 - h_3) - (h_5 - h_6)} \\ &= \frac{T_1 - T_6}{(T_2 - T_1) + (T_4 - T_3) - (T_5 - T_6)} \\ &= \frac{249 - 154.9}{(357.0 - 249) + (398.6 - 278) - (278 - 154.9)} = \mathbf{0.892} \end{aligned}$$

The mass flow rate of the air is determined from

$$\dot{Q}_{\text{Refrig}} = \dot{m} c_p (T_1 - T_6) \longrightarrow \dot{m} = \frac{\dot{Q}_{\text{Refrig}}}{c_p (T_1 - T_6)} = \frac{(45,000 / 3600) \text{ kJ/s}}{(1.005 \text{ kJ/kg}\cdot\text{K})(249 - 154.9) \text{ K}} = \mathbf{0.132 \text{ kg/s}}$$

Absorption Refrigeration Systems

11-79C Absorption refrigeration is the kind of refrigeration that involves the absorption of the refrigerant during part of the cycle. In absorption refrigeration cycles, the refrigerant is compressed in the liquid phase instead of in the vapor form.

11-80C The main advantage of absorption refrigeration is its being economical in the presence of an inexpensive heat source. Its disadvantages include being expensive, complex, and requiring an external heat source.

11-81C The fluid in the absorber is cooled to maximize the refrigerant content of the liquid; the fluid in the generator is heated to maximize the refrigerant content of the vapor.

11-82C The coefficient of performance of absorption refrigeration systems is defined as

$$\text{COP}_R = \frac{\text{desired output}}{\text{required input}} = \frac{Q_L}{Q_{\text{gen}} + W_{\text{pump in}}} \cong \frac{Q_L}{Q_{\text{gen}}}$$

11-83 The COP of an absorption refrigeration system that operates at specified conditions is given. It is to be determined whether the given COP value is possible.

Analysis The maximum COP that this refrigeration system can have is

$$\text{COP}_{R,\text{max}} = \left(1 - \frac{T_0}{T_s}\right) \left(\frac{T_L}{T_0 - T_L}\right) = \left(1 - \frac{292 \text{ K}}{368 \text{ K}}\right) \left(\frac{273}{292 - 273}\right) = 2.97$$

which is smaller than 3.1. Thus the claim is **not possible**.

11-84 The conditions at which an absorption refrigeration system operates are specified. The maximum COP this absorption refrigeration system can have is to be determined.

Analysis The maximum COP that this refrigeration system can have is

$$\text{COP}_{R,\text{max}} = \left(1 - \frac{T_0}{T_s}\right) \left(\frac{T_L}{T_0 - T_L}\right) = \left(1 - \frac{298 \text{ K}}{393 \text{ K}}\right) \left(\frac{273}{298 - 273}\right) = \mathbf{2.64}$$

11-85 The conditions at which an absorption refrigeration system operates are specified. The maximum rate at which this system can remove heat from the refrigerated space is to be determined.

Analysis The maximum COP that this refrigeration system can have is

$$\text{COP}_{\text{R,max}} = \left(1 - \frac{T_0}{T_s}\right) \left(\frac{T_L}{T_0 - T_L}\right) = \left(1 - \frac{298 \text{ K}}{383 \text{ K}}\right) \left(\frac{255}{298 - 255}\right) = 1.316$$

Thus,

$$\dot{Q}_{\text{L,max}} = \text{COP}_{\text{R,max}} \dot{Q}_{\text{gen}} = (1.316)(5 \times 10^5 \text{ kJ/h}) = \mathbf{6.58 \times 10^5 \text{ kJ/h}}$$

11-86 A reversible absorption refrigerator consists of a reversible heat engine and a reversible refrigerator. The rate at which the steam condenses, the power input to the reversible refrigerator, and the second law efficiency of an actual chiller are to be determined.

Properties The enthalpy of vaporization of water at 150°C is $h_{fg} = 2113.8 \text{ kJ/kg}$ (Table A-4).

Analysis (a) The thermal efficiency of the reversible heat engine is

$$\eta_{\text{th,rev}} = 1 - \frac{T_0}{T_s} = 1 - \frac{(25 + 273.15) \text{ K}}{(150 + 273.15) \text{ K}} = 0.2954$$

The COP of the reversible refrigerator is

$$\text{COP}_{\text{R,rev}} = \frac{T_L}{T_0 - T_L} = \frac{(-15 + 273.15) \text{ K}}{(25 + 273.15) - (-15 + 273.15) \text{ K}} = 6.454$$

The COP of the reversible absorption refrigerator is

$$\text{COP}_{\text{abs,rev}} = \eta_{\text{th,rev}} \text{COP}_{\text{R,rev}} = (0.2954)(6.454) = 1.906$$

The heat input to the reversible heat engine is

$$\dot{Q}_{\text{in}} = \frac{\dot{Q}_{\text{L}}}{\text{COP}_{\text{abs,rev}}} = \frac{70 \text{ kW}}{1.906} = 36.72 \text{ kW}$$

Then, the rate at which the steam condenses becomes

$$\dot{m}_s = \frac{\dot{Q}_{\text{in}}}{h_{fg}} = \frac{36.72 \text{ kJ/s}}{2113.8 \text{ kJ/kg}} = \mathbf{0.0174 \text{ kg/s}}$$

(b) The power input to the refrigerator is equal to the power output from the heat engine

$$\dot{W}_{\text{in,R}} = \dot{W}_{\text{out,HE}} = \eta_{\text{th,rev}} \dot{Q}_{\text{in}} = (0.2954)(36.72 \text{ kW}) = \mathbf{10.9 \text{ kW}}$$

(c) The second-law efficiency of an actual absorption chiller with a COP of 0.8 is

$$\eta_{\text{II}} = \frac{\text{COP}_{\text{actual}}}{\text{COP}_{\text{abs,rev}}} = \frac{0.8}{1.906} = 0.420 = \mathbf{42.0\%}$$

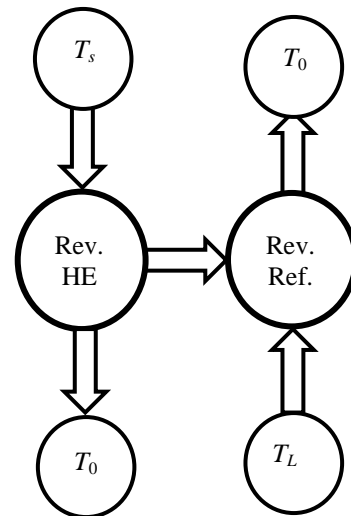

11-87E An ammonia-water absorption refrigeration cycle is considered. The rate of cooling, the COP, and the second-law efficiency of the system are to be determined.

Assumptions 1 Steady operating conditions exist. 2 Kinetic and potential energy changes are negligible.

Properties The properties of ammonia are as given in the problem statement. The specific heat of geothermal water is given to be 1.0 Btu/lbm·°F.

Analysis (a) The rate of cooling provided by the system is

$$\begin{aligned}\dot{Q}_L &= \dot{m}_R(h_1 - h_4) = (0.04 \text{ lbm/s})(619.2 - 190.9) \text{ Btu/lbm} \\ &= 17.13 \text{ Btu/s} = \mathbf{61,700 \text{ Btu/h}}\end{aligned}$$

(b) The rate of heat input to the generator is

$$\dot{Q}_{\text{gen}} = \dot{m}_{\text{geo}} c_p (T_{\text{geo;in}} - T_{\text{geo;out}}) = (0.55 \text{ lbm/s})(1.0 \text{ Btu/lbm} \cdot \text{°F})(240 - 200) \text{°F} = 22.0 \text{ Btu/s}$$

Then the COP becomes

$$\text{COP} = \frac{\dot{Q}_L}{\dot{Q}_{\text{gen}}} = \frac{17.13 \text{ Btu/s}}{22.0 \text{ Btu/s}} = \mathbf{0.779}$$

(c) The reversible COP of the system is

$$\text{COP}_{\text{abs,rev}} = \left(1 - \frac{T_0}{T_s}\right) \left(\frac{T_L}{T_0 - T_L}\right) = \left(1 - \frac{(70 + 460)}{(220 + 460)}\right) \left(\frac{(25 + 460)}{70 - 25}\right) = 2.38$$

The temperature of the heat source is taken as the average temperature of the geothermal water: $(240 + 200)/2 = 220 \text{°F}$. Then the second-law efficiency becomes

$$\eta_{\text{II}} = \frac{\text{COP}}{\text{COP}_{\text{abs,rev}}} = \frac{0.779}{2.38} = 0.328 = \mathbf{32.8\%}$$

Special Topic: Thermoelectric Power Generation and Refrigeration Systems

11-88C The circuit that incorporates both thermal and electrical effects is called a thermoelectric circuit.

11-89C When two wires made from different metals joined at both ends (junctions) forming a closed circuit and one of the joints is heated, a current flows continuously in the circuit. This is called the Seebeck effect. When a small current is passed through the junction of two dissimilar wires, the junction is cooled. This is called the Peltier effect.

11-90C No.

11-91C No.

11-92C Yes.

11-93C When a thermoelectric circuit is broken, the current will cease to flow, and we can measure the voltage generated in the circuit by a voltmeter. The voltage generated is a function of the temperature difference, and the temperature can be measured by simply measuring voltages.

11-94C The performance of thermoelectric refrigerators improves considerably when semiconductors are used instead of metals.

11-95C The efficiency of a thermoelectric generator is limited by the Carnot efficiency because a thermoelectric generator fits into the definition of a heat engine with electrons serving as the working fluid.

11-96E A thermoelectric generator that operates at specified conditions is considered. The maximum thermal efficiency this thermoelectric generator can have is to be determined.

Analysis The maximum thermal efficiency of this thermoelectric generator is the Carnot efficiency,

$$\eta_{\text{th,max}} = \eta_{\text{th,Carnot}} = 1 - \frac{T_L}{T_H} = 1 - \frac{550\text{R}}{800\text{R}} = \mathbf{31.3\%}$$

11-97 A thermoelectric refrigerator that operates at specified conditions is considered. The maximum COP this thermoelectric refrigerator can have and the minimum required power input are to be determined.

Analysis The maximum COP of this thermoelectric refrigerator is the COP of a Carnot refrigerator operating between the same temperature limits,

$$\text{COP}_{\text{max}} = \text{COP}_{\text{R,Carnot}} = \frac{1}{(T_H / T_L) - 1} = \frac{1}{(293\text{ K}) / (268\text{ K}) - 1} = \mathbf{10.72}$$

Thus,

$$\dot{W}_{\text{in,min}} = \frac{\dot{Q}_L}{\text{COP}_{\text{max}}} = \frac{130\text{ W}}{10.72} = \mathbf{12.1\text{ W}}$$

11-98 A thermoelectric cooler that operates at specified conditions with a given COP is considered. The required power input to the thermoelectric cooler is to be determined.

Analysis The required power input is determined from the definition of COP_R,

$$\text{COP}_R = \frac{\dot{Q}_L}{\dot{W}_{\text{in}}} \longrightarrow \dot{W}_{\text{in}} = \frac{\dot{Q}_L}{\text{COP}_R} = \frac{180 \text{ W}}{0.15} = \mathbf{1200 \text{ W}}$$

11-99E A thermoelectric cooler that operates at specified conditions with a given COP is considered. The rate of heat removal is to be determined.

Analysis The required power input is determined from the definition of COP_R,

$$\text{COP}_R = \frac{\dot{Q}_L}{\dot{W}_{\text{in}}} \longrightarrow \dot{Q}_L = \text{COP}_R \dot{W}_{\text{in}} = (0.18)(1.8 \text{ hp}) \left(\frac{42.41 \text{ Btu/min}}{1 \text{ hp}} \right) = \mathbf{13.7 \text{ Btu/min}}$$

11-100 A thermoelectric refrigerator powered by a car battery cools 9 canned drinks in 12 h. The average COP of this refrigerator is to be determined.

Assumptions Heat transfer through the walls of the refrigerator is negligible.

Properties The properties of canned drinks are the same as those of water at room temperature, $\rho = 1 \text{ kg/L}$ and $c_p = 4.18 \text{ kJ/kg}\cdot^\circ\text{C}$ (Table A-3).

Analysis The cooling rate of the refrigerator is simply the rate of decrease of the energy of the canned drinks,

$$\begin{aligned} m &= \rho V = 9 \times (1 \text{ kg/L})(0.350 \text{ L}) = 3.15 \text{ kg} \\ Q_{\text{cooling}} &= mc\Delta T = (3.15 \text{ kg})(4.18 \text{ kJ/kg}\cdot^\circ\text{C})(25 - 3)^\circ\text{C} = 290 \text{ kJ} \\ \dot{Q}_{\text{cooling}} &= \frac{Q_{\text{cooling}}}{\Delta t} = \frac{290 \text{ kJ}}{12 \times 3600 \text{ s}} = 0.00671 \text{ kW} = 6.71 \text{ W} \end{aligned}$$

The electric power consumed by the refrigerator is

$$\dot{W}_{\text{in}} = VI = (12 \text{ V})(3 \text{ A}) = 36 \text{ W}$$

Then the COP of the refrigerator becomes

$$\text{COP} = \frac{\dot{Q}_{\text{cooling}}}{\dot{W}_{\text{in}}} = \frac{6.71 \text{ W}}{36 \text{ W}} = \mathbf{0.186} \approx 0.20$$

11-101E A thermoelectric cooler is said to cool a 12-oz drink or to heat a cup of coffee in about 15 min. The average rate of heat removal from the drink, the average rate of heat supply to the coffee, and the electric power drawn from the battery of the car are to be determined.

Assumptions Heat transfer through the walls of the refrigerator is negligible.

Properties The properties of canned drinks are the same as those of water at room temperature, $c_p = 1.0 \text{ Btu/lbm}\cdot^\circ\text{F}$ (Table A-3E).

Analysis (a) The average cooling rate of the refrigerator is simply the rate of decrease of the energy content of the canned drinks,

$$Q_{\text{cooling}} = mc_p \Delta T = (0.771 \text{ lbm})(1.0 \text{ Btu/lbm}\cdot^\circ\text{F})(78 - 38)^\circ\text{F} = 30.84 \text{ Btu}$$

$$\dot{Q}_{\text{cooling}} = \frac{Q_{\text{cooling}}}{\Delta t} = \frac{30.84 \text{ Btu}}{15 \times 60 \text{ s}} \left(\frac{1055 \text{ J}}{1 \text{ Btu}} \right) = \mathbf{36.2 \text{ W}}$$

(b) The average heating rate of the refrigerator is simply the rate of increase of the energy content of the canned drinks,

$$Q_{\text{heating}} = mc_p \Delta T = (0.771 \text{ lbm})(1.0 \text{ Btu/lbm}\cdot^\circ\text{F})(130 - 75)^\circ\text{F} = 42.4 \text{ Btu}$$

$$\dot{Q}_{\text{heating}} = \frac{Q_{\text{heating}}}{\Delta t} = \frac{42.4 \text{ Btu}}{15 \times 60 \text{ s}} \left(\frac{1055 \text{ J}}{1 \text{ Btu}} \right) = \mathbf{49.7 \text{ W}}$$

(c) The electric power drawn from the car battery during cooling and heating is

$$\dot{W}_{\text{in,cooling}} = \frac{\dot{Q}_{\text{cooling}}}{\text{COP}_{\text{cooling}}} = \frac{36.2 \text{ W}}{0.2} = \mathbf{181 \text{ W}}$$

$$\text{COP}_{\text{heating}} = \text{COP}_{\text{cooling}} + 1 = 0.2 + 1 = 1.2$$

$$\dot{W}_{\text{in,heating}} = \frac{\dot{Q}_{\text{heating}}}{\text{COP}_{\text{heating}}} = \frac{49.7 \text{ W}}{1.2} = \mathbf{41.4 \text{ W}}$$

11-102 The maximum power a thermoelectric generator can produce is to be determined.

Analysis The maximum thermal efficiency this thermoelectric generator can have is

$$\eta_{\text{th,max}} = 1 - \frac{T_L}{T_H} = 1 - \frac{295 \text{ K}}{363 \text{ K}} = 0.1873$$

Thus,

$$\dot{W}_{\text{out,max}} = \eta_{\text{th,max}} \dot{Q}_{\text{in}} = (0.1873)(7 \times 10^6 \text{ kJ/h}) = 1.31 \times 10^6 \text{ kJ/h} = \mathbf{364 \text{ kW}}$$

Review Problems

11-103 A house is cooled adequately by a 3.5 ton air-conditioning unit. The rate of heat gain of the house when the air-conditioner is running continuously is to be determined.

Assumptions 1 The heat gain includes heat transfer through the walls and the roof, infiltration heat gain, solar heat gain, internal heat gain, etc. **2** Steady operating conditions exist.

Analysis Noting that 1 ton of refrigeration is equivalent to a cooling rate of 211 kJ/min, the rate of heat gain of the house in steady operation is simply equal to the cooling rate of the air-conditioning system,

$$\dot{Q}_{\text{heat gain}} = \dot{Q}_{\text{cooling}} = (3.5 \text{ ton})(211 \text{ kJ/min}) = 738.5 \text{ kJ/min} = \mathbf{44,310 \text{ kJ/h}}$$

11-104 A steady-flow Carnot refrigeration cycle with refrigerant-134a as the working fluid is considered. The COP, the condenser and evaporator pressures, and the net work input are to be determined.

Assumptions 1 Steady operating conditions exist. **2** Kinetic and potential energy changes are negligible.

Analysis (a) The COP of this refrigeration cycle is determined from

$$\text{COP}_{\text{R,C}} = \frac{1}{(T_H/T_L) - 1} = \frac{1}{(303 \text{ K})/(253 \text{ K}) - 1} = \mathbf{5.060}$$

(b) The condenser and evaporative pressures are (Table A-11)

$$P_{\text{evap}} = P_{\text{sat}@-20^\circ\text{C}} = \mathbf{132.82 \text{ kPa}}$$

$$P_{\text{cond}} = P_{\text{sat}@30^\circ\text{C}} = \mathbf{770.64 \text{ kPa}}$$

(c) The net work input is determined from

$$h_1 = (h_f + x_1 h_{fg})_{@-20^\circ\text{C}} = 25.47 + (0.15)(212.96) = 57.42 \text{ kJ/kg}$$

$$h_2 = (h_f + x_2 h_{fg})_{@-20^\circ\text{C}} = 25.47 + (0.80)(212.96) = 195.84 \text{ kJ/kg}$$

$$q_L = h_2 - h_1 = 195.84 - 57.42 = 138.4 \text{ kJ/kg}$$

$$w_{\text{net,in}} = \frac{q_L}{\text{COP}_R} = \frac{138.4 \text{ kJ/kg}}{5.060} = \mathbf{27.36 \text{ kJ/kg}}$$

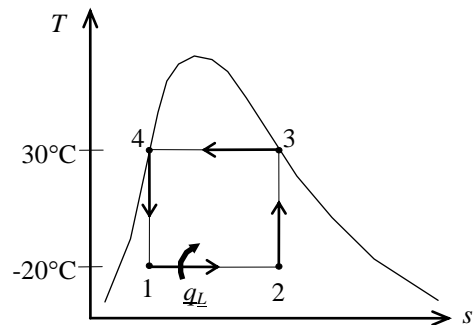

11-105 A heat pump water heater has a COP of 3.4 and consumes 6 kW when running. It is to be determined if this heat pump can be used to meet the cooling needs of a room by absorbing heat from it.

Assumptions The COP of the heat pump remains constant whether heat is absorbed from the outdoor air or room air.

Analysis The COP of the heat pump is given to be 3.4. Then the COP of the air-conditioning system becomes

$$\text{COP}_{\text{air-cond}} = \text{COP}_{\text{heat pump}} - 1 = 3.4 - 1 = 2.4$$

Then the rate of cooling (heat absorption from the air) becomes

$$\dot{Q}_{\text{cooling}} = \text{COP}_{\text{air-cond}} \dot{W}_{\text{in}} = (3.4)(6 \text{ kW}) = 20.4 \text{ kW} = 51,840 \text{ kJ/h}$$

since 1 kW = 3600 kJ/h. We conclude that this heat pump **can meet** the cooling needs of the room since its cooling rate is greater than the rate of heat gain of the room.

11-106 A heat pump that operates on the ideal vapor-compression cycle with refrigerant-134a as the working fluid is used to heat a house. The rate of heat supply to the house, the volume flow rate of the refrigerant at the compressor inlet, and the COP of this heat pump are to be determined.

Assumptions 1 Steady operating conditions exist. 2 Kinetic and potential energy changes are negligible.

Analysis (a) In an ideal vapor-compression refrigeration cycle, the compression process is isentropic, the refrigerant enters the compressor as a saturated vapor at the evaporator pressure, and leaves the condenser as saturated liquid at the condenser pressure. From the refrigerant tables (Tables A-12 and A-13),

$$P_1 = 320 \text{ kPa} \left. \begin{array}{l} h_1 = h_g @ 320 \text{ kPa} = 251.93 \text{ kJ/kg} \\ s_1 = s_g @ 320 \text{ kPa} = 0.93026 \text{ kJ/kg} \cdot \text{K} \\ \nu_1 = \nu_g @ 320 \text{ kPa} = 0.063681 \text{ m}^3/\text{kg} \end{array} \right\} \text{sat. vapor}$$

$$P_2 = 1.4 \text{ MPa} \left. \begin{array}{l} h_2 = 282.60 \text{ kJ/kg} \\ s_2 = s_1 \end{array} \right\}$$

$$P_3 = 1.4 \text{ MPa} \left. \begin{array}{l} h_3 = h_f @ 1.4 \text{ MPa} = 127.25 \text{ kJ/kg} \\ \text{sat. liquid} \end{array} \right\}$$

$$h_4 \cong h_3 = 127.25 \text{ kJ/kg} \text{ (throttling)}$$

The rate of heat supply to the house is determined from

$$\dot{Q}_H = \dot{m}(h_2 - h_3) = (0.25 \text{ kg/s})(282.60 - 127.25) \text{ kJ/kg} = \mathbf{38.8 \text{ kW}}$$

(b) The volume flow rate of the refrigerant at the compressor inlet is

$$\dot{V}_1 = \dot{m}\nu_1 = (0.25 \text{ kg/s})(0.063681 \text{ m}^3/\text{kg}) = \mathbf{0.0159 \text{ m}^3/\text{s}}$$

(c) The COP of this heat pump is determined from

$$\text{COP}_R = \frac{q_L}{w_{\text{in}}} = \frac{h_2 - h_3}{h_2 - h_1} = \frac{282.60 - 127.25}{282.60 - 251.93} = \mathbf{5.07}$$

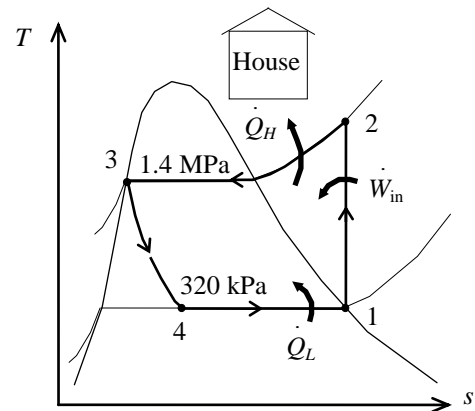

11-107 A large refrigeration plant that operates on the ideal vapor-compression cycle with refrigerant-134a as the working fluid is considered. The mass flow rate of the refrigerant, the power input to the compressor, and the mass flow rate of the cooling water are to be determined.

Assumptions 1 Steady operating conditions exist. 2 Kinetic and potential energy changes are negligible.

Analysis (a) In an ideal vapor-compression refrigeration cycle, the compression process is isentropic, the refrigerant enters the compressor as a saturated vapor at the evaporator pressure, and leaves the condenser as saturated liquid at the condenser pressure. From the refrigerant tables (Tables A-12 and A-13),

$$\left. \begin{array}{l} P_1 = 120 \text{ kPa} \\ \text{sat. vapor} \end{array} \right\} \begin{array}{l} h_1 = h_g @ 120 \text{ kPa} = 236.99 \text{ kJ/kg} \\ s_1 = s_g @ 120 \text{ kPa} = 0.94789 \text{ kJ/kg} \cdot \text{K} \end{array}$$

$$\left. \begin{array}{l} P_2 = 0.7 \text{ MPa} \\ s_2 = s_1 \end{array} \right\} \begin{array}{l} h_2 = 273.52 \text{ kJ/kg} \quad (T_2 = 34.95^\circ\text{C}) \end{array}$$

$$\left. \begin{array}{l} P_3 = 0.7 \text{ MPa} \\ \text{sat. liquid} \end{array} \right\} h_3 = h_f @ 0.7 \text{ MPa} = 88.82 \text{ kJ/kg}$$

$$h_4 \cong h_3 = 88.82 \text{ kJ/kg} \quad (\text{throttling})$$

The mass flow rate of the refrigerant is determined from

$$\dot{m} = \frac{\dot{Q}_L}{h_1 - h_4} = \frac{100 \text{ kJ/s}}{(236.99 - 88.82) \text{ kJ/kg}} = \mathbf{0.6749 \text{ kg/s}}$$

(b) The power input to the compressor is

$$\dot{W}_{\text{in}} = \dot{m}(h_2 - h_1) = (0.6749 \text{ kg/s})(273.52 - 236.99) \text{ kJ/kg} = \mathbf{24.7 \text{ kW}}$$

(c) The mass flow rate of the cooling water is determined from

$$\dot{Q}_H = \dot{m}(h_2 - h_3) = (0.6749 \text{ kg/s})(273.52 - 88.82) \text{ kJ/kg} = 124.7 \text{ kW}$$

$$\dot{m}_{\text{cooling}} = \frac{\dot{Q}_H}{(c_p \Delta T)_{\text{water}}} = \frac{124.7 \text{ kJ/s}}{(4.18 \text{ kJ/kg} \cdot ^\circ\text{C})(8^\circ\text{C})} = \mathbf{3.73 \text{ kg/s}}$$

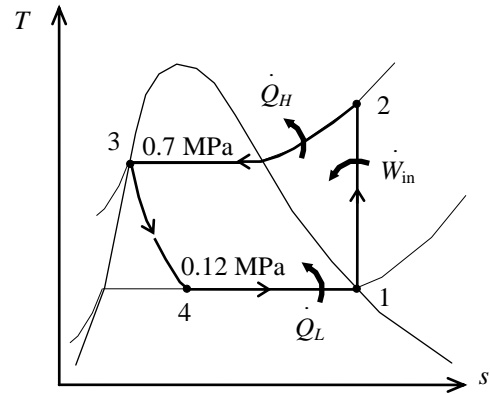



11-108 Problem 11-107 is reconsidered. The effect of evaporator pressure on the COP and the power input is to be investigated.

Analysis The problem is solved using EES, and the solution is given below.

"Input Data"

```
"P[1]=120 [kPa]"
P[2] = 700 [kPa]
Q_dot_in= 100 [kW]
DELTAT_cw = 8 [C]
C_P_cw = 4.18 [kJ/kg-K]
Fluid$='R134a'
Eta_c=1.0 "Compressor isentropic efficiency"
```

"Compressor"

```
h[1]=enthalpy(Fluid$,P=P[1],x=1) "properties for state 1"
s[1]=entropy(Fluid$,P=P[1],x=1)
T[1]=temperature(Fluid$,h=h[1],P=P[1])
h2s=enthalpy(Fluid$,P=P[2],s=s[1]) "Identifies state 2s as isentropic"
h[1]+Wcs=h2s "energy balance on isentropic compressor"
Wc=Wcs/Eta_c "definition of compressor isentropic efficiency"
h[1]+Wc=h[2] "energy balance on real compressor-assumed adiabatic"
s[2]=entropy(Fluid$,h=h[2],P=P[2]) "properties for state 2"
{h[2]=enthalpy(Fluid$,P=P[2],T=T[2]) }
T[2]=temperature(Fluid$,h=h[2],P=P[2])
W_dot_c=m_dot*Wc
```

"Condenser"

```
P[3] = P[2]
h[3]=enthalpy(Fluid$,P=P[3],x=0) "properties for state 3"
s[3]=entropy(Fluid$,P=P[3],x=0)
h[2]=Qout+h[3] "energy balance on condenser"
Q_dot_out=m_dot*Qout
```

"Throttle Valve"

```
h[4]=h[3] "energy balance on throttle - isenthalpic"
x[4]=quality(Fluid$,h=h[4],P=P[4]) "properties for state 4"
s[4]=entropy(Fluid$,h=h[4],P=P[4])
T[4]=temperature(Fluid$,h=h[4],P=P[4])
```

"Evaporator"

```
P[4]= P[1]
Q_in + h[4]=h[1] "energy balance on evaporator"
Q_dot_in=m_dot*Q_in
COP=Q_dot_in/W_dot_c "definition of COP"
COP_plot = COP
W_dot_in = W_dot_c
m_dot_cw*C_P_cw*DELTAT_cw = Q_dot_out
```

P_1 [kPa]	COP	\dot{W}_C [kW]
120	4.056	24.65
150	4.743	21.08
180	5.475	18.26
210	6.271	15.95
240	7.147	13.99
270	8.127	12.31
300	9.236	10.83
330	10.51	9.516
360	11.99	8.339
390	13.75	7.274

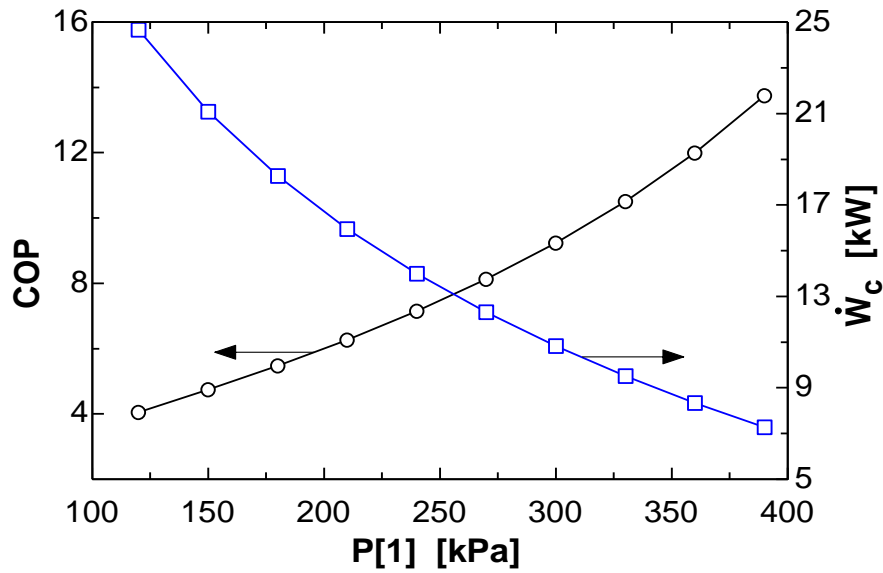

11-109 A large refrigeration plant operates on the vapor-compression cycle with refrigerant-134a as the working fluid. The mass flow rate of the refrigerant, the power input to the compressor, the mass flow rate of the cooling water, and the rate of exergy destruction associated with the compression process are to be determined.

Assumptions 1 Steady operating conditions exist. 2 Kinetic and potential energy changes are negligible.

Analysis (a) The refrigerant enters the compressor as a saturated vapor at the evaporator pressure, and leaves the condenser as saturated liquid at the condenser pressure. From the refrigerant tables (Tables A-12 and A-13),

$$\left. \begin{array}{l} P_1 = 120 \text{ kPa} \\ \text{sat. vapor} \end{array} \right\} \begin{array}{l} h_1 = h_g @ 120 \text{ kPa} = 236.99 \text{ kJ/kg} \\ s_1 = s_g @ 120 \text{ kPa} = 0.94789 \text{ kJ/kg} \cdot \text{K} \end{array}$$

$$\left. \begin{array}{l} P_2 = 0.7 \text{ MPa} \\ s_2 = s_1 \end{array} \right\} \begin{array}{l} h_{2s} = 273.52 \text{ kJ/kg} \quad (T_2 = 34.95^\circ\text{C}) \\ \end{array}$$

$$\left. \begin{array}{l} P_3 = 0.7 \text{ MPa} \\ \text{sat. liquid} \end{array} \right\} h_3 = h_f @ 0.7 \text{ MPa} = 88.82 \text{ kJ/kg}$$

$$h_4 \cong h_3 = 88.82 \text{ kJ/kg} \quad (\text{throttling})$$

The mass flow rate of the refrigerant is determined from

$$\dot{m} = \frac{\dot{Q}_L}{h_1 - h_4} = \frac{100 \text{ kJ/s}}{(236.99 - 88.82) \text{ kJ/kg}} = \mathbf{0.6749 \text{ kg/s}}$$

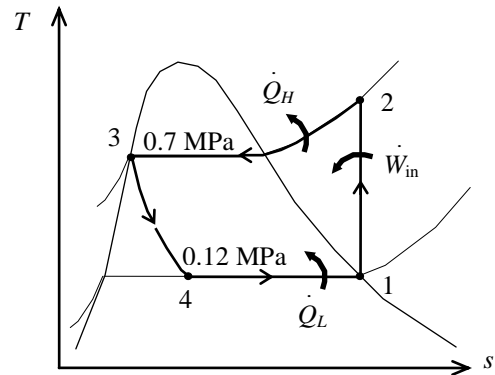

(b) The actual enthalpy at the compressor exit is

$$\eta_C = \frac{h_{2s} - h_1}{h_2 - h_1} \longrightarrow h_2 = h_1 + (h_{2s} - h_1) / \eta_C = 236.99 + (273.52 - 236.99) / (0.75) = 285.70 \text{ kJ/kg}$$

Thus,

$$\dot{W}_{\text{in}} = \dot{m}(h_2 - h_1) = (0.6749 \text{ kg/s})(285.70 - 236.99) \text{ kJ/kg} = \mathbf{32.9 \text{ kW}}$$

(c) The mass flow rate of the cooling water is determined from

$$\dot{Q}_H = \dot{m}(h_2 - h_3) = (0.6749 \text{ kg/s})(285.70 - 88.82) \text{ kJ/kg} = 132.9 \text{ kW}$$

and

$$\dot{m}_{\text{cooling}} = \frac{\dot{Q}_H}{(c_p \Delta T)_{\text{water}}} = \frac{132.9 \text{ kJ/s}}{(4.18 \text{ kJ/kg} \cdot ^\circ\text{C})(8^\circ\text{C})} = \mathbf{3.97 \text{ kg/s}}$$

The exergy destruction associated with this adiabatic compression process is determined from

$$\dot{X}_{\text{destroyed}} = T_0 \dot{S}_{\text{gen}} = T_0 \dot{m}(s_2 - s_1)$$

where

$$\left. \begin{array}{l} P_2 = 0.7 \text{ MPa} \\ h_2 = 285.70 \text{ kJ/kg} \end{array} \right\} s_2 = 0.98665 \text{ kJ/kg} \cdot \text{K}$$

Thus,

$$\dot{X}_{\text{destroyed}} = (298 \text{ K})(0.6749 \text{ kg/s})(0.98665 - 0.94789) \text{ kJ/kg} \cdot \text{K} = \mathbf{7.80 \text{ kW}}$$

11-110 An ideal vapor-compression refrigeration cycle with refrigerant-22 as the working fluid is considered. The evaporator is located inside the air handler of building. The hardware and the T-s diagram for this heat pump application are to be sketched. The COP of the unit and the ratio of volume flow rate of air entering the air handler to mass flow rate of R-22 through the air handler are to be determined.

Assumptions 1 Steady operating conditions exist. 2 Kinetic and potential energy changes are negligible.

Analysis (a) In an ideal vapor-compression refrigeration cycle, the compression process is isentropic, the refrigerant enters the compressor as a saturated vapor at the evaporator pressure, and leaves the condenser as saturated liquid at the condenser pressure. From the refrigerant-22 data from the problem statement,

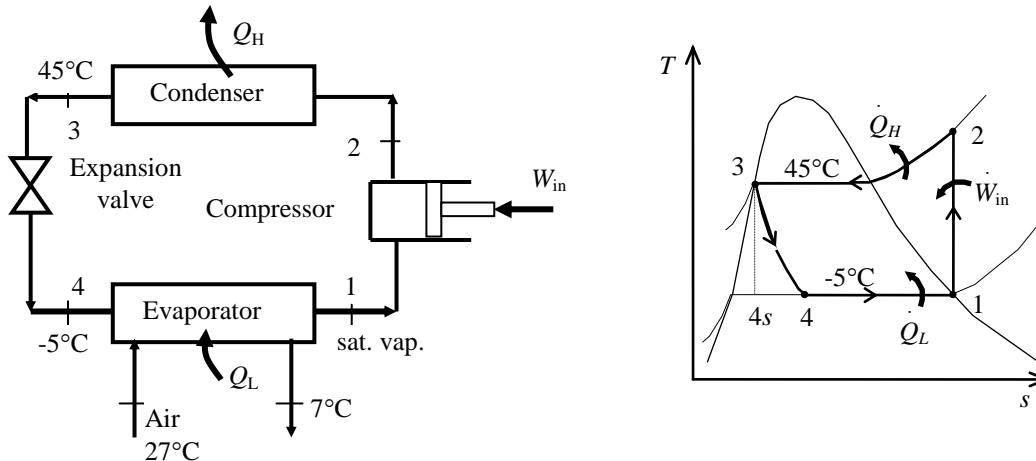

$$\left. \begin{array}{l} T_1 = -5^\circ\text{C} \\ \text{sat. vapor} \end{array} \right\} \begin{array}{l} h_1 = h_g @ -5^\circ\text{C} = 248.1 \text{ kJ/kg} \\ s_1 = s_g @ -5^\circ\text{C} = 0.9344 \text{ kJ/kg}\cdot\text{K} \end{array}$$

$$\left. \begin{array}{l} P_2 = 1728 \text{ kPa} \\ s_2 = s_1 \end{array} \right\} h_2 = 283.7 \text{ kJ/kg}$$

$$\left. \begin{array}{l} P_3 = 1728 \text{ kPa} \\ \text{sat. liquid} \end{array} \right\} h_3 = h_f @ 1728 \text{ kPa} = 101 \text{ kJ/kg}$$

$$h_4 \cong h_3 = 101 \text{ kJ/kg} \quad (\text{throttling})$$

(b) The COP of the refrigerator is determined from its definition,

$$\text{COP}_R = \frac{q_L}{w_{\text{in}}} = \frac{h_1 - h_4}{h_2 - h_1} = \frac{248.1 - 101}{283.7 - 248.1} = \mathbf{4.13}$$

(c) An energy balance on the evaporator gives

$$\dot{Q}_L = \dot{m}_R (h_1 - h_4) = \dot{m}_a c_p \Delta T = \frac{\dot{V}_a}{\nu_a} c_p \Delta T$$

Rearranging, we obtain the ratio of volume flow rate of air entering the air handler to mass flow rate of R-22 through the air handler

$$\begin{aligned} \frac{\dot{V}_a}{\dot{m}_R} &= \frac{h_1 - h_4}{(1/\nu)c_p \Delta T} = \frac{(248.1 - 101) \text{ kJ/kg}}{(1/0.8323 \text{ m}^3/\text{kg})(1.005 \text{ kJ/kg}\cdot\text{K})(20 \text{ K})} \\ &= 6.091 \text{ (m}^3 \text{ air/s)/(kg R22/s)} \\ &= \mathbf{365 \text{ (m}^3 \text{ air/min)/(kg R22/s)}} \end{aligned}$$

Note that the specific volume of air is obtained from ideal gas equation taking the pressure of air to be 100 kPa (given) and using the average temperature of air ($17^\circ\text{C} = 290 \text{ K}$) to be $0.8323 \text{ m}^3/\text{kg}$.

11-111 An air-conditioner with refrigerant-134a as the refrigerant is considered. The temperature of the refrigerant at the compressor exit, the rate of heat generated by the people in the room, the COP of the air-conditioner, and the minimum volume flow rate of the refrigerant at the compressor inlet are to be determined.

Assumptions 1 Steady operating conditions exist. 2 Kinetic and potential energy changes are negligible.

Analysis (a) From the refrigerant-134a tables (Tables A-11 through A-13)

$$P_1 = 500 \text{ kPa} \left\{ \begin{array}{l} h_1 = 259.36 \text{ kJ/kg} \\ v_1 = 0.04117 \text{ m}^3/\text{kg} \\ s_1 = 0.9242 \text{ kJ/kg} \end{array} \right.$$

$$P_2 = 1200 \text{ kPa} \left\{ \begin{array}{l} h_{2s} = 277.45 \\ s_2 = s_1 \end{array} \right.$$

$$h_3 = h_{f@1200\text{kPa}} = 117.79 \text{ kJ/kg}$$

$$h_4 = h_3 = 117.79 \text{ kJ/kg}$$

$$\eta_C = \frac{h_{2s} - h_1}{h_2 - h_1}$$

$$0.75 = \frac{277.45 - 259.36}{h_2 - 259.36} \rightarrow h_2 = 283.48 \text{ kJ/kg}$$

$$P_2 = 1200 \text{ kPa} \left\{ \begin{array}{l} h_2 = 283.48 \text{ kJ/kg} \\ T_2 = \mathbf{54.5^\circ\text{C}} \end{array} \right.$$

(b) The mass flow rate of the refrigerant is

$$\dot{m} = \frac{\dot{v}_1}{v_1} = \frac{(100 \text{ L/min}) \left(\frac{1 \text{ m}^3}{1000 \text{ L}} \right) \left(\frac{1 \text{ min}}{60 \text{ s}} \right)}{0.04117 \text{ m}^3/\text{kg}} = 0.04048 \text{ kg/s}$$

The refrigeration load is

$$\dot{Q}_L = \dot{m}(h_1 - h_4) = (0.04048 \text{ kg/s})(259.36 - 117.79) \text{ kJ/kg} = 5.731 \text{ kW}$$

which is the total heat removed from the room. Then, the rate of heat generated by the people in the room is determined from

$$\dot{Q}_{\text{people}} = \dot{Q}_L - \dot{Q}_{\text{heat}} - \dot{Q}_{\text{equip}} = (5.731 - 250/60 - 0.9) \text{ kW} = \mathbf{0.665 \text{ kW}}$$

(c) The power input and the COP are

$$\dot{W}_{\text{in}} = \dot{m}(h_2 - h_1) = (0.04048 \text{ kg/s})(283.48 - 259.36) \text{ kJ/kg} = 0.9764 \text{ kW}$$

$$\text{COP} = \frac{\dot{Q}_L}{\dot{W}_{\text{in}}} = \frac{5.731}{0.9764} = \mathbf{5.87}$$

(d) The reversible COP of the cycle is

$$\text{COP}_{\text{rev}} = \frac{1}{T_H / T_L - 1} = \frac{1}{(34 + 273) / (26 + 273) - 1} = 37.38$$

The corresponding minimum power input is

$$\dot{W}_{\text{in,min}} = \frac{\dot{Q}_L}{\text{COP}_{\text{rev}}} = \frac{5.731 \text{ kW}}{37.38} = 0.1533 \text{ kW}$$

The minimum mass and volume flow rates are

$$\dot{m}_{\text{min}} = \frac{\dot{W}_{\text{in,min}}}{h_2 - h_1} = \frac{0.1533 \text{ kW}}{(283.48 - 259.36) \text{ kJ/kg}} = 0.006358 \text{ kg/s}$$

$$\dot{v}_{1,\text{min}} = \dot{m}_{\text{min}} v_1 = (0.006358 \text{ kg/s})(0.04117 \text{ m}^3/\text{kg}) = (0.0002618 \text{ m}^3/\text{s}) = \mathbf{15.7 \text{ L/min}}$$

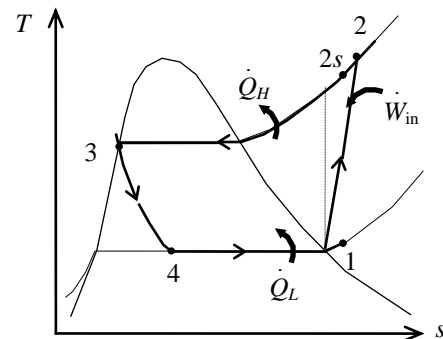
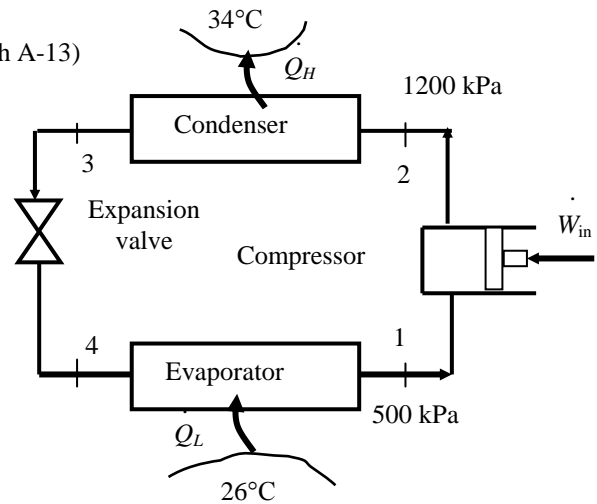

11-112 An air conditioner operates on the vapor-compression refrigeration cycle. The rate of cooling provided to the space, the COP, the isentropic efficiency and the exergetic efficiency of the compressor, the exergy destruction in each component of the cycle, the total exergy destruction, the minimum power input, and the second-law efficiency of the cycle are to be determined.

Assumptions 1 Steady operating conditions exist. 2 Kinetic and potential energy changes are negligible.

Analysis (a) The properties of R-134a are (Tables A-11 through A-13)

$$T_{\text{sat}@180\text{kPa}} = -12.7^\circ\text{C}$$

$$\left. \begin{array}{l} P_1 = 180 \text{ kPa} \\ T_1 = -12.7 + 2.7 = 10^\circ\text{C} \end{array} \right\} \begin{array}{l} h_1 = 245.15 \text{ kJ/kg} \\ s_1 = 0.9484 \text{ kJ/kg} \cdot \text{K} \end{array}$$

$$\left. \begin{array}{l} P_2 = 1200 \text{ kPa} \\ s_1 = s_1 \end{array} \right\} h_{2s} = 285.34 \text{ kJ/kg}$$

$$\left. \begin{array}{l} P_2 = 1200 \text{ kPa} \\ T_2 = 60^\circ\text{C} \end{array} \right\} \begin{array}{l} h_2 = 289.66 \text{ kJ/kg} \\ s_2 = 0.9615 \text{ kJ/kg} \cdot \text{K} \end{array}$$

$$T_{\text{sat}@1200\text{kPa}} = 46.3^\circ\text{C}$$

$$\left. \begin{array}{l} P_3 = 1200 \text{ kPa} \\ T_3 = 46.3 - 6.3 = 40^\circ\text{C} \end{array} \right\} \begin{array}{l} h_3 \cong h_{f@40^\circ\text{C}} = 108.27 \text{ kJ/kg} \\ s_3 \cong s_{f@40^\circ\text{C}} = 0.3949 \text{ kJ/kg} \cdot \text{K} \end{array}$$

$$h_4 = h_3 = 108.27 \text{ kJ/kg}$$

$$\left. \begin{array}{l} P_4 = 180 \text{ kPa} \\ h_4 = 108.26 \text{ kJ/kg} \end{array} \right\} s_4 = 0.4229 \text{ kJ/kg} \cdot \text{K}$$

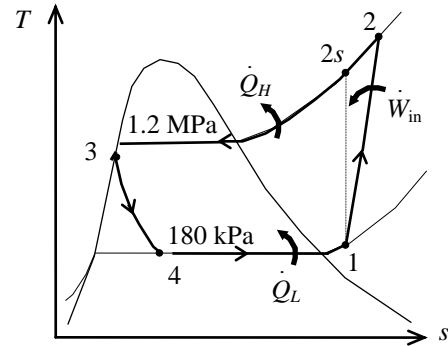

The cooling load and the COP are

$$\begin{aligned} \dot{Q}_L &= \dot{m}(h_1 - h_4) = (0.06 \text{ kg/s})(245.15 - 108.27) \text{ kJ/kg} = 8.213 \text{ kW} \\ &= (8.213 \text{ kW}) \left(\frac{3412 \text{ Btu/h}}{1 \text{ kW}} \right) = \mathbf{28,020 \text{ Btu/h}} \end{aligned}$$

$$\dot{Q}_H = \dot{m}(h_2 - h_3) = (0.06 \text{ kg/s})(289.66 - 108.27) \text{ kJ/kg} = 10.88 \text{ kW}$$

$$\dot{W}_{\text{in}} = \dot{m}(h_2 - h_1) = (0.06 \text{ kg/s})(289.66 - 245.15) \text{ kJ/kg} = 2.670 \text{ kW}$$

$$\text{COP} = \frac{\dot{Q}_L}{\dot{W}_{\text{in}}} = \frac{8.213 \text{ kW}}{2.670 \text{ kW}} = \mathbf{3.076}$$

(b) The isentropic efficiency of the compressor is

$$\eta_C = \frac{h_{2s} - h_1}{h_2 - h_1} = \frac{285.34 - 245.15}{289.66 - 245.15} = 0.903 = \mathbf{90.3\%}$$

The reversible power and the exergetic efficiency for the compressor are

$$\begin{aligned} \dot{W}_{\text{rev}} &= \dot{m}[(h_2 - h_1) - T_0(s_2 - s_1)] \\ &= (0.06 \text{ kg/s})[(289.66 - 245.15) \text{ kJ/kg} - (310 \text{ K})(0.9615 - 0.9484) \text{ kJ/kg} \cdot \text{K}] \\ &= 2.428 \text{ kW} \end{aligned}$$

$$\eta_{\text{ex,C}} = \frac{\dot{W}_{\text{rev}}}{\dot{W}_{\text{in}}} = \frac{2.428 \text{ kW}}{2.670 \text{ kW}} = 0.909 = \mathbf{90.9\%}$$

(c) The exergy destruction in each component of the cycle is determined as follows

Compressor:

$$\dot{S}_{\text{gen},1-2} = \dot{m}(s_2 - s_1) = (0.06 \text{ kg/s})(0.9615 - 0.9484) \text{ kJ/kg} \cdot \text{K} = 0.0007827 \text{ kW/K}$$

$$\dot{E}x_{\text{dest},1,2} = T_0 \dot{S}_{\text{gen},1,2} = (310 \text{ K})(0.0007827 \text{ kW/K}) = \mathbf{0.2426 \text{ kW}}$$

Condenser:

$$\dot{S}_{\text{gen},2-3} = \dot{m}(s_3 - s_2) + \frac{\dot{Q}_H}{T_H} = (0.06 \text{ kg/s})(0.3949 - 0.9615) \text{ kJ/kg} \cdot \text{K} + \frac{10.88 \text{ kW}}{310 \text{ K}} = 0.001114 \text{ kW/K}$$

$$\dot{E}x_{\text{dest},2,3} = T_0 \dot{S}_{\text{gen},2,3} = (310 \text{ K})(0.001114 \text{ kJ/kg} \cdot \text{K}) = \mathbf{0.3452 \text{ kW}}$$

Expansion valve:

$$\dot{S}_{\text{gen},3-4} = \dot{m}(s_4 - s_3) = (0.06 \text{ kg/s})(0.4229 - 0.3949) \text{ kJ/kg} \cdot \text{K} = 0.001678 \text{ kW/K}$$

$$\dot{E}x_{\text{dest},3,4} = T_0 \dot{S}_{\text{gen},3,4} = (310 \text{ K})(0.001678 \text{ kJ/kg} \cdot \text{K}) = \mathbf{0.5202 \text{ kJ/kg}}$$

Evaporator:

$$\dot{S}_{\text{gen},4-1} = \dot{m}(s_1 - s_4) - \frac{\dot{Q}_L}{T_L} = (0.06 \text{ kg/s})(0.9484 - 0.4229) \text{ kJ/kg} \cdot \text{K} - \frac{8.213 \text{ kW}}{294 \text{ K}} = 0.003597 \text{ kW/K}$$

$$\dot{E}x_{\text{dest},4,1} = T_0 \dot{S}_{\text{gen},4,1} = (310 \text{ K})(0.003597 \text{ kJ/kg} \cdot \text{K}) = \mathbf{1.115 \text{ kW}}$$

The total exergy destruction can be determined by adding exergy destructions in each component:

$$\begin{aligned} \dot{E}x_{\text{dest},\text{total}} &= \dot{E}x_{\text{dest},1,2} + \dot{E}x_{\text{dest},2,3} + \dot{E}x_{\text{dest},3,4} + \dot{E}x_{\text{dest},4,1} \\ &= 0.2426 + 0.3452 + 0.5202 + 1.115 \\ &= \mathbf{2.223 \text{ kW}} \end{aligned}$$

(d) The exergy of the heat transferred from the low-temperature medium is

$$\dot{E}x_{\dot{Q}_L} = -\dot{Q}_L \left(1 - \frac{T_0}{T_L} \right) = -(8.213 \text{ kW}) \left(1 - \frac{310}{294} \right) = 0.4470 \text{ kW}$$

This is the minimum power input to the cycle:

$$\dot{W}_{\text{in},\text{min}} = \dot{E}x_{\dot{Q}_L} = \mathbf{0.4470 \text{ kW}}$$

The second-law efficiency of the cycle is

$$\eta_{\text{II}} = \frac{\dot{W}_{\text{in},\text{min}}}{\dot{W}_{\text{in}}} = \frac{0.4470}{2.670} = 0.167 = \mathbf{16.7\%}$$

The total exergy destruction in the cycle can also be determined from

$$\dot{E}x_{\text{dest},\text{total}} = \dot{W}_{\text{in}} - \dot{E}x_{\dot{Q}_L} = 2.670 - 0.4470 = 2.223 \text{ kW}$$

The result is the same as expected.

11-113 A two-stage compression refrigeration system using refrigerant-134a as the working fluid is considered. The fraction of the refrigerant that evaporates as it is throttled to the flash chamber, the amount of heat removed from the refrigerated space, the compressor work, and the COP are to be determined.

Assumptions 1 Steady operating conditions exist. 2 Kinetic and potential energy changes are negligible. 3 The flashing chamber is adiabatic.

Analysis (a) The enthalpies of the refrigerant at several states are determined from the refrigerant tables to be (Tables A-11, A-12, and A-13)

$$h_1 = 236.99 \text{ kJ/kg}, \quad h_2 = 266.29 \text{ kJ/kg}$$

$$h_3 = 259.36 \text{ kJ/kg},$$

$$h_5 = 127.25 \text{ kJ/kg}, \quad h_6 = 127.25 \text{ kJ/kg}$$

$$h_7 = 73.32 \text{ kJ/kg}, \quad h_8 = 73.32 \text{ kJ/kg}$$

The fraction of the refrigerant that evaporates as it is throttled to the flash chamber is simply the quality at state 6,

$$x_6 = \frac{h_6 - h_f}{h_{fg}} = \frac{127.25 - 73.32}{186.04} = \mathbf{0.2899}$$

(b) The enthalpy at state 9 is determined from an energy balance on the mixing chamber:

$$\dot{E}_{\text{in}} - \dot{E}_{\text{out}} = \Delta \dot{E}_{\text{system}} \stackrel{\phi=0(\text{steady})}{=} 0 \rightarrow \dot{E}_{\text{in}} = \dot{E}_{\text{out}}$$

$$\sum \dot{m}_e h_e = \sum \dot{m}_i h_i$$

$$(1)h_9 = x_6 h_3 + (1 - x_6)h_2$$

$$h_9 = (0.2899)(259.36) + (1 - 0.2899)(266.29) = 264.28 \text{ kJ/kg}$$

$$\left. \begin{array}{l} P_9 = 0.5 \text{ MPa} \\ h_9 = 264.28 \text{ kJ/kg} \end{array} \right\} s_9 = 0.94108 \text{ kJ/kg} \cdot \text{K}$$

Also,

$$\left. \begin{array}{l} P_4 = 1.4 \text{ MPa} \\ s_4 = s_9 = 0.94108 \text{ kJ/kg} \cdot \text{K} \end{array} \right\} h_4 = 286.19 \text{ kJ/kg}$$

Then the amount of heat removed from the refrigerated space and the compressor work input per unit mass of refrigerant flowing through the condenser are

$$q_L = (1 - x_6)(h_1 - h_8) = (1 - 0.2899)(236.99 - 73.32) \text{ kJ/kg} = \mathbf{116.2 \text{ kJ/kg}}$$

$$\begin{aligned} w_{\text{in}} &= w_{\text{compI, in}} + w_{\text{compII, in}} = (1 - x_6)(h_2 - h_1) + (1)(h_4 - h_9) \\ &= (1 - 0.2899)(266.29 - 236.99) \text{ kJ/kg} + (1)(286.19 - 264.28) \text{ kJ/kg} \\ &= \mathbf{42.72 \text{ kJ/kg}} \end{aligned}$$

(c) The coefficient of performance is determined from

$$\text{COP}_R = \frac{q_L}{w_{\text{in}}} = \frac{116.2 \text{ kJ/kg}}{42.72 \text{ kJ/kg}} = \mathbf{2.72}$$

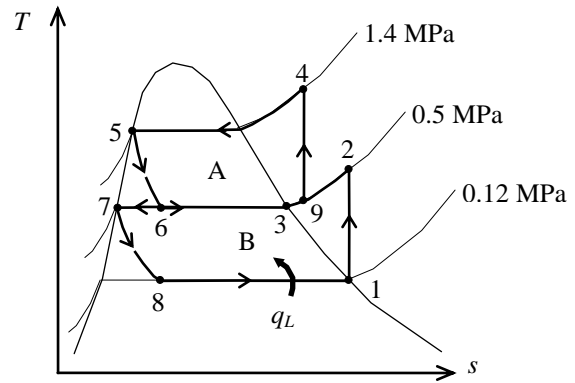

11-114E A two-evaporator compression refrigeration cycle with refrigerant-134a as the working fluid is considered. The cooling load of both evaporators per unit of flow through the compressor and the COP of the system are to be determined.

Assumptions 1 Steady operating conditions exist. **2** Kinetic and potential energy changes are negligible.

Analysis From the refrigerant tables (Tables A-11E, A-12E, and A-13E),

$$\left. \begin{array}{l} P_3 = 160 \text{ psia} \\ \text{sat. liquid} \end{array} \right\} h_3 = h_f @ 160 \text{ psia} = 48.527 \text{ Btu/lbm}$$

$$h_4 = h_6 \cong h_3 = 48.527 \text{ Btu/lbm} \quad (\text{throttling})$$

$$\left. \begin{array}{l} T_5 = 30^\circ\text{F} \\ \text{sat. vapor} \end{array} \right\} h_5 = h_g @ 30^\circ\text{F} = 107.42 \text{ Btu/lbm}$$

$$\left. \begin{array}{l} T_7 = -29.5^\circ\text{F} \\ \text{sat. vapor} \end{array} \right\} h_7 = h_g @ -29.5^\circ\text{F} = 98.69 \text{ Btu/lbm}$$

For a unit mass flowing through the compressor, the fraction of mass flowing through Evaporator II is denoted by x and that through Evaporator I is y ($y = 1 - x$). From the cooling loads specification,

$$\begin{aligned} \dot{Q}_{L, \text{evap1}} &= 2\dot{Q}_{L, \text{evap2}} \\ x(h_5 - h_4) &= 2y(h_7 - h_6) \end{aligned}$$

where $x = 1 - y$

Combining these results and solving for y gives

$$y = \frac{h_5 - h_4}{2(h_7 - h_6) + (h_5 - h_4)} = \frac{107.42 - 48.527}{2(98.69 - 48.527) + (107.42 - 48.527)} = 0.3699$$

Then, $x = 1 - y = 1 - 0.3699 = 0.6301$

Applying an energy balance to the point in the system where the two evaporator streams are recombined gives

$$xh_5 + yh_7 = h_1 \longrightarrow h_1 = \frac{xh_5 + yh_7}{1} = \frac{(0.6301)(107.42) + (0.3699)(98.69)}{1} = 104.19 \text{ Btu/lbm}$$

Then,

$$\left. \begin{array}{l} P_1 = P_{\text{sat}} @ -29.5^\circ\text{F} \cong 10 \text{ psia} \\ h_1 = 104.19 \text{ Btu/lbm} \end{array} \right\} s_1 = 0.2418 \text{ Btu/lbm} \cdot \text{R}$$

$$\left. \begin{array}{l} P_2 = 160 \text{ psia} \\ s_2 = s_1 \end{array} \right\} h_2 = 131.15 \text{ Btu/lbm}$$

The cooling load of both evaporators per unit mass through the compressor is

$$\begin{aligned} q_L &= x(h_5 - h_4) + y(h_7 - h_6) \\ &= (0.6301)(107.42 - 48.527) \text{ Btu/lbm} + (0.3699)(98.69 - 48.527) \text{ Btu/lbm} \\ &= \mathbf{55.66 \text{ Btu/lbm}} \end{aligned}$$

The work input to the compressor is

$$w_{\text{in}} = h_2 - h_1 = (131.15 - 104.19) \text{ Btu/lbm} = 26.96 \text{ Btu/lbm}$$

The COP of this refrigeration system is determined from its definition,

$$\text{COP}_R = \frac{q_L}{w_{\text{in}}} = \frac{55.66 \text{ Btu/lbm}}{26.96 \text{ Btu/lbm}} = \mathbf{2.07}$$

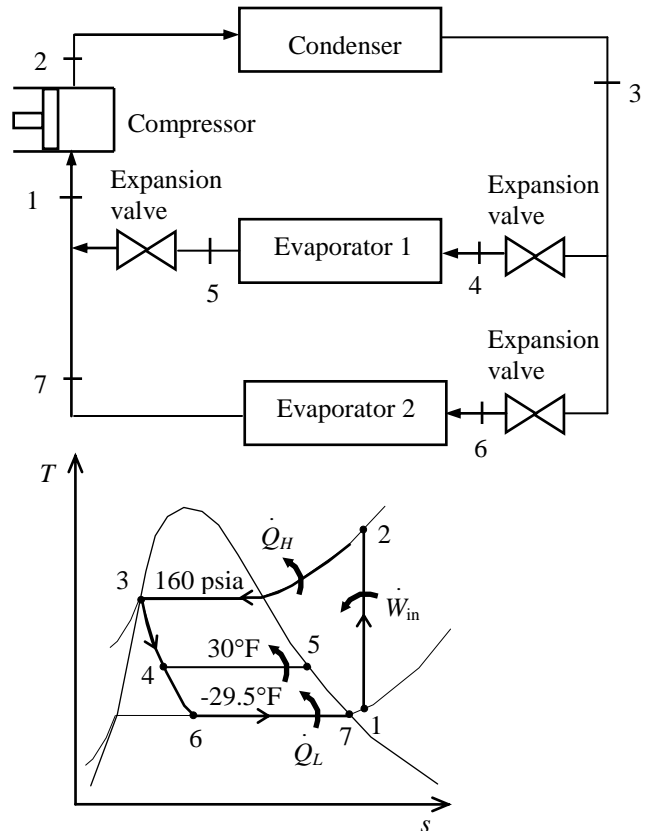

11-115E A two-evaporator compression refrigeration cycle with refrigerant-134a as the working fluid is considered. The process with the greatest exergy destruction is to be determined.

Assumptions 1 Steady operating conditions exist. 2 Kinetic and potential energy changes are negligible.

Analysis From Prob. 11-114E and the refrigerant tables (Tables A-11E, A-12E, and A-13E),

$$\begin{aligned} s_1 &= s_2 = 0.2418 \text{ Btu/lbm} \cdot \text{R} \\ s_3 &= 0.09776 \text{ Btu/lbm} \cdot \text{R} \\ s_4 &= 0.1024 \text{ Btu/lbm} \cdot \text{R} \\ s_5 &= 0.2226 \text{ Btu/lbm} \cdot \text{R} \\ s_6 &= 0.1129 \text{ Btu/lbm} \cdot \text{R} \\ s_7 &= 0.2295 \text{ Btu/lbm} \cdot \text{R} \\ x &= 0.6301 \\ y &= 1 - x = 0.3699 \\ q_{L,45} &= h_5 - h_4 = 58.89 \text{ Btu/lbm} \\ q_{L,67} &= h_7 - h_6 = 50.16 \text{ Btu/lbm} \\ q_H &= 82.62 \text{ Btu/lbm} \end{aligned}$$

The exergy destruction during a process of a stream from an inlet state to exit state is given by

$$x_{\text{dest}} = T_0 s_{\text{gen}} = T_0 \left(s_e - s_i - \frac{q_{\text{in}}}{T_{\text{source}}} + \frac{q_{\text{out}}}{T_{\text{sink}}} \right)$$

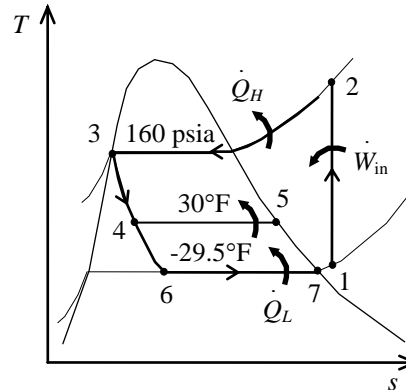

Application of this equation for each process of the cycle gives the exergy destructions per unit mass flowing through the compressor:

$$x_{\text{destroyed},23} = T_0 \left(s_3 - s_2 + \frac{q_H}{T_H} \right) = (540 \text{ R}) \left(0.09776 - 0.2418 + \frac{82.62 \text{ Btu/lbm}}{540 \text{ R}} \right) = 4.82 \text{ Btu/lbm}$$

$$\begin{aligned} x_{\text{destroyed},346} &= T_0 (xs_4 + ys_6 - s_3) \\ &= (540 \text{ R})(0.6301 \times 0.1024 + 0.3699 \times 0.1129 - 0.09776) \text{ Btu/lbm} \cdot \text{R} \\ &= 4.60 \text{ Btu/lbm} \end{aligned}$$

$$\begin{aligned} x_{\text{destroyed},45} &= xT_0 \left(s_5 - s_4 - \frac{q_{L,45}}{T_L} \right) \\ &= (0.6301)(540 \text{ R}) \left(0.2226 - 0.1024 - \frac{58.89 \text{ Btu/lbm}}{500 \text{ R}} \right) \\ &= 0.84 \text{ Btu/lbm} \end{aligned}$$

$$\begin{aligned} x_{\text{destroyed},67} &= yT_0 \left(s_7 - s_6 - \frac{q_{L,67}}{T_L} \right) \\ &= (0.3699)(540 \text{ R}) \left(0.2295 - 0.1129 - \frac{50.16 \text{ Btu/lbm}}{445 \text{ R}} \right) \\ &= 0.77 \text{ Btu/lbm} \end{aligned}$$

$$\begin{aligned} \dot{X}_{\text{destroyed,mixing}} &= T_0 (s_1 - xs_5 - ys_7) \\ &= (540 \text{ R}) [0.2418 - (0.6301)(0.2226) - (0.3699)(0.2295)] \\ &= \mathbf{9.00 \text{ Btu/lbm}} \end{aligned}$$

For isentropic processes, the exergy destruction is zero:

$$\dot{X}_{\text{destroyed},12} = 0$$

The greatest exergy destruction occurs during the mixing process. Note that heat is absorbed in evaporator 2 from a reservoir at -15°F (445 R), in evaporator 1 from a reservoir at 40°F (500 R), and rejected to a reservoir at 80°F (540 R), which is also taken as the dead state temperature.

11-116 A two-stage compression refrigeration system with a separation unit is considered. The rate of cooling and the power requirement are to be determined.

Assumptions 1 Steady operating conditions exist. 2 Kinetic and potential energy changes are negligible.

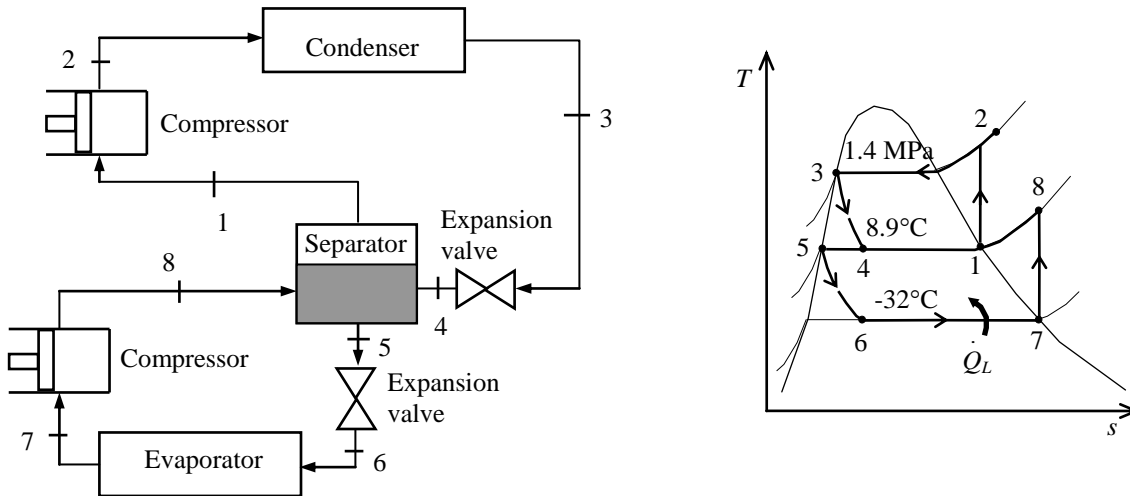

Analysis From the refrigerant tables (Tables A-11, A-12, and A-13),

$$\left. \begin{array}{l} T_1 = 8.9^\circ\text{C} \\ \text{sat. vapor} \end{array} \right\} \begin{array}{l} h_1 = h_g @ 8.9^\circ\text{C} = 255.60 \text{ kJ/kg} \\ s_1 = s_g @ 8.9^\circ\text{C} = 0.92711 \text{ kJ/kg}\cdot\text{K} \end{array}$$

$$\left. \begin{array}{l} P_2 = 1400 \text{ kPa} \\ s_2 = s_1 \end{array} \right\} h_2 = 281.56 \text{ kJ/kg}$$

$$\left. \begin{array}{l} P_3 = 1400 \text{ kPa} \\ \text{sat. liquid} \end{array} \right\} h_3 = h_f @ 1400 \text{ kPa} = 127.25 \text{ kJ/kg}$$

$$h_4 \cong h_3 = 127.25 \text{ kJ/kg} \quad (\text{throttling})$$

$$\left. \begin{array}{l} T_5 = 8.9^\circ\text{C} \\ \text{sat. liquid} \end{array} \right\} h_5 = h_f @ 8.9^\circ\text{C} = 63.91 \text{ kJ/kg}$$

$$h_6 \cong h_5 = 63.91 \text{ kJ/kg} \quad (\text{throttling})$$

$$\left. \begin{array}{l} T_7 = -32^\circ\text{C} \\ \text{sat. vapor} \end{array} \right\} \begin{array}{l} h_7 = h_g @ -32^\circ\text{C} = 230.93 \text{ kJ/kg} \\ s_7 = s_g @ -32^\circ\text{C} = 0.95819 \text{ kJ/kg}\cdot\text{K} \end{array}$$

$$\left. \begin{array}{l} P_8 = P_{\text{sat}} @ 8.9^\circ\text{C} = 400 \text{ kPa} \\ s_8 = s_7 \end{array} \right\} h_8 = 264.51 \text{ kJ/kg}$$

An energy balance on the separator gives

$$\dot{m}_6(h_8 - h_5) = \dot{m}_2(h_1 - h_4) \longrightarrow \dot{m}_6 = \dot{m}_2 \frac{h_1 - h_4}{h_8 - h_5} = (2 \text{ kg/s}) \frac{255.60 - 127.25}{264.51 - 63.91} = 1.280 \text{ kg/s}$$

The rate of cooling produced by this system is then

$$\dot{Q}_L = \dot{m}_6(h_7 - h_6) = (1.280 \text{ kg/s})(230.93 - 63.91) \text{ kJ/kg} = \mathbf{213.7 \text{ kJ/s}}$$

The total power input to the compressors is

$$\begin{aligned} \dot{W}_{\text{in}} &= \dot{m}_6(h_8 - h_7) + \dot{m}_2(h_2 - h_1) \\ &= (1.280 \text{ kg/s})(264.51 - 230.93) \text{ kJ/kg} + (2 \text{ kg/s})(281.56 - 255.60) \text{ kJ/kg} \\ &= \mathbf{94.9 \text{ kW}} \end{aligned}$$

11-117 A two-stage vapor-compression refrigeration system with refrigerant-134a as the working fluid is considered. The process with the greatest exergy destruction is to be determined.

Assumptions 1 Steady operating conditions exist. 2 Kinetic and potential energy changes are negligible.

Analysis From Prob. 11-116 and the refrigerant tables (Tables A-11, A-12, and A-13),

$$s_1 = s_2 = 0.92711 \text{ kJ/kg} \cdot \text{K}$$

$$s_3 = 0.45325 \text{ kJ/kg} \cdot \text{K}$$

$$s_4 = 0.47207 \text{ kJ/kg} \cdot \text{K}$$

$$s_5 = 0.24752 \text{ kJ/kg} \cdot \text{K}$$

$$s_6 = 0.26564 \text{ kJ/kg} \cdot \text{K}$$

$$s_7 = s_8 = 0.95819 \text{ kJ/kg} \cdot \text{K}$$

$$\dot{m}_{\text{upper}} = 2 \text{ kg/s}$$

$$\dot{m}_{\text{lower}} = 1.280 \text{ kg/s}$$

$$q_L = h_7 - h_6 = 167.02 \text{ kJ/kg}$$

$$q_H = h_2 - h_3 = 154.31 \text{ kJ/kg}$$

$$T_L = -22 + 273 = 251 \text{ K}$$

$$T_H = T_0 = 20 + 273 = 293 \text{ K}$$

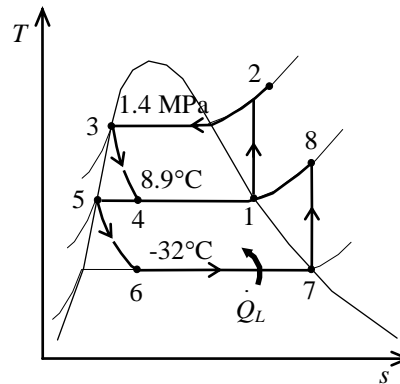

The exergy destruction during a process of a stream from an inlet state to exit state is given by

$$x_{\text{dest}} = T_0 s_{\text{gen}} = T_0 \left(s_e - s_i - \frac{q_{\text{in}}}{T_{\text{source}}} + \frac{q_{\text{out}}}{T_{\text{sink}}} \right)$$

Application of this equation for each process of the cycle gives

$$\begin{aligned} \dot{X}_{\text{destroyed},23} &= \dot{m}_{\text{upper}} T_0 \left(s_3 - s_2 + \frac{q_H}{T_H} \right) \\ &= (2 \text{ kg/s})(298 \text{ K}) \left(0.45325 - 0.92711 + \frac{154.31 \text{ kJ/kg}}{293 \text{ K}} \right) \\ &= \mathbf{30.94 \text{ kW}} \end{aligned}$$

$$\dot{X}_{\text{destroyed},34} = \dot{m}_{\text{upper}} T_0 (s_4 - s_3) = (2 \text{ kg/s})(293 \text{ K})(0.47207 - 0.45325) \text{ kJ/kg} \cdot \text{K} = 11.03 \text{ kW}$$

$$\dot{X}_{\text{destroyed},56} = \dot{m}_{\text{lower}} T_0 (s_6 - s_5) = (1.280 \text{ kg/s})(293 \text{ K})(0.26564 - 0.24752) \text{ kJ/kg} \cdot \text{K} = 6.793 \text{ kW}$$

$$\begin{aligned} \dot{X}_{\text{destroyed},67} &= \dot{m}_{\text{lower}} T_0 \left(s_7 - s_6 - \frac{q_L}{T_L} \right) \\ &= (1.280 \text{ kg/s})(293 \text{ K}) \left(0.95819 - 0.26564 - \frac{167.02 \text{ kJ/kg}}{251 \text{ K}} \right) \\ &= 10.18 \text{ kW} \end{aligned}$$

$$\begin{aligned} \dot{X}_{\text{destroyed,separator}} &= T_0 [\dot{m}_{\text{lower}} (s_5 - s_8) + \dot{m}_{\text{upper}} (s_1 - s_4)] \\ &= (293 \text{ K}) [(1.280 \text{ kg/s})(0.24752 - 0.95819) + (2 \text{ kg/s})(0.92711 - 0.47207)] \\ &= 0.197 \text{ kW} \end{aligned}$$

For isentropic processes, the exergy destruction is zero:

$$\dot{X}_{\text{destroyed},12} = 0$$

$$\dot{X}_{\text{destroyed},78} = 0$$

Note that heat is absorbed from a reservoir at -22°C (251 K) and rejected to the standard ambient air at 20°C (293 K), which is also taken as the dead state temperature. The greatest exergy destruction occurs during the condensation process.

11-118 An aircraft on the ground is to be cooled by a gas refrigeration cycle operating with air on an open cycle. The temperature of the air leaving the turbine is to be determined.

Assumptions **1** Steady operating conditions exist. **2** Air is an ideal gas with constant specific heats at room temperature. **3** Kinetic and potential energy changes are negligible.

Properties The specific heat ratio of air at room temperature is $k = 1.4$ (Table A-2).

Analysis Assuming the turbine to be isentropic, the air temperature at the turbine exit is determined from

$$T_4 = T_3 \left(\frac{P_4}{P_3} \right)^{(k-1)/k} = (343 \text{ K}) \left(\frac{100 \text{ kPa}}{250 \text{ kPa}} \right)^{0.4/1.4} = 264 \text{ K} = -9.0^\circ\text{C}$$

11-119 A regenerative gas refrigeration cycle with helium as the working fluid is considered. The temperature of the helium at the turbine inlet, the COP of the cycle, and the net power input required are to be determined.

Assumptions 1 Steady operating conditions exist. 2 Helium is an ideal gas with constant specific heats at room temperature. 3 Kinetic and potential energy changes are negligible.

Properties The properties of helium are $c_p = 5.1926 \text{ kJ/kg}\cdot\text{K}$ and $k = 1.667$ (Table A-2).

Analysis (a) The temperature of the helium at the turbine inlet is determined from an energy balance on the regenerator,

$$\begin{aligned}\dot{E}_{\text{in}} - \dot{E}_{\text{out}} &= \Delta\dot{E}_{\text{system}} \stackrel{\phi^0(\text{steady})}{=} 0 \\ \dot{E}_{\text{in}} &= \dot{E}_{\text{out}} \\ \sum \dot{m}_e h_e &= \sum \dot{m}_i h_i \longrightarrow \dot{m}(h_3 - h_4) = \dot{m}(h_1 - h_6)\end{aligned}$$

or,

$$\dot{m}c_p(T_3 - T_4) = \dot{m}c_p(T_1 - T_6) \longrightarrow T_3 - T_4 = T_1 - T_6$$

Thus,

$$T_4 = T_3 - T_1 + T_6 = 20^\circ\text{C} - (-10^\circ\text{C}) + (-25^\circ\text{C}) = 5^\circ\text{C} = 278 \text{ K}$$

(b) From the isentropic relations,

$$\begin{aligned}T_2 &= T_1 \left(\frac{P_2}{P_1} \right)^{(k-1)/k} = (263 \text{ K})(3)^{0.667/1.667} = 408.2 \text{ K} = 135.2^\circ\text{C} \\ T_5 &= T_4 \left(\frac{P_5}{P_4} \right)^{(k-1)/k} = (278 \text{ K}) \left(\frac{1}{3} \right)^{0.667/1.667} = 179.1 \text{ K} = -93.9^\circ\text{C}\end{aligned}$$

Then the COP of this ideal gas refrigeration cycle is determined from

$$\begin{aligned}\text{COP}_R &= \frac{q_L}{w_{\text{net,in}}} = \frac{q_L}{w_{\text{comp,in}} - w_{\text{turb,out}}} = \frac{h_6 - h_5}{(h_2 - h_1) - (h_4 - h_5)} \\ &= \frac{T_6 - T_5}{(T_2 - T_1) - (T_4 - T_5)} = \frac{-25^\circ\text{C} - (-93.9^\circ\text{C})}{[135.2 - (-10)]^\circ\text{C} - [5 - (-93.9)]^\circ\text{C}} = \mathbf{1.49}\end{aligned}$$

(c) The net power input is determined from

$$\begin{aligned}\dot{W}_{\text{net,in}} &= \dot{W}_{\text{comp,in}} - \dot{W}_{\text{turb,out}} = \dot{m}[(h_2 - h_1) - (h_4 - h_5)] \\ &= \dot{m}c_p[(T_2 - T_1) - (T_4 - T_5)] \\ &= (0.45 \text{ kg/s})(5.1926 \text{ kJ/kg}\cdot^\circ\text{C})[(135.2 - (-10)) - [5 - (-93.9)]] \\ &= \mathbf{108.2 \text{ kW}}\end{aligned}$$

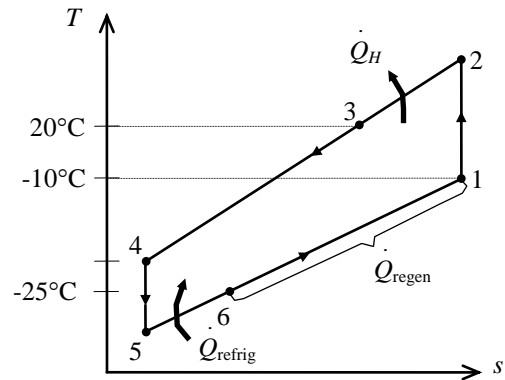

11-120 An absorption refrigeration system operating at specified conditions is considered. The minimum rate of heat supply required is to be determined.

Analysis The maximum COP that this refrigeration system can have is

$$\text{COP}_{R,\max} = \left(1 - \frac{T_0}{T_s}\right) \left(\frac{T_L}{T_0 - T_L}\right) = \left(1 - \frac{298 \text{ K}}{368 \text{ K}}\right) \left(\frac{275}{298 - 275}\right) = 2.274$$

Thus,

$$\dot{Q}_{\text{gen,min}} = \frac{\dot{Q}_L}{\text{COP}_{R,\max}} = \frac{28 \text{ kW}}{2.274} = \mathbf{12.3 \text{ kW}}$$



11-121 Problem 11-120 is reconsidered. The effect of the source temperature on the minimum rate of heat supply is to be investigated.

Analysis The problem is solved using EES, and the solution is given below.

"Input Data:"

T_L = 2 [C]

T_0 = 25 [C]

T_s = 95 [C]

Q_dot_L = 28 [kW]

"The maximum COP that this refrigeration system can have is:"

$\text{COP}_{R,\max} = (1 - (T_0 + 273)/(T_s + 273)) * ((T_L + 273)/(T_0 - T_L))$

"The minimum rate of heat supply is:"

$Q_{\text{dot_gen_min}} = Q_{\text{dot_L}} / \text{COP}_{R,\max}$

T _s [C]	Q _{gen,min} [kW]
50	30.26
75	16.3
100	11.65
125	9.32
150	7.925
175	6.994
200	6.33
225	5.831
250	5.443

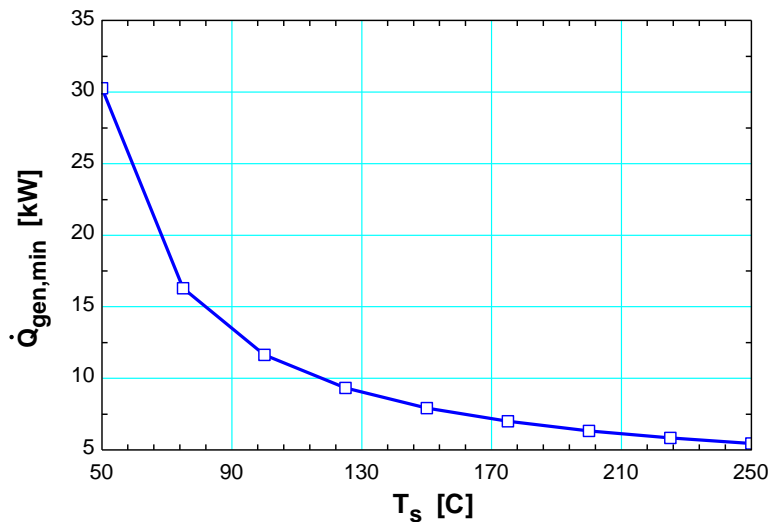

11-122 A regenerative gas refrigeration cycle using air as the working fluid is considered. The effectiveness of the regenerator, the rate of heat removal from the refrigerated space, the COP of the cycle, and the refrigeration load and the COP if this system operated on the simple gas refrigeration cycle are to be determined.

Assumptions 1 Steady operating conditions exist. 2 Kinetic and potential energy changes are negligible. 3 Air is an ideal gas with variable specific heats.

Analysis (a) For this problem, we use the properties of air from EES. Note that for an ideal gas enthalpy is a function of temperature only while entropy is functions of both temperature and pressure.

$$\begin{aligned}
 T_1 &= 0^\circ\text{C} \longrightarrow h_1 = 273.40 \text{ kJ/kg} \\
 P_1 &= 100 \text{ kPa} \\
 T_1 &= 0^\circ\text{C} \quad \left. \vphantom{\begin{array}{l} T_1 \\ P_1 \end{array}} \right\} s_1 = 5.6110 \text{ kJ/kg}\cdot\text{K} \\
 P_2 &= 500 \text{ kPa} \\
 s_2 &= s_1 \quad \left. \vphantom{\begin{array}{l} P_2 \\ s_2 \end{array}} \right\} h_{2s} = 433.50 \text{ kJ/kg} \\
 \eta_C &= \frac{h_{2s} - h_1}{h_2 - h_1} \\
 0.80 &= \frac{433.50 - 273.40}{h_2 - 273.40} \\
 h_2 &= 473.52 \text{ kJ/kg} \\
 T_3 &= 35^\circ\text{C} \longrightarrow h_3 = 308.63 \text{ kJ/kg}
 \end{aligned}$$

For the turbine inlet and exit we have

$$\begin{aligned}
 T_5 &= -80^\circ\text{C} \longrightarrow h_5 = 193.45 \text{ kJ/kg} \\
 T_4 &= ? \longrightarrow h_4 = \\
 \eta_T &= \frac{h_4 - h_5}{h_4 - h_{5s}} \\
 P_1 &= 100 \text{ kPa} \\
 T_1 &= 0^\circ\text{C} \quad \left. \vphantom{\begin{array}{l} P_1 \\ T_1 \end{array}} \right\} s_1 = 5.6110 \text{ kJ/kg}\cdot\text{K} \\
 P_4 &= 500 \text{ kPa} \\
 T_4 &= ? \quad \left. \vphantom{\begin{array}{l} P_4 \\ T_4 \end{array}} \right\} s_4 = \\
 P_5 &= 500 \text{ kPa} \\
 s_5 &= s_4 \quad \left. \vphantom{\begin{array}{l} P_5 \\ s_5 \end{array}} \right\} h_{5s} =
 \end{aligned}$$

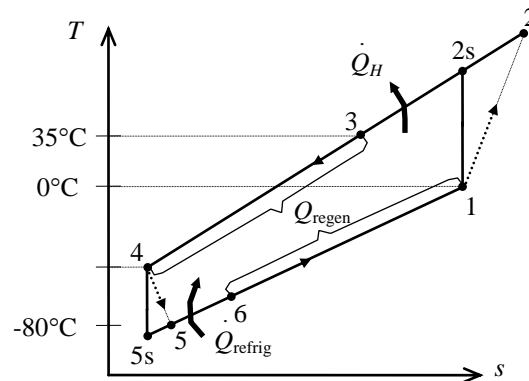
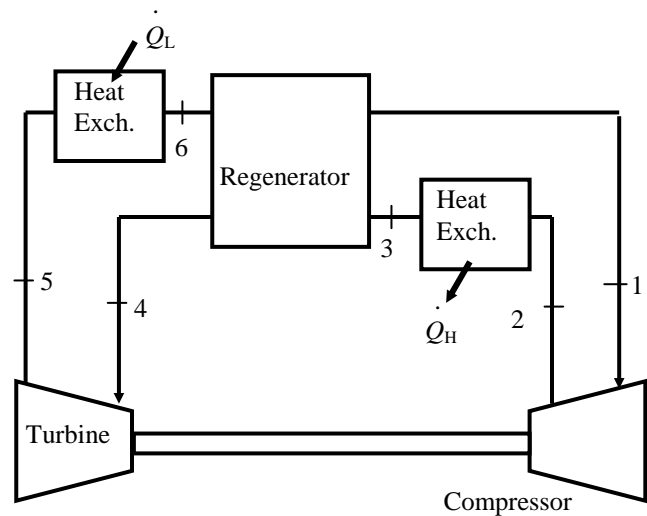

We can determine the temperature at the turbine inlet from EES using the above relations. A hand solution would require a trial-error approach.

$$T_4 = 281.8 \text{ K}, \quad h_4 = 282.08 \text{ kJ/kg}$$

An energy balance on the regenerator gives

$$h_6 = h_1 - h_3 + h_4 = 273.40 - 308.63 + 282.08 = 246.85 \text{ kJ/kg}$$

The effectiveness of the regenerator is determined from

$$\varepsilon_{\text{regen}} = \frac{h_3 - h_4}{h_3 - h_6} = \frac{308.63 - 282.08}{308.63 - 246.85} = \mathbf{0.430}$$

(b) The refrigeration load is

$$\dot{Q}_L = \dot{m}(h_6 - h_5) = (0.4 \text{ kg/s})(246.85 - 193.45) \text{ kJ/kg} = \mathbf{21.36 \text{ kW}}$$

(c) The turbine and compressor powers and the COP of the cycle are

$$\dot{W}_{C,in} = \dot{m}(h_2 - h_1) = (0.4 \text{ kg/s})(473.52 - 273.40) \text{ kJ/kg} = 80.05 \text{ kW}$$

$$\dot{W}_{T,out} = \dot{m}(h_4 - h_5) = (0.4 \text{ kg/s})(282.08 - 193.45) \text{ kJ/kg} = 35.45 \text{ kW}$$

$$\text{COP} = \frac{\dot{Q}_L}{\dot{W}_{\text{net,in}}} = \frac{\dot{Q}_L}{\dot{W}_{C,in} - \dot{W}_{T,out}} = \frac{21.36}{80.05 - 35.45} = \mathbf{0.479}$$

(d) The simple gas refrigeration cycle analysis is as follows:

$$h_1 = 273.40 \text{ kJ/kg}$$

$$h_2 = 473.52 \text{ kJ/kg}$$

$$h_3 = 308.63 \text{ kJ/kg}$$

$$\left. \begin{array}{l} P_3 = 500 \text{ kPa} \\ T_3 = 35^\circ\text{C} \end{array} \right\} s_3 = 5.2704 \text{ kJ/kg}$$

$$\left. \begin{array}{l} P_1 = 100 \text{ kPa} \\ s_4 = s_3 \end{array} \right\} h_{4s} = 194.52 \text{ kJ/kg.K}$$

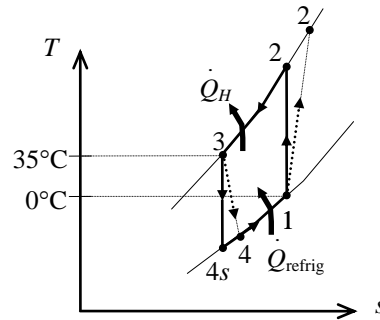

$$\eta_T = \frac{h_3 - h_4}{h_3 - h_{4s}} \rightarrow 0.85 = \frac{308.63 - h_4}{308.63 - 194.52} \rightarrow h_4 = 211.64 \text{ kJ/kg}$$

$$\dot{Q}_L = \dot{m}(h_1 - h_4) = (0.4 \text{ kg/s})(273.40 - 211.64) \text{ kJ/kg} = \mathbf{24.70 \text{ kW}}$$

$$\dot{W}_{\text{net,in}} = \dot{m}(h_2 - h_1) - \dot{m}(h_3 - h_4) = (0.4 \text{ kg/s})[(473.52 - 273.40) - (308.63 - 211.64) \text{ kJ/kg}] = 41.25 \text{ kW}$$

$$\text{COP} = \frac{\dot{Q}_L}{\dot{W}_{\text{net,in}}} = \frac{24.70}{41.25} = \mathbf{0.599}$$

The complete EES code for the solution of this problem is given next:

"GIVEN"

$$r=5$$

$$T[1]=(0+273.15) \text{ [K]}$$

$$T[3]=(35+273.15) \text{ [K]}$$

$$T[5]=(-80+273.15) \text{ [K]}$$

$$m_dot=0.4 \text{ [kg/s]}$$

$$\text{eta_C}=0.80$$

$$\text{eta_T}=0.85$$

$$P_1=100 \text{ [kPa]} \text{ "assumed"}$$

$$P_2=P_1*r$$

"PROPERTIES"

$$\text{Fluid\$}='Air'$$

$$h[1]=\text{enthalpy}(\text{Fluid\$}, T=T[1])$$

$$s_1=\text{entropy}(\text{Fluid\$}, T=T[1], P=P_1)$$

$$h[3]=\text{enthalpy}(\text{Fluid\$}, T=T[3])$$

$$h[5]=\text{enthalpy}(\text{Fluid\$}, T=T[5])$$

"ANALYSIS"

$$h_2s=\text{enthalpy}(\text{Fluid\$}, P=P_2, s=s_1)$$

$$h[2]=h[1]+(h_2s-h[1])/\text{eta_C}$$

$$h[4]=\text{enthalpy}(\text{Fluid\$}, T=T[4])$$

$$h[4]=h[5]+\text{eta_T}*(h[4]-h_5s)$$

$$h_5s=\text{enthalpy}(\text{Fluid\$}, P=P_1, s=s_4)$$

$$s_4=\text{entropy}(\text{Fluid\$}, T=T[4], P=P_2)$$

$$h[6]=h[1]-h[3]+h[4] \text{ "energy balance on the regenerator"}$$

```

epsilon_regen=(h[3]-h[4])/(h[3]-h[6]) "regenerator effectiveness"
Q_dot_L=m_dot*(h[6]-h[5]) "refrigeration load"
W_dot_net_in=W_dot_C_in-W_dot_T_out
W_dot_C_in=m_dot*(h[2]-h[1])
W_dot_T_out=m_dot*(h[4]-h[5])
COP=Q_dot_L/W_dot_net_in "COP of cycle"

```

"Simple gas refrigeration cycle analysis, the subscript 'a' is used"

```

h_a[1]=h[1]
h_a[2]=h[2]
h_a[3]=h[3]
s_3_a=entropy(Fluid$, h=h_a[3], P=P_2)
h_4s_a=enthalpy(Fluid$, P=P_1, s=s_3_a)
h_a[4]=h_a[3]-eta_T*(h_a[3]-h_4s_a)
Q_dot_L_a=m_dot*(h_a[1]-h_a[4])
W_dot_in_net_a=m_dot*(h_a[2]-h_a[1])-m_dot*(h_a[3]-h_a[4])
COP_a=Q_dot_L_a/W_dot_in_net_a

```

11-123 An innovative vapor-compression refrigeration system with a heat exchanger is considered. The system's COP is to be determined.

Assumptions 1 Steady operating conditions exist. 2 Kinetic and potential energy changes are negligible.

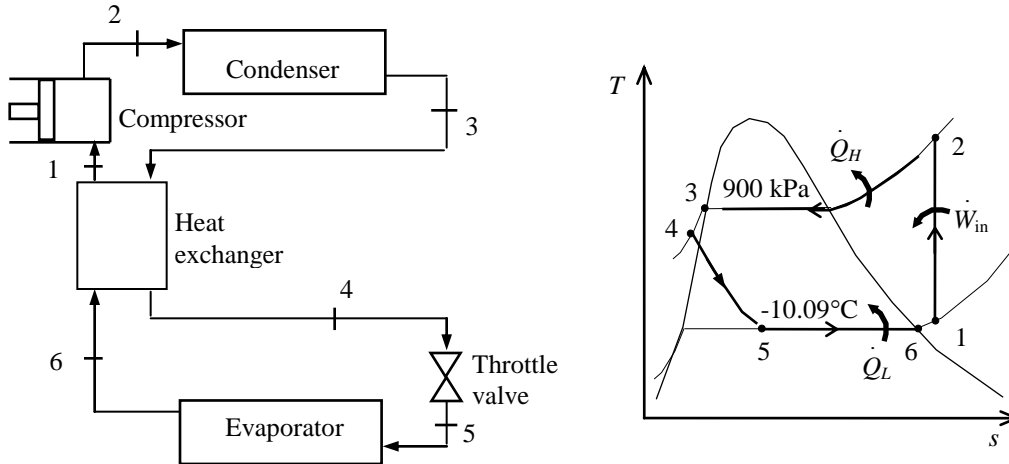

Analysis From the refrigerant tables (Tables A-11, A-12, and A-13),

$$\left. \begin{array}{l} P_3 = 900 \text{ kPa} \\ \text{sat. liquid} \end{array} \right\} h_3 = h_f @ 900 \text{ kPa} = 101.62 \text{ kJ/kg}$$

$$\left. \begin{array}{l} T_4 = T_{\text{sat} @ 900 \text{ kPa}} - 11.3 \\ = 35.51 - 5.51 = 30^\circ \text{C} \\ P_4 = 900 \text{ kPa} \end{array} \right\} h_4 \cong h_f @ 30^\circ \text{C} = 93.58 \text{ kJ/kg}$$

$$h_5 \cong h_4 = 93.58 \text{ kJ/kg} \quad (\text{throttling})$$

$$\left. \begin{array}{l} T_6 = -10.09^\circ \text{C} \\ \text{sat. vapor} \end{array} \right\} \begin{array}{l} h_6 = h_g @ -10.09^\circ \text{C} = 244.50 \text{ kJ/kg} \\ P_6 = P_{\text{sat} @ -10.09^\circ \text{C}} = 200 \text{ kPa} \end{array}$$

An energy balance on the heat exchanger gives

$$\dot{m}(h_1 - h_6) = \dot{m}(h_3 - h_4) \longrightarrow h_1 = h_3 - h_4 + h_6 = 101.62 - 93.58 + 244.50 = 252.54 \text{ kJ/kg}$$

Then,

$$\left. \begin{array}{l} P_1 = 200 \text{ kPa} \\ h_1 = 252.54 \text{ kJ/kg} \end{array} \right\} s_1 = 0.9679 \text{ kJ/kg} \cdot \text{K}$$

$$\left. \begin{array}{l} P_2 = 900 \text{ kPa} \\ s_2 = s_1 \end{array} \right\} h_2 = 285.37 \text{ kJ/kg}$$

The COP of this refrigeration system is determined from its definition,

$$\text{COP}_R = \frac{q_L}{w_{\text{in}}} = \frac{h_6 - h_5}{h_2 - h_1} = \frac{244.50 - 93.58}{285.37 - 252.54} = \mathbf{4.60}$$

11-124 An innovative vapor-compression refrigeration system with a heat exchanger is considered. The system's COP is to be determined.

Assumptions 1 Steady operating conditions exist. 2 Kinetic and potential energy changes are negligible.

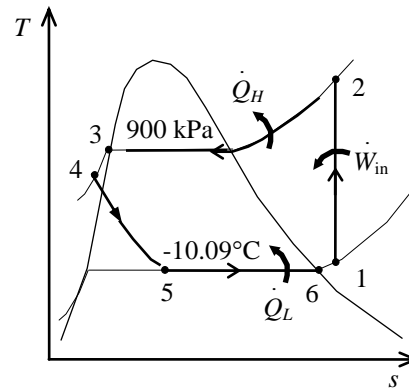
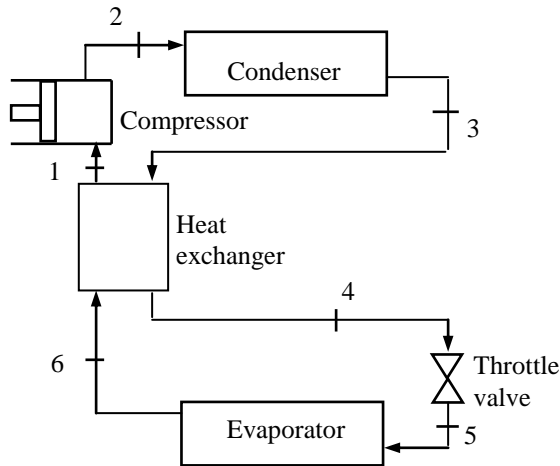

Analysis From the refrigerant tables (Tables A-11, A-12, and A-13),

$$\left. \begin{array}{l} P_3 = 900 \text{ kPa} \\ \text{sat. liquid} \end{array} \right\} h_3 = h_f @ 900 \text{ kPa} = 101.62 \text{ kJ/kg}$$

$$\left. \begin{array}{l} T_4 = T_{\text{sat} @ 900 \text{ kPa}} - 9.51 \\ = 35.51 - 9.51 = 26^\circ\text{C} \\ P_4 = 900 \text{ kPa} \end{array} \right\} h_4 \cong h_f @ 26^\circ\text{C} = 87.82 \text{ kJ/kg}$$

$$h_5 \cong h_4 = 87.82 \text{ kJ/kg} \quad (\text{throttling})$$

$$\left. \begin{array}{l} T_6 = -10.09^\circ\text{C} \\ \text{sat. vapor} \end{array} \right\} \begin{array}{l} h_6 = h_g @ -10.09^\circ\text{C} = 244.50 \text{ kJ/kg} \\ P_6 = P_{\text{sat} @ -10.09^\circ\text{C}} = 200 \text{ kPa} \end{array}$$

An energy balance on the heat exchanger gives

$$\dot{m}(h_1 - h_6) = \dot{m}(h_3 - h_4) \longrightarrow h_1 = h_3 - h_4 + h_6 = 101.62 - 87.82 + 244.50 = 258.29 \text{ kJ/kg}$$

Then,

$$\left. \begin{array}{l} P_1 = 200 \text{ kPa} \\ h_1 = 258.29 \text{ kJ/kg} \end{array} \right\} s_1 = 0.9888 \text{ kJ/kg} \cdot \text{K}$$

$$\left. \begin{array}{l} P_2 = 900 \text{ kPa} \\ s_2 = s_1 \end{array} \right\} h_2 = 292.19 \text{ kJ/kg}$$

The COP of this refrigeration system is determined from its definition,

$$\text{COP}_R = \frac{q_L}{w_{\text{in}}} = \frac{h_6 - h_5}{h_2 - h_1} = \frac{244.50 - 87.82}{292.19 - 258.29} = \mathbf{4.62}$$

11-125 An ideal gas refrigeration cycle with with three stages of compression with intercooling using air as the working fluid is considered. The COP of this system is to be determined.

Assumptions 1 Steady operating conditions exist. **2** Air is an ideal gas with constant specific heats. **3** Kinetic and potential energy changes are negligible.

Properties The properties of air at room temperature are $c_p = 1.005 \text{ kJ/kg}\cdot\text{K}$ and $k = 1.4$ (Table A-2a).

Analysis From the isentropic relations,

$$T_2 = T_1 \left(\frac{P_2}{P_1} \right)^{(k-1)/k} = (243 \text{ K})(7)^{0.4/1.4} = 423.7 \text{ K}$$

$$T_4 = T_6 = T_3 \left(\frac{P_4}{P_3} \right)^{(k-1)/k} = (288 \text{ K})(7)^{0.4/1.4} = 502.2 \text{ K}$$

$$T_8 = T_7 \left(\frac{P_8}{P_7} \right)^{(k-1)/k} = (288 \text{ K}) \left(\frac{1}{7 \times 7 \times 7} \right)^{0.4/1.4} = 54.3 \text{ K}$$

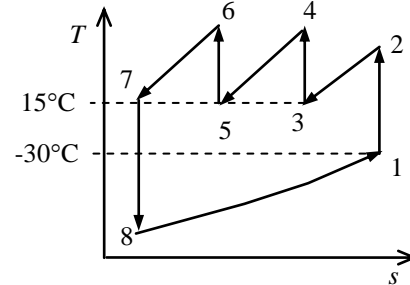

The COP of this ideal gas refrigeration cycle is determined from

$$\begin{aligned} \text{COP}_R &= \frac{q_L}{w_{\text{net,in}}} = \frac{q_L}{w_{\text{comp,in}} - w_{\text{turb,out}}} \\ &= \frac{h_1 - h_8}{(h_2 - h_1) + (h_4 - h_3) + (h_6 - h_5) - (h_7 - h_8)} \\ &= \frac{T_1 - T_8}{(T_2 - T_1) + 2(T_4 - T_3) - (T_7 - T_8)} \\ &= \frac{243 - 54.3}{(423.7 - 243) + 2(502.2 - 288) - (288 - 54.3)} \\ &= \mathbf{0.503} \end{aligned}$$



11-126 The effect of the evaporator pressure on the COP of an ideal vapor-compression refrigeration cycle with R-134a as the working fluid is to be investigated.

Analysis The problem is solved using EES, and the solution is given below.

"Input Data"

P[1]=100 [kPa]

P[2] = 1400 [kPa]

Fluid\$='R134a'

Eta_c=1.0 "Compressor isentropic efficiency"

"Compressor"

h[1]=enthalpy(Fluid\$,P=P[1],x=1) "properties for state 1"

s[1]=entropy(Fluid\$,P=P[1],x=1)

T[1]=temperature(Fluid\$,h=h[1],P=P[1])

h2s=enthalpy(Fluid\$,P=P[2],s=s[1]) "Identifies state 2s as isentropic"

h[1]+Wcs=h2s "energy balance on isentropic compressor"

W_c=Wcs/Eta_c "definition of compressor isentropic efficiency"

h[1]+W_c=h[2] "energy balance on real compressor-assumed adiabatic"

s[2]=entropy(Fluid\$,h=h[2],P=P[2]) "properties for state 2"

T[2]=temperature(Fluid\$,h=h[2],P=P[2])

"Condenser"

P[3] = P[2]

h[3]=enthalpy(Fluid\$,P=P[3],x=0) "properties for state 3"

s[3]=entropy(Fluid\$,P=P[3],x=0)

h[2]=Qout+h[3] "energy balance on condenser"

"Throttle Valve"

h[4]=h[3] "energy balance on throttle - isenthalpic"

x[4]=quality(Fluid\$,h=h[4],P=P[4]) "properties for state 4"

s[4]=entropy(Fluid\$,h=h[4],P=P[4])

T[4]=temperature(Fluid\$,h=h[4],P=P[4])

"Evaporator"

P[4]= P[1]

Q_in + h[4]=h[1] "energy balance on evaporator"

"Coefficient of Performance:"

COP=Q_in/W_c "definition of COP"

P ₁ [kPa]	COP	η _c
100	1.937	1
150	2.416	1
200	2.886	1
250	3.363	1
300	3.859	1
350	4.384	1
400	4.946	1
450	5.555	1
500	6.22	1

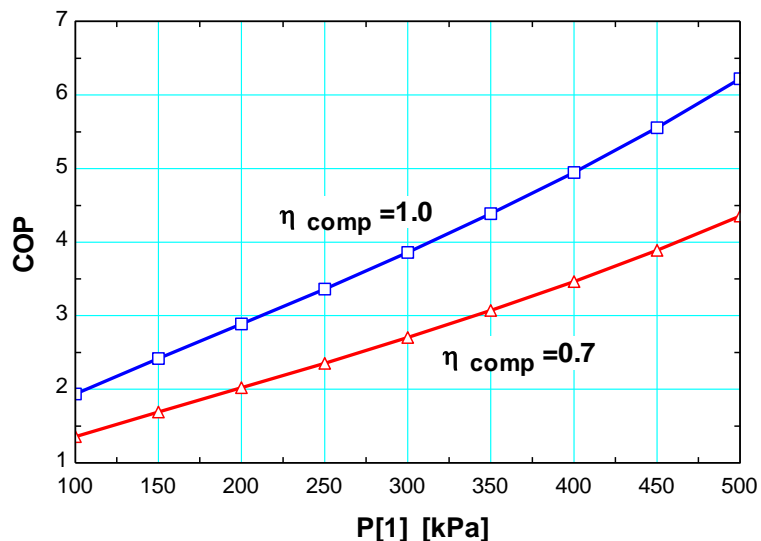



11-127 The effect of the condenser pressure on the COP of an ideal vapor-compression refrigeration cycle with R-134a as the working fluid is to be investigated.

Analysis The problem is solved using EES, and the solution is given below.

"Input Data"

P[1]=150 [kPa]

P[2] = 400 [kPa]

Fluid\$='R134a'

Eta_c=0.7 "Compressor isentropic efficiency"

"Compressor"

h[1]=enthalpy(Fluid\$,P=P[1],x=1) "properties for state 1"

s[1]=entropy(Fluid\$,P=P[1],x=1)

T[1]=temperature(Fluid\$,h=h[1],P=P[1])

h2s=enthalpy(Fluid\$,P=P[2],s=s[1]) "Identifies state 2s as isentropic"

h[1]+Wcs=h2s "energy balance on isentropic compressor"

W_c=Wcs/Eta_c "definition of compressor isentropic efficiency"

h[1]+W_c=h[2] "energy balance on real compressor-assumed adiabatic"

s[2]=entropy(Fluid\$,h=h[2],P=P[2]) "properties for state 2"

T[2]=temperature(Fluid\$,h=h[2],P=P[2])

"Condenser"

P[3] = P[2]

h[3]=enthalpy(Fluid\$,P=P[3],x=0) "properties for state 3"

s[3]=entropy(Fluid\$,P=P[3],x=0)

h[2]=Qout+h[3] "energy balance on condenser"

"Throttle Valve"

h[4]=h[3] "energy balance on throttle - isenthalpic"

x[4]=quality(Fluid\$,h=h[4],P=P[4]) "properties for state 4"

s[4]=entropy(Fluid\$,h=h[4],P=P[4])

T[4]=temperature(Fluid\$,h=h[4],P=P[4])

"Evaporator"

P[4]= P[1]

Q_in + h[4]=h[1] "energy balance on evaporator"

"Coefficient of Performance:"

COP=Q_in/W_c "definition of COP"

P ₂ [kPa]	COP	η _c
400	6.163	0.7
500	4.722	0.7
600	3.882	0.7
700	3.32	0.7
800	2.913	0.7
900	2.6	0.7
1000	2.351	0.7
1100	2.145	0.7
1200	1.971	0.7
1300	1.822	0.7
1400	1.692	0.7

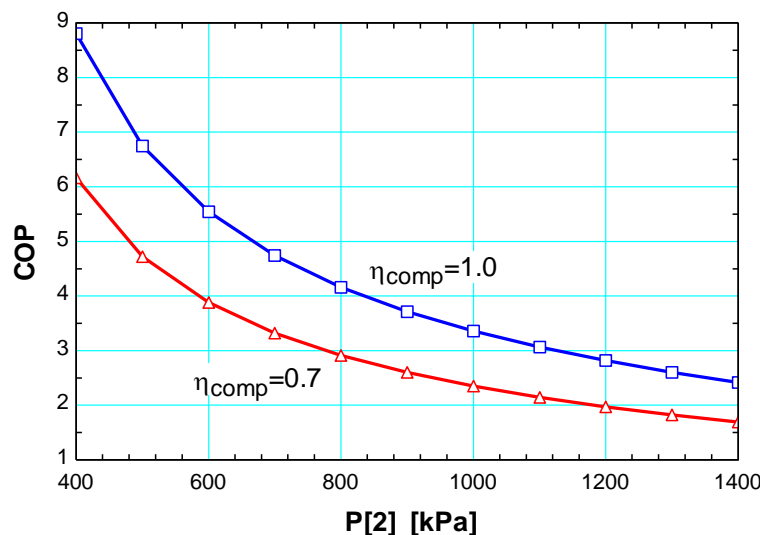

11-128 A relation for the COP of the two-stage refrigeration system with a flash chamber shown in Fig. 11-14 is to be derived.

Analysis The coefficient of performance is determined from

$$\text{COP}_R = \frac{q_L}{w_{\text{in}}}$$

where

$$q_L = (1 - x_6)(h_1 - h_8) \quad \text{with} \quad x_6 = \frac{h_6 - h_f}{h_{fg}}$$

$$w_{\text{in}} = w_{\text{compI, in}} + w_{\text{compII, in}} = (1 - x_6)(h_2 - h_1) + (1)(h_4 - h_3)$$

Fundamentals of Engineering (FE) Exam Problems

11-129 Consider a heat pump that operates on the reversed Carnot cycle with R-134a as the working fluid executed under the saturation dome between the pressure limits of 140 kPa and 800 kPa. R-134a changes from saturated vapor to saturated liquid during the heat rejection process. The net work input for this cycle is

- (a) 28 kJ/kg (b) 34 kJ/kg (c) 49 kJ/kg (d) 144 kJ/kg (e) 275 kJ/kg

Answer (a) 28 kJ/kg

Solution Solved by EES Software. Solutions can be verified by copying-and-pasting the following lines on a blank EES screen. (Similar problems and their solutions can be obtained easily by modifying numerical values).

```
P1=800 "kPa"
P2=140 "kPa"
h_fg=ENTHALPY(R134a,x=1,P=P1)-ENTHALPY(R134a,x=0,P=P1)
TH=TEMPERATURE(R134a,x=0,P=P1)+273
TL=TEMPERATURE(R134a,x=0,P=P2)+273
q_H=h_fg
COP=TH/(TH-TL)
w_net=q_H/COP
```

"Some Wrong Solutions with Common Mistakes:"

```
W1_work = q_H/COP1; COP1=TL/(TH-TL) "Using COP of refrigerator"
W2_work = q_H/COP2; COP2=(TH-273)/(TH-TL) "Using C instead of K"
W3_work = h_fg3/COP; h_fg3= ENTHALPY(R134a,x=1,P=P2)-ENTHALPY(R134a,x=0,P=P2) "Using h_fg at P2"
W4_work = q_H*TL/TH "Using the wrong relation"
```

11-130 A refrigerator removes heat from a refrigerated space at 0°C at a rate of 2.2 kJ/s and rejects it to an environment at 20°C. The minimum required power input is

- (a) 89 W (b) 150 W (c) 161 W (d) 557 W (e) 2200 W

Answer (c) 161 W

Solution Solved by EES Software. Solutions can be verified by copying-and-pasting the following lines on a blank EES screen. (Similar problems and their solutions can be obtained easily by modifying numerical values).

```
TH=20+273
TL=0+273
Q_L=2.2 "kJ/s"
COP_max=TL/(TH-TL)
w_min=Q_L/COP_max
```

"Some Wrong Solutions with Common Mistakes:"

```
W1_work = Q_L/COP1; COP1=TH/(TH-TL) "Using COP of heat pump"
W2_work = Q_L/COP2; COP2=(TH-273)/(TH-TL) "Using C instead of K"
W3_work = Q_L*TL/TH "Using the wrong relation"
W4_work = Q_L "Taking the rate of refrigeration as power input"
```

11-131 A refrigerator operates on the ideal vapor compression refrigeration cycle with R-134a as the working fluid between the pressure limits of 120 kPa and 800 kPa. If the rate of heat removal from the refrigerated space is 32 kJ/s, the mass flow rate of the refrigerant is

- (a) 0.19 kg/s (b) 0.15 kg/s (c) 0.23 kg/s (d) 0.28 kg/s (e) 0.81 kg/s

Answer (c) 0.23 kg/s

Solution Solved by EES Software. Solutions can be verified by copying-and-pasting the following lines on a blank EES screen. (Similar problems and their solutions can be obtained easily by modifying numerical values).

```
P1=120 "kPa"
P2=800 "kPa"
P3=P2
P4=P1
s2=s1
Q_refrig=32 "kJ/s"
m=Q_refrig/(h1-h4)
h1=ENTHALPY(R134a,x=1,P=P1)
s1=ENTROPY(R134a,x=1,P=P1)
h2=ENTHALPY(R134a,s=s2,P=P2)
h3=ENTHALPY(R134a,x=0,P=P3)
h4=h3
```

"Some Wrong Solutions with Common Mistakes:"

```
W1_mass = Q_refrig/(h2-h1) "Using wrong enthalpies, for W_in"
W2_mass = Q_refrig/(h2-h3) "Using wrong enthalpies, for Q_H"
W3_mass = Q_refrig/(h1-h44); h44=ENTHALPY(R134a,x=0,P=P4) "Using wrong enthalpy h4 (at P4)"
W4_mass = Q_refrig/h_fg; h_fg=ENTHALPY(R134a,x=1,P=P2) - ENTHALPY(R134a,x=0,P=P2) "Using h_fg at P2"
```

11-132 A heat pump operates on the ideal vapor compression refrigeration cycle with R-134a as the working fluid between the pressure limits of 0.32 MPa and 1.2 MPa. If the mass flow rate of the refrigerant is 0.193 kg/s, the rate of heat supply by the heat pump to the heated space is

- (a) 3.3 kW (b) 23 kW (c) 26 kW (d) 31 kW (e) 45 kW

Answer (d) 31 kW

Solution Solved by EES Software. Solutions can be verified by copying-and-pasting the following lines on a blank EES screen. (Similar problems and their solutions can be obtained easily by modifying numerical values).

```
P1=320 "kPa"
P2=1200 "kPa"
P3=P2
P4=P1
s2=s1
m=0.193 "kg/s"
Q_supply=m*(h2-h3) "kJ/s"
h1=ENTHALPY(R134a,x=1,P=P1)
s1=ENTROPY(R134a,x=1,P=P1)
h2=ENTHALPY(R134a,s=s2,P=P2)
h3=ENTHALPY(R134a,x=0,P=P3)
h4=h3
```

"Some Wrong Solutions with Common Mistakes:"

```
W1_Qh = m*(h2-h1) "Using wrong enthalpies, for W_in"
W2_Qh = m*(h1-h4) "Using wrong enthalpies, for Q_L"
W3_Qh = m*(h2-h4); h22=ENTHALPY(R134a,x=1,P=P2) "Using wrong enthalpy h2 (hg at P2)"
W4_Qh = m*h_fg; h_fg=ENTHALPY(R134a,x=1,P=P1) - ENTHALPY(R134a,x=0,P=P1) "Using h_fg at P1"
```

11-133 An ideal vapor compression refrigeration cycle with R-134a as the working fluid operates between the pressure limits of 120 kPa and 700 kPa. The mass fraction of the refrigerant that is in the liquid phase at the inlet of the evaporator is

- (a) 0.69 (b) 0.63 (c) 0.58 (d) 0.43 (e) 0.35

Answer (a) 0.69

Solution Solved by EES Software. Solutions can be verified by copying-and-pasting the following lines on a blank EES screen. (Similar problems and their solutions can be obtained easily by modifying numerical values).

```
P1=120 "kPa"
P2=700 "kPa"
P3=P2
P4=P1
h1=ENTHALPY(R134a,x=1,P=P1)
h3=ENTHALPY(R134a,x=0,P=P3)
h4=h3
x4=QUALITY(R134a,h=h4,P=P4)
liquid=1-x4
```

"Some Wrong Solutions with Common Mistakes:"

```
W1_liquid = x4 "Taking quality as liquid content"
W2_liquid = 0 "Assuming superheated vapor"
W3_liquid = 1-x4s; x4s=QUALITY(R134a,s=s3,P=P4) "Assuming isentropic expansion"
s3=ENTROPY(R134a,x=0,P=P3)
```

11-134 Consider a heat pump that operates on the ideal vapor compression refrigeration cycle with R-134a as the working fluid between the pressure limits of 0.32 MPa and 1.2 MPa. The coefficient of performance of this heat pump is

- (a) 0.17 (b) 1.2 (c) 3.1 (d) 4.9 (e) 5.9

Answer (e) 5.9

Solution Solved by EES Software. Solutions can be verified by copying-and-pasting the following lines on a blank EES screen. (Similar problems and their solutions can be obtained easily by modifying numerical values).

```
P1=320 "kPa"
P2=1200 "kPa"
P3=P2
P4=P1
s2=s1
h1=ENTHALPY(R134a,x=1,P=P1)
s1=ENTROPY(R134a,x=1,P=P1)
h2=ENTHALPY(R134a,s=s2,P=P2)
h3=ENTHALPY(R134a,x=0,P=P3)
h4=h3
COP_HP=qH/Win
Win=h2-h1
qH=h2-h3
```

"Some Wrong Solutions with Common Mistakes:"

```
W1_COP = (h1-h4)/(h2-h1) "COP of refrigerator"
W2_COP = (h1-h4)/(h2-h3) "Using wrong enthalpies, QL/QH"
W3_COP = (h2-h3)/(h2-h1); h2=ENTHALPY(R134a,x=1,P=P2) "Using wrong enthalpy h2 (hg at P2)"
```

11-135 An ideal gas refrigeration cycle using air as the working fluid operates between the pressure limits of 80 kPa and 280 kPa. Air is cooled to 35°C before entering the turbine. The lowest temperature of this cycle is

- (a) -58°C (b) -26°C (c) 0°C (d) 11°C (e) 24°C

Answer (a) -58°C

Solution Solved by EES Software. Solutions can be verified by copying-and-pasting the following lines on a blank EES screen. (Similar problems and their solutions can be obtained easily by modifying numerical values).

```
k=1.4
P1= 80 "kPa"
P2=280 "kPa"
T3=35+273 "K"
"Mimumum temperature is the turbine exit temperature"
T4=T3*(P1/P2)^((k-1)/k) - 273
```

"Some Wrong Solutions with Common Mistakes:"

```
W1_Tmin = (T3-273)*(P1/P2)^((k-1)/k) "Using C instead of K"
W2_Tmin = T3*(P1/P2)^((k-1)) - 273 "Using wrong exponent"
W3_Tmin = T3*(P1/P2)^k - 273 "Using wrong exponent"
```

11-136 Consider an ideal gas refrigeration cycle using helium as the working fluid. Helium enters the compressor at 100 kPa and 17°C and is compressed to 400 kPa. Helium is then cooled to 20°C before it enters the turbine. For a mass flow rate of 0.2 kg/s, the net power input required is

- (a) 28.3 kW (b) 40.5 kW (c) 64.7 kW (d) 93.7 kW (e) 113 kW

Answer (d) 93.7 kW

Solution Solved by EES Software. Solutions can be verified by copying-and-pasting the following lines on a blank EES screen. (Similar problems and their solutions can be obtained easily by modifying numerical values).

```
k=1.667
Cp=5.1926 "kJ/kg.K"
P1= 100 "kPa"
T1=17+273 "K"
P2=400 "kPa"
T3=20+273 "K"
m=0.2 "kg/s"
"Minimum temperature is the turbine exit temperature"
T2=T1*(P2/P1)^((k-1)/k)
T4=T3*(P1/P2)^((k-1)/k)
W_netin=m*Cp*((T2-T1)-(T3-T4))
```

"Some Wrong Solutions with Common Mistakes:"

```
W1_Win = m*Cp*((T2-T1)-(T3-T4)); T2=T1*P2/P1; T4=T3*P1/P2 "Using wrong relations for temps"
W2_Win = m*Cp*(T2-T1) "Ignoring turbine work"
W3_Win=m*1.005*((T2B-T1)-(T3-T4B)); T2B=T1*(P2/P1)^((kB-1)/kB); T4B=T3*(P1/P2)^((kB-1)/kB); kB=1.4
"Using air properties"
W4_Win=m*Cp*((T2A-(T1-273))-(T3-273-T4A)); T2A=(T1-273)*(P2/P1)^((k-1)/k); T4A=(T3-273)*(P1/P2)^((k-1)/k) "Using C instead of K"
```

11-137 An absorption air-conditioning system is to remove heat from the conditioned space at 20°C at a rate of 150 kJ/s while operating in an environment at 35°C. Heat is to be supplied from a geothermal source at 140°C. The minimum rate of heat supply required is

- (a) 86 kJ/s (b) 21 kJ/s (c) 30 kJ/s (d) 61 kJ/s (e) 150 kJ/s

Answer (c) 30 kJ/s

Solution Solved by EES Software. Solutions can be verified by copying-and-pasting the following lines on a blank EES screen. (Similar problems and their solutions can be obtained easily by modifying numerical values).

```
TL=20+273 "K"
Q_refrig=150 "kJ/s"
To=35+273 "K"
Ts=140+273 "K"
COP_max=(1-To/Ts)*(TL/(To-TL))
Q_in=Q_refrig/COP_max
```

"Some Wrong Solutions with Common Mistakes:"

```
W1_Qin = Q_refrig "Taking COP = 1"
W2_Qin = Q_refrig/COP2; COP2=TL/(Ts-TL) "Wrong COP expression"
W3_Qin = Q_refrig/COP3; COP3=(1-To/Ts)*(Ts/(To-TL)) "Wrong COP expression, COP_HP"
W4_Qin = Q_refrig*COP_max "Multiplying by COP instead of dividing"
```

11-138 Consider a refrigerator that operates on the vapor compression refrigeration cycle with R-134a as the working fluid. The refrigerant enters the compressor as saturated vapor at 160 kPa, and exits at 800 kPa and 50°C, and leaves the condenser as saturated liquid at 800 kPa. The coefficient of performance of this refrigerator is

- (a) 2.6 (b) 1.0 (c) 4.2 (d) 3.2 (e) 4.4

Answer (d) 3.2

Solution Solved by EES Software. Solutions can be verified by copying-and-pasting the following lines on a blank EES screen. (Similar problems and their solutions can be obtained easily by modifying numerical values).

```
P1=160 "kPa"
P2=800 "kPa"
T2=50 "C"
P3=P2
P4=P1
h1=ENTHALPY(R134a,x=1,P=P1)
s1=ENTROPY(R134a,x=1,P=P1)
h2=ENTHALPY(R134a,T=T2,P=P2)
h3=ENTHALPY(R134a,x=0,P=P3)
h4=h3
COP_R=qL/Win
Win=h2-h1
qL=h1-h4
```

"Some Wrong Solutions with Common Mistakes:"

W1_COP = (h2-h3)/(h2-h1) "COP of heat pump"

W2_COP = (h1-h4)/(h2-h3) "Using wrong enthalpies, QL/QH"

W3_COP = (h1-h4)/(h2s-h1); h2s=ENTHALPY(R134a,s=s1,P=P2) "Assuming isentropic compression"

11-139 ... 11-146 Design and Essay Problems



Solutions Manual for
Thermodynamics: An Engineering Approach
8th Edition
Yunus A. Çengel, Michael A. Boles
McGraw-Hill, 2015

Chapter 12
THERMODYNAMIC PROPERTY
RELATIONS

PROPRIETARY AND CONFIDENTIAL

This Manual is the proprietary property of McGraw-Hill Education and protected by copyright and other state and federal laws. By opening and using this Manual the user agrees to the following restrictions, and if the recipient does not agree to these restrictions, the Manual should be promptly returned unopened to McGraw-Hill Education: **This Manual is being provided only to authorized professors and instructors for use in preparing for the classes using the affiliated textbook. No other use or distribution of this Manual is permitted. This Manual may not be sold and may not be distributed to or used by any student or other third party. No part of this Manual may be reproduced, displayed or distributed in any form or by any means, electronic or otherwise, without the prior written permission of McGraw-Hill Education.**

Partial Derivatives and Associated Relations

12-1C For functions that depend on one variable, they are identical. For functions that depend on two or more variable, the partial differential represents the change in the function with one of the variables as the other variables are held constant. The ordinary differential for such functions represents the total change as a result of differential changes in all variables.

12-2C Only when $(\partial z/\partial x)_y = 0$. That is, when z does not depend on y and thus $z = z(x)$.

12-3C It indicates that z does not depend on y . That is, $z = z(x)$.

12-4C (a) $(\partial x)_y = dx$; (b) $(\partial z)_y \leq dz$; and (c) $dz = (\partial z)_x + (\partial z)_y$

12-5 Air at a specified temperature and specific volume is considered. The changes in pressure corresponding to a certain increase of different properties are to be determined.

Assumptions Air is an ideal gas.

Properties The gas constant of air is $R = 0.287 \text{ kPa} \cdot \text{m}^3/\text{kg} \cdot \text{K}$ (Table A-1).

Analysis An ideal gas equation can be expressed as $P = RT/\nu$. Noting that R is a constant and $P = P(T, \nu)$,

$$dP = \left(\frac{\partial P}{\partial T} \right)_{\nu} dT + \left(\frac{\partial P}{\partial \nu} \right)_{T} d\nu = \frac{RdT}{\nu} - \frac{RTd\nu}{\nu^2}$$

(a) The change in T can be expressed as $dT \cong \Delta T = 350 \times 0.01 = 3.5 \text{ K}$. At $\nu = \text{constant}$,

$$(dP)_{\nu} = \frac{RdT}{\nu} = \frac{(0.287 \text{ kPa} \cdot \text{m}^3/\text{kg} \cdot \text{K})(3.5 \text{ K})}{0.75 \text{ m}^3/\text{kg}} = \mathbf{1.339 \text{ kPa}}$$

(b) The change in ν can be expressed as $d\nu \cong \Delta \nu = 0.75 \times 0.01 = 0.0075 \text{ m}^3/\text{kg}$. At $T = \text{constant}$,

$$(dP)_T = -\frac{RTd\nu}{\nu^2} = -\frac{(0.287 \text{ kPa} \cdot \text{m}^3/\text{kg} \cdot \text{K})(300 \text{ K})(0.0075 \text{ m}^3/\text{kg})}{(0.75 \text{ m}^3/\text{kg})^2} = \mathbf{-1.339 \text{ kPa}}$$

(c) When both ν and T increases by 1%, the change in P becomes

$$dP = (dP)_{\nu} + (dP)_T = 1.339 + (-1.339) = \mathbf{0}$$

Thus the changes in T and ν balance each other.

12-6 Helium at a specified temperature and specific volume is considered. The changes in pressure corresponding to a certain increase of different properties are to be determined.

Assumptions Helium is an ideal gas

Properties The gas constant of helium is $R = 2.0769 \text{ kPa} \cdot \text{m}^3/\text{kg} \cdot \text{K}$ (Table A-1).

Analysis An ideal gas equation can be expressed as $P = RT/\nu$. Noting that R is a constant and $P = P(T, \nu)$,

$$dP = \left(\frac{\partial P}{\partial T} \right)_{\nu} dT + \left(\frac{\partial P}{\partial \nu} \right)_{T} d\nu = \frac{RdT}{\nu} - \frac{RTd\nu}{\nu^2}$$

(a) The change in T can be expressed as $dT \cong \Delta T = 350 \times 0.01 = 3.5 \text{ K}$. At $\nu = \text{constant}$,

$$(dP)_{\nu} = \frac{RdT}{\nu} = \frac{(2.0769 \text{ kPa} \cdot \text{m}^3/\text{kg} \cdot \text{K})(3.5 \text{ K})}{0.75 \text{ m}^3/\text{kg}} = \mathbf{9.692 \text{ kPa}}$$

(b) The change in ν can be expressed as $d\nu \cong \Delta \nu = 0.75 \times 0.01 = 0.0075 \text{ m}^3/\text{kg}$. At $T = \text{constant}$,

$$(dP)_{T} = -\frac{RTd\nu}{\nu^2} = \frac{(2.0769 \text{ kPa} \cdot \text{m}^3/\text{kg} \cdot \text{K})(300 \text{ K})(0.0075 \text{ m}^3)}{(0.75 \text{ m}^3/\text{kg})^2} = \mathbf{-9.692 \text{ kPa}}$$

(c) When both ν and T increases by 1%, the change in P becomes

$$dP = (dP)_{\nu} + (dP)_{T} = 9.692 + (-9.692) = \mathbf{0}$$

Thus the changes in T and ν balance each other.

12-7 Nitrogen gas at a specified state is considered. The c_p and c_v of the nitrogen are to be determined using Table A-18, and to be compared to the values listed in Table A-2b.

Analysis The c_p and c_v of ideal gases depends on temperature only, and are expressed as $c_p(T) = dh(T)/dT$ and $c_v(T) = du(T)/dT$. Approximating the differentials as differences about 400 K, the c_p and c_v values are determined to be

$$\begin{aligned} c_p(400 \text{ K}) &= \left(\frac{dh(T)}{dT} \right)_{T=400 \text{ K}} \cong \left(\frac{\Delta h(T)}{\Delta T} \right)_{T \cong 400 \text{ K}} \\ &= \frac{h(410 \text{ K}) - h(390 \text{ K})}{(410 - 390) \text{ K}} \\ &= \frac{(11,932 - 11,347) \text{ kJ/kg}}{(410 - 390) \text{ K}} \\ &= \mathbf{1.045 \text{ kJ/kg} \cdot \text{K}} \end{aligned}$$

(Compare: Table A-2b at 400 K $\rightarrow c_p = 1.044 \text{ kJ/kg} \cdot \text{K}$)

$$\begin{aligned} c_v(400 \text{ K}) &= \left(\frac{du(T)}{dT} \right)_{T=400 \text{ K}} \cong \left(\frac{\Delta u(T)}{\Delta T} \right)_{T \cong 400 \text{ K}} \\ &= \frac{u(410 \text{ K}) - u(390 \text{ K})}{(410 - 390) \text{ K}} \\ &= \frac{(8,523 - 8,104) \text{ kJ/kg}}{(410 - 390) \text{ K}} = \mathbf{0.748 \text{ kJ/kg} \cdot \text{K}} \end{aligned}$$

(Compare: Table A-2b at 400 K $\rightarrow c_v = 0.747 \text{ kJ/kg} \cdot \text{K}$)

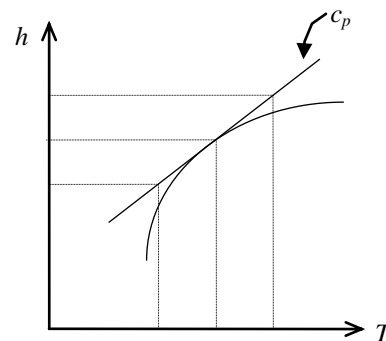

12-8E Nitrogen gas at a specified state is considered. The c_p and c_v of the nitrogen are to be determined using Table A-18E, and to be compared to the values listed in Table A-2Eb.

Analysis The c_p and c_v of ideal gases depends on temperature only, and are expressed as $c_p(T) = dh(T)/dT$ and $c_v(T) = du(T)/dT$. Approximating the differentials as differences about 600 R, the c_p and c_v values are determined to be

$$\begin{aligned} c_p(800 \text{ R}) &= \left(\frac{dh(T)}{dT} \right)_{T=800 \text{ R}} \cong \left(\frac{\Delta h(T)}{\Delta T} \right)_{T \cong 800 \text{ R}} \\ &= \frac{h(820 \text{ R}) - h(780 \text{ R})}{(820 - 780) \text{ R}} \\ &= \frac{(5704.7 - 5424.2)/28.013 \text{ Btu/lbm}}{(820 - 780) \text{ R}} = \mathbf{0.250 \text{ Btu/lbm} \cdot \text{R}} \end{aligned}$$

(Compare: Table A-2Eb at 800 R = 340°F → $c_p = 0.250 \text{ Btu/lbm} \cdot \text{R}$)

$$\begin{aligned} c_v(800 \text{ R}) &= \left(\frac{du(T)}{dT} \right)_{T=800 \text{ R}} \cong \left(\frac{\Delta u(T)}{\Delta T} \right)_{T \cong 800 \text{ R}} \\ &= \frac{u(820 \text{ R}) - u(780 \text{ R})}{(820 - 780) \text{ R}} \\ &= \frac{(4076.3 - 3875.2)/28.013 \text{ Btu/lbm}}{(820 - 780) \text{ R}} = \mathbf{0.179 \text{ Btu/lbm} \cdot \text{R}} \end{aligned}$$

(Compare: Table A-2Eb at 800 R = 340°F → $c_v = 0.179 \text{ Btu/lbm} \cdot \text{R}$)

12-9 The state of an ideal gas is altered slightly. The change in the specific volume of the gas is to be determined using differential relations and the ideal-gas relation at each state.

Assumptions The gas is air and air is an ideal gas.

Properties The gas constant of air is $R = 0.287 \text{ kPa} \cdot \text{m}^3/\text{kg} \cdot \text{K}$ (Table A-1).

Analysis (a) The changes in T and P can be expressed as

$$dT \cong \Delta T = (305 - 300)\text{K} = 5 \text{ K}$$

$$dP \cong \Delta P = (96 - 100)\text{kPa} = -4 \text{ kPa}$$

The ideal gas relation $P\nu = RT$ can be expressed as $\nu = RT/P$. Note that R is a constant and $\nu = \nu(T, P)$. Applying the total differential relation and using average values for T and P ,

$$\begin{aligned} d\nu &= \left(\frac{\partial \nu}{\partial T} \right)_P dT + \left(\frac{\partial \nu}{\partial P} \right)_T dP = \frac{RdT}{P} - \frac{RTdP}{P^2} \\ &= (0.287 \text{ kPa} \cdot \text{m}^3/\text{kg} \cdot \text{K}) \left(\frac{5 \text{ K}}{98 \text{ kPa}} - \frac{(302.5 \text{ K})(-4 \text{ kPa})}{(98 \text{ kPa})^2} \right) \\ &= (0.01464 \text{ m}^3/\text{kg}) + (0.03616 \text{ m}^3/\text{kg}) \\ &= \mathbf{0.0508 \text{ m}^3/\text{kg}} \end{aligned}$$

(b) Using the ideal gas relation at each state,

$$\begin{aligned} \nu_1 &= \frac{RT_1}{P_1} = \frac{(0.287 \text{ kPa} \cdot \text{m}^3/\text{kg} \cdot \text{K})(300 \text{ K})}{100 \text{ kPa}} = 0.8610 \text{ m}^3/\text{kg} \\ \nu_2 &= \frac{RT_2}{P_2} = \frac{(0.287 \text{ kPa} \cdot \text{m}^3/\text{kg} \cdot \text{K})(305 \text{ K})}{96 \text{ kPa}} = 0.9118 \text{ m}^3/\text{kg} \end{aligned}$$

Thus,

$$\Delta \nu = \nu_2 - \nu_1 = 0.9118 - 0.8610 = \mathbf{0.0508 \text{ m}^3/\text{kg}}$$

The two results are identical.

12-10 Using the equation of state $P(\nu - a) = RT$, the cyclic relation, and the reciprocity relation at constant ν are to be verified.

Analysis (a) This equation of state involves three variables P , ν , and T . Any two of these can be taken as the independent variables, with the remaining one being the dependent variable. Replacing x , y , and z by P , ν , and T , the cyclic relation can be expressed as

$$\left(\frac{\partial P}{\partial \nu}\right)_T \left(\frac{\partial \nu}{\partial T}\right)_P \left(\frac{\partial T}{\partial P}\right)_\nu = -1$$

where

$$\begin{aligned} P = \frac{RT}{\nu - a} &\longrightarrow \left(\frac{\partial P}{\partial \nu}\right)_T = \frac{-RT}{(\nu - a)^2} = -\frac{P}{\nu - a} \\ \nu = \frac{RT}{P} + a &\longrightarrow \left(\frac{\partial \nu}{\partial T}\right)_P = \frac{R}{P} \\ T = \frac{P(\nu - a)}{R} &\longrightarrow \left(\frac{\partial T}{\partial P}\right)_\nu = \frac{\nu - a}{R} \end{aligned}$$

Substituting,

$$\left(\frac{\partial P}{\partial \nu}\right)_T \left(\frac{\partial \nu}{\partial T}\right)_P \left(\frac{\partial T}{\partial P}\right)_\nu = \left(-\frac{P}{\nu - a}\right) \left(\frac{R}{P}\right) \left(\frac{\nu - a}{R}\right) = -1$$

which is the desired result.

(b) The reciprocity rule for this gas at $\nu = \text{constant}$ can be expressed as

$$\begin{aligned} \left(\frac{\partial P}{\partial T}\right)_\nu &= \frac{1}{(\partial T / \partial P)_\nu} \\ T = \frac{P(\nu - a)}{R} &\longrightarrow \left(\frac{\partial T}{\partial P}\right)_\nu = \frac{\nu - a}{R} \\ P = \frac{RT}{\nu - a} &\longrightarrow \left(\frac{\partial P}{\partial T}\right)_\nu = \frac{R}{\nu - a} \end{aligned}$$

We observe that the first differential is the inverse of the second one. Thus the proof is complete.

12-11 A relation is to be derived for the slope of the $\nu = \text{constant}$ lines on a T - P diagram for a gas that obeys the van der Waals equation of state.

Analysis The van der Waals equation of state can be expressed as

$$T = \frac{1}{R} \left(P + \frac{a}{\nu^2} \right) (\nu - b)$$

Taking the derivative of T with respect to P holding ν constant,

$$\left(\frac{\partial T}{\partial P}\right)_\nu = \frac{1}{R} (1+0)(\nu - b) = \frac{\nu - b}{R}$$

which is the slope of the $\nu = \text{constant}$ lines on a T - P diagram.

The Maxwell Relations

12-12 The validity of the last Maxwell relation for refrigerant-134a at a specified state is to be verified.

Analysis We do not have exact analytical property relations for refrigerant-134a, and thus we need to replace the differential quantities in the last Maxwell relation with the corresponding finite quantities. Using property values from the tables about the specified state,

$$\begin{aligned} \left(\frac{\partial s}{\partial p}\right)_T &\stackrel{?}{=} -\left(\frac{\partial v}{\partial T}\right)_p \\ \left(\frac{\Delta s}{\Delta p}\right)_{T=50^\circ\text{C}} &\stackrel{?}{\cong} -\left(\frac{\Delta v}{\Delta T}\right)_{p=700\text{kPa}} \\ \left(\frac{s_{900\text{kPa}} - s_{500\text{kPa}}}{(900 - 500)\text{kPa}}\right)_{T=50^\circ\text{C}} &\stackrel{?}{\cong} -\left(\frac{v_{70^\circ\text{C}} - v_{30^\circ\text{C}}}{(70 - 30)^\circ\text{C}}\right)_{p=700\text{kPa}} \\ \frac{(0.9661 - 1.0309)\text{kJ/kg} \cdot \text{K}}{(900 - 500)\text{kPa}} &\stackrel{?}{\cong} -\frac{(0.036373 - 0.029966)\text{m}^3/\text{kg}}{(70 - 30)^\circ\text{C}} \\ &= -1.621 \times 10^{-4} \text{ m}^3/\text{kg} \cdot \text{K} \cong -1.602 \times 10^{-4} \text{ m}^3/\text{kg} \cdot \text{K} \end{aligned}$$

since $\text{kJ} \equiv \text{kPa} \cdot \text{m}^3$, and $\text{K} \equiv ^\circ\text{C}$ for temperature differences. Thus the last Maxwell relation is satisfied.



12-13 Problem 12-12 is reconsidered. The validity of the last Maxwell relation for refrigerant 134a at the specified state is to be verified.

Analysis The problem is solved using EES, and the solution is given below.

"Input Data:"

```
T=50 [C]
P=700 [kPa]
P_increment = 200 [kPa]
T_increment = 20 [C]
P[2]=P+P_increment
P[1]=P-P_increment
T[2]=T+T_increment
T[1]=T-T_increment
```

```
DELTAP = P[2]-P[1]
DELTAT = T[2]-T[1]
```

```
v[1]=volume(R134a,T=T[1],P=P)
v[2]=volume(R134a,T=T[2],P=P)
s[1]=entropy(R134a,T=T,P=P[1])
s[2]=entropy(R134a,T=T,P=P[2])
```

```
DELTA_s=s[2] - s[1]
DELTA_v=v[2] - v[1]
```

"The partial derivatives in the last Maxwell relation (Eq. 12-19) is associated with the Gibbs function and are approximated by the ratio of ordinary differentials:"

```
LeftSide =DELTA_s/DELTAP*Convert(kJ,m^3-kPa) "[m^3/kg-K]" "at T = Const."
RightSide=-DELTA_v/DELTAT "[m^3/kg-K]" "at P = Const."
```

SOLUTION

```
DELTAP=400 [kPa]
DELTA_s=-0.06484 [kJ/kg-K]
DELTAT=40 [C]
DELTA_v=0.006407 [m^3/kg]
LeftSide=-0.0001621 [m^3/kg-K]
P=700 [kPa]
P[1]=500 [kPa]
P[2]=900 [kPa]
P_increment=200 [kPa]
RightSide=-0.0001602 [m^3/kg-K]
s[1]=1.0309 [kJ/kg-K]
s[2]=0.9661 [kJ/kg-K]
T=50 [C]
T[1]=30 [C]
T[2]=70 [C]
T_increment=20 [C]
v[1]=0.02997 [m^3/kg]
v[2]=0.03637 [m^3/kg]
```

12-14E The validity of the last Maxwell relation for steam at a specified state is to be verified.

Analysis We do not have exact analytical property relations for steam, and thus we need to replace the differential quantities in the last Maxwell relation with the corresponding finite quantities. Using property values from the tables about the specified state,

$$\begin{aligned} \left(\frac{\partial s}{\partial P}\right)_T &\stackrel{?}{=} -\left(\frac{\partial v}{\partial T}\right)_P \\ \left(\frac{\Delta s}{\Delta P}\right)_{T=60^\circ\text{F}} &\stackrel{?}{\cong} -\left(\frac{\Delta v}{\Delta T}\right)_{P=275\text{psia}} \\ \left(\frac{s_{300\text{psia}} - s_{250\text{psia}}}{(300 - 250)\text{psia}}\right)_{T=60^\circ\text{F}} &\stackrel{?}{\cong} -\left(\frac{v_{650^\circ\text{F}} - v_{550^\circ\text{F}}}{(650 - 550)^\circ\text{F}}\right)_{P=275\text{psia}} \\ \frac{(1.6270 - 1.6499)\text{Btu/lbm}\cdot\text{R}}{(300 - 250)\text{psia}} &\stackrel{?}{\cong} -\frac{(2.3179 - 2.0715)\text{ft}^3/\text{lbm}}{(650 - 550)^\circ\text{F}} \\ &\cong -2.466 \times 10^{-3} \text{ft}^3/\text{lbm}\cdot\text{R} \cong -2.464 \times 10^{-3} \text{ft}^3/\text{lbm}\cdot\text{R} \end{aligned}$$

since $1 \text{ Btu} = 5.4039 \text{ psia}\cdot\text{ft}^3$, and $\text{R} \equiv ^\circ\text{F}$ for temperature differences. Thus the fourth Maxwell relation is satisfied.

12-15 Using the Maxwell relations, a relation for $(\partial s/\partial P)_T$ for a gas whose equation of state is $P(v-b) = RT$ is to be obtained.

Analysis This equation of state can be expressed as $v = \frac{RT}{P} + b$. Then,

$$\left(\frac{\partial v}{\partial T}\right)_P = \frac{R}{P}$$

From the fourth Maxwell relation,

$$\left(\frac{\partial s}{\partial P}\right)_T = -\left(\frac{\partial v}{\partial T}\right)_P = -\frac{R}{P}$$

12-16 Using the Maxwell relations, a relation for $(\partial s/\partial v)_T$ for a gas whose equation of state is $(P-a/v^2)(v-b) = RT$ is to be obtained.

Analysis This equation of state can be expressed as $P = \frac{RT}{v-b} + \frac{a}{v^2}$. Then,

$$\left(\frac{\partial P}{\partial T}\right)_v = \frac{R}{v-b}$$

From the third Maxwell relation,

$$\left(\frac{\partial s}{\partial v}\right)_T = \left(\frac{\partial P}{\partial T}\right)_v = \frac{R}{v-b}$$

12-17 Using the Maxwell relations and the ideal-gas equation of state, a relation for $(\partial s/\partial v)_T$ for an ideal gas is to be obtained.

Analysis The ideal gas equation of state can be expressed as $P = \frac{RT}{v}$. Then,

$$\left(\frac{\partial P}{\partial T}\right)_v = \frac{R}{v}$$

From the third Maxwell relation,

$$\left(\frac{\partial s}{\partial v}\right)_T = \left(\frac{\partial P}{\partial T}\right)_v = \frac{R}{v}$$

12-18 It is to be proven that $\left(\frac{\partial P}{\partial T}\right)_s = \frac{k}{k-1} \left(\frac{\partial P}{\partial T}\right)_v$

Analysis Using the definition of c_v ,

$$c_v = T \left(\frac{\partial s}{\partial T}\right)_v = T \left(\frac{\partial s}{\partial P}\right)_v \left(\frac{\partial P}{\partial T}\right)_v$$

Substituting the first Maxwell relation $\left(\frac{\partial s}{\partial P}\right)_v = -\left(\frac{\partial v}{\partial T}\right)_s$,

$$c_v = -T \left(\frac{\partial v}{\partial T}\right)_s \left(\frac{\partial P}{\partial T}\right)_v$$

Using the definition of c_p ,

$$c_p = T \left(\frac{\partial s}{\partial T}\right)_p = T \left(\frac{\partial s}{\partial v}\right)_p \left(\frac{\partial v}{\partial T}\right)_p$$

Substituting the second Maxwell relation $\left(\frac{\partial s}{\partial v}\right)_p = \left(\frac{\partial P}{\partial T}\right)_s$,

$$c_p = T \left(\frac{\partial P}{\partial T}\right)_s \left(\frac{\partial v}{\partial T}\right)_p$$

From Eq. 12-46,

$$c_p - c_v = -T \left(\frac{\partial v}{\partial T}\right)_p^2 \left(\frac{\partial P}{\partial v}\right)_T$$

Also,

$$\frac{k}{k-1} = \frac{c_p}{c_p - c_v}$$

Then,

$$\frac{k}{k-1} = -\frac{\left(\frac{\partial P}{\partial T}\right)_s \left(\frac{\partial v}{\partial T}\right)_p}{\left(\frac{\partial v}{\partial T}\right)_p^2 \left(\frac{\partial P}{\partial v}\right)_T} = -\left(\frac{\partial P}{\partial T}\right)_s \left(\frac{\partial T}{\partial v}\right)_p \left(\frac{\partial v}{\partial P}\right)_T$$

Substituting this into the original equation in the problem statement produces

$$\left(\frac{\partial P}{\partial T}\right)_s = -\left(\frac{\partial P}{\partial T}\right)_s \left(\frac{\partial T}{\partial v}\right)_p \left(\frac{\partial v}{\partial P}\right)_T \left(\frac{\partial P}{\partial T}\right)_v$$

But, according to the cyclic relation, the last three terms are equal to -1 . Then,

$$\left(\frac{\partial P}{\partial T}\right)_s = \left(\frac{\partial P}{\partial T}\right)_s$$

The Clapeyron Equation

12-19C It enables us to determine the enthalpy of vaporization from h_{fg} at a given temperature from the P, v, T data alone.

12-20C It is exact.

12-21 Using the Clapeyron equation, the enthalpy of vaporization of refrigerant-134a at a specified temperature is to be estimated and to be compared to the tabulated data.

Analysis From the Clapeyron equation,

$$\begin{aligned}
 h_{fg} &= T \nu_{fg} \left(\frac{dP}{dT} \right)_{\text{sat}} \\
 &\cong T (\nu_g - \nu_f)_{@40^\circ\text{C}} \left(\frac{\Delta P}{\Delta T} \right)_{\text{sat}, 40^\circ\text{C}} \\
 &= T (\nu_g - \nu_f)_{@40^\circ\text{C}} \left(\frac{P_{\text{sat}@42^\circ\text{C}} - P_{\text{sat}@38^\circ\text{C}}}{42^\circ\text{C} - 38^\circ\text{C}} \right) \\
 &= (40 + 273.15 \text{ K})(0.019968 - 0.0008720 \text{ m}^3/\text{kg}) \left(\frac{(1072.8 - 963.68) \text{ kPa}}{4 \text{ K}} \right) \\
 &= \mathbf{163.13 \text{ kJ/kg}}
 \end{aligned}$$

The tabulated value of h_{fg} at 40°C is **163.03 kJ/kg**.



12-22 Problem 12-21 is reconsidered. The enthalpy of vaporization of refrigerant 134-a as a function of temperature over the temperature range -20 to 80°C by using the Clapeyron equation and the refrigerant 134-a data in EES is to be plotted.

Analysis The problem is solved using EES, and the results are tabulated and plotted below.

"Input Data:"

```
T=30 [C]
T_increment = 5 [C]

T[2]=T+T_increment
T[1]=T-T_increment
P[1] = pressure(R134a,T=T[1],x=0)
P[2] = pressure(R134a,T=T[2],x=0)
DELTAP = P[2]-P[1]
DELTAT = T[2]-T[1]
```

```
v_f=volume(R134a,T=T,x=0)
v_g=volume(R134a,T=T,x=1)
h_f=enthalpy(R134a,T=T,x=0)
h_g=enthalpy(R134a,T=T,x=1)
```

```
h_fg=h_g - h_f
v_fg=v_g - v_f
```

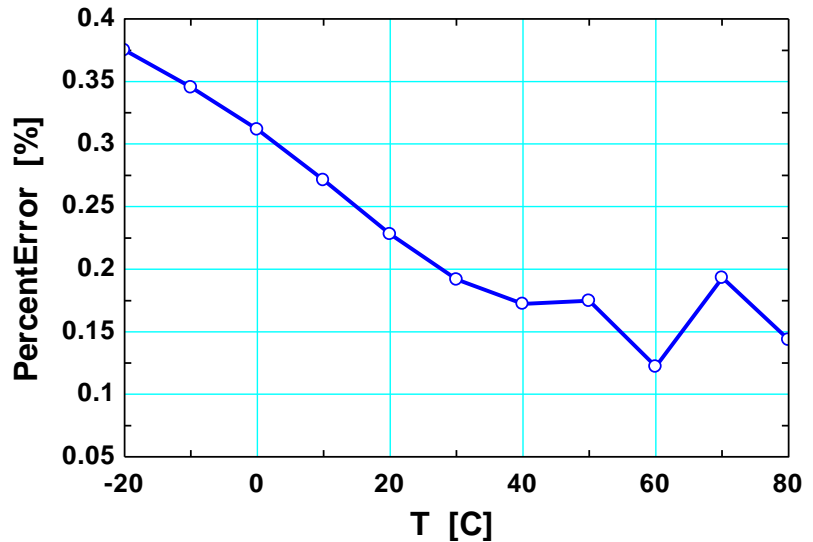

"The Clapeyron equation (Eq. 12-22) provides a means to calculate the enthalpy of vaporization, h_{fg} at a given temperature by determining the slope of the saturation curve on a P-T diagram and the specific volume of the saturated liquid and saturated vapor at the temperature."

```
h_fg_Clapeyron=(T+273.2)*v_fg*DELTAP/DELTAT*Convert(m^3-kPa,kJ)
PercentError=ABS(h_fg_Clapeyron-h_fg)/h_fg*Convert(, %) "[%]"
```

T [C]	h_{fg} [kJ/kg]	$h_{fg,Clapeyron}$ [kJ/kg]	PercentError [%]
-20	212.96	213.76	0.3752
-10	206.02	206.73	0.3454
0	198.67	199.28	0.3118
10	190.80	191.32	0.2711
20	182.33	182.74	0.228
30	173.13	173.46	0.1917
40	163.03	163.31	0.1724
50	151.82	152.08	0.1748
60	139.09	139.26	0.1222
70	124.37	124.61	0.1931
80	106.35	106.51	0.1437

12-23 Using the Clapeyron equation, the enthalpy of vaporization of steam at a specified pressure is to be estimated and to be compared to the tabulated data.

Analysis From the Clapeyron equation,

$$\begin{aligned}
 h_{fg} &= T \nu_{fg} \left(\frac{dP}{dT} \right)_{\text{sat}} \\
 &\cong T(\nu_g - \nu_f)_{@300 \text{ kPa}} \left(\frac{\Delta P}{\Delta T} \right)_{\text{sat}, 300 \text{ kPa}} \\
 &= T_{\text{sat}@300 \text{ kPa}} (\nu_g - \nu_f)_{@300 \text{ kPa}} \left(\frac{(325 - 275) \text{ kPa}}{T_{\text{sat}@325 \text{ kPa}} - T_{\text{sat}@275 \text{ kPa}}} \right) \\
 &= (133.52 + 273.15 \text{ K})(0.60582 - 0.001073 \text{ m}^3/\text{kg}) \left(\frac{50 \text{ kPa}}{(136.27 - 130.58)^\circ\text{C}} \right) \\
 &= \mathbf{2159.9 \text{ kJ/kg}}
 \end{aligned}$$

The tabulated value of h_{fg} at 300 kPa is **2163.5 kJ/kg**.

12-24E  The h_{fg} of refrigerant-134a at a specified temperature is to be calculated using the Clapeyron equation and Clapeyron-Clausius equation and to be compared to the tabulated data.

Analysis (a) From the Clapeyron equation,

$$\begin{aligned}
 h_{fg} &= T \nu_{fg} \left(\frac{dP}{dT} \right)_{\text{sat}} \\
 &\cong T(\nu_g - \nu_f)_{@10^\circ\text{F}} \left(\frac{\Delta P}{\Delta T} \right)_{\text{sat}, 10^\circ\text{F}} \\
 &= T(\nu_g - \nu_f)_{@10^\circ\text{F}} \left(\frac{P_{\text{sat}@15^\circ\text{F}} - P_{\text{sat}@5^\circ\text{F}}}{15^\circ\text{F} - 5^\circ\text{F}} \right) \\
 &= (10 + 459.67 \text{ R})(1.7358 - 0.01200 \text{ ft}^3/\text{lbm}) \left(\frac{(29.759 - 23.793) \text{ psia}}{10 \text{ R}} \right) \\
 &= 483.0 \text{ psia} \cdot \text{ft}^3/\text{lbm} = \mathbf{89.38 \text{ Btu/lbm}} \quad (0.1\% \text{ error})
 \end{aligned}$$

since $1 \text{ Btu} = 5.4039 \text{ psia} \cdot \text{ft}^3$.

(b) From the Clapeyron-Clausius equation,

$$\begin{aligned}
 \ln \left(\frac{P_2}{P_1} \right)_{\text{sat}} &\cong \frac{h_{fg}}{R} \left(\frac{1}{T_1} - \frac{1}{T_2} \right)_{\text{sat}} \\
 \ln \left(\frac{23.793 \text{ psia}}{29.759 \text{ psia}} \right) &\cong \frac{h_{fg}}{0.01946 \text{ Btu/lbm} \cdot \text{R}} \left(\frac{1}{15 + 459.67 \text{ R}} - \frac{1}{5 + 459.67 \text{ R}} \right) \\
 h_{fg} &= \mathbf{96.04 \text{ Btu/lbm}} \quad (7.6\% \text{ error})
 \end{aligned}$$

The tabulated value of h_{fg} at 10°F is **89.25 Btu/lbm**.

12-25E A substance is cooled in a piston-cylinder device until it turns from saturated vapor to saturated liquid at a constant pressure and temperature. The boiling temperature of this substance at a different pressure is to be estimated.

Analysis From the Clapeyron equation,

$$\left(\frac{dP}{dT}\right)_{\text{sat}} = \frac{h_{fg}}{T\nu_{fg}} = \frac{(250 \text{ Btu})\left(\frac{5.404 \text{ psia} \cdot \text{ft}^3}{1 \text{ Btu}}\right)/(0.5 \text{ lbm})}{(475 \text{ R})(1.5 \text{ ft}^3)/(0.5 \text{ lbm})} = 1.896 \text{ psia/R}$$

Using the finite difference approximation,

$$\left(\frac{dP}{dT}\right)_{\text{sat}} \approx \left(\frac{P_2 - P_1}{T_2 - T_1}\right)_{\text{sat}}$$

Solving for T_2 ,

$$T_2 = T_1 + \frac{P_2 - P_1}{dP/dT} = 475 \text{ R} + \frac{(60 - 50) \text{ psia}}{1.896 \text{ psia/R}} = \mathbf{480.3 \text{ R}}$$

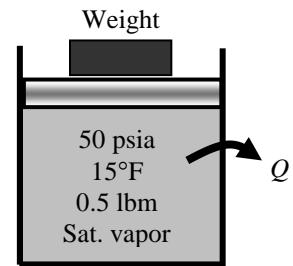

12-26E A substance is cooled in a piston-cylinder device until it turns from saturated vapor to saturated liquid at a constant pressure and temperature. The saturation pressure of this substance at a different temperature is to be estimated.

Analysis From the Clapeyron equation,

$$\left(\frac{dP}{dT}\right)_{\text{sat}} = \frac{h_{fg}}{T\nu_{fg}} = \frac{(250 \text{ Btu})\left(\frac{5.404 \text{ psia} \cdot \text{ft}^3}{1 \text{ Btu}}\right)/(0.5 \text{ lbm})}{(475 \text{ R})(1.5 \text{ ft}^3)/(0.5 \text{ lbm})} = 1.896 \text{ psia/R}$$

Using the finite difference approximation,

$$\left(\frac{dP}{dT}\right)_{\text{sat}} \approx \left(\frac{P_2 - P_1}{T_2 - T_1}\right)_{\text{sat}}$$

Solving for P_2 ,

$$P_2 = P_1 + \frac{dP}{dT}(T_2 - T_1) = 50 \text{ psia} + (1.896 \text{ psia/R})(480 - 475) \text{ R} = \mathbf{59.5 \text{ psia}}$$

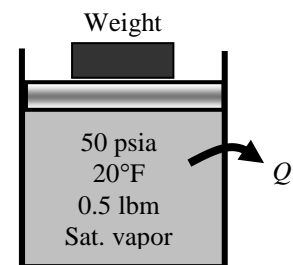

12-27E A substance is cooled in a piston-cylinder device until it turns from saturated vapor to saturated liquid at a constant pressure and temperature. The s_{fg} of this substance at the given temperature is to be estimated.

Analysis From the Clapeyron equation,

$$\left(\frac{dP}{dT}\right)_{\text{sat}} = \frac{h_{fg}}{T\nu_{fg}} = \frac{s_{fg}}{\nu_{fg}}$$

Solving for s_{fg} ,

$$s_{fg} = \frac{h_{fg}}{T} = \frac{(250 \text{ Btu})/(0.5 \text{ lbm})}{475 \text{ R}} = \mathbf{1.053 \text{ Btu/lbm} \cdot \text{R}}$$

Alternatively,

$$s_{fg} = \left(\frac{dP}{dT}\right)_{\text{sat}} \nu_{fg} = (1.896 \text{ psia/R}) \frac{1.5 \text{ ft}^3}{0.5 \text{ lbm}} \left(\frac{1 \text{ Btu}}{5.404 \text{ psia} \cdot \text{ft}^3}\right) = 1.053 \text{ Btu/lbm} \cdot \text{R}$$

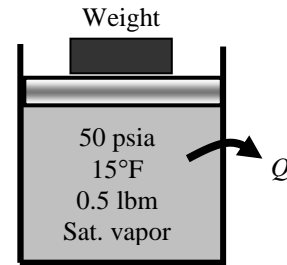

12-28E A table of properties for methyl chloride is given. The saturation pressure is to be estimated at two different temperatures.

Analysis The Clapeyron equation is

$$\left(\frac{dP}{dT}\right)_{\text{sat}} = \frac{h_{fg}}{T\nu_{fg}}$$

Using the finite difference approximation,

$$\left(\frac{dP}{dT}\right)_{\text{sat}} \approx \left(\frac{P_2 - P_1}{T_2 - T_1}\right)_{\text{sat}} = \frac{h_{fg}}{T\nu_{fg}}$$

Solving this for the second pressure gives for $T_2 = 110^\circ\text{F}$

$$\begin{aligned} P_2 &= P_1 + \frac{h_{fg}}{T\nu_{fg}}(T_2 - T_1) \\ &= 116.7 \text{ psia} + \frac{154.85 \text{ Btu/lbm}}{(560 \text{ R})(0.86332 \text{ ft}^3/\text{lbm})} \left(\frac{5.404 \text{ psia} \cdot \text{ft}^3}{1 \text{ Btu}}\right) (110 - 100)\text{R} \\ &= \mathbf{134.0 \text{ psia}} \end{aligned}$$

When $T_2 = 90^\circ\text{F}$

$$\begin{aligned} P_2 &= P_1 + \frac{h_{fg}}{T\nu_{fg}}(T_2 - T_1) \\ &= 116.7 \text{ psia} + \frac{154.85 \text{ Btu/lbm}}{(560 \text{ R})(0.86332 \text{ ft}^3/\text{lbm})} \left(\frac{5.404 \text{ psia} \cdot \text{ft}^3}{1 \text{ Btu}}\right) (90 - 100)\text{R} \\ &= \mathbf{99.4 \text{ psia}} \end{aligned}$$

12-29 The sublimation pressure of water at -30°C is to be determined using Clapeyron-Clasius equation and the triple point data of water.

Analysis The sublimation pressure may be determined using Clapeyron-Clasius equation from

$$\ln\left(\frac{P_{\text{sub,CC}}}{P_1}\right) = \frac{h_{ig}}{R} \left(\frac{1}{T_1} - \frac{1}{T_2}\right)$$

where the triple point properties of water are $P_1 = 0.6117 \text{ kPa}$ and $T_1 = 0.01^{\circ}\text{C} = 273.16 \text{ K}$ (first line in Table A-4). Also, the enthalpy of sublimation of water at -30°C is determined from Table A-8 to be 2838.4 kJ/kg . Substituting,

$$\ln\left(\frac{P_{\text{sub,CC}}}{P_1}\right) = \frac{h_{ig}}{R} \left(\frac{1}{T_1} - \frac{1}{T_2}\right)$$

$$\ln\left(\frac{P_{\text{sub,CC}}}{0.6117 \text{ kPa}}\right) = \frac{2838.4 \text{ kJ/kg}}{0.4615 \text{ kJ/kg}\cdot\text{K}} \left(\frac{1}{273.16 \text{ K}} - \frac{1}{-30 + 273.15 \text{ K}}\right)$$

$$P_{\text{sub,CC}} = \mathbf{0.03799 \text{ kPa}}$$

The sublimation pressure of water at -30°C is given in Table A-8 to be 0.03802 kPa . Then, the error involved in using Clapeyron-Clasius equation becomes

$$\text{PercentError} = \frac{0.03802 - 0.03799}{0.03802} \times 100 = \mathbf{0.08\%}$$

12-30 It is to be shown that $c_{p,g} - c_{p,f} = T \left(\frac{\partial(h_{fg}/T)}{\partial T} \right)_P + \nu_{fg} \left(\frac{\partial P}{\partial T} \right)_{\text{sat}}$.

Analysis The definition of specific heat and Clapeyron equation are

$$c_p = \left(\frac{\partial h}{\partial T} \right)_P$$

$$\left(\frac{dP}{dT} \right)_{\text{sat}} = \frac{h_{fg}}{T \nu_{fg}}$$

According to the definition of the enthalpy of vaporization,

$$\frac{h_{fg}}{T} = \frac{h_g}{T} - \frac{h_f}{T}$$

Differentiating this expression gives

$$\begin{aligned} \left(\frac{\partial h_{fg}/T}{\partial T} \right)_P &= \left(\frac{\partial h_g/T}{\partial T} \right)_P - \left(\frac{\partial h_f/T}{\partial T} \right)_P \\ &= \frac{1}{T} \left(\frac{\partial h_g}{\partial T} \right)_P - \frac{h_g}{T^2} - \frac{1}{T} \left(\frac{\partial h_f}{\partial T} \right)_P + \frac{h_f}{T^2} \\ &= \frac{c_{p,g}}{T} - \frac{c_{p,f}}{T} - \frac{h_g - h_f}{T^2} \end{aligned}$$

Using Clapeyron to replace the last term of this expression and solving for the specific heat difference gives

$$c_{p,g} - c_{p,f} = T \left(\frac{\partial(h_{fg}/T)}{\partial T} \right)_P + \nu_{fg} \left(\frac{\partial P}{\partial T} \right)_{\text{sat}}$$

General Relations for du , dh , ds , c_v , and c_p

12-31C Yes, through the relation

$$\left(\frac{\partial c_p}{\partial P}\right)_T = -T \left(\frac{\partial^2 v}{\partial T^2}\right)_P$$

12-32 The volume expansivity β and the isothermal compressibility α of refrigerant-134a at 200 kPa and 30°C are to be estimated.

Analysis The volume expansivity and isothermal compressibility are expressed as

$$\beta = \frac{1}{v} \left(\frac{\partial v}{\partial T}\right)_P \quad \text{and} \quad \alpha = -\frac{1}{v} \left(\frac{\partial v}{\partial P}\right)_T$$

Approximating differentials by differences about the specified state,

$$\begin{aligned} \beta &\cong \frac{1}{v} \left(\frac{\Delta v}{\Delta T}\right)_{P=200\text{kPa}} = \frac{1}{v} \left(\frac{v_{40^\circ\text{C}} - v_{20^\circ\text{C}}}{(40 - 20)^\circ\text{C}}\right)_{P=200\text{kPa}} \\ &= \frac{1}{0.11874 \text{ m}^3/\text{kg}} \left(\frac{(0.12322 - 0.11418)\text{m}^3/\text{kg}}{20 \text{ K}}\right) \\ &= \mathbf{0.00381 \text{ K}^{-1}} \end{aligned}$$

and

$$\begin{aligned} \alpha &\cong -\frac{1}{v} \left(\frac{\Delta v}{\Delta P}\right)_{T=30^\circ\text{C}} = -\frac{1}{v} \left(\frac{v_{240\text{kPa}} - v_{180\text{kPa}}}{(240 - 180)\text{kPa}}\right)_{T=30^\circ\text{C}} \\ &= -\frac{1}{0.11874 \text{ m}^3/\text{kg}} \left(\frac{(0.09812 - 0.13248)\text{m}^3/\text{kg}}{60 \text{ kPa}}\right) \\ &= \mathbf{0.00482 \text{ kPa}^{-1}} \end{aligned}$$

12-33 The specific heat difference $c_p - c_v$ for liquid water at 15 MPa and 80°C is to be estimated.

Analysis The specific heat difference $c_p - c_v$ is given as

$$c_p - c_v = -T \left(\frac{\partial v}{\partial T} \right)_P^2 \left(\frac{\partial P}{\partial v} \right)_T$$

Approximating differentials by differences about the specified state,

$$\begin{aligned} c_p - c_v &\cong -T \left(\frac{\Delta v}{\Delta T} \right)_{P=15 \text{ MPa}}^2 \left(\frac{\Delta P}{\Delta v} \right)_{T=80^\circ\text{C}} \\ &= -(80 + 273.15 \text{ K}) \left(\frac{v_{100^\circ\text{C}} - v_{60^\circ\text{C}}}{(100 - 60)^\circ\text{C}} \right)_{P=15 \text{ MPa}}^2 \left(\frac{(20 - 10) \text{ MPa}}{v_{20 \text{ MPa}} - v_{10 \text{ MPa}}} \right)_{T=80^\circ\text{C}} \\ &= -(353.15 \text{ K}) \left(\frac{(0.0010361 - 0.0010105) \text{ m}^3/\text{kg}}{40 \text{ K}} \right)^2 \left(\frac{10,000 \text{ kPa}}{(0.0010199 - 0.0010244) \text{ m}^3/\text{kg}} \right) \\ &= 0.3192 \text{ kPa} \cdot \text{m}^3/\text{kg} \cdot \text{K} = \mathbf{0.3192 \text{ kJ/kg} \cdot \text{K}} \end{aligned}$$

12-34 The internal energy change of air between two specified states is to be compared for two equations of states.

Assumptions Constant specific heats for air can be used.

Properties For air at the average temperature $(20+300)/2=160^\circ\text{C}=433 \text{ K}$, $c_v = 0.731 \text{ kJ/kg} \cdot \text{K}$ (Table A-2b).

Analysis Solving the equation of state for P gives

$$P = \frac{RT}{v - a}$$

Then,

$$\left(\frac{\partial P}{\partial T} \right)_v = \frac{R}{v - a}$$

Using equation 12-29,

$$du = c_v dT + \left[T \left(\frac{\partial P}{\partial T} \right)_v - P \right] dv$$

Substituting,

$$\begin{aligned} du &= c_v dT + \left(\frac{RT}{v - a} - \frac{RT}{v - a} \right) dv \\ &= c_v dT \end{aligned}$$

Integrating this result between the two states with constant specific heats gives

$$u_2 - u_1 = c_v (T_2 - T_1) = (0.731 \text{ kJ/kg} \cdot \text{K})(300 - 20) \text{ K} = \mathbf{205 \text{ kJ/kg}}$$

The ideal gas model for the air gives

$$du = c_v dT$$

which gives the same answer.

12-35 The enthalpy change of air between two specified states is to be compared for two equations of states.

Assumptions Constant specific heats for air can be used.

Properties For air at the average temperature $(34+420)/2=227^\circ\text{C}=500\text{ K}$, $c_p = 1.018\text{ kJ/kg}\cdot\text{K}$ (Table A-2b).

Analysis Solving the equation of state for ν gives

$$\nu = \frac{RT}{P} + a$$

Then,

$$\left(\frac{\partial \nu}{\partial T}\right)_P = \frac{R}{P}$$

Using equation 12-35,

$$dh = c_p dT + \left[\nu - T \left(\frac{\partial \nu}{\partial T}\right)_P \right] dP$$

Substituting,

$$\begin{aligned} dh &= c_p dT + \left(\frac{RT}{P} + a - \frac{RT}{P} \right) dP \\ &= c_p dT + a dP \end{aligned}$$

Integrating this result between the two states with constant specific heats gives

$$\begin{aligned} h_2 - h_1 &= c_p (T_2 - T_1) + a(P_2 - P_1) \\ &= (1.029\text{ kJ/kg}\cdot\text{K})(420 - 34)\text{K} + (0.01\text{ m}^3/\text{kg})(800 - 100)\text{kPa} \\ &= \mathbf{404.2\text{ kJ/kg}} \end{aligned}$$

For an ideal gas,

$$dh = c_p dT$$

which when integrated gives

$$h_2 - h_1 = c_p (T_2 - T_1) = (1.029\text{ kJ/kg}\cdot\text{K})(420 - 34)\text{K} = \mathbf{397.2\text{ kJ/kg}}$$

12-36 The entropy change of air between two specified states is to be compared for two equations of states.

Assumptions Constant specific heats for air can be used.

Properties For air at the average temperature $(20+300)/2=160^\circ\text{C}=433\text{ K}$, $c_p = 1.018\text{ kJ/kg}\cdot\text{K}$ (Table A-2b) and $R = 0.287\text{ kJ/kg}\cdot\text{K}$ (Table A-1).

Analysis Solving the equation of state for ν gives

$$\nu = \frac{RT}{P} + a$$

Then,

$$\left(\frac{\partial \nu}{\partial T}\right)_P = \frac{R}{P}$$

The entropy differential is

$$\begin{aligned} ds &= c_p \frac{dT}{T} - \left(\frac{\partial \nu}{\partial T}\right)_P dP \\ &= c_p \frac{dT}{T} - R \frac{dP}{P} \end{aligned}$$

which is the same as that of an ideal gas. Integrating this result between the two states with constant specific heats gives

$$\begin{aligned} s_2 - s_1 &= c_p \ln \frac{T_2}{T_1} - R \ln \frac{P_2}{P_1} \\ &= (1.018\text{ kJ/kg}\cdot\text{K}) \ln \frac{573\text{ K}}{293\text{ K}} - (0.287\text{ kJ/kg}\cdot\text{K}) \ln \frac{600\text{ kPa}}{100\text{ kPa}} \\ &= \mathbf{0.1686\text{ kJ/kg}\cdot\text{K}} \end{aligned}$$

12-37 The internal energy change of helium between two specified states is to be compared for two equations of states.

Properties For helium, $c_v = 3.1156 \text{ kJ/kg}\cdot\text{K}$ (Table A-2a).

Analysis Solving the equation of state for P gives

$$P = \frac{RT}{v - a}$$

Then,

$$\left(\frac{\partial P}{\partial T}\right)_v = \frac{R}{v - a}$$

Using equation 12-29,

$$du = c_v dT + \left[T \left(\frac{\partial P}{\partial T}\right)_v - P \right] dv$$

Substituting,

$$\begin{aligned} du &= c_v dT + \left(\frac{RT}{v - a} - \frac{RT}{v - a} \right) dv \\ &= c_v dT \end{aligned}$$

Integrating this result between the two states gives

$$u_2 - u_1 = c_v (T_2 - T_1) = (3.1156 \text{ kJ/kg}\cdot\text{K})(300 - 20)\text{K} = \mathbf{872.4 \text{ kJ/kg}}$$

The ideal gas model for the helium gives

$$du = c_v dT$$

which gives the same answer.

12-38 The enthalpy change of helium between two specified states is to be compared for two equations of states.

Properties For helium, $c_p = 5.1926 \text{ kJ/kg}\cdot\text{K}$ (Table A-2a).

Analysis Solving the equation of state for ν gives

$$\nu = \frac{RT}{P} + a$$

Then,

$$\left(\frac{\partial \nu}{\partial T}\right)_P = \frac{R}{P}$$

Using equation 12-35,

$$dh = c_p dT + \left[\nu - T \left(\frac{\partial \nu}{\partial T}\right)_P \right] dP$$

Substituting,

$$\begin{aligned} dh &= c_p dT + \left(\frac{RT}{P} + a - \frac{RT}{P} \right) dP \\ &= c_p dT + a dP \end{aligned}$$

Integrating this result between the two states gives

$$\begin{aligned} h_2 - h_1 &= c_p (T_2 - T_1) + a(P_2 - P_1) \\ &= (5.1926 \text{ kJ/kg}\cdot\text{K})(380 - 20)\text{K} + (0.01 \text{ m}^3/\text{kg})(750 - 150)\text{kPa} \\ &= \mathbf{1875 \text{ kJ/kg}} \end{aligned}$$

For an ideal gas,

$$dh = c_p dT$$

which when integrated gives

$$h_2 - h_1 = c_p (T_2 - T_1) = (5.1926 \text{ kJ/kg}\cdot\text{K})(380 - 20)\text{K} = \mathbf{1869 \text{ kJ/kg}}$$

12-39 The entropy change of helium between two specified states is to be compared for two equations of states.

Properties For helium, $c_p = 5.1926 \text{ kJ/kg}\cdot\text{K}$ and $R = 2.0769 \text{ kJ/kg}\cdot\text{K}$ (Table A-2a).

Analysis Solving the equation of state for ν gives

$$\nu = \frac{RT}{P} + a$$

Then,

$$\left(\frac{\partial \nu}{\partial T}\right)_P = \frac{R}{P}$$

The entropy differential is

$$\begin{aligned} ds &= c_p \frac{dT}{T} - \left(\frac{\partial \nu}{\partial T}\right)_P dP \\ &= c_p \frac{dT}{T} - R \frac{dP}{P} \end{aligned}$$

which is the same as that of an ideal gas. Integrating this result between the two states gives

$$\begin{aligned} s_2 - s_1 &= c_p \ln \frac{T_2}{T_1} - R \ln \frac{P_2}{P_1} \\ &= (5.1926 \text{ kJ/kg}\cdot\text{K}) \ln \frac{573 \text{ K}}{293 \text{ K}} - (2.0769 \text{ kJ/kg}\cdot\text{K}) \ln \frac{600 \text{ kPa}}{100 \text{ kPa}} \\ &= \mathbf{-0.2386 \text{ kJ/kg}\cdot\text{K}} \end{aligned}$$

12-40 General expressions for Δu , Δh , and Δs for a gas whose equation of state is $P(\nu - a) = RT$ for an isothermal process are to be derived.

Analysis (a) A relation for Δu is obtained from the general relation

$$\Delta u = u_2 - u_1 = \int_{T_1}^{T_2} c_\nu dT + \int_{\nu_1}^{\nu_2} \left(T \left(\frac{\partial P}{\partial T} \right)_\nu - P \right) d\nu$$

The equation of state for the specified gas can be expressed as

$$P = \frac{RT}{\nu - a} \longrightarrow \left(\frac{\partial P}{\partial T} \right)_\nu = \frac{R}{\nu - a}$$

Thus,

$$T \left(\frac{\partial P}{\partial T} \right)_\nu - P = \frac{RT}{\nu - a} - P = P - P = 0$$

Substituting,

$$\Delta u = \int_{T_1}^{T_2} c_\nu dT$$

(b) A relation for Δh is obtained from the general relation

$$\Delta h = h_2 - h_1 = \int_{T_1}^{T_2} c_p dT + \int_{P_1}^{P_2} \left(\nu - T \left(\frac{\partial \nu}{\partial T} \right)_P \right) dP$$

The equation of state for the specified gas can be expressed as

$$\nu = \frac{RT}{P} + a \longrightarrow \left(\frac{\partial \nu}{\partial T} \right)_P = \frac{R}{P}$$

Thus,

$$\nu - T \left(\frac{\partial \nu}{\partial T} \right)_P = \nu - T \frac{R}{P} = \nu - (\nu - a) = a$$

Substituting,

$$\Delta h = \int_{T_1}^{T_2} c_p dT + \int_{P_1}^{P_2} a dP = \int_{T_1}^{T_2} c_p dT + a(P_2 - P_1)$$

(c) A relation for Δs is obtained from the general relation

$$\Delta s = s_2 - s_1 = \int_{T_1}^{T_2} \frac{c_p}{T} dT - \int_{P_1}^{P_2} \left(\frac{\partial \nu}{\partial T} \right)_P dP$$

Substituting $(\partial \nu / \partial T)_P = R/T$,

$$\Delta s = \int_{T_1}^{T_2} \frac{c_p}{T} dT - \int_{P_1}^{P_2} \left(\frac{R}{P} \right)_P dP = \int_{T_1}^{T_2} \frac{c_p}{T} dT - R \ln \frac{P_2}{P_1}$$

For an isothermal process $dT = 0$ and these relations reduce to

$$\Delta u = 0, \quad \Delta h = a(P_2 - P_1), \quad \text{and} \quad \Delta s = -R \ln \frac{P_2}{P_1}$$

12-41 General expressions for Δu , Δh , and Δs for a gas that obeys the van der Waals equation of state for an isothermal process are to be derived.

Analysis (a) For an isothermal process $dT = 0$ and the general relation for Δu reduces to

$$\Delta u = u_2 - u_1 = \int_{T_1}^{T_2} c_v dT + \int_{v_1}^{v_2} \left(T \left(\frac{\partial P}{\partial T} \right)_v - P \right) dv = \int_{v_1}^{v_2} \left(T \left(\frac{\partial P}{\partial T} \right)_v - P \right) dv$$

The van der Waals equation of state can be expressed as

$$P = \frac{RT}{v-b} - \frac{a}{v^2} \longrightarrow \left(\frac{\partial P}{\partial T} \right)_v = \frac{R}{v-b}$$

Thus,

$$T \left(\frac{\partial P}{\partial T} \right)_v - P = \frac{RT}{v-b} - \frac{RT}{v-b} + \frac{a}{v^2} = \frac{a}{v^2}$$

Substituting,

$$\Delta u = \int_{v_1}^{v_2} \frac{a}{v^2} dv = a \left(\frac{1}{v_1} - \frac{1}{v_2} \right)$$

(b) The enthalpy change Δh is related to Δu through the relation

$$\Delta h = \Delta u + P_2 v_2 - P_1 v_1$$

where

$$Pv = \frac{RTv}{v-b} - \frac{a}{v}$$

Thus,

$$P_2 v_2 - P_1 v_1 = RT \left(\frac{v_2}{v_2-b} - \frac{v_1}{v_1-b} \right) + a \left(\frac{1}{v_1} - \frac{1}{v_2} \right)$$

Substituting,

$$\Delta h = 2a \left(\frac{1}{v_1} - \frac{1}{v_2} \right) + RT \left(\frac{v_2}{v_2-b} - \frac{v_1}{v_1-b} \right)$$

(c) For an isothermal process $dT = 0$ and the general relation for Δs reduces to

$$\Delta s = s_2 - s_1 = \int_{T_1}^{T_2} \frac{c_v}{T} dT + \int_{v_1}^{v_2} \left(\frac{\partial P}{\partial T} \right)_v dv = \int_{v_1}^{v_2} \left(\frac{\partial P}{\partial T} \right)_v dv$$

Substituting $(\partial P/\partial T)_v = R/(v-b)$,

$$\Delta s = \int_{v_1}^{v_2} \frac{R}{v-b} dv = R \ln \frac{v_2-b}{v_1-b}$$

12-42 Expressions for the specific heat difference $c_p - c_v$ for three substances are to be derived.

Analysis The general relation for the specific heat difference $c_p - c_v$ is

$$c_p - c_v = -T \left(\frac{\partial v}{\partial T} \right)_P^2 \left(\frac{\partial P}{\partial v} \right)_T$$

(a) For an ideal gas $Pv = RT$. Then,

$$v = \frac{RT}{P} \longrightarrow \left(\frac{\partial v}{\partial T} \right)_P = \frac{R}{P}$$

$$P = \frac{RT}{v} \longrightarrow \left(\frac{\partial P}{\partial v} \right)_T = -\frac{RT}{v^2} = -\frac{P}{v}$$

Substituting,

$$c_p - c_v = -T \left(-\frac{P}{v} \right)^2 \left(\frac{R}{P} \right) = \frac{TR}{Pv} R = R$$

(b) For a van der Waals gas $\left(P + \frac{a}{v^2} \right) (v - b) = RT$. Then,

$$T = \frac{1}{R} \left(P + \frac{a}{v^2} \right) (v - b) \longrightarrow \left(\frac{\partial T}{\partial v} \right)_P = \frac{1}{R} \left(-\frac{2a}{v^3} \right) (v - b) + \frac{1}{R} \left(P + \frac{a}{v^2} \right)$$

$$= \frac{2a(b - v)}{Rv^3} + \frac{T}{v - b}$$

Inverting,

$$\left(\frac{\partial v}{\partial T} \right)_P = \frac{1}{\frac{2a(b - v)}{Rv^3} + \frac{T}{v - b}}$$

Also,

$$P = \frac{RT}{v - b} - \frac{a}{v^2} \longrightarrow \left(\frac{\partial P}{\partial v} \right)_T = -\frac{RT}{(v - b)^2} + \frac{2a}{v^3}$$

Substituting,

$$c_p - c_v = T \left(\frac{1}{\frac{2a(b - v)}{Rv^3} + \frac{T}{v - b}} \right)^2 \left(-\frac{RT}{(v - b)^2} + \frac{2a}{v^3} \right)$$

(c) For an incompressible substance $v = \text{constant}$ and thus $(\partial v / \partial T)_P = 0$. Therefore,

$$c_p - c_v = \mathbf{0}$$

12-43 It is to be shown that $c_p - c_v = T \left(\frac{\partial P}{\partial T} \right)_v \left(\frac{\partial v}{\partial T} \right)_p$.

Analysis We begin by taking the entropy to be a function of specific volume and temperature. The differential of the entropy is then

$$ds = \left(\frac{\partial s}{\partial T} \right)_v dT + \left(\frac{\partial s}{\partial v} \right)_T dv$$

Substituting $\left(\frac{\partial s}{\partial T} \right)_v = \frac{c_v}{T}$ from Eq. 12-28 and the third Maxwell equation changes this to

$$ds = \frac{c_v}{T} dT + \left(\frac{\partial P}{\partial T} \right)_v dv$$

Taking the entropy to be a function of pressure and temperature,

$$ds = \left(\frac{\partial s}{\partial T} \right)_p dT + \left(\frac{\partial s}{\partial P} \right)_T dP$$

Combining this result with $\left(\frac{\partial s}{\partial T} \right)_p = \frac{c_p}{T}$ from Eq. 12-34 and the fourth Maxwell equation produces

$$ds = \frac{c_p}{T} dT - \left(\frac{\partial v}{\partial T} \right)_p dP$$

Equating the two previous ds expressions and solving the result for the specific heat difference,

$$(c_p - c_v)dT = T \left(\frac{\partial v}{\partial T} \right)_p dP + \left(\frac{\partial P}{\partial T} \right)_v dv$$

Taking the pressure to be a function of temperature and volume,

$$dP = \left(\frac{\partial P}{\partial T} \right)_v dT + \left(\frac{\partial P}{\partial v} \right)_T dv$$

When this is substituted into the previous expression, the result is

$$(c_p - c_v)dT = T \left(\frac{\partial v}{\partial T} \right)_p \left(\frac{\partial P}{\partial T} \right)_v dT + T \left[\left(\frac{\partial v}{\partial T} \right)_p \left(\frac{\partial P}{\partial v} \right)_T \left(\frac{\partial P}{\partial T} \right)_v \right] dv$$

According to the cyclic relation, the term in the bracket is zero. Then, canceling the common dT term,

$$c_p - c_v = T \left(\frac{\partial P}{\partial T} \right)_v \left(\frac{\partial v}{\partial T} \right)_p$$

12-44 It is to be proven that the definition for temperature $T = (\partial u / \partial s)_v$ reduces the net entropy change of two constant-volume systems filled with simple compressible substances to zero as the two systems approach thermal equilibrium.

Analysis The two constant-volume systems form an isolated system shown here

For the isolated system

$$dS_{\text{tot}} = dS_A + dS_B \geq 0$$

Assume $S = S(u, v)$

Then,

$$ds = \left(\frac{\partial s}{\partial u} \right)_v du + \left(\frac{\partial s}{\partial v} \right)_u dv$$

Since $v = \text{const.}$ and $dv = 0$,

$$ds = \left(\frac{\partial s}{\partial u} \right)_v du$$

and from the definition of temperature from the problem statement,

$$\frac{du}{(\partial u / \partial s)_v} = \frac{du}{T}$$

Then,

$$dS_{\text{tot}} = m_A \frac{du_A}{T_A} + m_B \frac{du_B}{T_B}$$

The first law applied to the isolated system yields

$$E_{\text{in}} - E_{\text{out}} = dU \\ 0 = dU \longrightarrow m_A du_A + m_B du_B = 0 \longrightarrow m_B du_B = -m_A du_A$$

Now, the entropy change may be expressed as

$$dS_{\text{tot}} = m_A du_A \left(\frac{1}{T_A} - \frac{1}{T_B} \right) = m_A du_A \left(\frac{T_B - T_A}{T_A T_B} \right)$$

As the two systems approach thermal equilibrium,

$$\lim dS_{\text{tot}} = 0 \\ T_A \rightarrow T_B$$

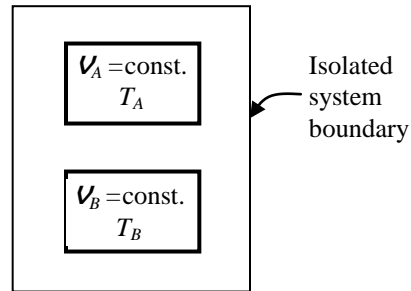

12-45 Relations for the volume expansivity β and the isothermal compressibility α for an ideal gas and for a gas whose equation of state is $P(\nu - a) = RT$ are to be obtained.

Analysis The volume expansivity and isothermal compressibility are expressed as

$$\beta = \frac{1}{\nu} \left(\frac{\partial \nu}{\partial T} \right)_P \quad \text{and} \quad \alpha = -\frac{1}{\nu} \left(\frac{\partial \nu}{\partial P} \right)_T$$

(a) For an ideal gas $\nu = RT/P$. Thus,

$$\begin{aligned} \left(\frac{\partial \nu}{\partial T} \right)_P &= \frac{R}{P} \quad \longrightarrow \quad \beta = \frac{1}{\nu} \frac{R}{P} = \frac{1}{T} \\ \left(\frac{\partial \nu}{\partial P} \right)_T &= -\frac{RT}{P^2} = -\frac{\nu}{P} \quad \longrightarrow \quad \alpha = -\frac{1}{\nu} \left(-\frac{\nu}{P} \right) = \frac{1}{P} \end{aligned}$$

(b) For a gas whose equation of state is $\nu = RT/P + a$,

$$\begin{aligned} \left(\frac{\partial \nu}{\partial T} \right)_P &= \frac{R}{P} \quad \longrightarrow \quad \beta = \frac{1}{\nu} \frac{R}{P} = \frac{R}{RT + aP} \\ \left(\frac{\partial \nu}{\partial P} \right)_T &= -\frac{RT}{P^2} = -\frac{\nu - a}{P} \quad \longrightarrow \quad \alpha = -\frac{1}{\nu} \left(-\frac{\nu - a}{P} \right) = \frac{\nu - a}{P\nu} \end{aligned}$$

12-46 An expression for the isothermal compressibility of a substance whose equation of state is $P = \frac{RT}{\nu - b} - \frac{a}{\nu(\nu + b)T^{1/2}}$

is to be derived.

Analysis The definition for the isothermal compressibility is

$$\alpha = -\frac{1}{\nu} \left(\frac{\partial \nu}{\partial P} \right)_T$$

The derivative is

$$\left(\frac{\partial P}{\partial \nu} \right)_T = -\frac{RT}{(\nu - b)^2} + \frac{a}{T^{1/2}} \frac{2\nu + b}{\nu^2(\nu + b)^2}$$

Substituting,

$$\alpha = -\frac{1}{\nu} \left(\frac{\partial \nu}{\partial P} \right)_T = -\frac{1}{\nu} \left(\frac{1}{-\frac{RT}{(\nu - b)^2} + \frac{a}{T^{1/2}} \frac{2\nu + b}{\nu^2(\nu + b)^2}} \right) = -\frac{1}{-\frac{RT\nu}{(\nu - b)^2} + \frac{a}{T^{1/2}} \frac{2\nu + b}{(\nu + b)^2}}$$

12-47 An expression for the volume expansivity of a substance whose equation of state is $P = \frac{RT}{\nu - b} - \frac{a}{\nu^2 T}$ is to be derived.

Analysis The definition for volume expansivity is

$$\beta = \frac{1}{\nu} \left(\frac{\partial \nu}{\partial T} \right)_P$$

According to the cyclic relation,

$$\left(\frac{\partial \nu}{\partial T} \right)_P \left(\frac{\partial P}{\partial \nu} \right)_T \left(\frac{\partial T}{\partial P} \right)_\nu = -1$$

which on rearrangement becomes

$$\left(\frac{\partial \nu}{\partial T} \right)_P = - \frac{\left(\frac{\partial P}{\partial T} \right)_\nu}{\left(\frac{\partial P}{\partial \nu} \right)_T}$$

Proceeding to perform the differentiations gives

$$\left(\frac{\partial P}{\partial T} \right)_\nu = \frac{R}{\nu - b} + \frac{a}{\nu^2 T^2}$$

and

$$\left(\frac{\partial P}{\partial \nu} \right)_T = - \frac{RT}{(\nu - b)^2} + \frac{2a}{\nu^3 T}$$

Substituting these results into the definition of the volume expansivity produces

$$\beta = - \frac{1}{\nu} \frac{\frac{R}{\nu - b} + \frac{a}{\nu^2 T^2}}{- \frac{RT}{(\nu - b)^2} + \frac{2a}{\nu^3 T}}$$

12-48 It is to be shown that $\beta = \alpha \left(\frac{\partial P}{\partial T} \right)_v$.

Analysis The definition for the volume expansivity is

$$\beta = \frac{1}{v} \left(\frac{\partial v}{\partial T} \right)_P$$

The definition for the isothermal compressibility is

$$\alpha = -\frac{1}{v} \left(\frac{\partial v}{\partial P} \right)_T$$

According to the cyclic relation,

$$\left(\frac{\partial v}{\partial T} \right)_P \left(\frac{\partial P}{\partial v} \right)_T \left(\frac{\partial T}{\partial P} \right)_v = -1$$

which on rearrangement becomes

$$\left(\frac{\partial v}{\partial T} \right)_P = - \left(\frac{\partial v}{\partial P} \right)_T \left(\frac{\partial P}{\partial T} \right)_v$$

When this is substituted into the definition of the volume expansivity, the result is

$$\begin{aligned} \beta &= -\frac{1}{v} \left(\frac{\partial v}{\partial P} \right)_T \left(\frac{\partial P}{\partial T} \right)_v \\ &= -\alpha \left(\frac{\partial P}{\partial T} \right)_v \end{aligned}$$

12-49 It is to be demonstrated that $k = \frac{c_p}{c_v} = -\frac{\nu\alpha}{(\partial\nu/\partial P)_s}$.

Analysis The relations for entropy differential are

$$ds = c_v \frac{dT}{T} + \left(\frac{\partial P}{\partial T}\right)_\nu d\nu$$

$$ds = c_p \frac{dT}{T} - \left(\frac{\partial \nu}{\partial T}\right)_P dP$$

For fixed s , these basic equations reduce to

$$c_v \frac{dT}{T} = -\left(\frac{\partial P}{\partial T}\right)_\nu d\nu$$

$$c_p \frac{dT}{T} = \left(\frac{\partial \nu}{\partial T}\right)_P dP$$

Also, when s is fixed,

$$\frac{\partial \nu}{\partial P} = \left(\frac{\partial \nu}{\partial P}\right)_s$$

Forming the specific heat ratio from these expressions gives

$$k = -\frac{\left(\frac{\partial \nu}{\partial T}\right)_P \left(\frac{\partial T}{\partial P}\right)_\nu}{\left(\frac{\partial \nu}{\partial P}\right)_s}$$

The cyclic relation is

$$\left(\frac{\partial \nu}{\partial T}\right)_P \left(\frac{\partial P}{\partial \nu}\right)_T \left(\frac{\partial T}{\partial P}\right)_\nu = -1$$

Solving this for the numerator of the specific heat ratio expression and substituting the result into this numerator produces

$$k = \frac{\left(\frac{\partial \nu}{\partial P}\right)_T}{\left(\frac{\partial \nu}{\partial P}\right)_s} = -\frac{\nu\alpha}{\left(\frac{\partial \nu}{\partial P}\right)_s}$$

12-50 The Helmholtz function of a substance has the form $a = -RT \ln \frac{v}{v_0} - cT_0 \left(1 - \frac{T}{T_0} + \frac{T}{T_0} \ln \frac{T}{T_0} \right)$. It is to be shown how to obtain P , h , s , c_v , and c_p from this expression.

Analysis Taking the Helmholtz function to be a function of temperature and specific volume yields

$$da = \left(\frac{\partial a}{\partial T} \right)_v dT + \left(\frac{\partial a}{\partial v} \right)_T dv$$

while the applicable Helmholtz equation is

$$da = -Pd v - s dT$$

Equating the coefficients of the two results produces

$$P = - \left(\frac{\partial a}{\partial v} \right)_T$$

$$s = - \left(\frac{\partial a}{\partial T} \right)_v$$

Taking the indicated partial derivatives of the Helmholtz function given in the problem statement reduces these expressions to

$$P = \frac{RT}{v}$$

$$s = R \ln \frac{v}{v_0} + c \ln \frac{T}{T_0}$$

The definition of the enthalpy ($h = u + Pv$) and Helmholtz function ($a = u - Ts$) may be combined to give

$$h = u + Pv$$

$$= a + Ts + Pv$$

$$= a - T \left(\frac{\partial a}{\partial T} \right)_v - v \left(\frac{\partial a}{\partial v} \right)_T$$

$$= -RT \ln \frac{v}{v_0} - cT_0 \left(1 - \frac{T}{T_0} + \frac{T}{T_0} \ln \frac{T}{T_0} \right) + RT \ln \frac{v}{v_0} - cT \ln \frac{T}{T_0} + RT$$

$$= cT_0 + cT + RT$$

According to $\left(\frac{\partial s}{\partial T} \right)_v = \frac{c_v}{T}$ given in the text (Eq. 12-28),

$$c_v = T \left(\frac{\partial s}{\partial T} \right)_v = T \frac{c}{T} = c$$

The preceding expression for the temperature indicates that the equation of state for the substance is the same as that of an ideal gas. Then,

$$c_p = R + c_v = R + c$$

12-51 It is to be shown that the enthalpy of an ideal gas is a function of temperature only and that for an incompressible substance it also depends on pressure.

Analysis The change in enthalpy is expressed as

$$dh = c_p dT + \left(\nu - T \left(\frac{\partial \nu}{\partial T} \right)_P \right) dP$$

For an ideal gas $\nu = RT/P$. Then,

$$\nu - T \left(\frac{\partial \nu}{\partial T} \right)_P = \nu - T \left(\frac{R}{P} \right) = \nu - \nu = 0$$

Thus,

$$dh = c_p dT$$

To complete the proof we need to show that c_p is not a function of P either. This is done with the help of the relation

$$\left(\frac{\partial c_p}{\partial P} \right)_T = -T \left(\frac{\partial^2 \nu}{\partial T^2} \right)_P$$

For an ideal gas,

$$\left(\frac{\partial \nu}{\partial T} \right)_P = \frac{R}{P} \quad \text{and} \quad \left(\frac{\partial^2 \nu}{\partial T^2} \right)_P = \left(\frac{\partial (R/P)}{\partial T} \right)_P = 0$$

Thus,

$$\left(\frac{\partial c_p}{\partial P} \right)_T = 0$$

Therefore we conclude that the enthalpy of an ideal gas is a function of temperature only.

For an incompressible substance $\nu = \text{constant}$ and thus $\partial \nu / \partial T = 0$. Then,

$$dh = c_p dT + \nu dP$$

Therefore we conclude that the enthalpy of an incompressible substance is a function of temperature and pressure.

The Joule-Thomson Coefficient

12-52C It represents the variation of temperature with pressure during a throttling process.

12-53C The line that passes through the peak points of the constant enthalpy lines on a T - P diagram is called the inversion line. The maximum inversion temperature is the highest temperature a fluid can be cooled by throttling.

12-54C No. The temperature may even increase as a result of throttling.

12-55C Yes.

12-56C No. Helium is an ideal gas and $h = h(T)$ for ideal gases. Therefore, the temperature of an ideal gas remains constant during a throttling ($h = \text{constant}$) process.

12-57E  The Joule-Thomson coefficient of nitrogen at two states is to be estimated.

Analysis (a) The enthalpy of nitrogen at 120 psia and 350 R is, from EES, $h = 84.88$ Btu/lbm. Approximating differentials by differences about the specified state, the Joule-Thomson coefficient is expressed as

$$\mu = \left(\frac{\partial T}{\partial P} \right)_h \cong \left(\frac{\Delta T}{\Delta P} \right)_{h=84.88 \text{ Btu/lbm}}$$

Considering a throttling process from 130 psia to 110 psia at $h = 84.88$ Btu/lbm, the Joule-Thomson coefficient is determined to be

$$\mu = \left(\frac{T_{110 \text{ psia}} - T_{130 \text{ psia}}}{(110 - 130) \text{ psia}} \right)_{h=84.88 \text{ Btu/lbm}} = \frac{(349.40 - 350.60) \text{ R}}{(110 - 130) \text{ psia}} = \mathbf{0.0599 \text{ R/psia}}$$

(b) The enthalpy of nitrogen at 1200 psia and 700 R is, from EES, $h = 170.14$ Btu/lbm. Approximating differentials by differences about the specified state, the Joule-Thomson coefficient is expressed as

$$\mu = \left(\frac{\partial T}{\partial P} \right)_h \cong \left(\frac{\Delta T}{\Delta P} \right)_{h=170.14 \text{ Btu/lbm}}$$

Considering a throttling process from 1210 psia to 1190 psia at $h = 170.14$ Btu/lbm, the Joule-Thomson coefficient is determined to be

$$\mu = \left(\frac{T_{1190 \text{ psia}} - T_{1210 \text{ psia}}}{(1190 - 1210) \text{ psia}} \right)_{h=170.14 \text{ Btu/lbm}} = \frac{(699.91 - 700.09) \text{ R}}{(1190 - 1210) \text{ psia}} = \mathbf{0.00929 \text{ R/psia}}$$



12-58E Problem 12-57E is reconsidered. The Joule-Thompson coefficient for nitrogen over the pressure range 100 to 1500 psia at the enthalpy values 100, 175, and 225 Btu/lbm is to be plotted.

Analysis The problem is solved using EES, and the results are tabulated and plotted below.

```

Gas$ = 'Nitrogen'
{P_ref=120 [psia]
T_ref=350 [R]
P= P_ref}
h=100 [Btu/lbm]
{h=enthalpy(Gas$, T=T_ref, P=P_ref)}
dP = 10 [psia]
T = temperature(Gas$, P=P, h=h)
P[1] = P + dP
P[2] = P - dP
T[1] = temperature(Gas$, P=P[1], h=h)
T[2] = temperature(Gas$, P=P[2], h=h)
Mu = DELTAT/DELTAP "Approximate the differential by differences about the state at h=const."
DELTAT=T[2]-T[1]
DELTAP=P[2]-P[1]

```

h = 225 Btu/lbm	
P [psia]	μ [R/psia]
100	0.004573
275	0.00417
450	0.003781
625	0.003405
800	0.003041
975	0.002688
1150	0.002347
1325	0.002015
1500	0.001694

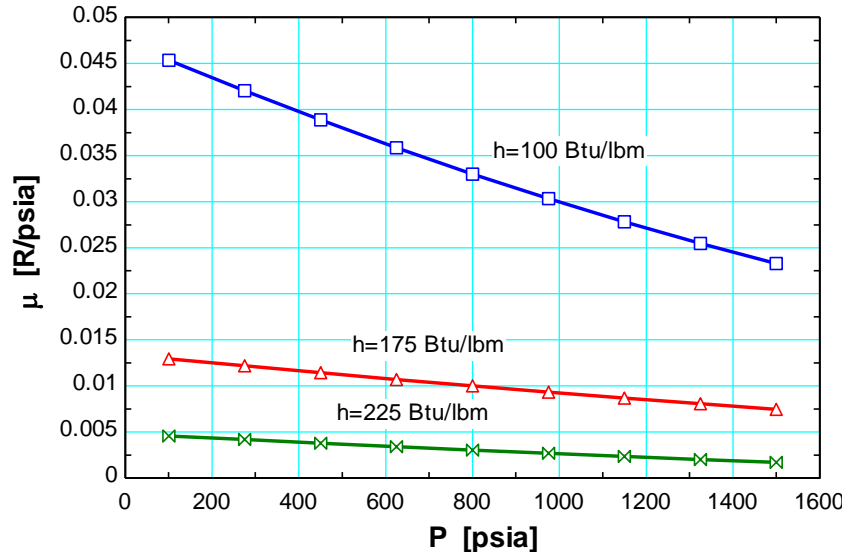

12-59 Steam is throttled slightly from 2 MPa and 500°C. It is to be determined if the temperature of the steam will increase, decrease, or remain the same during this process.

Analysis The enthalpy of steam at 2 MPa and $T = 500^\circ\text{C}$ is $h = 3468.3$ kJ/kg. Now consider a throttling process from this state to 1.8 MPa, which is the next lowest pressure listed in the tables. The temperature of the steam at the end of this throttling process will be

$$\left. \begin{array}{l} P = 1.8 \text{ MPa} \\ h = 3468.3 \text{ kJ/kg} \end{array} \right\} T_2 = 499.0^\circ\text{C}$$

Therefore, the temperature will **decrease**.

12-60 The Joule-Thomson coefficient of steam at two states is to be estimated.

Analysis (a) The enthalpy of steam at 3 MPa and 300°C is $h = 2994.3$ kJ/kg. Approximating differentials by differences about the specified state, the Joule-Thomson coefficient is expressed as

$$\mu = \left(\frac{\partial T}{\partial P} \right)_h \cong \left(\frac{\Delta T}{\Delta P} \right)_{h=2994.3 \text{ kJ/kg}}$$

Considering a throttling process from 3.5 MPa to 2.5 MPa at $h = 2994.3$ kJ/kg, the Joule-Thomson coefficient is determined to be

$$\mu = \left(\frac{T_{3.5 \text{ MPa}} - T_{2.5 \text{ MPa}}}{(3.5 - 2.5) \text{ MPa}} \right)_{h=2994.3 \text{ kJ/kg}} = \frac{(306.3 - 294)^\circ\text{C}}{(3.5 - 2.5) \text{ MPa}} = \mathbf{12.3^\circ\text{C/MPa}}$$

(b) The enthalpy of steam at 6 MPa and 500°C is $h = 3423.1$ kJ/kg. Approximating differentials by differences about the specified state, the Joule-Thomson coefficient is expressed as

$$\mu = \left(\frac{\partial T}{\partial P} \right)_h \cong \left(\frac{\Delta T}{\Delta P} \right)_{h=3423.1 \text{ kJ/kg}}$$

Considering a throttling process from 7.0 MPa to 5.0 MPa at $h = 3423.1$ kJ/kg, the Joule-Thomson coefficient is determined to be

$$\mu = \left(\frac{T_{7.0 \text{ MPa}} - T_{5.0 \text{ MPa}}}{(7.0 - 5.0) \text{ MPa}} \right)_{h=3423.1 \text{ kJ/kg}} = \frac{(504.8 - 495.1)^\circ\text{C}}{(7.0 - 5.0) \text{ MPa}} = \mathbf{4.9^\circ\text{C/MPa}}$$

12-61E The Joule-Thomson coefficient of refrigerant-134a at a given state is to be estimated.

Analysis The Joule-Thomson coefficient is defined as

$$\mu = \left(\frac{\partial T}{\partial P} \right)_h$$

We use a finite difference approximation as

$$\mu \cong \frac{T_2 - T_1}{P_2 - P_1} \quad (\text{at constant enthalpy})$$

At the given state (we call it state 1), the enthalpy of R-134a is

$$\left. \begin{array}{l} P_1 = 40 \text{ psia} \\ T_1 = 60^\circ\text{F} \end{array} \right\} h_1 = 113.80 \text{ Btu/lbm} \quad (\text{Table A - 13E})$$

The second state will be selected for a pressure of 30 psia. At this pressure and the same enthalpy, we have

$$\left. \begin{array}{l} P_2 = 30 \text{ psia} \\ h_2 = h_1 = 113.80 \text{ kJ/kg} \end{array} \right\} T_2 = 56.83^\circ\text{F} \quad (\text{Table A - 13E})$$

Substituting,

$$\mu \cong \frac{T_2 - T_1}{P_2 - P_1} = \frac{(56.83 - 60)\text{R}}{(30 - 40)\text{psia}} = \mathbf{0.317\text{R/psia}}$$

12-62 It is to be demonstrated that the Joule-Thomson coefficient is given by $\mu = \frac{T^2}{c_p} \left(\frac{\partial(\nu/T)}{\partial T} \right)_P$.

Analysis From Eq. 12-52 of the text,

$$c_p = \frac{1}{\mu} \left[T \left(\frac{\partial \nu}{\partial T} \right)_P - \nu \right]$$

Expanding the partial derivative of ν/T produces

$$\left(\frac{\partial \nu/T}{\partial T} \right)_P = \frac{1}{T} \left(\frac{\partial \nu}{\partial T} \right)_P - \frac{\nu}{T^2}$$

When this is multiplied by T^2 , the right-hand side becomes the same as the bracketed quantity above. Then,

$$\mu = \frac{T^2}{c_p} \left(\frac{\partial(\nu/T)}{\partial T} \right)_P$$

12-63 The equation of state of a gas is given to be $P(\nu - a) = RT$. It is to be determined if it is possible to cool this gas by throttling.

Analysis The equation of state of this gas can be expressed as

$$\nu = \frac{RT}{P} + a \longrightarrow \left(\frac{\partial \nu}{\partial T} \right)_P = \frac{R}{P}$$

Substituting into the Joule-Thomson coefficient relation,

$$\mu = -\frac{1}{c_p} \left(\nu - T \left(\frac{\partial \nu}{\partial T} \right)_P \right) = -\frac{1}{c_p} \left(\nu - T \frac{R}{P} \right) = -\frac{1}{c_p} (\nu - \nu + a) = -\frac{a}{c_p} < 0$$

Therefore, this gas **cannot** be cooled by throttling since μ is always a negative quantity.

12-64 Relations for the Joule-Thomson coefficient and the inversion temperature for a gas whose equation of state is $(P+a/v^2)v=RT$ are to be obtained.

Analysis The equation of state of this gas can be expressed as

$$T = \frac{v}{R} \left(P + \frac{a}{v^2} \right) \longrightarrow \left(\frac{\partial T}{\partial v} \right)_P = \frac{v}{R} \left(-\frac{2a}{v^3} \right) + \frac{1}{R} \left(P + \frac{a}{v^2} \right) = -\frac{2av}{Rv^2} + \frac{T}{v} = \frac{RTv - 2a}{Rv^2}$$

Substituting into the Joule-Thomson coefficient relation,

$$\mu = -\frac{1}{c_p} \left(v - T \left(\frac{\partial v}{\partial T} \right)_P \right) = -\frac{1}{c_p} \left(v - \frac{RTv^2}{RTv - 2a} \right) = -\frac{2av}{c_p(2a - RTv)}$$

The temperature at $\mu = 0$ is the inversion temperature,

$$\mu = -\frac{2av}{c_p(2a - RTv)} = 0 \longrightarrow v = 0$$

Thus the line of $v = 0$ is the inversion line. Since it is not physically possible to have $v = 0$, this gas does not have an inversion line.

The dh , du , and ds of Real Gases

12-65C As P_R approaches zero, the gas approaches ideal gas behavior. As a result, the deviation from ideal gas behavior diminishes.

12-66C So that a single chart can be used for all gases instead of a single particular gas.

12-67 The enthalpy of nitrogen at 175 K and 8 MPa is to be determined using data from the ideal-gas nitrogen table and the generalized enthalpy departure chart.

Analysis (a) From the ideal gas table of nitrogen (Table A-18) we read

$$h = 5083.8 \text{ kJ/kmol} = \mathbf{181.48 \text{ kJ/kg}} \quad (M_{\text{N}_2} = 28.013 \text{ kg/kmol})$$

at the specified temperature. This value involves 44.4% error.

(b) The enthalpy departure of nitrogen at the specified state is determined from the generalized chart to be

and

$$\left. \begin{aligned} T_R &= \frac{T}{T_{\text{cr}}} = \frac{175}{126.2} = 1.387 \\ P_R &= \frac{P}{P_{\text{cr}}} = \frac{8}{3.39} = 2.360 \end{aligned} \right\} \longrightarrow Z_h = \frac{(\bar{h}_{\text{ideal}} - \bar{h})_{T,P}}{R_u T_{\text{cr}}} = 1.6$$

Thus,

$$\bar{h} = \bar{h}_{\text{ideal}} - Z_h R_u T_{\text{cr}} = 5083.8 - [(1.6)(8.314)(126.2)] = 3405.0 \text{ kJ/kmol}$$

or,

$$h = \frac{\bar{h}}{M} = \frac{3405.0 \text{ kJ/kmol}}{28.013 \text{ kg/kmol}} = \mathbf{121.6 \text{ kJ/kg}} \quad (3.1\% \text{ error})$$

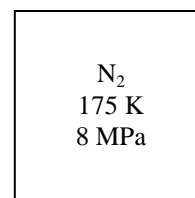

12-68E The enthalpy of nitrogen at 400 R and 2000 psia is to be determined using data from the ideal-gas nitrogen table and the generalized enthalpy departure chart.

Analysis (a) From the ideal gas table of nitrogen (Table A-18E) we read

$$h = 2777.0 \text{ Btu/lbmol} = \mathbf{99.18 \text{ Btu/lbm}} \quad (M_{\text{N}_2} = 28 \text{ lbm/lbmol})$$

at the specified temperature. This value involves 44.2% error.

(b) The enthalpy departure of nitrogen at the specified state is determined from the generalized chart to be (Fig. A-29)

$$\left. \begin{aligned} T_R &= \frac{T}{T_{\text{cr}}} = \frac{400}{227.1} = 1.761 \\ P_R &= \frac{P}{P_{\text{cr}}} = \frac{2000}{492} = 4.065 \end{aligned} \right\} \longrightarrow Z_h = \frac{(\bar{h}_{\text{ideal}} - \bar{h})_{T,P}}{R_u T_{\text{cr}}} = 1.18$$

Thus,

$$\bar{h} = \bar{h}_{\text{ideal}} - Z_h R_u T_{\text{cr}} = 2777.0 - [(1.18)(1.986)(227.1)] = 2244.8 \text{ Btu/lbmol}$$

or,

$$h = \frac{\bar{h}}{M} = \frac{2244.8 \text{ Btu/lbmol}}{28 \text{ lbm/lbmol}} = \mathbf{80.17 \text{ Btu/lbm}} \quad (54.9\% \text{ error})$$

N₂
400 R
2000 psia

12-69 The enthalpy and entropy changes of CO₂ during a process are to be determined assuming ideal gas behavior and using generalized charts.

Analysis (a) Using data from the ideal gas property table of CO₂ (Table A-20),

$$(\bar{h}_2 - \bar{h}_1)_{\text{ideal}} = \bar{h}_{2,\text{ideal}} - \bar{h}_{1,\text{ideal}} = 8,697 - 7,627 = 1,070 \text{ kJ/kmol}$$

$$(\bar{s}_2 - \bar{s}_1)_{\text{ideal}} = s_2^\circ - s_1^\circ - R_u \ln \frac{P_2}{P_1} = 211.376 - 207.337 - 8.314 \times \ln \frac{12}{7} \\ = -0.442 \text{ kJ/kmol} \cdot \text{K}$$

$$(h_2 - h_1)_{\text{ideal}} = \frac{(\bar{h}_2 - \bar{h}_1)_{\text{ideal}}}{M} = \frac{1,070 \text{ kJ/kmol}}{44 \text{ kg/kmol}} = \mathbf{24.32 \text{ kJ/kg}}$$

$$(s_2 - s_1)_{\text{ideal}} = \frac{(\bar{s}_2 - \bar{s}_1)_{\text{ideal}}}{M} = \frac{-0.442 \text{ kJ/kmol}}{44 \text{ kg/kmol}} = \mathbf{-0.0100 \text{ kJ/kg} \cdot \text{K}}$$

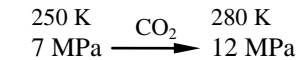

(b) The enthalpy and entropy departures of CO₂ at the specified states are determined from the generalized charts to be (Figs. A-29, A-30)

$$\left. \begin{aligned} T_{R1} &= \frac{T_1}{T_{\text{cr}}} = \frac{250}{304.2} = 0.822 \\ P_{R1} &= \frac{P_1}{P_{\text{cr}}} = \frac{7}{7.39} = 0.947 \end{aligned} \right\} \longrightarrow Z_{h1} = 5.5 \text{ and } Z_{s1} = 5.3$$

and

$$\left. \begin{aligned} T_{R2} &= \frac{T_2}{T_{\text{cr}}} = \frac{280}{304.2} = 0.920 \\ P_{R2} &= \frac{P_2}{P_{\text{cr}}} = \frac{12}{7.39} = 1.624 \end{aligned} \right\} \longrightarrow Z_{h2} = 5.0 \text{ and } Z_{s2} = 4.2$$

Thus,

$$h_2 - h_1 = RT_{\text{cr}}(Z_{h1} - Z_{h2}) + (h_2 - h_1)_{\text{ideal}} = (0.1889)(304.2)(5.5 - 5.0) + 24.32 = \mathbf{53.05 \text{ kJ/kg}}$$

$$s_2 - s_1 = R(Z_{s1} - Z_{s2}) + (s_2 - s_1)_{\text{ideal}} = (0.1889)(5.3 - 4.2) - 0.010 = \mathbf{0.198 \text{ kJ/kg} \cdot \text{K}}$$

12-70E The enthalpy and entropy changes of water vapor during a change of state are to be determined using the departure charts and the property tables.

Properties The properties of water are (Table A-1E)

$$M = 18.015 \text{ lbm/lbmol}, T_{\text{cr}} = 1164.8 \text{ R}, P_{\text{cr}} = 3200 \text{ psia}$$

Analysis (a) The pressure of water vapor during this process is

$$P_1 = P_2 = P_{\text{sat @ } 400^\circ\text{F}} = 247.26 \text{ psia}$$

Using data from the ideal gas property table of water vapor (Table A-23),

$$(\bar{h}_2 - \bar{h}_1)_{\text{ideal}} = \bar{h}_{2,\text{ideal}} - \bar{h}_{1,\text{ideal}} = 10,354.9 - 6895.6 = 3459.3 \text{ Btu/lbmol}$$

and

$$(\bar{s}_2 - \bar{s}_1)_{\text{ideal}} = s_2^\circ - s_1^\circ - R_u \ln \frac{P_2}{P_1} = 52.212 - 48.916 - 0 = 3.296 \text{ Btu/lbmol} \cdot \text{R}$$

The enthalpy and entropy departures of water vapor at the specified states are determined from the generalized charts to be (Figs. A-29, A-30 or from EES-We used EES.)

$$\left. \begin{aligned} T_{R1} &= \frac{T_1}{T_{\text{cr}}} = \frac{860}{1164.8} = 0.7380 \\ P_{R1} &= \frac{P_1}{P_{\text{cr}}} = \frac{247.26}{3200} = 0.07727 \end{aligned} \right\} \longrightarrow Z_{h1} = 0.1342 \text{ and } Z_{s1} = 0.1171$$

and

$$\left. \begin{aligned} T_{R2} &= \frac{T_2}{T_{\text{cr}}} = \frac{1260}{1164.8} = 1.081 \\ P_{R2} &= \frac{P_2}{P_{\text{cr}}} = \frac{680.56}{3200} = 0.07727 \end{aligned} \right\} \longrightarrow Z_{h2} = 0.07213 \text{ and } Z_{s2} = 0.04595$$

The enthalpy and entropy changes per mole basis are

$$\begin{aligned} \bar{h}_2 - \bar{h}_1 &= (\bar{h}_2 - \bar{h}_1)_{\text{ideal}} - R_u T_{\text{cr}} (Z_{h2} - Z_{h1}) \\ &= 3459.3 - (1.9858)(1164.8)(0.07213 - 0.1342) = 3602.9 \text{ kJ/kmol} \end{aligned}$$

$$\begin{aligned} \bar{s}_2 - \bar{s}_1 &= (\bar{s}_2 - \bar{s}_1)_{\text{ideal}} - R_u (Z_{s2} - Z_{s1}) \\ &= 3.296 - (1.9858)(0.04595 - 0.1171) = 3.4373 \text{ Btu/lbmol} \cdot \text{R} \end{aligned}$$

The enthalpy and entropy changes per mass basis are

$$\begin{aligned} h_2 - h_1 &= \frac{\bar{h}_2 - \bar{h}_1}{M} = \frac{3602.9 \text{ Btu/lbmol}}{18.015 \text{ lbm/lbmol}} = \mathbf{200.0 \text{ Btu/lbm}} \\ s_2 - s_1 &= \frac{\bar{s}_2 - \bar{s}_1}{M} = \frac{3.4373 \text{ Btu/lbmol} \cdot \text{K}}{18.015 \text{ lbm/lbmol}} = \mathbf{0.1908 \text{ Btu/lbm} \cdot \text{R}} \end{aligned}$$

(b) The inlet and exit state properties of water are

$$\left. \begin{aligned} T_1 &= 400^\circ\text{F} \\ x_1 &= 1 \end{aligned} \right\} \begin{aligned} h_1 &= 1201.4 \text{ Btu/lbm} \\ s_1 &= 1.5279 \text{ Btu/lbm} \cdot \text{R} \end{aligned} \quad (\text{Table A-4E})$$

$$\left. \begin{aligned} P_2 &= 247.26 \text{ psia} \\ T_2 &= 800^\circ\text{F} \end{aligned} \right\} \begin{aligned} h_2 &= 1423.6 \text{ Btu/lbm} \\ s_2 &= 1.7418 \text{ Btu/lbm} \cdot \text{R} \end{aligned} \quad (\text{from EES})$$

The enthalpy and entropy changes are

$$\begin{aligned} h_2 - h_1 &= 1423.6 - 1201.4 = \mathbf{222.2 \text{ Btu/lbm}} \\ s_2 - s_1 &= 1.7418 - 1.5279 = \mathbf{0.2139 \text{ Btu/lbm} \cdot \text{R}} \end{aligned}$$

12-71 The enthalpy and entropy changes of water vapor during a change of state are to be determined using the departure charts and the property tables.

Properties The properties of water are (Table A-1)

$$M = 18.015 \text{ kg/kmol}, T_{\text{cr}} = 647.1 \text{ K}, P_{\text{cr}} = 22.06 \text{ MPa}$$

Analysis Using data from the ideal gas property table of water vapor (Table A-23),

$$(\bar{h}_2 - \bar{h}_1)_{\text{ideal}} = \bar{h}_{2,\text{ideal}} - \bar{h}_{1,\text{ideal}} = 23,082 - 30,754 = -7672 \text{ kJ/kmol}$$

and

$$(\bar{s}_2 - \bar{s}_1)_{\text{ideal}} = s_2^\circ - s_1^\circ - R_u \ln \frac{P_2}{P_1} = 217.141 - 227.109 - 8.314 \times \ln \frac{500}{1000} = -4.2052 \text{ kJ/kmol} \cdot \text{K}$$

The enthalpy and entropy departures of water vapor at the specified states are determined from the generalized charts to be (Figs. A-29, A-30 or from EES)

$$\left. \begin{aligned} T_{R1} &= \frac{T_1}{T_{\text{cr}}} = \frac{873}{647.1} = 1.349 \\ P_{R1} &= \frac{P_1}{P_{\text{cr}}} = \frac{1}{22.06} = 0.0453 \end{aligned} \right\} \longrightarrow Z_{h1} = 0.0288 \text{ and } Z_{s1} = 0.0157$$

and

$$\left. \begin{aligned} T_{R2} &= \frac{T_2}{T_{\text{cr}}} = \frac{673}{647.1} = 1.040 \\ P_{R2} &= \frac{P_2}{P_{\text{cr}}} = \frac{0.5}{22.06} = 0.0227 \end{aligned} \right\} \longrightarrow Z_{h2} = 0.0223 \text{ and } Z_{s2} = 0.0146$$

The enthalpy and entropy changes per mole basis are

$$\begin{aligned} \bar{h}_2 - \bar{h}_1 &= (\bar{h}_2 - \bar{h}_1)_{\text{ideal}} - R_u T_{\text{cr}} (Z_{h2} - Z_{h1}) \\ &= -7672 - (8.314)(647.1)(0.0223 - 0.0288) = -7637 \text{ kJ/kmol} \end{aligned}$$

$$\begin{aligned} \bar{s}_2 - \bar{s}_1 &= (\bar{s}_2 - \bar{s}_1)_{\text{ideal}} - R_u (Z_{s2} - Z_{s1}) \\ &= -4.2052 - (8.314)(0.0146 - 0.0157) = -4.1961 \text{ kJ/kmol} \cdot \text{K} \end{aligned}$$

The enthalpy and entropy changes per mass basis are

$$\begin{aligned} h_2 - h_1 &= \frac{\bar{h}_2 - \bar{h}_1}{M} = \frac{-7637 \text{ kJ/kmol}}{18.015 \text{ kg/kmol}} = \mathbf{-423.9 \text{ kJ/kg}} \\ s_2 - s_1 &= \frac{\bar{s}_2 - \bar{s}_1}{M} = \frac{-4.1961 \text{ kJ/kmol} \cdot \text{K}}{18.015 \text{ kg/kmol}} = \mathbf{-0.2329 \text{ kJ/kg} \cdot \text{K}} \end{aligned}$$

The inlet and exit state properties of water vapor from Table A-6 are

$$\left. \begin{aligned} P_1 &= 1000 \text{ kPa} \\ T_1 &= 600^\circ\text{C} \end{aligned} \right\} \begin{aligned} h_1 &= 3698.6 \text{ kJ/kg} \\ s_1 &= 8.0311 \text{ kJ/kg} \cdot \text{K} \end{aligned}$$

$$\left. \begin{aligned} P_2 &= 500 \text{ kPa} \\ T_2 &= 400^\circ\text{C} \end{aligned} \right\} \begin{aligned} h_2 &= 3272.4 \text{ kJ/kg} \\ s_2 &= 7.7956 \text{ kJ/kg} \cdot \text{K} \end{aligned}$$

The enthalpy and entropy changes are

$$\begin{aligned} h_2 - h_1 &= 3272.4 - 3698.6 = \mathbf{-426.2 \text{ kJ/kg}} \\ s_2 - s_1 &= 7.7956 - 8.0311 = \mathbf{-0.2355 \text{ kJ/kg} \cdot \text{K}} \end{aligned}$$

12-72 Methane is compressed adiabatically by a steady-flow compressor. The required power input to the compressor is to be determined using the generalized charts.

Assumptions 1 Steady operating conditions exist. 2 Kinetic and potential energy changes are negligible.

Analysis The steady-flow energy balance equation for this compressor can be expressed as

$$\begin{aligned}\dot{E}_{\text{in}} - \dot{E}_{\text{out}} &= \Delta \dot{E}_{\text{system}}^{\phi^0(\text{steady})} = 0 \\ \dot{E}_{\text{in}} &= \dot{E}_{\text{out}} \\ \dot{W}_{\text{C,in}} + \dot{m}h_1 &= \dot{m}h_2 \\ \dot{W}_{\text{C,in}} &= \dot{m}(h_2 - h_1)\end{aligned}$$

The enthalpy departures of CH_4 at the specified states are determined from the generalized charts to be (Fig. A-29)

$$\left. \begin{aligned}T_{R1} &= \frac{T_1}{T_{\text{cr}}} = \frac{263}{191.1} = 1.376 \\ P_{R1} &= \frac{P_1}{P_{\text{cr}}} = \frac{0.8}{4.64} = 0.172\end{aligned} \right\} \longrightarrow Z_{h1} = 0.075$$

and

$$\left. \begin{aligned}T_{R2} &= \frac{T_2}{T_{\text{cr}}} = \frac{448}{191.1} = 2.34 \\ P_{R2} &= \frac{P_2}{P_{\text{cr}}} = \frac{6}{4.64} = 1.29\end{aligned} \right\} \longrightarrow Z_{h2} = 0.25$$

Thus,

$$\begin{aligned}h_2 - h_1 &= RT_{\text{cr}}(Z_{h1} - Z_{h2}) + (h_2 - h_1)_{\text{ideal}} \\ &= (0.5182)(191.1)(0.075 - 0.25) + 2.2537(175 - (-10)) \\ &= 399.6 \text{ kJ/kg}\end{aligned}$$

Substituting,

$$\dot{W}_{\text{C,in}} = (0.33 \text{ kg/s})(399.6 \text{ kJ/kg}) = \mathbf{132 \text{ kW}}$$

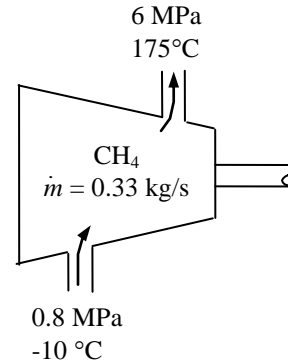

12-73 Carbon dioxide passes through an adiabatic nozzle. The exit velocity is to be determined using the generalized enthalpy departure chart.

Assumptions 1 Steady operating conditions exist. 2 Kinetic and potential energy changes are negligible. 3 The nozzle is adiabatic and thus heat transfer is negligible

Properties The gas constant of CO_2 is $0.1889 \text{ kJ/kg}\cdot\text{K}$ (Table A-1).

Analysis The steady-flow energy balance equation for this nozzle can be expressed as

$$\begin{aligned}\dot{E}_{\text{in}} - \dot{E}_{\text{out}} &= \Delta \dot{E}_{\text{system}}^{\phi^0(\text{steady})} = 0 \\ \dot{E}_{\text{in}} &= \dot{E}_{\text{out}} \\ h_1 + (V_1^2/2)^{\phi^0} &= h_2 + (V_2^2/2) \\ V_2 &= \sqrt{2(h_1 - h_2)}\end{aligned}$$

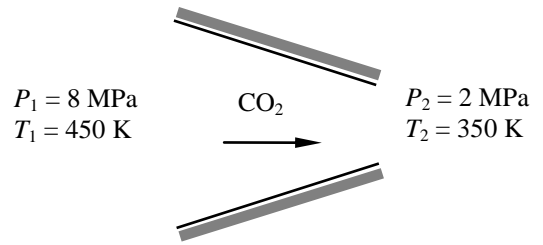

The enthalpy departures of CO_2 at the specified states are determined from the generalized enthalpy departure chart to be

$$\left. \begin{aligned} T_{R1} &= \frac{T_1}{T_{\text{cr}}} = \frac{450}{304.2} = 1.48 \\ P_{R1} &= \frac{P_1}{P_{\text{cr}}} = \frac{8}{7.39} = 1.08 \end{aligned} \right\} \longrightarrow Z_{h1} = 0.55$$

and

$$\left. \begin{aligned} T_{R2} &= \frac{T_2}{T_{\text{cr}}} = \frac{350}{304.2} = 1.15 \\ P_{R2} &= \frac{P_2}{P_{\text{cr}}} = \frac{2}{7.39} = 0.27 \end{aligned} \right\} \longrightarrow Z_{h2} = 0.20$$

Thus,

$$\begin{aligned} h_2 - h_1 &= RT_{\text{cr}}(Z_{h1} - Z_{h2}) + (h_2 - h_1)_{\text{ideal}} \\ &= (0.1889)(304.2)(0.55 - 0.2) + (11,351 - 15,483)/44 = -73.8 \text{ kJ/kg} \end{aligned}$$

Substituting,

$$V_2 = \sqrt{2(73.8 \text{ kJ/kg}) \left(\frac{1000 \text{ m}^2/\text{s}^2}{1 \text{ kJ/kg}} \right)} = \mathbf{384 \text{ m/s}}$$



12-74 Problem 12-73 is reconsidered. the exit velocity to the nozzle assuming ideal gas behavior, the generalized chart data, and EES data for carbon dioxide are to be compared.

Analysis The problem is solved using EES, and the results are given below.

```

Procedure INFO(Name$: Fluid$, T_critical, p_critical)
If Name$='CarbonDioxide' then
    T_critical=304.2 ; p_critical=7390 ; Fluid$='CO2'
endif

END

T[1]=450 [K]
P[1]=8000 [kPa]
P[2]=2000 [kPa]
T[2]=350 [K]
Name$='CarbonDioxide'

Call INFO(Name$: Fluid$, T_critical, P_critical)
R_u=8.314
M=molarmass(Fluid$)
R=R_u/M

***** IDEAL GAS SOLUTION *****
"State 1 and 2"
h_ideal[1]=enthalpy(Fluid$, T=T[1]) "Enthalpy of ideal gas"
h_ideal[2]=enthalpy(Fluid$, T=T[2]) "Enthalpy of ideal gas"
"Exit velocity:"
V_2_ideal=SQRT(2*(h_ideal[1]-h_ideal[2])*convert(kJ/kg,m^2/s^2)) "[m/s]"

***** COMPRESSABILITY CHART SOLUTION *****
"State 1"
Tr[1]=T[1]/T_critical
Pr[1]=P[1]/P_critical
DELTAh[1]=ENTHDEP(Tr[1], Pr[1])*R*T_critical "Enthalpy departure"
h[1]=h_ideal[1]-DELTAh[1] "Enthalpy of real gas using charts"

"State 2"
Tr[2]=T[2]/T_critical
Pr[2]=P[2]/P_critical
DELTAh[2]=ENTHDEP(Tr[2], Pr[2])*R*T_critical "Enthalpy departure"
h[2]=h_ideal[2]-DELTAh[2] "Enthalpy of real gas using charts"

"Exit velocity:"
V_2_EnthDep=SQRT(2*(h[1]-h[2])*convert(kJ/kg,m^2/s^2)) "[m/s]"

***** SOLUTION USING EES BUILT-IN PROPERTY DATA *****
"At state 1 and 2"
h_ees[1]=enthalpy(Name$,T=T[1],P=P[1])
h_ees[2]=enthalpy(Name$,T=T[2],P=P[2])

"Exit velocity:"
V_2_ees=SQRT(2*(h_ees[1]-h_ees[2])*convert(kJ/kg,m^2/s^2)) "[m/s]"

```

SOLUTION

DELTAh[1]=34.19 [kJ/kg]

DELTAh[2]=13.51 [kJ/kg]

Fluid\$='CO2'

h[1]=-8837 [kJ/kg]

h[2]=-8910 [kJ/kg]

h_ees[1]=106.4 [kJ/kg]

h_ees[2]=31.38 [kJ/kg]

h_ideal[1]=-8803 [kJ/kg]

h_ideal[2]=-8897 [kJ/kg]

M=44.01 [kg/kmol]

Name\$='CarbonDioxide'

P[1]=8000 [kPa]

P[2]=2000 [kPa]

Pr[1]=1.083

Pr[2]=0.2706

P_critical=7390 [kPa]

R=0.1889 [kJ/kg-K]

R_u=8.314 [kJ/kmol-K]

T[1]=450 [K]

T[2]=350 [K]

Tr[1]=1.479

Tr[2]=1.151

T_critical=304.2 [K]

V_2_ees=387.4 [m/s]

V_2_EnthDep=382.3 [m/s]

V_2_ideal=433 [m/s]

12-75E Oxygen is to be adiabatically and reversibly expanded in a nozzle. The exit velocity is to be determined using the departure charts and treating the oxygen as an ideal gas with temperature variable specific heats.

Properties The properties of oxygen are (Table A-1)

$$M = 31.999 \text{ lbm/lbmol}, R = 0.06206 \text{ Btu/lbm} \cdot \text{R}, T_{\text{cr}} = 278.6 \text{ R}, P_{\text{cr}} = 736 \text{ psia}$$

Analysis The temperature at the exit state may be determined by the fact that the process is isentropic and the molar entropy change between the inlet and exit is zero. From the entropy change equation for an ideal gas with variable specific heats:

$$\begin{aligned} (\bar{s}_2 - \bar{s}_1)_{\text{ideal}} &= 0 \\ s_2^\circ - s_1^\circ &= R_u \ln \frac{P_2}{P_1} = (1.9858) \ln \frac{70}{200} = -2.085 \text{ Btu/lbmol} \cdot \text{R} \end{aligned}$$

Then from Table A-19E,

$$\begin{aligned} T_1 &= 1060 \text{ R} \longrightarrow \bar{h}_{1,\text{ideal}} = 7543.6 \text{ Btu/lbmol}, s_1^\circ = 53.921 \text{ Btu/lbmol} \cdot \text{R} \\ s_2^\circ &= s_1^\circ - 2.085 = 53.921 - 2.085 = 51.836 \text{ Btu/lbmol} \cdot \text{R} \\ s_2^\circ &= 51.836 \text{ Btu/lbmol} \cdot \text{R} \longrightarrow T_2 = 802 \text{ R}, \bar{h}_{2,\text{ideal}} = 5614.1 \text{ Btu/lbmol} \end{aligned}$$

The enthalpy change per mole basis is

$$(\bar{h}_2 - \bar{h}_1)_{\text{ideal}} = \bar{h}_{2,\text{ideal}} - \bar{h}_{1,\text{ideal}} = 5614.1 - 7543.6 = -1929.5 \text{ Btu/lbmol}$$

The enthalpy change per mass basis is

$$(h_2 - h_1)_{\text{ideal}} = \frac{(\bar{h}_2 - \bar{h}_1)_{\text{ideal}}}{M} = \frac{-1929.5 \text{ Btu/lbmol}}{31.999 \text{ lbm/lbmol}} = -60.30 \text{ Btu/lbm}$$

An energy balance on the nozzle gives

$$\begin{aligned} \dot{E}_{\text{in}} &= \dot{E}_{\text{out}} \\ \dot{m}(h_1 + V_1^2 / 2) &= \dot{m}(h_2 + V_2^2 / 2) \\ h_1 + V_1^2 / 2 &= h_2 + V_2^2 / 2 \end{aligned}$$

Solving for the exit velocity,

$$V_2 = \left[V_1^2 + 2(h_1 - h_2) \right]^{0.5} = \left[(0 \text{ ft/s})^2 + 2(60.30 \text{ Btu/lbm}) \left(\frac{25,037 \text{ ft}^2/\text{s}^2}{1 \text{ Btu/lbm}} \right) \right]^{0.5} = \mathbf{1738 \text{ ft/s}}$$

The enthalpy departures of oxygen at the specified states are determined from the generalized charts to be (Fig. A-29 or from EES)

$$\left. \begin{aligned} T_{R1} &= \frac{T_1}{T_{\text{cr}}} = \frac{1060}{278.6} = 3.805 \\ P_{R1} &= \frac{P_1}{P_{\text{cr}}} = \frac{200}{736} = 0.272 \end{aligned} \right\} Z_{h1} = 0.000759 \quad \left. \begin{aligned} T_{R2} &= \frac{T_2}{T_{\text{cr}}} = \frac{802}{278.6} = 2.879 \\ P_{R2} &= \frac{P_2}{P_{\text{cr}}} = \frac{70}{736} = 0.0951 \end{aligned} \right\} Z_{h2} = 0.00894$$

The enthalpy change is

$$\begin{aligned} h_2 - h_1 &= (h_2 - h_1)_{\text{ideal}} - RT_{\text{cr}}(Z_{h2} - Z_{h1}) \\ &= -60.30 \text{ Btu/lbm} - (0.06206 \text{ Btu/lbm} \cdot \text{R})(278.6 \text{ R})(0.00894 - 0.000759) \\ &= -60.44 \text{ Btu/lbm} \end{aligned}$$

The exit velocity is

$$V_2 = \left[V_1^2 + 2(h_1 - h_2) \right]^{0.5} = \left[(0 \text{ ft/s})^2 + 2(60.44 \text{ Btu/lbm}) \left(\frac{25,037 \text{ ft}^2/\text{s}^2}{1 \text{ Btu/lbm}} \right) \right]^{0.5} = \mathbf{1740 \text{ ft/s}}$$

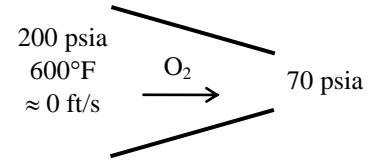

12-76  Propane is compressed isothermally by a piston-cylinder device. The work done and the heat transfer are to be determined using the generalized charts.

Assumptions **1** The compression process is quasi-equilibrium. **2** Kinetic and potential energy changes are negligible.

Analysis (a) The enthalpy departure and the compressibility factors of propane at the initial and the final states are determined from the generalized charts to be (Figs. A-29, A-15)

$$\left. \begin{aligned} T_{R1} &= \frac{T_1}{T_{cr}} = \frac{373}{370} = 1.008 \\ P_{R1} &= \frac{P_1}{P_{cr}} = \frac{1}{4.26} = 0.235 \end{aligned} \right\} \longrightarrow Z_{h1} = 0.28 \text{ and } Z_1 = 0.92$$

and

$$\left. \begin{aligned} T_{R2} &= \frac{T_2}{T_{cr}} = \frac{373}{370} = 1.008 \\ P_{R2} &= \frac{P_2}{P_{cr}} = \frac{4}{4.26} = 0.939 \end{aligned} \right\} \longrightarrow Z_{h2} = 1.8 \text{ and } Z_2 = 0.50$$

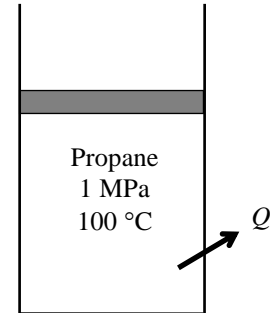

Treating propane as a real gas with $Z_{\text{avg}} = (Z_1 + Z_2)/2 = (0.92 + 0.50)/2 = 0.71$,

$$Pv = ZRT \cong Z_{\text{avg}}RT = C = \text{constant}$$

Then the boundary work becomes

$$\begin{aligned} w_{b,\text{in}} &= -\int_1^2 Pd\nu = -\int_1^2 \frac{C}{\nu} d\nu = -C \ln \frac{\nu_2}{\nu_1} = Z_{\text{avg}}RT \ln \frac{Z_2 RT / P_2}{Z_1 RT / P_1} = -Z_{\text{ave}}RT \ln \frac{Z_2 P_1}{Z_1 P_2} \\ &= -(0.71)(0.1885 \text{ kJ/kg} \cdot \text{K})(373 \text{ K}) \ln \frac{(0.50)(1)}{(0.92)(4)} \\ &= \mathbf{99.6 \text{ kJ/kg}} \end{aligned}$$

Also,

$$\begin{aligned} h_2 - h_1 &= RT_{cr}(Z_{h1} - Z_{h2}) + (h_2 - h_1)_{\text{ideal}} = (0.1885)(370)(0.28 - 1.8) + 0 = -106 \text{ kJ/kg} \\ u_2 - u_1 &= (h_2 - h_1) - R(Z_2 T_2 - Z_1 T_1) = -106 - (0.1885)[(0.5)(373) - (0.92)(373)] = -76.5 \text{ kJ/kg} \end{aligned}$$

Then the heat transfer for this process is determined from the closed system energy balance to be

$$\begin{aligned} E_{\text{in}} - E_{\text{out}} &= \Delta E_{\text{system}} \\ q_{\text{in}} + w_{b,\text{in}} &= \Delta u = u_2 - u_1 \\ q_{\text{in}} &= (u_2 - u_1) - w_{b,\text{in}} = -76.5 - 99.6 = -176.1 \text{ kJ/kg} \quad \rightarrow \quad q_{\text{out}} = 176.1 \text{ kJ/kg} \end{aligned}$$



12-77 Problem 12-76 is reconsidered. This problem is to be extended to compare the solutions based on the ideal gas assumption, generalized chart data and real fluid (EES) data. Also, the solution is to be extended to carbon dioxide, nitrogen and methane.

Analysis The problem is solved using EES, and the solution is given below.

```

Procedure INFO(Name$, T[1] : Fluid$, T_critical, p_critical)
If Name$='Propane' then
    T_critical=370 ; p_critical=4620 ; Fluid$='C3H8'; goto 10
endif
If Name$='Methane' then
    T_critical=191.1 ; p_critical=4640 ; Fluid$='CH4'; goto 10
endif
If Name$='Nitrogen' then
    T_critical=126.2 ; p_critical=3390 ; Fluid$='N2'; goto 10
endif
If Name$='Oxygen' then
    T_critical=154.8 ; p_critical=5080 ; Fluid$='O2'; goto 10
endif
If Name$='CarbonDioxide' then
    T_critical=304.2 ; p_critical=7390 ; Fluid$='CO2' ; goto 10
endif
If Name$='n-Butane' then
    T_critical=425.2 ; p_critical=3800 ; Fluid$='C4H10' ; goto 10
endif

10:
    If T[1]<=T_critical then
    CALL ERROR('The supplied temperature must be greater than the critical temperature for the fluid. A value of
    XXXF1 K was supplied',T[1])
    endif

end

{"Data from the Diagram Window"
T[1]=100+273.15
p[1]=1000
p[2]=4000
Name$='Propane'
Fluid$='C3H8' }

Call INFO(Name$, T[1] : Fluid$, T_critical, p_critical)
R_u=8.314
M=molarmass(Fluid$)
R=R_u/M

***** IDEAL GAS SOLUTION *****
"State 1"
h_ideal[1]=enthalpy(Fluid$, T=T[1]) "Enthalpy of ideal gas"
s_ideal[1]=entropy(Fluid$, T=T[1], p=p[1]) "Entropy of ideal gas"
u_ideal[1]=h_ideal[1]-R*T[1] "Internal energy of ideal gas"
"State 2"
h_ideal[2]=enthalpy(Fluid$, T=T[2]) "Enthalpy of ideal gas"
s_ideal[2]=entropy(Fluid$, T=T[2], p=p[2]) "Entropy of ideal gas"
u_ideal[2]=h_ideal[2]-R*T[2] "Internal energy of ideal gas"

"Work is the integral of p dv, which can be done analytically."
w_ideal=R*T[1]*Ln(p[1]/p[2])

```

"First Law - note that $u_{ideal[2]}$ is equal to $u_{ideal[1]}$ "

$$q_{ideal} - w_{ideal} = u_{ideal[2]} - u_{ideal[1]}$$

"Entropy change"

$$\Delta s_{ideal} = s_{ideal[2]} - s_{ideal[1]}$$

***** COMPRESSIBILITY CHART SOLUTION *****

"State 1"

$$Tr[1] = T[1] / T_{critical}$$

$$pr[1] = p[1] / p_{critical}$$

$$Z[1] = COMPRESS(Tr[1], Pr[1])$$

$$\Delta h[1] = ENTHDEP(Tr[1], Pr[1]) * R * T_{critical} \quad \text{"Enthalpy departure"}$$

$$h[1] = h_{ideal[1]} - \Delta h[1] \quad \text{"Enthalpy of real gas using charts"}$$

$$u[1] = h[1] - Z[1] * R * T[1]$$

"Internal energy of gas using charts"

$$\Delta s[1] = ENTRDEP(Tr[1], Pr[1]) * R \quad \text{"Entropy departure"}$$

$$s[1] = s_{ideal[1]} - \Delta s[1] \quad \text{"Entropy of real gas using charts"}$$

"State 2"

$$T[2] = T[1]$$

$$Tr[2] = Tr[1]$$

$$pr[2] = p[2] / p_{critical}$$

$$Z[2] = COMPRESS(Tr[2], Pr[2])$$

$$\Delta h[2] = ENTHDEP(Tr[2], Pr[2]) * R * T_{critical} \quad \text{"Enthalpy departure"}$$

$$\Delta s[2] = ENTRDEP(Tr[2], Pr[2]) * R \quad \text{"Entropy departure"}$$

$$h[2] = h_{ideal[2]} - \Delta h[2] \quad \text{"Enthalpy of real gas using charts"}$$

$$s[2] = s_{ideal[2]} - \Delta s[2] \quad \text{"Entropy of real gas using charts"}$$

$$u[2] = h[2] - Z[2] * R * T[2]$$

"Internal energy of gas using charts"

"Work using charts - note use of EES integral function to evaluate the integral of $p \, dv$."

$$w_{chart} = \text{Integral}(p, v, v[1], v[2])$$

"We need an equation to relate p and v in the above INTEGRAL function. "

$$p * v = COMPRESS(Tr[2], p / p_{critical}) * R * T[1] \quad \text{"To specify relationship between } p \text{ and } v"$$

"Find the limits of integration"

$$p[1] * v[1] = Z[1] * R * T[1] \quad \text{"to get } v[1], \text{ the lower bound"}$$

$$p[2] * v[2] = Z[2] * R * T[2] \quad \text{"to get } v[2], \text{ the upper bound"}$$

"First Law - note that $u[2]$ is not equal to $u[1]$ "

$$q_{chart} - w_{chart} = u[2] - u[1]$$

"Entropy Change"

$$\Delta s_{chart} = s[2] - s[1]$$

***** SOLUTION USING EES BUILT-IN PROPERTY DATA *****

"At state 1"

$$u_{ees}[1] = \text{intEnergy}(\text{Name}\$, T = T[1], p = p[1])$$

$$s_{ees}[1] = \text{entropy}(\text{Name}\$, T = T[1], p = p[1])$$

"At state 2"

$$u_{ees}[2] = \text{intEnergy}(\text{Name}\$, T = T[2], p = p[2])$$

$$s_{ees}[2] = \text{entropy}(\text{Name}\$, T = T[2], p = p[2])$$

"Work using EES built-in properties- note use of EES Integral function to evaluate the integral of $p \, dv$."

$$w_{ees} = \text{integral}(p_{ees}, v_{ees}, v_{ees}[1], v_{ees}[2])$$

"The following equation relates p and v in the above INTEGRAL"

$$p_{ees} = \text{pressure}(\text{Name}\$, T = T[1], v = v_{ees}) \quad \text{"To specify relationship between } p \text{ and } v"$$

"Find the limits of integration"

$$v_{ees}[1] = \text{volume}(\text{Name}\$, T = T[1], p = p[1]) \quad \text{"to get lower bound"}$$

$$v_{ees}[2] = \text{volume}(\text{Name}\$, T = T[2], p = p[2]) \quad \text{"to get upper bound"}$$

"First law - note that $u_{ees}[2]$ is not equal to $u_{ees}[1]$ "

$$q_{ees} - w_{ees} = u_{ees}[2] - u_{ees}[1]$$

"Entropy change"

$$\text{DELTA}s_{\text{ees}} = s_{\text{ees}[2]} - s_{\text{ees}[1]}$$

"Note: In all three solutions to this problem we could have calculated the heat transfer by $q/T = \text{DELTA}_s$ since T is constant. Then the first law could have been used to find the work. The use of integral of $p dv$ to find the work is a more fundamental approach and can be used if T is not constant."

SOLUTION

DELTAh[1]=16.48 [kJ/kg]	s[2]=5.657 [kJ/kg-K]
DELTAh[2]=91.96 [kJ/kg]	s_ees[1]=2.797 [kJ/kg-K]
DELTA _s [1]=0.03029 [kJ/kg-K]	s_ees[2]=2.326 [kJ/kg-K]
DELTA _s [2]=0.1851 [kJ/kg-K]	s_ideal[1]=6.103 [kJ/kg-K]
DELTA _s _chart=-0.4162 [kJ/kg-K]	s_ideal[2]=5.842 [kJ/kg-K]
DELTA _s _ees=-0.4711 [kJ/kg-K]	T[1]=373.2 [K]
DELTA _s _ideal=-0.2614 [kJ/kg-K]	T[2]=373.2 [K]
Fluid\$='C3H8'	Tr[1]=1.009
h[1]=-2232 [kJ/kg]	Tr[2]=1.009
h[2]=-2308 [kJ/kg]	T_critical=370 [K]
h_ideal[1]=-2216 [kJ/kg]	u[1]=-2298 [kJ/kg]
h_ideal[2]=-2216 [kJ/kg]	u[2]=-2351 [kJ/kg]
M=44.1	u_ees[1]=688.4 [kJ/kg]
Name\$='Propane'	u_ees[2]=617.1 [kJ/kg]
p=4000	u_ideal[1]=-2286 [kJ/kg]
p[1]=1000 [kPa]	u_ideal[2]=-2286 [kJ/kg]
p[2]=4000 [kPa]	v=0.01074
pr[1]=0.2165	v[1]=0.06506 [m ³ /kg]
pr[2]=0.8658	v[2]=0.01074 [m ³ /kg]
p_critical=4620 [kPa]	v_ees=0.009426
p_ees=4000	v_ees[1]=0.0646 [m ³ /kg]
q_chart=-155.3 [kJ/kg]	v_ees[2]=0.009426 [m ³ /kg]
q_ees=-175.8 [kJ/kg]	w_chart=-101.9 [kJ/kg]
q_ideal=-97.54 [kJ/kg]	w_ees=-104.5 [kJ/kg]
R=0.1885 [kJ/kg-K]	w_ideal=-97.54 [kJ/kg]
R_u=8.314 [kJ/mole-K]	Z[1]=0.9246
s[1]=6.073 [kJ/kg-K]	Z[2]=0.6104

12-78 Propane is compressed isothermally by a piston-cylinder device. The exergy destruction associated with this process is to be determined.

Assumptions 1 The compression process is quasi-equilibrium. 2 Kinetic and potential energy changes are negligible.

Properties The gas constant of propane is $R = 0.1885 \text{ kJ/kg}\cdot\text{K}$ (Table A-1).

Analysis The exergy destruction is determined from its definition $x_{\text{destroyed}} = T_0 s_{\text{gen}}$ where the entropy generation is determined from an entropy balance on the contents of the cylinder. It gives

$$S_{\text{in}} - S_{\text{out}} + S_{\text{gen}} = \Delta S_{\text{system}}$$

$$-\frac{Q_{\text{out}}}{T_{b,\text{surr}}} + S_{\text{gen}} = m(s_2 - s_1) \rightarrow s_{\text{gen}} = (s_2 - s_1) + \frac{q_{\text{out}}}{T_{\text{surr}}}$$

where

$$\Delta s_{\text{sys}} = s_2 - s_1 = R(Z_{s1} - Z_{s2}) + (s_2 - s_1)_{\text{ideal}}$$

$$(s_2 - s_1)_{\text{ideal}} = c_p \ln \frac{T_2}{T_1} - R \ln \frac{P_2}{P_1} = 0 - 0.1885 \ln \frac{4}{1} = -0.261 \text{ kJ/kg}\cdot\text{K}$$

$$\left. \begin{aligned} T_{R1} &= \frac{T_1}{T_{\text{cr}}} = \frac{373}{370} = 1.008 \\ P_{R1} &= \frac{P_1}{P_{\text{cr}}} = \frac{1}{4.26} = 0.235 \end{aligned} \right\} \longrightarrow Z_{s1} = 0.21$$

and

$$\left. \begin{aligned} T_{R2} &= \frac{T_2}{T_{\text{cr}}} = \frac{373}{370} = 1.008 \\ P_{R2} &= \frac{P_2}{P_{\text{cr}}} = \frac{4}{4.26} = 0.939 \end{aligned} \right\} \longrightarrow Z_{s2} = 1.5$$

Thus,

$$\Delta s_{\text{sys}} = s_2 - s_1 = R(Z_{s1} - Z_{s2}) + (s_2 - s_1)_{\text{ideal}} = (0.1885)(0.21 - 1.5) - 0.261 = -0.504 \text{ kJ/kg}\cdot\text{K}$$

and

$$x_{\text{destroyed}} = T_0 s_{\text{gen}} = T_0 \left((s_2 - s_1) + \frac{q_{\text{out}}}{T_{\text{surr}}} \right)$$

$$= (298 \text{ K}) \left(-0.504 + \frac{176.1 \text{ kJ/kg}}{298 \text{ K}} \right) \text{ kJ/kg}\cdot\text{K}$$

$$= \mathbf{25.9 \text{ kJ/kg}}$$

12-79 A paddle-wheel placed in a well-insulated rigid tank containing oxygen is turned on. The final pressure in the tank and the paddle-wheel work done during this process are to be determined.

Assumptions 1 The tank is well-insulated and thus heat transfer is negligible. 2 Kinetic and potential energy changes are negligible.

Properties The gas constant of O_2 is $R = 0.2598 \text{ kJ/kg}\cdot\text{K}$ (Table A-1).

Analysis (a) For this problem, we use critical properties, compressibility factor, and enthalpy departure factors in EES. The compressibility factor of oxygen at the initial state is determined from EES to be

$$\left. \begin{aligned} T_{R1} &= \frac{T_1}{T_{cr}} = \frac{175}{154.6} = 1.13 \\ P_{R1} &= \frac{P_1}{P_{cr}} = \frac{6}{5.043} = 1.19 \end{aligned} \right\} \longrightarrow Z_1 = 0.682 \text{ and } Z_{h1} = 1.33$$

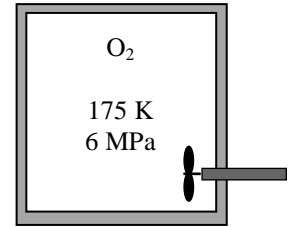

Then,

$$Pv = ZRT \longrightarrow v_1 = \frac{(0.682)(0.2598 \text{ kPa}\cdot\text{m}^3/\text{kg}\cdot\text{K})(175 \text{ K})}{6000 \text{ kPa}} = 0.00516 \text{ m}^3/\text{kg}$$

$$m = \frac{V}{v_1} = \frac{0.05 \text{ m}^3}{0.00516 \text{ m}^3/\text{kg}} = 9.68 \text{ kg}$$

The specific volume of oxygen remains constant during this process, $v_2 = v_1$. Thus,

$$\left. \begin{aligned} T_{R2} &= \frac{T_2}{T_{cr}} = \frac{225}{154.8} = 1.46 \\ v_{R2} &= \frac{v_2}{RT_{cr}/P_{cr}} = \frac{0.00516 \text{ m}^3/\text{kg}}{(0.2598 \text{ kPa}\cdot\text{m}^3/\text{kg}\cdot\text{K})(154.6 \text{ K})/(5043 \text{ kPa})} = 0.649 \end{aligned} \right\} \begin{aligned} Z_2 &= 0.853 \\ Z_{h2} &= 1.09 \\ P_{R2} &= 1.91 \end{aligned}$$

$$P_2 = P_{R2} P_{cr} = (1.91)(5043) = \mathbf{9652 \text{ kPa}}$$

(b) The energy balance relation for this closed system can be expressed as

$$E_{in} - E_{out} = \Delta E_{system}$$

$$W_{in} = \Delta U = m(u_2 - u_1)$$

$$W_{in} = m[h_2 - h_1 - (P_2 v_2 - P_1 v_1)] = m[h_2 - h_1 - R(Z_2 T_2 - Z_1 T_1)]$$

where

$$\begin{aligned} h_2 - h_1 &= RT_{cr}(Z_{h1} - Z_{h2}) + (h_2 - h_1)_{ideal} \\ &= (0.2598)(154.6)(1.33 - 1.09) + 52.96 \\ &= 62.51 \text{ kJ/kg} \end{aligned}$$

Substituting,

$$W_{in} = (9.68 \text{ kg})[62.51 - (0.2598 \text{ kJ/kg}\cdot\text{K})\{(0.853)(225) - (0.682)(175)\}\text{K}] = \mathbf{423 \text{ kJ}}$$

Discussion The following routine in EES is used to get the solution above. Reading values from Fig. A-15 and A-29 together with properties in the book could yield different results.

"Given"

V=0.05 [m^3]
T1=175 [K]
P1=6000 [kPa]
T2=225 [K]

"Properties"

Fluid\$='O2'

$R_u=8.314$ [kJ/kmol-K]
 $T_{cr}=T_{CRIT}(\text{Fluid}\$)$
 $P_{cr}=P_{CRIT}(\text{Fluid}\$)$
 $MM=\text{molarmass}(\text{Fluid}\$)$
 $R=R_u/MM$

"Analysis"

"(a)"

$T_{R1}=T1/T_{cr}$
 $P_{R1}=P1/P_{cr}$
 $Z_{h1}=\text{ENTHDEP}(T_{R1}, P_{R1})$ "the function that returns enthalpy departure factor at T_{R1} and P_{R1} "
 $Z_1=\text{COMPRESS}(T_{R1}, P_{R1})$ "the function that returns compressibility factor at T_{R1} and P_{R1} "
 $T_{R2}=T2/T_{cr}$
 $v_{R2}=(v2*P_{cr})/(R*T_{cr})$
 $v1=Z_1*R*T1/P1$
 $m=V/v1$
 $v2=v1$
 $Z_{h2}=\text{ENTHDEP}(T_{R2}, P_{R2})$ "the function that returns enthalpy departure factor at T_{R2} and P_{R2} "
 $Z_2=\text{COMPRESS}(T_{R2}, P_{R2})$ "the function that returns compressibility factor at T_{R2} and P_{R2} "
 $P2=Z_2*R*T2/v2$
 $P2=P_{R2}*P_{cr}$

"(b)"

$h1_{ideal}=\text{enthalpy}(\text{Fluid}\$, T=T1)$
 $h2_{ideal}=\text{enthalpy}(\text{Fluid}\$, T=T2)$
 $\text{DELTA}h_{ideal}=(h2_{ideal}-h1_{ideal})$
 $\text{DELTA}h=R*T_{cr}*(Z_{h1}-Z_{h2})+\text{DELTA}h_{ideal}$
 $\text{DELTA}u=\text{DELTA}h-R*(Z_2*T2-Z_1*T1)$
 $W_{in}=m*\text{DELTA}u$

Solution

$\text{DELTA}h=62.51$ [kJ/kg]	$T1=175$ [K]
$\text{DELTA}h_{ideal}=52.96$ [kJ/kg]	$T2=225$ [K]
$\text{DELTA}u=43.65$ [kJ/kg]	$T_{cr}=154.6$ [K]
$\text{Fluid}\$='O2'$	$T_{R1}=1.132$
$h1_{ideal}=-121.8$ [kJ/kg]	$T_{R2}=1.456$
$h2_{ideal}=-68.8$ [kJ/kg]	$V=0.05$ [m ³]
$m=9.682$ [kg]	$v1=0.005164$ [m ³ /kg]
$MM=32$ [kg/kmol]	$v2=0.005164$ [m ³ /kg]
$P1=6000$ [kPa]	$v_{R2}=0.6485$
$P2=9652$ [kPa]	$W_{in}=422.6$ [kJ]
$P_{cr}=5043$ [kPa]	$Z_1=0.6815$
$P_{R1}=1.19$	$Z_2=0.8527$
$P_{R2}=1.914$	$Z_{h1}=1.331$
$R=0.2598$ [kJ/kg-K]	$Z_{h2}=1.094$
$R_u=8.314$ [kJ/kmol-K]	

Review Problems

12-80 The relations for Δu , Δh , and Δs of a gas that obeys the equation of state $(P+a/v^2)v = RT$ for an isothermal process are to be derived.

Analysis (a) For an isothermal process $dT = 0$ and the general relation for Δu reduces to

$$\Delta u = u_2 - u_1 = \int_{T_1}^{T_2} c_v dT + \int_{v_1}^{v_2} \left(T \left(\frac{\partial P}{\partial T} \right)_v - P \right) dv = \int_{v_1}^{v_2} \left(T \left(\frac{\partial P}{\partial T} \right)_v - P \right) dv$$

For this gas the equation of state can be expressed as

$$P = \frac{RT}{v} - \frac{a}{v^2} \longrightarrow \left(\frac{\partial P}{\partial T} \right)_v = \frac{R}{v}$$

Thus,

$$T \left(\frac{\partial P}{\partial T} \right)_v - P = \frac{RT}{v} - \frac{RT}{v} + \frac{a}{v^2} = \frac{a}{v^2}$$

Substituting,

$$\Delta u = \int_{v_1}^{v_2} \frac{a}{v^2} dv = a \left(\frac{1}{v_1} - \frac{1}{v_2} \right)$$

(b) The enthalpy change Δh is related to Δu through the relation

$$\Delta h = \Delta u + P_2 v_2 - P_1 v_1$$

where

$$Pv = RT - \frac{a}{v}$$

Thus,

$$P_2 v_2 - P_1 v_1 = \left(RT - \frac{a}{v_2} \right) - \left(RT - \frac{a}{v_1} \right) = a \left(\frac{1}{v_1} - \frac{1}{v_2} \right)$$

Substituting,

$$\Delta h = 2a \left(\frac{1}{v_1} - \frac{1}{v_2} \right)$$

(c) For an isothermal process $dT = 0$ and the general relation for Δs reduces to

$$\Delta s = s_2 - s_1 = \int_{T_1}^{T_2} \frac{c_v}{T} dT + \int_{v_1}^{v_2} \left(\frac{\partial P}{\partial T} \right)_v dv = \int_{v_1}^{v_2} \left(\frac{\partial P}{\partial T} \right)_v dv$$

Substituting $(\partial P/\partial T)_v = R/v$,

$$\Delta s = \int_{v_1}^{v_2} \frac{R}{v} dv = R \ln \frac{v_2}{v_1}$$

12-81 It is to be shown that the slope of a constant-pressure line on an h - s diagram is constant in the saturation region and increases with temperature in the superheated region.

Analysis For $P = \text{constant}$, $dP = 0$ and the given relation reduces to $dh = Tds$, which can also be expressed as

$$\left(\frac{\partial h}{\partial s}\right)_P = T$$

Thus the slope of the $P = \text{constant}$ lines on an h - s diagram is equal to the temperature.

(a) In the saturation region, $T = \text{constant}$ for $P = \text{constant}$ lines, and the slope remains constant.

(b) In the superheat region, the slope increases with increasing temperature since the slope is equal temperature.

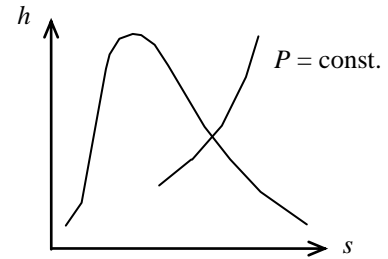

12-82 It is to be shown that

$$c_v = -T \left(\frac{\partial v}{\partial T}\right)_s \left(\frac{\partial P}{\partial T}\right)_v \quad \text{and} \quad c_p = T \left(\frac{\partial P}{\partial T}\right)_s \left(\frac{\partial v}{\partial T}\right)_P$$

Analysis Using the definition of c_v ,

$$c_v = T \left(\frac{\partial s}{\partial T}\right)_v = T \left(\frac{\partial s}{\partial P}\right)_v \left(\frac{\partial P}{\partial T}\right)_v$$

Substituting the first Maxwell relation $\left(\frac{\partial s}{\partial P}\right)_v = -\left(\frac{\partial v}{\partial T}\right)_s$,

$$c_v = -T \left(\frac{\partial v}{\partial T}\right)_s \left(\frac{\partial P}{\partial T}\right)_v$$

Using the definition of c_p ,

$$c_p = T \left(\frac{\partial s}{\partial T}\right)_P = T \left(\frac{\partial s}{\partial v}\right)_P \left(\frac{\partial v}{\partial T}\right)_P$$

Substituting the second Maxwell relation $\left(\frac{\partial s}{\partial v}\right)_P = \left(\frac{\partial P}{\partial T}\right)_s$,

$$c_p = T \left(\frac{\partial P}{\partial T}\right)_s \left(\frac{\partial v}{\partial T}\right)_P$$

12-83 It is to be proven that for a simple compressible substance $\left(\frac{\partial s}{\partial \nu}\right)_u = \frac{P}{T}$.

Analysis The proof is simply obtained as

$$\left(\frac{\partial s}{\partial \nu}\right)_u = \frac{-\left(\frac{\partial u}{\partial \nu}\right)_s}{\left(\frac{\partial u}{\partial s}\right)_\nu} = -\frac{-P}{T} = \frac{P}{T}$$

12-84 It is to be proven by using the definitions of pressure and temperature, $T = \left(\frac{\partial u}{\partial s}\right)_\nu$ and $P = -\left(\frac{\partial u}{\partial \nu}\right)_s$ that for ideal gases, the development of the constant-pressure specific heat yields $\left(\frac{\partial h}{\partial P}\right)_T = 0$

Analysis The definition for enthalpy is

$$h = u + P\nu$$

Then,

$$\left(\frac{\partial h}{\partial P}\right)_T = \left(\frac{\partial u}{\partial P}\right)_T + P\left(\frac{\partial \nu}{\partial P}\right)_T + \nu\left(\frac{\partial P}{\partial P}\right)_T$$

Assume $u = u(s, \nu)$

Then,

$$\begin{aligned} du &= \left(\frac{\partial u}{\partial s}\right)_\nu ds + \left(\frac{\partial u}{\partial \nu}\right)_s d\nu \\ \left(\frac{\partial u}{\partial P}\right)_T &= \left(\frac{\partial u}{\partial s}\right)_\nu \left(\frac{\partial s}{\partial P}\right)_T + \left(\frac{\partial u}{\partial \nu}\right)_s \left(\frac{\partial \nu}{\partial P}\right)_T \\ \left(\frac{\partial u}{\partial P}\right)_T &= T \left[-\left(\frac{\partial \nu}{\partial T}\right)_P \right] - P \left(\frac{\partial \nu}{\partial P}\right)_T = -(T + P) \left(\frac{\partial \nu}{\partial P}\right)_T \\ \left(\frac{\partial h}{\partial P}\right)_T &= -(T + P) \left(\frac{\partial \nu}{\partial P}\right)_T + P \left(\frac{\partial \nu}{\partial P}\right)_T + \nu = -T \left(\frac{\partial \nu}{\partial P}\right)_T + \nu \end{aligned}$$

For ideal gases

$$\nu = \frac{RT}{P} \quad \text{and} \quad \left(\frac{\partial \nu}{\partial P}\right)_T = -\frac{R}{P}$$

Then,

$$\left(\frac{\partial h}{\partial P}\right)_T = -\frac{TR}{P} + \nu = -\nu + \nu = 0$$

12-85 It is to be shown that the position of the Joule-Thompson coefficient inversion curve on the T - P plane is given by $(\partial Z/\partial T)_P = 0$.

Analysis The inversion curve is the locus of the points at which the Joule-Thompson coefficient μ is zero,

$$\mu = \frac{1}{c_p} \left(T \left(\frac{\partial \nu}{\partial T} \right)_P - \nu \right) = 0$$

which can also be written as

$$T \left(\frac{\partial \nu}{\partial T} \right)_P - \frac{ZRT}{P} = 0 \quad (a)$$

since it is given that

$$\nu = \frac{ZRT}{P} \quad (b)$$

Taking the derivative of (b) with respect to T holding P constant gives

$$\left(\frac{\partial \nu}{\partial T} \right)_P = \left(\frac{\partial (ZRT/P)}{\partial T} \right)_P = \frac{R}{P} \left(T \left(\frac{\partial Z}{\partial T} \right)_P + Z \right)$$

Substituting in (a),

$$\begin{aligned} \frac{TR}{P} \left(T \left(\frac{\partial Z}{\partial T} \right)_P + Z \right) - \frac{ZRT}{P} &= 0 \\ T \left(\frac{\partial Z}{\partial T} \right)_P + Z - Z &= 0 \\ \left(\frac{\partial Z}{\partial T} \right)_P &= 0 \end{aligned}$$

which is the desired relation.

12-86 It is to be shown that $\frac{d\nu}{\nu} = \beta dT - \alpha dP$. Also, a relation is to be obtained for the ratio of specific volumes ν_2/ν_1 as a homogeneous system undergoes a process from state 1 to state 2.

Analysis We take $\nu = \nu(P, T)$. Its total differential is

$$d\nu = \left(\frac{\partial \nu}{\partial T}\right)_P dT + \left(\frac{\partial \nu}{\partial P}\right)_T dP$$

Dividing by ν ,

$$\frac{d\nu}{\nu} = \frac{1}{\nu} \left(\frac{\partial \nu}{\partial T}\right)_P dT + \frac{1}{\nu} \left(\frac{\partial \nu}{\partial P}\right)_T dP$$

Using the definitions of α and β ,

$$\frac{d\nu}{\nu} = \beta dT - \alpha dP$$

Taking α and β to be constants, integration from 1 to 2 yields

$$\ln \frac{\nu_2}{\nu_1} = \beta(T_2 - T_1) - \alpha(P_2 - P_1)$$

which is the desired relation.

12-87 It is to be shown that $\frac{d\nu}{\nu} = \beta dT - \alpha dP$. Also, a relation is to be obtained for the ratio of specific volumes ν_2/ν_1 as a homogeneous system undergoes an isobaric process from state 1 to state 2.

Analysis We take $\nu = \nu(P, T)$. Its total differential is

$$d\nu = \left(\frac{\partial \nu}{\partial T}\right)_P dT + \left(\frac{\partial \nu}{\partial P}\right)_T dP$$

which, for a constant pressure process, reduces to

$$d\nu = \left(\frac{\partial \nu}{\partial T}\right)_P dT$$

Dividing by ν ,

$$\frac{d\nu}{\nu} = \frac{1}{\nu} \left(\frac{\partial \nu}{\partial T}\right)_P dT$$

Using the definition of β ,

$$\frac{d\nu}{\nu} = \beta dT$$

Taking β to be a constant, integration from 1 to 2 yields

$$\ln \frac{\nu_2}{\nu_1} = \beta(T_2 - T_1)$$

or

$$\frac{\nu_2}{\nu_1} = \exp[\beta(T_2 - T_1)]$$

which is the desired relation.

12-88 It is to be shown that for an isentropic expansion or compression process $P\nu^k = \text{constant}$. It is also to be shown that the isentropic expansion exponent k reduces to the specific heat ratio c_p/c_ν for an ideal gas.

Analysis We note that $ds = 0$ for an isentropic process. Taking $s = s(P, \nu)$, the total differential ds can be expressed as

$$ds = \left(\frac{\partial s}{\partial P}\right)_\nu dP + \left(\frac{\partial s}{\partial \nu}\right)_P d\nu = 0 \quad (a)$$

We now substitute the Maxwell relations below into (a)

$$\left(\frac{\partial s}{\partial P}\right)_\nu = -\left(\frac{\partial \nu}{\partial T}\right)_s \quad \text{and} \quad \left(\frac{\partial s}{\partial \nu}\right)_P = \left(\frac{\partial P}{\partial T}\right)_s$$

to get

$$-\left(\frac{\partial \nu}{\partial T}\right)_s dP + \left(\frac{\partial P}{\partial T}\right)_s d\nu = 0$$

Rearranging,

$$dP - \left(\frac{\partial T}{\partial \nu}\right)_s \left(\frac{\partial P}{\partial T}\right)_s d\nu = 0 \longrightarrow dP - \left(\frac{\partial P}{\partial \nu}\right)_s d\nu = 0$$

$$\text{Dividing by } P, \quad \frac{dP}{P} - \frac{1}{P} \left(\frac{\partial P}{\partial \nu}\right)_s d\nu = 0 \quad (b)$$

We now define isentropic expansion exponent k as

$$k = -\frac{\nu}{P} \left(\frac{\partial P}{\partial \nu}\right)_s$$

Substituting in (b),

$$\frac{dP}{P} + k \frac{d\nu}{\nu} = 0$$

Taking k to be a constant and integrating,

$$\ln P + k \ln \nu = \text{constant} \longrightarrow \ln P\nu^k = \text{constant}$$

Thus,

$$P\nu^k = \text{constant}$$

To show that $k = c_p/c_\nu$ for an ideal gas, we write the cyclic relations for the following two groups of variables:

$$(s, T, \nu) \longrightarrow \left(\frac{\partial s}{\partial T}\right)_\nu \left(\frac{\partial \nu}{\partial s}\right)_T \left(\frac{\partial T}{\partial \nu}\right)_s = -1 \longrightarrow \frac{c_\nu}{T} \left(\frac{\partial \nu}{\partial s}\right)_T \left(\frac{\partial T}{\partial \nu}\right)_s = -1 \quad (c)$$

$$(s, T, P) \longrightarrow \left(\frac{\partial s}{\partial T}\right)_P \left(\frac{\partial P}{\partial s}\right)_T \left(\frac{\partial T}{\partial P}\right)_s = -1 \longrightarrow \frac{c_p}{T} \left(\frac{\partial P}{\partial s}\right)_T \left(\frac{\partial T}{\partial P}\right)_s = -1 \quad (d)$$

where we used the relations

$$c_\nu = T \left(\frac{\partial s}{\partial T}\right)_\nu \quad \text{and} \quad c_p = T \left(\frac{\partial s}{\partial T}\right)_P$$

Setting Eqs. (c) and (d) equal to each other,

$$\frac{c_p}{T} \left(\frac{\partial P}{\partial s}\right)_T \left(\frac{\partial T}{\partial P}\right)_s = \frac{c_\nu}{T} \left(\frac{\partial \nu}{\partial s}\right)_T \left(\frac{\partial T}{\partial \nu}\right)_s$$

or,

$$\frac{c_p}{c_\nu} = \left(\frac{\partial s}{\partial P}\right)_T \left(\frac{\partial P}{\partial T}\right)_s \left(\frac{\partial \nu}{\partial s}\right)_T \left(\frac{\partial T}{\partial \nu}\right)_s = \left(\frac{\partial s}{\partial P} \frac{\partial \nu}{\partial s}\right)_T \left(\frac{\partial P}{\partial T} \frac{\partial T}{\partial \nu}\right)_s = \left(\frac{\partial \nu}{\partial P}\right)_T \left(\frac{\partial P}{\partial \nu}\right)_s$$

but

$$\left(\frac{\partial \nu}{\partial P}\right)_T = \left(\frac{\partial (RT/P)}{\partial P}\right)_T = -\frac{\nu}{P}$$

Substituting,

$$\frac{c_p}{c_\nu} = -\frac{\nu}{P} \left(\frac{\partial P}{\partial \nu}\right)_s = k$$

which is the desired relation.

12-89 The c_p of nitrogen at 300 kPa and 400 K is to be estimated using the relation given and its definition, and the results are to be compared to the value listed in Table A-2b.

Analysis (a) We treat nitrogen as an ideal gas with $R = 0.297$ kJ/kg·K and $k = 1.397$. Note that $PT^{-k/(k-1)} = C = \text{constant}$ for the isentropic processes of ideal gases. The c_p relation is given as

$$c_p = T \left(\frac{\partial P}{\partial T} \right)_s \left(\frac{\partial v}{\partial T} \right)_p$$

$$v = \frac{RT}{P} \longrightarrow \left(\frac{\partial v}{\partial T} \right)_p = \frac{R}{P}$$

$$P = CT^{k/(k-1)} \longrightarrow \left(\frac{\partial P}{\partial T} \right)_s = \frac{k}{k-1} CT^{k/(k-1)-1} = \frac{k}{k-1} (PT^{-k/(k-1)}) T^{k/(k-1)-1} = \frac{kP}{T(k-1)}$$

Substituting,

$$c_p = T \left(\frac{kP}{T(k-1)} \right) \left(\frac{R}{P} \right) = \frac{kR}{k-1} = \frac{1.397(0.297 \text{ kJ/kg} \cdot \text{K})}{1.397-1} = 1.045 \text{ kJ/kg} \cdot \text{K}$$

(b) The c_p is defined as $c_p = \left(\frac{\partial h}{\partial T} \right)_p$. Replacing the differentials by differences,

$$c_p \cong \left(\frac{\Delta h}{\Delta T} \right)_{P=300\text{kPa}} = \frac{h(410 \text{ K}) - h(390 \text{ K})}{(410 - 390)\text{K}} = \frac{(11,932 - 11,347)/28.0 \text{ kJ/kg}}{(410 - 390)\text{K}} = \mathbf{1.045 \text{ kJ/kg} \cdot \text{K}}$$

(Compare: Table A-2b at 400 K $\rightarrow c_p = 1.044$ kJ/kg·K)

12-90 The temperature change of steam and the average Joule-Thomson coefficient during a throttling process are to be estimated.

Analysis The enthalpy of steam at 2.5 MPa and $T = 400^\circ\text{C}$ is $h = 3240.1$ kJ/kg. Now consider a throttling process from this state to 1.2 MPa. The temperature of the steam at the end of this throttling process will be

$$\left. \begin{array}{l} P = 1.2 \text{ MPa} \\ h = 3240.1 \text{ kJ/kg} \end{array} \right\} T_2 = 390.10^\circ\text{C}$$

Thus the temperature drop during this throttling process is

$$\Delta T = T_2 - T_1 = 390.10 - 400 = \mathbf{-9.90^\circ\text{C}}$$

The average Joule-Thomson coefficient for this process is determined from

$$\mu = \left(\frac{\partial T}{\partial P} \right)_h \cong \left(\frac{\Delta T}{\Delta P} \right)_{h=3240.1\text{kJ/kg}} = \frac{(390.10 - 400)^\circ\text{C}}{(1.2 - 2.5)\text{MPa}} = \mathbf{7.61^\circ\text{C/MPa}}$$

12-91 The volume expansivity of copper is given at two temperatures. The percent change in the volume of copper when it is heated at atmospheric pressure is to be determined.

Properties The volume expansivity of copper is given to be $49.2 \times 10^{-6} \text{ K}^{-1}$ at 300 K, and be $54.2 \times 10^{-6} \text{ K}^{-1}$ at 500 K

Analysis We take $\nu = \nu(P, T)$. Its total differential is

$$d\nu = \left(\frac{\partial \nu}{\partial T} \right)_P dT + \left(\frac{\partial \nu}{\partial P} \right)_T dP$$

which, for a constant pressure process, reduces to

$$d\nu = \left(\frac{\partial \nu}{\partial T} \right)_P dT$$

Dividing by ν and using the definition of β ,

$$\frac{d\nu}{\nu} = \frac{1}{\nu} \left(\frac{\partial \nu}{\partial T} \right)_P dT = \beta dT$$

Taking β to be a constant, integration from 1 to 2 yields

$$\ln \frac{\nu_2}{\nu_1} = \beta(T_2 - T_1)$$

or

$$\frac{\nu_2}{\nu_1} = \exp[\beta(T_2 - T_1)]$$

The average value of β is

$$\beta_{\text{ave}} = (\beta_1 + \beta_2)/2 = (49.2 \times 10^{-6} + 54.2 \times 10^{-6})/2 = 51.7 \times 10^{-6} \text{ K}^{-1}$$

Substituting the given values,

$$\frac{\nu_2}{\nu_1} = \exp[\beta(T_2 - T_1)] = \exp[(51.7 \times 10^{-6} \text{ K}^{-1})(500 - 300)\text{K}] = 1.0104$$

Therefore, the volume of copper block will increase by **1.04 percent**.

12-92 An adiabatic storage tank that is initially evacuated is connected to a supply line that carries nitrogen. A valve is opened, and nitrogen flows into the tank. The final temperature in the tank is to be determined by treating nitrogen as an ideal gas and using the generalized charts, and the results are to be compared to the given actual value.

Assumptions 1 Uniform flow conditions exist. 2 Kinetic and potential energies are negligible.

Analysis We take the tank as the system, which is a control volume since mass crosses the boundary. Noting that the microscopic energies of flowing and nonflowing fluids are represented by enthalpy h and internal energy u , respectively, the mass and energy balances for this uniform-flow system can be expressed as

$$\text{Mass balance: } m_{\text{in}} - m_{\text{out}} = \Delta m_{\text{system}} \rightarrow m_i = m_2 \quad (\text{since } m_{\text{out}} = m_{\text{initial}} = 0)$$

$$\text{Energy balance: } E_{\text{in}} - E_{\text{out}} = \Delta E_{\text{system}} \rightarrow 0 + m_i h_i = m_2 u_2$$

$$\text{Combining the two balances: } u_2 = h_i$$

(a) From the ideal gas property table of nitrogen, at 225 K we read

$$\bar{u}_2 = \bar{h}_i = \bar{h}_{@225 \text{ K}} = 6,537 \text{ kJ/kmol}$$

The temperature that corresponds to this \bar{u}_2 value is

$$T_2 = \mathbf{314.8 \text{ K}} \quad (7.4\% \text{ error})$$

(b) Using the generalized enthalpy departure chart, h_i is determined to be

$$\left. \begin{aligned} T_{R,i} &= \frac{T_i}{T_{\text{cr}}} = \frac{225}{126.2} = 1.78 \\ P_{R,i} &= \frac{P_i}{P_{\text{cr}}} = \frac{10}{3.39} = 2.95 \end{aligned} \right\} Z_{h,i} = \frac{\bar{h}_{i,\text{ideal}} - \bar{h}_i}{R_u T_{\text{cr}}} = 0.9 \quad (\text{Fig. A-29})$$

Thus,

$$\bar{h}_i = \bar{h}_{i,\text{ideal}} - 0.9 R_u T_{\text{cr}} = 6,537 - (0.9)(8.314)(126.2) = 5,593 \text{ kJ/kmol}$$

and

$$\bar{u}_2 = \bar{h}_i = 5,593 \text{ kJ/kmol}$$

Try $T_2 = 280 \text{ K}$. Then at $P_{R2} = 2.95$ and $T_{R2} = 2.22$ we read $Z_2 = 0.98$ and $(\bar{h}_{2,\text{ideal}} - \bar{h}_2) / R_u T_{\text{cr}} = 0.55$

Thus,

$$\bar{h}_2 = \bar{h}_{2,\text{ideal}} - 0.55 R_u T_{\text{cr}} = 8,141 - (0.55)(8.314)(126.2) = 7,564 \text{ kJ/kmol}$$

$$\bar{u}_2 = \bar{h}_2 - Z R_u T_2 = 7,564 - (0.98)(8.314)(280) = 5,283 \text{ kJ/kmol}$$

Try $T_2 = 300 \text{ K}$. Then at $P_{R2} = 2.95$ and $T_{R2} = 2.38$ we read $Z_2 = 1.0$ and $(\bar{h}_{2,\text{ideal}} - \bar{h}_2) / R_u T_{\text{cr}} = 0.50$

Thus,

$$\bar{h}_2 = \bar{h}_{2,\text{ideal}} - 0.50 R_u T_{\text{cr}} = 8,723 - (0.50)(8.314)(126.2) = 8,198 \text{ kJ/kmol}$$

$$\bar{u}_2 = \bar{h}_2 - Z R_u T_2 = 8,198 - (1.0)(8.314)(300) = 5,704 \text{ kJ/kmol}$$

By linear interpolation,

$$T_2 = \mathbf{294.7 \text{ K}} \quad (0.6\% \text{ error})$$

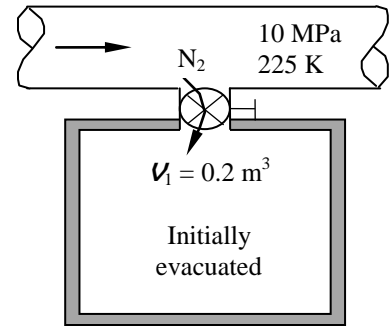

12-93E Argon gas enters a turbine at a specified state and leaves at another specified state. The power output of the turbine and the exergy destruction associated with the process are to be determined using the generalized charts.

Properties The gas constant and critical properties of argon are $R = 0.04971 \text{ Btu/lbm}\cdot\text{R}$, $T_{cr} = 272 \text{ R}$, and $P_{cr} = 705 \text{ psia}$ (Table A-1E).

Analysis (a) The enthalpy and entropy departures of argon at the specified states are determined from the generalized charts to be

$$\left. \begin{aligned} T_{R_1} &= \frac{T_1}{T_{cr}} = \frac{1000}{272} = 3.68 \\ P_{R_1} &= \frac{P_1}{P_{cr}} = \frac{1000}{705} = 1.418 \end{aligned} \right\} Z_{h_1} \cong 0 \text{ and } Z_{s_1} \cong 0$$

Thus argon behaves as an ideal gas at turbine inlet. Also,

$$\left. \begin{aligned} T_{R_2} &= \frac{T_2}{T_{cr}} = \frac{500}{272} = 1.838 \\ P_{R_2} &= \frac{P_2}{P_{cr}} = \frac{150}{705} = 0.213 \end{aligned} \right\} Z_{h_2} = 0.04 \text{ and } Z_{s_2} = 0.02$$

Thus,

$$\begin{aligned} h_2 - h_1 &= RT_{cr} (Z_{h_1} - Z_{h_2}) + (h_2 - h_1)_{ideal} \\ &= (0.04971)(272)(0 - 0.04) + 0.1253(500 - 1000) = -63.2 \text{ Btu/lbm} \end{aligned}$$

The power output of the turbine is to be determined from the energy balance equation,

$$\begin{aligned} \dot{E}_{in} - \dot{E}_{out} &= \Delta \dot{E}_{system} = 0 \text{ (steady)} \rightarrow \dot{E}_{in} = \dot{E}_{out} \\ \dot{m}(h_1 + V_1^2/2) &= \dot{m}(h_2 + V_2^2/2) + \dot{Q}_{out} + \dot{W}_{out} \rightarrow \dot{W}_{out} = -\dot{m} \left[(h_2 - h_1) + \frac{V_2^2 - V_1^2}{2} \right] - \dot{Q}_{out} \\ \dot{W}_{out} &= -(12 \text{ lbm/s}) \left(-63.2 + \frac{(450 \text{ ft/s})^2 - (300 \text{ ft/s})^2}{2} \left(\frac{1 \text{ Btu/lbm}}{25,037 \text{ ft}^2/\text{s}^2} \right) \right) - 80 \text{ Btu/s} \\ &= \mathbf{651.4 \text{ Btu/s} = 922 \text{ hp}} \end{aligned}$$

(b) Under steady conditions, the rate form of the entropy balance for the turbine simplifies to

$$\begin{aligned} \dot{S}_{in} - \dot{S}_{out} + \dot{S}_{gen} &= \Delta \dot{S}_{system} \stackrel{\approx 0}{=} 0 \\ \dot{m}s_1 - \dot{m}s_2 - \frac{\dot{Q}_{out}}{T_{b,out}} + \dot{S}_{gen} &= 0 \rightarrow \dot{S}_{gen} = \dot{m}(s_2 - s_1) + \frac{\dot{Q}_{out}}{T_0} \end{aligned}$$

The exergy destroyed during a process can be determined from an exergy balance or directly from its definition $\dot{X}_{destroyed} = T_0 \dot{S}_{gen}$,

$$\dot{X}_{destroyed} = T_0 \dot{S}_{gen} = T_0 \left(\dot{m}(s_2 - s_1) + \frac{\dot{Q}_{out}}{T_0} \right)$$

where $s_2 - s_1 = R(Z_{s_1} - Z_{s_2}) + (s_2 - s_1)_{ideal}$

and $(s_2 - s_1)_{ideal} = c_p \ln \frac{T_2}{T_1} - R \ln \frac{P_2}{P_1} = 0.1253 \ln \frac{500}{1000} - 0.04971 \ln \frac{150}{1000} = 0.00745 \text{ Btu/lbm}\cdot\text{R}$

Thus $s_2 - s_1 = R(Z_{s_1} - Z_{s_2}) + (s_2 - s_1)_{ideal} = (0.04971)[0 - (0.02)] + 0.00745 = 0.00646 \text{ Btu/lbm}\cdot\text{R}$

Substituting,

$$\dot{X}_{destroyed} = (535 \text{ R}) \left((12 \text{ lbm/s})(0.00646 \text{ Btu/lbm}\cdot\text{R}) + \frac{80 \text{ Btu/s}}{535 \text{ R}} \right) = 121.5 \text{ Btu/s} \cong \mathbf{122 \text{ Btu/s}}$$

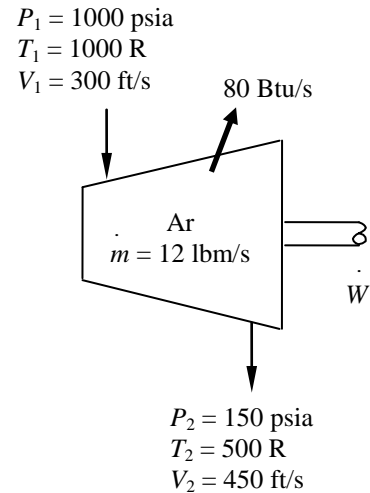

12-94E Methane is to be adiabatically and reversibly compressed in a steady-flow device. The specific work required for this compression is to be determined using the departure charts and treating the methane as an ideal gas with temperature variable specific heats.

Properties The properties of methane are (Table A-1E)

$$M = 16.043 \text{ lbm/lbmol}, R = 0.1238 \text{ Btu/lbm} \cdot \text{R}, T_{\text{cr}} = 343.9 \text{ R}, P_{\text{cr}} = 673 \text{ psia}$$

Analysis The temperature at the exit state may be determined by the fact that the process is isentropic and the molar entropy change between the inlet and exit is zero. When the expression of Table A-2E is substituted for c_p and the integration performed, we obtain

$$\begin{aligned} (\bar{s}_2 - \bar{s}_1)_{\text{ideal}} &= \int_1^2 \frac{c_p}{T} dT - R_u \ln \frac{P_2}{P_1} = \int_1^2 \left(\frac{a}{T} + b + cT + dT^2 \right) dT - R_u \ln \frac{P_2}{P_1} \\ &= a \ln \frac{T_2}{T_1} + b(T_2 - T_1) + \frac{c}{2}(T_2^2 - T_1^2) + \frac{d}{3}(T_2^3 - T_1^3) - R_u \ln \frac{P_2}{P_1} \end{aligned}$$

Substituting,

$$\begin{aligned} 0 &= 4.75 \ln \frac{T_2}{560} + 0.006666(T_2 - 560) + \frac{0.09352 \times 10^{-5}}{2}(T_2^2 - 560^2) \\ &\quad - \frac{0.4510 \times 10^{-9}}{3}(T_2^3 - 560^3) - (1.9858) \ln \frac{500}{50} \end{aligned}$$

Solving this equation by EES or an iterative solution gives

$$T_2 = 892 \text{ R}$$

When an energy balance is applied to the compressor, it becomes

$$\begin{aligned} \bar{w}_{\text{in}} &= (\bar{h}_2 - \bar{h}_1)_{\text{ideal}} = \int_1^2 c_p dT = \int_1^2 (a + bT + cT^2 + dT^3) dT \\ &= a(T_2 - T_1) + \frac{b}{2}(T_2^2 - T_1^2) + \frac{c}{3}(T_2^3 - T_1^3) + \frac{d}{4}(T_2^4 - T_1^4) \\ &= 4.75(892 - 560) + \frac{0.006666}{2}(892^2 - 560^2) + \frac{0.09352 \times 10^{-5}}{3}(892^3 - 560^3) \\ &\quad - \frac{0.4510 \times 10^{-9}}{4}(892^4 - 560^4) \\ &= 3290 \text{ Btu/lbmol} \end{aligned}$$

The work input per unit mass basis is

$$w_{\text{in}} = \frac{\bar{w}_{\text{in}}}{M} = \frac{3290 \text{ Btu/lbmol}}{16.043 \text{ lbm/lbmol}} = \mathbf{205.1 \text{ Btu/lbm}}$$

The enthalpy departures of propane at the specified states are determined from the generalized charts to be (Fig. A-29 or from EES)

$$\left. \begin{aligned} T_{R1} &= \frac{T_1}{T_{\text{cr}}} = \frac{560}{343.9} = 1.628 \\ P_{R1} &= \frac{P_1}{P_{\text{cr}}} = \frac{50}{673} = 0.0743 \end{aligned} \right\} \longrightarrow Z_{h1} = 0.0332$$

and

$$\left. \begin{aligned} T_{R2} &= \frac{T_2}{T_{\text{cr}}} = \frac{892}{343.9} = 2.594 \\ P_{R2} &= \frac{P_2}{P_{\text{cr}}} = \frac{500}{673} = 0.743 \end{aligned} \right\} \longrightarrow Z_{h2} = 0.0990$$

The work input is determined to be

$$\begin{aligned} w_{\text{in}} &= h_2 - h_1 = (h_2 - h_1)_{\text{ideal}} - RT_{\text{cr}}(Z_{h2} - Z_{h1}) \\ &= 205.1 \text{ Btu/lbm} - (0.1238 \text{ Btu/lbm} \cdot \text{R})(343.9 \text{ R})(0.0990 - 0.0332) \\ &= \mathbf{202.3 \text{ Btu/lbm}} \end{aligned}$$

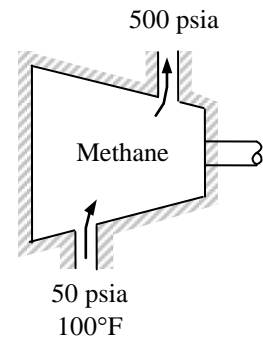

12-95  The work done by the refrigerant 134a as it undergoes an isothermal process in a closed system is to be determined using the tabular (EES) data and the generalized charts.

Analysis The solution using EES built-in property data is as follows:

$$\left. \begin{array}{l} T_1 = 40^\circ\text{C} \\ P_1 = 2 \text{ MPa} \end{array} \right\} \begin{array}{l} u_1 = 106.39 \text{ kJ/kg} \\ s_1 = 0.3917 \text{ kJ/kg}\cdot\text{K} \end{array}$$

$$\left. \begin{array}{l} T_2 = 40^\circ\text{C} \\ P_2 = 0.1 \text{ MPa} \end{array} \right\} \begin{array}{l} u_2 = 264.27 \text{ kJ/kg} \\ s_2 = 1.1485 \text{ kJ/kg}\cdot\text{K} \end{array}$$

$$\Delta s_{\text{EES}} = s_2 - s_1 = 1.1485 - 0.3917 = 0.7568 \text{ kJ/kg}\cdot\text{K}$$

$$q_{\text{EES}} = T_1 \Delta s_{\text{EES}} = (40 + 273.15 \text{ K})(0.7568 \text{ kJ/kg}\cdot\text{K}) = 237.00 \text{ kJ/kg}$$

$$w_{\text{EES}} = q_{\text{EES}} - (u_2 - u_1) = 237.00 - (264.27 - 106.39) = \mathbf{79.1 \text{ kJ/kg}}$$

For the generalized chart solution we first determine the following factors using EES as

$$\left. \begin{array}{l} T_{R1} = \frac{T_1}{T_{cr}} = \frac{313.2}{374.2} = 0.8369 \\ P_{R1} = \frac{P_1}{P_{cr}} = \frac{2}{4.059} = 0.4927 \end{array} \right\} \longrightarrow Z_1 = 0.08357, Z_{h1} = 4.82 \text{ and } Z_{s1} = 5.147$$

$$\left. \begin{array}{l} T_{R2} = \frac{T_2}{T_{cr}} = \frac{313.2}{374.2} = 0.8369 \\ P_{R2} = \frac{P_2}{P_{cr}} = \frac{0.1}{4.059} = 0.02464 \end{array} \right\} \longrightarrow Z_2 = 0.9857, Z_{h2} = 0.03396 \text{ and } Z_{s2} = 0.02635$$

Then,

$$\Delta h_1 = Z_{h1} R T_{cr} = (4.82)(0.08148 \text{ kJ/kg}\cdot\text{K})(374.2 \text{ K}) = 146.97 \text{ kJ/kg}$$

$$\Delta s_1 = Z_{s1} R = (5.147)(0.08148 \text{ kJ/kg}\cdot\text{K}) = 0.4194 \text{ kJ/kg}\cdot\text{K}$$

$$\Delta h_2 = Z_{h2} R T_{cr} = (0.03396)(0.08148 \text{ kJ/kg}\cdot\text{K})(374.2 \text{ K}) = 1.04 \text{ kJ/kg}$$

$$\Delta s_2 = Z_{s2} R = (0.02635)(0.08148 \text{ kJ/kg}\cdot\text{K}) = 0.002147 \text{ kJ/kg}\cdot\text{K}$$

$$\Delta s_{\text{ideal}} = R \ln \frac{P_2}{P_1} = (0.08148 \text{ kJ/kg}\cdot\text{K}) \ln \left(\frac{0.1}{2} \right) = 0.2441 \text{ kJ/kg}\cdot\text{K}$$

$$\Delta s_{\text{chart}} = \Delta s_{\text{ideal}} - (\Delta s_2 - \Delta s_1) = 0.2441 - (0.002147 - 0.4194) = 0.6613 \text{ kJ/kg}\cdot\text{K}$$

$$q_{\text{chart}} = T_1 \Delta s_{\text{chart}} = (40 + 273.15 \text{ K})(0.6613 \text{ kJ/kg}\cdot\text{K}) = 207.09 \text{ kJ/kg}$$

$$\begin{aligned} \Delta u_{\text{chart}} &= \Delta h_{\text{ideal}} - (\Delta h_2 - \Delta h_1) - (Z_2 R T_2 - Z_1 R T_1) \\ &= 0 - (1.04 - 146.97) - [(0.9857)(0.08148)(313.2) - (0.08357)(0.08148)(313.2)] \\ &= 122.92 \text{ kJ/kg} \end{aligned}$$

$$w_{\text{chart}} = q_{\text{chart}} - \Delta u_{\text{chart}} = 207.09 - 122.92 = \mathbf{84.2 \text{ kJ/kg}}$$

The copy of the EES solution of this problem is given next.

"Input data"

T_critical=T_CRIT(R134a) "[K]"

P_critical=P_CRIT(R134a) "[kpa]"

T[1]=40+273.15 "[K]"

T[2]=T[1] "[K]"

```
P[1]=2000"[kPa]"
P[2]=100"[kPa]"
R_u=8.314"[kJ/kmol-K]"
M=molarmass(R134a)
R=R_u/M"[kJ/kg-K]"
```

```
***** SOLUTION USING EES BUILT-IN PROPERTY DATA *****
```

```
"For the isothermal process, the heat transfer is T*(s[2] - s[1]):"
DELTA_s_EES=(entropy(R134a,T=T[2],P=P[2])-entropy(R134a,T=T[1],P=P[1]))
q_EES=T[1]*DELTA_s_EES
```

```
s_2=entropy(R134a,T=T[2],P=P[2])
s_1=entropy(R134a,T=T[1],P=P[1])
```

```
"Conservation of energy for the closed system:"
```

```
DELTA_u_EES=intEnergy(R134a,T=T[2],p=P[2])-intEnergy(R134a,T=T[1],P=P[1])
q_EES-w_EES=DELTA_u_EES
u_1=intEnergy(R134a,T=T[1],P=P[1])
u_2=intEnergy(R134a,T=T[2],p=P[2])
```

```
***** COMPRESSIBILITY CHART SOLUTION *****
```

```
"State 1"
```

```
Tr[1]=T[1]/T_critical
pr[1]=p[1]/p_critical
Z[1]=COMPRESS(Tr[1], Pr[1])
DELTA_h[1]=ENTHDEP(Tr[1], Pr[1])*R*T_critical"Enthalpy departure"
Z_h1=ENTHDEP(Tr[1], Pr[1])
DELTA_s[1]=ENTRDEP(Tr[1], Pr[1])*R "Entropy departure"
Z_s1=ENTRDEP(Tr[1], Pr[1])
```

```
"State 2"
```

```
Tr[2]=T[2]/T_critical
Pr[2]=P[2]/P_critical
Z[2]=COMPRESS(Tr[2], Pr[2])
DELTA_h[2]=ENTHDEP(Tr[2], Pr[2])*R*T_critical"Enthalpy departure"
Z_h2=ENTHDEP(Tr[2], Pr[2])
DELTA_s[2]=ENTRDEP(Tr[2], Pr[2])*R "Entropy departure"
Z_s2=ENTRDEP(Tr[2], Pr[2])
```

```
"Entropy Change"
```

```
DELTA_s_ideal=-R*ln(P[2]/P[1])
DELTA_s_chart=DELTA_s_ideal-(DELTA_s[2]-DELTA_s[1])
```

```
"For the isothermal process, the heat transfer is T*(s[2] - s[1]):"
```

```
q_chart=T[1]*DELTA_s_chart
```

```
"Conservation of energy for the closed system:"
```

```
DELTA_h_ideal=0
DELTA_u_chart=DELTA_h_ideal-(DELTA_h[2]-DELTA_h[1])-(Z[2]*R*T[2]-Z[1]*R*T[1])
q_chart-w_chart=DELTA_u_chart
```

SOLUTION

DELTAh[1]=146.97 [kJ/kg]	R=0.08148 [kJ/kg-K]
DELTAh[2]=1.04 [kJ/kg]	R_u=8.314 [kJ/kmol-K]
DELTAh_ideal=0 [kJ/kg]	s_1=0.3917
DELTA _s [1]=0.4194 [kJ/kg-K]	s_2=1.1485 [kJ/kg-K]
DELTA _s [2]=0.002147 [kJ/kg-K]	T[1]=313.2 [K]
DELTA _s _chart=0.6613 [kJ/kg-K]	T[2]=313.2 [K]
DELTA _s _EES=0.7568 [kJ/kg-K]	Tr[1]=0.8369
DELTA _s _ideal=0.2441 [kJ/kg-K]	Tr[2]=0.8369
DELTA _u _chart=122.92 [kJ/kg]	T_critical=374.2 [K]
DELTA _u _EES=157.9 [kJ/kg]	u_1=106.39
M=102	u_2=264.27 [kJ/kg]
P[1]=2000 [kPa]	w_chart=84.18 [kJ/kg]
P[2]=100 [kPa]	w_EES=79.12 [kJ/kg]
pr[1]=0.4927	Z[1]=0.08357
Pr[2]=0.02464	Z[2]=0.9857
P_critical=4059 [kpa]	Z_h1=4.82
q_chart=207.09 [kJ/kg]	Z_h2=0.03396
q_EES=237.00 [kJ/kg]	Z_s1=5.147
	Z_s2=0.02635

12-96 The initial state and the final temperature of argon contained in a rigid tank are given. The mass of the argon in the tank, the final pressure, and the heat transfer are to be determined using the generalized charts.

Analysis (a) The compressibility factor of argon at the initial state is determined from the generalized chart to be

$$\left. \begin{aligned} T_{R_1} &= \frac{T_1}{T_{cr}} = \frac{173}{151.0} = 1.146 \\ P_{R_1} &= \frac{P_1}{P_{cr}} = \frac{1}{4.86} = 0.206 \end{aligned} \right\} Z_1 = 0.95 \text{ and } Z_{h_1} = 0.18$$

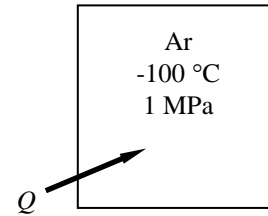

Then,

$$Pv = ZRT \longrightarrow v = \frac{ZRT}{P} = \frac{(0.95)(0.2081 \text{ kPa} \cdot \text{m}^3/\text{kg} \cdot \text{K})(173 \text{ K})}{1000 \text{ kPa}} = 0.0342 \text{ m}^3/\text{kg}$$

$$m = \frac{V}{v} = \frac{1.2 \text{ m}^3}{0.0342 \text{ m}^3/\text{kg}} = \mathbf{35.1 \text{ kg}}$$

(b) The specific volume of argon remains constant during this process, $v_2 = v_1$. Thus,

$$\left. \begin{aligned} T_{R_2} &= \frac{T_2}{T_{cr}} = \frac{273}{151.0} = 1.808 \\ v_{R_2} &= \frac{v_2}{RT_{cr}/P_{cr}} = \frac{0.0342 \text{ m}^3/\text{kg}}{(0.2081 \text{ kPa} \cdot \text{m}^3/\text{kg} \cdot \text{K})(151 \text{ K})(4860 \text{ kPa})} = 5.29 \end{aligned} \right\} \begin{aligned} P_{R_2} &= 0.315 \\ Z_2 &= 0.99 \\ Z_{h_2} &\cong 0 \end{aligned}$$

$$P_2 = P_{R_2} P_{cr} = (0.315)(4860) = 1531 \text{ kPa}$$

(c) The energy balance relation for this closed system can be expressed as

$$\begin{aligned} E_{in} - E_{out} &= \Delta E_{\text{system}} \\ Q_{in} &= \Delta U = m(u_2 - u_1) \\ Q_{in} &= m[h_2 - h_1 - (P_2 v_2 - P_1 v_1)] = m[h_2 - h_1 - R(Z_2 T_2 - Z_1 T_1)] \end{aligned}$$

where

$$h_2 - h_1 = RT_{cr}(Z_{h_1} - Z_{h_2}) + (h_2 - h_1)_{\text{ideal}} = (0.2081)(151)(0.18 - 0) + 0.5203(0 - (-100)) = 57.69 \text{ kJ/kg}$$

Thus,

$$Q_{in} = (35.1 \text{ kg})[57.69 - (0.2081 \text{ kJ/kg} \cdot \text{K})[(0.99)(273) - (0.95)(173)]] = \mathbf{1251 \text{ kJ}}$$

12-97 The heat transfer, work, and entropy changes of methane during a process in a piston-cylinder device are to be determined assuming ideal gas behavior, using generalized charts, and real fluid (EES) data.

Analysis The ideal gas solution: (Properties are obtained from EES)

State 1:

$$\begin{aligned} T_1 &= 100^\circ\text{C} \longrightarrow h_1 = -4473.3 \text{ kJ/kg} \\ T_1 &= 100^\circ\text{C}, P_1 = 5 \text{ MPa} \longrightarrow s_1 = 10.116 \text{ kJ/kg}\cdot\text{K} \\ u_1 &= h_1 - RT_1 = (-4473.3) - (0.5182)(100 + 273.15) = -4666.7 \text{ kJ/kg} \\ \nu_1 &= R \frac{T_1}{P_1} = (0.5182 \text{ kJ/kg}\cdot\text{K}) \left(\frac{100 + 273.15 \text{ K}}{5000 \text{ kPa}} \right) = 0.03868 \text{ m}^3/\text{kg} \end{aligned}$$

State 2:

$$\begin{aligned} T_2 &= 250^\circ\text{C} \longrightarrow h_2 = -4063.0 \text{ kJ/kg} \\ T_2 &= 250^\circ\text{C}, P_2 = 5 \text{ MPa} \longrightarrow s_2 = 11.035 \text{ kJ/kg}\cdot\text{K} \\ u_2 &= h_2 - RT_2 = (-4063.0) - (0.5182)(250 + 273.15) = -4334.1 \text{ kJ/kg} \\ \nu_2 &= R \frac{T_2}{P_2} = (0.5182 \text{ kJ/kg}\cdot\text{K}) \left(\frac{250 + 273.15 \text{ K}}{5000 \text{ kPa}} \right) = 0.05422 \text{ m}^3/\text{kg} \\ w_{\text{ideal}} &= P(\nu_2 - \nu_1) = (5000 \text{ kPa})(0.05422 - 0.03868) \text{ m}^3/\text{kg} = \mathbf{77.73 \text{ kJ/kg}} \\ q_{\text{ideal}} &= w_{\text{ideal}} + (u_2 - u_1) = 77.73 + [(-4334.1) - (-4666.7)] = \mathbf{410.3 \text{ kJ/kg}} \\ \Delta s_{\text{ideal}} &= s_2 - s_1 = 11.035 - 10.116 = \mathbf{0.919 \text{ kJ/kg}} \end{aligned}$$

For the generalized chart solution we first determine the following factors using EES as

$$\left. \begin{aligned} T_{R1} &= \frac{T_1}{T_{\text{cr}}} = \frac{373.2}{304.2} = 1.227 \\ P_{R1} &= \frac{P_1}{P_{\text{cr}}} = \frac{5}{7.39} = 0.6766 \end{aligned} \right\} \longrightarrow Z_1 = 0.8773, Z_{h1} = 0.5493 \text{ and } Z_{s1} = 0.3269$$

$$\left. \begin{aligned} T_{R2} &= \frac{T_2}{T_{\text{cr}}} = \frac{523.2}{304.2} = 1.720 \\ P_{R2} &= \frac{P_2}{P_{\text{cr}}} = \frac{5}{7.39} = 0.6766 \end{aligned} \right\} \longrightarrow Z_2 = 0.9739, Z_{h2} = 0.2676 \text{ and } Z_{s2} = 0.1281$$

State 1:

$$\begin{aligned} \Delta h_1 &= Z_{h1} RT_{\text{cr}} = (0.5493)(0.5182 \text{ kJ/kg}\cdot\text{K})(304.2 \text{ K}) = 86.60 \text{ kJ/kg} \\ h_1 &= h_{1,\text{ideal}} - \Delta h_1 = (-4473.3) - 86.60 = -4559.9 \text{ kJ/kg} \\ u_1 &= h_1 - Z_1 RT_1 = (-4559.9) - (0.8773)(0.5182)(373.15) = -4729.6 \text{ kJ/kg} \\ \nu_1 &= Z_1 R \frac{T_1}{P_1} = (0.8773)(0.5182) \frac{373.15}{5000} = 0.03393 \text{ m}^3/\text{kg} \\ \Delta s_1 &= Z_{s1} R = (0.3269)(0.5182 \text{ kJ/kg}\cdot\text{K}) = 0.1694 \text{ kJ/kg}\cdot\text{K} \\ s_1 &= s_{1,\text{ideal}} - \Delta s_1 = 10.116 - 0.1694 = 9.946 \text{ kJ/kg}\cdot\text{K} \end{aligned}$$

State 2:

$$\begin{aligned} \Delta h_2 &= Z_{h2} RT_{\text{cr}} = (0.2676)(0.5182 \text{ kJ/kg}\cdot\text{K})(304.2 \text{ K}) = 42.19 \text{ kJ/kg} \\ h_2 &= h_{2,\text{ideal}} - \Delta h_2 = (-4063.0) - 42.19 = -4105.2 \text{ kJ/kg} \\ u_2 &= h_2 - Z_2 RT_2 = (-4105.2) - (0.9739)(0.5182)(523.15) = -4369.2 \text{ kJ/kg} \end{aligned}$$

$$v_2 = Z_2 R \frac{T_2}{P_2} = (0.9739)(0.5182) \frac{523.15}{5000} = 0.05281 \text{ m}^3/\text{kg}$$

$$\Delta s_2 = Z_{s2} R = (0.1281)(0.5182 \text{ kJ/kg}\cdot\text{K}) = 0.06639 \text{ kJ/kg}\cdot\text{K}$$

$$s_2 = s_{2,\text{ideal}} - \Delta s_2 = 11.035 - 0.06639 = 10.968 \text{ kJ/kg}\cdot\text{K}$$

Then,

$$w_{\text{chart}} = P(v_2 - v_1) = (5000 \text{ kPa})(0.05281 - 0.03393) \text{ m}^3/\text{kg} = \mathbf{94.38 \text{ kJ/kg}}$$

$$q_{\text{chart}} = w_{\text{chart}} + (u_2 - u_1) = 94.38 + [(-4369.2) - (-4729.6)] = \mathbf{454.7 \text{ kJ/kg}}$$

$$\Delta s_{\text{chart}} = s_2 - s_1 = 10.968 - 9.946 = \mathbf{1.02 \text{ kJ/kg}}$$

The solution using EES built-in property data is as follows:

$$\left. \begin{array}{l} T_1 = 100^\circ\text{C} \\ P_1 = 5 \text{ MPa} \end{array} \right\} \begin{array}{l} v_1 = 0.03753 \text{ m}^3/\text{kg} \\ u_1 = -45.10 \text{ kJ/kg} \\ s_1 = -1.569 \text{ kJ/kg}\cdot\text{K} \end{array}$$

$$\left. \begin{array}{l} T_2 = 250^\circ\text{C} \\ P_2 = 5 \text{ MPa} \end{array} \right\} \begin{array}{l} v_2 = 0.05443 \text{ m}^3/\text{kg} \\ u_2 = 293.22 \text{ kJ/kg} \\ s_2 = -0.6204 \text{ kJ/kg}\cdot\text{K} \end{array}$$

$$w_{\text{EES}} = P(v_2 - v_1) = (5000 \text{ kPa})(0.05443 - 0.03753) \text{ m}^3/\text{kg} = \mathbf{84.47 \text{ kJ/kg}}$$

$$q_{\text{EES}} = w_{\text{EES}} + (u_2 - u_1) = 84.47 + [293.22 - (-45.10)] = \mathbf{422.8 \text{ kJ/kg}}$$

$$\Delta s_{\text{EES}} = s_2 - s_1 = -0.6204 - (-1.569) = \mathbf{0.948 \text{ kJ/kg}}$$

12-98E Methane is compressed steadily. The entropy change and the specific work required are to be determined using the departure charts and the property tables.

Properties The properties of methane are (Table A-1E)

$$M = 16.043 \text{ lbm/lbmol}, T_{\text{cr}} = 343.9 \text{ R}, P_{\text{cr}} = 673 \text{ psia}, c_p = 0.532 \text{ Btu/lbm} \cdot \text{R}, R = 0.1238 \text{ Btu/lbm} \cdot \text{R}$$

Analysis (a) Using empirical correlation for the c_p of methane as given in Table A-2Ec gives

$$\begin{aligned} \bar{h}_2 - \bar{h}_1 &= \int c_p dT = \int (a + bT + cT^2 + dT^3) dT \\ &= a(T_2 - T_1) + \frac{b}{2}(T_2^2 - T_1^2) + \frac{c}{3}(T_2^3 - T_1^3) + \frac{d}{4}(T_2^4 - T_1^4) \\ &= 4.750(1000) + \frac{0.6666 \times 10^{-2}}{2}(1560^2 - 560^2) + \frac{0.09352 \times 10^{-5}}{3}(1560^3 - 560^3) \\ &\quad + \frac{-0.4510 \times 10^{-9}}{4}(1560^4 - 560^4) \\ &= 12,288 \text{ Btu/lbmol} \cdot \text{R} \end{aligned}$$

The work input is equal to the enthalpy change. The enthalpy change per unit mass is

$$w_{\text{in}} = h_2 - h_1 = \frac{\bar{h}_2 - \bar{h}_1}{M} = \frac{12,288 \text{ Btu/lbmol}}{16.043 \text{ lbm/lbmol}} = \mathbf{765.9 \text{ Btu/lbm}}$$

Similarly, the entropy change is given by

$$\begin{aligned} (\bar{s}_2 - \bar{s}_1)_{\text{ideal}} &= \int_1^2 \frac{c_p}{T} dT - R_u \ln \frac{P_2}{P_1} = \int_1^2 \left(\frac{a}{T} + b + cT + dT^2 \right) dT - R_u \ln \frac{P_2}{P_1} \\ &= a \ln \frac{T_2}{T_1} + b(T_2 - T_1) + \frac{c}{2}(T_2^2 - T_1^2) + \frac{d}{3}(T_2^3 - T_1^3) - R_u \ln \frac{P_2}{P_1} \\ &= 4.750 \ln \frac{1560}{560} + 0.6666 \times 10^{-2} (1560 - 560) + \frac{0.09352 \times 10^{-5}}{2} (1560^2 - 560^2) \\ &\quad + \frac{-0.4510 \times 10^{-9}}{3} (1560^3 - 560^3) - (1.9858) \ln \frac{500}{50} \\ &= 7.407 \text{ Btu/lbmol} \cdot \text{R} \end{aligned}$$

The entropy change per unit mass is

$$(s_2 - s_1)_{\text{ideal}} = \frac{(\bar{s}_2 - \bar{s}_1)_{\text{ideal}}}{M} = \frac{7.407 \text{ Btu/lbmol} \cdot \text{R}}{16.043 \text{ lbm/lbmol}} = \mathbf{0.4617 \text{ Btu/lbm} \cdot \text{R}}$$

(b) The enthalpy and entropy departures of water vapor at the specified states are determined from the generalized charts to be (Figs. A-29, A-30 or from EES. We used EES.)

$$\left. \begin{aligned} T_{R1} &= \frac{T_1}{T_{\text{cr}}} = \frac{560}{343.9} = 1.63 \\ P_{R1} &= \frac{P_1}{P_{\text{cr}}} = \frac{50}{673} = 0.0743 \end{aligned} \right\} \longrightarrow Z_{h1} = 0.03313 \text{ and } Z_{s1} = 0.01617$$

and

$$\left. \begin{aligned} T_{R2} &= \frac{T_2}{T_{\text{cr}}} = \frac{1560}{343.9} = 4.54 \\ P_{R2} &= \frac{P_2}{P_{\text{cr}}} = \frac{500}{673} = 0.743 \end{aligned} \right\} \longrightarrow Z_{h2} = 0 \text{ and } Z_{s2} = 0.00695$$

The work input and entropy changes are

$$\begin{aligned} w_{\text{in}} = h_2 - h_1 &= (h_2 - h_1)_{\text{ideal}} - RT_{\text{cr}}(Z_{h2} - Z_{h1}) \\ &= 765.9 - (0.1238)(343.9)(0 - 0.03313) = \mathbf{767.4 \text{ Btu/lbm}} \end{aligned}$$

$$\begin{aligned} s_2 - s_1 &= (s_2 - s_1)_{\text{ideal}} - R(Z_{s2} - Z_{s1}) \\ &= 0.4617 - (0.1238)(0.00695 - 0.01617) = \mathbf{0.4628 \text{ Btu/lbm} \cdot \text{R}} \end{aligned}$$

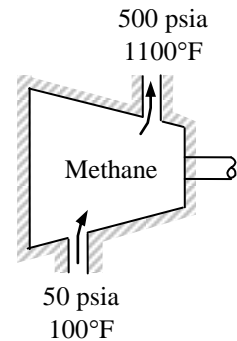

12-99E Methane is compressed in a steady-flow device. The second-law efficiency of the compression process is to be determined.

Analysis The reversible work input to the compressor is determined from

$$w_{\text{rev}} = h_2 - h_1 - T_0(s_2 - s_1) = 767.4 \text{ Btu/lbm} - (537 \text{ R})(0.4628 \text{ Btu/lbm} \cdot \text{R}) = 518.8 \text{ Btu/lbm}$$

The second-law efficiency of the compressor is

$$\eta_{\text{II}} = \frac{w_{\text{rev}}}{w_{\text{actual}}} = \frac{518.8}{767.4} = 0.676 = \mathbf{67.6\%}$$

Fundamentals of Engineering (FE) Exam Problems

12-100 A substance whose Joule-Thomson coefficient is negative is throttled to a lower pressure. During this process, (select the correct statement)

- (a) the temperature of the substance will increase.
- (b) the temperature of the substance will decrease.
- (c) the entropy of the substance will remain constant.
- (d) the entropy of the substance will decrease.
- (e) the enthalpy of the substance will decrease.

Answer (a) the temperature of the substance will increase.

12-101 Consider the liquid-vapor saturation curve of a pure substance on the P - T diagram. The magnitude of the slope of the tangent line to this curve at a temperature T (in Kelvin) is

- (a) proportional to the enthalpy of vaporization h_{fg} at that temperature,
- (b) proportional to the temperature T ,
- (c) proportional to the square of the temperature T ,
- (d) proportional to the volume change v_{fg} at that temperature,
- (e) inversely proportional to the entropy change s_{fg} at that temperature,

Answer (a) proportional to the enthalpy of vaporization h_{fg} at that temperature,

12-102 Based on the generalized charts, the error involved in the enthalpy of CO₂ at 300 K and 5 MPa if it is assumed to be an ideal gas is

- (a) 0 (b) 9% (c) 16% (d) 22% (e) 27%

Answer (e) 27%

Solution Solved by EES Software. Solutions can be verified by copying-and-pasting the following lines on a blank EES screen. (Similar problems and their solutions can be obtained easily by modifying numerical values).

```
T=300 "K"
P=5000 "kPa"
Pcr=P_CRIT(CarbonDioxide)
Tcr=T_CRIT(CarbonDioxide)
Tr=T/Tcr
Pr=P/Pcr
hR=ENTHDEP(Tr, Pr)
h_ideal=11351/Molarmass(CO2) "Table A-20 of the text"
h_chart=h_ideal-R*Tcr*hR
R=0.1889
Error=(h_chart-h_ideal)/h_chart*Convert(, %)
```

12-103 Based on data from the refrigerant-134a tables, the Joule-Thompson coefficient of refrigerant-134a at 0.8 MPa and 100°C is approximately

- (a) 0 (b) -5°C/MPa (c) 11°C/MPa (d) 8°C/MPa (e) 26°C/MPa

Answer (c) 11°C/MPa

Solution Solved by EES Software. Solutions can be verified by copying-and-pasting the following lines on a blank EES screen. (Similar problems and their solutions can be obtained easily by modifying numerical values).

```
T1=100 "C"
P1=800 "kPa"
h1=ENTHALPY(R134a,T=T1,P=P1)
Tlow=TEMPERATURE(R134a,h=h1,P=P1+100)
Thigh=TEMPERATURE(R134a,h=h1,P=P1-100)
JT=(Tlow-Thigh)/200
```

12-104 For a gas whose equation of state is $P(\nu - b) = RT$, the specific heat difference $c_p - c_\nu$ is equal to

- (a) R (b) $R - b$ (c) $R + b$ (d) 0 (e) $R(1 + \nu/b)$

Answer (a) R

Solution The general relation for the specific heat difference $c_p - c_\nu$ is

$$c_p - c_\nu = -T \left(\frac{\partial \nu}{\partial T} \right)_P^2 \left(\frac{\partial P}{\partial \nu} \right)_T$$

For the given gas, $P(\nu - b) = RT$. Then,

$$\nu = \frac{RT}{P} + b \longrightarrow \left(\frac{\partial \nu}{\partial T} \right)_P = \frac{R}{P}$$

$$P = \frac{RT}{\nu - b} \longrightarrow \left(\frac{\partial P}{\partial \nu} \right)_T = -\frac{RT}{(\nu - b)^2} = -\frac{P}{\nu - b}$$

Substituting,

$$c_p - c_\nu = -T \left(\frac{R}{P} \right)^2 \left(-\frac{P}{\nu - b} \right) = \frac{TR^2}{P(\nu - b)} = R$$

12-105 ... 12-107 Design and Essay Problems



Solutions Manual for
Thermodynamics: An Engineering Approach
8th Edition
Yunus A. Çengel, Michael A. Boles
McGraw-Hill, 2015

Chapter 13

GAS MIXTURES

PROPRIETARY AND CONFIDENTIAL

This Manual is the proprietary property of McGraw-Hill Education and protected by copyright and other state and federal laws. By opening and using this Manual the user agrees to the following restrictions, and if the recipient does not agree to these restrictions, the Manual should be promptly returned unopened to McGraw-Hill Education: **This Manual is being provided only to authorized professors and instructors for use in preparing for the classes using the affiliated textbook. No other use or distribution of this Manual is permitted. This Manual may not be sold and may not be distributed to or used by any student or other third party. No part of this Manual may be reproduced, displayed or distributed in any form or by any means, electronic or otherwise, without the prior written permission of McGraw-Hill Education.**

Composition of Gas Mixtures

13-1C The mass fractions will be identical, but the mole fractions will not.

13-2C Yes.

13-3C Yes, because both CO_2 and N_2O has the same molar mass, $M = 44 \text{ kg/kmol}$.

13-4C No. We can do this only when each gas has the same mole fraction.

13-5C It is the average or the equivalent molar mass of the gas mixture. No.

13-6 From the definition of mass fraction,

$$\text{mf}_i = \frac{m_i}{m_m} = \frac{N_i M_i}{N_m M_m} = y_i \left(\frac{M_i}{M_m} \right)$$

13-7 A mixture consists of two gases. Relations for mole fractions when mass fractions are known are to be obtained .

Analysis The mass fractions of A and B are expressed as

$$\text{mf}_A = \frac{m_A}{m_m} = \frac{N_A M_A}{N_m M_m} = y_A \frac{M_A}{M_m} \quad \text{and} \quad \text{mf}_B = y_B \frac{M_B}{M_m}$$

Where m is mass, M is the molar mass, N is the number of moles, and y is the mole fraction. The apparent molar mass of the mixture is

$$M_m = \frac{m_m}{N_m} = \frac{N_A M_A + N_B M_B}{N_m} = y_A M_A + y_B M_B$$

Combining the two equation above and noting that $y_A + y_B = 1$ gives the following convenient relations for converting mass fractions to mole fractions,

$$y_A = \frac{M_B}{M_A (1/\text{mf}_A - 1) + M_B} \quad \text{and} \quad y_B = 1 - y_A$$

which are the desired relations.

13-8 The molar fractions of the constituents of moist air are given. The mass fractions of the constituents are to be determined.

Assumptions The small amounts of gases in air are ignored, and dry air is assumed to consist of N_2 and O_2 only.

Properties The molar masses of N_2 , O_2 , and H_2O are 28.0, 32.0, and 18.0 kg/kmol, respectively (Table A-1).

Analysis The molar mass of moist air is

$$M = \sum y_i M_i = 0.78 \times 28.0 + 0.20 \times 32.0 + 0.02 \times 18 = 28.6 \text{ kg/kmol}$$

Then the mass fractions of constituent gases are determined to be

$$N_2: \quad mf_{N_2} = y_{N_2} \frac{M_{N_2}}{M} = (0.78) \frac{28.0}{28.6} = \mathbf{0.764}$$

$$O_2: \quad mf_{O_2} = y_{O_2} \frac{M_{O_2}}{M} = (0.20) \frac{32.0}{28.6} = \mathbf{0.224}$$

$$H_2O: \quad mf_{H_2O} = y_{H_2O} \frac{M_{H_2O}}{M} = (0.02) \frac{18.0}{28.6} = \mathbf{0.013}$$

Therefore, the mass fractions of N_2 , O_2 , and H_2O in the air are 76.4%, 22.4%, and 1.3%, respectively.

Moist air
78% N_2
20% O_2
2% H_2O
(Mole fractions)

13-9 The molar fractions of the constituents of a gas mixture are given. The gravimetric analysis of the mixture, its molar mass, and gas constant are to be determined.

Properties The molar masses of N_2 , and CO_2 are 28.0 and 44.0 kg/kmol, respectively (Table A-1)

Analysis Consider 100 kmol of mixture. Then the mass of each component and the total mass are

$$N_{N_2} = 60 \text{ kmol} \longrightarrow m_{N_2} = N_{N_2} M_{N_2} = (60 \text{ kmol})(28 \text{ kg/kmol}) = 1680 \text{ kg}$$

$$N_{CO_2} = 40 \text{ kmol} \longrightarrow m_{CO_2} = N_{CO_2} M_{CO_2} = (40 \text{ kmol})(44 \text{ kg/kmol}) = 1760 \text{ kg}$$

$$m_m = m_{N_2} + m_{CO_2} = 1680 \text{ kg} + 1760 \text{ kg} = 3440 \text{ kg}$$

Then the mass fraction of each component (gravimetric analysis) becomes

$$mf_{N_2} = \frac{m_{N_2}}{m_m} = \frac{1680 \text{ kg}}{3440 \text{ kg}} = 0.488 \text{ or } \mathbf{48.8\%}$$

$$mf_{CO_2} = \frac{m_{CO_2}}{m_m} = \frac{1760 \text{ kg}}{3440 \text{ kg}} = 0.512 \text{ or } \mathbf{51.2\%}$$

mole
60% N_2
40% CO_2

The molar mass and the gas constant of the mixture are determined from their definitions,

$$M_m = \frac{m_m}{N_m} = \frac{3,440 \text{ kg}}{100 \text{ kmol}} = \mathbf{34.40 \text{ kg/kmol}}$$

and

$$R_m = \frac{R_u}{M_m} = \frac{8.314 \text{ kJ/kmol} \cdot \text{K}}{34.4 \text{ kg/kmol}} = \mathbf{0.242 \text{ kJ/kg} \cdot \text{K}}$$

13-10 The molar fractions of the constituents of a gas mixture are given. The gravimetric analysis of the mixture, its molar mass, and gas constant are to be determined.

Properties The molar masses of O₂ and CO₂ are 32.0 and 44.0 kg/kmol, respectively (Table A-1)

Analysis Consider 100 kmol of mixture. Then the mass of each component and the total mass are

$$N_{\text{O}_2} = 60 \text{ kmol} \longrightarrow m_{\text{O}_2} = N_{\text{O}_2} M_{\text{O}_2} = (60 \text{ kmol})(32 \text{ kg/kmol}) = 1920 \text{ kg}$$

$$N_{\text{CO}_2} = 40 \text{ kmol} \longrightarrow m_{\text{CO}_2} = N_{\text{CO}_2} M_{\text{CO}_2} = (40 \text{ kmol})(44 \text{ kg/kmol}) = 1760 \text{ kg}$$

$$m_m = m_{\text{O}_2} + m_{\text{CO}_2} = 1920 \text{ kg} + 1760 \text{ kg} = 3680 \text{ kg}$$

Then the mass fraction of each component (gravimetric analysis) becomes

$$\text{mf}_{\text{O}_2} = \frac{m_{\text{O}_2}}{m_m} = \frac{1920 \text{ kg}}{3680 \text{ kg}} = 0.522 \text{ or } \mathbf{52.2\%}$$

$$\text{mf}_{\text{CO}_2} = \frac{m_{\text{CO}_2}}{m_m} = \frac{1760 \text{ kg}}{3680 \text{ kg}} = 0.478 \text{ or } \mathbf{47.8\%}$$

mole
60% O ₂
40% CO ₂

The molar mass and the gas constant of the mixture are determined from their definitions,

$$M_m = \frac{m_m}{N_m} = \frac{3680 \text{ kg}}{100 \text{ kmol}} = \mathbf{36.80 \text{ kg/kmol}}$$

and

$$R_m = \frac{R_u}{M_m} = \frac{8.314 \text{ kJ/kmol} \cdot \text{K}}{36.8 \text{ kg/kmol}} = \mathbf{0.226 \text{ kJ/kg} \cdot \text{K}}$$

13-11 The masses of the constituents of a gas mixture are given. The mass fractions, the mole fractions, the average molar mass, and gas constant are to be determined.

Properties The molar masses of O₂, N₂, and CO₂ are 32.0, 28.0 and 44.0 kg/kmol, respectively (Table A-1)

Analysis (a) The total mass of the mixture is

$$m_m = m_{\text{O}_2} + m_{\text{N}_2} + m_{\text{CO}_2} = 2 \text{ kg} + 5 \text{ kg} + 7 \text{ kg} = 14 \text{ kg}$$

Then the mass fraction of each component becomes

$$\text{mf}_{\text{O}_2} = \frac{m_{\text{O}_2}}{m_m} = \frac{2 \text{ kg}}{14 \text{ kg}} = \mathbf{0.1429}$$

$$\text{mf}_{\text{N}_2} = \frac{m_{\text{N}_2}}{m_m} = \frac{5 \text{ kg}}{14 \text{ kg}} = \mathbf{0.3571}$$

$$\text{mf}_{\text{CO}_2} = \frac{m_{\text{CO}_2}}{m_m} = \frac{7 \text{ kg}}{14 \text{ kg}} = \mathbf{0.5}$$

<p>2 kg O₂ 5 kg N₂ 7 kg CO₂</p>
--

(b) To find the mole fractions, we need to determine the mole numbers of each component first,

$$N_{\text{O}_2} = \frac{m_{\text{O}_2}}{M_{\text{O}_2}} = \frac{2 \text{ kg}}{32 \text{ kg/kmol}} = 0.0625 \text{ kmol}$$

$$N_{\text{N}_2} = \frac{m_{\text{N}_2}}{M_{\text{N}_2}} = \frac{5 \text{ kg}}{28 \text{ kg/kmol}} = 0.1786 \text{ kmol}$$

$$N_{\text{CO}_2} = \frac{m_{\text{CO}_2}}{M_{\text{CO}_2}} = \frac{7 \text{ kg}}{44 \text{ kg/kmol}} = 0.1591 \text{ kmol}$$

Thus,

$$N_m = N_{\text{O}_2} + N_{\text{N}_2} + N_{\text{CO}_2} = 0.0625 \text{ kmol} + 0.1786 \text{ kmol} + 0.1591 \text{ kmol} = 0.4002 \text{ kmol}$$

and

$$y_{\text{O}_2} = \frac{N_{\text{O}_2}}{N_m} = \frac{0.0625 \text{ kmol}}{0.4002 \text{ kmol}} = \mathbf{0.1562}$$

$$y_{\text{N}_2} = \frac{N_{\text{N}_2}}{N_m} = \frac{0.1786 \text{ kmol}}{0.4002 \text{ kmol}} = \mathbf{0.4462}$$

$$y_{\text{CO}_2} = \frac{N_{\text{CO}_2}}{N_m} = \frac{0.1591 \text{ kmol}}{0.4002 \text{ kmol}} = \mathbf{0.3976}$$

(c) The average molar mass and gas constant of the mixture are determined from their definitions:

$$M_m = \frac{m_m}{N_m} = \frac{14 \text{ kg}}{0.4002 \text{ kmol}} = \mathbf{34.99 \text{ kg/kmol}}$$

and

$$R_m = \frac{R_u}{M_m} = \frac{8.314 \text{ kJ/kmol} \cdot \text{K}}{34.99 \text{ kg/kmol}} = \mathbf{0.2376 \text{ kJ/kg} \cdot \text{K}}$$

13-12 The mass fractions of the constituents of a gas mixture are given. The mole fractions of the gas and gas constant are to be determined.

Properties The molar masses of CH₄, and CO₂ are 16.0 and 44.0 kg/kmol, respectively (Table A-1)

Analysis For convenience, consider 100 kg of the mixture. Then the number of moles of each component and the total number of moles are

$$m_{\text{CH}_4} = 75 \text{ kg} \longrightarrow N_{\text{CH}_4} = \frac{m_{\text{CH}_4}}{M_{\text{CH}_4}} = \frac{75 \text{ kg}}{16 \text{ kg/kmol}} = 4.688 \text{ kmol}$$

$$m_{\text{CO}_2} = 25 \text{ kg} \longrightarrow N_{\text{CO}_2} = \frac{m_{\text{CO}_2}}{M_{\text{CO}_2}} = \frac{25 \text{ kg}}{44 \text{ kg/kmol}} = 0.568 \text{ kmol}$$

$$N_m = N_{\text{CH}_4} + N_{\text{CO}_2} = 4.688 \text{ kmol} + 0.568 \text{ kmol} = 5.256 \text{ kmol}$$

mass
75% CH ₄
25% CO ₂

Then the mole fraction of each component becomes

$$y_{\text{CH}_4} = \frac{N_{\text{CH}_4}}{N_m} = \frac{4.688 \text{ kmol}}{5.256 \text{ kmol}} = 0.892 \text{ or } \mathbf{89.2\%}$$

$$y_{\text{CO}_2} = \frac{N_{\text{CO}_2}}{N_m} = \frac{0.568 \text{ kmol}}{5.256 \text{ kmol}} = 0.108 \text{ or } \mathbf{10.8\%}$$

The molar mass and the gas constant of the mixture are determined from their definitions,

$$M_m = \frac{m_m}{N_m} = \frac{100 \text{ kg}}{5.256 \text{ kmol}} = 19.03 \text{ kg/kmol}$$

and

$$R_m = \frac{R_u}{M_m} = \frac{8.314 \text{ kJ/kmol} \cdot \text{K}}{19.03 \text{ kg/kmol}} = \mathbf{0.437 \text{ kJ/kg} \cdot \text{K}}$$

13-13 The mole numbers of the constituents of a gas mixture are given. The mass of each gas and the apparent gas constant are to be determined.

Properties The molar masses of H₂, and N₂ are 2.0 and 28.0 kg/kmol, respectively (Table A-1)

Analysis The mass of each component is determined from

$$N_{\text{H}_2} = 5 \text{ kmol} \longrightarrow m_{\text{H}_2} = N_{\text{H}_2} M_{\text{H}_2} = (5 \text{ kmol})(2.0 \text{ kg/kmol}) = \mathbf{10 \text{ kg}}$$

$$N_{\text{N}_2} = 2 \text{ kmol} \longrightarrow m_{\text{N}_2} = N_{\text{N}_2} M_{\text{N}_2} = (2 \text{ kmol})(28 \text{ kg/kmol}) = \mathbf{56 \text{ kg}}$$

The total mass and the total number of moles are

$$m_m = m_{\text{H}_2} + m_{\text{N}_2} = 10 \text{ kg} + 56 \text{ kg} = 66 \text{ kg}$$

$$N_m = N_{\text{H}_2} + N_{\text{N}_2} = 5 \text{ kmol} + 2 \text{ kmol} = 7 \text{ kmol}$$

6 kmol H ₂
2 kmol N ₂

The molar mass and the gas constant of the mixture are determined from their definitions,

$$M_m = \frac{m_m}{N_m} = \frac{66 \text{ kg}}{7 \text{ kmol}} = 9.43 \text{ kg/kmol}$$

and

$$R_m = \frac{R_u}{M_m} = \frac{8.314 \text{ kJ/kmol} \cdot \text{K}}{9.43 \text{ kg/kmol}} = \mathbf{0.881 \text{ kJ/kg} \cdot \text{K}}$$

P-v-T Behavior of Gas Mixtures

13-14C Normally yes. Air, for example, behaves as an ideal gas in the range of temperatures and pressures at which oxygen and nitrogen behave as ideal gases.

13-15C The pressure of a gas mixture is equal to the sum of the pressures each gas would exert if existed alone at the mixture temperature and volume. This law holds exactly for ideal gas mixtures, but only approximately for real gas mixtures.

13-16C The volume of a gas mixture is equal to the sum of the volumes each gas would occupy if existed alone at the mixture temperature and pressure. This law holds exactly for ideal gas mixtures, but only approximately for real gas mixtures.

13-17C The P - v - T behavior of a component in an ideal gas mixture is expressed by the ideal gas equation of state using the properties of the individual component instead of the mixture, $P_i v_i = R_i T_i$. The P - v - T behavior of a component in a real gas mixture is expressed by more complex equations of state, or by $P_i v_i = Z_i R_i T_i$, where Z_i is the compressibility factor.

13-18C Component pressure is the pressure a component would exert if existed alone at the mixture temperature and volume. Partial pressure is the quantity $y_i P_m$, where y_i is the mole fraction of component i . These two are identical for ideal gases.

13-19C Component volume is the volume a component would occupy if existed alone at the mixture temperature and pressure. Partial volume is the quantity $y_i V_m$, where y_i is the mole fraction of component i . These two are identical for ideal gases.

13-20C The one with the highest mole number.

13-21C The partial pressures will decrease but the pressure fractions will remain the same.

13-22C The partial pressures will increase but the pressure fractions will remain the same.

13-23C No. The correct expression is “the volume of a gas mixture is equal to the sum of the volumes each gas would occupy if existed alone at the mixture temperature and pressure.”

13-24C No. The correct expression is “the temperature of a gas mixture is equal to the temperature of the individual gas components.”

13-25C Yes, it is correct.

13-26 The partial pressure of R-134a in atmospheric air to form a 100-ppm contaminant is to be determined.

Analysis Noting that volume fractions and mole fractions are equal, the molar fraction of R-134a in air is

$$y_{R134a} = \frac{100}{10^6} = 0.0001$$

The partial pressure of R-134a in air is then

$$P_{R134a} = y_{R134a} P_m = (0.0001)(100 \text{ kPa}) = \mathbf{0.01 \text{ kPa}}$$

13-27 The volume fractions of components of a gas mixture are given. The mass fractions and apparent molecular weight of the mixture are to be determined.

Properties The molar masses of H₂, He, and N₂ are 2.0, 4.0, and 28.0 kg/kmol, respectively (Table A-1).

Analysis We consider 100 kmol of this mixture. Noting that volume fractions are equal to the mole fractions, mass of each component are

$$\begin{aligned} m_{H_2} &= N_{H_2} M_{H_2} = (30 \text{ kmol})(2 \text{ kg/kmol}) = 60 \text{ kg} \\ m_{He} &= N_{He} M_{He} = (40 \text{ kmol})(4 \text{ kg/kmol}) = 160 \text{ kg} \\ m_{N_2} &= N_{N_2} M_{N_2} = (30 \text{ kmol})(28 \text{ kg/kmol}) = 840 \text{ kg} \end{aligned}$$

The total mass is

$$m_m = m_{H_2} + m_{He} + m_{N_2} = 60 + 160 + 840 = 1060 \text{ kg}$$

Then the mass fractions are

$$\begin{aligned} \text{mf}_{H_2} &= \frac{m_{H_2}}{m_m} = \frac{60 \text{ kg}}{1060 \text{ kg}} = \mathbf{0.05660} \\ \text{mf}_{He} &= \frac{m_{He}}{m_m} = \frac{160 \text{ kg}}{1060 \text{ kg}} = \mathbf{0.1509} \\ \text{mf}_{N_2} &= \frac{m_{N_2}}{m_m} = \frac{840 \text{ kg}}{1060 \text{ kg}} = \mathbf{0.7925} \end{aligned}$$

<p>30% H₂ 40% He 30% N₂ (by volume)</p>

The apparent molecular weight of the mixture is

$$M_m = \frac{m_m}{N_m} = \frac{1060 \text{ kg}}{100 \text{ kmol}} = \mathbf{10.60 \text{ kg/kmol}}$$

13-28E The masses of the constituents of a gas mixture at a specified pressure and temperature are given. The partial pressure of each gas and the apparent molar mass of the gas mixture are to be determined.

Assumptions Under specified conditions both CO_2 and CH_4 can be treated as ideal gases, and the mixture as an ideal gas mixture.

Properties The molar masses of CO_2 and CH_4 are 44.0 and 16.0 lbm/lbmol, respectively (Table A-1E)

Analysis The mole numbers of gases are

$$m_{\text{CO}_2} = 1 \text{ lbm} \longrightarrow N_{\text{CO}_2} = \frac{m_{\text{CO}_2}}{M_{\text{CO}_2}} = \frac{1 \text{ lbm}}{44 \text{ lbm/lbmol}} = 0.0227 \text{ lbmol}$$

$$m_{\text{CH}_4} = 3 \text{ lbm} \longrightarrow N_{\text{CH}_4} = \frac{m_{\text{CH}_4}}{M_{\text{CH}_4}} = \frac{3 \text{ lbm}}{16 \text{ lbm/lbmol}} = 0.1875 \text{ lbmol}$$

$$N_m = N_{\text{CO}_2} + N_{\text{CH}_4} = 0.0227 \text{ lbmol} + 0.1875 \text{ lbmol} = 0.2102 \text{ lbmol}$$

$$y_{\text{CO}_2} = \frac{N_{\text{CO}_2}}{N_m} = \frac{0.0227 \text{ lbmol}}{0.2102 \text{ lbmol}} = 0.108$$

$$y_{\text{CH}_4} = \frac{N_{\text{CH}_4}}{N_m} = \frac{0.1875 \text{ lbmol}}{0.2102 \text{ lbmol}} = 0.892$$

1 lbm CO_2 3 lbm CH_4 600 R 20 psia
--

Then the partial pressures become

$$P_{\text{CO}_2} = y_{\text{CO}_2} P_m = (0.108)(20 \text{ psia}) = \mathbf{2.16 \text{ psia}}$$

$$P_{\text{CH}_4} = y_{\text{CH}_4} P_m = (0.892)(20 \text{ psia}) = \mathbf{17.84 \text{ psia}}$$

The apparent molar mass of the mixture is

$$M_m = \frac{m_m}{N_m} = \frac{4 \text{ lbm}}{0.2102 \text{ lbmol}} = \mathbf{19.03 \text{ lbm/lbmol}}$$

13-29 The volumetric fractions of the constituents of a gas mixture at a specified pressure and temperature are given. The mass fraction and partial pressure of each gas are to be determined.

Assumptions Under specified conditions all N_2 , O_2 and CO_2 can be treated as ideal gases, and the mixture as an ideal gas mixture.

Properties The molar masses of N_2 , O_2 and CO_2 are 28.0, 32.0, and 44.0 kg/kmol, respectively (Table A-1)

Analysis For convenience, consider 100 kmol of mixture. Then the mass of each component and the total mass are

$$N_{N_2} = 65 \text{ kmol} \longrightarrow m_{N_2} = N_{N_2} M_{N_2} = (65 \text{ kmol})(28 \text{ kg/kmol}) = 1820 \text{ kg}$$

$$N_{O_2} = 20 \text{ kmol} \longrightarrow m_{O_2} = N_{O_2} M_{O_2} = (20 \text{ kmol})(32 \text{ kg/kmol}) = 640 \text{ kg}$$

$$N_{CO_2} = 15 \text{ kmol} \longrightarrow m_{CO_2} = N_{CO_2} M_{CO_2} = (15 \text{ kmol})(44 \text{ kg/kmol}) = 660 \text{ kg}$$

$$m_m = m_{N_2} + m_{O_2} + m_{CO_2} = 1820 \text{ kg} + 640 \text{ kg} + 660 \text{ kg} = 3120 \text{ kg}$$

65% N_2
20% O_2
15% CO_2

350 K
300 kPa

Then the mass fraction of each component (gravimetric analysis) becomes

$$mf_{N_2} = \frac{m_{N_2}}{m_m} = \frac{1820 \text{ kg}}{3120 \text{ kg}} = 0.583 \text{ or } \mathbf{58.3\%}$$

$$mf_{O_2} = \frac{m_{O_2}}{m_m} = \frac{640 \text{ kg}}{3120 \text{ kg}} = 0.205 \text{ or } \mathbf{20.5\%}$$

$$mf_{CO_2} = \frac{m_{CO_2}}{m_m} = \frac{660 \text{ kg}}{3120 \text{ kg}} = 0.212 \text{ or } \mathbf{21.2\%}$$

For ideal gases, the partial pressure is proportional to the mole fraction, and is determined from

$$P_{N_2} = y_{N_2} P_m = (0.65)(300 \text{ kPa}) = \mathbf{195 \text{ kPa}}$$

$$P_{O_2} = y_{O_2} P_m = (0.20)(300 \text{ kPa}) = \mathbf{60 \text{ kPa}}$$

$$P_{CO_2} = y_{CO_2} P_m = (0.15)(300 \text{ kPa}) = \mathbf{45 \text{ kPa}}$$

13-30 The partial pressures of a gas mixture are given. The mole fractions, the mass fractions, the mixture molar mass, the apparent gas constant, the constant-volume specific heat, and the specific heat ratio are to be determined.

Properties The molar masses of CO₂, O₂ and N₂ are 44.0, 32.0, and 28.0 kg/kmol, respectively (Table A-1). The constant-volume specific heats of these gases at 300 K are 0.657, 0.658, and 0.743 kJ/kg·K, respectively (Table A-2a).

Analysis The total pressure is

$$P_{\text{total}} = P_{\text{CO}_2} + P_{\text{O}_2} + P_{\text{N}_2} = 20 + 30 + 50 = 100 \text{ kPa}$$

The volume fractions are equal to the pressure fractions. Then,

$$y_{\text{CO}_2} = \frac{P_{\text{CO}_2}}{P_{\text{total}}} = \frac{20}{100} = \mathbf{0.20}$$

$$y_{\text{O}_2} = \frac{P_{\text{O}_2}}{P_{\text{total}}} = \frac{30}{100} = \mathbf{0.30}$$

$$y_{\text{N}_2} = \frac{P_{\text{N}_2}}{P_{\text{total}}} = \frac{50}{100} = \mathbf{0.50}$$

Partial pressures
CO₂, 20 kPa
O₂, 30 kPa
N₂, 50 kPa

We consider 100 kmol of this mixture. Then the mass of each component are

$$m_{\text{CO}_2} = N_{\text{CO}_2} M_{\text{CO}_2} = (20 \text{ kmol})(44 \text{ kg/kmol}) = 880 \text{ kg}$$

$$m_{\text{O}_2} = N_{\text{O}_2} M_{\text{O}_2} = (30 \text{ kmol})(32 \text{ kg/kmol}) = 960 \text{ kg}$$

$$m_{\text{N}_2} = N_{\text{N}_2} M_{\text{N}_2} = (50 \text{ kmol})(28 \text{ kg/kmol}) = 1400 \text{ kg}$$

The total mass is

$$m_m = m_{\text{N}_2} + m_{\text{O}_2} + m_{\text{Ar}} = 880 + 960 + 1400 = 3240 \text{ kg}$$

Then the mass fractions are

$$\text{mf}_{\text{CO}_2} = \frac{m_{\text{CO}_2}}{m_m} = \frac{880 \text{ kg}}{3240 \text{ kg}} = \mathbf{0.2716}$$

$$\text{mf}_{\text{O}_2} = \frac{m_{\text{O}_2}}{m_m} = \frac{960 \text{ kg}}{3240 \text{ kg}} = \mathbf{0.2963}$$

$$\text{mf}_{\text{N}_2} = \frac{m_{\text{N}_2}}{m_m} = \frac{1400 \text{ kg}}{3240 \text{ kg}} = \mathbf{0.4321}$$

The apparent molecular weight of the mixture is

$$M_m = \frac{m_m}{N_m} = \frac{3240 \text{ kg}}{100 \text{ kmol}} = \mathbf{32.40 \text{ kg/kmol}}$$

The constant-volume specific heat of the mixture is determined from

$$\begin{aligned} c_v &= \text{mf}_{\text{CO}_2} c_{v,\text{CO}_2} + \text{mf}_{\text{O}_2} c_{v,\text{O}_2} + \text{mf}_{\text{N}_2} c_{v,\text{N}_2} \\ &= 0.2716 \times 0.657 + 0.2963 \times 0.658 + 0.4321 \times 0.743 \\ &= \mathbf{0.6945 \text{ kJ/kg} \cdot \text{K}} \end{aligned}$$

The apparent gas constant of the mixture is

$$R = \frac{R_u}{M_m} = \frac{8.314 \text{ kJ/kmol} \cdot \text{K}}{32.40 \text{ kg/kmol}} = \mathbf{0.2566 \text{ kJ/kg} \cdot \text{K}}$$

The constant-pressure specific heat of the mixture and the specific heat ratio are

$$c_p = c_v + R = 0.6945 + 0.2566 = \mathbf{0.9511 \text{ kJ/kg} \cdot \text{K}}$$

$$k = \frac{c_p}{c_v} = \frac{0.9511 \text{ kJ/kg} \cdot \text{K}}{0.6945 \text{ kJ/kg} \cdot \text{K}} = \mathbf{1.370}$$

13-31 An additional 5% of oxygen is mixed with standard atmospheric air. The molecular weight of this mixture is to be determined.

Properties The molar masses of N_2 and O_2 are 28.0 and 32.0 kg/kmol, respectively (Table A-1).

Analysis Standard air is taken as 79% nitrogen and 21% oxygen by mole. That is,

$$y_{O_2} = 0.21$$

$$y_{N_2} = 0.79$$

Adding another 0.05 moles of O_2 to 1 kmol of standard air gives

$$y_{O_2} = \frac{0.26}{1.05} = 0.2476$$

$$y_{N_2} = \frac{0.79}{1.05} = 0.7524$$

Then,

$$M_m = y_{O_2}M_{O_2} + y_{N_2}M_{N_2} = 0.2476 \times 32 + 0.7524 \times 28 = \mathbf{28.99 \text{ kg/kmol}}$$

13-32 The masses, temperatures, and pressures of two gases contained in two tanks connected to each other are given. The valve connecting the tanks is opened and the final temperature is measured. The volume of each tank and the final pressure are to be determined.

Assumptions Under specified conditions both N_2 and O_2 can be treated as ideal gases, and the mixture as an ideal gas mixture

Properties The molar masses of N_2 and O_2 are 28.0 and 32.0 kg/kmol, respectively. The gas constants of N_2 and O_2 are 0.2968 and 0.2598 kPa·m³/kg·K, respectively (Table A-1).

Analysis The volumes of the tanks are

$$V_{N_2} = \left(\frac{mRT}{P} \right)_{N_2} = \frac{(2 \text{ kg})(0.2968 \text{ kPa} \cdot \text{m}^3/\text{kg} \cdot \text{K})(298 \text{ K})}{550 \text{ kPa}} = \mathbf{0.322 \text{ m}^3}$$

$$V_{O_2} = \left(\frac{mRT}{P} \right)_{O_2} = \frac{(4 \text{ kg})(0.2598 \text{ kPa} \cdot \text{m}^3/\text{kg} \cdot \text{K})(298 \text{ K})}{150 \text{ kPa}} = \mathbf{2.065 \text{ m}^3}$$

$$V_{\text{total}} = V_{N_2} + V_{O_2} = 0.322 \text{ m}^3 + 2.065 \text{ m}^3 = 2.386 \text{ m}^3$$

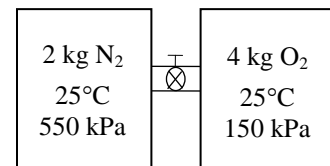

Also,

$$N_{N_2} = \frac{m_{N_2}}{M_{N_2}} = \frac{2 \text{ kg}}{28 \text{ kg/kmol}} = 0.07143 \text{ kmol}$$

$$N_{O_2} = \frac{m_{O_2}}{M_{O_2}} = \frac{4 \text{ kg}}{32 \text{ kg/kmol}} = 0.125 \text{ kmol}$$

$$N_m = N_{N_2} + N_{O_2} = 0.07143 \text{ kmol} + 0.125 \text{ kmol} = 0.1964 \text{ kmol}$$

Thus,

$$P_m = \left(\frac{NR_u T}{V} \right)_m = \frac{(0.1964 \text{ kmol})(8.314 \text{ kPa} \cdot \text{m}^3/\text{kmol} \cdot \text{K})(298 \text{ K})}{2.386 \text{ m}^3} = \mathbf{204 \text{ kPa}}$$

13-33 The masses of components of a gas mixture are given. The apparent molecular weight of this mixture, the volume it occupies, the partial volume of the oxygen, and the partial pressure of the helium are to be determined.

Properties The molar masses of O₂, CO₂, and He are 32.0, 44.0, and 4.0 kg/kmol, respectively (Table A-1).

Analysis The total mass of the mixture is

$$m_m = m_{\text{O}_2} + m_{\text{CO}_2} + m_{\text{He}} = 0.4 + 0.7 + 0.2 = 1.3 \text{ kg}$$

The mole numbers of each component are

$$N_{\text{O}_2} = \frac{m_{\text{O}_2}}{M_{\text{O}_2}} = \frac{0.4 \text{ kg}}{32 \text{ kg/kmol}} = 0.01250 \text{ kmol}$$

$$N_{\text{CO}_2} = \frac{m_{\text{CO}_2}}{M_{\text{CO}_2}} = \frac{0.7 \text{ kg}}{44 \text{ kg/kmol}} = 0.01591 \text{ kmol}$$

$$N_{\text{He}} = \frac{m_{\text{He}}}{M_{\text{He}}} = \frac{0.2 \text{ kg}}{4 \text{ kg/kmol}} = 0.05 \text{ kmol}$$

0.4 kg O ₂ 0.7 kg CO ₂ 0.2 kg He
--

The mole number of the mixture is

$$N_m = N_{\text{O}_2} + N_{\text{CO}_2} + N_{\text{He}} = 0.01250 + 0.01591 + 0.05 = 0.07841 \text{ kmol}$$

Then the apparent molecular weight of the mixture becomes

$$M_m = \frac{m_m}{N_m} = \frac{1.3 \text{ kg}}{0.07841 \text{ kmol}} = \mathbf{16.58 \text{ kg/kmol}}$$

The volume of this ideal gas mixture is

$$V_m = \frac{N_m R_u T}{P} = \frac{(0.07841 \text{ kmol})(8.314 \text{ kPa} \cdot \text{m}^3/\text{kmol} \cdot \text{K})(300 \text{ K})}{100 \text{ kPa}} = \mathbf{1.956 \text{ m}^3}$$

The partial volume of oxygen in the mixture is

$$V_{\text{O}_2} = y_{\text{O}_2} V_m = \frac{N_{\text{O}_2}}{N_m} V_m = \frac{0.01250 \text{ kmol}}{0.07841 \text{ kmol}} (1.956 \text{ m}^3) = \mathbf{0.3118 \text{ m}^3}$$

The partial pressure of helium in the mixture is

$$P_{\text{He}} = y_{\text{He}} P_m = \frac{N_{\text{He}}}{N_m} P_m = \frac{0.05 \text{ kmol}}{0.07841 \text{ kmol}} (100 \text{ kPa}) = \mathbf{63.77 \text{ kPa}}$$

13-34 The mass fractions of components of a gas mixture are given. The volume occupied by 100 kg of this mixture is to be determined.

Properties The molar masses of CH_4 , C_3H_8 , and C_4H_{10} are 16.0, 44.0, and 58.0 kg/kmol, respectively (Table A-1).

Analysis The mole numbers of each component are

$$N_{\text{CH}_4} = \frac{m_{\text{CH}_4}}{M_{\text{CH}_4}} = \frac{60 \text{ kg}}{16 \text{ kg/kmol}} = 3.75 \text{ kmol}$$

$$N_{\text{C}_3\text{H}_8} = \frac{m_{\text{C}_3\text{H}_8}}{M_{\text{C}_3\text{H}_8}} = \frac{25 \text{ kg}}{44 \text{ kg/kmol}} = 0.5682 \text{ kmol}$$

$$N_{\text{C}_4\text{H}_{10}} = \frac{m_{\text{C}_4\text{H}_{10}}}{M_{\text{C}_4\text{H}_{10}}} = \frac{15 \text{ kg}}{58 \text{ kg/kmol}} = 0.2586 \text{ kmol}$$

60% CH_4 25% C_3H_8 15% C_4H_{10} (by mass)

The mole number of the mixture is

$$N_m = N_{\text{CH}_4} + N_{\text{C}_3\text{H}_8} + N_{\text{C}_4\text{H}_{10}} = 3.75 + 0.5682 + 0.2586 = 4.5768 \text{ kmol}$$

The apparent molecular weight of the mixture is

$$M_m = \frac{m_m}{N_m} = \frac{100 \text{ kg}}{4.5768 \text{ kmol}} = 21.85 \text{ kg/kmol}$$

Then the volume of this ideal gas mixture is

$$V_m = \frac{N_m R_u T}{P} = \frac{(4.5768 \text{ kmol})(8.314 \text{ kPa} \cdot \text{m}^3/\text{kmol} \cdot \text{K})(310 \text{ K})}{3000 \text{ kPa}} = \mathbf{3.93 \text{ m}^3}$$

13-35 A tank contains a mixture of two gases of known masses at a specified pressure and temperature. The volume of the tank is to be determined.

Assumptions Under specified conditions both O_2 and CO_2 can be treated as ideal gases, and the mixture as an ideal gas mixture.

Analysis The total number of moles is

$$N_m = N_{\text{O}_2} + N_{\text{CO}_2} = 8 \text{ kmol} + 10 \text{ kmol} = 18 \text{ kmol}$$

Then

$$V_m = \frac{N_m R_u T_m}{P_m} = \frac{(18 \text{ kmol})(8.314 \text{ kPa} \cdot \text{m}^3/\text{kmol} \cdot \text{K})(290 \text{ K})}{150 \text{ kPa}} = \mathbf{289.3 \text{ m}^3}$$

8 kmol O_2 10 kmol CO_2
--

290 K 150 kPa

13-36 A tank contains a mixture of two gases of known masses at a specified pressure and temperature. The volume of the tank is to be determined.

Assumptions Under specified conditions both O_2 and CO_2 can be treated as ideal gases, and the mixture as an ideal gas mixture.

Analysis The total number of moles is

$$N_m = N_{O_2} + N_{CO_2} = 8 \text{ kmol} + 10 \text{ kmol} = 18 \text{ kmol}$$

Then

$$V_m = \frac{N_m R_u T_m}{P_m} = \frac{(18 \text{ kmol})(8.314 \text{ kPa} \cdot \text{m}^3/\text{kmol} \cdot \text{K})(400 \text{ K})}{150 \text{ kPa}} = \mathbf{399.1 \text{ m}^3}$$

8 kmol O_2
10 kmol CO_2

400 K
150 kPa

13-37 The mass fractions of components of a gas mixture are given. The partial pressure of ethane is to be determined.

Properties The molar masses of CH_4 and C_2H_6 are 16.0 and 30.0 kg/kmol, respectively (Table A-1).

Analysis We consider 100 kg of this mixture. The mole numbers of each component are

$$N_{CH_4} = \frac{m_{CH_4}}{M_{CH_4}} = \frac{70 \text{ kg}}{16 \text{ kg/kmol}} = 4.375 \text{ kmol}$$

$$N_{C_2H_6} = \frac{m_{C_2H_6}}{M_{C_2H_6}} = \frac{30 \text{ kg}}{30 \text{ kg/kmol}} = 1.0 \text{ kmol}$$

The mole number of the mixture is

$$N_m = N_{CH_4} + N_{C_2H_6} = 4.375 + 1.0 = 5.375 \text{ kmol}$$

The mole fractions are

$$y_{CH_4} = \frac{N_{CH_4}}{N_m} = \frac{4.375 \text{ kmol}}{5.375 \text{ kmol}} = 0.8139$$

$$y_{C_2H_6} = \frac{N_{C_2H_6}}{N_m} = \frac{1.0 \text{ kmol}}{5.375 \text{ kmol}} = 0.1861$$

The final pressure of ethane in the final mixture is

$$P_{C_2H_6} = y_{C_2H_6} P_m = (0.1861)(130 \text{ kPa}) = \mathbf{24.19 \text{ kPa}}$$

70% CH_4
30% C_2H_6
(by mass)
100 m^3
130 kPa, 25°C

13-38E A mixture consists of liquid water and another fluid. The specific weight of this mixture is to be determined.

Properties The densities of water and the fluid are given to be 62.4 lbf/ft^3 and 50.0 lbf/ft^3 , respectively.

Analysis We consider 1 ft^3 of this mixture. The volume of the water in the mixture is 0.35 ft^3 which has a mass of

$$m_w = \rho_w \mathcal{V}_w = (62.4 \text{ lbf/ft}^3)(0.35 \text{ ft}^3) = 21.84 \text{ lbfm}$$

The weight of this water is

$$W_w = m_w g = (21.84 \text{ lbfm})(31.9 \text{ ft/s}^2) \left(\frac{1 \text{ lbf}}{32.174 \text{ lbfm} \cdot \text{ft/s}^2} \right) = 21.65 \text{ lbf}$$

Similarly, the volume of the second fluid is 0.65 ft^3 , and the mass of this fluid is

$$m_f = \rho_f \mathcal{V}_f = (50 \text{ lbf/ft}^3)(0.65 \text{ ft}^3) = 32.50 \text{ lbfm}$$

The weight of the fluid is

$$W_f = m_f g = (32.50 \text{ lbfm})(31.9 \text{ ft/s}^2) \left(\frac{1 \text{ lbf}}{32.174 \text{ lbfm} \cdot \text{ft/s}^2} \right) = 32.22 \text{ lbf}$$

The specific weight of this mixture is then

$$\gamma = \frac{W_w + W_f}{\mathcal{V}_w + \mathcal{V}_f} = \frac{(21.65 + 32.22) \text{ lbf}}{(0.35 + 0.65) \text{ ft}^3} = \mathbf{53.9 \text{ lbf/ft}^3}$$

<p>0.35 ft³ water 0.65 ft³ fluid</p>
--

13-39 The mole fractions of components of a gas mixture are given. The mass flow rate of the mixture is to be determined.

Properties The molar masses of air and CH_4 are 28.97 and 16.0 kg/kmol , respectively (Table A-1).

Analysis The molar fraction of air is

$$y_{\text{air}} = 1 - y_{\text{CH}_4} = 1 - 0.15 = 0.85$$

The molar mass of the mixture is determined from

$$\begin{aligned} M_m &= y_{\text{CH}_4} M_{\text{CH}_4} + y_{\text{air}} M_{\text{air}} \\ &= 0.15 \times 16 + 0.85 \times 28.97 \\ &= 27.02 \text{ kg/kmol} \end{aligned}$$

<p>15% CH_4 85% air (by mole)</p>
--

Given the engine displacement and speed and assuming that this is a 4-stroke engine (2 revolutions per cycle), the volume flow rate is determined from

$$\dot{\mathcal{V}} = \frac{\dot{n} \mathcal{V}_d}{2} = \frac{(3000 \text{ rev/min})(0.005 \text{ m}^3)}{2 \text{ rev/cycle}} = 7.5 \text{ m}^3/\text{min}$$

The specific volume of the mixture is

$$\nu = \frac{R_u T}{M_m P} = \frac{(8.314 \text{ kPa} \cdot \text{m}^3/\text{kmol} \cdot \text{K})(293 \text{ K})}{(27.02 \text{ kg/kmol})(80 \text{ kPa})} = 1.127 \text{ m}^3/\text{kg}$$

Hence the mass flow rate is

$$\dot{m} = \frac{\dot{\mathcal{V}}}{\nu} = \frac{7.5 \text{ m}^3/\text{min}}{1.127 \text{ m}^3/\text{kg}} = \mathbf{6.65 \text{ kg/min}}$$

13-40E The volumetric fractions of components of a natural gas mixture are given. The mass and volume flow rates of the mixture are to be determined.

Properties The molar masses of CH_4 and C_2H_6 are 16.0 and 30.0 lbm/lbmol, respectively (Table A-1E).

Analysis The molar mass of the mixture is determined from

$$M_m = y_{\text{CH}_4}M_{\text{CH}_4} + y_{\text{C}_2\text{H}_6}M_{\text{C}_2\text{H}_6} = 0.95 \times 16 + 0.05 \times 30 = 16.70 \text{ lbm/lbmol}$$

The specific volume of the mixture is

$$v = \frac{R_u T}{M_m P} = \frac{(10.73 \text{ psia} \cdot \text{ft}^3/\text{lbmol} \cdot \text{R})(520 \text{ R})}{(16.70 \text{ lbm/lbmol})(100 \text{ psia})} = 3.341 \text{ ft}^3/\text{lbm}$$

→	95% CH_4 5% C_2H_6 (by volume)
---	---

The volume flow rate is

$$\dot{V} = AV = \frac{\pi D^2}{4} V = \frac{\pi (36/12 \text{ ft})^2}{4} (10 \text{ ft/s}) = \mathbf{70.69 \text{ ft}^3/\text{s}}$$

and the mass flow rate is

$$\dot{m} = \frac{\dot{V}}{v} = \frac{70.69 \text{ ft}^3/\text{s}}{3.341 \text{ ft}^3/\text{lbm}} = \mathbf{21.16 \text{ lbm/s}}$$

13-41E The mass fractions of gases forming a mixture at a specified pressure and temperature are given. The mass of the gas mixture is to be determined using four methods.

Properties The molar masses of CH_4 and C_2H_6 are 16.0 and 30.0 lbm/lbmol, respectively (Table A-1E).

Analysis (a) We consider 100 lbm of this mixture. Then the mole numbers of each component are

$$N_{\text{CH}_4} = \frac{m_{\text{CH}_4}}{M_{\text{CH}_4}} = \frac{75 \text{ lbm}}{16 \text{ lbm/lbmol}} = 4.6875 \text{ lbmol}$$

$$N_{\text{C}_2\text{H}_6} = \frac{m_{\text{C}_2\text{H}_6}}{M_{\text{C}_2\text{H}_6}} = \frac{25 \text{ lbm}}{30 \text{ lbm/lbmol}} = 0.8333 \text{ lbmol}$$

The mole number of the mixture and the mole fractions are

$$N_m = 4.6875 + 0.8333 = 5.5208 \text{ lbmol}$$

$$y_{\text{CH}_4} = \frac{N_{\text{CH}_4}}{N_m} = \frac{4.6875 \text{ lbmol}}{5.5208 \text{ lbmol}} = 0.8491$$

$$y_{\text{C}_2\text{H}_6} = \frac{N_{\text{C}_2\text{H}_6}}{N_m} = \frac{0.8333 \text{ lbmol}}{5.5208 \text{ lbmol}} = 0.1509$$

75% CH_4
25% C_2H_6
(by mass)
2000 psia
300°F

Then the apparent molecular weight of the mixture becomes

$$M_m = \frac{m_m}{N_m} = \frac{100 \text{ lbm}}{5.5208 \text{ lbmol}} = 18.11 \text{ lbm/lbmol}$$

The apparent gas constant of the mixture is

$$R = \frac{R_u}{M_m} = \frac{10.73 \text{ psia} \cdot \text{ft}^3/\text{lbmol} \cdot \text{R}}{18.11 \text{ lbm/lbmol}} = 0.5925 \text{ psia} \cdot \text{ft}^3/\text{lbm} \cdot \text{R}$$

The mass of this mixture in a 1 million ft^3 tank is

$$m = \frac{P\mathcal{V}}{RT} = \frac{(2000 \text{ psia})(1 \times 10^6 \text{ ft}^3)}{(0.5925 \text{ psia} \cdot \text{ft}^3/\text{lbm} \cdot \text{R})(760 \text{ R})} = \mathbf{4.441 \times 10^6 \text{ lbm}}$$

(b) To use the Amagat's law for this real gas mixture, we first need the compressibility factor of each component at the mixture temperature and pressure. The compressibility factors are obtained using Fig. A-15 to be

$$\left. \begin{aligned} T_{R,\text{CH}_4} &= \frac{T_m}{T_{\text{cr},\text{CH}_4}} = \frac{760 \text{ R}}{343.9 \text{ R}} = 2.210 \\ P_{R,\text{CH}_4} &= \frac{P_m}{P_{\text{cr},\text{CH}_4}} = \frac{2000 \text{ psia}}{673 \text{ psia}} = 2.972 \end{aligned} \right\} Z_{\text{CH}_4} = 0.98$$

$$\left. \begin{aligned} T_{R,\text{C}_2\text{H}_6} &= \frac{760 \text{ R}}{549.8 \text{ R}} = 1.382 \\ P_{R,\text{C}_2\text{H}_6} &= \frac{1500 \text{ psia}}{708 \text{ psia}} = 2.119 \end{aligned} \right\} Z_{\text{C}_2\text{H}_6} = 0.77$$

Then,

$$Z_m = \sum y_i Z_i = y_{\text{CH}_4} Z_{\text{CH}_4} + y_{\text{C}_2\text{H}_6} Z_{\text{C}_2\text{H}_6} = (0.8491)(0.98) + (0.1509)(0.77) = 0.9483$$

$$m = \frac{P\mathcal{V}}{Z_m RT} = \frac{(2000 \text{ psia})(1 \times 10^6 \text{ ft}^3)}{(0.9483)(0.5925 \text{ psia} \cdot \text{ft}^3/\text{lbm} \cdot \text{R})(760 \text{ R})} = \mathbf{4.684 \times 10^6 \text{ lbm}}$$

(c) To use Dalton's law with compressibility factors: (Fig. A-15)

$$\left. \begin{aligned} T_{R,\text{CH}_4} &= 2.210 \\ \nu_{R,\text{CH}_4} &= \frac{\nu_m/m_{\text{CH}_4}}{R_{\text{CH}_4} T_{\text{cr},\text{CH}_4} / P_{\text{cr},\text{CH}_4}} = \frac{(1 \times 10^6 \text{ ft}^3)/(4.441 \times 10^6 \times 0.75 \text{ lbm})}{(0.6688 \text{ psia} \cdot \text{ft}^3/\text{lbm} \cdot \text{R})(343.9 \text{ R})/(673 \text{ psia})} = 0.8782 \end{aligned} \right\} Z_{\text{CH}_4} = 0.98$$

$$T_{R,C_2H_6} = 1.382$$

$$\nu_{R,C_2H_6} = \frac{\mathcal{V}_m/m_{C_2H_6}}{RT_{cr,C_2H_6}/P_{cr,C_2H_6}} = \frac{(1 \times 10^6 \text{ ft}^3)/(4.441 \times 10^6 \times 0.25 \text{ lbm})}{(0.3574 \text{ psia} \cdot \text{ft}^3/\text{lbm} \cdot \text{R})(549.8 \text{ R})/(708 \text{ psia})} = 3.244 \quad \left. \vphantom{\nu_{R,C_2H_6}} \right\} Z_{CH_4} = 0.92$$

Note that we used $m = 4.441 \times 10^6 \times 0.25 \text{ lbm}$ in above calculations, the value obtained by ideal gas behavior. The solution normally requires iteration until the assumed and calculated mass values match. The mass of the component gas is obtained by multiplying the mass of the mixture by its mass fraction. Then,

$$Z_m = \sum y_i Z_i = y_{CH_4} Z_{CH_4} + y_{C_2H_6} Z_{C_2H_6} = (0.8491)(0.98) + (0.1509)(0.92) = 0.9709$$

$$m = \frac{P\mathcal{V}}{Z_m RT} = \frac{(2000 \text{ psia})(1 \times 10^6 \text{ ft}^3)}{(0.9709)(0.5925 \text{ psia} \cdot \text{ft}^3/\text{lbm} \cdot \text{R})(760 \text{ R})} = \mathbf{4.575 \times 10^6 \text{ lbm}}$$

This mass is sufficiently close to the assumed mass value of $4.441 \times 10^6 \times 0.25 \text{ lbm}$. Therefore, there is no need to repeat the calculations at this calculated mass.

(d) To use Kay's rule, we need to determine the pseudo-critical temperature and pseudo-critical pressure of the mixture using the critical point properties of gases.

$$T'_{cr,m} = \sum y_i T_{cr,i} = y_{CH_4} T_{cr,CH_4} + y_{C_2H_6} T_{cr,C_2H_6}$$

$$= (0.8491)(343.9 \text{ R}) + (0.1509)(549.8 \text{ R})$$

$$= 375.0 \text{ R}$$

$$P'_{cr,m} = \sum y_i P_{cr,i} = y_{CH_4} P_{cr,CH_4} + y_{C_2H_6} P_{cr,C_2H_6}$$

$$= (0.8491)(673 \text{ psia}) + (0.1509)(708 \text{ psia})$$

$$= 678.3 \text{ psia}$$

Then,

$$T_R = \frac{T_m}{T'_{cr,m}} = \frac{760 \text{ R}}{375.0 \text{ R}} = 2.027$$

$$P_R = \frac{P_m}{P'_{cr,m}} = \frac{2000 \text{ psia}}{678.3 \text{ psia}} = 2.949 \quad \left. \vphantom{P_R} \right\} Z_m = 0.97 \quad (\text{Fig. A-15})$$

$$m = \frac{P\mathcal{V}}{Z_m RT} = \frac{(2000 \text{ psia})(1 \times 10^6 \text{ ft}^3)}{(0.97)(0.5925 \text{ psia} \cdot \text{ft}^3/\text{lbm} \cdot \text{R})(760 \text{ R})} = \mathbf{4.579 \times 10^6 \text{ lbm}}$$

13-42 The volumetric analysis of a mixture of gases is given. The volumetric and mass flow rates are to be determined using three methods.

Properties The molar masses of O₂, N₂, CO₂, and CH₄ are 32.0, 28.0, 44.0, and 16.0 kg/kmol, respectively (Table A-1).

Analysis (a) We consider 100 kmol of this mixture. Noting that volume fractions are equal to the mole fractions, mass of each component are

$$\begin{aligned} m_{\text{O}_2} &= N_{\text{O}_2} M_{\text{O}_2} = (30 \text{ kmol})(32 \text{ kg/kmol}) = 960 \text{ kg} \\ m_{\text{N}_2} &= N_{\text{N}_2} M_{\text{N}_2} = (40 \text{ kmol})(28 \text{ kg/kmol}) = 1120 \text{ kg} \\ m_{\text{CO}_2} &= N_{\text{CO}_2} M_{\text{CO}_2} = (10 \text{ kmol})(44 \text{ kg/kmol}) = 440 \text{ kg} \\ m_{\text{CH}_4} &= N_{\text{CH}_4} M_{\text{CH}_4} = (20 \text{ kmol})(16 \text{ kg/kmol}) = 320 \text{ kg} \end{aligned}$$

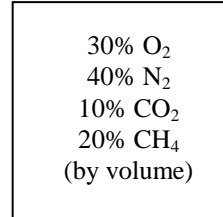

The total mass is

$$\begin{aligned} m_m &= m_{\text{O}_2} + m_{\text{N}_2} + m_{\text{CO}_2} + m_{\text{CH}_4} \\ &= 960 + 1120 + 440 + 320 \\ &= 2840 \text{ kg} \end{aligned}$$

The apparent molecular weight of the mixture is

$$M_m = \frac{m_m}{N_m} = \frac{2840 \text{ kg}}{100 \text{ kmol}} = 28.40 \text{ kg/kmol}$$

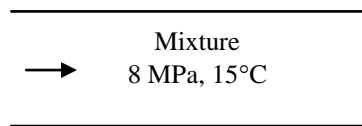

The apparent gas constant of the mixture is

$$R = \frac{R_u}{M_m} = \frac{8.314 \text{ kJ/kmol} \cdot \text{K}}{28.40 \text{ kg/kmol}} = 0.2927 \text{ kJ/kg} \cdot \text{K}$$

The specific volume of the mixture is

$$\nu = \frac{RT}{P} = \frac{(0.2927 \text{ kPa} \cdot \text{m}^3/\text{kg} \cdot \text{K})(288 \text{ K})}{8000 \text{ kPa}} = 0.01054 \text{ m}^3/\text{kg}$$

The volume flow rate is

$$\dot{V} = AV = \frac{\pi D^2}{4} V = \frac{\pi(0.016 \text{ m})^2}{4} (5 \text{ m/s}) = \mathbf{0.001005 \text{ m}^3/\text{s}}$$

and the mass flow rate is

$$\dot{m} = \frac{\dot{V}}{\nu} = \frac{0.001005 \text{ m}^3/\text{s}}{0.01054 \text{ m}^3/\text{kg}} = \mathbf{0.09535 \text{ kg/s}}$$

(b) To use the Amagat's law for this real gas mixture, we first need the mole fractions and the Z of each component at the mixture temperature and pressure. The compressibility factors are obtained using Fig. A-15 to be

$$\left. \begin{aligned} T_{R,\text{O}_2} &= \frac{T_m}{T_{\text{cr},\text{O}_2}} = \frac{288 \text{ K}}{154.8 \text{ K}} = 1.860 \\ P_{R,\text{O}_2} &= \frac{P_m}{P_{\text{cr},\text{O}_2}} = \frac{8 \text{ MPa}}{5.08 \text{ MPa}} = 1.575 \end{aligned} \right\} Z_{\text{O}_2} = 0.95$$

$$\left. \begin{aligned} T_{R,\text{N}_2} &= \frac{288 \text{ K}}{126.2 \text{ K}} = 2.282 \\ P_{R,\text{N}_2} &= \frac{8 \text{ MPa}}{3.39 \text{ MPa}} = 2.360 \end{aligned} \right\} Z_{\text{N}_2} = 0.99$$

$$\left. \begin{aligned} T_{R,\text{CO}_2} &= \frac{288 \text{ K}}{304.2 \text{ K}} = 0.947 \\ P_{R,\text{CO}_2} &= \frac{8 \text{ MPa}}{7.39 \text{ MPa}} = 1.083 \end{aligned} \right\} Z_{\text{CO}_2} = 0.199$$

$$\left. \begin{aligned} T_{R,\text{CH}_4} &= \frac{288 \text{ K}}{191.1 \text{ K}} = 1.507 \\ P_{R,\text{CH}_4} &= \frac{8 \text{ MPa}}{4.64 \text{ MPa}} = 1.724 \end{aligned} \right\} Z_{\text{CH}_4} = 0.85$$

and

$$\begin{aligned}
 Z_m &= \sum y_i Z_i = y_{O_2} Z_{O_2} + y_{N_2} Z_{N_2} + y_{CO_2} Z_{CO_2} + y_{CH_4} Z_{CH_4} \\
 &= (0.30)(0.95) + (0.40)(0.99) + (0.10)(0.199) + (0.20)(0.85) \\
 &= 0.8709
 \end{aligned}$$

Then,

$$\nu = \frac{Z_m RT}{P} = \frac{(0.8709)(0.2927 \text{ kPa} \cdot \text{m}^3/\text{kg} \cdot \text{K})(288 \text{ K})}{8000 \text{ kPa}} = 0.009178 \text{ m}^3/\text{kg}$$

$$\dot{\nu} = 0.001005 \text{ m}^3/\text{s}$$

$$\dot{m} = \frac{\dot{\nu}}{\nu} = \frac{0.001005 \text{ m}^3/\text{s}}{0.009178 \text{ m}^3/\text{kg}} = 0.1095 \text{ kg/s}$$

(c) To use Kay's rule, we need to determine the pseudo-critical temperature and pseudo-critical pressure of the mixture using the critical point properties of mixture gases.

$$\begin{aligned}
 T'_{cr,m} &= \sum y_i T_{cr,i} = y_{O_2} T_{cr,O_2} + y_{N_2} T_{cr,N_2} + y_{CO_2} T_{cr,CO_2} + y_{CH_4} T_{cr,CH_4} \\
 &= (0.30)(154.8 \text{ K}) + (0.40)(126.2 \text{ K}) + (0.10)(304.2 \text{ K}) + (0.20)(191.1 \text{ K}) \\
 &= 165.6 \text{ K}
 \end{aligned}$$

$$\begin{aligned}
 P'_{cr,m} &= \sum y_i P_{cr,i} = y_{O_2} P_{cr,O_2} + y_{N_2} P_{cr,N_2} + y_{CO_2} P_{cr,CO_2} + y_{CH_4} P_{cr,CH_4} \\
 &= (0.30)(5.08 \text{ MPa}) + (0.40)(3.39 \text{ MPa}) + (0.10)(7.39 \text{ MPa}) + (0.20)(4.64 \text{ MPa}) \\
 &= 4.547 \text{ MPa}
 \end{aligned}$$

and

$$\left. \begin{aligned}
 T_R &= \frac{T_m}{T'_{cr,m}} = \frac{288 \text{ K}}{165.6 \text{ K}} = 1.739 \\
 P_R &= \frac{P_m}{P'_{cr,m}} = \frac{8 \text{ MPa}}{4.547 \text{ MPa}} = 1.759
 \end{aligned} \right\} Z_m = 0.92 \quad (\text{Fig. A-15})$$

Then,

$$\nu = \frac{Z_m RT}{P} = \frac{(0.92)(0.2927 \text{ kPa} \cdot \text{m}^3/\text{kg} \cdot \text{K})(288 \text{ K})}{8000 \text{ kPa}} = 0.009694 \text{ m}^3/\text{kg}$$

$$\dot{\nu} = 0.001005 \text{ m}^3/\text{s}$$

$$\dot{m} = \frac{\dot{\nu}}{\nu} = \frac{0.001005 \text{ m}^3/\text{s}}{0.009694 \text{ m}^3/\text{kg}} = 0.1037 \text{ kg/s}$$

13-43E The mole numbers, temperatures, and pressures of two gases forming a mixture are given. For a specified final temperature, the pressure of the mixture is to be determined using two methods.

Properties The critical properties of Ar are $T_{cr} = 272$ R and $P_{cr} = 705$ psia. The critical properties of N_2 are $T_{cr} = 227.1$ R and $P_{cr} = 492$ psia (Table A-1E).

Analysis (a) Under specified conditions both Ar and N_2 will considerably deviate from the ideal gas behavior. Treating the mixture as an ideal gas,

$$\left. \begin{array}{l} \text{Initial state: } P_1 V_1 = N_1 R_u T_1 \\ \text{Final state: } P_2 V_2 = N_2 R_u T_2 \end{array} \right\} P_2 = \frac{N_2 T_2}{N_1 T_1} P_1 = \frac{(4)(360 \text{ R})}{(1)(400 \text{ R})} (750 \text{ psia}) = \mathbf{2700 \text{ psia}}$$

(b) Initially,

$$\left. \begin{array}{l} T_R = \frac{T_1}{T_{cr,Ar}} = \frac{400 \text{ R}}{272 \text{ R}} = 1.47 \\ P_R = \frac{P_1}{P_{cr,Ar}} = \frac{750 \text{ psia}}{705 \text{ psia}} = 1.07 \end{array} \right\} Z_{Ar} = 0.90 \text{ (Fig. A-15)}$$

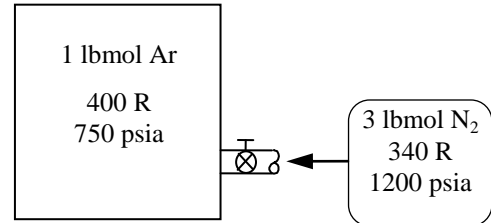

Then the volume of the tank is

$$V = \frac{Z N_{Ar} R_u T}{P} = \frac{(0.90)(1 \text{ lbmol})(10.73 \text{ psia} \cdot \text{ft}^3/\text{lbmol} \cdot \text{R})(400 \text{ R})}{750 \text{ psia}} = 5.15 \text{ ft}^3$$

After mixing,

$$\left. \begin{array}{l} T_{R,Ar} = \frac{T_m}{T_{cr,Ar}} = \frac{360 \text{ R}}{272 \text{ R}} = 1.324 \\ \nu_{R,Ar} = \frac{\nu_{Ar}}{R_u T_{cr,Ar} / P_{cr,Ar}} = \frac{\nu_m / N_{Ar}}{R_u T_{cr,Ar} / P_{cr,Ar}} \\ = \frac{(5.15 \text{ ft}^3)/(1 \text{ lbmol})}{(10.73 \text{ psia} \cdot \text{ft}^3/\text{lbmol} \cdot \text{R})(272 \text{ R})/(705 \text{ psia})} = 1.244 \end{array} \right\} P_R = 0.82 \text{ (Fig. A-15)}$$

$$\left. \begin{array}{l} T_{R,N_2} = \frac{T_m}{T_{cr,N_2}} = \frac{360 \text{ R}}{227.1 \text{ R}} = 1.585 \\ \nu_{R,N_2} = \frac{\nu_{N_2}}{R_u T_{cr,N_2} / P_{cr,N_2}} = \frac{\nu_m / N_{N_2}}{R_u T_{cr,N_2} / P_{cr,N_2}} \\ = \frac{(5.15 \text{ ft}^3)/(3 \text{ lbmol})}{(10.73 \text{ psia} \cdot \text{ft}^3/\text{lbmol} \cdot \text{R})(227.1 \text{ R})/(492 \text{ psia})} = 0.347 \end{array} \right\} P_R = 3.85 \text{ (Fig. A-15)}$$

Thus,

$$P_{Ar} = (P_R P_{cr})_{Ar} = (0.82)(705 \text{ psia}) = 578 \text{ psia}$$

$$P_{N_2} = (P_R P_{cr})_{N_2} = (3.85)(492 \text{ psia}) = 1894 \text{ psia}$$

and

$$P_m = P_{Ar} + P_{N_2} = 578 \text{ psia} + 1894 \text{ psia} = \mathbf{2472 \text{ psia}}$$

Properties of Gas Mixtures

13-44C Yes. Yes (extensive property).

13-45C No (intensive property).

13-46C The answers are the same for entropy.

13-47C Yes. Yes (conservation of energy).

13-48C We have to use the partial pressure.

13-49C No, this is an approximate approach. It assumes a component behaves as if it existed alone at the mixture temperature and pressure (i.e., it disregards the influence of dissimilar molecules on each other.)

13-50 The volume fractions of components of a gas mixture are given. This mixture is heated while flowing through a tube at constant pressure. The heat transfer to the mixture per unit mass of the mixture is to be determined.

Assumptions All gases will be modeled as ideal gases with constant specific heats.

Properties The molar masses of O₂, N₂, CO₂, and CH₄ are 32.0, 28.0, 44.0, and 16.0 kg/kmol, respectively (Table A-1). The constant-pressure specific heats of these gases at room temperature are 0.918, 1.039, 0.846, and 2.2537 kJ/kg·K, respectively (Table A-2a).

Analysis We consider 100 kmol of this mixture. Noting that volume fractions are equal to the mole fractions, mass of each component are

$$\begin{aligned} m_{\text{O}_2} &= N_{\text{O}_2} M_{\text{O}_2} = (30 \text{ kmol})(32 \text{ kg/kmol}) = 960 \text{ kg} \\ m_{\text{N}_2} &= N_{\text{N}_2} M_{\text{N}_2} = (40 \text{ kmol})(28 \text{ kg/kmol}) = 1120 \text{ kg} \\ m_{\text{CO}_2} &= N_{\text{CO}_2} M_{\text{CO}_2} = (10 \text{ kmol})(44 \text{ kg/kmol}) = 440 \text{ kg} \\ m_{\text{CH}_4} &= N_{\text{CH}_4} M_{\text{CH}_4} = (20 \text{ kmol})(16 \text{ kg/kmol}) = 320 \text{ kg} \end{aligned}$$

The total mass is

$$\begin{aligned} m_m &= m_{\text{O}_2} + m_{\text{N}_2} + m_{\text{CO}_2} + m_{\text{CH}_4} \\ &= 960 + 1120 + 440 + 320 \\ &= 2840 \text{ kg} \end{aligned}$$

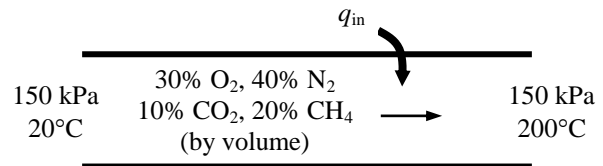

Then the mass fractions are

$$\begin{aligned} \text{mf}_{\text{O}_2} &= \frac{m_{\text{O}_2}}{m_m} = \frac{960 \text{ kg}}{2840 \text{ kg}} = 0.3380 \\ \text{mf}_{\text{N}_2} &= \frac{m_{\text{N}_2}}{m_m} = \frac{1120 \text{ kg}}{2840 \text{ kg}} = 0.3944 \\ \text{mf}_{\text{CO}_2} &= \frac{m_{\text{CO}_2}}{m_m} = \frac{440 \text{ kg}}{2840 \text{ kg}} = 0.1549 \\ \text{mf}_{\text{CH}_4} &= \frac{m_{\text{CH}_4}}{m_m} = \frac{320 \text{ kg}}{2840 \text{ kg}} = 0.1127 \end{aligned}$$

The constant-pressure specific heat of the mixture is determined from

$$\begin{aligned} c_p &= \text{mf}_{\text{O}_2} c_{p,\text{O}_2} + \text{mf}_{\text{N}_2} c_{p,\text{N}_2} + \text{mf}_{\text{CO}_2} c_{p,\text{CO}_2} + \text{mf}_{\text{CH}_4} c_{p,\text{CH}_4} \\ &= 0.3380 \times 0.918 + 0.3944 \times 1.039 + 0.1549 \times 0.846 + 0.1127 \times 2.2537 \\ &= 1.1051 \text{ kJ/kg} \cdot \text{K} \end{aligned}$$

An energy balance on the tube gives

$$q_{\text{in}} = c_p (T_2 - T_1) = (1.1051 \text{ kJ/kg} \cdot \text{K})(200 - 20) \text{ K} = \mathbf{199 \text{ kJ/kg}}$$

13-51 Oxygen, nitrogen, and argon gases are supplied from separate tanks at different temperatures to form a mixture. The total entropy change for the mixing process is to be determined.

Assumptions Under specified conditions all N_2 , O_2 , and argon can be treated as ideal gases, and the mixture as an ideal gas mixture.

Properties The molar masses of O_2 , N_2 , and Ar are 32.0, 28.0, and 40.0 kg/kmol, respectively (Table A-1). The properties of Argon are $R = 0.2081$ kJ/kg.K and $c_p = 0.5203$ kJ/kg.K (Table A-2).

Analysis Note that volume fractions are equal to mole fractions in ideal gas mixtures. The partial pressures in the mixture are

$$P_{O_2,2} = y_{O_2} P_m = (0.21)(200 \text{ kPa}) = 42 \text{ kPa}$$

$$P_{N_2,2} = y_{N_2} P_m = (0.78)(200 \text{ kPa}) = 156 \text{ kPa}$$

$$P_{Ar,2} = y_{Ar} P_m = (0.01)(200 \text{ kPa}) = 2 \text{ kPa}$$

The molar mass of the mixture is determined to be

$$\begin{aligned} M_m &= y_{O_2} M_{O_2} + y_{N_2} M_{N_2} + y_{Ar} M_{Ar} \\ &= (0.21)(32 \text{ kg/kmol}) + (0.78)(28) + (0.01)(40) = 28.96 \text{ kg/kmol} \end{aligned}$$

The mass fractions are

$$mf_{O_2} = y_{O_2} \frac{M_{O_2}}{M_m} = (0.21) \frac{32 \text{ kg/kmol}}{28.96 \text{ kg/kmol}} = 0.2320$$

$$mf_{N_2} = y_{N_2} \frac{M_{N_2}}{M_m} = (0.78) \frac{28 \text{ kg/kmol}}{28.96 \text{ kg/kmol}} = 0.7541$$

$$mf_{Ar} = y_{Ar} \frac{M_{Ar}}{M_m} = (0.01) \frac{40 \text{ kg/kmol}}{28.96 \text{ kg/kmol}} = 0.0138$$

The final temperature of the mixture is needed. The conservation of energy on a unit mass basis for steady flow mixing with no heat transfer or work allows calculation of mixture temperature. All components of the exit mixture have the same common temperature, T_m . We obtain the properties of O_2 and N_2 from EES:

$$\begin{aligned} e_{in} &= e_{out} \\ mf_{O_2} h_{@10^\circ\text{C}} + mf_{N_2} h_{@60^\circ\text{C}} + mf_{Ar} c_{p,Ar} T_{Ar,1} &= mf_{O_2} h_{@T_m} + mf_{N_2} h_{@T_m} + mf_{Ar} c_{p,Ar} T_m \\ (0.2320)(-13.85) + (0.7541)(36.47) + (0.0138)(0.5203)(200) &= (0.2320)h_{@T_m} + (0.7541)h_{@T_m} \\ &\quad + (0.0138)(0.5203)T_m \end{aligned}$$

Solving this equation in EES we find $T_m = 50.4^\circ\text{C}$. The entropies of O_2 and N_2 are obtained from EES to be

$$T = 10^\circ\text{C}, P = 200 \text{ kPa} \longrightarrow s_{O_2,1} = 6.1797 \text{ kJ/kg.K}$$

$$T = 50.4^\circ\text{C}, P = 42 \text{ kPa} \longrightarrow s_{O_2,2} = 6.7082 \text{ kJ/kg.K}$$

$$T = 60^\circ\text{C}, P = 200 \text{ kPa} \longrightarrow s_{N_2,1} = 6.7461 \text{ kJ/kg.K}$$

$$T = 50.4^\circ\text{C}, P = 156 \text{ kPa} \longrightarrow s_{N_2,2} = 6.7893 \text{ kJ/kg.K}$$

The entropy changes are

$$\Delta s_{O_2} = s_{O_2,2} - s_{O_2,1} = 6.7082 - 6.1797 = 0.5284 \text{ kJ/kg.K}$$

$$\Delta s_{N_2} = s_{N_2,2} - s_{N_2,1} = 6.7893 - 6.7461 = 0.04321 \text{ kJ/kg.K}$$

$$\Delta s_{Ar} = c_p \ln \frac{T_2}{T_1} - R \ln \frac{P_2}{P_1} = (0.5203) \ln \left(\frac{50.4 + 273}{200 + 273} \right) - (0.2081) \ln \left(\frac{2}{200} \right) = 0.7605 \text{ kJ/kg.K}$$

The total entropy change is

$$\begin{aligned} \Delta s_{total} &= mf_{O_2} \Delta s_{O_2} + mf_{N_2} \Delta s_{N_2} + mf_{Ar} \Delta s_{Ar} \\ &= (0.2320)(0.5284) + (0.7541)(0.04321) + (0.0138)(0.7605) = \mathbf{0.1656 \text{ kJ/kg.K}} \end{aligned}$$

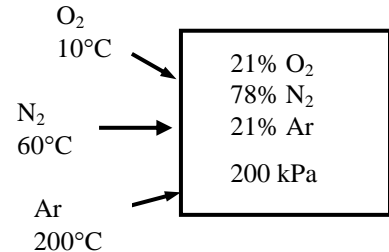

13-52E A mixture of helium and nitrogen is heated at constant pressure in a closed system. The work produced is to be determined.

Assumptions **1** Helium and nitrogen are ideal gases. **2** The process is reversible.

Properties The mole numbers of helium and nitrogen are 4.0 and 28.0 lbm/lbmol, respectively (Table A-1E).

Analysis One lbm of this mixture consists of 0.35 lbm of nitrogen and 0.65 lbm of helium or $0.35 \text{ lbm}/(28.0 \text{ lbm/lbmol}) = 0.0125 \text{ lbmol}$ of nitrogen and $0.65 \text{ lbm}/(4.0 \text{ lbm/lbmol}) = 0.1625 \text{ lbmol}$ of helium. The total mole is $0.0125 + 0.1625 = 0.175 \text{ lbmol}$. The constituent mole fraction are then

$$y_{\text{N}_2} = \frac{N_{\text{N}_2}}{N_{\text{total}}} = \frac{0.0125 \text{ lbmol}}{0.175 \text{ lbmol}} = 0.07143$$

$$y_{\text{He}} = \frac{N_{\text{He}}}{N_{\text{total}}} = \frac{0.1625 \text{ lbmol}}{0.175 \text{ lbmol}} = 0.9286$$

The effective molecular weight of this mixture is

$$\begin{aligned} M &= y_{\text{N}_2} M_{\text{N}_2} + y_{\text{He}} M_{\text{He}} \\ &= (0.07143)(28) + (0.9286)(4) \\ &= 5.714 \text{ lbm/lbmol} \end{aligned}$$

The work done is determined from

$$\begin{aligned} w &= \int_1^2 P d\mathbf{v} = P_2 \mathbf{v}_2 - P_1 \mathbf{v}_1 = R(T_2 - T_1) \\ &= \frac{R_u}{M} (T_2 - T_1) = \frac{1.9858 \text{ Btu/lbmol} \cdot \text{R}}{5.714 \text{ lbm/lbmol}} (500 - 100) \text{R} \\ &= \mathbf{139.0 \text{ Btu/lbm}} \end{aligned}$$

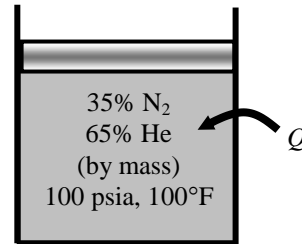

13-53 The volumetric fractions of the constituents of a mixture are given. The makeup of the mixture on a mass basis and the enthalpy change per unit mass of mixture during a process are to be determined.

Assumptions Under specified conditions all N_2 , O_2 , and CO_2 can be treated as ideal gases, and the mixture as an ideal gas mixture.

Properties The molar masses of CO_2 , O_2 , and N_2 are 44.0, 32.0, and 28.0 kg/kmol, respectively (Table A-1).

Analysis Noting that volume fractions are equal to mole fractions in ideal gas mixtures, the molar mass of the mixture is determined to be

$$M_m = y_{CO_2} M_{CO_2} + y_{O_2} M_{O_2} + y_{N_2} M_{N_2} = (0.20)(44 \text{ kg/kmol}) + (0.10)(32) + (0.70)(28) = 31.60 \text{ kg/kmol}$$

The mass fractions are

$$mf_{CO_2} = y_{CO_2} \frac{M_{CO_2}}{M_m} = (0.20) \frac{44 \text{ kg/kmol}}{31.60 \text{ kg/kmol}} = \mathbf{0.2785}$$

$$mf_{O_2} = y_{O_2} \frac{M_{O_2}}{M_m} = (0.10) \frac{32 \text{ kg/kmol}}{31.60 \text{ kg/kmol}} = \mathbf{0.1013}$$

$$mf_{N_2} = y_{N_2} \frac{M_{N_2}}{M_m} = (0.70) \frac{28 \text{ kg/kmol}}{31.60 \text{ kg/kmol}} = \mathbf{0.6203}$$

70% N_2 10% O_2 20% CO_2

$T_1 = 300 \text{ K}$ $T_2 = 500 \text{ K}$
--

The enthalpy change of each gas and the enthalpy change of the mixture are (from Tables A-18-20)

$$\Delta h_{CO_2} = \frac{\bar{h}_{@500\text{K}} - \bar{h}_{@300\text{K}}}{M_{CO_2}} = \frac{(17,678 - 9431) \text{ kJ/kmol}}{44 \text{ kg/kmol}} = 187.43 \text{ kJ/kg}$$

$$\Delta h_{O_2} = \frac{\bar{h}_{@500\text{K}} - \bar{h}_{@300\text{K}}}{M_{O_2}} = \frac{(14,770 - 8736) \text{ kJ/kmol}}{32 \text{ kg/kmol}} = 188.56 \text{ kJ/kg}$$

$$\Delta h_{N_2} = \frac{\bar{h}_{@500\text{K}} - \bar{h}_{@300\text{K}}}{M_{N_2}} = \frac{(14,581 - 8723) \text{ kJ/kmol}}{28 \text{ kg/kmol}} = 209.21 \text{ kJ/kg}$$

$$\begin{aligned} \Delta h_m &= mf_{CO_2} \Delta h_{CO_2} + mf_{O_2} \Delta h_{O_2} + mf_{N_2} \Delta h_{N_2} \\ &= (0.2785)(187.43) + (0.1013)(188.56) + (0.6203)(209.21) \\ &= \mathbf{201.1 \text{ kJ/kg}} \end{aligned}$$

13-54 The temperatures and pressures of two gases forming a mixture are given. The final mixture temperature and pressure are to be determined.

Assumptions 1 Under specified conditions both Ne and Ar can be treated as ideal gases, and the mixture as an ideal gas mixture. **2** There are no other forms of work involved.

Properties The molar masses and specific heats of Ne and Ar are 20.18 kg/kmol, 39.95 kg/kmol, 0.6179 kJ/kg·°C, and 0.3122 kJ/kg·°C, respectively. (Tables A-1 and A-2).

Analysis The mole number of each gas is

$$N_{\text{Ne}} = \left(\frac{P_1 V_1}{R_u T_1} \right)_{\text{Ne}} = \frac{(100 \text{ kPa})(0.45 \text{ m}^3)}{(8.314 \text{ kPa} \cdot \text{m}^3/\text{kmol} \cdot \text{K})(293 \text{ K})} = 0.0185 \text{ kmol}$$

$$N_{\text{Ar}} = \left(\frac{P_1 V_1}{R_u T_1} \right)_{\text{Ar}} = \frac{(200 \text{ kPa})(0.45 \text{ m}^3)}{(8.314 \text{ kPa} \cdot \text{m}^3/\text{kmol} \cdot \text{K})(323 \text{ K})} = 0.0335 \text{ kmol}$$

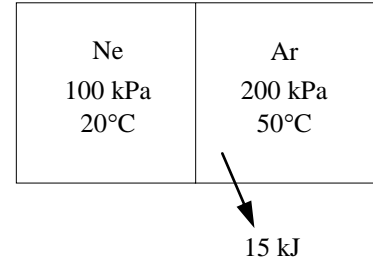

Thus,

$$N_m = N_{\text{Ne}} + N_{\text{Ar}} = 0.0185 \text{ kmol} + 0.0335 \text{ kmol} = 0.0520 \text{ kmol}$$

(a) We take both gases as the system. No work or mass crosses the system boundary, therefore this is a closed system with $W = 0$. Then the conservation of energy equation for this closed system reduces to

$$E_{\text{in}} - E_{\text{out}} = \Delta E_{\text{system}}$$

$$-Q_{\text{out}} = \Delta U = \Delta U_{\text{Ne}} + \Delta U_{\text{Ar}} \longrightarrow -Q_{\text{out}} = [mc_v(T_m - T_1)]_{\text{Ne}} + [mc_v(T_m - T_1)]_{\text{Ar}}$$

Using c_v values at room temperature and noting that $m = NM$, the final temperature of the mixture is determined to be

$$-15 \text{ kJ} = (0.0185 \times 20.18 \text{ kg})(0.6179 \text{ kJ/kg} \cdot \text{°C})(T_m - 20\text{°C})$$

$$+ (0.0335 \times 39.95 \text{ kg})(0.3122 \text{ kJ/kg} \cdot \text{°C})(T_m - 50\text{°C})$$

$$T_m = \mathbf{16.2\text{°C}} \quad (289.2 \text{ K})$$

(b) The final pressure in the tank is determined from

$$P_m = \frac{N_m R_u T_m}{V_m} = \frac{(0.052 \text{ kmol})(8.314 \text{ kPa} \cdot \text{m}^3/\text{kmol} \cdot \text{K})(289.2 \text{ K})}{0.9 \text{ m}^3} = \mathbf{138.9 \text{ kPa}}$$

13-55 The temperatures and pressures of two gases forming a mixture are given. The final mixture temperature and pressure are to be determined.

Assumptions 1 Under specified conditions both Ne and Ar can be treated as ideal gases, and the mixture as an ideal gas mixture. **2** There are no other forms of work involved.

Properties The molar masses and specific heats of Ne and Ar are 20.18 kg/kmol, 39.95 kg/kmol, 0.6179 kJ/kg·°C, and 0.3122 kJ/kg·°C, respectively. (Tables A-1 and A-2b).

Analysis The mole number of each gas is

$$N_{\text{Ne}} = \left(\frac{P_1 V_1}{R_u T_1} \right)_{\text{Ne}} = \frac{(100 \text{ kPa})(0.45 \text{ m}^3)}{(8.314 \text{ kPa} \cdot \text{m}^3/\text{kmol} \cdot \text{K})(293 \text{ K})} = 0.0185 \text{ kmol}$$

$$N_{\text{Ar}} = \left(\frac{P_1 V_1}{R_u T_1} \right)_{\text{Ar}} = \frac{(200 \text{ kPa})(0.45 \text{ m}^3)}{(8.314 \text{ kPa} \cdot \text{m}^3/\text{kmol} \cdot \text{K})(323 \text{ K})} = 0.0335 \text{ kmol}$$

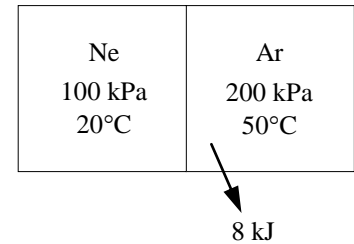

Thus,

$$N_m = N_{\text{Ne}} + N_{\text{Ar}} = 0.0185 \text{ kmol} + 0.0335 \text{ kmol} = 0.0520 \text{ kmol}$$

(a) We take both gases as the system. No work or mass crosses the system boundary, therefore this is a closed system with $W = 0$. Then the conservation of energy equation for this closed system reduces to

$$E_{\text{in}} - E_{\text{out}} = \Delta E_{\text{system}}$$

$$-Q_{\text{out}} = \Delta U = \Delta U_{\text{Ne}} + \Delta U_{\text{Ar}}$$

$$-Q_{\text{out}} = [mc_v(T_m - T_1)]_{\text{Ne}} + [mc_v(T_m - T_1)]_{\text{Ar}}$$

Using c_v values at room temperature and noting that $m = NM$, the final temperature of the mixture is determined to be

$$-8 \text{ kJ} = (0.0185 \times 20.18 \text{ kg})(0.6179 \text{ kJ/kg} \cdot \text{°C})(T_m - 20\text{°C})$$

$$+ (0.0335 \times 39.95 \text{ kg})(0.3122 \text{ kJ/kg} \cdot \text{°C})(T_m - 50\text{°C})$$

$$T_m = \mathbf{27.0\text{°C}} \quad (300.0 \text{ K})$$

(b) The final pressure in the tank is determined from

$$P_m = \frac{N_m R_u T_m}{V_m} = \frac{(0.052 \text{ kmol})(8.314 \text{ kPa} \cdot \text{m}^3/\text{kmol} \cdot \text{K})(300.0 \text{ K})}{0.9 \text{ m}^3} = \mathbf{144.1 \text{ kPa}}$$

13-56 The mass fractions of components of a gas mixture are given. This mixture is enclosed in a rigid, well-insulated vessel, and a paddle wheel in the vessel is turned until specified amount of work have been done on the mixture. The mixture's final pressure and temperature are to be determined.

Assumptions All gases will be modeled as ideal gases with constant specific heats.

Properties The molar masses of N_2 , He, CH_4 , and C_2H_6 are 28.0, 4.0, 16.0, and 30.0 kg/kmol, respectively (Table A-1). The constant-pressure specific heats of these gases at room temperature are 1.039, 5.1926, 2.2537, and 1.7662 kJ/kg·K, respectively (Table A-2a).

Analysis We consider 100 kg of this mixture. The mole numbers of each component are

$$N_{N_2} = \frac{m_{N_2}}{M_{N_2}} = \frac{15 \text{ kg}}{28 \text{ kg/kmol}} = 0.5357 \text{ kmol}$$

$$N_{He} = \frac{m_{He}}{M_{He}} = \frac{5 \text{ kg}}{4 \text{ kg/kmol}} = 1.25 \text{ kmol}$$

$$N_{CH_4} = \frac{m_{CH_4}}{M_{CH_4}} = \frac{60 \text{ kg}}{16 \text{ kg/kmol}} = 3.75 \text{ kmol}$$

$$N_{C_2H_6} = \frac{m_{C_2H_6}}{M_{C_2H_6}} = \frac{20 \text{ kg}}{30 \text{ kg/kmol}} = 0.6667 \text{ kmol}$$

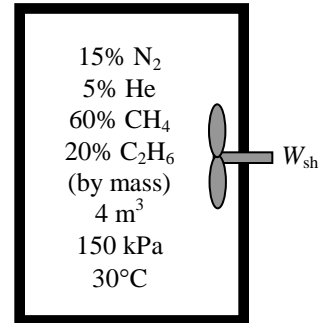

The mole number of the mixture is

$$N_m = N_{N_2} + N_{He} + N_{CH_4} + N_{C_2H_6} = 0.5357 + 1.25 + 3.75 + 0.6667 = 6.2024 \text{ kmol}$$

The apparent molecular weight of the mixture is

$$M_m = \frac{m_m}{N_m} = \frac{100 \text{ kg}}{6.2024 \text{ kmol}} = 16.12 \text{ kg/kmol}$$

The constant-pressure specific heat of the mixture is determined from

$$c_p = mf_{N_2}c_{p,N_2} + mf_{He}c_{p,He} + mf_{CH_4}c_{p,CH_4} + mf_{C_2H_6}c_{p,C_2H_6}$$

$$= 0.15 \times 1.039 + 0.05 \times 5.1926 + 0.60 \times 2.2537 + 0.20 \times 1.7662$$

$$= 2.121 \text{ kJ/kg} \cdot \text{K}$$

The apparent gas constant of the mixture is

$$R = \frac{R_u}{M_m} = \frac{8.134 \text{ kJ/kmol} \cdot \text{K}}{16.12 \text{ kg/kmol}} = 0.5158 \text{ kJ/kg} \cdot \text{K}$$

Then the constant-volume specific heat is

$$c_v = c_p - R = 2.121 - 0.5158 = 1.605 \text{ kJ/kg} \cdot \text{K}$$

The mass in the container is

$$m_m = \frac{P_1 V_m}{RT_1} = \frac{(150 \text{ kPa})(4 \text{ m}^3)}{(0.5158 \text{ kPa} \cdot \text{m}^3/\text{kg} \cdot \text{K})(303 \text{ K})} = 3.840 \text{ kg}$$

An energy balance on the system gives

$$W_{sh,in} = m_m c_v (T_2 - T_1) \longrightarrow T_2 = T_1 + \frac{W_{sh,in}}{m_m c_v} = (303 \text{ K}) + \frac{200 \text{ kJ}}{(3.840 \text{ kg})(1.605 \text{ kJ/kg} \cdot \text{K})} = \mathbf{335.4 \text{ K}}$$

Since the volume remains constant and this is an ideal gas,

$$P_2 = P_1 \frac{T_2}{T_1} = (150 \text{ kPa}) \frac{335.4 \text{ K}}{303 \text{ K}} = \mathbf{166.1 \text{ kPa}}$$

13-57 The states of two gases contained in two tanks are given. The gases are allowed to mix to form a homogeneous mixture. The final pressure, the heat transfer, and the entropy generated are to be determined.

Assumptions 1 Under specified conditions both O_2 and N_2 can be treated as ideal gases, and the mixture as an ideal gas mixture. **2** The tank containing oxygen is insulated. **3** There are no other forms of work involved.

Properties The constant volume specific heats of O_2 and N_2 are $0.658 \text{ kJ/kg}\cdot^\circ\text{C}$ and $0.743 \text{ kJ/kg}\cdot^\circ\text{C}$, respectively. (Table A-2).

Analysis (a) The volume of the O_2 tank and mass of the nitrogen are

$$V_{1,O_2} = \left(\frac{mRT_1}{P_1} \right)_{O_2} = \frac{(1 \text{ kg})(0.2598 \text{ kPa}\cdot\text{m}^3/\text{kg}\cdot\text{K})(288 \text{ K})}{300 \text{ kPa}} = 0.25 \text{ m}^3$$

$$m_{N_2} = \left(\frac{P_1 V_1}{RT_1} \right)_{N_2} = \frac{(500 \text{ kPa})(2 \text{ m}^3)}{(0.2968 \text{ kPa}\cdot\text{m}^3/\text{kg}\cdot\text{K})(323 \text{ K})} = 10.43 \text{ kg}$$

$$V_{\text{total}} = V_{1,O_2} + V_{1,N_2} = 0.25 \text{ m}^3 + 2.0 \text{ m}^3 = 2.25 \text{ m}^3$$

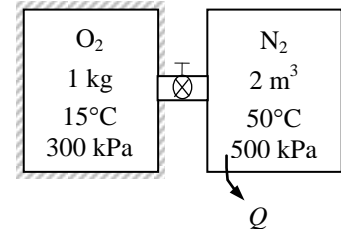

Also,

$$m_{O_2} = 1 \text{ kg} \longrightarrow N_{O_2} = \frac{m_{O_2}}{M_{O_2}} = \frac{1 \text{ kg}}{32 \text{ kg/kmol}} = 0.03125 \text{ kmol}$$

$$m_{N_2} = 10.43 \text{ kg} \longrightarrow N_{N_2} = \frac{m_{N_2}}{M_{N_2}} = \frac{10.43 \text{ kg}}{28 \text{ kg/kmol}} = 0.3725 \text{ kmol}$$

$$N_m = N_{N_2} + N_{O_2} = 0.3725 \text{ kmol} + 0.03125 \text{ kmol} = 0.40375 \text{ kmol}$$

Thus,

$$P_m = \left(\frac{NR_u T}{V} \right)_m = \frac{(0.40375 \text{ kmol})(8.314 \text{ kPa}\cdot\text{m}^3/\text{kmol}\cdot\text{K})(298 \text{ K})}{2.25 \text{ m}^3} = \mathbf{444.6 \text{ kPa}}$$

(b) We take both gases as the system. No work or mass crosses the system boundary, and thus this is a closed system with $W = 0$. Taking the direction of heat transfer to be from the system (will be verified), the energy balance for this closed system reduces to

$$E_{\text{in}} - E_{\text{out}} = \Delta E_{\text{system}}$$

$$-Q_{\text{out}} = \Delta U = \Delta U_{O_2} + \Delta U_{N_2} \longrightarrow Q_{\text{out}} = [mc_v(T_1 - T_m)]_{O_2} + [mc_v(T_1 - T_m)]_{N_2}$$

Using c_v values at room temperature (Table A-2), the heat transfer is determined to be

$$Q_{\text{out}} = (1 \text{ kg})(0.658 \text{ kJ/kg}\cdot^\circ\text{C})(15 - 25)^\circ\text{C} + (10.43 \text{ kg})(0.743 \text{ kJ/kg}\cdot^\circ\text{C})(50 - 25)^\circ\text{C}$$

$$= \mathbf{187.2 \text{ kJ}} \quad (\text{from the system})$$

(c) For an *extended system* that involves the tanks and their immediate surroundings such that the boundary temperature is the surroundings temperature, the entropy balance can be expressed as

$$S_{\text{in}} - S_{\text{out}} + S_{\text{gen}} = \Delta S_{\text{system}}$$

$$-\frac{Q_{\text{out}}}{T_{b,\text{sur}}} + S_{\text{gen}} = m(s_2 - s_1)$$

$$S_{\text{gen}} = m(s_2 - s_1) + \frac{Q_{\text{out}}}{T_{\text{sur}}}$$

The mole fraction of each gas is

$$y_{\text{O}_2} = \frac{N_{\text{O}_2}}{N_m} = \frac{0.03125}{0.40375} = 0.077$$

$$y_{\text{N}_2} = \frac{N_{\text{N}_2}}{N_m} = \frac{0.3725}{0.40375} = 0.923$$

Thus,

$$\begin{aligned} (s_2 - s_1)_{\text{O}_2} &= \left(c_p \ln \frac{T_2}{T_1} - R \ln \frac{y P_{m,2}}{P_1} \right)_{\text{O}_2} \\ &= (0.918 \text{ kJ/kg} \cdot \text{K}) \ln \frac{298 \text{ K}}{288 \text{ K}} - (0.2598 \text{ kJ/kg} \cdot \text{K}) \ln \frac{(0.077)(444.6 \text{ kPa})}{300 \text{ kPa}} \\ &= 0.5952 \text{ kJ/kg} \cdot \text{K} \end{aligned}$$

$$\begin{aligned} (s_2 - s_1)_{\text{N}_2} &= \left(c_p \ln \frac{T_2}{T_1} - R \ln \frac{y P_{m,2}}{P_1} \right)_{\text{N}_2} \\ &= (1.039 \text{ kJ/kg} \cdot \text{K}) \ln \frac{298 \text{ K}}{323 \text{ K}} - (0.2968 \text{ kJ/kg} \cdot \text{K}) \ln \frac{(0.923)(444.6 \text{ kPa})}{500 \text{ kPa}} \\ &= -0.0251 \text{ kJ/kg} \cdot \text{K} \end{aligned}$$

Substituting,

$$S_{\text{gen}} = (1 \text{ kg})(0.5952 \text{ kJ/kg} \cdot \text{K}) + (10.43 \text{ kg})(-0.0251 \text{ kJ/kg} \cdot \text{K}) + \frac{187.2 \text{ kJ}}{298 \text{ K}} = \mathbf{0.962 \text{ kJ/K}}$$



13-58 Problem 13-57 is reconsidered. The results obtained assuming ideal gas behavior with constant specific heats at the average temperature, and using real gas data obtained from EES by assuming variable specific heats over the temperature range are to be compared.

Analysis The problem is solved using EES, and the solution is given below.

"Input Data:"

```
T_O2[1]=15 [C];          T_N2[1]=50 [C]
T[2]=25 [C];           T_o = 25 [C]
m_O2 = 1 [kg];         P_O2[1]=300 [kPa]
V_N2[1]=2 [m^3];      P_N2[1]=500 [kPa]
R_u=8.314 [kJ/kmol-K]; MM_O2=molarmass(O2)
MM_N2=molarmass(N2);  P_O2[1]*V_O2[1]=m_O2*R_u/MM_O2*(T_O2[1]+273)
P_N2[1]*V_N2[1]=m_N2*R_u/MM_N2*(T_N2[1]+273)
V_total=V_O2[1]+V_N2[1]; N_O2=m_O2/MM_O2
N_N2=m_N2/MM_N2;      N_total=N_O2+N_N2
P[2]*V_total=N_total*R_u*(T[2]+273); P_Final =P[2]
```

"Conservation of energy for the combined system:"

```
E_in - E_out = DELTAE_sys
E_in = 0 [kJ]
E_out = Q
DELTAE_sys=m_O2*(intenergy(O2,T=T[2]) - intenergy(O2,T=T_O2[1])) + m_N2*(intenergy(N2,T=T[2]) -
intenergy(N2,T=T_N2[1]))
P_O2[2]=P[2]*N_O2/N_total
P_N2[2]=P[2]*N_N2/N_total
```

"Entropy generation:"

```
- Q/(T_o+273) + S_gen = DELTAS_O2 + DELTAS_N2
DELTAS_O2 = m_O2*(entropy(O2,T=T[2],P=P_O2[2]) - entropy(O2,T=T_O2[1],P=P_O2[1]))
DELTAS_N2 = m_N2*(entropy(N2,T=T[2],P=P_N2[2]) - entropy(N2,T=T_N2[1],P=P_N2[1]))
```

"Constant Property (ConstP) Solution:"

```
-Q_ConstP=m_O2*Cv_O2*(T[2]-T_O2[1])+m_N2*Cv_N2*(T[2]-T_N2[1])
Tav_O2 =(T[2]+T_O2[1])/2
Cv_O2 = SPECHEAT(O2,T=Tav_O2) - R_u/MM_O2
Tav_N2 =(T[2]+T_N2[1])/2
Cv_N2 = SPECHEAT(N2,T=Tav_N2) - R_u/MM_N2
- Q_ConstP/(T_o+273) + S_gen_ConstP = DELTAS_O2_ConstP + DELTAS_N2_ConstP
DELTAS_O2_ConstP = m_O2*( SPECHEAT(O2,T=Tav_O2)*LN((T[2]+273)/(T_O2[1]+273))-
R_u/MM_O2*LN(P_O2[2]/P_O2[1]))
DELTAS_N2_ConstP = m_N2*( SPECHEAT(N2,T=Tav_N2)*LN((T[2]+273)/(T_N2[1]+273))-
R_u/MM_N2*LN(P_N2[2]/P_N2[1]))
```

SOLUTION

Cv_N2=0.7454 [kJ/kg-K]	Cv_O2=0.6627 [kJ/kg-K]	DELTAE_sys=-187.7 [kJ]
DELTAS_N2=-0.262 [kJ/K]	DELTAS_N2_ConstP=-0.2625 [kJ/K]	
DELTAS_O2=0.594 [kJ/K]	DELTAS_O2_ConstP=0.594 [kJ/K]	
E_in=0 [kJ]	E_out=187.7 [kJ]	
MM_N2=28.01 [kg/kmol]	MM_O2=32 [kg/kmol]	m_N2=10.43 [kg]
m_O2=1 [kg]	N_N2=0.3724 [kmol]	N_O2=0.03125 [kmol]
N_total=0.4036 [kmol]	P[2]=444.6 [kPa]	P_Final=444.6 [kPa]
P_N2[1]=500 [kPa]	P_N2[2]=410.1 [kPa]	P_O2[1]=300 [kPa]
P_O2[2]=34.42 [kPa]	Q=187.7 [kJ]	Q_ConstP=187.8 [kJ]
R_u=8.314 [kJ/kmol-K]	S_gen=0.962 [kJ]	S_gen_ConstP=0.9616 [kJ]
Tav_N2=37.5 [C]	Tav_O2=20 [C]	T[2]=25 [C]
T_N2[1]=50 [C]	T_o=25 [C]	T_O2[1]=15 [C]
V_N2[1]=2 [m^3]	V_O2[1]=0.2494 [m^3]	V_total=2.249 [m^3/kg]

13-59 The mass fractions of components of a gas mixture are given. This mixture is compressed in a reversible, isothermal, steady-flow compressor. The work and heat transfer for this compression per unit mass of the mixture are to be determined.

Assumptions All gases will be modeled as ideal gases with constant specific heats.

Properties The molar masses of CH_4 , C_3H_8 , and C_4H_{10} are 16.0, 44.0, and 58.0 kg/kmol, respectively (Table A-1).

Analysis The mole numbers of each component are

$$N_{\text{CH}_4} = \frac{m_{\text{CH}_4}}{M_{\text{CH}_4}} = \frac{60 \text{ kg}}{16 \text{ kg/kmol}} = 3.75 \text{ kmol}$$

$$N_{\text{C}_3\text{H}_8} = \frac{m_{\text{C}_3\text{H}_8}}{M_{\text{C}_3\text{H}_8}} = \frac{25 \text{ kg}}{44 \text{ kg/kmol}} = 0.5682 \text{ kmol}$$

$$N_{\text{C}_4\text{H}_{10}} = \frac{m_{\text{C}_4\text{H}_{10}}}{M_{\text{C}_4\text{H}_{10}}} = \frac{15 \text{ kg}}{58 \text{ kg/kmol}} = 0.2586 \text{ kmol}$$

The mole number of the mixture is

$$N_m = N_{\text{CH}_4} + N_{\text{C}_3\text{H}_8} + N_{\text{C}_4\text{H}_{10}}$$

$$= 3.75 + 0.5682 + 0.2586 = 4.5768 \text{ kmol}$$

The apparent molecular weight of the mixture is

$$M_m = \frac{m_m}{N_m} = \frac{100 \text{ kg}}{4.5768 \text{ kmol}} = 21.85 \text{ kg/kmol}$$

The apparent gas constant of the mixture is

$$R = \frac{R_u}{M_m} = \frac{8.314 \text{ kJ/kmol} \cdot \text{K}}{21.85 \text{ kg/kmol}} = 0.3805 \text{ kJ/kg} \cdot \text{K}$$

For a reversible, isothermal process, the work input is

$$w_{\text{in}} = RT \ln\left(\frac{P_2}{P_1}\right) = (0.3805 \text{ kJ/kg} \cdot \text{K})(293 \text{ K}) \ln\left(\frac{1000 \text{ kPa}}{100 \text{ kPa}}\right) = \mathbf{257 \text{ kJ/kg}}$$

An energy balance on the control volume gives

$$\underbrace{\dot{E}_{\text{in}} - \dot{E}_{\text{out}}}_{\text{Rate of net energy transfer by heat, work, and mass}} = \underbrace{\Delta \dot{E}_{\text{system}}}_{\text{Rate of change in internal, kinetic, potential, etc. energies}} \stackrel{\text{no (steady)}}{=} 0$$

$$\dot{E}_{\text{in}} = \dot{E}_{\text{out}}$$

$$\dot{m}h_1 + \dot{W}_{\text{in}} = \dot{m}h_2 + \dot{Q}_{\text{out}}$$

$$\dot{W}_{\text{in}} - \dot{Q}_{\text{out}} = \dot{m}(h_2 - h_1)$$

$$w_{\text{in}} - q_{\text{out}} = c_p(T_2 - T_1) = 0 \quad \text{since } T_2 = T_1$$

$$w_{\text{in}} = q_{\text{out}}$$

That is,

$$q_{\text{out}} = w_{\text{in}} = \mathbf{257 \text{ kJ/kg}}$$

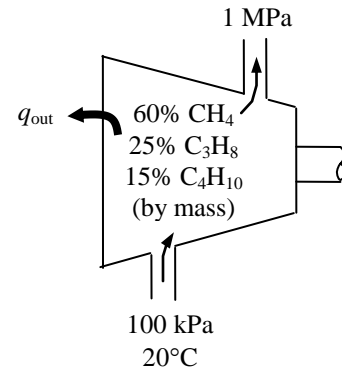

13-60 An equimolar mixture of helium and argon gases expands in a turbine. The isentropic work output of the turbine is to be determined.

Assumptions **1** Under specified conditions both He and Ar can be treated as ideal gases, and the mixture as an ideal gas mixture. **2** The turbine is insulated and thus there is no heat transfer. **3** This is a steady-flow process. **4** The kinetic and potential energy changes are negligible.

Properties The molar masses and specific heats of He and Ar are 4.0 kg/kmol, 40.0 kg/kmol, 5.1926 kJ/kg·°C, and 0.5203 kJ/kg·°C, respectively. (Table A-1 and Table A-2).

Analysis The C_p and k values of this equimolar mixture are determined from

$$M_m = \sum y_i M_i = y_{\text{He}} M_{\text{He}} + y_{\text{Ar}} M_{\text{Ar}} = 0.5 \times 4 + 0.5 \times 40 = 22 \text{ kg/kmol}$$

$$\text{mf}_i = \frac{m_i}{m_m} = \frac{N_i M_i}{N_m M_m} = \frac{y_i M_i}{M_m}$$

$$\begin{aligned} c_{p,m} &= \sum \text{mf}_i c_{p,i} = \frac{y_{\text{He}} M_{\text{He}}}{M_m} c_{p,\text{He}} + \frac{y_{\text{Ar}} M_{\text{Ar}}}{M_m} c_{p,\text{Ar}} \\ &= \frac{0.5 \times 4 \text{ kg/kmol}}{22 \text{ kg/kmol}} (5.1926 \text{ kJ/kg} \cdot \text{K}) + \frac{0.5 \times 40 \text{ kg/kmol}}{22 \text{ kg/kmol}} (0.5203 \text{ kJ/kg} \cdot \text{K}) \\ &= 0.945 \text{ kJ/kg} \cdot \text{K} \end{aligned}$$

and

$$k_m = 1.667 \quad \text{since } k = 1.667 \text{ for both gases.}$$

Therefore, the He-Ar mixture can be treated as a single ideal gas with the properties above. For isentropic processes,

$$T_2 = T_1 \left(\frac{P_2}{P_1} \right)^{(k-1)/k} = (1300 \text{ K}) \left(\frac{200 \text{ kPa}}{2500 \text{ kPa}} \right)^{0.667/1.667} = 473.2 \text{ K}$$

From an energy balance on the turbine,

$$\begin{aligned} \dot{E}_{\text{in}} - \dot{E}_{\text{out}} &= \Delta \dot{E}_{\text{system}} \stackrel{\phi=0(\text{steady})}{=} 0 \\ \dot{E}_{\text{in}} &= \dot{E}_{\text{out}} \\ h_1 &= h_2 + w_{\text{out}} \\ w_{\text{out}} &= h_1 - h_2 \\ w_{\text{out}} &= c_p (T_1 - T_2) = (0.945 \text{ kJ/kg} \cdot \text{K})(1300 - 473.2) \text{ K} = \mathbf{781.3 \text{ kJ/kg}} \end{aligned}$$

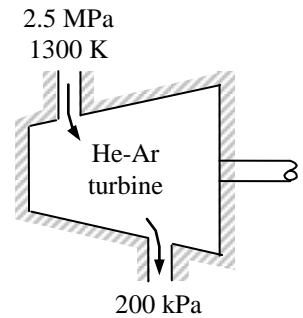

13-61E The volume fractions of components of a gas mixture passing through the turbine of a simple ideal Brayton cycle are given. The thermal efficiency of this cycle is to be determined.

Assumptions All gases will be modeled as ideal gases with constant specific heats.

Properties The molar masses of N_2 , O_2 , H_2O , and CO_2 are 28.0, 32.0, 18.0, and 44.0 lbm/lbmol, respectively (Table A-1E). The constant-pressure specific heats of these gases at room temperature are 0.248, 0.219, 0.445, and 0.203 Btu/lbm·R, respectively. The air properties at room temperature are $c_p = 0.240$ Btu/lbm·R, $c_v = 0.171$ Btu/lbm·R, $k = 1.4$ (Table A-2Ea).

Analysis We consider 100 lbmol of this mixture. Noting that volume fractions are equal to the mole fractions, mass of each component are

$$\begin{aligned} m_{N_2} &= N_{N_2} M_{N_2} = (20 \text{ lbmol})(28 \text{ lbm/lbmol}) = 560 \text{ lbm} \\ m_{O_2} &= N_{O_2} M_{O_2} = (5 \text{ lbmol})(32 \text{ lbm/lbmol}) = 160 \text{ lbm} \\ m_{H_2O} &= N_{H_2O} M_{H_2O} = (35 \text{ lbmol})(18 \text{ lbm/lbmol}) = 630 \text{ lbm} \\ m_{CO_2} &= N_{CO_2} M_{CO_2} = (40 \text{ lbmol})(44 \text{ lbm/lbmol}) = 1760 \text{ lbm} \end{aligned}$$

The total mass is

$$\begin{aligned} m_m &= m_{N_2} + m_{O_2} + m_{H_2O} + m_{CO_2} \\ &= 560 + 160 + 630 + 1760 \\ &= 3110 \text{ lbm} \end{aligned}$$

Then the mass fractions are

$$\begin{aligned} mf_{N_2} &= \frac{m_{N_2}}{m_m} = \frac{560 \text{ lbm}}{3110 \text{ lbm}} = 0.1801 \\ mf_{O_2} &= \frac{m_{O_2}}{m_m} = \frac{160 \text{ lbm}}{3110 \text{ lbm}} = 0.05145 \\ mf_{H_2O} &= \frac{m_{H_2O}}{m_m} = \frac{630 \text{ lbm}}{3110 \text{ lbm}} = 0.2026 \\ mf_{CO_2} &= \frac{m_{CO_2}}{m_m} = \frac{1760 \text{ lbm}}{3110 \text{ lbm}} = 0.5659 \end{aligned}$$

The constant-pressure specific heat of the mixture is determined from

$$\begin{aligned} c_p &= mf_{N_2} c_{p,N_2} + mf_{O_2} c_{p,O_2} + mf_{H_2O} c_{p,H_2O} + mf_{CO_2} c_{p,CO_2} \\ &= 0.1801 \times 0.248 + 0.05145 \times 0.219 + 0.2026 \times 0.445 + 0.5659 \times 0.203 \\ &= 0.2610 \text{ Btu/lbm} \cdot \text{R} \end{aligned}$$

The apparent molecular weight of the mixture is

$$M_m = \frac{m_m}{N_m} = \frac{3110 \text{ lbm}}{100 \text{ lbmol}} = 31.10 \text{ lbm/lbmol}$$

The apparent gas constant of the mixture is

$$R = \frac{R_u}{M_m} = \frac{1.9858 \text{ Btu/lbmol} \cdot \text{R}}{31.10 \text{ lbm/lbmol}} = 0.06385 \text{ Btu/lbm} \cdot \text{R}$$

Then the constant-volume specific heat is

$$c_v = c_p - R = 0.2610 - 0.06385 = 0.1971 \text{ Btu/lbm} \cdot \text{R}$$

The specific heat ratio is

$$k = \frac{c_p}{c_v} = \frac{0.2610}{0.1971} = 1.324$$

The average of the air properties at room temperature and combustion gas properties are

20% N_2 , 5% O_2
35% H_2O , 40% CO_2
(by volume)

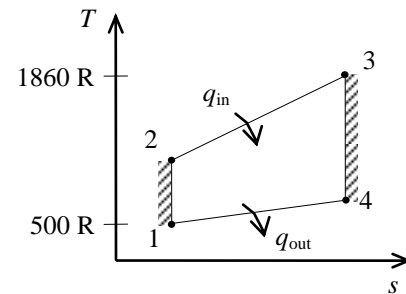
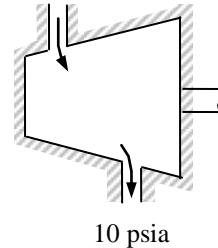

$$c_{p,\text{avg}} = 0.5(0.2610 + 0.240) = 0.2505 \text{ Btu/lbm} \cdot \text{R}$$

$$c_{v,\text{avg}} = 0.5(0.1971 + 0.171) = 0.1841 \text{ Btu/lbm} \cdot \text{R}$$

$$k_{\text{avg}} = 0.5(1.324 + 1.4) = 1.362$$

These average properties will be used for heat addition and rejection processes. For compression, the air properties at room temperature and during expansion, the mixture properties will be used. During the compression process,

$$T_2 = T_1 \left(\frac{P_2}{P_1} \right)^{(k-1)/k} = (500 \text{ R})(6)^{0.4/1.4} = 834.3 \text{ R}$$

During the heat addition process,

$$q_{\text{in}} = c_{p,\text{avg}}(T_3 - T_2) = (0.2505 \text{ Btu/lbm} \cdot \text{R})(1860 - 834.3) \text{ R} = 256.9 \text{ Btu/lbm}$$

During the expansion process,

$$T_4 = T_3 \left(\frac{P_4}{P_3} \right)^{(k-1)/k} = (1860 \text{ R}) \left(\frac{1}{6} \right)^{0.362/1.362} = 1155.3 \text{ R}$$

During the heat rejection process,

$$q_{\text{out}} = c_{p,\text{avg}}(T_4 - T_1) = (0.2505 \text{ Btu/lbm} \cdot \text{R})(1155.3 - 500) \text{ R} = 164.2 \text{ Btu/lbm}$$

The thermal efficiency of the cycle is then

$$\eta_{\text{th}} = 1 - \frac{q_{\text{out}}}{q_{\text{in}}} = 1 - \frac{164.2 \text{ Btu/lbm}}{256.9 \text{ Btu/lbm}} = 0.361 = \mathbf{36.1\%}$$

13-62E The thermal efficiency of the cycle in the previous problem is to be compared to that predicted by air standard analysis?

Assumptions Air-standard assumptions are applicable.

Properties The air properties at room temperature are $c_p = 0.240$ Btu/lbm·R, $c_v = 0.171$ Btu/lbm·R, $k = 1.4$ (Table A-2Ea).

Analysis In the previous problem, the thermal efficiency of the cycle was determined to be **0.361** (36.1%). The thermal efficiency with air-standard model is determined from

$$\eta_{\text{th}} = 1 - \frac{1}{r_p^{(k-1)/k}} = 1 - \frac{1}{6^{0.4/1.4}} = 0.401 = \mathbf{40.1\%}$$

which is greater than that calculated with gas mixture analysis in the previous problem.

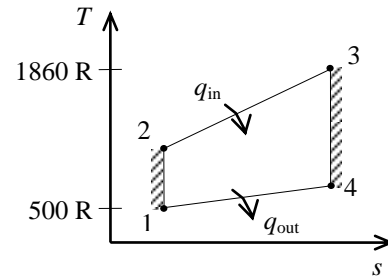

13-63E The mass fractions of a natural gas mixture at a specified pressure and temperature trapped in a geological location are given. This natural gas is pumped to the surface. The work required is to be determined using Kay's rule and the enthalpy-departure method.

Properties The molar masses of CH_4 and C_2H_6 are 16.0 and 30.0 lbm/lbmol, respectively. The critical properties are 343.9 R, 673 psia for CH_4 and 549.8 R and 708 psia for C_2H_6 (Table A-1E). The constant-pressure specific heats of these gases at room temperature are 0.532 and 0.427 Btu/lbm·R, respectively (Table A-2Ea).

Analysis We consider 100 lbm of this mixture. Then the mole numbers of each component are

$$N_{\text{CH}_4} = \frac{m_{\text{CH}_4}}{M_{\text{CH}_4}} = \frac{75 \text{ lbm}}{16 \text{ lbm/lbmol}} = 4.6875 \text{ lbmol}$$

$$N_{\text{C}_2\text{H}_6} = \frac{m_{\text{C}_2\text{H}_6}}{M_{\text{C}_2\text{H}_6}} = \frac{25 \text{ lbm}}{30 \text{ lbm/lbmol}} = 0.8333 \text{ lbmol}$$

The mole number of the mixture and the mole fractions are

$$N_m = 4.6875 + 0.8333 = 5.5208 \text{ lbmol}$$

$$y_{\text{CH}_4} = \frac{N_{\text{CH}_4}}{N_m} = \frac{4.6875 \text{ lbmol}}{5.5208 \text{ lbmol}} = 0.8491$$

$$y_{\text{C}_2\text{H}_6} = \frac{N_{\text{C}_2\text{H}_6}}{N_m} = \frac{0.8333 \text{ lbmol}}{5.5208 \text{ lbmol}} = 0.1509$$

<p>75% CH_4 25% C_2H_6 (by mass) 1300 psia 300°F</p>

Then the apparent molecular weight of the mixture becomes

$$M_m = \frac{m_m}{N_m} = \frac{100 \text{ lbm}}{5.5208 \text{ lbmol}} = 18.11 \text{ lbm/lbmol}$$

The apparent gas constant of the mixture is

$$R = \frac{R_u}{M_m} = \frac{1.9858 \text{ Btu/lbmol} \cdot \text{R}}{18.11 \text{ lbm/lbmol}} = 0.1097 \text{ Btu/lbm} \cdot \text{R}$$

The constant-pressure specific heat of the mixture is determined from

$$c_p = \text{mf}_{\text{CH}_4} c_{p,\text{CH}_4} + \text{mf}_{\text{C}_2\text{H}_6} c_{p,\text{C}_2\text{H}_6} = 0.75 \times 0.532 + 0.25 \times 0.427 = 0.506 \text{ Btu/lbm} \cdot \text{R}$$

To use Kay's rule, we need to determine the pseudo-critical temperature and pseudo-critical pressure of the mixture using the critical point properties of gases.

$$\begin{aligned} T'_{\text{cr},m} &= \sum y_i T_{\text{cr},i} = y_{\text{CH}_4} T_{\text{cr},\text{CH}_4} + y_{\text{C}_2\text{H}_6} T_{\text{cr},\text{C}_2\text{H}_6} \\ &= (0.8491)(343.9 \text{ R}) + (0.1509)(549.8 \text{ R}) \\ &= 375.0 \text{ R} \end{aligned}$$

$$\begin{aligned} P'_{\text{cr},m} &= \sum y_i P_{\text{cr},i} = y_{\text{CH}_4} P_{\text{cr},\text{CH}_4} + y_{\text{C}_2\text{H}_6} P_{\text{cr},\text{C}_2\text{H}_6} \\ &= (0.8491)(673 \text{ psia}) + (0.1509)(708 \text{ psia}) \\ &= 678.3 \text{ psia} \end{aligned}$$

The compressibility factor of the gas mixture in the reservoir and the mass of this gas are

$$\left. \begin{aligned} T_R &= \frac{T_m}{T'_{\text{cr},m}} = \frac{760 \text{ R}}{375.0 \text{ R}} = 2.027 \\ P_R &= \frac{P_m}{P'_{\text{cr},m}} = \frac{1300 \text{ psia}}{678.3 \text{ psia}} = 1.917 \end{aligned} \right\} Z_m = 0.963 \quad (\text{Fig. A-15 or EES, we used EES.})$$

$$m = \frac{P\mathcal{V}}{Z_m RT} = \frac{(1300 \text{ psia})(2 \times 10^6 \text{ ft}^3)}{(0.963)(0.5925 \text{ psia} \cdot \text{ft}^3/\text{lbm} \cdot \text{R})(760 \text{ R})} = 5.996 \times 10^6 \text{ lbm}$$

The enthalpy departure factors in the reservoir and the surface are (from EES or Fig. A-29, we used EES.)

$$\left. \begin{aligned} T_{R1} &= \frac{T_m}{T_{cr,m}} = \frac{760 \text{ R}}{375.0 \text{ R}} = 2.027 \\ P_{R1} &= \frac{P_m}{P_{cr,m}} = \frac{1300 \text{ psia}}{678.3 \text{ psia}} = 1.917 \end{aligned} \right\} Z_{h1} = 0.487$$

$$\left. \begin{aligned} T_{R2} &= \frac{T_m}{T_{cr,m}} = \frac{660 \text{ R}}{375.0 \text{ R}} = 1.76 \\ P_{R2} &= \frac{P_m}{P_{cr,m}} = \frac{20 \text{ psia}}{678.3 \text{ psia}} = 0.0295 \end{aligned} \right\} Z_{h2} = 0.0112$$

The enthalpy change for the ideal gas mixture is

$$(h_1 - h_2)_{\text{ideal}} = c_p(T_1 - T_2) = (0.506 \text{ Btu/lbm} \cdot \text{R})(760 - 660)\text{R} = 50.6 \text{ Btu/lbm}$$

The enthalpy change with departure factors is

$$\begin{aligned} h_1 - h_2 &= (h_1 - h_2)_{\text{ideal}} - RT'_{cr,m}(Z_{h1} - Z_{h2}) \\ &= 50.6 - (0.1096)(375)(0.487 - 0.0112) \\ &= 31.02 \text{ Btu/lbm} \end{aligned}$$

The work input is then

$$W_{\text{in}} = m(h_1 - h_2) = (5.996 \times 10^6 \text{ lbm})(31.02 \text{ Btu/lbm}) = \mathbf{1.86 \times 10^8 \text{ Btu}}$$

13-64E  A gas mixture with known mass fractions is accelerated through a nozzle from a specified state to a specified pressure. For a specified isentropic efficiency, the exit temperature and the exit velocity of the mixture are to be determined.

Assumptions 1 Under specified conditions both N_2 and CO_2 can be treated as ideal gases, and the mixture as an ideal gas mixture. **2** The nozzle is adiabatic and thus heat transfer is negligible. **3** This is a steady-flow process. **4** Potential energy changes are negligible.

Properties The specific heats of N_2 and CO_2 are $c_{p,N_2} = 0.248$ Btu/lbm·R, $c_{v,N_2} = 0.177$ Btu/lbm·R, $c_{p,CO_2} = 0.203$ Btu/lbm·R, and $c_{v,CO_2} = 0.158$ Btu/lbm·R. (Table A-2E).

Analysis (a) Under specified conditions both N_2 and CO_2 can be treated as ideal gases, and the mixture as an ideal gas mixture. The c_p , c_v , and k values of this mixture are determined from

$$\begin{aligned} c_{p,m} &= \sum mf_i c_{p,i} = mf_{N_2} c_{p,N_2} + mf_{CO_2} c_{p,CO_2} \\ &= (0.65)(0.248) + (0.35)(0.203) \\ &= 0.2323 \text{ Btu/lbm}\cdot\text{R} \end{aligned}$$

$$\begin{aligned} c_{v,m} &= \sum mf_i c_{v,i} = mf_{N_2} c_{v,N_2} + mf_{CO_2} c_{v,CO_2} \\ &= (0.65)(0.177) + (0.35)(0.158) \\ &= 0.1704 \text{ Btu/lbm}\cdot\text{R} \end{aligned}$$

$$k_m = \frac{c_{p,m}}{c_{v,m}} = \frac{0.2323 \text{ Btu/lbm}\cdot\text{R}}{0.1704 \text{ Btu/lbm}\cdot\text{R}} = 1.363$$

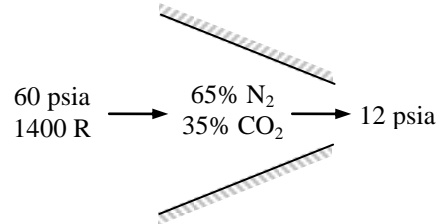

Therefore, the N_2 - CO_2 mixture can be treated as a single ideal gas with above properties. Then the isentropic exit temperature can be determined from

$$T_{2s} = T_1 \left(\frac{P_2}{P_1} \right)^{(k-1)/k} = (1400 \text{ R}) \left(\frac{12 \text{ psia}}{60 \text{ psia}} \right)^{0.363/1.363} = 911.7 \text{ R}$$

From the definition of isentropic efficiency,

$$\eta_N = \frac{h_1 - h_2}{h_1 - h_{2s}} = \frac{c_p(T_1 - T_2)}{c_p(T_1 - T_{2s})} \longrightarrow 0.88 = \frac{1400 - T_2}{1400 - 911.7} \longrightarrow T_2 = \mathbf{970.3 \text{ R}}$$

(b) Noting that, $q = w = 0$, from the steady-flow energy balance relation,

$$\begin{aligned} \dot{E}_{in} - \dot{E}_{out} &= \Delta \dot{E}_{system} \stackrel{\phi^0(\text{steady})}{=} 0 \\ \dot{E}_{in} &= \dot{E}_{out} \end{aligned}$$

$$h_1 + V_1^2 / 2 = h_2 + V_2^2 / 2$$

$$0 = c_p(T_2 - T_1) + \frac{V_2^2 - V_1^2}{2} \stackrel{\phi^0}{}$$

$$V_2 = \sqrt{2c_p(T_1 - T_2)} = \sqrt{2(0.2323 \text{ Btu/lbm}\cdot\text{R})(1400 - 970.3) \text{ R} \left(\frac{25,037 \text{ ft}^2/\text{s}^2}{1 \text{ Btu/lbm}} \right)} = \mathbf{2236 \text{ ft/s}}$$



13-65E Problem 13-64E is reconsidered. The problem is first to be solved and then, for all other conditions being the same, the problem is to be resolved to determine the composition of the nitrogen and carbon dioxide that is required to have an exit velocity of 2200 ft/s at the nozzle exit.

Analysis The problem is solved using EES, and the solution is given below.

"Given"

mf_N2=0.65
 mf_CO2=1-mf_N2
 P1=60 [psia]
 T1=1400 [R]
 Vel1=0 [ft/s]
 P2=12 [psia]
 eta_N=0.88
 "Vel2=2200 [ft/s]"

"Properties"

c_p_N2=0.248 [Btu/lbm-R]
 c_v_N2=0.177 [Btu/lbm-R]
 c_p_CO2=0.203 [Btu/lbm-R]
 c_v_CO2=0.158 [Btu/lbm-R]
 MM_N2=28 [lbm/lbmol]
 MM_CO2=44 [lbm/lbmol]

"Analysis"

c_p_m=mf_N2*c_p_N2+mf_CO2*c_p_CO2
 c_v_m=mf_N2*c_v_N2+mf_CO2*c_v_CO2
 k_m=c_p_m/c_v_m
 T2_s=T1*(P2/P1)^((k_m-1)/k_m)
 eta_N=(T1-T2)/(T1-T2_s)
 0=c_p_m*(T2-T1)+(Vel2^2-Vel1^2)/2*Convert(ft^2/s^2, Btu/lbm)
 N_N2=mf_N2/MM_N2
 N_CO2=mf_CO2/MM_CO2
 N_total=N_N2+N_CO2
 y_N2=N_N2/N_total
 y_CO2=N_CO2/N_total

SOLUTION of the stated problem

c_p_CO2=0.203 [Btu/lbm-R]	c_p_m=0.2323 [Btu/lbm-R]	c_p_N2=0.248 [Btu/lbm-R]
c_v_CO2=0.158 [Btu/lbm-R]	c_v_m=0.1704 [Btu/lbm-R]	c_v_N2=0.177 [Btu/lbm-R]
eta_N=0.88	k_m=1.363	mf_CO2=0.35
mf_N2=0.65	MM_CO2=44 [lbm/lbmol]	MM_N2=28 [lbm/lbmol]
N_CO2=0.007955	N_N2=0.02321	N_total=0.03117
P1=60 [psia]	P2=12 [psia]	T1=1400 [R]
T2=970.3 [R]	T2_s=911.7 [R]	Vel1=0 [ft/s]
Vel2=2236 [ft/s]	y_CO2=0.2552	y_N2=0.7448

SOLUTION of the problem with exit velocity of 2200 ft/s

c_p_CO2=0.203 [Btu/lbm-R]	c_p_m=0.2285 [Btu/lbm-R]	c_p_N2=0.248 [Btu/lbm-R]
c_v_CO2=0.158 [Btu/lbm-R]	c_v_m=0.1688 [Btu/lbm-R]	c_v_N2=0.177 [Btu/lbm-R]
eta_N=0.88	k_m=1.354	mf_CO2=0.434
mf_N2=0.566	MM_CO2=44 [lbm/lbmol]	MM_N2=28 [lbm/lbmol]
N_CO2=0.009863	N_N2=0.02022	N_total=0.03008
P1=60 [psia]	P2=12 [psia]	T1=1400 [R]
T2=976.9 [R]	T2_s=919.3 [R]	Vel1=0 [ft/s]
Vel2=2200 [ft/s]	y_CO2=0.3279	y_N2=0.6721

13-66 A piston-cylinder device contains a gas mixture at a given state. Heat is transferred to the mixture. The amount of heat transfer and the entropy change of the mixture are to be determined.

Assumptions 1 Under specified conditions both H_2 and N_2 can be treated as ideal gases, and the mixture as an ideal gas mixture. **2** Kinetic and potential energy changes are negligible.

Properties The constant pressure specific heats of H_2 and N_2 at 450 K are 14.501 kJ/kg·K and 1.049 kJ/kg·K, respectively. (Table A-2b).

Analysis (a) Noting that $P_2 = P_1$ and $V_2 = 2V_1$,

$$\frac{P_2 V_2}{T_2} = \frac{P_1 V_1}{T_1} \longrightarrow T_2 = \frac{2V_1}{V_1} T_1 = 2T_1 = (2)(300 \text{ K}) = 600 \text{ K}$$

From the closed system energy balance relation,

$$E_{in} - E_{out} = \Delta E_{system}$$

$$Q_{in} - W_{b,out} = \Delta U \rightarrow Q_{in} = \Delta H$$

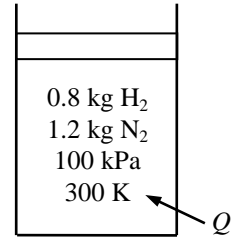

since W_b and ΔU combine into ΔH for quasi-equilibrium constant pressure processes.

$$Q_{in} = \Delta H = \Delta H_{H_2} + \Delta H_{N_2} = [mc_{p,avg}(T_2 - T_1)]_{H_2} + [mc_{p,avg}(T_2 - T_1)]_{N_2}$$

$$= (0.8 \text{ kg})(14.501 \text{ kJ/kg} \cdot \text{K})(600 - 300) \text{ K} + (1.2 \text{ kg})(1.049 \text{ kJ/kg} \cdot \text{K})(600 - 300) \text{ K}$$

$$= \mathbf{3858 \text{ kJ}}$$

(b) Noting that the total mixture pressure, and thus the partial pressure of each gas, remains constant, the entropy change of the mixture during this process is

$$\Delta S_{H_2} = [m(s_2 - s_1)]_{H_2} = m_{H_2} \left(c_p \ln \frac{T_2}{T_1} - R \ln \frac{P_2}{P_1} \right)_{H_2} = m_{H_2} \left(c_p \ln \frac{T_2}{T_1} \right)_{H_2}$$

$$= (0.8 \text{ kg})(14.501 \text{ kJ/kg} \cdot \text{K}) \ln \frac{600 \text{ K}}{300 \text{ K}}$$

$$= 8.041 \text{ kJ/K}$$

$$\Delta S_{N_2} = [m(s_2 - s_1)]_{N_2} = m_{N_2} \left(c_p \ln \frac{T_2}{T_1} - R \ln \frac{P_2}{P_1} \right)_{N_2} = m_{N_2} \left(c_p \ln \frac{T_2}{T_1} \right)_{N_2}$$

$$= (1.2 \text{ kg})(1.049 \text{ kJ/kg} \cdot \text{K}) \ln \frac{600 \text{ K}}{300 \text{ K}}$$

$$= 0.8725 \text{ kJ/K}$$

$$\Delta S_{total} = \Delta S_{H_2} + \Delta S_{N_2} = 8.041 \text{ kJ/K} + 0.8725 \text{ kJ/K} = \mathbf{8.91 \text{ kJ/K}}$$



13-67 The temperatures and pressures of two gases forming a mixture in a mixing chamber are given. The mixture temperature and the rate of entropy generation are to be determined.

Assumptions 1 Under specified conditions both C_2H_6 and CH_4 can be treated as ideal gases, and the mixture as an ideal gas mixture. **2** The mixing chamber is insulated and thus there is no heat transfer. **3** There are no other forms of work involved. **3** This is a steady-flow process. **4** The kinetic and potential energy changes are negligible.

Properties The specific heats of C_2H_6 and CH_4 are $1.7662 \text{ kJ/kg}\cdot^\circ\text{C}$ and $2.2537 \text{ kJ/kg}\cdot^\circ\text{C}$, respectively. (Table A-2b).

Analysis (a) The enthalpy of ideal gases is independent of pressure, and thus the two gases can be treated independently even after mixing. Noting that

$\dot{W} = \dot{Q} = 0$, the steady-flow energy balance equation reduces to

$$\dot{E}_{\text{in}} - \dot{E}_{\text{out}} = \Delta \dot{E}_{\text{system}} \stackrel{\phi=0(\text{steady})}{=} 0$$

$$\dot{E}_{\text{in}} = \dot{E}_{\text{out}}$$

$$\sum \dot{m}_i h_i = \sum \dot{m}_e h_e$$

$$0 = \sum \dot{m}_e h_e - \sum \dot{m}_i h_i = \dot{m}_{C_2H_6} (h_e - h_i)_{C_2H_6} + \dot{m}_{CH_4} (h_e - h_i)_{CH_4}$$

$$0 = [\dot{m} c_p (T_e - T_i)]_{C_2H_6} + [\dot{m} c_p (T_e - T_i)]_{CH_4}$$

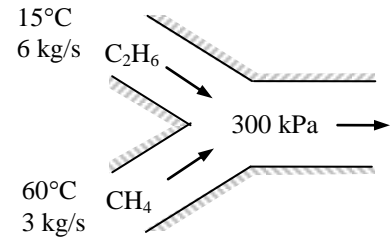

Using c_p values at room temperature and substituting, the exit temperature of the mixture becomes

$$0 = (6 \text{ kg/s})(1.7662 \text{ kJ/kg}\cdot^\circ\text{C})(T_m - 15^\circ\text{C}) + (3 \text{ kg/s})(2.2537 \text{ kJ/kg}\cdot^\circ\text{C})(T_m - 60^\circ\text{C})$$

$$T_m = \mathbf{32.5^\circ\text{C}} \quad (305.5 \text{ K})$$

(b) The rate of entropy change associated with this process is determined from an entropy balance on the mixing chamber,

$$\dot{S}_{\text{in}} - \dot{S}_{\text{out}} + \dot{S}_{\text{gen}} = \Delta \dot{S}_{\text{system}} \stackrel{\approx 0}{=} 0$$

$$[\dot{m}(s_1 - s_2)]_{C_2H_6} + [\dot{m}(s_1 - s_2)]_{CH_4} + \dot{S}_{\text{gen}} = 0$$

$$\dot{S}_{\text{gen}} = [\dot{m}(s_2 - s_1)]_{C_2H_6} + [\dot{m}(s_2 - s_1)]_{CH_4}$$

The molar flow rate of the two gases in the mixture is

$$\dot{N}_{C_2H_6} = \left(\frac{\dot{m}}{M} \right)_{C_2H_6} = \frac{6 \text{ kg/s}}{30 \text{ kg/kmol}} = 0.2 \text{ kmol/s}$$

$$\dot{N}_{CH_4} = \left(\frac{\dot{m}}{M} \right)_{CH_4} = \frac{4.5 \text{ kg/s}}{16 \text{ kg/kmol}} = 0.1875 \text{ kmol/s}$$

Then the mole fraction of each gas becomes

$$y_{C_2H_6} = \frac{0.2}{0.2 + 0.1875} = 0.5161$$

$$y_{CH_4} = \frac{0.1875}{0.2 + 0.1875} = 0.4839$$

Thus,

$$\begin{aligned} (s_2 - s_1)_{C_2H_6} &= \left(c_p \ln \frac{T_2}{T_1} - R \ln \frac{y P_{m,2}}{P_1} \right)_{C_2H_6} = \left(c_p \ln \frac{T_2}{T_1} - R \ln y \right)_{C_2H_6} \\ &= (1.7662 \text{ kJ/kg}\cdot\text{K}) \ln \frac{305.5 \text{ K}}{288 \text{ K}} - (0.2765 \text{ kJ/kg}\cdot\text{K}) \ln(0.5161) = 0.2872 \text{ kJ/kg}\cdot\text{K} \end{aligned}$$

$$\begin{aligned} (s_2 - s_1)_{CH_4} &= \left(c_p \ln \frac{T_2}{T_1} - R \ln \frac{y P_{m,2}}{P_1} \right)_{CH_4} = \left(c_p \ln \frac{T_2}{T_1} - R \ln y \right)_{CH_4} \\ &= (2.2537 \text{ kJ/kg}\cdot\text{K}) \ln \frac{305.5 \text{ K}}{333 \text{ K}} - (0.5182 \text{ kJ/kg}\cdot\text{K}) \ln(0.4839) = 0.1821 \text{ kJ/kg}\cdot\text{K} \end{aligned}$$

Noting that $P_{m,2} = P_{i,1} = 300 \text{ kPa}$ and substituting,

$$\dot{S}_{\text{gen}} = (6 \text{ kg/s})(0.2872 \text{ kJ/kg}\cdot\text{K}) + (3 \text{ kg/s})(0.1821 \text{ kJ/kg}\cdot\text{K}) = \mathbf{2.27 \text{ kW/K}}$$



13-68 Problem 13-67 is reconsidered. The effect of the mass fraction of methane in the mixture on the mixture temperature and the rate of exergy destruction is to be investigated.

Analysis The problem is solved using EES, and the solution is given below.

"Given"

"1: C2H6, 2: CH4"

$m_{\text{dot_total}}=9$ [kg/s]

"mf_CH4=0.3333"

$mf_{\text{C2H6}}=1-mf_{\text{CH4}}$

$m_{\text{dot_1}}=mf_{\text{C2H6}}*m_{\text{dot_total}}$

$m_{\text{dot_2}}=mf_{\text{CH4}}*m_{\text{dot_total}}$

$T1=(15+273)$ [K]

$T2=(60+273)$ [K]

$P=300$ [kPa]

$T0=(25+273)$ [K]

"Properties"

$c_{p_1}=1.7662$ [kJ/kg-K]

$c_{p_2}=2.2537$ [kJ/kg-K]

$R_1=0.2765$ [kJ/kg-K]

$R_2=0.5182$ [kJ/kg-K]

$MM_1=30$ [kg/kmol]

$MM_2=16$ [kg/kmol]

"Analysis"

$0=m_{\text{dot_1}}*c_{p_1}*(T3-T1)+m_{\text{dot_2}}*c_{p_2}*(T3-T2)$

$N_{\text{dot_1}}=m_{\text{dot_1}}/MM_1$

$N_{\text{dot_2}}=m_{\text{dot_2}}/MM_2$

$N_{\text{dot_total}}=N_{\text{dot_1}}+N_{\text{dot_2}}$

$y_1=N_{\text{dot_1}}/N_{\text{dot_total}}$

$y_2=N_{\text{dot_2}}/N_{\text{dot_total}}$

$DELTA s_{\text{1}}=c_{p_1}*\ln(T3/T1)-R_1*\ln(y_1)$

$DELTA s_{\text{2}}=c_{p_2}*\ln(T3/T2)-R_2*\ln(y_2)$

$S_{\text{dot_gen}}=m_{\text{dot_1}}*DELTA s_{\text{1}}+m_{\text{dot_2}}*DELTA s_{\text{2}}$

$X_{\text{dot_dest}}=T0*S_{\text{dot_gen}}$

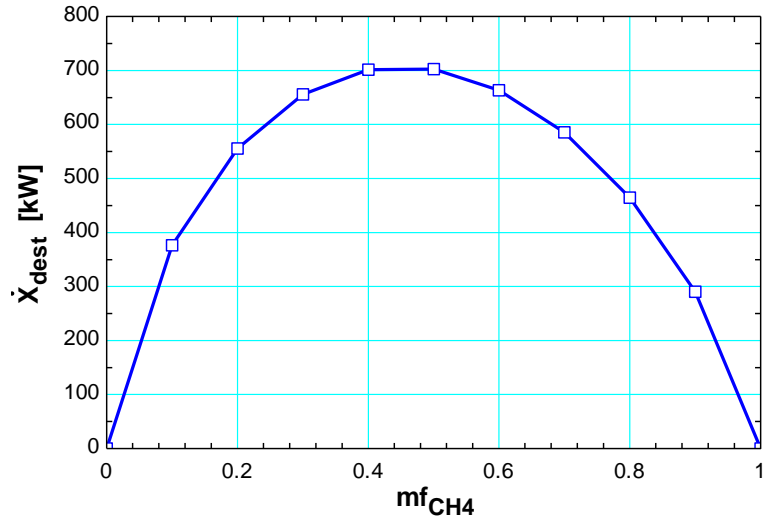

mf _{F2}	T3 [K]	X _{dot_dest} [kW]
0	288	0
0.1	293.6	376.4
0.2	298.9	555.4
0.3	303.9	655.8
0.4	308.7	701.4
0.5	313.2	702.5
0.6	317.6	663.6
0.7	321.7	585.4
0.8	325.6	464.6
0.9	329.4	290.2
1	333	0.09793

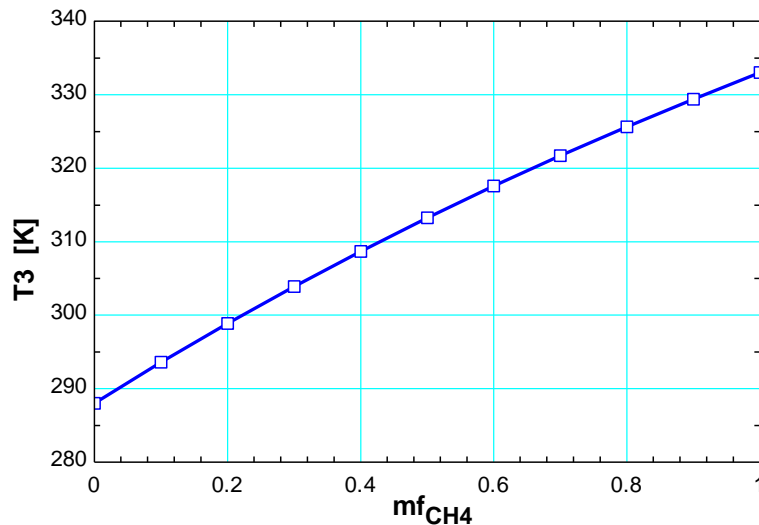

13-69E In an air-liquefaction plant, it is proposed that the pressure and temperature of air be adiabatically reduced. It is to be determined whether this process is possible and the work produced is to be determined using Kay's rule and the departure charts.

Assumptions Air is a gas mixture with 21% O₂ and 79% N₂, by mole.

Properties The molar masses of O₂ and N₂ are 32.0 and 28.0 lbm/lbmol, respectively. The critical properties are 278.6 R, 736 psia for O₂ and 227.1 R and 492 psia for N₂ (Table A-1E).

Analysis To use Kay's rule, we need to determine the pseudo-critical temperature and pseudo-critical pressure of the mixture using the critical point properties of gases.

$$T'_{cr,m} = \sum y_i T_{cr,i} = y_{O_2} T_{cr,O_2} + y_{N_2} T_{cr,N_2}$$

$$= (0.21)(278.6 \text{ R}) + (0.79)(227.1 \text{ R}) = 237.9 \text{ R}$$

$$P'_{cr,m} = \sum y_i P_{cr,i} = y_{O_2} P_{cr,O_2} + y_{N_2} P_{cr,N_2}$$

$$= (0.21)(736 \text{ psia}) + (0.79)(492 \text{ psia}) = 543.2 \text{ psia}$$

21% O₂
79% N₂
(by mole)
1500 psia
40°F

The enthalpy and entropy departure factors at the initial and final states are (from EES)

$$\left. \begin{aligned} T_{R1} &= \frac{T_{m1}}{T'_{cr,m}} = \frac{500 \text{ R}}{237.9 \text{ R}} = 2.102 \\ P_{R1} &= \frac{P_{m1}}{P'_{cr,m}} = \frac{1500 \text{ psia}}{432.2 \text{ psia}} = 3.471 \end{aligned} \right\} \begin{aligned} Z_{h1} &= 0.725 \\ Z_{s1} &= 0.339 \end{aligned}$$

$$\left. \begin{aligned} T_{R2} &= \frac{T_{m2}}{T'_{cr,m}} = \frac{360 \text{ R}}{237.9 \text{ R}} = 1.513 \\ P_{R2} &= \frac{P_{m2}}{P'_{cr,m}} = \frac{15 \text{ psia}}{432.2 \text{ psia}} = 0.0347 \end{aligned} \right\} \begin{aligned} Z_{h2} &= 0.0179 \\ Z_{s2} &= 0.00906 \end{aligned}$$

The enthalpy and entropy changes of the air under the ideal gas assumption is (Properties are from Table A-17E)

$$(h_2 - h_1)_{ideal} = 85.97 - 119.48 = -33.5 \text{ Btu/lbm}$$

$$(s_2 - s_1)_{ideal} = s_2^o - s_1^o - R \ln \frac{P_2}{P_1} = 0.50369 - 0.58233 - (0.06855) \ln \frac{15}{1500} = 0.2370 \text{ Btu/lbm} \cdot \text{R}$$

With departure factors, the enthalpy change (i.e., the work output) and the entropy change are

$$w_{out} = h_1 - h_2 = (h_1 - h_2)_{ideal} - RT'_{cr} (Z_{h1} - Z_{h2})$$

$$= 33.5 - (0.06855)(237.9)(0.725 - 0.0179)$$

$$= \mathbf{22.0 \text{ Btu/lbm}}$$

$$s_2 - s_1 = (s_2 - s_1)_{ideal} - R(Z_{s2} - Z_{s1})$$

$$= 0.2370 - (0.06855)(0.00906 - 0.339)$$

$$= \mathbf{0.2596 \text{ Btu/lbm} \cdot \text{R}}$$

The entropy change in this case is equal to the entropy generation during the process since the process is adiabatic. The positive value of entropy generation shows that this process is possible.

13-70 Heat is transferred to a gas mixture contained in a piston cylinder device. The initial state and the final temperature are given. The heat transfer is to be determined for the ideal gas and non-ideal gas cases.

Properties The molar masses of H₂ and N₂ are 2.0, and 28.0 kg/kmol. (Table A-1).

Analysis From the energy balance relation,

$$\begin{aligned} E_{\text{in}} - E_{\text{out}} &= \Delta E \\ Q_{\text{in}} - W_{b,\text{out}} &= \Delta U \\ Q_{\text{in}} &= \Delta H = \Delta H_{\text{H}_2} + \Delta H_{\text{N}_2} = N_{\text{H}_2}(\bar{h}_2 - \bar{h}_1)_{\text{H}_2} + N_{\text{N}_2}(\bar{h}_2 - \bar{h}_1)_{\text{N}_2} \end{aligned}$$

since W_b and ΔU combine into ΔH for quasi-equilibrium constant pressure processes

$$\begin{aligned} N_{\text{H}_2} &= \frac{m_{\text{H}_2}}{M_{\text{H}_2}} = \frac{6 \text{ kg}}{2 \text{ kg/kmol}} = 3 \text{ kmol} \\ N_{\text{N}_2} &= \frac{m_{\text{N}_2}}{M_{\text{N}_2}} = \frac{21 \text{ kg}}{28 \text{ kg/kmol}} = 0.75 \text{ kmol} \end{aligned}$$

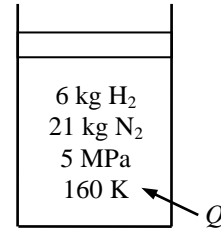

(a) Assuming ideal gas behavior, the inlet and exit enthalpies of H₂ and N₂ are determined from the ideal gas tables to be

$$\begin{aligned} \text{H}_2: \quad \bar{h}_1 &= \bar{h}_{@160 \text{ K}} = 4,535.4 \text{ kJ/kmol}, & \bar{h}_2 &= \bar{h}_{@200 \text{ K}} = 5,669.2 \text{ kJ/kmol} \\ \text{N}_2: \quad \bar{h}_1 &= \bar{h}_{@160 \text{ K}} = 4,648 \text{ kJ/kmol}, & \bar{h}_2 &= \bar{h}_{@200 \text{ K}} = 5,810 \text{ kJ/kmol} \end{aligned}$$

Thus, $Q_{\text{ideal}} = 3 \times (5,669.2 - 4,535.4) + 0.75 \times (5,810 - 4,648) = \mathbf{4273 \text{ kJ}}$

(b) Using Amagat's law and the generalized enthalpy departure chart, the enthalpy change of each gas is determined to be

$$\text{H}_2: \left. \begin{aligned} T_{R_1, \text{H}_2} &= \frac{T_{m,1}}{T_{\text{cr}, \text{H}_2}} = \frac{160}{33.3} = 4.805 \\ P_{R_1, \text{H}_2} &= P_{R_2, \text{H}_2} = \frac{P_m}{P_{\text{cr}, \text{H}_2}} = \frac{5}{1.30} = 3.846 \\ T_{R_2, \text{H}_2} &= \frac{T_{m,2}}{T_{\text{cr}, \text{H}_2}} = \frac{200}{33.3} = 6.006 \end{aligned} \right\} \begin{aligned} Z_{h_1} &\cong 0 \\ Z_{h_2} &\cong 0 \end{aligned} \quad (\text{Fig. A-29})$$

Thus H₂ can be treated as an ideal gas during this process.

$$\text{N}_2: \left. \begin{aligned} T_{R_1, \text{N}_2} &= \frac{T_{m,1}}{T_{\text{cr}, \text{N}_2}} = \frac{160}{126.2} = 1.27 \\ P_{R_1, \text{N}_2} &= P_{R_2, \text{N}_2} = \frac{P_m}{P_{\text{cr}, \text{N}_2}} = \frac{5}{3.39} = 1.47 \\ T_{R_2, \text{N}_2} &= \frac{T_{m,2}}{T_{\text{cr}, \text{N}_2}} = \frac{200}{126.2} = 1.58 \end{aligned} \right\} \begin{aligned} Z_{h_1} &= 1.3 \\ Z_{h_2} &= 0.7 \end{aligned} \quad (\text{Fig. A-29})$$

Therefore,

$$\begin{aligned} (\bar{h}_2 - \bar{h}_1)_{\text{H}_2} &= (\bar{h}_2 - \bar{h}_1)_{\text{H}_2, \text{ideal}} = 5,669.2 - 4,535.4 = 1,133.8 \text{ kJ/kmol} \\ (\bar{h}_2 - \bar{h}_1)_{\text{N}_2} &= R_u T_{\text{cr}} (Z_{h_1} - Z_{h_2}) + (\bar{h}_2 - \bar{h}_1)_{\text{ideal}} \\ &= (8.314 \text{ kPa} \cdot \text{m}^3 / \text{kmol} \cdot \text{K})(126.2 \text{ K})(1.3 - 0.7) + (5,810 - 4,648) \text{ kJ/kmol} = 1,791.5 \text{ kJ/kmol} \end{aligned}$$

Substituting,

$$Q_{\text{in}} = (3 \text{ kmol})(1,133.8 \text{ kJ/kmol}) + (0.75 \text{ kmol})(1,791.5 \text{ kJ/kmol}) = \mathbf{4745 \text{ kJ}}$$

13-71 Heat is transferred to a gas mixture contained in a piston cylinder device discussed in previous problem. The total entropy change and the exergy destruction are to be determined for two cases.

Analysis The entropy generated during this process is determined by applying the entropy balance on an *extended system* that includes the piston-cylinder device and its immediate surroundings so that the boundary temperature of the extended system is the environment temperature at all times. It gives

$$S_{\text{in}} - S_{\text{out}} + S_{\text{gen}} = \Delta S_{\text{system}}$$

$$\frac{Q_{\text{in}}}{T_{\text{boundary}}} + S_{\text{gen}} = \Delta S_{\text{water}} \rightarrow S_{\text{gen}} = m(s_2 - s_1) - \frac{Q_{\text{in}}}{T_{\text{surr}}}$$

Then the exergy destroyed during a process can be determined from its definition $X_{\text{destroyed}} = T_0 S_{\text{gen}}$.

(a) Noting that the total mixture pressure, and thus the partial pressure of each gas, remains constant, the entropy change of a component in the mixture during this process is

$$\Delta S_i = m_i \left(c_p \ln \frac{T_2}{T_1} - R \ln \frac{P_2}{P_1} \right) = m_i c_{p,i} \ln \frac{T_2}{T_1}$$

Assuming ideal gas behavior and using c_p values at the average temperature, the ΔS of H_2 and N_2 are determined from

$$\Delta S_{\text{H}_2, \text{ideal}} = (6 \text{ kg})(13.60 \text{ kJ/kg} \cdot \text{K}) \ln \frac{200 \text{ K}}{160 \text{ K}} = 18.21 \text{ kJ/K}$$

$$\Delta S_{\text{N}_2, \text{ideal}} = (21 \text{ kg})(1.039 \text{ kJ/kg} \cdot \text{K}) \ln \frac{200 \text{ K}}{160 \text{ K}} = 4.87 \text{ kJ/K}$$

and

$$S_{\text{gen}} = 18.21 \text{ kJ/K} + 4.87 \text{ kJ/K} - \frac{4273 \text{ kJ}}{293 \text{ K}} = \mathbf{8.496 \text{ kJ/K}}$$

$$X_{\text{destroyed}} = T_0 S_{\text{gen}} = (293 \text{ K})(8.496 \text{ kJ/K}) = \mathbf{2489 \text{ kJ}}$$

(b) Using Amagat's law and the generalized entropy departure chart, the entropy change of each gas is determined to be

$$\text{H}_2: \left. \begin{aligned} T_{R_1, \text{H}_2} &= \frac{T_{m,1}}{T_{\text{cr}, \text{H}_2}} = \frac{160}{33.3} = 4.805 \\ P_{R_1, \text{H}_2} &= P_{R_2, \text{H}_2} = \frac{P_m}{P_{\text{cr}, \text{H}_2}} = \frac{5}{1.30} = 3.846 \\ T_{R_2, \text{H}_2} &= \frac{T_{m,2}}{T_{\text{cr}, \text{H}_2}} = \frac{200}{33.3} = 6.006 \end{aligned} \right\} \begin{aligned} Z_{s_1} &\cong 1 \\ Z_{s_2} &\cong 1 \end{aligned} \quad (\text{Table A-30})$$

Thus H_2 can be treated as an ideal gas during this process.

$$\text{N}_2: \left. \begin{aligned} T_{R_1, \text{N}_2} &= \frac{T_{m,1}}{T_{\text{cr}, \text{N}_2}} = \frac{160}{126.2} = 1.268 \\ P_{R_1, \text{N}_2} &= P_{R_2, \text{N}_2} = \frac{P_m}{P_{\text{cr}, \text{N}_2}} = \frac{5}{3.39} = 1.475 \\ T_{R_2, \text{N}_2} &= \frac{T_{m,2}}{T_{\text{cr}, \text{N}_2}} = \frac{200}{126.2} = 1.585 \end{aligned} \right\} \begin{aligned} Z_{s_1} &= 0.8 \\ Z_{s_2} &= 0.4 \end{aligned} \quad (\text{Table A-30})$$

Therefore,

$$\Delta S_{\text{H}_2} = \Delta S_{\text{H}_2, \text{ideal}} = 18.21 \text{ kJ/K}$$

$$\begin{aligned} \Delta S_{\text{N}_2} &= N_{\text{N}_2} R_u (Z_{s_1} - Z_{s_2}) + \Delta S_{\text{N}_2, \text{ideal}} \\ &= (0.75 \text{ kmol})(8.314 \text{ kPa} \cdot \text{m}^3/\text{kmol} \cdot \text{K})(0.8 - 0.4) + (4.87 \text{ kJ/K}) \\ &= 7.37 \text{ kJ/K} \end{aligned}$$

$$\Delta S_{\text{sur}} = \frac{Q_{\text{sur}}}{T_0} = \frac{-4745 \text{ kJ}}{293 \text{ K}} = -16.19 \text{ kJ/K}$$

and

$$S_{\text{gen}} = 18.21 \text{ kJ/K} + 7.37 \text{ kJ/K} - 16.19 = \mathbf{9.390 \text{ kJ/K}}$$

$$X_{\text{destroyed}} = T_0 S_{\text{gen}} = (293 \text{ K})(9.385 \text{ kJ/K}) = \mathbf{2751 \text{ kJ}}$$

13-72 Two mass streams of two different ideal gases are mixed in a steady-flow chamber while receiving energy by heat transfer from the surroundings. Expressions for the final temperature and the exit volume flow rate are to be obtained and two special cases are to be evaluated.

Assumptions Kinetic and potential energy changes are negligible.

Analysis (a) Mass and energy balances for the mixing process:

$$\dot{m}_1 + \dot{m}_2 = \dot{m}_3$$

$$\dot{m}_1 h_1 + \dot{m}_2 h_2 + \dot{Q}_{in} = \dot{m}_3 h_3$$

$$h = C_p T$$

$$\dot{m}_1 C_{p,1} T_1 + \dot{m}_2 C_{p,2} T_2 + \dot{Q}_{in} = \dot{m}_3 C_{p,m} T_3$$

$$C_{p,m} = \frac{\dot{m}_1}{\dot{m}_3} C_{p,1} + \frac{\dot{m}_2}{\dot{m}_3} C_{p,2}$$

$$T_3 = \frac{\dot{m}_1 C_{p,1}}{\dot{m}_3 C_{p,m}} T_1 + \frac{\dot{m}_2 C_{p,2}}{\dot{m}_3 C_{p,m}} T_2 + \frac{\dot{Q}_{in}}{\dot{m}_3 C_{p,m}}$$

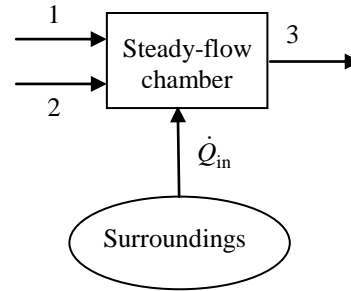

(b) The expression for the exit volume flow rate is obtained as follows:

$$\dot{V}_3 = \dot{m}_3 v_3 = \dot{m}_3 \frac{R_3 T_3}{P_3}$$

$$\dot{V}_3 = \frac{\dot{m}_3 R_3}{P_3} \left[\frac{\dot{m}_1 C_{p,1}}{\dot{m}_3 C_{p,m}} T_1 + \frac{\dot{m}_2 C_{p,2}}{\dot{m}_3 C_{p,m}} T_2 + \frac{\dot{Q}_{in}}{\dot{m}_3 C_{p,m}} \right]$$

$$\dot{V}_3 = \frac{C_{p,1} R_3}{C_{p,m} R_1} \frac{\dot{m}_1 R_1 T_1}{P_3} + \frac{C_{p,2} R_3}{C_{p,m} R_2} \frac{\dot{m}_2 R_2 T_2}{P_3} + \frac{R_3 \dot{Q}_{in}}{P_3 C_{p,m}}$$

$$P_3 = P_1 = P_2$$

$$\dot{V}_3 = \frac{C_{p,1} R_3}{C_{p,m} R_1} \dot{V}_1 + \frac{C_{p,2} R_3}{C_{p,m} R_2} \dot{V}_2 + \frac{R_3 \dot{Q}_{in}}{P_3 C_{p,m}}$$

$$R = \frac{R_u}{M}, \quad \frac{R_3}{R_1} = \frac{R_u}{M_3} \frac{M_1}{R_u} = \frac{M_1}{M_3}, \quad \frac{R_3}{R_2} = \frac{M_2}{M_3}$$

$$\dot{V}_3 = \frac{C_{p,1} M_1}{C_{p,m} M_3} \dot{V}_1 + \frac{C_{p,2} M_2}{C_{p,m} M_3} \dot{V}_2 + \frac{R_u \dot{Q}_{in}}{P_3 M_3 C_{p,m}}$$

The mixture molar mass M_3 is found as follows:

$$M_3 = \sum y_i M_i, \quad y_i = \frac{m_{fi} / M_i}{\sum m_{fi} / M_i}, \quad m_{fi} = \sum \dot{m}_i$$

(c) For adiabatic mixing \dot{Q}_{in} is zero, and the mixture volume flow rate becomes

$$\dot{V}_3 = \frac{C_{p,1} M_1}{C_{p,m} M_3} \dot{V}_1 + \frac{C_{p,2} M_2}{C_{p,m} M_3} \dot{V}_2$$

(d) When adiabatically mixing the same two ideal gases, the mixture volume flow rate becomes

$$M_3 = M_1 = M_2$$

$$C_{p,3} = C_{p,1} = C_{p,2}$$

$$\dot{V}_3 = \dot{V}_1 + \dot{V}_2$$

Special Topic: Chemical Potential and the Separation Work of Mixtures

13-73C No, a process that separates a mixture into its components without requiring any work (exergy) input is impossible since such a process would violate the 2nd law of thermodynamics.

13-74C Yes, the volume of the mixture can be more or less than the sum of the initial volumes of the mixing liquids because of the attractive or repulsive forces acting between dissimilar molecules.

13-75C The person who claims that the temperature of the mixture can be higher than the temperatures of the components is right since the total enthalpy of the mixture of two components at the same pressure and temperature, in general, is not equal to the sum of the total enthalpies of the individual components before mixing, the difference being the enthalpy (or heat) of mixing, which is the heat released or absorbed as two or more components are mixed isothermally.

13-76C Mixtures or solutions in which the effects of molecules of different components on each other are negligible are called ideal solutions (or ideal mixtures). The ideal-gas mixture is just one category of ideal solutions. For ideal solutions, the enthalpy change and the volume change due to mixing are zero, but the entropy change is not. The chemical potential of a component of an ideal mixture is independent of the identity of the other constituents of the mixture. The chemical potential of a component in an ideal mixture is equal to the Gibbs function of the pure component.

13-77 Brackish water is used to produce fresh water. The minimum power input and the minimum height the brackish water must be raised by a pump for reverse osmosis are to be determined.

Assumptions 1 The brackish water is an ideal solution since it is dilute. **2** The total dissolved solids in water can be treated as table salt (NaCl). **3** The environment temperature is also 18°C.

Properties The molar masses of water and salt are $M_w = 18.0 \text{ kg/kmol}$ and $M_s = 58.44 \text{ kg/kmol}$. The gas constant of pure water is $R_w = 0.4615 \text{ kJ/kg}\cdot\text{K}$ (Table A-1). The density of fresh water is 1000 kg/m^3 .

Analysis First we determine the mole fraction of pure water in brackish water using Eqs. 13-4 and 13-5. Noting that $mf_s = 0.00078$ and $mf_w = 1 - mf_s = 0.99922$,

$$M_m = \frac{1}{\sum \frac{mf_i}{M_i}} = \frac{1}{\frac{mf_s}{M_s} + \frac{mf_w}{M_w}} = \frac{1}{\frac{0.00078}{58.44} + \frac{0.99922}{18.0}} = 18.01 \text{ kg/kmol}$$

$$y_i = mf_i \frac{M_m}{M_i} \rightarrow y_w = mf_w \frac{M_m}{M_w} = (0.99922) \frac{18.01 \text{ kg/kmol}}{18.0 \text{ kg/kmol}} = 0.99976$$

The minimum work input required to produce 1 kg of freshwater from brackish water is

$$w_{\min, \text{in}} = R_w T_0 \ln(1/y_w) = (0.4615 \text{ kJ/kg}\cdot\text{K})(291.15 \text{ K}) \ln(1/0.99976) = 0.03230 \text{ kJ/kg fresh water}$$

Therefore, 0.03159 kJ of work is needed to produce 1 kg of fresh water is mixed with seawater reversibly. Therefore, the required power input to produce fresh water at the specified rate is

$$\dot{W}_{\min, \text{in}} = \rho \dot{V} w_{\min, \text{in}} = (1000 \text{ kg/m}^3)(0.175 \text{ m}^3/\text{s})(0.03230 \text{ kJ/kg}) \left(\frac{1 \text{ kW}}{1 \text{ kJ/s}} \right) = \mathbf{5.65 \text{ kW}}$$

The minimum height to which the brackish water must be pumped is

$$\Delta z_{\min} = \frac{w_{\min, \text{in}}}{g} = \left(\frac{0.03230 \text{ kJ/kg}}{9.81 \text{ m/s}^2} \right) \left(\frac{1 \text{ kg}\cdot\text{m/s}^2}{1 \text{ N}} \right) \left(\frac{1000 \text{ N}\cdot\text{m}}{1 \text{ kJ}} \right) = \mathbf{3.29 \text{ m}}$$

13-78 A river is discharging into the ocean at a specified rate. The amount of power that can be generated is to be determined.

Assumptions 1 The seawater is an ideal solution since it is dilute. **2** The total dissolved solids in water can be treated as table salt (NaCl). **3** The environment temperature is also 15°C.

Properties The molar masses of water and salt are $M_w = 18.0 \text{ kg/kmol}$ and $M_s = 58.44 \text{ kg/kmol}$. The gas constant of pure water is $R_w = 0.4615 \text{ kJ/kg}\cdot\text{K}$ (Table A-1). The density of river water is 1000 kg/m^3 .

Analysis First we determine the mole fraction of pure water in ocean water using Eqs. 13-4 and 13-5. Noting that $mf_s = 0.025$ and $mf_w = 1 - mf_s = 0.975$,

$$M_m = \frac{1}{\sum \frac{mf_i}{M_i}} = \frac{1}{\frac{mf_s}{M_s} + \frac{mf_w}{M_w}} = \frac{1}{\frac{0.025}{58.44} + \frac{0.975}{18.0}} = 18.32 \text{ kg/kmol}$$

$$y_i = mf_i \frac{M_m}{M_i} \rightarrow y_w = mf_w \frac{M_m}{M_w} = (0.975) \frac{18.32 \text{ kg/kmol}}{18.0 \text{ kg/kmol}} = 0.9922$$

The maximum work output associated with mixing 1 kg of seawater (or the minimum work input required to produce 1 kg of freshwater from seawater) is

$$w_{\max, \text{out}} = R_w T_0 \ln(1/y_w) = (0.4615 \text{ kJ/kg}\cdot\text{K})(288.15 \text{ K})\ln(1/0.9922) = 1.046 \text{ kJ/kg fresh water}$$

Therefore, 1.046 kJ of work can be produced as 1 kg of fresh water is mixed with seawater reversibly. Therefore, the power that can be generated as a river with a flow rate of $400,000 \text{ m}^3/\text{s}$ mixes reversibly with seawater is

$$\dot{W}_{\max \text{ out}} = \rho \dot{V} w_{\max \text{ out}} = (1000 \text{ kg/m}^3)(1.5 \times 10^5 \text{ m}^3/\text{s})(1.046 \text{ kJ/kg}) \left(\frac{1 \text{ kW}}{1 \text{ kJ/s}} \right) = \mathbf{157 \times 10^6 \text{ kW}}$$

Discussion This is more power than produced by all nuclear power plants (112 of them) in the U.S., which shows the tremendous amount of power potential wasted as the rivers discharge into the seas.

13-79  Problem 13-78 is reconsidered. The effect of the salinity of the ocean on the maximum power generated is to be investigated.

Analysis The problem is solved using EES, and the solution is given below.

"Given"

$$V_{\dot{}}=150000 \text{ [m}^3\text{/s]}$$

"salinity=2.5"

$$T=(15+273.15) \text{ [K]}$$

"Properties"

$$M_w=18 \text{ [kg/kmol]} \text{ "molar mass (H}_2\text{O)"}$$

$$M_s=58.44 \text{ [kg/kmol]} \text{ "molar mass of salt"}$$

$$R_w=0.4615 \text{ [kJ/kg-K]} \text{ "gas constant of water"}$$

$$\rho=1000 \text{ [kg/m}^3\text{]}$$

"Analysis"

$$\text{mass}_w=100-\text{salinity}$$

$$\text{mf}_s=\text{salinity}/100$$

$$\text{mf}_w=\text{mass}_w/100$$

$$M_m=1/(\text{mf}_s/M_s+\text{mf}_w/M_w)$$

$$y_w=\text{mf}_w*M_m/M_w$$

$$w_{\text{max,out}}=R_w*T*\ln(1/y_w)$$

$$W_{\dot{\text{max,out}}}=\rho*V_{\dot{}}*w_{\text{max,out}}$$

Salinity [%]	$W_{\text{max,out}}$ [kW]
0	0
0.5	3.085E+07
1	6.196E+07
1.5	9.334E+07
2	1.249E+08
2.5	1.569E+08
3	1.891E+08
3.5	2.216E+08
4	2.544E+08
4.5	2.874E+08
5	3.208E+08

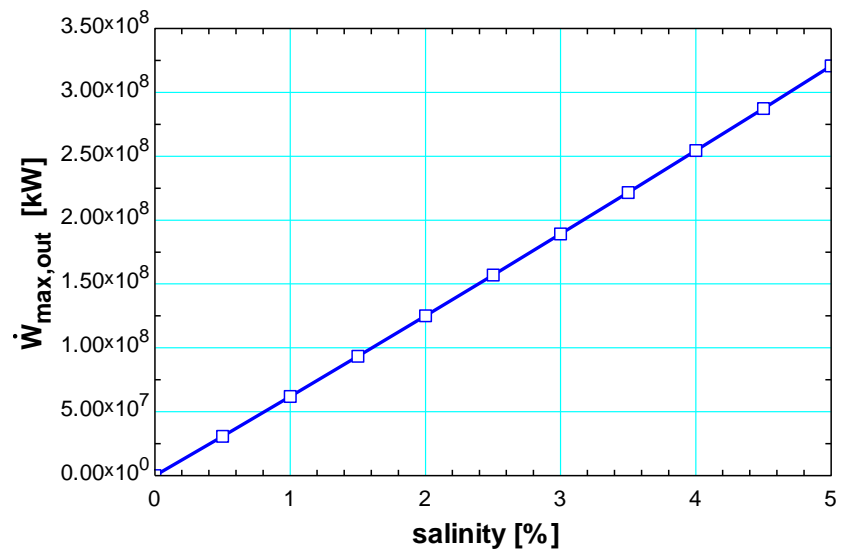

13-80E Brackish water is used to produce fresh water. The mole fractions, the minimum work inputs required to separate 1 lbm of brackish water and to obtain 1 lbm of fresh water are to be determined.

Assumptions 1 The brackish water is an ideal solution since it is dilute. **2** The total dissolved solids in water can be treated as table salt (NaCl). **3** The environment temperature is equal to the water temperature.

Properties The molar masses of water and salt are $M_w = 18.0$ lbm/lbmol and $M_s = 58.44$ lbm/lbmol. The gas constant of pure water is $R_w = 0.1102$ Btu/lbm·R (Table A-1E).

Analysis (a) First we determine the mole fraction of pure water in brackish water using Eqs. 13-4 and 13-5. Noting that $mf_s = 0.0012$ and $mf_w = 1 - mf_s = 0.9988$,

$$M_m = \frac{1}{\sum \frac{mf_i}{M_i}} = \frac{1}{\frac{mf_s}{M_s} + \frac{mf_w}{M_w}} = \frac{1}{\frac{0.0012}{58.44} + \frac{0.9988}{18.0}} = 18.015 \text{ lbm/lbmol}$$

$$y_i = mf_i \frac{M_m}{M_i} \rightarrow y_w = mf_w \frac{M_m}{M_w} = (0.9988) \frac{18.015 \text{ lbm/lbmol}}{18.0 \text{ lbm/lbmol}} = \mathbf{0.99963}$$

$$y_s = 1 - y_w = 1 - 0.99963 = \mathbf{0.00037}$$

(b) The minimum work input required to separate 1 lbmol of brackish water is

$$\begin{aligned} w_{\min, \text{in}} &= -R_w T_0 (y_w \ln y_w + y_s \ln y_s) \\ &= -(0.1102 \text{ Btu/lbmol}\cdot\text{R})(525 \text{ R})[0.99963 \ln(0.99963) + 0.00037 \ln(0.00037)] \\ &= \mathbf{-0.191 \text{ Btu/lbm brackish water}} \end{aligned}$$

(c) The minimum work input required to produce 1 lbm of freshwater from brackish water is

$$w_{\min, \text{in}} = R_w T_0 \ln(1/y_w) = (0.1102 \text{ Btu/lbm}\cdot\text{R})(525 \text{ R}) \ln(1/0.99963) = \mathbf{0.0214 \text{ Btu/lbm fresh water}}$$

Discussion Note that it takes about 9 times work to separate 1 lbm of brackish water into pure water and salt compared to producing 1 lbm of fresh water from a large body of brackish water.

13-81 A desalination plant produces fresh water from seawater. The second law efficiency of the plant is to be determined.

Assumptions 1 The seawater is an ideal solution since it is dilute. **2** The total dissolved solids in water can be treated as table salt (NaCl). **3** The environment temperature is equal to the seawater temperature.

Properties The molar masses of water and salt are $M_w = 18.0 \text{ kg/kmol}$ and $M_s = 58.44 \text{ kg/kmol}$. The gas constant of pure water is $R_w = 0.4615 \text{ kJ/kg}\cdot\text{K}$ (Table A-1). The density of river water is 1000 kg/m^3 .

Analysis First we determine the mole fraction of pure water in seawater using Eqs. 13-4 and 13-5. Noting that $mf_s = 0.032$ and $mf_w = 1 - mf_s = 0.968$,

$$M_m = \frac{1}{\sum \frac{mf_i}{M_i}} = \frac{1}{\frac{mf_s}{M_s} + \frac{mf_w}{M_w}} = \frac{1}{\frac{0.032}{58.44} + \frac{0.968}{18.0}} = 18.41 \text{ kg/kmol}$$

$$y_i = mf_i \frac{M_m}{M_i} \rightarrow y_w = mf_w \frac{M_m}{M_w} = (0.968) \frac{18.41 \text{ kg/kmol}}{18.0 \text{ kg/kmol}} = 0.9900$$

The maximum work output associated with mixing 1 kg of seawater (or the minimum work input required to produce 1 kg of freshwater from seawater) is

$$w_{\max, \text{out}} = R_w T_0 \ln(1/y_w) = (0.4615 \text{ kJ/kg}\cdot\text{K})(283.15 \text{ K})\ln(1/0.990) = 1.313 \text{ kJ/kg fresh water}$$

The power that can be generated as $1.4 \text{ m}^3/\text{s}$ fresh water mixes reversibly with seawater is

$$\dot{W}_{\max \text{ out}} = \rho \dot{V} w_{\max \text{ out}} = (1000 \text{ kg/m}^3)(1.4 \text{ m}^3/\text{s})(1.313 \text{ kJ/kg}) \left(\frac{1 \text{ kW}}{1 \text{ kJ/s}} \right) = 1.84 \text{ kW}$$

Then the second law efficiency of the plant becomes

$$\eta_{\text{II}} = \frac{\dot{W}_{\min, \text{in}}}{\dot{W}_{\text{in}}} = \frac{1.83 \text{ MW}}{8.5 \text{ MW}} = 0.216 = \mathbf{21.6\%}$$

13-82 The power consumption and the second law efficiency of a desalination plant are given. The power that can be produced if the fresh water produced is mixed with the seawater reversibly is to be determined.

Assumptions 1 This is a steady-flow process. **2** The kinetic and potential energy changes are negligible.

Analysis From the definition of the second law efficiency

$$\eta_{\text{II}} = \frac{\dot{W}_{\text{rev}}}{\dot{W}_{\text{actual}}} \rightarrow 0.20 = \frac{\dot{W}_{\text{rev}}}{11,500 \text{ kW}} \rightarrow \dot{W}_{\text{rev}} = \mathbf{2300 \text{ kW}}$$

which is the maximum power that can be generated.

13-83E It is to be determined if it is possible for an adiabatic liquid-vapor separator to separate wet steam at 100 psia and 90 percent quality, so that the pressure of the outlet streams is greater than 100 psia.

Analysis Because the separator divides the inlet stream into the liquid and vapor portions,

$$\dot{m}_2 = x\dot{m}_1 = 0.9\dot{m}_1$$

$$\dot{m}_3 = (1-x)\dot{m}_1 = 0.1\dot{m}_1$$

According to the water property tables at 100 psia (Table A-5E),

$$s_1 = s_f + xs_{fg} = 0.47427 + 0.9 \times 1.12888 = 1.4903 \text{ Btu/lbm} \cdot \text{R}$$

When the increase in entropy principle is adapted to this system, it becomes

$$\begin{aligned} \dot{m}_2 s_2 + \dot{m}_3 s_3 &\geq \dot{m}_1 s_1 \\ x\dot{m}_1 s_2 + (1-x)\dot{m}_1 s_3 &\geq \dot{m}_1 s_1 \\ 0.9s_2 + 0.1s_3 &\geq s_1 \\ &\geq 1.4903 \text{ Btu/lbm} \cdot \text{R} \end{aligned}$$

To test this hypothesis, let's assume the outlet pressures are 110 psia. Then,

$$s_2 = s_g = 1.5954 \text{ Btu/lbm} \cdot \text{R}$$

$$s_3 = s_f = 0.48341 \text{ Btu/lbm} \cdot \text{R}$$

The left-hand side of the above equation is

$$0.9s_2 + 0.1s_3 = 0.9 \times 1.5954 + 0.1 \times 0.48341 = 1.4842 \text{ Btu/lbm} \cdot \text{R}$$

which is less than the minimum possible specific entropy. Hence, the outlet pressure cannot be 110 psia. Inspection of the water table in light of above equation proves that the pressure at the separator outlet cannot be greater than that at the inlet.

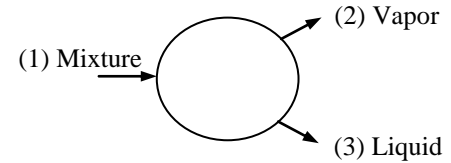

Review Problems

13-84 The volume fractions of components of a gas mixture are given. The mole fractions, the mass fractions, the partial pressures, the mixture molar mass, apparent gas constant, and constant-pressure specific heat are to be determined and compared to the values in Table A-2a.

Properties The molar masses of N_2 , O_2 and Ar are 28.0, 32.0, and 40.0 kg/kmol, respectively (Table A-1). The constant-pressure specific heats of these gases at 300 K are 1.039, 0.918, and 0.5203 kJ/kg·K, respectively (Table A-2a).

Analysis The volume fractions are equal to the mole fractions:

$$y_{N_2} = \mathbf{0.78}, \quad y_{O_2} = \mathbf{0.21}, \quad y_{Ar} = \mathbf{0.01}$$

The volume fractions are equal to the pressure fractions. The partial pressures are then

$$P_{N_2} = y_{N_2} P_{\text{total}} = (0.78)(100 \text{ kPa}) = \mathbf{78 \text{ kPa}}$$

$$P_{O_2} = y_{O_2} P_{\text{total}} = (0.21)(100 \text{ kPa}) = \mathbf{21 \text{ kPa}}$$

$$P_{Ar} = y_{Ar} P_{\text{total}} = (0.01)(100 \text{ kPa}) = \mathbf{1 \text{ kPa}}$$

<p>78% N_2 21% O_2 1% Ar (by volume)</p>
--

We consider 100 kmol of this mixture. Noting that volume fractions are equal to the mole fractions, mass of each component are

$$m_{N_2} = N_{N_2} M_{N_2} = (78 \text{ kmol})(28 \text{ kg/kmol}) = 2184 \text{ kg}$$

$$m_{O_2} = N_{O_2} M_{O_2} = (21 \text{ kmol})(32 \text{ kg/kmol}) = 672 \text{ kg}$$

$$m_{Ar} = N_{Ar} M_{Ar} = (1 \text{ kmol})(40 \text{ kg/kmol}) = 40 \text{ kg}$$

The total mass is

$$m_m = m_{N_2} + m_{O_2} + m_{Ar} = 2184 + 672 + 40 = 2896 \text{ kg}$$

Then the mass fractions are

$$\text{mf}_{N_2} = \frac{m_{N_2}}{m_m} = \frac{2184 \text{ kg}}{2896 \text{ kg}} = \mathbf{0.7541}$$

$$\text{mf}_{O_2} = \frac{m_{O_2}}{m_m} = \frac{672 \text{ kg}}{2896 \text{ kg}} = \mathbf{0.2320}$$

$$\text{mf}_{Ar} = \frac{m_{Ar}}{m_m} = \frac{40 \text{ kg}}{2896 \text{ kg}} = \mathbf{0.0138}$$

The apparent molecular weight of the mixture is

$$M_m = \frac{m_m}{N_m} = \frac{2896 \text{ kg}}{100 \text{ kmol}} = \mathbf{28.96 \text{ kg/kmol}}$$

The constant-pressure specific heat of the mixture is determined from

$$\begin{aligned} c_p &= \text{mf}_{N_2} c_{p,N_2} + \text{mf}_{O_2} c_{p,O_2} + \text{mf}_{Ar} c_{p,Ar} \\ &= 0.7541 \times 1.039 + 0.2320 \times 0.918 + 0.0138 \times 0.5203 \\ &= \mathbf{1.004 \text{ kJ/kg} \cdot \text{K}} \end{aligned}$$

The apparent gas constant of the mixture is

$$R = \frac{R_u}{M_m} = \frac{8.314 \text{ kJ/kmol} \cdot \text{K}}{28.96 \text{ kg/kmol}} = \mathbf{0.2871 \text{ kJ/kg} \cdot \text{K}}$$

This mixture closely correspond to the air, and the mixture properties determined (mixture molar mass, mixture gas constant and mixture specific heat) are practically the same as those listed for air in Tables A-1 and A-2a.

13-85 The mole numbers of combustion gases are given. The partial pressure of water vapor and the condensation temperature of water vapor are to be determined.

Properties The molar masses of CO_2 , H_2O , O_2 and N_2 are 44.0, 18.0, 32.0, and 28.0 kg/kmol, respectively (Table A-1).

Analysis The total mole of the mixture and the mole fraction of water vapor are

$$N_{\text{total}} = 8 + 9 + 4 + 94 = 115 \text{ kmol}$$

$$y_{\text{H}_2\text{O}} = \frac{N_{\text{H}_2\text{O}}}{N_{\text{total}}} = \frac{9}{115} = 0.07826$$

Noting that molar fraction is equal to pressure fraction, the partial pressure of water vapor is

$$P_{\text{H}_2\text{O}} = y_{\text{H}_2\text{O}} P_{\text{total}} = (0.07826)(101 \text{ kPa}) = \mathbf{7.90 \text{ kPa}}$$

The temperature at which the condensation starts is the saturation temperature of water at this pressure. This is called the dew-point temperature. Then,

$$T_{\text{cond}} = T_{\text{sat}@7.90 \text{ kPa}} = \mathbf{41.3^\circ\text{C}} \quad (\text{Table A-5})$$

Water vapor in the combustion gases will start to condense when the temperature of the combustion gases drop to 41.3°C .

13-86 Carbon dioxide and oxygen contained in one tank and nitrogen contained in another tank are allowed to mix during which heat is supplied to the gases. The final pressure and temperature of the mixture and the total volume of the mixture are to be determined.

Assumptions Under specified conditions CO_2 , N_2 , and O_2 can be treated as ideal gases, and the mixture as an ideal gas mixture.

Properties The molar masses of CO_2 , N_2 , and O_2 are 44.0, 28.0, and 32.0 kg/kmol, respectively (Table A-1). The gas constants of CO_2 , N_2 , and O_2 are 0.1889, 0.2968, 2598 kJ/kg.K, respectively (Table A-2).

Analysis The molar mass of the mixture in tank 1 are

$$M_m = y_{\text{CO}_2} M_{\text{CO}_2} + y_{\text{O}_2} M_{\text{O}_2} = (0.625)(44) + (0.375)(32) = 39.5 \text{ kg/kmol}$$

The gas constant in tank 1 is

$$R_1 = \frac{R_u}{M_m} = \frac{8.314 \text{ kJ/kmol.K}}{39.5 \text{ kg/kmol}} = 0.2104 \text{ kJ/kg.K}$$

The volumes of the tanks and the total volume are

$$V_1 = \frac{m_1 R_1 T_1}{P_1} = \frac{(5 \text{ kg})(0.2104 \text{ kJ/kg.K})(30 + 273 \text{ K})}{125 \text{ kPa}} = 2.551 \text{ m}^3$$

$$V_2 = \frac{m_2 R_2 T_2}{P_2} = \frac{(10 \text{ kg})(0.2968 \text{ kJ/kg.K})(15 + 273 \text{ K})}{200 \text{ kPa}} = 4.276 \text{ m}^3$$

$$V_{\text{total}} = V_1 + V_2 = 2.551 + 4.276 = \mathbf{6.828 \text{ m}^3}$$

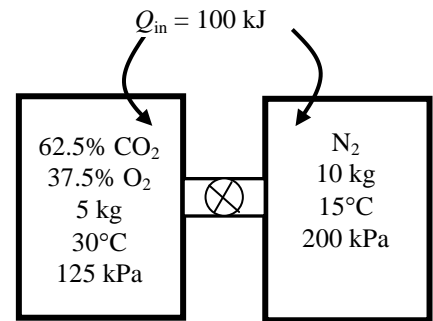

The mass fractions in tank 1 are

$$\text{mf}_{\text{CO}_2,1} = y_{\text{CO}_2} \frac{M_{\text{CO}_2}}{M_m} = (0.625) \frac{44 \text{ kg/kmol}}{39.5 \text{ kg/kmol}} = 0.6963 \quad \text{mf}_{\text{O}_2,1} = y_{\text{O}_2} \frac{M_{\text{O}_2}}{M_m} = (0.375) \frac{32 \text{ kg/kmol}}{39.5 \text{ kg/kmol}} = 0.3037$$

The masses in tank 1 and the total mass after mixing are

$$m_{\text{CO}_2,1} = \text{mf}_{\text{CO}_2,1} m_1 = (0.6963)(5 \text{ kg}) = 3.481 \text{ kg}$$

$$m_{\text{O}_2,1} = \text{mf}_{\text{O}_2,1} m_1 = (0.3037)(5 \text{ kg}) = 1.519 \text{ kg}$$

$$m_{\text{total}} = m_1 + m_2 = 5 + 10 = 15 \text{ kg}$$

The mass fractions of the combined mixture are

$$\text{mf}_{\text{CO}_2,2} = \frac{m_{\text{CO}_2,1}}{m_{\text{total}}} = \frac{3.481}{15} = 0.2321 \quad \text{mf}_{\text{O}_2,2} = \frac{m_{\text{O}_2,1}}{m_{\text{total}}} = \frac{1.519}{15} = 0.1012 \quad \text{mf}_{\text{N}_2,2} = \frac{m_2}{m_{\text{total}}} = \frac{10}{15} = 0.6667$$

The initial internal energies are

$$T_1 = 30^\circ\text{C} \longrightarrow \begin{aligned} u_{\text{CO}_2,1} &= 2 - 8995 \text{ kJ/kg} \\ u_{\text{O}_2,1} &= -74.16 \text{ kJ/kg} \end{aligned} \quad T_2 = 15^\circ\text{C} \longrightarrow u_{\text{N}_2,1} = -84.77 \text{ kJ/kg}$$

Noting that there is no work interaction, an energy balance gives

$$Q_{\text{in}} = m_{\text{total}} \Delta u_m$$

$$Q_{\text{in}} / m_{\text{total}} = \text{mf}_{\text{CO}_2,2} (u_{\text{CO}_2,2} - u_{\text{CO}_2,1}) + \text{mf}_{\text{O}_2,2} (u_{\text{O}_2,2} - u_{\text{O}_2,1}) + \text{mf}_{\text{N}_2,2} (u_{\text{N}_2,2} - u_{\text{N}_2,1})$$

$$(100 \text{ kJ}) / (15 \text{ kg}) = (0.2321) [u_{\text{CO}_2,2} - (-8995)] + (0.1012) [u_{\text{O}_2,2} - (-74.16)] + (0.6667) [u_{\text{N}_2,2} - (-84.77)]$$

The internal energies after the mixing are a function of mixture temperature only. Using EES, the final temperature of the mixture is determined to be

$$T_{\text{mix}} = \mathbf{312.4 \text{ K}}$$

The gas constant of the final mixture is

$$R_{\text{mix}} = \text{mf}_{\text{CO}_2,2} R_{\text{CO}_2} + \text{mf}_{\text{O}_2,2} R_{\text{O}_2} + \text{mf}_{\text{N}_2,2} R_{\text{N}_2}$$

$$= (0.2321)(0.1889) + (0.1012)(0.2598) + (0.6667)(0.2968) = 0.2680 \text{ kJ/kg.K}$$

The final pressure is determined from ideal gas relation to be

$$P_{\text{mix}} = \frac{m_{\text{total}} R_{\text{mix}} T_{\text{mix}}}{V_{\text{total}}} = \frac{(15 \text{ kg})(0.2680 \text{ kJ/kg.K})(312.4 \text{ K})}{6.828 \text{ m}^3} = \mathbf{184 \text{ kPa}}$$

13-87 The volumetric fractions of the constituents of combustion gases are given. The mixture undergoes a reversible adiabatic expansion process in a piston-cylinder device. The work done is to be determined.

Assumptions Under specified conditions all CO_2 , H_2O , O_2 , and N_2 can be treated as ideal gases, and the mixture as an ideal gas mixture.

Properties The molar masses of CO_2 , H_2O , O_2 , and N_2 are 44.0, 18.0, 32.0, and 28.0 kg/kmol, respectively (Table A-1).

Analysis Noting that volume fractions are equal to mole fractions in ideal gas mixtures, the molar mass of the mixture is determined to be

$$\begin{aligned} M_m &= y_{\text{CO}_2} M_{\text{CO}_2} + y_{\text{H}_2\text{O}} M_{\text{H}_2\text{O}} + y_{\text{O}_2} M_{\text{O}_2} + y_{\text{N}_2} M_{\text{N}_2} \\ &= (0.0489)(44) + (0.0650)(18) + (0.1220)(32) + (0.7641)(28) = 28.63 \text{ kg/kmol} \end{aligned}$$

The mass fractions are

$$\text{mf}_{\text{CO}_2} = y_{\text{CO}_2} \frac{M_{\text{CO}_2}}{M_m} = (0.0489) \frac{44 \text{ kg/kmol}}{28.63 \text{ kg/kmol}} = 0.07516$$

$$\text{mf}_{\text{H}_2\text{O}} = y_{\text{H}_2\text{O}} \frac{M_{\text{H}_2\text{O}}}{M_m} = (0.0650) \frac{18 \text{ kg/kmol}}{28.63 \text{ kg/kmol}} = 0.0409$$

$$\text{mf}_{\text{O}_2} = y_{\text{O}_2} \frac{M_{\text{O}_2}}{M_m} = (0.1220) \frac{32 \text{ kg/kmol}}{28.63 \text{ kg/kmol}} = 0.1363$$

$$\text{mf}_{\text{N}_2} = y_{\text{N}_2} \frac{M_{\text{N}_2}}{M_m} = (0.7641) \frac{28 \text{ kg/kmol}}{28.63 \text{ kg/kmol}} = 0.7476$$

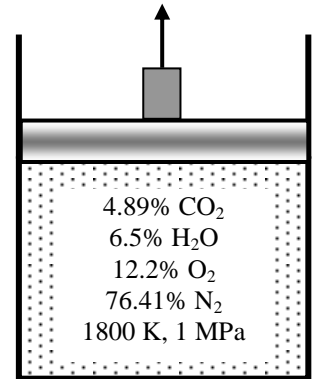

Using Dalton's law to find partial pressures, the entropies at the initial state are determined from EES to be:

$$T = 1800 \text{ K}, P = (0.0489 \times 1000) = 48.9 \text{ kPa} \longrightarrow s_{\text{CO}_2,1} = 7.0148 \text{ kJ/kg}\cdot\text{K}$$

$$T = 1800 \text{ K}, P = (0.0650 \times 1000) = 65 \text{ kPa} \longrightarrow s_{\text{H}_2\text{O},1} = 14.590 \text{ kJ/kg}\cdot\text{K}$$

$$T = 1800 \text{ K}, P = (0.1220 \times 1000) = 122 \text{ kPa} \longrightarrow s_{\text{N}_2,1} = 8.2570 \text{ kJ/kg}\cdot\text{K}$$

$$T = 1800 \text{ K}, P = (0.7641 \times 1000) = 764.1 \text{ kPa} \longrightarrow s_{\text{O}_2,1} = 8.2199 \text{ kJ/kg}\cdot\text{K}$$

The final state entropies cannot be determined at this point since the final temperature is not known. However, for an isentropic process, the entropy change is zero and the final temperature may be determined from

$$\Delta s_{\text{total}} = \text{mf}_{\text{CO}_2} \Delta s_{\text{CO}_2} + \text{mf}_{\text{H}_2\text{O}} \Delta s_{\text{H}_2\text{O}} + \text{mf}_{\text{O}_2} \Delta s_{\text{O}_2} + \text{mf}_{\text{N}_2} \Delta s_{\text{N}_2} = 0$$

The solution may be obtained using EES to be

$$T_2 = 1253 \text{ K}$$

The initial and final internal energies are (from EES)

$$\begin{array}{ll} T_1 = 1800 \text{ K} \longrightarrow & \begin{array}{l} u_{\text{CO}_2,1} = -7478 \text{ kJ/kg} \\ u_{\text{H}_2\text{O},1} = -10,779 \text{ kJ/kg} \\ u_{\text{O}_2,1} = 1147 \text{ kJ/kg} \\ u_{\text{N}_2,1} = 1214 \text{ kJ/kg} \end{array} & T_2 = 1253 \text{ K} \longrightarrow & \begin{array}{l} u_{\text{CO}_2,2} = -8102 \text{ kJ/kg} \\ u_{\text{H}_2\text{O},2} = -11,955 \text{ kJ/kg} \\ u_{\text{O}_2,2} = 662.8 \text{ kJ/kg} \\ u_{\text{N}_2,2} = 696.5 \text{ kJ/kg} \end{array} \end{array}$$

Noting that the heat transfer is zero, an energy balance on the system gives

$$q_{\text{in}} - w_{\text{out}} = \Delta u_m \longrightarrow w_{\text{out}} = -\Delta u_m$$

$$\text{where } \Delta u_m = \text{mf}_{\text{CO}_2} (u_{\text{CO}_2,2} - u_{\text{CO}_2,1}) + \text{mf}_{\text{H}_2\text{O}} (u_{\text{H}_2\text{O},2} - u_{\text{H}_2\text{O},1}) + \text{mf}_{\text{O}_2} (u_{\text{O}_2,2} - u_{\text{O}_2,1}) + \text{mf}_{\text{N}_2} (u_{\text{N}_2,2} - u_{\text{N}_2,1})$$

Substituting,

$$\begin{aligned} w_{\text{out}} = -\Delta u_m &= -0.07516[(-8102) - (-7478)] - 0.0409[(-11,955) - (-10,779)] \\ &\quad - 0.1363[662.8 - 1147] - 0.7476[696.5 - 1214] \\ &= \mathbf{547.8 \text{ kJ/kg}} \end{aligned}$$

13-88 The masses of gases forming a mixture at a specified pressure and temperature are given. The mass of the gas mixture is to be determined using four methods.

Properties The molar masses of O₂, CO₂, and He are 32.0, 44.0, and 4.0 kg/kmol, respectively (Table A-1).

Analysis (a) The given total mass of the mixture is

$$m_m = m_{\text{O}_2} + m_{\text{CO}_2} + m_{\text{He}} = 0.1 + 1 + 0.5 = 1.6 \text{ kg}$$

The mole numbers of each component are

$$N_{\text{O}_2} = \frac{m_{\text{O}_2}}{M_{\text{O}_2}} = \frac{0.1 \text{ kg}}{32 \text{ kg/kmol}} = 0.003125 \text{ kmol}$$

$$N_{\text{CO}_2} = \frac{m_{\text{CO}_2}}{M_{\text{CO}_2}} = \frac{1 \text{ kg}}{44 \text{ kg/kmol}} = 0.02273 \text{ kmol}$$

$$N_{\text{He}} = \frac{m_{\text{He}}}{M_{\text{He}}} = \frac{0.5 \text{ kg}}{4 \text{ kg/kmol}} = 0.125 \text{ kmol}$$

0.1 kg O ₂
1 kg CO ₂
0.5 kg He

The mole number of the mixture is

$$N_m = N_{\text{O}_2} + N_{\text{CO}_2} + N_{\text{He}} = 0.003125 + 0.02273 + 0.125 = 0.1509 \text{ kmol}$$

Then the apparent molecular weight of the mixture becomes

$$M_m = \frac{m_m}{N_m} = \frac{1.6 \text{ kg}}{0.1509 \text{ kmol}} = 10.61 \text{ kg/kmol}$$

The mass of this mixture in a 0.3 m³ tank is

$$m = \frac{M_m P V}{R_u T} = \frac{(10.61 \text{ kg/kmol})(17,500 \text{ kPa})(0.3 \text{ m}^3)}{(8.314 \text{ kPa} \cdot \text{m}^3/\text{kmol} \cdot \text{K})(293 \text{ K})} = \mathbf{22.87 \text{ kg}}$$

(b) To use the Amagat's law for this real gas mixture, we first need the mole fractions and the *Z* of each component at the mixture temperature and pressure.

$$y_{\text{O}_2} = \frac{N_{\text{O}_2}}{N_m} = \frac{0.003125 \text{ kmol}}{0.1509 \text{ kmol}} = 0.02071$$

$$y_{\text{CO}_2} = \frac{N_{\text{CO}_2}}{N_m} = \frac{0.02273 \text{ kmol}}{0.1509 \text{ kmol}} = 0.1506$$

$$y_{\text{He}} = \frac{N_{\text{He}}}{N_m} = \frac{0.125 \text{ kmol}}{0.1509 \text{ kmol}} = 0.8284$$

$$\left. \begin{aligned} T_{R,\text{O}_2} &= \frac{T_m}{T_{\text{cr},\text{O}_2}} = \frac{293 \text{ K}}{154.8 \text{ K}} = 1.893 \\ P_{R,\text{O}_2} &= \frac{P_m}{P_{\text{cr},\text{O}_2}} = \frac{17.5 \text{ MPa}}{5.08 \text{ MPa}} = 3.445 \end{aligned} \right\} Z_{\text{O}_2} = 0.93 \quad (\text{Fig. A-15})$$

$$\left. \begin{aligned} T_{R,\text{CO}_2} &= \frac{T_m}{T_{\text{cr},\text{CO}_2}} = \frac{293 \text{ K}}{304.2 \text{ K}} = 0.963 \\ P_{R,\text{CO}_2} &= \frac{P_m}{P_{\text{cr},\text{CO}_2}} = \frac{17.5 \text{ MPa}}{7.39 \text{ MPa}} = 2.368 \end{aligned} \right\} Z_{\text{CO}_2} = 0.33 \quad (\text{Fig. A-15})$$

$$\left. \begin{aligned} T_{R,\text{He}} &= \frac{T_m}{T_{\text{cr},\text{He}}} = \frac{293 \text{ K}}{5.3 \text{ K}} = 55.3 \\ P_{R,\text{He}} &= \frac{P_m}{P_{\text{cr},\text{He}}} = \frac{17.5 \text{ MPa}}{0.23 \text{ MPa}} = 76.1 \end{aligned} \right\} Z_{\text{He}} = 1.04 \quad (\text{from EES})$$

Then,

$$Z_m = \sum y_i Z_i = y_{O_2} Z_{O_2} + y_{CO_2} Z_{CO_2} + y_{He} Z_{He}$$

$$= (0.02071)(0.93) + (0.1506)(0.33) + (0.8284)(1.04) = 0.9305$$

$$m = \frac{M_m P V}{Z_m R_u T} = \frac{(10.61 \text{ kg/kmol})(17,500 \text{ kPa})(0.3 \text{ m}^3)}{(0.9305)(8.314 \text{ kPa} \cdot \text{m}^3/\text{kmol} \cdot \text{K})(293 \text{ K})} = \mathbf{24.57 \text{ kg}}$$

(c) To use Dalton's law with compressibility factors:

$$\left. \begin{aligned} T_{R,O_2} &= 1.893 \\ \nu_{R,O_2} &= \frac{\nu_m/m_{O_2}}{R_{O_2} T_{cr,O_2} / P_{cr,O_2}} = \frac{(0.3 \text{ m}^3)/(22.87 \times 0.1/1.6 \text{ kg})}{(0.2598 \text{ kPa} \cdot \text{m}^3/\text{kg} \cdot \text{K})(154.8 \text{ K})/(5080 \text{ kPa})} = 26.5 \end{aligned} \right\} Z_{O_2} = 1.0$$

$$\left. \begin{aligned} T_{R,CO_2} &= 0.963 \\ \nu_{R,CO_2} &= \frac{\nu_m/m_{CO_2}}{R_{CO_2} T_{cr,CO_2} / P_{cr,CO_2}} = \frac{(0.3 \text{ m}^3)/(22.87 \times 1.0/1.6 \text{ kg})}{(0.1889 \text{ kPa} \cdot \text{m}^3/\text{kg} \cdot \text{K})(304.2 \text{ K})/(7390 \text{ kPa})} = 2.70 \end{aligned} \right\} Z_{CO_2} = 0.86$$

$$\left. \begin{aligned} T_{R,He} &= 55.3 \\ \nu_{R,He} &= \frac{\nu_m/m_{He}}{R_{He} T_{cr,He} / P_{cr,He}} = \frac{(0.3 \text{ m}^3)/(22.87 \times 0.5/1.6 \text{ kg})}{(2.0769 \text{ kPa} \cdot \text{m}^3/\text{kg} \cdot \text{K})(5.3 \text{ K})/(230 \text{ kPa})} = 0.88 \end{aligned} \right\} Z_{He} = 1.0$$

Note that we used $m = 22.87 \text{ kg}$ in above calculations, the value obtained by ideal gas behavior. The solution normally requires iteration until the assumed and calculated mass values match. The mass of the component gas is obtained by multiplying the mass of the mixture by its mass fraction. Then,

$$Z_m = \sum y_i Z_i = y_{O_2} Z_{O_2} + y_{CO_2} Z_{CO_2} + y_{He} Z_{He}$$

$$= (0.02071)(1.0) + (0.1506)(0.86) + (0.8284)(1.0) = 0.9786$$

$$m = \frac{M_m P V}{Z_m R_u T} = \frac{(10.61 \text{ kg/kmol})(17,500 \text{ kPa})(0.3 \text{ m}^3)}{(0.9786)(8.314 \text{ kPa} \cdot \text{m}^3/\text{kmol} \cdot \text{K})(293 \text{ K})} = \mathbf{23.37 \text{ kg}}$$

This mass is sufficiently close to the mass value 22.87 kg. Therefore, there is no need to repeat the calculations at this calculated mass.

(d) To use Kay's rule, we need to determine the pseudo-critical temperature and pseudo-critical pressure of the mixture using the critical point properties of O_2 , CO_2 and He.

$$T'_{cr,m} = \sum y_i T_{cr,i} = y_{O_2} T_{cr,O_2} + y_{CO_2} T_{cr,CO_2} + y_{He} T_{cr,He}$$

$$= (0.02071)(154.8 \text{ K}) + (0.1506)(304.2 \text{ K}) + (0.8284)(5.3 \text{ K}) = 53.41 \text{ K}$$

$$P'_{cr,m} = \sum y_i P_{cr,i} = y_{O_2} P_{cr,O_2} + y_{CO_2} P_{cr,CO_2} + y_{He} P_{cr,He}$$

$$= (0.02071)(5.08 \text{ MPa}) + (0.1506)(7.39 \text{ MPa}) + (0.8284)(0.23 \text{ MPa}) = 1.409 \text{ MPa}$$

Then,

$$\left. \begin{aligned} T_R &= \frac{T_m}{T'_{cr,m}} = \frac{293 \text{ K}}{53.41 \text{ K}} = 5.486 \\ P_R &= \frac{P_m}{P'_{cr,m}} = \frac{17.5 \text{ MPa}}{1.409 \text{ MPa}} = 12.42 \end{aligned} \right\} Z_m = 1.194 \quad (\text{from EES})$$

$$m = \frac{M_m P V}{Z_m R_u T} = \frac{(10.61 \text{ kg/kmol})(17,500 \text{ kPa})(0.3 \text{ m}^3)}{(1.194)(8.314 \text{ kPa} \cdot \text{m}^3/\text{kmol} \cdot \text{K})(293 \text{ K})} = \mathbf{19.15 \text{ kg}}$$

13-89 A gas mixture is heated during a steady-flow process. The heat transfer is to be determined using two approaches.

Assumptions 1 Steady flow conditions exist. **2** Kinetic and potential energy changes are negligible.

Analysis Noting that there is no work involved, the energy balance for this gas mixture can be written, on a unit mole basis, as

$$\dot{E}_{\text{in}} - \dot{E}_{\text{out}} = \Delta \dot{E}_{\text{system}} \stackrel{\text{no (steady)}}{=} 0$$

$$\dot{E}_{\text{in}} = \dot{E}_{\text{out}}$$

$$\bar{q}_{\text{in}} + \bar{h}_1 = \bar{h}_2$$

$$\bar{q}_{\text{in}} = \Delta \bar{h}$$

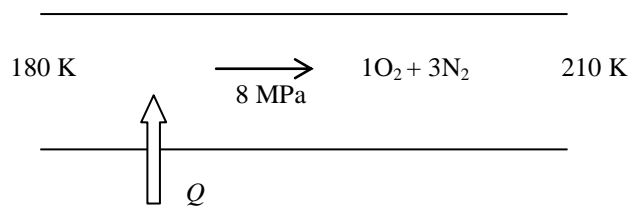

Also,

$$y_{\text{O}_2} = 0.25 \quad \text{and} \quad y_{\text{N}_2} = 0.75.$$

(a) Assuming ideal gas behavior, the inlet and exit enthalpies of O_2 and N_2 are determined from the ideal gas tables to be

$$\text{O}_2 : h_1 = h_{@180\text{K}} = 5239.6 \text{ kJ/kmol}, \quad h_2 = h_{@210\text{K}} = 6112.9 \text{ kJ/kmol}$$

$$\text{N}_2 : h_1 = h_{@180\text{K}} = 5229 \text{ kJ/kmol}, \quad h_2 = h_{@210\text{K}} = 6,100.5 \text{ kJ/kmol}$$

Thus,

$$\begin{aligned} \bar{q}_{\text{in,ideal}} &= \sum y_i \Delta \bar{h}_i = y_{\text{O}_2} (\bar{h}_2 - \bar{h}_1)_{\text{O}_2} + y_{\text{N}_2} (\bar{h}_2 - \bar{h}_1)_{\text{N}_2} \\ &= (0.25)(6,112.9 - 5,239.6) + (0.75)(6,100.5 - 5,229) \\ &= \mathbf{872.0 \text{ kJ/kmol}} \end{aligned}$$

(b) Using the Kay's rule, the gas mixture can be treated as a pseudo-pure substance whose critical temperature and pressure are

$$\begin{aligned} T'_{\text{cr,m}} &= \sum y_i T_{\text{cr},i} = y_{\text{O}_2} T_{\text{cr,O}_2} + y_{\text{N}_2} T_{\text{cr,N}_2} \\ &= (0.25)(154.8 \text{ K}) + (0.75)(126.2 \text{ K}) \\ &= 133.4 \text{ K} \end{aligned}$$

$$\begin{aligned} P'_{\text{cr,m}} &= \sum y_i P_{\text{cr},i} = y_{\text{O}_2} P_{\text{cr,O}_2} + y_{\text{N}_2} P_{\text{cr,N}_2} \\ &= (0.25)(5.08 \text{ MPa}) + (0.75)(3.39 \text{ MPa}) \\ &= 3.81 \text{ MPa} \end{aligned}$$

Then,

$$\left. \begin{aligned} T_{R,1} &= \frac{T_{m,1}}{T_{\text{cr,m}}} = \frac{180}{133.4} = 1.349 \\ P_{R,1} &= P_{R,2} = \frac{P_m}{P_{\text{cr,m}}} = \frac{8}{3.81} = 2.100 \\ T_{R,2} &= \frac{T_{m,2}}{T_{\text{cr,m}}} = \frac{210}{133.4} = 1.574 \end{aligned} \right\} \begin{aligned} Z_{h_1} &= 1.4 \\ Z_{h_2} &= 1.1 \end{aligned} \quad (\text{Fig. A-29})$$

The heat transfer in this case is determined from

$$\begin{aligned} \bar{q}_{\text{in}} &= \bar{h}_2 - \bar{h}_1 = R_u T_{\text{cr}} (Z_{h_1} - Z_{h_2}) + (\bar{h}_2 - \bar{h}_1)_{\text{ideal}} \\ &= R_u T_{\text{cr}} (Z_{h_1} - Z_{h_2}) + \bar{q}_{\text{ideal}} \\ &= (8.314 \text{ kJ/kmol} \cdot \text{K})(133.4 \text{ K})(1.4 - 1.1) + (872 \text{ kJ/kmol}) \\ &= \mathbf{1205 \text{ kJ/kmol}} \end{aligned}$$



13-90 Problem 13-89 is reconsidered. The effect of the mole fraction of oxygen in the mixture on heat transfer using real gas behavior with EES data is to be investigated.

Analysis The problem is solved using EES, and the solution is given below.

"Input Data:"

$y_{N_2}/y_{O_2} = 3$

$T[1] = 180$ [K] "Inlet temperature"

$T[2] = 210$ [K] "Exit temperature"

$P = 8000$ [kPa]

$R_u = 8.34$ [kJ/kmol-K]

"Solution is done on a unit mole of mixture basis:"

$y_{N_2} + y_{O_2} = 1$

$\Delta e_{bar_sys} = 0$ "Steady-flow analysis for all cases"

"Ideal gas:"

$e_{bar_in_IG} - e_{bar_out_IG} = \Delta e_{bar_sys}$

$e_{bar_in_IG} = q_{bar_in_IG} + h_{bar_1_IG}$

$e_{bar_out_IG} = h_{bar_2_IG}$

$h_{bar_1_IG} = y_{N_2} \cdot \text{enthalpy}(N_2, T=T[1]) + y_{O_2} \cdot \text{enthalpy}(O_2, T=T[1])$

$h_{bar_2_IG} = y_{N_2} \cdot \text{enthalpy}(N_2, T=T[2]) + y_{O_2} \cdot \text{enthalpy}(O_2, T=T[2])$

"EES:"

$P_{N_2} = y_{N_2} \cdot P$

$P_{O_2} = y_{O_2} \cdot P$

$e_{bar_in_EES} - e_{bar_out_EES} = \Delta e_{bar_sys}$

$e_{bar_in_EES} = q_{bar_in_EES} + h_{bar_1_EES}$

$e_{bar_out_EES} = h_{bar_2_EES}$

$h_{bar_1_EES} = y_{N_2} \cdot \text{enthalpy}(\text{Nitrogen}, T=T[1], P=P_{N_2}) + y_{O_2} \cdot \text{enthalpy}(\text{Oxygen}, T=T[1], P=P_{O_2})$

$h_{bar_2_EES} = y_{N_2} \cdot \text{enthalpy}(\text{Nitrogen}, T=T[2], P=P_{N_2}) + y_{O_2} \cdot \text{enthalpy}(\text{Oxygen}, T=T[2], P=P_{O_2})$

"Kay's Rule:"

$T_{cr_N_2} = 126.2$ [K] "Table A.1"

$T_{cr_O_2} = 154.8$ [K]

$P_{cr_N_2} = 3390$ [kPa] "Table A.1"

$P_{cr_O_2} = 5080$ [kPa]

$T_{cr_mix} = y_{N_2} \cdot T_{cr_N_2} + y_{O_2} \cdot T_{cr_O_2}$

$P_{cr_mix} = y_{N_2} \cdot P_{cr_N_2} + y_{O_2} \cdot P_{cr_O_2}$

$e_{bar_in_Zchart} - e_{bar_out_Zchart} = \Delta e_{bar_sys}$

$e_{bar_in_Zchart} = q_{bar_in_Zchart} + h_{bar_1_Zchart}$

$e_{bar_out_Zchart} = h_{bar_2_Zchart}$

"State 1 by compressability chart"

$Tr[1] = T[1]/T_{cr_mix}$

$Pr[1] = P/P_{cr_mix}$

$\Delta h_{bar_1} = \text{ENTHDEP}(Tr[1], Pr[1]) \cdot R_u \cdot T_{cr_mix}$ "Enthalpy departure"

$h_{bar_1_Zchart} = h_{bar_1_IG} - \Delta h_{bar_1}$ "Enthalpy of real gas using charts"

"State 2 by compressability chart"

$Tr[2] = T[2]/T_{cr_mix}$

$Pr[2] = Pr[1]$

$\Delta h_{bar_2} = \text{ENTHDEP}(Tr[2], Pr[2]) \cdot R_u \cdot T_{cr_mix}$ "Enthalpy departure"

$h_{bar_2_Zchart} = h_{bar_2_IG} - \Delta h_{bar_2}$ "Enthalpy of real gas using charts"

q_{inEES} [kJ/kmol]	q_{inIG} [kJ/kmol]	$q_{inZchart}$ [kJ/kmol]	y_{O_2}
1320	659.6	1139	0.01
1241	693.3	1193	0.1
1171	730.7	1255	0.2
1144	749.4	1287	0.25
1123	768.1	1320	0.3
1099	805.5	1387	0.4
1105	842.9	1459	0.5
1144	880.3	1534	0.6
1221	917.7	1615	0.7
1343	955.2	1702	0.8
1518	992.6	1797	0.9
1722	1026	1892	0.99

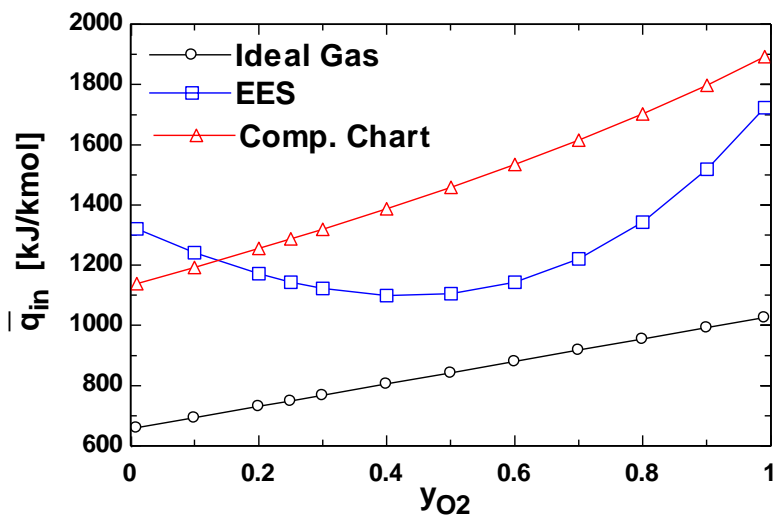

13-91 A gas mixture is heated during a steady-flow process, as discussed in the previous problem. The total entropy change and the exergy destruction are to be determined using two methods.

Analysis The entropy generated during this process is determined by applying the entropy balance on an *extended system* that includes the piston-cylinder device and its immediate surroundings so that the boundary temperature of the extended system is the environment temperature at all times. It gives

$$S_{\text{in}} - S_{\text{out}} + S_{\text{gen}} = \Delta S_{\text{system}}$$

$$\frac{Q_{\text{in}}}{T_{\text{boundary}}} + S_{\text{gen}} = \Delta S_{\text{system}} \rightarrow S_{\text{gen}} = m(s_2 - s_1) - \frac{Q_{\text{in}}}{T_{\text{surr}}}$$

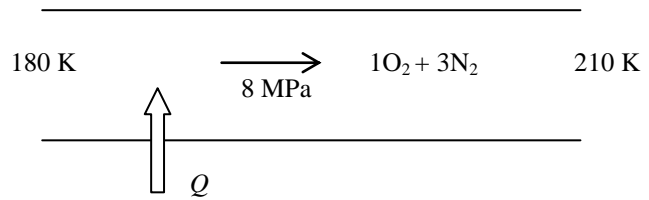

Then the exergy destroyed during a process can be determined from its definition $X_{\text{destroyed}} = T_0 S_{\text{gen}}$.

(a) Noting that the total mixture pressure, and thus the partial pressure of each gas, remains constant, the entropy change of a component in the mixture during this process is

$$\Delta \bar{s}_i = \left(\bar{c}_p \ln \frac{T_2}{T_1} - R_u \ln \frac{P_2}{P_1} \right)_i = M c_p \ln \frac{T_2}{T_1}$$

Assuming ideal gas behavior and c_p values at room temperature (Table A-2), the $\Delta \bar{s}$ of O_2 and N_2 are determined from

$$\Delta \bar{s}_{O_2, \text{ideal}} = (32 \text{ kg/kmol})(0.918 \text{ kJ/kg} \cdot \text{K}) \ln \frac{210 \text{ K}}{180 \text{ K}} = 4.52 \text{ kJ/kmol} \cdot \text{K}$$

$$\Delta \bar{s}_{N_2, \text{ideal}} = (28 \text{ kg/kmol})(1.039 \text{ kJ/kg} \cdot \text{K}) \ln \frac{210 \text{ K}}{180 \text{ K}} = 4.48 \text{ kJ/kmol} \cdot \text{K}$$

$$\begin{aligned} \Delta \bar{s}_{\text{sys ideal}} &= \sum y_i \Delta \bar{s}_i = y_{O_2} \Delta \bar{s}_{O_2} + y_{N_2} \Delta \bar{s}_{N_2} \\ &= (0.25)(4.52 \text{ kJ/kmol} \cdot \text{K}) + (0.75)(4.48 \text{ kJ/kmol} \cdot \text{K}) \\ &= 4.49 \text{ kJ/kmol} \cdot \text{K} \end{aligned}$$

and

$$\bar{s}_{\text{gen}} = 4.49 \text{ kJ/kmol} \cdot \text{K} - \frac{872 \text{ kJ/kmol}}{303 \text{ K}} = \mathbf{1.61 \text{ kJ/kmol} \cdot \text{K}}$$

$$\bar{x}_{\text{destroyed}} = T_0 \bar{s}_{\text{gen}} = (303 \text{ K})(1.61 \text{ kJ/kmol} \cdot \text{K}) = \mathbf{488 \text{ kJ/kmol}}$$

(b) Using the Kay's rule, the gas mixture can be treated as a pseudo-pure substance whose critical temperature and pressure are

$$\begin{aligned} T'_{\text{cr}, m} &= \sum y_i T_{\text{cr}, i} = y_{O_2} T_{\text{cr}, O_2} + y_{N_2} T_{\text{cr}, N_2} \\ &= (0.25)(154.8 \text{ K}) + (0.75)(126.2 \text{ K}) \\ &= 133.4 \text{ K} \end{aligned}$$

$$\begin{aligned} P'_{\text{cr}, m} &= \sum y_i P_{\text{cr}, i} = y_{O_2} P_{\text{cr}, O_2} + y_{N_2} P_{\text{cr}, N_2} \\ &= (0.25)(5.08 \text{ MPa}) + (0.75)(3.39 \text{ MPa}) \\ &= 3.81 \text{ MPa} \end{aligned}$$

Then,

$$\left. \begin{aligned} T_{R,1} &= \frac{T_{m,1}}{T_{cr,m}} = \frac{180}{133.4} = 1.349 \\ P_{R,1} &= P_{R,2} = \frac{P_m}{P_{cr,m}} = \frac{8}{3.81} = 2.100 \\ T_{R,2} &= \frac{T_{m,2}}{T_{cr,m}} = \frac{210}{133.4} = 1.574 \end{aligned} \right\} \begin{aligned} Z_{s_1} &= 0.8 \\ Z_{s_2} &= 0.45 \end{aligned} \quad (\text{Fig. A-30})$$

Thus,

$$\begin{aligned} \Delta \bar{s}_{\text{sys}} &= R_u (Z_{s_1} - Z_{s_2}) + \Delta \bar{s}_{\text{sys ideal}} \\ &= (8.314 \text{ kJ/kmol} \cdot \text{K})(0.8 - 0.45) + (4.49 \text{ kJ/kmol} \cdot \text{K}) \\ &= 7.40 \text{ kJ/kmol} \cdot \text{K} \end{aligned}$$

and

$$\begin{aligned} \bar{s}_{gen} &= 7.40 \text{ kJ/kmol} \cdot \text{K} - \frac{1204.7 \text{ kJ/kmol}}{303 \text{ K}} = \mathbf{3.41 \text{ kJ/kmol} \cdot \text{K}} \\ \bar{x}_{\text{destroyed}} &= T_0 \bar{s}_{gen} = (303 \text{ K})(3.41 \text{ kJ/kmol} \cdot \text{K}) = \mathbf{1034 \text{ kJ/kmol}} \end{aligned}$$

13-92 The specific heat ratio and an apparent molecular weight of a mixture of ideal gases are given. The work required to compress this mixture isentropically in a closed system is to be determined.

Analysis For an isentropic process of an ideal gas with constant specific heats, the work is expressed as

$$w_{\text{out}} = \int_1^2 P d\nu = P_1 \nu_1^k \int_1^2 \nu^{-k} d\nu$$

$$= \frac{P_1 \nu_1^k}{1-k} (\nu_2^{1-k} - \nu_1^{1-k}) = \frac{P_1 \nu_1^k}{1-k} \left[\left(\frac{\nu_2}{\nu_1} \right)^{1-k} - 1 \right]$$

since $P_1 \nu_1^k = P \nu^k$ for an isentropic process. Also,

$$P_1 \nu_1 = RT_1$$

$$(\nu_2 / \nu_1)^k = P_1 / P_2$$

Substituting, we obtain

$$w_{\text{out}} = \frac{R_u T_1}{M(1-k)} \left[\left(\frac{P_2}{P_1} \right)^{(k-1)/k} - 1 \right]$$

$$= \frac{(8.314 \text{ kJ/kmol} \cdot \text{K})(288 \text{ K})}{(32 \text{ kg/kmol})(1-1.35)} \left[\left(\frac{700 \text{ kPa}}{100 \text{ kPa}} \right)^{(1.35-1)/1.35} - 1 \right]$$

$$= \mathbf{-140 \text{ kJ/kg}}$$

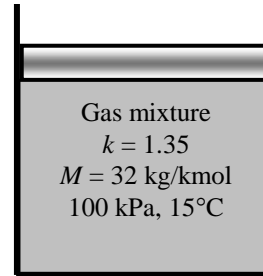

The negative sign shows that the work is done on the system.

13-93 A mixture of gases is placed in a spring-loaded piston-cylinder device. The device is now heated until the pressure rises to a specified value. The total work and heat transfer for this process are to be determined.

Properties The molar masses of Ne, O₂, and N₂ are 20.18, 32.0, 28.0 kg/kmol, respectively and the gas constants are 0.4119, 0.2598, and 0.2968 kJ/kg·K, respectively (Table A-1). The constant-volume specific heats are 0.6179, 0.658, and 0.743 kJ/kg·K, respectively (Table A-2a).

Analysis The total pressure is 200 kPa and the partial pressures are

$$P_{\text{Ne}} = y_{\text{Ne}} P_m = (0.25)(200 \text{ kPa}) = 50 \text{ kPa}$$

$$P_{\text{O}_2} = y_{\text{O}_2} P_m = (0.50)(200 \text{ kPa}) = 100 \text{ kPa}$$

$$P_{\text{N}_2} = y_{\text{N}_2} P_m = (0.25)(200 \text{ kPa}) = 50 \text{ kPa}$$

The mass of each constituent for a volume of 0.1 m³ and a temperature of 10°C are

$$m_{\text{Ne}} = \frac{P_{\text{Ne}} V_m}{R_{\text{Ne}} T} = \frac{(50 \text{ kPa})(0.1 \text{ m}^3)}{(0.4119 \text{ kPa} \cdot \text{m}^3/\text{kg} \cdot \text{K})(283 \text{ K})} = 0.04289 \text{ kg}$$

$$m_{\text{O}_2} = \frac{P_{\text{O}_2} V_m}{R_{\text{O}_2} T} = \frac{(100 \text{ kPa})(0.1 \text{ m}^3)}{(0.2598 \text{ kPa} \cdot \text{m}^3/\text{kg} \cdot \text{K})(283 \text{ K})} = 0.1360 \text{ kg}$$

$$m_{\text{N}_2} = \frac{P_{\text{N}_2} V_m}{R_{\text{N}_2} T} = \frac{(50 \text{ kPa})(0.1 \text{ m}^3)}{(0.2968 \text{ kPa} \cdot \text{m}^3/\text{kg} \cdot \text{K})(283 \text{ K})} = 0.05953 \text{ kg}$$

$$m_{\text{total}} = 0.04289 + 0.1360 + 0.05953 = 0.2384 \text{ kg}$$

The mass fractions are

$$\text{mf}_{\text{Ne}} = \frac{m_{\text{Ne}}}{m_m} = \frac{0.04289 \text{ kg}}{0.2384 \text{ kg}} = 0.1799$$

$$\text{mf}_{\text{O}_2} = \frac{m_{\text{O}_2}}{m_m} = \frac{0.1360 \text{ kg}}{0.2384 \text{ kg}} = 0.5705$$

$$\text{mf}_{\text{N}_2} = \frac{m_{\text{N}_2}}{m_m} = \frac{0.05953 \text{ kg}}{0.2384 \text{ kg}} = 0.2497$$

The constant-volume specific heat of the mixture is determined from

$$\begin{aligned} c_v &= \text{mf}_{\text{Ne}} c_{v,\text{Ne}} + \text{mf}_{\text{O}_2} c_{v,\text{O}_2} + \text{mf}_{\text{N}_2} c_{v,\text{N}_2} \\ &= 0.1799 \times 0.6179 + 0.5705 \times 0.658 + 0.2497 \times 0.743 \\ &= 0.672 \text{ kJ/kg} \cdot \text{K} \end{aligned}$$

The moles are

$$N_{\text{Ne}} = \frac{m_{\text{Ne}}}{M_{\text{Ne}}} = \frac{0.04289 \text{ kg}}{20.18 \text{ kg/kmol}} = 0.002126 \text{ kmol}$$

$$N_{\text{O}_2} = \frac{m_{\text{O}_2}}{M_{\text{O}_2}} = \frac{0.1360 \text{ kg}}{32 \text{ kg/kmol}} = 0.00425 \text{ kmol}$$

$$N_{\text{N}_2} = \frac{m_{\text{N}_2}}{M_{\text{N}_2}} = \frac{0.05953 \text{ kg}}{28 \text{ kg/kmol}} = 0.002126 \text{ kmol}$$

$$N_m = N_{\text{Ne}} + N_{\text{O}_2} + N_{\text{N}_2} = 0.008502 \text{ kmol}$$

Then the apparent molecular weight of the mixture becomes

$$M_m = \frac{m_m}{N_m} = \frac{0.2384 \text{ kg}}{0.008502 \text{ kmol}} = 28.04 \text{ kg/kmol}$$

The apparent gas constant of the mixture is

$$R = \frac{R_u}{M_m} = \frac{8.314 \text{ kJ/kmol} \cdot \text{K}}{28.05 \text{ kg/kmol}} = 0.2964 \text{ kJ/kg} \cdot \text{K}$$

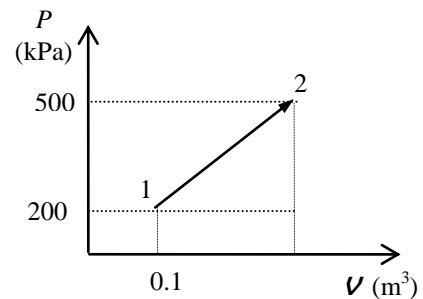
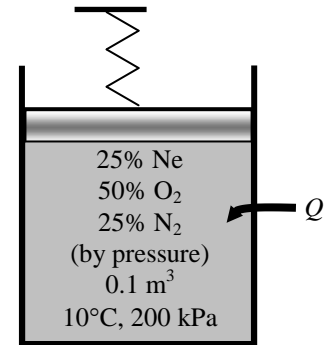

The mass contained in the system is

$$m = \frac{P_1 \mathcal{V}_1}{RT_1} = \frac{(200 \text{ kPa})(0.1 \text{ m}^3)}{(0.2964 \text{ kPa} \cdot \text{m}^3/\text{kg} \cdot \text{K})(283 \text{ K})} = 0.2384 \text{ kg}$$

Noting that the pressure changes linearly with volume, the final volume is determined by linear interpolation to be

$$\frac{500 - 200}{1000 - 200} = \frac{\mathcal{V}_2 - 0.1}{1.0 - 0.1} \longrightarrow \mathcal{V}_2 = 0.4375 \text{ m}^3$$

The final temperature is

$$T_2 = \frac{P_2 \mathcal{V}_2}{mR} = \frac{(500 \text{ kPa})(0.4375 \text{ m}^3)}{(0.2384 \text{ kg})(0.2964 \text{ kPa} \cdot \text{m}^3/\text{kg} \cdot \text{K})} = 3096 \text{ K}$$

The work done during this process is

$$W_{\text{out}} = \frac{P_1 + P_2}{2} (\mathcal{V}_2 - \mathcal{V}_1) = \frac{(500 + 200) \text{ kPa}}{2} (0.4375 - 0.1) \text{ m}^3 = \mathbf{118 \text{ kJ}}$$

An energy balance on the system gives

$$Q_{\text{in}} = W_{\text{out}} + mc_v(T_2 - T_1) = 118 + (0.2384 \text{ kg})(0.672 \text{ kJ/kg} \cdot \text{K})(3096 - 283) \text{ K} = \mathbf{569 \text{ kJ}}$$

13-94 A spring-loaded piston-cylinder device is filled with a mixture of nitrogen and carbon dioxide whose mass fractions are given. The gas is heated until the volume has doubled. The total work and heat transfer for this process are to be determined.

Properties The molar masses of N_2 and CO_2 are 28.0 and 44.0 kg/kmol, respectively (Table A-1). The constant-volume specific heats of these gases at room temperature are 0.743 and 0.657 kJ/kg·K, respectively (Table A-2a).

Analysis We consider 100 kg of this mixture. The mole numbers of each component are

$$N_{N_2} = \frac{m_{N_2}}{M_{N_2}} = \frac{55 \text{ kg}}{28 \text{ kg/kmol}} = 1.964 \text{ kmol}$$

$$N_{CO_2} = \frac{m_{CO_2}}{M_{CO_2}} = \frac{45 \text{ kg}}{44 \text{ kg/kmol}} = 1.023 \text{ kmol}$$

The mole number of the mixture is

$$N_m = N_{N_2} + N_{CO_2} = 1.964 + 1.023 = 2.987 \text{ kmol}$$

The apparent molecular weight of the mixture is

$$M_m = \frac{m_m}{N_m} = \frac{100 \text{ kg}}{2.987 \text{ kmol}} = 33.48 \text{ kg/kmol}$$

The constant-volume specific heat of the mixture is determined from

$$c_v = mf_{N_2}c_{v,N_2} + mf_{CO_2}c_{v,CO_2} = 0.55 \times 0.743 + 0.45 \times 0.657 = 0.7043 \text{ kJ/kg} \cdot \text{K}$$

The apparent gas constant of the mixture is

$$R = \frac{R_u}{M_m} = \frac{8.134 \text{ kJ/kmol} \cdot \text{K}}{33.48 \text{ kg/kmol}} = 0.2483 \text{ kJ/kg} \cdot \text{K}$$

Noting that the pressure changes linearly with volume, the initial volume is determined by linear interpolation using the data of the previous problem to be

$$\frac{200 - 200}{1000 - 200} = \frac{V_1 - 0.1}{1.0 - 0.1} \longrightarrow V_1 = 0.1 \text{ m}^3$$

The final volume is

$$V_2 = 2V_1 = 2(0.1 \text{ m}^3) = 0.2 \text{ m}^3$$

The final pressure is similarly determined by linear interpolation using the data of the previous problem to be

$$\frac{P_2 - 200}{1000 - 200} = \frac{0.2 - 0.1}{1.0 - 0.1} \longrightarrow P_2 = 288.9 \text{ kPa}$$

The mass contained in the system is

$$m = \frac{P_1 V_1}{RT_1} = \frac{(200 \text{ kPa})(0.1 \text{ m}^3)}{(0.2483 \text{ kPa} \cdot \text{m}^3/\text{kg} \cdot \text{K})(318 \text{ K})} = 0.2533 \text{ kg}$$

The final temperature is

$$T_2 = \frac{P_2 V_2}{mR} = \frac{(288.9 \text{ kPa})(0.2 \text{ m}^3)}{(0.2533 \text{ kg})(0.2483 \text{ kPa} \cdot \text{m}^3/\text{kg} \cdot \text{K})} = 918.7 \text{ K}$$

The work done during this process is

$$W_{\text{out}} = \frac{P_1 + P_2}{2} (V_2 - V_1) = \frac{(200 + 288.9) \text{ kPa}}{2} (0.2 - 0.1) \text{ m}^3 = \mathbf{24.4 \text{ kJ}}$$

An energy balance on the system gives

$$Q_{\text{in}} = W_{\text{out}} + mc_v(T_2 - T_1) = 24.4 + (0.2533 \text{ kg})(0.7043 \text{ kJ/kg} \cdot \text{K})(918.7 - 318) \text{ K} = \mathbf{132 \text{ kJ}}$$

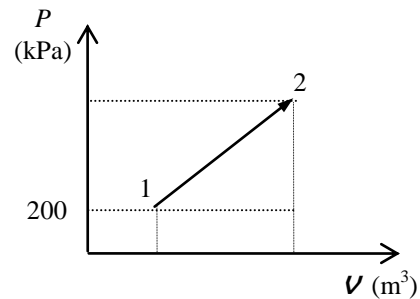
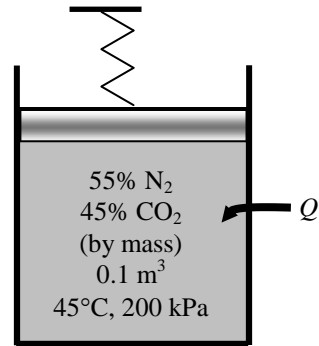

13-95 A spring-loaded piston-cylinder device is filled with a mixture of nitrogen and carbon dioxide whose mass fractions are given. The gas is heated until the pressure has tripled. The total work and heat transfer for this process are to be determined.

Properties The molar masses of N_2 and CO_2 are 28.0 and 44.0 kg/kmol, respectively (Table A-1). The constant-volume specific heats of these gases at room temperature are 0.743 and 0.657 kJ/kg·K, respectively (Table A-2a).

Analysis We consider 100 kg of this mixture. The mole numbers of each component are

$$N_{N_2} = \frac{m_{N_2}}{M_{N_2}} = \frac{55 \text{ kg}}{28 \text{ kg/kmol}} = 1.964 \text{ kmol}$$

$$N_{CO_2} = \frac{m_{CO_2}}{M_{CO_2}} = \frac{45 \text{ kg}}{44 \text{ kg/kmol}} = 1.023 \text{ kmol}$$

The mole number of the mixture is

$$N_m = N_{N_2} + N_{CO_2} = 1.964 + 1.023 = 2.987 \text{ kmol}$$

The apparent molecular weight of the mixture is

$$M_m = \frac{m_m}{N_m} = \frac{100 \text{ kg}}{2.987 \text{ kmol}} = 33.48 \text{ kg/kmol}$$

The constant-volume specific heat of the mixture is determined from

$$c_v = mf_{N_2}c_{v,N_2} + mf_{CO_2}c_{v,CO_2} = 0.55 \times 0.743 + 0.45 \times 0.657 = 0.7043 \text{ kJ/kg} \cdot \text{K}$$

The apparent gas constant of the mixture is

$$R = \frac{R_u}{M_m} = \frac{8.134 \text{ kJ/kmol} \cdot \text{K}}{33.48 \text{ kg/kmol}} = 0.2483 \text{ kJ/kg} \cdot \text{K}$$

Noting that the pressure changes linearly with volume, the initial volume is determined by linear interpolation using the data of the previous problem to be

$$\frac{200 - 200}{1000 - 200} = \frac{V_1 - 0.1}{1.0 - 0.1} \rightarrow V_1 = 0.1 \text{ m}^3$$

The final pressure is

$$P_2 = 3P_1 = 3(200 \text{ kPa}) = 600 \text{ kPa}$$

The final volume is similarly determined by linear interpolation using the data of the previous problem to be

$$\frac{600 - 200}{1000 - 200} = \frac{V_2 - 0.1}{1.0 - 0.1} \rightarrow V_2 = 0.55 \text{ m}^3$$

The mass contained in the system is

$$m = \frac{P_1 V_1}{RT_1} = \frac{(200 \text{ kPa})(0.1 \text{ m}^3)}{(0.2483 \text{ kPa} \cdot \text{m}^3/\text{kg} \cdot \text{K})(318 \text{ K})} = 0.2533 \text{ kg}$$

The final temperature is

$$T_2 = \frac{P_2 V_2}{mR} = \frac{(600 \text{ kPa})(0.55 \text{ m}^3)}{(0.2533 \text{ kg})(0.2483 \text{ kPa} \cdot \text{m}^3/\text{kg} \cdot \text{K})} = 5247 \text{ K}$$

The work done during this process is

$$W_{\text{out}} = \frac{P_1 + P_2}{2} (V_2 - V_1) = \frac{(200 + 600) \text{ kPa}}{2} (0.55 - 0.1) \text{ m}^3 = \mathbf{180 \text{ kJ}}$$

An energy balance on the system gives

$$Q_{\text{in}} = W_{\text{out}} + mc_v(T_2 - T_1) = 180 + (0.2533 \text{ kg})(0.7043 \text{ kJ/kg} \cdot \text{K})(5247 - 318) \text{ K} = \mathbf{1059 \text{ kJ}}$$

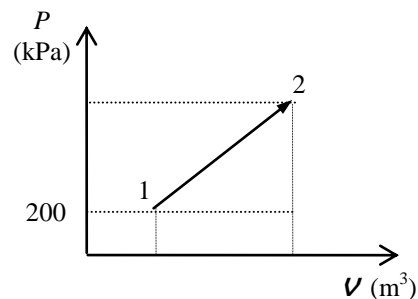
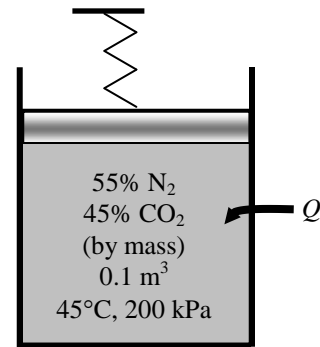

13-96 The masses, pressures, and temperatures of the constituents of a gas mixture in a tank are given. Heat is transferred to the tank. The final pressure of the mixture and the heat transfer are to be determined.

Assumptions He is an ideal gas and O₂ is a nonideal gas.

Properties The molar masses of He and O₂ are 4.0 and 32.0 kg/kmol. (Table A-1)

Analysis (a) The number of moles of each gas is

$$N_{\text{He}} = \frac{m_{\text{He}}}{M_{\text{He}}} = \frac{4 \text{ kg}}{4.0 \text{ kg/kmol}} = 1 \text{ kmol}$$

$$N_{\text{O}_2} = \frac{m_{\text{O}_2}}{M_{\text{O}_2}} = \frac{8 \text{ kg}}{32 \text{ kg/kmol}} = 0.25 \text{ kmol}$$

$$N_m = N_{\text{He}} + N_{\text{O}_2} = 1 \text{ kmol} + 0.25 \text{ kmol} = 1.25 \text{ kmol}$$

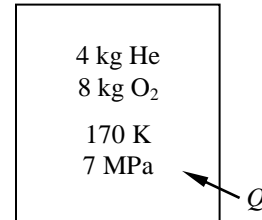

Then the partial volume of each gas and the volume of the tank are

He:

$$V_{\text{He}} = \frac{N_{\text{He}} R_u T_1}{P_{m,1}} = \frac{(1 \text{ kmol})(8.314 \text{ kPa} \cdot \text{m}^3/\text{kmol} \cdot \text{K})(170 \text{ K})}{7000 \text{ kPa}} = 0.202 \text{ m}^3$$

O₂:

$$\left. \begin{aligned} P_{R_1} &= \frac{P_{m,1}}{P_{\text{cr},\text{O}_2}} = \frac{7}{5.08} = 1.38 \\ T_{R_1} &= \frac{T_1}{T_{\text{cr},\text{O}_2}} = \frac{170}{154.8} = 1.10 \end{aligned} \right\} Z_1 = 0.53 \quad (\text{Fig. A-15})$$

$$V_{\text{O}_2} = \frac{Z N_{\text{O}_2} R_u T_1}{P_{m,1}} = \frac{(0.53)(0.25 \text{ kmol})(8.314 \text{ kPa} \cdot \text{m}^3/\text{kg} \cdot \text{K})(170 \text{ K})}{7000 \text{ kPa}} = 0.027 \text{ m}^3$$

$$V_{\text{tank}} = V_{\text{He}} + V_{\text{O}_2} = 0.202 \text{ m}^3 + 0.027 \text{ m}^3 = 0.229 \text{ m}^3$$

The partial pressure of each gas and the total final pressure is

He:

$$P_{\text{He},2} = \frac{N_{\text{He}} R_u T_2}{V_{\text{tank}}} = \frac{(1 \text{ kmol})(8.314 \text{ kPa} \cdot \text{m}^3/\text{kmol} \cdot \text{K})(220 \text{ K})}{0.229 \text{ m}^3} = 7987 \text{ kPa}$$

O₂:

$$\left. \begin{aligned} T_{R_2} &= \frac{T_2}{T_{\text{cr},\text{O}_2}} = \frac{220}{154.8} = 1.42 \\ v_{R,\text{O}_2} &= \frac{\bar{v}_{\text{O}_2}}{R_u T_{\text{cr},\text{O}_2} / P_{\text{cr},\text{O}_2}} = \frac{V_m / N_{\text{O}_2}}{R_u T_{\text{cr},\text{O}_2} / P_{\text{cr},\text{O}_2}} \\ &= \frac{(0.229 \text{ m}^3)/(0.25 \text{ kmol})}{(8.314 \text{ kPa} \cdot \text{m}^3/\text{kmol} \cdot \text{K})(154.8 \text{ K})/(5080 \text{ kPa})} = 3.616 \end{aligned} \right\} P_R = 0.39 \quad (\text{Fig. A-15})$$

$$P_{\text{O}_2} = (P_R P_{\text{cr}})_{\text{O}_2} = (0.39)(5080 \text{ kPa}) = 1981 \text{ kPa} = 1.981 \text{ MPa}$$

$$P_{m,2} = P_{\text{He}} + P_{\text{O}_2} = 7.987 \text{ MPa} + 1.981 \text{ MPa} = \mathbf{9.97 \text{ MPa}}$$

(b) We take both gases as the system. No work or mass crosses the system boundary, therefore this is a closed system with no work interactions. Then the energy balance for this closed system reduces to

$$E_{\text{in}} - E_{\text{out}} = \Delta E_{\text{system}}$$

$$Q_{\text{in}} = \Delta U = \Delta U_{\text{He}} + \Delta U_{\text{O}_2}$$

He:

$$\Delta U_{\text{He}} = mc_v(T_m - T_1) = (4 \text{ kg})(3.1156 \text{ kJ/kg} \cdot \text{K})(220 - 170)\text{K} = 623.1 \text{ kJ}$$

O₂:

$$\left. \begin{array}{l} T_{R_1} = 1.10 \\ P_{R_1} = 1.38 \end{array} \right\} Z_{h_1} = 2.2$$

$$\left. \begin{array}{l} T_{R_2} = 1.42 \\ P_{R_2} = \frac{9.97}{5.08} = 1.963 \end{array} \right\} Z_{h_2} = 1.2 \quad (\text{Fig. A-29})$$

$$\begin{aligned} \bar{h}_2 - \bar{h}_1 &= R_u T_{\text{cr}} (Z_{h_1} - Z_{h_2}) + (\bar{h}_2 - \bar{h}_1)_{\text{ideal}} \\ &= (8.314 \text{ kJ/kmol} \cdot \text{K})(154.8 \text{ K})(2.2 - 1.2) + (6404 - 4949) \text{ kJ/kmol} \\ &= 2742 \text{ kJ/kmol} \end{aligned}$$

Also,

$$P_{\text{He},1} = \frac{N_{\text{He}} R_u T_1}{V_{\text{tank}}} = \frac{(1 \text{ kmol})(8.314 \text{ kPa} \cdot \text{m}^3/\text{kg} \cdot \text{K})(170 \text{ K})}{0.229 \text{ m}^3} = 6,172 \text{ kPa}$$

$$P_{\text{O}_2,1} = P_{m,1} - P_{\text{He},1} = 7000 \text{ kPa} - 6172 \text{ kPa} = 828 \text{ kPa}$$

Thus,

$$\begin{aligned} \Delta U_{\text{O}_2} &= N_{\text{O}_2} (\bar{h}_2 - \bar{h}_1) - (P_2 V_2 - P_1 V_1) = N_{\text{O}_2} (\bar{h}_2 - \bar{h}_1) - (P_{\text{O}_2,2} - P_{\text{O}_2,1}) V_{\text{tank}} \\ &= (0.25 \text{ kmol})(2742 \text{ kJ/kmol}) - (1981 - 828)(0.229) \text{ kPa} \cdot \text{m}^3 \\ &= 421.5 \text{ kJ} \end{aligned}$$

Substituting,

$$Q_{\text{in}} = 623.1 \text{ kJ} + 421.5 \text{ kJ} = \mathbf{1045 \text{ kJ}}$$

13-97E The mass percentages of a gas mixture are given. This mixture is expanded in an adiabatic, steady-flow turbine of specified isentropic efficiency. The second law efficiency and the exergy destruction during this expansion process are to be determined.

Assumptions All gases will be modeled as ideal gases with constant specific heats.

Properties The molar masses of N_2 , He, CH_4 , and C_2H_6 are 28.0, 4.0, 16.0, and 30.0 lbm/lbmol, respectively (Table A-1E). The constant-pressure specific heats of these gases at room temperature are 0.248, 1.25, 0.532, and 0.427 Btu/lbm·R, respectively (Table A-2Ea).

Analysis For 1 lbm of mixture, the mole numbers of each component are

$$N_{N_2} = \frac{m_{N_2}}{M_{N_2}} = \frac{0.15 \text{ lbm}}{28 \text{ lbm/lbmol}} = 0.005357 \text{ lbmol}$$

$$N_{He} = \frac{m_{He}}{M_{He}} = \frac{0.05 \text{ lbm}}{4 \text{ lbm/lbmol}} = 0.0125 \text{ lbmol}$$

$$N_{CH_4} = \frac{m_{CH_4}}{M_{CH_4}} = \frac{0.6 \text{ lbm}}{16 \text{ lbm/lbmol}} = 0.0375 \text{ lbmol}$$

$$N_{C_2H_6} = \frac{m_{C_2H_6}}{M_{C_2H_6}} = \frac{0.20 \text{ lbm}}{30 \text{ lbm/lbmol}} = 0.006667 \text{ lbmol}$$

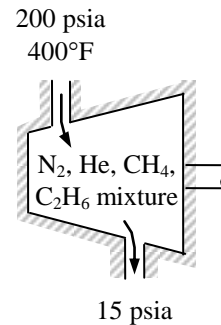

The mole number of the mixture is

$$N_m = N_{O_2} + N_{CO_2} + N_{He} = 0.005357 + 0.0125 + 0.0375 + 0.006667 = 0.06202 \text{ lbmol}$$

The apparent molecular weight of the mixture is

$$M_m = \frac{m_m}{N_m} = \frac{1 \text{ lbm}}{0.06202 \text{ lbmol}} = 16.12 \text{ lbm/lbmol}$$

The apparent gas constant of the mixture is

$$R = \frac{R_u}{M_m} = \frac{1.9858 \text{ lbm/lbmol} \cdot \text{R}}{16.12 \text{ lbm/lbmol}} = 0.1232 \text{ Btu/lbm} \cdot \text{R}$$

The constant-pressure specific heat of the mixture is determined from

$$c_p = mf_{N_2} c_{p,N_2} + mf_{He} c_{p,He} + mf_{CH_4} c_{p,CH_4} + mf_{C_2H_6} c_{p,C_2H_6}$$

$$= 0.15 \times 0.248 + 0.05 \times 1.25 + 0.60 \times 0.532 + 0.20 \times 0.427$$

$$= 0.5043 \text{ Btu/lbm} \cdot \text{R}$$

Then the constant-volume specific heat is

$$c_v = c_p - R = 0.5043 - 0.1232 = 0.3811 \text{ Btu/lbm} \cdot \text{R}$$

The specific heat ratio is

$$k = \frac{c_p}{c_v} = \frac{0.5043}{0.3811} = 1.323$$

The temperature at the end of the expansion for the isentropic process is

$$T_{2s} = T_1 \left(\frac{P_2}{P_1} \right)^{(k-1)/k} = (860 \text{ R}) \left(\frac{15 \text{ psia}}{200 \text{ psia}} \right)^{0.323/1.33} = 456.8 \text{ R}$$

Using the definition of turbine isentropic efficiency, the actual outlet temperature is

$$T_2 = T_1 - \eta_{\text{turb}} (T_1 - T_{2s}) = (860 \text{ R}) - (0.85)(860 - 456.8) = 517.3 \text{ R}$$

The entropy change of the gas mixture is

$$s_2 - s_1 = c_p \ln \frac{T_2}{T_1} - R \ln \frac{P_2}{P_1} = (0.5043) \ln \frac{517.3}{860} - (0.1232) \ln \frac{15}{200} = 0.06270 \text{ Btu/lbm} \cdot \text{R}$$

The actual work produced is

$$w_{\text{out}} = h_1 - h_2 = c_p (T_1 - T_2) = (0.5043 \text{ Btu/lbm} \cdot \text{R})(860 - 517.3) \text{ R} = 172.8 \text{ Btu/lbm}$$

The reversible work output is

$$w_{\text{rev,out}} = h_1 - h_2 - T_0 (s_1 - s_2) = 172.8 \text{ Btu/lbm} - (537 \text{ R})(-0.06270 \text{ Btu/lbm} \cdot \text{R}) = 206.5 \text{ Btu/lbm}$$

The second-law efficiency and the exergy destruction are then

$$\eta_{\text{II}} = \frac{w_{\text{out}}}{w_{\text{rev,out}}} = \frac{172.8}{206.5} = 0.837 = \mathbf{83.7\%}$$

$$x_{\text{dest}} = w_{\text{rev,out}} - w_{\text{out}} = 206.5 - 172.8 = \mathbf{33.7 \text{ Btu/lbm}}$$



13-98 A program is to be written to determine the mole fractions of the components of a mixture of three gases with known molar masses when the mass fractions are given, and to determine the mass fractions of the components when the mole fractions are given. Also, the program is to be run for a sample case.

Analysis The problem is solved using EES, and the solution is given below.

```

Procedure Fractions(Type$,A$,B$,C$,A,B,C:mf_A,mf_B,mf_C,y_A,y_B,y_C)
{If Type$ <> ('mass fraction' OR 'mole fraction') then
Call ERROR('Type$ must be set equal to "mass fraction" or "mole fraction".')
GOTO 10
endif}
Sum = A+B+C
If ABS(Sum - 1) > 0 then goto 20
MM_A = molarmass(A$)
MM_B = molarmass(B$)
MM_C = molarmass(C$)
If Type$ = 'mass fraction' then
mf_A = A
mf_B = B
mf_C = C
sumM_mix = mf_A/MM_A+ mf_B/MM_B+ mf_C/MM_C
y_A = mf_A/MM_A/sumM_mix
y_B = mf_B/MM_B/sumM_mix
y_C = mf_C/MM_C/sumM_mix
GOTO 10
endif
if Type$ = 'mole fraction' then
y_A = A
y_B = B
y_C = C
MM_mix = y_A*MM_A+ y_B*MM_B+ y_C*MM_C
mf_A = y_A*MM_A/MM_mix
mf_B = y_B*MM_B/MM_mix
mf_C = y_C*MM_C/MM_mix
GOTO 10
endif
Call ERROR('Type$ must be either mass fraction or mole fraction.')
GOTO 10
20:
Call ERROR('The sum of the mass or mole fractions must be 1')
10:
END

```

"Either the mole fraction y_i or the mass fraction mf_i may be given by setting the parameter $Type\$='mole\ fraction'$ when the mole fractions are given or $Type\$='mass\ fraction'$ is given"

```

{Input Data in the Diagram Window}
{Type$='mole fraction'
A$ = 'N2'
B$ = 'O2'
C$ = 'Argon'
A = 0.71 "When Type$='mole fraction' A, B, C are the mole fractions"
B = 0.28 "When Type$='mass fraction' A, B, C are the mass fractions"
C = 0.01}
Call Fractions(Type$,A$,B$,C$,A,B,C:mf_A,mf_B,mf_C,y_A,y_B,y_C)

```

SOLUTION

A=0.71	A\$='N2'	B=0.28	B\$='O2'
C=0.01	C\$='Argon'	mf_A=0.680	mf_B=0.306
mf_C=0.014	Type\$='mole fraction'		y_A=0.710
y_B=0.280	y_C=0.010		



13-99 A program is to be written to determine the apparent gas constant, constant volume specific heat, and internal energy of a mixture of 3 ideal gases when the mass fractions and other properties of the constituent gases are given. Also, the program is to be run for a sample case.

Analysis The problem is solved using EES, and the solution is given below.

```

T=300 [K]
A$ = 'N2'
B$ = 'O2'
C$ = 'CO2'
mf_A = 0.71
mf_B = 0.28
mf_C = 0.01
R_u = 8.314 [kJ/kmol-K]
MM_A = molarmass(A$)
MM_B = molarmass(B$)
MM_C = molarmass(C$)
SumM_mix = mf_A/MM_A+ mf_B/MM_B+ mf_C/MM_C
y_A = mf_A/MM_A/SumM_mix
y_B = mf_B/MM_B/SumM_mix
y_C = mf_C/MM_C/SumM_mix
MM_mix = y_A*MM_A+ y_B*MM_B+ y_C*MM_C

R_mix = R_u/MM_mix
C_P_mix=mf_A*specheat(A$,T=T)+mf_B*specheat(B$,T=T)+mf_C*specheat(C$,T=T)
C_V_mix=C_P_mix - R_mix
u_mix=C_V_mix*T
h_mix=C_P_mix*T

```

SOLUTION

```

A$='N2'
B$='O2'
C$='CO2'
C_P_mix=1.006 [kJ/kg-K]
C_V_mix=0.7206 [kJ/kg-K]
h_mix=301.8 [kJ/kg]
mf_A=0.71
mf_B=0.28
mf_C=0.01
MM_A=28.01 [kg/kmol]
MM_B=32 [kg/kmol]
MM_C=44.01 [kg/kmol]
MM_mix=29.14 [kg/kmol]
R_mix=0.2854 [kJ/kg-K]
R_u=8.314 [kJ/kmol-K]
SumM_mix=0.03432
T=300 [K]
u_mix=216.2 [kJ/kg]
y_A=0.7384
y_B=0.2549
y_C=0.00662

```

13-100 Using Amagat's law, it is to be shown that $Z_m = \sum_{i=1}^k y_i Z_i$ for a real-gas mixture.

Analysis Using the compressibility factor, the volume of a component of a real-gas mixture and of the volume of the gas mixture can be expressed as

$$v_i = \frac{Z_i N_i R_u T_m}{P_m} \quad \text{and} \quad v_m = \frac{Z_m N_m R_u T_m}{P_m}$$

Amagat's law can be expressed as

$$v_m = \sum v_i(T_m, P_m).$$

Substituting,

$$\frac{Z_m N_m R_u T_m}{P_m} = \sum \frac{Z_i N_i R_u T_m}{P_m}$$

Simplifying,

$$Z_m N_m = \sum Z_i N_i$$

Dividing by N_m ,

$$Z_m = \sum y_i Z_i$$

where Z_i is determined at the mixture temperature and pressure.

Fundamentals of Engineering (FE) Exam Problems

13-101 An ideal gas mixture whose apparent molar mass is 20 kg/kmol consists of nitrogen N₂ and three other gases. If the mole fraction of nitrogen is 0.55, its mass fraction is

- (a) 0.15 (b) 0.23 (c) 0.39 (d) 0.55 (e) 0.77

Answer (e) 0.77

Solution Solved by EES Software. Solutions can be verified by copying-and-pasting the following lines on a blank EES screen. (Similar problems and their solutions can be obtained easily by modifying numerical values).

```
M_mix=20 "kg/kmol"
M_N2=28 "kg/kmol"
y_N2=0.55
mf_N2=(M_N2/M_mix)*y_N2
```

"Some Wrong Solutions with Common Mistakes:"

```
W1_mf = y_N2 "Taking mass fraction to be equal to mole fraction"
W2_mf= y_N2*(M_mix/M_N2) "Using the molar mass ratio backwards"
W3_mf= 1-mf_N2 "Taking the complement of the mass fraction"
```

13-102 An ideal gas mixture consists of 2 kmol of N₂ and 6 kmol of CO₂. The mass fraction of CO₂ in the mixture is

- (a) 0.175 (b) 0.250 (c) 0.500 (d) 0.750 (e) 0.825

Answer (e) 0.825

Solution Solved by EES Software. Solutions can be verified by copying-and-pasting the following lines on a blank EES screen. (Similar problems and their solutions can be obtained easily by modifying numerical values).

```
N1=2 "kmol"
N2=6 "kmol"
N_mix=N1+N2
MM1=28 "kg/kmol"
MM2=44 "kg/kmol"
m_mix=N1*MM1+N2*MM2
mf2=N2*MM2/m_mix
```

"Some Wrong Solutions with Common Mistakes:"

```
W1_mf = N2/N_mix "Using mole fraction"
W2_mf = 1-mf2 "The wrong mass fraction"
```

13-103 An ideal gas mixture consists of 2 kmol of N_2 and 4 kmol of CO_2 . The apparent gas constant of the mixture is

- (a) 0.215 kJ/kg·K (b) 0.225 kJ/kg·K (c) 0.243 kJ/kg·K (d) 0.875 kJ/kg·K (e) 1.24 kJ/kg·K

Answer (a) 0.215 kJ/kg·K

Solution Solved by EES Software. Solutions can be verified by copying-and-pasting the following lines on a blank EES screen. (Similar problems and their solutions can be obtained easily by modifying numerical values).

```
Ru=8.314 "kJ/kmol.K"
N1=2 "kmol"
N2=4 "kmol"
MM1=28 "kg/kmol"
MM2=44 "kg/kmol"
R1=Ru/MM1
R2=Ru/MM2
N_mix=N1+N2
y1=N1/N_mix
y2=N2/N_mix
MM_mix=y1*MM1+y2*MM2
R_mix=Ru/MM_mix
```

"Some Wrong Solutions with Common Mistakes:"

```
W1_Rmix=(R1+R2)/2 "Taking the arithmetic average of gas constants"
W2_Rmix=y1*R1+y2*R2 "Using wrong relation for Rmixture"
```

13-104 A rigid tank is divided into two compartments by a partition. One compartment contains 3 kmol of N_2 at 400 kPa pressure and the other compartment contains 7 kmol of CO_2 at 200 kPa. Now the partition is removed, and the two gases form a homogeneous mixture at 250 kPa. The partial pressure of N_2 in the mixture is

- (a) 75 kPa (b) 90 kPa (c) 125 kPa (d) 175 kPa (e) 250 kPa

Answer (a) 75 kPa

Solution Solved by EES Software. Solutions can be verified by copying-and-pasting the following lines on a blank EES screen. (Similar problems and their solutions can be obtained easily by modifying numerical values).

```
P1 = 400 "kPa"
P2 = 200 "kPa"
P_mix=250 "kPa"
N1=3 "kmol"
N2=7 "kmol"
MM1=28 "kg/kmol"
MM2=44 "kg/kmol"
N_mix=N1+N2
y1=N1/N_mix
y2=N2/N_mix
P_N2=y1*P_mix
```

"Some Wrong Solutions with Common Mistakes:"

```
W1_P1= P_mix/2 "Assuming equal partial pressures"
W2_P1= mf1*P_mix; mf1=N1*MM1/(N1*MM1+N2*MM2) "Using mass fractions"
W3_P1 = P_mix*N1*P1/(N1*P1+N2*P2) "Using some kind of weighed averaging"
```

13-105 An 80-L rigid tank contains an ideal gas mixture of 5 g of N_2 and 5 g of CO_2 at a specified pressure and temperature. If N_2 were separated from the mixture and stored at mixture temperature and pressure, its volume would be

- (a) 32 L (b) 36 L (c) 40 L (d) 49 L (e) 80 L

Answer (d) 49 L

Solution Solved by EES Software. Solutions can be verified by copying-and-pasting the following lines on a blank EES screen. (Similar problems and their solutions can be obtained easily by modifying numerical values).

```
V_mix=80 "L"
m1=5 "g"
m2=5 "g"
MM1=28 "kg/kmol"
MM2=44 "kg/kmol"
N1=m1/MM1
N2=m2/MM2
N_mix=N1+N2
y1=N1/N_mix
V1=y1*V_mix "L"
```

"Some Wrong Solutions with Common Mistakes:"

```
W1_V1=V_mix*m1/(m1+m2) "Using mass fractions"
W2_V1= V_mix "Assuming the volume to be the mixture volume"
```

13-106 An ideal gas mixture consists of 3 kg of Ar and 6 kg of CO_2 gases. The mixture is now heated at constant volume from 250 K to 350 K. The amount of heat transfer is

- (a) 374 kJ (b) 436 kJ (c) 488 kJ (d) 525 kJ (e) 664 kJ

Answer (c) 488 kJ

Solution Solved by EES Software. Solutions can be verified by copying-and-pasting the following lines on a blank EES screen. (Similar problems and their solutions can be obtained easily by modifying numerical values).

```
T1=250 "K"
T2=350 "K"
Cv1=0.3122; Cp1=0.5203 "kJ/kg.K"
Cv2=0.657; Cp2=0.846 "kJ/kg.K"
m1=3 "kg"
m2=6 "kg"
MM1=39.95 "kg/kmol"
MM2=44 "kg/kmol"
"Applying Energy balance gives Q=DeltaU=DeltaU_Ar+DeltaU_CO2"
Q=(m1*Cv1+m2*Cv2)*(T2-T1)
```

"Some Wrong Solutions with Common Mistakes:"

```
W1_Q = (m1+m2)*(Cv1+Cv2)/2*(T2-T1) "Using arithmetic average of properties"
W2_Q = (m1*Cp1+m2*Cp2)*(T2-T1)"Using Cp instead of Cv"
W3_Q = (m1*Cv1+m2*Cv2)*T2 "Using T2 instead of T2-T1"
```

13-107 An ideal gas mixture consists of 60% helium and 40% argon gases by mass. The mixture is now expanded isentropically in a turbine from 400°C and 1.2 MPa to a pressure of 200 kPa. The mixture temperature at turbine exit is

- (a) 56°C (b) 195°C (c) 130°C (d) 112°C (e) 400°C

Answer (a) 56°C

Solution Solved by EES Software. Solutions can be verified by copying-and-pasting the following lines on a blank EES screen. (Similar problems and their solutions can be obtained easily by modifying numerical values).

T1=400+273"K"

P1=1200 "kPa"

P2=200 "kPa"

mf_He=0.6

mf_Ar=0.4

k1=1.667

k2=1.667

"The specific heat ratio k of the mixture is also 1.667 since k=1.667 for all componet gases"

k_mix=1.667

T2=T1*(P2/P1)^((k_mix-1)/k_mix)-273

"Some Wrong Solutions with Common Mistakes:"

W1_T2 = (T1-273)*(P2/P1)^((k_mix-1)/k_mix) "Using C for T1 instead of K"

W2_T2 = T1*(P2/P1)^((k_air-1)/k_air)-273; k_air=1.4 "Using k value for air"

W3_T2 = T1*P2/P1 "Assuming T to be proportional to P"

13-108 One compartment of an insulated rigid tank contains 2 kmol of CO₂ at 20°C and 150 kPa while the other compartment contains 5 kmol of H₂ gas at 35°C and 300 kPa. Now the partition between the two gases is removed, and the two gases form a homogeneous ideal gas mixture. The temperature of the mixture is

- (a) 25°C (b) 29°C (c) 22°C (d) 32°C (e) 34°C

Answer (b) 29°C

Solution Solved by EES Software. Solutions can be verified by copying-and-pasting the following lines on a blank EES screen. (Similar problems and their solutions can be obtained easily by modifying numerical values).

N_H2=5 "kmol"

T1_H2=35 "C"

P1_H2=300 "kPa"

N_CO2=2 "kmol"

T1_CO2=20 "C"

P1_CO2=150 "kPa"

Cv_H2=10.183; Cp_H2=14.307 "kJ/kg.K"

Cv_CO2=0.657; Cp_CO2=0.846 "kJ/kg.K"

MM_H2=2 "kg/kmol"

MM_CO2=44 "kg/kmol"

m_H2=N_H2*MM_H2

m_CO2=N_CO2*MM_CO2

"Applying Energy balance gives 0=DeltaU=DeltaU_H2+DeltaU_CO2"

0=m_H2*Cv_H2*(T2-T1_H2)+m_CO2*Cv_CO2*(T2-T1_CO2)

"Some Wrong Solutions with Common Mistakes:"

0=m_H2*Cp_H2*(W1_T2-T1_H2)+m_CO2*Cp_CO2*(W1_T2-T1_CO2) "Using Cp instead of Cv"

0=N_H2*Cv_H2*(W2_T2-T1_H2)+N_CO2*Cv_CO2*(W2_T2-T1_CO2) "Using N instead of mass"

W3_T2 = (T1_H2+T1_CO2)/2 "Assuming averate temperature"

13-109 A piston-cylinder device contains an ideal gas mixture of 3 kmol of He gas and 7 kmol of Ar gas at 50°C and 400 kPa. Now the gas expands at constant pressure until its volume doubles. The amount of heat transfer to the gas mixture is

- (a) 6.2 MJ (b) 42 MJ (c) 27 MJ (d) 10 MJ (e) 67 MJ

Answer (e) 67 MJ

Solution Solved by EES Software. Solutions can be verified by copying-and-pasting the following lines on a blank EES screen. (Similar problems and their solutions can be obtained easily by modifying numerical values).

```
N_He=3 "kmol"
N_Ar=7 "kmol"
T1=50+273 "C"
P1=400 "kPa"
P2=P1
"T2=2T1 since PV/T=const for ideal gases and it is given that P=constant"
T2=2*T1 "K"
MM_He=4 "kg/kmol"
MM_Ar=39.95 "kg/kmol"
m_He=N_He*MM_He
m_Ar=N_Ar*MM_Ar
Cp_Ar=0.5203; Cv_Ar = 3122 "kJ/kg.C"
Cp_He=5.1926; Cv_He = 3.1156 "kJ/kg.K"
"For a P=const process, Q=DeltaH since DeltaU+Wb is DeltaH"
Q=m_Ar*Cp_Ar*(T2-T1)+m_He*Cp_He*(T2-T1)
```

"Some Wrong Solutions with Common Mistakes:"

```
W1_Q =m_Ar*Cv_Ar*(T2-T1)+m_He*Cv_He*(T2-T1) "Using Cv instead of Cp"
W2_Q=N_Ar*Cp_Ar*(T2-T1)+N_He*Cp_He*(T2-T1) "Using N instead of mass"
W3_Q=m_Ar*Cp_Ar*(T2-T1)+m_He*Cp_He*(T2-T1); T2=2*(T1-273)+273 "Using C for T1"
W4_Q=(m_Ar+m_He)*0.5*(Cp_Ar+Cp_He)*(T2-T1) "Using arithmetic average of Cp"
```

13-110 An ideal gas mixture of helium and argon gases with identical mass fractions enters a turbine at 1500 K and 1 MPa at a rate of 0.12 kg/s, and expands isentropically to 100 kPa. The power output of the turbine is

- (a) 253 kW (b) 310 kW (c) 341 kW (d) 463 kW (e) 550 kW

Answer (b) 310 kW

Solution Solved by EES Software. Solutions can be verified by copying-and-pasting the following lines on a blank EES screen. (Similar problems and their solutions can be obtained easily by modifying numerical values).

```
m=0.12 "kg/s"
T1=1500 "K"
P1=1000 "kPa"
P2=100 "kPa"
mf_He=0.5
mf_Ar=0.5
k_He=1.667
k_Ar=1.667
Cp_Ar=0.5203
Cp_He=5.1926
Cp_mix=mf_He*Cp_He+mf_Ar*Cp_Ar
"The specific heat ratio k of the mixture is also 1.667 since k=1.667 for all componet gases"
k_mix=1.667
T2=T1*(P2/P1)^((k_mix-1)/k_mix)
-W_out=m*Cp_mix*(T2-T1)
```

"Some Wrong Solutions with Common Mistakes:"

```
W1_Wout= - m*Cp_mix*(T22-T1); T22 = (T1-273)*(P2/P1)^((k_mix-1)/k_mix)+273 "Using C for T1 instead of K"
W2_Wout= - m*Cp_mix*(T222-T1); T222 = T1*(P2/P1)^((k_air-1)/k_air)-273; k_air=1.4 "Using k value for air"
W3_Wout= - m*Cp_mix*(T2222-T1); T2222 = T1*P2/P1 "Assuming T to be proportional to P"
W4_Wout= - m*0.5*(Cp_Ar+Cp_He)*(T2-T1) "Using arithmetic average for Cp"
```

13-111 ... 13-113 Design and Essay Problem



Solutions Manual for
Thermodynamics: An Engineering Approach
8th Edition
Yunus A. Çengel, Michael A. Boles
McGraw-Hill, 2015

Chapter 14
GAS-VAPOR MIXTURES AND AIR
CONDITIONING

PROPRIETARY AND CONFIDENTIAL

This Manual is the proprietary property of McGraw-Hill Education and protected by copyright and other state and federal laws. By opening and using this Manual the user agrees to the following restrictions, and if the recipient does not agree to these restrictions, the Manual should be promptly returned unopened to McGraw-Hill Education: **This Manual is being provided only to authorized professors and instructors for use in preparing for the classes using the affiliated textbook. No other use or distribution of this Manual is permitted. This Manual may not be sold and may not be distributed to or used by any student or other third party. No part of this Manual may be reproduced, displayed or distributed in any form or by any means, electronic or otherwise, without the prior written permission of McGraw-Hill Education.**

Dry and Atmospheric Air: Specific and Relative Humidity

14-1C Dry air does not contain any water vapor, but atmospheric air does.

14-2C Specific humidity is the amount of water vapor present in a unit mass of dry air. Relative humidity is the ratio of the actual amount of vapor in the air at a given temperature to the maximum amount of vapor air can hold at that temperature.

14-3C Yes, the water vapor in the air can be treated as an ideal gas because of its very low partial pressure.

14-4C Yes.

14-5C Yes; by cooling the air at constant pressure.

14-6C Specific humidity will decrease but relative humidity will increase.

14-7C The specific humidity will remain constant, but the relative humidity will decrease as the temperature rises in a well-sealed room.

14-8C The specific humidity will remain constant, but the relative humidity will decrease as the temperature drops in a well-sealed room.

14-9C A tank that contains moist air at 3 atm is located in moist air that is at 1 atm. The driving force for moisture transfer is the vapor pressure difference, and thus it is possible for the water vapor to flow into the tank from surroundings if the vapor pressure in the surroundings is greater than the vapor pressure in the tank.

14-10C Insulations on *chilled water lines* are always wrapped with *vapor barrier jackets* to eliminate the possibility of vapor entering the insulation. This is because moisture that migrates through the insulation to the cold surface will condense and remain there indefinitely with no possibility of vaporizing and moving back to the outside.

14-11 A tank contains dry air and water vapor at specified conditions. The specific humidity, the relative humidity, and the volume of the tank are to be determined.

Assumptions The air and the water vapor are ideal gases.

Analysis (a) The specific humidity can be determined from its definition,

$$\omega = \frac{m_v}{m_a} = \frac{0.17 \text{ kg}}{15 \text{ kg}} = \mathbf{0.01133 \text{ kg H}_2\text{O/kg dry air}}$$

(b) The saturation pressure of water at 30°C is

$$P_g = P_{\text{sat @ } 30^\circ\text{C}} = 4.2469 \text{ kPa}$$

Then the relative humidity can be determined from

$$\phi = \frac{\omega P}{(0.622 + \omega)P_g} = \frac{(0.01133)(100 \text{ kPa})}{(0.622 + 0.01133)(4.2469 \text{ kPa})} = 0.4214 = \mathbf{42.1\%}$$

(c) The volume of the tank can be determined from the ideal gas relation for the dry air,

$$P_v = \phi P_g = (0.4214)(4.2469 \text{ kPa}) = 1.789 \text{ kPa}$$

$$P_a = P - P_v = 100 - 1.789 = 98.211 \text{ kPa}$$

$$V = \frac{m_a R_a T}{P_a} = \frac{(15 \text{ kg})(0.287 \text{ kJ/kg} \cdot \text{K})(303 \text{ K})}{98.211 \text{ kPa}} = \mathbf{13.3 \text{ m}^3}$$

15 kg dry air
0.17 kg H₂O vapor
30°C
100 kPa

14-12 A tank contains dry air and water vapor at specified conditions. The specific humidity, the relative humidity, and the volume of the tank are to be determined.

Assumptions The air and the water vapor are ideal gases.

Analysis (a) The specific humidity can be determined from its definition,

$$\omega = \frac{m_v}{m_a} = \frac{0.17 \text{ kg}}{15 \text{ kg}} = \mathbf{0.01133 \text{ kg H}_2\text{O/kg dry air}}$$

(b) The saturation pressure of water at 20°C is

$$P_g = P_{\text{sat @ } 20^\circ\text{C}} = 2.339 \text{ kPa}$$

Then the relative humidity can be determined from

$$\phi = \frac{\omega P}{(0.622 + \omega)P_g} = \frac{(0.01133)(100 \text{ kPa})}{(0.622 + 0.01133)(2.339 \text{ kPa})} = 0.7650 = \mathbf{76.5\%}$$

(c) The volume of the tank can be determined from the ideal gas relation for the dry air,

$$P_v = \phi P_g = (0.7650)(2.339 \text{ kPa}) = 1.789 \text{ kPa}$$

$$P_a = P - P_v = 100 - 1.789 = 98.211 \text{ kPa}$$

$$V = \frac{m_a R_a T}{P_a} = \frac{(15 \text{ kg})(0.287 \text{ kJ/kg} \cdot \text{K})(293 \text{ K})}{98.211 \text{ kPa}} = \mathbf{12.8 \text{ m}^3}$$

15 kg dry air
0.17 kg H₂O vapor
20°C
100 kPa

14-13 A room contains air at specified conditions and relative humidity. The partial pressure of air, the specific humidity, and the enthalpy per unit mass of dry air are to be determined.

Assumptions The air and the water vapor are ideal gases.

Analysis (a) The partial pressure of dry air can be determined from

$$P_v = \phi P_g = \phi P_{\text{sat @ } 20^\circ\text{C}} = (0.85)(2.3392 \text{ kPa}) = 1.988 \text{ kPa}$$

$$P_a = P - P_v = 98 - 1.988 = \mathbf{96.01 \text{ kPa}}$$

(b) The specific humidity of air is determined from

$$\omega = \frac{0.622 P_v}{P - P_v} = \frac{(0.622)(1.988 \text{ kPa})}{(98 - 1.988) \text{ kPa}} = \mathbf{0.0129 \text{ kg H}_2\text{O/kg dry air}}$$

(c) The enthalpy of air per unit mass of dry air is determined from

$$\begin{aligned} h &= h_a + \omega h_v \cong c_p T + \omega h_g \\ &= (1.005 \text{ kJ/kg} \cdot ^\circ\text{C})(20^\circ\text{C}) + (0.0129)(2537.4 \text{ kJ/kg}) \\ &= \mathbf{52.78 \text{ kJ/kg dry air}} \end{aligned}$$

AIR
20°C
98 kPa
85% RH

14-14 A room contains air at specified conditions and relative humidity. The partial pressure of air, the specific humidity, and the enthalpy per unit mass of dry air are to be determined.

Assumptions The air and the water vapor are ideal gases.

Analysis (a) The partial pressure of dry air can be determined from

$$P_v = \phi P_g = \phi P_{\text{sat @ } 20^\circ\text{C}} = (0.85)(2.3392 \text{ kPa}) = 1.988 \text{ kPa}$$

$$P_a = P - P_v = 85 - 1.988 = \mathbf{83.01 \text{ kPa}}$$

(b) The specific humidity of air is determined from

$$\omega = \frac{0.622 P_v}{P - P_v} = \frac{(0.622)(1.988 \text{ kPa})}{(85 - 1.988) \text{ kPa}} = \mathbf{0.0149 \text{ kg H}_2\text{O/kg dry air}}$$

(c) The enthalpy of air per unit mass of dry air is determined from

$$\begin{aligned} h &= h_a + \omega h_v \cong c_p T + \omega h_g \\ &= (1.005 \text{ kJ/kg} \cdot ^\circ\text{C})(20^\circ\text{C}) + (0.0149)(2537.4 \text{ kJ/kg}) \\ &= \mathbf{57.90 \text{ kJ/kg dry air}} \end{aligned}$$

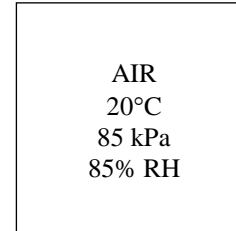

14-15E A room contains air at specified conditions and relative humidity. The partial pressure of air, the specific humidity, and the enthalpy per unit mass of dry air are to be determined.

Assumptions The air and the water vapor are ideal gases.

Analysis (a) The partial pressure of dry air can be determined from

$$P_v = \phi P_g = \phi P_{\text{sat @ } 85^\circ\text{F}} = (0.60)(0.5966 \text{ psia}) = 0.358 \text{ psia}$$

$$P_a = P - P_v = 13.5 - 0.358 = \mathbf{13.14 \text{ psia}}$$

(b) The specific humidity of air is determined from

$$\omega = \frac{0.622 P_v}{P - P_v} = \frac{(0.622)(0.358 \text{ psia})}{(13.5 - 0.358) \text{ psia}} = \mathbf{0.0169 \text{ lbm H}_2\text{O/lbm dry air}}$$

(c) The enthalpy of air per unit mass of dry air is determined from

$$\begin{aligned} h &= h_a + \omega h_v \cong c_p T + \omega h_g \\ &= (0.24 \text{ Btu/lbm} \cdot ^\circ\text{F})(85^\circ\text{F}) + (0.0169)(1098.3 \text{ Btu/lbm}) \\ &= \mathbf{39.01 \text{ Btu/lbm dry air}} \end{aligned}$$

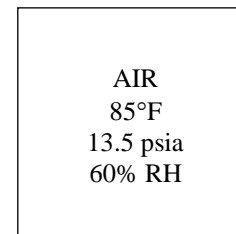

14-16 A tank contains saturated air at a specified temperature and pressure. The mass of dry air, the specific humidity, and the enthalpy of the air are to be determined.

Assumptions The air and the water vapor are ideal gases.

Analysis (a) The mass of dry air can be determined from the ideal gas relation for the dry air,

$$m_a = \frac{P_a \mathcal{V}}{R_a T} = \frac{[(105 - 4.2469) \text{ kPa}](8 \text{ m}^3)}{(0.287 \text{ kJ/kg} \cdot \text{K})(30 + 273.15 \text{ K})} = \mathbf{9.264 \text{ kg}}$$

(b) The relative humidity of air is 100 percent since the air is saturated. The vapor pressure is equal to the saturation pressure of water at 30°C

$$P_v = P_g = P_{\text{sat}@30^\circ\text{C}} = 4.2469 \text{ kPa}$$

The specific humidity can be determined from

$$\omega = \frac{0.622 P_v}{P - P_v} = \frac{(0.622)(4.2469 \text{ kPa})}{(105 - 4.2469) \text{ kPa}} = \mathbf{0.0262 \text{ kg H}_2\text{O/kg dry air}}$$

(c) The enthalpy of air per unit mass of dry air is determined from

$$\begin{aligned} h &= h_a + \omega h_v \cong c_p T + \omega h_g @ 30^\circ\text{C} \\ &= (1.005 \text{ kJ/kg} \cdot ^\circ\text{C})(30^\circ\text{C}) + (0.0262)(2555.6 \text{ kJ/kg}) \\ &= \mathbf{97.1 \text{ kJ/kg dry air}} \end{aligned}$$

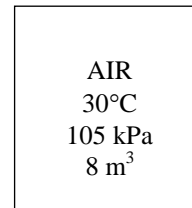

14-17 The masses of dry air and the water vapor contained in a room at specified conditions and relative humidity are to be determined.

Assumptions The air and the water vapor are ideal gases.

Analysis The partial pressure of water vapor and dry air are determined to be

$$\begin{aligned} P_v &= \phi P_g = \phi P_{\text{sat}@26^\circ\text{C}} = (0.50)(3.364 \text{ kPa}) = 1.682 \text{ kPa} \\ P_a &= P - P_v = 93 - 1.682 = 91.32 \text{ kPa} \end{aligned}$$

The masses are determined to be

$$\begin{aligned} m_a &= \frac{P_a \mathcal{V}}{R_a T} = \frac{(91.32 \text{ kPa})(90 \text{ m}^3)}{(0.287 \text{ kPa} \cdot \text{m}^3/\text{kg} \cdot \text{K})(299 \text{ K})} = \mathbf{95.8 \text{ kg}} \\ m_v &= \frac{P_v \mathcal{V}}{R_v T} = \frac{(1.682 \text{ kPa})(90 \text{ m}^3)}{(0.4615 \text{ kPa} \cdot \text{m}^3/\text{kg} \cdot \text{K})(299 \text{ K})} = \mathbf{1.10 \text{ kg}} \end{aligned}$$

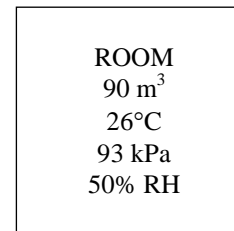

14-18 Humid air is compressed in an isentropic compressor. The relative humidity of the air at the compressor outlet is to be determined.

Assumptions The air and the water vapor are ideal gases.

Properties The specific heat ratio of air at room temperature is $k = 1.4$ (Table A-2a). The saturation properties of water are to be obtained from water tables.

Analysis At the inlet,

$$P_{v,1} = \phi_1 P_{g,1} = \phi_1 P_{\text{sat}@20^\circ\text{C}} = (0.90)(2.3392 \text{ kPa}) = 2.105 \text{ kPa}$$

$$\omega_2 = \omega_1 = \frac{0.622 P_{v,1}}{P - P_{v,1}} = \frac{(0.622)(2.105 \text{ kPa})}{(100 - 2.105) \text{ kPa}} = 0.0134 \text{ kg H}_2\text{O/kg dry air}$$

Since the mole fraction of the water vapor in this mixture is very small,

$$T_2 = T_1 \left(\frac{P_2}{P_1} \right)^{(k-1)/k} = (293 \text{ K}) \left(\frac{800 \text{ kPa}}{100 \text{ kPa}} \right)^{0.4/1.4} = 531 \text{ K}$$

The saturation pressure at this temperature is

$$P_{g,2} = P_{\text{sat}@258^\circ\text{C}} = 4542 \text{ kPa} \quad (\text{from EES})$$

The vapor pressure at the exit is

$$P_{v,2} = \frac{\omega_2 P_2}{\omega_2 + 0.622} = \frac{(0.0134)(800)}{0.0134 + 0.622} = 16.87 \text{ kPa}$$

The relative humidity at the exit is then

$$\phi_2 = \frac{P_{v,2}}{P_{g,2}} = \frac{16.87}{4542} = \mathbf{0.0037 = 0.37\%}$$

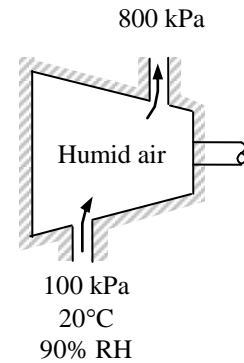

Dew-Point, Adiabatic Saturation, and Wet-bulb Temperatures

14-19C Dew-point temperature is the temperature at which condensation begins when air is cooled at constant pressure.

14-20C Andy's. The temperature of his glasses may be below the dew-point temperature of the room, causing condensation on the surface of the glasses.

14-21C The outer surface temperature of the glass may drop below the dew-point temperature of the surrounding air, causing the moisture in the vicinity of the glass to condense. After a while, the condensate may start dripping down because of gravity.

14-22C When the temperature falls below the dew-point temperature, dew forms on the outer surfaces of the car. If the temperature is below 0°C, the dew will freeze. At very low temperatures, the moisture in the air will freeze directly on the car windows.

14-23C When the air is saturated (100% relative humidity).

14-24C These two are approximately equal at atmospheric temperatures and pressure.

14-25 A person wearing glasses enters a warm room at a specified temperature and relative humidity from the cold outdoors. It is to be determined whether the glasses will get fogged.

Assumptions The air and the water vapor are ideal gases.

Analysis The vapor pressure P_v of the air in the house is uniform throughout, and its value can be determined from

$$P_v = \phi P_g @ 25^\circ\text{C} = (0.55)(3.1698 \text{ kPa}) = 1.743 \text{ kPa}$$

The dew-point temperature of the air in the house is

$$T_{\text{dp}} = T_{\text{sat} @ P_v} = T_{\text{sat} @ 1.743 \text{ kPa}} = \mathbf{15.3^\circ\text{C}} \quad (\text{Table A-5 or EES})$$

That is, the moisture in the house air will start condensing when the air temperature drops below 15.3°C. Since the glasses are at a lower temperature than the dew-point temperature, some moisture will condense on the glasses, and thus they **will get fogged**.

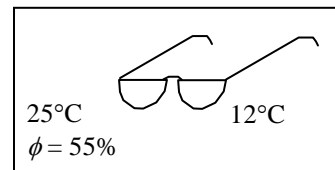

14-26 A person wearing glasses enters a warm room at a specified temperature and relative humidity from the cold outdoors. It is to be determined whether the glasses will get fogged.

Assumptions The air and the water vapor are ideal gases.

Analysis The vapor pressure P_v of the air in the house is uniform throughout, and its value can be determined from

$$P_v = \phi P_g @ 25^\circ\text{C} = (0.30)(3.1698 \text{ kPa}) = 0.9509 \text{ kPa}$$

The dew-point temperature of the air in the house is

$$T_{\text{dp}} = T_{\text{sat}} @ P_v = T_{\text{sat}} @ 0.9509 \text{ kPa} = \mathbf{6.2^\circ\text{C}}$$
 (Table A-5 or EES)

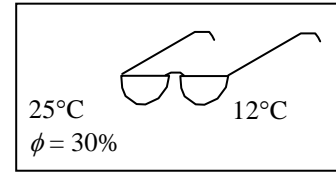

That is, the moisture in the house air will start condensing when the air temperature drops below 6.2°C . Since the glasses are at a higher temperature than the dew-point temperature, moisture will not condense on the glasses, and thus they **will not get fogged**.

14-27E A woman drinks a cool canned soda in a room at a specified temperature and relative humidity. It is to be determined whether the can will sweat.

Assumptions The air and the water vapor are ideal gases.

Analysis The vapor pressure P_v of the air in the house is uniform throughout, and its value can be determined from

$$P_v = \phi P_g @ 70^\circ\text{F} = (0.38)(0.3633 \text{ psia}) = 0.1381 \text{ psia}$$

The dew-point temperature of the air in the house is

$$T_{\text{dp}} = T_{\text{sat}} @ P_v = T_{\text{sat}} @ 0.1381 \text{ psia} = \mathbf{43.3^\circ\text{F}}$$
 (from EES)

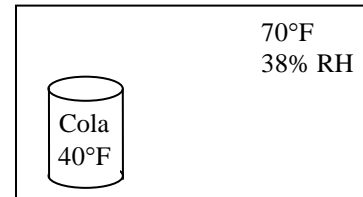

That is, the moisture in the house air will start condensing when the air temperature drops below 43.3°C . Since the canned drink is at a lower temperature than the dew-point temperature, some moisture will condense on the can, and thus it **will sweat**.

14-28 The dry- and wet-bulb temperatures of atmospheric air at a specified pressure are given. The specific humidity, the relative humidity, and the enthalpy of air are to be determined.

Assumptions The air and the water vapor are ideal gases.

Analysis (a) We obtain the properties of water vapor from EES. The specific humidity ω_1 is determined from

$$\omega_1 = \frac{c_p(T_2 - T_1) + \omega_2 h_{fg2}}{h_{g1} - h_{f2}}$$

where T_2 is the wet-bulb temperature, and ω_2 is determined from

$$\omega_2 = \frac{0.622 P_{g2}}{P_2 - P_{g2}} = \frac{(0.622)(1.938 \text{ kPa})}{(95 - 1.938) \text{ kPa}} = 0.01295 \text{ kg H}_2\text{O/kg dry air}$$

<p>95 kPa 25°C $T_{\text{wb}} = 17^\circ\text{C}$</p>
--

Thus,

$$\omega_1 = \frac{(1.005 \text{ kJ/kg} \cdot ^\circ\text{C})(17 - 25)^\circ\text{C} + (0.01295)(2460.6 \text{ kJ/kg})}{(2546.5 - 71.36) \text{ kJ/kg}} = \mathbf{0.00963 \text{ kg H}_2\text{O/kg dry air}}$$

(b) The relative humidity ϕ_1 is determined from

$$\phi_1 = \frac{\omega_1 P_1}{(0.622 + \omega_1) P_{g1}} = \frac{(0.00963)(95 \text{ kPa})}{(0.622 + 0.00963)(3.1698 \text{ kPa})} = 0.457 \text{ or } \mathbf{45.7\%}$$

(c) The enthalpy of air per unit mass of dry air is determined from

$$\begin{aligned} h_1 &= h_{a1} + \omega_1 h_{v1} \\ &\cong c_p T_1 + \omega_1 h_{g1} \\ &= (1.005 \text{ kJ/kg} \cdot ^\circ\text{C})(25^\circ\text{C}) + (0.00963)(2546.5 \text{ kJ/kg}) \\ &= \mathbf{49.65 \text{ kJ/kg dry air}} \end{aligned}$$

14-29 The dry- and wet-bulb temperatures of air in room at a specified pressure are given. The specific humidity, the relative humidity, and the dew-point temperature are to be determined.

Assumptions The air and the water vapor are ideal gases.

Analysis (a) We obtain the properties of water vapor from EES. The specific humidity ω_1 is determined from

$$\omega_1 = \frac{c_p(T_2 - T_1) + \omega_2 h_{fg2}}{h_{g1} - h_{f2}}$$

where T_2 is the wet-bulb temperature, and ω_2 is determined from

$$\omega_2 = \frac{0.622 P_{g2}}{P_2 - P_{g2}} = \frac{(0.622)(2.488 \text{ kPa})}{(100 - 2.488) \text{ kPa}} = 0.01587 \text{ kg H}_2\text{O/kg dry air}$$

<p>100 kPa 26°C $T_{\text{wb}} = 21^\circ\text{C}$</p>

Thus,

$$\omega_1 = \frac{(1.005 \text{ kJ/kg} \cdot ^\circ\text{C})(21 - 26)^\circ\text{C} + (0.01587)(2451.2 \text{ kJ/kg})}{(2548.3 - 88.10) \text{ kJ/kg}} = \mathbf{0.01377 \text{ kg H}_2\text{O/kg dry air}}$$

(b) The relative humidity ϕ_1 is determined from

$$\phi_1 = \frac{\omega_1 P_1}{(0.622 + \omega_1) P_{g1}} = \frac{(0.01377)(100 \text{ kPa})}{(0.622 + 0.01377)(3.3638 \text{ kPa})} = 0.644 \text{ or } \mathbf{64.4\%}$$

(c) The vapor pressure at the inlet conditions is

$$P_{v1} = \phi_1 P_{g1} = \phi_1 P_{\text{sat}@26^\circ\text{C}} = (0.644)(3.3638 \text{ kPa}) = 2.166 \text{ kPa}$$

Thus the dew-point temperature of the air is

$$T_{\text{dp}} = T_{\text{sat}@P_v} = T_{\text{sat}@2.166 \text{ kPa}} = \mathbf{18.8^\circ\text{C}}$$



14-30 Problem 14-29 is reconsidered. The required properties are to be determined using EES at 100 and 300 kPa pressures.

Analysis The problem is solved using EES, and the solution is given below.

```
Tdb=26 [C]
Twb=21 [C]
P1=100 [kPa]
P2=300 [kPa]

h1=enthalpy(AirH2O,T=Tdb,P=P1,B=Twb)
v1=volume(AirH2O,T=Tdb,P=P1,B=Twb)
Tdp1=dewpoint(AirH2O,T=Tdb,P=P1,B=Twb)
w1=humrat(AirH2O,T=Tdb,P=P1,B=Twb)
Rh1=relhum(AirH2O,T=Tdb,P=P1,B=Twb)

h2=enthalpy(AirH2O,T=Tdb,P=P2,B=Twb)
v2=volume(AirH2O,T=Tdb,P=P2,B=Twb)
Tdp2=dewpoint(AirH2O,T=Tdb,P=P2,B=Twb)
w2=humrat(AirH2O,T=Tdb,P=P2,B=Twb)
Rh2=relhum(AirH2O,T=Tdb,P=P2,B=Twb)
```

SOLUTION

```
h1=61.25 [kJ/kg]
h2=34.16 [kJ/kg]
P1=100 [kPa]
P2=300 [kPa]
Rh1=0.6437
Rh2=0.4475
Tdb=26 [C]
Tdp1=18.76
Tdp2=13.07
Twb=21 [C]
v1=0.8777 [m^3/kg]
v2=0.2877 [m^3/kg]
w1=0.01376 [kg/kg]
w2=0.003136 [kg/kg]
```

Alternative Solution

The following EES routine can also be used to solve this problem. The above EES routine uses built-in psychrometric functions whereas the one below uses analytical expressions together with steam properties.

"Given"

```
T_db=26 [C]
T_wb=21 [C]
P=100 [kPa]
```

"Properties"

```
Fluid$='steam_iapws'
P_g1=pressure(Fluid$, T=T_db, x=1)
P_g2=pressure(Fluid$, T=T_wb, x=1)
h_g1=enthalpy(Fluid$, T=T_db, x=1)
h_g2=enthalpy(Fluid$, T=T_wb, x=1)
h_f2=enthalpy(Fluid$, T=T_wb, x=0)
h_fg2=h_g2-h_f2
c_p=1.005 [kJ/kg-C] "for air"
```

"Analysis"

"(a)"

$$w_2 = (0.622 * P_{g2}) / (P - P_{g2}) \text{ "kg H}_2\text{O/kg dry air"}$$

$$w_1 = (c_p * (T_{wb} - T_{db}) + w_2 * h_{fg2}) / (h_{g1} - h_{f2})$$

"(b)"

$$\phi_{1} = (w_1 * P) / ((0.622 + w_1) * P_{g1})$$

"(c)"

$$P_{v1} = \phi_1 * P_{g1}$$

$$T_{dp} = \text{temperature}(\text{Fluid\$}, P = P_{v1}, x = 1)$$

SOLUTION

$$c_p = 1.005 \text{ [kJ/kg-C]}$$

$$\text{Fluid\$} = \text{'steam_iapws'}$$

$$h_{f2} = 88.1 \text{ [kJ/kg]}$$

$$h_{fg2} = 2451.2 \text{ [kJ/kg]}$$

$$h_{g1} = 2548.3 \text{ [kJ/kg]}$$

$$h_{g2} = 2539.3 \text{ [kJ/kg]}$$

$$P = 100 \text{ [kPa]}$$

$$\phi_1 = 0.6439$$

$$P_{g1} = 3.3638 \text{ [kPa]}$$

$$P_{g2} = 2.488 \text{ [kPa]}$$

$$P_{v1} = 2.166 \text{ [kPa]}$$

$$T_{db} = 26 \text{ [C]}$$

$$T_{dp} = 18.8 \text{ [C]}$$

$$T_{wb} = 21 \text{ [C]}$$

$$w_1 = 0.01377$$

$$w_2 = 0.01587$$

14-31E The dry- and wet-bulb temperatures of air in room at a specified pressure are given. The specific humidity, the relative humidity, and the dew-point temperature are to be determined.

Assumptions The air and the water vapor are ideal gases.

Analysis (a) The specific humidity ω_1 is determined from

$$\omega_1 = \frac{c_p(T_2 - T_1) + \omega_2 h_{fg2}}{h_{g1} - h_{f2}}$$

where T_2 is the wet-bulb temperature, and ω_2 is determined from

$$\omega_2 = \frac{0.622 P_{g2}}{P_2 - P_{g2}} = \frac{(0.622)(0.30578 \text{ psia})}{(14.3 - 0.30578) \text{ psia}} = 0.01359 \text{ lbm H}_2\text{O/lbm dry air}$$

Thus,

$$\omega_1 = \frac{(0.24 \text{ Btu/lbm} \cdot ^\circ\text{F})(65 - 75)^\circ\text{F} + (0.01359)(1056.5 \text{ Btu/lbm})}{(1093.9 - 33.08) \text{ Btu/lbm}} = \mathbf{0.01127 \text{ lbm H}_2\text{O/lbm dry air}}$$

(b) The relative humidity ϕ_1 is determined from

$$\phi_1 = \frac{\omega_1 P_1}{(0.622 + \omega_1) P_{g1}} = \frac{(0.01127)(14.3 \text{ psia})}{(0.622 + 0.01127)(0.4302 \text{ psia})} = 0.5918 \text{ or } \mathbf{59.2\%}$$

(c) The vapor pressure at the inlet conditions is

$$P_{v1} = \phi_1 P_{g1} = \phi_1 P_{\text{sat}@75^\circ\text{F}} = (0.5918)(0.4302 \text{ psia}) = 0.2546 \text{ psia}$$

Thus the dew-point temperature of the air is

$$T_{\text{dp}} = T_{\text{sat}@P_v} = T_{\text{sat}@0.2546 \text{ psia}} = \mathbf{59.8^\circ\text{F}} \quad (\text{from EES})$$

$$\begin{aligned} &14.3 \text{ psia} \\ &75^\circ\text{F} \\ &T_{\text{wb}} = 65^\circ\text{F} \end{aligned}$$

14-32 Atmospheric air flows steadily into an adiabatic saturation device and leaves as a saturated vapor. The relative humidity and specific humidity of air are to be determined.

Assumptions 1 This is a steady-flow process and thus the mass flow rate of dry air remains constant during the entire process ($\dot{m}_{a1} = \dot{m}_{a2} = \dot{m}_a$). **2** Dry air and water vapor are ideal gases. **3** The kinetic and potential energy changes are negligible.

Analysis The exit state of the air is completely specified, and the total pressure is 98 kPa. The properties of the moist air at the exit state may be determined from EES to be

$$h_2 = 78.11 \text{ kJ/kg dry air}$$

$$\omega_2 = 0.02079 \text{ kg H}_2\text{O/kg dry air}$$

The enthalpy of makeup water is

$$h_{w2} = h_{f@25^\circ\text{C}} = 104.83 \text{ kJ/kg} \quad (\text{Table A-4})$$

An energy balance on the control volume gives

$$h_1 + (\omega_2 - \omega_1)h_w = h_2$$

$$h_1 + (0.02079 - \omega_1)(104.83 \text{ kJ/kg}) = 78.11 \text{ kJ/kg}$$

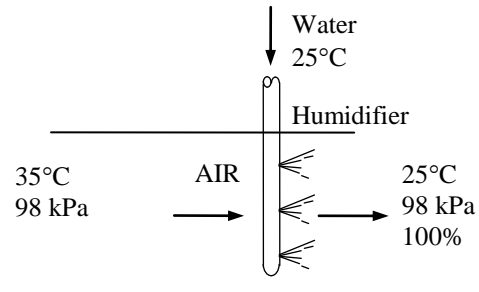

Pressure and temperature are known for inlet air. Other properties may be determined from this equation using EES. A hand solution would require a trial-error approach. The results are

$$h_1 = 77.66 \text{ kJ/kg dry air}$$

$$\omega_1 = \mathbf{0.01654 \text{ kg H}_2\text{O/kg dry air}}$$

$$\phi_1 = \mathbf{0.4511}$$

Psychrometric Chart

14-33C They are very nearly parallel to each other.

14-34C The saturation states (located on the saturation curve).

14-35C By drawing a horizontal line until it intersects with the saturation curve. The corresponding temperature is the dew-point temperature.

14-36C No, they cannot. The enthalpy of moist air depends on ω , which depends on the total pressure.

14-37E The pressure, temperature, and relative humidity of air in a room are specified. Using the psychrometric chart, the specific humidity, the enthalpy, the wet-bulb temperature, the dew-point temperature, and the specific volume of the air are to be determined.

Analysis From the psychrometric chart (Fig. A-31) we read

(a) $\omega = 0.0165 \text{ lbm H}_2\text{O} / \text{lbm dry air}$

(b) $h = 37.8 \text{ Btu} / \text{lbm dry air}$

(c) $T_{\text{wb}} = 74.3^\circ\text{F}$

(d) $T_{\text{dp}} = 71.3^\circ\text{F}$

(e) $\nu = 14.0 \text{ ft}^3 / \text{lbm dry air}$



14-38E Problem 14-37E is reconsidered. The required properties are to be determined using EES. Also, the properties are to be obtained at an altitude of 5000 ft.

Analysis The problem is solved using EES, and the solution is given below.

```
Tdb=82 [F]
Rh=0.70
P1=14.696 [psia]
Z = 5000 [ft]
Zeqv=Z*convert(ft,m)
P2=101.325*(1-0.02256*Zeqv/1000)^5.256*convert(kPa,psia)
"Relation giving P as a function of altitude"
```

```
h1=enthalpy(AirH2O,T=Tdb,P=P1,R=Rh)
v1=volume(AirH2O,T=Tdb,P=P1,R=Rh)
Tdp1=dewpoint(AirH2O,T=Tdb,P=P1,R=Rh)
w1=humrat(AirH2O,T=Tdb,P=P1,R=Rh)
Twb1=wetbulb(AirH2O,T=Tdb,P=P1,R=Rh)
```

```
h2=enthalpy(AirH2O,T=Tdb,P=P2,R=Rh)
v2=volume(AirH2O,T=Tdb,P=P2,R=Rh)
Tdp2=dewpoint(AirH2O,T=Tdb,P=P2,R=Rh)
w2=humrat(AirH2O,T=Tdb,P=P2,R=Rh)
Twb2=wetbulb(AirH2O,T=Tdb,P=P2,R=Rh)
```

SOLUTION

$h_1 = 37.78 \text{ [Btu/lbm]}$	$h_2 = 41.54 \text{ [Btu/lbm]}$
$P_1 = 14.7 \text{ [psia]}$	$P_2 = 12.23 \text{ [psia]}$
$R_h = 0.7$	$T_{\text{db}} = 82 \text{ [F]}$
$T_{\text{dp}1} = 71.25 \text{ [F]}$	$T_{\text{dp}2} = 71.25 \text{ [F]}$
$T_{\text{wb}1} = 74.27 \text{ [F]}$	$T_{\text{wb}2} = 73.89 \text{ [F]}$
$\nu_1 = 14.02 \text{ [ft}^3\text{/lbm]}$	$\nu_2 = 16.94 \text{ [ft}^3\text{/lbm]}$
$w_1 = 0.01647 \text{ [lbm/lbm]}$	$w_2 = 0.0199 \text{ [lbm/lbm]}$
$Z = 5000 \text{ [ft]}$	$Z_{\text{eqv}} = 1524 \text{ [m]}$

14-39 The pressure and the dry- and wet-bulb temperatures of air in a room are specified. Using the psychrometric chart, the specific humidity, the enthalpy, the relative humidity, the dew-point temperature, and the specific volume of the air are to be determined.

Analysis From the psychrometric chart (Fig. A-31) we read

(a) $\omega = 0.0092 \text{ kg H}_2\text{O} / \text{kg dry air}$

(b) $h = 47.6 \text{ kJ} / \text{kg dry air}$

(c) $\phi = 49.6\%$

(d) $T_{\text{dp}} = 12.8^\circ\text{C}$

(e) $\nu = 0.855 \text{ m}^3 / \text{kg dry air}$



14-40 Problem 14-39 is reconsidered. The required properties are to be determined using EES. Also, the properties are to be obtained at an altitude of 3000 m.

Analysis The problem is solved using EES, and the solution is given below.

```
Tdb=24 [C]
Twb=17 [C]
P1=101.325 [kPa]
Z = 3000 [m]
P2=101.325*(1-0.02256*Z*convert(m,km))^5.256 "Relation giving P as function of altitude"
```

```
h1=enthalpy(AirH2O,T=Tdb,P=P1,B=Twb)
v1=volume(AirH2O,T=Tdb,P=P1,B=Twb)
Tdp1=dewpoint(AirH2O,T=Tdb,P=P1,B=Twb)
w1=humrat(AirH2O,T=Tdb,P=P1,B=Twb)
Rh1=relhum(AirH2O,T=Tdb,P=P1,B=Twb)
```

```
h2=enthalpy(AirH2O,T=Tdb,P=P2,B=Twb)
v2=volume(AirH2O,T=Tdb,P=P2,B=Twb)
Tdp2=dewpoint(AirH2O,T=Tdb,P=P2,B=Twb)
w2=humrat(AirH2O,T=Tdb,P=P2,B=Twb)
Rh2=relhum(AirH2O,T=Tdb,P=P2,B=Twb)
```

SOLUTION

h1=47.61 [kJ/kg]	h2=61.68 [kJ/kg]
P1=101.3 [kPa]	P2=70.11 [kPa]
Rh1=0.4956	Rh2=0.5438
Tdb=24 [C]	Tdp1=12.81 [C]
Tdp2=14.24 [C]	Twb=17 [C]
v1=0.8542 [m ³ /kg]	v2=1.245 [m ³ /kg]
w1=0.009219 [kg/kg]	w2=0.01475 [kg/kg]
Z=3000 [m]	

Discussion The atmospheric pressure for a given elevation can also be obtained from Table A-16 of the book.

14-41 The pressure, temperature, and wet-bulb temperature of air are specified. Using the psychrometric chart, the relative humidity, specific humidity, the enthalpy, the dew-point temperature, and the water vapor pressure are to be determined.

Analysis From the psychrometric chart in Fig. A-31 or using EES psychrometric functions we obtain

$$(a) \phi = 0.480 = 48.0\%$$

$$(b) \omega = 0.0113 \text{ kg H}_2\text{O} / \text{kg dry air}$$

$$(c) h = 57.1 \text{ kJ/kg dry air}$$

$$(d) T_{\text{dp}} = 16.0^\circ\text{C}$$

$$(e) P_v = \phi P_g = \phi P_{\text{sat}} @ 28^\circ\text{C} = (0.480)(3.783 \text{ kPa}) = 1.82 \text{ kPa}$$

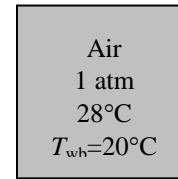

14-42 The pressure, temperature, and wet-bulb temperature of air are specified. The adiabatic saturation temperature is to be determined.

Analysis For an adiabatic saturation process, we obtained Eq. 14-14 in the text,

$$\omega_1 = \frac{c_p(T_2 - T_1) + \omega_2 h_{fg2}}{h_{g1} - h_{f2}}$$

This requires a trial-error solution for the adiabatic saturation temperature, T_2 . The inlet state properties are

$$\omega_1 = 0.0114 \text{ kg H}_2\text{O} / \text{kg dry air}$$

$$h_{g1} = h_g @ 28^\circ\text{C} = 2551.9 \text{ kJ/kg}$$

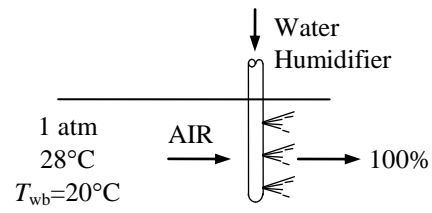

As a first estimate, let us take $T_2 = 20^\circ\text{C}$ (the inlet wet-bulb temperature). Also, at the exit, the relative humidity is 100% ($\phi_2 = 1$) and the pressure is 1 atm. Other properties at the exit state are

$$\omega_2 = 0.0147 \text{ kg H}_2\text{O} / \text{kg dry air}$$

$$h_{f2} = h_f @ 20^\circ\text{C} = 83.915 \text{ kJ/kg} \quad (\text{Table A - 4})$$

$$h_{fg2} = h_{fg} @ 20^\circ\text{C} = 2453.5 \text{ kJ/kg} \quad (\text{Table A - 4})$$

Substituting,

$$\omega_1 = \frac{c_p(T_2 - T_1) + \omega_2 h_{fg2}}{h_{g1} - h_{f2}} = \frac{(1.005)(20 - 28) + (0.0147)(2453.5)}{2551.9 - 83.915} = 0.0114 \text{ kg H}_2\text{O} / \text{kg dry air}$$

which is equal to the inlet specific humidity. Therefore, the adiabatic saturation temperature is

$$T_2 = \mathbf{20^\circ\text{C}}$$

Discussion This result is not surprising since the wet-bulb and adiabatic saturation temperatures are approximately equal to each other for air-water mixtures at atmospheric pressure.

14-43E The pressure, temperature, and wet-bulb temperature of air are specified. Using the psychrometric chart, the relative humidity, specific humidity, the enthalpy, the dew-point temperature, and the water vapor pressure are to be determined.

Analysis From the psychrometric chart in Fig. A-31E or using EES psychrometric functions we obtain

$$(a) \phi = 0.615 = 61.5\%$$

$$(b) \omega = 0.0188 \text{ lbm H}_2\text{O} / \text{lbm dry air}$$

$$(c) h = 42.3 \text{ Btu/lbm dry air}$$

$$(d) T_{\text{wb}} = 78.9^\circ\text{F}$$

$$(e) P_v = \phi P_g = \phi P_{\text{sat @ } 28^\circ\text{C}} = (0.615)(0.69904 \text{ psia}) = 0.430 \text{ psia}$$

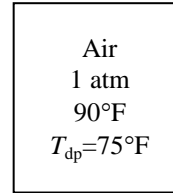

14-44E The pressure, temperature, and wet-bulb temperature of air are specified. The adiabatic saturation temperature is to be determined.

Analysis For an adiabatic saturation process, we obtained Eq. 14-14 in the text,

$$\omega_1 = \frac{c_p(T_2 - T_1) + \omega_2 h_{fg2}}{h_{g1} - h_{f2}}$$

This requires a trial-error solution for the adiabatic saturation temperature, T_2 . The inlet state properties are

$$\omega_1 = 0.0188 \text{ lbm H}_2\text{O} / \text{lbm dry air} \quad (\text{Fig. A-31E})$$

$$h_{g1} = h_g @ 90^\circ\text{F} = 1100.4 \text{ Btu/lbm} \quad (\text{Table A-4E})$$

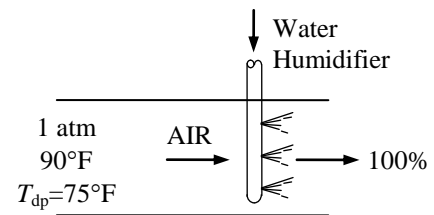

As a first estimate, let us take $T_2 = 78.9^\circ\text{F} \approx 79^\circ\text{F}$ (the inlet wet-bulb temperature). Also, at the exit, the relative humidity is 100% ($\phi_2 = 1$) and the pressure is 1 atm. Other properties at the exit state are

$$\omega_2 = 0.0215 \text{ lbm H}_2\text{O} / \text{lbm dry air}$$

$$h_{f2} = h_f @ 79^\circ\text{F} = 47.07 \text{ Btu/lbm} \quad (\text{Table A-4E})$$

$$h_{fg2} = h_{fg} @ 79^\circ\text{F} = 1048.6 \text{ Btu/lbm} \quad (\text{Table A-4E})$$

Substituting,

$$\omega_1 = \frac{c_p(T_2 - T_1) + \omega_2 h_{fg2}}{h_{g1} - h_{f2}} = \frac{(0.240)(79 - 90) + (0.0215)(1048.6)}{1100.4 - 47.07} = 0.0189 \text{ lbm H}_2\text{O} / \text{lbm dry air}$$

which is sufficiently close to the inlet specific humidity (0.0188). Therefore, the adiabatic saturation temperature is

$$T_2 \cong 79^\circ\text{F}$$

Discussion This result is not surprising since the wet-bulb and adiabatic saturation temperatures are approximately equal to each other for air-water mixtures at atmospheric pressure.

Human Comfort and Air-Conditioning

14-45C It humidifies, dehumidifies, cleans and even deodorizes the air.

14-46C (a) Perspires more, (b) cuts the blood circulation near the skin, and (c) sweats excessively.

14-47C It is the direct heat exchange between the body and the surrounding surfaces. It can make a person feel chilly in winter, and hot in summer.

14-48C It affects by removing the warm, moist air that builds up around the body and replacing it with fresh air.

14-49C The spectators. Because they have a lower level of activity, and thus a lower level of heat generation within their bodies.

14-50C Because they have a large skin area to volume ratio. That is, they have a smaller volume to generate heat but a larger area to lose it from.

14-51C It affects a body's ability to perspire, and thus the amount of heat a body can dissipate through evaporation.

14-52C Humidification is to add moisture into an environment, dehumidification is to remove it.

14-53C The metabolism refers to the burning of foods such as carbohydrates, fat, and protein in order to perform the necessary bodily functions. The metabolic rate for an average man ranges from 108 W while reading, writing, typing, or listening to a lecture in a classroom in a seated position to 1250 W at age 20 (730 at age 70) during strenuous exercise. The corresponding rates for women are about 30 percent lower. Maximum metabolic rates of trained athletes can exceed 2000 W. We are interested in metabolic rate of the occupants of a building when we deal with heating and air conditioning because the metabolic rate represents the rate at which a body generates heat and dissipates it to the room. This body heat contributes to the heating in winter, but it adds to the cooling load of the building in summer.

14-54C Sensible heat is the energy associated with a temperature change. The sensible heat loss from a human body increases as (a) the skin temperature increases, (b) the environment temperature decreases, and (c) the air motion (and thus the convection heat transfer coefficient) increases.

14-55C Latent heat is the energy released as water vapor condenses on cold surfaces, or the energy absorbed from a warm surface as liquid water evaporates. The latent heat loss from a human body increases as (a) the skin wetness increases and (b) the relative humidity of the environment decreases. The rate of evaporation from the body is related to the rate of latent heat loss by $\dot{Q}_{\text{latent}} = \dot{m}_{\text{vapor}} h_{fg}$ where h_{fg} is the latent heat of vaporization of water at the skin temperature.

14-56 A department store expects to have a specified number of people at peak times in summer. The contribution of people to the sensible, latent, and total cooling load of the store is to be determined.

Assumptions There is a mix of men, women, and children in the classroom.

Properties The average rate of heat generation from people doing light work is 115 W, and 70% of is in sensible form (see Sec. 14-6).

Analysis The contribution of people to the sensible, latent, and total cooling load of the store are

$$\begin{aligned}\dot{Q}_{\text{people,total}} &= (\text{No. of people}) \times \dot{Q}_{\text{person,total}} = 245 \times (115 \text{ W}) = \mathbf{28,180 \text{ W}} \\ \dot{Q}_{\text{people,sensible}} &= (\text{No. of people}) \times \dot{Q}_{\text{person,sensible}} = 245 \times (0.7 \times 115 \text{ W}) = \mathbf{19,720 \text{ W}} \\ \dot{Q}_{\text{people,latent}} &= (\text{No. of people}) \times \dot{Q}_{\text{person,latent}} = 245 \times (0.3 \times 115 \text{ W}) = \mathbf{8450 \text{ W}}\end{aligned}$$

14-57E There are a specified number of people in a movie theater in winter. It is to be determined if the theater needs to be heated or cooled.

Assumptions There is a mix of men, women, and children in the classroom.

Properties The average rate of heat generation from people in a movie theater is 105 W, and 70 W of it is in sensible form and 35 W in latent form.

Analysis Noting that only the sensible heat from a person contributes to the heating load of a building, the contribution of people to the heating of the building is

$$\dot{Q}_{\text{people,sensible}} = (\text{No. of people}) \times \dot{Q}_{\text{person,sensible}} = 500 \times (70 \text{ W}) = 35,000 \text{ W} = \mathbf{119,420 \text{ Btu/h}}$$

since $1 \text{ W} = 3.412 \text{ Btu/h}$. The building needs to be heated since the heat gain from people is less than the rate of heat loss of 130,000 Btu/h from the building.

14-58 The infiltration rate of a building is estimated to be 1.2 ACH. The sensible, latent, and total infiltration heat loads of the building at sea level are to be determined.

Assumptions **1** Steady operating conditions exist. **2** The air infiltrates at the outdoor conditions, and exfiltrates at the indoor conditions. **3** Excess moisture condenses at room temperature of 24°C. **4** The effect of water vapor on air density is negligible.

Properties The gas constant and the specific heat of air are $R = 0.287 \text{ kPa}\cdot\text{m}^3/\text{kg}\cdot\text{K}$ and $c_p = 1.005 \text{ kJ}/\text{kg}\cdot^\circ\text{C}$ (Table A-2). The heat of vaporization of water at 24°C is $h_{fg} = h_{fg@24^\circ\text{C}} = 2444.1 \text{ kJ}/\text{kg}$ (Table A-4). The properties of the ambient and room air are determined from the psychrometric chart (Fig. A-31 or EES) to be

$$\left. \begin{array}{l} T_{\text{ambient}} = 32^\circ\text{C} \\ \phi_{\text{ambient}} = 35\% \end{array} \right\} w_{\text{ambient}} = 0.01039 \text{ kg}/\text{kg dry air}$$

$$\left. \begin{array}{l} T_{\text{room}} = 24^\circ\text{C} \\ \phi_{\text{room}} = 55\% \end{array} \right\} w_{\text{room}} = 0.01024 \text{ kg}/\text{kg dry air}$$

Analysis Noting that the infiltration of ambient air will cause the air in the cold storage room to be changed 0.9 times every hour, the air will enter the room at a mass flow rate of

$$\rho_{\text{ambient}} = \frac{P_0}{RT_0} = \frac{101.325 \text{ kPa}}{(0.287 \text{ kPa}\cdot\text{m}^3/\text{kg}\cdot\text{K})(32 + 273 \text{ K})} = 1.158 \text{ kg}/\text{m}^3$$

$$\dot{m}_{\text{air}} = \rho_{\text{ambient}} \mathcal{V}_{\text{room}} \text{ACH} = (1.158 \text{ kg}/\text{m}^3)(20 \times 13 \times 3 \text{ m}^3)(1.2 \text{ h}^{-1}) = 1084 \text{ kg}/\text{h} = 0.3010 \text{ kg}/\text{s}$$

Then the sensible, latent, and total infiltration heat loads of the room are determined to be

$$\dot{Q}_{\text{infiltration,sensible}} = \dot{m}_{\text{air}} c_p (T_{\text{ambient}} - T_{\text{room}}) = (0.3010 \text{ kg}/\text{s})(1.005 \text{ kJ}/\text{kg}\cdot^\circ\text{C})(32 - 24)^\circ\text{C} = \mathbf{2.42 \text{ kW}}$$

$$\dot{Q}_{\text{infiltration,latent}} = \dot{m}_{\text{air}} (w_{\text{ambient}} - w_{\text{room}}) h_{fg@24^\circ\text{C}} = (0.3010 \text{ kg}/\text{s})(0.01039 - 0.01024)(2444.1 \text{ kJ}/\text{kg}) = \mathbf{0.110 \text{ kW}}$$

$$\dot{Q}_{\text{infiltration,total}} = \dot{Q}_{\text{infiltration,sensible}} + \dot{Q}_{\text{infiltration,latent}} = 2.42 + 0.110 = \mathbf{2.53 \text{ kW}}$$

Discussion The specific volume of the dry air at the ambient conditions could also be determined from the psychrometric chart at ambient conditions.

14-59 The infiltration rate of a building is estimated to be 1.8 ACH. The sensible, latent, and total infiltration heat loads of the building at sea level are to be determined.

Assumptions 1 Steady operating conditions exist. 2 The air infiltrates at the outdoor conditions, and exfiltrates at the indoor conditions. 3 Excess moisture condenses at room temperature of 24°C. 4 The effect of water vapor on air density is negligible.

Properties The gas constant and the specific heat of air are $R = 0.287 \text{ kPa}\cdot\text{m}^3/\text{kg}\cdot\text{K}$ and $c_p = 1.005 \text{ kJ}/\text{kg}\cdot^\circ\text{C}$ (Table A-2). The heat of vaporization of water at 24°C is $h_{fg} = h_{fg@24^\circ\text{C}} = 2444.1 \text{ kJ}/\text{kg}$ (Table A-4). The properties of the ambient and room air are determined from the psychrometric chart (Fig. A-31) to be

$$\left. \begin{array}{l} T_{\text{ambient}} = 32^\circ\text{C} \\ \phi_{\text{ambient}} = 35\% \end{array} \right\} w_{\text{ambient}} = 0.01039 \text{ kg/kg dry air}$$

$$\left. \begin{array}{l} T_{\text{room}} = 24^\circ\text{C} \\ \phi_{\text{room}} = 55\% \end{array} \right\} w_{\text{room}} = 0.01024 \text{ kg/kg dry air}$$

Analysis Noting that the infiltration of ambient air will cause the air in the cold storage room to be changed 1.8 times every hour, the air will enter the room at a mass flow rate of

$$\rho_{\text{ambient}} = \frac{P_0}{RT_0} = \frac{101.325 \text{ kPa}}{(0.287 \text{ kPa}\cdot\text{m}^3/\text{kg}\cdot\text{K})(32 + 273 \text{ K})} = 1.158 \text{ kg}/\text{m}^3$$

$$\dot{m}_{\text{air}} = \rho_{\text{ambient}} V_{\text{room}} \text{ACH} = (1.158 \text{ kg}/\text{m}^3)(20 \times 13 \times 3 \text{ m}^3)(1.8 \text{ h}^{-1}) = 1625 \text{ kg}/\text{h} = 0.4514 \text{ kg}/\text{s}$$

Then the sensible, latent, and total infiltration heat loads of the room are determined to be

$$\dot{Q}_{\text{infiltration,sensible}} = \dot{m}_{\text{air}} c_p (T_{\text{ambient}} - T_{\text{room}}) = (0.4514 \text{ kg}/\text{s})(1.005 \text{ kJ}/\text{kg}\cdot^\circ\text{C})(32 - 24)^\circ\text{C} = \mathbf{3.63 \text{ kW}}$$

$$\dot{Q}_{\text{infiltration,latent}} = \dot{m}_{\text{air}} (w_{\text{ambient}} - w_{\text{room}}) h_{fg} = (0.4514 \text{ kg}/\text{s})(0.01039 - 0.01024)(2444.1 \text{ kJ}/\text{kg}) = \mathbf{0.166 \text{ kW}}$$

$$\dot{Q}_{\text{infiltration,total}} = \dot{Q}_{\text{infiltration,sensible}} + \dot{Q}_{\text{infiltration,latent}} = 3.63 + 0.166 = \mathbf{3.80 \text{ kW}}$$

Discussion The specific volume of the dry air at the ambient conditions could also be determined from the psychrometric chart at ambient conditions.

14-60 An average person produces 0.25 kg of moisture while taking a shower. The contribution of showers of a family of four to the latent heat load of the air-conditioner per day is to be determined.

Assumptions All the water vapor from the shower is condensed by the air-conditioning system.

Properties The latent heat of vaporization of water is given to be 2450 kJ/kg.

Analysis The amount of moisture produced per day is

$$\begin{aligned} \dot{m}_{\text{vapor}} &= (\text{Moisture produced per person})(\text{No. of persons}) \\ &= (0.25 \text{ kg / person})(4 \text{ persons / day}) = 1 \text{ kg / day} \end{aligned}$$

Then the latent heat load due to showers becomes

$$\dot{Q}_{\text{latent}} = \dot{m}_{\text{vapor}} h_{fg} = (1 \text{ kg / day})(2450 \text{ kJ / kg}) = \mathbf{2450 \text{ kJ / day}}$$

14-61 There are 100 chickens in a breeding room. The rate of total heat generation and the rate of moisture production in the room are to be determined.

Assumptions All the moisture from the chickens is condensed by the air-conditioning system.

Properties The latent heat of vaporization of water is given to be 2430 kJ/kg. The average metabolic rate of chicken during normal activity is 10.2 W (3.78 W sensible and 6.42 W latent).

Analysis The total rate of heat generation of the chickens in the breeding room is

$$\dot{Q}_{\text{gen, total}} = \dot{q}_{\text{gen, total}} (\text{No. of chickens}) = (10.2 \text{ W/chicken})(100 \text{ chickens}) = \mathbf{1020 \text{ W}}$$

The latent heat generated by the chicken and the rate of moisture production are

$$\begin{aligned} \dot{Q}_{\text{gen, latent}} &= \dot{q}_{\text{gen, latent}} (\text{No. of chickens}) \\ &= (6.42 \text{ W/chicken})(100 \text{ chickens}) = 642 \text{ W} \\ &= 0.642 \text{ kW} \end{aligned}$$

$$\dot{m}_{\text{moisture}} = \frac{\dot{Q}_{\text{gen, latent}}}{h_{fg}} = \frac{0.642 \text{ kJ/s}}{2430 \text{ kJ/kg}} = 0.000264 \text{ kg/s} = \mathbf{0.264 \text{ g/s}}$$

Simple Heating and Cooling

14-62C Relative humidity decreases during a simple heating process and increases during a simple cooling process. Specific humidity, on the other hand, remains constant in both cases.

14-63C Because a horizontal line on the psychrometric chart represents a $\omega = \text{constant}$ process, and the moisture content ω of air remains constant during these processes.

14-64 Air enters a heating section at a specified state and relative humidity. The rate of heat transfer in the heating section and the relative humidity of the air at the exit are to be determined.

Assumptions 1 This is a steady-flow process and thus the mass flow rate of dry air remains constant during the entire process. **2** Dry air and water vapor are ideal gases. **3** The kinetic and potential energy changes are negligible.

Analysis (a) The amount of moisture in the air remains constant ($\omega_1 = \omega_2$) as it flows through the heating section since the process involves no humidification or dehumidification. The inlet state of the air is completely specified, and the total pressure is 95 kPa. The properties of the air are determined to be

$$P_{v1} = \phi_1 P_{g1} = \phi_1 P_{\text{sat}@12^\circ\text{C}} = (0.3)(1.403 \text{ kPa}) = 0.421 \text{ kPa}$$

$$P_{a1} = P_1 - P_{v1} = 95 - 0.421 = 94.58 \text{ kPa}$$

$$\begin{aligned} \nu_1 &= \frac{R_a T_1}{P_{a1}} = \frac{(0.287 \text{ kPa} \cdot \text{m}^3 / \text{kg} \cdot \text{K})(285 \text{ K})}{94.58 \text{ kPa}} \\ &= 0.8648 \text{ m}^3 / \text{kg dry air} \end{aligned}$$

$$\begin{aligned} \omega_1 &= \frac{0.622 P_{v1}}{P_1 - P_{v1}} = \frac{0.622(0.421 \text{ kPa})}{(95 - 0.421) \text{ kPa}} \\ &= 0.002768 \text{ kg H}_2\text{O/kg dry air} (= \omega_2) \end{aligned}$$

$$\begin{aligned} h_1 &= c_p T_1 + \omega_1 h_{g1} \\ &= (1.005 \text{ kJ/kg} \cdot ^\circ\text{C})(12^\circ\text{C}) + (0.002768)(2522.9 \text{ kJ/kg}) \\ &= 19.04 \text{ kJ/kg dry air} \end{aligned}$$

and

$$\begin{aligned} h_2 &= c_p T_2 + \omega_2 h_{g2} \\ &= (1.005 \text{ kJ/kg} \cdot ^\circ\text{C})(25^\circ\text{C}) + (0.002768)(2546.5 \text{ kJ/kg}) \\ &= 32.17 \text{ kJ/kg dry air} \end{aligned}$$

Also,

$$\dot{m}_{a1} = \frac{\dot{V}_1}{\nu_1} = \frac{6 \text{ m}^3 / \text{min}}{0.8648 \text{ m}^3 / \text{kg dry air}} = 6.938 \text{ kg/min}$$

Then the rate of heat transfer to the air in the heating section is determined from an energy balance on air in the heating section to be

$$\dot{Q}_{\text{in}} = \dot{m}_a (h_2 - h_1) = (6.938 \text{ kg/min})(32.17 - 19.04) \text{ kJ/kg} = \mathbf{91.1 \text{ kJ/min}}$$

(b) Noting that the vapor pressure of air remains constant ($P_{v2} = P_{v1}$) during a simple heating process, the relative humidity of the air at leaving the heating section becomes

$$\phi_2 = \frac{P_{v2}}{P_{g2}} = \frac{P_{v2}}{P_{\text{sat}@25^\circ\text{C}}} = \frac{0.421 \text{ kPa}}{3.1698 \text{ kPa}} = 0.133 \text{ or } \mathbf{13.3\%}$$

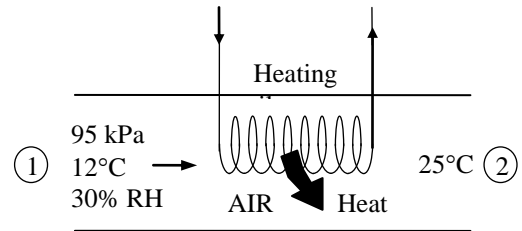

14-65 Humid air at a specified state is cooled at constant pressure to the dew-point temperature. The cooling required for this process is to be determined.

Assumptions **1** This is a steady-flow process and thus the mass flow rate of dry air remains constant during the entire process ($\dot{m}_{a1} = \dot{m}_{a2} = \dot{m}_a$). **2** Dry air and water vapor are ideal gases. **3** The kinetic and potential energy changes are negligible.

Analysis The amount of moisture in the air remains constant ($\omega_1 = \omega_2$) as it flows through the cooling section since the process involves no humidification or dehumidification. The inlet and exit states of the air are completely specified, and the total pressure is 1 atm. The properties of the air at the inlet state are determined from the psychrometric chart (Figure A-31 or EES) to be

$$h_1 = 76.1 \text{ kJ/kg dry air}$$

$$\omega_1 = 0.0159 \text{ kg H}_2\text{O/kg dry air } (= \omega_2)$$

$$T_{dp,1} = 21.3^\circ\text{C}$$

The exit state enthalpy is

$$\left. \begin{array}{l} P = 1 \text{ atm} \\ T_2 = T_{dp,1} = 21.3^\circ\text{C} \\ \phi_2 = 1 \end{array} \right\} h_2 = 61.9 \text{ kJ/kg dry air}$$

From the energy balance on air in the cooling section,

$$q_{\text{out}} = h_1 - h_2 = 76.1 - 61.9 = \mathbf{14.2 \text{ kJ/kg dry air}}$$

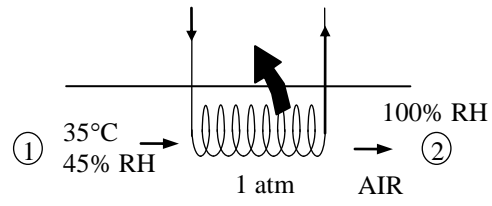

14-66E Humid air at a specified state is heated at constant pressure to a specified temperature. The relative humidity at the exit and the amount of heat required are to be determined.

Assumptions **1** This is a steady-flow process and thus the mass flow rate of dry air remains constant during the entire process ($\dot{m}_{a1} = \dot{m}_{a2} = \dot{m}_a$). **2** Dry air and water vapor are ideal gases. **3** The kinetic and potential energy changes are negligible.

Analysis The amount of moisture in the air remains constant ($\omega_1 = \omega_2$) as it flows through the heating section since the process involves no humidification or dehumidification. The inlet state of the air is completely specified, and the total pressure is 40 psia. The properties of the air at the inlet and exit states are determined to be

$$P_{v1} = \phi_1 P_{g1} = \phi_1 P_{\text{sat}@50^\circ\text{F}} = (0.90)(0.17812 \text{ psia}) = 0.16031 \text{ psia}$$

$$h_{g1} = h_{g@50^\circ\text{F}} = 1083.1 \text{ Btu/lbm}$$

$$\begin{aligned} \omega_1 &= \frac{0.622 P_{v1}}{P_1 - P_{v1}} = \frac{0.622(0.16031 \text{ psia})}{(40 - 0.16031) \text{ psia}} \\ &= 0.002503 \text{ lbm H}_2\text{O/lbm dry air} \end{aligned}$$

$$\begin{aligned} h_1 &= c_p T_1 + \omega_1 h_{g1} \\ &= (0.240 \text{ Btu/lbm}\cdot^\circ\text{F})(50^\circ\text{F}) + (0.002503)(1083.1 \text{ Btu/lbm}) \\ &= 14.71 \text{ Btu/lbm dry air} \end{aligned}$$

$$P_{v2} = P_{v1} = 0.16031 \text{ psia}$$

$$P_{g2} = P_{\text{sat}@120^\circ\text{F}} = 1.6951 \text{ psia}$$

$$\phi_2 = \frac{P_{v2}}{P_{g2}} = \frac{0.16031 \text{ psia}}{1.6951 \text{ psia}} = 0.0946 = \mathbf{9.46\%}$$

$$h_{g2} = h_{g@120^\circ\text{F}} = 1113.2 \text{ Btu/lbm}$$

$$\omega_2 = \omega_1$$

$$\begin{aligned} h_2 &= c_p T_2 + \omega_2 h_{g2} \\ &= (0.240 \text{ Btu/lbm}\cdot^\circ\text{F})(120^\circ\text{F}) + (0.002503)(1113.2 \text{ Btu/lbm}) \\ &= 31.59 \text{ Btu/lbm dry air} \end{aligned}$$

From the energy balance on air in the heating section,

$$q_{\text{in}} = h_2 - h_1 = 31.59 - 14.71 = \mathbf{16.9 \text{ Btu/lbm dry air}}$$

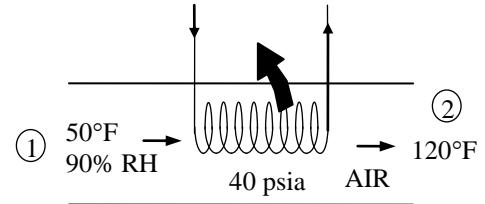

14-67 Air enters a cooling section at a specified pressure, temperature, velocity, and relative humidity. The exit temperature, the exit relative humidity of the air, and the exit velocity are to be determined.

Assumptions 1 This is a steady-flow process and thus the mass flow rate of dry air remains constant during the entire process ($\dot{m}_{a1} = \dot{m}_{a2} = \dot{m}_a$). **2** Dry air and water vapor are ideal gases. **3** The kinetic and potential energy changes are negligible.

Analysis (a) The amount of moisture in the air remains constant ($\omega_1 = \omega_2$) as it flows through the cooling section since the process involves no humidification or dehumidification. The inlet state of the air is completely specified, and the total pressure is 1 atm. The properties of the air at the inlet state are determined from the psychrometric chart (Figure A-31 or EES) to be

$$\begin{aligned} h_1 &= 76.14 \text{ kJ/kg dry air} \\ \omega_1 &= 0.01594 \text{ kg H}_2\text{O/kg dry air} (= \omega_2) \\ \nu_1 &= 0.8953 \text{ m}^3 / \text{kg dry air} \end{aligned}$$

The mass flow rate of dry air through the cooling section is

$$\begin{aligned} \dot{m}_a &= \frac{1}{\nu_1} V_1 A_1 \\ &= \frac{1}{(0.8953 \text{ m}^3 / \text{kg})} (18 \text{ m/s})(\pi \times 0.3^2 / 4 \text{ m}^2) \\ &= 1.421 \text{ kg/s} \end{aligned}$$

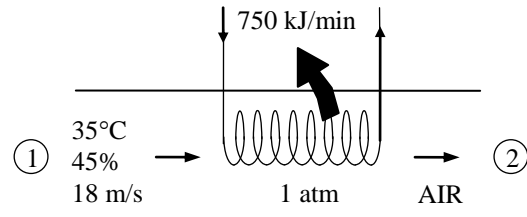

From the energy balance on air in the cooling section,

$$\begin{aligned} -\dot{Q}_{\text{out}} &= \dot{m}_a (h_2 - h_1) \\ -(750 / 60) \text{ kJ/s} &= (1.421 \text{ kg/s})(h_2 - 76.14) \text{ kJ/kg} \\ h_2 &= 67.35 \text{ kJ/kg dry air} \end{aligned}$$

(b) The exit state of the air is fixed now since we know both h_2 and ω_2 . From the psychrometric chart at this state we read

$$\begin{aligned} T_2 &= \mathbf{26.5^\circ\text{C}} \\ \phi_2 &= \mathbf{73.1\%} \\ \nu_2 &= 0.8706 \text{ m}^3 / \text{kg dry air} \end{aligned}$$

(c) The exit velocity is determined from the conservation of mass of dry air,

$$\begin{aligned} \dot{m}_{a1} = \dot{m}_{a2} &\longrightarrow \frac{\dot{V}_1}{\nu_1} = \frac{\dot{V}_2}{\nu_2} \longrightarrow \frac{V_1 A}{\nu_1} = \frac{V_2 A}{\nu_2} \\ V_2 &= \frac{\nu_2}{\nu_1} V_1 = \frac{0.8706}{0.8953} (18 \text{ m/s}) = \mathbf{17.5 \text{ m/s}} \end{aligned}$$

14-68 Air enters a cooling section at a specified pressure, temperature, velocity, and relative humidity. The exit temperature, the exit relative humidity of the air, and the exit velocity are to be determined.

Assumptions 1 This is a steady-flow process and thus the mass flow rate of dry air remains constant during the entire process ($\dot{m}_{a1} = \dot{m}_{a2} = \dot{m}_a$). **2** Dry air and water vapor are ideal gases. **3** The kinetic and potential energy changes are negligible.

Analysis (a) The amount of moisture in the air remains constant ($\omega_1 = \omega_2$) as it flows through the cooling section since the process involves no humidification or dehumidification. The inlet state of the air is completely specified, and the total pressure is 1 atm. The properties of the air at the inlet state are determined from the psychrometric chart (Figure A-31 or EES) to be

$$\begin{aligned} h_1 &= 76.14 \text{ kJ/kg dry air} \\ \omega_1 &= 0.01594 \text{ kg H}_2\text{O/kg dry air} (= \omega_2) \\ \nu_1 &= 0.8953 \text{ m}^3 / \text{kg dry air} \end{aligned}$$

The mass flow rate of dry air through the cooling section is

$$\begin{aligned} \dot{m}_a &= \frac{1}{\nu_1} V_1 A_1 \\ &= \frac{1}{(0.8953 \text{ m}^3 / \text{kg})} (18 \text{ m/s})(\pi \times 0.3^2 / 4 \text{ m}^2) \\ &= 1.421 \text{ kg/s} \end{aligned}$$

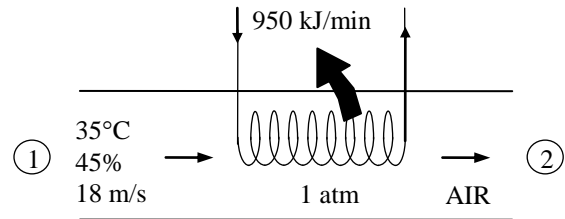

From the energy balance on air in the cooling section,

$$\begin{aligned} -\dot{Q}_{\text{out}} &= \dot{m}_a (h_2 - h_1) \\ -(950 / 60) \text{ kJ/s} &= (1.421 \text{ kg/s})(h_2 - 76.14) \text{ kJ/kg} \\ h_2 &= 65.00 \text{ kJ/kg dry air} \end{aligned}$$

(b) The exit state of the air is fixed now since we know both h_2 and ω_2 . From the psychrometric chart (or EES) at this state we read

$$\begin{aligned} T_2 &= \mathbf{24.3^\circ\text{C}} \\ \phi_2 &= \mathbf{83.6\%} \\ \nu_2 &= 0.8641 \text{ m}^3 / \text{kg dry air} \end{aligned}$$

(c) The exit velocity is determined from the conservation of mass of dry air,

$$\begin{aligned} \dot{m}_{a1} = \dot{m}_{a2} &\longrightarrow \frac{\dot{V}_1}{\nu_1} = \frac{\dot{V}_2}{\nu_2} \longrightarrow \frac{V_1 A}{\nu_1} = \frac{V_2 A}{\nu_2} \\ V_2 &= \frac{\nu_2}{\nu_1} V_1 = \frac{0.8641}{0.8953} (18 \text{ m/s}) = \mathbf{17.4 \text{ m/s}} \end{aligned}$$

14-69E Air enters a heating section at a specified pressure, temperature, velocity, and relative humidity. The exit temperature of air, the exit relative humidity, and the exit velocity are to be determined.

Assumptions **1** This is a steady-flow process and thus the mass flow rate of dry air remains constant during the entire process ($\dot{m}_{a1} = \dot{m}_{a2} = \dot{m}_a$). **2** Dry air and water vapor are ideal gases. **3** The kinetic and potential energy changes are negligible.

Analysis (a) The amount of moisture in the air remains constant ($\omega_1 = \omega_2$) as it flows through the heating section since the process involves no humidification or dehumidification. The inlet state of the air is completely specified, and the total pressure is 1 atm. The properties of the air at the inlet state are determined from the psychrometric chart (Figure A-31E) to be

$$\begin{aligned} h_1 &= 15.3 \text{ Btu/lbm dry air} \\ \omega_1 &= 0.0030 \text{ lbm H}_2\text{O/lbm dry air} (= \omega_2) \\ \nu_1 &= 12.9 \text{ ft}^3 / \text{lbm dry air} \end{aligned}$$

The mass flow rate of dry air through the heating section is

$$\begin{aligned} \dot{m}_a &= \frac{1}{\nu_1} V_1 A_1 \\ &= \frac{1}{(12.9 \text{ ft}^3 / \text{lbm})} (25 \text{ ft/s}) (\pi \times (15/12)^2 / 4 \text{ ft}^2) = 2.38 \text{ lbm/s} \end{aligned}$$

From the energy balance on air in the heating section,

$$\begin{aligned} \dot{Q}_{\text{in}} &= \dot{m}_a (h_2 - h_1) \\ 4 \text{ kW} \left(\frac{0.9478 \text{ Btu/s}}{1 \text{ kW}} \right) &= (2.38 \text{ lbm/s}) (h_2 - 15.3) \text{ Btu/lbm} \\ h_2 &= 16.9 \text{ Btu/lbm dry air} \end{aligned}$$

The exit state of the air is fixed now since we know both h_2 and ω_2 . From the psychrometric chart at this state we read

$$T_2 = \mathbf{56.6^\circ\text{F}}$$

$$(b) \quad \phi_2 = \mathbf{31.4\%}$$

$$\nu_2 = 13.1 \text{ ft}^3 / \text{lbm dry air}$$

(c) The exit velocity is determined from the conservation of mass of dry air,

$$\dot{m}_{a1} = \dot{m}_{a2} \longrightarrow \frac{\dot{V}_1}{\nu_1} = \frac{\dot{V}_2}{\nu_2} \longrightarrow \frac{V_1 A}{\nu_1} = \frac{V_2 A}{\nu_2}$$

Thus,

$$V_2 = \frac{\nu_2}{\nu_1} V_1 = \frac{13.1}{12.9} (25 \text{ ft/s}) = \mathbf{25.4 \text{ ft/s}}$$

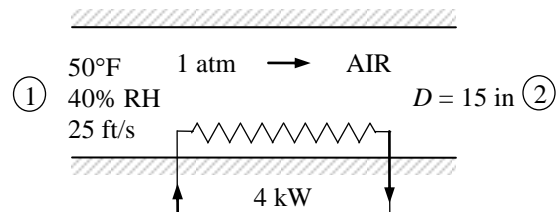

Heating with Humidification

14-70C To achieve a higher level of comfort. Very dry air can cause dry skin, respiratory difficulties, and increased static electricity.

14-71 Air is first heated and then humidified by water vapor. The amount of steam added to the air and the amount of heat transfer to the air are to be determined.

Assumptions 1 This is a steady-flow process and thus the mass flow rate of dry air remains constant during the entire process ($\dot{m}_{a1} = \dot{m}_{a2} = \dot{m}_a$). **2** Dry air and water vapor are ideal gases. **3** The kinetic and potential energy changes are negligible.

Properties The inlet and the exit states of the air are completely specified, and the total pressure is 1 atm. The properties of the air at various states are determined from the psychrometric chart (Figure A-31) to be

$$h_1 = 31.1 \text{ kJ / kg dry air}$$

$$\omega_1 = 0.0064 \text{ kg H}_2\text{O / kg dry air} (= \omega_2)$$

$$h_2 = 36.2 \text{ kJ / kg dry air}$$

$$h_3 = 58.1 \text{ kJ / kg dry air}$$

$$\omega_3 = 0.0129 \text{ kg H}_2\text{O / kg dry air}$$

Analysis (a) The amount of moisture in the air remains constant it flows through the heating section ($\omega_1 = \omega_2$), but increases in the humidifying section ($\omega_3 > \omega_2$). The amount of steam added to the air in the heating section is

$$\Delta\omega = \omega_3 - \omega_2 = 0.0129 - 0.0064 = \mathbf{0.0065 \text{ kg H}_2\text{O / kg dry air}}$$

(b) The heat transfer to the air in the heating section per unit mass of air is

$$q_{\text{in}} = h_2 - h_1 = 36.2 - 31.1 = \mathbf{5.1 \text{ kJ / kg dry air}}$$

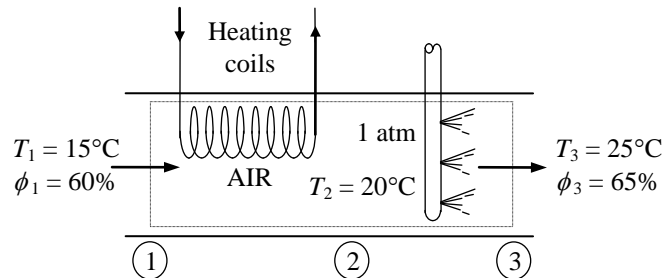

14-72E Air is first heated and then humidified by water vapor. The amount of steam added to the air and the amount of heat transfer to the air are to be determined.

Assumptions 1 This is a steady-flow process and thus the mass flow rate of dry air remains constant during the entire process ($\dot{m}_{a1} = \dot{m}_{a2} = \dot{m}_a$). **2** Dry air and water vapor are ideal gases. **3** The kinetic and potential energy changes are negligible.

Properties The inlet and the exit states of the air are completely specified, and the total pressure is 1 atm. The properties of the air at various states are determined from the psychrometric chart (Figure A-31E or EES) to be

$$\begin{aligned} h_1 &= 10.69 \text{ Btu/lbmdry air} \\ \omega_1 &= 0.002122 \text{ lbm H}_2\text{O/lbm dry air} \\ \omega_2 &= \omega_1 = 0.002122 \text{ lbm H}_2\text{O/lbm dry air} \\ h_2 &= 17.93 \text{ Btu/lbmdry air} \\ h_3 &= 29.16 \text{ Btu/lbmdry air} \\ \omega_3 &= 0.01017 \text{ lbm H}_2\text{O/lbm dry air} \end{aligned}$$

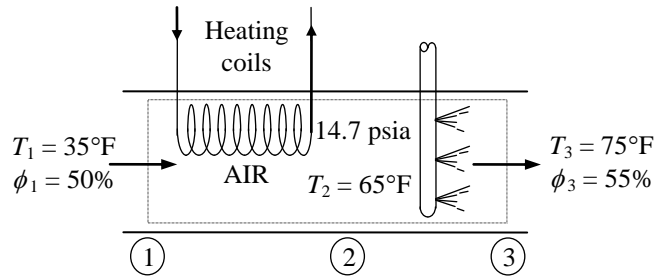

Analysis (a) The amount of moisture in the air remains constant as it flows through the heating section ($\omega_1 = \omega_2$), but increases in the humidifying section ($\omega_3 > \omega_2$). The amount of steam added to the air in the heating section is

$$\Delta\omega = \omega_3 - \omega_2 = 0.01017 - 0.002122 = \mathbf{0.00805 \text{ lbm H}_2\text{O/lbmdry air}}$$

(b) The heat transfer to the air in the heating section per unit mass of air is

$$q_{\text{in}} = h_2 - h_1 = 17.93 - 10.69 = \mathbf{7.24 \text{ Btu/lbmdry air}}$$

14-73 Air is first heated and then humidified by wet steam. The temperature and relative humidity of air at the exit of heating section, the rate of heat transfer, and the rate at which water is added to the air are to be determined.

Assumptions 1 This is a steady-flow process and thus the mass flow rate of dry air remains constant during the entire process ($\dot{m}_{a1} = \dot{m}_{a2} = \dot{m}_a$). **2** Dry air and water vapor are ideal gases. **3** The kinetic and potential energy changes are negligible.

Properties The inlet and the exit states of the air are completely specified, and the total pressure is 1 atm. The properties of the air at various states are determined from the psychrometric chart (Figure A-31) to be

$$h_1 = 23.5 \text{ kJ/kg dry air}$$

$$\omega_1 = 0.0053 \text{ kg H}_2\text{O/kg dry air} (= \omega_2)$$

$$\nu_1 = 0.809 \text{ m}^3/\text{kg dry air}$$

$$h_3 = 42.3 \text{ kJ/kg dry air}$$

$$\omega_3 = 0.0087 \text{ kg H}_2\text{O/kg dry air}$$

Analysis (a) The amount of moisture in the air remains constant it flows through the heating section ($\omega_1 = \omega_2$), but increases in the humidifying section ($\omega_3 > \omega_2$). The mass flow rate of dry air is

$$\dot{m}_a = \frac{\dot{V}_1}{\nu_1} = \frac{35 \text{ m}^3/\text{min}}{0.809 \text{ m}^3/\text{kg}} = 43.3 \text{ kg/min}$$

Noting that $Q = W = 0$, the energy balance on the humidifying section can be expressed as

$$\dot{E}_{\text{in}} - \dot{E}_{\text{out}} = \Delta \dot{E}_{\text{system}} \stackrel{\text{no (steady)}}{=} 0$$

$$\dot{E}_{\text{in}} = \dot{E}_{\text{out}}$$

$$\begin{aligned} \sum \dot{m}_i h_i = \sum \dot{m}_e h_e &\longrightarrow \dot{m}_w h_w + \dot{m}_a h_2 = \dot{m}_a h_3 \\ (\omega_3 - \omega_2) h_w + h_2 &= h_3 \end{aligned}$$

Solving for h_2 ,

$$h_2 = h_3 - (\omega_3 - \omega_2) h_{g@100^\circ\text{C}} = 42.3 - (0.0087 - 0.0053)(2675.6) = 33.2 \text{ kJ/kg dry air}$$

Thus at the exit of the heating section we have $\omega_2 = 0.0053 \text{ kg H}_2\text{O dry air}$ and $h_2 = 33.2 \text{ kJ/kg dry air}$, which completely fixes the state. Then from the psychrometric chart we read

$$T_2 = \mathbf{19.5^\circ\text{C}}$$

$$\phi_2 = \mathbf{37.8\%}$$

(b) The rate of heat transfer to the air in the heating section is

$$\dot{Q}_{\text{in}} = \dot{m}_a (h_2 - h_1) = (43.3 \text{ kg/min})(33.2 - 23.5) \text{ kJ/kg} = \mathbf{420 \text{ kJ/min}}$$

(c) The amount of water added to the air in the humidifying section is determined from the conservation of mass equation of water in the humidifying section,

$$\dot{m}_w = \dot{m}_a (\omega_3 - \omega_2) = (43.3 \text{ kg/min})(0.0087 - 0.0053) = \mathbf{0.15 \text{ kg/min}}$$

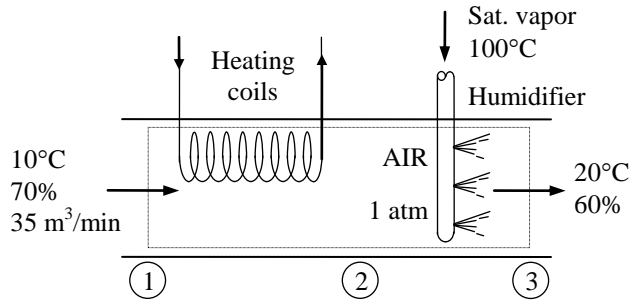

14-74 Air is first heated and then humidified by wet steam. The temperature and relative humidity of air at the exit of heating section, the rate of heat transfer, and the rate at which water is added to the air are to be determined.

Assumptions 1 This is a steady-flow process and thus the mass flow rate of dry air remains constant during the entire process ($\dot{m}_{a1} = \dot{m}_{a2} = \dot{m}_a$).

2 Dry air and water vapor are ideal gases. **3** The kinetic and potential energy changes are negligible.

Analysis (a) The amount of moisture in the air also remains constant it flows through the heating section ($\omega_1 = \omega_2$), but increases in the humidifying section ($\omega_3 > \omega_2$). The inlet and the exit states of the air are completely specified, and the total pressure is 95 kPa. The properties of the air at various states are determined to be

$$P_{v1} = \phi_1 P_{g1} = \phi_1 P_{\text{sat}@10^\circ\text{C}} = (0.70)(1.2281 \text{ kPa}) = 0.860 \text{ kPa} (= P_{v2})$$

$$P_{a1} = P_1 - P_{v1} = 95 - 0.860 = 94.14 \text{ kPa}$$

$$\nu_1 = \frac{R_a T_1}{P_{a1}} = \frac{(0.287 \text{ kPa} \cdot \text{m}^3 / \text{kg} \cdot \text{K})(283 \text{ K})}{94.14 \text{ kPa}} = 0.863 \text{ m}^3 / \text{kg dry air}$$

$$\omega_1 = \frac{0.622 P_{v1}}{P_1 - P_{v1}} = \frac{0.622(0.86 \text{ kPa})}{(95 - 0.86) \text{ kPa}} = 0.00568 \text{ kg H}_2\text{O/kg dry air} (= \omega_2)$$

$$h_1 = c_p T_1 + \omega_1 h_{g1} = (1.005 \text{ kJ/kg} \cdot ^\circ\text{C})(10^\circ\text{C}) + (0.00568)(2519.2 \text{ kJ/kg}) = 24.36 \text{ kJ/kg dry air}$$

$$P_{v3} = \phi_3 P_{g3} = \phi_3 P_{\text{sat}@20^\circ\text{C}} = (0.60)(2.3392 \text{ kPa}) = 1.40 \text{ kPa}$$

$$\omega_3 = \frac{0.622 P_{v3}}{P_3 - P_{v3}} = \frac{0.622(1.40 \text{ kPa})}{(95 - 1.40) \text{ kPa}} = 0.00930 \text{ kg H}_2\text{O/kg dry air}$$

$$h_3 = c_p T_3 + \omega_3 h_{g3} = (1.005 \text{ kJ/kg} \cdot ^\circ\text{C})(20^\circ\text{C}) + (0.0093)(2537.4 \text{ kJ/kg}) = 43.70 \text{ kJ/kg dry air}$$

Also,
$$\dot{m}_a = \frac{\dot{V}_1}{\nu_1} = \frac{35 \text{ m}^3 / \text{min}}{0.863 \text{ m}^3 / \text{kg}} = 40.6 \text{ kg/min}$$

Noting that $Q = W = 0$, the energy balance on the humidifying section gives

$$\dot{E}_{\text{in}} - \dot{E}_{\text{out}} = \Delta \dot{E}_{\text{system}} \stackrel{\text{steady}}{\approx} 0 \longrightarrow \dot{E}_{\text{in}} = \dot{E}_{\text{out}}$$

$$\sum \dot{m}_e h_e = \sum \dot{m}_i h_i \longrightarrow \dot{m}_w h_w + \dot{m}_a h_2 = \dot{m}_a h_3 \longrightarrow (\omega_3 - \omega_2) h_w + h_2 = h_3$$

$$h_2 = h_3 - (\omega_3 - \omega_2) h_{g@100^\circ\text{C}} = 43.7 - (0.0093 - 0.00568) \times 2675.6 = 34.0 \text{ kJ/kg dry air}$$

Thus at the exit of the heating section we have $\omega = 0.00568 \text{ kg H}_2\text{O dry air}$ and $h_2 = 34.0 \text{ kJ/kg dry air}$, which completely fixes the state. The temperature of air at the exit of the heating section is determined from the definition of enthalpy,

$$h_2 = c_p T_2 + \omega_2 h_{g2} \cong c_p T_2 + \omega_2 (2500.9 + 1.82 T_2)$$

$$34.0 = (1.005) T_2 + (0.00568)(2500.9 + 1.82 T_2)$$

Solving for h_2 , yields

$$T_2 = \mathbf{19.5^\circ\text{C}}$$

The relative humidity at this state is

$$\phi_2 = \frac{P_{v2}}{P_{g2}} = \frac{P_{v2}}{P_{\text{sat}@19.5^\circ\text{C}}} = \frac{0.860 \text{ kPa}}{2.2759 \text{ kPa}} = 0.377 \text{ or } \mathbf{37.7\%}$$

(b) The rate of heat transfer to the air in the heating section becomes

$$\dot{Q}_{\text{in}} = \dot{m}_a (h_2 - h_1) = (40.6 \text{ kg/min})(34.0 - 24.36) \text{ kJ/kg} = \mathbf{391 \text{ kJ/min}}$$

(c) The amount of water added to the air in the humidifying section is determined from the conservation of mass equation of water in the humidifying section,

$$\dot{m}_w = \dot{m}_a (\omega_3 - \omega_2) = (40.6 \text{ kg/min})(0.0093 - 0.00568) = \mathbf{0.147 \text{ kg/min}}$$

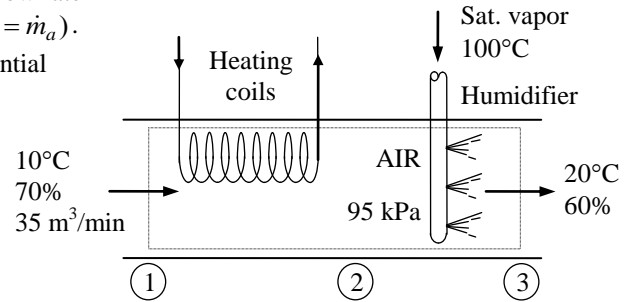

Cooling with Dehumidification

14-75C To drop its relative humidity to more desirable levels.

14-76 Air is cooled and dehumidified by a window air conditioner. The rates of heat and moisture removal from the air are to be determined.

Assumptions 1 This is a steady-flow process and thus the mass flow rate of dry air remains constant during the entire process ($\dot{m}_{a1} = \dot{m}_{a2} = \dot{m}_a$). **2** Dry air and water vapor are ideal gases. **3** The kinetic and potential energy changes are negligible.

Properties The inlet and the exit states of the air are completely specified, and the total pressure is 1 atm. The properties of the air at various states are determined from the psychrometric chart (Figure A-31) to be

$$h_1 = 86.3 \text{ kJ/kg dry air}$$

$$\omega_1 = 0.0211 \text{ kg H}_2\text{O/kg dry air}$$

$$\nu_1 = 0.894 \text{ m}^3/\text{kg dry air}$$

and

$$h_2 = 42.0 \text{ kJ/kg dry air}$$

$$\omega_2 = 0.0107 \text{ kg H}_2\text{O/kg dry air}$$

Also,

$$h_w \cong h_f @ 15^\circ\text{C} = 62.982 \text{ kJ/kg} \quad (\text{Table A-4})$$

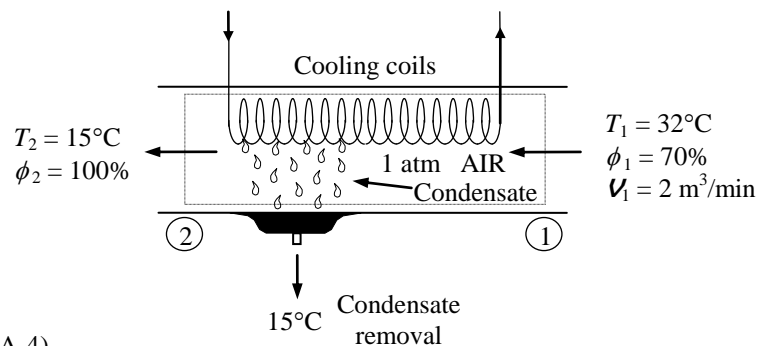

Analysis (a) The amount of moisture in the air decreases due to dehumidification ($\omega_2 < \omega_1$). The mass flow rate of air is

$$\dot{m}_{a1} = \frac{\dot{V}_1}{\nu_1} = \frac{2 \text{ m}^3/\text{min}}{0.894 \text{ m}^3/\text{kg dry air}} = 2.238 \text{ kg/min}$$

Applying the water mass balance and energy balance equations to the combined cooling and dehumidification section,

Water Mass Balance:

$$\sum \dot{m}_{w,i} = \sum \dot{m}_{w,e} \longrightarrow \dot{m}_{a1}\omega_1 = \dot{m}_{a2}\omega_2 + \dot{m}_w$$

$$\dot{m}_w = \dot{m}_a(\omega_1 - \omega_2) = (2.238 \text{ kg/min})(0.0211 - 0.0107) = \mathbf{0.0233 \text{ kg/min}}$$

Energy Balance:

$$\dot{E}_{\text{in}} - \dot{E}_{\text{out}} = \Delta \dot{E}_{\text{system}} \stackrel{\phi=0(\text{steady})}{=} 0$$

$$\dot{E}_{\text{in}} = \dot{E}_{\text{out}}$$

$$\sum \dot{m}_i h_i = \dot{Q}_{\text{out}} + \sum \dot{m}_e h_e$$

$$\dot{Q}_{\text{out}} = \dot{m}_{a1}h_1 - (\dot{m}_{a2}h_2 + \dot{m}_w h_w) = \dot{m}_a(h_1 - h_2) - \dot{m}_w h_w$$

$$\dot{Q}_{\text{out}} = (2.238 \text{ kg/min})(86.3 - 42.0) \text{ kJ/kg} - (0.0233 \text{ kg/min})(62.982 \text{ kJ/kg})$$

$$= \mathbf{97.7 \text{ kJ/min}}$$

14-77E Air is cooled and dehumidified at constant pressure. The amount of water removed from the air and the cooling requirement are to be determined.

Assumptions 1 This is a steady-flow process and thus the mass flow rate of dry air remains constant during the entire process ($\dot{m}_{a1} = \dot{m}_{a2} = \dot{m}_a$). **2** Dry air and water vapor are ideal gases. **3** The kinetic and potential energy changes are negligible.

Properties The inlet and the exit states of the air are completely specified, and the total pressure is 1 atm. The properties of the air at various states are determined from the psychrometric chart (Figure A-31E) to be

$$h_1 = 52.2 \text{ Btu/lbm dry air}$$

$$\omega_1 = 0.0278 \text{ kg H}_2\text{O/kg dry air}$$

and

$$\phi_2 = 1.0$$

$$h_2 = 20.3 \text{ Btu/lbm dry air}$$

$$\omega_2 = 0.0076 \text{ kg H}_2\text{O/kg dry air}$$

Also,

$$h_w \cong h_f @ 60^\circ\text{F} = 28.08 \text{ Btu/lbm} \quad (\text{Table A-4})$$

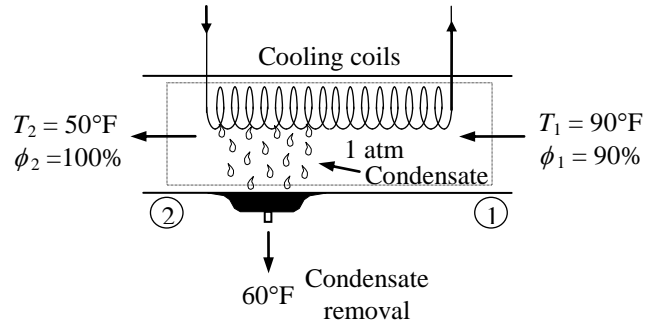

Analysis The amount of moisture in the air decreases due to dehumidification ($\omega_2 < \omega_1$). Applying the water mass balance and energy balance equations to the combined cooling and dehumidification section,

Water Mass Balance:

$$\sum \dot{m}_{w,i} = \sum \dot{m}_{w,e} \longrightarrow \dot{m}_{a1} \omega_1 = \dot{m}_{a2} \omega_2 + \dot{m}_w$$

$$\Delta\omega = \omega_1 - \omega_2 = 0.0278 - 0.0076 = \mathbf{0.0202 \text{ lbm H}_2\text{O/lbm dry air}}$$

Energy Balance:

$$\dot{E}_{\text{in}} - \dot{E}_{\text{out}} = \Delta \dot{E}_{\text{system}} \stackrel{\phi^0(\text{steady})}{=} 0$$

$$\dot{E}_{\text{in}} = \dot{E}_{\text{out}}$$

$$\sum \dot{m}_i h_i = \dot{Q}_{\text{out}} + \sum \dot{m}_e h_e$$

$$\dot{Q}_{\text{out}} = \dot{m}_{a1} h_1 - (\dot{m}_{a2} h_2 + \dot{m}_w h_w) = \dot{m}_a (h_1 - h_2) - \dot{m}_w h_w$$

$$q_{\text{out}} = h_1 - h_2 - (\omega_1 - \omega_2) h_w$$

$$= (52.2 - 20.3) \text{ Btu/lbm} - (0.0202)(28.08)$$

$$= \mathbf{31.3 \text{ Btu/lbm dry air}}$$

14-78  Air is cooled by passing it over a cooling coil through which chilled water flows. The rate of heat transfer, the mass flow rate of water, and the exit velocity of airstream are to be determined.

Assumptions 1 This is a steady-flow process and thus the mass flow rate of dry air remains constant during the entire process. **2** Dry air and water vapor are ideal gases. **3** The kinetic and potential energy changes are negligible.

Analysis (a) The saturation pressure of water at 32°C is 4.76 kPa (Table A-4). Then the dew point temperature of the incoming air stream at 32°C becomes

$$T_{dp} = T_{sat @ P_v} = T_{sat @ 0.7 \times 4.76 \text{ kPa}} = 25.8^\circ\text{C} \quad (\text{Table A-5})$$

since air is cooled to 20°C, which is below its dew point temperature, some of the moisture in the air will condense. The amount of moisture in the air decreases due to dehumidification ($\omega_2 < \omega_1$). The inlet and the exit states of the air are completely specified, and the total pressure is 1 atm. Then the properties of the air at both states are determined from the psychrometric chart (Fig. A-31 or EES) to be

$$h_1 = 86.35 \text{ kJ/kg dry air}$$

$$\omega_1 = 0.02114 \text{ kg H}_2\text{O/kg dry air}$$

$$\nu_1 = 0.8939 \text{ m}^3/\text{kg dry air}$$

and

$$h_2 = 57.43 \text{ kJ/kg dry air}$$

$$\omega_2 = 0.0147 \text{ kg H}_2\text{O/kg dry air}$$

$$\nu_2 = 0.8501 \text{ m}^3/\text{kg dry air}$$

Also, $h_w \cong h_f @ 20^\circ\text{C} = 83.91 \text{ kJ/kg}$ (Table A-4)

Then,

$$\dot{V}_1 = V_1 A_1 = V_1 \frac{\pi D^2}{4} = (120 \text{ m/min}) \left(\frac{\pi (0.4 \text{ m})^2}{4} \right) = 15.08 \text{ m}^3/\text{min}$$

$$\dot{m}_{a1} = \frac{\dot{V}_1}{\nu_1} = \frac{15.08 \text{ m}^3/\text{min}}{0.8939 \text{ m}^3/\text{kg dry air}} = 16.87 \text{ kg/min}$$

Applying the water mass balance and the energy balance equations to the combined cooling and dehumidification section (excluding the water),

$$\text{Water Mass Balance:} \quad \sum \dot{m}_{w,i} = \sum \dot{m}_{w,e} \quad \longrightarrow \quad \dot{m}_{a1} \omega_1 = \dot{m}_{a2} \omega_2 + \dot{m}_w$$

$$\dot{m}_w = \dot{m}_a (\omega_1 - \omega_2) = (16.87 \text{ kg/min})(0.02114 - 0.0147) = 0.1086 \text{ kg/min}$$

$$\text{Energy Balance:} \quad \dot{E}_{in} - \dot{E}_{out} = \Delta \dot{E}_{system} \stackrel{\text{no (steady)}}{\approx} 0 \quad \longrightarrow \quad \dot{E}_{in} = \dot{E}_{out}$$

$$\sum \dot{m}_i h_i = \sum \dot{m}_e h_e + \dot{Q}_{out} \quad \longrightarrow \quad \dot{Q}_{out} = \dot{m}_{a1} h_1 - (\dot{m}_{a2} h_2 + \dot{m}_w h_w) = \dot{m}_a (h_1 - h_2) - \dot{m}_w h_w$$

$$\dot{Q}_{out} = (16.87 \text{ kg/min})(86.35 - 57.43) \text{ kJ/kg} - (0.1086 \text{ kg/min})(83.91 \text{ kJ/kg}) = \mathbf{478.7 \text{ kJ/min}}$$

(b) Noting that the heat lost by the air is gained by the cooling water, the mass flow rate of the cooling water is determined from

$$\dot{Q}_{cooling\ water} = \dot{m}_{cooling\ water} \Delta h = \dot{m}_{cooling\ water} c_p \Delta T$$

$$\dot{m}_{cooling\ water} = \frac{\dot{Q}_w}{c_p \Delta T} = \frac{478.7 \text{ kJ/min}}{(4.18 \text{ kJ/kg} \cdot ^\circ\text{C})(6^\circ\text{C})} = \mathbf{19.09 \text{ kg/min}}$$

(c) The exit velocity is determined from the conservation of mass of dry air,

$$\dot{m}_{a1} = \dot{m}_{a2} \quad \longrightarrow \quad \frac{\dot{V}_1}{\nu_1} = \frac{\dot{V}_2}{\nu_2} \quad \longrightarrow \quad \frac{V_1 A}{\nu_1} = \frac{V_2 A}{\nu_2}$$

$$V_2 = \frac{\nu_2}{\nu_1} V_1 = \frac{0.8501}{0.8939} (120 \text{ m/min}) = \mathbf{114 \text{ m/min}}$$

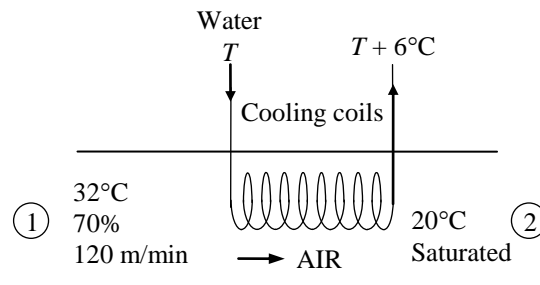



14-79 Problem 14-78 is reconsidered. A general solution of the problem in which the input variables may be supplied and parametric studies performed is to be developed and the process is to be shown in the psychrometric chart for each set of input variables.

Analysis The problem is solved using EES, and the solution is given below.

"Input Data from the Diagram Window"

```
{D=0.4
P[1] =101.32 [kPa]
T[1] = 32 [C]
RH[1] = 70/100 "%, relative humidity"
Vel[1] = 120/60 "[m/s]"
DELTAT_cw =6 [C]
P[2] = 101.32 [kPa]
T[2] = 20 [C]}
RH[2] = 100/100 "%"
```

"Dry air flow rate, m_dot_a, is constant"

```
Vol_dot[1]= (pi * D^2)/4*Vel[1]
v[1]=VOLUME(AirH2O,T=T[1],P=P[1],R=RH[1])
m_dot_a = Vol_dot[1]/v[1]
```

"Exit vleocity"

```
Vol_dot[2]= (pi * D^2)/4*Vel[2]
v[2]=VOLUME(AirH2O,T=T[2],P=P[2],R=RH[2])
m_dot_a = Vol_dot[2]/v[2]
```

"Mass flow rate of the condensed water"

```
m_dot_v[1]=m_dot_v[2]+m_dot_w
w[1]=HUMRAT(AirH2O,T=T[1],P=P[1],R=RH[1])
m_dot_v[1] = m_dot_a*w[1]
w[2]=HUMRAT(AirH2O,T=T[2],P=P[2],R=RH[2])
m_dot_v[2] = m_dot_a*w[2]
```

"SSSF conservation of energy for the air"

```
m_dot_a *(h[1] + (1+w[1])*Vel[1]^2/2*Convert(m^2/s^2, kJ/kg)) + Q_dot = m_dot_a*(h[2]
+(1+w[2])*Vel[2]^2/2*Convert(m^2/s^2, kJ/kg)) +m_dot_w*h_liq_2
h[1]=ENTHALPY(AirH2O,T=T[1],P=P[1],w=w[1])
h[2]=ENTHALPY(AirH2O,T=T[2],P=P[2],w=w[2])
h_liq_2=ENTHALPY(Water,T=T[2],P=P[2])
```

"SSSF conservation of energy for the cooling water"

```
-Q_dot =m_dot_cw*Cp_cw*DELTAT_cw "Note: Q_netwater=-Q_netair"
Cp_cw = SpecHeat(water,T=10,P=P[2])"kJ/kg-K"
```

RH ₁	m _{cw} [kg/s]	Q _{out} [kW]	Vel ₂ [m/s]
0.5	0.1475	3.706	1.921
0.55	0.19	4.774	1.916
0.6	0.2325	5.842	1.911
0.65	0.275	6.91	1.907
0.7	0.3175	7.978	1.902
0.75	0.36	9.046	1.897
0.8	0.4025	10.11	1.893
0.85	0.445	11.18	1.888
0.9	0.4875	12.25	1.884

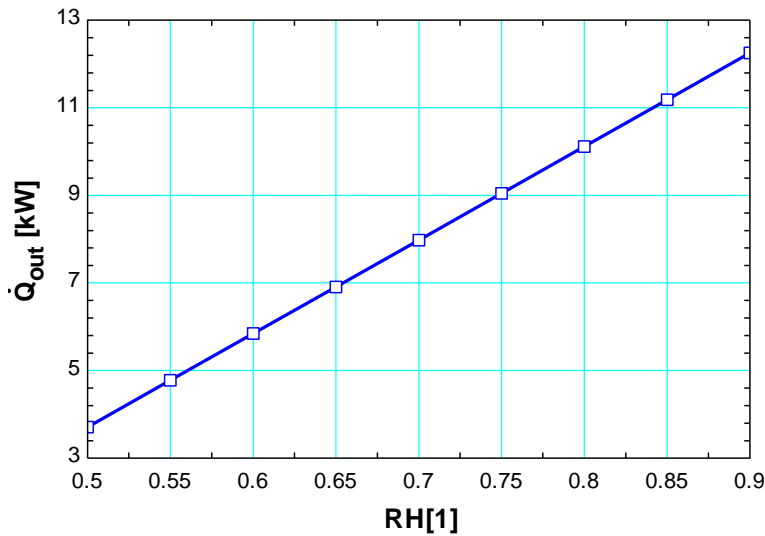
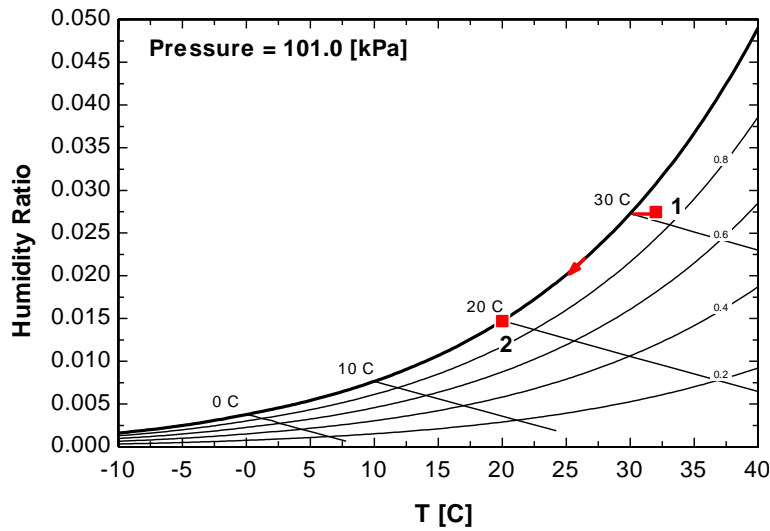

14-80 Air is cooled by passing it over a cooling coil. The rate of heat transfer, the mass flow rate of water, and the exit velocity of airstream are to be determined.

Assumptions 1 This is a steady-flow process and thus the mass flow rate of dry air remains constant during the entire process. **2** Dry air and water vapor are ideal gases. **3** The kinetic and potential energy changes are negligible.

Analysis (a) The dew point temperature of the incoming air stream at 35°C is

$$\begin{aligned} P_{v1} &= \phi_1 P_{g1} = \phi_1 P_{\text{sat}@32^\circ\text{C}} \\ &= (0.7)(4.76 \text{ kPa}) = 3.332 \text{ kPa} \\ T_{\text{dp}} &= T_{\text{sat}@P_v} = T_{\text{sat}@3.332 \text{ kPa}} = 25.8^\circ\text{C} \end{aligned}$$

Since air is cooled to 20°C, which is below its dew point temperature, some of the moisture in the air will condense.

The amount of moisture in the air decreases due to dehumidification ($\omega_2 < \omega_1$). The inlet and the exit states of the air are completely specified, and the total pressure is 95 kPa. Then the properties of the air at both states are determined to be

$$\begin{aligned} P_{a1} &= P_1 - P_{v1} = 95 - 3.332 = 91.67 \text{ kPa} \\ \nu_1 &= \frac{R_a T_1}{P_{a1}} = \frac{(0.287 \text{ kPa} \cdot \text{m}^3 / \text{kg} \cdot \text{K})(305 \text{ K})}{91.67 \text{ kPa}} = 0.9549 \text{ m}^3 / \text{kg dry air} \\ \omega_1 &= \frac{0.622 P_{v1}}{P_1 - P_{v1}} = \frac{0.622(3.332 \text{ kPa})}{(95 - 3.332) \text{ kPa}} = 0.02261 \text{ kg H}_2\text{O/kg dry air} \\ h_1 &= c_p T_1 + \omega_1 h_{g1} = (1.005 \text{ kJ/kg} \cdot ^\circ\text{C})(32^\circ\text{C}) + (0.02261)(2559.2 \text{ kJ/kg}) = 90.01 \text{ kJ/kg dry air} \end{aligned}$$

and

$$\begin{aligned} P_{v2} &= \phi_2 P_{g2} = (1.00)P_{\text{sat}@20^\circ\text{C}} = 2.339 \text{ kPa} \\ \nu_2 &= \frac{R_a T_2}{P_{a2}} = \frac{(0.287 \text{ kPa} \cdot \text{m}^3 / \text{kg} \cdot \text{K})(293 \text{ K})}{(95 - 2.339) \text{ kPa}} = 0.9075 \text{ m}^3 / \text{kg dry air} \\ \omega_2 &= \frac{0.622 P_{v2}}{P_2 - P_{v2}} = \frac{0.622(2.339 \text{ kPa})}{(95 - 2.339) \text{ kPa}} = 0.0157 \text{ kg H}_2\text{O/kg dry air} \\ h_2 &= c_p T_2 + \omega_2 h_{g2} = (1.005 \text{ kJ/kg} \cdot ^\circ\text{C})(20^\circ\text{C}) + (0.0157)(2537.4 \text{ kJ/kg}) = 59.94 \text{ kJ/kg dry air} \end{aligned}$$

Also,

$$h_w \cong h_f @ 20^\circ\text{C} = 83.915 \text{ kJ/kg} \quad (\text{Table A-4})$$

Then,

$$\begin{aligned} \dot{V}_1 &= V_1 A_1 = V_1 \frac{\pi D^2}{4} = (120 \text{ m/min}) \left(\frac{\pi(0.4 \text{ m})^2}{4} \right) = 15.08 \text{ m}^3 / \text{min} \\ \dot{m}_{a1} &= \frac{\dot{V}_1}{\nu_1} = \frac{15.08 \text{ m}^3 / \text{min}}{0.9549 \text{ m}^3 / \text{kg dry air}} = 15.79 \text{ kg/min} \end{aligned}$$

Applying the water mass balance and energy balance equations to the combined cooling and dehumidification section (excluding the water),

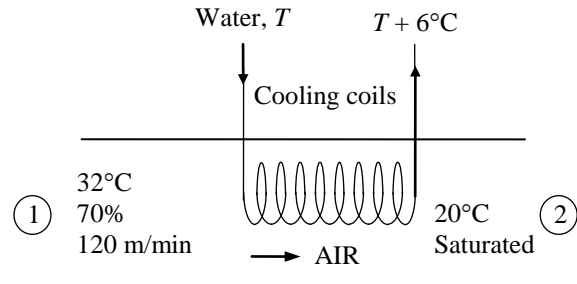

Water Mass Balance:

$$\sum \dot{m}_{w,i} = \sum \dot{m}_{w,e} \longrightarrow \dot{m}_{a1}\omega_1 = \dot{m}_{a2}\omega_2 + \dot{m}_w$$

$$\dot{m}_w = \dot{m}_a(\omega_1 - \omega_2) = (15.79 \text{ kg/min})(0.02261 - 0.0157) = 0.1090 \text{ kg/min}$$

Energy Balance:

$$\dot{E}_{\text{in}} - \dot{E}_{\text{out}} = \Delta \dot{E}_{\text{system}} \stackrel{\text{no (steady)}}{=} 0$$

$$\dot{E}_{\text{in}} = \dot{E}_{\text{out}}$$

$$\sum \dot{m}_i h_i = \sum \dot{m}_e h_e + \dot{Q}_{\text{out}} \rightarrow \dot{Q}_{\text{out}} = \dot{m}_{a1}h_1 - (\dot{m}_{a2}h_2 + \dot{m}_w h_w) = \dot{m}_a(h_1 - h_2) - \dot{m}_w h_w$$

$$\dot{Q}_{\text{out}} = (15.79 \text{ kg/min})(90.01 - 59.94) \text{ kJ/kg} - (0.1090 \text{ kg/min})(83.915 \text{ kJ/kg}) = \mathbf{465.7 \text{ kJ/min}}$$

(b) Noting that the heat lost by the air is gained by the cooling water, the mass flow rate of the cooling water is determined from

$$\dot{Q}_{\text{coolingwater}} = \dot{m}_{\text{coolingwater}} \Delta h = \dot{m}_{\text{coolingwater}} c_p \Delta T$$

$$\dot{m}_{\text{coolingwater}} = \frac{\dot{Q}_w}{c_p \Delta T} = \frac{465.7 \text{ kJ/min}}{(4.18 \text{ kJ/kg} \cdot ^\circ\text{C})(6^\circ\text{C})} = \mathbf{18.57 \text{ kg/min}}$$

(c) The exit velocity is determined from the conservation of mass of dry air,

$$\dot{m}_{a1} = \dot{m}_{a2} \longrightarrow \frac{\dot{V}_1}{\nu_1} = \frac{\dot{V}_2}{\nu_2} \longrightarrow \frac{V_1 A}{\nu_1} = \frac{V_2 A}{\nu_2}$$

$$V_2 = \frac{\nu_2}{\nu_1} V_1 = \frac{0.9075}{0.9549} (120 \text{ m/min}) = \mathbf{114 \text{ m/min}}$$

14-81E Air is cooled by passing it over a cooling coil through which chilled water flows. The rate of heat transfer, the mass flow rate of water, and the exit velocity of airstream are to be determined.

Assumptions 1 This is a steady-flow process and thus the mass flow rate of dry air remains constant during the entire process. **2** Dry air and water vapor are ideal gases. **3** The kinetic and potential energy changes are negligible.

Analysis (a) The saturation pressure of water at 90°F is 0.69904 psia (Table A-4E). Then, the dew point temperature of the incoming air stream at 90°F becomes

$$T_{dp} = T_{sat @ P_v} = T_{sat @ 0.6 \times 0.69904 \text{ psia}} = 74.2^\circ\text{F} \quad (\text{Table A-5E})$$

Since air is cooled to 70°F, which is below its dew point temperature, some of the moisture in the air will condense. The amount of moisture in the air decreases due to dehumidification ($\omega_2 < \omega_1$). The inlet and the exit states of the air are completely specified, and the total pressure is 14.7 psia. Then the properties of the air at both states are determined from the psychrometric chart (Fig. A-31E) to be

$$\begin{aligned} h_1 &= 41.8 \text{ Btu/lbm dry air} \\ \omega_1 &= 0.0183 \text{ lbm H}_2\text{O/lbm dry air} \\ \nu_1 &= 14.26 \text{ ft}^3/\text{lbm dry air} \end{aligned}$$

and

$$\begin{aligned} h_2 &= 34.1 \text{ Btu/lbm dry air} \\ \omega_2 &= 0.0158 \text{ lbm H}_2\text{O/lbm dry air} \\ \nu_2 &= 13.68 \text{ ft}^3/\text{lbm dry air} \end{aligned}$$

Also,

$$h_w \cong h_f @ 70^\circ\text{F} = 38.08 \text{ Btu/lbm} \quad (\text{Table A-4E})$$

$$\dot{V}_1 = V_1 A_1 = V_1 \frac{\pi D^2}{4} = (600 \text{ ft/min}) \left(\frac{\pi (1 \text{ ft})^2}{4} \right) = 471 \text{ ft}^3/\text{min}$$

Then,

$$\dot{m}_{a1} = \frac{\dot{V}_1}{\nu_1} = \frac{471 \text{ ft}^3/\text{min}}{14.26 \text{ ft}^3/\text{lbm dry air}} = 33.0 \text{ lbm/min}$$

Applying the water mass balance and the energy balance equations to the combined cooling and dehumidification section (excluding the water),

$$\text{Water Mass Balance:} \quad \sum \dot{m}_{w,i} = \sum \dot{m}_{w,e} \quad \longrightarrow \quad \dot{m}_{a1} \omega_1 = \dot{m}_{a2} \omega_2 + \dot{m}_w$$

$$\dot{m}_w = \dot{m}_a (\omega_1 - \omega_2) = (33.0 \text{ lbm/min})(0.0183 - 0.0158) = 0.083 \text{ lbm/min}$$

$$\text{Energy Balance:} \quad \dot{E}_{in} - \dot{E}_{out} = \Delta \dot{E}_{system} \stackrel{\text{steady}}{\approx} 0 \quad \longrightarrow \quad \dot{E}_{in} = \dot{E}_{out}$$

$$\sum \dot{m}_i h_i = \sum \dot{m}_e h_e + \dot{Q}_{out} \quad \longrightarrow \quad \dot{Q}_{out} = \dot{m}_a h_1 - (\dot{m}_a h_2 + \dot{m}_w h_w) = \dot{m}_a (h_1 - h_2) - \dot{m}_w h_w$$

$$\dot{Q}_{out} = (33.0 \text{ lbm/min})(41.8 - 34.1) \text{ Btu/lbm} - (0.083 \text{ lbm/min})(38.08 \text{ Btu/lbm}) = \mathbf{250.9 \text{ Btu/min}}$$

(b) Noting that the heat lost by the air is gained by the cooling water, the mass flow rate of the cooling water is determined from

$$\begin{aligned} \dot{Q}_{cooling\ water} &= \dot{m}_{cooling\ water} \Delta h = \dot{m}_{cooling\ water} c_p \Delta T \\ \dot{m}_{cooling\ water} &= \frac{\dot{Q}_w}{c_p \Delta T} = \frac{250.9 \text{ Btu/min}}{(1.0 \text{ Btu/lbm} \cdot ^\circ\text{F})(14^\circ\text{F})} = \mathbf{17.9 \text{ lbm/min}} \end{aligned}$$

(c) The exit velocity is determined from the conservation of mass of dry air,

$$\begin{aligned} \dot{m}_{a1} = \dot{m}_{a2} &\quad \longrightarrow \quad \frac{\dot{V}_1}{\nu_1} = \frac{\dot{V}_2}{\nu_2} \quad \longrightarrow \quad \frac{V_1 A}{\nu_1} = \frac{V_2 A}{\nu_2} \\ V_2 &= \frac{\nu_2}{\nu_1} V_1 = \frac{13.68}{14.26} (600 \text{ ft/min}) = \mathbf{576 \text{ ft/min}} \end{aligned}$$

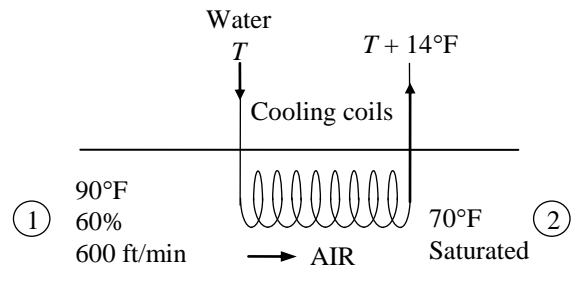



14-82E Problem 14-81E is reconsidered. The effect of the total pressure of the air on the required results is to be studied.

Analysis The problem is solved using EES, and the solution is given below.

"Input Data from the Diagram Window"

```
{D=1.0 [ft]
P[1]=14.7 [psia]
T[1]=90 [F]
RH[1]=60/100 "%, relative humidity"
Vel[1]=600 [ft/min]
DELTAT_cw=14 [F]
P[2]=14.7 [psia]
T[2]=70 [F]}
{P[1]=P
P[2]=P}
Tdp_1=DEWPOINT(AirH2O,T=T[1],P=P[1],w=w[1])
RH[2]=100/100 "%"
```

"Dry air flow rate, m_dot_a, is constant"

```
Vol_dot[1]=(pi * D^2)/4*Vel[1]
v[1]=VOLUME(AirH2O,T=T[1],P=P[1],R=RH[1])
m_dot_a = Vol_dot[1]/v[1]
```

"Exit vleocity"

```
Vol_dot[2]=(pi * D^2)/4*Vel[2]
v[2]=VOLUME(AirH2O,T=T[2],P=P[2],R=RH[2])
m_dot_a = Vol_dot[2]/v[2]
```

"Mass flow rate of the condensed water"

```
m_dot_v[1]=m_dot_v[2]+m_dot_w
w[1]=HUMRAT(AirH2O,T=T[1],P=P[1],R=RH[1])
m_dot_v[1] = m_dot_a*w[1]
w[2]=HUMRAT(AirH2O,T=T[2],P=P[2],R=RH[2])
m_dot_v[2] = m_dot_a*w[2]
```

"SSSF conservation of energy for the air"

```
m_dot_a *(h[1] + (1+w[1])*Vel[1]^2/2*convert(ft^2/min^2,Btu/lbm)) = Q_dot+ m_dot_a*(h[2]
+(1+w[2])*Vel[2]^2/2*convert(ft^2/min^2,Btu/lbm)) +m_dot_w*h_liq_2
h[1]=ENTHALPY(AirH2O,T=T[1],P=P[1],w=w[1])
h[2]=ENTHALPY(AirH2O,T=T[2],P=P[2],w=w[2])
h_liq_2=ENTHALPY(Water,T=T[2],P=P[2])
```

"SSSF conservation of energy for the cooling water"

```
Q_dot =m_dot_cw*Cp_cw*DELTAT_cw "Note: Q_netwater=-Q_netair"
Cp_cw = SpecHeat(water,T=60,P=P[2])
```

m _{cw} [lb _m /min]	P [psia]	Q [Btu/min]	Vel ₂ [ft/min]
17.65	14.3	247	575.8
17.81	14.5	249.2	575.9
18.05	14.8	252.5	575.9
18.2	15	254.6	576
18.36	15.2	256.8	576

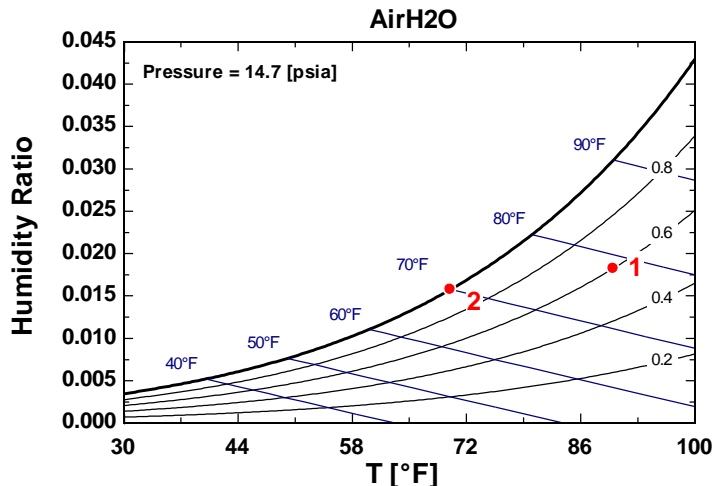

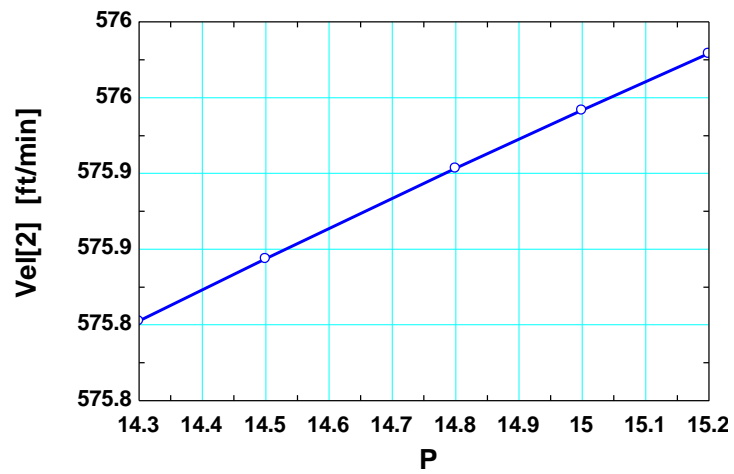
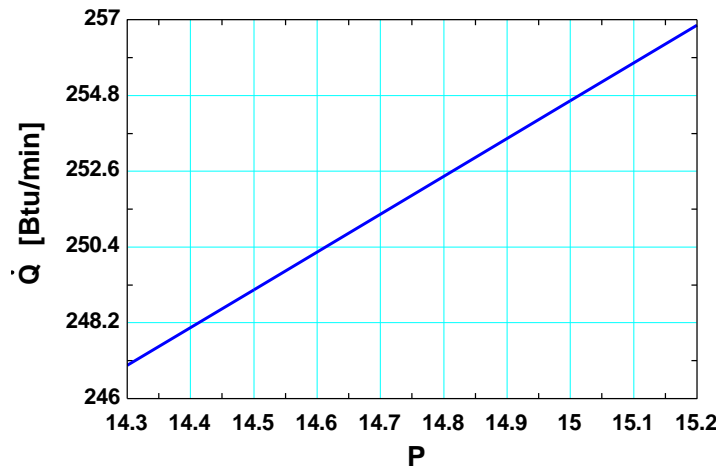
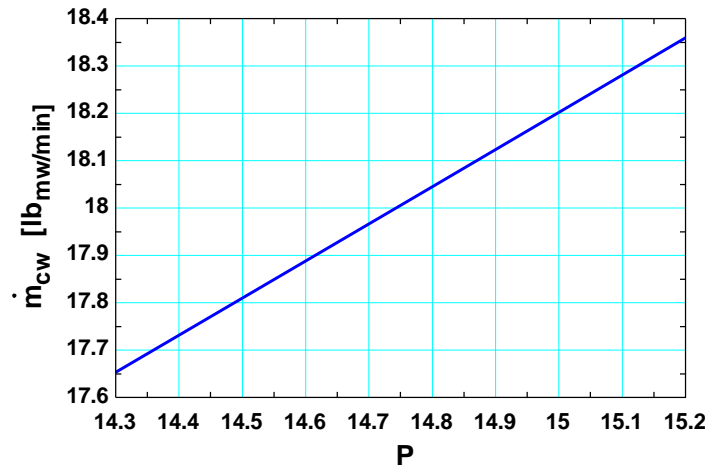

14-83E Air is cooled by passing it over a cooling coil through which chilled water flows. The rate of heat transfer, the mass flow rate of water, and the exit velocity of airstream are to be determined.

Assumptions 1 This is a steady-flow process and thus the mass flow rate of dry air remains constant during the entire process. **2** Dry air and water vapor are ideal gases. **3** The kinetic and potential energy changes are negligible.

Analysis (a) The dew point temperature of the incoming air stream at 90°F is

$$P_{v1} = \phi_1 P_{g1} = \phi_1 P_{\text{sat}@90^\circ\text{F}} = (0.6)(0.69904 \text{ psia}) = 0.42 \text{ psi} \quad (\text{Tables A-4E and A-5E})$$

$$T_{\text{dp}} = T_{\text{sat}@P_v} = T_{\text{sat}@0.42 \text{ psia}} = 74^\circ\text{F}$$

Since air is cooled to 70°F, which is below its dew point temperature, some of the moisture in the air will condense.

The mass flow rate of dry air remains constant during the entire process ($\dot{m}_{a1} = \dot{m}_{a2} = \dot{m}_a$), but the amount of moisture in the air decreases due to dehumidification ($\omega_2 < \omega_1$). The inlet and the exit states of the air are completely specified, and the total pressure is 14.4 psia. Then the properties of the air at both states are determined to be

$$P_{a1} = P_1 - P_{v1} = 14.4 - 0.42 = 13.98 \text{ psia}$$

$$v_1 = \frac{R_a T_1}{P_{a1}} = \frac{(0.3704 \text{ psia} \cdot \text{ft}^3 / \text{lbm} \cdot \text{R})(550 \text{ R})}{13.98 \text{ psia}} = 14.57 \text{ ft}^3 / \text{lbm dry air}$$

$$\omega_1 = \frac{0.622 P_{v1}}{P_1 - P_{v1}} = \frac{0.622(0.42 \text{ psia})}{(14.4 - 0.42) \text{ psia}} = 0.0187 \text{ lbm H}_2\text{O/lbm dry air}$$

$$h_1 = c_p T_1 + \omega_1 h_{g1} = (0.24 \text{ Btu/lbm} \cdot ^\circ\text{F})(90^\circ\text{F}) + (0.0187)(1100.4 \text{ Btu/lbm}) = 42.18 \text{ Btu/lbm dry air}$$

and

$$P_{v2} = \phi_2 P_{g2} = (1.00)P_{\text{sat}@70^\circ\text{F}} = 0.36 \text{ psia}$$

$$P_{a2} = P_2 - P_{v2} = 14.4 - 0.36 = 14.04 \text{ psia}$$

$$v_2 = \frac{R_a T_2}{P_{a2}} = \frac{(0.3704 \text{ psia} \cdot \text{ft}^3 / \text{lbm} \cdot \text{R})(530 \text{ R})}{14.04 \text{ psia}} = 14.0 \text{ ft}^3 / \text{lbm dry air}$$

$$\omega_2 = \frac{0.622 P_{v2}}{P_2 - P_{v2}} = \frac{0.622(0.36 \text{ psia})}{(14.4 - 0.36) \text{ psia}} = 0.0159 \text{ lbm H}_2\text{O/lbm dry air}$$

$$h_2 = c_p T_2 + \omega_2 h_{g2} = (0.24 \text{ Btu/lbm} \cdot ^\circ\text{F})(70^\circ\text{F}) + (0.0159)(1091.8 \text{ Btu/lbm}) = 34.16 \text{ Btu/lbm dry air}$$

Also,

$$h_w \cong h_f @ 70^\circ\text{F} = 38.08 \text{ Btu/lbm} \quad (\text{Table A-4E})$$

Then,

$$\dot{V}_1 = V_1 A_1 = V_1 \frac{\pi D^2}{4} = (600 \text{ ft/min}) \left(\frac{\pi (1 \text{ ft})^2}{4} \right) = 471 \text{ ft}^3 / \text{min}$$

$$\dot{m}_{a1} = \frac{\dot{V}_1}{v_1} = \frac{471 \text{ ft}^3 / \text{min}}{14.57 \text{ ft}^3 / \text{lbm dry air}} = 32.3 \text{ lbm/min}$$

Applying the water mass balance and energy balance equations to the combined cooling and dehumidification section (excluding the water),

Water Mass Balance:

$$\sum \dot{m}_{w,i} = \sum \dot{m}_{w,e} \quad \longrightarrow \quad \dot{m}_{a1} \omega_1 = \dot{m}_{a2} \omega_2 + \dot{m}_w$$

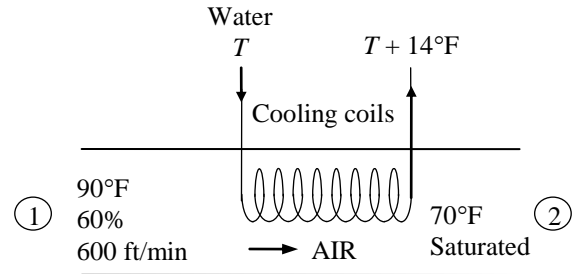

$$\dot{m}_w = \dot{m}_a(\omega_1 - \omega_2) = (32.3 \text{ lbm/min})(0.0187 - 0.0159) = 0.0904 \text{ lbm/min}$$

Energy balance:

$$\dot{E}_{\text{in}} - \dot{E}_{\text{out}} = \Delta \dot{E}_{\text{system}} \stackrel{\approx 0 \text{ (steady)}}{=} 0$$

$$\dot{E}_{\text{in}} = \dot{E}_{\text{out}}$$

$$\sum \dot{m}_i h_i = \sum \dot{m}_e h_e + \dot{Q}_{\text{out}} \rightarrow \dot{Q}_{\text{out}} = \dot{m}_{a1} h_1 - (\dot{m}_{a2} h_2 + \dot{m}_w h_w) = \dot{m}_a (h_1 - h_2) - \dot{m}_w h_w$$

$$\begin{aligned} \dot{Q}_{\text{out}} &= (32.3 \text{ lbm/min})(42.18 - 34.16) \text{ Btu/lbm} - (0.0904 \text{ lbm/min})(38.08 \text{ Btu/lbm}) \\ &= \mathbf{255.6 \text{ Btu/min}} \end{aligned}$$

(b) Noting that the heat lost by the air is gained by the cooling water, the mass flow rate of the cooling water is determined from

$$\dot{Q}_{\text{coolingwater}} = \dot{m}_{\text{coolingwater}} \Delta h = \dot{m}_{\text{coolingwater}} c_p \Delta T$$

$$\dot{m}_{\text{coolingwater}} = \frac{\dot{Q}_w}{c_p \Delta T} = \frac{255.6 \text{ Btu/min}}{(1.0 \text{ Btu/lbm} \cdot ^\circ\text{F})(14^\circ\text{F})} = \mathbf{18.3 \text{ lbm/min}}$$

(c) The exit velocity is determined from the conservation of mass of dry air,

$$\dot{m}_{a1} = \dot{m}_{a2} \longrightarrow \frac{\dot{V}_1}{\nu_1} = \frac{\dot{V}_2}{\nu_2} \longrightarrow \frac{V_1 A}{\nu_1} = \frac{V_2 A}{\nu_2}$$

$$V_2 = \frac{\nu_2}{\nu_1} V_1 = \frac{14.0}{14.57} (600 \text{ ft/s}) = \mathbf{577 \text{ ft/min}}$$

14-84 Air flows through an air conditioner unit. The inlet and exit states are specified. The rate of heat transfer and the mass flow rate of condensate water are to be determined.

Assumptions 1 This is a steady-flow process and thus the mass flow rate of dry air remains constant during the entire process ($\dot{m}_{a1} = \dot{m}_{a2} = \dot{m}_a$). **2** Dry air and water vapor are ideal gases. **3** The kinetic and potential energy changes are negligible.

Analysis The inlet state of the air is completely specified, and the total pressure is 101 kPa. The properties of the air at the inlet state may be determined from (Fig. A-31) or using EES psychrometric functions to be (we used EES)

$$\begin{aligned}h_1 &= 57.20 \text{ kJ/kg dry air} \\ \omega_1 &= 0.01056 \text{ kg H}_2\text{O/kg dry air} \\ \phi_1 &= 0.3972\end{aligned}$$

The partial pressure of water vapor at the exit state is

$$P_{v2} = P_{\text{sat}@6.5^\circ\text{C}} = 0.9682 \text{ kPa} \quad (\text{Table A - 4})$$

The saturation pressure at the exit state is

$$P_{g2} = P_{\text{sat}@20^\circ\text{C}} = 2.339 \text{ kPa} \quad (\text{Table A - 4})$$

Then, the relative humidity at the exit state becomes

$$\phi_2 = \frac{P_{v2}}{P_{g2}} = \frac{0.9682}{2.339} = 0.4139$$

Now, the exit state is also fixed. The properties are obtained from EES to be

$$\begin{aligned}h_2 &= 35.41 \text{ kJ/kg dry air} \\ \omega_2 &= 0.006019 \text{ kg H}_2\text{O/kg dry air} \\ \nu_2 &= 0.8412 \text{ m}^3/\text{kg}\end{aligned}$$

The mass flow rate of dry air is

$$\dot{m}_a = \frac{\dot{V}_2}{\nu_2} = \frac{800 \text{ m}^3/\text{min}}{0.8412 \text{ m}^3/\text{kg}} = 951.1 \text{ kg/min}$$

The mass flow rate of condensate water is

$$\dot{m}_w = \dot{m}_a(\omega_1 - \omega_2) = (951.1 \text{ kg/min})(0.01056 - 0.006019) = 4.319 \text{ kg/min} = \mathbf{259 \text{ kg/h}}$$

The enthalpy of condensate water is

$$h_{w2} = h_{f@20^\circ\text{C}} = 83.91 \text{ kJ/kg} \quad (\text{Table A - 4})$$

An energy balance on the control volume gives

$$\begin{aligned}\dot{m}_a h_1 &= \dot{Q}_{\text{out}} + \dot{m}_a h_2 + \dot{m}_w h_{w2} \\ (951.1 \text{ kg/min})(57.20 \text{ kJ/kg}) &= \dot{Q}_{\text{out}} + (951.1 \text{ kg/min})(35.41 \text{ kJ/kg}) + (4.321 \text{ kg/min})(83.91 \text{ kJ/kg}) \\ \dot{Q}_{\text{out}} &= 20,360 \text{ kJ/min} = \mathbf{339 \text{ kW}}\end{aligned}$$

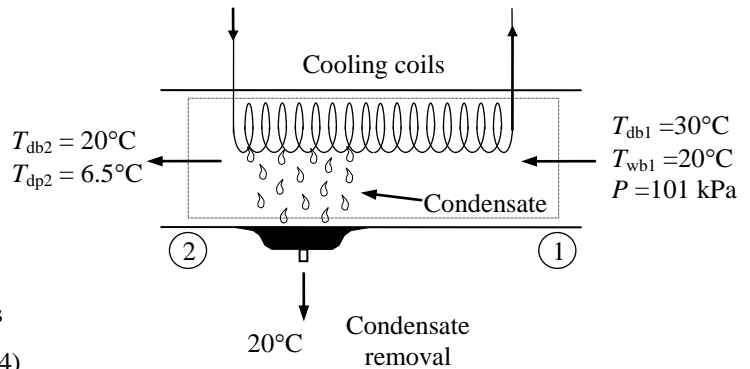

14-85 Atmospheric air enters the evaporator of an automobile air conditioner at a specified pressure, temperature, and relative humidity. The dew point and wet bulb temperatures at the inlet to the evaporator section, the required heat transfer rate from the atmospheric air to the evaporator fluid, and the rate of condensation of water vapor in the evaporator section are to be determined.

Assumptions 1 This is a steady-flow process and thus the mass flow rate of dry air remains constant during the entire process ($\dot{m}_{a1} = \dot{m}_{a2} = \dot{m}_a$). **2** Dry air and water vapor are ideal gases. **3** The kinetic and potential energy changes are negligible.

Analysis The inlet and exit states of the air are completely specified, and the total pressure is 1 atm. The properties of the air at the inlet and exit states may be determined from the psychrometric chart (Fig. A-31) or using EES psychrometric functions to be (we used EES)

$$T_{dp1} = 15.7^\circ\text{C}$$

$$T_{wb1} = 19.5^\circ\text{C}$$

$$h_1 = 55.60 \text{ kJ/kg dry air}$$

$$\omega_1 = 0.01115 \text{ kg H}_2\text{O/kg dry air}$$

$$\nu_1 = 0.8655 \text{ m}^3 / \text{kg dry air}$$

$$h_2 = 27.35 \text{ kJ/kg dry air}$$

$$\omega_2 = 0.00686 \text{ kg H}_2\text{O/kg dry air}$$

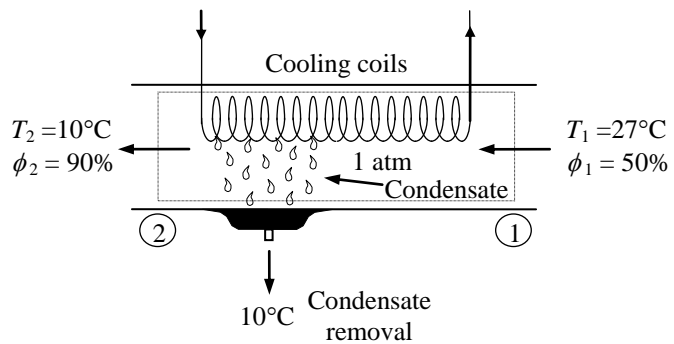

The mass flow rate of dry air is

$$\dot{m}_a = \frac{\dot{V}_1}{\nu_1} = \frac{V_{car} \text{ ACH}}{\nu_1} = \frac{(2 \text{ m}^3/\text{change})(5 \text{ changes/min})}{0.8655 \text{ m}^3} = 11.55 \text{ kg/min}$$

The mass flow rates of vapor at the inlet and exit are

$$\dot{m}_{v1} = \omega_1 \dot{m}_a = (0.01115)(11.55 \text{ kg/min}) = 0.1288 \text{ kg/min}$$

$$\dot{m}_{v2} = \omega_2 \dot{m}_a = (0.00686)(11.55 \text{ kg/min}) = 0.07926 \text{ kg/min}$$

An energy balance on the control volume gives

$$\dot{m}_a h_1 = \dot{Q}_{out} + \dot{m}_a h_2 + \dot{m}_w h_{w2}$$

where the the enthalpy of condensate water is

$$h_{w2} = h_{f@10^\circ\text{C}} = 42.02 \text{ kJ/kg} \quad (\text{Table A-4})$$

and the rate of condensation of water vapor is

$$\dot{m}_w = \dot{m}_{v1} - \dot{m}_{v2} = 0.1288 - 0.07926 = \mathbf{0.0495 \text{ kg/min}}$$

Substituting,

$$\begin{aligned} \dot{m}_a h_1 &= \dot{Q}_{out} + \dot{m}_a h_2 + \dot{m}_w h_{w2} \\ (11.55 \text{ kg/min})(55.60 \text{ kJ/kg}) &= \dot{Q}_{out} + (11.55 \text{ kg/min})(27.35 \text{ kJ/kg}) + (0.0495 \text{ kg/min})(42.02 \text{ kJ/kg}) \\ \dot{Q}_{out} &= 324.4 \text{ kJ/min} = \mathbf{5.41 \text{ kW}} \end{aligned}$$

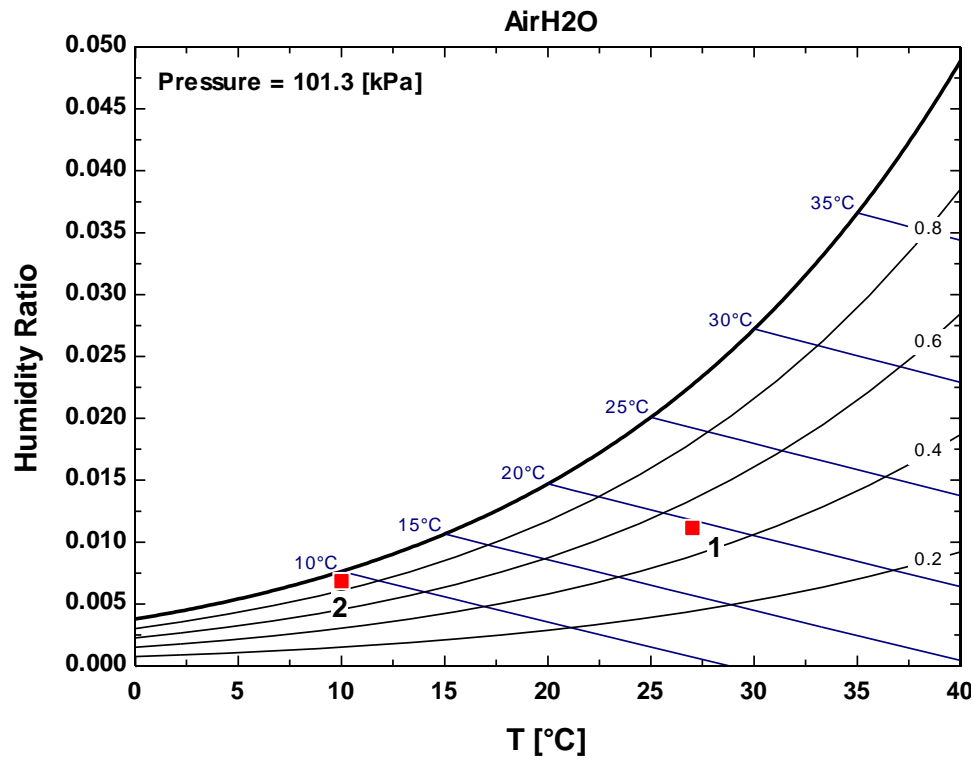

Discussion We could not show the process line between the states 1 and 2 because we do not know the process path.

14-86 Air is cooled and dehumidified at constant pressure. The cooling required is provided by a simple ideal vapor-compression refrigeration system using refrigerant-134a as the working fluid. The exergy destruction in the total system per 1000 m³ of dry air is to be determined.

Assumptions 1 This is a steady-flow process and thus the mass flow rate of dry air remains constant during the entire process ($\dot{m}_{a1} = \dot{m}_{a2} = \dot{m}_a$). **2** Dry air and water vapor are ideal gases. **3** The kinetic and potential energy changes are negligible.

Properties The inlet and the exit states of the air are completely specified, and the total pressure is 1 atm. The properties of the air at various states are determined from the psychrometric chart (Figure A-31) to be

$$\begin{aligned} h_1 &= 106.8 \text{ kJ/kg dry air} \\ \omega_1 &= 0.0292 \text{ kg H}_2\text{O/kg dry air} \\ \nu_1 &= 0.905 \text{ m}^3/\text{kg dry air} \end{aligned}$$

and

$$\begin{aligned} h_2 &= 52.7 \text{ kJ/kg dry air} \\ \omega_2 &= 0.0112 \text{ kg H}_2\text{O/kg dry air} \end{aligned}$$

We assume that the condensate leaves this system at the average temperature of the air inlet and exit. Then, from Table A-4,

$$h_w \cong h_f @ 28^\circ\text{C} = 117.4 \text{ kJ/kg}$$

Analysis The amount of moisture in the air decreases due to dehumidification ($\omega_2 < \omega_1$). The mass of air is

$$m_a = \frac{\nu_1}{\nu_1} = \frac{1000 \text{ m}^3}{0.905 \text{ m}^3/\text{kg dry air}} = 1105 \text{ kg}$$

Applying the water mass balance and energy balance equations to the combined cooling and dehumidification section,

Water Mass Balance:

$$\begin{aligned} \sum \dot{m}_{w,i} &= \sum \dot{m}_{w,e} \longrightarrow \dot{m}_{a1}\omega_1 = \dot{m}_{a2}\omega_2 + \dot{m}_w \\ m_w &= m_a(\omega_1 - \omega_2) = (1105 \text{ kg})(0.0292 - 0.0112) = 19.89 \text{ kg} \end{aligned}$$

Energy Balance:

$$\begin{aligned} \dot{E}_{in} - \dot{E}_{out} &= \Delta \dot{E}_{system} \overset{\phi^0(\text{steady})}{=} 0 \\ \dot{E}_{in} &= \dot{E}_{out} \\ \sum \dot{m}_i h_i &= \dot{Q}_{out} + \sum \dot{m}_e h_e \\ \dot{Q}_{out} &= \dot{m}_{a1}h_1 - (\dot{m}_{a2}h_2 + \dot{m}_w h_w) = \dot{m}_a(h_1 - h_2) - \dot{m}_w h_w \\ Q_{out} &= m_a(h_1 - h_2) - m_w h_w \\ Q_{out} &= (1105 \text{ kg})(106.8 - 52.7) \text{ kJ/kg} - (19.89 \text{ kg})(117.4 \text{ kJ/kg}) = 57,450 \text{ kJ} \end{aligned}$$

We obtain the properties for the vapor-compression refrigeration cycle as follows (Tables A-11, through A-13):

$$\begin{aligned} \left. \begin{aligned} T_1 &= 4^\circ\text{C} \\ \text{sat. vapor} \end{aligned} \right\} \begin{aligned} h_1 &= h_g @ 4^\circ\text{C} = 252.77 \text{ kJ/kg} \\ s_1 &= s_g @ 4^\circ\text{C} = 0.92927 \text{ kJ/kg} \cdot \text{K} \end{aligned} \\ \left. \begin{aligned} P_2 &= P_{\text{sat}} @ 39.4^\circ\text{C} = 1 \text{ MPa} \\ s_2 &= s_1 \end{aligned} \right\} \begin{aligned} h_2 &= 275.29 \text{ kJ/kg} \end{aligned} \\ \left. \begin{aligned} P_3 &= 1 \text{ MPa} \\ \text{sat. liquid} \end{aligned} \right\} \begin{aligned} h_3 &= h_f @ 1 \text{ MPa} = 107.32 \text{ kJ/kg} \\ s_3 &= s_f @ 1 \text{ MPa} = 0.39189 \text{ kJ/kg} \cdot \text{K} \end{aligned} \\ h_4 &\cong h_3 = 107.32 \text{ kJ/kg} \quad (\text{throttling}) \\ \left. \begin{aligned} T_4 &= 4^\circ\text{C} \\ h_4 &= 107.32 \text{ kJ/kg} \end{aligned} \right\} \begin{aligned} x_4 &= 0.2561 \\ s_4 &= 0.4045 \text{ kJ/kg} \cdot \text{K} \end{aligned} \end{aligned}$$

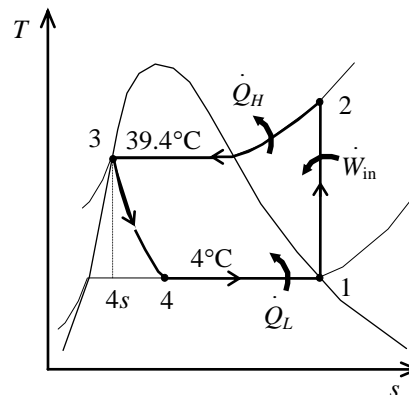
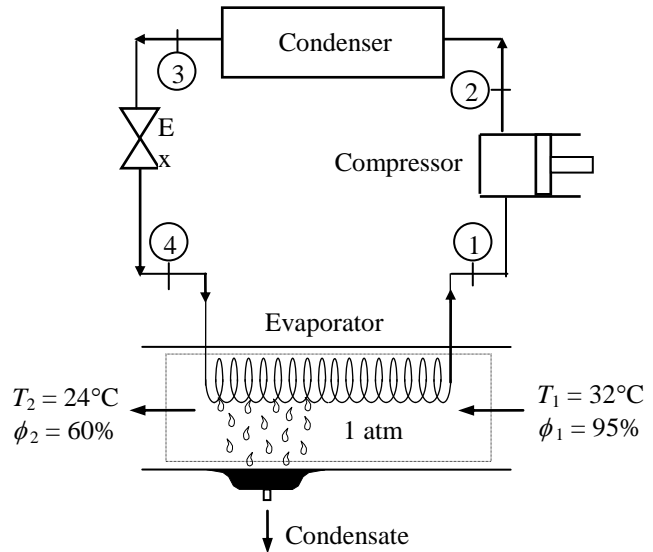

The mass flow rate of refrigerant-134a is

$$m_R = \frac{Q_L}{h_1 - h_4} = \frac{57,450 \text{ kJ}}{(252.77 - 107.32) \text{ kJ/kg}} = 395.0 \text{ kg}$$

The amount of heat rejected from the condenser is

$$Q_H = m_R(h_2 - h_3) = (395.0 \text{ kg})(275.29 - 107.32) \text{ kJ/kg} = 66,350 \text{ kJ}$$

Next, we calculate the exergy destruction in the components of the refrigeration cycle:

$$X_{\text{destroyed},12} = m_R T_0 (s_2 - s_1) = 0 \quad (\text{since the process is isentropic})$$

$$\begin{aligned} X_{\text{destroyed},23} &= T_0 \left(m_R (s_3 - s_2) + \frac{Q_H}{T_H} \right) \\ &= (305 \text{ K}) \left((395 \text{ kg})(0.39189 - 0.92927) \text{ kJ/kg} \cdot \text{K} + \frac{66,350 \text{ kJ}}{305 \text{ K}} \right) = 1609 \text{ kJ} \end{aligned}$$

$$X_{\text{destroyed},34} = m_R T_0 (s_4 - s_3) = (395 \text{ kg})(305 \text{ K})(0.4045 - 0.39189) \text{ kJ/kg} \cdot \text{K} = 1519 \text{ kJ}$$

The entropies of water vapor in the air stream are

$$s_{g1} = s_g @ 32^\circ\text{C} = 8.4114 \text{ kJ/kg} \cdot \text{K}$$

$$s_{g2} = s_g @ 24^\circ\text{C} = 8.5782 \text{ kJ/kg} \cdot \text{K}$$

The entropy change of water vapor in the air stream is

$$\Delta S_{\text{vapor}} = m_a (\omega_2 s_{g2} - \omega_1 s_{g1}) = (1105)(0.0112 \times 8.5782 - 0.0292 \times 8.4114) = -165.2 \text{ kJ/K}$$

The entropy of water leaving the cooling section is

$$S_w = m_w s_f @ 28^\circ\text{C} = (19.89 \text{ kg})(0.4091 \text{ kJ/kg} \cdot \text{K}) = 8.14 \text{ kJ/K}$$

The partial pressures of water vapor and dry air for air streams are

$$P_{v1} = \phi_1 P_{g1} = \phi_1 P_{\text{sat}} @ 32^\circ\text{C} = (0.95)(4.760 \text{ kPa}) = 4.522 \text{ kPa}$$

$$P_{a1} = P_1 - P_{v1} = 101.325 - 4.522 = 96.80 \text{ kPa}$$

$$P_{v2} = \phi_2 P_{g2} = \phi_2 P_{\text{sat}} @ 24^\circ\text{C} = (0.60)(2.986 \text{ kPa}) = 1.792 \text{ kPa}$$

$$P_{a2} = P_2 - P_{v2} = 101.325 - 1.792 = 99.53 \text{ kPa}$$

The entropy change of dry air is

$$\begin{aligned} \Delta S_a &= m_a (s_2 - s_1) = m_a \left(c_p \ln \frac{T_2}{T_1} - R \ln \frac{P_{a2}}{P_{a1}} \right) \\ &= (1105) \left[(1.005) \ln \frac{297}{305} - (0.287) \ln \frac{99.53}{96.80} \right] = -38.34 \text{ kJ/kg dry air} \end{aligned}$$

The entropy change of R-134a in the evaporator is

$$\Delta S_{R,41} = m_R (s_1 - s_4) = (395 \text{ kg})(0.92927 - 0.4045) = 207.3 \text{ kJ/K}$$

An entropy balance on the evaporator gives

$$S_{\text{gen, evaporator}} = \Delta S_{R,41} + \Delta S_{\text{vapor}} + \Delta S_a + S_w = 207.3 + (-165.2) + (-38.34) + 8.14 = 11.90 \text{ kJ/K}$$

Then, the exergy destruction in the evaporator is

$$X_{\text{dest}} = T_0 S_{\text{gen, evaporator}} = (305 \text{ K})(11.90 \text{ kJ/K}) = 3630 \text{ kJ}$$

Finally the total exergy destruction is

$$\begin{aligned} X_{\text{dest, total}} &= X_{\text{dest, compressor}} + X_{\text{dest, condenser}} + X_{\text{dest, throttle}} + X_{\text{dest, evaporator}} \\ &= 0 + 1609 + 1519 + 3630 \\ &= \mathbf{6758 \text{ kJ}} \end{aligned}$$

The greatest exergy destruction occurs in the evaporator. Note that heat is absorbed from humid air and rejected to the ambient air at 32°C (305 K), which is also taken as the dead state temperature.

14-87 Air is cooled, dehumidified and heated at constant pressure. The system hardware and the psychrometric diagram are to be sketched, the dew point temperatures, and the heat transfer are to be determined.

Assumptions 1 This is a steady-flow process and thus the mass flow rate of dry air remains constant during the entire process ($\dot{m}_{a1} = \dot{m}_{a2} = \dot{m}_a$). **2** Dry air and water vapor are ideal gases. **3** The kinetic and potential energy changes are negligible.

Analysis (a) The schematic of the cooling and dehumidification process and the the process on the psychrometric chart are given below. The psychrometric chart is obtained from the Property Plot feature of EES.

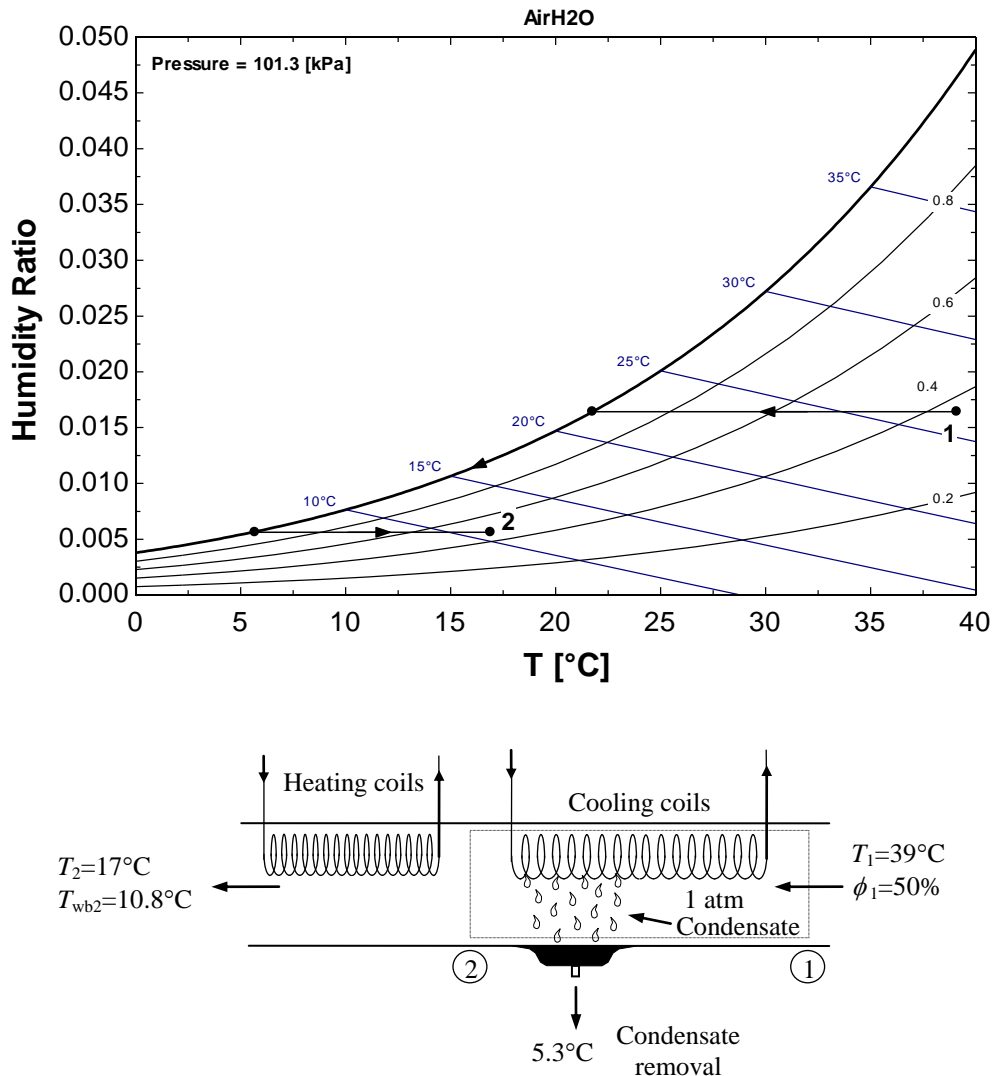

(b) The inlet and the exit states of the air are completely specified, and the total pressure is 1 atm. The properties of the air at the inlet and exit states are determined from the psychrometric chart (Figure A-31 or EES) to be

$$T_{dp1} = \mathbf{26.7^\circ\text{C}}$$

$$h_1 = 96.5 \text{ kJ/kg dry air}$$

$$\omega_1 = 0.0222 \text{ kg H}_2\text{O/kg dry air}$$

and

$$T_{dp2} = \mathbf{5.3^\circ C}$$

$$\phi_2 = 46\%$$

$$h_2 = 31.1 \text{ kJ/kg dry air}$$

$$\omega_2 = 0.00551 \text{ kg H}_2\text{O/kg dry air}$$

Also,

$$h_w \cong h_f @ 5.3^\circ C = 22.2 \text{ kJ/kg} \quad (\text{Table A-4})$$

The enthalpy of water is evaluated at 5.3°C, which is the temperature of air at the end of the dehumidification process.

(c) Applying the water mass balance and energy balance equations to the combined cooling and dehumidification section,

Water Mass Balance:

$$\sum \dot{m}_{w,i} = \sum \dot{m}_{w,e} \longrightarrow \dot{m}_{a1}\omega_1 = \dot{m}_{a2}\omega_2 + \dot{m}_w$$

$$\dot{m}_w = \dot{m}_a(\omega_1 - \omega_2)$$

Energy Balance:

$$\dot{E}_{in} - \dot{E}_{out} = \Delta \dot{E}_{system} \stackrel{\phi^0(\text{steady})}{=} 0$$

$$\dot{E}_{in} = \dot{E}_{out}$$

$$\sum \dot{m}_i h_i = \dot{Q}_{out} + \sum \dot{m}_e h_e$$

$$\dot{Q}_{out} = \dot{m}_{a1}h_1 - (\dot{m}_{a2}h_2 + \dot{m}_w h_w)$$

$$= \dot{m}_a(h_1 - h_2) - \dot{m}_w h_w$$

$$= \dot{m}_a(h_1 - h_2) - \dot{m}_a(\omega_1 - \omega_2)h_w$$

Substituting,

$$\begin{aligned} q_{out} &= (h_1 - h_2) - (\omega_1 - \omega_2)h_w \\ &= (96.5 - 31.1) \text{ kJ/kg} - (0.0222 - 0.00551)(22.2 \text{ kJ/kg}) \\ &= \mathbf{65.1 \text{ kJ/kg}} \end{aligned}$$

Evaporative Cooling

14-88C Evaporative cooling is the cooling achieved when water evaporates in dry air. It will not work on humid climates.

14-89C During evaporation from a water body to air, the latent heat of vaporization will be equal to *convection* heat transfer from the air when *conduction* from the lower parts of the water body to the surface is negligible, and temperature of the surrounding surfaces is at about the temperature of the water surface so that the *radiation* heat transfer is negligible.

14-90C In steady operation, the mass transfer process does not have to involve heat transfer. However, a mass transfer process that involves phase change (evaporation, sublimation, condensation, melting etc.) must involve heat transfer. For example, the evaporation of water from a lake into air (mass transfer) requires the transfer of latent heat of water at a specified temperature to the liquid water at the surface (heat transfer).

14-91 Air is cooled by an evaporative cooler. The exit temperature of the air is to be determined.

Analysis The enthalpy of air at the inlet is determined from

$$\begin{aligned}
 P_{v1} &= \phi_1 P_{g1} = \phi_1 P_{\text{sat}@40^\circ\text{C}} = (0.25)(7.3851 \text{ kPa}) = 1.846 \text{ kPa} \\
 \omega_1 &= \frac{0.622 P_{v1}}{P_1 - P_{v1}} = \frac{0.622(1.846 \text{ kPa})}{(95 - 1.846) \text{ kPa}} = 0.01233 \text{ kg H}_2\text{O/kg dry air} \\
 h_1 &= c_p T_1 + \omega_1 h_{g1} \\
 &= (1.005 \text{ kJ/kg}\cdot^\circ\text{C})(40^\circ\text{C}) + (0.01233)(2573.5 \text{ kJ/kg}) \\
 &= 71.93 \text{ kJ/kg dry air}
 \end{aligned}$$

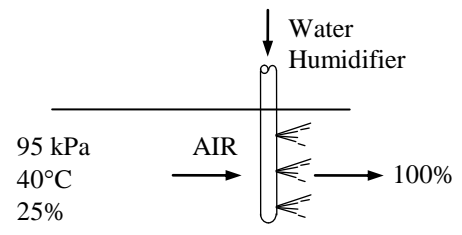

Assuming the liquid water is supplied at a temperature not much different than the exit temperature of the air stream, the evaporative cooling process follows a line of constant wet-bulb temperature, which is almost parallel to the constant enthalpy lines. That is,

$$h_2 \cong h_1 = 71.93 \text{ kJ/kg dry air}$$

Also,

$$\omega_2 = \frac{0.622 P_{v2}}{P_2 - P_{v2}} = \frac{0.622 P_{g2}}{95 - P_{g2}}$$

since air leaves the evaporative cooler saturated. Substituting this into the definition of enthalpy, we obtain

$$\begin{aligned}
 h_2 &= c_p T_2 + \omega_2 h_{g2} \cong c_p T_2 + \omega_2 (2500.9 + 1.82 T_2) \\
 71.93 \text{ kJ/kg} &= (1.005 \text{ kJ/kg}\cdot^\circ\text{C})T_2 + \frac{0.622 P_{g2}}{95 - P_{g2}} (2500.9 + 1.82 T_2) \text{ kJ/kg}
 \end{aligned}$$

By trial and error, the exit temperature is determined to be

$$T_2 = \mathbf{23.1^\circ\text{C}}.$$

14-92E Air is cooled by an evaporative cooler. The exit temperature of the air is to be determined.

Analysis The enthalpy of air at the inlet is determined from

$$P_{v1} = \phi_1 P_{g1} = \phi_1 P_{\text{sat}@93^\circ\text{F}} = (0.30)(0.7676 \text{ psia}) = 0.230 \text{ psia}$$

$$\omega_1 = \frac{0.622 P_{v1}}{P_1 - P_{v1}} = \frac{0.622(0.230 \text{ psia})}{(14.5 - 0.230) \text{ psia}}$$

$$= 0.01004 \text{ lbm H}_2\text{O/lbm dry air}$$

$$h_1 = c_p T_1 + \omega_1 h_{g1}$$

$$= (0.24 \text{ Btu/lbm}\cdot^\circ\text{F})(93^\circ\text{F}) + (0.01004)(1101.7 \text{ Btu/lbm})$$

$$= 33.38 \text{ Btu/lbmdry air}$$

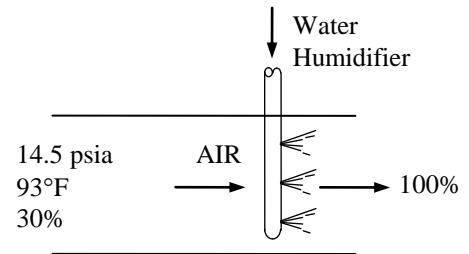

Assuming the liquid water is supplied at a temperature not much different than the exit temperature of the air stream, the evaporative cooling process follows a line of constant wet-bulb temperature, which is almost parallel to the constant enthalpy lines. That is,

$$h_2 \cong h_1 = 33.38 \text{ Btu/lbmdry air}$$

Also,

$$\omega_2 = \frac{0.622 P_{v2}}{P_2 - P_{v2}} = \frac{0.622 P_{g2}}{14.5 - P_{g2}}$$

since air leaves the evaporative cooler saturated. Substituting this into the definition of enthalpy, we obtain

$$h_2 = c_p T_2 + \omega_2 h_{g2} \cong c_p T_2 + \omega_2 (1060.9 + 0.435 T_2)$$

$$33.38 \text{ Btu/lbm} = (0.24 \text{ Btu/lbm}\cdot^\circ\text{F})T_2 + \frac{0.622 P_{g2}}{14.5 - P_{g2}} (1060.9 + 0.435 T_2)$$

By trial and error, the exit temperature is determined to be

$$T_2 = \mathbf{69.0^\circ\text{F}}$$

14-93 Air is cooled by an evaporative cooler. The exit temperature of the air and the required rate of water supply are to be determined.

Analysis (a) From the psychrometric chart (Fig. A-31 or EES) at 40°C and 20% relative humidity we read

$$T_{wb1} = 22.04^\circ\text{C}$$

$$\omega_1 = 0.009199 \text{ kg H}_2\text{O/kg dry air}$$

$$\nu_1 = 0.9002 \text{ m}^3/\text{kg dry air}$$

Assuming the liquid water is supplied at a temperature not much different than the exit temperature of the air stream, the evaporative cooling process follows a line of constant wet-bulb temperature. That is,

$$T_{wb2} \cong T_{wb1} = 22.04^\circ\text{C}$$

At this wet-bulb temperature and 90% relative humidity we read

$$T_2 = \mathbf{23.3^\circ\text{C}}$$

$$\omega_2 = 0.01619 \text{ kg H}_2\text{O/kg dry air}$$

Thus air will be cooled to 23.3°C in this evaporative cooler.

(b) The mass flow rate of dry air is

$$\dot{m}_a = \frac{\dot{V}_1}{\nu_1} = \frac{7 \text{ m}^3 / \text{min}}{0.9002 \text{ m}^3 / \text{kg dry air}} = 7.776 \text{ kg/min}$$

Then the required rate of water supply to the evaporative cooler is determined from

$$\begin{aligned} \dot{m}_{\text{supply}} &= \dot{m}_{w2} - \dot{m}_{w1} \\ &= \dot{m}_a(\omega_2 - \omega_1) \\ &= (7.776 \text{ kg/min})(0.01619 - 0.009199) \\ &= \mathbf{0.0543 \text{ kg/min}} \end{aligned}$$

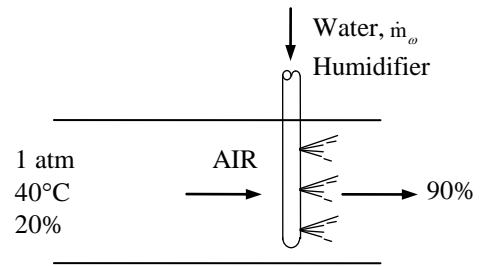

14-94 Air is cooled by an evaporative cooler. The final relative humidity and the amount of water added are to be determined.

Analysis (a) From the psychrometric chart (Fig. A-31) at 32°C and 30% relative humidity we read

$$T_{wb1} = 19.4^\circ\text{C}$$

$$\omega_1 = 0.0089 \text{ kg H}_2\text{O/kg dry air}$$

$$\nu_1 = 0.877 \text{ m}^3/\text{kg dry air}$$

Assuming the liquid water is supplied at a temperature not much different than the exit temperature of the air stream, the evaporative cooling process follows a line of constant wet-bulb temperature. That is,

$$T_{wb2} \cong T_{wb1} = 19.4^\circ\text{C}$$

At this wet-bulb temperature and 22°C temperature we read

$$\phi_2 = 79\%$$

$$\omega_2 = 0.0130 \text{ kg H}_2\text{O/kg dry air}$$

(b) The mass flow rate of dry air is

$$\dot{m}_a = \frac{\dot{V}_1}{\nu_1} = \frac{5 \text{ m}^3/\text{min}}{0.877 \text{ m}^3/\text{kg dry air}} = 5.70 \text{ kg/min}$$

Then the required rate of water supply to the evaporative cooler is determined from

$$\dot{m}_{\text{supply}} = \dot{m}_{w2} - \dot{m}_{w1} = \dot{m}_a(\omega_2 - \omega_1) = (5.70 \text{ kg/min})(0.0130 - 0.0089) = \mathbf{0.0234 \text{ kg/min}}$$

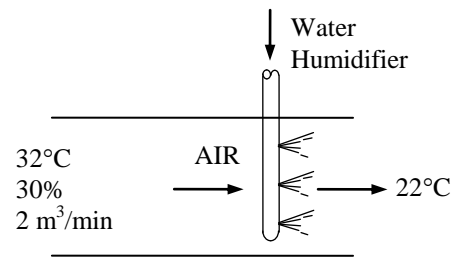

14-95 Air is first heated in a heating section and then passed through an evaporative cooler. The exit relative humidity and the amount of water added are to be determined.

Analysis (a) From the psychrometric chart (Fig. A-31 or EES) at 20°C and 50% relative humidity we read

$$\omega_1 = 0.00726 \text{ kg H}_2\text{O/kg dry air}$$

The specific humidity ω remains constant during the heating process. Therefore, $\omega_2 = \omega_1 = 0.00726 \text{ kg H}_2\text{O/kg dry air}$.

At this ω value and 35°C we read $T_{wb2} = 19.1^\circ\text{C}$.

Assuming the liquid water is supplied at a temperature not much different than the exit temperature of the air stream, the evaporative cooling process follows a line of constant wet-bulb temperature. That is, $T_{wb3} \cong T_{wb2} = 19.1^\circ\text{C}$. At this T_{wb} value and 25°C we read

$$\phi_3 = 57.5\%$$

$$\omega_3 = 0.0114 \text{ kg H}_2\text{O/kg dry air}$$

(b) The amount of water added to the air per unit mass of air is

$$\Delta\omega_{23} = \omega_3 - \omega_2 = 0.0114 - 0.00726 = \mathbf{0.00413 \text{ kg H}_2\text{O/kg dry air}}$$

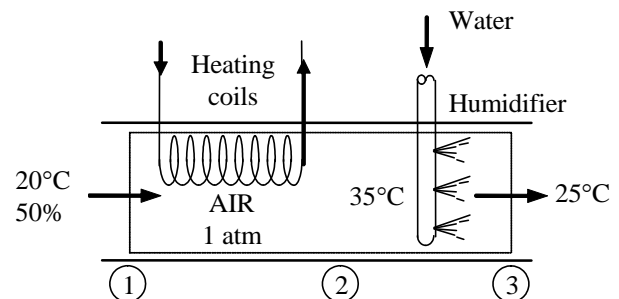

Adiabatic Mixing of Airstreams

14-96C This will occur when the straight line connecting the states of the two streams on the psychrometric chart crosses the saturation line.

14-97C Yes.

14-98E Two airstreams are mixed steadily. The temperature, the specific humidity, and the relative humidity of the mixture are to be determined.

Assumptions **1** Steady operating conditions exist **2** Dry air and water vapor are ideal gases. **3** The kinetic and potential energy changes are negligible. **4** The mixing section is adiabatic.

Properties The properties of each inlet stream are determined from the psychrometric chart (Fig. A-31E) to be

$$h_1 = 19.9 \text{ Btu/lbm dry air}$$

$$\omega_1 = 0.0039 \text{ lbm H}_2\text{O/lbm dry air}$$

$$\nu_1 = 13.30 \text{ ft}^3/\text{lbm dry air}$$

and

$$h_2 = 41.1 \text{ Btu/lbm dry air}$$

$$\omega_2 = 0.0200 \text{ lbm H}_2\text{O/lbm dry air}$$

$$\nu_2 = 14.04 \text{ ft}^3/\text{lbm dry air}$$

Analysis The mass flow rate of dry air in each stream is

$$\dot{m}_{a1} = \frac{\dot{V}_1}{\nu_1} = \frac{900 \text{ ft}^3/\text{min}}{13.30 \text{ ft}^3/\text{lbm dry air}} = 67.7 \text{ lbm/min}$$

$$\dot{m}_{a2} = \frac{\dot{V}_2}{\nu_2} = \frac{300 \text{ ft}^3/\text{min}}{14.04 \text{ ft}^3/\text{lbm dry air}} = 21.4 \text{ lbm/min}$$

The specific humidity and the enthalpy of the mixture can be determined from Eqs. 14-24, which are obtained by combining the conservation of mass and energy equations for the adiabatic mixing of two streams:

$$\frac{\dot{m}_{a1}}{\dot{m}_{a2}} = \frac{\omega_2 - \omega_3}{\omega_3 - \omega_1} = \frac{h_2 - h_3}{h_3 - h_1}$$

$$\frac{67.7}{21.4} = \frac{0.0200 - \omega_3}{\omega_3 - 0.0039} = \frac{41.1 - h_3}{h_3 - 19.9}$$

which yields,

$$(a) \quad \omega_3 = \mathbf{0.0078 \text{ lbm H}_2\text{O/lbm dry air}}$$

$$h_3 = 25.0 \text{ Btu/lbm dry air}$$

These two properties fix the state of the mixture. Other properties of the mixture are determined from the psychrometric chart:

$$(b) \quad T_3 = \mathbf{68.7^\circ\text{F}}$$

$$(c) \quad \phi_3 = \mathbf{52.1\%}$$

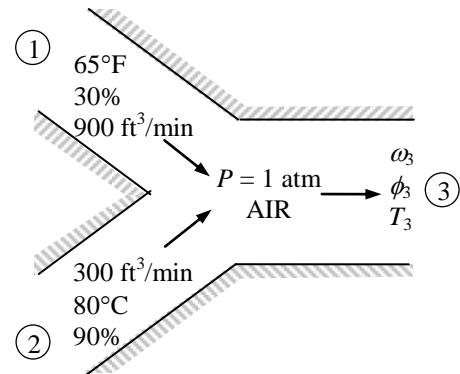



14-99E Problem 14-98E is reconsidered. A general solution of the problem in which the input variables may be supplied and parametric studies performed is to be developed and the process is to be shown in the psychrometric chart for each set of input variables.

Analysis The problem is solved using EES, and the solution is given below.

"Input Data by Diagram Window:"

```
{P=14.696 [psia]
Tdb[1]=65 [F]
Rh[1]=0.30
V_dot[1]=900 [ft^3/min]
Tdb[2]=80 [F]
Rh[2]=0.90
V_dot[2]=300 [ft^3/min]}
P[1]=P
P[2]=P[1]
P[3]=P[1]
```

"Energy balance for the steady-flow mixing process:"

"We neglect the PE of the flow. Since we don't know the cross sectional area of the flow streams, we also neglect the KE of the flow."

```
E_dot_in - E_dot_out = DELTAE_dot_sys
DELTAE_dot_sys = 0 [kW]
E_dot_in = m_dot[1]*h[1]+m_dot[2]*h[2]
E_dot_out = m_dot[3]*h[3]
```

"Conservation of mass of dry air during mixing:"

```
m_dot[1]+m_dot[2] = m_dot[3]
```

"Conservation of mass of water vapor during mixing:"

```
m_dot[1]*w[1]+m_dot[2]*w[2] = m_dot[3]*w[3]
```

```
m_dot[1]=V_dot[1]/v[1]*convert(1/min,1/s)
m_dot[2]=V_dot[2]/v[2]*convert(1/min,1/s)
h[1]=ENTHALPY(AirH2O,T=Tdb[1],P=P[1],R=Rh[1])
v[1]=VOLUME(AirH2O,T=Tdb[1],P=P[1],R=Rh[1])
w[1]=HUMRAT(AirH2O,T=Tdb[1],P=P[1],R=Rh[1])
```

```
h[2]=ENTHALPY(AirH2O,T=Tdb[2],P=P[2],R=Rh[2])
v[2]=VOLUME(AirH2O,T=Tdb[2],P=P[2],R=Rh[2])
w[2]=HUMRAT(AirH2O,T=Tdb[2],P=P[2],R=Rh[2])
```

```
Tdb[3]=TEMPERATURE(AirH2O,h=h[3],P=P[3],w=w[3])
Rh[3]=RELHUM(AirH2O,T=Tdb[3],P=P[3],w=w[3])
v[3]=VOLUME(AirH2O,T=Tdb[3],P=P[3],w=w[3])
m_dot[3]=V_dot[3]/v[3]*convert(1/min,1/s)
```

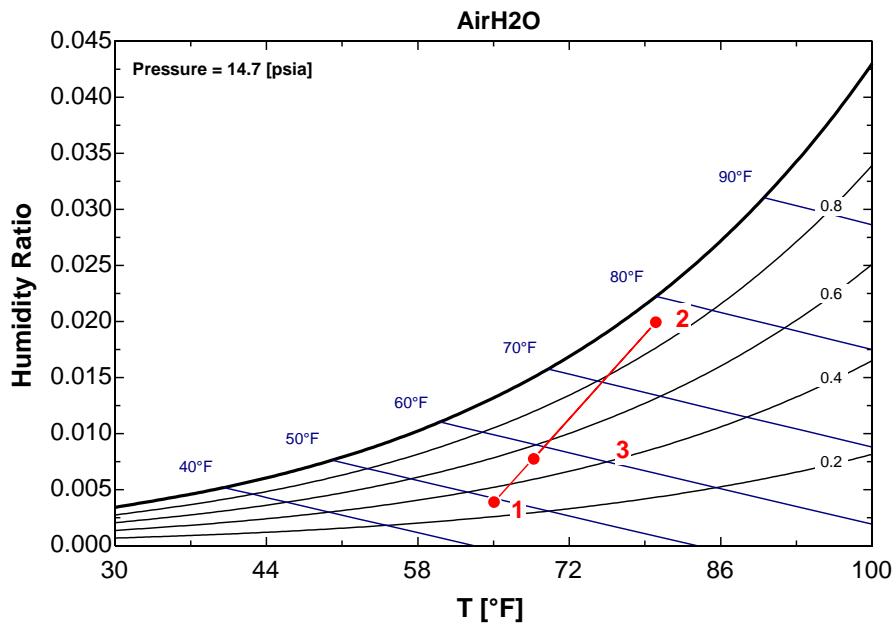

SOLUTION

DELTAE_dot_sys=0	E_dot_in=37.04 [kW]
E_dot_out=37.04 [kW]	h[1]=19.88 [Btu/lb_m]
h[2]=41.09 [Btu/lb_m]	h[3]=24.97 [Btu/lb_m]
m_dot[1]=1.127 [kga/s]	m_dot[2]=0.3561 [kga/s]
m_dot[3]=1.483 [kga/s]	P=14.7 [psia]
P[1]=14.7 [psia]	P[2]=14.7 [psia]
P[3]=14.7 [psia]	Rh[1]=0.3
Rh[2]=0.9	Rh[3]=0.5214
Tdb[1]=65 [F]	Tdb[2]=80 [F]
Tdb[3]=68.68 [F]	v[1]=13.31 [ft^3/lb_ma]
v[2]=14.04 [ft^3/lb_ma]	v[3]=13.49 [ft^3/lb_ma]
V_dot[1]=900 [ft^3/min]	V_dot[2]=300 [ft^3/min]
V_dot[3]=1200 [ft^3/min]	w[1]=0.003907 [lb_mv/lb_ma]
w[2]=0.01995 [lb_mv/lb_ma]	w[3]=0.007759 [lb_mv/lb_ma]

14-100 Two airstreams are mixed steadily. The specific humidity, the relative humidity, the dry-bulb temperature, and the volume flow rate of the mixture are to be determined.

Assumptions 1 Steady operating conditions exist 2 Dry air and water vapor are ideal gases. 3 The kinetic and potential energy changes are negligible. 4 The mixing section is adiabatic.

Properties Properties of each inlet stream are determined from the psychrometric chart (Fig. A-31 or EES) to be

$$\begin{aligned}h_1 &= 62.28 \text{ kJ/kg dry air} \\ \omega_1 &= 0.01054 \text{ kg H}_2\text{O/kg dry air} \\ \nu_1 &= 0.8877 \text{ m}^3/\text{kg dry air}\end{aligned}$$

and

$$\begin{aligned}h_2 &= 31.88 \text{ kJ/kg dry air} \\ \omega_2 &= 0.007847 \text{ kg H}_2\text{O/kg dry air} \\ \nu_2 &= 0.8180 \text{ m}^3/\text{kg dry air}\end{aligned}$$

Analysis The mass flow rate of dry air in each stream is

$$\begin{aligned}\dot{m}_{a1} &= \frac{\dot{V}_1}{\nu_1} = \frac{15 \text{ m}^3/\text{min}}{0.8877 \text{ m}^3/\text{kg dry air}} = 16.90 \text{ kg/min} \\ \dot{m}_{a2} &= \frac{\dot{V}_2}{\nu_2} = \frac{25 \text{ m}^3/\text{min}}{0.8180 \text{ m}^3/\text{kg dry air}} = 30.56 \text{ kg/min}\end{aligned}$$

From the conservation of mass,

$$\dot{m}_{a3} = \dot{m}_{a1} + \dot{m}_{a2} = 16.90 + 30.56 = 47.46 \text{ kg/min}$$

The specific humidity and the enthalpy of the mixture can be determined from Eqs. 14-24, which are obtained by combining the conservation of mass and energy equations for the adiabatic mixing of two streams:

$$\begin{aligned}\frac{\dot{m}_{a1}}{\dot{m}_{a2}} &= \frac{\omega_2 - \omega_3}{\omega_3 - \omega_1} = \frac{h_2 - h_3}{h_3 - h_1} \\ \frac{16.90}{30.56} &= \frac{0.007847 - \omega_3}{\omega_3 - 0.01054} = \frac{31.88 - h_3}{h_3 - 62.28}\end{aligned}$$

which yields

$$\begin{aligned}h_3 &= 42.70 \text{ kJ/kg dry air} \\ \omega_3 &= \mathbf{0.0088 \text{ kg H}_2\text{O/kg dry air}}\end{aligned}$$

These two properties fix the state of the mixture. Other properties of the mixture are determined from the psychrometric chart:

$$\begin{aligned}T_3 &= \mathbf{20.2^\circ\text{C}} \\ \phi_3 &= \mathbf{59.7\%} \\ \nu_3 &= 0.8428 \text{ m}^3/\text{kg dry air}\end{aligned}$$

Finally, the volume flow rate of the mixture is determined from

$$\dot{V}_3 = \dot{m}_{a3} \nu_3 = (47.46 \text{ kg/min})(0.8428 \text{ m}^3/\text{kg dry air}) = \mathbf{40.0 \text{ m}^3/\text{min}}$$

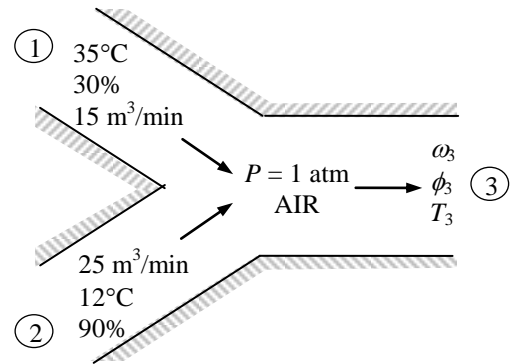

14-101 Two airstreams are mixed steadily. The specific humidity, the relative humidity, the dry-bulb temperature, and the volume flow rate of the mixture are to be determined.

Assumptions 1 Steady operating conditions exist 2 Dry air and water vapor are ideal gases. 3 The kinetic and potential energy changes are negligible. 4 The mixing section is adiabatic.

Analysis The properties of each inlet stream are determined to be

$$P_{v1} = \phi_1 P_{g1} = \phi_1 P_{\text{sat}@35^\circ\text{C}} = (0.30)(5.629 \text{ kPa}) = 1.689 \text{ kPa}$$

$$P_{a1} = P_1 - P_{v1} = 90 - 1.689 = 88.31 \text{ kPa}$$

$$\nu_1 = \frac{R_a T_1}{P_{a1}} = \frac{(0.287 \text{ kPa} \cdot \text{m}^3 / \text{kg} \cdot \text{K})(308 \text{ K})}{88.31 \text{ kPa}}$$

$$= 1.001 \text{ m}^3 / \text{kg dry air}$$

$$\omega_1 = \frac{0.622 P_{v1}}{P_1 - P_{v1}} = \frac{0.622(1.689 \text{ kPa})}{(90 - 1.689) \text{ kPa}}$$

$$= 0.01189 \text{ kg H}_2\text{O/kg dry air}$$

$$h_1 = c_p T_1 + \omega_1 h_{g1}$$

$$= (1.005 \text{ kJ/kg} \cdot ^\circ\text{C})(35^\circ\text{C}) + (0.01189)(2564.6 \text{ kJ/kg})$$

$$= 65.68 \text{ kJ/kg dry air}$$

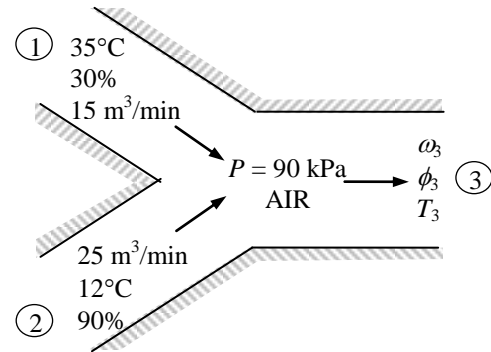

and

$$P_{v2} = \phi_2 P_{g2} = \phi_2 P_{\text{sat}@12^\circ\text{C}} = (0.90)(1.403 \text{ kPa}) = 1.262 \text{ kPa}$$

$$P_{a2} = P_2 - P_{v2} = 90 - 1.262 = 88.74 \text{ kPa}$$

$$\nu_2 = \frac{R_a T_2}{P_{a2}} = \frac{(0.287 \text{ kPa} \cdot \text{m}^3 / \text{kg} \cdot \text{K})(285 \text{ K})}{88.74 \text{ kPa}} = 0.9218 \text{ m}^3 / \text{kg dry air}$$

$$\omega_2 = \frac{0.622 P_{v2}}{P_2 - P_{v2}} = \frac{0.622(1.262 \text{ kPa})}{(90 - 1.262) \text{ kPa}} = 0.008849 \text{ kg H}_2\text{O/kg dry air}$$

$$h_2 = c_p T_2 + \omega_2 h_{g2} = (1.005 \text{ kJ/kg} \cdot ^\circ\text{C})(12^\circ\text{C}) + (0.008849)(2522.9 \text{ kJ/kg}) = 34.39 \text{ kJ/kg dry air}$$

Then the mass flow rate of dry air in each stream is

$$\dot{m}_{a1} = \frac{\dot{V}_1}{\nu_1} = \frac{150 \text{ m}^3 / \text{min}}{1.001 \text{ m}^3 / \text{kg dry air}} = 14.99 \text{ kg/min}$$

$$\dot{m}_{a2} = \frac{\dot{V}_2}{\nu_2} = \frac{25 \text{ m}^3 / \text{min}}{0.9218 \text{ m}^3 / \text{kg dry air}} = 27.12 \text{ kg/min}$$

From the conservation of mass,

$$\dot{m}_{a3} = \dot{m}_{a1} + \dot{m}_{a2} = 14.99 + 27.12 = 42.11 \text{ kg/min}$$

The specific humidity and the enthalpy of the mixture can be determined from Eqs. 14-24, which are obtained by combining the conservation of mass and energy equations for the adiabatic mixing of two streams:

$$\frac{\dot{m}_{a1}}{\dot{m}_{a2}} = \frac{\omega_2 - \omega_3}{\omega_3 - \omega_1} = \frac{h_2 - h_3}{h_3 - h_1} \longrightarrow \frac{14.99}{27.12} = \frac{0.008849 - \omega_3}{\omega_3 - 0.01189} = \frac{34.39 - h_3}{h_3 - 65.68}$$

which yields

$$h_3 = 45.52 \text{ kJ/kg dry air}$$

$$\omega_3 = \mathbf{0.009933 \text{ kg H}_2\text{O/kg dry air}}$$

These two properties fix the state of the mixture. Other properties are determined from

$$h_3 = c_p T_3 + \omega_3 h_{g3} \cong c_p T_3 + \omega_3 (2501.3 + 1.82 T_3)$$

$$45.52 \text{ kJ/kg} = (1.005 \text{ kJ/kg} \cdot ^\circ\text{C}) T_3 + (0.009933)(2500.9 + 1.82 T_3) \text{ kJ/kg} \longrightarrow T_3 = \mathbf{20.2^\circ\text{C}}$$

$$\omega_3 = \frac{0.622 P_{v3}}{P_3 - P_{v3}}$$

$$0.009933 = \frac{0.622 P_{v3}}{90 - P_{v3}} \longrightarrow P_{v3} = 1.415 \text{ kPa}$$

$$\phi_3 = \frac{P_{v3}}{P_{g3}} = \frac{P_{v3}}{P_{\text{sat}@T_3}} = \frac{1.415 \text{ kPa}}{2.370 \text{ kPa}} = 0.597 \text{ or } \mathbf{59.7\%}$$

Finally,

$$P_{a3} = P_3 - P_{v3} = 90 - 1.415 = 88.59 \text{ kPa}$$

$$\nu_3 = \frac{R_a T_3}{P_{a3}} = \frac{(0.287 \text{ kPa} \cdot \text{m}^3 / \text{kg} \cdot \text{K})(293.2 \text{ K})}{88.59 \text{ kPa}} = 0.9500 \text{ m}^3 / \text{kg dry air}$$

$$\dot{V}_3 = \dot{m}_{a3} \nu_3 = (42.11 \text{ kg/min})(0.9500 \text{ m}^3 / \text{kg}) = \mathbf{40.0 \text{ m}^3 / \text{min}}$$

14-102 A stream of warm air is mixed with a stream of saturated cool air. The temperature, the specific humidity, and the relative humidity of the mixture are to be determined.

Assumptions 1 Steady operating conditions exist 2 Dry air and water vapor are ideal gases. 3 The kinetic and potential energy changes are negligible. 4 The mixing section is adiabatic.

Properties The properties of each inlet stream are determined from the psychrometric chart (Fig. A-31 or EES) to be

$$h_1 = 99.4 \text{ kJ/kg dry air}$$

$$\omega_1 = 0.0246 \text{ kg H}_2\text{O/kg dry air}$$

and

$$h_2 = 34.1 \text{ kJ/kg dry air}$$

$$\omega_2 = 0.00873 \text{ kg H}_2\text{O/kg dry air}$$

Analysis The specific humidity and the enthalpy of the mixture can be determined from Eqs. 14-24, which are obtained by combining the conservation of mass and energy equations for the adiabatic mixing of two streams:

$$\frac{\dot{m}_{a1}}{\dot{m}_{a2}} = \frac{\omega_2 - \omega_3}{\omega_3 - \omega_1} = \frac{h_2 - h_3}{h_3 - h_1}$$

$$\frac{8}{10} = \frac{0.00873 - \omega_3}{\omega_3 - 0.0246} = \frac{34.1 - h_3}{h_3 - 99.4}$$

which yields,

$$(b) \quad \omega_3 = \mathbf{0.0158 \text{ kg H}_2\text{O/kg dry air}}$$

$$h_3 = 63.1 \text{ kJ/kg dry air}$$

These two properties fix the state of the mixture. Other properties of the mixture are determined from the psychrometric chart:

$$(a) \quad T_3 = \mathbf{22.8^\circ\text{C}}$$

$$(c) \quad \phi_3 = \mathbf{90.1\%}$$

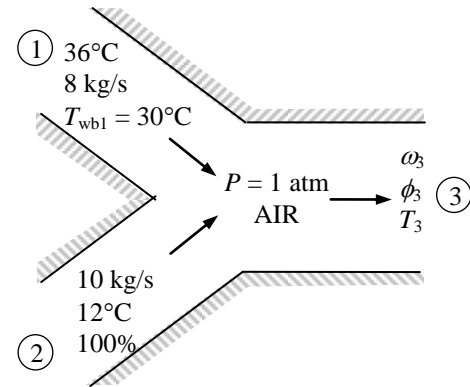



14-103 Problem 14-102 is reconsidered. The effect of the mass flow rate of saturated cool air stream on the mixture temperature, specific humidity, and relative humidity is to be investigated.

Analysis The problem is solved using EES, and the solution is given below.

```
P=101.325 [kPa]
Tdb[1]=36 [C]
Twb[1]=30 [C]
m_dot[1]=8 [kg/s]
Tdb[2]=12 [C]
Rh[2]=1.0
m_dot[2]=10 [kg/s]
P[1]=P
P[2]=P[1]
P[3]=P[1]
```

"Energy balance for the steady-flow mixing process:"

"We neglect the PE of the flow. Since we don't know the cross sectional area of the flow streams, we also neglect the KE of the flow."

```
E_dot_in - E_dot_out = DELTAE_dot_sys
DELTAE_dot_sys = 0 [kW]
E_dot_in = m_dot[1]*h[1]+m_dot[2]*h[2]
E_dot_out = m_dot[3]*h[3]
```

"Conservation of mass of dry air during mixing:"

```
m_dot[1]+m_dot[2] = m_dot[3]
```

"Conservation of mass of water vapor during mixing:"

```
m_dot[1]*w[1]+m_dot[2]*w[2] = m_dot[3]*w[3]
m_dot[1]=V_dot[1]/v[1]*convert(1/min,1/s)
m_dot[2]=V_dot[2]/v[2]*convert(1/min,1/s)
h[1]=ENTHALPY(AirH2O,T=Tdb[1],P=P[1],B=Twb[1])
Rh[1]=RELHUM(AirH2O,T=Tdb[1],P=P[1],B=Twb[1])
v[1]=VOLUME(AirH2O,T=Tdb[1],P=P[1],R=Rh[1])
w[1]=HUMRAT(AirH2O,T=Tdb[1],P=P[1],R=Rh[1])
h[2]=ENTHALPY(AirH2O,T=Tdb[2],P=P[2],R=Rh[2])
v[2]=VOLUME(AirH2O,T=Tdb[2],P=P[2],R=Rh[2])
w[2]=HUMRAT(AirH2O,T=Tdb[2],P=P[2],R=Rh[2])
Tdb[3]=TEMPERATURE(AirH2O,h=h[3],P=P[3],w=w[3])
Rh[3]=RELHUM(AirH2O,T=Tdb[3],P=P[3],w=w[3])
v[3]=VOLUME(AirH2O,T=Tdb[3],P=P[3],w=w[3])
Twb[2]=WETBULB(AirH2O,T=Tdb[2],P=P[2],R=RH[2])
Twb[3]=WETBULB(AirH2O,T=Tdb[3],P=P[3],R=RH[3])
m_dot[3]=V_dot[3]/v[3]*convert(1/min,1/s)
```

m ₂ [kga/s]	Tdb ₃ [C]	Rh ₃	w ₃ [kgw/kga]
0	36	0.6484	0.02461
2	31.31	0.7376	0.02143
4	28.15	0.7997	0.01931
6	25.88	0.8442	0.0178
8	24.17	0.8768	0.01667
10	22.84	0.9013	0.01579
12	21.77	0.92	0.01508
14	20.89	0.9346	0.0145
16	20.15	0.9461	0.01402

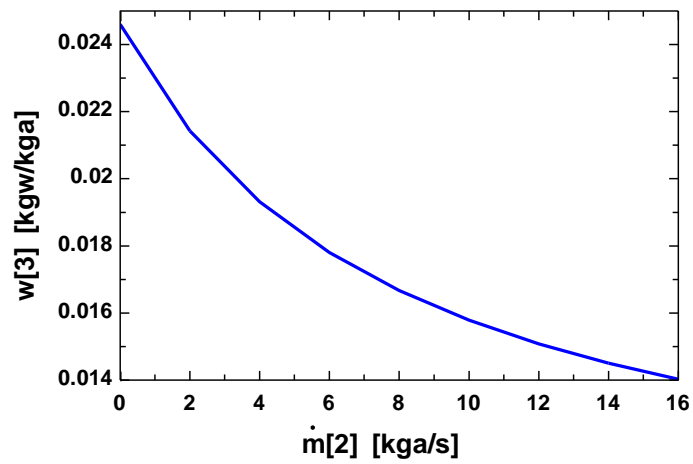
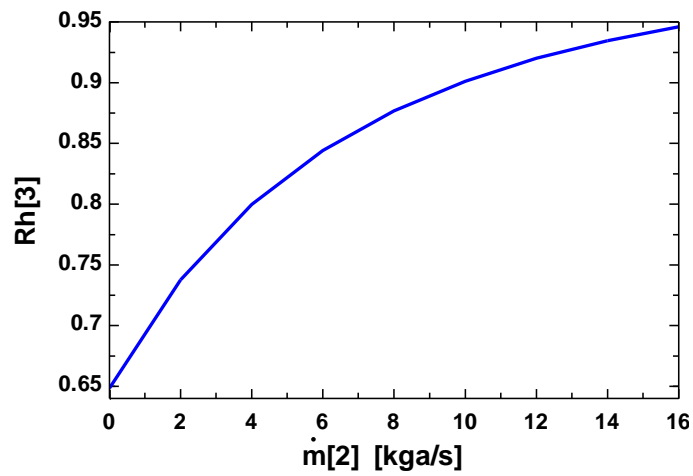
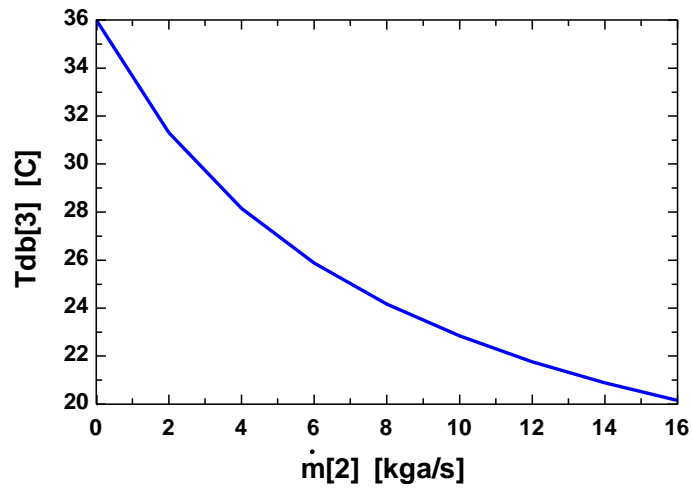

14-104E Two airstreams are mixed steadily. The mass flow ratio of the two streams for a specified mixture relative humidity and the relative humidity of the mixture are to be determined.

Assumptions 1 Steady operating conditions exist 2 Dry air and water vapor are ideal gases. 3 The kinetic and potential energy changes are negligible. 4 The mixing section is adiabatic.

Properties Properties of each inlet stream are determined from the psychrometric chart (Fig. A-31E or from EES) to be

$$h_1 = 20.3 \text{ Btu/lbmdry air}$$

$$\omega_1 = 0.0076 \text{ lbm H}_2\text{O/lbm dry air}$$

and

$$h_2 = 48.7 \text{ Btu/lbmdry air}$$

$$\omega_2 = 0.0246 \text{ lbm H}_2\text{O/lbm dry air}$$

Analysis An application of Eq. 14-24, which are obtained by combining the conservation of mass and energy equations for the adiabatic mixing of two streams gives

$$\frac{\dot{m}_{a1}}{\dot{m}_{a2}} = \frac{\omega_2 - \omega_3}{\omega_3 - \omega_1} = \frac{h_2 - h_3}{h_3 - h_1}$$

$$\frac{\dot{m}_{a1}}{\dot{m}_{a2}} = \frac{0.0246 - \omega_3}{\omega_3 - 0.0076} = \frac{48.7 - h_3}{h_3 - 20.3}$$

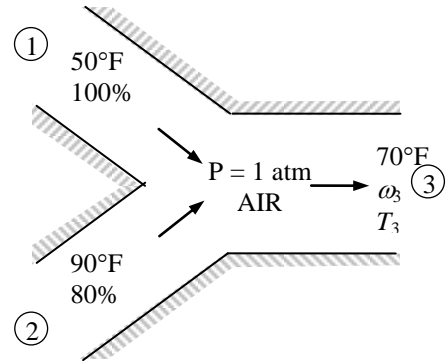

This equation cannot be solved directly. An iterative solution is needed. A mixture relative humidity ϕ_3 is selected. At this relative humidity and the given temperature (70°F), specific humidity and enthalpy are read from the psychrometric chart. These values are substituted into the above equation. If the equation is not satisfied, a new value of ϕ_3 is selected. This procedure is repeated until the equation is satisfied. Alternatively, EES software can be used. We used the following EES program to get these results:

$$\phi_3 = \mathbf{100\%}$$

$$\omega_3 = 0.0158 \text{ lbm H}_2\text{O/lbm dry air}$$

$$h_3 = 34.0 \text{ Btu/lbmdry air}$$

$$\frac{\dot{m}_{a1}}{\dot{m}_{a2}} = \mathbf{1.07}$$

"Given"

P=14.696 [psia]
 T_1=50 [F]
 phi_1=1.0
 T_2=90 [F]
 phi_2=0.80
 T_3=70 [F]

"Analysis"

Fluid\$='AirH2O'

"1st stream properties"

h_1=enthalpy(Fluid\$, T=T_1, P=P, R=phi_1)

w_1=humrat(Fluid\$, T=T_1, P=P, R=phi_1)

"2nd stream properties"

h_2=enthalpy(Fluid\$, T=T_2, P=P, R=phi_2)

w_2=humrat(Fluid\$, T=T_2, P=P, R=phi_2)

(w_2-w_3)/(w_3-w_1)=(h_2-h_3)/(h_3-h_1)

Ratio=(w_2-w_3)/(w_3-w_1)

"mixture properties"

phi_3=relhum(Fluid\$, h=h_3, P=P, T=T_3)

h_3=enthalpy(Fluid\$, R=phi_3, P=P, T=T_3)

Wet Cooling Towers

14-105C The working principle of a natural draft cooling tower is based on buoyancy. The air in the tower has a high moisture content, and thus is lighter than the outside air. This light moist air rises under the influence of buoyancy, inducing flow through the tower.

14-106C A spray pond cools the warm water by spraying it into the open atmosphere. They require 25 to 50 times the area of a wet cooling tower for the same cooling load.

14-107 Water is cooled by air in a cooling tower. The volume flow rate of air and the mass flow rate of the required makeup water are to be determined.

Assumptions 1 Steady operating conditions exist and thus mass flow rate of dry air remains constant during the entire process. 2 Dry air and water vapor are ideal gases. 3 The kinetic and potential energy changes are negligible. 4 The cooling tower is adiabatic.

Analysis (a) The mass flow rate of dry air through the tower remains constant ($\dot{m}_{a1} = \dot{m}_{a2} = \dot{m}_a$), but the mass flow rate of liquid water decreases by an amount equal to the amount of water that vaporizes in the tower during the cooling process. The water lost through evaporation must be made up later in the cycle to maintain steady operation. Applying the mass and energy balances yields

Dry Air Mass Balance:

$$\sum \dot{m}_{a,i} = \sum \dot{m}_{a,e} \longrightarrow \dot{m}_{a1} = \dot{m}_{a2} = \dot{m}_a$$

Water Mass Balance:

$$\begin{aligned} \sum \dot{m}_{w,i} &= \sum \dot{m}_{w,e} \longrightarrow \dot{m}_3 + \dot{m}_{a1}\omega_1 = \dot{m}_4 + \dot{m}_{a2}\omega_2 \\ \dot{m}_3 - \dot{m}_4 &= \dot{m}_a(\omega_2 - \omega_1) = \dot{m}_{\text{makeup}} \end{aligned}$$

Energy Balance:

$$\begin{aligned} \dot{E}_{\text{in}} - \dot{E}_{\text{out}} &= \Delta \dot{E}_{\text{system}} \stackrel{\text{no (steady)}}{=} 0 \\ \dot{E}_{\text{in}} &= \dot{E}_{\text{out}} \\ \sum \dot{m}_i h_i &= \sum \dot{m}_e h_e \quad \text{since } \dot{Q} = \dot{W} = 0 \\ 0 &= \sum \dot{m}_e h_e - \sum \dot{m}_i h_i \\ 0 &= \dot{m}_{a2} h_2 + \dot{m}_4 h_4 - \dot{m}_{a1} h_1 - \dot{m}_3 h_3 \\ 0 &= \dot{m}_a (h_2 - h_1) + (\dot{m}_3 - \dot{m}_{\text{makeup}}) h_4 - \dot{m}_3 h_3 \end{aligned}$$

Solving for \dot{m}_a ,

$$\dot{m}_a = \frac{\dot{m}_3(h_3 - h_4)}{(h_2 - h_1) - (\omega_2 - \omega_1)h_4}$$

From the psychrometric chart (Fig. A-31),

$$\begin{aligned} h_1 &= 49.9 \text{ kJ/kg dry air} \\ \omega_1 &= 0.0105 \text{ kg H}_2\text{O/kg dry air} \\ \nu_1 &= 0.853 \text{ m}^3/\text{kg dry air} \end{aligned}$$

and

$$\begin{aligned} h_2 &= 110.7 \text{ kJ/kg dry air} \\ \omega_2 &= 0.0307 \text{ kg H}_2\text{O/kg dry air} \end{aligned}$$

From Table A-4,

$$\begin{aligned} h_3 &\cong h_f @ 40^\circ\text{C} = 167.53 \text{ kJ/kg H}_2\text{O} \\ h_4 &\cong h_f @ 25^\circ\text{C} = 104.83 \text{ kJ/kg H}_2\text{O} \end{aligned}$$

Substituting,

$$\dot{m}_a = \frac{(90 \text{ kg/s})(167.53 - 104.83) \text{ kJ/kg}}{(110.7 - 49.9) \text{ kJ/kg} - (0.0307 - 0.0105)(104.83) \text{ kJ/kg}} = 96.2 \text{ kg/s}$$

Then the volume flow rate of air into the cooling tower becomes

$$\dot{V}_1 = \dot{m}_a \nu_1 = (96.2 \text{ kg/s})(0.854 \text{ m}^3/\text{kg}) = \mathbf{82.2 \text{ m}^3/\text{s}}$$

(b) The mass flow rate of the required makeup water is determined from

$$\dot{m}_{\text{makeup}} = \dot{m}_a(\omega_2 - \omega_1) = (96.2 \text{ kg/s})(0.0307 - 0.0105) = \mathbf{1.94 \text{ kg/s}}$$

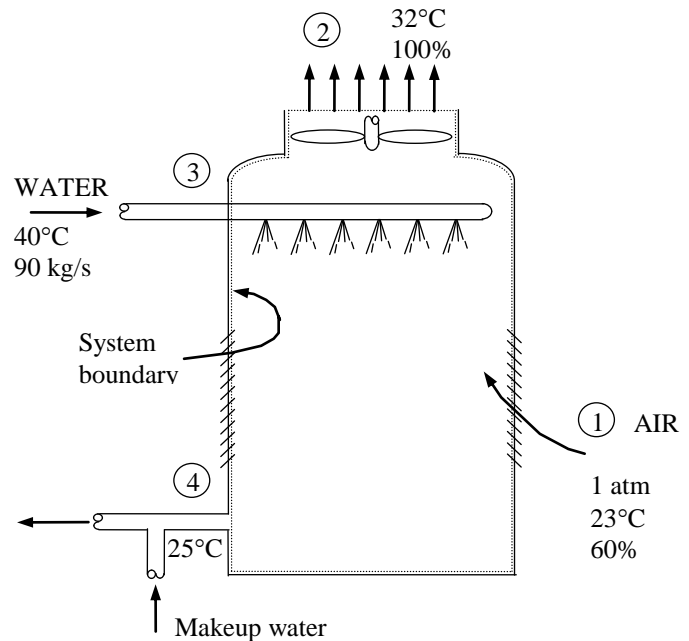

14-108E Water is cooled by air in a cooling tower. The volume flow rate of air and the mass flow rate of the required makeup water are to be determined.

Assumptions 1 Steady operating conditions exist and thus mass flow rate of dry air remains constant during the entire process. 2 Dry air and water vapor are ideal gases. 3 The kinetic and potential energy changes are negligible. 4 The cooling tower is adiabatic.

Analysis (a) The mass flow rate of dry air through the tower remains constant ($\dot{m}_{a1} = \dot{m}_{a2} = \dot{m}_a$), but the mass flow rate of liquid water decreases by an amount equal to the amount of water that vaporizes in the tower during the cooling process. The water lost through evaporation must be made up later in the cycle to maintain steady operation. Applying the mass balance and the energy balance equations yields

Dry Air Mass Balance:

$$\sum \dot{m}_{a,i} = \sum \dot{m}_{a,e} \longrightarrow \dot{m}_{a1} = \dot{m}_{a2} = \dot{m}_a$$

Water Mass Balance:

$$\begin{aligned} \sum \dot{m}_{w,i} &= \sum \dot{m}_{w,e} \longrightarrow \dot{m}_3 + \dot{m}_{a1}\omega_1 = \dot{m}_4 + \dot{m}_{a2}\omega_2 \\ \dot{m}_3 - \dot{m}_4 &= \dot{m}_a(\omega_2 - \omega_1) = \dot{m}_{\text{makeup}} \end{aligned}$$

Energy Balance:

$$\begin{aligned} \dot{E}_{\text{in}} - \dot{E}_{\text{out}} &= \Delta \dot{E}_{\text{system}} \stackrel{\text{no (steady)}}{=} 0 \\ \dot{E}_{\text{in}} &= \dot{E}_{\text{out}} \\ \sum \dot{m}_i h_i &= \sum \dot{m}_e h_e \quad (\text{since } \dot{Q} = \dot{W} = 0) \\ 0 &= \sum \dot{m}_e h_e - \sum \dot{m}_i h_i \\ 0 &= \dot{m}_{a2} h_2 + \dot{m}_4 h_4 - \dot{m}_{a1} h_1 - \dot{m}_3 h_3 \\ 0 &= \dot{m}_a (h_2 - h_1) + (\dot{m}_3 - \dot{m}_{\text{makeup}}) h_4 - \dot{m}_3 h_3 \end{aligned}$$

Solving for \dot{m}_a ,

$$\dot{m}_a = \frac{\dot{m}_3(h_3 - h_4)}{(h_2 - h_1) - (\omega_2 - \omega_1)h_4}$$

From the psychrometric chart (Fig. A-31),

$$\begin{aligned} h_1 &= 30.9 \text{ Btu/lbm dry air} \\ \omega_1 &= 0.0115 \text{ lbm H}_2\text{O/lbm dry air} \\ \nu_1 &= 13.76 \text{ ft}^3/\text{lbm dry air} \end{aligned}$$

and

$$\begin{aligned} h_2 &= 63.2 \text{ Btu/lbm dry air} \\ \omega_2 &= 0.0366 \text{ lbm H}_2\text{O/lbm dry air} \end{aligned}$$

From Table A-4E,

$$\begin{aligned} h_3 &\cong h_f @ 110^\circ\text{F} = 78.02 \text{ Btu/lbm H}_2\text{O} \\ h_4 &\cong h_f @ 80^\circ\text{F} = 48.07 \text{ Btu/lbm H}_2\text{O} \end{aligned}$$

Substituting,

$$\dot{m}_a = \frac{(100 \text{ lbm/s})(78.02 - 48.07) \text{ Btu/lbm}}{(63.2 - 30.9) \text{ Btu/lbm} - (0.0366 - 0.0115)(48.07) \text{ Btu/lbm}} = 96.3 \text{ lbm/s}$$

Then the volume flow rate of air into the cooling tower becomes

$$\dot{V}_1 = \dot{m}_a \nu_1 = (96.3 \text{ lbm/s})(13.76 \text{ ft}^3/\text{lbm}) = \mathbf{1325 \text{ ft}^3/\text{s}}$$

(b) The mass flow rate of the required makeup water is determined from

$$\dot{m}_{\text{makeup}} = \dot{m}_a(\omega_2 - \omega_1) = (96.3 \text{ lbm/s})(0.0366 - 0.0115) = \mathbf{2.42 \text{ lbm/s}}$$

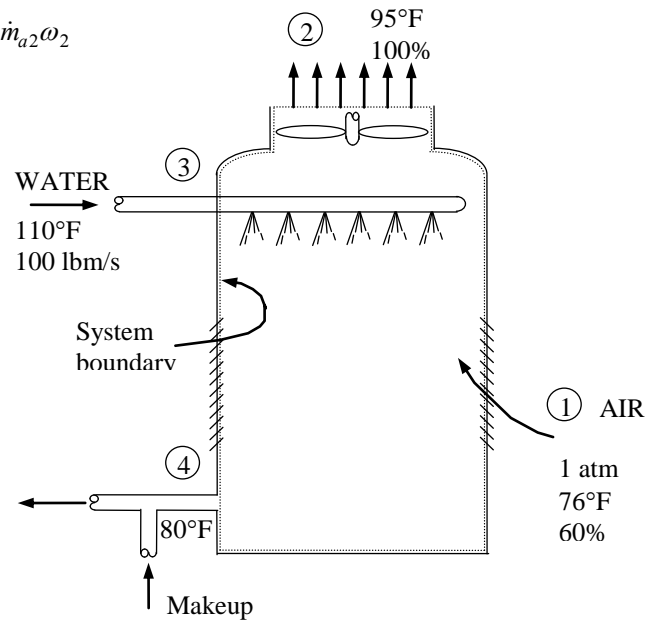

14-109 Water is cooled by air in a cooling tower. The volume flow rate of air and the mass flow rate of the required makeup water are to be determined.

Assumptions 1 Steady operating conditions exist and thus mass flow rate of dry air remains constant during the entire process. **2** Dry air and water vapor are ideal gases. **3** The kinetic and potential energy changes are negligible. **4** The cooling tower is adiabatic.

Analysis (a) The mass flow rate of dry air through the tower remains constant ($\dot{m}_{a1} = \dot{m}_{a2} = \dot{m}_a$), but the mass flow rate of liquid water decreases by an amount equal to the amount of water that vaporizes in the tower during the cooling process. The water lost through evaporation must be made up later in the cycle to maintain steady operation. Applying the mass and energy balances yields

Dry Air Mass Balance:

$$\sum \dot{m}_{a,i} = \sum \dot{m}_{a,e} \longrightarrow \dot{m}_{a1} = \dot{m}_{a2} = \dot{m}_a$$

Water Mass Balance:

$$\begin{aligned} \sum \dot{m}_{w,i} &= \sum \dot{m}_{w,e} \rightarrow \dot{m}_3 + \dot{m}_{a1}\omega_1 = \dot{m}_4 + \dot{m}_{a2}\omega_2 \\ \dot{m}_3 - \dot{m}_4 &= \dot{m}_a(\omega_2 - \omega_1) = \dot{m}_{\text{makeup}} \end{aligned}$$

Energy Balance:

$$\begin{aligned} \dot{E}_{\text{in}} - \dot{E}_{\text{out}} &= \Delta \dot{E}_{\text{system}} \stackrel{\approx 0 \text{ (steady)}}{=} 0 \\ \dot{E}_{\text{in}} &= \dot{E}_{\text{out}} \\ \sum \dot{m}_i h_i &= \sum \dot{m}_e h_e \quad (\text{since } \dot{Q} = \dot{W} = 0) \\ 0 &= \sum \dot{m}_e h_e - \sum \dot{m}_i h_i \\ 0 &= \dot{m}_{a2} h_2 + \dot{m}_4 h_4 - \dot{m}_{a1} h_1 - \dot{m}_3 h_3 \\ 0 &= \dot{m}_a (h_2 - h_1) + (\dot{m}_3 - \dot{m}_{\text{makeup}}) h_4 - \dot{m}_3 h_3 \end{aligned}$$

Solving for \dot{m}_a ,

$$\dot{m}_a = \frac{\dot{m}_3(h_3 - h_4)}{(h_2 - h_1) - (\omega_2 - \omega_1)h_4}$$

From the psychrometric chart (Fig. A-31 or EES),

$$\begin{aligned} h_1 &= 44.70 \text{ kJ/kg dry air} \\ \omega_1 &= 0.008875 \text{ kg H}_2\text{O/kg dry air} \\ \nu_1 &= 0.8480 \text{ m}^3/\text{kg dry air} \end{aligned}$$

and

$$\begin{aligned} h_2 &= 96.13 \text{ kJ/kg dry air} \\ \omega_2 &= 0.02579 \text{ kg H}_2\text{O/kg dry air} \end{aligned}$$

From Table A-4,

$$\begin{aligned} h_3 &\cong h_f @ 40^\circ\text{C} = 167.53 \text{ kJ/kg H}_2\text{O} \\ h_4 &\cong h_f @ 33^\circ\text{C} = 138.28 \text{ kJ/kg H}_2\text{O} \end{aligned}$$

Substituting,

$$\dot{m}_a = \frac{(60 \text{ kg/s})(167.53 - 138.28) \text{ kJ/kg}}{(96.13 - 44.70) \text{ kJ/kg} - (0.02579 - 0.008875)(138.28) \text{ kJ/kg}} = 35.76 \text{ kg/s}$$

Then the volume flow rate of air into the cooling tower becomes

$$\dot{V}_1 = \dot{m}_a \nu_1 = (35.76 \text{ kg/s})(0.8480 \text{ m}^3/\text{kg}) = \mathbf{30.3 \text{ m}^3/\text{s}}$$

(b) The mass flow rate of the required makeup water is determined from

$$\dot{m}_{\text{makeup}} = \dot{m}_a(\omega_2 - \omega_1) = (35.76 \text{ kg/s})(0.02579 - 0.008875) = \mathbf{0.605 \text{ kg/s}}$$

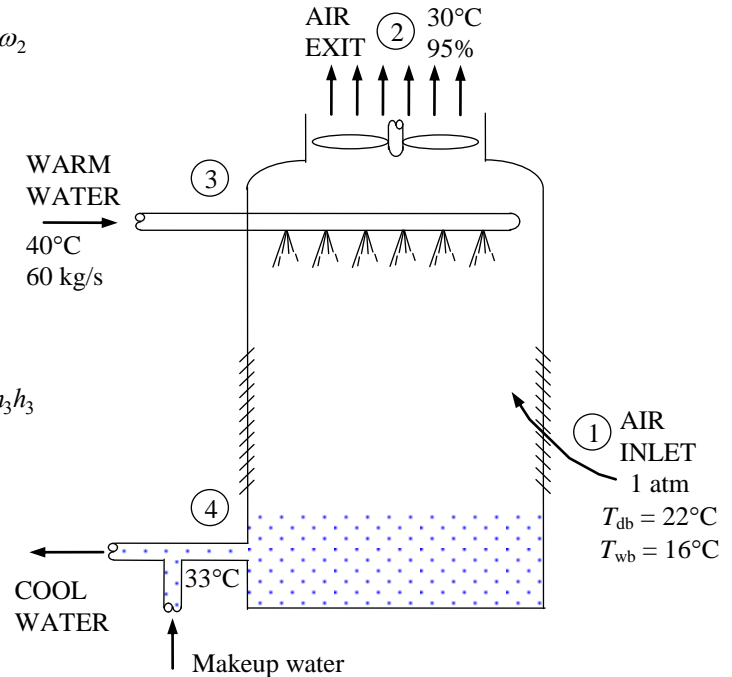

14-110 Water is cooled by air in a cooling tower. The volume flow rate of air and the mass flow rate of the required makeup water are to be determined.

Assumptions 1 Steady operating conditions exist and thus mass flow rate of dry air remains constant during the entire process. **2** Dry air and water vapor are ideal gases. **3** The kinetic and potential energy changes are negligible. **4** The cooling tower is adiabatic.

Analysis (a) The mass flow rate of dry air through the tower remains constant ($\dot{m}_{a1} = \dot{m}_{a2} = \dot{m}_a$), but the mass flow rate of liquid water decreases by an amount equal to the amount of water that vaporizes in the tower during the cooling process. The water lost through evaporation must be made up later in the cycle to maintain steady operation. Applying the mass and energy balances yields

Dry Air Mass Balance:

$$\sum \dot{m}_{a,i} = \sum \dot{m}_{a,e} \longrightarrow \dot{m}_{a1} = \dot{m}_{a2} = \dot{m}_a$$

Water Mass Balance:

$$\sum \dot{m}_{w,i} = \sum \dot{m}_{w,e}$$

$$\dot{m}_3 + \dot{m}_{a1}\omega_1 = \dot{m}_4 + \dot{m}_{a2}\omega_2$$

$$\dot{m}_3 - \dot{m}_4 = \dot{m}_a(\omega_2 - \omega_1) = \dot{m}_{\text{makeup}}$$

Energy Balance:

$$\dot{E}_{\text{in}} - \dot{E}_{\text{out}} = \Delta \dot{E}_{\text{system}} \stackrel{\text{no (steady)}}{=} 0 \longrightarrow \dot{E}_{\text{in}} = \dot{E}_{\text{out}}$$

$$\sum \dot{m}_i h_i = \sum \dot{m}_e h_e \quad (\text{since } \dot{Q} = \dot{W} = 0)$$

$$0 = \sum \dot{m}_e h_e - \sum \dot{m}_i h_i$$

$$0 = \dot{m}_{a2}h_2 + \dot{m}_4h_4 - \dot{m}_{a1}h_1 - \dot{m}_3h_3$$

$$0 = \dot{m}_a(h_2 - h_1) + (\dot{m}_3 - \dot{m}_{\text{makeup}})h_4 - \dot{m}_3h_3$$

$$\dot{m}_a = \frac{\dot{m}_3(h_3 - h_4)}{(h_2 - h_1) - (\omega_2 - \omega_1)h_4}$$

The properties of air at the inlet and the exit are

$$P_{v1} = \phi_1 P_{g1} = \phi_1 P_{\text{sat}@20^\circ\text{C}} = (0.70)(2.3392 \text{ kPa}) = 1.637 \text{ kPa}$$

$$P_{a1} = P_1 - P_{v1} = 96 - 1.637 = 94.363 \text{ kPa}$$

$$v_1 = \frac{R_a T_1}{P_{a1}} = \frac{(0.287 \text{ kPa} \cdot \text{m}^3 / \text{kg} \cdot \text{K})(293 \text{ K})}{94.363 \text{ kPa}} = 0.891 \text{ m}^3 / \text{kg dry air}$$

$$\omega_1 = \frac{0.622 P_{v1}}{P_1 - P_{v1}} = \frac{0.622(1.637 \text{ kPa})}{(96 - 1.637) \text{ kPa}} = 0.0108 \text{ kg H}_2\text{O/kg dry air}$$

$$h_1 = c_p T_1 + \omega_1 h_{g1} = (1.005 \text{ kJ/kg} \cdot ^\circ\text{C})(20^\circ\text{C}) + (0.0108)(2537.4 \text{ kJ/kg}) = 47.5 \text{ kJ/kg dry air}$$

and

$$P_{v2} = \phi_2 P_{g2} = \phi_2 P_{\text{sat}@35^\circ\text{C}} = (1.00)(5.6291 \text{ kPa}) = 5.6291 \text{ kPa}$$

$$\omega_2 = \frac{0.622 P_{v2}}{P_2 - P_{v2}} = \frac{0.622(5.6291 \text{ kPa})}{(96 - 5.6291) \text{ kPa}} = 0.0387 \text{ kg H}_2\text{O/kg dry air}$$

$$h_2 = c_p T_2 + \omega_2 h_{g2} = (1.005 \text{ kJ/kg} \cdot ^\circ\text{C})(35^\circ\text{C}) + (0.0387)(2564.6 \text{ kJ/kg}) = 134.4 \text{ kJ/kg dry air}$$

From Table A-4,

$$h_3 \cong h_f @ 40^\circ\text{C} = 167.53 \text{ kJ/kg H}_2\text{O}$$

$$h_4 \cong h_f @ 30^\circ\text{C} = 125.74 \text{ kJ/kg H}_2\text{O}$$

Substituting,

$$\dot{m}_a = \frac{(25 \text{ kg/s})(167.53 - 125.74) \text{ kJ/kg}}{(134.4 - 47.5) \text{ kJ/kg} - (0.0387 - 0.0108)(125.74) \text{ kJ/kg}} = 12.53 \text{ kg/s}$$

Then the volume flow rate of air into the cooling tower becomes

$$\dot{V}_1 = \dot{m}_a v_1 = (12.53 \text{ kg/s})(0.891 \text{ m}^3 / \text{kg}) = \mathbf{11.2 \text{ m}^3 / \text{s}}$$

(b) The mass flow rate of the required makeup water is determined from

$$\dot{m}_{\text{makeup}} = \dot{m}_a(\omega_2 - \omega_1) = (12.53 \text{ kg/s})(0.0387 - 0.0108) = \mathbf{0.35 \text{ kg/s}}$$

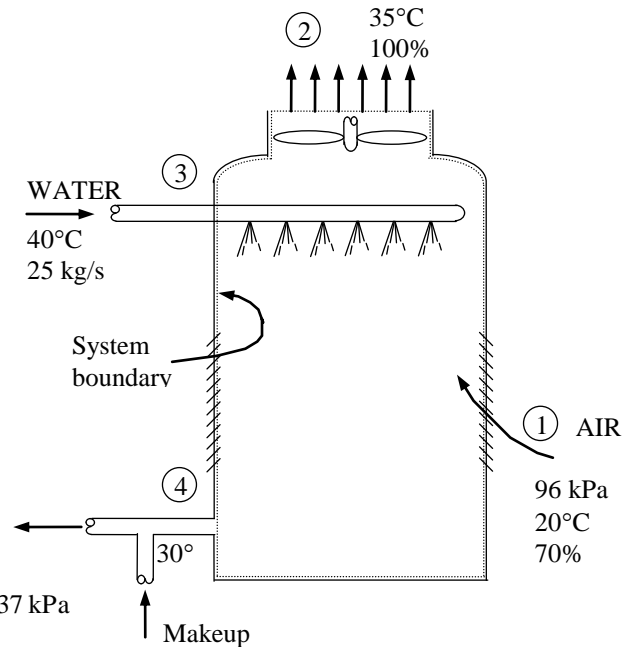

14-111E Water is cooled by air in a cooling tower. The mass flow rate of dry air is to be determined.

Assumptions 1 Steady operating conditions exist and thus mass flow rate of dry air remains constant during the entire process. 2 Dry air and water vapor are ideal gases. 3 The kinetic and potential energy changes are negligible. 4 The cooling tower is adiabatic.

Analysis The mass flow rate of dry air through the tower remains constant ($\dot{m}_{a1} = \dot{m}_{a2} = \dot{m}_a$), but the mass flow rate of liquid water decreases by an amount equal to the amount of water that vaporizes in the tower during the cooling process. The water lost through evaporation must be made up later in the cycle to maintain steady operation. Applying the mass and energy balances yields

Dry Air Mass Balance:

$$\sum \dot{m}_{a,i} = \sum \dot{m}_{a,e} \longrightarrow \dot{m}_{a1} = \dot{m}_{a2} = \dot{m}_a$$

Water Mass Balance:

$$\begin{aligned} \sum \dot{m}_{w,i} &= \sum \dot{m}_{w,e} \rightarrow \dot{m}_3 + \dot{m}_{a1}\omega_1 = \dot{m}_4 + \dot{m}_{a2}\omega_2 \\ \dot{m}_3 - \dot{m}_4 &= \dot{m}_a(\omega_2 - \omega_1) = \dot{m}_{\text{makeup}} \end{aligned}$$

Energy Balance:

$$\begin{aligned} \dot{E}_{\text{in}} - \dot{E}_{\text{out}} &= \Delta \dot{E}_{\text{system}} \stackrel{\text{no (steady)}}{=} 0 \\ \dot{E}_{\text{in}} &= \dot{E}_{\text{out}} \\ \sum \dot{m}_i h_i &= \sum \dot{m}_e h_e \quad (\text{since } \dot{Q} = \dot{W} = 0) \\ 0 &= \sum \dot{m}_e h_e - \sum \dot{m}_i h_i \\ 0 &= \dot{m}_{a2} h_2 + \dot{m}_4 h_4 - \dot{m}_{a1} h_1 - \dot{m}_3 h_3 \\ 0 &= \dot{m}_a (h_2 - h_1) + (\dot{m}_3 - \dot{m}_{\text{makeup}}) h_4 - \dot{m}_3 h_3 \end{aligned}$$

Solving for \dot{m}_a ,

$$\dot{m}_a = \frac{\dot{m}_3 (h_3 - h_4)}{(h_2 - h_1) - (\omega_2 - \omega_1) h_4}$$

From the psychrometric chart (Fig. A-31E),

$$\begin{aligned} h_1 &= 19.9 \text{ Btu/lbm dry air} \\ \omega_1 &= 0.00391 \text{ lbm H}_2\text{O/lbm dry air} \\ \nu_1 &= 13.31 \text{ ft}^3/\text{lbm dry air} \end{aligned}$$

and

$$\begin{aligned} h_2 &= 34.3 \text{ Btu/lbm dry air} \\ \omega_2 &= 0.0149 \text{ lbm H}_2\text{O/lbm dry air} \end{aligned}$$

From Table A-4E,

$$\begin{aligned} h_3 &\cong h_f @ 95^\circ\text{C} = 63.04 \text{ Btu/lbm H}_2\text{O} \\ h_4 &\cong h_f @ 80^\circ\text{C} = 48.07 \text{ Btu/lbm H}_2\text{O} \end{aligned}$$

Substituting,

$$\dot{m}_a = \frac{(3 \text{ lbm/s})(63.04 - 48.07) \text{ Btu/lbm}}{(34.3 - 19.9) \text{ Btu/lbm} - (0.0149 - 0.00391)(48.07) \text{ Btu/lbm}} = \mathbf{3.22 \text{ lbm/s}}$$

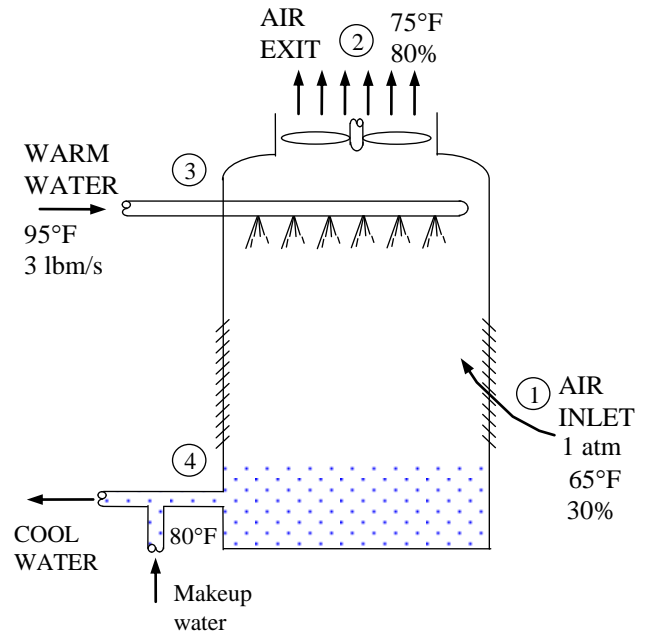

14-112E Water is cooled by air in a cooling tower. The exergy lost in the cooling tower is to be determined.

Assumptions 1 Steady operating conditions exist and thus mass flow rate of dry air remains constant during the entire process. 2 Dry air and water vapor are ideal gases. 3 The kinetic and potential energy changes are negligible. 4 The cooling tower is adiabatic.

Analysis The mass flow rate of dry air through the tower remains constant ($\dot{m}_{a1} = \dot{m}_{a2} = \dot{m}_a$), but the mass flow rate of liquid water decreases by an amount equal to the amount of water that vaporizes in the tower during the cooling process. The water lost through evaporation must be made up later in the cycle to maintain steady operation. Applying the mass and energy balances yields

Dry Air Mass Balance:

$$\sum \dot{m}_{a,i} = \sum \dot{m}_{a,e} \longrightarrow \dot{m}_{a1} = \dot{m}_{a2} = \dot{m}_a$$

Water Mass Balance:

$$\begin{aligned} \sum \dot{m}_{w,i} &= \sum \dot{m}_{w,e} \rightarrow \dot{m}_3 + \dot{m}_{a1}\omega_1 = \dot{m}_4 + \dot{m}_{a2}\omega_2 \\ \dot{m}_3 - \dot{m}_4 &= \dot{m}_a(\omega_2 - \omega_1) = \dot{m}_{\text{makeup}} \end{aligned}$$

Energy Balance:

$$\begin{aligned} \dot{E}_{\text{in}} - \dot{E}_{\text{out}} &= \Delta \dot{E}_{\text{system}} \stackrel{\text{no (steady)}}{=} 0 \\ \dot{E}_{\text{in}} &= \dot{E}_{\text{out}} \\ \sum \dot{m}_i h_i &= \sum \dot{m}_e h_e \quad (\text{since } \dot{Q} = \dot{W} = 0) \\ 0 &= \sum \dot{m}_e h_e - \sum \dot{m}_i h_i \\ 0 &= \dot{m}_{a2} h_2 + \dot{m}_4 h_4 - \dot{m}_{a1} h_1 - \dot{m}_3 h_3 \\ 0 &= \dot{m}_a (h_2 - h_1) + (\dot{m}_3 - \dot{m}_{\text{makeup}}) h_4 - \dot{m}_3 h_3 \end{aligned}$$

Solving for \dot{m}_a ,

$$\dot{m}_a = \frac{\dot{m}_3 (h_3 - h_4)}{(h_2 - h_1) - (\omega_2 - \omega_1) h_4}$$

From the psychrometric chart (Fig. A-31E),

$$\begin{aligned} h_1 &= 19.9 \text{ Btu/lbm dry air} \\ \omega_1 &= 0.00391 \text{ lbm H}_2\text{O/lbm dry air} \\ \nu_1 &= 13.31 \text{ ft}^3/\text{lbm dry air} \end{aligned}$$

and

$$\begin{aligned} h_2 &= 34.3 \text{ Btu/lbm dry air} \\ \omega_2 &= 0.0149 \text{ lbm H}_2\text{O/lbm dry air} \end{aligned}$$

From Table A-4,

$$\begin{aligned} h_3 &\cong h_f @ 95^\circ\text{F} = 63.04 \text{ Btu/lbm H}_2\text{O} \\ h_4 &\cong h_f @ 80^\circ\text{F} = 48.07 \text{ Btu/lbm H}_2\text{O} \end{aligned}$$

Substituting,

$$\dot{m}_a = \frac{(3 \text{ lbm/s})(63.04 - 48.07) \text{ Btu/lbm}}{(34.3 - 19.9) \text{ Btu/lbm} - (0.0149 - 0.00391)(48.07) \text{ Btu/lbm}} = 3.22 \text{ lbm/s}$$

The mass of water stream at state 3 per unit mass of dry air is

$$m_3 = \frac{\dot{m}_3}{\dot{m}_a} = \frac{3 \text{ lbm water/s}}{3.22 \text{ lbm dry air/s}} = 0.9317 \text{ lbm water/lbm dry air}$$

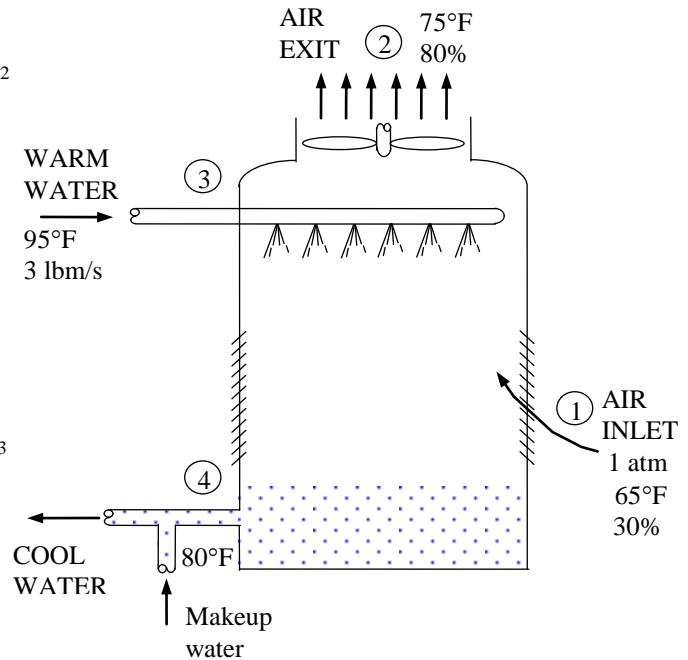

The mass flow rate of water stream at state 4 per unit mass of dry air is

$$m_4 = m_3 - (\omega_2 - \omega_1) = 0.9317 - (0.0149 - 0.00391) = 0.9207 \text{ lbm water/lbm dry air}$$

The entropies of water streams are

$$s_3 = s_f @ 95^\circ\text{F} = 0.12065 \text{ Btu/lbm} \cdot \text{R}$$

$$s_4 = s_f @ 80^\circ\text{F} = 0.09328 \text{ Btu/lbm} \cdot \text{R}$$

The entropy change of water stream is

$$\Delta s_{\text{water}} = m_4 s_4 - m_3 s_3 = 0.9207 \times 0.09328 - 0.9317 \times 0.12065 = -0.02653 \text{ Btu/R} \cdot \text{lbm dry air}$$

The entropies of water vapor in the air stream are

$$s_{g1} = s_g @ 65^\circ\text{F} = 2.0788 \text{ Btu/lbm} \cdot \text{R}$$

$$s_{g2} = s_g @ 80^\circ\text{F} = 2.0352 \text{ Btu/lbm} \cdot \text{R}$$

The entropy change of water vapor in the air stream is

$$\Delta s_{\text{vapor}} = \omega_2 s_{g2} - \omega_1 s_{g1} = 0.0149 \times 2.0352 - 0.00391 \times 2.0788 = 0.02220 \text{ Btu/R} \cdot \text{lbm dry air}$$

The partial pressures of water vapor and dry air for air streams are

$$P_{v1} = \phi_1 P_{g1} = \phi_1 P_{\text{sat} @ 65^\circ\text{F}} = (0.30)(0.30578 \text{ psia}) = 0.0917 \text{ psia}$$

$$P_{a1} = P_1 - P_{v1} = 14.696 - 0.0917 = 14.60 \text{ psia}$$

$$P_{v2} = \phi_2 P_{g2} = \phi_2 P_{\text{sat} @ 75^\circ\text{F}} = (0.80)(0.43016 \text{ psia}) = 0.3441 \text{ psia}$$

$$P_{a2} = P_2 - P_{v2} = 14.696 - 0.3441 = 14.35 \text{ psia}$$

The entropy change of dry air is

$$\begin{aligned} \Delta s_a &= s_2 - s_1 = c_p \ln \frac{T_2}{T_1} - R \ln \frac{P_{a2}}{P_{a1}} \\ &= (0.240) \ln \frac{535}{525} - (0.06855) \ln \frac{14.35}{14.60} = 0.005712 \text{ Btu/lbm dry air} \end{aligned}$$

The entropy generation in the cooling tower is the total entropy change:

$$s_{\text{gen}} = \Delta s_{\text{water}} + \Delta s_{\text{vapor}} + \Delta s_a = -0.02653 + 0.02220 + 0.005712 = 0.001382 \text{ Btu/R} \cdot \text{lbm dry air}$$

Finally, the exergy destruction per unit mass of dry air is

$$x_{\text{dest}} = T_0 s_{\text{gen}} = (525 \text{ R})(0.001382 \text{ Btu/R} \cdot \text{lbm dry air}) = \mathbf{0.726 \text{ Btu/lbm dry air}}$$

Review Problems

14-113 Dry air flows over a water body at constant pressure and temperature until it is saturated. The molar analysis of the saturated air and the density of air before and after the process are to be determined.

Assumptions The air and the water vapor are ideal gases.

Properties The molar masses of N_2 , O_2 , Ar, and H_2O are 28.0, 32.0, 39.9 and 18 kg / kmol, respectively (Table A-1). The molar analysis of dry air is given to be 78.1 percent N_2 , 20.9 percent O_2 , and 1 percent Ar. The saturation pressure of water at 25°C is 3.1698 kPa (Table A-4). Also, 1 atm = 101.325 kPa.

Analysis (a) Noting that the total pressure remains constant at 101.32 kPa during this process, the partial pressure of air becomes

$$P = P_{\text{air}} + P_{\text{vapor}} \rightarrow P_{\text{air}} = P - P_{\text{vapor}} = 101.325 - 3.1698 = 98.155 \text{ kPa}$$

Then the molar analysis of the saturated air becomes

$$y_{H_2O} = \frac{P_{H_2O}}{P} = \frac{3.1698}{101.325} = \mathbf{0.0313}$$

$$y_{N_2} = \frac{P_{N_2}}{P} = \frac{y_{N_2,\text{dry}} P_{\text{dry air}}}{P} = \frac{0.781(98.155 \text{ kPa})}{101.325} = \mathbf{0.7566}$$

$$y_{O_2} = \frac{P_{O_2}}{P} = \frac{y_{O_2,\text{dry}} P_{\text{dry air}}}{P} = \frac{0.209(98.155 \text{ kPa})}{101.325} = \mathbf{0.2025}$$

$$y_{Ar} = \frac{P_{Ar}}{P} = \frac{y_{Ar,\text{dry}} P_{\text{dry air}}}{P} = \frac{0.01(98.155 \text{ kPa})}{101.325} = \mathbf{0.0097}$$

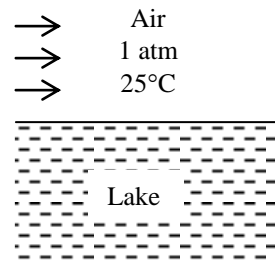

(b) The molar masses of dry and saturated air are

$$M_{\text{dry air}} = \sum y_i M_i = 0.781 \times 28.0 + 0.209 \times 32.0 + 0.01 \times 39.9 = 29.0 \text{ kg / kmol}$$

$$M_{\text{sat. air}} = \sum y_i M_i = 0.7566 \times 28.0 + 0.2025 \times 32.0 + 0.0097 \times 39.9 + 0.0313 \times 18 = 28.62 \text{ kg / kmol}$$

Then the densities of dry and saturated air are determined from the ideal gas relation to be

$$\rho_{\text{dry air}} = \frac{P}{(R_u / M_{\text{dry air}})T} = \frac{101.325 \text{ kPa}}{[(8.314 \text{ kPa} \cdot \text{m}^3 / \text{kmol} \cdot \text{K}) / 29.0 \text{ kg / kmol}](25 + 273) \text{ K}} = \mathbf{1.186 \text{ kg / m}^3}$$

$$\rho_{\text{sat. air}} = \frac{P}{(R_u / M_{\text{sat air}})T} = \frac{101.325 \text{ kPa}}{[(8.314 \text{ kPa} \cdot \text{m}^3 / \text{kmol} \cdot \text{K}) / 28.62 \text{ kg / kmol}](25 + 273) \text{ K}} = \mathbf{1.170 \text{ kg / m}^3}$$

Discussion We conclude that the density of saturated air is less than that of the dry air, as expected. This is due to the molar mass of water being less than that of dry air.

14-114E The error involved in assuming the density of air to remain constant during a humidification process is to be determined.

Properties The density of moist air before and after the humidification process is determined from the psychrometric chart (Fig. A-31E) to be

$$\left. \begin{array}{l} T_1 = 80^\circ\text{F} \\ \phi_1 = 25\% \end{array} \right\} \rho_{\text{air},1} = 0.0729 \text{ lbm/ft}^3$$

$$\left. \begin{array}{l} T_1 = 80^\circ\text{F} \\ \phi_1 = 75\% \end{array} \right\} \rho_{\text{air},2} = 0.0716 \text{ lbm/ft}^3$$

Analysis The error involved as a result of assuming constant air density is then determined to be

$$\% \text{Error} = \frac{\Delta \rho_{\text{air}}}{\rho_{\text{air},1}} \times 100 = \frac{(0.0729 - 0.0716) \text{ lbm/ft}^3}{0.0729 \text{ lbm/ft}^3} \times 100 = \mathbf{1.7\%}$$

which is acceptable for most engineering purposes.

14-115 Air is compressed by a compressor and then cooled to the ambient temperature at high pressure. It is to be determined if there will be any condensation in the compressed air lines.

Assumptions The air and the water vapor are ideal gases.

Properties The saturation pressure of water at 20°C is 2.3392 kPa (Table A-4)..

Analysis The vapor pressure of air before compression is

$$P_{v1} = \phi_1 P_g = \phi_1 P_{\text{sat}@25^\circ\text{C}} = (0.50)(2.3392 \text{ kPa}) = 1.17 \text{ kPa}$$

The pressure ratio during the compression process is $(800 \text{ kPa})/(92 \text{ kPa}) = 8.70$. That is, the pressure of air and any of its components increases by 8.70 times. Then the vapor pressure of air after compression becomes

$$P_{v2} = P_{v1} \times (\text{Pressure ratio}) = (1.17 \text{ kPa})(8.70) = 10.2 \text{ kPa}$$

The dew-point temperature of the air at this vapor pressure is

$$T_{\text{dp}} = T_{\text{sat}@P_{v2}} = T_{\text{sat}@10.2 \text{ kPa}} = 46.1^\circ\text{C}$$

which is greater than 20°C. Therefore, part of the moisture in the compressed air will **condense** when air is cooled to 20°C.

14-116E The required size of an evaporative cooler in cfm (ft^3/min) for an 8-ft high house is determined by multiplying the floor area of the house by 4. An equivalent rule is to be obtained in SI units.

Analysis Noting that $1 \text{ ft} = 0.3048 \text{ m}$ and thus $1 \text{ ft}^2 = 0.0929 \text{ m}^2$ and $1 \text{ ft}^3 = 0.0283 \text{ m}^3$, and noting that a flow rate of $4 \text{ ft}^3/\text{min}$ is required per ft^2 of floor area, the required flow rate in SI units per m^2 of floor area is determined to

$$1 \text{ ft}^2 \leftrightarrow 4 \text{ ft}^3 / \text{min}$$

$$0.0929 \text{ m}^2 \leftrightarrow 4 \times 0.0283 \text{ m}^3 / \text{min}$$

$$1 \text{ m}^2 \leftrightarrow 1.22 \text{ m}^3 / \text{min}$$

Therefore, a flow rate of **$1.22 \text{ m}^3/\text{min}$** is required per m^2 of floor area.

14-117 A cooling tower with a cooling capacity of 105 kW is claimed to evaporate 4000 kg of water per day. It is to be determined if this is a reasonable claim.

Assumptions 1 Water evaporates at an average temperature of 30°C . **2** The coefficient of performance of the air-conditioning unit is $\text{COP} = 3$.

Properties The enthalpy of vaporization of water at 30°C is 2429.8 kJ/kg (Table A-4).

Analysis Using the definition of COP, the electric power consumed by the air conditioning unit when running is

$$\dot{W}_{\text{in}} = \frac{\dot{Q}_{\text{cooling}}}{\text{COP}} = \frac{105 \text{ kW}}{3} = 35 \text{ kW}$$

Then the rate of heat rejected at the cooling tower becomes

$$\dot{Q}_{\text{rejected}} = \dot{Q}_{\text{cooling}} + \dot{W}_{\text{in}} = 105 + 35 = 140 \text{ kW}$$

Noting that 1 kg of water removes 2429.8 kJ of heat as it evaporates, the amount of water that needs to evaporate to remove heat at a rate of 140 kW is determined from $\dot{Q}_{\text{rejected}} = \dot{m}_{\text{water}} h_{fg}$ to be

$$\dot{m}_{\text{water}} = \frac{\dot{Q}_{\text{rejected}}}{h_{fg}} = \frac{140 \text{ kJ/s}}{2429.8 \text{ kJ/kg}} = 0.05762 \text{ kg/s} = 207.4 \text{ kg/h} = 4978 \text{ kg/day}$$

In practice, the air-conditioner will run intermittently rather than continuously at the rated power, and thus the water use will be less. Therefore, the claim amount of 4000 kg per day is **reasonable**.

14-118 Shading the condenser can reduce the air-conditioning costs by up to 10 percent. The amount of money shading can save a homeowner per year during its lifetime is to be determined.

Assumptions It is given that the annual air-conditioning cost is \$500 a year, and the life of the air-conditioning system is 20 years.

Analysis The amount of money that would be saved per year is determined directly from

$$(\$500/\text{year})(20 \text{ years})(0.10) = \mathbf{\$1000}$$

Therefore, the proposed measure will save about \$1000 during the lifetime of the system.

14-119E Wearing heavy long-sleeved sweaters and reducing the thermostat setting 1°F reduces the heating cost of a house by 4 percent at a particular location. The amount of money saved per year by lowering the thermostat setting by 4°F is to be determined.

Assumptions The household is willing to wear heavy long-sleeved sweaters in the house, and the annual heating cost is given to be \$600 a year.

Analysis The amount of money that would be saved per year is determined directly from

$$(\$600/\text{year})(0.04/^\circ\text{F})(4^\circ\text{F}) = \mathbf{\$96/\text{year}}$$

Therefore, the proposed measure will save the homeowner about \$100 during a heating season..

14-120 Air at a specified state is heated to to a specified temperature. The relative humidity after the heating is to be determined.

Assumptions 1 This is a steady-flow process and thus the mass flow rate of dry air remains constant during the entire process ($\dot{m}_{a1} = \dot{m}_{a2} = \dot{m}_a$). **2** Dry air and water vapor are ideal gases. **3** The kinetic and potential energy changes are negligible.

Analysis The properties of the air at the ambient state are determined from the psychrometric chart (Figure A-31) to be

$$\omega_1 = 0.0015 \text{ kg H}_2\text{O/kg dry air} (= \omega_2)$$

As the outside air infiltrates into the dacha, it does not gain or lose any water. Therefore the humidity ratio inside the dacha is the same as that outside,

$$\omega_2 = \omega_1 = 0.0015 \text{ kg H}_2\text{O/kg dry air}$$

Entering the psychrometry chart at this humidity ratio and the temperature inside the dacha gives

$$\phi_2 = 0.1184 \text{ or } \mathbf{11.8\%}$$

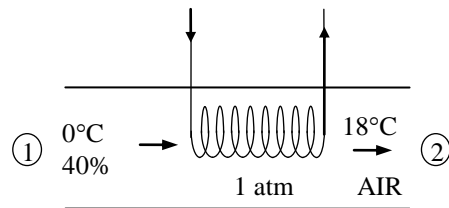

14-121 Air is humidified by evaporating water into this air. The amount of heating per m^3 of air is to be determined.

Assumptions **1** This is a steady-flow process and thus the mass flow rate of dry air remains constant during the entire process ($\dot{m}_{a1} = \dot{m}_{a2} = \dot{m}_a$). **2** Dry air and water vapor are ideal gases. **3** The kinetic and potential energy changes are negligible.

Properties The inlet and the exit states of the air are completely specified, and the total pressure is 1 atm. The properties of the air at various states are determined from the psychrometric chart (Figure A-31 or EES) to be

$$h_1 = 21.93 \text{ kJ/kg dry air}$$

$$\omega_1 = 0.001504 \text{ kg H}_2\text{O/kg dry air}$$

$$\nu_1 = 0.8268 \text{ m}^3/\text{kg dry air}$$

and

$$h_2 = 34.34 \text{ kJ/kg dry air}$$

$$\omega_2 = 0.006401 \text{ kg H}_2\text{O/kg dry air}$$

Also,

$$h_w \cong h_f @ 20^\circ\text{C} = 83.915 \text{ kJ/kg} \quad (\text{Table A-4})$$

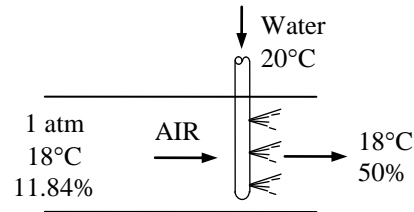

Analysis The amount of moisture in the air increases due to humidification ($\omega_2 > \omega_1$). Applying the water mass balance and energy balance equations to the combined cooling and humidification section,

Water Mass Balance:

$$\sum \dot{m}_{w,i} = \sum \dot{m}_{w,e} \longrightarrow \dot{m}_{a1}\omega_1 = \dot{m}_{a2}\omega_2 + \dot{m}_w$$

Energy Balance:

$$\dot{E}_{\text{in}} - \dot{E}_{\text{out}} = \Delta \dot{E}_{\text{system}} \stackrel{\text{0 (steady)}}{=} 0$$

$$\dot{E}_{\text{in}} = \dot{E}_{\text{out}}$$

$$\sum \dot{m}_i h_i + \dot{Q}_{\text{in}} = \sum \dot{m}_e h_e$$

$$\dot{Q}_{\text{in}} = \dot{m}_{a2}h_2 - \dot{m}_{a1}h_1 - \dot{m}_w h_w = \dot{m}_a (h_2 - h_1) - \dot{m}_w h_w$$

$$q_{\text{in}} = h_2 - h_1 - (\omega_2 - \omega_1)h_w$$

$$= (34.34 - 21.93) \text{ kJ/kg} - (0.006401 - 0.001504)(83.915)$$

$$= 12.00 \text{ kJ/kg dry air}$$

The heat transfer per unit volume is

$$Q_{\text{in}} = \frac{q_{\text{in}}}{\nu_1} = \frac{12.00 \text{ kJ/kg dry air}}{0.8268 \text{ m}^3/\text{kg dry air}} = \mathbf{14.5 \text{ kJ/m}^3}$$

14-122E Air is cooled by evaporating water into this air. The amount of water required and the cooling produced are to be determined.

Assumptions **1** This is a steady-flow process and thus the mass flow rate of dry air remains constant during the entire process ($\dot{m}_{a1} = \dot{m}_{a2} = \dot{m}_a$). **2** Dry air and water vapor are ideal gases. **3** The kinetic and potential energy changes are negligible.

Properties The inlet and the exit states of the air are completely specified, and the total pressure is 1 atm. The properties of the air at various states are determined from the psychrometric chart (Figure A-31E) to be

$$h_1 = 35.6 \text{ Btu/lbm dry air}$$

$$\omega_1 = 0.0082 \text{ lbm H}_2\text{O/lbm dry air}$$

and

$$h_2 = 34.3 \text{ Btu/lbm dry air}$$

$$\omega_2 = 0.0149 \text{ lbm H}_2\text{O/lbm dry air}$$

Also,

$$h_w \cong h_f @ 70^\circ\text{F} = 38.08 \text{ Btu/lbm} \quad (\text{Table A-4E})$$

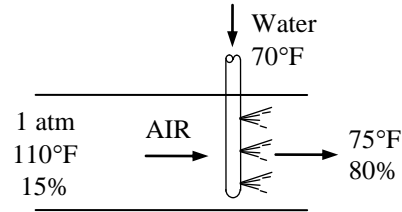

Analysis The amount of moisture in the air increases due to humidification ($\omega_2 > \omega_1$). Applying the water mass balance and energy balance equations to the combined cooling and humidification section,

Water Mass Balance:

$$\sum \dot{m}_{w,i} = \sum \dot{m}_{w,e} \longrightarrow \dot{m}_{a1}\omega_1 = \dot{m}_{a2}\omega_2 + \dot{m}_w$$

$$\Delta\omega = \omega_2 - \omega_1 = 0.0149 - 0.0082 = \mathbf{0.0067 \text{ lbm H}_2\text{O/klbm dry air}}$$

Energy Balance:

$$\dot{E}_{\text{in}} - \dot{E}_{\text{out}} = \Delta\dot{E}_{\text{system}} \overset{\phi^0(\text{steady})}{=} 0$$

$$\dot{E}_{\text{in}} = \dot{E}_{\text{out}}$$

$$\sum \dot{m}_i h_i = \dot{Q}_{\text{out}} + \sum \dot{m}_e h_e$$

$$\dot{Q}_{\text{out}} = \dot{m}_a h_1 + \dot{m}_w h_w - \dot{m}_a h_2 = \dot{m}_a (h_1 - h_2) + \dot{m}_w h_w$$

$$q_{\text{out}} = h_1 - h_2 + (\omega_2 - \omega_1)h_w$$

$$= (35.6 - 34.3)\text{Btu/lbm} + (0.0067)(38.08)$$

$$= \mathbf{1.47 \text{ Btu/lbm dry air}}$$

14-123E Air is humidified adiabatically by evaporating water into this air. The temperature of the air at the exit is to be determined.

Assumptions **1** This is a steady-flow process and thus the mass flow rate of dry air remains constant during the entire process ($\dot{m}_{a1} = \dot{m}_{a2} = \dot{m}_a$). **2** Dry air and water vapor are ideal gases. **3** The kinetic and potential energy changes are negligible.

Properties The inlet state of the air is completely specified, and the total pressure is 1 atm. The properties of the air at the inlet state are determined from the psychrometric chart (Figure A-31E) to be

$$h_1 = 35.6 \text{ Btu/lbmdry air}$$

$$\omega_1 = 0.0082 \text{ lbm H}_2\text{O/lbm dry air}$$

and $h_w \cong h_f @ 70^\circ\text{F} = 38.08 \text{ Btu/lbm}$ (Table A-4E)

Analysis The amount of moisture in the air increases due to humidification ($\omega_2 > \omega_1$). Applying the water mass balance and energy balance equations to the combined cooling and humidification section,

Water Mass Balance:

$$\begin{aligned} \sum \dot{m}_{w,i} &= \sum \dot{m}_{w,e} \longrightarrow \dot{m}_{a1}\omega_1 = \dot{m}_{a2}\omega_2 + \dot{m}_w \\ \dot{m}_w &= \dot{m}_a(\omega_2 - \omega_1) \end{aligned}$$

Energy Balance:

$$\begin{aligned} \dot{E}_{in} - \dot{E}_{out} &= \Delta \dot{E}_{system} \stackrel{\text{0 (steady)}}{=} 0 \\ \dot{E}_{in} &= \dot{E}_{out} \\ \sum \dot{m}_i h_i &= \sum \dot{m}_e h_e \\ \dot{m}_{a1}h_1 + \dot{m}_w h_w &= \dot{m}_{a2}h_2 \\ \dot{m}_w h_w &= \dot{m}_a(h_2 - h_1) \\ (\omega_2 - \omega_1)h_w &= h_2 - h_1 \end{aligned}$$

Substituting,

$$(\omega_2 - 0.0092)(83.92) = h_2 - 64.0$$

The solution of this equation requires a trial-error method. An air exit temperature is assumed. At this temperature and the given relative humidity, the enthalpy and specific humidity values are obtained from psychrometric chart and substituted into this equation. If the equation is not satisfied, a new value of exit temperature is assumed and this continues until the equation is satisfied. Alternatively, an equation solver such as EES may be used for the direct results. We used the following EES program to get these results:

$$T_2 = \mathbf{79.6^\circ\text{F}}$$

$$h_2 = 35.8 \text{ Btu/lbmdry air}$$

$$\omega_2 = 0.0152 \text{ lbm H}_2\text{O/lbm dry air}$$

"Given"

$$P=14.696 \text{ [psia]}$$

$$T_1=110 \text{ [F]}$$

$$\text{phi}_1=0.15$$

$$\text{phi}_2=0.70$$

$$T_w=70 \text{ [F]}$$

"Analysis"

$$\text{Fluid1\$}=\text{'AirH2O'}$$

$$\text{Fluid2\$}=\text{'steam_iapws'}$$

$$h_1=\text{enthalpy}(\text{Fluid1\$}, T=T_1, R=\text{phi}_1, P=P)$$

$$w_1=\text{humrat}(\text{Fluid1\$}, T=T_1, R=\text{phi}_1, P=P)$$

$$h_2=\text{enthalpy}(\text{Fluid1\$}, T=T_2, R=\text{phi}_2, P=P)$$

$$w_2=\text{humrat}(\text{Fluid1\$}, T=T_2, R=\text{phi}_2, P=P)$$

$$h_w=\text{enthalpy}(\text{Fluid2\$}, T=T_w, x=0)$$

$$q=0$$

$$q=h_1-h_2+(w_2-w_1)*h_w$$

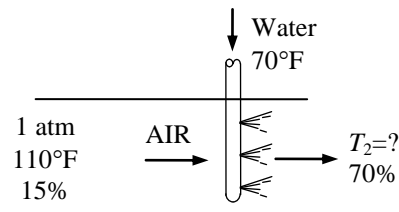

14-124 A tank contains saturated air at a specified state. The mass of the dry air, the specific humidity, and the enthalpy of the air are to be determined.

Assumptions The air and the water vapor are ideal gases.

Analysis (a) The air is saturated, thus the partial pressure of water vapor is equal to the saturation pressure at the given temperature,

$$P_v = P_g = P_{\text{sat @ } 20^\circ\text{C}} = 2.339 \text{ kPa}$$

$$P_a = P - P_v = 90 - 2.339 = 87.66 \text{ kPa}$$

Treating air as an ideal gas,

$$m_a = \frac{P_a V}{R_a T} = \frac{(87.66 \text{ kPa})(1.8 \text{ m}^3)}{(0.287 \text{ kPa} \cdot \text{m}^3 / \text{kg} \cdot \text{K})(293 \text{ K})} = \mathbf{1.88 \text{ kg}}$$

<p>1.8 m³ 20°C 90 kPa</p>
--

(b) The specific humidity of air is determined from

$$\omega = \frac{0.622 P_v}{P - P_v} = \frac{(0.622)(2.339 \text{ kPa})}{(90 - 2.339) \text{ kPa}} = \mathbf{0.0166 \text{ kg H}_2\text{O/kg dry air}}$$

(c) The enthalpy of air per unit mass of dry air is determined from

$$\begin{aligned} h &= h_a + \omega h_v \cong c_p T + \omega h_g \\ &= (1.005 \text{ kJ/kg} \cdot ^\circ\text{C})(20^\circ\text{C}) + (0.0166)(2537.4 \text{ kJ/kg}) \\ &= \mathbf{62.2 \text{ kJ/kg dry air}} \end{aligned}$$



14-125 Problem 14-124 is reconsidered. The properties of the air at the initial state are to be determined and the effects of heating the air at constant volume until the pressure is 110 kPa is to be studied.

Analysis The problem is solved using EES, and the solution is given below.

"Input Data:"

Tdb[1] = 20 [C]
 P[1]=90 [kPa]
 Rh[1]=1.0
 P[2]=110 [kPa]
 Vol = 1.8 [m^3]

w[1]=HUMRAT(AirH2O,T=Tdb[1],P=P[1],R=Rh[1])
 v[1]=VOLUME(AirH2O,T=Tdb[1],P=P[1],R=Rh[1])
 m_a=Vol/v[1]
 h[1]=ENTHALPY(AirH2O,T=Tdb[1],P=P[1],w=w[1])

"Energy Balance for the constant volume tank:"

E_in - E_out = DELTAE_tank
 DELTAE_tank=m_a*(u[2]-u[1])
 E_in = Q_in
 E_out = 0 [kJ]
 u[1]=INTENERGY(AirH2O,T=Tdb[1],P=P[1],w=w[1])
 u[2]=INTENERGY(AirH2O,T=Tdb[2],P=P[2],w=w[2])

"The ideal gas mixture assumption applied to the constant volume process yields:"

$P[1]/(Tdb[1]+273)=P[2]/(Tdb[2]+273)$

"The mass of the water vapor and dry air are constant, thus:"

w[2]=w[1]
 Rh[2]=RELHUM(AirH2O,T=Tdb[2],P=P[2],w=w[2])
 h[2]=ENTHALPY(AirH2O,T=Tdb[2],P=P[2],w=w[2])
 v[2]=VOLUME(AirH2O,T=Tdb[2],P=P[2],R=Rh[2])

PROPERTIES AT THE INITIAL STATE

h[1]=62.25 [kJ/kg]
 m_a=1.875 [kga]
 v[1]=0.9599 [m^3/kga]
 w[1]=0.01659 [kgw/kga]

P ₂ [kPa]	Q _{in} [kJ]
90	0
92	9.071
94	18.14
96	27.22
98	36.29
100	45.37
102	54.44
104	63.52
106	72.61
108	81.69
110	90.78

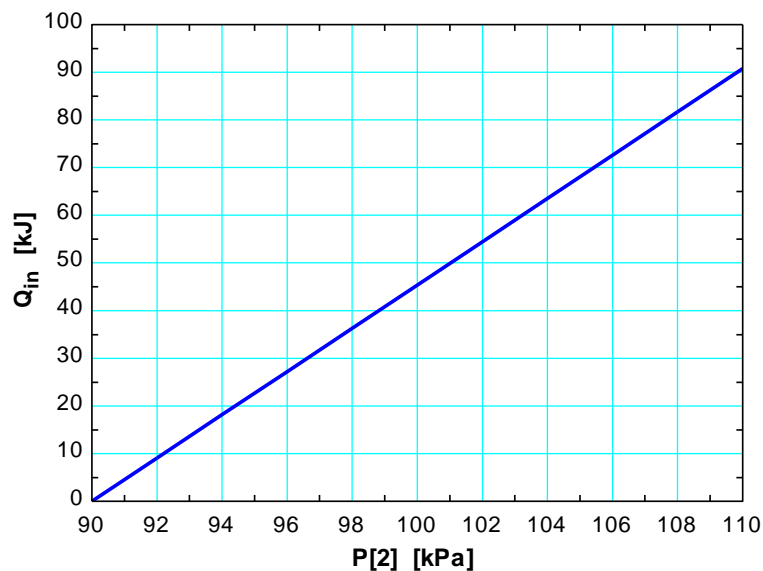

14-126E Air at a specified state and relative humidity flows through a circular duct. The dew-point temperature, the volume flow rate of air, and the mass flow rate of dry air are to be determined.

Assumptions The air and the water vapor are ideal gases.

Analysis (a) The vapor pressure of air is

$$P_v = \phi P_g = \phi P_{\text{sat}@60^\circ\text{F}} = (0.70)(0.2564 \text{ psia}) = 0.1795 \text{ psia}$$

Thus the dew-point temperature of the air is

$$T_{\text{dp}} = T_{\text{sat}@P_v} = T_{\text{sat}@0.1795 \text{ psia}} = \mathbf{50.2^\circ\text{F}} \quad (\text{from EES})$$

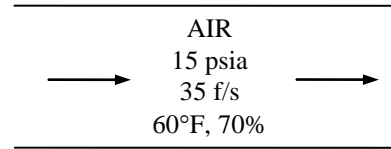

(b) The volume flow rate is determined from

$$\dot{V} = VA = V \frac{\pi D^2}{4} = (35 \text{ ft/s}) \left(\frac{\pi \times (6/12 \text{ ft})^2}{4} \right) = \mathbf{6.872 \text{ ft}^3/\text{s}}$$

(c) To determine the mass flow rate of dry air, we first need to calculate its specific volume,

$$P_a = P - P_v = 15 - 0.1795 = 14.82 \text{ psia}$$

$$\nu_1 = \frac{R_a T_1}{P_{a1}} = \frac{(0.3704 \text{ psia} \cdot \text{ft}^3 / \text{lbm} \cdot \text{R})(520 \text{ R})}{14.82 \text{ psia}} = 13.00 \text{ ft}^3 / \text{lbm dry air}$$

Thus,

$$\dot{m}_{a1} = \frac{\dot{V}_1}{\nu_1} = \frac{6.872 \text{ ft}^3 / \text{s}}{13.00 \text{ ft}^3 / \text{lbm dry air}} = \mathbf{0.529 \text{ lbm/s}}$$

14-127 Air flows steadily through an isentropic nozzle. The pressure, temperature, and velocity of the air at the nozzle exit are to be determined.

Assumptions **1** This is a steady-flow process and thus the mass flow rate of dry air remains constant during the entire process ($\dot{m}_{a1} = \dot{m}_{a2} = \dot{m}_a$). **2** Dry air and water vapor are ideal gases. **3** The kinetic and potential energy changes are negligible.

Analysis The inlet state of the air is completely specified, and the total pressure is 200 kPa. The properties of the air at the inlet state may be determined from the psychrometric chart (Figure A-31) or using EES psychrometric functions to be (we used EES)

$$h_1 = 57.65 \text{ kJ/kg dry air}$$

$$\omega_1 = \omega_2 = 0.008803 \text{ kg H}_2\text{O/kg dry air} \quad (\text{no condensation})$$

$$s_1 = s_2 = 5.613 \text{ kJ/kg}\cdot\text{K dry air} \quad (\text{isentropic process})$$

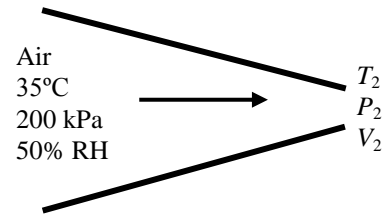

We assume that the relative humidity at the nozzle exit is 100 percent since there is no condensation in the nozzle. Other exit state properties can be determined using EES built-in functions for moist air. The results are

$$h_2 = 42.53 \text{ kJ/kg dry air}$$

$$P_2 = \mathbf{168.2 \text{ kPa}}$$

$$T_2 = \mathbf{20^\circ\text{C}}$$

An energy balance on the control volume gives the velocity at the exit

$$h_1 = h_2 + (1 + \omega_2) \frac{V_2^2}{2}$$

$$57.65 \text{ kJ/kg} = 42.53 \text{ kJ/kg} + (1 + 0.008803) \frac{V_2^2}{2} \left(\frac{1 \text{ kJ/kg}}{1000 \text{ m}^2/\text{s}^2} \right)$$

$$V_2 = \mathbf{173.2 \text{ m/s}}$$

14-128 Air enters a cooling section at a specified pressure, temperature, and relative humidity. The temperature of the air at the exit and the rate of heat transfer are to be determined.

Assumptions 1 This is a steady-flow process and thus the mass flow rate of dry air remains constant during the entire process ($\dot{m}_{a1} = \dot{m}_{a2} = \dot{m}_a$). **2** Dry air and water vapor are ideal gases. **3** The kinetic and potential energy changes are negligible.

Analysis (a) The amount of moisture in the air also remains constant ($\omega_1 = \omega_2$) as it flows through the cooling section since the process involves no humidification or dehumidification. The total pressure is 97 kPa. The properties of the air at the inlet state are

$$P_{v1} = \phi_1 P_{g1} = \phi_1 P_{\text{sat}@35^\circ\text{C}} = (0.3)(5.629 \text{ kPa}) = 1.69 \text{ kPa}$$

$$P_{a1} = P_1 - P_{v1} = 97 - 1.69 = 95.31 \text{ kPa}$$

$$\begin{aligned} \nu_1 &= \frac{R_a T_1}{P_{a1}} = \frac{(0.287 \text{ kPa} \cdot \text{m}^3 / \text{kg} \cdot \text{K})(308 \text{ K})}{95.31 \text{ kPa}} \\ &= 0.927 \text{ m}^3 / \text{kg dry air} \end{aligned}$$

$$\omega_1 = \frac{0.622 P_{v1}}{P_1 - P_{v1}} = \frac{0.622(1.69 \text{ kPa})}{(97 - 1.69) \text{ kPa}} = 0.0110 \text{ kg H}_2\text{O/kg dry air} (= \omega_2)$$

$$h_1 = c_p T_1 + \omega_1 h_{g1} = (1.005 \text{ kJ/kg} \cdot ^\circ\text{C})(35^\circ\text{C}) + (0.0110)(2564.6 \text{ kJ/kg}) = 63.44 \text{ kJ/kg dry air}$$

The air at the final state is saturated and the vapor pressure during this process remains constant. Therefore, the exit temperature of the air must be the dew-point temperature,

$$T_{\text{dp}} = T_{\text{sat}@P_v} = T_{\text{sat}@1.69 \text{ kPa}} = \mathbf{14.8^\circ\text{C}}$$

(b) The enthalpy of the air at the exit is

$$h_2 = c_p T_2 + \omega_2 h_{g2} = (1.005 \text{ kJ/kg} \cdot ^\circ\text{C})(14.8^\circ\text{C}) + (0.0110)(2528.1 \text{ kJ/kg}) = 42.78 \text{ kJ/kg dry air}$$

Also

$$\dot{m}_a = \frac{\dot{V}_1}{\nu_1} = \frac{6 \text{ m}^3 / \text{s}}{0.927 \text{ m}^3 / \text{kg dry air}} = 6.47 \text{ kg/min}$$

Then the rate of heat transfer from the air in the cooling section becomes

$$\dot{Q}_{\text{out}} = \dot{m}_a (h_1 - h_2) = (6.47 \text{ kg/min})(63.44 - 42.78) \text{ kJ/kg} = \mathbf{134 \text{ kJ/min}}$$

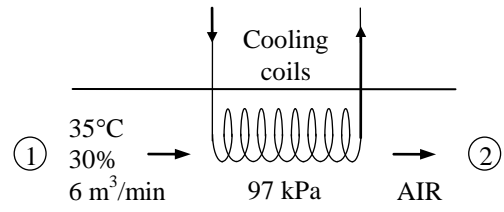

14-129 The outdoor air is first heated and then humidified by hot steam in an air-conditioning system. The rate of heat supply in the heating section and the mass flow rate of the steam required in the humidifying section are to be determined.

Assumptions 1 This is a steady-flow process and thus the mass flow rate of dry air remains constant during the entire process ($\dot{m}_{a1} = \dot{m}_{a2} = \dot{m}_a$). **2** Dry air and water vapor are ideal gases. **3** The kinetic and potential energy changes are negligible.

Properties The amount of moisture in the air also remains constant as it flows through the heating section ($\omega_1 = \omega_2$), but increases in the humidifying section ($\omega_3 > \omega_2$). The inlet and the exit states of the air are completely specified, and the total pressure is 1 atm. The properties of the air at various states are determined from the psychrometric chart (Fig. A-31) to be

$$\begin{aligned} h_1 &= 23.47 \text{ kJ/kg dry air} \\ \omega_1 &= 0.005322 \text{ kg H}_2\text{O/kg dry air} (= \omega_2) \\ \nu_1 &= 0.8090 \text{ m}^3/\text{kg dry air} \\ h_2 &= 31.60 \text{ kJ/kg dry air} \\ \omega_2 &= \omega_1 = 0.005322 \text{ kg H}_2\text{O/kg dry air} \\ h_3 &= 52.90 \text{ kJ/kg dry air} \\ \omega_3 &= 0.01089 \text{ kg H}_2\text{O/kg dry air} \end{aligned}$$

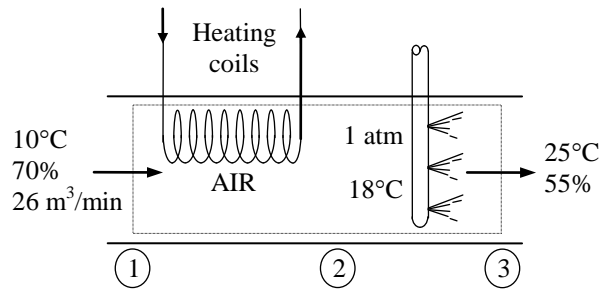

Analysis (a) The mass flow rate of dry air is

$$\dot{m}_a = \frac{\dot{V}_1}{\nu_1} = \frac{26 \text{ m}^3/\text{min}}{0.8090 \text{ m}^3/\text{kg}} = 32.14 \text{ kg/min}$$

Then the rate of heat transfer to the air in the heating section becomes

$$\dot{Q}_{\text{in}} = \dot{m}_a (h_2 - h_1) = (32.14 \text{ kg/min})(31.60 - 23.47) \text{ kJ/kg} = \mathbf{261 \text{ kJ/min}}$$

(b) The conservation of mass equation for water in the humidifying section can be expressed as

$$\dot{m}_{a2}\omega_2 + \dot{m}_w = \dot{m}_{a3}\omega_3 \quad \text{or} \quad \dot{m}_w = \dot{m}_a(\omega_3 - \omega_2)$$

Thus,

$$\dot{m}_w = (32.14 \text{ kg/min})(0.01089 - 0.005322) = \mathbf{0.179 \text{ kg/min}}$$

14-130 Air is cooled and dehumidified at constant pressure. The system hardware and the psychrometric diagram are to be sketched and the heat transfer is to be determined.

Assumptions 1 This is a steady-flow process and thus the mass flow rate of dry air remains constant during the entire process ($\dot{m}_{a1} = \dot{m}_{a2} = \dot{m}_a$). **2** Dry air and water vapor are ideal gases. **3** The kinetic and potential energy changes are negligible.

Properties (a) The schematic of the cooling and dehumidification process and the process on the psychrometric chart are given below. The psychrometric chart is obtained from the Property Plot feature of EES.

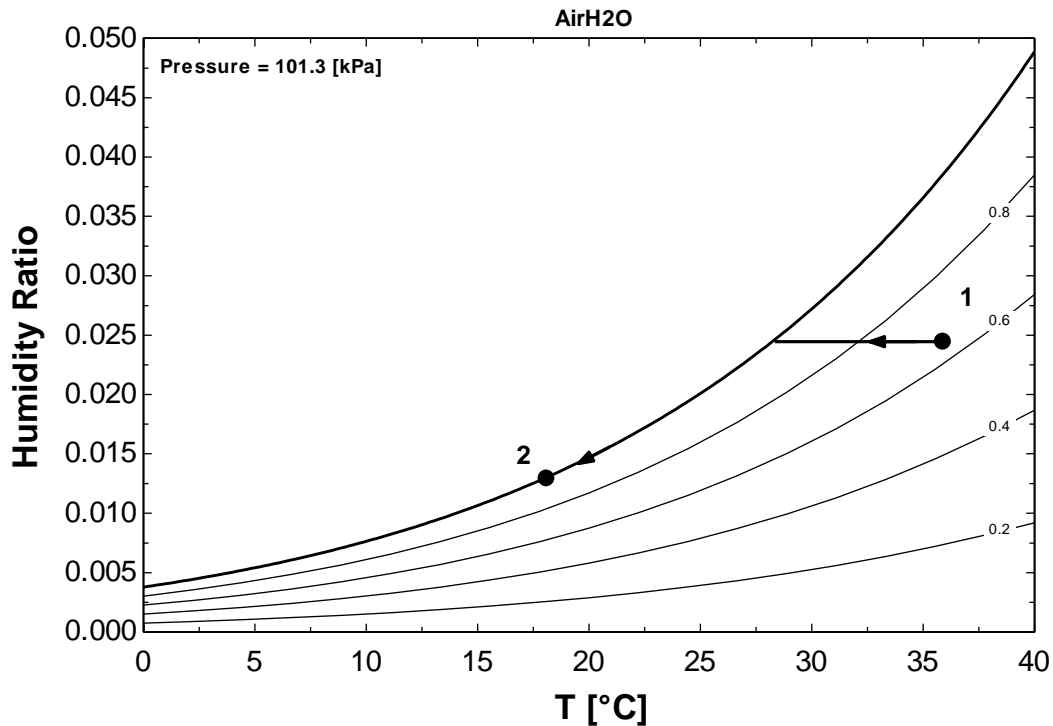

(b) The inlet and the exit states of the air are completely specified, and the total pressure is 101.3 kPa (1 atm). The properties of the air at the inlet and exit states are determined from the psychrometric chart (Figure A-31 or EES, we used EES.) to be

$$T_{dp} = 28.37^\circ\text{C}$$

$$h_1 = 99.60 \text{ kJ/kg dry air}$$

$$\omega_1 = 0.02467 \text{ kg H}_2\text{O/kg dry air}$$

and

$$T_2 = T_{dp} - 10 = 28.37 - 10 = 18.37^\circ\text{C}$$

$$\phi_2 = 1.0$$

$$h_2 = 52.09 \text{ kJ/kg dry air}$$

$$\omega_2 = 0.01324 \text{ kg H}_2\text{O/kg dry air}$$

Also,

$$h_w \cong h_f @ 18.37^\circ\text{C} = 77.11 \text{ kJ/kg} \quad (\text{Table A-4})$$

Analysis Applying the water mass balance and energy balance equations to the combined cooling and dehumidification section,

Water Mass Balance:

$$\sum \dot{m}_{w,i} = \sum \dot{m}_{w,e} \longrightarrow \dot{m}_{a1}\omega_1 = \dot{m}_{a2}\omega_2 + \dot{m}_w$$

$$\dot{m}_w = \dot{m}_a(\omega_1 - \omega_2)$$

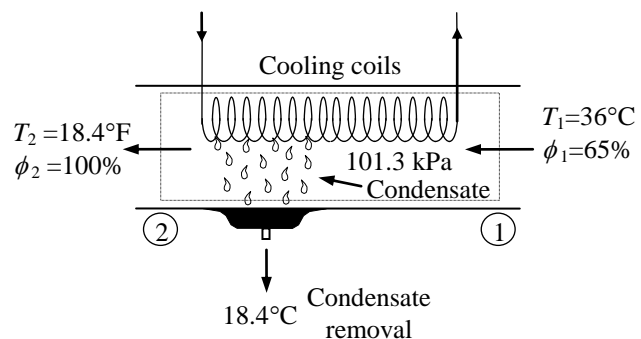

Energy Balance:

$$\begin{aligned}\dot{E}_{\text{in}} - \dot{E}_{\text{out}} &= \Delta \dot{E}_{\text{system}} \stackrel{\phi^0(\text{steady})}{=} 0 \\ \dot{E}_{\text{in}} &= \dot{E}_{\text{out}} \\ \sum \dot{m}_i h_i &= \dot{Q}_{\text{out}} + \sum \dot{m}_e h_e \\ \dot{Q}_{\text{out}} &= \dot{m}_{a1} h_1 - (\dot{m}_{a2} h_2 + \dot{m}_w h_w) \\ &= \dot{m}_a (h_1 - h_2) - \dot{m}_w h_w \\ &= \dot{m}_a (h_1 - h_2) - \dot{m}_a (\omega_1 - \omega_2) h_w\end{aligned}$$

Dividing by \dot{m}_a

$$q_{\text{out}} = (h_1 - h_2) - (\omega_1 - \omega_2) h_w$$

Substituting,

$$q_{\text{out}} = (h_1 - h_2) - (\omega_1 - \omega_2) h_w = (99.60 - 52.09) \text{ kJ/kg} - (0.02467 - 0.01324)(77.11 \text{ kJ/kg}) = \mathbf{46.6 \text{ kJ/kg}}$$

14-131 Air is cooled and dehumidified in an air-conditioning system with refrigerant-134a as the working fluid. The rate of dehumidification, the rate of heat transfer, and the mass flow rate of the refrigerant are to be determined.

Assumptions 1 This is a steady-flow process and thus the mass flow rate of dry air remains constant during the entire process ($\dot{m}_{a1} = \dot{m}_{a2} = \dot{m}_a$). **2** Dry air and water vapor are ideal gases. **3** The kinetic and potential energy changes are negligible.

Analysis (a) The saturation pressure of water at 30°C is 4.2469 kPa. Then the dew point temperature of the incoming air stream at 30°C becomes

$$T_{dp} = T_{sat @ P_v} = T_{sat @ 0.7 \times 4.2469 \text{ kPa}} = 24^\circ\text{C}$$

Since air is cooled to 20°C, which is below its dew point temperature, some of the moisture in the air will condense.

The mass flow rate of dry air remains constant during the entire process, but the amount of moisture in the air decreases due to dehumidification ($\omega_2 < \omega_1$). The inlet and the exit states of the air are completely specified, and the total pressure is 1 atm. Then the properties of the air at both states are determined from the psychrometric chart (Fig. A-31) to be

$$h_1 = 78.3 \text{ kJ/kg dry air}$$

$$\omega_1 = 0.0188 \text{ kg H}_2\text{O/kg dry air}$$

$$\nu_1 = 0.885 \text{ m}^3/\text{kg dry air}$$

and

$$h_2 = 57.5 \text{ kJ/kg dry air}$$

$$\omega_2 = 0.0147 \text{ kg H}_2\text{O/kg dry air}$$

Also, $h_w \cong h_f @ 20^\circ\text{C} = 83.915 \text{ kJ/kg}$ (Table A-4)

$$\text{Then, } \dot{m}_{a1} = \frac{\dot{V}_1}{\nu_1} = \frac{4 \text{ m}^3/\text{min}}{0.885 \text{ m}^3/\text{kg dry air}} = 4.52 \text{ kg/min}$$

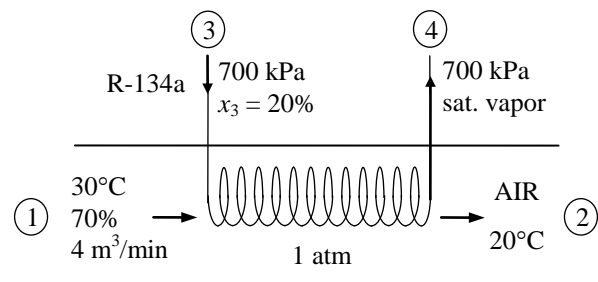

Applying the water mass balance and the energy balance equations to the combined cooling and dehumidification section (excluding the refrigerant),

Water Mass Balance:

$$\sum \dot{m}_{w,i} = \sum \dot{m}_{w,e} \quad \longrightarrow \quad \dot{m}_{a1}\omega_1 = \dot{m}_{a2}\omega_2 + \dot{m}_w$$

$$\dot{m}_w = \dot{m}_a(\omega_1 - \omega_2) = (4.52 \text{ kg/min})(0.0188 - 0.0147) = \mathbf{0.0185 \text{ kg/min}}$$

(b) Energy Balance:

$$\dot{E}_{in} - \dot{E}_{out} = \Delta \dot{E}_{system} \stackrel{\text{no (steady)}}{=} 0$$

$$\dot{E}_{in} = \dot{E}_{out}$$

$$\sum \dot{m}_i h_i = \dot{Q}_{out} + \sum \dot{m}_e h_e \quad \longrightarrow \quad \dot{Q}_{out} = \dot{m}_{a1}h_1 - (\dot{m}_{a2}h_2 + \dot{m}_w h_w) = \dot{m}_a(h_1 - h_2) - \dot{m}_w h_w$$

$$\dot{Q}_{out} = (4.52 \text{ kg/min})(78.3 - 57.5) \text{ kJ/kg} - (0.0185 \text{ kg/min})(83.915 \text{ kJ/kg}) = \mathbf{92.5 \text{ kJ/min}}$$

(c) The inlet and exit enthalpies of the refrigerant are

$$h_3 = h_g + x_3 h_{fg} = 88.82 + 0.2 \times 176.21 = 124.06 \text{ kJ/kg}$$

$$h_4 = h_g @ 700 \text{ kPa} = 265.03 \text{ kJ/kg}$$

Noting that the heat lost by the air is gained by the refrigerant, the mass flow rate of the refrigerant becomes

$$\dot{Q}_R = \dot{m}_R(h_4 - h_3) \quad \longrightarrow \quad \dot{m}_R = \frac{\dot{Q}_R}{h_4 - h_3} = \frac{92.5 \text{ kJ/min}}{(265.03 - 124.06) \text{ kJ/kg}} = \mathbf{0.66 \text{ kg/min}}$$

14-132 Air is cooled and dehumidified in an air-conditioning system with refrigerant-134a as the working fluid. The rate of dehumidification, the rate of heat transfer, and the mass flow rate of the refrigerant are to be determined.

Assumptions 1 This is a steady-flow process and thus the mass flow rate of dry air remains constant during the entire process. **2** Dry air and water vapor are ideal gases. **3** The kinetic and potential energy changes are negligible.

Analysis (a) The dew point temperature of the incoming air stream at 30°C is

$$P_{v1} = \phi_1 P_{g1} = \phi_1 P_{\text{sat}@30^\circ\text{C}} = (0.7)(4.247 \text{ kPa}) = 2.973 \text{ kPa}$$

$$T_{\text{dp}} = T_{\text{sat}@P_v} = T_{\text{sat}@2.973 \text{ kPa}} = 23.9^\circ\text{C}$$

Since air is cooled to 20°C, which is below its dew point temperature, some of the moisture in the air will condense.

The amount of moisture in the air decreases due to dehumidification ($\omega_2 < \omega_1$). The inlet and the exit states of the air are completely specified, and the total pressure is 95 kPa. The properties of the air at both states are determined to be

$$P_{a1} = P_1 - P_{v1} = 90 - 2.973 = 87.03 \text{ kPa}$$

$$\nu_1 = \frac{R_a T_1}{P_{a1}} = \frac{(0.287 \text{ kPa} \cdot \text{m}^3 / \text{kg} \cdot \text{K})(303 \text{ K})}{87.03 \text{ kPa}} = 0.9992 \text{ m}^3 / \text{kg dry air}$$

$$\omega_1 = \frac{0.622 P_{v1}}{P_1 - P_{v1}} = \frac{0.622(2.973 \text{ kPa})}{(90 - 2.973) \text{ kPa}} = 0.02125 \text{ kg H}_2\text{O/kg dry air}$$

$$h_1 = c_p T_1 + \omega_1 h_{g1} = (1.005 \text{ kJ/kg} \cdot ^\circ\text{C})(30^\circ\text{C}) + (0.02125)(2555.6 \text{ kJ/kg}) = 84.45 \text{ kJ/kg dry air}$$

and

$$P_{v2} = \phi_2 P_{g2} = (1.00)P_{\text{sat}@20^\circ\text{C}} = 2.3392 \text{ kPa}$$

$$\omega_2 = \frac{0.622 P_{v2}}{P_2 - P_{v2}} = \frac{0.622(2.3392 \text{ kPa})}{(95 - 2.3392) \text{ kPa}} = 0.01660 \text{ kg H}_2\text{O/kg dry air}$$

$$h_2 = c_p T_2 + \omega_2 h_{g2} = (1.005 \text{ kJ/kg} \cdot ^\circ\text{C})(20^\circ\text{C}) + (0.01660)(2537.4 \text{ kJ/kg}) = 62.22 \text{ kJ/kg dry air}$$

Also, $h_w \cong h_f @ 20^\circ\text{C} = 83.915 \text{ kJ/kg}$ (Table A-4)

Then, $\dot{m}_{a1} = \frac{\dot{V}_1}{\nu_1} = \frac{4 \text{ m}^3 / \text{min}}{0.9992 \text{ m}^3 / \text{kg dry air}} = 4.003 \text{ kg/min}$

Applying the water mass balance and the energy balance equations to the combined cooling and dehumidification section (excluding the refrigerant),

Water Mass Balance: $\sum \dot{m}_{w,i} = \sum \dot{m}_{w,e} \longrightarrow \dot{m}_{a1}\omega_1 = \dot{m}_{a2}\omega_2 + \dot{m}_w$

$$\dot{m}_w = \dot{m}_a(\omega_1 - \omega_2) = (4.003 \text{ kg/min})(0.02125 - 0.01660) = \mathbf{0.01861 \text{ kg/min}}$$

(b) **Energy Balance:**

$$\dot{E}_{\text{in}} - \dot{E}_{\text{out}} = \Delta \dot{E}_{\text{system}} \stackrel{\approx 0 \text{ (steady)}}{=} 0$$

$$\dot{E}_{\text{in}} = \dot{E}_{\text{out}}$$

$$\sum \dot{m}_i h_i = \dot{Q}_{\text{out}} + \sum \dot{m}_e h_e \longrightarrow \dot{Q}_{\text{out}} = \dot{m}_{a1} h_1 - (\dot{m}_{a2} h_2 + \dot{m}_w h_w) = \dot{m}_a (h_1 - h_2) - \dot{m}_w h_w$$

$$\dot{Q}_{\text{out}} = (4.003 \text{ kg/min})(84.45 - 62.22) \text{ kJ/kg} - (0.01861 \text{ kg/min})(83.915 \text{ kJ/kg}) = \mathbf{87.44 \text{ kJ/min}}$$

(c) The inlet and exit enthalpies of the refrigerant are

$$h_3 = h_g + x_3 h_{fg} = 88.82 + 0.2 \times 176.26 = 124.07 \text{ kJ/kg}$$

$$h_4 = h_g @ 700 \text{ kPa} = 265.08 \text{ kJ/kg}$$

Noting that the heat lost by the air is gained by the refrigerant, the mass flow rate of the refrigerant is determined from

$$\dot{Q}_R = \dot{m}_R (h_4 - h_3)$$

$$\dot{m}_R = \frac{\dot{Q}_R}{h_4 - h_3} = \frac{87.44 \text{ kJ/min}}{(265.08 - 124.07) \text{ kJ/kg}} = \mathbf{0.620 \text{ kg/min}}$$

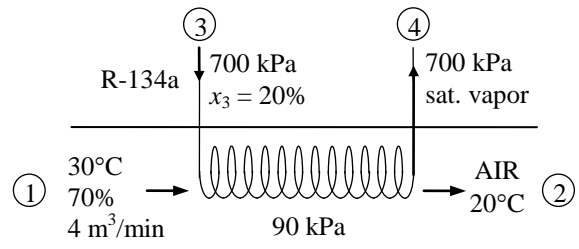

14-133 Air is heated and dehumidified in an air-conditioning system consisting of a heating section and an evaporative cooler. The temperature and relative humidity of the air when it leaves the heating section, the rate of heat transfer in the heating section, and the rate of water added to the air in the evaporative cooler are to be determined.

Assumptions 1 This is a steady-flow process and thus the mass flow rate of dry air remains constant during the entire process ($\dot{m}_{a1} = \dot{m}_{a2} = \dot{m}_a$). 2 Dry air and water vapor are ideal gases. 3 The kinetic and potential energy changes are negligible.

Analysis (a) Assuming the wet-bulb temperature of the air remains constant during the evaporative cooling process, the properties of air at various states are determined from the psychrometric chart (Fig. A-31 or EES) to be

$$\begin{aligned}
 \left. \begin{array}{l} T_1 = 15^\circ\text{C} \\ \phi_1 = 55\% \end{array} \right\} & \begin{array}{l} h_1 = 29.8 \text{ kJ/kg dry air} \\ \omega_1 = 0.00581 \text{ kg/H}_2\text{O/kg dry air} \\ \nu_1 = 0.824 \text{ m}^3/\text{kg} \end{array} \\
 \left. \begin{array}{l} \omega_2 = \omega_1 \\ T_{wb2} = T_{wb3} \end{array} \right\} & \begin{array}{l} T_2 = 32.5^\circ\text{C} \\ \phi_2 = 19.2\% \\ h_2 \cong h_3 = 47.8 \text{ kJ/kg dry air} \end{array} \\
 \left. \begin{array}{l} T_3 = 25^\circ\text{C} \\ \phi_3 = 45\% \end{array} \right\} & \begin{array}{l} h_3 = 47.8 \text{ kJ/kg dry air} \\ \omega_3 = 0.00888 \text{ kg/H}_2\text{O/kg dry air} \\ T_{wb3} = 17.1^\circ\text{C} \end{array}
 \end{aligned}$$

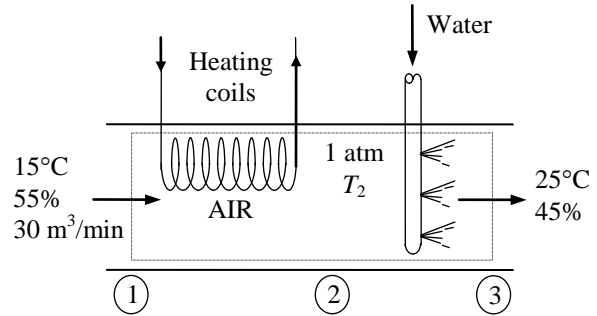

(b) The mass flow rate of dry air is

$$\dot{m}_a = \frac{\dot{V}_1}{\nu_1} = \frac{30 \text{ m}^3/\text{min}}{0.824 \text{ m}^3/\text{kg dry air}} = 36.4 \text{ kg/min}$$

Then the rate of heat transfer to air in the heating section becomes

$$\dot{Q}_{in} = \dot{m}_a (h_2 - h_1) = (36.4 \text{ kg/min})(47.8 - 29.8) \text{ kJ/kg} = \mathbf{655 \text{ kJ/min}}$$

(c) The rate of water added to the air in evaporative cooler is

$$\dot{m}_{w, \text{ added}} = \dot{m}_{w3} - \dot{m}_{w2} = \dot{m}_a (\omega_3 - \omega_2) = (36.4 \text{ kg/min})(0.00888 - 0.00581) = \mathbf{0.112 \text{ kg/min}}$$



14-134 Problem 14-133 is reconsidered. The effect of total pressure in the range 94 to 100 kPa on the results required in the problem is to be studied.

Analysis The problem is solved using EES, and the solution is given below.

```
P=101.325 [kPa]
Tdb[1] =15 [C]
Rh[1] = 0.55
Vol_dot[1]= 30 [m^3/min]
Tdb[3] = 25 [C]
Rh[3] = 0.45
P[1]=P
P[2]=P[1]
P[3]=P[1]
```

"Energy balance for the steady-flow heating process 1 to 2:"

"We neglect the PE of the flow. Since we don't know the cross sectional area of the flow streams, we also neglect the KE of the flow."

```
E_dot_in - E_dot_out = DELTAE_dot_sys
```

```
DELTA E_dot_sys = 0 [kJ/min]
```

```
E_dot_in = m_dot_a*h[1]+Q_dot_in
```

```
E_dot_out = m_dot_a*h[2]
```

"Conservation of mass of dry air during mixing: $m_{\dot{a}}$ = constant"

```
m_dot_a = Vol_dot[1]/v[1]
```

"Conservation of mass of water vapor during the heating process:"

```
m_dot_a*w[1] = m_dot_a*w[2]
```

"Conservation of mass of water vapor during the evaporative cooler process:"

```
m_dot_a*w[2]+m_dot_w = m_dot_a*w[3]
```

"During the evaporative cooler process:"

```
Twb[2] = Twb[3]
```

```
Twb[3] =WETBULB(AirH2O,T=Tdb[3],P=P[3],R=Rh[3])
```

```
h[1]=ENTHALPY(AirH2O,T=Tdb[1],P=P[1],R=Rh[1])
```

```
v[1]=VOLUME(AirH2O,T=Tdb[1],P=P[1],R=Rh[1])
```

```
w[1]=HUMRAT(AirH2O,T=Tdb[1],P=P[1],R=Rh[1])
```

```
{h[2]=ENTHALPY(AirH2O,T=Tdb[2],P=P[2],B=Twb[2])}
```

```
h[2]=h[3]
```

```
Tdb[2]=TEMPERATURE(AirH2O,h=h[2],P=P[2],w=w[2])
```

```
w[2]=HUMRAT(AirH2O,T=Tdb[2],P=P[2],R=Rh[2])
```

```
h[3]=ENTHALPY(AirH2O,T=Tdb[3],P=P[3],R=Rh[3])
```

```
w[3]=HUMRAT(AirH2O,T=Tdb[3],P=P[3],R=Rh[3])
```

P [kPa]	m_w [kg/min]	Q_{in} [kJ/min]	Rh_2	Tdb_2 [C]
94	0.1118	628.6	0.1833	33.29
95	0.1118	632.2	0.1843	33.2
96	0.1118	635.8	0.1852	33.11
97	0.1118	639.4	0.186	33.03
98	0.1118	643	0.1869	32.94
99	0.1117	646.6	0.1878	32.86
100	0.1117	650.3	0.1886	32.78

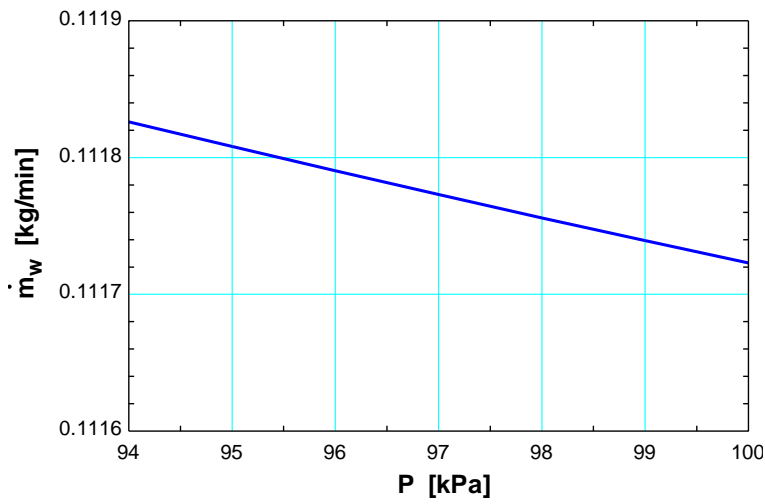
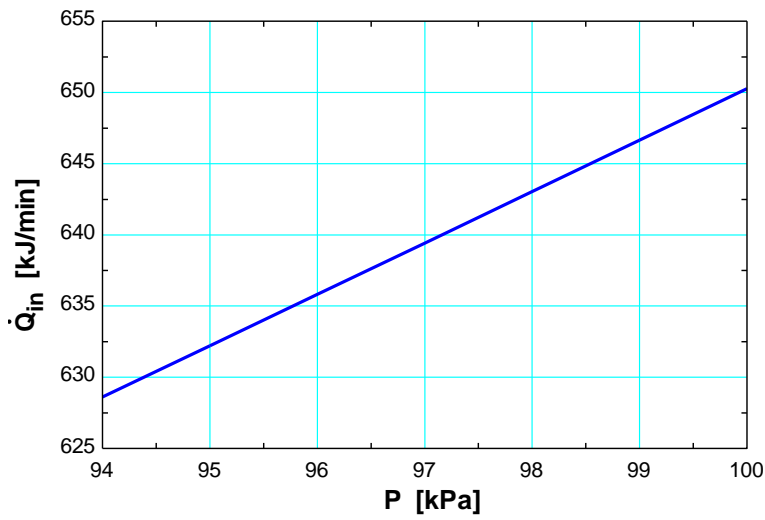
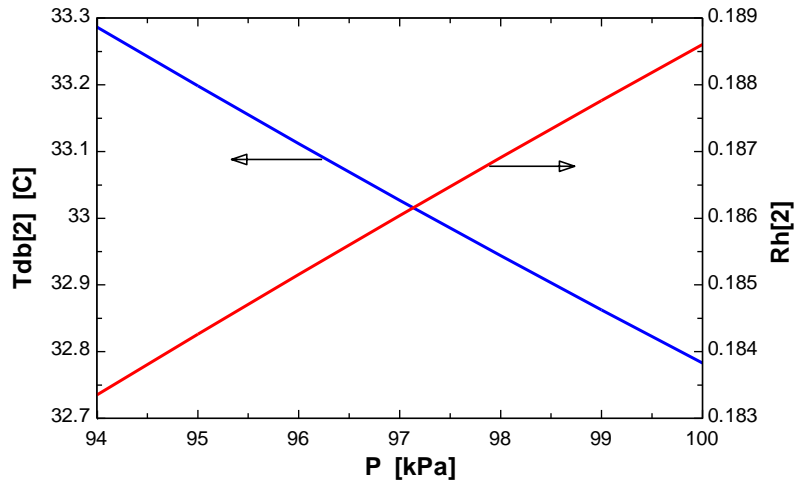

14-135 Air is heated and dehumidified in an air-conditioning system consisting of a heating section and an evaporative cooler. The temperature and relative humidity of the air when it leaves the heating section, the rate of heat transfer in the heating section, and the rate at which water is added to the air in the evaporative cooler are to be determined.

Assumptions 1 This is a steady-flow process and thus the mass flow rate of dry air remains constant during the entire process ($\dot{m}_{a1} = \dot{m}_{a2} = \dot{m}_a$). **2** Dry air and water vapor are ideal gases. **3** The kinetic and potential energy changes are negligible.

Analysis (a) Assuming the wet-bulb temperature of the air remains constant during the evaporative cooling process, the properties of air at various states are determined to be

$$P_{v1} = \phi_1 P_{g1} = \phi_1 P_{\text{sat}@15^\circ\text{C}} = (0.55)(1.7057 \text{ kPa}) = 0.938 \text{ kPa}$$

$$P_{a1} = P_1 - P_{v1} = 96 - 0.938 = 95.06 \text{ kPa}$$

$$\nu_1 = \frac{R_a T_1}{P_{a1}} = \frac{(0.287 \text{ kPa} \cdot \text{m}^3 / \text{kg} \cdot \text{K})(288 \text{ K})}{95.06 \text{ kPa}}$$

$$= 0.8695 \text{ m}^3 / \text{kg dry air}$$

$$\omega_1 = \frac{0.622 P_{v1}}{P_1 - P_{v1}} = \frac{0.622(0.938 \text{ kPa})}{(96 - 0.8695) \text{ kPa}} = 0.006138 \text{ kg H}_2\text{O/kg dry air}$$

$$h_1 = c_p T_1 + \omega_1 h_{g1} = (1.005 \text{ kJ/kg} \cdot ^\circ\text{C})(15^\circ\text{C}) + (0.006138)(2528.3 \text{ kJ/kg}) = 30.59 \text{ kJ/kg dry air}$$

and

$$P_{v3} = \phi_3 P_{g3} = \phi_3 P_{\text{sat}@25^\circ\text{C}} = (0.45)(3.17 \text{ kPa}) = 1.426 \text{ kPa}$$

$$P_{a3} = P_3 - P_{v3} = 96 - 1.426 = 94.57 \text{ kPa}$$

$$\omega_3 = \frac{0.622 P_{v3}}{P_3 - P_{v3}} = \frac{0.622(1.426 \text{ kPa})}{(96 - 1.426) \text{ kPa}} = 0.009381 \text{ kg H}_2\text{O/kg dry air}$$

$$h_3 = c_p T_3 + \omega_3 h_{g3} = (1.005 \text{ kJ/kg} \cdot ^\circ\text{C})(25^\circ\text{C}) + (0.009381)(2546.5 \text{ kJ/kg}) = 49.01 \text{ kJ/kg dry air}$$

Also,

$$h_2 \cong h_3 = 49.01 \text{ kJ/kg}$$

$$\omega_2 = \omega_1 = 0.006138 \text{ kg H}_2\text{O/kg dry air}$$

Thus,

$$h_2 = c_p T_2 + \omega_2 h_{g2} \cong c_p T_2 + \omega_2 (2500.9 + 1.82 T_2) = (1.005 \text{ kJ/kg} \cdot ^\circ\text{C}) T_2 + (0.006138)(2500.9 + 1.82 T_2)$$

Solving for T_2 ,

$$T_2 = \mathbf{33.1^\circ\text{C}} \longrightarrow P_{g2} = P_{\text{sat}@33.1^\circ\text{C}} = 5.072 \text{ kPa}$$

$$\text{Thus, } \phi_2 = \frac{\omega_2 P_2}{(0.622 + \omega_2) P_{g2}} = \frac{(0.006138)(96)}{(0.622 + 0.006138)(5.072)} = 0.185 \text{ or } \mathbf{18.5\%}$$

(b) The mass flow rate of dry air is

$$\dot{m}_a = \frac{\dot{V}_1}{\nu_1} = \frac{30 \text{ m}^3 / \text{min}}{0.8695 \text{ m}^3 / \text{kg dry air}} = 34.5 \text{ kg/min}$$

Then the rate of heat transfer to air in the heating section becomes

$$\dot{Q}_{\text{in}} = \dot{m}_a (h_2 - h_1) = (34.5 \text{ kg/min})(49.01 - 30.59) \text{ kJ/kg} = \mathbf{636 \text{ kJ/min}}$$

(c) The rate of water addition to the air in evaporative cooler is

$$\dot{m}_{w, \text{added}} = \dot{m}_{w3} - \dot{m}_{w2} = \dot{m}_a (\omega_3 - \omega_2) = (34.5 \text{ kg/min})(0.009381 - 0.006138) = \mathbf{0.112 \text{ kg/min}}$$

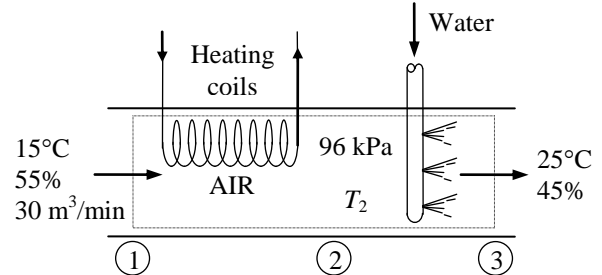

14-136 Conditioned air is to be mixed with outside air. The ratio of the dry air mass flow rates of the conditioned- to-outside air, and the temperature of the mixture are to be determined.

Assumptions 1 Steady operating conditions exist. 2 Dry air and water vapor are ideal gases. 3 The kinetic and potential energy changes are negligible. 4 The mixing chamber is adiabatic.

Properties The properties of each inlet stream are determined from the psychrometric chart (Fig. A-31) to be

$$h_1 = 34.3 \text{ kJ / kg dry air}$$

$$\omega_1 = 0.0084 \text{ kg H}_2\text{O / kg dry air}$$

and

$$h_2 = 68.5 \text{ kJ / kg dry air}$$

$$\omega_2 = 0.0134 \text{ kg H}_2\text{O / kg dry air}$$

Analysis The ratio of the dry air mass flow rates of the Conditioned air to the outside air can be determined from

$$\frac{\dot{m}_{a1}}{\dot{m}_{a2}} = \frac{\omega_2 - \omega_3}{\omega_3 - \omega_1} = \frac{h_2 - h_3}{h_3 - h_1}$$

But state 3 is not completely specified. However, we know that state 3 is on the straight line connecting states 1 and 2 on the psychrometric chart. At the intersection point of this line and $\phi = 60\%$ line we read

$$(b) \quad T_3 = 23.5^\circ\text{C}$$

$$\omega_3 = 0.0109 \text{ kg H}_2\text{O / kg dry air}$$

$$h_3 = 51.3 \text{ kJ / kg dry air}$$

Therefore, the mixture will leave at 23.5°C . The $\dot{m}_{a1}/\dot{m}_{a2}$ ratio is determined by substituting the specific humidity (or enthalpy) values into the above relation,

$$(a) \quad \frac{\dot{m}_{a1}}{\dot{m}_{a2}} = \frac{0.0134 - 0.0109}{0.0109 - 0.0084} = 1.00$$

Therefore, the mass flow rate of each stream must be the same.

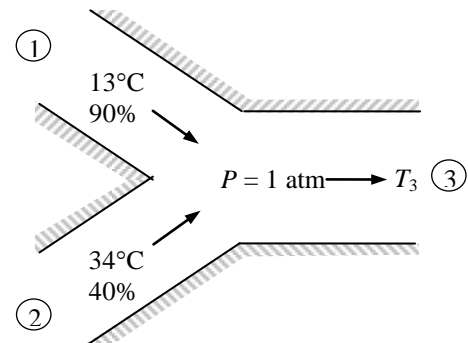



14-137 Problem 14-136 is reconsidered. The desired quantities are to be determined using EES at 1 atm and 80 kPa pressures.

Analysis The problem is solved using EES, and the solution is given below.

"Without loss of generality assume the mass flow rate of the outside air is $m_{\dot{2}} = 1 \text{ kg/s}$."

```
P=101.325 [kPa]
Tdb[1] =13 [C] "State 1 is the conditioned air"
Rh[1] = 0.90
Tdb[2] =34 [C] "State 2 is the outside air"
Rh[2] = 0.40
Rh[3] = 0.60
P[1]=P
P[2]=P[1]
P[3]=P[1]
m_dot[2] = 1 [kg/s]
MassRatio = m_dot[1]/m_dot[2]
```

"Energy balance for the steady-flow mixing process:"

"We neglect the PE of the flow. Since we don't know the cross sectional area of the flow streams, we also neglect the KE of the flow."

```
E_dot_in - E_dot_out = DELTAE_dot_sys
DELTAE_dot_sys = 0 [kW]
E_dot_in = m_dot[1]*h[1]+m_dot[2]*h[2]
E_dot_out = m_dot[3]*h[3]
```

"Conservation of mass of dry air during mixing:"

```
m_dot[1]+m_dot[2] = m_dot[3]
```

"Conservation of mass of water vapor during mixing:"

```
m_dot[1]*w[1]+m_dot[2]*w[2] = m_dot[3]*w[3]
```

```
h[1]=ENTHALPY(AirH2O,T=Tdb[1],P=P[1],R=Rh[1])
v[1]=VOLUME(AirH2O,T=Tdb[1],P=P[1],R=Rh[1])
w[1]=HUMRAT(AirH2O,T=Tdb[1],P=P[1],R=Rh[1])
```

```
h[2]=ENTHALPY(AirH2O,T=Tdb[2],P=P[2],R=Rh[2])
v[2]=VOLUME(AirH2O,T=Tdb[2],P=P[2],R=Rh[2])
w[2]=HUMRAT(AirH2O,T=Tdb[2],P=P[2],R=Rh[2])
```

```
Tdb[3]=TEMPERATURE(AirH2O,h=h[3],P=P[3],R=Rh[3])
w[3]=HUMRAT(AirH2O,T=Tdb[3],P=P[3],R=Rh[3])
v[3]=VOLUME(AirH2O,T=Tdb[3],P=P[3],w=w[3])
```

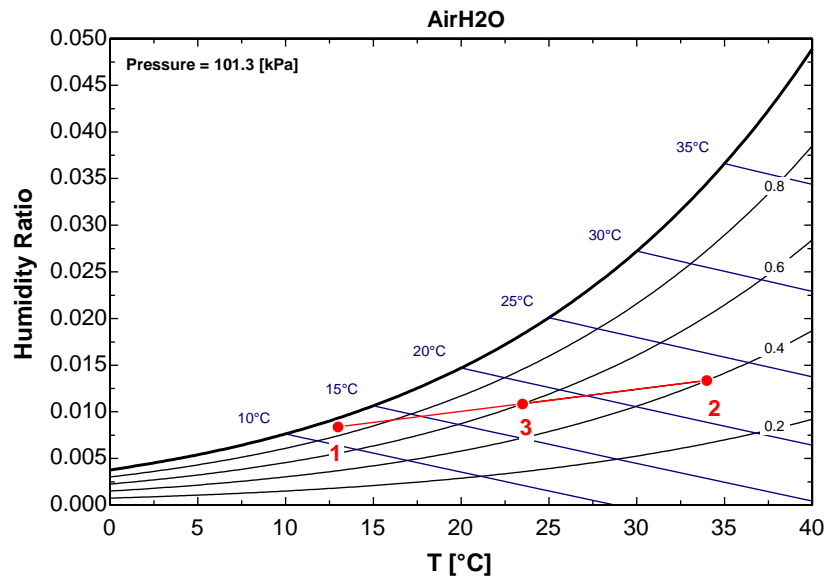

SOLUTION for P=1 atm (101.325 kPa)

DELTAE_dot_sys=0 [kW]	E_dot_in=102.9 [kW]
E_dot_out=102.9 [kW]	h[1]=34.26 [kJ/kg]
h[2]=68.45 [kJ/kg]	h[3]=51.3 [kJ/kg]
MassRatio=1.007	m_dot[1]=1.007 [kg/s]
m_dot[2]=1 [kg/s]	m_dot[3]=2.007 [kg/s]
P=101.3 [kPa]	P[1]=101.3 [kPa]
P[2]=101.3 [kPa]	P[3]=101.3 [kPa]
Rh[1]=0.9	Rh[2]=0.4
Rh[3]=0.6	Tdb[1]=13 [C]
Tdb[2]=34 [C]	Tdb[3]=23.51 [C]
v[1]=0.8215 [m ³ /kg]	v[2]=0.8888 [m ³ /kg]
v[3]=0.855 [m ³ /kg]	w[1]=0.008387
w[2]=0.01336	w[3]=0.01086

SOLUTION for P=80 kPa

DELTAE_dot_sys=0	E_dot_in=118.2 [kW]
E_dot_out=118.2 [kW]	h[1]=40 [kJ/kg]
h[2]=77.82 [kJ/kg]	h[3]=58.82 [kJ/kg]
MassRatio=1.009	m_dot[1]=1.009 [kg/s]
m_dot[2]=1 [kg/s]	m_dot[3]=2.009 [kg/s]
P=80 [kPa]	P[1]=80 [kPa]
P[2]=80 [kPa]	P[3]=80 [kPa]
Rh[1]=0.9	Rh[2]=0.4
Rh[3]=0.6	Tdb[1]=13 [C]
Tdb[2]=34 [C]	Tdb[3]=23.51 [C]
v[1]=1.044 [m ³ /kg]	v[2]=1.132 [m ³ /kg]
v[3]=1.088 [m ³ /kg]	w[1]=0.01066 [kgw/kg]
w[2]=0.01701 [kgw/kg]	w[3]=0.01382 [kgw/kg]



14-138 Waste heat from the cooling water is rejected to air in a natural-draft cooling tower. The mass flow rate of the cooling water, the volume flow rate of air, and the mass flow rate of the required makeup water are to be determined.

Assumptions 1 Steady operating conditions exist. 2 Dry air and water vapor are ideal gases. 3 The kinetic and potential energy changes are negligible. 4 The cooling tower is adiabatic.

Analysis (a) The mass flow rate of dry air through the tower remains constant ($\dot{m}_{a1} = \dot{m}_{a2} = \dot{m}_a$), but the mass flow rate of liquid water decreases by an amount equal to the amount of water that vaporizes in the tower during the cooling process. The water lost through evaporation is made up later in the cycle using water at 30°C. Applying the mass balance and the energy balance equations yields

Dry Air Mass Balance:

$$\sum \dot{m}_{a,i} = \sum \dot{m}_{a,e} \longrightarrow \dot{m}_{a1} = \dot{m}_{a2} = \dot{m}_a$$

Water Mass Balance:

$$\begin{aligned} \sum \dot{m}_{w,i} &= \sum \dot{m}_{w,e} \\ \dot{m}_3 + \dot{m}_{a1}\omega_1 &= \dot{m}_4 + \dot{m}_{a2}\omega_2 \\ \dot{m}_3 - \dot{m}_4 &= \dot{m}_a(\omega_2 - \omega_1) = \dot{m}_{\text{makeup}} \end{aligned}$$

Energy Balance:

$$\dot{E}_{\text{in}} - \dot{E}_{\text{out}} = \Delta \dot{E}_{\text{system}} \stackrel{\text{no (steady)}}{=} 0 \longrightarrow \dot{E}_{\text{in}} = \dot{E}_{\text{out}}$$

$$\begin{aligned} \sum \dot{m}_i h_i &= \sum \dot{m}_e h_e \quad (\text{since } \dot{Q} = \dot{W} = 0) \\ 0 &= \sum \dot{m}_e h_e - \sum \dot{m}_i h_i \\ 0 &= \dot{m}_{a2} h_2 + \dot{m}_4 h_4 - \dot{m}_{a1} h_1 - \dot{m}_3 h_3 \\ 0 &= \dot{m}_a (h_2 - h_1) + (\dot{m}_3 - \dot{m}_{\text{makeup}}) h_4 - \dot{m}_3 h_3 \end{aligned}$$

Solving for \dot{m}_a ,

$$\dot{m}_a = \frac{\dot{m}_3 (h_3 - h_4)}{(h_2 - h_1) - (\omega_2 - \omega_1) h_4}$$

From the psychrometric chart (Fig. A-31 or EES),

$$\begin{aligned} h_1 &= 44.67 \text{ kJ/kg dry air} \\ \omega_1 &= 0.008462 \text{ kg H}_2\text{O/kg dry air} \\ \nu_1 &= 0.8504 \text{ m}^3/\text{kg dry air} \end{aligned}$$

and

$$\begin{aligned} h_2 &= 110.69 \text{ kJ/kg dry air} \\ \omega_2 &= 0.03065 \text{ kg H}_2\text{O/kg dry air} \end{aligned}$$

From Table A-4,

$$\begin{aligned} h_3 &\cong h_f @ 42^\circ\text{C} = 175.90 \text{ kJ/kg H}_2\text{O} \\ h_4 &\cong h_f @ 30^\circ\text{C} = 125.74 \text{ kJ/kg H}_2\text{O} \end{aligned}$$

Substituting

$$\dot{m}_a = \frac{\dot{m}_3 (175.90 - 125.74) \text{ kJ/kg}}{(110.69 - 44.67) \text{ kJ/kg} - (0.03065 - 0.008462)(125.74) \text{ kJ/kg}} = 0.7933 \dot{m}_3$$

The mass flow rate of the cooling water is determined by applying the steady flow energy balance equation on the cooling water,

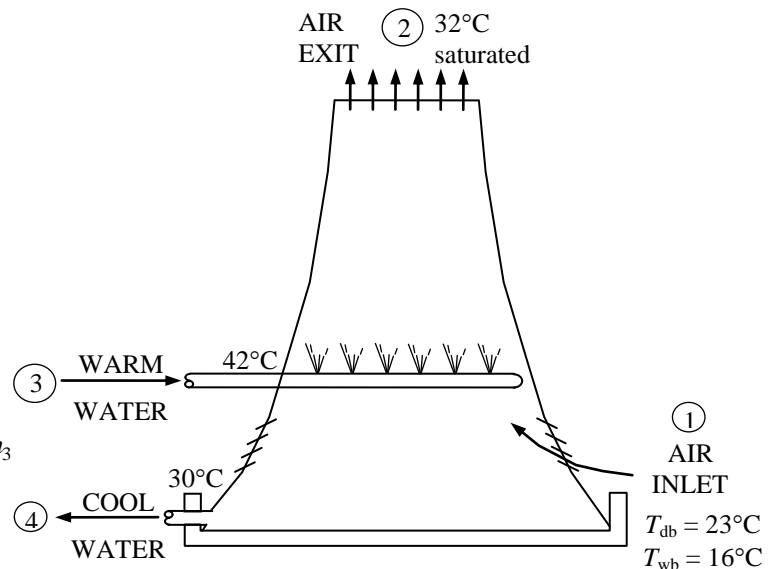

$$\begin{aligned}\dot{Q}_{\text{waste}} &= \dot{m}_3 h_3 - (\dot{m}_3 - \dot{m}_{\text{makeup}}) h_4 = \dot{m}_3 h_3 - [\dot{m}_3 - \dot{m}_a (\omega_2 - \omega_1)] h_4 \\ &= \dot{m}_3 h_3 - \dot{m}_3 [1 - 0.7933(0.03065 - 0.008462)] h_4 \\ &= \dot{m}_3 (h_3 - 0.9824 h_4)\end{aligned}$$

$$70,000 \text{ kJ/s} = \dot{m}_3 (175.90 - 0.9824 \times 125.74) \text{ kJ/kg} \longrightarrow \dot{m}_3 = \mathbf{1337 \text{ kg/s}}$$

and

$$\dot{m}_a = 0.7933 \dot{m}_3 = (0.7933)(1337 \text{ kg/s}) = 1061 \text{ kg/s}$$

(b) Then the volume flow rate of air into the cooling tower becomes

$$\dot{V}_1 = \dot{m}_a \nu_1 = (1061 \text{ kg/s})(0.8504 \text{ m}^3 / \text{kg}) = \mathbf{902 \text{ m}^3/\text{s}}$$

(c) The mass flow rate of the required makeup water is determined from

$$\dot{m}_{\text{makeup}} = \dot{m}_a (\omega_2 - \omega_1) = (1061 \text{ kg/s})(0.03065 - 0.008462) = \mathbf{23.5 \text{ kg/s}}$$



14-139 Problem 14-138 is reconsidered. The effect of air inlet wet-bulb temperature on the required air volume flow rate and the makeup water flow rate is to be investigated.

Analysis The problem is solved using EES, and the solution is given below.

"Input Data"

P_atm = 101.325 [kPa]
 T_db_1 = 23 [C]
 T_wb_1 = 16 [C]
 T_db_2 = 32 [C]
 RH_2 = 100/100 "%. relative humidity at state 2, saturated condition"
 Q_dot_waste = 70 [MW]*Convert(MW, kW)
 T_cw_3 = 42 [C] "Cooling water temperature at state 3"
 T_cw_4 = 30 [C] "Cooling water temperature at state 4"

"Dry air mass flow rates:"

"RH_1 is the relative humidity at state 1 on a decimal basis"

v_1 = VOLUME(AirH2O, T=T_db_1, P=P_atm, R=RH_1)
 T_wb_1 = WETBULB(AirH2O, T=T_db_1, P=P_atm, R=RH_1)
 m_dot_a_1 = Vol_dot_1/v_1

"Conservation of mass for the dry air (ma) in the SSSF mixing device:"

m_dot_a_in - m_dot_a_out = DELTAm_dot_a_cv
 m_dot_a_in = m_dot_a_1
 m_dot_a_out = m_dot_a_2
 DELTAm_dot_a_cv = 0 "Steady flow requirement"

"Conservation of mass for the water vapor (mv) and cooling water for the SSSF process:"

m_dot_w_in - m_dot_w_out = DELTAm_dot_w_cv
 m_dot_w_in = m_dot_v_1 + m_dot_cw_3
 m_dot_w_out = m_dot_v_2 + m_dot_cw_4
 DELTAm_dot_w_cv = 0 "Steady flow requirement"
 w_1 = HUMRAT(AirH2O, T=T_db_1, P=P_atm, R=RH_1)
 m_dot_v_1 = m_dot_a_1*w_1
 w_2 = HUMRAT(AirH2O, T=T_db_2, P=P_atm, R=RH_2)
 m_dot_v_2 = m_dot_a_2*w_2

"Conservation of energy for the SSSF cooling tower process:"

"The process is adiabatic and has no work done, neglect ke and pe"

E_dot_in_tower - E_dot_out_tower = DELTAE_dot_tower_cv
 E_dot_in_tower = m_dot_a_1*h[1] + m_dot_cw_3*h_w[3]
 E_dot_out_tower = m_dot_a_2*h[2] + m_dot_cw_4*h_w[4]
 DELTAE_dot_tower_cv = 0 "Steady flow requirement"
 h[1] = ENTHALPY(AirH2O, T=T_db_1, P=P_atm, w=w_1)
 h[2] = ENTHALPY(AirH2O, T=T_db_2, P=P_atm, w=w_2)
 h_w[3] = ENTHALPY(steam, T=T_cw_3, x=0)
 h_w[4] = ENTHALPY(steam, T=T_cw_4, x=0)

"Energy balance on the external heater determines the cooling water flow rate:"

E_dot_in_heater - E_dot_out_heater = DELTAE_dot_heater_cv
 E_dot_in_heater = Q_dot_waste + m_dot_cw_4*h_w[4]
 E_dot_out_heater = m_dot_cw_3*h_w[3]
 DELTAE_dot_heater_cv = 0 "Steady flow requirement"

"Conservation of mass on the external heater gives the makeup water flow rate."

"Note: The makeup water flow rate equals the amount of water vaporized in the cooling tower."

$m_{\dot{c}w_in} - m_{\dot{c}w_out} = \Delta m_{\dot{c}w_cv}$
 $m_{\dot{c}w_in} = m_{\dot{c}w_4} + m_{\dot{c}w_makeup}$
 $m_{\dot{c}w_out} = m_{\dot{c}w_3}$
 $\Delta m_{\dot{c}w_cv} = 0$ "Steady flow requirement"

T_{wb1} [C]	Vol_1 [m ³ /s]	m_{makeup} [kgw/s]	m_{cw3} [kgw/s]	m_{a1} [kga/s]
14	828.2	23.84	1336	977.4
15	862.7	23.69	1336	1016
16	901.7	23.53	1337	1060
17	946	23.34	1337	1110
18	996.7	23.12	1338	1168
19	1055	22.87	1338	1234
20	1124	22.58	1339	1312
21	1206	22.23	1340	1404
22	1304	21.82	1341	1515
23	1424	21.3	1342	1651

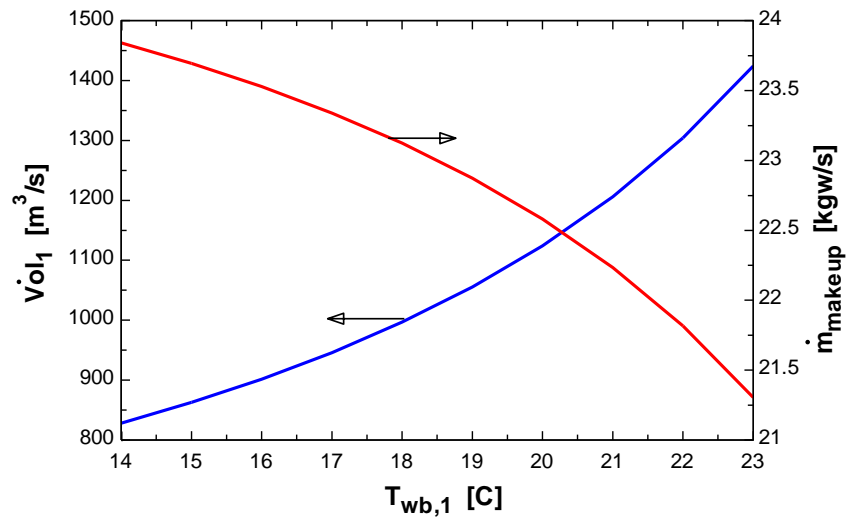

Fundamentals of Engineering (FE) Exam Problems

14-140 A room is filled with saturated moist air at 25°C and a total pressure of 100 kPa. If the mass of dry air in the room is 100 kg, the mass of water vapor is

- (a) 0.52 kg (b) 1.97 kg (c) 2.96 kg (d) 2.04 kg (e) 3.17 kg

Answer (d) 2.04 kg

Solution Solved by EES Software. Solutions can be verified by copying-and-pasting the following lines on a blank EES screen. (Similar problems and their solutions can be obtained easily by modifying numerical values).

```
T1=25 "C"
P=100 "kPa"
m_air=100 "kg"
RH=1
P_g=PRESSURE(Steam_IAPWS,T=T1,x=0)
RH=P_v/P_g
P_air=P-P_v
w=0.622*P_v/(P-P_v)
w=m_v/m_air
```

"Some Wrong Solutions with Common Mistakes:"

```
W1_vmass=m_air*w1; w1=0.622*P_v/P "Using P instead of P-Pv in w relation"
W2_vmass=m_air "Taking m_vapor = m_air"
W3_vmass=P_v/P*m_air "Using wrong relation"
```

14-141 A room contains 65 kg of dry air and 0.6 kg of water vapor at 25°C and 90 kPa total pressure. The relative humidity of air in the room is

- (a) 3.5% (b) 41.5% (c) 55.2% (d) 60.9% (e) 73.0%

Answer (b) 41.5%

Solution Solved by EES Software. Solutions can be verified by copying-and-pasting the following lines on a blank EES screen. (Similar problems and their solutions can be obtained easily by modifying numerical values).

```
T1=25 "C"
P=90 "kPa"
m_air=65 "kg"
m_v=0.6 "kg"
w=0.622*P_v/(P-P_v)
w=m_v/m_air
P_g=PRESSURE(Steam_IAPWS,T=T1,x=0)
RH=P_v/P_g
```

"Some Wrong Solutions with Common Mistakes:"

```
W1_RH=m_v/(m_air+m_v) "Using wrong relation"
W2_RH=P_g/P "Using wrong relation"
```

14-142 A 40-m³ room contains air at 30°C and a total pressure of 90 kPa with a relative humidity of 75 percent. The mass of dry air in the room is

- (a) 24.7 kg (b) 29.9 kg (c) 39.9 kg (d) 41.4 kg (e) 52.3 kg

Answer (c) 39.9 kg

Solution Solved by EES Software. Solutions can be verified by copying-and-pasting the following lines on a blank EES screen. (Similar problems and their solutions can be obtained easily by modifying numerical values).

```
V=40 "m^3"
T1=30 "C"
P=90 "kPa"
RH=0.75
P_g=PRESSURE(Steam_IAPWS,T=T1,x=0)
RH=P_v/P_g
P_air=P-P_v
R_air=0.287 "kJ/kg.K"
m_air=P_air*V/(R_air*(T1+273))
```

"Some Wrong Solutions with Common Mistakes:"

```
W1_mass=P_air*V/(R_air*T1) "Using C instead of K"
W2_mass=P*V/(R_air*(T1+273)) "Using P instead of P_air"
W3_mass=m_air*RH "Using wrong relation"
```

14-143 A room contains air at 30°C and a total pressure of 96.0 kPa with a relative humidity of 75 percent. The partial pressure of dry air is

- (a) 82.0 kPa (b) 85.8 kPa (c) 92.8 kPa (d) 90.6 kPa (e) 72.0 kPa

Answer (c) 92.8 kPa

Solution Solved by EES Software. Solutions can be verified by copying-and-pasting the following lines on a blank EES screen. (Similar problems and their solutions can be obtained easily by modifying numerical values).

```
T1=30 "C"
P=96 "kPa"
RH=0.75
P_g=PRESSURE(Steam_IAPWS,T=T1,x=0)
RH=P_v/P_g
P_air=P-P_v
```

"Some Wrong Solutions with Common Mistakes:"

```
W1_Pair=P_v "Using Pv as P_air"
W2_Pair=P-P_g "Using wrong relation"
W3_Pair=RH*P "Using wrong relation"
```

14-144 The air in a house is at 25°C and 65 percent relative humidity. Now the air is cooled at constant pressure. The temperature at which the moisture in the air will start condensing is

- (a) 7.4°C (b) 16.3°C (c) 18.0°C (d) 11.3°C (e) 20.2°C

Answer (c) 18.0°C

Solution Solved by EES Software. Solutions can be verified by copying-and-pasting the following lines on a blank EES screen. (Similar problems and their solutions can be obtained easily by modifying numerical values).

```
T1=25 "C"
RH1=0.65
P_g=PRESSURE(Steam_IAPWS,T=T1,x=0)
RH1=P_v/P_g
T_dp=TEMPERATURE(Steam_IAPWS,x=0,P=P_v)
```

"Some Wrong Solutions with Common Mistakes:"

W1_Tdp=T1*RH1 "Using wrong relation"

W2_Tdp=(T1+273)*RH1-273 "Using wrong relation"

W3_Tdp=WETBULB(AirH2O,T=T1,P=P1,R=RH1); P1=100 "Using wet-bulb temperature"

14-145 On the psychrometric chart, a cooling and dehumidification process appears as a line that is

- (a) horizontal to the left,
 (b) vertical downward,
 (c) diagonal upwards to the right (NE direction)
 (d) diagonal upwards to the left (NW direction)
 (e) diagonal downwards to the left (SW direction)

Answer (e) diagonal downwards to the left (SW direction)

14-146 On the psychrometric chart, a heating and humidification process appears as a line that is

- (a) horizontal to the right,
 (b) vertical upward,
 (c) diagonal upwards to the right (NE direction)
 (d) diagonal upwards to the left (NW direction)
 (e) diagonal downwards to the right (SE direction)

Answer (c) diagonal upwards to the right (NE direction)

14-147 An air stream at a specified temperature and relative humidity undergoes evaporative cooling by spraying water into it at about the same temperature. The lowest temperature the air stream can be cooled to is

- (a) the dry bulb temperature at the given state
- (b) the wet bulb temperature at the given state
- (c) the dew point temperature at the given state
- (d) the saturation temperature corresponding to the humidity ratio at the given state
- (e) the triple point temperature of water

Answer (a) the dry bulb temperature at the given state

14-148 Air is cooled and dehumidified as it flows over the coils of a refrigeration system at 85 kPa from 35°C and a humidity ratio of 0.023 kg/kg dry air to 15°C and a humidity ratio of 0.015 kg/kg dry air. If the mass flow rate of dry air is 0.4 kg/s, the rate of heat removal from the air is

- (a) 4 kJ/s
- (b) 8 kJ/s
- (c) 12 kJ/s
- (d) 16 kJ/s
- (e) 20 kJ/s

Answer (d) 16 kJ/s

Solution Solved by EES Software. Solutions can be verified by copying-and-pasting the following lines on a blank EES screen. (Similar problems and their solutions can be obtained easily by modifying numerical values).

```
P=85 "kPa"
T1=35 "C"
w1=0.023
T2=15 "C"
w2=0.015
m_air=0.4 "kg/s"
m_water=m_air*(w1-w2)
h1=ENTHALPY(AirH2O,T=T1,P=P,w=w1)
h2=ENTHALPY(AirH2O,T=T2,P=P,w=w2)
h_w=ENTHALPY(Steam_IAPWS,T=T2,x=0)
Q=m_air*(h1-h2)-m_water*h_w
```

"Some Wrong Solutions with Common Mistakes:"

W1_Q=m_air*(h1-h2) "Ignoring condensed water"

W2_Q=m_air*Cp_air*(T1-T2)-m_water*h_w; Cp_air = 1.005 "Using dry air enthalpies"

W3_Q=m_air*(h1-h2)+m_water*h_w "Using wrong sign"

14-149 Air at a total pressure of 90 kPa, 15°C, and 75 percent relative humidity is heated and humidified to 25°C and 75 percent relative humidity by introducing water vapor. If the mass flow rate of dry air is 4 kg/s, the rate at which steam is added to the air is

- (a) 0.032 kg/s (b) 0.013 kg/s (c) 0.019 kg/s (d) 0.0079 kg/s (e) 0 kg/s

Answer (a) 0.032 kg/s

Solution Solved by EES Software. Solutions can be verified by copying-and-pasting the following lines on a blank EES screen. (Similar problems and their solutions can be obtained easily by modifying numerical values).

```
P=90 "kPa"
T1=15 "C"
RH1=0.75
T2=25 "C"
RH2=0.75
m_air=4 "kg/s"
w1=HUMRAT(AirH2O,T=T1,P=P,R=RH1)
w2=HUMRAT(AirH2O,T=T2,P=P,R=RH2)
m_water=m_air*(w2-w1)
```

"Some Wrong Solutions with Common Mistakes:"

```
W1_mv=0 "sine RH = constant"
W2_mv=w2-w1 "Ignoring mass flow rate of air"
W3_mv=RH1*m_air "Using wrong relation"
```

14-150 ... 14-154 Design and Essay Problems



Solutions Manual for
Thermodynamics: An Engineering Approach
8th Edition
Yunus A. Çengel, Michael A. Boles
McGraw-Hill, 2015

Chapter 15
CHEMICAL REACTIONS

PROPRIETARY AND CONFIDENTIAL

This Manual is the proprietary property of McGraw-Hill Education and protected by copyright and other state and federal laws. By opening and using this Manual the user agrees to the following restrictions, and if the recipient does not agree to these restrictions, the Manual should be promptly returned unopened to McGraw-Hill Education: **This Manual is being provided only to authorized professors and instructors for use in preparing for the classes using the affiliated textbook. No other use or distribution of this Manual is permitted. This Manual may not be sold and may not be distributed to or used by any student or other third party. No part of this Manual may be reproduced, displayed or distributed in any form or by any means, electronic or otherwise, without the prior written permission of McGraw-Hill Education.**

Fuels and Combustion

15-1C Nitrogen, in general, does not react with other chemical species during a combustion process but its presence affects the outcome of the process because nitrogen absorbs a large proportion of the heat released during the chemical process.

15-2C The number of atoms are preserved during a chemical reaction, but the total mole numbers are not.

15-3C Air-fuel ratio is the ratio of the mass of air to the mass of fuel during a combustion process. Fuel-air ratio is the inverse of the air-fuel ratio.

15-4C No. Because the molar mass of the fuel and the molar mass of the air, in general, are different.

15-5C The dew-point temperature of the product gases is the temperature at which the water vapor in the product gases starts to condense as the gases are cooled at constant pressure. It is the saturation temperature corresponding to the vapor pressure of the product gases.

15-6 Sulfur is burned with oxygen to form sulfur dioxide. The minimum mass of oxygen required and the mass of sulfur dioxide in the products are to be determined when 1 kg of sulfur is burned.

Properties The molar masses of sulfur and oxygen are 32.06 kg/kmol and 32.00 kg/kmol, respectively (Table A-1).

Analysis The chemical reaction is given by

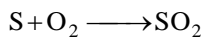

Hence, 1 kmol of oxygen is required to burn 1 kmol of sulfur which produces 1 kmol of sulfur dioxide whose molecular weight is

$$M_{\text{SO}_2} = M_{\text{S}} + M_{\text{O}_2} = 32.06 + 32.00 = 64.06 \text{ kg/kmol}$$

Then,

$$\frac{m_{\text{O}_2}}{m_{\text{S}}} = \frac{N_{\text{O}_2} M_{\text{O}_2}}{N_{\text{S}} M_{\text{S}}} = \frac{(1 \text{ kmol})(32 \text{ kg/kmol})}{(1 \text{ kmol})(32.06 \text{ kg/kmol})} = \mathbf{0.998 \text{ kg O}_2/\text{kg S}}$$

and

$$\frac{m_{\text{SO}_2}}{m_{\text{S}}} = \frac{N_{\text{SO}_2} M_{\text{SO}_2}}{N_{\text{S}} M_{\text{S}}} = \frac{(1 \text{ kmol})(64.06 \text{ kg/kmol})}{(1 \text{ kmol})(32.06 \text{ kg/kmol})} = \mathbf{1.998 \text{ kg SO}_2/\text{kg S}}$$

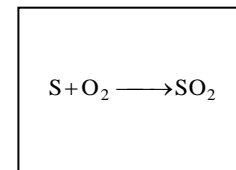

15-7E Methane is burned with diatomic oxygen. The mass of water vapor in the products is to be determined when 1 lbm of methane is burned.

Properties The molar masses of CH₄, O₂, CO₂, and H₂O are 16, 32, 44, and 18 lbm/lbmol, respectively (Table A-1E).

Analysis The chemical reaction is given by

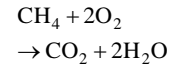
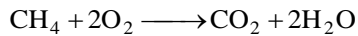

Hence, for each lbmol of methane burned, 2 lbmol of water vapor are formed. Then,

$$\frac{m_{\text{H}_2\text{O}}}{m_{\text{CH}_4}} = \frac{N_{\text{H}_2\text{O}}M_{\text{H}_2\text{O}}}{N_{\text{CH}_4}M_{\text{CH}_4}} = \frac{(2 \text{ lbmol})(18 \text{ lbm/lbmol})}{(1 \text{ lbmol})(16 \text{ lbm/lbmol})} = \mathbf{2.25 \text{ lbm H}_2\text{O/lbm CH}_4}$$

Theoretical and Actual Combustion Processes

15-8C It represent the amount of air that contains the exact amount of oxygen needed for complete combustion.

15-9C Case (b).

15-10C No. The theoretical combustion is also complete, but the products of theoretical combustion does not contain any uncombined oxygen.

15-11C The causes of incomplete combustion are insufficient time, insufficient oxygen, insufficient mixing, and dissociation.

15-12C CO. Because oxygen is more strongly attracted to hydrogen than it is to carbon, and hydrogen is usually burned to completion even when there is a deficiency of oxygen.

15-13 Methane is burned with the stoichiometric amount of air during a combustion process. The AF and FA ratios are to be determined.

Assumptions 1 Combustion is complete. **2** The combustion products contain CO_2 , H_2O , and N_2 only.

Properties The molar masses of C, H_2 , and air are 12 kg/kmol, 2 kg/kmol, and 29 kg/kmol, respectively (Table A-1).

Analysis This is a theoretical combustion process since methane is burned completely with stoichiometric amount of air. The stoichiometric combustion equation of CH_4 is

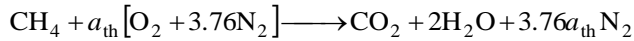

$$\text{O}_2 \text{ balance: } a_{\text{th}} = 1 + 1 \longrightarrow a_{\text{th}} = 2$$

Substituting,

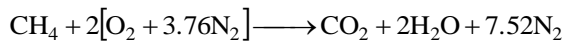

The air-fuel ratio is determined by taking the ratio of the mass of the air to the mass of the fuel,

$$\text{AF} = \frac{m_{\text{air}}}{m_{\text{fuel}}} = \frac{(2 \times 4.76 \text{ kmol})(29 \text{ kg/kmol})}{(1 \text{ kmol})(12 \text{ kg/kmol}) + (2 \text{ kmol})(2 \text{ kg/kmol})} = \mathbf{17.3 \text{ kg air/kg fuel}}$$

The fuel-air ratio is the inverse of the air-fuel ratio,

$$\text{FA} = \frac{1}{\text{AF}} = \frac{1}{17.3 \text{ kg air/kg fuel}} = \mathbf{0.0578 \text{ kg fuel/kg air}}$$

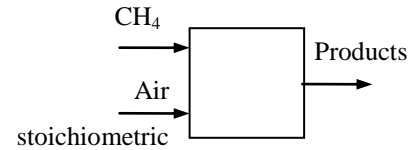

15-14 Propane is burned with theoretical amount of air. The mass fraction of carbon dioxide and the mole and mass fractions of the water vapor in the products are to be determined.

Properties The molar masses of C_3H_8 , O_2 , N_2 , CO_2 , and H_2O are 44, 32, 28, 44, and 18 kg/kmol, respectively (Table A-1).

Analysis (a) The reaction in terms of undetermined coefficients is

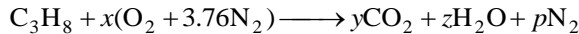

Balancing the carbon in this reaction gives

$$y = 3$$

and the hydrogen balance gives

$$2z = 8 \longrightarrow z = 4$$

The oxygen balance produces

$$2x = 2y + z \longrightarrow x = y + z/2 = 3 + 4/2 = 5$$

A balance of the nitrogen in this reaction gives

$$2 \times 3.76x = 2p \longrightarrow p = 3.76x = 3.76 \times 5 = 18.8$$

In balanced form, the reaction is

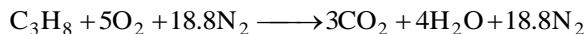

The mass fraction of carbon dioxide is determined from

$$\begin{aligned} mf_{CO_2} &= \frac{m_{CO_2}}{m_{products}} = \frac{N_{CO_2}M_{CO_2}}{N_{CO_2}M_{CO_2} + N_{H_2O}M_{H_2O} + N_{N_2}M_{N_2}} \\ &= \frac{(3 \text{ kmol})(44 \text{ kg/kmol})}{(3 \text{ kmol})(44 \text{ kg/kmol}) + (4 \text{ kmol})(18 \text{ kg/kmol}) + (18.8 \text{ kmol})(28 \text{ kg/kmol})} \\ &= \frac{132 \text{ kg}}{730.4 \text{ kg}} = \mathbf{0.181} \end{aligned}$$

(b) The mole and mass fractions of water vapor are

$$y_{H_2O} = \frac{N_{H_2O}}{N_{products}} = \frac{N_{H_2O}}{N_{CO_2} + N_{H_2O} + N_{N_2}} = \frac{4 \text{ kmol}}{3 \text{ kmol} + 4 \text{ kmol} + 18.8 \text{ kmol}} = \frac{4 \text{ kmol}}{25.8 \text{ kmol}} = \mathbf{0.155}$$

$$\begin{aligned} mf_{H_2O} &= \frac{m_{H_2O}}{m_{products}} = \frac{N_{H_2O}M_{H_2O}}{N_{CO_2}M_{CO_2} + N_{H_2O}M_{H_2O} + N_{N_2}M_{N_2}} \\ &= \frac{(4 \text{ kmol})(18 \text{ kg/kmol})}{(3 \text{ kmol})(44 \text{ kg/kmol}) + (4 \text{ kmol})(18 \text{ kg/kmol}) + (18.8 \text{ kmol})(28 \text{ kg/kmol})} \\ &= \frac{72 \text{ kg}}{730.4 \text{ kg}} \\ &= \mathbf{0.0986} \end{aligned}$$

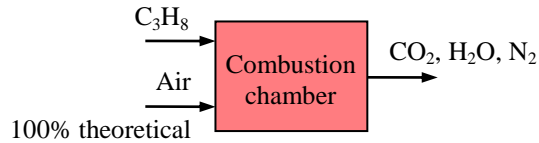

15-15 n-Butane is burned with stoichiometric amount of oxygen. The mole fractions of CO₂ water in the products and the mole number of CO₂ in the products per mole of fuel burned are to be determined.

Assumptions **1** Combustion is complete. **2** The combustion products contain CO₂ and H₂O. **3** Combustion gases are ideal gases.

Properties The molar masses of C, H₂, and O₂ are 12 kg/kmol, 2 kg/kmol, and 32 kg/kmol, respectively (Table A-1).

Analysis The combustion equation in this case is

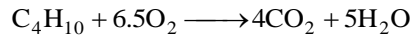

The total mole of the products are $4+5 = 9$ kmol. Then the mole fractions are

$$y_{\text{CO}_2} = \frac{N_{\text{CO}_2}}{N_{\text{total}}} = \frac{4 \text{ kmol}}{9 \text{ kmol}} = \mathbf{0.4444}$$

$$y_{\text{H}_2\text{O}} = \frac{N_{\text{H}_2\text{O}}}{N_{\text{total}}} = \frac{5 \text{ kmol}}{9 \text{ kmol}} = \mathbf{0.5556}$$

Also,

$$N_{\text{CO}_2} = \mathbf{4 \text{ kmol CO}_2/\text{kmol C}_4\text{H}_{10}}$$

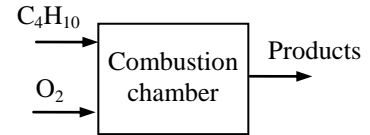

15-16 Acetylene is burned with 25 percent excess oxygen. The mass fractions of each of the products and the mass of oxygen used per unit mass of fuel burned are to be determined.

Assumptions 1 Combustion is complete. **2** The combustion products contain CO_2 , H_2O , and O_2 . **3** Combustion gases are ideal gases.

Properties The molar masses of C, H_2 , and O_2 are 12 kg/kmol, 2 kg/kmol, and 32 kg/kmol, respectively (Table A-1).

Analysis The stoichiometric combustion equation is

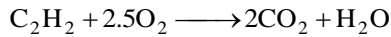

The combustion equation with 25% excess oxygen is

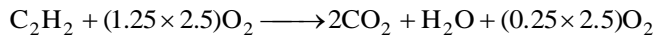

or

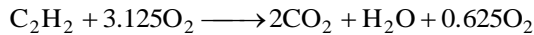

The mass of each product and the total mass are

$$m_{\text{CO}_2} = N_{\text{CO}_2} M_{\text{CO}_2} = (2 \text{ kmol})(44 \text{ kg/kmol}) = 88 \text{ kg}$$

$$m_{\text{H}_2\text{O}} = N_{\text{H}_2\text{O}} M_{\text{H}_2\text{O}} = (1 \text{ kmol})(18 \text{ kg/kmol}) = 18 \text{ kg}$$

$$m_{\text{O}_2} = N_{\text{O}_2} M_{\text{O}_2} = (0.625 \text{ kmol})(32 \text{ kg/kmol}) = 20 \text{ kg}$$

$$m_{\text{total}} = m_{\text{CO}_2} + m_{\text{H}_2\text{O}} + m_{\text{O}_2} = 88 + 18 + 20 = 126 \text{ kg}$$

Then the mass fractions are

$$\text{mf}_{\text{CO}_2} = \frac{m_{\text{CO}_2}}{m_{\text{total}}} = \frac{88 \text{ kg}}{126 \text{ kg}} = \mathbf{0.6984}$$

$$\text{mf}_{\text{H}_2\text{O}} = \frac{m_{\text{H}_2\text{O}}}{m_{\text{total}}} = \frac{18 \text{ kg}}{126 \text{ kg}} = \mathbf{0.1429}$$

$$\text{mf}_{\text{O}_2} = \frac{m_{\text{O}_2}}{m_{\text{total}}} = \frac{20 \text{ kg}}{126 \text{ kg}} = \mathbf{0.1587}$$

The mass of oxygen per unit mass of fuel burned is determined from

$$\frac{m_{\text{O}_2}}{m_{\text{C}_2\text{H}_2}} = \frac{(3.125 \times 32) \text{ kg}}{(1 \times 26) \text{ kg}} = \mathbf{3.846 \text{ kg O}_2/\text{kg C}_2\text{H}_2}$$

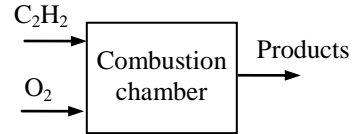

15-17 Propyl alcohol C_3H_7OH is burned with 50 percent excess air. The balanced reaction equation for complete combustion is to be written and the air-to-fuel ratio is to be determined.

Assumptions 1 Combustion is complete. 2 The combustion products contain CO_2 , H_2O , O_2 , and N_2 only.

Properties The molar masses of C, H_2 , O_2 and air are 12 kg/kmol, 2 kg/kmol, 32 kg/kmol, and 29 kg/kmol, respectively (Table A-1).

Analysis The combustion equation in this case can be written as

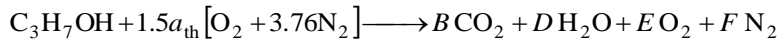

where a_{th} is the stoichiometric coefficient for air. We have automatically accounted for the 50% excess air by using the factor $1.5a_{th}$ instead of a_{th} for air. The coefficient a_{th} and other coefficients are to be determined from the mass balances

Carbon balance: $B = 3$

Hydrogen balance: $2D = 8 \longrightarrow D = 4$

Oxygen balance: $1 + 2 \times 1.5a_{th} = 2B + D + 2E$

$$0.5a_{th} = E$$

Nitrogen balance: $1.5a_{th} \times 3.76 = F$

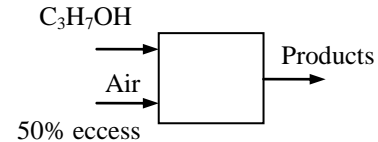

Solving the above equations, we find the coefficients ($E = 2.25$, $F = 25.38$, and $a_{th} = 4.5$) and write the balanced reaction equation as

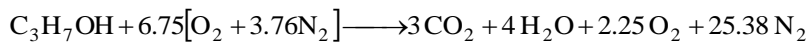

The air-fuel ratio is determined by taking the ratio of the mass of the air to the mass of the fuel,

$$AF = \frac{m_{air}}{m_{fuel}} = \frac{(6.75 \times 4.75 \text{ kmol})(29 \text{ kg/kmol})}{(3 \times 12 + 8 \times 1 + 1 \times 16) \text{ kg}} = \mathbf{15.51 \text{ kg air/kg fuel}}$$

15-18 n-Octane is burned with 50 percent excess air. The mole fractions of each of the products, the mass of water in the products per unit mass of the fuel, and the mass fraction of each reactant are to be determined.

Assumptions 1 Combustion is complete. **2** The combustion products contain CO_2 , H_2O , O_2 , and N_2 only.

Properties The molar masses of C, H_2 , O_2 , and air are 12 kg/kmol, 2 kg/kmol, 32 kg/kmol, and 29 kg/kmol, respectively (Table A-1).

Analysis The combustion equation in this case can be written as

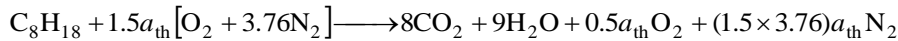

where a_{th} is the stoichiometric coefficient for air. We have automatically accounted for the 50% excess air by using the factor $1.5a_{\text{th}}$ instead of a_{th} for air. The stoichiometric amount of oxygen ($a_{\text{th}}\text{O}_2$) will be used to oxidize the fuel, and the remaining excess amount ($0.5a_{\text{th}}\text{O}_2$) will appear in the products as free oxygen. The coefficient a_{th} is determined from the O_2 balance,

$$\text{O}_2 \text{ balance: } 1.5a_{\text{th}} = 8 + 4.5 + 0.5a_{\text{th}} \longrightarrow a_{\text{th}} = 12.5$$

$$\text{Substituting, } \text{C}_8\text{H}_{18} + 18.75[\text{O}_2 + 3.76\text{N}_2] \longrightarrow 8\text{CO}_2 + 9\text{H}_2\text{O} + 6.25\text{O}_2 + 70.5\text{N}_2$$

The mass of each product and the total mass are

$$m_{\text{CO}_2} = N_{\text{CO}_2}M_{\text{CO}_2} = (8 \text{ kmol})(44 \text{ kg/kmol}) = 352 \text{ kg}$$

$$m_{\text{H}_2\text{O}} = N_{\text{H}_2\text{O}}M_{\text{H}_2\text{O}} = (9 \text{ kmol})(18 \text{ kg/kmol}) = 162 \text{ kg}$$

$$m_{\text{O}_2} = N_{\text{O}_2}M_{\text{O}_2} = (6.25 \text{ kmol})(32 \text{ kg/kmol}) = 200 \text{ kg}$$

$$m_{\text{N}_2} = N_{\text{N}_2}M_{\text{N}_2} = (70.5 \text{ kmol})(28 \text{ kg/kmol}) = 1974 \text{ kg}$$

$$m_{\text{total}} = m_{\text{CO}_2} + m_{\text{H}_2\text{O}} + m_{\text{O}_2} + m_{\text{N}_2} = 352 + 162 + 200 + 1974 = 2688 \text{ kg}$$

Then the mass fractions are

$$\text{mf}_{\text{CO}_2} = \frac{m_{\text{CO}_2}}{m_{\text{total}}} = \frac{352 \text{ kg}}{2688 \text{ kg}} = \mathbf{0.1310}$$

$$\text{mf}_{\text{H}_2\text{O}} = \frac{m_{\text{H}_2\text{O}}}{m_{\text{total}}} = \frac{162 \text{ kg}}{2688 \text{ kg}} = \mathbf{0.0603}$$

$$\text{mf}_{\text{O}_2} = \frac{m_{\text{O}_2}}{m_{\text{total}}} = \frac{200 \text{ kg}}{2688 \text{ kg}} = \mathbf{0.0744}$$

$$\text{mf}_{\text{N}_2} = \frac{m_{\text{N}_2}}{m_{\text{total}}} = \frac{1974 \text{ kg}}{2688 \text{ kg}} = \mathbf{0.7344}$$

The mass of water per unit mass of fuel burned is

$$\frac{m_{\text{H}_2\text{O}}}{m_{\text{C}_8\text{H}_{18}}} = \frac{(9 \times 18) \text{ kg}}{(1 \times 114) \text{ kg}} = \mathbf{1.421 \text{ kg H}_2\text{O/kg C}_8\text{H}_{18}}$$

The mass of each reactant and the total mass are

$$m_{\text{C}_8\text{H}_{18}} = N_{\text{C}_8\text{H}_{18}}M_{\text{C}_8\text{H}_{18}} = (1 \text{ kmol})(114 \text{ kg/kmol}) = 114 \text{ kg}$$

$$m_{\text{air}} = N_{\text{air}}M_{\text{air}} = (17.75 \times 4.76 \text{ kmol})(29 \text{ kg/kmol}) = 2588 \text{ kg}$$

$$m_{\text{total}} = m_{\text{C}_8\text{H}_{18}} + m_{\text{air}} = 114 + 2588 = 2702 \text{ kg}$$

Then the mass fractions of reactants are

$$\text{mf}_{\text{C}_8\text{H}_{18}} = \frac{m_{\text{C}_8\text{H}_{18}}}{m_{\text{total}}} = \frac{114 \text{ kg}}{2702 \text{ kg}} = \mathbf{0.0422}$$

$$\text{mf}_{\text{air}} = \frac{m_{\text{air}}}{m_{\text{total}}} = \frac{2588 \text{ kg}}{2702 \text{ kg}} = \mathbf{0.9578}$$

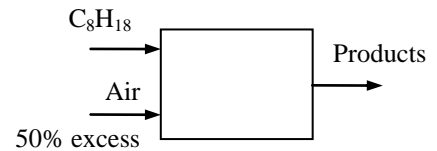

15-19 Ethane is burned with air steadily. The mass flow rates of ethane and air are given. The percentage of excess air used is to be determined.

Assumptions 1 Combustion is complete. **2** The combustion products contain CO_2 , H_2O , and N_2 only.

Properties The molar masses of C, H_2 , and air are 12 kg/kmol, 2 kg/kmol, and 29 kg/kmol, respectively (Table A-1).

Analysis The theoretical combustion equation in this case can be written as

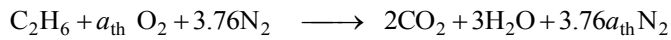

where a_{th} is the stoichiometric coefficient for air. It is determined from

$$\text{O}_2 \text{ balance: } a_{\text{th}} = 2 + 1.5 \longrightarrow a_{\text{th}} = 3.5$$

The air-fuel ratio for the theoretical reaction is determined by taking the ratio of the mass of the air to the mass of the fuel for,

$$\text{AF}_{\text{th}} = \frac{m_{\text{air,th}}}{m_{\text{fuel}}} = \frac{(3.5 \times 4.76 \text{ kmol})(29 \text{ kg/kmol})}{(2 \text{ kmol})(12 \text{ kg/kmol}) + (3 \text{ kmol})(2 \text{ kg/kmol})} = 16.1 \text{ kg air/kg fuel}$$

The actual air-fuel ratio used is

$$\text{AF}_{\text{act}} = \frac{\dot{m}_{\text{air}}}{\dot{m}_{\text{fuel}}} = \frac{176 \text{ kg/h}}{8 \text{ kg/h}} = 22 \text{ kgair/kgfuel}$$

Then the percent theoretical air used can be determined from

$$\text{Percent theoretical air} = \frac{\text{AF}_{\text{act}}}{\text{AF}_{\text{th}}} = \frac{22 \text{ kg air/kg fuel}}{16.1 \text{ kg air/kg fuel}} = 137\%$$

Thus the excess air used during this process is **37%**.

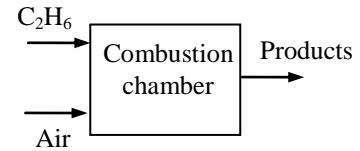

15-20 Ethane is burned with an unknown amount of air during a combustion process. The AF ratio and the percentage of theoretical air used are to be determined.

Assumptions 1 Combustion is complete. **2** The combustion products contain CO_2 , H_2O , O_2 , and N_2 only.

Properties The molar masses of C, H_2 , and air are 12 kg/kmol, 2 kg/kmol, and 29 kg/kmol, respectively (Table A-1).

Analysis (a) The combustion equation in this case can be written as

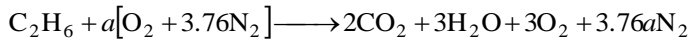

O_2 balance: $a = 2 + 1.5 + 3 \longrightarrow a = 6.5$

Substituting,

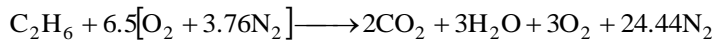

The air-fuel ratio is determined by taking the ratio of the mass of the air to the mass of the fuel,

$$\text{AF} = \frac{m_{\text{air}}}{m_{\text{fuel}}} = \frac{(6.5 \times 4.76 \text{ kmol})(29 \text{ kg/kmol})}{(2 \text{ kmol})(12 \text{ kg/kmol}) + (3 \text{ kmol})(2 \text{ kg/kmol})} = \mathbf{29.9 \text{ kg air/kg fuel}}$$

(b) To find the percent theoretical air used, we need to know the theoretical amount of air, which is determined from the theoretical combustion equation of C_2H_6 ,

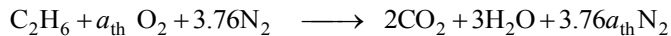

O_2 balance: $a_{\text{th}} = 2 + 1.5 \longrightarrow a_{\text{th}} = 3.5$

Then,

$$\text{Percent theoretical air} = \frac{m_{\text{air,act}}}{m_{\text{air,th}}} = \frac{N_{\text{air,act}}}{N_{\text{air,th}}} = \frac{a}{a_{\text{th}}} = \frac{6.5}{3.5} = \mathbf{186\%}$$

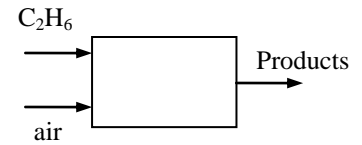

15-21E Ethylene is burned with 175 percent theoretical air during a combustion process. The AF ratio and the dew-point temperature of the products are to be determined.

Assumptions 1 Combustion is complete. **2** The combustion products contain CO_2 , H_2O , O_2 , and N_2 only. **3** Combustion gases are ideal gases.

Properties The molar masses of C, H_2 , and air are 12 lbm/lbmol, 2 lbm/lbmol, and 29 lbm/lbmol, respectively (Table A-1E).

Analysis (a) The combustion equation in this case can be written as

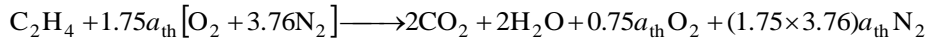

where a_{th} is the stoichiometric coefficient for air. It is determined from

$$\text{O}_2 \text{ balance: } 1.75a_{\text{th}} = 2 + 1 + 0.75a_{\text{th}} \longrightarrow a_{\text{th}} = 3$$

Substituting,

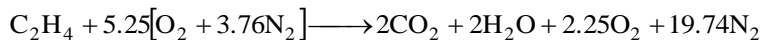

The air-fuel ratio is determined by taking the ratio of the mass of the air to the mass of the fuel,

$$\text{AF} = \frac{m_{\text{air}}}{m_{\text{fuel}}} = \frac{(5.25 \times 4.76 \text{ lbmol})(29 \text{ lbm/lbmol})}{(2 \text{ lbmol})(12 \text{ lbm/lbmol}) + (2 \text{ lbmol})(2 \text{ lbm/lbmol})} = \mathbf{25.9 \text{ lbm air/lbm fuel}}$$

(b) The dew-point temperature of a gas-vapor mixture is the saturation temperature of the water vapor in the product gases corresponding to its partial pressure. That is,

$$P_v = \left(\frac{N_v}{N_{\text{prod}}} \right) P_{\text{prod}} = \left(\frac{2 \text{ lbmol}}{25.99 \text{ lbmol}} \right) (14.5 \text{ psia}) = 1.116 \text{ psia}$$

Thus,

$$T_{\text{dp}} = T_{\text{sat}@1.116 \text{ psia}} = \mathbf{105.4^\circ\text{F}}$$

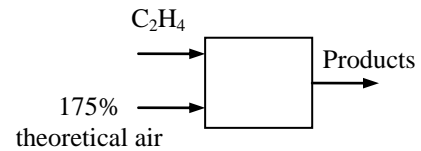

15-22 Butane is burned with air. The masses of butane and air are given. The percentage of theoretical air used and the dew-point temperature of the products are to be determined.

Assumptions 1 Combustion is complete. **2** The combustion products contain CO_2 , H_2O , and N_2 only. **3** Combustion gases are ideal gases.

Properties The molar masses of C, H_2 , and air are 12 kg/kmol, 2 kg/kmol, and 29 kg/kmol, respectively (Table A-1).

Analysis (a) The theoretical combustion equation in this case can be written as

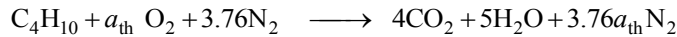

where a_{th} is the stoichiometric coefficient for air. It is determined from

$$\text{O}_2 \text{ balance: } a_{\text{th}} = 4 + 2.5 \longrightarrow a_{\text{th}} = 6.5$$

The air-fuel ratio for the theoretical reaction is determined by taking the ratio of the mass of the air to the mass of the fuel for,

$$\text{AF}_{\text{th}} = \frac{m_{\text{air,th}}}{m_{\text{fuel}}} = \frac{(6.5 \times 4.76 \text{ kmol})(29 \text{ kg/kmol})}{(4 \text{ kmol})(12 \text{ kg/kmol}) + (5 \text{ kmol})(2 \text{ kg/kmol})} = 15.5 \text{ kg air/kg fuel}$$

The actual air-fuel ratio used is

$$\text{AF}_{\text{act}} = \frac{m_{\text{air}}}{m_{\text{fuel}}} = \frac{25 \text{ kg}}{1 \text{ kg}} = 25 \text{ kg air / kg fuel}$$

Then the percent theoretical air used can be determined from

$$\text{Percent theoretical air} = \frac{\text{AF}_{\text{act}}}{\text{AF}_{\text{th}}} = \frac{25 \text{ kg air/kg fuel}}{15.5 \text{ kg air/kg fuel}} = \mathbf{161\%}$$

(b) The combustion is complete, and thus products will contain only CO_2 , H_2O , O_2 and N_2 . The air-fuel ratio for this combustion process on a mole basis is

$$\overline{\text{AF}} = \frac{N_{\text{air}}}{N_{\text{fuel}}} = \frac{m_{\text{air}} / M_{\text{air}}}{m_{\text{fuel}} / M_{\text{fuel}}} = \frac{(25 \text{ kg}) / (29 \text{ kg/kmol})}{(1 \text{ kg}) / (58 \text{ kg/kmol})} = 50 \text{ kmol air/kmol fuel}$$

Thus the combustion equation in this case can be written as

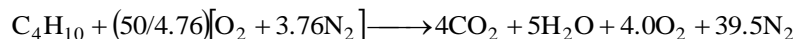

The dew-point temperature of a gas-vapor mixture is the saturation temperature of the water vapor in the product gases corresponding to its partial pressure. That is,

$$P_v = \left(\frac{N_v}{N_{\text{prod}}} \right) P_{\text{prod}} = \left(\frac{5 \text{ kmol}}{52.5 \text{ kmol}} \right) (90 \text{ kPa}) = 8.571 \text{ kPa}$$

Thus,

$$T_{\text{dp}} = T_{\text{sat}@8.571 \text{ kPa}} = \mathbf{42.8^\circ\text{C}}$$

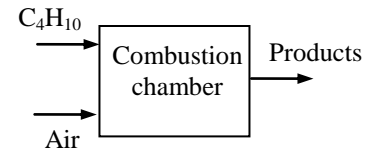

15-23E Butane is burned with air. The masses of butane and air are given. The percentage of theoretical air used and the dew-point temperature of the products are to be determined.

Assumptions 1 Combustion is complete. **2** The combustion products contain CO_2 , H_2O , and N_2 only. **3** Combustion gases are ideal gases.

Properties The molar masses of C, H_2 , and air are 12 lbm/lbmol, 2 lbm/lbmol, and 29 lbm/lbmol, respectively (Table A-1).

Analysis (a) The theoretical combustion equation in this case can be written as

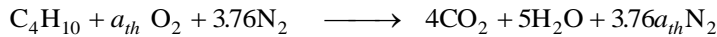

where a_{th} is the stoichiometric coefficient for air. It is determined from

$$\text{O}_2 \text{ balance: } a_{\text{th}} = 4 + 2.5 \longrightarrow a_{\text{th}} = 6.5$$

The air-fuel ratio for the theoretical reaction is determined by taking the ratio of the mass of the air to the mass of the fuel for,

$$\text{AF}_{\text{th}} = \frac{m_{\text{air,th}}}{m_{\text{fuel}}} = \frac{(6.5 \times 4.76 \text{ lbmol})(29 \text{ lbm/lbmol})}{(4 \text{ lbmol})(12 \text{ lbm/lbmol}) + (5 \text{ lbmol})(2 \text{ lbm/lbmol})} = 15.5 \text{ lbm air/lbm fuel}$$

The actual air-fuel ratio used is

$$\text{AF}_{\text{act}} = \frac{m_{\text{air}}}{m_{\text{fuel}}} = \frac{25 \text{ lbm}}{1 \text{ lbm}} = 25 \text{ lbm air/lbm fuel}$$

Then the percent theoretical air used can be determined from

$$\text{Percent theoretical air} = \frac{\text{AF}_{\text{act}}}{\text{AF}_{\text{th}}} = \frac{25 \text{ lbm air/lbm fuel}}{15.5 \text{ lbm air/lbm fuel}} = \mathbf{161\%}$$

(b) The combustion is complete, and thus products will contain only CO_2 , H_2O , O_2 and N_2 . The air-fuel ratio for this combustion process on a mole basis is

$$\overline{\text{AF}} = \frac{N_{\text{air}}}{N_{\text{fuel}}} = \frac{m_{\text{air}} / M_{\text{air}}}{m_{\text{fuel}} / M_{\text{fuel}}} = \frac{(25 \text{ lbm}) / (29 \text{ lbm/lbmol})}{(1 \text{ lbm}) / (58 \text{ lbm/lbmol})} = 50 \text{ lbmol air/lbmol fuel}$$

Thus the combustion equation in this case can be written as

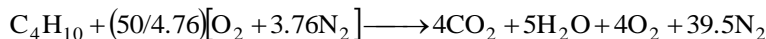

The dew-point temperature of a gas-vapor mixture is the saturation temperature of the water vapor in the product gases corresponding to its partial pressure. That is,

$$P_v = \left(\frac{N_v}{N_{\text{prod}}} \right) P_{\text{prod}} = \left(\frac{5 \text{ lbmol}}{52.5 \text{ lbmol}} \right) (14.7 \text{ psia}) = 1.4 \text{ psia}$$

Thus,

$$T_{\text{dp}} = T_{\text{sat}@1.4 \text{ psia}} = \mathbf{113.2^\circ\text{F}}$$

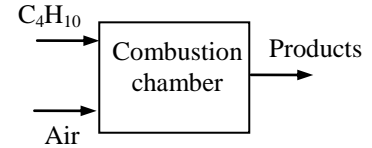

15-24 Butane C_4H_{10} is burned with 200 percent theoretical air. The kmol of water that needs to be sprayed into the combustion chamber per kmol of fuel is to be determined.

Assumptions 1 Combustion is complete. **2** The combustion products contain CO_2 , H_2O , O_2 , and N_2 only.

Properties The molar masses of C, H_2 , O_2 and air are 12 kg/kmol, 2 kg/kmol, 32 kg/kmol, and 29 kg/kmol, respectively (Table A-1).

Analysis The reaction equation for 200% theoretical air without the additional water is

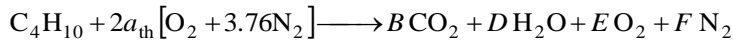

where a_{th} is the stoichiometric coefficient for air. We have automatically accounted for the 100% excess air by using the factor $2a_{th}$ instead of a_{th} for air. The coefficient a_{th} and other coefficients are to be determined from the mass balances

Carbon balance: $B = 4$

Hydrogen balance: $2D = 10 \longrightarrow D = 5$

Oxygen balance: $2 \times 2a_{th} = 2B + D + 2E$

$$a_{th} = E$$

Nitrogen balance: $2a_{th} \times 3.76 = F$

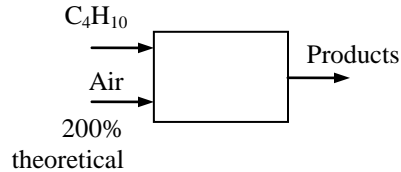

Solving the above equations, we find the coefficients ($E = 6.5$, $F = 48.88$, and $a_{th} = 6.5$) and write the balanced reaction equation as

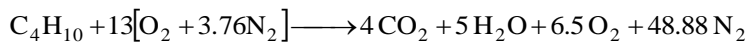

With the additional water sprayed into the combustion chamber, the balanced reaction equation is

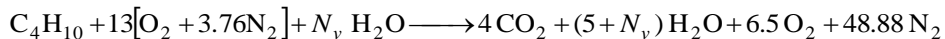

The partial pressure of water in the saturated product mixture at the dew point is

$$P_{v,prod} = P_{sat @ 50^\circ C} = 12.35 \text{ kPa}$$

The vapor mole fraction is

$$y_v = \frac{P_{v,prod}}{P_{prod}} = \frac{12.35 \text{ kPa}}{100 \text{ kPa}} = 0.1235$$

The amount of water that needs to be sprayed into the combustion chamber can be determined from

$$y_v = \frac{N_{water}}{N_{total,product}} \longrightarrow 0.1235 = \frac{5 + N_v}{4 + 5 + N_v + 6.5 + 48.88} \longrightarrow N_v = \mathbf{3.37 \text{ kmol}}$$

15-25 A fuel mixture of 60% by mass methane, CH_4 , and 40% by mass ethanol, $\text{C}_2\text{H}_6\text{O}$, is burned completely with theoretical air. The required flow rate of air is to be determined.

Assumptions 1 Combustion is complete. **2** The combustion products contain CO_2 , H_2O , and N_2 only.

Properties The molar masses of C, H_2 , O_2 and air are 12 kg/kmol, 2 kg/kmol, 32 kg/kmol, and 29 kg/kmol, respectively (Table A-1).

Analysis For 100 kg of fuel mixture, the mole numbers are

$$N_{\text{CH}_4} = \frac{mf_{\text{CH}_4}}{M_{\text{CH}_4}} = \frac{60 \text{ kg}}{16 \text{ kg/kmol}} = 3.75 \text{ kmol}$$

$$N_{\text{C}_2\text{H}_6\text{O}} = \frac{mf_{\text{C}_2\text{H}_6\text{O}}}{M_{\text{C}_2\text{H}_6\text{O}}} = \frac{40 \text{ kg}}{46 \text{ kg/kmol}} = 0.8696 \text{ kmol}$$

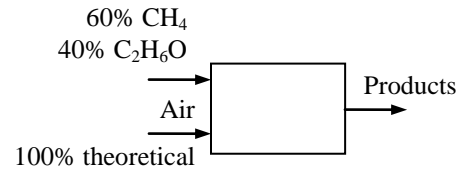

The mole fraction of methane and ethanol in the fuel mixture are

$$x = \frac{N_{\text{CH}_4}}{N_{\text{CH}_4} + N_{\text{C}_2\text{H}_6\text{O}}} = \frac{3.75 \text{ kmol}}{(3.75 + 0.8696) \text{ kmol}} = 0.8118$$

$$y = \frac{N_{\text{C}_2\text{H}_6\text{O}}}{N_{\text{CH}_4} + N_{\text{C}_2\text{H}_6\text{O}}} = \frac{0.8696 \text{ kmol}}{(3.75 + 0.8696) \text{ kmol}} = 0.1882$$

The combustion equation in this case can be written as

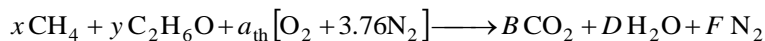

where a_{th} is the stoichiometric coefficient for air. The coefficient a_{th} and other coefficients are to be determined from the mass balances

$$\begin{aligned} \text{Carbon balance:} \quad & x + 2y = B \\ \text{Hydrogen balance:} \quad & 4x + 6y = 2D \\ \text{Oxygen balance:} \quad & 2a_{\text{th}} + y = 2B + D \\ \text{Nitrogen balance:} \quad & 3.76a_{\text{th}} = F \end{aligned}$$

Substituting x and y values into the equations and solving, we find the coefficients as

$$\begin{aligned} x &= 0.8118 & B &= 1.188 \\ y &= 0.1882 & D &= 2.188 \\ a_{\text{th}} &= 2.188 & F &= 8.228 \end{aligned}$$

Then, we write the balanced reaction equation as

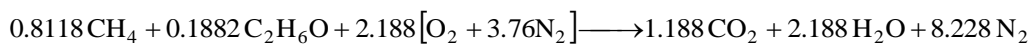

The air-fuel ratio is determined by taking the ratio of the mass of the air to the mass of the fuel,

$$\begin{aligned} \text{AF} &= \frac{m_{\text{air}}}{m_{\text{fuel}}} = \frac{(2.188 \times 4.76 \text{ kmol})(29 \text{ kg/kmol})}{(0.8118 \text{ kmol})(12 + 4 \times 1) \text{ kg/kmol} + (0.1882 \text{ kmol})(2 \times 12 + 6 \times 1 + 16) \text{ kg/kmol}} \\ &= 13.94 \text{ kg air/kg fuel} \end{aligned}$$

Then, the required flow rate of air becomes

$$\dot{m}_{\text{air}} = \text{AF} \dot{m}_{\text{fuel}} = (13.94)(10 \text{ kg/s}) = \mathbf{139.4 \text{ kg/s}}$$

15-26 The volumetric fractions of the constituents of a certain natural gas are given. The AF ratio is to be determined if this gas is burned with the stoichiometric amount of dry air.

Assumptions 1 Combustion is complete. **2** The combustion products contain CO_2 , H_2O , and N_2 only.

Properties The molar masses of C, H_2 , N_2 , O_2 , and air are 12 kg/kmol, 2 kg/kmol, 28 kg/kmol, 32 kg/kmol, and 29 kg/kmol, respectively (Table A-1).

Analysis Considering 1 kmol of fuel, the combustion equation can be written as

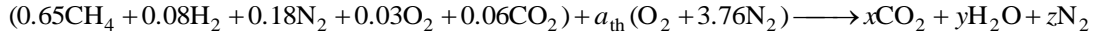

The unknown coefficients in the above equation are determined from mass balances,

$$\text{C: } 0.65 + 0.06 = x \quad \longrightarrow x = 0.71$$

$$\text{H: } 0.65 \times 4 + 0.08 \times 2 = 2y \quad \longrightarrow y = 1.38$$

$$\text{O}_2: 0.03 + 0.06 + a_{\text{th}} = x + y/2 \quad \longrightarrow a_{\text{th}} = 1.31$$

$$\text{N}_2: 0.18 + 3.76a_{\text{th}} = z \quad \longrightarrow z = 5.106$$

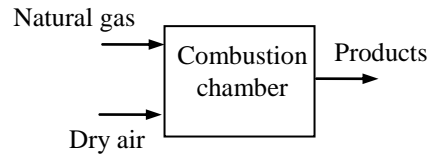

Thus,

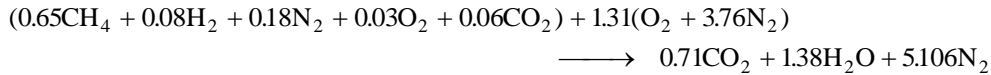

The air-fuel ratio for this reaction is determined by taking the ratio of the mass of the air to the mass of the fuel,

$$m_{\text{air}} = (1.31 \times 4.76 \text{ kmol})(29 \text{ kg/kmol}) = 180.8 \text{ kg}$$

$$m_{\text{fuel}} = (0.65 \times 16 + 0.08 \times 2 + 0.18 \times 28 + 0.03 \times 32 + 0.06 \times 44) \text{ kg} = 19.2 \text{ kg}$$

and

$$\text{AF}_{\text{th}} = \frac{m_{\text{air,th}}}{m_{\text{fuel}}} = \frac{180.8 \text{ kg}}{19.2 \text{ kg}} = \mathbf{9.42 \text{ kg air/kg fuel}}$$

15-27 The composition of a certain natural gas is given. The gas is burned with stoichiometric amount of moist air. The AF ratio is to be determined.

Assumptions 1 Combustion is complete. **2** The combustion products contain CO_2 , H_2O , and N_2 only.

Properties The molar masses of C, H_2 , N_2 , O_2 , and air are 12 kg/kmol, 2 kg/kmol, 28 kg/kmol, 32 kg/kmol, and 29 kg/kmol, respectively (Table A-1).

Analysis The fuel is burned completely with the stoichiometric amount of air, and thus the products will contain only H_2O , CO_2 and N_2 , but no free O_2 . The moisture in the air does not react with anything; it simply shows up as additional H_2O in the products. Therefore, we can simply balance the combustion equation using dry air, and then add the moisture to both sides of the equation. Considering 1 kmol of fuel, the combustion equation can be written as

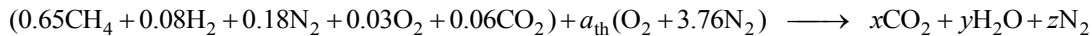

The unknown coefficients in the above equation are determined from mass balances,

$$\text{C: } 0.65 + 0.06 = x \longrightarrow x = 0.71$$

$$\text{H: } 0.65 \times 4 + 0.08 \times 2 = 2y \longrightarrow y = 1.38$$

$$\text{O}_2: 0.03 + 0.06 + a_{\text{th}} = x + y/2 \longrightarrow a_{\text{th}} = 1.31$$

$$\text{N}_2: 0.18 + 3.76a_{\text{th}} = z \longrightarrow z = 5.106$$

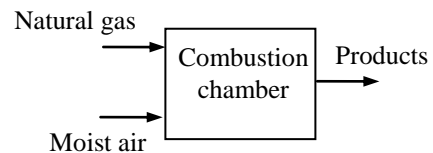

Thus,

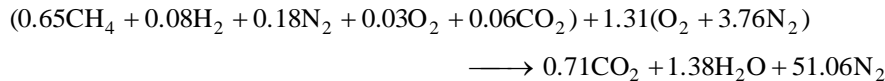

Next we determine the amount of moisture that accompanies $4.76a_{\text{th}} = (4.76)(1.31) = 6.24$ kmol of dry air. The partial pressure of the moisture in the air is

$$P_{v,\text{in}} = \phi_{\text{air}} P_{\text{sat}@25^\circ\text{C}} = (0.70)(3.1698 \text{ kPa}) = 2.219 \text{ kPa}$$

Assuming ideal gas behavior, the number of moles of the moisture in the air ($N_{v,\text{in}}$) is determined to be

$$N_{v,\text{in}} = \left(\frac{P_{v,\text{in}}}{P_{\text{total}}} \right) N_{\text{total}} = \left(\frac{2.219 \text{ kPa}}{101.325 \text{ kPa}} \right) (6.24 + N_{v,\text{in}}) \longrightarrow N_{v,\text{air}} = 0.1396 \text{ kmol}$$

The balanced combustion equation is obtained by substituting the coefficients determined earlier and adding 0.17 kmol of H_2O to both sides of the equation,

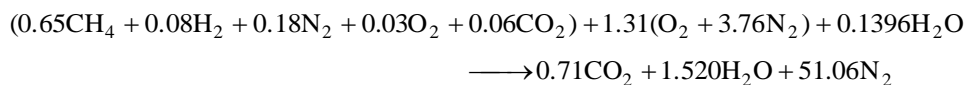

The air-fuel ratio for this reaction is determined by taking the ratio of the mass of the air to the mass of the fuel,

$$m_{\text{air}} = (1.31 \times 4.76 \text{ kmol})(29 \text{ kg/kmol}) + (0.1396 \text{ kmol} \times 18 \text{ kg/kmol}) = 183.3 \text{ kg}$$

$$m_{\text{fuel}} = (0.65 \times 16 + 0.08 \times 2 + 0.18 \times 28 + 0.03 \times 32 + 0.06 \times 44) \text{ kg} = 19.20 \text{ kg}$$

and

$$\text{AF}_{\text{th}} = \frac{m_{\text{air,th}}}{m_{\text{fuel}}} = \frac{183.3 \text{ kg}}{19.20 \text{ kg}} = \mathbf{9.55 \text{ kg air/kg fuel}}$$

15-28 The composition of a gaseous fuel is given. It is burned with 130 percent theoretical air. The AF ratio and the fraction of water vapor that would condense if the product gases were cooled are to be determined.

Assumptions 1 Combustion is complete. **2** The combustion products contain CO_2 , H_2O , O_2 , and N_2 only.

Properties The molar masses of C, H_2 , N_2 , and air are 12 kg/kmol, 2 kg/kmol, 28 kg/kmol, and 29 kg/kmol, respectively (Table A-1).

Analysis (a) The fuel is burned completely with excess air, and thus the products will contain H_2O , CO_2 , N_2 , and some free O_2 . Considering 1 kmol of fuel, the combustion equation can be written as

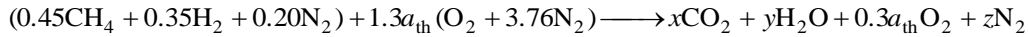

The unknown coefficients in the above equation are determined from mass balances,

$$\text{C: } 0.45 = x \quad \longrightarrow x = 0.45$$

$$\text{H: } 0.45 \times 4 + 0.35 \times 2 = 2y \quad \longrightarrow y = 1.2$$

$$\text{O}_2: 1.3a_{\text{th}} = x + y/2 + 0.3a_{\text{th}} \quad \longrightarrow a_{\text{th}} = 1.05$$

$$\text{N}_2: 0.20 + 3.76 \times 1.3a_{\text{th}} = z \quad \longrightarrow z = 5.332$$

Thus,

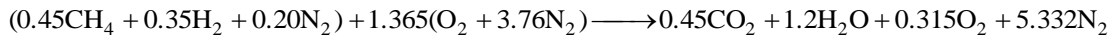

The air-fuel ratio for the this reaction is determined by taking the ratio of the mass of the air to the mass of the fuel,

$$m_{\text{air}} = (1.365 \times 4.76 \text{ kmol})(29 \text{ kg/kmol}) = 188.4 \text{ kg}$$

$$m_{\text{fuel}} = (0.45 \times 16 + 0.35 \times 2 + 0.2 \times 28) \text{ kg} = 13.5 \text{ kg}$$

and

$$\text{AF} = \frac{m_{\text{air}}}{m_{\text{fuel}}} = \frac{188.4 \text{ kg}}{13.5 \text{ kg}} = \mathbf{13.96 \text{ kg air/kg fuel}}$$

(b) For each kmol of fuel burned, $0.45 + 1.2 + 0.315 + 5.332 = 7.297$ kmol of products are formed, including 1.2 kmol of H_2O . Assuming that the dew-point temperature of the products is above 25°C , some of the water vapor will condense as the products are cooled to 25°C . If N_w kmol of H_2O condenses, there will be $1.2 - N_w$ kmol of water vapor left in the products. The mole number of the products in the gas phase will also decrease to $7.297 - N_w$ as a result. Treating the product gases (including the remaining water vapor) as ideal gases, N_w is determined by equating the mole fraction of the water vapor to its pressure fraction,

$$\frac{N_w}{N_{\text{prod gas}}} = \frac{P_w}{P_{\text{prod}}} \longrightarrow \frac{1.2 - N_w}{7.297 - N_w} = \frac{3.1698 \text{ kPa}}{101.325 \text{ kPa}} \longrightarrow N_w = 1.003 \text{ kmol}$$

since $P_w = P_{\text{sat}} @ 25^\circ\text{C} = 3.1698 \text{ kPa}$. Thus the fraction of water vapor that condenses is

$$1.003/1.2 = 0.836 \text{ or } \mathbf{84\%}.$$

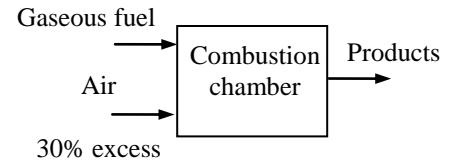



15-29 Problem 15-28 is reconsidered. The effects of varying the percentages of CH₄, H₂ and N₂ making up the fuel and the product gas temperature are to be studied.

Analysis The problem is solved using EES, and the solution is given below.

Let's modify this problem to include the fuels butane, ethane, methane, and propane in pull down menu. Adiabatic Combustion of fuel C_nH_m entering at T_{fuel} with Stoichiometric Air at T_{air}:
 Reaction: $aC_xH_y + bH_2 + cN_2 + (a*y/4 + a*x + b/2) (Theo_air/100) (O_2 + 3.76 N_2)$
 $\leftrightarrow a*xCO_2 + ((a*y/2) + b) H_2O + (c + 3.76 (a*y/4 + a*x + b/2) (Theo_air/100)) N_2 + (a*y/4 + a*x + b/2) (Theo_air/100 - 1) O_2$

T_{prod} is the product gas temperature.

Theo_{air} is the % theoretical air. "

Procedure

H2OCond(P_{prod}, T_{prod}, Moles_{H2O}, M_{other}: T_{DewPoint}, Moles_{H2O_vap}, Moles_{H2O_liq}, Result\$)

P_v = Moles_{H2O} / (M_{other} + Moles_{H2O}) * P_{prod}

T_{DewPoint} = temperature(steam, P = P_v, x = 0)

IF T_{DewPoint} <= T_{prod} then

Moles_{H2O_vap} = Moles_{H2O}

Moles_{H2O_liq} = 0

Result\$ = 'No condensation occurred'

ELSE

P_{v_new} = pressure(steam, T = T_{prod}, x = 0)

Moles_{H2O_vap} = P_{v_new} / P_{prod} * M_{other} / (1 - P_{v_new} / P_{prod})

Moles_{H2O_liq} = Moles_{H2O} - Moles_{H2O_vap}

Result\$ = 'There is condensation'

ENDIF

END

"Input data from the diagram window"

{P_{prod} = 101.325 [kPa]

Theo_{air} = 130 [%]"

a = 0.45

b = 0.35

c = 0.20

T_{prod} = 25 [C]

Fuel\$ = 'CH₄'

x = 1

y = 4

"Composition of Product gases:"

A_{th} = a*y/4 + a*x + b/2

AF_{ratio} = 4.76*A_{th}*Theo_{air}/100*molarmass(Air)/(a*16 + b*2 + c*28) "[kg_{air}/kg_{fuel}]"

Moles_{O2} = (a*y/4 + a*x + b/2) * (Theo_{air}/100 - 1)

Moles_{N2} = c + (3.76*(a*y/4 + a*x + b/2)) * (Theo_{air}/100)

Moles_{CO2} = a*x

Moles_{H2O} = a*y/2 + b

M_{other} = Moles_{O2} + Moles_{N2} + Moles_{CO2}

Call H2OCond(P_{prod}, T_{prod}, Moles_{H2O}, M_{other}: T_{DewPoint}, Moles_{H2O_vap}, Moles_{H2O_liq}, Result\$)

Frac_{cond} = Moles_{H2O_liq} / Moles_{H2O} * Convert(, %) "[%]"

"Reaction: aC_xH_y + bH₂ + cN₂ + A_{th}Theo_{air}/100 (O₂ + 3.76 N₂)

$\leftrightarrow a*xCO_2 + (a*y/2 + b) H_2O + (c + 3.76 A_{th} Theo_{air}/100) N_2 + A_{th} (Theo_{air}/100 - 1) O_2$ "

AF _{ratio} [kg _{air} / kg _{fuel}]	Frac _{cond} [%]	Moles _{H₂O,liq}	Moles _{H₂O,vap}	T _{prod} [C]
14.27	95.67	1.196	0.05409	5
14.27	93.16	1.165	0.08549	11.67
14.27	89.42	1.118	0.1323	18.33
14.27	83.92	1.049	0.201	25
14.27	75.94	0.9492	0.3008	31.67
14.27	64.44	0.8055	0.4445	38.33
14.27	47.92	0.599	0.651	45
14.27	24.06	0.3008	0.9492	51.67
14.27	0	0	1.25	58.33
14.27	0	0	1.25	65
14.27	0	0	1.25	71.67
14.27	0	0	1.25	78.33
14.27	0	0	1.25	85

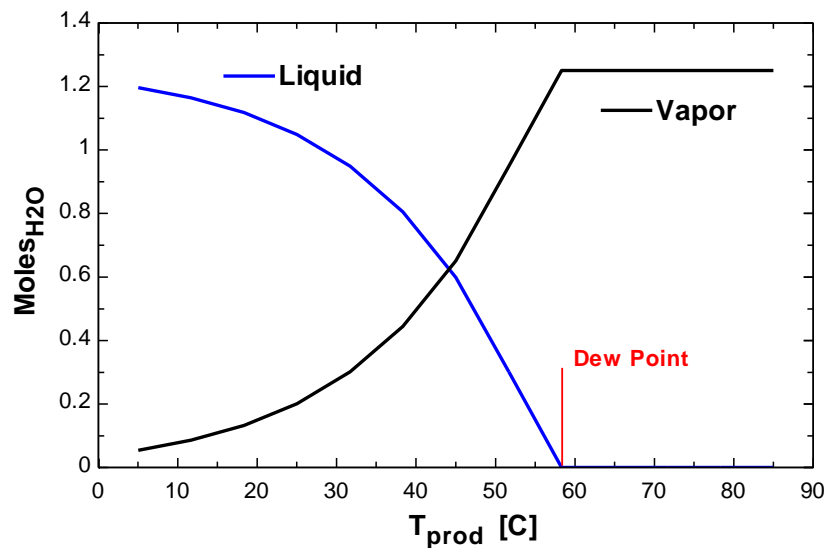

15-30 Methane is burned with dry air. The volumetric analysis of the products is given. The AF ratio and the percentage of theoretical air used are to be determined.

Assumptions 1 Combustion is complete. **2** The combustion products contain CO_2 , CO , H_2O , O_2 , and N_2 only.

Properties The molar masses of C, H_2 , and air are 12 kg/kmol, 2 kg/kmol, and 29 kg/kmol, respectively (Table A-1).

Analysis Considering 100 kmol of dry products, the combustion equation can be written as

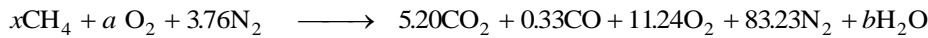

The unknown coefficients x , a , and b are determined from mass balances,

$$\text{N}_2 : 3.76a = 83.23 \longrightarrow a = 22.14$$

$$\text{C} : x = 5.20 + 0.33 \longrightarrow x = 5.53$$

$$\text{H} : 4x = 2b \longrightarrow b = 11.06$$

$$(\text{Check } \text{O}_2 : a = 5.20 + 0.165 + 11.24 + b/2 \longrightarrow 22.14 = 22.14)$$

Thus,



The combustion equation for 1 kmol of fuel is obtained by dividing the above equation by 5.53,



(a) The air-fuel ratio is determined from its definition,

$$\text{AF} = \frac{m_{\text{air}}}{m_{\text{fuel}}} = \frac{(4.0 \times 4.76 \text{ kmol})(29 \text{ kg/kmol})}{(1 \text{ kmol})(12 \text{ kg/kmol}) + (2 \text{ kmol})(2 \text{ kg/kmol})} = \mathbf{34.5 \text{ kg air/kg fuel}}$$

(b) To find the percent theoretical air used, we need to know the theoretical amount of air, which is determined from the theoretical combustion equation of the fuel,

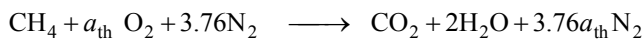

$$\text{O}_2 : a_{\text{th}} = 1 + 1 \longrightarrow a_{\text{th}} = 2.0$$

Then,

$$\text{Percent theoretical air} = \frac{m_{\text{air,act}}}{m_{\text{air,th}}} = \frac{N_{\text{air,act}}}{N_{\text{air,th}}} = \frac{(4.0)(4.76) \text{ kmol}}{(2.0)(4.76) \text{ kmol}} = \mathbf{200\%}$$

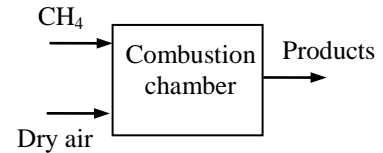

15-31 Octane is burned with dry air. The volumetric fractions of the products are given. The AF ratio and the percentage of theoretical air used are to be determined.

Assumptions 1 Combustion is complete. **2** The combustion products contain CO_2 , CO , H_2O , O_2 , and N_2 only.

Properties The molar masses of C, H_2 , and air are 12 kg/kmol, 2 kg/kmol, and 29 kg/kmol, respectively (Table A-1).

Analysis Considering 100 kmol of dry products, the combustion equation can be written as



The unknown coefficients x , a , and b are determined from mass balances,

$$\text{N}_2 : 3.76a = 83.12 \longrightarrow a = 22.11$$

$$\text{C} : 8x = 9.21 + 0.61 \longrightarrow x = 1.23$$

$$\text{H} : 18x = 2b \longrightarrow b = 11.07$$

$$(\text{Check } \text{O}_2 : a = 9.21 + 0.305 + 7.06 + b/2 \longrightarrow 22.11 \cong 22.10)$$

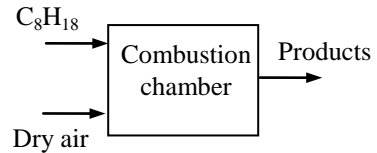

Thus,



The combustion equation for 1 kmol of fuel is obtained by dividing the above equation by 1.23,

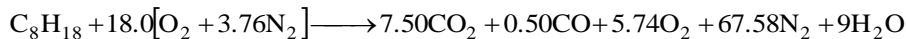

(a) The air-fuel ratio is determined by taking the ratio of the mass of the air to the mass of the fuel,

$$\text{AF} = \frac{m_{\text{air}}}{m_{\text{fuel}}} = \frac{(18.0 \times 4.76 \text{ kmol})(29 \text{ kg/kmol})}{(8 \text{ kmol})(12 \text{ kg/kmol}) + (9 \text{ kmol})(2 \text{ kg/kmol})} = \mathbf{21.8 \text{ kg air/kg fuel}}$$

(b) To find the percent theoretical air used, we need to know the theoretical amount of air, which is determined from the theoretical combustion equation of the fuel,

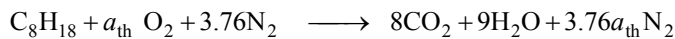

$$\text{O}_2 : a_{\text{th}} = 8 + 4.5 \longrightarrow a_{\text{th}} = 12.5$$

Then,

$$\text{Percent theoretical air} = \frac{m_{\text{air,act}}}{m_{\text{air,th}}} = \frac{N_{\text{air,act}}}{N_{\text{air,th}}} = \frac{(18.0)(4.76) \text{ kmol}}{(12.5)(4.76) \text{ kmol}} = \mathbf{144\%}$$

15-32 n-Octane is burned with 60% excess air. The combustion is incomplete. The mole fractions of products and the dew-point temperature of the water vapor in the products are to be determined.

Assumptions 1 Combustion is complete. 2 The combustion products contain CO_2 , CO , H_2O , O_2 , and N_2 only.

Properties The molar masses of C, H_2 , O_2 , N_2 and air are 12 kg/kmol, 2 kg/kmol, 32 kg/kmol, 28 kg/kmol, and 29 kg/kmol, respectively (Table A-1).

Analysis The combustion reaction for stoichiometric air is

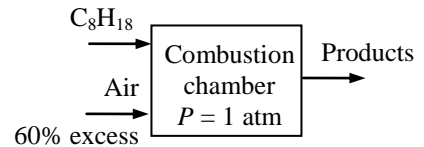
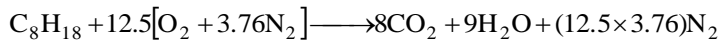

The combustion equation with 60% excess air and incomplete combustion is

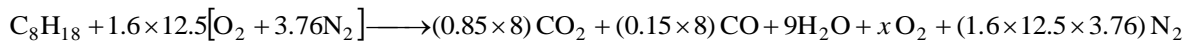

The coefficient for CO is determined from a mass balance,

$$\text{O}_2 \text{ balance: } 1.6 \times 12.5 = 0.85 \times 8 + 0.5 \times 0.15 \times 8 + 0.5 \times 9 + x \longrightarrow x = 8.100$$

Substituting,

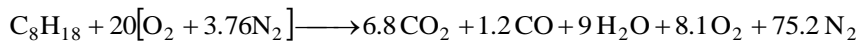

The mole fractions of the products are

$$N_{\text{prod}} = 6.8 + 1.2 + 9 + 8.1 + 75.2 = 100.3 \text{ kmol}$$

$$y_{\text{CO}_2} = \frac{N_{\text{CO}_2}}{N_{\text{prod}}} = \frac{6.8 \text{ kmol}}{100.3 \text{ kmol}} = \mathbf{0.0678}$$

$$y_{\text{CO}} = \frac{N_{\text{CO}}}{N_{\text{prod}}} = \frac{1.2 \text{ kmol}}{100.3 \text{ kmol}} = \mathbf{0.0120}$$

$$y_{\text{H}_2\text{O}} = \frac{N_{\text{H}_2\text{O}}}{N_{\text{prod}}} = \frac{9 \text{ kmol}}{100.3 \text{ kmol}} = \mathbf{0.0897}$$

$$y_{\text{O}_2} = \frac{N_{\text{O}_2}}{N_{\text{prod}}} = \frac{8.1 \text{ kmol}}{100.3 \text{ kmol}} = \mathbf{0.0808}$$

$$y_{\text{N}_2} = \frac{N_{\text{N}_2}}{N_{\text{prod}}} = \frac{75.2 \text{ kmol}}{100.3 \text{ kmol}} = \mathbf{0.7498}$$

The dew-point temperature of a gas-vapor mixture is the saturation temperature of the water vapor in the product gases corresponding to its partial pressure. That is,

$$P_v = \left(\frac{N_v}{N_{\text{prod}}} \right) P_{\text{prod}} = \left(\frac{9 \text{ kmol}}{100.3 \text{ kmol}} \right) (101.325 \text{ kPa}) = 9.092 \text{ kPa}$$

Thus,

$$T_{\text{dp}} = T_{\text{sat}@9.092\text{kPa}} = \mathbf{44.0^\circ\text{C}} \quad (\text{Table A-5 or EES})$$

15-33 Methyl alcohol is burned with 100% excess air. The combustion is incomplete. The balanced chemical reaction is to be written and the air-fuel ratio is to be determined.

Assumptions 1 Combustion is incomplete. 2 The combustion products contain CO_2 , CO , H_2O , O_2 , and N_2 only.

Properties The molar masses of C, H_2 , O_2 , N_2 and air are 12 kg/kmol, 2 kg/kmol, 32 kg/kmol, 28 kg/kmol, and 29 kg/kmol, respectively (Table A-1).

Analysis The balanced reaction equation for stoichiometric air is

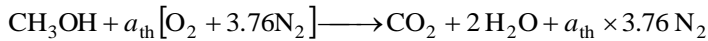

The stoichiometric coefficient a_{th} is determined from an O_2 balance:

$$0.5 + a_{\text{th}} = 1 + 1 \longrightarrow a_{\text{th}} = 1.5$$

Substituting,

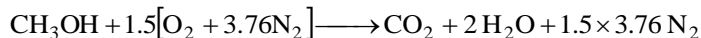

The reaction with 100% excess air and incomplete combustion can be written as

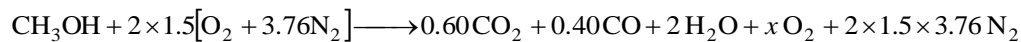

The coefficient for O_2 is determined from a mass balance,

$$\text{O}_2 \text{ balance: } 0.5 + 2 \times 1.5 = 0.6 + 0.2 + 1 + x \longrightarrow x = 1.7$$

Substituting,

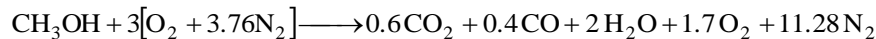

The air-fuel mass ratio is

$$\text{AF} = \frac{m_{\text{air}}}{m_{\text{fuel}}} = \frac{(3 \times 4.76 \times 29) \text{ kg}}{(1 \times 32) \text{ kg}} = \frac{414.1 \text{ kg}}{32 \text{ kg}} = \mathbf{12.94 \text{ kg air/kg fuel}}$$

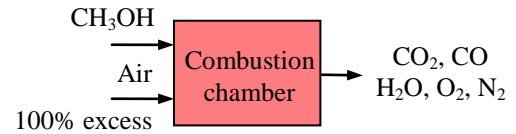

15-34 Ethyl alcohol is burned with stoichiometric amount of air. The combustion is incomplete. The apparent molecular weight of the products is to be determined.

Assumptions 1 Combustion is complete. 2 The combustion products contain CO_2 , CO , H_2O , OH , and N_2 only.

Properties The molar masses of C, H_2 , OH , N_2 and air are 12 kg/kmol, 2 kg/kmol, 17 kg/kmol, 28 kg/kmol, and 29 kg/kmol, respectively (Table A-1).

Analysis The reaction with stoichiometric air is

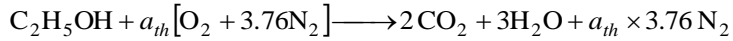

where

$$0.5 + a_{th} = 2 + 1.5 \longrightarrow a_{th} = 3$$

Substituting,

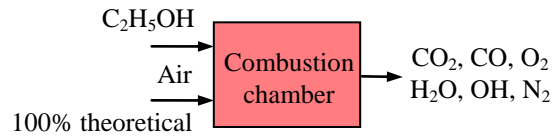
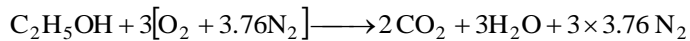

The balanced reaction equation with incomplete combustion is

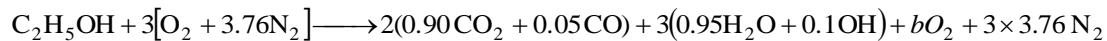

$$\text{O}_2 \text{ balance: } 0.5 + 3 = 1.8 + 0.05 + 3.15/2 + b \rightarrow b = 0.075$$

which can be written as

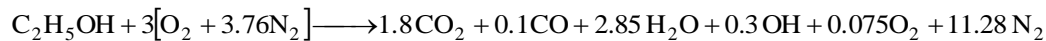

The total moles of the products is

$$N_m = 1.8 + 0.1 + 2.85 + 0.3 + 0.075 + 11.28 = 16.41 \text{ kmol}$$

The apparent molecular weight of the product gas is

$$M_m = \frac{m_m}{N_m} = \frac{(1.8 \times 44 + 0.1 \times 28 + 2.85 \times 18 + 0.3 \times 17 + 0.075 \times 32 + 11.28 \times 28) \text{ kg}}{16.41 \text{ kmol}} = \mathbf{27.84 \text{ kg/kmol}}$$

15-35 Coal whose mass percentages are specified is burned with 40% excess air. The air-fuel ratio and the apparent molecular weight of the product gas are to be determined.

Assumptions 1 Combustion is complete. **2** The combustion products contain CO_2 , CO , H_2O , SO_2 , and N_2 . **3** Combustion gases are ideal gases.

Properties The molar masses of C, H_2 , O_2 , S, and air are 12, 2, 32, 32, and 29 kg/kmol, respectively (Table A-1).

Analysis We consider 100 kg of coal for simplicity. Noting that the mass percentages in this case correspond to the masses of the constituents, the mole numbers of the constituent of the coal are determined to be

$$N_{\text{C}} = \frac{m_{\text{C}}}{M_{\text{C}}} = \frac{67.40 \text{ kg}}{12 \text{ kg/kmol}} = 5.617 \text{ kmol}$$

$$N_{\text{H}_2} = \frac{m_{\text{H}_2}}{M_{\text{H}_2}} = \frac{5.31 \text{ kg}}{2 \text{ kg/kmol}} = 2.655 \text{ kmol}$$

$$N_{\text{O}_2} = \frac{m_{\text{O}_2}}{M_{\text{O}_2}} = \frac{15.11 \text{ kg}}{32 \text{ kg/kmol}} = 0.4722 \text{ kmol}$$

$$N_{\text{N}_2} = \frac{m_{\text{N}_2}}{M_{\text{N}_2}} = \frac{1.44 \text{ kg}}{28 \text{ kg/kmol}} = 0.05143 \text{ kmol}$$

$$N_{\text{S}} = \frac{m_{\text{S}}}{M_{\text{S}}} = \frac{2.36 \text{ kg}}{32 \text{ kg/kmol}} = 0.07375 \text{ kmol}$$

67.40% C
5.31% H_2
15.11% O_2
1.44% N_2
2.36% S
8.38% ash (by mass)

The mole number of the mixture and the mole fractions are

$$N_m = 5.617 + 2.655 + 0.4722 + 0.05143 + 0.07375 = 8.869 \text{ kmol}$$

$$y_{\text{C}} = \frac{N_{\text{C}}}{N_m} = \frac{5.617 \text{ kmol}}{8.869 \text{ kmol}} = 0.6333$$

$$y_{\text{H}_2} = \frac{N_{\text{H}_2}}{N_m} = \frac{2.655 \text{ kmol}}{8.869 \text{ kmol}} = 0.2994$$

$$y_{\text{O}_2} = \frac{N_{\text{O}_2}}{N_m} = \frac{0.4722 \text{ kmol}}{8.869 \text{ kmol}} = 0.05323$$

$$y_{\text{N}_2} = \frac{N_{\text{N}_2}}{N_m} = \frac{0.05143 \text{ kmol}}{8.869 \text{ kmol}} = 0.00580$$

$$y_{\text{S}} = \frac{N_{\text{S}}}{N_m} = \frac{0.07375 \text{ kmol}}{8.869 \text{ kmol}} = 0.00832$$

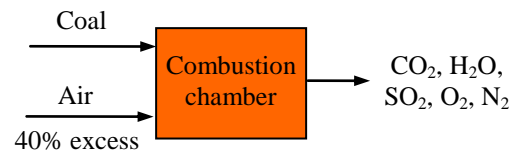

Ash consists of the non-combustible matter in coal. Therefore, the mass of ash content that enters the combustion chamber is equal to the mass content that leaves. Disregarding this non-reacting component for simplicity, the combustion equation may be written as

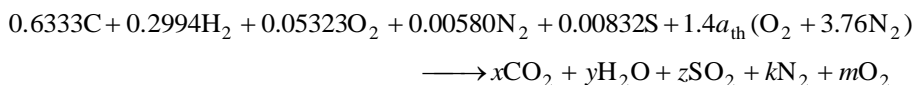

According to the species balances,

$$\text{C balance : } x = 0.6333$$

$$\text{H}_2 \text{ balance : } y = 0.2994$$

$$\text{S balance : } z = 0.00832$$

$$\text{O}_2 \text{ balance :}$$

$$0.05323 + a_{\text{th}} = x + 0.5y + z$$

$$a_{\text{th}} = 0.6333 + 0.5 \times 0.2994 + 0.00832 - 0.05323 = 0.7381$$

$$\text{N}_2 \text{ balance : } k = 0.00580 + 1.4 \times 3.76a_{\text{th}} = 0.00580 + 1.4 \times 3.76 \times 0.7381 = 3.891$$

$$m = 0.4a_{\text{th}} = 0.4 \times 0.7381 = 0.2952$$

Substituting,

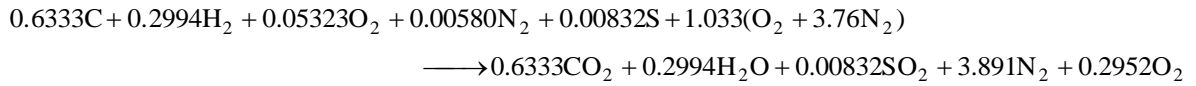

The total mass of the products is

$$m_{\text{total}} = 0.6333 \times 44 + 0.2994 \times 18 + 0.00832 \times 64 + 3.891 \times 28 + 0.2952 \times 32 = 152.2 \text{ kg}$$

The total mole number of the products is

$$N_m = 0.6333 + 0.2994 + 0.00832 + 3.891 + 0.2952 = 5.127 \text{ kmol}$$

The apparent molecular weight of the product gas is

$$M_m = \frac{m_m}{N_m} = \frac{152.2 \text{ kg}}{5.127 \text{ kmol}} = \mathbf{29.68 \text{ kg/kmol}}$$

The air-fuel mass ratio is then

$$\text{AF} = \frac{m_{\text{air}}}{m_{\text{fuel}}} = \frac{(1.033 \times 4.76 \times 29) \text{ kg}}{(0.6333 \times 12 + 0.2994 \times 2 + 0.05323 \times 32 + 0.00580 \times 28 + 0.00832 \times 32) \text{ kg}} \\ = \frac{142.6 \text{ kg}}{10.33 \text{ kg}} \\ = \mathbf{13.80 \text{ kg air/kg fuel}}$$

15-36 The composition of a certain coal is given. The coal is burned with 50 percent excess air. The AF ratio is to be determined.

Assumptions 1 Combustion is complete. **2** The combustion products contain CO_2 , H_2O , O_2 , N_2 , and ash only.

Properties The molar masses of C, H_2 , O_2 , and air are 12 kg/kmol, 2 kg/kmol, 32 kg/kmol, and 29 kg/kmol, respectively (Table A-1).

Analysis The composition of the coal is given on a mass basis, but we need to know the composition on a mole basis to balance the combustion equation. Considering 1 kg of coal, the numbers of mole of the each component are determined to be

$$\begin{aligned} N_{\text{C}} &= (m/M)_{\text{C}} = 0.82/12 = 0.0683 \text{ kmol} \\ N_{\text{H}_2\text{O}} &= (m/M)_{\text{H}_2\text{O}} = 0.05/18 = 0.0028 \text{ kmol} \\ N_{\text{H}_2} &= (m/M)_{\text{H}_2} = 0.02/2 = 0.01 \text{ kmol} \\ N_{\text{O}_2} &= (m/M)_{\text{O}_2} = 0.01/32 = 0.00031 \text{ kmol} \end{aligned}$$

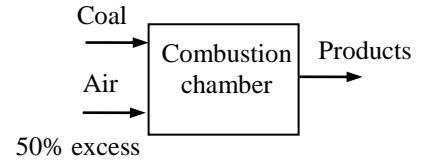

Considering 1 kg of coal, the combustion equation can be written as

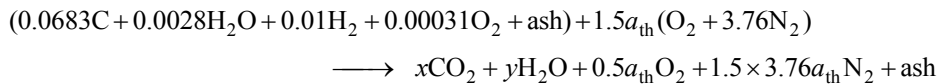

The unknown coefficients in the above equation are determined from mass balances,

$$\begin{aligned} \text{C: } 0.0683 &= x \longrightarrow x = 0.0683 \\ \text{H: } 0.0028 \times 2 + 0.01 \times 2 &= 2y \longrightarrow y = 0.0128 \\ \text{O}_2: 0.0028/2 + 0.00031 + 1.5a_{\text{th}} &= x + y/2 + 0.5a_{\text{th}} \longrightarrow a_{\text{th}} = 0.073 \end{aligned}$$

Thus,

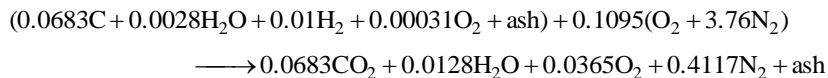

The air-fuel ratio for the this reaction is determined by taking the ratio of the mass of the air to the mass of the coal, which is taken to be 1 kg,

$$\begin{aligned} m_{\text{air}} &= (0.1095 \times 4.76 \text{ kmol})(29 \text{ kg/kmol}) = 15.1 \text{ kg} \\ m_{\text{fuel}} &= 1 \text{ kg} \end{aligned}$$

and

$$\text{AF} = \frac{m_{\text{air}}}{m_{\text{fuel}}} = \frac{15.1 \text{ kg}}{1 \text{ kg}} = \mathbf{15.1 \text{ kg air/kg fuel}}$$

Enthalpy of Formation and Enthalpy of Combustion

15-37C Enthalpy of formation is the enthalpy of a substance due to its chemical composition. The enthalpy of formation is related to elements or compounds whereas the enthalpy of combustion is related to a particular fuel.

15-38C For combustion processes the enthalpy of reaction is referred to as the enthalpy of combustion, which represents the amount of heat released during a steady-flow combustion process.

15-39C The heating value is called the higher heating value when the H₂O in the products is in the liquid form, and it is called the lower heating value when the H₂O in the products is in the vapor form. The heating value of a fuel is equal to the absolute value of the enthalpy of combustion of that fuel.

15-40C No. The enthalpy of formation of N₂ is simply assigned a value of zero at the standard reference state for convenience.

15-41C 1 kmol of H₂. This is evident from the observation that when chemical bonds of H₂ are destroyed to form H₂O a large amount of energy is released.

15-42 The enthalpy of combustion of methane at a 25°C and 1 atm is to be determined using the data from Table A-26 and to be compared to the value listed in Table A-27.

Assumptions The water in the products is in the liquid phase.

Analysis The stoichiometric equation for this reaction is

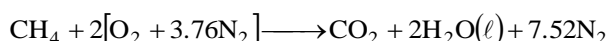

Both the reactants and the products are at the standard reference state of 25°C and 1 atm. Also, N₂ and O₂ are stable elements, and thus their enthalpy of formation is zero. Then the enthalpy of combustion of CH₄ becomes

$$h_C = H_P - H_R = \sum N_P \bar{h}_{f,P}^\circ - \sum N_R \bar{h}_{f,R}^\circ = (N \bar{h}_f^\circ)_{\text{CO}_2} + (N \bar{h}_f^\circ)_{\text{H}_2\text{O}} - (N \bar{h}_f^\circ)_{\text{CH}_4}$$

Using \bar{h}_f° values from Table A-26,

$$\begin{aligned} h_C &= (1 \text{ kmol})(-393,520 \text{ kJ/kmol}) + (2 \text{ kmol})(-285,830 \text{ kJ/kmol}) \\ &\quad - (1 \text{ kmol})(-74,850 \text{ kJ/kmol}) \\ &= \mathbf{-890,330 \text{ kJ}} \text{ (per kmol CH}_4\text{)} \end{aligned}$$

The listed value in Table A-27 is -890,868 kJ/kmol, which is almost identical to the calculated value. Since the water in the products is assumed to be in the liquid phase, this h_C value corresponds to the higher heating value of CH₄.

15-43  Problem 15-42 is reconsidered. The effect of temperature on the enthalpy of combustion is to be studied.

Analysis The problem is solved using EES, and the solution is given below.

```

Fuel$ = 'Methane (CH4)'
T_comb =25 [C]
T_fuel = T_comb +273 "[K]"
T_air1 = T_comb +273 "[K]"
T_prod =T_comb +273 "[K]"
h_bar_comb_TableA27 = -890360 [kJ/kmol]
"For theoretical dry air, the complete combustion equation is"
"CH4 + A_th(O2+3.76 N2)=1 CO2+2 H2O + A_th (3.76) N2 "

A_th*2=1*2+2*1 "theoretical O balance"

"Apply First Law SSSF"
h_fuel_EES=enthalpy(CH4,T=298) "[kJ/kmol]"
h_fuel_TableA26=-74850 "[kJ/kmol]"
h_bar_fg_H2O=enthalpy(Steam_iapws,T=298,x=1)-enthalpy(Steam_iapws,T=298,x=0) "[kJ/kmol]"
HR=h_fuel_EES+ A_th*enthalpy(O2,T=T_air1)+A_th*3.76 *enthalpy(N2,T=T_air1) "[kJ/kmol]"
HP=1*enthalpy(CO2,T=T_prod)+2*(enthalpy(H2O,T=T_prod)-h_bar_fg_H2O)+A_th*3.76*
enthalpy(N2,T=T_prod) "[kJ/kmol]"
h_bar_Comb_EES=(HP-HR) "[kJ/kmol]"
PercentError=ABS(h_bar_Comb_EES-h_bar_comb_TableA27)/ABS(h_bar_comb_TableA27)*Convert(, %) "[%]"

```

h_{CombEES} [kJ/kmol]	T_{Comb} [C]
-890335	25
-887336	88.89
-884186	152.8
-880908	216.7
-877508	280.6
-873985	344.4
-870339	408.3
-866568	472.2
-862675	536.1
-858661	600

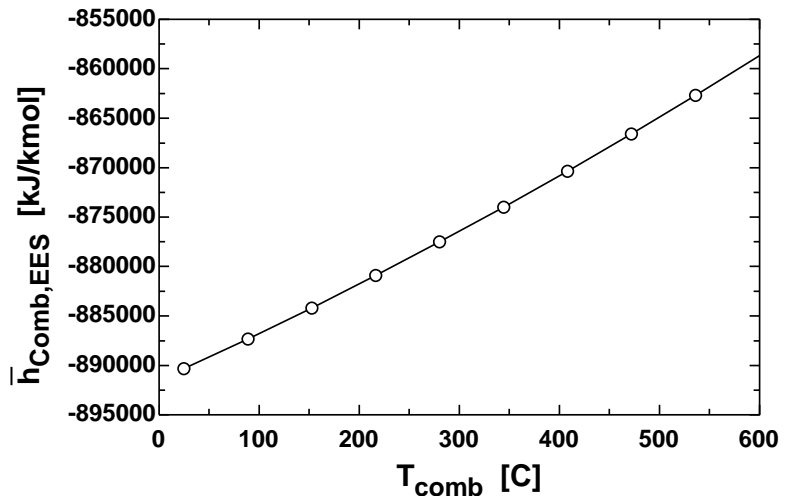

15-44 The enthalpy of combustion of gaseous ethane at a 25°C and 1 atm is to be determined using the data from Table A-26 and to be compared to the value listed in Table A-27.

Assumptions The water in the products is in the liquid phase.

Analysis The stoichiometric equation for this reaction is

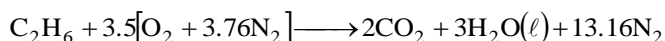

Both the reactants and the products are at the standard reference state of 25°C and 1 atm. Also, N₂ and O₂ are stable elements, and thus their enthalpy of formation is zero. Then the enthalpy of combustion of C₂H₆ becomes

$$h_C = H_P - H_R = \sum N_P \bar{h}_{f,P}^\circ - \sum N_R \bar{h}_{f,R}^\circ = (N\bar{h}_f^\circ)_{\text{CO}_2} + (N\bar{h}_f^\circ)_{\text{H}_2\text{O}} - (N\bar{h}_f^\circ)_{\text{C}_2\text{H}_6}$$

Using \bar{h}_f° values from Table A-26,

$$\begin{aligned} h_C &= (2 \text{ kmol})(-393,520 \text{ kJ/kmol}) + (3 \text{ kmol})(-285,830 \text{ kJ/kmol}) \\ &\quad - (1 \text{ kmol})(-84,680 \text{ kJ/kmol}) \\ &= \mathbf{-1,559,850 \text{ kJ}} \text{ (per kmol C}_2\text{H}_6) \end{aligned}$$

The listed value in Table A-27 is -1,560,633 kJ/kmol, which is almost identical to the calculated value. Since the water in the products is assumed to be in the liquid phase, this h_c value corresponds to the higher heating value of C₂H₆.

15-45 The enthalpy of combustion of liquid octane at a 25°C and 1 atm is to be determined using the data from Table A-26 and to be compared to the value listed in Table A-27.

Assumptions The water in the products is in the liquid phase.

Analysis The stoichiometric equation for this reaction is

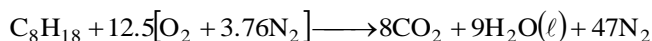

Both the reactants and the products are at the standard reference state of 25°C and 1 atm. Also, N₂ and O₂ are stable elements, and thus their enthalpy of formation is zero. Then the enthalpy of combustion of C₈H₁₈ becomes

$$h_C = H_P - H_R = \sum N_P \bar{h}_{f,P}^\circ - \sum N_R \bar{h}_{f,R}^\circ = (N\bar{h}_f^\circ)_{\text{CO}_2} + (N\bar{h}_f^\circ)_{\text{H}_2\text{O}} - (N\bar{h}_f^\circ)_{\text{C}_8\text{H}_{18}}$$

Using \bar{h}_f° values from Table A-26,

$$\begin{aligned} h_C &= (8 \text{ kmol})(-393,520 \text{ kJ/kmol}) + (9 \text{ kmol})(-285,830 \text{ kJ/kmol}) \\ &\quad - (1 \text{ kmol})(-249,950 \text{ kJ/kmol}) \\ &= \mathbf{-5,470,680 \text{ kJ}} \end{aligned}$$

The listed value in Table A-27 is -5,470,523 kJ/kmol, which is almost identical to the calculated value. Since the water in the products is assumed to be in the liquid phase, this h_c value corresponds to the higher heating value of C₈H₁₈.

15-46 Ethane is burned with stoichiometric amount of air. The heat transfer is to be determined if both the reactants and products are at 25°C.

Assumptions The water in the products is in the vapor phase.

Analysis The stoichiometric equation for this reaction is

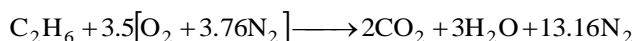

Since both the reactants and the products are at the standard reference state of 25°C and 1 atm, the heat transfer for this process is equal to enthalpy of combustion. Note that N₂ and O₂ are stable elements, and thus their enthalpy of formation is zero. Then,

$$Q = h_C = H_P - H_R = \sum N_P \bar{h}_{f,P}^\circ - \sum N_R \bar{h}_{f,R}^\circ = (N \bar{h}_f^\circ)_{\text{CO}_2} + (N \bar{h}_f^\circ)_{\text{H}_2\text{O}} - (N \bar{h}_f^\circ)_{\text{C}_2\text{H}_6}$$

Using \bar{h}_f° values from Table A-26,

$$\begin{aligned} Q = h_C &= (2 \text{ kmol})(-393,520 \text{ kJ/kmol}) + (3 \text{ kmol})(-241,820 \text{ kJ/kmol}) - (1 \text{ kmol})(-84,680 \text{ kJ/kmol}) \\ &= \mathbf{-1,427,820 \text{ kJ/kmol C}_2\text{H}_6} \end{aligned}$$

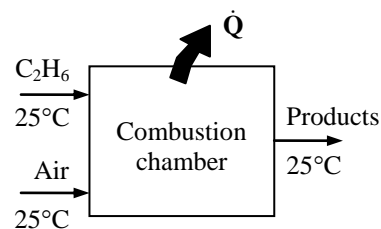

15-47 Ethane is burned with stoichiometric amount of air at 1 atm and 25°C. The minimum pressure of the products which will assure that the water in the products will be in vapor form is to be determined.

Assumptions The water in the products is in the vapor phase.

Analysis The stoichiometric equation for this reaction is

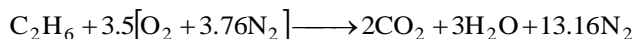

At the minimum pressure, the product mixture will be saturated with water vapor and

$$P_v = P_{\text{sat}@25^\circ\text{C}} = 3.1698 \text{ kPa}$$

The mole fraction of water in the products is

$$y_v = \frac{N_{\text{H}_2\text{O}}}{N_{\text{prod}}} = \frac{3 \text{ kmol}}{(2 + 3 + 13.16) \text{ kmol}} = 0.1652$$

The minimum pressure of the products is then

$$P_{\text{min}} = \frac{P_v}{y_v} = \frac{3.1698 \text{ kPa}}{0.1652} = \mathbf{19.2 \text{ kPa}}$$

15-48 The higher and lower heating values of liquid propane are to be determined and compared to the listed values.

Assumptions 1 Combustion is complete. **2** The combustion products contain CO_2 , H_2O , and N_2 . **3** Combustion gases are ideal gases.

Properties The molar masses of C, O_2 , H_2 , and air are 12, 32, 2, and 29 kg/kmol, respectively (Table A-1).

Analysis The combustion reaction with stoichiometric air is

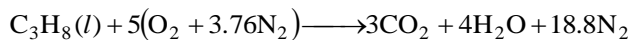

Both the reactants and the products are taken to be at the standard reference state of 25°C and 1 atm for the calculation of heating values. The heat transfer for this process is equal to enthalpy of combustion. Note that N_2 and O_2 are stable elements, and thus their enthalpy of formation is zero. Then,

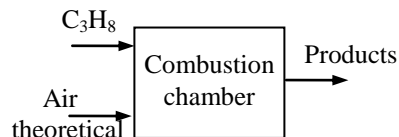

$$q = h_C = H_P - H_R = \sum N_P \bar{h}_{f,P}^\circ - \sum N_R \bar{h}_{f,R}^\circ = (N \bar{h}_f^\circ)_{\text{CO}_2} + (N \bar{h}_f^\circ)_{\text{H}_2\text{O}} - (N \bar{h}_f^\circ)_{\text{C}_3\text{H}_8}$$

The \bar{h}_f° of liquid propane is obtained by adding \bar{h}_{fg} of propane at 25°C to \bar{h}_f° of gas propane ($103,850 + 44.097 \times 335 = 118,620$ kJ/kmol). For the HHV, the water in the products is taken to be liquid. Then,

$$\begin{aligned} h_C &= (3 \text{ kmol})(-393,520 \text{ kJ/kmol}) + (4 \text{ kmol})(-285,830 \text{ kJ/kmol}) - (1 \text{ kmol})(-118,620 \text{ kJ/kmol}) \\ &= -2,205,260 \text{ kJ/kmol propane} \end{aligned}$$

The HHV of the liquid propane is

$$\text{HHV} = \frac{-h_C}{M_m} = \frac{2,205,260 \text{ kJ/kmol C}_3\text{H}_8}{44.097 \text{ kg/kmol C}_3\text{H}_8} = \mathbf{50,010 \text{ kJ/kg C}_3\text{H}_8}$$

The listed value from Table A-27 is **50,330 kJ/kg**. For the LHV, the water in the products is taken to be vapor. Then,

$$\begin{aligned} h_C &= (3 \text{ kmol})(-393,520 \text{ kJ/kmol}) + (4 \text{ kmol})(-241,820 \text{ kJ/kmol}) - (1 \text{ kmol})(-118,620 \text{ kJ/kmol}) \\ &= -2,029,220 \text{ kJ/kmol propane} \end{aligned}$$

The LHV of the propane is then

$$\text{LHV} = \frac{-h_C}{M_m} = \frac{2,029,220 \text{ kJ/kmol C}_3\text{H}_8}{44.097 \text{ kg/kmol C}_3\text{H}_8} = \mathbf{46,020 \text{ kJ/kg C}_3\text{H}_8}$$

The listed value from Table A-27 is **46,340 kJ/kg**. The calculated and listed values are practically identical.

15-49 The higher and lower heating values of coal from Illinois are to be determined.

Assumptions 1 Combustion is complete. **2** The combustion products contain CO_2 , CO , H_2O , SO_2 , and N_2 . **3** Combustion gases are ideal gases.

Properties The molar masses of C, H_2 , O_2 , S, and air are 12, 2, 32, 32, and 29 kg/kmol, respectively (Table A-1).

Analysis We consider 100 kg of coal for simplicity. Noting that the mass percentages in this case correspond to the masses of the constituents, the mole numbers of the constituent of the coal are determined to be

$$N_{\text{C}} = \frac{m_{\text{C}}}{M_{\text{C}}} = \frac{67.40 \text{ kg}}{12 \text{ kg/kmol}} = 5.617 \text{ kmol}$$

$$N_{\text{H}_2} = \frac{m_{\text{H}_2}}{M_{\text{H}_2}} = \frac{5.31 \text{ kg}}{2 \text{ kg/kmol}} = 2.655 \text{ kmol}$$

$$N_{\text{O}_2} = \frac{m_{\text{O}_2}}{M_{\text{O}_2}} = \frac{15.11 \text{ kg}}{32 \text{ kg/kmol}} = 0.4722 \text{ kmol}$$

$$N_{\text{N}_2} = \frac{m_{\text{N}_2}}{M_{\text{N}_2}} = \frac{1.44 \text{ kg}}{28 \text{ kg/kmol}} = 0.05143 \text{ kmol}$$

$$N_{\text{S}} = \frac{m_{\text{S}}}{M_{\text{S}}} = \frac{2.36 \text{ kg}}{32 \text{ kg/kmol}} = 0.07375 \text{ kmol}$$

67.40% C
5.31% H_2
15.11% O_2
1.44% N_2
2.36% S
8.38% ash (by mass)

The mole number of the mixture and the mole fractions are

$$N_m = 5.617 + 2.655 + 0.4722 + 0.05143 + 0.07375 = 8.869 \text{ kmol}$$

$$y_{\text{C}} = \frac{N_{\text{C}}}{N_m} = \frac{5.617 \text{ kmol}}{8.869 \text{ kmol}} = 0.6333$$

$$y_{\text{H}_2} = \frac{N_{\text{H}_2}}{N_m} = \frac{2.655 \text{ kmol}}{8.869 \text{ kmol}} = 0.2994$$

$$y_{\text{O}_2} = \frac{N_{\text{O}_2}}{N_m} = \frac{0.4722 \text{ kmol}}{8.869 \text{ kmol}} = 0.05323$$

$$y_{\text{N}_2} = \frac{N_{\text{N}_2}}{N_m} = \frac{0.05143 \text{ kmol}}{8.869 \text{ kmol}} = 0.00580$$

$$y_{\text{S}} = \frac{N_{\text{S}}}{N_m} = \frac{0.07375 \text{ kmol}}{8.869 \text{ kmol}} = 0.00832$$

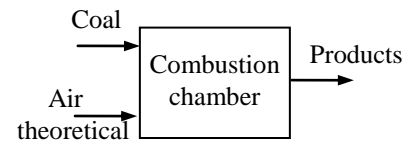

Ash consists of the non-combustible matter in coal. Therefore, the mass of ash content that enters the combustion chamber is equal to the mass content that leaves. Disregarding this non-reacting component for simplicity, the combustion equation may be written as

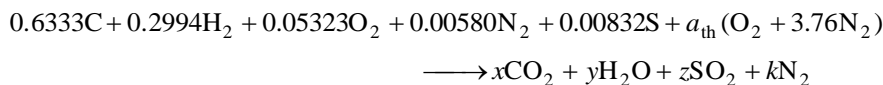

According to the species balances,

$$\text{C balance: } x = 0.6333$$

$$\text{H}_2 \text{ balance: } y = 0.2994$$

$$\text{S balance: } z = 0.00832$$

$$\text{O}_2 \text{ balance:}$$

$$0.05323 + a_{\text{th}} = x + 0.5y + z$$

$$a_{\text{th}} = 0.6333 + 0.5 \times 0.2994 + 0.00832 - 0.05323 = 0.7381$$

$$\text{N}_2 \text{ balance: } k = 0.00580 + 3.76a_{\text{th}} = 0.00580 + 3.76 \times 0.7381 = 2.781$$

Substituting,

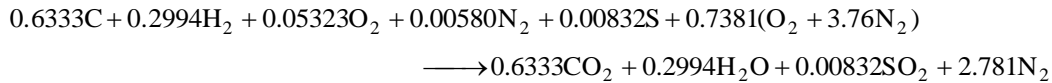

Both the reactants and the products are taken to be at the standard reference state of 25°C and 1 atm for the calculation of heating values. The heat transfer for this process is equal to enthalpy of combustion. Note that C, S, H₂, N₂ and O₂ are stable elements, and thus their enthalpy of formation is zero. Then,

$$q = h_C = H_P - H_R = \sum N_P \bar{h}_{f,P}^\circ - \sum N_R \bar{h}_{f,R}^\circ = (N\bar{h}_f^\circ)_{\text{CO}_2} + (N\bar{h}_f^\circ)_{\text{H}_2\text{O}} + (N\bar{h}_f^\circ)_{\text{SO}_2}$$

For the HHV, the water in the products is taken to be liquid. Then,

$$h_C = (0.6333 \text{ kmol})(-393,520 \text{ kJ/kmol}) + (0.2994 \text{ kmol})(-285,830 \text{ kJ/kmol}) \\ + (0.00832 \text{ kmol})(-297,100 \text{ kJ/kmol}) \\ = -337,270 \text{ kJ/kmol coal}$$

The apparent molecular weight of the coal is

$$M_m = \frac{m_m}{N_m} = \frac{(0.6333 \times 12 + 0.2994 \times 2 + 0.05323 \times 32 + 0.00580 \times 28 + 0.00832 \times 32) \text{ kg}}{(0.6333 + 0.2994 + 0.05323 + 0.00580 + 0.00832) \text{ kmol}} \\ = \frac{10.33 \text{ kg}}{1.000 \text{ kmol}} = 10.33 \text{ kg/kmol coal}$$

The HHV of the coal is then

$$\text{HHV} = \frac{-h_C}{M_m} = \frac{337,270 \text{ kJ/kmol coal}}{10.33 \text{ kg/kmol coal}} = \mathbf{32,650 \text{ kJ/kg coal}}$$

For the LHV, the water in the products is taken to be vapor. Then,

$$h_C = (0.6333 \text{ kmol})(-393,520 \text{ kJ/kmol}) + (0.2994 \text{ kmol})(-241,820 \text{ kJ/kmol}) \\ + (0.00832 \text{ kmol})(-297,100 \text{ kJ/kmol}) \\ = -324,090 \text{ kJ/kmol coal}$$

The LHV of the coal is then

$$\text{LHV} = \frac{-h_C}{M_m} = \frac{324,090 \text{ kJ/kmol coal}}{10.33 \text{ kg/kmol coal}} = \mathbf{31,370 \text{ kJ/kg coal}}$$

First Law Analysis of Reacting Systems

15-50C The heat transfer will be the same for all cases. The excess oxygen and nitrogen enters and leaves the combustion chamber at the same state, and thus has no effect on the energy balance.

15-51C For case (b), which contains the maximum amount of nonreacting gases. This is because part of the chemical energy released in the combustion chamber is absorbed and transported out by the nonreacting gases.

15-52C In this case $\Delta U + W_b = \Delta H$, and the conservation of energy relation reduces to the form of the steady-flow energy relation.

15-53 Acetylene gas is burned with 20 percent excess air during a steady-flow combustion process. The AF ratio and the heat transfer are to be determined.

Assumptions 1 Steady operating conditions exist. 2 Air and combustion gases are ideal gases. 3 Kinetic and potential energies are negligible. 4 Combustion is complete.

Properties The molar masses of C_2H_2 and air are 26 kg/kmol and 29 kg/kmol, respectively (Table A-1).

Analysis The fuel is burned completely with the excess air, and thus the products will contain only CO_2 , H_2O , N_2 , and some free O_2 . Considering 1 kmol of C_2H_2 , the combustion equation can be written as

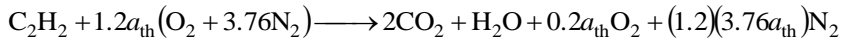

where a_{th} is the stoichiometric coefficient and is determined from the O_2 balance,

$$1.2a_{th} = 2 + 0.5 + 0.2a_{th} \longrightarrow a_{th} = 2.5$$

Thus,

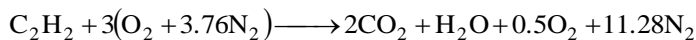

$$(a) \quad AF = \frac{m_{air}}{m_{fuel}} = \frac{(3 \times 4.76 \text{ kmol})(29 \text{ kg/kmol})}{(2 \text{ kmol})(12 \text{ kg/kmol}) + (1 \text{ kmol})(2 \text{ kg/kmol})} = \mathbf{15.9 \text{ kg air/kg fuel}}$$

(b) The heat transfer for this combustion process is determined from the energy balance $E_{in} - E_{out} = \Delta E_{system}$ applied on the combustion chamber with $W = 0$. It reduces to

$$-Q_{out} = \sum N_P (\bar{h}_f^\circ + \bar{h} - \bar{h}^\circ)_P - \sum N_R (\bar{h}_f^\circ + \bar{h} - \bar{h}^\circ)_R = \sum N_P (\bar{h}_f^\circ + \bar{h} - \bar{h}^\circ)_P - \sum N_R \bar{h}_{f,R}^\circ$$

since all of the reactants are at $25^\circ C$. Assuming the air and the combustion products to be ideal gases, we have $h = h(T)$. From the tables,

Substance	\bar{h}_f° kJ/kmol	$\bar{h}_{298 \text{ K}}$ kJ/kmol	$\bar{h}_{1500 \text{ K}}$ kJ/kmol
C_2H_2	226,730	---	---
O_2	0	8682	49,292
N_2	0	8669	47,073
$H_2O(g)$	-241,820	9904	57,999
CO_2	-393,520	9364	71,078

Thus,

$$\begin{aligned} -Q_{out} &= (2)(-393,520 + 71,078 - 9364) + (1)(-241,820 + 57,999 - 9904) + (0.5)(0 + 49,292 - 8682) \\ &\quad + (11.28)(0 + 47,073 - 8669) - (1)(226,730) - 0 - 0 \\ &= -630,565 \text{ kJ/kmol } C_2H_2 \end{aligned}$$

or

$$Q_{out} = \mathbf{630,565 \text{ kJ / kmol } } C_2H_2$$

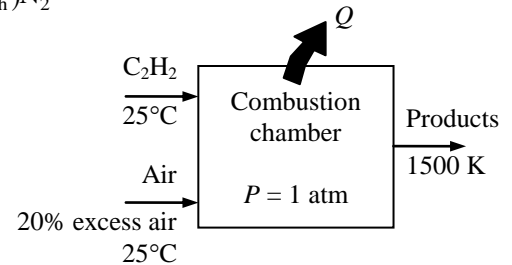

15-54E Liquid propane is burned with 150 percent excess air during a steady-flow combustion process. The mass flow rate of air and the rate of heat transfer from the combustion chamber are to be determined.

Assumptions 1 Steady operating conditions exist. 2 Air and combustion gases are ideal gases. 3 Kinetic and potential energies are negligible. 4 Combustion is complete.

Properties The molar masses of propane and air are 44 lbm/lbmol and 29 lbm/lbmol, respectively (Table A-1E).

Analysis The fuel is burned completely with the excess air, and thus the products will contain only CO_2 , H_2O , N_2 , and some free O_2 . Considering 1 kmol of C_3H_8 , the combustion equation can be written as



where a_{th} is the stoichiometric coefficient and is determined from the O_2 balance,

$$2.5a_{\text{th}} = 3 + 2 + 1.5a_{\text{th}} \longrightarrow a_{\text{th}} = 5$$

Thus,

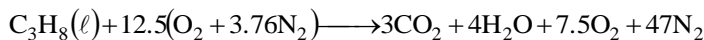

(a) The air-fuel ratio for this combustion process is

$$\text{AF} = \frac{m_{\text{air}}}{m_{\text{fuel}}} = \frac{(12.5 \times 4.76 \text{ lbmol})(29 \text{ lbm/lbmol})}{(3 \text{ lbmol})(12 \text{ lbm/lbmol}) + (4 \text{ lbmol})(2 \text{ lbm/lbmol})} = 39.2 \text{ lbm air/lbm fuel}$$

Thus, $\dot{m}_{\text{air}} = (\text{AF})(\dot{m}_{\text{fuel}}) = (39.2 \text{ lbm air/lbm fuel})(0.75 \text{ lbm fuel/min}) = \mathbf{29.4 \text{ lbm air/min}}$

(b) The heat transfer for this combustion process is determined from the energy balance $E_{\text{in}} - E_{\text{out}} = \Delta E_{\text{system}}$ applied on the combustion chamber with $W = 0$. It reduces to

$$-Q_{\text{out}} = \sum N_P (\bar{h}_f^\circ + \bar{h} - \bar{h}^\circ)_P - \sum N_R (\bar{h}_f^\circ + \bar{h} - \bar{h}^\circ)_R$$

Assuming the air and the combustion products to be ideal gases, we have $h = h(T)$. From the tables,

Substance	\bar{h}_f° Btu/lbmol	$\bar{h}_{500\text{R}}$ Btu/lbmol	$\bar{h}_{537\text{R}}$ Btu/lbmol	$\bar{h}_{1800\text{R}}$ Btu/lbmol
$\text{C}_3\text{H}_8(\ell)$	-51,160	---	---	---
O_2	0	3466.2	3725.1	13,485.8
N_2	0	3472.2	3729.5	12,956.3
CO_2	-169,300	---	4027.5	18,391.5
$\text{H}_2\text{O}(g)$	-104,040	---	4258.0	15,433.0

The \bar{h}_f° of liquid propane is obtained by adding the \bar{h}_{fg} of propane at 77°F to the \bar{h}_f° of gas propane. Substituting,

$$\begin{aligned} -Q_{\text{out}} &= (3)(-169,300 + 18,391.5 - 4027.5) + (4)(-104,040 + 15,433 - 4258) + (7.5)(0 + 13,485.8 - 3725.1) \\ &\quad + (47)(0 + 12,956.3 - 3729.5) - (1)(-51,160 + h_{537} - h_{537}) - (12.5)(0 + 3466.2 - 3725.1) \\ &\quad - (47)(0 + 3472.2 - 3729.5) \\ &= -262,773 \text{ Btu/lbmol C}_3\text{H}_8 \end{aligned}$$

or $Q_{\text{out}} = 262,773 \text{ Btu/lbmol C}_3\text{H}_8$

Then the rate of heat transfer for a mass flow rate of 0.75 kg/min for the propane becomes

$$\dot{Q}_{\text{out}} = \dot{N} Q_{\text{out}} = \left(\frac{\dot{m}}{N} \right) Q_{\text{out}} = \left(\frac{0.75 \text{ lbm/min}}{44 \text{ lbm/lbmol}} \right) (262,773 \text{ Btu/lbmol}) = \mathbf{4479 \text{ Btu/min}}$$

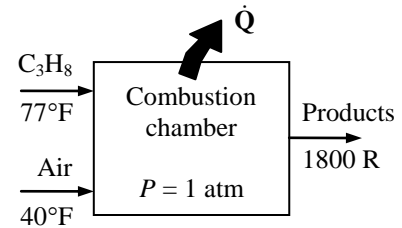

15-55 Propane is burned with an air-fuel ratio of 25. The heat transfer per kilogram of fuel burned when the temperature of the products is such that liquid water just begins to form in the products is to be determined.

Assumptions 1 Steady operating conditions exist. **2** Air and combustion gases are ideal gases. **3** Kinetic and potential energies are negligible. **4** Combustion is complete. **5** The reactants are at 25°C and 1 atm. **6** The fuel is in vapor phase.

Properties The molar masses of propane and air are 44 kg/kmol and 29 kg/kmol, respectively (Table A-1).

Analysis The mass of air per kmol of fuel is

$$m_{\text{air}} = (\text{AF})m_{\text{fuel}} \\ = (25 \text{ kg air/kg fuel})(1 \times 44 \text{ kg/kmol fuel}) = 1100 \text{ kg air/kmol fuel}$$

The mole number of air per kmol of fuel is then

$$N_{\text{air}} = \frac{m_{\text{air}}}{M_{\text{air}}} = \frac{1100 \text{ kg air/kmol fuel}}{29 \text{ kg air/kmol air}} = 37.93 \text{ kmol air/kmol fuel}$$

The combustion equation can be written as

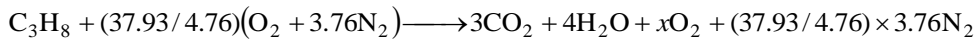

The coefficient for O₂ is obtained from O₂ balance:

$$(37.93/4.76) = 3 + 2 + x \longrightarrow x = 2.968$$

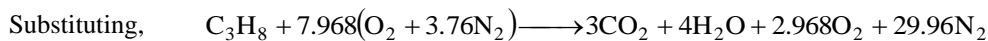

The mole fraction of water in the products is

$$y_v = \frac{N_{\text{H}_2\text{O}}}{N_{\text{prod}}} = \frac{4 \text{ kmol}}{(3 + 4 + 2.968 + 29.96) \text{ kmol}} = \frac{4 \text{ kmol}}{39.93 \text{ kmol}} = 0.1002$$

The partial pressure of water vapor at 1 atm total pressure is

$$P_v = y_v P = (0.1002)(101.325 \text{ kPa}) = 10.15 \text{ kPa}$$

When this mixture is at the dew-point temperature, the water vapor pressure is the same as the saturation pressure. Then,

$$T_{\text{dp}} = T_{\text{sat}@10.15\text{kPa}} = 46.1^\circ\text{C} = 319.1 \text{ K} \approx 320 \text{ K}$$

We obtain properties at 320 K (instead of 319.1 K) to avoid iterations in the ideal gas tables. The heat transfer for this combustion process is determined from the energy balance $E_{\text{in}} - E_{\text{out}} = \Delta E_{\text{system}}$ applied on the combustion chamber with

$W = 0$. It reduces to

$$-Q_{\text{out}} = \sum N_P (\bar{h}_f^\circ + \bar{h} - \bar{h}^\circ)_P - \sum N_R (\bar{h}_f^\circ + \bar{h} - \bar{h}^\circ)_R$$

Assuming the air and the combustion products to be ideal gases, we have $h = h(T)$. From the tables,

Substance	\bar{h}_f° , kJ/kmol	$\bar{h}_{298\text{K}}$, kJ/kmol	$\bar{h}_{320\text{K}}$, kJ/kmol
C ₃ H ₈	-103,850	---	---
O ₂	0	8682	9325
N ₂	0	8669	9306
H ₂ O (g)	-241,820	9904	10,639
CO ₂	-393,520	9364	10,186

Substituting,

$$-\bar{Q}_{\text{out}} = (3)(-393,520 + 10,186 - 9364) + (4)(-241,820 + 10,639 - 9904) + (2.968)(0 + 9325 - 8682) \\ + (29.96)(0 + 9306 - 8669) - (1)(-103,850) - 0 \\ = -2,017,590 \text{ kJ/kmol C}_3\text{H}_8$$

or $\bar{Q}_{\text{out}} = 2,017,590 \text{ kJ/kmol C}_3\text{H}_8$

Then the heat transfer per kg of fuel is

$$Q_{\text{out}} = \frac{\bar{Q}_{\text{out}}}{M_{\text{fuel}}} = \frac{2,017,590 \text{ kJ/kmol fuel}}{44 \text{ kg/kmol}} = \mathbf{45,850 \text{ kJ/kg C}_3\text{H}_8}$$

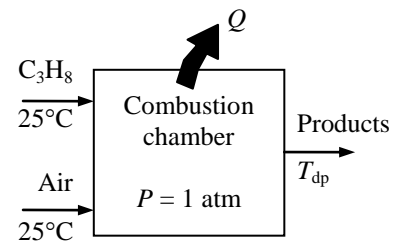

15-56 Hydrogen is burned completely during a steady-flow combustion process. The heat transfer from the combustion chamber is to be determined for two cases.

Assumptions 1 Steady operating conditions exist. 2 Air and combustion gases are ideal gases. 3 Kinetic and potential energies are negligible. 4 Combustion is complete.

Analysis The H_2 is burned completely with the stoichiometric amount of air, and thus the products will contain only H_2O and N_2 , but no free O_2 . Considering 1 kmol of H_2 , the theoretical combustion equation can be written as

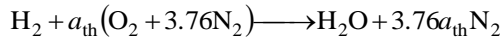

where a_{th} is determined from the O_2 balance to be $a_{\text{th}} = 0.5$.
Substituting,

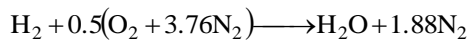

The heat transfer for this combustion process is determined from the energy balance $E_{\text{in}} - E_{\text{out}} = \Delta E_{\text{system}}$ applied on the combustion chamber with $W = 0$. It reduces to

$$-Q_{\text{out}} = \sum N_P (\bar{h}_f^\circ + \bar{h} - \bar{h}^\circ)_P - \sum N_R (\bar{h}_f^\circ + \bar{h} - \bar{h}^\circ)_R = \sum N_P \bar{h}_{f,P}^\circ - \sum N_R \bar{h}_{f,R}^\circ$$

since both the reactants and the products are at 25°C and both the air and the combustion gases can be treated as ideal gases. From the tables,

Substance	\bar{h}_f° kJ/kmol
H_2	0
O_2	0
N_2	0
$\text{H}_2\text{O} (\ell)$	-285,830

Substituting,

$$-Q_{\text{out}} = (1)(-285,830) + 0 - 0 - 0 - 0 = -285,830 \text{ kJ / kmol H}_2$$

or

$$Q_{\text{out}} = \mathbf{285,830 \text{ kJ / kmol H}_2}$$

If combustion is achieved with 50% excess air, the answer would still be the same since it would enter and leave at 25°C , and absorb no energy.

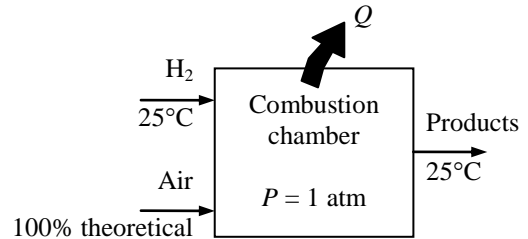

15-57 n-Octane is burned with 80 percent excess air. The heat transfer per kilogram of fuel burned for a product temperature of 217°C is to be determined.

Assumptions 1 Steady operating conditions exist. 2 Air and combustion gases are ideal gases. 3 Kinetic and potential energies are negligible. 4 Combustion is complete. 5 The fuel is in vapor phase.

Properties The molar masses of propane and air are 44 kg/kmol and 29 kg/kmol, respectively (Table A-1).

Analysis The combustion reaction for stoichiometric air is

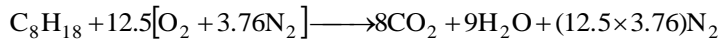

The combustion equation with 80% excess air is

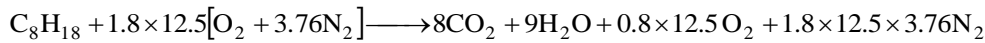

or

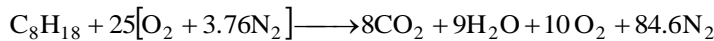

The heat transfer for this combustion process is determined from the energy balance $E_{\text{in}} - E_{\text{out}} = \Delta E_{\text{system}}$ applied on the combustion chamber with $W = 0$. It reduces to

$$-Q_{\text{out}} = \sum N_P (\bar{h}_f^\circ + \bar{h} - \bar{h}^\circ)_P - \sum N_R (\bar{h}_f^\circ + \bar{h} - \bar{h}^\circ)_R$$

Assuming the air and the combustion products to be ideal gases, we have $h = h(T)$. From the tables,

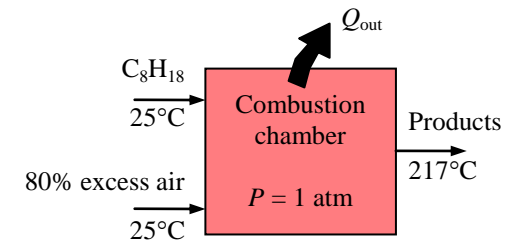

Substance	\bar{h}_f° kJ/kmol	$\bar{h}_{298\text{K}}$ kJ/kmol	$\bar{h}_{490\text{K}}$ kJ/kmol
$\text{C}_8\text{H}_{18} (g)$	-208,450	---	---
O_2	0	8682	14,460
N_2	0	8669	14,285
$\text{H}_2\text{O} (g)$	-241,820	9904	16,477
CO_2	-393,520	9364	17,232

Substituting,

$$\begin{aligned} -\bar{Q}_{\text{out}} &= (8)(-393,520 + 17,232 - 9364) + (9)(-241,820 + 16,477 - 9904) + (10)(0 + 14,460 - 8682) \\ &\quad + (84.6)(0 + 14,285 - 8669) - (1)(-208,450) - 0 - 0 \\ &= -4,239,880 \text{ kJ/kmol C}_8\text{H}_{18} \end{aligned}$$

or

$$\bar{Q}_{\text{out}} = 4,461,095 \text{ kJ/kmol C}_8\text{H}_{18}$$

Then the heat transfer per kg of fuel is

$$Q_{\text{out}} = \frac{\bar{Q}_{\text{out}}}{M_{\text{fuel}}} = \frac{4,461,095 \text{ kJ/kmol fuel}}{114 \text{ kg/kmol}} = \mathbf{39,130 \text{ kJ/kg C}_8\text{H}_{18}}$$

15-58 A certain coal is burned steadily with 40% excess air. The heat transfer for a given product temperature is to be determined.

Assumptions 1 Combustion is complete. 2 The combustion products contain CO_2 , CO , H_2O , SO_2 , and N_2 . 3 Combustion gases are ideal gases.

Properties The molar masses of C, H_2 , N_2 , O_2 , S, and air are 12, 2, 28, 32, 32, and 29 kg/kmol, respectively (Table A-1).

Analysis We consider 100 kg of coal for simplicity. Noting that the mass percentages in this case correspond to the masses of the constituents, the mole numbers of the constituent of the coal are determined to be

$$N_{\text{C}} = \frac{m_{\text{C}}}{M_{\text{C}}} = \frac{39.25 \text{ kg}}{12 \text{ kg/kmol}} = 3.271 \text{ kmol}$$

$$N_{\text{H}_2} = \frac{m_{\text{H}_2}}{M_{\text{H}_2}} = \frac{6.93 \text{ kg}}{2 \text{ kg/kmol}} = 3.465 \text{ kmol}$$

$$N_{\text{O}_2} = \frac{m_{\text{O}_2}}{M_{\text{O}_2}} = \frac{41.11 \text{ kg}}{32 \text{ kg/kmol}} = 1.285 \text{ kmol}$$

$$N_{\text{N}_2} = \frac{m_{\text{N}_2}}{M_{\text{N}_2}} = \frac{0.72 \text{ kg}}{28 \text{ kg/kmol}} = 0.0257 \text{ kmol}$$

$$N_{\text{S}} = \frac{m_{\text{S}}}{M_{\text{S}}} = \frac{0.79 \text{ kg}}{32 \text{ kg/kmol}} = 0.0247 \text{ kmol}$$

39.25% C
6.93% H_2
41.11% O_2
0.72% N_2
0.79% S
11.20% ash (by mass)

The mole number of the mixture and the mole fractions are

$$N_m = 3.271 + 3.465 + 1.285 + 0.0257 + 0.0247 = 8.071 \text{ kmol}$$

$$y_{\text{C}} = \frac{N_{\text{C}}}{N_m} = \frac{3.271 \text{ kmol}}{8.071 \text{ kmol}} = 0.4052$$

$$y_{\text{H}_2} = \frac{N_{\text{H}_2}}{N_m} = \frac{3.465 \text{ kmol}}{8.071 \text{ kmol}} = 0.4293$$

$$y_{\text{O}_2} = \frac{N_{\text{O}_2}}{N_m} = \frac{1.285 \text{ kmol}}{8.071 \text{ kmol}} = 0.1592$$

$$y_{\text{N}_2} = \frac{N_{\text{N}_2}}{N_m} = \frac{0.0257 \text{ kmol}}{8.071 \text{ kmol}} = 0.00319$$

$$y_{\text{S}} = \frac{N_{\text{S}}}{N_m} = \frac{0.0247 \text{ kmol}}{8.071 \text{ kmol}} = 0.00306$$

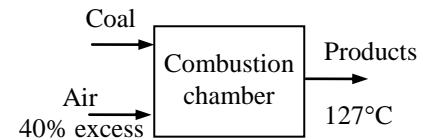

Ash consists of the non-combustible matter in coal. Therefore, the mass of ash content that enters the combustion chamber is equal to the mass content that leaves. Disregarding this non-reacting component for simplicity, the combustion equation may be written as

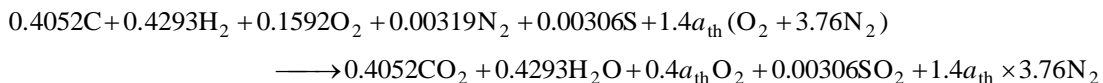

According to the O_2 mass balance,

$$0.1592 + 1.4a_{\text{th}} = 0.4052 + 0.5 \times 0.4293 + 0.4a_{\text{th}} + 0.00306 \longrightarrow a_{\text{th}} = 0.4637$$

Substituting,

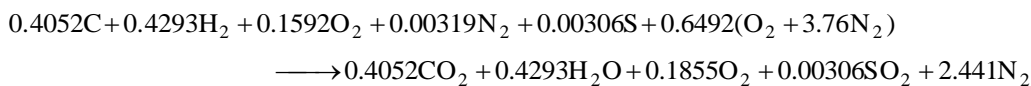

The heat transfer for this combustion process is determined from the energy balance $E_{\text{in}} - E_{\text{out}} = \Delta E_{\text{system}}$ applied on the combustion chamber with $W = 0$. It reduces to

$$-Q_{\text{out}} = \sum N_P (\bar{h}_f^\circ + \bar{h} - \bar{h}^\circ)_P - \sum N_R (\bar{h}_f^\circ + \bar{h} - \bar{h}^\circ)_R$$

Assuming the air and the combustion products to be ideal gases, we have $h = h(T)$. From the tables,

Substance	\bar{h}_f° kJ/kmol	$\bar{h}_{298\text{K}}$ kJ/kmol	$\bar{h}_{400\text{K}}$ kJ/kmol
O ₂	0	8682	11,711
N ₂	0	8669	11,640
H ₂ O (g)	-241,820	9904	13,356
CO ₂	-393,520	9364	13,372
SO ₂	-297,100	-	-

The enthalpy change of sulfur dioxide between the standard temperature and the product temperature using constant specific heat assumption is

$$\Delta \bar{h}_{\text{SO}_2} = c_p \Delta T = (41.7 \text{ kJ/kmol} \cdot \text{K})(127 - 25)\text{K} = 4253 \text{ kJ/kmol}$$

Substituting into the energy balance relation,

$$\begin{aligned} -\bar{Q}_{\text{out}} &= (0.4052)(-393,520 + 13,372 - 9364) + (0.4293)(-241,820 + 13,356 - 9904) \\ &\quad + (0.1855)(0 + 11,711 - 8682) + (2.441)(0 + 11,640 - 8669) + (0.00306)(-297,100 + 4253) - 0 \\ &= -253,244 \text{ kJ/kmol C}_8\text{H}_{18} \end{aligned}$$

or $\bar{Q}_{\text{out}} = 253,244 \text{ kJ/kmol fuel}$

Then the heat transfer per kg of fuel is

$$\begin{aligned} Q_{\text{out}} &= \frac{\bar{Q}_{\text{out}}}{M_{\text{fuel}}} = \frac{253,244 \text{ kJ/kmol fuel}}{(0.4052 \times 12 + 0.4293 \times 2 + 0.1592 \times 32 + 0.00319 \times 28 + 0.00306 \times 32) \text{ kg/kmol}} \\ &= \frac{253,244 \text{ kJ/kmol fuel}}{11.00 \text{ kg/kmol}} \\ &= \mathbf{23,020 \text{ kJ/kg coal}} \end{aligned}$$



15-59 Octane gas is burned with 30 percent excess air during a steady-flow combustion process. The heat transfer per unit mass of octane is to be determined.

Assumptions 1 Steady operating conditions exist. 2 Air and combustion gases are ideal gases. 3 Kinetic and potential energies are negligible. 4 Combustion is complete.

Properties The molar mass of C_8H_{18} is 114 kg/kmol (Table A-1).

Analysis The fuel is burned completely with the excess air, and thus the products will contain only CO_2 , H_2O , N_2 , and some free O_2 . The moisture in the air does not react with anything; it simply shows up as additional H_2O in the products.

Therefore, for simplicity, we will balance the combustion equation using dry air, and then add the moisture to both sides of the equation. Considering 1 kmol of C_8H_{18} , the combustion equation can be written as



where a_{th} is the stoichiometric coefficient for air. It is determined from

$$O_2 \text{ balance : } 1.8a_{th} = 8 + 4.5 + 0.8a_{th} \longrightarrow a_{th} = 12.5$$

Thus,

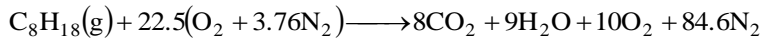

Therefore, $22.5 \times 4.76 = 107.1$ kmol of dry air will be used per kmol of the fuel. The partial pressure of the water vapor present in the incoming air is

$$P_{v,in} = \phi_{air} P_{sat@25^\circ C} = (0.40)(3.1698 \text{ kPa}) = 1.268 \text{ kPa}$$

Assuming ideal gas behavior, the number of moles of the moisture that accompanies 107.1 kmol of incoming dry air is determined to be

$$N_{v,in} = \left(\frac{P_{v,in}}{P_{total}} \right) N_{total} = \left(\frac{1.268 \text{ kPa}}{101.325 \text{ kPa}} \right) (107.1 + N_{v,in}) \longrightarrow N_{v,in} = 1.36 \text{ kmol}$$

The balanced combustion equation is obtained by adding 1.36 kmol of H_2O to both sides of the equation,

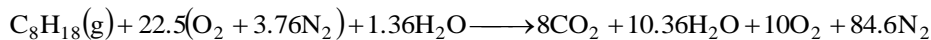

The heat transfer for this combustion process is determined from the energy balance $E_{in} - E_{out} = \Delta E_{system}$ applied on the combustion chamber with $W = 0$. It reduces to

$$-Q_{out} = \sum N_P (\bar{h}_f^\circ + \bar{h} - \bar{h}^\circ)_P - \sum N_R (\bar{h}_f^\circ + \bar{h} - \bar{h}^\circ)_R = \sum N_P (\bar{h}_f^\circ + \bar{h} - \bar{h}^\circ)_P - \sum N_R \bar{h}_{f,R}^\circ$$

since all of the reactants are at $25^\circ C$. Assuming the air and the combustion products to be ideal gases, we have $h = h(T)$. From the tables,

Substance	\bar{h}_f° , kJ/kmol	\bar{h}_{298K} , kJ/kmol	\bar{h}_{1000K} , kJ/kmol
$C_8H_{18}(g)$	-208,450	---	---
O_2	0	8682	31,389
N_2	0	8669	30,129
$H_2O(g)$	-241,820	9904	35,882
CO_2	-393,520	9364	42,769

Substituting,

$$\begin{aligned} -Q_{out} &= (8)(-393,520 + 42,769 - 9364) + (10.36)(-241,820 + 35,882 - 9904) \\ &\quad + (10)(0 + 31,389 - 8682) + (84.6)(0 + 30,129 - 8669) \\ &\quad - (1)(-208,450) - (1.36)(-241,820) - 0 - 0 \\ &= -2,537,130 \text{ kJ/kmol } C_8H_{18} \end{aligned}$$

Thus 2,537,130 kJ of heat is transferred from the combustion chamber for each kmol (114 kg) of C_8H_{18} . Then the heat transfer per kg of C_8H_{18} becomes

$$q = \frac{Q_{out}}{M} = \frac{2,537,130 \text{ kJ}}{114 \text{ kg}} = \mathbf{22,260 \text{ kJ/kg } C_8H_{18}}$$

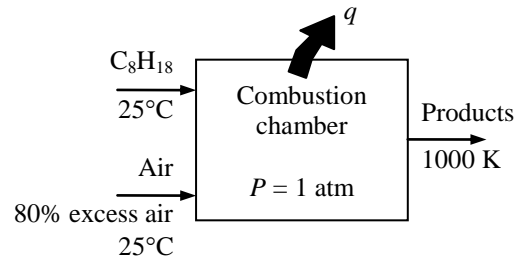



15-60 Problem 15-59 is reconsidered. The effect of the amount of excess air on the heat transfer for the combustion process is to be investigated.

Analysis The problem is solved using EES, and the solution is given below.

```

Fuel$ = 'Octane (C8H18)'
T_fuel = (25+273) "[K]"
{PercentEX = 80 "[%]"}
Ex = PercentEX/100 "[%Excess air/100]"
P_air1 = 101.3 [kPa]
T_air1 = 25+273 "[K]"
RH_1 = 40/100 "[%]"
T_prod = 1000 [K]
M_air = 28.97 [kg/kmol]
M_water = 18 [kg/kmol]
M_C8H18=(8*12+18*1) "[kg/kmol]"
"For theoretical dry air, the complete combustion equation is"
"C8H18 + A_th(O2+3.76 N2)=8 CO2+9 H2O + A_th (3.76) N2 "
A_th*2=8*2+9*1 "theoretical O balance"
"now to find the amount of water vapor associated with the dry air"
w_1=HUMRAT(AirH2O,T=T_air1,P=P_air1,R=RH_1) "Humidity ratio, kgv/kga"
N_w=w_1*(A_th*4.76*M_air)/M_water "Moles of water in the atmospheric air, kmol/kmol_fuel"
"The balanced combustion equation with Ex% excess moist air is"
"C8H18 + (1+EX)[A_th(O2+3.76 N2)+N_w H2O]=8 CO2+(9+(1+Ex)*N_w) H2O + (1+Ex) A_th (3.76) N2+ Ex(
A_th) O2 "
"Apply First Law SSSF"
H_fuel = -208450 [kJ/kmol] "from Table A-26"
HR=H_fuel+ (1+Ex)*A_th*enthalpy(O2,T=T_air1)+(1+Ex)*A_th*3.76
*enthalpy(N2,T=T_air1)+(1+Ex)*N_w*enthalpy(H2O,T=T_air1)
HP=8*enthalpy(CO2,T=T_prod)+(9+(1+Ex)*N_w)*enthalpy(H2O,T=T_prod)+(1+Ex)*A_th*3.76*
enthalpy(N2,T=T_prod)+Ex*A_th*enthalpy(O2,T=T_prod)
Q_net=(HP-HR)"kJ/kmol"/(M_C8H18 "kg/kmol") "[kJ/kg_C8H18]"
Q_out = -Q_net "[kJ/kg_C8H18]"

```

"This solution used the humidity ratio from psychrometric data to determine the moles of water vapor in atmospheric air. One should calculate the moles of water contained in the atmospheric air by the method shown in Chapter 14 which uses the relative humidity to find the partial pressure of the water vapor and, thus, the moles of water vapor. Explore what happens to the results as you vary the percent excess air, relative humidity, and product temperature."

PercentEX [%]	Q _{out} [kJ/kgC8H18]
0	31444
20	29139
40	26834
60	24529
80	22224
100	19919
120	17614
140	15309
160	13003
180	10698
200	8393

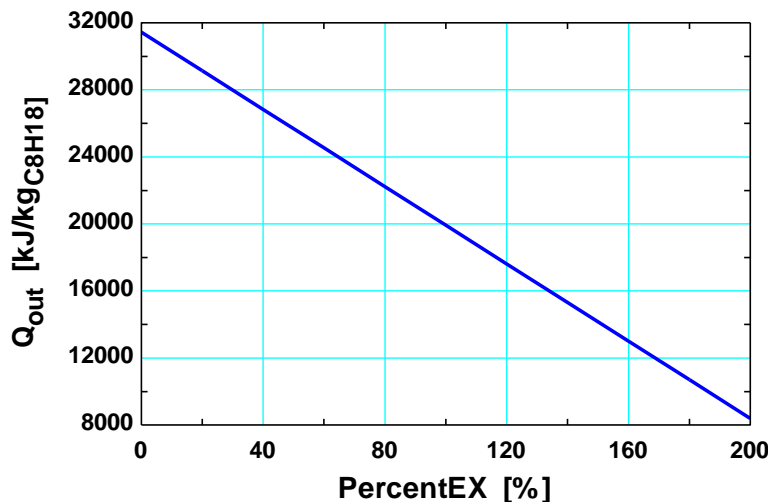

15-61 Diesel fuel is burned with 20 percent excess air during a steady-flow combustion process. The required mass flow rate of the diesel fuel to supply heat at a specified rate is to be determined.

Assumptions 1 Steady operating conditions exist. 2 Air and combustion gases are ideal gases. 3 Kinetic and potential energies are negligible. 4 Combustion is complete.

Analysis The fuel is burned completely with the excess air, and thus the products will contain only CO_2 , H_2O , N_2 , and some free O_2 . Considering 1 kmol of $\text{C}_{12}\text{H}_{26}$, the combustion equation can be written as



where a_{th} is the stoichiometric coefficient and is determined from the O_2 balance,

$$1.2a_{\text{th}} = 12 + 6.5 + 0.2a_{\text{th}} \longrightarrow a_{\text{th}} = 18.5$$

Substituting,

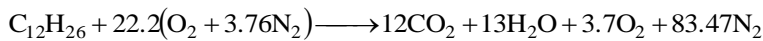

The heat transfer for this combustion process is determined from the energy balance $E_{\text{in}} - E_{\text{out}} = \Delta E_{\text{system}}$ applied on the combustion chamber with $W = 0$. It reduces to

$$-Q_{\text{out}} = \sum N_P (\bar{h}_f^\circ + \bar{h} - \bar{h}^\circ)_P - \sum N_R (\bar{h}_f^\circ + \bar{h} - \bar{h}^\circ)_R = \sum N_P (\bar{h}_f^\circ + \bar{h} - \bar{h}^\circ)_P - \sum N_R \bar{h}_{f,R}^\circ$$

since all of the reactants are at 25°C . Assuming the air and the combustion products to be ideal gases, we have $h = h(T)$. From the tables,

Substance	\bar{h}_f° kJ/kmol	$\bar{h}_{298\text{ K}}$ kJ/kmol	$\bar{h}_{500\text{ K}}$ kJ/kmol
$\text{C}_{12}\text{H}_{26}$	-291,010	---	---
O_2	0	8682	14,770
N_2	0	8669	14,581
$\text{H}_2\text{O} (g)$	-241,820	9904	16,828
CO_2	-393,520	9364	17,678

Thus,

$$\begin{aligned} -Q_{\text{out}} &= (12)(-393,520 + 17,678 - 9364) + (13)(-241,820 + 16,828 - 9904) \\ &\quad + (3.7)(0 + 14,770 - 8682) + (83.47)(0 + 14,581 - 8669) - (1)(-291,010) - 0 - 0 \\ &= -6,869,110 \text{ kJ/kmol } \text{C}_{12}\text{H}_{26} \end{aligned}$$

or $\dot{Q}_{\text{out}} = 6,869,110 \text{ kJ/kmol } \text{C}_{12}\text{H}_{26}$

Then the required mass flow rate of fuel for a heat transfer rate of 2000 kJ/s becomes

$$\dot{m} = \dot{N}M = \left(\frac{\dot{Q}_{\text{out}}}{Q_{\text{out}}} \right) M = \left(\frac{2000 \text{ kJ/s}}{6,869,110 \text{ kJ/kmol}} \right) (170 \text{ kg/kmol}) = 0.0495 \text{ kg/s} = \mathbf{49.5 \text{ g/s}}$$

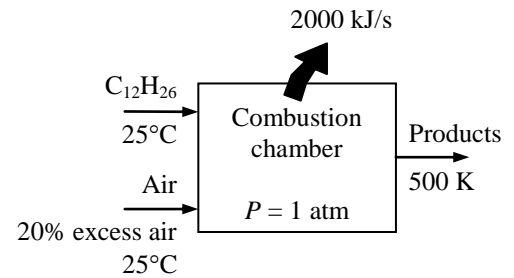

15-62 Liquid ethyl alcohol, C_2H_5OH (liq), is burned in a steady-flow combustion chamber with 40 percent excess air. The required volume flow rate of the liquid ethyl alcohol is to be determined.

Assumptions 1 Combustion is complete. **2** The combustion products contain CO_2 , H_2O , O_2 , and N_2 only.

Properties The molar masses of C, H_2 , O_2 and air are 12 kg/kmol, 2 kg/kmol, 32 kg/kmol, and 29 kg/kmol, respectively (Table A-1).

Analysis The reaction equation for 40% excess air is

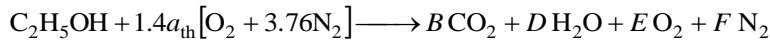

where a_{th} is the stoichiometric coefficient for air. We have automatically accounted for the 40% excess air by using the factor $1.4a_{th}$ instead of a_{th} for air. The coefficient a_{th} and other coefficients are to be determined from the mass balances

$$\text{Carbon balance:} \quad B = 2$$

$$\text{Hydrogen balance:} \quad 2D = 6 \longrightarrow D = 3$$

$$\text{Oxygen balance:} \quad 1 + 2 \times 1.4a_{th} = 2B + D + 2E$$

$$0.4a_{th} = E$$

$$\text{Nitrogen balance:} \quad 1.4a_{th} \times 3.76 = F$$

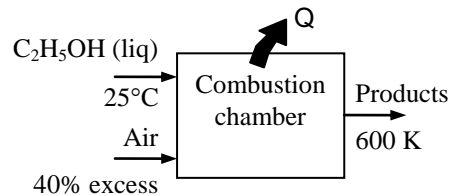

Solving the above equations, we find the coefficients ($E = 1.2$, $F = 15.79$, and $a_{th} = 3$) and write the balanced reaction equation as

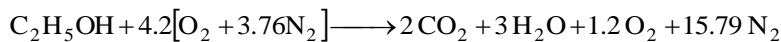

The steady-flow energy balance is expressed as

$$\dot{N}_{fuel} H_R = \dot{Q}_{out} + \dot{N}_{fuel} H_P$$

where

$$\begin{aligned} H_R &= (\bar{h}_f^\circ - \bar{h}_{fg})_{fuel} + 4.2\bar{h}_{O_2@298.15K} + (4.2 \times 3.76)\bar{h}_{N_2@298.15K} \\ &= -235,310 \text{ kJ/kmol} - 42,340 \text{ kJ/kmol} + 4.2(-4.425 \text{ kJ/kmol}) + (4.2 \times 3.76)(-4.376 \text{ kJ/kmol}) \\ &= -277,650 \text{ kJ/kmol} \end{aligned}$$

$$\begin{aligned} H_P &= 2\bar{h}_{CO_2@600K} + 3\bar{h}_{H_2O@600K} + 1.2\bar{h}_{O_2@600K} + 15.79\bar{h}_{N_2@600K} \\ &= 2(-380,623 \text{ kJ/kmol}) + 3(-231,333 \text{ kJ/kmol}) + 1.2(9251 \text{ kJ/kmol}) + 15.79(8889 \text{ kJ/kmol}) \\ &= -1.304 \times 10^6 \text{ kJ/kmol} \end{aligned}$$

The enthalpies are obtained from EES except for the enthalpy of formation of the fuel, which is obtained in Table A-27 of the book. Substituting into the energy balance equation,

$$\begin{aligned} \dot{N}_{fuel} H_R &= \dot{Q}_{out} + \dot{N}_{fuel} H_P \\ \dot{N}_{fuel} (-277,650 \text{ kJ/kmol}) &= 2000 \text{ kJ/s} + \dot{N}_{fuel} (-1.304 \times 10^6 \text{ kJ/kmol}) \longrightarrow \dot{N}_{fuel} = 0.001949 \text{ kmol/s} \end{aligned}$$

The fuel mass flow rate is

$$\dot{m}_{fuel} = \dot{N}_{fuel} M_{fuel} = (0.001949 \text{ kmol/s})(2 \times 12 + 6 \times 1 + 16) \text{ kg/kmol} = 0.08966 \text{ kg/s}$$

Then, the volume flow rate of the fuel is determined to be

$$\dot{V}_{fuel} = \frac{\dot{m}_{fuel}}{\rho_{fuel}} = \frac{0.08966 \text{ kg/s}}{790 \text{ kg/m}^3} \left(\frac{6000 \text{ L/min}}{1 \text{ m}^3/\text{s}} \right) = \mathbf{6.81 \text{ L/min}}$$

15-63 A mixture of propane and methane is burned with theoretical air. The balanced chemical reaction is to be written, and the amount of water vapor condensed and the the required air flow rate for a given heat transfer rate are to be determined.

Assumptions 1 Combustion is complete. 2 The combustion products contain CO_2 , CO , H_2O , O_2 , and N_2 only.

Properties The molar masses of C, H_2 , O_2 , N_2 and air are 12 kg/kmol, 2 kg/kmol, 32 kg/kmol, 28 kg/kmol, and 29 kg/kmol, respectively (Table A-1).

Analysis (a) The balanced reaction equation for stoichiometric air is

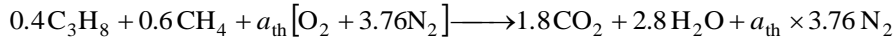

The stoichiometric coefficient a_{th} is determined from an O_2 balance:

$$a_{\text{th}} = 1.8 + 1.4 = 3.2$$

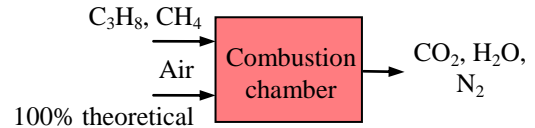

Substituting,

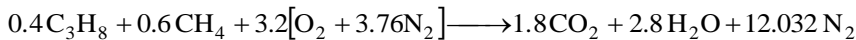

(b) The partial pressure of water vapor is

$$P_v = \frac{N_{\text{H}_2\text{O}}}{N_{\text{total}}} P_{\text{total}} = \frac{2.8}{1.8 + 2.8 + 12.032} (100 \text{ kPa}) = \frac{2.8 \text{ kmol}}{16.632 \text{ kmol}} (100 \text{ kPa}) = 16.84 \text{ kPa}$$

The dew point temperature of the product gases is the saturation temperature of water at this pressure:

$$T_{dp} = T_{\text{sat}@16.84\text{kPa}} = 56.2^\circ\text{C} \quad (\text{Table A-5})$$

Since the temperature of the product gases are at 423 K (150°C), there will be no condensation of water vapor.

(c) The heat transfer for this combustion process is determined from the energy balance $E_{\text{in}} - E_{\text{out}} = \Delta E_{\text{system}}$ applied on the combustion chamber with $W = 0$. It reduces to

$$-Q_{\text{out}} = \sum N_P (\bar{h}_f^\circ + \bar{h} - \bar{h}^\circ)_P - \sum N_R (\bar{h}_f^\circ + \bar{h} - \bar{h}^\circ)_R$$

The products are at 125°C , and the enthalpy of products can be expressed as

$$(\bar{h} - \bar{h}^\circ) = \bar{c}_p \Delta T$$

where $\Delta T = 150 - 25 = 125^\circ\text{C} = 125 \text{ K}$. Then, using the values given in the table,

$$\begin{aligned} -Q_{\text{out}} &= (1.8)(-393,520 + 41.16 \times 125) + (2.8)(-241,820 + 34.28 \times 125) + (12.032)(0 + 29.27 \times 125) \\ &\quad - (0.4)(-103,850) - (0.6)(-74,850) \\ &= -1,233,700 \text{ kJ/kmol fuel} \end{aligned}$$

or $Q_{\text{out}} = 1,233,700 \text{ kJ/kmol fuel}$

For a heat transfer rate of 140,000 kJ/h, the molar flow rate of fuel is

$$\dot{N}_{\text{fuel}} = \frac{\dot{Q}_{\text{out}}}{Q_{\text{out}}} = \frac{140,000 \text{ kJ/h}}{1,246,760 \text{ kJ/kmol fuel}} = 0.1135 \text{ kmol fuel/h}$$

The molar mass of the fuel mixture is

$$M_{\text{fuel}} = 0.4 \times 44 + 0.6 \times 16 = 27.2 \text{ kg/kmol}$$

The mass flow rate of fuel is

$$\dot{m}_{\text{fuel}} = \dot{N}_{\text{fuel}} M_{\text{fuel}} = (0.1135 \text{ kmol/h})(27.2 \text{ kg/kmol}) = 3.087 \text{ kg/h}$$

The air-fuel ratio is

$$\text{AF} = \frac{m_{\text{air}}}{m_{\text{fuel}}} = \frac{(3.2 \times 4.76 \times 29) \text{ kg}}{(0.4 \times 44 + 0.6 \times 16) \text{ kg}} = 16.24 \text{ kg air/kg fuel}$$

The mass flow rate of air is then

$$\dot{m}_{\text{air}} = \dot{m}_{\text{fuel}} \text{AF} = (3.087 \text{ kg/h})(16.24) = \mathbf{50.1 \text{ kg/h}}$$

15-64 A mixture of ethanol and octane is burned with 10% excess air. The combustion is incomplete. The balanced chemical reaction is to be written, and the dew-point temperature of the products, the heat transfer for the process, and the relative humidity of atmospheric air for specified conditions are to be determined.

Assumptions 1 Combustion is incomplete. **2** The combustion products contain CO_2 , CO , H_2O , O_2 , and N_2 only.

Properties The molar masses of C, H_2 , O_2 , N_2 and air are 12 kg/kmol, 2 kg/kmol, 32 kg/kmol, 28 kg/kmol, and 29 kg/kmol, respectively (Table A-1).

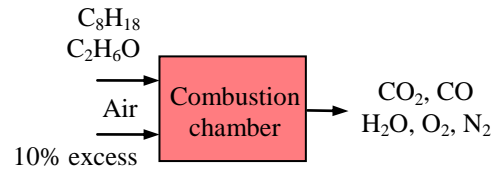

Analysis (a) The balanced reaction equation for stoichiometric air is

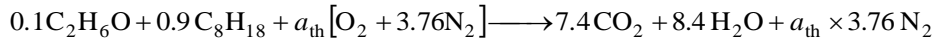

The stoichiometric coefficient a_{th} is determined from an O_2 balance:

$$0.1/2 + a_{\text{th}} = 7.4 + 8.4/2 \longrightarrow a_{\text{th}} = 11.55$$

Substituting,

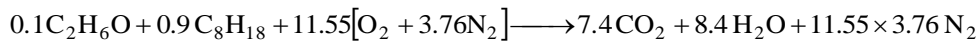

The reaction with 10% excess air and incomplete combustion can be written as

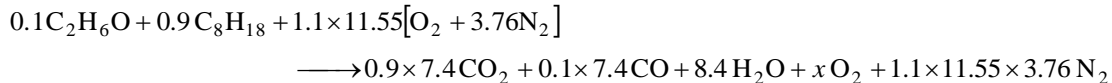

The coefficient for O_2 is determined from a mass balance,

$$\text{O}_2 \text{ balance: } 0.5 \times 0.1 + 1.1 \times 11.55 = 0.9 \times 7.4 + 0.5 \times (0.1 \times 7.4) + 0.5 \times 8.4 + x \longrightarrow x = 1.525$$

Substituting,

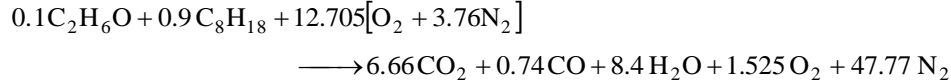

(b) The partial pressure of water vapor is

$$P_v = \frac{N_{\text{H}_2\text{O}}}{N_{\text{total}}} P_{\text{total}} = \frac{8.4}{6.66 + 0.74 + 8.4 + 1.525 + 47.77} (100 \text{ kPa}) = \frac{8.4 \text{ kmol}}{65.10 \text{ kmol}} (100 \text{ kPa}) = 12.9 \text{ kPa}$$

The dew point temperature of the product gases is the saturation temperature of water at this pressure:

$$T_{dp} = T_{\text{sat}@12.9\text{kPa}} = \mathbf{50.5^\circ\text{C}} \quad (\text{Table A-5})$$

(c) The heat transfer for this combustion process is determined from the energy balance $E_{\text{in}} - E_{\text{out}} = \Delta E_{\text{system}}$ applied on the combustion chamber with $W = 0$. It reduces to

$$-Q_{\text{out}} = \sum N_P (\bar{h}_f^\circ + \bar{h} - \bar{h}^\circ)_P - \sum N_R (\bar{h}_f^\circ + \bar{h} - \bar{h}^\circ)_R$$

Both the reactants and products are at 25°C . Assuming the air and the combustion products to be ideal gases, we have $h = h(T)$. Then, using the values given in the table,

$$\begin{aligned} -Q_{\text{out}} &= (6.66)(-393,520) + (0.74)(-110,530) + (8.4)(-241,820) - (0.1)(-235,310) - (0.9)(-208,450) \\ &= -4,522,790 \text{ kJ/kmol fuel} \end{aligned}$$

or $Q_{\text{out}} = 4,522,790 \text{ kJ/kmol fuel}$

The molar mass of the fuel is

$$M = 0.1 \times 46 + 0.9 \times 114 = 107.2 \text{ kg/kmol}$$

Then the heat transfer for a 2.5 kg of fuel becomes

$$Q_{\text{out}} = NQ_{\text{out}} = \left(\frac{m}{M} \right) Q_{\text{out}} = \frac{2.5 \text{ kg}}{107.2 \text{ kg/kmol}} (4,522,790 \text{ kJ/mol}) = \mathbf{105,480 \text{ kJ}}$$

(d) For 9.57 kmol of water vapor in the products, the air must carry $9.57 - 8.4 = 1.17$ kmol of water vapor in the atmospheric air. The partial pressure of this water vapor in the atmospheric air is

$$P_v = \frac{N_{\text{H}_2\text{O}}}{N_{\text{total}}} P_{\text{total}} = \frac{1.17}{12.705 \times 4.76 + 1.17} (100 \text{ kPa}) = \frac{1.17 \text{ kmol}}{61.65 \text{ kmol}} (100 \text{ kPa}) = 1.8979 \text{ kPa}$$

The saturation pressure of water at 25°C is 3.17 kPa (Table A-4). The relative humidity of water vapor in the atmospheric air is then

$$\phi = \frac{P_v}{P_{\text{total}}} = \frac{1.8979 \text{ kPa}}{3.17 \text{ kPa}} = 0.599 = \mathbf{59.9\%}$$

15-65  A mixture of methane and oxygen contained in a tank is burned at constant volume. The final pressure in the tank and the heat transfer during this process are to be determined.

Assumptions **1** Air and combustion gases are ideal gases. **2** Combustion is complete.

Properties The molar masses of CH_4 and O_2 are 16 kg/kmol and 32 kg/kmol, respectively (Table A-1).

Analysis (a) The combustion is assumed to be complete, and thus all the carbon in the methane burns to CO_2 and all of the hydrogen to H_2O . The number of moles of CH_4 and O_2 in the tank are

$$N_{\text{CH}_4} = \frac{m_{\text{CH}_4}}{M_{\text{CH}_4}} = \frac{0.12 \text{ kg}}{16 \text{ kg/kmol}} = 7.5 \times 10^{-3} \text{ kmol} = 7.5 \text{ mol}$$

$$N_{\text{O}_2} = \frac{m_{\text{O}_2}}{M_{\text{O}_2}} = \frac{0.6 \text{ kg}}{32 \text{ kg/kmol}} = 18.75 \times 10^{-3} \text{ kmol} = 18.75 \text{ mol}$$

Then the combustion equation can be written as

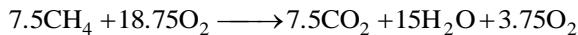

At 1200 K, water exists in the gas phase. Assuming both the reactants and the products to be ideal gases, the final pressure in the tank is determined to be

$$\left. \begin{array}{l} P_R \mathcal{V} = N_R R_u T_R \\ P_P \mathcal{V} = N_P R_u T_P \end{array} \right\} P_P = P_R \left(\frac{N_P}{N_R} \right) \left(\frac{T_P}{T_R} \right)$$

Substituting,

$$P_P = (200 \text{ kPa}) \left(\frac{26.25 \text{ mol}}{26.25 \text{ mol}} \right) \left(\frac{1200 \text{ K}}{298 \text{ K}} \right) = \mathbf{805 \text{ kPa}}$$

which is relatively low. Therefore, the ideal gas assumption utilized earlier is appropriate.

(b) The heat transfer for this constant volume combustion process is determined from the energy balance

$E_{\text{in}} - E_{\text{out}} = \Delta E_{\text{system}}$ applied on the combustion chamber with $W = 0$. It reduces to

$$-Q_{\text{out}} = \sum N_P (\bar{h}_f^\circ + \bar{h} - \bar{h}^\circ - P\bar{v})_P - \sum N_R (\bar{h}_f^\circ + \bar{h} - \bar{h}^\circ - P\bar{v})_R$$

Since both the reactants and products are assumed to be ideal gases, all the internal energy and enthalpies depend on temperature only, and the $P\bar{v}$ terms in this equation can be replaced by $R_u T$. It yields

$$-Q_{\text{out}} = \sum N_P (\bar{h}_f^\circ + \bar{h}_{1200 \text{ K}} - \bar{h}_{298 \text{ K}} - R_u T)_P - \sum N_R (\bar{h}_f^\circ - R_u T)_R$$

since the reactants are at the standard reference temperature of 25°C. From the tables,

Substance	\bar{h}_f° kJ/kmol	$\bar{h}_{298 \text{ K}}$ kJ/kmol	$\bar{h}_{1200 \text{ K}}$ kJ/kmol
CH_4	-74,850	---	---
O_2	0	8682	38,447
$\text{H}_2\text{O} (g)$	-241,820	9904	44,380
CO_2	-393,520	9364	53,848

Thus,

$$\begin{aligned} -Q_{\text{out}} &= (7.5)(-393,520 + 53,848 - 9364 - 8.314 \times 1200) \\ &\quad + (15)(-241,820 + 44,380 - 9904 - 8.314 \times 1200) \\ &\quad + (3.75)(0 + 38,447 - 8682 - 8.314 \times 1200) \\ &\quad - (7.5)(-74,850 - 8.314 \times 298) - (18.75)(-8.314 \times 298) \\ &= -5,251,791 \text{ J} = \mathbf{-5252 \text{ kJ}} \end{aligned}$$

Thus $Q_{\text{out}} = \mathbf{5252 \text{ kJ}}$ of heat is transferred from the combustion chamber as 120 g of CH_4 burned in this combustion chamber.

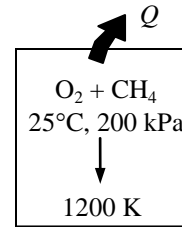



15-66 Problem 15-65 is reconsidered. The effect of the final temperature on the final pressure and the heat transfer for the combustion process is to be investigated.

Analysis The problem is solved using EES, and the solution is given below.

"Input Data"

T_reac = (25+273) "[K]" "reactant mixture temperature"
 P_reac = 200 [kPa] "reactant mixture pressure"
 {T_prod = 1200 [K]} "product mixture temperature"
 m_O2=0.600 [kg] "initial mass of O2"
 Mw_O2 = 32 [kg/kmol]
 m_CH4 = 0.120 [kg] "initial mass of CH4"
 Mw_CH4=(1*12+4*1) "[kg/kmol]"
 R_u = 8.314 [kJ/kmol-K] "universal gas constant"

"For theoretical oxygen, the complete combustion equation is"

"CH4 + A_th O2=1 CO2+2 H2O "

2*A_th=1*2+2*1"theoretical O balance"

"now to find the actual moles of O2 supplied per mole of fuel"

N_O2 = m_O2/Mw_O2/N_CH4

N_CH4= m_CH4/Mw_CH4

"The balanced complete combustion equation with Ex% excess O2 is"

"CH4 + (1+EX) A_th O2=1 CO2+ 2 H2O + Ex(A_th) O2 "

N_O2 = (1+Ex)*A_th

"Apply First Law to the closed system combustion chamber and assume ideal gas behavior. (At 1200 K, water exists in the gas phase.)"

E_in - E_out = DELTAE_sys

E_in = 0

E_out = Q_out "kJ/kmol_CH4" "No work is done because volume is constant"

DELTA E_sys = U_prod - U_reac "neglect KE and PE and note: U = H - PV = N(h - R_u T)"

U_reac = 1*(enthalpy(CH4, T=T_reac) - R_u*T_reac) +(1+EX)*A_th*(enthalpy(O2, T=T_reac) - R_u*T_reac)

U_prod = 1*(enthalpy(CO2, T=T_prod) - R_u*T_prod) +2*(enthalpy(H2O, T=T_prod) - R_u*T_prod)

+EX*A_th*(enthalpy(O2, T=T_prod) - R_u*T_prod)

"The total heat transfer out, in kJ, is:"

Q_out_tot=Q_out"kJ/kmol_CH4"/(Mw_CH4 "kg/kmol_CH4") *m_CH4"kg" "kJ"

"The final pressure in the tank is the pressure of the product gases. Assuming ideal gas behavior for the gases in the constant volume tank, the ideal gas law gives:"

P_reac*V=N_reac * R_u *T_reac

P_prod*V = N_prod * R_u * T_prod

N_reac = N_CH4*(1 + N_O2)

N_prod = N_CH4*(1 + 2 + Ex*A_th)

T _{prod} [K]	Q _{out,tot} [kJ]	P _{prod} [kPa]
500	5872	335.6
700	5712	469.8
900	5537	604
1100	5349	738.3
1300	5151	872.5
1500	4943	1007

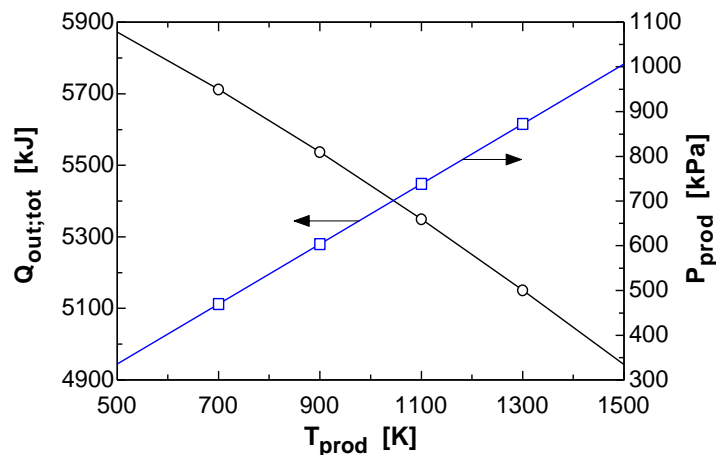

15-67E Methane is burned with stoichiometric amount of air in a rigid container. The heat rejected from the container is to be determined.

Assumptions 1 Air and combustion gases are ideal gases. **2** Combustion is complete.

Properties The molar masses of CH₄ and air are 16 lbm/lbmol and 29 lbm/lbmol, respectively (Table A-1E).

Analysis The combustion equation for 1 lbmol of fuel is

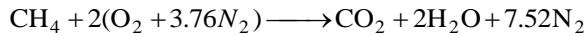

The heat transfer for this constant volume combustion process is determined from the energy balance $E_{\text{in}} - E_{\text{out}} = \Delta E_{\text{system}}$ applied on the combustion chamber with $W = 0$. It reduces to

$$-Q_{\text{out}} = \sum N_P (\bar{h}_f^\circ + \bar{h} - \bar{h}^\circ - P\bar{v})_P - \sum N_R (\bar{h}_f^\circ + \bar{h} - \bar{h}^\circ - P\bar{v})_R$$

Since both the reactants and products are assumed to be ideal gases, all the internal energy and enthalpies depend on temperature only, and the $P\bar{v}$ terms in this equation can be replaced by $R_u T$. It yields

$$-Q_{\text{out}} = \sum N_P (\bar{h}_f^\circ + \bar{h}_{1520R} - \bar{h}_{537R} - R_u T)_P - \sum N_R (\bar{h}_f^\circ - R_u T)_R$$

since the reactants are at the standard reference temperature of 77°F. From the tables,

Substance	\bar{h}_f° Btu/lbmol	\bar{h}_{537R} Btu/lbmol	\bar{h}_{1260R} Btu/lbmol
CH ₄	-32,210	---	---
O ₂	0	3725.1	9096.7
N ₂	0	3729.5	8859.3
H ₂ O (g)	-104,040	4258.0	10,354.9
CO ₂	-169,300	4027.5	11,661.0

Thus,

$$\begin{aligned} -Q_{\text{out}} &= (1)(-169,300 + 11,661.0 - 4027.5 - 1.9858 \times 1260) \\ &\quad + (2)(-104,040 + 10,354.9 - 4258.0 - 1.9858 \times 1260) \\ &\quad + (7.52)(0 + 8859.3 - 3729.5 - 1.9858 \times 1260) \\ &\quad - (1)(-32,210 - 1.9858 \times 537) - (2)(-1.9858 \times 537) - (7.52)(-1.9858 \times 537) \\ &= -301,900 \text{ Btu/lbmol CH}_4 \end{aligned}$$

Thus

$$Q_{\text{out}} = \mathbf{301,900 \text{ Btu/lbmol CH}_4}$$

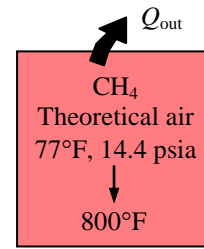

15-68 A stoichiometric mixture of octane gas and air contained in a closed combustion chamber is ignited. The heat transfer from the combustion chamber is to be determined.

Assumptions 1 Both the reactants and products are ideal gases. **2** Combustion is complete.

Analysis The theoretical combustion equation of C_8H_{18} with stoichiometric amount of air is

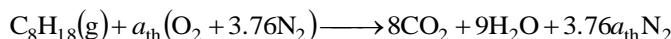

where a_{th} is the stoichiometric coefficient and is determined from the O_2 balance,

$$a_{th} = 8 + 4.5 = 12.5$$

Thus,

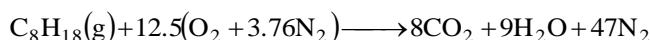

The heat transfer for this constant volume combustion process is determined from the energy balance $E_{in} - E_{out} = \Delta E_{system}$ applied on the combustion chamber with $W_{other} = 0$,

$$-Q_{out} = \sum N_P(\bar{h}_f^\circ + \bar{h} - \bar{h}^\circ - P\bar{v})_P - \sum N_R(\bar{h}_f^\circ + \bar{h} - \bar{h}^\circ - P\bar{v})_R$$

For a constant pressure quasi-equilibrium process $\Delta U + W_b = \Delta H$. Then the first law relation in this case is

$$-Q_{out} = \sum N_P(\bar{h}_f^\circ + \bar{h}_{1000K} - \bar{h}_{298K})_P - \sum N_R\bar{h}_{f,R}^\circ$$

since the reactants are at the standard reference temperature of 25°C . Since both the reactants and the products behave as ideal gases, we have $h = h(T)$. From the tables,

Substance	\bar{h}_f° kJ/kmol	$\bar{h}_{298\text{ K}}$ kJ/kmol	$\bar{h}_{1000\text{ K}}$ kJ/kmol
$C_8H_{18}(g)$	-208,450	---	---
O_2	0	8682	31,389
N_2	0	8669	30,129
$H_2O(g)$	-241,820	9904	35,882
CO_2	-393,520	9364	42,769

Thus,

$$\begin{aligned} -Q_{out} &= (8)(-393,520 + 42,769 - 9364) + (9)(-241,820 + 35,882 - 9904) \\ &\quad + (47)(0 + 30,129 - 8669) - (1)(-208,450) - 0 - 0 \\ &= -3,606,428 \text{ kJ (per kmol of } C_8H_{18}) \end{aligned}$$

or $Q_{out} = 3,606,428 \text{ kJ (per kmol of } C_8H_{18})$.

Total mole numbers initially present in the combustion chamber is determined from the ideal gas relation,

$$N_1 = \frac{P_1 V_1}{R_u T_1} = \frac{(300 \text{ kPa})(0.5 \text{ m}^3)}{(8.314 \text{ kPa} \cdot \text{m}^3/\text{kmol} \cdot \text{K})(298 \text{ K})} = 0.06054 \text{ kmol}$$

Of these, $0.06054 / (1 + 12.5 \times 4.76) = 1.001 \times 10^{-3}$ kmol of them is C_8H_{18} . Thus the amount of heat transferred from the combustion chamber as 1.001×10^{-3} kmol of C_8H_{18} is burned is

$$Q_{out} = (1.001 \times 10^{-3} \text{ kmol } C_8H_{18})(3,606,428 \text{ kJ/kmol } C_8H_{18}) = \mathbf{3610 \text{ kJ}}$$

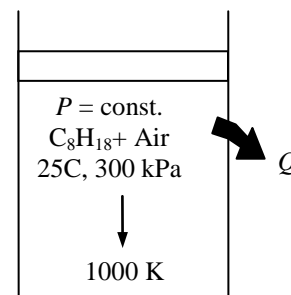

15-69 A high efficiency gas furnace burns gaseous propane C_3H_8 with 140 percent theoretical air. The volume flow rate of water condensed from the product gases is to be determined.

Assumptions 1 Combustion is complete. **2** The combustion products contain CO_2 , H_2O , O_2 , and N_2 only.

Properties The molar masses of C, H_2 , O_2 and air are 12 kg/kmol, 2 kg/kmol, 32 kg/kmol, and 29 kg/kmol, respectively (Table A-1).

Analysis The reaction equation for 40% excess air (140% theoretical air) is

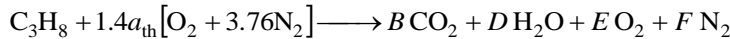

where a_{th} is the stoichiometric coefficient for air. We have automatically accounted for the 40% excess air by using the factor $1.4a_{th}$ instead of a_{th} for air. The coefficient a_{th} and other coefficients are to be determined from the mass balances

$$\text{Carbon balance:} \quad B = 3$$

$$\text{Hydrogen balance:} \quad 2D = 8 \longrightarrow D = 4$$

$$\text{Oxygen balance:} \quad 2 \times 1.4a_{th} = 2B + D + 2E$$

$$0.4a_{th} = E$$

$$\text{Nitrogen balance:} \quad 1.4a_{th} \times 3.76 = F$$

Solving the above equations, we find the coefficients ($E = 2$, $F = 26.32$, and $a_{th} = 5$) and write the balanced reaction equation as

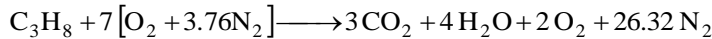

The partial pressure of water in the saturated product mixture at the dew point is

$$P_{v,prod} = P_{sat@40^\circ C} = 7.3851 \text{ kPa}$$

The vapor mole fraction is

$$y_v = \frac{P_{v,prod}}{P_{prod}} = \frac{7.3851 \text{ kPa}}{100 \text{ kPa}} = 0.07385$$

The kmoles of water condensed is determined from

$$y_v = \frac{N_{water}}{N_{total,product}} \longrightarrow 0.07385 = \frac{4 - N_w}{3 + 4 - N_w + 2 + 26.32} \longrightarrow N_w = 1.503 \text{ kmol}$$

The steady-flow energy balance is expressed as

$$\dot{N}_{fuel} H_R = \dot{Q}_{fuel} + \dot{N}_{fuel} H_P$$

where $\dot{Q}_{fuel} = \frac{\dot{Q}_{out}}{\eta_{furnace}} = \frac{31,650 \text{ kJ/h}}{0.96} = 32,969 \text{ kJ/h}$

$$H_R = \bar{h}_{f, fuel@25^\circ C}^o + 7\bar{h}_{O_2@25^\circ C} + 26.32\bar{h}_{N_2@25^\circ C}$$

$$= (-103,847 \text{ kJ/kmol}) + 7(0) + 26.32(0) = -103,847 \text{ kJ/kmol}$$

$$H_P = 3\bar{h}_{CO_2@25^\circ C} + 4\bar{h}_{H_2O@25^\circ C} + 2\bar{h}_{O_2@25^\circ C} + 26.32\bar{h}_{N_2@25^\circ C} + N_w(\bar{h}_{H_2O(liq)}^o)$$

$$= 3(-393,520 \text{ kJ/kmol}) + 4(-241,820 \text{ kJ/kmol}) + 2(0) + 26.32(0) + 1.503(-285,830 \text{ kJ/kmol})$$

$$= -2.577 \times 10^6 \text{ kJ/kmol}$$

Substituting into the energy balance equation,

$$\dot{N}_{fuel} H_R = \dot{Q}_{fuel} + \dot{N}_{fuel} H_P$$

$$\dot{N}_{fuel}(-103,847 \text{ kJ/kmol}) = 32,969 \text{ kJ/h} + \dot{N}_{fuel}(-2.577 \times 10^6 \text{ kJ/kmol}) \longrightarrow \dot{N}_{fuel} = 0.01333 \text{ kmol/h}$$

The molar and mass flow rates of the liquid water are

$$\dot{N}_w = N_w \dot{N}_{fuel} = (1.503 \text{ kmol/kmol fuel})(0.01333 \text{ kmol fuel/h}) = 0.02003 \text{ kmol/h}$$

$$\dot{m}_w = \dot{N}_w M_w = (0.02003 \text{ kmol/h})(18 \text{ kg/kmol}) = 0.3608 \text{ kg/h}$$

The volume flow rate of liquid water is

$$\dot{V}_w = (v_{f@25^\circ C}) \dot{m}_w = (0.001003 \text{ m}^3/\text{kg})(0.3608 \text{ kg/h}) = 0.0003619 \text{ m}^3/\text{h} = \mathbf{8.7 \text{ L/day}}$$

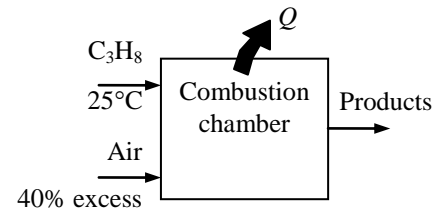

Adiabatic Flame Temperature

15-70C For the case of stoichiometric amount of pure oxygen since we have the same amount of chemical energy released but a smaller amount of mass to absorb it.

15-71C Under the conditions of complete combustion with stoichiometric amount of air.

15-72 Acetylene is burned with stoichiometric amount of oxygen. The adiabatic flame temperature is to be determined.

Assumptions 1 Steady operating conditions exist. **2** Air and combustion gases are ideal gases. **3** Kinetic and potential energies are negligible. **4** There are no work interactions. **5** The combustion chamber is adiabatic.

Analysis Under steady-flow conditions the energy balance $E_{\text{in}} - E_{\text{out}} = \Delta E_{\text{system}}$ applied on the combustion chamber with $Q = W = 0$ reduces to

$$\sum N_P (\bar{h}_f^\circ + \bar{h} - \bar{h}^\circ)_P = \sum N_R (\bar{h}_f^\circ + \bar{h} - \bar{h}^\circ)_R \longrightarrow \sum N_P (\bar{h}_f^\circ + \bar{h} - \bar{h}^\circ)_P = \sum N_R \bar{h}_{f,R}^\circ$$

since all the reactants are at the standard reference temperature of 25°C. Then, for the stoichiometric oxygen

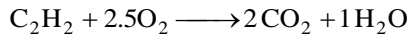

From the tables,

Substance	\bar{h}_f° kJ/kmol	$\bar{h}_{298\text{K}}$ kJ/kmol
C ₂ H ₂ (g)	226,730	---
O ₂	0	8682
N ₂	0	8669
H ₂ O (g)	-241,820	9904
CO ₂	-393,520	9364

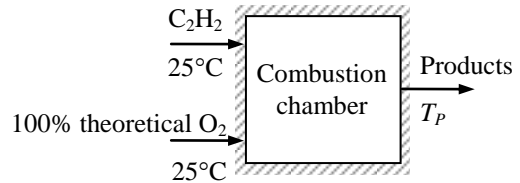

Thus,

$$(2)(-393,520 + \bar{h}_{\text{CO}_2} - 9364) + (1)(-241,820 + \bar{h}_{\text{H}_2\text{O}} - 9904) = (1)(226,730) + 0 + 0$$

It yields $2\bar{h}_{\text{CO}_2} + \bar{h}_{\text{H}_2\text{O}} = 1,284,220 \text{ kJ}$

The adiabatic flame temperature is obtained from a trial and error solution. A first guess is obtained by dividing the right-hand side of the equation by the total number of moles, which yields $2,284,220/(2+1) = 428,074 \text{ kJ/kmol}$. The ideal gas tables do not list enthalpy values this high. Therefore, we cannot use the tables to estimate the adiabatic flame temperature. In Table A-2b, the highest available value of specific heat is $c_p = 1.234 \text{ kJ/kg}\cdot\text{K}$ for CO₂ at 1000 K. The specific heat of water vapor is $c_p = 1.8723 \text{ kJ/kg}\cdot\text{K}$ (Table A-2a). Using these specific heat values,

$$(2)(-393,520 + \bar{c}_p \Delta T) + (1)(-241,820 + \bar{c}_p \Delta T) = (1)(226,730) + 0 + 0$$

where $\Delta T = (T_{\text{af}} - 25)^\circ\text{C}$. The specific heats on a molar base are

$$\bar{c}_{p,\text{CO}_2} = \bar{c}_p M = (1.234 \text{ kJ/kg}\cdot\text{K})(44 \text{ kg/kmol}) = 54.3 \text{ kJ/kmol}\cdot\text{K}$$

$$\bar{c}_{p,\text{H}_2\text{O}} = \bar{c}_p M = (1.8723 \text{ kJ/kg}\cdot\text{K})(18 \text{ kg/kmol}) = 33.7 \text{ kJ/kmol}\cdot\text{K}$$

Substituting,

$$(2)(-393,520 + 54.3\Delta T) + (1)(-241,820 + 33.7\Delta T) = 226,730$$

$$(2 \times 54.3)\Delta T + 33.7\Delta T = 1,255,590$$

$$\Delta T = \frac{1,255,590 \text{ kJ/kmol}}{(2 \times 54.3 + 33.7) \text{ kJ/kmol}\cdot\text{K}} = 8824 \text{ K}$$

Then the adiabatic flame temperature is estimated as

$$T_{\text{af}} = \Delta T + 25 = 8824 + 25 = \mathbf{8849^\circ\text{C}}$$

15-73 Propane is burned with stoichiometric and 50 percent excess air. The adiabatic flame temperature is to be determined for both cases.

Assumptions 1 Steady operating conditions exist. **2** Air and combustion gases are ideal gases. **3** Kinetic and potential energies are negligible. **4** There are no work interactions. **5** The combustion chamber is adiabatic.

Analysis Under steady-flow conditions the energy balance $E_{\text{in}} - E_{\text{out}} = \Delta E_{\text{system}}$ applied on the combustion chamber with $Q = W = 0$ reduces to

$$\sum N_P (\bar{h}_f^\circ + \bar{h} - \bar{h}^\circ)_P = \sum N_R (\bar{h}_f^\circ + \bar{h} - \bar{h}^\circ)_R \longrightarrow \sum N_P (\bar{h}_f^\circ + \bar{h} - \bar{h}^\circ)_P = \sum N_R \bar{h}_{f,R}^\circ$$

since all the reactants are at the standard reference temperature of 25°C. Then, for the stoichiometric air

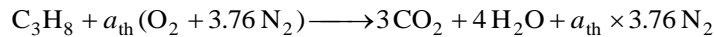

where a_{th} is the stoichiometric coefficient and is determined from the O_2 balance,

$$a_{\text{th}} = 3 + 2 = 5$$

Thus,

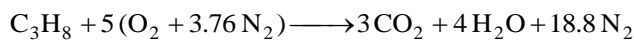

From the tables,

Substance	\bar{h}_f° kJ/kmol	$\bar{h}_{298\text{K}}$ kJ/kmol
$\text{C}_3\text{H}_8(g)$	-103,850	---
O_2	0	8682
N_2	0	8669
$\text{H}_2\text{O}(g)$	-241,820	9904
CO_2	-393,520	9364

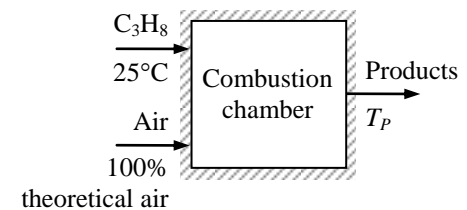

Thus,

$$(3)(-393,520 + \bar{h}_{\text{CO}_2} - 9364) + (4)(-241,820 + \bar{h}_{\text{H}_2\text{O}} - 9904) + (18.8)(0 + \bar{h}_{\text{N}_2} - 8669) = (1)(-103,850) + 0 + 0$$

It yields $3\bar{h}_{\text{CO}_2} + 4\bar{h}_{\text{H}_2\text{O}} + 18.8\bar{h}_{\text{N}_2} = 2,274,680 \text{ kJ}$

The adiabatic flame temperature is obtained from a trial and error solution. A first guess is obtained by dividing the right-hand side of the equation by the total number of moles, which yields $2,274,680/(3 + 4 + 18.8) = 88,166 \text{ kJ/kmol}$. This enthalpy value corresponds to about 2650 K for N_2 . Noting that the majority of the moles are N_2 , T_P will be close to 2650 K, but somewhat under it because of the higher specific heat of H_2O .

At 2500 K:

$$\begin{aligned} 3\bar{h}_{\text{CO}_2} + 4\bar{h}_{\text{H}_2\text{O}} + 18.8\bar{h}_{\text{N}_2} &= 3 \times 131,290 + 4 \times 108,868 + 18.8 \times 82,981 \\ &= 2,389,380 \text{ kJ (Higher than 2,274,680 kJ)} \end{aligned}$$

At 2450 K:

$$\begin{aligned} 3\bar{h}_{\text{CO}_2} + 4\bar{h}_{\text{H}_2\text{O}} + 18.8\bar{h}_{\text{N}_2} &= 3 \times 128,219 + 4 \times 106,183 + 18.8 \times 81,149 \\ &= 2,334,990 \text{ kJ (Higher than 2,274,680 kJ)} \end{aligned}$$

At 2400 K:

$$\begin{aligned} 3\bar{h}_{\text{CO}_2} + 4\bar{h}_{\text{H}_2\text{O}} + 18.8\bar{h}_{\text{N}_2} &= 3 \times 125,152 + 4 \times 103,508 + 18.8 \times 79,320 \\ &= 2,280,704 \text{ kJ (Higher than 2,274,680 kJ)} \end{aligned}$$

At 2350 K:

$$3\bar{h}_{\text{CO}_2} + 4\bar{h}_{\text{H}_2\text{O}} + 18.8\bar{h}_{\text{N}_2} = 3 \times 122,091 + 4 \times 100,846 + 18.8 \times 77,496 \\ = 2,226,580 \text{ kJ (Lower than 2,274,680 kJ)}$$

By interpolation of the two results,

$$T_p = \mathbf{2394 \text{ K} = 2121^\circ\text{C}}$$

When propane is burned with 20% excess air, the reaction equation may be written as

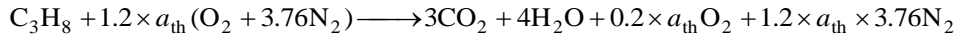

where a_{th} is the stoichiometric coefficient and is determined from the O_2 balance,

$$1.2a_{\text{th}} = 3 + 2 + 0.2a_{\text{th}} \longrightarrow a_{\text{th}} = 5$$

Thus,

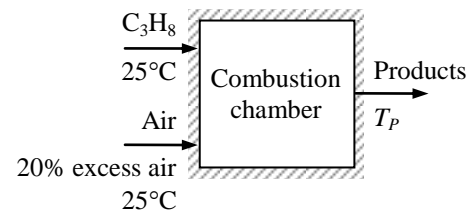
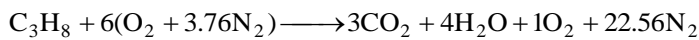

Using the values in the table,

$$(3)(-393,520 + \bar{h}_{\text{CO}_2} - 9364) + (4)(-241,820 + \bar{h}_{\text{H}_2\text{O}} - 9904) + (1)(0 + \bar{h}_{\text{O}_2} - 8682) \\ + (22.56)(0 + \bar{h}_{\text{N}_2} - 8669) = (1)(-103,850) + 0 + 0$$

It yields

$$3\bar{h}_{\text{CO}_2} + 4\bar{h}_{\text{H}_2\text{O}} + 1\bar{h}_{\text{O}_2} + 22.56\bar{h}_{\text{N}_2} = 2,315,950 \text{ kJ}$$

The adiabatic flame temperature is obtained from a trial and error solution. A first guess is obtained by dividing the right-hand side of the equation by the total number of moles, which yields $2,315,950/(3+4+1+22.56) = 75,784 \text{ kJ/kmol}$. This enthalpy value corresponds to about 2300 K for N_2 . Noting that the majority of the moles are N_2 , T_p will be close to 2300 K, but somewhat under it because of the higher specific heat of H_2O .

At 2100 K:

$$3\bar{h}_{\text{CO}_2} + 4\bar{h}_{\text{H}_2\text{O}} + 1\bar{h}_{\text{O}_2} + 22.56\bar{h}_{\text{N}_2} = 3 \times 106,864 + 4 \times 87,735 + 1 \times 71,668 + 22.56 \times 68,417 \\ = 2,286,690 \text{ kJ (Lower than 2,315,950 kJ)}$$

At 2150 K:

$$3\bar{h}_{\text{CO}_2} + 4\bar{h}_{\text{H}_2\text{O}} + 1\bar{h}_{\text{O}_2} + 22.56\bar{h}_{\text{N}_2} = 3 \times 109,898 + 4 \times 90,330 + 1 \times 73,573 + 22.56 \times 70,226 \\ = 2,348,890 \text{ kJ (Higher than 2,315,950 kJ)}$$

By interpolation,

$$T_p = 2124 \text{ K} = \mathbf{1851^\circ\text{C}}$$

15-74 Acetylene gas is burned with 30 percent excess air during a steady-flow combustion process. The exit temperature of product gases is to be determined.

Assumptions 1 Steady operating conditions exist. 2 Air and combustion gases are ideal gases. 3 Kinetic and potential energies are negligible. 4 There are no work interactions.

Analysis The fuel is burned completely with the excess air, and thus the products will contain only CO_2 , H_2O , N_2 , and some free O_2 . Considering 1 kmol of C_2H_2 , the combustion equation can be written as

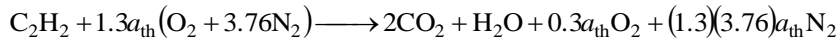

where a_{th} is the stoichiometric coefficient and is determined from the O_2 balance,

$$1.3a_{\text{th}} = 2 + 0.5 + 0.3a_{\text{th}} \longrightarrow a_{\text{th}} = 2.5$$

Thus,

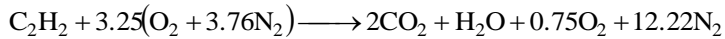

Under steady-flow conditions the energy balance

$E_{\text{in}} - E_{\text{out}} = \Delta E_{\text{system}}$ applied on the combustion chamber with

$W = 0$ reduces to

$$-Q_{\text{out}} = \sum N_P (\bar{h}_f^\circ + \bar{h} - \bar{h}^\circ)_P - \sum N_R (\bar{h}_f^\circ + \bar{h} - \bar{h}^\circ)_R$$

Assuming the air and the combustion products to be ideal gases, we have $h = h(T)$. From the tables,

Substance	\bar{h}_f° kJ/kmol	$\bar{h}_{298\text{ K}}$ kJ/kmol	$\bar{h}_{300\text{ K}}$ kJ/kmol
C_2H_2	226,730	---	---
O_2	0	8682	8736
N_2	0	8669	8723
$\text{H}_2\text{O} (g)$	-241,820	9904	---
CO_2	-393,520	9364	---

Thus,

$$\begin{aligned} -75,000 &= (2)(-393,520 + \bar{h}_{\text{CO}_2} - 9364) + (1)(-241,820 + \bar{h}_{\text{H}_2\text{O}} - 9904) \\ &+ (0.75)(0 + \bar{h}_{\text{O}_2} - 8682) + (12.22)(0 + \bar{h}_{\text{N}_2} - 8669) - (1)(226,730) \\ &- (3.25)(0 + 8736 - 8682) + (12.22)(0 + 8723 - 8669) \end{aligned}$$

It yields

$$2\bar{h}_{\text{CO}_2} + \bar{h}_{\text{H}_2\text{O}} + 0.75\bar{h}_{\text{O}_2} + 12.22\bar{h}_{\text{N}_2} = 1,321,184 \text{ kJ}$$

The temperature of the product gases is obtained from a trial and error solution. A first guess is obtained by dividing the right-hand side of the equation by the total number of moles, which yields $1,321,184 / (2 + 1 + 0.75 + 12.22) = 82,729$ kJ/kmol. This enthalpy value corresponds to about 2500 K for N_2 . Noting that the majority of the moles are N_2 , T_P will be close to 2500 K, but somewhat under it because of the higher specific heats of CO_2 and H_2O .

At 2350 K:

$$\begin{aligned} 2\bar{h}_{\text{CO}_2} + \bar{h}_{\text{H}_2\text{O}} + 0.75\bar{h}_{\text{O}_2} + 12.22\bar{h}_{\text{N}_2} &= (2)(122,091) + (1)(100,846) + (0.75)(81,243) + (12.22)(77,496) \\ &= 1,352,961 \text{ kJ (Higher than 1,321,184 kJ)} \end{aligned}$$

At 2300 K:

$$\begin{aligned} 2\bar{h}_{\text{CO}_2} + \bar{h}_{\text{H}_2\text{O}} + 0.75\bar{h}_{\text{O}_2} + 12.22\bar{h}_{\text{N}_2} &= (2)(119,035) + (1)(98,199) + (0.75)(79,316) + (12.22)(75,676) \\ &= 1,320,517 \text{ kJ (Lower than 1,321,184 kJ)} \end{aligned}$$

By interpolation,

$$T_P = \mathbf{2301 \text{ K}}$$

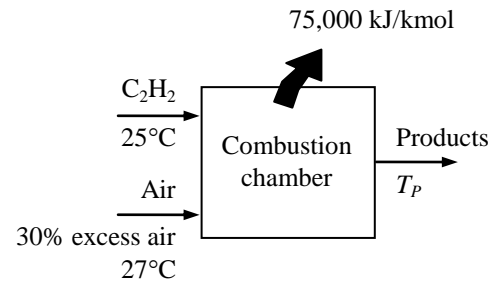

15-75 Octane gas is burned with 30 percent excess air during a steady-flow combustion process. The exit temperature of product gases is to be determined.

Assumptions 1 Steady operating conditions exist. 2 Air and combustion gases are ideal gases. 3 Kinetic and potential energies are negligible. 4 There are no work interactions. 5 The combustion chamber is adiabatic.

Analysis Under steady-flow conditions the energy balance $E_{in} - E_{out} = \Delta E_{system}$ applied on the combustion chamber with $Q = W = 0$ reduces to

$$\sum N_P (\bar{h}_f^\circ + \bar{h} - \bar{h}^\circ)_P = \sum N_R (\bar{h}_f^\circ + \bar{h} - \bar{h}^\circ)_R \longrightarrow \sum N_P (\bar{h}_f^\circ + \bar{h} - \bar{h}^\circ)_P = \sum N_R \bar{h}_{f,R}^\circ$$

since all the reactants are at the standard reference temperature of 25°C. Then,



where a_{th} is the stoichiometric coefficient and is determined from the O_2 balance,

$$1.3a_{\text{th}} = 8 + 4.5 + 0.3a_{\text{th}} \longrightarrow a_{\text{th}} = 12.5$$

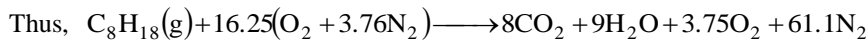

Therefore, $16.25 \times 4.76 = 77.35$ kmol of dry air will be used per kmol of the fuel. The partial pressure of the water vapor present in the incoming air is

$$P_{v,\text{in}} = \phi_{\text{air}} P_{\text{sat}@25^\circ\text{C}} = (0.60)(3.1698 \text{ kPa}) = 1.902 \text{ kPa}$$

Assuming ideal gas behavior, the number of moles of the moisture that accompanies 77.35 kmol of incoming dry air is determined to be

$$N_{v,\text{in}} = \left(\frac{P_{v,\text{in}}}{P_{\text{total}}} \right) N_{\text{total}} = \left(\frac{1.902 \text{ kPa}}{101.325 \text{ kPa}} \right) (77.35 + N_{v,\text{in}}) \longrightarrow N_{v,\text{in}} = 1.48 \text{ kmol}$$

The balanced combustion equation is obtained by adding 1.48 kmol of H_2O to both sides of the equation,

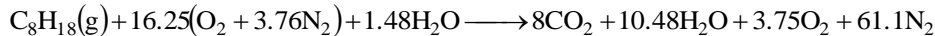

From the tables,

Substance	\bar{h}_f° kJ/kmol	$\bar{h}_{298 \text{ K}}$ kJ/kmol
$\text{C}_8\text{H}_{18}(\text{g})$	-208,450	---
O_2	0	8682
N_2	0	8669
$\text{H}_2\text{O}(\text{g})$	-241,820	9904
CO_2	-393,520	9364

Thus,

$$(8)(-393,520 + \bar{h}_{\text{CO}_2}) + (10.48)(-241,820 + \bar{h}_{\text{H}_2\text{O}}) + (3.75)(0 + \bar{h}_{\text{O}_2} - 8682) + (61.1)(0 + \bar{h}_{\text{N}_2} - 8669) = (1)(-208,450) + (1.48)(-241,820) + 0 + 0$$

$$\text{It yields } 8\bar{h}_{\text{CO}_2} + 10.48\bar{h}_{\text{H}_2\text{O}} + 3.75\bar{h}_{\text{O}_2} + 61.1\bar{h}_{\text{N}_2} = 5,857,029 \text{ kJ}$$

The adiabatic flame temperature is obtained from a trial and error solution. A first guess is obtained by dividing the right-hand side of the equation by the total number of moles, which yields $5,857,029 / (8 + 10.48 + 3.75 + 61.1) = 70,287$ kJ/kmol. This enthalpy value corresponds to about 2150 K for N_2 . Noting that the majority of the moles are N_2 , T_P will be close to 2150 K, but somewhat under it because of the higher specific heat of H_2O .

At 2000 K:

$$8\bar{h}_{\text{CO}_2} + 10.48\bar{h}_{\text{H}_2\text{O}} + 3.75\bar{h}_{\text{O}_2} + 61.1\bar{h}_{\text{N}_2} = (8)(100,804) + (10.48)(82,593) + (3.75)(67,881) + (61.1)(64,810) = 5,886,451 \text{ kJ (Higher than 5,857,029 kJ)}$$

At 1980 K:

$$8\bar{h}_{\text{CO}_2} + 10.48\bar{h}_{\text{H}_2\text{O}} + 3.75\bar{h}_{\text{O}_2} + 61.1\bar{h}_{\text{N}_2} = (8)(99,606) + (10.48)(81,573) + (3.75)(67,127) + (61.1)(64,090) = 5,819,358 \text{ kJ (Lower than 5,857,029 kJ)}$$

By interpolation, $T_P = 1991 \text{ K}$

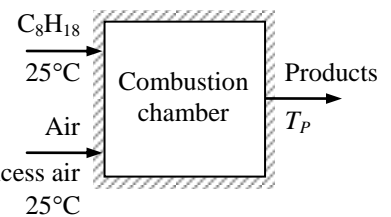



15-76 Problem 15-75 is reconsidered. The effect of the relative humidity on the exit temperature of the product gases is to be investigated.

Analysis The problem is solved using EES, and the solution is given below.

"The percent excess air and relative humidity are input by the diagram window."

{PercentEX = 30["%"]}

{RelHum=60["%"]}

"Other input data:"

Fuel\$ = 'Octane (C8H18)'

T_fuel = (25+273) "[K]"

Ex = PercentEX/100 "[%Excess air/100]"

P_air1 = 101.3 [kPa]

T_air1 = 25+273 "[K]"

RH_1 = RelHum/100

M_air = 28.97 [kg/kmol]

M_water = 18 [kg/kmol]

M_C8H18=(8*12+18*1) "[kg/kmol]"

"For theoretical dry air, the complete combustion equation is"

"C8H18 + A_th(O2+3.76 N2)=8 CO2+9 H2O + A_th (3.76) N2 "

A_th*2=8*2+9*1 "theoretical O balance"

"now to find the amount of water vapor associated with the dry air"

w_1=HUMRAT(AirH2O,T=T_air1,P=P_air1,R=RH_1) "Humidity ratio, kgv/kg"

N_w=w_1*((1+Ex)*A_th*4.76*M_air)/M_water "Moles of water in the atmospheric air, kmol/kmol_fuel"

"The balanced combustion equation with Ex% excess moist air is"

"C8H18 + (1+EX)[A_th(O2+3.76 N2)+N_w H2O]=8 CO2+(9+N_w) H2O + (1+Ex) A_th (3.76) N2+ Ex (A_th) O2 "

"Apply First Law SSSF"

H_fuel = -208450 [kJ/kmol] "from Table A-26"

HR=H_fuel+ (1+Ex)*A_th*enthalpy(O2,T=T_air1)+(1+Ex)*A_th*3.76

*enthalpy(N2,T=T_air1)+N_w*enthalpy(H2O,T=T_air1)

HP=8*enthalpy(CO2,T=T_prod)+(9+N_w)*enthalpy(H2O,T=T_prod)+(1+Ex)*A_th*3.76*

enthalpy(N2,T=T_prod)+Ex*A_th*enthalpy(O2,T=T_prod)

"For Adiabatic Combustion:"

HP = HR

"This solution used the humidity ratio from psychrometric data to determine the moles of water vapor in atmospheric air. One should calculate the moles of water contained in the atmospheric air by the method shown in Chapter 14, which uses the relative humidity to find the partial pressure of the water vapor and, thus, the moles of water vapor. Explore what happens to the results as you vary the percent excess air, relative humidity, and product temperature. "

RelHum [%]	T _{prod} [K]
0	2024
10	2019
20	2014
30	2008
40	2003
50	1997
60	1992
70	1987
80	1981
90	1976
100	1971

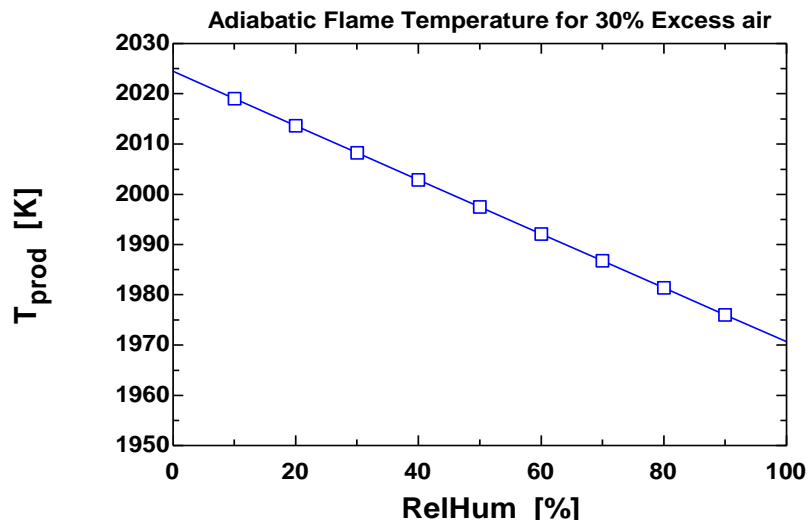

15-77 A certain coal is burned with 100 percent excess air adiabatically during a steady-flow combustion process. The temperature of product gases is to be determined for complete combustion and incomplete combustion cases.

Assumptions 1 Steady operating conditions exist. **2** Air and combustion gases are ideal gases. **3** Kinetic and potential energies are negligible. **4** There are no work interactions. **5** The combustion chamber is adiabatic.

Properties The molar masses of C, H₂, N₂, O₂, S, and air are 12, 2, 28, 32, 32, and 29 kg/kmol, respectively (Table A-1).

Analysis We consider 100 kg of coal for simplicity. Noting that the mass percentages in this case correspond to the masses of the constituents, the mole numbers of the constituent of the coal are determined to be

$$N_C = \frac{m_C}{M_C} = \frac{84.36 \text{ kg}}{12 \text{ kg/kmol}} = 7.03 \text{ kmol}$$

$$N_{H_2} = \frac{m_{H_2}}{M_{H_2}} = \frac{1.89 \text{ kg}}{2 \text{ kg/kmol}} = 0.945 \text{ kmol}$$

$$N_{O_2} = \frac{m_{O_2}}{M_{O_2}} = \frac{4.40 \text{ kg}}{32 \text{ kg/kmol}} = 0.1375 \text{ kmol}$$

$$N_{N_2} = \frac{m_{N_2}}{M_{N_2}} = \frac{0.63 \text{ kg}}{28 \text{ kg/kmol}} = 0.0225 \text{ kmol}$$

$$N_S = \frac{m_S}{M_S} = \frac{0.89 \text{ kg}}{32 \text{ kg/kmol}} = 0.0278 \text{ kmol}$$

84.36% C
1.89% H ₂
4.40% O ₂
0.63% N ₂
0.89% S
7.83% ash (by mass)

The mole number of the mixture and the mole fractions are

$$N_m = 7.03 + 0.945 + 0.1375 + 0.0225 + 0.0278 = 8.163 \text{ kmol}$$

$$y_C = \frac{N_C}{N_m} = \frac{7.03 \text{ kmol}}{8.163 \text{ kmol}} = 0.8611$$

$$y_{H_2} = \frac{N_{H_2}}{N_m} = \frac{0.945 \text{ kmol}}{8.163 \text{ kmol}} = 0.1158$$

$$y_{O_2} = \frac{N_{O_2}}{N_m} = \frac{0.1375 \text{ kmol}}{8.163 \text{ kmol}} = 0.01684$$

$$y_{N_2} = \frac{N_{N_2}}{N_m} = \frac{0.0225 \text{ kmol}}{8.163 \text{ kmol}} = 0.00276$$

$$y_S = \frac{N_S}{N_m} = \frac{0.0278 \text{ kmol}}{8.163 \text{ kmol}} = 0.003407$$

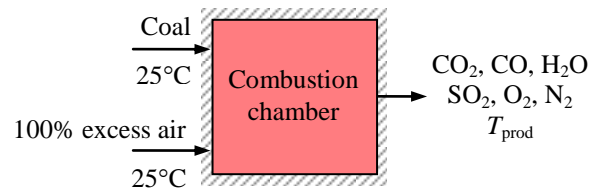

Ash consists of the non-combustible matter in coal. Therefore, the mass of ash content that enters the combustion chamber is equal to the mass content that leaves. Disregarding this non-reacting component for simplicity, the combustion equation may be written as

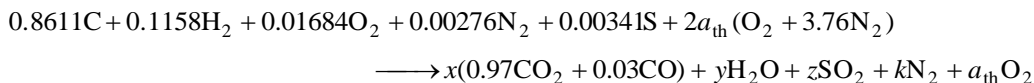

According to the species balances,

$$\text{C balance: } x = 0.8611$$

$$\text{H}_2 \text{ balance: } y = 0.1158$$

$$\text{S balance: } z = 0.00341$$

$$\text{O}_2 \text{ balance:}$$

$$0.01684 + 2a_{th} = 0.97x + 0.015x + 0.5y + z + a_{th}$$

$$a_{th} = (0.97)(0.8611) + (0.015)(0.8611) + (0.5)(0.1158) + 0.00341 - 0.01684 = 0.8927$$

$$\text{N}_2 \text{ balance: } 0.00276 + 2 \times 3.76a_{th} = k \longrightarrow k = 0.00276 + 2 \times 3.76 \times 0.8927 = 6.72$$

Substituting,

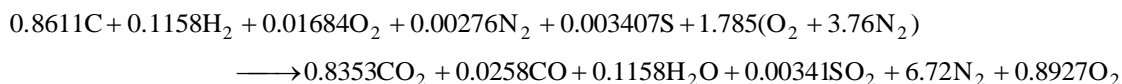

Under steady-flow conditions the energy balance $E_{\text{in}} - E_{\text{out}} = \Delta E_{\text{system}}$ applied on the combustion chamber with $Q = W = 0$ reduces to

$$\sum N_P (\bar{h}_f^\circ + \bar{h} - \bar{h}^\circ)_P = \sum N_R (\bar{h}_f^\circ + \bar{h} - \bar{h}^\circ)_R \longrightarrow \sum N_P (\bar{h}_f^\circ + \bar{h} - \bar{h}^\circ)_P = \sum N_R \bar{h}_{f,R}^\circ$$

From the tables,

Substance	\bar{h}_f° kJ/kmol	$\bar{h}_{298\text{K}}$ kJ/kmol
O ₂	0	8682
N ₂	0	8669
H ₂ O (g)	-241,820	9904
CO	-110,530	8669
CO ₂	-110,530	8669

Thus,

$$(0.8353)(-393,520 + \bar{h}_{\text{CO}_2}) + (0.0258)(-110,530 + \bar{h}_{\text{CO}} - 8669) + (0.1158)(-241,820 + \bar{h}_{\text{H}_2\text{O}} - 9904) \\ + (0.8927)(0 + \bar{h}_{\text{O}_2} - 8682) + (6.72)(0 + \bar{h}_{\text{N}_2} - 8669) = 0$$

It yields

$$0.8353\bar{h}_{\text{CO}_2} + 0.0258\bar{h}_{\text{CO}} + 0.1158\bar{h}_{\text{H}_2\text{O}} + 0.8927\bar{h}_{\text{O}_2} + 6.72\bar{h}_{\text{N}_2} = 434,760 \text{ kJ}$$

The product temperature is obtained from a trial and error solution. A first guess is obtained by dividing the right-hand side of the equation by the total number of moles, which yields

$$434,760 / (0.8353 + 0.0258 + 0.1158 + 0.00341 + 6.72 + 0.8927) = 50,595 \text{ kJ/kmol.}$$

This enthalpy value corresponds to about 1600 K for N₂. Noting that the majority of the moles are N₂, T_P will be close to 1600 K, but somewhat under it because of the higher specific heat of H₂O.

At 1500 K:

$$0.8353\bar{h}_{\text{CO}_2} + 0.0258\bar{h}_{\text{CO}} + 0.1158\bar{h}_{\text{H}_2\text{O}} + 0.9095\bar{h}_{\text{O}_2} + 6.842\bar{h}_{\text{N}_2} \\ = (0.8353)(71,078) + (0.0258)(47,517) + (0.1158)(57,999) + (0.8927)(49,292) + (6.72)(47,073) \\ = 427,647 \text{ kJ (Lower than 434,760 kJ)}$$

At 1520 K:

$$0.8353\bar{h}_{\text{CO}_2} + 0.0258\bar{h}_{\text{CO}} + 0.1158\bar{h}_{\text{H}_2\text{O}} + 0.9095\bar{h}_{\text{O}_2} + 6.842\bar{h}_{\text{N}_2} \\ = (0.8353)(72,246) + (0.0258)(48,222) + (0.1158)(58,942) + (0.8927)(50,024) + (6.72)(47,771) \\ = 434,094 \text{ kJ (Lower than 434,760 kJ)}$$

By extrapolation, $T_P = \mathbf{1522 \text{ K} = 1249^\circ\text{C}}$

We repeat the calculations for the complete combustion now:

The combustion equation in this case may be written as

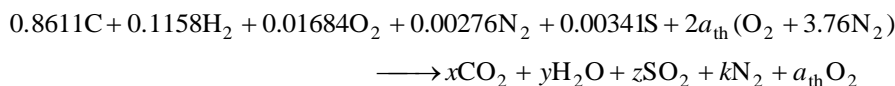

According to the species balances,

C balance : $x = 0.8611$

H₂ balance : $y = 0.1158$

S balance : $z = 0.00341$

O₂ balance :

$$0.01684 + 2a_{\text{th}} = x + 0.5y + z + a_{\text{th}} \longrightarrow a_{\text{th}} = 0.8611 + (0.5)(0.1158) + 0.00341 - 0.01684 = 0.9056$$

$$\text{N}_2 \text{ balance : } 0.00276 + 2 \times 3.76a_{\text{th}} = k \longrightarrow k = 0.00276 + 2 \times 3.76 \times 0.9056 = 6.81$$

Substituting,

$$0.8611\text{C} + 0.1158\text{H}_2 + 0.01684\text{O}_2 + 0.00276\text{N}_2 + 0.003407\text{S} + 1.819(\text{O}_2 + 3.76\text{N}_2) \\ \longrightarrow 0.8611\text{CO}_2 + 0.1158\text{H}_2\text{O} + 0.00341\text{SO}_2 + 6.81\text{N}_2 + 0.9056\text{O}_2$$

Under steady-flow conditions the energy balance $E_{\text{in}} - E_{\text{out}} = \Delta E_{\text{system}}$ applied on the combustion chamber with $Q = W = 0$ reduces to

$$\sum N_P (\bar{h}_f^\circ + \bar{h} - \bar{h}^\circ)_P = \sum N_R (\bar{h}_f^\circ + \bar{h} - \bar{h}^\circ)_R \longrightarrow \sum N_P (\bar{h}_f^\circ + \bar{h} - \bar{h}^\circ)_P = \sum N_R \bar{h}_{f,R}^\circ$$

From the tables,

Substance	\bar{h}_f° kJ/kmol	$\bar{h}_{298\text{K}}$ kJ/kmol
O ₂	0	8682
N ₂	0	8669
H ₂ O (g)	-241,820	9904
CO	-110,530	8669
CO ₂	0	8682

Thus,

$$(0.8611)(-393,520 + \bar{h}_{\text{CO}_2} - 9364) + (0.1158)(-241,820 + \bar{h}_{\text{H}_2\text{O}} - 9904) \\ + (0.9056)(0 + \bar{h}_{\text{O}_2} - 8682) + (6.81)(0 + \bar{h}_{\text{N}_2} - 8669) = 0$$

It yields

$$0.8611\bar{h}_{\text{CO}_2} + 0.1158\bar{h}_{\text{H}_2\text{O}} + 0.9056\bar{h}_{\text{O}_2} + 6.81\bar{h}_{\text{N}_2} = 442,971 \text{ kJ}$$

The product temperature is obtained from a trial and error solution. A first guess is obtained by dividing the right-hand side of the equation by the total number of moles, which yields

$$442,971 / (0.8611 + 0.1158 + 0.00341 + 6.81 + 0.9056) = 50,940 \text{ kJ/kmol.}$$

This enthalpy value corresponds to about 1600 K for N₂. Noting that the majority of the moles are N₂, T_p will be close to 1600 K, but somewhat under it because of the higher specific heat of H₂O.

At 1500 K:

$$0.8611\bar{h}_{\text{CO}_2} + 0.1158\bar{h}_{\text{H}_2\text{O}} + 0.9056\bar{h}_{\text{O}_2} + 6.81\bar{h}_{\text{N}_2} \\ = (0.8611)(71,078) + (0.1158)(57,999) + (0.9056)(49,292) + (6.81)(47,073) \\ = 433,128 \text{ kJ (Lower than 442,971 kJ)}$$

At 1520 K:

$$0.8611\bar{h}_{\text{CO}_2} + 0.1158\bar{h}_{\text{H}_2\text{O}} + 0.9056\bar{h}_{\text{O}_2} + 6.81\bar{h}_{\text{N}_2} \\ = (0.8611)(72,246) + (0.1158)(58,942) + (0.9056)(50,024) + (6.81)(47,771) \\ = 439,658 \text{ kJ (Lower than 442,971 kJ)}$$

By extrapolation, $T_p = \mathbf{1530 \text{ K} = 1257^\circ\text{C}}$

15-78 A mixture of hydrogen and the stoichiometric amount of air contained in a constant-volume tank is ignited. The final temperature in the tank is to be determined.

Assumptions 1 The tank is adiabatic. **2** Both the reactants and products are ideal gases. **3** There are no work interactions. **4** Combustion is complete.

Analysis The combustion equation of H_2 with stoichiometric amount of air is

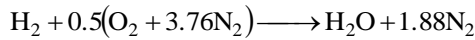

The final temperature in the tank is determined from the energy balance relation $E_{in} - E_{out} = \Delta E_{system}$ for reacting closed systems under adiabatic conditions ($Q = 0$) with no work interactions ($W = 0$),

$$\sum N_P (\bar{h}_f^\circ + \bar{h} - \bar{h}^\circ - P\bar{v})_P = \sum N_R (\bar{h}_f^\circ + \bar{h} - \bar{h}^\circ - P\bar{v})_R$$

Since both the reactants and the products behave as ideal gases, all the internal energy and enthalpies depend on temperature only, and the $P\bar{v}$ terms in this equation can be replaced by $R_u T$.

It yields

$$\sum N_P (\bar{h}_f^\circ + \bar{h}_{T_P} - \bar{h}_{298K} - R_u T)_P = \sum N_R (\bar{h}_f^\circ R_u T)_R$$

since the reactants are at the standard reference temperature of 25°C . From the tables,

Substance	\bar{h}_f°	$\bar{h}_{298\text{ K}}$
	kJ/kmol	kJ/kmol
H_2	0	8468
O_2	0	8682
N_2	0	8669
$H_2O(g)$	-241,820	9904

Thus,

$$\begin{aligned} (1)(-241,820 + \bar{h}_{H_2O} - 9904 - 8.314 \times T_P) + (1.88)(0 + \bar{h}_{N_2} - 8669 - 8.314 \times T_P) \\ = (1)(0 - 8.314 \times 298) + (0.5)(0 - 8.314 \times 298) + (1.88)(0 - 8.314 \times 298) \end{aligned}$$

It yields

$$\bar{h}_{H_2O} + 1.88\bar{h}_{N_2} - 23.94 \times T_P = 259,648 \text{ kJ}$$

The temperature of the product gases is obtained from a trial and error solution,

$$\begin{aligned} \text{At } 3050 \text{ K: } \quad \bar{h}_{H_2O} + 1.88\bar{h}_{N_2} - 23.94 \times T_P &= (1)(139,051) + (1.88)(103,260) - (23.94)(3050) \\ &= 260,163 \text{ kJ (Higher than } 259,648 \text{ kJ)} \end{aligned}$$

$$\begin{aligned} \text{At } 3000 \text{ K: } \quad \bar{h}_{H_2O} + 1.88\bar{h}_{N_2} - 23.94 \times T_P &= (1)(136,264) + (1.88)(101,407) - (23.94)(3000) \\ &= 255,089 \text{ kJ (Lower than } 259,648 \text{ kJ)} \end{aligned}$$

By interpolation,

$$T_P = \mathbf{3045 \text{ K}}$$

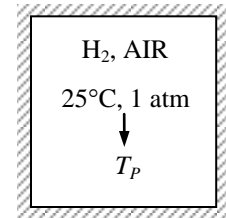

15-79 Methane is burned with 200 percent excess air adiabatically in a constant volume container. The final pressure and temperature of product gases are to be determined.

Assumptions 1 Air and combustion gases are ideal gases. **3** Kinetic and potential energies are negligible. **4** There are no work interactions. **5** The combustion chamber is adiabatic.

Analysis The combustion equation is

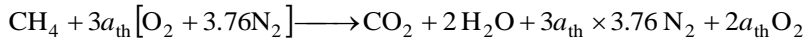

where a_{th} is the stoichiometric coefficient and is determined from the O_2 balance,

$$3a_{\text{th}} = 1 + 1 + 2a_{\text{th}} \longrightarrow a_{\text{th}} = 2$$

Substituting, $\text{CH}_4 + 6[\text{O}_2 + 3.76\text{N}_2] \longrightarrow \text{CO}_2 + 2\text{H}_2\text{O} + 22.56\text{N}_2 + 4\text{O}_2$

For this constant-volume process, the energy balance $E_{\text{in}} - E_{\text{out}} = \Delta E_{\text{system}}$ applied on the combustion chamber with $Q = W = 0$ reduces to

$$\sum N_P (\bar{h}_f^\circ + \bar{h} - \bar{h}^\circ - P\bar{v})_P = \sum N_R (\bar{h}_f^\circ + \bar{h} - \bar{h}^\circ - P\bar{v})_R$$

Since both the reactants and products are assumed to be ideal gases, all the internal energy and enthalpies depend on temperature only, and the $P\bar{v}$ terms in this equation can be replaced by $R_u T$. It yields

$$\sum N_P (\bar{h}_f^\circ + \bar{h} - \bar{h}^\circ - R_u T)_P = \sum N_R (\bar{h}_f^\circ + \bar{h} - \bar{h}^\circ - R_u T)_R$$

From the tables,

Substance	\bar{h}_f° kJ/kmol	$\bar{h}_{298\text{K}}$ kJ/kmol
$\text{CH}_4(g)$	-74,850	---
O_2	0	8682
N_2	0	8669
$\text{H}_2\text{O}(g)$	-241,820	9904
CO_2	-393,520	9364

Thus,

$$\begin{aligned} & (1)(-393,520 + \bar{h}_{\text{CO}_2} - 9364 - 8.314 \times T_p) + (2)(-241,820 + \bar{h}_{\text{H}_2\text{O}} - 9904 - 8.314 \times T_p) \\ & + (4)(0 + \bar{h}_{\text{O}_2} - 8682 - 8.314 \times T_p) + (22.56)(0 + \bar{h}_{\text{N}_2} - 8669 - 8.314 \times T_p) \\ & = (1)(-74,850 - 8.314 \times 298) + (6)(0 - 8.314 \times 298) + (22.56)(-8.314 \times 298) \end{aligned}$$

It yields $\bar{h}_{\text{CO}_2} + 2\bar{h}_{\text{H}_2\text{O}} + 4\bar{h}_{\text{O}_2} + 22.56\bar{h}_{\text{N}_2} - 245.8T_p = -148,087 + 1,136,633 = 988,546 \text{ kJ}$

The adiabatic flame temperature is obtained from a trial and error solution. A first guess may be obtained by assuming all the products are nitrogen and using nitrogen enthalpy in the above equation. That is,

$$29.56\bar{h}_{\text{N}_2} - 245.8T_p = 988,546 \text{ kJ}$$

An investigation of Table A-18 shows that this equation is satisfied at a temperature close to 1460 K but it will be somewhat under it because of the higher specific heat of H_2O .

At 1380 K: $(64,116) + (2)(52,434) + (4)(44,923) + (22.56)(42,915) - (245.8)(1380) = 977,634$
(Lower than 988,546 kJ)

At 1400 K: $(65,271) + (2)(53,351) + (4)(45,648) + (22.56)(43,605) - (245.8)(1400) = 994,174$
(Higher than 988,546 kJ)

By interpolation, $T_p = \mathbf{1393 \text{ K}}$

The volume of reactants when 1 kmol of fuel is burned is

$$\mathcal{V} = \mathcal{V}_{\text{fuel}} + \mathcal{V}_{\text{air}} = (N_{\text{fuel}} + N_{\text{air}}) \frac{R_u T}{P} = (1 + 28.56) \text{ kmol} \frac{(8.314 \text{ kJ/kmol} \cdot \text{K})(298 \text{ K})}{101.3 \text{ kPa}} = 723.0 \text{ m}^3$$

The final pressure is then

$$P = N_{\text{prod}} \frac{R_u T}{\mathcal{V}} = (29.56 \text{ kmol}) \frac{(8.314 \text{ kJ/kmol} \cdot \text{K})(1393 \text{ K})}{723.0 \text{ m}^3} = \mathbf{474 \text{ kPa}}$$

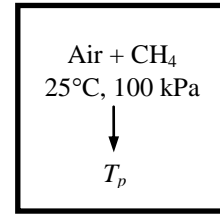

Entropy Change and Second Law Analysis of Reacting Systems

15-80C Assuming the system exchanges heat with the surroundings at T_0 , the increase-in-entropy principle can be expressed as

$$S_{\text{gen}} = \sum N_P \bar{s}_P - \sum N_R \bar{s}_R + \frac{Q_{\text{out}}}{T_0}$$

15-81C By subtracting $R \ln(P/P_0)$ from the tabulated value at 1 atm. Here P is the actual pressure of the substance and P_0 is the atmospheric pressure.

15-82C It represents the reversible work associated with the formation of that compound.

15-83 Liquid octane is burned steadily with 50 percent excess air. The heat transfer rate from the combustion chamber, the entropy generation rate, and the reversible work and exergy destruction rate are to be determined.

Assumptions 1 Combustion is complete. 2 Steady operating conditions exist. 3 Air and the combustion gases are ideal gases. 4 Changes in kinetic and potential energies are negligible.

Analysis (a) The fuel is burned completely with the excess air, and thus the products will contain only CO_2 , H_2O , N_2 , and some free O_2 . Considering 1 kmol C_8H_{18} , the combustion equation can be written as



where a_{th} is the stoichiometric coefficient and is determined from the O_2 balance,

$$1.5a_{\text{th}} = 8 + 4.5 + 0.5a_{\text{th}} \longrightarrow a_{\text{th}} = 12.5$$

Thus,

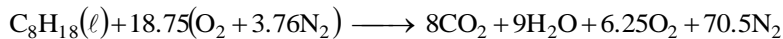

Under steady-flow conditions the energy balance $E_{\text{in}} - E_{\text{out}} = \Delta E_{\text{system}}$ applied on the combustion chamber with $W = 0$ reduces to

$$-Q_{\text{out}} = \sum N_P (\bar{h}_f^\circ + \bar{h} - \bar{h}^\circ)_P - \sum N_R (\bar{h}_f^\circ + \bar{h} - \bar{h}^\circ)_R = \sum N_P \bar{h}_{f,P}^\circ - \sum N_R \bar{h}_{f,R}^\circ$$

since all of the reactants are at 25°C . Assuming the air and the combustion products to be ideal gases, we have $h = h(T)$. From the tables,

Substance	\bar{h}_f° kJ/kmol
$\text{C}_8\text{H}_{18}(\ell)$	-249,950
O_2	0
N_2	0
$\text{H}_2\text{O}(l)$	-285,830
CO_2	-393,520

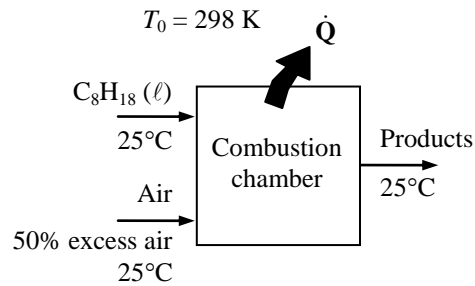

Substituting,

$$-Q_{\text{out}} = (8)(-393,520) + (9)(-285,830) + 0 + 0 - (1)(-249,950) - 0 - 0 = -5,470,680 \text{ kJ/kmol of } \text{C}_8\text{H}_{18} \text{ or}$$

or

$$Q_{\text{out}} = 5,470,680 \text{ kJ/kmol of } \text{C}_8\text{H}_{18}$$

The C_8H_{18} is burned at a rate of 0.25 kg/min or

$$\dot{N} = \frac{\dot{m}}{M} = \frac{0.25 \text{ kg/min}}{[(8)(12) + (18)(1)] \text{ kg/kmol}} = 2.193 \times 10^{-3} \text{ kmol/min}$$

Thus,

$$\dot{Q}_{\text{out}} = \dot{N} Q_{\text{out}} = (2.193 \times 10^{-3} \text{ kmol/min})(5,470,680 \text{ kJ/kmol}) = \mathbf{11,997 \text{ kJ/min}}$$

The heat transfer for this process is also equivalent to the enthalpy of combustion of liquid C_8H_{18} , which could easily be determined from Table A-27 to be $\bar{h}_c = 5,470,740 \text{ kJ/kmol } \text{C}_8\text{H}_{18}$.

(b) The entropy generation during this process is determined from

$$S_{\text{gen}} = S_P - S_R + \frac{Q_{\text{out}}}{T_{\text{surr}}} \longrightarrow S_{\text{gen}} = \sum N_P \bar{s}_P - \sum N_R \bar{s}_R + \frac{Q_{\text{out}}}{T_{\text{surr}}}$$

The C_8H_{18} is at $25^\circ C$ and 1 atm, and thus its absolute entropy is $\bar{s}_{C_8H_{18}} = 360.79 \text{ kJ/kmol}\cdot K$ (Table A-26). The entropy values listed in the ideal gas tables are for 1 atm pressure. Both the air and the product gases are at a total pressure of 1 atm, but the entropies are to be calculated at the partial pressure of the components which is equal to $P_i = y_i P_{\text{total}}$, where y_i is the mole fraction of component i . Also,

$$S_i = N_i \bar{s}_i(T, P_i) = N_i \left(\bar{s}_i^\circ(T, P_0) - R_u \ln(y_i P_m) \right)$$

The entropy calculations can be presented in tabular form as

	N_i	y_i	$\bar{s}_i^\circ(\mathbf{T}, \mathbf{1atm})$	$R_u \ln(y_i P_m)$	$N_i \bar{s}_i$
C_8H_{18}	1	1.00	360.79	---	360.79
O_2	18.75	0.21	205.14	-12.98	4089.75
N_2	70.50	0.79	191.61	-1.96	13646.69
$S_R = 18,097.23 \text{ kJ/K}$					
CO_2	8	0.0944	213.80	-19.62	1867.3
$H_2O (\ell)$	9	---	69.92	---	629.3
O_2	6.25	0.0737	205.04	-21.68	1417.6
N_2	70.50	0.8319	191.61	-1.53	13,616.3
$S_P = 17,531 \text{ kJ/K}$					

Thus,

$$S_{\text{gen}} = S_P - S_R + \frac{Q_{\text{surr}}}{T_{\text{surr}}} = 17,531 - 18,097 + \frac{5,470,523 \text{ kJ}}{298 \text{ K}} = 17,798 \text{ kJ/kmol}\cdot K$$

and

$$\dot{S}_{\text{gen}} = \dot{N} S_{\text{gen}} = (2.193 \times 10^{-3} \text{ kmol/min})(17,798 \text{ kJ/kmol}\cdot K) = \mathbf{39.03 \text{ kJ/min}\cdot K}$$

(c) The exergy destruction rate associated with this process is determined from

$$\dot{X}_{\text{destroyed}} = T_0 \dot{S}_{\text{gen}} = (298 \text{ K})(39.03 \text{ kJ/min}\cdot K) = 11,632 \text{ kJ/min} = \mathbf{193.9 \text{ kW}}$$

15-84E Benzene gas is burned steadily with 90 percent theoretical air. The heat transfer rate from the combustion chamber and the exergy destruction are to be determined.

Assumptions 1 Steady operating conditions exist. **2** Air and the combustion gases are ideal gases. **3** Changes in kinetic and potential energies are negligible.

Analysis (a) The fuel is burned with insufficient amount of air, and thus the products will contain some CO as well as CO₂, H₂O, and N₂. The theoretical combustion equation of C₆H₆ is

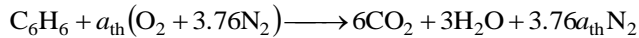

where a_{th} is the stoichiometric coefficient and is determined from the O₂ balance,

$$a_{\text{th}} = 6 + 1.5 = 7.5$$

Then the actual combustion equation can be written as

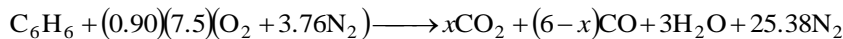

The value of x is determined from an O₂ balance,

$$(0.90)(7.5) = x + (6-x)/2 + 1.5 \longrightarrow x = 4.5$$

Thus,

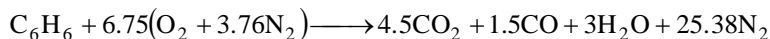

Under steady-flow conditions the energy balance $E_{\text{in}} - E_{\text{out}} = \Delta E_{\text{system}}$ applied on the combustion chamber with $W = 0$ reduces to

$$-Q_{\text{out}} = \sum N_P (\bar{h}_f^\circ + \bar{h} - \bar{h}^\circ)_P - \sum N_R (\bar{h}_f^\circ + \bar{h} - \bar{h}^\circ)_R = \sum N_P (\bar{h}_f^\circ + \bar{h} - \bar{h}^\circ)_P - \sum N_R \bar{h}_{f,R}^\circ$$

since all of the reactants are at 77°F. Assuming the air and the combustion products to be ideal gases, we have $h = h(T)$.

From the tables,

Substance	\bar{h}_f° Btu/lbmol	$\bar{h}_{537\text{ R}}$ Btu/lbmol	$\bar{h}_{1900\text{ R}}$ Btu/lbmol
C ₆ H ₆ (g)	35,680	---	---
O ₂	0	3725.1	14,322
N ₂	0	3729.5	13,742
H ₂ O (g)	-104,040	4258.0	16,428
CO	-47,540	3725.1	13,850
CO ₂	-169,300	4027.5	19,698

Thus,

$$\begin{aligned} -Q_{\text{out}} &= (4.5)(-169,300 + 19,698 - 4027.5) + (1.5)(-47,540 + 13,850 - 3725.1) \\ &\quad + (3)(-104,040 + 16,428 - 4258) + (25.38)(0 + 13,742 - 3729.5) - (1)(35,680) - 0 - 0 \\ &= \mathbf{-804,630 \text{ Btu/lbmol of C}_6\text{H}_6} \end{aligned}$$

(b) The entropy generation during this process is determined from

$$S_{\text{gen}} = S_P - S_R + \frac{Q_{\text{out}}}{T_{\text{surr}}} = \sum N_P \bar{s}_P - \sum N_R \bar{s}_R + \frac{Q_{\text{out}}}{T_{\text{surr}}}$$

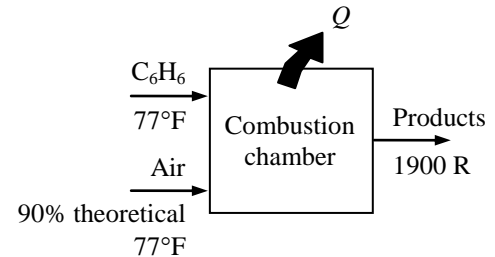

The C_6H_6 is at 77°F and 1 atm, and thus its absolute entropy is $\bar{s}_{C_6H_6} = 64.34$ Btu/lbmol·R (Table A-26E). The entropy values listed in the ideal gas tables are for 1 atm pressure. Both the air and the product gases are at a total pressure of 1 atm, but the entropies are to be calculated at the partial pressure of the components which is equal to $P_i = y_i P_{total}$, where y_i is the mole fraction of component i . Also,

$$S_i = N_i \bar{s}_i(T, P_i) = N_i (\bar{s}_i^\circ(T, P_0) - R_u \ln(y_i P_m))$$

The entropy calculations can be presented in tabular form as

	N_i	y_i	$\bar{s}_i^\circ(T, 1\text{atm})$	$R_u \ln(y_i P_m)$	$N_i \bar{s}_i$
C_6H_6	1	1.00	64.34	---	64.34
O_2	6.75	0.21	49.00	-3.10	351.68
N_2	25.38	0.79	45.77	-0.47	1173.57
					$S_R = 1589.59$ Btu/R
CO_2	4.5	0.1309	64.999	-4.038	310.67
CO	1.5	0.0436	56.509	-6.222	94.10
$H_2O(g)$	3	0.0873	56.097	-4.843	182.82
N_2	25.38	0.7382	54.896	-0.603	1408.56
					$S_P = 1996.15$ Btu/R

Thus,

$$S_{gen} = S_P - S_R + \frac{Q_{out}}{T_{sur}} = 1996.15 - 1589.59 + \frac{804,630}{537} = 1904.9 \text{ Btu/R}$$

Then the exergy destroyed is determined from

$$X_{destroyed} = T_0 S_{gen} = (537 \text{ R})(1904.9 \text{ Btu/lbmol} \cdot \text{R}) = \mathbf{1,022,950 \text{ Btu/R}} \text{ (per lbmol } C_6H_6 \text{)}$$



15-85 Liquid propane is burned steadily with 150 percent excess air. The mass flow rate of air, the heat transfer rate from the combustion chamber, and the rate of entropy generation are to be determined.

Assumptions 1 Combustion is complete. 2 Steady operating conditions exist. 3 Air and the combustion gases are ideal gases. 4 Changes in kinetic and potential energies are negligible.

Properties The molar masses of C_3H_8 and air are 44 kg/kmol and 29 kg/kmol, respectively (Table A-1).

Analysis (a) The fuel is burned completely with the excess air, and thus the products will contain only CO_2 , H_2O , N_2 , and some free O_2 . Considering 1 kmol of C_3H_8 , the combustion equation can be written as



where a_{th} is the stoichiometric coefficient and is determined from the O_2 balance,

$$2.5a_{th} = 3 + 2 + 1.5a_{th} \longrightarrow a_{th} = 5$$

Substituting,

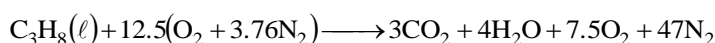

The air-fuel ratio for this combustion process is

$$AF = \frac{m_{air}}{m_{fuel}} = \frac{(12.5 \times 4.76 \text{ kmol})(29 \text{ kg/kmol})}{(3 \text{ kmol})(12 \text{ kg/kmol}) + (4 \text{ kmol})(2 \text{ kg/kmol})} = 39.2 \text{ kg air/kg fuel}$$

Thus,

$$\dot{m}_{air} = (AF)(\dot{m}_{fuel}) = (39.2 \text{ kg air/kg fuel})(0.4 \text{ kg fuel/min}) = \mathbf{15.7 \text{ kg air/min}}$$

(b) Under steady-flow conditions the energy balance $E_{in} - E_{out} = \Delta E_{system}$ applied on the combustion chamber with $W = 0$ reduces to

$$-Q_{out} = \sum N_P(\bar{h}_f^\circ + \bar{h} - \bar{h}^\circ)_P - \sum N_R(\bar{h}_f^\circ + \bar{h} - \bar{h}^\circ)_R$$

Assuming the air and the combustion products to be ideal gases, we have $h = h(T)$. From the tables, (The \bar{h}_f° of liquid propane is obtained by adding the h_{fg} at $25^\circ C$ to \bar{h}_f° of gaseous propane).

Substance	\bar{h}_f° kJ/kmol	$\bar{h}_{285 \text{ K}}$ kJ/kmol	$\bar{h}_{298 \text{ K}}$ kJ/kmol	$\bar{h}_{1200 \text{ K}}$ kJ/kmol
$C_3H_8(\ell)$	-118,910	---	---	---
O_2	0	8296.5	8682	38,447
N_2	0	8286.5	8669	36,777
$H_2O(g)$	-241,820	---	9904	44,380
CO_2	-393,520	---	9364	53,848

Thus,

$$\begin{aligned} -Q_{out} &= (3)(-393,520 + 53,848 - 9364) + (4)(-241,820 + 44,380 - 9904) \\ &\quad + (7.5)(0 + 38,447 - 8682) + (47)(0 + 36,777 - 8669) - (1)(-118,910 + h_{298} - h_{298}) \\ &\quad - (12.5)(0 + 8296.5 - 8682) - (47)(0 + 8286.5 - 8669) \\ &= -190,464 \text{ kJ/kmol of } C_3H_8 \end{aligned}$$

Thus 190,464 kJ of heat is transferred from the combustion chamber for each kmol (44 kg) of propane. This corresponds to $190,464/44 = 4328.7$ kJ of heat transfer per kg of propane. Then the rate of heat transfer for a mass flow rate of 0.4 kg/min for the propane becomes

$$\dot{Q}_{\text{out}} = \dot{m}q_{\text{out}} = (0.4 \text{ kg/min})(4328.7 \text{ kJ/kg}) = \mathbf{1732 \text{ kJ/min}}$$

(c) The entropy generation during this process is determined from

$$S_{\text{gen}} = S_P - S_R + \frac{Q_{\text{out}}}{T_{\text{surr}}} = \sum N_P \bar{s}_P - \sum N_R \bar{s}_R + \frac{Q_{\text{out}}}{T_{\text{surr}}}$$

The C_3H_8 is at 25°C and 1 atm, and thus its absolute entropy for the gas phase is $\bar{s}_{\text{C}_3\text{H}_8} = 269.91 \text{ kJ/kmol}\cdot\text{K}$ (Table A-26).

Then the entropy of $\text{C}_3\text{H}_8(\ell)$ is obtained from

$$s_{\text{C}_3\text{H}_8}(\ell) \cong s_{\text{C}_3\text{H}_8}(\text{g}) - s_{fg} = s_{\text{C}_3\text{H}_8}(\text{g}) - \frac{\bar{h}_{fg}}{T} = 269.91 - \frac{15,060}{298.15} = 219.4 \text{ kJ/kmol}\cdot\text{K}$$

The entropy values listed in the ideal gas tables are for 1 atm pressure. Both the air and the product gases are at a total pressure of 1 atm, but the entropies are to be calculated at the partial pressure of the components which is equal to $P_i = y_i P_{\text{total}}$, where y_i is the mole fraction of component i . Then,

$$S_i = N_i \bar{s}_i(T, P_i) = N_i \left(\bar{s}_i^\circ(T, P_0) - R_u \ln(y_i P_m) \right)$$

The entropy calculations can be presented in tabular form as

	N_i	y_i	$\bar{s}_i^\circ(\mathbf{T}, 1\text{atm})$	$R_u \ln(y_i P_m)$	$N_i \bar{s}_i$
C_3H_8	1	---	219.40	---	219.40
O_2	12.5	0.21	203.70	-12.98	2708.50
N_2	47	0.79	190.18	-1.96	9030.58
					$S_R = 11,958.48 \text{ kJ/K}$
CO_2	3	0.0488	279.307	-25.112	913.26
$\text{H}_2\text{O}(\text{g})$	4	0.0650	240.333	-22.720	1052.21
O_2	7.5	0.1220	249.906	-17.494	2005.50
N_2	47	0.7642	234.115	-2.236	11108.50
					$S_P = 15,079.47 \text{ kJ/K}$

Thus,

$$S_{\text{gen}} = S_P - S_R + \frac{Q_{\text{out}}}{T_{\text{surr}}} = 15,079.47 - 11,958.48 + \frac{190,464}{298} = 3760.1 \text{ kJ/K (per kmol } \text{C}_3\text{H}_8 \text{)}$$

Then the rate of entropy generation becomes

$$\dot{S}_{\text{gen}} = (\dot{N})(S_{\text{gen}}) = \left(\frac{0.4}{44} \text{ kmol/min} \right) (3760.1 \text{ kJ/kmol}\cdot\text{K}) = \mathbf{34.2 \text{ kJ/min}\cdot\text{K}}$$



15-86 Problem 15-85 is reconsidered. The effect of the surroundings temperature on the rate of exergy destruction is to be studied.

Analysis The problem is solved using EES, and the solution is given below.

```
Fuel$ = 'Propane (C3H8)_liq'
T_fuel = (25 + 273.15) "[K]"
P_fuel = 101.3 [kPa]
m_dot_fuel = 0.4 [kg/min]*Convert(kg/min, kg/s)
Ex = 1.5 "Excess air"
P_air = 101.3 [kPa]
T_air = (12+273.15) "[K]"
T_prod = 1200 [K]
P_prod = 101.3 [kPa]
Mw_air = 28.97 "lbm/lbmol_air"
Mw_C3H8=(3*12+8*1) "kg/kmol_C3H8"
{T_surrC = 25 [C]}
T_surr = T_surrC+273.15 "[K]"
```

"For theoretical dry air, the complete combustion equation is"
 $\text{C}_3\text{H}_8 + A_{\text{th}}(\text{O}_2 + 3.76 \text{N}_2) = 3 \text{CO}_2 + 4 \text{H}_2\text{O} + A_{\text{th}}(3.76) \text{N}_2$ "

$2 * A_{\text{th}} = 3 * 2 + 4 * 1$ "theoretical O balance"

"The balanced combustion equation with Ex%/100 excess moist air is"
 $\text{C}_3\text{H}_8 + (1 + \text{EX})A_{\text{th}}(\text{O}_2 + 3.76 \text{N}_2) = 3 \text{CO}_2 + 4 \text{H}_2\text{O} + (1 + \text{EX}) A_{\text{th}}(3.76) \text{N}_2 + \text{EX}(A_{\text{th}}) \text{O}_2$ "

"The air-fuel ratio on a mass basis is:"
 $\text{AF} = (1 + \text{EX}) * A_{\text{th}} * 4.76 * \text{Mw}_{\text{air}} / (1 * \text{Mw}_{\text{C}_3\text{H}_8})$ "kg_air/kg_fuel"

"The air mass flow rate is:"
 $m_{\text{dot_air}} = m_{\text{dot_fuel}} * \text{AF}$

"Apply First Law SSSF to the combustion process per kilomole of fuel:"
 $E_{\text{in}} - E_{\text{out}} = \text{DELTA}E_{\text{cv}}$
 $E_{\text{in}} = \text{HR}$

"Since EES gives the enthalpy of gaseous components, we adjust the EES calculated enthalpy to get the liquid enthalpy. Subtracting the enthalpy of vaporization from the gaseous enthalpy gives the enthalpy of the liquid fuel.

```
h_fuel(liq) = h_fuel(gas) - h_fg_fuel"
h_fg_fuel = 15060 "kJ/kmol from Table A-27"
HR = 1*(enthalpy(C3H8, T=T_fuel) - h_fg_fuel) + (1+Ex)*A_th*enthalpy(O2, T=T_air) + (1+Ex)*A_th*3.76
*enthalpy(N2, T=T_air)
E_out = HP + Q_out
HP = 3*enthalpy(CO2, T=T_prod) + 4*enthalpy(H2O, T=T_prod) + (1+Ex)*A_th*3.76*
enthalpy(N2, T=T_prod) + Ex*A_th*enthalpy(O2, T=T_prod)
DELTA E_cv = 0 "Steady-flow requirement"
```

"The heat transfer rate from the combustion chamber is:"
 $Q_{\text{dot_out}} = Q_{\text{out}} \text{ "kJ/kmol_fuel" } / (\text{Mw}_{\text{C}_3\text{H}_8} \text{ "kg/kmol_fuel" }) * m_{\text{dot_fuel}} \text{ "kg/s" } \text{ "kW"}$

"Entropy Generation due to the combustion process and heat rejection to the surroundings:"

"Entropy of the reactants per kilomole of fuel:"
 $P_{\text{O}_2\text{_reac}} = 1/4.76 * P_{\text{air}}$ "Dalton's law of partial pressures for O2 in air"
 $s_{\text{O}_2\text{_reac}} = \text{entropy}(\text{O}_2, T=T_{\text{air}}, P=P_{\text{O}_2\text{_reac}})$
 $P_{\text{N}_2\text{_reac}} = 3.76/4.76 * P_{\text{air}}$ "Dalton's law of partial pressures for N2 in air"
 $s_{\text{N}_2\text{_reac}} = \text{entropy}(\text{N}_2, T=T_{\text{air}}, P=P_{\text{N}_2\text{_reac}})$

$s_{C3H8_reac} = \text{entropy}(C3H8, T=T_{fuel}, P=P_{fuel}) - s_{fg_fuel}$ "Adjust the EES gaseous value by s_{fg} "
 "For phase change, s_{fg} is given by:"
 $s_{fg_fuel} = h_{fg_fuel}/T_{fuel}$
 $SR = 1*s_{C3H8_reac} + (1+Ex)*A_{th}*s_{O2_reac} + (1+Ex)*A_{th}*3.76*s_{N2_reac}$

"Entropy of the products per kilomole of fuel:"

"By Dalton's law the partial pressures of the product gases is the product of the mole fraction and P_{prod} "

$N_{prod} = 3 + 4 + (1+Ex)*A_{th}*3.76 + Ex*A_{th}$ "total kmol of products"

$P_{O2_prod} = Ex*A_{th}/N_{prod}*P_{prod}$ "Partial pressure O2 in products"

$s_{O2_prod} = \text{entropy}(O2, T=T_{prod}, P=P_{O2_prod})$

$P_{N2_prod} = (1+Ex)*A_{th}*3.76/N_{prod}*P_{prod}$ "Partial pressure N2 in products"

$s_{N2_prod} = \text{entropy}(N2, T=T_{prod}, P=P_{N2_prod})$

$P_{CO2_prod} = 3/N_{prod}*P_{prod}$ "Partial pressure CO2 in products"

$s_{CO2_prod} = \text{entropy}(CO2, T=T_{prod}, P=P_{CO2_prod})$

$P_{H2O_prod} = 4/N_{prod}*P_{prod}$ "Partial pressure H2O in products"

$s_{H2O_prod} = \text{entropy}(H2O, T=T_{prod}, P=P_{H2O_prod})$

$SP = 3*s_{CO2_prod} + 4*s_{H2O_prod} + (1+Ex)*A_{th}*3.76*s_{N2_prod} + Ex*A_{th}*s_{O2_prod}$

"Since Q_{out} is the heat rejected to the surroundings per kilomole fuel, the entropy of the surroundings is:"

$S_{surr} = Q_{out}/T_{surr}$

"Rate of entropy generation:"

$S_{dot_gen} = (SP - SR + S_{surr})$ "kJ/kmol_fuel"/(Mw_C3H8 "kg/kmol_fuel")*m_dot_fuel"kg/s" "kW/K"

$X_{dot_dest} = T_{surr}*S_{dot_gen}$ "kW"

TsurrC [C]	X _{dest} [kW]
0	157.8
4	159.7
8	161.6
12	163.5
16	165.4
20	167.3
24	169.2
28	171.1
32	173
36	174.9
38	175.8

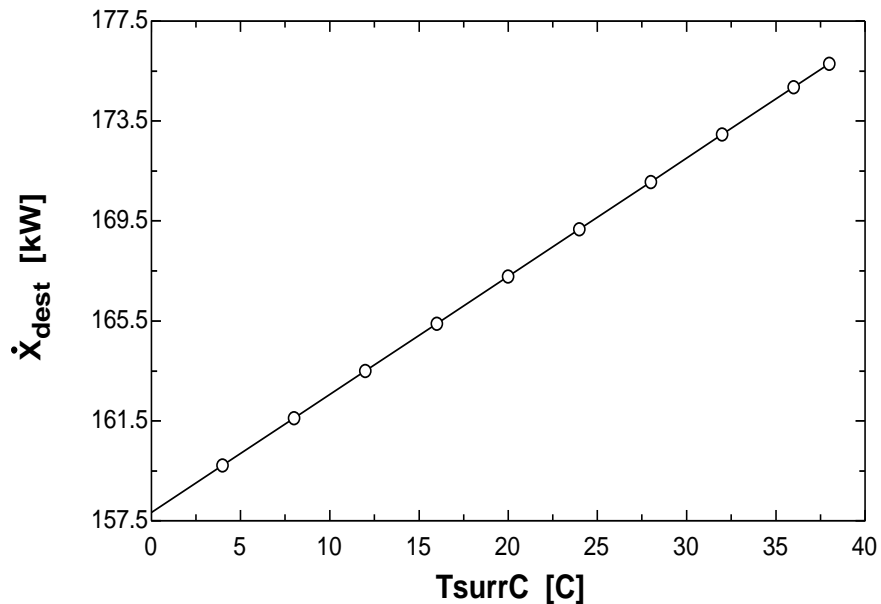

15-87 Liquid octane is burned steadily with 70 percent excess air. The entropy generation and exergy destruction per unit mass of the fuel are to be determined.

Assumptions 1 Combustion is complete. 2 Steady operating conditions exist. 3 Air and the combustion gases are ideal gases. 4 Changes in kinetic and potential energies are negligible.

Properties The molar masses of C_8H_{18} and air are 114 kg/kmol and 29 kg/kmol, respectively (Table A-1).

Analysis The fuel is burned completely with the excess air, and thus the products will contain only CO_2 , H_2O , N_2 , and some free O_2 . Considering 1 kmol C_8H_{18} , the combustion equation can be written as



where a_{th} is the stoichiometric coefficient and is determined from the O_2 balance,

$$1.7a_{th} = 8 + 4.5 + 0.7a_{th} \longrightarrow a_{th} = 12.5$$

Thus,

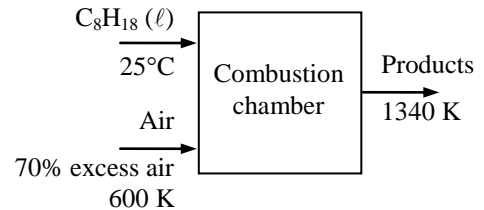
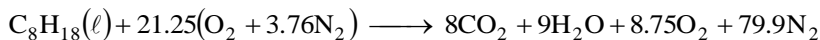

(b) Under steady-flow conditions the energy balance $E_{in} - E_{out} = \Delta E_{system}$ applied on the combustion chamber with $W = 0$ reduces to

$$-Q_{out} = \sum N_P (\bar{h}_f^\circ + \bar{h} - \bar{h}^\circ)_P - \sum N_R (\bar{h}_f^\circ + \bar{h} - \bar{h}^\circ)_R$$

Assuming the air and the combustion products to be ideal gases, we have $h = h(T)$. From the tables,

Substance	\bar{h}_f° kJ/kmol	\bar{h}_{298K} kJ/kmol	\bar{h}_{600K} kJ/kmol	\bar{h}_{1340K} kJ/kmol
$C_8H_{18}(\ell)$	-249,950	---	---	---
O_2	0	8682	17,929	43,475
N_2	0	8669	17,563	41,539
$H_2O(g)$	-241,820	9904	---	50,612
CO_2	-393,520	9364	---	61,813

Thus,

$$\begin{aligned} -Q_{out} &= (8)(-393,520 + 61,813 - 9364) + (9)(-241,820 + 50,612 - 9904) \\ &\quad + (8.75)(0 + 43,475 - 8682) + (79.9)(0 + 41,539 - 8669) - (1)(-249,950) \\ &\quad - (21.25)(0 + 17,929 - 8682) - (79.9)(0 + 17,563 - 8669) \\ &= -2,265,004 \text{ kJ/kmol of } C_8H_{18} \end{aligned}$$

The entropy generation during this process is determined from

$$S_{gen} = S_P - S_R + \frac{Q_{out}}{T_{surr}} = \sum N_P \bar{s}_P - \sum N_R \bar{s}_R + \frac{Q_{out}}{T_{surr}}$$

The entropy values listed in the ideal gas tables are for 1 atm pressure. Both the air and the product gases are at a total pressure of $P_m = 600 \text{ kPa}$ ($=600/101.325=5.92 \text{ atm}$), but the entropies are to be calculated at the partial pressure of the components which is equal to $P_i = y_i P_{total}$, where y_i is the mole fraction of component i . Then,

$$S_i = N_i \bar{s}_i(T, P_i) = N_i \left(\bar{s}_i^\circ(T, P_0) - R_u \ln(y_i P_m) \right)$$

The entropy calculations can be presented in tabular form as

	N_i	y_i	$\bar{s}_i^\circ(T, 1\text{atm})$	$R_u \ln(y_i P_m)$	$N_i \bar{s}_i$
C_8H_{18}	1	---	466.73	14.79	451.94
O_2	21.25	0.21	226.35	1.81	4771.48
N_2	79.9	0.79	212.07	12.83	15,919.28
					$S_R = 21,142.70 \text{ kJ/K}$
CO_2	8	0.0757	292.11	-6.673	2390.26
$H_2O(g)$	9	0.0852	250.45	-5.690	2305.26
O_2	8.75	0.0828	257.97	-5.928	2309.11
N_2	79.9	0.7563	241.77	12.46	18,321.87
					$S_P = 25,326.50 \text{ kJ/K}$

Thus,

$$S_{\text{gen}} = S_P - S_R + \frac{Q_{\text{out}}}{T_{\text{surr}}} = 25,326.50 - 21,142.70 + \frac{2,265,004}{298} = 11,784.5 \text{ kJ/K (per kmol } C_8H_{18}\text{)}$$

The exergy destruction is

$$X_{\text{dest}} = T_0 S_{\text{gen}} = (298)(11,784.5 \text{ kJ/K}) = 3,511,776 \text{ kJ/K (per kmol } C_8H_{18}\text{)}$$

The entropy generation and exergy destruction per unit mass of the fuel are

$$S_{\text{gen}} = \frac{\bar{S}_{\text{gen}}}{M_{\text{fuel}}} = \frac{11,784.5 \text{ kJ/K} \cdot \text{kmol}}{114 \text{ kg/kmol}} = \mathbf{103.4 \text{ kJ/K} \cdot \text{kg } C_8H_{18}}$$

$$X_{\text{dest}} = \frac{\bar{X}_{\text{dest}}}{M_{\text{fuel}}} = \frac{3,511,776 \text{ kJ/K} \cdot \text{kmol}}{114 \text{ kg/kmol}} = \mathbf{30,805 \text{ kJ/kg } C_8H_{18}}$$

15-88 Methyl alcohol is burned steadily with 200 percent excess air in an automobile engine. The maximum amount of work that can be produced by this engine is to be determined.

Assumptions 1 Combustion is complete. 2 Steady operating conditions exist. 3 Air and the combustion gases are ideal gases. 4 Changes in kinetic and potential energies are negligible.

Analysis The fuel is burned completely with the excess air, and thus the products will contain only CO_2 , H_2O , N_2 , and some free O_2 . Considering 1 kmol CH_3OH the combustion equation can be written as



where a_{th} is the stoichiometric coefficient and is determined from the O_2 balance,

$$0.5 + 3a_{\text{th}} = 1 + 1 + 2a_{\text{th}} \longrightarrow a_{\text{th}} = 1.5$$

Thus,

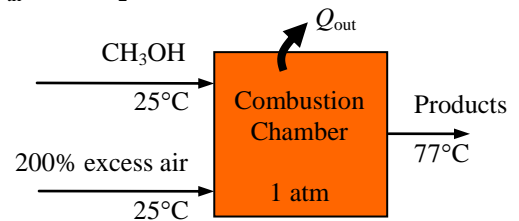
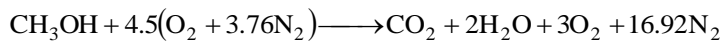

Under steady-flow conditions the energy balance $E_{\text{in}} - E_{\text{out}} = \Delta E_{\text{system}}$ applied on the combustion chamber with $W = 0$ reduces to

$$-Q_{\text{out}} = \sum N_P (\bar{h}_f^\circ + \bar{h} - \bar{h}^\circ)_P - \sum N_R (\bar{h}_f^\circ + \bar{h} - \bar{h}^\circ)_R$$

Assuming the air and the combustion products to be ideal gases, we have $h = h(T)$. From the tables,

Substance	\bar{h}_f° kJ/kmol	$\bar{h}_{298\text{K}}$ kJ/kmol	$\bar{h}_{350\text{K}}$ kJ/kmol
CH_3OH	-200,670	---	---
O_2	0	8682	10,213
N_2	0	8669	10,180
$\text{H}_2\text{O} (g)$	-241,820	9904	11,652
CO_2	-393,520	9364	11,351

Thus,

$$\begin{aligned} -Q_{\text{out}} &= (1)(-393,520 + 11,351 - 9364) + (2)(-241,820 + 11,652 - 9904) \\ &\quad + (3)(0 + 10,213 - 8682) + (16.92)(0 + 10,180 - 8669) - (1)(-200,670) \\ &= -663,550 \text{ kJ/kmol of fuel} \end{aligned}$$

The entropy generation during this process is determined from

$$S_{\text{gen}} = S_P - S_R + \frac{Q_{\text{out}}}{T_{\text{sur}}} = \sum N_P \bar{s}_P - \sum N_R \bar{s}_R + \frac{Q_{\text{out}}}{T_{\text{sur}}}$$

The entropy values listed in the ideal gas tables are for 1 atm pressure. Both the air and the product gases are at a total pressure of 1 atm, but the entropies are to be calculated at the partial pressure of the components which is equal to $P_i = y_i P_{\text{total}}$, where y_i is the mole fraction of component i . Then,

$$S_i = N_i \bar{s}_i(T, P_i) = N_i \left(\bar{s}_i^\circ(T, P_0) - R_u \ln(y_i P_m) \right)$$

The entropy calculations can be presented in tabular form as

	N_i	y_i	$\bar{s}_i^\circ(T, 1\text{atm})$	$R_u \ln(y_i P_m)$	$N_i \bar{s}_i$
CH ₃ OH	1	---	239.70	---	239.70
O ₂	4.5	0.21	205.04	-12.98	981.09
N ₂	16.92	0.79	191.61	-1.960	3275.20
					$S_R = 4496 \text{ kJ/K}$
CO ₂	1	0.0436	219.831	-26.05	245.88
H ₂ O (g)	2	0.0873	194.125	-20.27	428.79
O ₂	3	0.1309	209.765	-16.91	680.03
N ₂	16.92	0.7382	196.173	-2.52	3361.89
					$S_P = 4717 \text{ kJ/K}$

Thus,

$$S_{\text{gen}} = S_P - S_R + \frac{Q_{\text{out}}}{T_{\text{surr}}} = 4717 - 4496 + \frac{663,550}{298} = 2448 \text{ kJ/K (per kmol fuel)}$$

The maximum work is equal to the exergy destruction

$$W_{\text{max}} = X_{\text{dest}} = T_0 S_{\text{gen}} = (298)(2448 \text{ kJ/K}) = 729,400 \text{ kJ/K (per kmol fuel)}$$

Per unit mass basis,

$$W_{\text{max}} = \frac{729,400 \text{ kJ/K} \cdot \text{kmol}}{32 \text{ kg/kmol}} = \mathbf{22,794 \text{ kJ/kg fuel}}$$

15-89 CO gas is burned steadily with air. The heat transfer rate from the combustion chamber and the rate of exergy destruction are to be determined.

Assumptions 1 Combustion is complete. 2 Steady operating conditions exist. 3 Air and the combustion gases are ideal gases. 4 Changes in kinetic and potential energies are negligible.

Properties The molar masses of CO and air are 28 kg/kmol and 29 kg/kmol, respectively (Table A-1).

Analysis (a) We first need to calculate the amount of air used per kmol of CO before we can write the combustion equation,

$$\nu_{\text{CO}} = \frac{RT}{P} = \frac{(0.2968 \text{ kPa} \cdot \text{m}^3/\text{kg} \cdot \text{K})(310 \text{ K})}{110 \text{ kPa}} = 0.836 \text{ m}^3/\text{kg}$$

$$\dot{m}_{\text{CO}} = \frac{\dot{V}_{\text{CO}}}{\nu_{\text{CO}}} = \frac{0.4 \text{ m}^3/\text{min}}{0.836 \text{ m}^3/\text{kg}} = 0.478 \text{ kg/min}$$

Then the molar air-fuel ratio becomes

$$\overline{\text{AF}} = \frac{N_{\text{air}}}{N_{\text{fuel}}} = \frac{\dot{m}_{\text{air}} / M_{\text{air}}}{\dot{m}_{\text{fuel}} / M_{\text{fuel}}} = \frac{(1.5 \text{ kg/min}) / (29 \text{ kg/kmol})}{(0.478 \text{ kg/min}) / (28 \text{ kg/kmol})} = 3.03 \text{ kmol air/kmol fuel}$$

Thus the number of moles of O_2 used per mole of CO is $3.03/4.76 = 0.637$. Then the combustion equation in this case can be written as

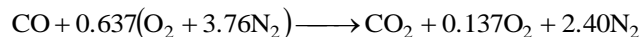

Under steady-flow conditions the energy balance $E_{\text{in}} - E_{\text{out}} = \Delta E_{\text{system}}$ applied on the combustion chamber with $W = 0$ reduces to

$$-Q_{\text{out}} = \sum N_P (\bar{h}_f^\circ + \bar{h} - \bar{h}^\circ)_P - \sum N_R (\bar{h}_f^\circ + \bar{h} - \bar{h}^\circ)_R$$

Assuming the air and the combustion products to be ideal gases, we have $h = h(T)$. From the tables,

Substance	\bar{h}_f° kJ/kmol	$\bar{h}_{298 \text{ K}}$ kJ/kmol	$\bar{h}_{310 \text{ K}}$ kJ/kmol	$\bar{h}_{900 \text{ K}}$ kJ/kmol
CO	-110,530	8669	9014	---
O_2	0	8682	---	27,928
N_2	0	8669	---	26,890
CO_2	-393,520	9364	---	37,405

Substituting,

$$\begin{aligned} -Q_{\text{out}} &= (1)(-393,520 + 37,405 - 9364) + (0.137)(0 + 27,928 - 8682) \\ &\quad + (2.4)(0 + 26,890 - 8669) - (1)(-110,530 + 9014 - 8669) - 0 - 0 \\ &= -208,929 \text{ kJ/kmol of CO} \end{aligned}$$

Thus 208,929 kJ of heat is transferred from the combustion chamber for each kmol (28 kg) of CO. This corresponds to $208,929/28 = 7462$ kJ of heat transfer per kg of CO. Then the rate of heat transfer for a mass flow rate of 0.478 kg/min for CO becomes

$$\dot{Q}_{\text{out}} = \dot{m}_{\text{CO}} (7462 \text{ kJ/kg}) = \mathbf{3567 \text{ kJ/min}}$$

(b) This process involves heat transfer with a reservoir other than the surroundings. An exergy balance on the combustion chamber in this case reduces to the following relation for reversible work,

$$W_{\text{rev}} = \sum N_R (\bar{h}_f^\circ + \bar{h} - \bar{h}^\circ - T_0 \bar{s})_R - \sum N_P (\bar{h}_f^\circ + \bar{h} - \bar{h}^\circ - T_0 \bar{s})_P - Q_{\text{out}} (1 - T_0 / T_R)$$

The entropy values listed in the ideal gas tables are for 1 atm = 101.325 kPa pressure. The entropy of each reactant and the product is to be calculated at the partial pressure of the components which is equal to $P_i = y_i P_{\text{total}}$, where y_i is the mole fraction of component i , and $P_m = 110/101.325 = 1.0856$ atm. Also,

PROPRIETARY MATERIAL. © 2015 McGraw-Hill Education. Limited distribution permitted only to teachers and educators for course preparation. If you are a student using this Manual, you are using it without permission.

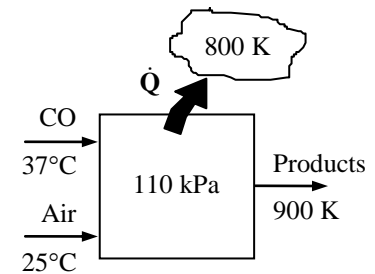

$$S_i = N_i \bar{s}_i(T, P_i) = N_i (\bar{s}_i^\circ(T, P_0) - R_u \ln(y_i P_m))$$

The entropy calculations can be presented in tabular form as

	N_i	y_i	$\bar{s}_i^\circ(\mathbf{T}, 1\text{atm})$	$R_u \ln(y_i P_m)$	$N_i \bar{s}_i$
CO	1	1.00	198.678	0.68	198.00
O ₂	0.637	0.21	205.04	-12.29	138.44
N ₂	2.400	0.79	191.61	-1.28	462.94
					$S_R = 799.38 \text{ kJ/K}$
CO ₂	1	0.2827	263.559	-9.821	273.38
O ₂	0.137	0.0387	239.823	-26.353	36.47
N ₂	2.400	0.6785	224.467	-2.543	544.82
					$S_P = 854.67 \text{ kJ/K}$

The rate of exergy destruction can be determined from

$$\dot{X}_{\text{destroyed}} = T_0 \dot{S}_{\text{gen}} = T_0 \dot{m} (S_{\text{gen}} / M)$$

where

$$S_{\text{gen}} = S_P - S_R + \frac{Q_{\text{out}}}{T_{\text{res}}} = 854.67 - 799.38 + \frac{208,929 \text{ kJ}}{800 \text{ K}} = 316.5 \text{ kJ/kmol} \cdot \text{K}$$

Thus,

$$\dot{X}_{\text{destroyed}} = (298 \text{ K})(0.478 \text{ kg/min})(316.5/28 \text{ kJ/kmol} \cdot \text{K}) = \mathbf{1610 \text{ kJ/min}}$$

15-90 Acetylene gas is burned steadily with 20 percent excess air. The temperature of the products, the total entropy change, and the exergy destruction are to be determined.

Assumptions 1 Combustion is complete. 2 Steady operating conditions exist. 3 Air and the combustion gases are ideal gases. 4 Changes in kinetic and potential energies are negligible.

Analysis (a) The fuel is burned completely with the excess air, and thus the products will contain only CO_2 , H_2O , N_2 , and some free O_2 . Considering 1 kmol C_2H_2 , the combustion equation can be written as



where a_{th} is the stoichiometric coefficient and is determined from the O_2 balance,

$$1.2a_{\text{th}} = 2 + 0.5 + 0.2a_{\text{th}} \longrightarrow a_{\text{th}} = 2.5$$

Substituting,

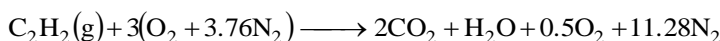

Under steady-flow conditions the exit temperature of the product gases can be determined from the energy balance $E_{\text{in}} - E_{\text{out}} = \Delta E_{\text{system}}$

applied on the combustion chamber, which reduces to

$$-Q_{\text{out}} = \sum N_P (\bar{h}_f^\circ + \bar{h} - \bar{h}^\circ)_P - \sum N_R \bar{h}_{f,R}^\circ = \sum N_P (\bar{h}_f^\circ + \bar{h} - \bar{h}^\circ)_P - (N\bar{h}_f^\circ)_{\text{C}_2\text{H}_2}$$

since all the reactants are at the standard reference state, and $\bar{h}_f^\circ = 0$ for O_2 and N_2 . From the tables,

Substance	\bar{h}_f° kJ/kmol	$\bar{h}_{298\text{ K}}$ kJ/kmol
$\text{C}_2\text{H}_2(g)$	226,730	---
O_2	0	8682
N_2	0	8669
$\text{H}_2\text{O}(g)$	-241,820	9904
CO_2	-393,520	9364

Substituting,

$$-300,000 = (2)(-393,520 + \bar{h}_{\text{CO}_2} - 9364) + (1)(-241,820 + \bar{h}_{\text{H}_2\text{O}} - 9904) + (0.5)(0 + \bar{h}_{\text{O}_2} - 8682) + (11.28)(0 + \bar{h}_{\text{N}_2} - 8669) - (1)(226,730)$$

or,

$$2\bar{h}_{\text{CO}_2} + \bar{h}_{\text{H}_2\text{O}} + 0.5\bar{h}_{\text{O}_2} + 11.28\bar{h}_{\text{N}_2} = 1,086,349 \text{ kJ}$$

By trial and error,

$$T_P = \mathbf{2062.1 \text{ K}}$$

(b) The entropy generation during this process is determined from

$$S_{\text{gen}} = S_P - S_R + \frac{Q_{\text{out}}}{T_{\text{surr}}} = \sum N_P \bar{s}_P - \sum N_R \bar{s}_R + \frac{Q_{\text{out}}}{T_{\text{surr}}}$$

The C_2H_2 is at 25°C and 1 atm, and thus its absolute entropy is $\bar{s}_{\text{C}_2\text{H}_2} = 200.85 \text{ kJ/kmol}\cdot\text{K}$ (Table A-26). The entropy values listed in the ideal gas tables are for 1 atm pressure. Both the air and the product gases are at a total pressure of 1 atm, but the entropies are to be calculated at the partial pressure of the components which is equal to $P_i = y_i P_{\text{total}}$, where y_i is the mole fraction of component i . Also,

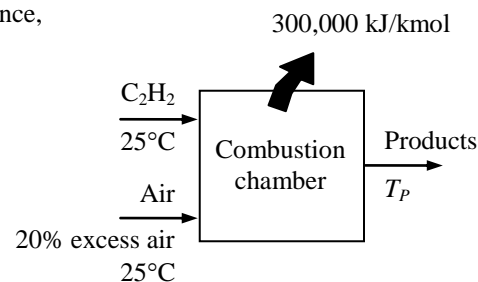

$$S_i = N_i \bar{s}_i(T, P_i) = N_i \left(\bar{s}_i^\circ(T, P_0) - R_u \ln(y_i P_m) \right)$$

The entropy calculations can be presented in tabular form as

	N_i	y_i	$\bar{s}_i^\circ(\mathbf{T}, 1\text{atm})$	$R_u \ln(y_i P_m)$	$N_i \bar{s}_i$
C_2H_2	1	1.00	200.85	---	200.85
O_2	3	0.21	205.03	-12.98	654.03
N_2	11.28	0.79	191.502	-1.96	2182.25
$S_R = 3037.13 \text{ kJ/K}$					
CO_2	2	0.1353	311.054	-16.630	655.37
H_2O	1	0.0677	266.139	-22.387	288.53
O_2	0.5	0.0338	269.810	-28.162	148.99
N_2	11.28	0.7632	253.068	-2.247	2879.95
$S_P = 3972.84 \text{ kJ/K}$					

Thus,

$$S_{\text{gen}} = S_P - S_R + \frac{Q_{\text{surr}}}{T_{\text{surr}}} = 3972.84 - 3037.13 + \frac{+300,000 \text{ kJ}}{298 \text{ K}} = \mathbf{1942.4 \text{ kJ/kmol} \cdot \mathbf{K}}$$

(c) The exergy destruction rate associated with this process is determined from

$$X_{\text{destruction}} = T_0 S_{\text{gen}} = (298 \text{ K})(1942.4 \text{ kJ/kmol} \cdot \text{K}) = \mathbf{578,835 \text{ kJ}} \text{ (per kmol } \text{C}_2\text{H}_2\text{)}$$

Review Problems

15-91 A sample of a certain fluid is burned in a bomb calorimeter. The heating value of the fuel is to be determined.

Properties The specific heat of water is $4.18 \text{ kJ/kg}\cdot^\circ\text{C}$ (Table A-3).

Analysis We take the water as the system, which is a closed system, for which the energy balance on the system

$E_{\text{in}} - E_{\text{out}} = \Delta E_{\text{system}}$ with $W = 0$ can be written as

$$Q_{\text{in}} = \Delta U$$

or

$$\begin{aligned} Q_{\text{in}} &= mc\Delta T \\ &= (2 \text{ kg})(4.18 \text{ kJ/kg}\cdot^\circ\text{C})(2.5^\circ\text{C}) \\ &= 20.90 \text{ kJ (per gram of fuel)} \end{aligned}$$

Therefore, heat transfer per kg of the fuel would be **20,900 kJ/kg fuel**. Disregarding the slight energy stored in the gases of the combustion chamber, this value corresponds to the heating value of the fuel.

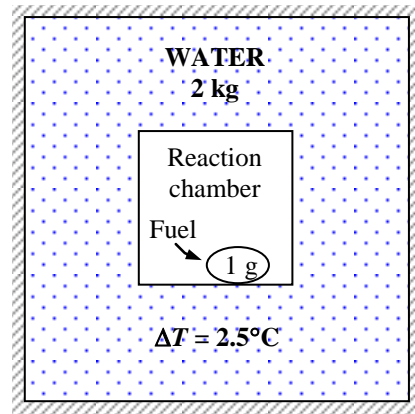

15-92 The composition of a gaseous fuel is given. The fuel is burned with 120 percent theoretical air. The AF ratio and the volume flow rate of air intake are to be determined.

Assumptions 1 Combustion is complete. **2** Air and the combustion gases are ideal gases.

Properties The molar masses of C, H₂, N₂, O₂, and air are 12, 2, 28, 32, and 29 kg/kmol (Table A-1).

Analysis (a) The fuel is burned completely with excess air, and thus the products will contain H₂O, CO₂, N₂, and some free O₂. The moisture in the air does not react with anything; it simply shows up as additional H₂O in the products. Therefore, we can simply balance the combustion equation using dry air, and then add the moisture to both sides of the equation. Considering 1 kmol of fuel, the combustion equation can be written as

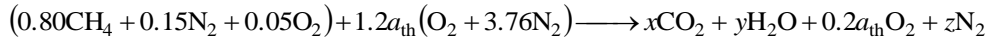

The unknown coefficients in the above equation are determined from mass balances,

$$\text{C: } 0.80 = x \longrightarrow x = 0.80$$

$$\text{H: } (0.80)(4) = 2y \longrightarrow y = 1.6$$

$$\text{O}_2: 0.05 + 1.2a_{\text{th}} = x + y/2 + 0.2a_{\text{th}} \longrightarrow a_{\text{th}} = 1.55$$

$$\text{N}_2: 0.15 + (1.2)(3.76)a_{\text{th}} = z \longrightarrow z = 7.14$$

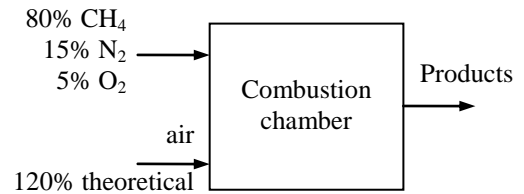

Next we determine the amount of moisture that accompanies $4.76 \times 1.2a_{\text{th}} = 4.76 \times 1.2 \times 1.55 = 8.85$ kmol of dry air. The partial pressure of the moisture in the air is

$$P_{v,\text{in}} = \phi_{\text{air}} P_{\text{sat}@30^\circ\text{C}} = (0.60)(4.247 \text{ kPa}) = 2.548 \text{ kPa}$$

The number of moles of the moisture in the air ($N_{v,\text{in}}$) is determined to be

$$N_{v,\text{in}} = \left(\frac{P_{v,\text{in}}}{P_{\text{total}}} \right) N_{\text{total}} = \left(\frac{2.548 \text{ kPa}}{100 \text{ kPa}} \right) (8.85 + N_{v,\text{in}}) \longrightarrow N_{v,\text{in}} = 0.23 \text{ kmol}$$

The balanced combustion equation is obtained by substituting the coefficients determined earlier and adding 0.23 kmol of H₂O to both sides of the equation,

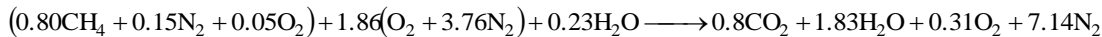

The air-fuel ratio for this reaction is determined by taking the ratio of the mass of the air to the mass of the fuel,

$$m_{\text{air}} = [(1.86)(4.76) \text{ kmol}](29 \text{ kg/kmol}) + (0.23 \text{ kg})(18 \text{ kg/kmol}) = 260.9 \text{ kg}$$

$$m_{\text{fuel}} = [(0.8)(16) + (0.15)(28) + (0.05)(32)] \text{ kg} = 18.6 \text{ kg}$$

and
$$\text{AF} = \frac{m_{\text{air}}}{m_{\text{fuel}}} = \frac{260.9 \text{ kg}}{18.6 \text{ kg}} = \mathbf{14.0 \text{ kg air/kg fuel}}$$

(b) The mass flow rate of the gaseous fuel is given to be 2 kg/min. Since we need 14.0 kg air per kg of fuel, the required mass flow rate of air is

$$\dot{m}_{\text{air}} = (\text{AF})(\dot{m}_{\text{fuel}}) = (14.0)(2 \text{ kg/min}) = 28.0 \text{ kg/min}$$

The mole fractions of water vapor and the dry air in the incoming air are

$$y_{\text{H}_2\text{O}} = \frac{N_{\text{H}_2\text{O}}}{N_{\text{total}}} = \frac{0.23}{8.85 + 0.23} = 0.025 \quad \text{and} \quad y_{\text{dry air}} = 1 - 0.025 = 0.975$$

Thus,

$$M = (yM)_{\text{H}_2\text{O}} + (yM)_{\text{dry air}} = (0.025)(18) + (0.975)(29) = 28.7 \text{ kg/kmol}$$

$$\nu = \frac{RT}{P} = \frac{(8.314/28.7 \text{ kPa} \cdot \text{m}^3/\text{kg} \cdot \text{K})(303 \text{ K})}{100 \text{ kPa}} = 0.878 \text{ m}^3/\text{kg}$$

$$\dot{V} = \dot{m} \nu = (28.0 \text{ kg/min})(0.878 \text{ m}^3/\text{kg}) = \mathbf{24.6 \text{ m}^3/\text{min}}$$

15-93E Hydrogen is burned with 100 percent excess air. The AF ratio and the volume flow rate of air are to be determined.

Assumptions 1 Combustion is complete. **2** Air and the combustion gases are ideal gases.

Properties The molar masses of H_2 and air are 2 kg/kmol and 29 kg/kmol, respectively (Table A-1).

Analysis (a) The combustion is complete, and thus products will contain only H_2O , O_2 and N_2 . The moisture in the air does not react with anything; it simply shows up as additional H_2O in the products. Therefore, for simplicity, we will balance the combustion equation using dry air, and then add the moisture to both sides of the equation. The combustion equation in this case can be written as

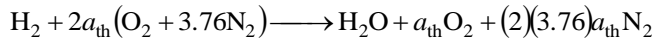

where a_{th} is the stoichiometric coefficient for air. It is determined from

$$O_2 \text{ balance: } 2a_{th} = 0.5 + a_{th} \longrightarrow a_{th} = 0.5$$

Substituting,

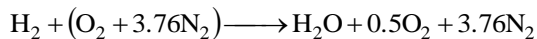

Therefore, 4.76 lbmol of dry air will be used per kmol of the fuel.

The partial pressure of the water vapor present in the incoming air is

$$P_{v,in} = \phi_{air} P_{sat@90^\circ F} = (0.60)(0.69904 \text{ psia}) = 0.419 \text{ psia}$$

The number of moles of the moisture that accompanies 4.76 lbmol of incoming dry air ($N_{v,in}$) is determined to be

$$N_{v,in} = \left(\frac{P_{v,in}}{P_{total}} \right) N_{total} = \left(\frac{0.419 \text{ psia}}{14.5 \text{ psia}} \right) (4.76 + N_{v,in}) \longrightarrow N_{v,in} = 0.142 \text{ lbmol}$$

The balanced combustion equation is obtained by substituting the coefficients determined earlier and adding 0.142 lbmol of H_2O to both sides of the equation,

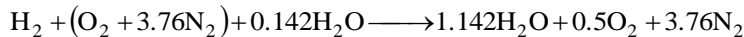

The air-fuel ratio is determined by taking the ratio of the mass of the air to the mass of the fuel,

$$AF = \frac{m_{air}}{m_{fuel}} = \frac{(4.76 \text{ lbmol})(29 \text{ lbm/lbmol}) + (0.142 \text{ lbmol})(18 \text{ lbm/lbmol})}{(1 \text{ lbmol})(2 \text{ lbm/lbmol})} = \mathbf{70.3 \text{ lbm air/lbm fuel}}$$

(b) The mass flow rate of H_2 is given to be 10 lbm/h. Since we need 70.3 lbm air per lbm of H_2 , the required mass flow rate of air is

$$\dot{m}_{air} = (AF)(\dot{m}_{fuel}) = (70.3)(40 \text{ lbm/h}) = 2812 \text{ lbm/h}$$

The mole fractions of water vapor and the dry air in the incoming air are

$$y_{H_2O} = \frac{N_{H_2O}}{N_{total}} = \frac{0.142}{4.76 + 0.142} = 0.029 \quad \text{and} \quad y_{dryair} = 1 - 0.029 = 0.971$$

Thus,

$$M = (yM)_{H_2O} + (yM)_{dryair} = (0.029)(18) + (0.971)(29) = 28.7 \text{ lbm/lbmol}$$

$$\nu = \frac{RT}{P} = \frac{(10.73/28.7 \text{ psia} \cdot \text{ft}^3/\text{lbm} \cdot \text{R})(540 \text{ R})}{14.5 \text{ psia}} = 13.92 \text{ ft}^3/\text{lbm}$$

$$\dot{V} = \dot{m} \nu = (2812 \text{ lbm/h})(13.92 \text{ ft}^3/\text{lbm}) = \mathbf{39,140 \text{ ft}^3/\text{h}}$$

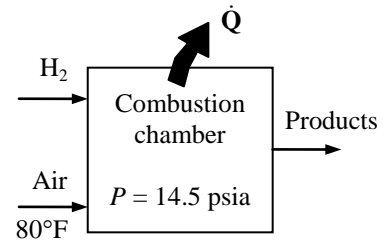

15-94E Propane is burned with stoichiometric amount of air. The fraction of the water in the products that is vapor is to be determined.

Assumptions **1** Combustion is complete. **2** Steady operating conditions exist. **3** Air and the combustion gases are ideal gases.

Analysis The fuel is burned completely with the air, and thus the products will contain only CO_2 , H_2O , and N_2 . Considering 1 kmol C_3H_8 , the combustion equation can be written as

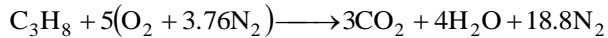

The mole fraction of water in the products is

$$y = \frac{N_{\text{H}_2\text{O}}}{N_{\text{prod}}} = \frac{4 \text{ kmol}}{(3 + 4 + 18.8)\text{kmol}} = 0.1550$$

The saturation pressure for the water vapor is

$$P_v = P_{\text{sat}@120^\circ\text{F}} = 1.6951 \text{ psia}$$

When the combustion gases are saturated, the mole fraction of the water vapor will be

$$y_g = \frac{P_v}{P} = \frac{1.6951 \text{ kPa}}{14.696 \text{ kPa}} = 0.1153$$

Thus, the fraction of water vapor in the combustion products is

$$f_{\text{vapor}} = \frac{y_g}{y} = \frac{0.1153}{0.1550} = \mathbf{0.744}$$

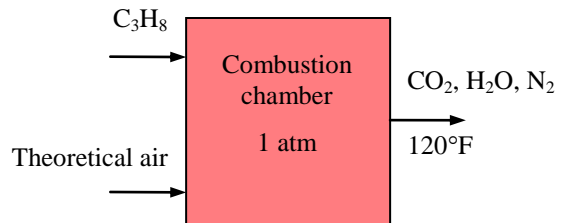

15-95 Coal whose mass percentages are specified is burned with 20% excess air. The dew-point temperature of the products is to be determined.

Assumptions 1 Combustion is complete. **2** The combustion products contain CO_2 , CO , H_2O , SO_2 , and N_2 . **3** Combustion gases are ideal gases.

Properties The molar masses of C, H_2 , O_2 , S, and air are 12, 2, 32, 32, and 29 kg/kmol, respectively (Table A-1).

Analysis We consider 100 kg of coal for simplicity. Noting that the mass percentages in this case correspond to the masses of the constituents, the mole numbers of the constituent of the coal are determined to be

$$N_{\text{C}} = \frac{m_{\text{C}}}{M_{\text{C}}} = \frac{61.40 \text{ kg}}{12 \text{ kg/kmol}} = 5.117 \text{ kmol}$$

$$N_{\text{H}_2} = \frac{m_{\text{H}_2}}{M_{\text{H}_2}} = \frac{5.79 \text{ kg}}{2 \text{ kg/kmol}} = 2.895 \text{ kmol}$$

$$N_{\text{O}_2} = \frac{m_{\text{O}_2}}{M_{\text{O}_2}} = \frac{25.31 \text{ kg}}{32 \text{ kg/kmol}} = 0.7909 \text{ kmol}$$

$$N_{\text{N}_2} = \frac{m_{\text{N}_2}}{M_{\text{N}_2}} = \frac{1.09 \text{ kg}}{28 \text{ kg/kmol}} = 0.03893 \text{ kmol}$$

$$N_{\text{S}} = \frac{m_{\text{S}}}{M_{\text{S}}} = \frac{1.41 \text{ kg}}{32 \text{ kg/kmol}} = 0.04406 \text{ kmol}$$

61.40% C
5.79% H_2
25.31% O_2
1.09% N_2
1.41% S
5.00% ash
(by mass)

The mole number of the mixture and the mole fractions are

$$N_m = 5.117 + 2.895 + 0.7909 + 0.03893 + 0.04406 = 8.886 \text{ kmol}$$

$$y_{\text{C}} = \frac{N_{\text{C}}}{N_m} = \frac{5.117 \text{ kmol}}{8.886 \text{ kmol}} = 0.5758$$

$$y_{\text{H}_2} = \frac{N_{\text{H}_2}}{N_m} = \frac{2.895 \text{ kmol}}{8.886 \text{ kmol}} = 0.3258$$

$$y_{\text{O}_2} = \frac{N_{\text{O}_2}}{N_m} = \frac{0.7909 \text{ kmol}}{8.886 \text{ kmol}} = 0.0890$$

$$y_{\text{N}_2} = \frac{N_{\text{N}_2}}{N_m} = \frac{0.03893 \text{ kmol}}{8.886 \text{ kmol}} = 0.00438$$

$$y_{\text{S}} = \frac{N_{\text{S}}}{N_m} = \frac{0.04406 \text{ kmol}}{8.886 \text{ kmol}} = 0.00496$$

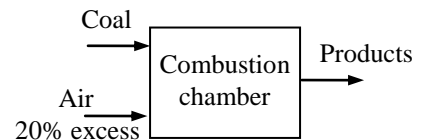

Ash consists of the non-combustible matter in coal. Therefore, the mass of ash content that enters the combustion chamber is equal to the mass content that leaves. Disregarding this non-reacting component for simplicity, the combustion equation may be written as

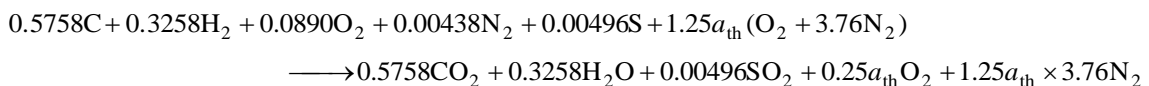

According to the oxygen balance,

$$\text{O}_2 \text{ balance : } 0.0890 + 1.25a_{\text{th}} = 0.5758 + 0.5 \times 0.3258 + 0.00496 + 0.25a_{\text{th}} \longrightarrow a_{\text{th}} = 0.6547$$

Substituting,

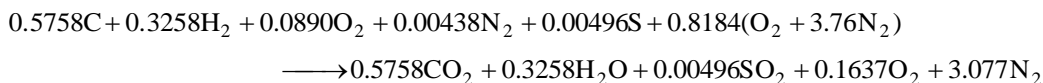

The dew-point temperature of a gas-vapor mixture is the saturation temperature of the water vapor in the product gases corresponding to its partial pressure. That is,

$$P_v = \left(\frac{N_v}{N_{\text{prod}}} \right) P_{\text{prod}} = \left(\frac{0.3258 \text{ kmol}}{(0.5758 + 0.3258 + 0.00496 + 0.1637 + 3.077) \text{ kmol}} \right) (101.3 \text{ kPa}) = 7.96 \text{ kPa}$$

Thus, $T_{\text{dp}} = T_{\text{sat}@7.96 \text{ kPa}} = \mathbf{41.3^\circ\text{C}}$ (Table A-5)

15-96 Methane is burned steadily with 15 percent excess air. The dew-point temperature of the water vapor in the products is to be determined.

Assumptions 1 Combustion is complete. 2 Steady operating conditions exist. 3 Air and the combustion gases are ideal gases.

Properties The molar masses of CH_4 and air are 16 kg/kmol and 29 kg/kmol, respectively (Table A-1).

Analysis The fuel is burned completely with the excess air, and thus the products will contain only CO_2 , H_2O , N_2 , and some free O_2 . Considering 1 kmol CH_4 , the combustion equation can be written as

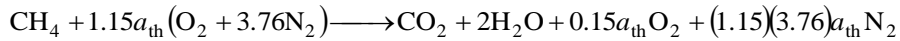

where a_{th} is the stoichiometric coefficient and is determined from the O_2 balance,

$$1.15a_{\text{th}} = 1 + 1 + 0.15a_{\text{th}} \longrightarrow a_{\text{th}} = 2$$

Thus,

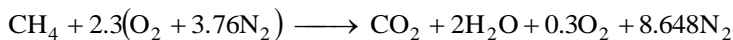

The dew-point temperature of a gas-vapor mixture is the saturation temperature of the water vapor in the product gases corresponding to its partial pressure. That is,

$$P_v = \left(\frac{N_v}{N_{\text{prod}}} \right) P_{\text{prod}} = \left(\frac{2 \text{ kmol}}{(1 + 2 + 0.3 + 8.648) \text{ kmol}} \right) (101.325 \text{ kPa}) = 16.96 \text{ kPa}$$

Thus,

$$T_{\text{dp}} = T_{\text{sat}@16.96 \text{ kPa}} = \mathbf{56.5^\circ\text{C}} \quad (\text{EES or Table A-5})$$

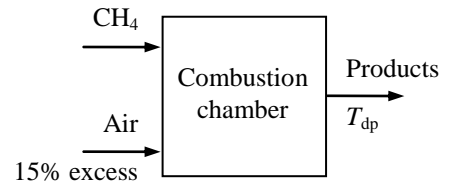

15-97 A mixture of 40% by volume methane, CH₄, and 60% by volume propane, C₃H₈, is burned completely with theoretical air. The amount of water formed during combustion process that will be condensed is to be determined.

Assumptions 1 Combustion is complete. **2** The combustion products contain CO₂, H₂O, and N₂ only.

Properties The molar masses of C, H₂, O₂ and air are 12 kg/kmol, 2 kg/kmol, 32 kg/kmol, and 29 kg/kmol, respectively (Table A-1).

Analysis The combustion equation in this case can be written as

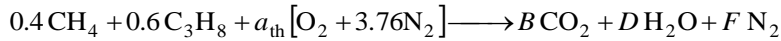

where a_{th} is the stoichiometric coefficient for air. The coefficient a_{th} and other coefficients are to be determined from the mass balances

Carbon balance: $B = 0.4 + 3 \times 0.6 = 2.2$

Hydrogen balance: $2D = 4 \times 0.4 + 8 \times 0.6 = 2D \longrightarrow D = 3.2$

Oxygen balance: $2a_{\text{th}} = 2B + D \longrightarrow 2a_{\text{th}} = 2(2.2) + 3.2 \longrightarrow a_{\text{th}} = 3.8$

Nitrogen balance: $3.76a_{\text{th}} = F \longrightarrow 3.76(3.8) = F \longrightarrow F = 14.29$

Then, we write the balanced reaction equation as

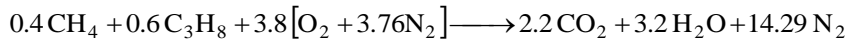

The vapor mole fraction in the products is

$$y_v = \frac{3.2}{2.2 + 3.2 + 14.29} = 0.1625$$

The partial pressure of water in the products is

$$P_{v,\text{prod}} = y_v P_{\text{prod}} = (0.1625)(100 \text{ kPa}) = 16.25 \text{ kPa}$$

The dew point temperature of the products is

$$T_{\text{dp}} = T_{\text{sat}@16.25\text{kPa}} = 55.64^\circ\text{C}$$

The partial pressure of the water vapor remaining in the products at the product temperature is

$$P_v = P_{\text{sat}@39^\circ\text{C}} = 7.0 \text{ kPa}$$

The kmol of water vapor in the products at the product temperature is

$$P_v = \frac{N_v}{N_{\text{total,product}}} P_{\text{prod}}$$

$$7.0 \text{ kPa} = \frac{N_v}{2.2 + N_v + 14.29} (100 \text{ kPa})$$

$$N_v = 1.241 \text{ kmol}$$

The kmol of water condensed is

$$N_w = 3.2 - 1.241 = \mathbf{1.96 \text{ kmol water/kmol fuel}}$$

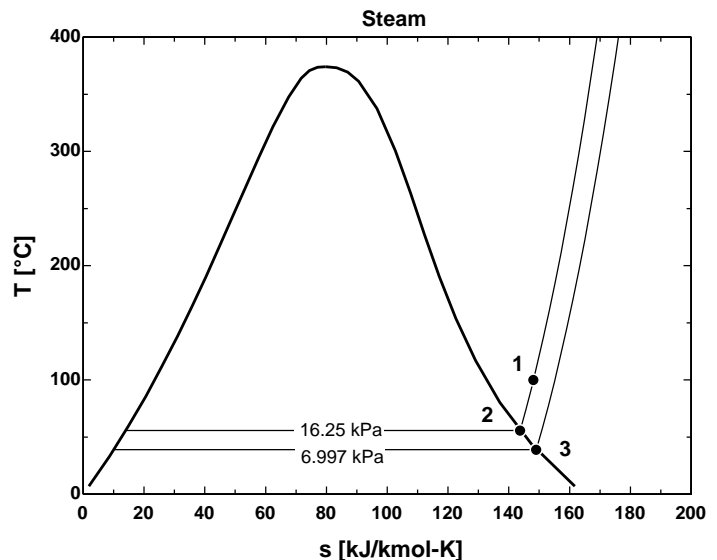
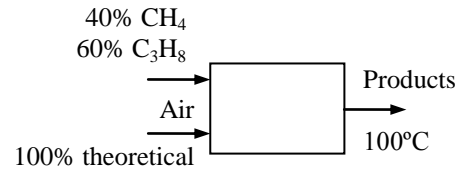

15-98 A gaseous fuel mixture of 60% propane, C_3H_8 , and 40% butane, C_4H_{10} , on a volume basis is burned with an air-fuel ratio of 19. The moles of nitrogen in the air supplied to the combustion process, the moles of water formed in the combustion process, and the moles of oxygen in the product gases are to be determined.

Assumptions 1 Combustion is complete. **2** The combustion products contain CO_2 , H_2O , and N_2 only.

Properties The molar masses of C, H_2 , O_2 and air are 12 kg/kmol, 2 kg/kmol, 32 kg/kmol, and 29 kg/kmol, respectively (Table A-1).

Analysis The theoretical combustion equation in this case can be written as

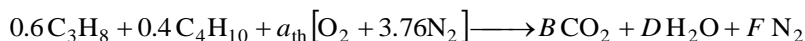

where a_{th} is the stoichiometric coefficient for air. The coefficient a_{th} and other coefficients are to be determined from the mass balances

$$\text{Carbon balance:} \quad B = 3 \times 0.6 + 4 \times 0.4 = 3.4$$

$$\text{Hydrogen balance:} \quad 8 \times 0.6 + 10 \times 0.4 = 2D \longrightarrow D = 4.4$$

$$\text{Oxygen balance:} \quad 2a_{th} = 2B + D \longrightarrow 2a_{th} = 2 \times 3.4 + 4.4 \longrightarrow a_{th} = 5.6$$

$$\text{Nitrogen balance:} \quad 3.76a_{th} = F \longrightarrow 3.76 \times 5.6 = F \longrightarrow F = 21.06$$

Then, we write the balanced theoretical reaction equation as

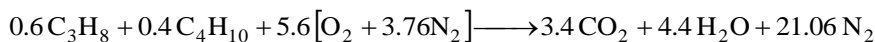

The air-fuel ratio for the theoretical reaction is determined from

$$AF_{th} = \frac{m_{air}}{m_{fuel}} = \frac{(5.6 \times 4.76 \text{ kmol})(29 \text{ kg/kmol})}{(0.6 \times 44 + 0.4 \times 58) \text{ kg}} = 15.59 \text{ kg air/kg fuel}$$

The percent theoretical air is

$$\text{PercentTH}_{air} = \frac{AF_{actual}}{AF_{th}} = \frac{19}{15.59} \times 100 = 121.9\%$$

The moles of nitrogen supplied is

$$N_{N_2} = \frac{\text{PercentTH}_{air}}{100} \times a_{th} \times 3.76 = \frac{121.9}{100} (5.6)(3.76) = \mathbf{25.7 \text{ kmol}} \text{ per kmol fuel}$$

The moles of water formed in the combustion process is

$$N_{H_2O} = D = \mathbf{4.4 \text{ kmol}} \text{ per kmol fuel}$$

The moles of oxygen in the product gases is

$$N_{O_2} = \left(\frac{\text{PercentTH}_{air}}{100} - 1 \right) a_{th} = \left(\frac{121.9}{100} - 1 \right) (5.6) = \mathbf{1.23 \text{ kmol}} \text{ per kmol fuel}$$

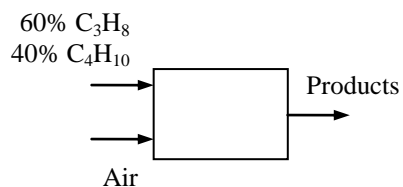

15-99 A liquid gas fuel mixture consisting of 90% octane, C_8H_{18} , and 10% alcohol, C_2H_5OH , by moles is burned with 200% theoretical dry air. The balanced reaction equation for complete combustion of this fuel mixture is to be written, and the theoretical air-fuel ratio and the product-fuel ratio for this reaction, and the lower heating value of the fuel mixture with 200% theoretical air are to be determined.

Assumptions 1 Combustion is complete. **2** The combustion products contain CO_2 , H_2O , O_2 , and N_2 only.

Properties The molar masses of C, H_2 , O_2 , N_2 , and air are 12, 2, 32, 28, and 29 kg/kmol, respectively (Table A-1).

Analysis The reaction equation for 100% excess air is

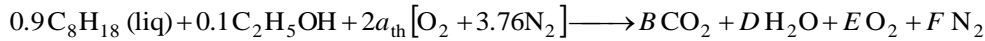

where a_{th} is the stoichiometric coefficient for air. We have automatically accounted for the 100% excess air by using the factor $2a_{\text{th}}$ instead of a_{th} for air. The coefficient a_{th} and other coefficients are to be determined from the mass balances

Carbon balance: $8 \times 0.9 + 2 \times 0.1 = B \longrightarrow B = 7.4$

Hydrogen balance: $18 \times 0.9 + 6 \times 0.1 = 2D \longrightarrow D = 8.4$

Oxygen balance: $0.1 \times 1 + 2 \times 2a_{\text{th}} = 2B + D + 2E$

$$a_{\text{th}} = E$$

Nitrogen balance: $2a_{\text{th}} \times 3.76 = F$

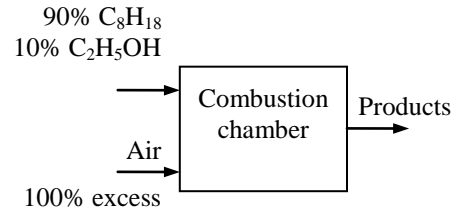

Solving the above equations, we find the coefficients ($E = 11.55$, $F = 86.86$, and $a_{\text{th}} = 11.55$) and write the balanced reaction equation as

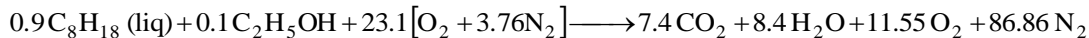

The theoretical air-fuel ratio is determined by taking the ratio of the mass of the air to the mass of the fuel for the theoretical reaction,

$$\begin{aligned} AF_{\text{th}} &= \frac{m_{\text{air}}}{m_{\text{fuel}}} = \frac{a_{\text{th}} \times 4.76 \times M_{\text{air}}}{0.9 \times M_{C_8H_{18}} + 0.1 \times M_{C_2H_5OH}} \\ &= \frac{(11.55 \times 4.76 \text{ kmol})(29 \text{ kg/kmol})}{(0.9 \times 114 + 0.1 \times 46) \text{ kg}} \\ &= \mathbf{14.83 \text{ kg air/kg fuel}} \end{aligned}$$

The actual air-fuel ratio is

$$AF_{\text{actual}} = 2AF_{\text{th}} = 2(14.83) = 29.65 \text{ kg air/kg fuel}$$

Then, the mass flow rate of air becomes

$$\dot{m}_{\text{air}} = AF_{\text{actual}} \dot{m}_{\text{fuel}} = (29.65)(5 \text{ kg/s}) = \mathbf{148.3 \text{ kg/s}}$$

The molar mass of the product gases is determined from

$$\begin{aligned} M_{\text{prod}} &= \frac{N_{CO_2}M_{CO_2} + N_{H_2O}M_{H_2O} + N_{O_2}M_{O_2} + N_{N_2}M_{N_2}}{N_{CO_2} + N_{H_2O} + N_{O_2} + N_{N_2}} \\ &= \frac{7.4(44) + 8.4(18) + 11.55(32) + 86.86(28)}{7.4 + 8.4 + 11.55 + 86.86} \\ &= 28.72 \text{ kg/kmol} \end{aligned}$$

The mass of product gases per unit mass of fuel is

$$\begin{aligned} m_{\text{prod}} &= \frac{(N_{CO_2} + N_{H_2O} + N_{O_2} + N_{N_2})M_{\text{prod}}}{0.9 \times M_{C_8H_{18}} + 0.1 \times M_{C_2H_5OH}} \\ &= \frac{(7.4 + 8.4 + 11.55 + 86.86)(28.72 \text{ kg/kmol})}{(0.9 \times 114 + 0.1 \times 46) \text{ kg}} \\ &= \mathbf{30.54 \text{ kg product/kg fuel}} \end{aligned}$$

The steady-flow energy balance can be expressed as

$$H_R = \bar{q}_{\text{LHV}} + H_P$$

where

$$\begin{aligned} H_R &= 0.9(\bar{h}_{\text{C}_8\text{H}_{18}@25^\circ\text{C}} - \bar{h}_{f_g,\text{C}_8\text{H}_{18}}) + 0.1(\bar{h}_{\text{C}_2\text{H}_5\text{OH}@25^\circ\text{C}} - \bar{h}_{f_g,\text{C}_2\text{H}_5\text{OH}}) + 23.1\bar{h}_{\text{O}_2@25^\circ\text{C}} + 86.86\bar{h}_{\text{N}_2@25^\circ\text{C}} \\ &= 0.9(-208,459 - 41,465) + 0.1(-235,310 - 42,340) + 23.1(0) + 86.86(0) \\ &= -252,697 \text{ kJ/kmol} \end{aligned}$$

$$\begin{aligned} H_P &= 7.4\bar{h}_{\text{CO}_2@25^\circ\text{C}} + 8.4\bar{h}_{\text{H}_2\text{O}@25^\circ\text{C}} + 11.55\bar{h}_{\text{N}_2@25^\circ\text{C}} + 86.86\bar{h}_{\text{N}_2@25^\circ\text{C}} \\ &= 7.4(-393,520) + 8.4(-241,820) + 11.55(0) + 86.86(0) \\ &= -4.943 \times 10^6 \text{ kJ/kmol} \end{aligned}$$

Substituting, we obtain

$$\bar{q}_{\text{LHV}} = 4.691 \times 10^6 \text{ kJ/kmol}$$

The lower heating value on a mass basis is determined to be

$$\begin{aligned} q_{\text{LHV}} &= \frac{\bar{q}_{\text{LHV}}}{0.9 \times M_{\text{C}_8\text{H}_{18}} + 0.1 \times M_{\text{C}_2\text{H}_5\text{OH}}} \\ &= \frac{4.691 \times 10^6 \text{ kJ/kmol}}{(0.9 \times 114 + 0.1 \times 46) \text{ kg/kmol}} \\ &= \mathbf{43,760 \text{ kJ/kg}} \end{aligned}$$

15-100 CO gas is burned with air during a steady-flow combustion process. The rate of heat transfer from the combustion chamber is to be determined.

Assumptions 1 Steady operating conditions exist. 2 Air and combustion gases are ideal gases. 3 Kinetic and potential energies are negligible. 4 There are no work interactions. 5 Combustion is complete.

Properties The molar masses of CO and air are 28 kg/kmol and 29 kg/kmol, respectively (Table A-1).

Analysis We first need to calculate the amount of air used per kmol of CO before we can write the combustion equation,

$$\nu_{\text{CO}} = \frac{RT}{P} = \frac{(0.2968 \text{ kPa} \cdot \text{m}^3/\text{kg} \cdot \text{K})(310 \text{ K})}{(110 \text{ kPa})} = 0.836 \text{ m}^3/\text{kg}$$

$$\dot{m}_{\text{CO}} = \frac{\dot{V}_{\text{CO}}}{\nu_{\text{CO}}} = \frac{0.4 \text{ m}^3/\text{min}}{0.836 \text{ m}^3/\text{kg}} = 0.478 \text{ kg/min}$$

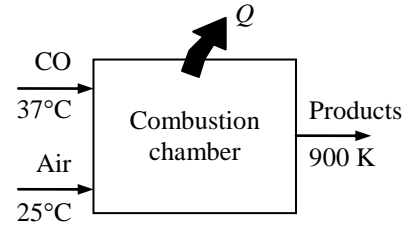

Then the molar air-fuel ratio becomes

$$\overline{\text{AF}} = \frac{N_{\text{air}}}{N_{\text{fuel}}} = \frac{\dot{m}_{\text{air}} / M_{\text{air}}}{\dot{m}_{\text{fuel}} / M_{\text{fuel}}} = \frac{(1.5 \text{ kg/min}) / (29 \text{ kg/kmol})}{(0.478 \text{ kg/min}) / (28 \text{ kg/kmol})} = 3.03 \text{ kmol air/kmol fuel}$$

Thus the number of moles of O_2 used per mole of CO is $3.03/4.76 = 0.637$. Then the combustion equation in this case can be written as

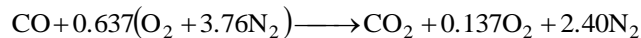

Under steady-flow conditions the energy balance $E_{\text{in}} - E_{\text{out}} = \Delta E_{\text{system}}$ applied on the combustion chamber with $W = 0$ reduces to

$$-Q_{\text{out}} = \sum N_P (\bar{h}_f^\circ + \bar{h} - \bar{h}^\circ)_P - \sum N_R (\bar{h}_f^\circ + \bar{h} - \bar{h}^\circ)_R$$

Assuming the air and the combustion products to be ideal gases, we have $h = h(T)$. From the tables,

Substance	\bar{h}_f° kJ/kmol	$\bar{h}_{298 \text{ K}}$ kJ/kmol	$\bar{h}_{310 \text{ K}}$ kJ/kmol	$\bar{h}_{900 \text{ K}}$ kJ/kmol
CO	-110,530	8669	9014	27,066
O_2	0	8682	---	27,928
N_2	0	8669	---	26,890
CO_2	-393,520	9364	---	37,405

Thus,

$$\begin{aligned} -Q_{\text{out}} &= (1)(-393,520 + 37,405 - 9364) + (0.137)(0 + 27,928 - 8682) \\ &\quad + (2.4)(0 + 26,890 - 8669) - (1)(-110,530 + 9014 - 8669) - 0 - 0 \\ &= -208,927 \text{ kJ/kmol of CO} \end{aligned}$$

Then the rate of heat transfer for a mass flow rate of 0.956 kg/min for CO becomes

$$\dot{Q}_{\text{out}} = \dot{N} Q_{\text{out}} = \left(\frac{\dot{m}}{M} \right) Q_{\text{out}} = \left(\frac{0.478 \text{ kg/min}}{28 \text{ kg/kmol}} \right) (208,927 \text{ kJ/kmol}) = \mathbf{3567 \text{ kJ/min}}$$

15-101 A mixture of hydrogen and the stoichiometric amount of air contained in a rigid tank is ignited. The fraction of H₂O that condenses and the heat transfer from the combustion chamber are to be determined.

Assumptions 1 Steady operating conditions exist. 2 Air and combustion gases are ideal gases. 3 Kinetic and potential energies are negligible. 4 There are no work interactions. 5 Combustion is complete.

Analysis The theoretical combustion equation of H₂ with stoichiometric amount of air is

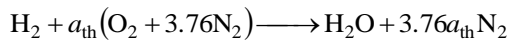

where a_{th} is the stoichiometric coefficient and is determined from the O₂ balance,

$$a_{\text{th}} = 0.5$$

Thus,

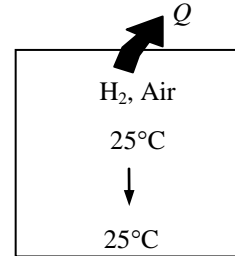
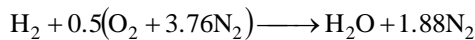

(a) At 25°C part of the water (say, N_w moles) will condense, and the number of moles of products that remains in the gas phase will be $2.88 - N_w$. Neglecting the volume occupied by the liquid water and treating all the product gases as ideal gases, the final pressure in the tank can be expressed as

$$P_f = \frac{N_{f,\text{gas}} R_u T_f}{V} = \frac{(2.88 - N_w \text{ kmol})(8.314 \text{ kPa} \cdot \text{m}^3/\text{kg} \cdot \text{K})(298 \text{ K})}{6 \text{ m}^3} = 412.9(2.88 - N_w) \text{ kPa}$$

Then,

$$\frac{N_v}{N_{\text{gas}}} = \frac{P_v}{P_{\text{total}}} \longrightarrow \frac{1 - N_w}{2.88 - N_w} = \frac{3.169 \text{ kPa}}{412.9(2.88 - N_w) \text{ kPa}} \longrightarrow N_w = 0.992 \text{ kmol}$$

Thus **99.2%** of the H₂O will condense when the products are cooled to 25°C.

(b) The energy balance $E_{\text{in}} - E_{\text{out}} = \Delta E_{\text{system}}$ applied for this constant volume combustion process with $W = 0$ reduces to

$$-Q_{\text{out}} = \sum N_P (\bar{h}_f^\circ + \bar{h} - \bar{h}^\circ - P\bar{v})_P - \sum N_R (\bar{h}_f^\circ + \bar{h} - \bar{h}^\circ - P\bar{v})_R$$

With the exception of liquid water for which the $P\bar{v}$ term is negligible, both the reactants and the products are assumed to be ideal gases, all the internal energy and enthalpies depend on temperature only, and the $P\bar{v}$ terms in this equation can be replaced by $R_u T$. It yields

$$\begin{aligned} -Q_{\text{out}} &= \sum N_P (\bar{h}_f^\circ - R_u T)_P - \sum N_R (\bar{h}_f^\circ - R_u T)_R \\ &= \sum N_P \bar{h}_{f,P}^\circ - \sum N_R \bar{h}_{f,R}^\circ - R_u T (\sum N_{P,\text{gas}} - \sum N_R) \end{aligned}$$

since the reactants are at the standard reference temperature of 25°C. From the tables,

Substance	\bar{h}_f° kJ/kmol
H ₂	0
O ₂	0
N ₂	0
H ₂ O (g)	-241,820
H ₂ O (ℓ)	-285,830

Thus,

$$\begin{aligned} -Q_{\text{out}} &= (0.008)(-241,820) + (0.992)(-285,830) + 0 - 0 - 0 - 0 - 8.314 \times 298(1.89 - 3.38) \\ &= -281,786 \text{ kJ (per kmol H}_2) \end{aligned}$$

or $Q_{\text{out}} = \mathbf{281,786 \text{ kJ}}$ (per kmol H₂)

15-102 Ethanol gas is burned with 10% excess air. The combustion is incomplete. The theoretical kmols of oxygen in the reactants, the balanced chemical reaction, and the rate of heat transfer are to be determined.

Assumptions 1 Combustion is incomplete. 2 The combustion products contain CO_2 , CO , H_2O , O_2 , and N_2 only.

Properties The molar masses of C, H_2 , O_2 , N_2 and air are 12 kg/kmol, 2 kg/kmol, 32 kg/kmol, 28 kg/kmol, and 29 kg/kmol, respectively (Table A-1).

Analysis (a) The balanced reaction equation for stoichiometric air is

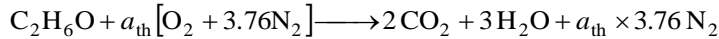

The stoichiometric coefficient a_{th} is determined from an O_2 balance:

$$0.5 + a_{\text{th}} = 2 + 1.5 \longrightarrow a_{\text{th}} = 3$$

Substituting,

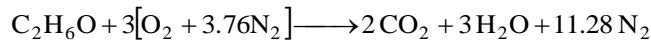

Therefore, **3 kmol of oxygen** is required to burn 1 kmol of ethanol.

(b) The reaction with 10% excess air and incomplete combustion can be written as

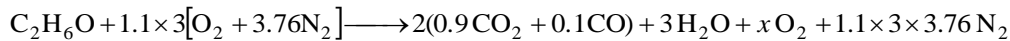

The coefficient for O_2 is determined from a mass balance,

$$\text{O}_2 \text{ balance: } 0.5 + 1.1 \times 3 = 0.9 \times 2 + 0.5 \times (0.1 \times 2) + 0.5 \times 3 + x \longrightarrow x = 0.4$$

Substituting,

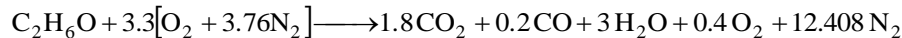

(b) The heat transfer for this combustion process is determined from the energy balance $E_{\text{in}} - E_{\text{out}} = \Delta E_{\text{system}}$ applied on the combustion chamber with $W = 0$. It reduces to

$$-Q_{\text{out}} = \sum N_P (\bar{h}_f^\circ + \bar{h} - \bar{h}^\circ)_P - \sum N_R (\bar{h}_f^\circ + \bar{h} - \bar{h}^\circ)_R$$

Both the reactants and products are at 25°C . Assuming the air and the combustion products to be ideal gases, we have $h = h(T)$. Then, using the values given in the table,

$$\begin{aligned} -Q_{\text{out}} &= (1.8)(-393,520) + (0.2)(-110,530) + (3)(-241,820) - (1)(-235,310) \\ &= -1,220,590 \text{ kJ/kmol fuel} \end{aligned}$$

or

$$Q_{\text{out}} = 1,220,590 \text{ kJ/kmol fuel}$$

For a 3.5 kg/h of fuel burned, the rate of heat transfer is

$$\dot{Q}_{\text{out}} = \dot{N} Q_{\text{out}} = \left(\frac{\dot{m}}{M} \right) Q_{\text{out}} = \frac{3.5 \text{ kg/h}}{46 \text{ kg/kmol}} (1,220,590 \text{ kJ/kmol}) = 92,870 \text{ kJ/h} = \mathbf{25.80 \text{ kW}}$$

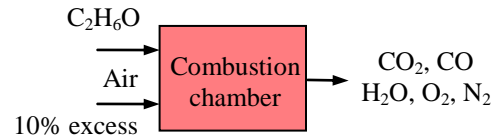

15-103 Propane gas is burned with air during a steady-flow combustion process. The adiabatic flame temperature is to be determined for different cases.

Assumptions 1 Steady operating conditions exist. **2** Air and combustion gases are ideal gases. **3** Kinetic and potential energies are negligible. **4** There are no work interactions. **5** The combustion chamber is adiabatic.

Analysis Adiabatic flame temperature is the temperature at which the products leave the combustion chamber under adiabatic conditions ($Q = 0$) with no work interactions ($W = 0$). Under steady-flow conditions the energy balance $E_{\text{in}} - E_{\text{out}} = \Delta E_{\text{system}}$ applied on the combustion chamber reduces to

$$\sum N_P (\bar{h}_f^\circ + \bar{h} - \bar{h}^\circ)_P = \sum N_R (\bar{h}_f^\circ + \bar{h} - \bar{h}^\circ)_R \longrightarrow \sum N_P (\bar{h}_f^\circ + \bar{h}_T - \bar{h}^\circ)_P = (N \bar{h}_f^\circ)_{\text{C}_3\text{H}_8}$$

since all the reactants are at the standard reference temperature of 25°C, and $\bar{h}_f^\circ = 0$ for O₂ and N₂.

(a) The theoretical combustion equation of C₃H₈ with stoichiometric amount of air is

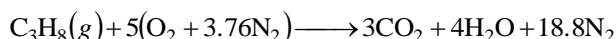

From the tables,

Substance	\bar{h}_f° kJ/kmol	$\bar{h}_{298\text{ K}}$ kJ/kmol
C ₃ H ₈ (g)	-103,850	---
O ₂	0	8682
N ₂	0	8669
H ₂ O (g)	-241,820	9904
CO	-110,530	8669
CO ₂	-393,520	9364

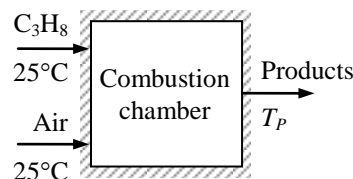

Thus,

$$(3)(-393,520 + \bar{h}_{\text{CO}_2} - 9364) + (4)(-241,820 + \bar{h}_{\text{H}_2\text{O}} - 9904) + (18.8)(0 + \bar{h}_{\text{N}_2} - 8669) = (1)(-103,850)$$

It yields

$$3\bar{h}_{\text{CO}_2} + 4\bar{h}_{\text{H}_2\text{O}} + 18.8\bar{h}_{\text{N}_2} = 2,274,675 \text{ kJ}$$

The adiabatic flame temperature is obtained from a trial and error solution. A first guess is obtained by dividing the right-hand side of the equation by the total number of moles, which yields $2,274,675 / (3 + 4 + 18.8) = 88,165$ kJ/kmol. This enthalpy value corresponds to about 2650 K for N₂. Noting that the majority of the moles are N₂, T_P will be close to 2650 K, but somewhat under it because of the higher specific heats of CO₂ and H₂O.

$$\begin{aligned} \text{At 2400 K: } 3\bar{h}_{\text{CO}_2} + 4\bar{h}_{\text{H}_2\text{O}} + 18.8\bar{h}_{\text{N}_2} &= (3)(125,152) + (4)(103,508) + (18.8)(79,320) \\ &= 2,280,704 \text{ kJ (Higher than 2,274,675 kJ)} \end{aligned}$$

$$\begin{aligned} \text{At 2350 K: } 3\bar{h}_{\text{CO}_2} + 4\bar{h}_{\text{H}_2\text{O}} + 18.8\bar{h}_{\text{N}_2} &= (3)(122,091) + (4)(100,846) + (18.8)(77,496) \\ &= 2,226,582 \text{ kJ (Lower than 2,274,675 kJ)} \end{aligned}$$

By interpolation, $T_P = \mathbf{2394 \text{ K}}$

(b) The balanced combustion equation for complete combustion with 200% theoretical air is

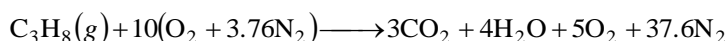

Substituting known numerical values,

$$(3)(-393,520 + \bar{h}_{\text{CO}_2} - 9364) + (4)(-241,820 + \bar{h}_{\text{H}_2\text{O}} - 9904) \\ + (5)(0 + \bar{h}_{\text{O}_2} - 8682) + (37.6)(0 + \bar{h}_{\text{N}_2} - 8669) = (1)(-103,850)$$

which yields

$$3\bar{h}_{\text{CO}_2} + 4\bar{h}_{\text{H}_2\text{O}} + 5\bar{h}_{\text{O}_2} + 37.6\bar{h}_{\text{N}_2} = 2,481,060 \text{ kJ}$$

The adiabatic flame temperature is obtained from a trial and error solution. A first guess is obtained by dividing the right-hand side of the equation by the total number of moles, which yields $2,481,060 / (3 + 4 + 5 + 37.6) = 50,021 \text{ kJ/kmol}$. This enthalpy value corresponds to about 1580 K for N_2 . Noting that the majority of the moles are N_2 , T_P will be close to 1580 K, but somewhat under it because of the higher specific heats of CO_2 and H_2O .

$$\text{At 1540 K: } 3\bar{h}_{\text{CO}_2} + 4\bar{h}_{\text{H}_2\text{O}} + 5\bar{h}_{\text{O}_2} + 37.6\bar{h}_{\text{N}_2} = (3)(73,417) + (4)(59,888) + (5)(50,756) + (37.6)(48,470) \\ = 2,536,055 \text{ kJ (Higher than 2,481,060 kJ)}$$

$$\text{At 1500 K: } 3\bar{h}_{\text{CO}_2} + 4\bar{h}_{\text{H}_2\text{O}} + 5\bar{h}_{\text{O}_2} + 37.6\bar{h}_{\text{N}_2} = (3)(71,078) + (4)(57,999) + (5)(49,292) + (37.6)(47,073) \\ = 2,461,630 \text{ kJ (Lower than 2,481,060 kJ)}$$

By interpolation, $T_P = \mathbf{1510 \text{ K}}$

(c) The balanced combustion equation for incomplete combustion with 90% theoretical air is

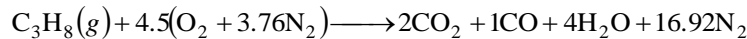

Substituting known numerical values,

$$(2)(-393,520 + \bar{h}_{\text{CO}_2} - 9364) + (1)(-110,530 + \bar{h}_{\text{CO}} - 8669) \\ + (4)(-241,820 + \bar{h}_{\text{H}_2\text{O}} - 9904) + (16.92)(0 + \bar{h}_{\text{N}_2} - 8669) = (1)(-103,850)$$

which yields

$$2\bar{h}_{\text{CO}_2} + \bar{h}_{\text{CO}} + 4\bar{h}_{\text{H}_2\text{O}} + 16.92\bar{h}_{\text{N}_2} = 1,974,692 \text{ kJ}$$

The adiabatic flame temperature is obtained from a trial and error solution. A first guess is obtained by dividing the right-hand side of the equation by the total number of moles, which yields $1,974,692 / (2 + 1 + 4 + 16.92) = 82,554 \text{ kJ/kmol}$. This enthalpy value corresponds to about 2500 K for N_2 . Noting that the majority of the moles are N_2 , T_P will be close to 2500 K, but somewhat under it because of the higher specific heats of CO_2 and H_2O .

At 2250 K:

$$2\bar{h}_{\text{CO}_2} + \bar{h}_{\text{CO}} + 4\bar{h}_{\text{H}_2\text{O}} + 16.92\bar{h}_{\text{N}_2} = (2)(115,984) + (1)(74,516) + (4)(95,562) + (16.92)(73,856) \\ = 1,938,376 \text{ kJ (Higher than 1,974,692 kJ)}$$

At 2300 K:

$$2\bar{h}_{\text{CO}_2} + \bar{h}_{\text{CO}} + 4\bar{h}_{\text{H}_2\text{O}} + 16.92\bar{h}_{\text{N}_2} = (2)(119,035) + (1)(76,345) + (4)(98,199) + (16.92)(75,676) \\ = 1,987,649 \text{ kJ (Lower than 1,974,692 kJ)}$$

By interpolation, $T_P = \mathbf{2287 \text{ K}}$

15-104 The highest possible temperatures that can be obtained when liquid gasoline is burned steadily with air and with pure oxygen are to be determined.

Assumptions 1 Steady operating conditions exist. **2** Air and combustion gases are ideal gases. **3** Kinetic and potential energies are negligible. **4** There are no work interactions. **5** The combustion chamber is adiabatic.

Analysis The highest possible temperature that can be achieved during a combustion process is the temperature which occurs when a fuel is burned completely with stoichiometric amount of air in an adiabatic combustion chamber. It is determined from

$$\sum N_P (\bar{h}_f^\circ + \bar{h} - \bar{h}^\circ)_P = \sum N_R (\bar{h}_f^\circ + \bar{h} - \bar{h}^\circ)_R \longrightarrow \sum N_P (\bar{h}_f^\circ + \bar{h}_T - \bar{h}^\circ)_P = (N\bar{h}_f^\circ)_{C_8H_{18}}$$

since all the reactants are at the standard reference temperature of 25°C, and for O₂ and N₂. The theoretical combustion equation of C₈H₁₈ air is

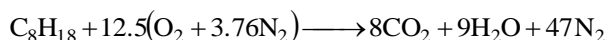

From the tables,

Substance	\bar{h}_f° kJ/kmol	$\bar{h}_{298\text{ K}}$ kJ/kmol
C ₈ H ₁₈ (ℓ)	-249,950	---
O ₂	0	8682
N ₂	0	8669
H ₂ O (g)	-241,820	9904
CO ₂	-393,520	9364

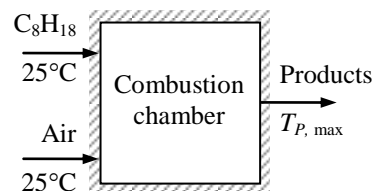

Thus,

$$(8)(-393,520 + \bar{h}_{CO_2} - 9364) + (9)(-241,820 + \bar{h}_{H_2O} - 9904) + (47)(0 + \bar{h}_{N_2} - 8669) = (1)(-249,950)$$

It yields $8\bar{h}_{CO_2} + 9\bar{h}_{H_2O} + 47\bar{h}_{N_2} = 5,646,081$ kJ

The adiabatic flame temperature is obtained from a trial and error solution. A first guess is obtained by dividing the right-hand side of the equation by the total number of moles, which yields $5,646,081/(8 + 9 + 47) = 88,220$ kJ/kmol. This enthalpy value corresponds to about 2650 K for N₂. Noting that the majority of the moles are N₂, T_P will be close to 2650 K, but somewhat under it because of the higher specific heat of H₂O.

$$\begin{aligned} \text{At 2400 K: } 8\bar{h}_{CO_2} + 9\bar{h}_{H_2O} + 47\bar{h}_{N_2} &= (8)(125,152) + (9)(103,508) + (47)(79,320) \\ &= 5,660,828 \text{ kJ (Higher than 5,646,081 kJ)} \end{aligned}$$

$$\begin{aligned} \text{At 2350 K: } 8\bar{h}_{CO_2} + 9\bar{h}_{H_2O} + 47\bar{h}_{N_2} &= (8)(122,091) + (9)(100,846) + (47)(77,496) \\ &= 5,526,654 \text{ kJ (Lower than 5,646,081 kJ)} \end{aligned}$$

By interpolation, $T_P = 2395$ K

If the fuel is burned with stoichiometric amount of pure O₂, the combustion equation would be

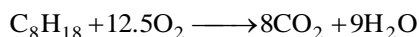

$$\text{Thus, } (8)(-393,520 + \bar{h}_{CO_2} - 9364) + (9)(-241,820 + \bar{h}_{H_2O} - 9904) = (1)(-249,950)$$

It yields $8\bar{h}_{CO_2} + 9\bar{h}_{H_2O} = 5,238,638$ kJ

The adiabatic flame temperature is obtained from a trial and error solution. A first guess is obtained by dividing the right-hand side of the equation by the total number of moles, which yields $5,238,638/(8 + 9) = 308,155$ kJ/kmol. This enthalpy value is higher than the highest enthalpy value listed for H₂O and CO₂. Thus an estimate of the adiabatic flame temperature can be obtained by extrapolation.

$$\text{At 3200 K: } 8\bar{h}_{CO_2} + 9\bar{h}_{H_2O} = (8)(174,695) + (9)(147,457) = 2,724,673 \text{ kJ}$$

$$\text{At 3250 K: } 8\bar{h}_{CO_2} + 9\bar{h}_{H_2O} = (8)(177,822) + (9)(150,272) = 2,775,024 \text{ kJ}$$

By extrapolation, we get $T_P = 3597$ K. However, the solution of this problem using EES gives **5645 K**. The large difference between these two values is due to extrapolation.

15-105 Liquid propane, C_3H_8 (liq) is burned with 150 percent excess air. The balanced combustion equation is to be written and the mass flow rate of air, the average molar mass of the product gases, the average specific heat of the product gases at constant pressure are to be determined.

Assumptions 1 Combustion is complete. **2** The combustion products contain CO_2 , H_2O , O_2 , and N_2 only.

Properties The molar masses of C, H_2 , O_2 , N_2 , and air are 12, 2, 32, 28, and 29 kg/kmol, respectively (Table A-1).

Analysis The reaction equation for 150% excess air is

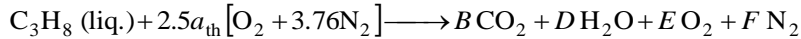

where a_{th} is the stoichiometric coefficient for air. We have automatically accounted for the 150% excess air by using the factor $2.5a_{th}$ instead of a_{th} for air. The coefficient a_{th} and other coefficients are to be determined from the mass balances

$$\text{Carbon balance:} \quad B = 3$$

$$\text{Hydrogen balance:} \quad 2D = 8 \longrightarrow D = 4$$

$$\text{Oxygen balance:} \quad 2 \times 2.5a_{th} = 2B + D + 2E$$

$$1.5a_{th} = E$$

$$\text{Nitrogen balance:} \quad 2.5a_{th} \times 3.76 = F$$

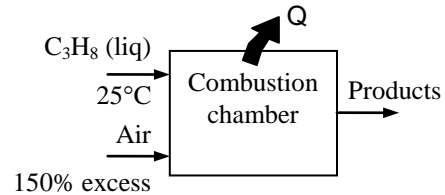

Solving the above equations, we find the coefficients ($E = 7.5$, $F = 47$, and $a_{th} = 5$) and write the balanced reaction equation as

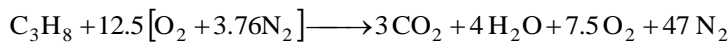

The fuel flow rate is

$$\dot{N}_{fuel} = \frac{\dot{m}_{fuel}}{M_{fuel}} = \frac{0.4 \text{ kg/min}}{44 \text{ kg/kmol}} = 0.009071 \text{ kmol/min}$$

The air-fuel ratio is determined by taking the ratio of the mass of the air to the mass of the fuel,

$$AF = \frac{m_{air}}{m_{fuel}} = \frac{(12.5 \times 4.76 \text{ kmol})(29 \text{ kg/kmol})}{(1 \text{ kmol})(44 \text{ kg/kmol})} = 39.08 \text{ kg air/kg fuel}$$

Then, the mass flow rate of air becomes

$$\dot{m}_{air} = AF\dot{m}_{fuel} = (39.08)(0.4 \text{ kg/min}) = \mathbf{15.63 \text{ kg/min}}$$

The molar mass of the product gases is determined from

$$\begin{aligned} M_{prod} &= \frac{N_{CO_2}M_{CO_2} + N_{H_2O}M_{H_2O} + N_{O_2}M_{O_2} + N_{N_2}M_{N_2}}{N_{CO_2} + N_{H_2O} + N_{O_2} + N_{N_2}} \\ &= \frac{3(44) + 4(18) + 7.5(32) + 47(28)}{3 + 4 + 7.5 + 47} \\ &= \mathbf{28.63 \text{ kg/kmol}} \end{aligned}$$

The steady-flow energy balance is expressed as

$$\dot{N}_{fuel}H_R = \dot{Q}_{out} + \dot{N}_{fuel}H_P$$

where

$$\begin{aligned} H_R &= \bar{h}_{fuel@25^\circ C}^o - \bar{h}_{fg} + 12.5\bar{h}_{O_2@25^\circ C} + 47\bar{h}_{N_2@25^\circ C} \\ &= (-103,847 \text{ kJ/kmol} - 40,525 \text{ kJ/kmol}) + 12.5(0) + 47(0) \\ &= -144,372 \text{ kJ/kmol} \end{aligned}$$

$$H_P = 3\bar{h}_{CO_2@T_p} + 4\bar{h}_{H_2O@T_p} + 7.5\bar{h}_{O_2@T_p} + 47\bar{h}_{N_2@T_p}$$

Substituting into the energy balance equation,

$$\dot{N}_{\text{fuel}}H_R = \dot{Q}_{\text{out}} + \dot{N}_{\text{fuel}}H_P$$

$$(0.009071 \text{ kmol/min})(-144,372 \text{ kJ/kmol}) = (53 \times 60) \text{ kJ/min} + (0.009071 \text{ kmol/min})H_P$$

$$H_P = -150,215 \text{ kJ/kmol}$$

Substituting this value into the H_P relation above and by a trial-error approach or using EES, we obtain the temperature of the products of combustion

$$T_P = \mathbf{1282K}$$

The average constant pressure specific heat of the combustion gases can be determined from

$$C_{p,\text{prod}} = \frac{N_{\text{CO}_2}C_{\text{CO}_2@1282\text{K}} + N_{\text{H}_2\text{O}}C_{\text{H}_2\text{O}@1282\text{K}} + N_{\text{O}_2}C_{\text{O}_2@1282\text{K}} + N_{\text{N}_2}C_{\text{N}_2@1282\text{K}}}{N_{\text{CO}_2} + N_{\text{H}_2\text{O}} + N_{\text{O}_2} + N_{\text{N}_2}}$$

$$= \frac{3(56.94) + 4(44.62) + 7.5(35.9) + 47(34.02)}{3 + 4 + 7.5 + 47}$$

$$= \mathbf{36.06 \text{ kJ/kmol}\cdot\text{K}}$$

where the specific heat values of the gases are determined from EES.

15-106E The work potential of diesel fuel at a given state is to be determined.

Assumptions 1 Steady operating conditions exist. 2 Air and combustion gases are ideal gases. 3 Kinetic and potential energies are negligible.

Analysis The work potential or availability of a fuel at a specified state is the reversible work that would be obtained if that fuel were burned completely with stoichiometric amount of air and the products are returned to the state of the surroundings. It is determined from

$$W_{\text{rev}} = \sum N_R (\bar{h}_f^\circ + \bar{h} + \bar{h}^\circ - T_0 \bar{s})_R - \sum N_P (\bar{h}_f^\circ + \bar{h} + \bar{h}^\circ - T_0 \bar{s})_P$$

or,
$$W_{\text{rev}} = \sum N_R (\bar{h}_f^\circ - T_0 \bar{s})_R - \sum N_P (\bar{h}_f^\circ - T_0 \bar{s})_P$$

since both the reactants and the products are at the state of the surroundings. Considering 1 kmol of $\text{C}_{12}\text{H}_{26}$, the theoretical combustion equation can be written as

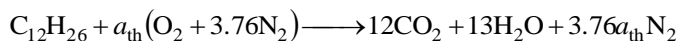

where a_{th} is the stoichiometric coefficient and is determined from the O_2 balance,

$$a_{\text{th}} = 12 + 6.5 \longrightarrow a_{\text{th}} = 18.5$$

Substituting,
$$\text{C}_{12}\text{H}_{26} + 18.5(\text{O}_2 + 3.76\text{N}_2) \longrightarrow 12\text{CO}_2 + 13\text{H}_2\text{O} + 69.56\text{N}_2$$

For each lbmol of fuel burned, $12 + 13 + 69.56 = 94.56$ lbmol of products are formed, including 13 lbmol of H_2O . Assuming that the dew-point temperature of the products is above 77°F , some of the water will exist in the liquid form in the products. If N_w lbmol of H_2O condenses, there will be $13 - N_w$ lbmol of water vapor left in the products. The mole number of the products in the gas phase will also decrease to $94.56 - N_w$ as a result. Treating the product gases (including the remaining water vapor) as ideal gases, N_w is determined by equating the mole fraction of the water vapor to pressure fraction,

$$\frac{N_v}{N_{\text{prod gas}}} = \frac{P_v}{P_{\text{prod}}} \longrightarrow \frac{13 - N_w}{94.56 - N_w} = \frac{0.4648 \text{ psia}}{14.7 \text{ psia}} \longrightarrow N_w = 10.34 \text{ lbmol}$$

since $P_v = P_{\text{sat}} @ 77^\circ\text{F} = 0.4648$ psia. Then the combustion equation can be written as

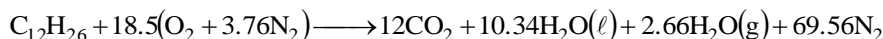

The entropy values listed in the ideal gas tables are for 1 atm pressure. Both the air and the product gases are at a total pressure of 1 atm, but the entropies are to be calculated at the partial pressure of the components which is equal to $P_i = y_i P_{\text{total}}$, where y_i is the mole fraction of component i . Also,

$$S_i = N_i \bar{s}_i(T, P_i) = N_i (\bar{s}_i^\circ(T, P_0) - R_u \ln(y_i P_m))$$

The entropy calculations can be presented in tabular form as

	N_i	y_i	$\bar{s}_i^\circ(77^\circ\text{F}, 1\text{atm})$	$R_u \ln(y_i P_m)$	\bar{s}_i	$h_f^\circ, \text{Btu/lbmol}$
$\text{C}_{12}\text{H}_{26}$	1	---	148.86	---	148.86	-125,190
O_2	18.5	0.21	49.00	-3.10	52.10	0
N_2	69.56	0.79	45.77	-0.47	46.24	0
CO_2	12	0.1425	51.07	-3.870	54.94	-169,300
$\text{H}_2\text{O}(\text{g})$	2.66	0.0316	45.11	-6.861	51.97	-104,040
$\text{H}_2\text{O}(\ell)$	10.34	---	16.71	---	16.71	-122,970
N_2	69.56	0.8259	45.77	-0.380	46.15	0

Substituting,

$$\begin{aligned} W_{\text{rev}} &= (1)(-125,190 - 537 \times 148.86) + (18.5)(0 - 537 \times 52.10) + (69.56)(0 - 537 \times 46.24) \\ &\quad - (12)(-169,300 - 537 \times 54.94) - (2.66)(-104,040 - 537 \times 51.97) \\ &\quad - (10.34)(-122,970 - 537 \times 16.71) - (69.56)(0 - 537 \times 46.15) \\ &= \mathbf{3,375,000 \text{ Btu}} \text{ (per lbmol } \text{C}_{12}\text{H}_{26}\text{)} \end{aligned}$$

15-107 n-Octane is burned with 30 percent excess air. The combustion is incomplete. The maximum work that can be produced is to be determined.

Assumptions 1 Combustion is incomplete. 2 Steady operating conditions exist. 3 Air and the combustion gases are ideal gases. 4 Changes in kinetic and potential energies are negligible.

Analysis The combustion equation with 30% excess air and 10% CO is

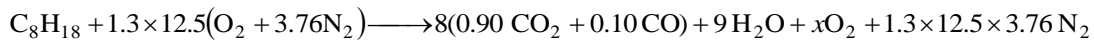

The coefficient for O_2 is determined from its mass balance as

$$1.3 \times 12.5 = 7.2 + 0.4 + 4.5 + x \longrightarrow x = 4.15$$

Substituting,



The reactants and products are at 25°C and 1 atm, which is the standard reference state and also the state of the surroundings. Therefore, the reversible work in this case is simply the difference between the Gibbs function of formation of the reactants and that of the products,

$$\begin{aligned} W_{\text{rev}} &= \sum N_R \bar{g}_{f,R}^\circ - \sum N_P \bar{g}_{f,P}^\circ \\ &= (1)(16,530) - (7.2)(-394,360) - (0.8)(-137,150) - (9)(-228,590) \\ &= 5,022,952 \text{ kJ (per kmol of fuel)} \end{aligned}$$

since the g_f° of stable elements at 25°C and 1 atm is zero. Per unit mass basis,

$$W_{\text{rev}} = \frac{5,022,952 \text{ kJ/kmol}}{114 \text{ kg/kmol}} = \mathbf{44,060 \text{ kJ/kg fuel}}$$

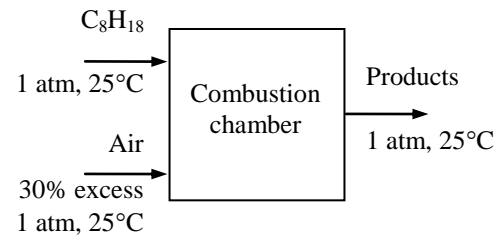

15-108 Methane is burned steadily with 50 percent excess air in a steam boiler. The amount of steam generated per unit of fuel mass burned, the change in the exergy of the combustion streams, the change in the exergy of the steam stream, and the lost work potential are to be determined.

Assumptions 1 Combustion is complete. **2** Steady operating conditions exist. **3** Air and the combustion gases are ideal gases. **4** Changes in kinetic and potential energies are negligible.

Properties The molar masses of CH₄ and air are 16 kg/kmol and 29 kg/kmol, respectively (Table A-1).

Analysis (a) The fuel is burned completely with the excess air, and thus the products will contain only CO₂, H₂O, N₂, and some free O₂. Considering 1 kmol CH₄, the combustion equation can be written as

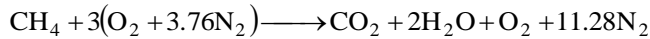

Under steady-flow conditions the energy balance $E_{\text{in}} - E_{\text{out}} = \Delta E_{\text{system}}$ applied on the combustion chamber with $W = 0$ reduces to

$$-Q_{\text{out}} = \sum N_P (\bar{h}_f^\circ + \bar{h} - \bar{h}^\circ)_P - \sum N_R (\bar{h}_f^\circ + \bar{h} - \bar{h}^\circ)_R$$

Assuming the air and the combustion products to be ideal gases, we have $h = h(T)$. From the tables,

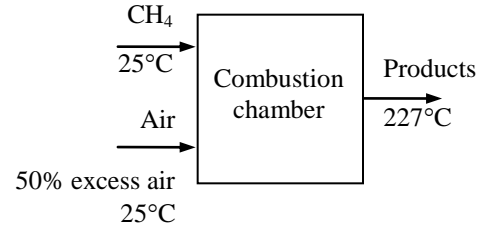

Substance	\bar{h}_f° kJ/kmol	$\bar{h}_{298\text{K}}$ kJ/kmol	$\bar{h}_{500\text{K}}$ kJ/kmol
CH ₄	-74,850	---	---
O ₂	0	8682	14,770
N ₂	0	8669	14,581
H ₂ O (g)	-241,820	9904	16,828
CO ₂	-393,520	9364	17,678

Thus,

$$\begin{aligned} -Q_{\text{out}} &= (1)(-393,520 + 17,678 - 9364) + (2)(-241,820 + 16,828 - 9904) \\ &\quad + (1)(0 + 14,770 - 8682) + (11.28)(0 + 14,581 - 8669) - (1)(-74,850) \\ &= -707,373 \text{ kJ/kmol of fuel} \end{aligned}$$

The heat loss per unit mass of the fuel is

$$Q_{\text{out}} = \frac{707,373 \text{ kJ/kmol of fuel}}{16 \text{ kg/kmol of fuel}} = 44,211 \text{ kJ/kg fuel}$$

The amount of steam generated per unit mass of fuel burned is determined from an energy balance to be (Enthalpies of steam are from tables A-4 and A-6)

$$\frac{m_s}{m_f} = \frac{Q_{\text{out}}}{\Delta h_s} = \frac{44,211 \text{ kJ/kg fuel}}{(3214.5 - 852.26) \text{ kJ/kg steam}} = \mathbf{18.72 \text{ kg steam/kg fuel}}$$

(b) The entropy generation during this process is determined from

$$S_{\text{gen}} = S_P - S_R + \frac{Q_{\text{out}}}{T_{\text{surr}}} = \sum N_P \bar{s}_P - \sum N_R \bar{s}_R + \frac{Q_{\text{out}}}{T_{\text{surr}}}$$

The entropy values listed in the ideal gas tables are for 1 atm pressure. Both the air and the product gases are at a total pressure of 1 atm, but the entropies are to be calculated at the partial pressure of the components which is equal to $P_i = y_i P_{\text{total}}$, where y_i is the mole fraction of component i . Then,

$$S_i = N_i \bar{s}_i(T, P_i) = N_i \left(\bar{s}_i^\circ(T, P_0) - R_u \ln(y_i P_m) \right)$$

The entropy calculations can be presented in tabular form as

	N_i	y_i	$\bar{s}_i^\circ(T, 1\text{atm})$	$R_u \ln(y_i P_m)$	$N_i \bar{s}_i$
CH ₄	1	---	186.16	0	186.16
O ₂	3	0.21	205.04	-12.98	654.06
N ₂	11.28	0.79	191.61	-1.960	2183.47
					$S_R = 3023.69 \text{ kJ/K}$
CO ₂	1	0.0654	234.814	-22.67	257.48
H ₂ O (g)	2	0.1309	206.413	-16.91	446.65
O ₂	1	0.0654	220.589	-22.67	243.26
N ₂	11.28	0.7382	206.630	-2.524	2359.26
					$S_P = 3306.65 \text{ kJ/K}$

Thus,

$$S_{\text{gen}} = S_P - S_R + \frac{Q_{\text{out}}}{T_{\text{surr}}} = 3306.65 - 3023.69 + \frac{707,373}{298} = 2657 \text{ kJ/K (per kmol fuel)}$$

The exergy change of the combustion streams is equal to the exergy destruction since there is no actual work output. That is,

$$\Delta X_{\text{gases}} = -X_{\text{dest}} = -T_0 S_{\text{gen}} = -(298 \text{ K})(2657 \text{ kJ/K}) = -791,786 \text{ kJ/kmol fuel}$$

Per unit mass basis,

$$\Delta X_{\text{gases}} = \frac{-791,786 \text{ kJ/kmol fuel}}{16 \text{ kg/kmol}} = \mathbf{-49,490 \text{ kJ/kg fuel}}$$

Note that the exergy change is negative since the exergy of combustion gases decreases.

(c) The exergy change of the steam stream is

$$\Delta X_{\text{steam}} = \Delta h - T_0 \Delta s = (3214.5 - 852.26) - (298)(6.7714 - 2.3305) = \mathbf{1039 \text{ kJ/kg steam}}$$

(d) The lost work potential is the negative of the net exergy change of both streams:

$$\begin{aligned} X_{\text{dest}} &= - \left(\frac{m_s}{m_f} \Delta X_{\text{steam}} + \Delta X_{\text{gases}} \right) \\ &= - [(18.72 \text{ kg steam/kg fuel})(1039 \text{ kJ/kg steam}) + (-49,490 \text{ kJ/kg fuel})] \\ &= \mathbf{30,040 \text{ kJ/kg fuel}} \end{aligned}$$

15-109 A coal from Utah is burned steadily with 50 percent excess air in a steam boiler. The amount of steam generated per unit of fuel mass burned, the change in the exergy of the combustion streams, the change in the exergy of the steam stream, and the lost work potential are to be determined.

Assumptions 1 Combustion is complete. 2 Steady operating conditions exist. 3 Air and the combustion gases are ideal gases. 4 Changes in kinetic and potential energies are negligible. 5 The effect of sulfur on the energy and entropy balances is negligible.

Properties The molar masses of C, H₂, N₂, O₂, S, and air are 12, 2, 28, 32, 32, and 29 kg/kmol, respectively (Table A-1).

Analysis (a) We consider 100 kg of coal for simplicity. Noting that the mass percentages in this case correspond to the masses of the constituents, the mole numbers of the constituent of the coal are determined to be

$$N_C = \frac{m_C}{M_C} = \frac{61.40 \text{ kg}}{12 \text{ kg/kmol}} = 5.117 \text{ kmol}$$

$$N_{H_2} = \frac{m_{H_2}}{M_{H_2}} = \frac{5.79 \text{ kg}}{2 \text{ kg/kmol}} = 2.895 \text{ kmol}$$

$$N_{O_2} = \frac{m_{O_2}}{M_{O_2}} = \frac{25.31 \text{ kg}}{32 \text{ kg/kmol}} = 0.7909 \text{ kmol}$$

$$N_{N_2} = \frac{m_{N_2}}{M_{N_2}} = \frac{1.09 \text{ kg}}{28 \text{ kg/kmol}} = 0.03893 \text{ kmol}$$

$$N_S = \frac{m_S}{M_S} = \frac{1.41 \text{ kg}}{32 \text{ kg/kmol}} = 0.04406 \text{ kmol}$$

61.40% C
5.79% H ₂
25.31% O ₂
1.09% N ₂
1.41% S
5.00% ash (by mass)

The mole number of the mixture and the mole fractions are

$$N_m = 5.117 + 2.895 + 0.7909 + 0.03893 + 0.04406 = 8.886 \text{ kmol}$$

$$y_C = \frac{N_C}{N_m} = \frac{5.117 \text{ kmol}}{8.886 \text{ kmol}} = 0.5758$$

$$y_{H_2} = \frac{N_{H_2}}{N_m} = \frac{2.895 \text{ kmol}}{8.886 \text{ kmol}} = 0.3258$$

$$y_{O_2} = \frac{N_{O_2}}{N_m} = \frac{0.7909 \text{ kmol}}{8.886 \text{ kmol}} = 0.0890$$

$$y_{N_2} = \frac{N_{N_2}}{N_m} = \frac{0.03893 \text{ kmol}}{8.886 \text{ kmol}} = 0.00438$$

$$y_S = \frac{N_S}{N_m} = \frac{0.04406 \text{ kmol}}{8.886 \text{ kmol}} = 0.00496$$

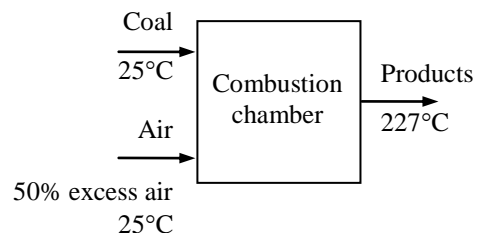

Ash consists of the non-combustible matter in coal. Therefore, the mass of ash content that enters the combustion chamber is equal to the mass content that leaves. Disregarding this non-reacting component for simplicity, the combustion equation may be written as

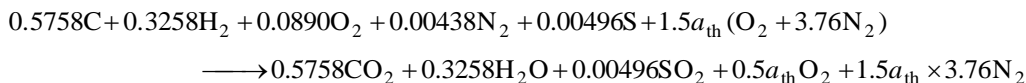

According to the oxygen balance,

$$O_2 \text{ balance: } 0.0890 + 1.5a_{th} = 0.5758 + 0.5 \times 0.3258 + 0.00496 + 0.5a_{th} \longrightarrow a_{th} = 0.6547$$

Substituting,

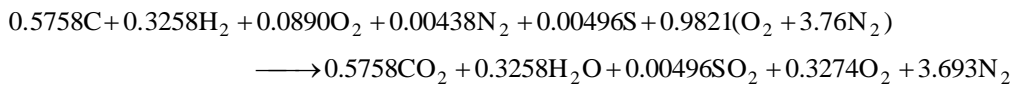

The apparent molecular weight of the coal is

$$\begin{aligned}
 M_m &= \frac{m_m}{N_m} \\
 &= \frac{(0.5758 \times 12 + 0.3258 \times 2 + 0.0890 \times 32 + 0.00438 \times 28 + 0.00496 \times 32) \text{ kg}}{(0.5758 + 0.3258 + 0.0890 + 0.00438 + 0.00496) \text{ kmol}} \\
 &= \frac{10.69 \text{ kg}}{1.0 \text{ kmol}} \\
 &= 10.69 \text{ kg/kmol coal}
 \end{aligned}$$

Under steady-flow conditions the energy balance $E_{\text{in}} - E_{\text{out}} = \Delta E_{\text{system}}$ applied on the combustion chamber with $W = 0$ reduces to

$$-Q_{\text{out}} = \sum N_P (\bar{h}_f^\circ + \bar{h} - \bar{h}^\circ)_P - \sum N_R (\bar{h}_f^\circ + \bar{h} - \bar{h}^\circ)_R$$

Assuming the air and the combustion products to be ideal gases, we have $h = h(T)$. From the tables,

Substance	\bar{h}_f° kJ/kmol	$\bar{h}_{298\text{K}}$ kJ/kmol	$\bar{h}_{500\text{K}}$ kJ/kmol
O ₂	0	8682	14,770
N ₂	0	8669	14,581
H ₂ O (g)	-241,820	9904	16,828
CO ₂	-393,520	9364	17,678

Thus,

$$\begin{aligned}
 -Q_{\text{out}} &= (0.5758)(-393,520 + 17,678 - 9364) + (0.3258)(-241,820 + 16,828 - 9904) \\
 &\quad + (0.3274)(0 + 14,770 - 8682) + (3.693)(0 + 14,581 - 8669) - 0 \\
 &= -274,505 \text{ kJ/kmol of fuel}
 \end{aligned}$$

The heat loss per unit mass of the fuel is

$$Q_{\text{out}} = \frac{274,505 \text{ kJ/kmol of fuel}}{10.69 \text{ kg/kmol of fuel}} = 25,679 \text{ kJ/kg fuel}$$

The amount of steam generated per unit mass of fuel burned is determined from an energy balance to be (Enthalpies of steam are from tables A-4 and A-6)

$$\frac{m_s}{m_f} = \frac{Q_{\text{out}}}{\Delta h_s} = \frac{25,679 \text{ kJ/kg fuel}}{(3214.5 - 852.26) \text{ kJ/kg steam}} = \mathbf{10.87 \text{ kg steam/kg fuel}}$$

(b) The entropy generation during this process is determined from

$$S_{\text{gen}} = S_P - S_R + \frac{Q_{\text{out}}}{T_{\text{surr}}} = \sum N_P \bar{s}_P - \sum N_R \bar{s}_R + \frac{Q_{\text{out}}}{T_{\text{surr}}}$$

The entropy values listed in the ideal gas tables are for 1 atm pressure. Both the air and the product gases are at a total pressure of 1 atm, but the entropies are to be calculated at the partial pressure of the components which is equal to $P_i = y_i P_{\text{total}}$, where y_i is the mole fraction of component i . Then,

$$S_i = N_i \bar{s}_i(T, P_i) = N_i (\bar{s}_i^\circ(T, P_0) - R_u \ln(y_i P_m))$$

The entropy calculations can be presented in tabular form as

	N_i	y_i	$\bar{s}_i^\circ(T, 1\text{atm})$	$R_u \ln(y_i P_m)$	$N_i \bar{s}_i$
C	0.5758	0.5758	5.74	-4.589	5.95
H ₂	0.3258	0.3258	130.68	-9.324	45.61
O ₂	0.0890	0.0890	205.04	-20.11	20.04
N ₂	0.00438	0.00438	191.61	-45.15	1.04
O ₂	0.9821	0.21	205.04	-12.98	214.12
N ₂	3.693	0.79	191.61	-1.960	714.85
					$S_R = 1001.61 \text{ kJ/K}$
CO ₂	0.5758	0.1170	234.814	-17.84	145.48
H ₂ O (g)	0.3258	0.0662	206.413	-22.57	74.60
O ₂	0.3274	0.0665	220.589	-22.54	79.60
N ₂	3.693	0.7503	206.630	-2.388	771.90
					$S_P = 1071.58 \text{ kJ/K}$

Thus,

$$S_{\text{gen}} = S_P - S_R + \frac{Q_{\text{out}}}{T_{\text{surr}}} = 1071.58 - 1001.61 + \frac{274,505}{298} = 991.1 \text{ kJ/K (per kmol fuel)}$$

The exergy change of the combustion streams is equal to the exergy destruction since there is no actual work output. That is,

$$\Delta X_{\text{gases}} = -X_{\text{dest}} = -T_0 S_{\text{gen}} = -(298 \text{ K})(991.1 \text{ kJ/K}) = -295,348 \text{ kJ/kmol fuel}$$

Per unit mass basis,

$$\Delta X_{\text{gases}} = \frac{-295,348 \text{ kJ/K}}{10.69 \text{ kg/kmol}} = \mathbf{-27,630 \text{ kJ/kg fuel}}$$

Note that the exergy change is negative since the exergy of combustion gases decreases.

(c) The exergy change of the steam stream is

$$\Delta X_{\text{steam}} = \Delta h - T_0 \Delta s = (3214.5 - 852.26) - (298)(6.7714 - 2.3305) = \mathbf{1039 \text{ kJ/kg steam}}$$

(d) The lost work potential is the negative of the net exergy change of both streams:

$$\begin{aligned} X_{\text{dest}} &= - \left(\frac{m_s}{m_f} \Delta X_{\text{steam}} + \Delta X_{\text{gases}} \right) \\ &= - \left[(10.87 \text{ kg steam/kg fuel})(1039 \text{ kJ/kg steam}) + (-27,630 \text{ kJ/kg fuel}) \right] \\ &= \mathbf{16,340 \text{ kJ/kg fuel}} \end{aligned}$$

15-110 Liquid octane is burned with 200 percent excess air during a steady-flow combustion process. The heat transfer rate from the combustion chamber, the power output of the turbine, and the reversible work and exergy destruction are to be determined.

Assumptions 1 Combustion is complete. 2 Steady operating conditions exist. 3 Air and the combustion gases are ideal gases. 4 Changes in kinetic and potential energies are negligible.

Properties The molar mass of C_8H_{18} is 114 kg/kmol (Table A-1).

Analysis (a) The fuel is burned completely with the excess air, and thus the products will contain only CO_2 , H_2O , N_2 , and some free O_2 . Considering 1 kmol of C_8H_{18} , the combustion equation can be written as



where a_{th} is the stoichiometric coefficient and is determined from the O_2 balance,

$$3a_{th} = 8 + 4.5 + 2a_{th} \longrightarrow a_{th} = 12.5$$

Substituting,

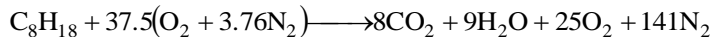

The heat transfer for this combustion process is determined from the energy balance $E_{in} - E_{out} = \Delta E_{system}$ applied on the combustion chamber with $W = 0$,

$$-Q_{out} = \sum N_P(\bar{h}_f^\circ + \bar{h} - \bar{h}^\circ)_P - \sum N_R(\bar{h}_f^\circ + \bar{h} - \bar{h}^\circ)_R$$

Assuming the air and the combustion products to be ideal gases, we have $h = h(T)$. From the tables,

Substance	\bar{h}_f° kJ/kmol	$\bar{h}_{500\text{ K}}$ kJ/kmol	$\bar{h}_{298\text{ K}}$ kJ/kmol	$\bar{h}_{1300\text{ K}}$ kJ/kmol	$\bar{h}_{950\text{ K}}$ kJ/kmol
$C_8H_{18}(\ell)$	-249,950	---	---	---	---
O_2	0	14,770	8682	42,033	26,652
N_2	0	14,581	8669	40,170	28,501
$H_2O(g)$	-241,820	---	9904	48,807	33,841
CO_2	-393,520	---	9364	59,552	40,070

Substituting,

$$\begin{aligned} -Q_{out} &= (8)(-393,520 + 59,522 - 9364) + (9)(-241,820 + 48,807 - 9904) \\ &\quad + (25)(0 + 42,033 - 8682) + (141)(0 + 40,170 - 8669) \\ &\quad - (1)(-249,950 + h_{298} - h_{298}) - (37.5)(0 + 14,770 - 8682) - (141)(0 + 14,581 - 8669) \\ &= -109,675 \text{ kJ/kmol } C_8H_{18} \end{aligned}$$

The C_8H_{18} is burned at a rate of 0.8 kg/min or

$$\dot{N} = \frac{\dot{m}}{M} = \frac{0.8 \text{ kg/min}}{((8)(12) + (18)(1)) \text{ kg/kmol}} = 7.018 \times 10^{-3} \text{ kmol/min}$$

Thus,

$$\dot{Q}_{out} = \dot{N}Q_{out} = (7.018 \times 10^{-3} \text{ kmol/min})(109,675 \text{ kJ/kmol}) = \mathbf{770 \text{ kJ/min}}$$

(b) Noting that no chemical reactions occur in the turbine, the turbine is adiabatic, and the product gases can be treated as ideal gases, the power output of the turbine can be determined from the steady-flow energy balance equation for nonreacting gas mixtures,

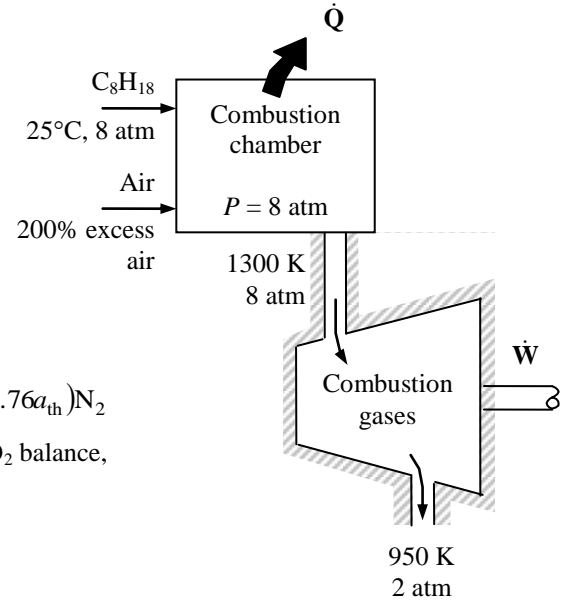

$$-W_{\text{out}} = \sum N_P (\bar{h}_e - \bar{h}_i) \longrightarrow W_{\text{out}} = \sum N_P (\bar{h}_{1300\text{K}} - \bar{h}_{950\text{K}})$$

Substituting,

$$W_{\text{out}} = (8)(59,522 - 40,070) + (9)(48,807 - 33,841) + (25)(42,033 - 29,652) + (141)(40,170 - 28,501) \\ = 2,245,164 \text{ kJ/kmol C}_8\text{H}_{18}$$

Thus the power output of the turbine is

$$\dot{W}_{\text{out}} = \dot{N}W_{\text{out}} = (7.018 \times 10^{-3} \text{ kmol/min})(2,245,164 \text{ kJ/kmol}) = 15,756 \text{ kJ/min} = \mathbf{262.6 \text{ kW}}$$

(c) The entropy generation during this process is determined from

$$S_{\text{gen}} = S_P - S_R + \frac{Q_{\text{out}}}{T_{\text{sur}}} = \sum N_P \bar{s}_P - \sum N_R \bar{s}_R + \frac{Q_{\text{out}}}{T_{\text{sur}}}$$

where the entropy of the products are to be evaluated at the turbine exit state. The C_8H_{18} is at 25°C and 8 atm, and thus its absolute entropy is $\bar{s}_{\text{C}_8\text{H}_{18}} = 360.79 \text{ kJ/kmol}\cdot\text{K}$ (Table A-26). The entropy values listed in the ideal gas tables are for 1 atm pressure. The entropies are to be calculated at the partial pressure of the components which is equal to $P_i = y_i P_{\text{total}}$, where y_i is the mole fraction of component i . Also,

$$S_i = N_i \bar{s}_i(T, P_i) = N_i (\bar{s}_i^\circ(T, P_0) - R_u \ln(y_i P_m))$$

The entropy calculations can be presented in tabular form as

	N_i	y_i	$\bar{s}_i^\circ(\mathbf{T}, \mathbf{1 atm})$	$\mathbf{R}_u \ln(y_i P_m)$	$N_i \bar{s}_i$
C_8H_{18}	1	1.00	360.79	17.288	343.50
O_2	37.5	0.21	220.589	4.313	8,110.34
N_2	141	0.79	206.630	15.329	26,973.44
$S_R = 35,427.28 \text{ kJ/K}$					
CO_2	8	0.0437	266.444	-20.260	2,293.63
H_2O	9	0.0490	230.499	-19.281	2,248.02
O_2	25	0.1366	241.689	-10.787	6,311.90
N_2	141	0.7705	226.389	3.595	31,413.93
$S_P = 42,267.48 \text{ kJ/K}$					

Thus,

$$S_{\text{gen}} = 42,267.48 - 35,427.28 + \frac{109,675 \text{ kJ}}{298 \text{ K}} = 7208.2 \text{ kJ/K (per kmol)}$$

Then the rate of entropy generation becomes

$$\dot{S}_{\text{gen}} = \dot{N}S_{\text{gen}} = (7.018 \times 10^{-3} \text{ kmol/min})(7208.2 \text{ kJ/kmol}\cdot\text{K}) = 50.59 \text{ kJ/min}\cdot\text{K}$$

and

$$\dot{X}_{\text{destruction}} = T_0 \dot{S}_{\text{gen}} = (298 \text{ K})(50.59 \text{ kJ/min}\cdot\text{K}) = 15,076 \text{ kJ/min} = \mathbf{251.3 \text{ kW}}$$

$$\dot{W}_{\text{rev}} = \dot{W} + \dot{X}_{\text{destruction}} = 262.6 + 251.3 = \mathbf{513.9 \text{ kW}}$$

15-111 An expression for the HHV of a gaseous alkane C_nH_{2n+2} in terms of n is to be developed.

Assumptions **1** Combustion is complete. **2** The combustion products contain CO_2 , H_2O , and N_2 . **3** Combustion gases are ideal gases.

Analysis The complete reaction balance for 1 kmol of fuel is

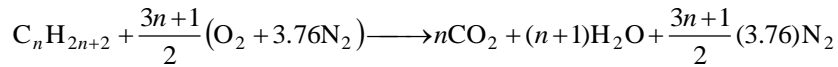

Both the reactants and the products are taken to be at the standard reference state of $25^\circ C$ and 1 atm for the calculation of heating values. The heat transfer for this process is equal to enthalpy of combustion. Note that N_2 and O_2 are stable elements, and thus their enthalpy of formation is zero. Then,

$$q = h_C = H_P - H_R = \sum N_P \bar{h}_{f,P} - \sum N_R \bar{h}_{f,R} = (N\bar{h}_f)_{CO_2} + (N\bar{h}_f)_{H_2O} - (N\bar{h}_f)_{fuel}$$

For the HHV, the water in the products is taken to be liquid. Then,

$$h_C = n(-393,520) + (n+1)(-285,830) - (\bar{h}_f)_{fuel}$$

The HHV of the fuel is

$$HHV = \frac{-h_C}{M_{fuel}} = \frac{n(-393,520) + (n+1)(-285,830) - (\bar{h}_f)_{fuel}}{M_{fuel}}$$

For the LHV, the water in the products is taken to be vapor. Then,

$$LHV = \frac{n(-393,520) + (n+1)(-241,820) - (\bar{h}_f)_{fuel}}{M_{fuel}}$$

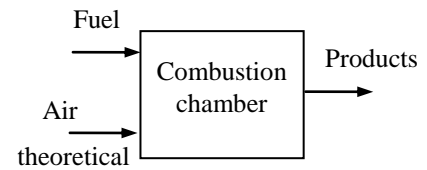

15-112 It is to be shown that the work output of the Carnot engine will be maximum when $T_p = \sqrt{T_0 T_{af}}$. It is also to be shown that the maximum work output of the Carnot engine in this case becomes $w = CT_{af} \left(1 - \frac{\sqrt{T_0}}{\sqrt{T_{af}}}\right)^2$.

Analysis The combustion gases will leave the combustion chamber and enter the heat exchanger at the adiabatic flame temperature T_{af} since the chamber is adiabatic and the fuel is burned completely. The combustion gases experience no change in their chemical composition as they flow through the heat exchanger. Therefore, we can treat the combustion gases as a gas stream with a constant specific heat c_p . Noting that the heat exchanger involves no work interactions, the energy balance equation for this single-stream steady-flow device can be written as

$$\dot{Q} = \dot{m}(h_e - h_i) = \dot{m}C(T_p - T_{af})$$

where \dot{Q} is the negative of the heat supplied to the heat engine. That is,

$$\dot{Q}_H = -\dot{Q} = \dot{m}C(T_{af} - T_p)$$

Then the work output of the Carnot heat engine can be expressed as

$$\dot{W} = \dot{Q}_H \left(1 - \frac{T_0}{T_p}\right) = \dot{m}C(T_{af} - T_p) \left(1 - \frac{T_0}{T_p}\right) \quad (1)$$

Taking the partial derivative of \dot{W} with respect to T_p while holding T_{af} and T_0 constant gives

$$\frac{\partial \dot{W}}{\partial T_p} = 0 \longrightarrow -\dot{m}C \left(1 - \frac{T_0}{T_p}\right) + \dot{m}C(T_{af} - T_p) \frac{T_0}{T_p^2} = 0$$

Solving for T_p we obtain

$$T_p = \sqrt{T_0 T_{af}}$$

which is the temperature at which the work output of the Carnot engine will be a maximum. The maximum work output is determined by substituting the relation above into Eq. (1),

$$\dot{W} = \dot{m}C(T_{af} - T_p) \left(1 - \frac{T_0}{T_p}\right) = \dot{m}C(T_{af} - \sqrt{T_0 T_{af}}) \left(1 - \frac{T_0}{\sqrt{T_0 T_{af}}}\right)$$

It simplifies to

$$\dot{W} = \dot{m}CT_{af} \left(1 - \frac{\sqrt{T_0}}{\sqrt{T_{af}}}\right)^2$$

or

$$w = CT_{af} \left(1 - \frac{\sqrt{T_0}}{\sqrt{T_{af}}}\right)^2$$

which is the desired relation.

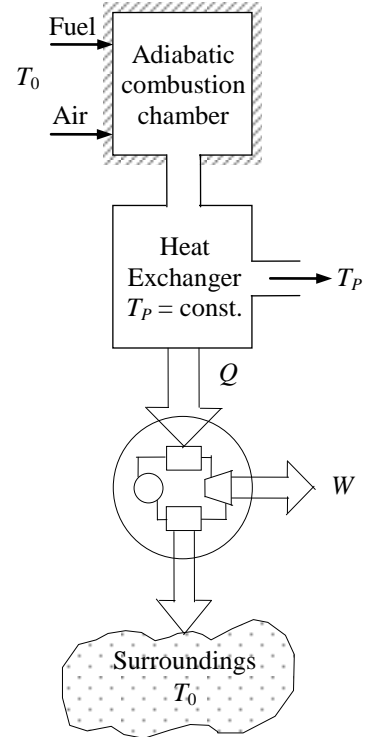

15-113 The combustion of a hydrocarbon fuel C_nH_m with excess air and incomplete combustion is considered. The coefficients of the reactants and products are to be written in terms of other parameters.

Analysis The balanced reaction equation for stoichiometric air is

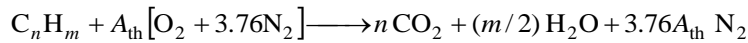

The stoichiometric coefficient A_{th} is determined from an O_2 balance:

$$A_{th} = n + m/4$$

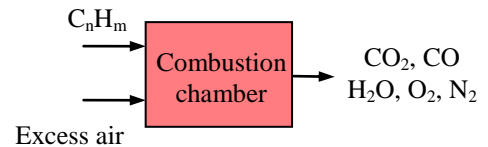

The reaction with excess air and incomplete combustion is

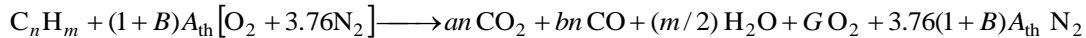

The given reaction is

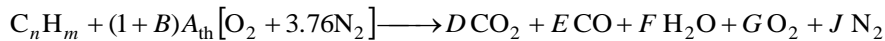

Thus,

$$D = a n$$

$$E = b n$$

$$F = m/2$$

$$J = 3.76(1+B)A_{th}$$

The coefficient G for O_2 is determined from a mass balance,

O_2 balance:

$$\begin{aligned} (1+B)A_{th} &= a n + \frac{b n}{2} + \frac{m}{4} + G \\ (1+B)\left(n + \frac{m}{4}\right) &= a n + \frac{b n}{2} + \frac{m}{4} + G \\ \left(n + \frac{m}{4}\right) + B A_{th} &= a n + \frac{b n}{2} + \frac{m}{4} + G \\ G &= n + B A_{th} - a n - \frac{b n}{2} \\ &= n(1-a) + B A_{th} - \frac{b n}{2} \\ &= n b - \frac{b n}{2} + B A_{th} \\ &= \frac{b n}{2} + B A_{th} \end{aligned}$$

15-114 The combustion of a mixture of an alcohol fuel ($C_nH_mO_x$) and a hydrocarbon fuel (C_wH_z) with excess air and incomplete combustion is considered. The coefficients of the reactants and products are to be written in terms of other parameters.

Analysis The balanced reaction equation for stoichiometric air is

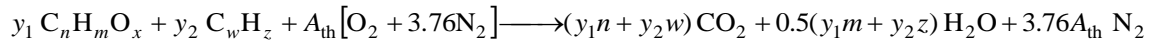

The stoichiometric coefficient A_{th} is determined from an O_2 balance:

$$y_1 x / 2 + A_{th} = (y_1 n + y_2 w) + (y_1 m + y_2 z) / 4 \longrightarrow A_{th} = (y_1 n + y_2 w) + (y_1 m + y_2 z) / 4 - y_1 x / 2$$

The reaction with excess air and incomplete combustion is

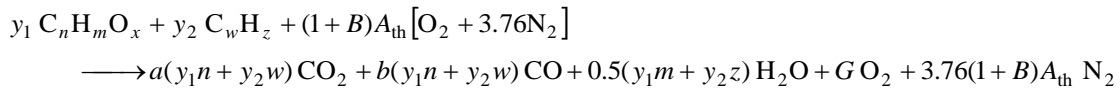

The given reaction is

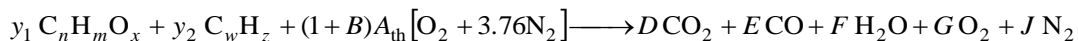

Thus,

$$D = a(y_1 n + y_2 w)$$

$$E = b(y_1 n + y_2 w)$$

$$F = 0.5(y_1 m + y_2 z)$$

$$J = 3.76(1 + B)A_{th}$$

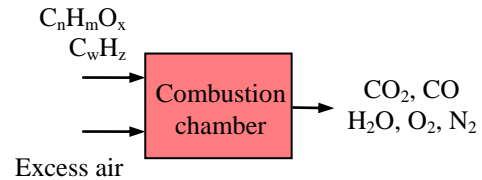

The coefficient G for O_2 is determined from a mass balance,

O_2 balance:

$$0.5y_1 x + (1 + B)A_{th} = a(y_1 n + y_2 w) + 0.5b(y_1 n + y_2 w) + 0.25(y_1 m + y_2 z) + G$$

$$0.5y_1 x + (y_1 n + y_2 w) + 0.25(y_1 m + y_2 z) - 0.5y_1 x + BA_{th} = a(y_1 n + y_2 w) + 0.5b(y_1 n + y_2 w) + 0.25(y_1 m + y_2 z) + G$$

$$G = (y_1 n + y_2 w) - a(y_1 n + y_2 w) - 0.5b(y_1 n + y_2 w) + BA_{th}$$

$$= (y_1 n + y_2 w)(1 - a) - 0.5b(y_1 n + y_2 w) + BA_{th}$$

$$= b(y_1 n + y_2 w) - 0.5b(y_1 n + y_2 w) + BA_{th}$$

$$= 0.5b(y_1 n + y_2 w) + BA_{th}$$



15-115 The adiabatic flame temperature of the fuels $\text{CH}_4(\text{g})$, $\text{C}_2\text{H}_2(\text{g})$, $\text{CH}_3\text{OH}(\text{g})$, $\text{C}_3\text{H}_8(\text{g})$, and $\text{C}_8\text{H}_{18}(\text{l})$ is to be determined.

Analysis The problem is solved using EES, and the solution is given below.

Adiabatic Combustion of fuel C_nH_m entering at T_{fuel} with Stoichiometric Air at T_{air} :

Reaction: $\text{C}_x\text{H}_y\text{O}_z + (y/4 + x-z/2) (\text{Theo_air}/100) (\text{O}_2 + 3.76 \text{N}_2)$

$\leftrightarrow x\text{CO}_2 + (y/2) \text{H}_2\text{O} + 3.76 (y/4 + x-z/2) (\text{Theo_air}/100) \text{N}_2 + (y/4 + x-z/2) (\text{Theo_air}/100 - 1) \text{O}_2$

["For theoretical oxygen, the complete combustion equation for CH_3OH is"

" $\text{CH}_3\text{OH} + A_{\text{th}} \text{O}_2 = 1 \text{CO}_2 + 2 \text{H}_2\text{O}$ "

$1 + 2A_{\text{th}} = 1 + 2 + 2 \cdot 1$ "theoretical O balance"]

" T_{prod} is the adiabatic combustion temperature, assuming no dissociation.

Theo_air is the % theoretical air. "

"The initial guess value of $T_{\text{prod}} = 450\text{K}$."

Procedure Fuel(Fuel\$, T_{fuel} :x,y,z,h_fuel,Name\$)

"This procedure takes the fuel name and returns the moles of C and moles of H"

If fuel\$='C₂H₂(g)' then

x=2; y=2; z=0

Name\$='acetylene'

h_fuel = 226730"Table A.26"

else

If fuel\$='C₃H₈(g)' then

x=3; y=8; z=0

Name\$='propane'

h_fuel = enthalpy(C₃H₈, T= T_{fuel})

else

If fuel\$='C₈H₁₈(l)' then

x=8; y=18; z=0

Name\$='octane'

h_fuel = -249950"Table A.26"

else

if fuel\$='CH₄(g)' then

x=1; y=4; z=0

Name\$='methane'

h_fuel = enthalpy(CH₄, T= T_{fuel})

else

if fuel\$='CH₃OH(g)' then

x=1; y=4; z=1

Name\$='methyl alcohol'

h_fuel = -200670"Table A.26"

endif; endif; endif; endif; endif

end

["Input data from the diagram window"

$T_{\text{air}} = 298$ [K]

$\text{Theo_air} = 200$ [%]

Fuel\$='CH₄(g)'

$T_{\text{fuel}} = 298$ [K]

Call Fuel(Fuel\$, T_{fuel} :x,y,z,h_fuel,Name\$)

$A_{\text{th}} = y/4 + x-z/2$

$\text{Th_air} = \text{Theo_air}/100$

$\text{HR} = h_{\text{fuel}} + (y/4 + x-z/2) * (\text{Theo_air}/100) * \text{enthalpy}(\text{O}_2, T = T_{\text{air}}) + 3.76 * (y/4 + x-z/2) * (\text{Theo_air}/100)$

$* \text{enthalpy}(\text{N}_2, T = T_{\text{air}})$

$\text{HP} = \text{HR}$ "Adiabatic"

$\text{HP} = x * \text{enthalpy}(\text{CO}_2, T = T_{\text{prod}}) + (y/2) * \text{enthalpy}(\text{H}_2\text{O}, T = T_{\text{prod}}) + 3.76 * (y/4 + x-z/2) *$

$(\text{Theo_air}/100) * \text{enthalpy}(\text{N}_2, T = T_{\text{prod}}) + (y/4 + x-z/2) * (\text{Theo_air}/100 - 1) * \text{enthalpy}(\text{O}_2, T = T_{\text{prod}})$

$\text{Moles_O}_2 = (y/4 + x-z/2) * (\text{Theo_air}/100 - 1)$

$\text{Moles_N}_2 = 3.76 * (y/4 + x-z/2) * (\text{Theo_air}/100)$

Moles_CO2=x
 Moles_H2O=y/2
 T[1]=T_prod; xa[1]=Theo_air "array variable are plotted in Plot Window 1"

SOLUTION for a sample calculation

A_th=1.5	fuel\$='CH3OH(g)'	HP=-200733 [kJ/kg]
HR=-200733 [kJ/kg]	h_fuel=-200670	Moles_CO2=1
Moles_H2O=2	Moles_N2=11.280	Moles_O2=1.500
Name\$='methyl alcohol'	Theo_air=200 [%]	Th_air=2
T[1]=1540	T_air=298 [K]	T_fuel=298 [K]
T_prod=1540 [K]	x=1	xa[1]=200 [%]
y=4	z=1	



15-116 The effect of the amount of air on the adiabatic flame temperature of liquid octane (C_8H_{18}) is to be investigated.

Analysis The problem is solved using EES, and the solution is given below.

Adiabatic Combustion of fuel C_nH_m entering at T_{fuel} with Stoichiometric Air at T_{air} :

Reaction: $C_xH_yO_z + (y/4 + x-z/2) (Theo_air/100) (O_2 + 3.76 N_2)$

$\leftrightarrow xCO_2 + (y/2) H_2O + 3.76 (y/4 + x-z/2) (Theo_air/100) N_2 + (y/4 + x-z/2) (Theo_air/100 - 1) O_2$

"For theoretical oxygen, the complete combustion equation for CH_3OH is"

" $CH_3OH + A_{th} O_2 = 1 CO_2 + 2 H_2O$ "

" $1 + 2A_{th} = 1 + 2 + 2$ " "theoretical O balance"

Adiabatic, Incomplete Combustion of fuel C_nH_m entering at T_{fuel} with Stoichiometric Air at T_{air} :

Reaction: $C_xH_yO_z + (y/4 + x-z/2) (Theo_air/100) (O_2 + 3.76 N_2)$

$\leftrightarrow (x-w)CO_2 + wCO + (y/2) H_2O + 3.76 (y/4 + x-z/2) (Theo_air/100) N_2 + ((y/4 + x-z/2) (Theo_air/100 - 1) + w/2)O_2$

" T_{prod} is the adiabatic combustion temperature, assuming no dissociation.

$Theo_air$ is the % theoretical air. "

"The initial guess value of $T_{prod} = 450K$."

Procedure Fuel(Fuel\$, T_{fuel} :x,y,z,h_fuel,Name\$)

"This procedure takes the fuel name and returns the moles of C and moles of H"

If fuel\$='C2H2(g)' then

x=2; y=2; z=0

Name\$='Acetylene'

h_fuel = 226730

else

If fuel\$='C3H8(l)' then

x=3; y=8; z=0

Name\$='Propane(liq)'

h_fuel = -103850-15060

else

If fuel\$='C8H18(l)' then

x=8; y=18; z=0

Name\$='Octane(liq)'

h_fuel = -249950

else

if fuel\$='CH4(g)' then

x=1; y=4; z=0

Name\$='Methane'

h_fuel = enthalpy(CH4,T= T_{fuel})

else

if fuel\$='CH3OH(g)' then

x=1; y=4; z=1

Name\$='Methyl alcohol'

h_fuel = -200670

endif; endif; endif; endif; endif

end

Procedure Moles(x,y,z,Th_air,A_th:w,MolO2,SolMeth\$)

ErrTh = $(2*x + y/2 - z - x)/(2*A_{th}) * 100$

IF Th_air >= 1 then

SolMeth\$ = '>= 100%, the solution assumes complete combustion.'

{MolCO = 0

MolCO2 = x}

w=0

MolO2 = $A_{th} * (Th_{air} - 1)$

GOTO 10

ELSE

w = $2*x + y/2 - z - 2*A_{th} * Th_{air}$

```

IF w > x then
Call ERROR('The moles of CO2 are negative, the percent theoretical air must be >= xxxF3 %',ErrTh)
Else
SolMeth$ = '< 100%, the solution assumes incomplete combustion with no O_2 in products.'
MolO2 = 0
endif; endif
10:
END
{"Input data from the diagram window"
T_air = 298 [K]
Theo_air = 200 "%"
Fuel$='CH4(g)}
T_fuel = 298 [K]
Call Fuel(Fuel$,T_fuel:x,y,z,h_fuel,Name$)
A_th = x + y/4 - z/2
Th_air = Theo_air/100
Call Moles(x,y,z,Th_air,A_th:w,MolO2,SolMeth$)
HR=h_fuel+ (x+y/4-z/2) *(Theo_air/100) *enthalpy(O2,T=T_air)+3.76*(x+y/4-z/2) *(Theo_air/100)
*enthalpy(N2,T=T_air)
HP=HR "Adiabatic"
HP=(x-w)*enthalpy(CO2,T=T_prod)+w*enthalpy(CO,T=T_prod)+(y/2)*enthalpy(H2O,T=T_prod)+3.76*(x+y/4-
z/2)* (Theo_air/100)*enthalpy(N2,T=T_prod)+MolO2*enthalpy(O2,T=T_prod)
Moles_O2=MolO2
Moles_N2=3.76*(x+y/4-z/2)* (Theo_air/100)
Moles_CO2=x-w
Moles_CO=w
Moles_H2O=y/2

```

Theo _{air} [%]	T _{prod} [K]
75	2077
90	2287
100	2396
120	2122
150	1827
200	1506
300	1153
500	840.1
800	648.4

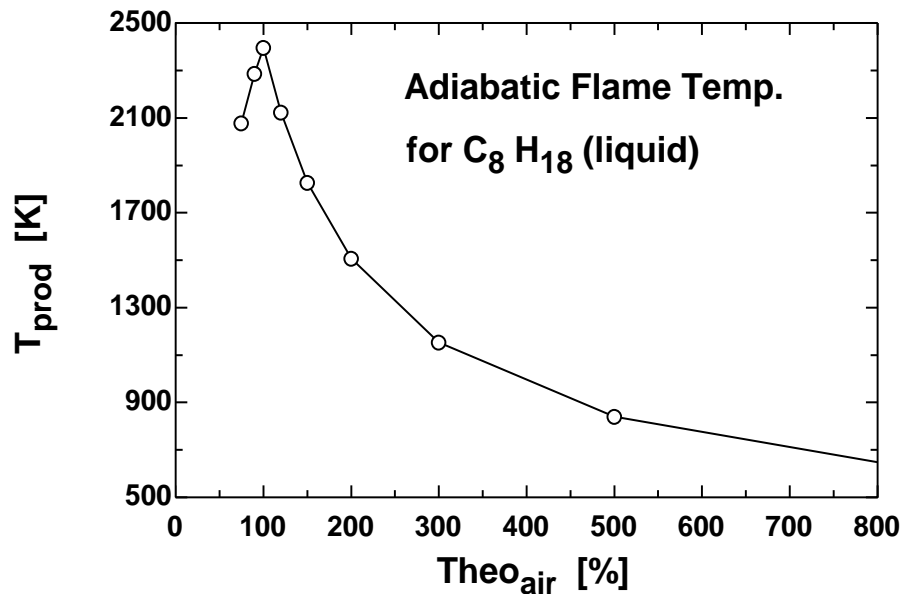



15-117 The fuel among $\text{CH}_4(\text{g})$, $\text{C}_2\text{H}_2(\text{g})$, $\text{C}_2\text{H}_6(\text{g})$, $\text{C}_3\text{H}_8(\text{g})$, and $\text{C}_8\text{H}_{18}(\text{l})$ that gives the highest temperature when burned completely in an adiabatic constant-volume chamber with the theoretical amount of air is to be determined.

Analysis The problem is solved using EES, and the solution is given below.

Adiabatic Combustion of fuel $\text{C}_x\text{H}_y\text{O}_z$ with Stoichiometric Air at $T_{\text{fuel}} = T_{\text{air}} = T_{\text{reac}}$ in a constant volume, closed system:

Reaction: $\text{C}_x\text{H}_y\text{O}_z + (x+y/4-z/2) (\text{Theo_air}/100) (\text{O}_2 + 3.76 \text{ N}_2)$
 $\rightarrow x\text{CO}_2 + (y/2) \text{H}_2\text{O} + 3.76 (x+y/4-z/2) (\text{Theo_air}/100) \text{N}_2 + (x+y/4-z/2) (\text{Theo_air}/100 - 1) \text{O}_2$

"For theoretical oxygen, the complete combustion equation for CH_3OH is"

" $\text{CH}_3\text{OH} + A_{\text{th}} \text{O}_2 = 1 \text{CO}_2 + 2 \text{H}_2\text{O}$ "

" $1 + 2 * A_{\text{th}} = 1 * 2 + 2 * 1$ " "theoretical O balance"

"Adiabatic, Incomplete Combustion of fuel $\text{C}_x\text{H}_y\text{O}_z$ with Stoichiometric Air at $T_{\text{fuel}} = T_{\text{air}} = T_{\text{reac}}$ in a constant volume, closed system:

Reaction: $\text{C}_x\text{H}_y\text{O}_z + (x+y/4-z/2) (\text{Theo_air}/100) (\text{O}_2 + 3.76 \text{ N}_2)$
 $\rightarrow (x-w)\text{CO}_2 + w\text{CO} + (y/2) \text{H}_2\text{O} + 3.76 (x+y/4-z/2) (\text{Theo_air}/100) \text{N}_2 + ((x+y/4-z/2) (\text{Theo_air}/100 - 1) + w/2) \text{O}_2$

" T_{prod} is the adiabatic combustion temperature, assuming no dissociation.

Theo_air is the % theoretical air. "

"The initial guess value of $T_{\text{prod}} = 450\text{K}$."

Procedure Fuel(Fuel\$, T_{fuel} :x,y,z,h_fuel,Name\$)

"This procedure takes the fuel name and returns the moles of C and moles of H"

If fuel\$='C2H2(g)' then

x=2; y=2; z=0

Name\$='acetylene'

h_fuel = 226730 "Table A.26"

else

If fuel\$='C3H8(g)' then

x=3; y=8; z=0

Name\$='propane'

h_fuel = enthalpy(C3H8, T= T_{fuel})

else

If fuel\$='C8H18(l)' then

x=8; y=18; z=0

Name\$='octane'

h_fuel = -249950 "Table A.26"

else

if fuel\$='CH4(g)' then

x=1; y=4; z=0

Name\$='methane'

h_fuel = enthalpy(CH4, T= T_{fuel})

else

if fuel\$='CH3OH(g)' then

x=1; y=4; z=1

Name\$='methyl alcohol'

h_fuel = -200670 "Table A.26"

endif; endif; endif; endif; endif

end

Procedure Moles(x,y,z,Th_air,A_th:w,MolO2,SolMeth\$)

ErrTh = $(2 * x + y/2 - z - x) / (2 * A_{\text{th}}) * 100$

IF Th_air >= 1 then

SolMeth\$ = '>= 100%, the solution assumes complete combustion.'

w=0

MolO2 = $A_{\text{th}} * (\text{Th_air} - 1)$

PROPRIETARY MATERIAL. © 2015 McGraw-Hill Education. Limited distribution permitted only to teachers and educators for course preparation. If you are a student using this Manual, you are using it without permission.

```

GOTO 10
ELSE
  w = 2*x + y/2 - z - 2*A_th*Th_air
IF w > x then
Call ERROR('The moles of CO2 are negative, the percent theoretical air must be >= xxxF3 %',ErrTh)
Else
SolMeth$ = '< 100%, the solution assumes incomplete combustion with no O_2 in products.'
MolO2 = 0
endif; endif
10:
END

```

```

{"Input data from the diagram window"

```

```

Theo_air = 200 [%]
Fuel$='CH4(g)'}

```

```

T_reac = 298 [K]
T_air = T_reac
T_fuel = T_reac
R_u = 8.314 [kJ/kmol-K]
Call Fuel(Fuel$,T_fuel:x,y,z,h_fuel,Name$)
A_th = x + y/4 - z/2
Th_air = Theo_air/100
Call Moles(x,y,z,Th_air,A_th:w,MolO2,SolMeth$)
UR=(h_fuel-R_u*T_fuel)+ (x+y/4-z/2) *(Theo_air/100) *(enthalpy(O2,T=T_air)-R_u*T_air)+3.76*(x+y/4-z/2)
*(Theo_air/100) *(enthalpy(N2,T=T_air)-R_u*T_air)
UP=(x-w)*(enthalpy(CO2,T=T_prod)-R_u*T_prod)+w*(enthalpy(CO,T=T_prod)-
R_u*T_prod)+(y/2)*(enthalpy(H2O,T=T_prod)-R_u*T_prod)+3.76*(x+y/4-z/2)*
(Theo_air/100)*(enthalpy(N2,T=T_prod)-R_u*T_prod)+MolO2*(enthalpy(O2,T=T_prod)-R_u*T_prod)

```

```

UR =UP "Adiabatic, constant volume conservation of energy"

```

```

Moles_O2=MolO2
Moles_N2=3.76*(x+y/4-z/2)* (Theo_air/100)
Moles_CO2=x-w
Moles_CO=w
Moles_H2O=y/2

```

SOLUTION for CH4

A_th=2	fuel\$='CH4(g)'	h_fuel=-74875
Moles_CO=0.000	Moles_CO2=1.000	Moles_H2O=2
Moles_N2=7.520	Moles_O2=0.000	MolO2=0
Name\$='methane'	R_u=8.314 [kJ/kmol-K]	
SolMeth\$='>= 100%, the solution assumes complete combustion.'		
Theo_air=100 [%]	Th_air=1.000	T_air=298 [K]
T_fuel=298 [K]	T_prod=2824 [K]	T_reac=298 [K]
UP=-100981	UR=-100981	w=0
x=1	y=4	z=0

SOLUTION for C2H2

A_th=2.5	fuel\$='C2H2(g)'	h_fuel=226730
Moles_CO=0.000	Moles_CO2=2.000	Moles_H2O=1
Moles_N2=9.400	Moles_O2=0.000	MolO2=0
Name\$='acetylene'	R_u=8.314 [kJ/kmol-K]	
SolMeth\$='>= 100%, the solution assumes complete combustion.'		
Theo_air=100 [%]	Th_air=1.000	T_air=298 [K]
T_fuel=298 [K]	T_prod=3535 [K]	T_reac=298 [K]
UP=194717	UR=194717	w=0
x=2	y=2	z=0

SOLUTION for CH3OH

A_th=1.5	fuel\$='CH3OH(g)'	h_fuel=-200670
Moles_CO=0.000	Moles_CO2=1.000	Moles_H2O=2
Moles_N2=5.640	Moles_O2=0.000	MolO2=0
Name\$='methyl alcohol'	R_u=8.314 [kJ/kmol-K]	
SolMeth\$='>= 100%, the solution assumes complete combustion.'		
Theo_air=100 [%]	Th_air=1.000	T_air=298 [K]
T_fuel=298 [K]	T_prod=2817 [K]	T_reac=298 [K]
UP=-220869	UR=-220869	w=0
x=1	y=4	z=1

SOLUTION for C3H8

A_th=5	fuel\$='C3H8(g)'	h_fuel=-103858
Moles_CO=0.000	Moles_CO2=3.000	Moles_H2O=4
Moles_N2=18.800	Moles_O2=0.000	MolO2=0
Name\$='propane'	R_u=8.314 [kJ/kmol-K]	
SolMeth\$='>= 100%, the solution assumes complete combustion.'		
Theo_air=100 [%]	Th_air=1.000	T_air=298 [K]
T_fuel=298 [K]	T_prod=2909 [K]	T_reac=298 [K]
UP=-165406	UR=-165406	w=0
x=3	y=8	z=0

SOLUTION for C8H18

A_th=12.5	fuel\$='C8H18(l)'	h_fuel=-249950
Moles_CO=0.000	Moles_CO2=8.000	Moles_H2O=9
Moles_N2=47.000	Moles_O2=0.000	MolO2=0
Name\$='octane'	R_u=8.314 [kJ/kmol-K]	
SolMeth\$='>= 100%, the solution assumes complete combustion.'		
Theo_air=100 [%]	Th_air=1.000	T_air=298 [K]
T_fuel=298 [K]	T_prod=2911 [K]	T_reac=298 [K]
UP=-400104	UR=-400104	w=0
x=8	y=18	z=0



15-118 A general program is to be written to determine the heat transfer during the complete combustion of a hydrocarbon fuel C_nH_m at 25°C in a steady-flow combustion chamber when the percent of excess air and the temperatures of air and the products are specified.

Analysis The problem is solved using EES, and the solution is given below.

Steady-flow combustion of fuel C_nH_m entering at T_{fuel} with Stoichiometric Air at T_{air} :

Reaction: $C_xH_yO_z + (x+y/4-z/2) (\text{Theo_air}/100) (\text{O}_2 + 3.76 \text{N}_2)$

--> $x\text{CO}_2 + (y/2) \text{H}_2\text{O} + 3.76 (x+y/4-z/2) (\text{Theo_air}/100) \text{N}_2 + (x+y/4-z/2) (\text{Theo_air}/100 - 1) \text{O}_2$

"For theoretical oxygen, the complete combustion equation for CH_3OH is"

" $\text{CH}_3\text{OH} + A_{\text{th}} \text{O}_2 = 1 \text{CO}_2 + 2 \text{H}_2\text{O}$ "

" $1 + 2A_{\text{th}} = 1 + 2 \times 1$ " "theoretical O balance"

"Steady-flow, Incomplete Combustion of fuel C_nH_m entering at T_{fuel} with Stoichiometric Air at T_{air} :

Reaction: $C_xH_yO_z + (x+y/4-z/2) (\text{Theo_air}/100) (\text{O}_2 + 3.76 \text{N}_2)$

--> $(x-w)\text{CO}_2 + w\text{CO} + (y/2) \text{H}_2\text{O} + 3.76 (x+y/4-z/2) (\text{Theo_air}/100) \text{N}_2 + ((x+y/4-z/2) (\text{Theo_air}/100 - 1) + w/2) \text{O}_2$

" T_{prod} is the product gas temperature, assuming no dissociation.

Theo_air is the % theoretical air. "

Procedure Fuel(Fuel\$, T_{fuel} :x,y,z,h_fuel,Name\$,MM)

"This procedure takes the fuel name and returns the moles of C and moles of H"

If fuel\$='C2H2(g)' then

x=2; y=2; z=0

Name\$='Acetylene'

h_fuel = 226730 "Table A.26"

MM=2*12+2*1

else

If fuel\$='C3H8(l)' then

x=3; y=8; z=0

Name\$='Propane(liq)'

h_fuel = -103850-15060 "Tables A.26 and A.27"

MM=molarmass(C3H8)

else

If fuel\$='C8H18(l)' then

x=8; y=18; z=0

Name\$='Octane(liq)'

h_fuel = -249950 "Table A.26"

MM=8*12+18*1

else

if fuel\$='CH4(g)' then

x=1; y=4; z=0

Name\$='Methane'

h_fuel = enthalpy(CH4, T= T_{fuel})

MM=molarmass(CH4)

else

if fuel\$='CH3OH(g)' then

x=1; y=4; z=1

Name\$='Methyl alcohol'

h_fuel = -200670 "Table A.26"

MM=1*12+4*1+1*16

endif; endif; endif; endif; endif

end

Procedure Moles(x,y,z,Th_air,A_th:w,MolO2,SolMeth\$)

ErrTh = $(2*x + y/2 - z - x)/(2*A_{\text{th}}) * 100$

IF Th_air >= 1 then

SolMeth\$ = '>= 100%, the solution assumes complete combustion.'

w=0

```

MolO2 = A_th*(Th_air - 1)
GOTO 10
ELSE
  w = 2*x + y/2 - z - 2*A_th*Th_air
IF w > x then
Call ERROR('The moles of CO2 are negative, the percent theoretical air must be >= xxxF3 %',ErrTh)
Else
SolMeth$ = '< 100%, the solution assumes incomplete combustion with no O_2 in products.'
MolO2 = 0
endif; endif
10:
END
{"Input data from the diagram window"
T_air = 298 [K]
Theo_air = 200 [%]
Fuel$='CH4(g)}
T_fuel = 298 [K]
Call Fuel(Fuel$,T_fuel:x,y,z,h_fuel,Name$,MM)
A_th =x + y/4 - z/2
Th_air = Theo_air/100
Call Moles(x,y,z,Th_air,A_th:w,MolO2,SolMeth$)
HR=h_fuel+ (x+y/4-z/2) *(Theo_air/100) *enthalpy(O2,T=T_air)+3.76*(x+y/4-z/2) *(Theo_air/100)
*enthalpy(N2,T=T_air)
HP=(x-w)*enthalpy(CO2,T=T_prod)+w*enthalpy(CO,T=T_prod)+(y/2)*enthalpy(H2O,T=T_prod)+3.76*(x+y/4-
z/2)* (Theo_air/100)*enthalpy(N2,T=T_prod)+MolO2*enthalpy(O2,T=T_prod)
Q_out=(HR-HP)/MM "kJ/kg_fuel"
Moles_O2=MolO2
Moles_N2=3.76*(x+y/4-z/2) *(Theo_air/100)
Moles_CO2=x-w
Moles_CO=w
Moles_H2O=y/2

```

SOLUTION for the sample calculation

```

A_th=5 fuel$='C3H8(l)'
HP=-149174 [kJ/kg]          HR=-119067 [kJ/kg]
h_fuel=-118910             MM=44.1 [kg/kmol]
Moles_CO=0.000            Moles_CO2=3.000
Moles_H2O=4               Moles_N2=28.200
Moles_O2=2.500           MolO2=2.5
Name$='Propane(liq)'      Q_out=682.8 [kJ/kg_fuel]
SolMeth$='>= 100%, the solution assumes complete combustion.'
Theo_air=150 [%]         Th_air=1.500
T_air=298 [K]           T_fuel=298 [K]
T_prod=1800 [K]         w=0          x=3          y=8          z=0

```



15-119 The rate of heat transfer is to be determined for the fuels $\text{CH}_4(\text{g})$, $\text{C}_2\text{H}_2(\text{g})$, $\text{CH}_3\text{OH}(\text{g})$, $\text{C}_3\text{H}_8(\text{g})$, and $\text{C}_8\text{H}_{18}(\text{l})$ when they are burned completely in a steady-flow combustion chamber with the theoretical amount of air.

Analysis The problem is solved using EES, and the solution is given below.

Steady-flow combustion of fuel $\text{C}_x\text{H}_y\text{O}_z$ entering at T_{fuel} with Stoichiometric Air at T_{air} :

Reaction: $\text{C}_x\text{H}_y\text{O}_z + (x+y/4-z/2) (\text{Theo_air}/100) (\text{O}_2 + 3.76 \text{ N}_2)$

$\rightarrow x\text{CO}_2 + (y/2) \text{H}_2\text{O} + 3.76 (x+y/4-z/2) (\text{Theo_air}/100) \text{N}_2 + (x+y/4-z/2) (\text{Theo_air}/100 - 1) \text{O}_2$

"For theoretical oxygen, the complete combustion equation for CH_3OH is"

" $\text{CH}_3\text{OH} + A_{\text{th}} \text{O}_2 = 1 \text{CO}_2 + 2 \text{H}_2\text{O}$ "

" $1 + 2A_{\text{th}} = 1 + 2 + 2$ " "theoretical O balance"

"Steady-flow, Incomplete Combustion of fuel $\text{C}_x\text{H}_y\text{O}_z$ entering at T_{fuel} with Stoichiometric Air at T_{air} :

Reaction: $\text{C}_x\text{H}_y\text{O}_z + (x+y/4-z/2) (\text{Theo_air}/100) (\text{O}_2 + 3.76 \text{ N}_2)$

$\rightarrow (x-w)\text{CO}_2 + w\text{CO} + (y/2) \text{H}_2\text{O} + 3.76 (x+y/4-z/2) (\text{Theo_air}/100) \text{N}_2 + ((x+y/4-z/2) (\text{Theo_air}/100 - 1) + w/2)\text{O}_2$

" T_{prod} is the product gas temperature, assuming no dissociation.

Theo_air is the % theoretical air. "

Procedure Fuel(Fuel\$, T_{fuel} :x,y,z,h_fuel,Name\$,MM)

"This procedure takes the fuel name and returns the moles of C ,H and O and molar mass"

If fuel\$='C2H2(g)' then

x=2; y=2; z=0

Name\$='acetylene'

h_fuel = 226730

MM=2*12+2*1

else

If fuel\$='C3H8(g)' then

x=3; y=8; z=0

Name\$='propane'

h_fuel = enthalpy(C3H8,T= T_{fuel})

MM=molarmass(C3H8)

else

If fuel\$='C8H18(l)' then

x=8; y=18; z=0

Name\$='octane'

h_fuel = -249950

MM=8*12+18*1

else

if fuel\$='CH4(g)' then

x=1; y=4; z=0

Name\$='methane'

h_fuel = enthalpy(CH4,T= T_{fuel})

MM=molarmass(CH4)

else

if fuel\$='CH3OH(g)' then

x=1; y=4; z=1

Name\$='methyl alcohol'

h_fuel = -200670

MM=1*12+4*1+1*16

endif; endif; endif; endif; endif

end

Procedure Moles(x,y,z,Th_air,A_th:w,MolO2,SolMeth\$)

ErrTh = $(2*x + y/2 - z - x)/(2*A_{\text{th}})*100$

IF Th_air >= 1 then

SolMeth\$ = '>= 100%, the solution assumes complete combustion.'

w=0

MolO2 = $A_{\text{th}}*(Th_{\text{air}} - 1)$

GOTO 10

```

ELSE
  w = 2*x + y/2 - z - 2*A_th*Th_air
IF w > x then
Call ERROR('The moles of CO2 are negative, the percent theoretical air must be >= xxxF3 %',ErrTh)
Else
SolMeth$ = '< 100%, the solution assumes incomplete combustion with no O_2 in products.'
MolO2 = 0
endif; endif
10:
END
{"Input data from the diagram window"
m_dot_fuel = 0.1 [kg/s]
T_air = 298 [K]
Theo_air = 200 [%]
Fuel$='CH4(g)}
T_fuel = 298 [K]
Call Fuel(Fuel$,T_fuel:x,y,z,h_fuel,Name$,MM)
A_th =x + y/4 - z/2
Th_air = Theo_air/100
Call Moles(x,y,z,Th_air,A_th:w,MolO2,SolMeth$)
HR=h_fuel+ (x+y/4-z/2) *(Theo_air/100) *enthalpy(O2,T=T_air)+3.76*(x+y/4-z/2) *(Theo_air/100)
*enthalpy(N2,T=T_air)
HP=(x-w)*enthalpy(CO2,T=T_prod)+w*enthalpy(CO,T=T_prod)+(y/2)*enthalpy(H2O,T=T_prod)+3.76*(x+y/4-
z/2)* (Theo_air/100)*enthalpy(N2,T=T_prod)+MolO2*enthalpy(O2,T=T_prod)
HR =Q_out+HP

"The heat transfer rate is:"
Q_dot_out=Q_out/MM*m_dot_fuel "[kW]"
Moles_O2=MolO2
Moles_N2=3.76*(x+y/4-z/2) * (Theo_air/100)
Moles_CO2=x-w
Moles_CO=w
Moles_H2O=y/2

```

SOLUTION for a sample calculation

A_th=1.5	fuel\$='CH3OH(g)'	HP=-604942 [kJ/kg]
HR=-200701 [kJ/kg]	h_fuel=-200670	MM=32
Moles_CO=0.000	Moles_CO2=1.000	Moles_H2O=2
Moles_N2=5.640	Moles_O2=0.000	MolO2=0
m_dot_fuel=1 [kg/s]	Name\$='methyl alcohol'	Q_dot_out=12633 [kW]
Q_out=404241.1 [kJ/kmol_fuel]		
SolMeth\$='>= 100%, the solution assumes complete combustion.'		
Theo_air=100 [%]	Th_air=1.000	T_air=298 [K]
T_fuel=298 [K]	T_prod=1200 [K]	w=0
x=1	y=4	z=1



15-120 The rates of heat transfer are to be determined for the fuels $\text{CH}_4(\text{g})$, $\text{C}_2\text{H}_2(\text{g})$, $\text{CH}_3\text{OH}(\text{g})$, $\text{C}_3\text{H}_8(\text{g})$, and $\text{C}_8\text{H}_{18}(\text{l})$ when they are burned in a steady-flow combustion chamber with for 50, 100, and 200 percent excess air.

Analysis The problem is solved using EES, and the solution is given below.

Steady-flow combustion of fuel $\text{C}_x\text{H}_y\text{O}_z$ entering at T_{fuel} with Stoichiometric Air at T_{air} :

Reaction: $\text{C}_x\text{H}_y\text{O}_z + (x+y/4-z/2) (\text{Theo_air}/100) (\text{O}_2 + 3.76 \text{N}_2)$

$\rightarrow x\text{CO}_2 + (y/2) \text{H}_2\text{O} + 3.76 (x+y/4-z/2) (\text{Theo_air}/100) \text{N}_2 + (x+y/4-z/2) (\text{Theo_air}/100 - 1) \text{O}_2$

"For theoretical oxygen, the complete combustion equation for CH_3OH is"

" $\text{CH}_3\text{OH} + \text{A_th} \text{O}_2 = 1 \text{CO}_2 + 2 \text{H}_2\text{O}$ "

" $1 + 2 \cdot \text{A_th} = 1 \cdot 2 + 2 \cdot 1$ " "theoretical O balance"

"Steady-flow, Incomplete Combustion of fuel $\text{C}_x\text{H}_y\text{O}_z$ entering at T_{fuel} with Stoichiometric Air at T_{air} :

Reaction: $\text{C}_x\text{H}_y\text{O}_z + (x+y/4-z/2) (\text{Theo_air}/100) (\text{O}_2 + 3.76 \text{N}_2)$

$\rightarrow (x-w)\text{CO}_2 + w\text{CO} + (y/2) \text{H}_2\text{O} + 3.76 (x+y/4-z/2) (\text{Theo_air}/100) \text{N}_2 + ((x+y/4-z/2) (\text{Theo_air}/100 - 1) + w/2) \text{O}_2$ "

" T_{prod} is the product gas temperature, assuming no dissociation.

Theo_air is the % theoretical air. "

Procedure Fuel(Fuel\$, T_{fuel} :x,y,z,h_fuel,Name\$,MM)

"This procedure takes the fuel name and returns the moles of C and moles of H"

If fuel\$='C2H2(g)' then

x=2; y=2; z=0

Name\$='acetylene'

h_fuel = 226730

MM=2*12+2*1

else

If fuel\$='C3H8(g)' then

x=3; y=8; z=0

Name\$='propane'

h_fuel = enthalpy(C3H8,T= T_{fuel})

MM=molarmass(C3H8)

else

If fuel\$='C8H18(l)' then

x=8; y=18; z=0

Name\$='octane'

h_fuel = -249950

MM=8*12+18*1

else

if fuel\$='CH4(g)' then

x=1; y=4; z=0

Name\$='methane'

h_fuel = enthalpy(CH4,T= T_{fuel})

MM=molarmass(CH4)

else

if fuel\$='CH3OH(g)' then

x=1; y=4; z=1

Name\$='methyl alcohol'

h_fuel = -200670

MM=1*12+4*1+1*16

endif; endif; endif; endif; endif

end

Procedure Moles(x,y,z,Th_air,A_th:w,MolO2,SolMeth\$)

ErrTh = (2*x + y/2 - z - x)/(2*A_th)*100

IF Th_air >= 1 then

SolMeth\$ = '>= 100%, the solution assumes complete combustion.'

w=0

MolO2 = A_th*(Th_air - 1)

GOTO 10

ELSE

w = 2*x + y/2 - z - 2*A_th*Th_air

IF w > x then

Call ERROR('The moles of CO2 are negative, the percent theoretical air must be >= xxxF3 %',ErrTh)

Else

SolMeth\$ = '< 100%, the solution assumes incomplete combustion with no O_2 in products.'

MolO2 = 0

endif; endif

10:

END

{"Input data from the diagram window"

T_air = 298 [K]

m_dot_fuel=1 [kg/s]

Theo_air = 200 [%]

Fuel\$='CH4(g)'

T_fuel = 298 [K]

Call Fuel(Fuel\$,T_fuel:x,y,z,h_fuel,Name\$,MM)

A_th = x + y/4 - z/2

Th_air = Theo_air/100

Call Moles(x,y,z,Th_air,A_th:w,MolO2,SolMeth\$)

HR=h_fuel+ (x+y/4-z/2) *(Theo_air/100) *enthalpy(O2,T=T_air)+3.76*(x+y/4-z/2) *(Theo_air/100)

*enthalpy(N2,T=T_air)

HP=(x-w)*enthalpy(CO2,T=T_prod)+w*enthalpy(CO,T=T_prod)+(y/2)*enthalpy(H2O,T=T_prod)+3.76*(x+y/4-z/2) *(Theo_air/100)*enthalpy(N2,T=T_prod)+MolO2*enthalpy(O2,T=T_prod)

HR =Q_out+HP

"The heat transfer rate is:"

Q_dot_out=Q_out/MM*m_dot_fuel

Moles_O2=MolO2

Moles_N2=3.76*(x+y/4-z/2) *(Theo_air/100)

Moles_CO2=x-w

Moles_CO=w

Moles_H2O=y/2

SOLUTION for a sample calculation

A_th=12.5

HR=-250472 [kJ/kg]

Moles_CO=0.000

Moles_N2=94.000

m_dot_fuel=1 [kg/s]

Q_out=1390433.6 [kJ/kmol_fuel]

SolMeth\$='>= 100%, the solution assumes complete combustion.'

Theo_air=200 [%]

T_fuel=298 [K]

x=8

fuel\$='C8H18(l)'

h_fuel=-249950

Moles_CO2=8.000

Moles_O2=12.500

Name\$='octane'

Th_air=2.000

T_prod=1200 [K]

T_fuel=298 [K]

T_prod=1200 [K]

y=18

HP=-1.641E+06 [kJ/kg]

MM=114 [kg/kmol]

Moles_H2O=9

MolO2=12.5

Q_dot_out=12197 [kW]

T_air=298 [K]

T_air=298 [K]

T_air=298 [K]

w=0

z=0

Fundamentals of Engineering (FE) Exam Problems

15-121 A fuel is burned steadily in a combustion chamber. The combustion temperature will be the highest except when

- (a) the fuel is preheated.
- (b) the fuel is burned with a deficiency of air.
- (c) the air is dry.
- (d) the combustion chamber is well insulated.
- (e) the combustion is complete.

Answer (b) the fuel is burned with a deficiency of air.

15-122 A fuel is burned with 70 percent theoretical air. This is equivalent to

- (a) 30% excess air
- (b) 70% excess air
- (c) 30% deficiency of air
- (d) 70% deficiency of air
- (e) stoichiometric amount of air

Answer (c) 30% deficiency of air

Solution Solved by EES Software. Solutions can be verified by copying-and-pasting the following lines on a blank EES screen. (Similar problems and their solutions can be obtained easily by modifying numerical values).

```
air_th=0.7
"air_th=air_access+1"
air_th=1-air_deficiency
```

15-123 Propane C_3H_8 is burned with 150 percent theoretical air. The air-fuel mass ratio for this combustion process is

- (a) 5.3
- (b) 10.5
- (c) 15.7
- (d) 23.4
- (e) 39.3

Answer (d) 23.4

Solution Solved by EES Software. Solutions can be verified by copying-and-pasting the following lines on a blank EES screen. (Similar problems and their solutions can be obtained easily by modifying numerical values).

```
n_C=3
n_H=8
m_fuel=n_H*1+n_C*12
a_th=n_C+n_H/4
coeff=1.5 "coeff=1 for theoretical combustion, 1.5 for 50% excess air"
n_O2=coeff*a_th
n_N2=3.76*n_O2
m_air=n_O2*32+n_N2*28
AF=m_air/m_fuel
```

15-124 One kmol of methane (CH_4) is burned with an unknown amount of air during a combustion process. If the combustion is complete and there are 1 kmol of free O_2 in the products, the air-fuel mass ratio is

- (a) 34.6 (b) 25.7 (c) 17.2 (d) 14.3 (e) 11.9

Answer (b) 25.7

Solution Solved by EES Software. Solutions can be verified by copying-and-pasting the following lines on a blank EES screen. (Similar problems and their solutions can be obtained easily by modifying numerical values).

```
n_C=1
n_H=4
m_fuel=n_H*1+n_C*12
a_th=n_C+n_H/4
(coeff-1)*a_th=1 "O2 balance: Coeff=1 for theoretical combustion, 1.5 for 50% excess air"
n_O2=coeff*a_th
n_N2=3.76*n_O2
m_air=n_O2*32+n_N2*28
AF=m_air/m_fuel
```

"Some Wrong Solutions with Common Mistakes:"

W1_AF=1/AF "Taking the inverse of AF"

W2_AF=(n_O2+n_N2) "Finding air-fuel mole ratio"

W3_AF=AF/coeff "Ignoring excess air"

15-125 An equimolar mixture of carbon dioxide and water vapor at 1 atm and 60°C enter a dehumidifying section where the entire water vapor is condensed and removed from the mixture, and the carbon dioxide leaves at 1 atm and 60°C . The entropy change of carbon dioxide in the dehumidifying section is

- (a) $-2.8 \text{ kJ/kg}\cdot\text{K}$ (b) $-0.13 \text{ kJ/kg}\cdot\text{K}$ (c) 0 (d) $0.13 \text{ kJ/kg}\cdot\text{K}$ (e) $2.8 \text{ kJ/kg}\cdot\text{K}$

Answer (b) $-0.13 \text{ kJ/kg}\cdot\text{K}$

Solution Solved by EES Software. Solutions can be verified by copying-and-pasting the following lines on a blank EES screen. (Similar problems and their solutions can be obtained easily by modifying numerical values).

```
Cp_CO2=0.846
R_CO2=0.1889
T1=60+273 "K"
T2=T1
P1= 1 "atm"
P2=1 "atm"
y1_CO2=0.5; P1_CO2=y1_CO2*P1
y2_CO2=1; P2_CO2=y2_CO2*P2
Ds_CO2=Cp_CO2*ln(T2/T1)-R_CO2*ln(P2_CO2/P1_CO2)
```

"Some Wrong Solutions with Common Mistakes:"

W1_Ds=0 "Assuming no entropy change"

W2_Ds=Cp_CO2*ln(T2/T1)-R_CO2*ln(P1_CO2/P2_CO2) "Using pressure fractions backwards"

15-126 Methane (CH_4) is burned completely with 80% excess air during a steady-flow combustion process. If both the reactants and the products are maintained at 25°C and 1 atm and the water in the products exists in the liquid form, the heat transfer from the combustion chamber per unit mass of methane is

- (a) 890 MJ/kg (b) 802 MJ/kg (c) 75 MJ/kg (d) 56 MJ/kg (e) 50 MJ/kg

Answer (d) 56 MJ/kg

Solution Solved by EES Software. Solutions can be verified by copying-and-pasting the following lines on a blank EES screen. (Similar problems and their solutions can be obtained easily by modifying numerical values).

```
T= 25 "C"
P=1 "atm"
EXCESS=0.8
"Heat transfer in this case is the HHV at room temperature,"
HHV_CH4 =55.53 "MJ/kg"
LHV_CH4 =50.05 "MJ/kg"
```

"Some Wrong Solutions with Common Mistakes:"

```
W1_Q=LHV_CH4 "Assuming lower heating value"
W2_Q=EXCESS*hHV_CH4 "Assuming Q to be proportional to excess air"
```

15-127 The higher heating value of a hydrocarbon fuel C_nH_m with $m = 8$ is given to be 1560 MJ/kmol of fuel. Then its lower heating value is

- (a) 1384 MJ/kmol (b) 1208 MJ/kmol (c) 1402 MJ/kmol (d) 1540 MJ/kmol (e) 1550 MJ/kmol

Answer (a) 1384 MJ/kmol

Solution Solved by EES Software. Solutions can be verified by copying-and-pasting the following lines on a blank EES screen. (Similar problems and their solutions can be obtained easily by modifying numerical values).

```
HHV=1560 "MJ/kmol fuel"
h_fg=2.4423 "MJ/kg, Enthalpy of vaporization of water at 25C"
n_H=8
n_water=n_H/2
m_water=n_water*18
LHV=HHV-h_fg*m_water
```

"Some Wrong Solutions with Common Mistakes:"

```
W1_LHV=HHV - h_fg*n_water "Using mole numbers instead of mass"
W2_LHV= HHV - h_fg*m_water*2 "Taking mole numbers of H2O to be m instead of m/2"
W3_LHV= HHV - h_fg*n_water*2 "Taking mole numbers of H2O to be m instead of m/2, and using mole numbers"
```

15-128 Acetylene gas (C_2H_2) is burned completely during a steady-flow combustion process. The fuel and the air enter the combustion chamber at $25^\circ C$, and the products leave at 1500 K . If the enthalpy of the products relative to the standard reference state is -404 MJ/kmol of fuel, the heat transfer from the combustion chamber is

- (a) 177 MJ/kmol (b) 227 MJ/kmol (c) 404 MJ/kmol (d) 631 MJ/kmol (e) 751 MJ/kmol

Answer (d) 631 MJ/kmol

Solution Solved by EES Software. Solutions can be verified by copying-and-pasting the following lines on a blank EES screen. (Similar problems and their solutions can be obtained easily by modifying numerical values).

```
hf_fuel=226730/1000 "MJ/kmol fuel"
H_prod=-404 "MJ/kmol fuel"
H_react=hf_fuel
Q_out=H_react-H_prod
```

"Some Wrong Solutions with Common Mistakes:"

```
W1_Qout= -H_prod "Taking Qout to be H_prod"
W2_Qout= H_react+H_prod "Adding enthalpies instead of subtracting them"
```

15-129 Benzene gas (C_6H_6) is burned with 95 percent theoretical air during a steady-flow combustion process. The mole fraction of the CO in the products is

- (a) 8.3% (b) 4.7% (c) 2.1% (d) 1.9% (e) 14.3%

Answer (c) 2.1%

Solution Solved by EES Software. Solutions can be verified by copying-and-pasting the following lines on a blank EES screen. (Similar problems and their solutions can be obtained easily by modifying numerical values).

```
n_C=6
n_H=6
a_th=n_C+n_H/4
coeff=0.95 "coeff=1 for theoretical combustion, 1.5 for 50% excess air"
"Assuming all the H burns to H2O, the combustion equation is
  C6H6+coeff*a_th(O2+3.76N2)----- (n_CO2) CO2+(n_CO)CO+(n_H2O) H2O+(n_N2) N2"
n_O2=coeff*a_th
n_N2=3.76*n_O2
n_H2O=n_H/2
n_CO2+n_CO=n_C
2*n_CO2+n_CO+n_H2O=2*n_O2 "Oxygen balance"
n_prod=n_CO2+n_CO+n_H2O+n_N2 "Total mole numbers of product gases"
y_CO=n_CO/n_prod "mole fraction of CO in product gases"
```

"Some Wrong Solutions with Common Mistakes:"

```
W1_yCO=n_CO/n1_prod; n1_prod=n_CO2+n_CO+n_H2O "Not including N2 in n_prod"
W2_yCO=(n_CO2+n_CO)/n_prod "Using both CO and CO2 in calculations"
```

15-130 A fuel is burned during a steady-flow combustion process. Heat is lost to the surroundings at 300 K at a rate of 1120 kW. The entropy of the reactants entering per unit time is 17 kW/K and that of the products is 15 kW/K. The total rate of exergy destruction during this combustion process is

- (a) 520 kW (b) 600 kW (c) 1120 kW (d) 340 kW (e) 739 kW

Answer (a) 520 kW

Solution Solved by EES Software. Solutions can be verified by copying-and-pasting the following lines on a blank EES screen. (Similar problems and their solutions can be obtained easily by modifying numerical values).

```
To=300 "K"
Q_out=1120 "kW"
S_react=17 "kW/K"
S_prod= 15 "kW/K"
S_react-S_prod-Q_out/To+S_gen=0 "Entropy balance for steady state operation, Sin-Sout+Sgen=0"
X_dest=To*S_gen
```

"Some Wrong Solutions with Common Mistakes:"

```
W1_Xdest=S_gen "Taking Sgen as exergy destruction"
W2_Xdest=To*S_gen1; S_react-S_prod-S_gen1=0 "Ignoring Q_out/To"
```

15-131 ... 15-136 Design and Essay Problems

15-134 A certain industrial process generates a liquid solution of ethanol and water as the waste product. The solution is to be burned using methane. A combustion process is to be developed to accomplish this incineration process with minimum amount of methane.

Analysis The mass flow rate of the liquid ethanol-water solution is given to be 10 kg/s. Considering that the mass fraction of ethanol in the solution is 0.2,

$$\begin{aligned}\dot{m}_{\text{ethanol}} &= (0.2)(10 \text{ kg/s}) = 2 \text{ kg/s} \\ \dot{m}_{\text{water}} &= (0.8)(10 \text{ kg/s}) = 8 \text{ kg/s}\end{aligned}$$

Noting that the molar masses $M_{\text{ethanol}} = 46$ and $M_{\text{water}} = 18$ kg/kmol and that mole numbers $N = m/M$, the mole flow rates become

$$\begin{aligned}\dot{N}_{\text{ethanol}} &= \frac{\dot{m}_{\text{ethanol}}}{M_{\text{ethanol}}} = \frac{2 \text{ kg/s}}{46 \text{ kg/kmol}} = 0.04348 \text{ kmol/s} \\ \dot{N}_{\text{water}} &= \frac{\dot{m}_{\text{water}}}{M_{\text{water}}} = \frac{8 \text{ kg/s}}{18 \text{ kg/kmol}} = 0.44444 \text{ kmol/s}\end{aligned}$$

Note that

$$\frac{\dot{N}_{\text{water}}}{\dot{N}_{\text{ethanol}}} = \frac{0.44444}{0.04348} = 10.222 \text{ kmol H}_2\text{O/kmol C}_2\text{H}_5\text{OH}$$

That is, 10.222 moles of liquid water is present in the solution for each mole of ethanol.

Assuming complete combustion, the combustion equation of $\text{C}_2\text{H}_5\text{OH}(\ell)$ with stoichiometric amount of air is

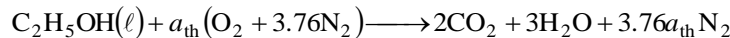

where a_{th} is the stoichiometric coefficient and is determined from the O_2 balance,

$$1 + 2a_{\text{th}} = 4 + 3 \longrightarrow a_{\text{th}} = 3$$

Thus,

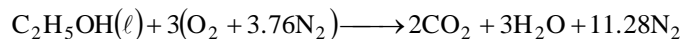

Noting that 10.222 kmol of liquid water accompanies each kmol of ethanol, the actual combustion equation can be written as

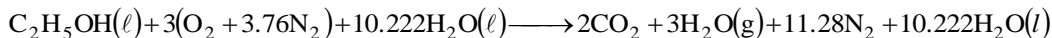

The heat transfer for this combustion process is determined from the steady-flow energy balance equation with $W = 0$,

$$Q = \sum N_P (\bar{h}_f^\circ + \bar{h} - \bar{h}^\circ)_P - \sum N_R (\bar{h}_f^\circ + \bar{h} - \bar{h}^\circ)_R$$

Assuming the air and the combustion products to be ideal gases, we have $h = h(T)$. We assume all the reactants to enter the combustion chamber at the standard reference temperature of 25°C. Furthermore, we assume the products to leave the combustion chamber at 1400 K which is a little over the required temperature of 1100°C. From the tables,

Substance	\bar{h}_f° kJ/kmol	$\bar{h}_{298\text{ K}}$ kJ/kmol	$\bar{h}_{1400\text{ K}}$ kJ/kmol
C ₂ H ₅ OH (ℓ)	-277,690	---	---
CH ₄	-74,850	---	---
O ₂	0	8682	45,648
N ₂	0	8669	43,605
H ₂ O (g)	-241,820	9904	53,351
H ₂ O (ℓ)	-285,830	---	---
CO ₂	-393,520	9364	65,271

Thus,

$$\begin{aligned}
 Q &= (2)(-393,520 + 65,271 - 9364) + (3)(-241,820 + 53,351 - 9904) \\
 &\quad + (11.28)(0 + 43,605 - 8669) - (1)(-277,690) - 0 - 0 \\
 &\quad + (10.222)(-241,820 + 53,351 - 9904) - (10.222)(-285,830) \\
 &= 295,409 \text{ kJ/kmol of C}_2\text{H}_5\text{OH}
 \end{aligned}$$

The positive sign indicates that 295,409 kJ of heat must be supplied to the combustion chamber from another source (such as burning methane) to ensure that the combustion products will leave at the desired temperature of 1400 K. Then the rate of heat transfer required for a mole flow rate of 0.04348 kmol C₂H₅OH/s becomes

$$\dot{Q} = \dot{N}Q = (0.04348 \text{ kmol/s})(295,409 \text{ kJ/kmol}) = 12,844 \text{ kJ/s}$$

Assuming complete combustion, the combustion equation of CH₄(g) with stoichiometric amount of air is

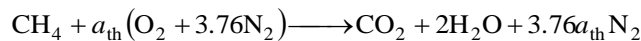

where a_{th} is the stoichiometric coefficient and is determined from the O₂ balance,

Thus,

$$a_{\text{th}} = 1 + 1 \longrightarrow a_{\text{th}} = 2$$

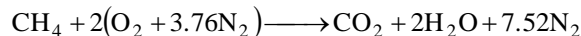

The heat transfer for this combustion process is determined from the steady-flow energy balance $E_{\text{in}} - E_{\text{out}} = \Delta E_{\text{system}}$ equation as shown above under the same assumptions and using the same mini table:

$$\begin{aligned}
 Q &= (1)(-393,520 + 65,271 - 9364) + (2)(-241,820 + 53,351 - 9904) \\
 &\quad + (7.52)(0 + 43,605 - 8669) - (1)(-74,850) - 0 - 0 \\
 &= -396,790 \text{ kJ/kmol of CH}_4
 \end{aligned}$$

That is, 396,790 kJ of heat is supplied to the combustion chamber for each kmol of methane burned. To supply heat at the required rate of 12,844 kJ/s, we must burn methane at a rate of

$$\dot{N}_{\text{CH}_4} = \frac{\dot{Q}}{Q} = \frac{12,844 \text{ kJ/s}}{396,790 \text{ kJ/kmol}} = 0.03237 \text{ kmolCH}_4/\text{s}$$

or,

$$\dot{m}_{\text{CH}_4} = M_{\text{CH}_4} \dot{N}_{\text{CH}_4} = (16 \text{ kg/kmol})(0.03237 \text{ kmolCH}_4/\text{s}) = \mathbf{0.5179 \text{ kg/s}}$$

Therefore, we must supply methane to the combustion chamber at a minimum rate 0.5179 kg/s in order to maintain the temperature of the combustion chamber above 1400 K.



Solutions Manual for
Thermodynamics: An Engineering Approach
8th Edition
Yunus A. Çengel, Michael A. Boles
McGraw-Hill, 2015

Chapter 16

CHEMICAL AND PHASE EQUILIBRIUM

PROPRIETARY AND CONFIDENTIAL

This Manual is the proprietary property of McGraw-Hill Education and protected by copyright and other state and federal laws. By opening and using this Manual the user agrees to the following restrictions, and if the recipient does not agree to these restrictions, the Manual should be promptly returned unopened to McGraw-Hill Education: **This Manual is being provided only to authorized professors and instructors for use in preparing for the classes using the affiliated textbook. No other use or distribution of this Manual is permitted. This Manual may not be sold and may not be distributed to or used by any student or other third party. No part of this Manual may be reproduced, displayed or distributed in any form or by any means, electronic or otherwise, without the prior written permission of McGraw-Hill Education.**

K_p and Equilibrium Composition of Ideal Gases

16-1C They are

$$K_p = \frac{P_C^{v_C} P_D^{v_D}}{P_A^{v_A} P_B^{v_B}}, \quad K_p = e^{-\Delta G^*(T)/R_u T} \quad \text{and} \quad K_p = \frac{N_C^{v_C} N_D^{v_D}}{N_A^{v_A} N_B^{v_B}} \left(\frac{P}{N_{\text{total}}} \right)^{\Delta v}$$

where $\Delta v = v_C + v_D - v_A - v_B$. The first relation is useful in partial pressure calculations, the second in determining the K_p from gibbs functions, and the last one in equilibrium composition calculations.

16-2C (a) The equilibrium constant for the reaction $\text{CO} + \frac{1}{2} \text{O}_2 \Leftrightarrow \text{CO}_2$ can be expressed as

$$K_p = \frac{N_{\text{CO}_2}^{v_{\text{CO}_2}}}{N_{\text{CO}}^{v_{\text{CO}}} N_{\text{O}_2}^{v_{\text{O}_2}}} \left(\frac{P}{N_{\text{total}}} \right)^{(v_{\text{CO}_2} - v_{\text{CO}} - v_{\text{O}_2})}$$

Judging from the values in Table A-28, the K_p value for this reaction decreases as temperature increases. That is, the indicated reaction will be less complete at higher temperatures. Therefore, the number of moles of CO_2 will decrease and the number moles of CO and O_2 will increase as the temperature increases.

(b) The value of the exponent in this case is $1 - 1 - 0.5 = -0.5$, which is negative. Thus as the pressure increases, the term in the brackets will decrease. The value of K_p depends on temperature only, and therefore it will not change with pressure. Then to keep the equation balanced, the number of moles of the products (CO_2) must increase, and the number of moles of the reactants (CO , O_2) must decrease.

16-3C (a) The equilibrium constant for the reaction $\text{N}_2 \Leftrightarrow 2\text{N}$ can be expressed as

$$K_p = \frac{N_{\text{N}}^{v_{\text{N}}}}{N_{\text{N}_2}^{v_{\text{N}_2}}} \left(\frac{P}{N_{\text{total}}} \right)^{(v_{\text{N}} - v_{\text{N}_2})}$$

Judging from the values in Table A-28, the K_p value for this reaction increases as the temperature increases. That is, the indicated reaction will be more complete at higher temperatures. Therefore, the number of moles of N will increase and the number moles of N_2 will decrease as the temperature increases.

(b) The value of the exponent in this case is $2 - 1 = 1$, which is positive. Thus as the pressure increases, the term in the brackets also increases. The value of K_p depends on temperature only, and therefore it will not change with pressure. Then to keep the equation balanced, the number of moles of the products (N) must decrease, and the number of moles of the reactants (N_2) must increase.

16-4C The equilibrium constant for the reaction $\text{CO} + \frac{1}{2} \text{O}_2 \Leftrightarrow \text{CO}_2$ can be expressed as

$$K_p = \frac{N_{\text{CO}_2}^{v_{\text{CO}_2}}}{N_{\text{CO}}^{v_{\text{CO}}} N_{\text{O}_2}^{v_{\text{O}_2}}} \left(\frac{P}{N_{\text{total}}} \right)^{(v_{\text{CO}_2} - v_{\text{CO}} - v_{\text{O}_2})}$$

Adding more N_2 (an inert gas) at constant temperature and pressure will increase N_{total} but will have no direct effect on other terms. Then to keep the equation balanced, the number of moles of the products (CO_2) must increase, and the number of moles of the reactants (CO , O_2) must decrease.

16-5C The values of the equilibrium constants for each dissociation reaction at 3000 K are, from Table A-28,

$$\text{N}_2 \Leftrightarrow 2\text{N} \Leftrightarrow \ln K_p = -22.359$$

$$\text{H}_2 \Leftrightarrow 2\text{H} \Leftrightarrow \ln K_p = -3.685 \quad (\text{greater than } -22.359)$$

Thus H_2 is more likely to dissociate than N_2 .

16-6C (a) This reaction is the reverse of the known H_2O reaction. The equilibrium constant is then

$$1/K_p$$

(b) This reaction is the reverse of the known H_2O reaction at a different pressure. Since pressure has no effect on the equilibrium constant,

$$1/K_p$$

(c) This reaction is the same as the known H_2O reaction multiplied by 3. The equilibrium constant is then

$$K_p^3$$

(d) This is the same as reaction (c) occurring at a different pressure. Since pressure has no effect on the equilibrium constant,

$$K_p^3$$

16-7C (a) K_{p1} , (b) $1/K_{p1}$, (c) K_{p1}^2 , (d) K_{p1} , (e) $1/K_{p1}^3$.

16-8C (a) K_{p1} , (b) $1/K_{p1}$, (c) K_{p1} , (d) K_{p1} , (e) K_{p1}^2 .

16-9C (a) No, because K_p depends on temperature only.

(b) Yes, because the total mixture pressure affects the mixture composition. The equilibrium constant for the reaction $\text{CO} + \frac{1}{2}\text{O}_2 \Leftrightarrow \text{CO}_2$ can be expressed as

$$K_p = \frac{N_{\text{CO}_2}^{v_{\text{CO}_2}}}{N_{\text{CO}}^{v_{\text{CO}}} N_{\text{O}_2}^{v_{\text{O}_2}}} \left(\frac{P}{N_{\text{total}}} \right)^{(v_{\text{CO}_2} - v_{\text{CO}} - v_{\text{O}_2})}$$

The value of the exponent in this case is $1 - 1 - 0.5 = -0.5$, which is negative. Thus as the pressure increases, the term in the brackets will decrease. The value of K_p depends on temperature only, and therefore it will not change with pressure. Then to keep the equation balanced, the number of moles of the products (CO_2) must increase, and the number of moles of the reactants (CO , O_2) must decrease.

16-10 The mole fractions of the constituents of an ideal gas mixture is given. The Gibbs function of the N_2 in this mixture at the given mixture pressure and temperature is to be determined.

Analysis From Tables A-18 and A-26, at 1 atm pressure,

$$\begin{aligned}\bar{g}^*(600 \text{ K}, 1 \text{ atm}) &= \bar{g}_f^0 + \Delta[\bar{h}(T) - T\bar{s}^0(T)] \\ &= 0 + (17,563 - 600 \times 212.066) - (8669 - 298 \times 191.502) \\ &= -61,278 \text{ kJ/kmol}\end{aligned}$$

The partial pressure of N_2 is

$$P_{N_2} = y_{N_2}P = (0.30)(5 \text{ atm}) = 1.5 \text{ atm}$$

The Gibbs function of N_2 at 600 K and 1.5 atm is

$$\begin{aligned}\bar{g}(600 \text{ K}, 1.5 \text{ atm}) &= \bar{g}^*(600 \text{ K}, 1 \text{ atm}) + R_u T \ln P_{N_2} \\ &= -61,278 \text{ kJ/kmol} + (8.314 \text{ kJ/kmol})(600 \text{ K})\ln(1.5 \text{ atm}) \\ &= \mathbf{-59,260 \text{ kJ/kmol}}\end{aligned}$$

30% N_2
30% O_2
40% H_2O
5 atm
600 K

16-11 The temperature at which 0.2 percent of diatomic oxygen dissociates into monatomic oxygen at two pressures is to be determined.

Assumptions 1 The equilibrium composition consists of N_2 and N . **2** The constituents of the mixture are ideal gases.

Analysis (a) The stoichiometric and actual reactions can be written as

Stoichiometric: $N_2 \leftrightarrow 2N$ (thus $\nu_{N_2} = 1$ and $\nu_N = 2$)

Actual: $N_2 \leftrightarrow \underbrace{0.998N_2}_{\text{react.}} + \underbrace{0.004N}_{\text{prod.}}$

The equilibrium constant K_p can be determined from

$$K_p = \frac{N_N^{\nu_N}}{N_{N_2}^{\nu_{N_2}}} \left(\frac{P}{N_{\text{total}}} \right)^{\nu_N - \nu_{N_2}} = \frac{0.004^2}{0.998} \left(\frac{1/101.325}{0.998 + 0.004} \right)^{2-1} = 1.579 \times 10^{-7}$$

and

$$\ln K_p = -15.66$$

From Table A-28, the temperature corresponding to this $\ln K_p$ value is

$$T = \mathbf{3628 \text{ K}}$$

(b) At 10 kPa,

$$K_p = \frac{N_N^{\nu_N}}{N_{N_2}^{\nu_{N_2}}} \left(\frac{P}{N_{\text{total}}} \right)^{\nu_N - \nu_{N_2}} = \frac{0.004^2}{0.998} \left(\frac{10/101.325}{0.998 + 0.004} \right)^{2-1} = 1.579 \times 10^{-6}$$

$$\ln K_p = -13.36$$

From Table A-28, the temperature corresponding to this $\ln K_p$ value is

$$T = \mathbf{3909 \text{ K}}$$

$N_2 \leftrightarrow 2N$
0.2%
1 kPa

16-12 The temperature at which 5 percent of diatomic oxygen dissociates into monatomic oxygen at a specified pressure is to be determined.

Assumptions 1 The equilibrium composition consists of O_2 and O . **2** The constituents of the mixture are ideal gases.

Analysis The stoichiometric and actual reactions can be written as

Stoichiometric: $O_2 \leftrightarrow 2O$ (thus $\nu_{O_2} = 1$ and $\nu_O = 2$)

Actual: $O_2 \leftrightarrow \underbrace{0.95O_2}_{\text{react.}} + \underbrace{0.1O}_{\text{prod.}}$

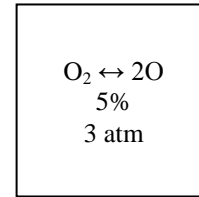

The equilibrium constant K_p can be determined from

$$K_p = \frac{N_O^{\nu_O}}{N_{O_2}^{\nu_{O_2}}} \left(\frac{P}{N_{\text{total}}} \right)^{\nu_O - \nu_{O_2}} = \frac{0.1^2}{0.95} \left(\frac{3}{0.95 + 0.1} \right)^{2-1} = 0.03008$$

From Table A-28, the temperature corresponding to this K_p value is

$$T = \mathbf{3133 \text{ K}}$$

16-13 The temperature at which 5 percent of diatomic oxygen dissociates into monatomic oxygen at a specified pressure is to be determined.

Assumptions 1 The equilibrium composition consists of O_2 and O . **2** The constituents of the mixture are ideal gases.

Analysis The stoichiometric and actual reactions can be written as

Stoichiometric: $O_2 \leftrightarrow 2O$ (thus $\nu_{O_2} = 1$ and $\nu_O = 2$)

Actual: $O_2 \leftrightarrow \underbrace{0.95O_2}_{\text{react.}} + \underbrace{0.1O}_{\text{prod.}}$

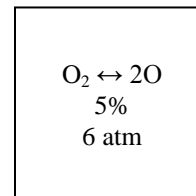

The equilibrium constant K_p can be determined from

$$K_p = \frac{N_O^{\nu_O}}{N_{O_2}^{\nu_{O_2}}} \left(\frac{P}{N_{\text{total}}} \right)^{\nu_O - \nu_{O_2}} = \frac{0.1^2}{0.95} \left(\frac{6}{0.95 + 0.1} \right)^{2-1} = 0.06015$$

From Table A-28, the temperature corresponding to this K_p value is

$$T = \mathbf{3152 \text{ K}}$$

16-14 The equilibrium constant of the reaction $\text{H}_2\text{O} \leftrightarrow 1/2\text{H}_2 + \text{OH}$ is listed in Table A-28 at different temperatures. It is to be verified at a given temperature using Gibbs function data.

Analysis The K_p value of a reaction at a specified temperature can be determined from the Gibbs function data using

$$K_p = e^{-\Delta G^*(T)/R_u T} \quad \text{or} \quad \ln K_p = -\Delta G^*(T) / R_u T$$

where

$$\Delta G^*(T) = \nu_{\text{H}_2} \bar{g}_{\text{H}_2}^*(T) + \nu_{\text{OH}} \bar{g}_{\text{OH}}^*(T) - \nu_{\text{H}_2\text{O}} \bar{g}_{\text{H}_2\text{O}}^*(T)$$

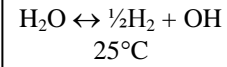

At 298 K,

$$\Delta G^*(T) = 0.5(0) + 1(34,280) - 1(-228,590) = 262,870 \text{ kJ / kmol}$$

Substituting,

$$\ln K_p = -(262,870 \text{ kJ/kmol}) / [(8.314 \text{ kJ/kmol} \cdot \text{K})(298 \text{ K})] = -106.10$$

or

$$K_p = \mathbf{8.34 \times 10^{-47}} \quad (\text{Table A - 28: } \ln K_p = -106.21)$$

16-15 The equilibrium constant of the reaction $\text{H}_2\text{O} \Leftrightarrow \text{H}_2 + \frac{1}{2}\text{O}_2$ is to be determined using Gibbs function.

Analysis (a) The K_p value of a reaction at a specified temperature can be determined from the Gibbs function data using

$$K_p = e^{-\Delta G^*(T)/R_u T} \quad \text{or} \quad \ln K_p = -\Delta G^*(T) / R_u T$$

where

$$\Delta G^*(T) = \nu_{\text{H}_2} \bar{g}_{\text{H}_2}^*(T) + \nu_{\text{O}_2} \bar{g}_{\text{O}_2}^*(T) - \nu_{\text{H}_2\text{O}} \bar{g}_{\text{H}_2\text{O}}^*(T)$$

At 1000 K,

$$\begin{aligned} \Delta G^*(T) &= \nu_{\text{H}_2} \bar{g}_{\text{H}_2}^*(T) + \nu_{\text{O}_2} \bar{g}_{\text{O}_2}^*(T) - \nu_{\text{H}_2\text{O}} \bar{g}_{\text{H}_2\text{O}}^*(T) \\ &= \nu_{\text{H}_2} (\bar{h} - T\bar{s})_{\text{H}_2} + \nu_{\text{O}_2} (\bar{h} - T\bar{s})_{\text{O}_2} - \nu_{\text{H}_2\text{O}} (\bar{h} - T\bar{s})_{\text{H}_2\text{O}} \\ &= \nu_{\text{H}_2} [(\bar{h}_f + \bar{h}_{1000} - \bar{h}_{298}) - T\bar{s}]_{\text{H}_2} \\ &\quad + \nu_{\text{O}_2} [(\bar{h}_f + \bar{h}_{1000} - \bar{h}_{298}) - T\bar{s}]_{\text{O}_2} \\ &\quad - \nu_{\text{H}_2\text{O}} [(\bar{h}_f + \bar{h}_{1000} - \bar{h}_{298}) - T\bar{s}]_{\text{H}_2\text{O}} \\ &= 1 \times (0 + 29,154 - 8468 - 1000 \times 166.114) \\ &\quad + 0.5 \times (0 + 31,389 - 8682 - 1000 \times 243.471) \\ &\quad - 1 \times (-241,820 + 35,882 - 9904 - 1000 \times 232.597) \\ &= 192,629 \text{ kJ/kmol} \end{aligned}$$

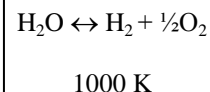

Substituting,

$$\ln K_p = -\frac{192,629 \text{ kJ/kmol}}{(8.314 \text{ kJ/kmol} \cdot \text{K})(1000 \text{ K})} = \mathbf{-23.17}$$

or

$$K_p = \mathbf{8.66 \times 10^{-11}} \quad (\text{Table A - 28: } \ln K_p = -23.16)$$

At 2000 K,

$$\begin{aligned} \Delta G^*(T) &= \nu_{\text{H}_2} \bar{g}_{\text{H}_2}^*(T) + \nu_{\text{O}_2} \bar{g}_{\text{O}_2}^*(T) - \nu_{\text{H}_2\text{O}} \bar{g}_{\text{H}_2\text{O}}^*(T) \\ &= \nu_{\text{H}_2} (\bar{h} - T\bar{s})_{\text{H}_2} + \nu_{\text{O}_2} (\bar{h} - T\bar{s})_{\text{O}_2} - \nu_{\text{H}_2\text{O}} (\bar{h} - T\bar{s})_{\text{H}_2\text{O}} \\ &= \nu_{\text{H}_2} [(\bar{h}_f + \bar{h}_{2000} - \bar{h}_{298}) - T\bar{s}]_{\text{H}_2} \\ &\quad + \nu_{\text{O}_2} [(\bar{h}_f + \bar{h}_{2000} - \bar{h}_{298}) - T\bar{s}]_{\text{O}_2} \\ &\quad - \nu_{\text{H}_2\text{O}} [(\bar{h}_f + \bar{h}_{2000} - \bar{h}_{298}) - T\bar{s}]_{\text{H}_2\text{O}} \\ &= 1 \times (0 + 61,400 - 8468 - 2000 \times 188.297) \\ &\quad + 0.5 \times (0 + 67,881 - 8682 - 2000 \times 268.655) \\ &\quad - 1 \times (-241,820 + 82,593 - 9904 - 2000 \times 264.571) \\ &= 135,556 \text{ kJ/kmol} \end{aligned}$$

Substituting,

$$\ln K_p = -(135,556 \text{ kJ/kmol}) / [(8.314 \text{ kJ/kmol} \cdot \text{K})(2000 \text{ K})] = \mathbf{-8.15}$$

or

$$K_p = \mathbf{2.88 \times 10^{-4}} \quad (\text{Table A - 28: } \ln K_p = -8.15)$$

16-16 The reaction $C + O_2 \rightleftharpoons CO_2$ is considered. The mole fraction of the carbon dioxide produced when this reaction occurs at 1 atm and 3800 K are to be determined.

Assumptions 1 The equilibrium composition consists of CO_2 , C and O_2 . **2** The constituents of the mixture are ideal gases.

Analysis The stoichiometric and actual reactions in this case are

Stoichiometric: $C + O_2 \rightleftharpoons CO_2$ (thus $\nu_C = 1$, $\nu_{O_2} = 1$, and $\nu_{CO_2} = 1$)

Actual: $C + O_2 \longrightarrow \underbrace{x C + y O_2}_{\text{react.}} + \underbrace{z CO_2}_{\text{products}}$

C balance: $1 = x + z \longrightarrow z = 1 - x$

O balance: $2 = 2y + 2z \longrightarrow y = 1 - z = 1 - (1 - x) = x$

Total number of moles: $N_{\text{total}} = x + y + z = 1 + x$

The equilibrium constant relation can be expressed as

$$K_p = \frac{N_{CO_2}^{\nu_{CO_2}}}{N_C^{\nu_C} N_{O_2}^{\nu_{O_2}}} \left(\frac{P}{N_{\text{total}}} \right)^{(\nu_{CO_2} - \nu_C - \nu_{O_2})}$$

From the problem statement at 3800 K, $\ln K_p = -0.461$. Then,

$$K_p = \exp(-0.461) = 0.6307$$

Substituting,

$$0.6307 = \frac{(1-x)}{(x)(x)} \left(\frac{1}{1+x} \right)^{1-1-1}$$

Solving for x ,

$$x = 0.7831$$

Then,

$$y = x = 0.7831$$

$$z = 1 - x = 0.2169$$

Therefore, the equilibrium composition of the mixture at 3800 K and 1 atm is

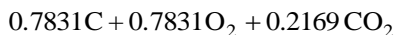

The mole fraction of carbon dioxide is

$$y_{CO_2} = \frac{N_{CO_2}}{N_{\text{total}}} = \frac{0.2169}{1 + 0.7831} = \mathbf{0.1216}$$

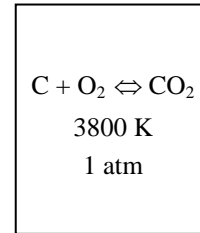

16-17 A gaseous mixture consisting of methane and carbon dioxide is heated. The equilibrium composition (by mole fraction) of the resulting mixture is to be determined.

Assumptions 1 The equilibrium composition consists of CH_4 , C, H_2 , and CO_2 . **2** The constituents of the mixture are ideal gases.

Analysis The stoichiometric and actual reactions in this case are

Stoichiometric: $\text{CH}_4 \leftrightarrow \text{C} + 2\text{H}_2$ (thus $\nu_{\text{CH}_4} = 1$, $\nu_{\text{C}} = 1$, and $\nu_{\text{H}_2} = 2$)

Actual: $0.3\text{CH}_4 + 0.7\text{CO}_2 \longrightarrow \underbrace{x\text{CH}_4}_{\text{react.}} + \underbrace{y\text{C} + z\text{H}_2}_{\text{products}} + \underbrace{0.7\text{CO}_2}_{\text{inert}}$

C balance: $0.3 = x + y \longrightarrow y = 0.3 - x$

H balance: $1.2 = 4x + 2z \longrightarrow z = 0.6 - 2x$

Total number of moles: $N_{\text{total}} = x + y + z + 1 = 1.6 - 2x$

The equilibrium constant relation can be expressed as

$$K_p = \frac{N_{\text{CH}_4}^{\nu_{\text{CH}_4}}}{N_{\text{C}}^{\nu_{\text{C}}} N_{\text{H}_2}^{\nu_{\text{H}_2}}} \left(\frac{P}{N_{\text{total}}} \right)^{\nu_{\text{CH}_4} - \nu_{\text{C}} - \nu_{\text{H}_2}}$$

From the problem statement at 1200 K, $\ln K_p = 4.147$. Then,

$$K_p = \exp(4.147) = 63.244$$

For the reverse reaction that we consider,

$$K_p = 1/63.244 = 0.01581$$

Substituting,

$$0.01581 = \frac{x}{(0.3 - x)(0.6 - 2x)^2} \left(\frac{1}{1.6 - 2x} \right)^{1-1-2}$$

Solving for x ,

$$x = 0.0006637$$

Then,

$$y = 0.3 - x = 0.2993$$

$$z = 0.6 - 2x = 0.5987$$

Therefore, the equilibrium composition of the mixture at 1200 K and 1 atm is

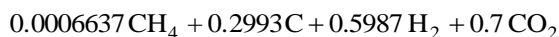

The mole fractions are

$$y_{\text{CH}_4} = \frac{N_{\text{CH}_4}}{N_{\text{total}}} = \frac{0.0006637}{1.6 - 2 \times 0.0006637} = \frac{0.0006637}{1.599} = \mathbf{0.000415}$$

$$y_{\text{C}} = \frac{N_{\text{C}}}{N_{\text{total}}} = \frac{0.2993}{1.599} = \mathbf{0.1872}$$

$$y_{\text{H}_2} = \frac{N_{\text{H}_2}}{N_{\text{total}}} = \frac{0.5987}{1.599} = \mathbf{0.3745}$$

$$y_{\text{CO}_2} = \frac{N_{\text{CO}_2}}{N_{\text{total}}} = \frac{0.7}{1.599} = \mathbf{0.4379}$$

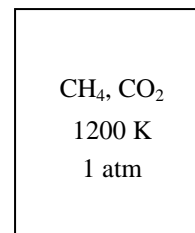

16-18 The dissociation reaction $\text{CO}_2 \Leftrightarrow \text{CO} + \text{O}$ is considered. The composition of the products at given pressure and temperature is to be determined.

Assumptions 1 The equilibrium composition consists of CO_2 , CO , and O . **2** The constituents of the mixture are ideal gases.

Analysis For the stoichiometric reaction $\text{CO}_2 \Leftrightarrow \text{CO} + \frac{1}{2}\text{O}_2$, from Table A-28, at 2500 K

$$\ln K_p = -3.331$$

For the oxygen dissociation reaction $0.5\text{O}_2 \Leftrightarrow \text{O}$, from Table A-28, at 2500 K,

$$\ln K_p = -8.509 / 2 = -4.255$$

For the desired stoichiometric reaction $\text{CO}_2 \Leftrightarrow \text{CO} + \text{O}$ (thus $\nu_{\text{CO}_2} = 1$, $\nu_{\text{CO}} = 1$ and $\nu_{\text{O}} = 1$),

$$\ln K_p = -3.331 - 4.255 = -7.586$$

and

$$K_p = \exp(-7.586) = 0.0005075$$

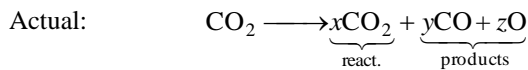

C balance: $1 = x + y \longrightarrow y = 1 - x$

O balance: $2 = 2x + y + z \longrightarrow z = 1 - x$

Total number of moles: $N_{\text{total}} = x + y + z = 2 - x$

The equilibrium constant relation can be expressed as

$$K_p = \frac{N_{\text{CO}}^{\nu_{\text{CO}}} N_{\text{O}}^{\nu_{\text{O}}}}{N_{\text{CO}_2}^{\nu_{\text{CO}_2}}} \left(\frac{P}{N_{\text{total}}} \right)^{\nu_{\text{CO}} + \nu_{\text{O}} - \nu_{\text{CO}_2}}$$

Substituting,

$$0.0005075 = \frac{(1-x)(1-x)}{x} \left(\frac{1}{2-x} \right)^{1+1-1}$$

Solving for x ,

$$x = 0.9775$$

Then,

$$y = 1 - x = 0.0225$$

$$z = 1 - x = 0.0225$$

Therefore, the equilibrium composition of the mixture at 2500 K and 1 atm is

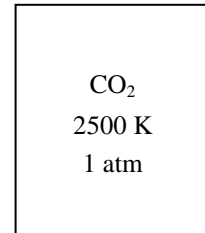
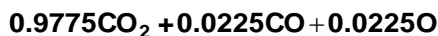

16-19 The reaction $\text{N}_2 + \text{O}_2 \rightleftharpoons 2\text{NO}$ is considered. The equilibrium mole fraction of NO at 1800 K and 1 atm is to be determined.

Assumptions 1 The equilibrium composition consists of N_2 , O_2 , and NO. **2** The constituents of the mixture are ideal gases.

Analysis The stoichiometric and actual reactions in this case are

Stoichiometric: $\text{N}_2 + \text{O}_2 \rightleftharpoons 2\text{NO}$ (thus $\nu_{\text{N}_2} = 1$, $\nu_{\text{O}_2} = 1$, and $\nu_{\text{NO}} = 2$)

Actual: $\text{N}_2 + \text{O}_2 \longrightarrow \underbrace{x\text{N}_2 + y\text{O}_2}_{\text{react.}} + \underbrace{z\text{NO}}_{\text{products}}$

N balance: $2 = 2x + z \longrightarrow z = 2 - 2x$

O balance: $2 = 2y + z \longrightarrow y = x$

Total number of moles: $N_{\text{total}} = x + y + z = 2$

The equilibrium constant relation can be expressed as

$$K_p = \frac{N_{\text{NO}}^{\nu_{\text{NO}}}}{N_{\text{N}_2}^{\nu_{\text{N}_2}} N_{\text{O}_2}^{\nu_{\text{O}_2}}} \left(\frac{P}{N_{\text{total}}} \right)^{(\nu_{\text{NO}} - \nu_{\text{N}_2} - \nu_{\text{O}_2})}$$

From Table A-28, at 1800 K, $\ln K_p = -4.536$. Since the stoichiometric reaction being considered is double this reaction,

$$K_p = \exp(-2 \times 4.536) = 1.148 \times 10^{-4}$$

Substituting,

$$1.148 \times 10^{-4} = \frac{(2 - 2x)^2}{x^2} \left(\frac{1}{2} \right)^{2-1-1}$$

Solving for x ,

$$x = 0.9947$$

Then,

$$y = x = 0.9947$$

$$z = 2 - 2x = 0.010659$$

Therefore, the equilibrium composition of the mixture at 1800 K and 1 atm is

$$0.9947 \text{N}_2 + 0.9947 \text{O}_2 + 0.010659 \text{NO}$$

The mole fraction of NO is then

$$y_{\text{NO}} = \frac{N_{\text{NO}}}{N_{\text{total}}} = \frac{0.010659}{2} = \mathbf{0.00533}$$

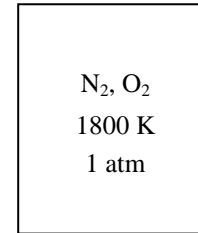

16-20E The equilibrium constant of the reaction $\text{H}_2 + 1/2\text{O}_2 \leftrightarrow \text{H}_2\text{O}$ is listed in Table A-28 at different temperatures. The data are to be verified at two temperatures using Gibbs function data.

Analysis (a) The K_p value of a reaction at a specified temperature can be determined from the Gibbs function data using

$$K_p = e^{-\Delta G^*(T)/R_u T} \quad \text{or} \quad \ln K_p = -\Delta G^*(T) / R_u T$$

where

$$\Delta G^*(T) = \nu_{\text{H}_2\text{O}} \bar{g}_{\text{H}_2\text{O}}^*(T) - \nu_{\text{H}_2} \bar{g}_{\text{H}_2}^*(T) - \nu_{\text{O}_2} \bar{g}_{\text{O}_2}^*(T)$$

At 537 R,

$$\Delta G^*(T) = 1(-98,350) - 1(0) - 0.5(0) = -98,350 \text{ Btu / lbmol}$$

Substituting,

$$\ln K_p = -(-98,350 \text{ Btu / lbmol}) / [(1.986 \text{ Btu / lbmol} \cdot \text{R})(537 \text{ R})] = 92.22$$

or

$$K_p = \mathbf{1.12 \times 10^{40}} \quad (\text{Table A - 28: } \ln K_p = 92.21)$$

(b) At 3240 R,

$$\begin{aligned} \Delta G^*(T) &= \nu_{\text{H}_2\text{O}} \bar{g}_{\text{H}_2\text{O}}^*(T) - \nu_{\text{H}_2} \bar{g}_{\text{H}_2}^*(T) - \nu_{\text{O}_2} \bar{g}_{\text{O}_2}^*(T) \\ &= \nu_{\text{H}_2\text{O}} (\bar{h} - T\bar{s})_{\text{H}_2\text{O}} - \nu_{\text{H}_2} (\bar{h} - T\bar{s})_{\text{H}_2} - \nu_{\text{O}_2} (\bar{h} - T\bar{s})_{\text{O}_2} \\ &= \nu_{\text{H}_2\text{O}} [(\bar{h}_f + \bar{h}_{4320} - \bar{h}_{537}) - T\bar{s}]_{\text{H}_2\text{O}} \\ &\quad - \nu_{\text{H}_2} [(\bar{h}_f + \bar{h}_{4320} - \bar{h}_{298}) - T\bar{s}]_{\text{H}_2} \\ &\quad - \nu_{\text{O}_2} [(\bar{h}_f + \bar{h}_{4320} - \bar{h}_{298}) - T\bar{s}]_{\text{O}_2} \\ &= 1 \times (-104,040 + 31,205 - 4258 - 3240 \times 61.948) \\ &\quad - 1 \times (0 + 23,485 - 3640.3 - 3240 \times 44.125) \\ &\quad - 0.5 \times (0 + 25,972 - 3725.1 - 3240 \times 63.224) \\ &= -63,385 \text{ Btu/lbmol} \end{aligned}$$

Substituting,

$$\ln K_p = -\frac{-63,385 \text{ Btu/lbmol}}{(1.986 \text{ Btu/lbmolR})(3240 \text{ R})} = 9.851$$

or

$$K_p = \mathbf{1.90 \times 10^4} \quad (\text{Table A - 28: } \ln K_p = 9.826)$$

Discussion Solving this problem using EES with the built-in ideal gas properties give $K_p = 1.04 \times 10^{40}$ for part (a) and $K_p = 18,692$ for part (b).

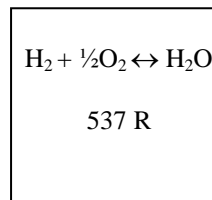

16-21 The equilibrium constant of the reaction $\text{CO} + 1/2\text{O}_2 \leftrightarrow \text{CO}_2$ at 298 K and 2000 K are to be determined, and compared with the values listed in Table A-28.

Analysis (a) The K_p value of a reaction at a specified temperature can be determined from the Gibbs function data using

$$K_p = e^{-\Delta G^*(T)/R_u T} \quad \text{or} \quad \ln K_p = -\Delta G^*(T) / R_u T$$

where

$$\Delta G^*(T) = \nu_{\text{CO}_2} \bar{g}_{\text{CO}_2}^*(T) - \nu_{\text{CO}} \bar{g}_{\text{CO}}^*(T) - \nu_{\text{O}_2} \bar{g}_{\text{O}_2}^*(T)$$

At 298 K,

$$\Delta G^*(T) = 1(-394,360) - 1(-137,150) - 0.5(0) = -257,210 \text{ kJ/kmol}$$

where the Gibbs functions are obtained from Table A-26. Substituting,

$$\ln K_p = -\frac{(-257,210 \text{ kJ/kmol})}{(8.314 \text{ kJ/kmol} \cdot \text{K})(298 \text{ K})} = \mathbf{103.81}$$

From Table A-28: $\ln K_p = \mathbf{103.76}$

(b) At 2000 K,

$$\begin{aligned} \Delta G^*(T) &= \nu_{\text{CO}_2} \bar{g}_{\text{CO}_2}^*(T) - \nu_{\text{CO}} \bar{g}_{\text{CO}}^*(T) - \nu_{\text{O}_2} \bar{g}_{\text{O}_2}^*(T) \\ &= \nu_{\text{CO}_2} (\bar{h} - T\bar{s})_{\text{CO}_2} - \nu_{\text{CO}} (\bar{h} - T\bar{s})_{\text{CO}} - \nu_{\text{O}_2} (\bar{h} - T\bar{s})_{\text{O}_2} \\ &= 1[(-302,128) - (2000)(309.00)] - 1[(-53,826) - (2000)(258.48)] - 0.5[(59,193) - (2000)(268.53)] \\ &= -110,409 \text{ kJ/kmol} \end{aligned}$$

The enthalpies at 2000 K and entropies at 2000 K and 101.3 kPa (1 atm) are obtained from EES. Substituting,

$$\ln K_p = -\frac{(-110,409 \text{ kJ/kmol})}{(8.314 \text{ kJ/kmol} \cdot \text{K})(2000 \text{ K})} = \mathbf{6.64}$$

From Table A-28:

$$\ln K_p = \mathbf{6.635}$$

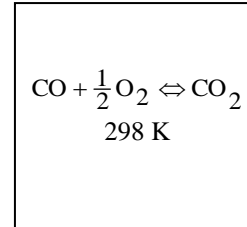

16-22  The effect of varying the percent excess air during the steady-flow combustion of hydrogen is to be studied.

Analysis The combustion equation of hydrogen with stoichiometric amount of air is

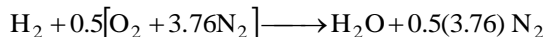

For the incomplete combustion with 100% excess air, the combustion equation is

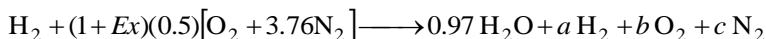

The coefficients are to be determined from the mass balances

Hydrogen balance: $2 = 0.97 \times 2 + a \times 2 \longrightarrow a = 0.03$

Oxygen balance: $(1 + Ex) \times 0.5 \times 2 = 0.97 + b \times 2$

Nitrogen balance: $(1 + Ex) \times 0.5 \times 3.76 \times 2 = c \times 2$

Solving the above equations, we find the coefficients ($Ex = 1$, $a = 0.03$, $b = 0.515$, $c = 3.76$) and write the balanced reaction equation as

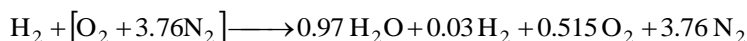

Total moles of products at equilibrium are

$$N_{\text{tot}} = 0.97 + 0.03 + 0.515 + 3.76 = 5.275$$

The assumed equilibrium reaction is

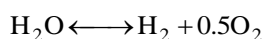

The K_p value of a reaction at a specified temperature can be determined from the Gibbs function data using

$$K_p = e^{-\Delta G^*(T)/R_u T} \quad \text{or} \quad \ln K_p = -\Delta G^*(T) / R_u T$$

where

$$\Delta G^*(T) = \nu_{\text{H}_2} \bar{g}_{\text{H}_2}^*(T_{\text{prod}}) + \nu_{\text{O}_2} \bar{g}_{\text{O}_2}^*(T_{\text{prod}}) - \nu_{\text{H}_2\text{O}} \bar{g}_{\text{H}_2\text{O}}^*(T_{\text{prod}})$$

and the Gibbs functions are defined as

$$\bar{g}_{\text{H}_2}^*(T_{\text{prod}}) = (\bar{h} - T_{\text{prod}} \bar{s})_{\text{H}_2}$$

$$\bar{g}_{\text{O}_2}^*(T_{\text{prod}}) = (\bar{h} - T_{\text{prod}} \bar{s})_{\text{O}_2}$$

$$\bar{g}_{\text{H}_2\text{O}}^*(T_{\text{prod}}) = (\bar{h} - T_{\text{prod}} \bar{s})_{\text{H}_2\text{O}}$$

The equilibrium constant is also given by

$$K_p = \left(\frac{P}{N_{\text{tot}}} \right)^{1+0.5-1} \frac{ab^{0.5}}{0.97^1} = \left(\frac{1}{5.275} \right)^{0.5} \frac{(0.03)(0.515)^{0.5}}{0.97} = 0.009664$$

and $\ln K_p = \ln(0.009664) = -4.647$

The corresponding temperature is obtained solving the above equations using EES to be

$$T_{\text{prod}} = \mathbf{2600\text{K}}$$

This is the temperature at which 97 percent of H_2 will burn into H_2O . The copy of EES solution is given next.

"Input Data from parametric table:"

{PercentEx = 10}

Ex = PercentEx/100 "EX = % Excess air/100"

P_prod = 101.3 "[kPa]"

PROPRIETARY MATERIAL. © 2015 McGraw-Hill Education. Limited distribution permitted only to teachers and educators for course preparation. If you are a student using this Manual, you are using it without permission.

$$R_u = 8.314 \text{ [kJ/kmol-K]}$$

"The combustion equation of H₂ with stoichiometric amount of air is

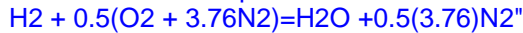

"For the incomplete combustion with 100% excess air, the combustion equation is

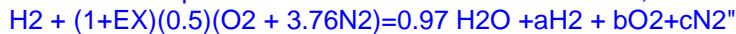

"Specie balance equations give the values of a, b, and c."

"H, hydrogen"

$$2 = 0.97 \cdot 2 + a \cdot 2$$

"O, oxygen"

$$(1+\text{EX}) \cdot 0.5 \cdot 2 = 0.97 + b \cdot 2$$

"N, nitrogen"

$$(1+\text{EX}) \cdot 0.5 \cdot 3.76 \cdot 2 = c \cdot 2$$

$$N_{\text{tot}} = 0.97 + a + b + c \text{ "Total kilomoles of products at equilibrium"}$$

"The assumed equilibrium reaction is

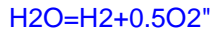

"The following equations provide the specific Gibbs function ($g = h - Ts$) for each H₂ component in the product gases as a function of its temperature, T_{prod} , at 1 atm pressure, 101.3 kPa"

$$g_{\text{H}_2\text{O}} = \text{Enthalpy}(\text{H}_2\text{O}, T = T_{\text{prod}}) - T_{\text{prod}} \cdot \text{Entropy}(\text{H}_2\text{O}, T = T_{\text{prod}}, P = 101.3)$$

$$g_{\text{H}_2} = \text{Enthalpy}(\text{H}_2, T = T_{\text{prod}}) - T_{\text{prod}} \cdot \text{Entropy}(\text{H}_2, T = T_{\text{prod}}, P = 101.3)$$

$$g_{\text{O}_2} = \text{Enthalpy}(\text{O}_2, T = T_{\text{prod}}) - T_{\text{prod}} \cdot \text{Entropy}(\text{O}_2, T = T_{\text{prod}}, P = 101.3)$$

"The standard-state Gibbs function is"

$$\Delta G = 1 \cdot g_{\text{H}_2} + 0.5 \cdot g_{\text{O}_2} - 1 \cdot g_{\text{H}_2\text{O}}$$

"The equilibrium constant is given by Eq. 15-14."

$$K_P = \exp(-\Delta G / (R_u \cdot T_{\text{prod}}))$$

$$P = P_{\text{prod}} / 101.3 \text{ "atm"}$$

"The equilibrium constant is also given by Eq. 15-15."

$$K_P = (P / N_{\text{tot}})^{(1+0.5-1)} \cdot (a^1 \cdot b^{0.5}) / (0.97^1)"$$

$$\sqrt{P / N_{\text{tot}}} \cdot a \cdot \sqrt{b} = K_P \cdot 0.97$$

$$\ln K_p = \ln(k_P)$$

$\ln K_p$	PercentEx [%]	T_{prod} [K]
-5.414	10	2440
-5.165	20	2490
-5.019	30	2520
-4.918	40	2542
-4.844	50	2557
-4.786	60	2570
-4.739	70	2580
-4.7	80	2589
-4.667	90	2596
-4.639	100	2602

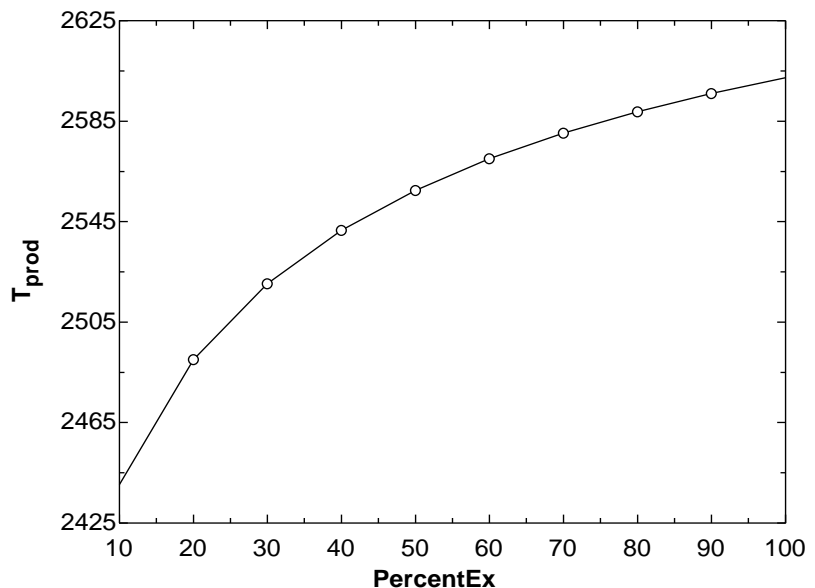

16-23 The equilibrium constant of the reaction $\text{CH}_4 + 2\text{O}_2 \leftrightarrow \text{CO}_2 + 2\text{H}_2\text{O}$ at 25°C is to be determined.

Analysis The K_p value of a reaction at a specified temperature can be determined from the Gibbs function data using

$$K_p = e^{-\Delta G^*(T)/R_u T} \quad \text{or} \quad \ln K_p = -\Delta G^*(T) / R_u T$$

where

$$\Delta G^*(T) = \nu_{\text{CO}_2} \bar{g}_{\text{CO}_2}^*(T) + \nu_{\text{H}_2\text{O}} \bar{g}_{\text{H}_2\text{O}}^*(T) - \nu_{\text{CH}_4} \bar{g}_{\text{CH}_4}^*(T) - \nu_{\text{O}_2} \bar{g}_{\text{O}_2}^*(T)$$

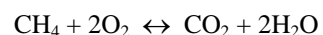

25°C

At 25°C ,

$$\Delta G^*(T) = 1(-394,360) + 2(-228,590) - 1(-50,790) - 2(0) = -800,750 \text{ kJ / kmol}$$

Substituting,

$$\ln K_p = -(-800,750 \text{ kJ/kmol}) / [(8.314 \text{ kJ/kmol} \cdot \text{K})(298 \text{ K})] = 323.04$$

or $K_p = \mathbf{1.96 \times 10^{140}}$

16-24 The equilibrium constant of the reaction $\text{CO}_2 \leftrightarrow \text{CO} + 1/2\text{O}_2$ is listed in Table A-28 at different temperatures. It is to be verified using Gibbs function data.

Analysis (a) The K_p value of a reaction at a specified temperature can be determined from the Gibbs function data using

$$K_p = e^{-\Delta G^*(T)/R_u T} \quad \text{or} \quad \ln K_p = -\Delta G^*(T) / R_u T$$

where $\Delta G^*(T) = \nu_{\text{CO}} \bar{g}_{\text{CO}}^*(T) + \nu_{\text{O}_2} \bar{g}_{\text{O}_2}^*(T) - \nu_{\text{CO}_2} \bar{g}_{\text{CO}_2}^*(T)$

At 298 K,

$$\Delta G^*(T) = 1(-137,150) + 0.5(0) - 1(-394,360) = 257,210 \text{ kJ/kmol}$$

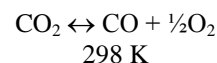

Substituting,

$$\ln K_p = -(257,210 \text{ kJ/kmol}) / [(8.314 \text{ kJ/kmol} \cdot \text{K})(298 \text{ K})] = -103.81$$

or $K_p = \mathbf{8.24 \times 10^{-46}}$ (Table A - 28: $\ln K_p = -103.76$)

(b) At 1800 K,

$$\begin{aligned} \Delta G^*(T) &= \nu_{\text{CO}} \bar{g}_{\text{CO}}^*(T) + \nu_{\text{O}_2} \bar{g}_{\text{O}_2}^*(T) - \nu_{\text{CO}_2} \bar{g}_{\text{CO}_2}^*(T) \\ &= \nu_{\text{CO}} (\bar{h} - T\bar{s})_{\text{CO}} + \nu_{\text{O}_2} (\bar{h} - T\bar{s})_{\text{O}_2} - \nu_{\text{CO}_2} (\bar{h} - T\bar{s})_{\text{CO}_2} \\ &= \nu_{\text{CO}} [(\bar{h}_f + \bar{h}_{1800} - \bar{h}_{298}) - T\bar{s}]_{\text{CO}} \\ &\quad + \nu_{\text{O}_2} [(\bar{h}_f + \bar{h}_{1800} - \bar{h}_{298}) - T\bar{s}]_{\text{O}_2} \\ &\quad - \nu_{\text{CO}_2} [(\bar{h}_f + \bar{h}_{1800} - \bar{h}_{298}) - T\bar{s}]_{\text{CO}_2} \\ &= 1 \times (-110,530 + 58,191 - 8669 - 1800 \times 254.797) \\ &\quad + 0.5 \times (0 + 60,371 - 8682 - 1800 \times 264.701) \\ &\quad - 1 \times (-393,520 + 88,806 - 9364 - 1800 \times 302.884) \\ &= 127,240.2 \text{ kJ/kmol} \end{aligned}$$

Substituting, $\ln K_p = -(127,240.2 \text{ kJ/kmol}) / [(8.314 \text{ kJ/kmol} \cdot \text{K})(1800 \text{ K})] = -8.502$

or $K_p = \mathbf{2.03 \times 10^{-4}}$ (Table A - 28: $\ln K_p = -8.497$)

16-25  Carbon monoxide is burned with 100 percent excess air. The temperature at which 97 percent of CO burn to CO₂ is to be determined.

Assumptions 1 The equilibrium composition consists of CO₂, CO, O₂, and N₂. **2** The constituents of the mixture are ideal gases.

Analysis Assuming N₂ to remain as an inert gas, the stoichiometric and actual reactions can be written as

Stoichiometric: $\text{CO} + \frac{1}{2}\text{O}_2 \leftrightarrow \text{CO}_2$ (thus $\nu_{\text{CO}_2} = 1$, $\nu_{\text{CO}} = 1$, and $\nu_{\text{O}_2} = \frac{1}{2}$)

Actual: $\text{CO} + 1(\text{O}_2 + 3.76\text{N}_2) \longrightarrow \underbrace{0.97\text{CO}_2}_{\text{product}} + \underbrace{0.03\text{CO} + 0.515\text{O}_2}_{\text{reactants}} + \underbrace{3.76\text{N}_2}_{\text{inert}}$

The equilibrium constant K_p can be determined from

$$K_p = \frac{N_{\text{CO}_2}^{\nu_{\text{CO}_2}}}{N_{\text{CO}}^{\nu_{\text{CO}}} N_{\text{O}_2}^{\nu_{\text{O}_2}}} \left(\frac{P}{N_{\text{total}}} \right)^{(\nu_{\text{CO}_2} - \nu_{\text{CO}} - \nu_{\text{O}_2})}$$

$$= \frac{0.97}{0.03 \times 0.515^{0.5}} \left(\frac{1}{0.97 + 0.03 + 0.515 + 3.76} \right)^{1-1.5}$$

$$= 103.5$$

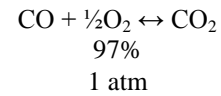

and

$$\ln K_p = 4.639$$

From Table A-28, the temperature corresponding to this K_p value is $T = 2276 \text{ K}$



16-26 Problem 16-25 is reconsidered. The effect of varying the percent excess air during the steady-flow process from 0 to 200 percent on the temperature at which 97 percent of CO burn into CO₂ is to be studied.

Analysis The problem is solved using EES, and the solution is given below.

"To solve this problem, we need to give EES a guess value for T_{prop} other than the default value of 1. Set the guess value of T_{prod} to 1000 K by selecting Variable Information in the Options menu. Then press F2 or click the Calculator icon."

"Input Data from the diagram window:"

{PercentEx = 100}

Ex = PercentEx/100 "EX = % Excess air/100"

P_{prod} = 101.3 [kPa]

R_u = 8.314 [kJ/kmol-K]

f = 0.97

"The combustion equation of CO with stoichiometric amount of air is
 $\text{CO} + 0.5(\text{O}_2 + 3.76\text{N}_2) = \text{CO}_2 + 0.5(3.76)\text{N}_2$ "

"For the incomplete combustion with 100% excess air, the combustion equation is
 $\text{CO} + (1+\text{EX})(0.5)(\text{O}_2 + 3.76\text{N}_2) = 0.97 \text{CO}_2 + a\text{CO} + b\text{O}_2 + c\text{N}_2$ "

"Specie balance equations give the values of a, b, and c."

"C, Carbon"

$1 = f + a$

"O, oxygen"

$1 + (1+\text{EX}) \cdot 0.5 \cdot 2 = f \cdot 2 + a \cdot 1 + b \cdot 2$

"N, nitrogen"

$(1+\text{EX}) \cdot 0.5 \cdot 3.76 \cdot 2 = c \cdot 2$

$N_{\text{tot}} = f + a + b + c$ "Total kilomoles of products at equilibrium"

"The assumed equilibrium reaction is $\text{CO}_2 = \text{CO} + 0.5\text{O}_2$ "

"The following equations provide the specific Gibbs function ($g = h - Ts$) for each component in the product gases as a function of its temperature, T_{prod}, at 1 atm pressure, 101.3 kPa"

$g_{\text{CO}_2} = \text{Enthalpy}(\text{CO}_2, T = T_{\text{prod}}) - T_{\text{prod}} \cdot \text{Entropy}(\text{CO}_2, T = T_{\text{prod}}, P = 101.3)$

$g_{\text{CO}} = \text{Enthalpy}(\text{CO}, T = T_{\text{prod}}) - T_{\text{prod}} \cdot \text{Entropy}(\text{CO}, T = T_{\text{prod}}, P = 101.3)$

$g_{\text{O}_2} = \text{Enthalpy}(\text{O}_2, T = T_{\text{prod}}) - T_{\text{prod}} \cdot \text{Entropy}(\text{O}_2, T = T_{\text{prod}}, P = 101.3)$

"The standard-state Gibbs function is"

$\text{DELTA}G = 1 \cdot g_{\text{CO}} + 0.5 \cdot g_{\text{O}_2} - 1 \cdot g_{\text{CO}_2}$

"The equilibrium constant is given by Eq. 15-14."

$K_P = \exp(-\text{DELTA}G / (R_u \cdot T_{\text{prod}}))$

$P = P_{\text{prod}} / 101.3 \text{ "atm"}$

"The equilibrium constant is also given by Eq. 15-15."

$K_P = (P/N_{\text{tot}})^{1+0.5-1} \cdot (a^1 \cdot b^{0.5}) / (0.97^1)$

$\sqrt{P/N_{\text{tot}}} \cdot a \cdot \sqrt{b} = K_P \cdot f$

$\ln K_p = \ln(k_P)$

"Compare the value of lnK_p calculated by EES with the value of lnK_p from table A-28 in the text."

PercentEx [%]	T _{prod} [K]
0	2065
20	2193
40	2230
60	2250
80	2263
100	2272
120	2279
140	2285
160	2289
180	2293
200	2296

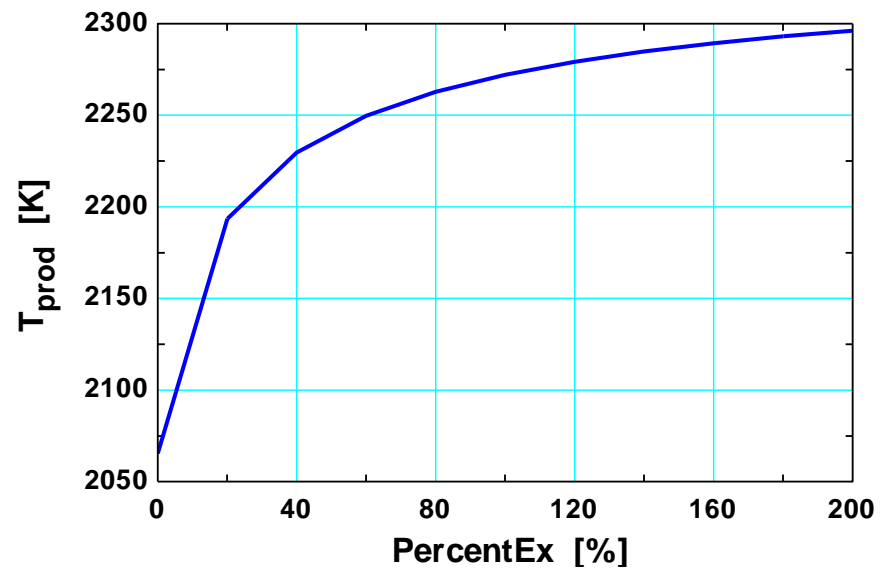

16-27E Carbon monoxide is burned with 100 percent excess air. The temperature at which 97 percent of CO burn to CO₂ is to be determined.

Assumptions 1 The equilibrium composition consists of CO₂, CO, O₂, and N₂. **2** The constituents of the mixture are ideal gases.

Analysis Assuming N₂ to remain as an inert gas, the stoichiometric and actual reactions can be written as

Stoichiometric: $\text{CO} + \frac{1}{2}\text{O}_2 \leftrightarrow \text{CO}_2$ (thus $\nu_{\text{CO}_2} = 1$, $\nu_{\text{CO}} = 1$, and $\nu_{\text{O}_2} = \frac{1}{2}$)

Actual: $\text{CO} + 1(\text{O}_2 + 3.76\text{N}_2) \longrightarrow \underbrace{0.97\text{CO}_2}_{\text{product}} + \underbrace{0.03\text{CO} + 0.515\text{O}_2}_{\text{reactants}} + \underbrace{3.76\text{N}_2}_{\text{inert}}$

The equilibrium constant K_p can be determined from

$$K_p = \frac{N_{\text{CO}_2}^{\nu_{\text{CO}_2}}}{N_{\text{CO}}^{\nu_{\text{CO}}} N_{\text{O}_2}^{\nu_{\text{O}_2}}} \left(\frac{P}{N_{\text{total}}} \right)^{(\nu_{\text{CO}_2} - \nu_{\text{CO}} - \nu_{\text{O}_2})}$$

$$= \frac{0.97}{0.03 \times 0.515^{0.5}} \left(\frac{1}{0.97 + 0.03 + 0.515 + 3.76} \right)^{1-1.5}$$

$$= 103.5$$

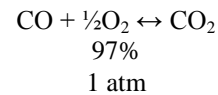

and

$$\ln K_p = 4.639$$

From Table A-28, the temperature corresponding to this K_p value is $T = 2276 \text{ K} = \mathbf{4097 \text{ R}}$

16-28 Air is heated to a high temperature. The equilibrium composition at that temperature is to be determined.

Assumptions 1 The equilibrium composition consists of N_2 , O_2 , and NO . **2** The constituents of the mixture are ideal gases.

Analysis The stoichiometric and actual reactions in this case are

Stoichiometric: $\frac{1}{2} N_2 + \frac{1}{2} O_2 \Leftrightarrow NO$ (thus $\nu_{NO} = 1$, $\nu_{N_2} = \frac{1}{2}$, and $\nu_{O_2} = \frac{1}{2}$)

Actual: $3.76 N_2 + O_2 \longrightarrow \underbrace{x NO}_{\text{prod.}} + \underbrace{y N_2 + z O_2}_{\text{reactants}}$

N balance: $7.52 = x + 2y$ or $y = 3.76 - 0.5x$

O balance: $2 = x + 2z$ or $z = 1 - 0.5x$

Total number of moles: $N_{\text{total}} = x + y + z = x + 4.76 - x = 4.76$

The equilibrium constant relation can be expressed as

$$K_p = \frac{N_{NO}^{\nu_{NO}}}{N_{N_2}^{\nu_{N_2}} N_{O_2}^{\nu_{O_2}}} \left(\frac{P}{N_{\text{total}}} \right)^{(\nu_{NO} - \nu_{N_2} - \nu_{O_2})}$$

From Table A-28, $\ln K_p = -3.931$ at 2000 K. Thus $K_p = 0.01962$. Substituting,

$$0.01962 = \frac{x}{(3.76 - 0.5x)^{0.5} (1 - 0.5x)^{0.5}} \left(\frac{2}{4.76} \right)^{1-1}$$

Solving for x ,

$$x = 0.0376$$

Then,

$$y = 3.76 - 0.5x = 3.7412$$

$$z = 1 - 0.5x = 0.9812$$

Therefore, the equilibrium composition of the mixture at 2000 K and 2 atm is

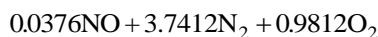

The equilibrium constant for the reactions $O_2 \Leftrightarrow 2O$ ($\ln K_p = -14.622$) and $N_2 \Leftrightarrow 2N$ ($\ln K_p = -41.645$) are much smaller than that of the specified reaction ($\ln K_p = -3.931$). Therefore, it is realistic to assume that no monatomic oxygen or nitrogen will be present in the equilibrium mixture. Also the equilibrium composition in this case is independent of pressure since $\Delta\nu = 1 - 0.5 - 0.5 = 0$.

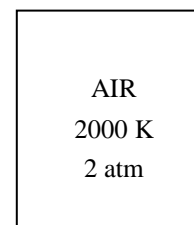

16-29 Hydrogen is heated to a high temperature at a constant pressure. The percentage of H_2 that will dissociate into H is to be determined.

Assumptions 1 The equilibrium composition consists of H_2 and H. **2** The constituents of the mixture are ideal gases.

Analysis The stoichiometric and actual reactions can be written as

Stoichiometric: $H_2 \leftrightarrow 2H$ (thus $\nu_{H_2} = 1$ and $\nu_H = 2$)

Actual: $H_2 \longrightarrow \underbrace{xH_2}_{\text{react.}} + \underbrace{yH}_{\text{prod.}}$

H balance: $2 = 2x + y$ or $y = 2 - 2x$

Total number of moles: $N_{\text{total}} = x + y = x + 2 - 2x = 2 - x$

The equilibrium constant relation can be expressed as

$$K_p = \frac{N_H^{\nu_H}}{N_{H_2}^{\nu_{H_2}}} \left(\frac{P}{N_{\text{total}}} \right)^{\nu_H - \nu_{H_2}}$$

From Table A-28, $\ln K_p = 0.202$ at 3800 K. Thus $K_p = 1.224$. Substituting,

$$1.224 = \frac{(2 - 2x)^2}{x} \left(\frac{5}{2 - x} \right)^{2-1}$$

Solving for x ,

$$x = 0.7599$$

Thus the percentage of H_2 which dissociates to H at 3200 K and 5 atm is

$$1 - 0.7599 = 0.240 \quad \text{or} \quad \mathbf{24.0\%}$$

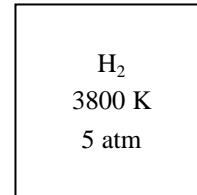

16-30 Carbon dioxide is heated to a high temperature at a constant pressure. The percentage of CO_2 that will dissociate into CO and O_2 is to be determined.

Assumptions 1 The equilibrium composition consists of CO_2 , CO , and O_2 . **2** The constituents of the mixture are ideal gases.

Analysis The stoichiometric and actual reactions in this case are

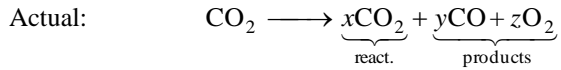
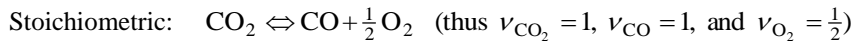

C balance: $1 = x + y \longrightarrow y = 1 - x$

O balance: $2 = 2x + y + 2z \longrightarrow z = 0.5 - 0.5x$

Total number of moles: $N_{\text{total}} = x + y + z = 1.5 - 0.5x$

The equilibrium constant relation can be expressed as

$$K_p = \frac{N_{\text{CO}}^{\nu_{\text{CO}}} N_{\text{O}_2}^{\nu_{\text{O}_2}}}{N_{\text{CO}_2}^{\nu_{\text{CO}_2}}} \left(\frac{P}{N_{\text{total}}} \right)^{(\nu_{\text{CO}} + \nu_{\text{O}_2} - \nu_{\text{CO}_2})}$$

From Table A-28, $\ln K_p = -3.860$ at 2400 K. Thus $K_p = 0.02107$ Substituting,

$$0.02107 = \frac{(1-x)(0.5-0.5x)^{1/2}}{x} \left(\frac{3}{1.5-0.5x} \right)^{1.5-1}$$

Solving for x ,

$$x = 0.936$$

Thus the percentage of CO_2 which dissociates into CO and O_2 is

$$1 - 0.936 = 0.064 \text{ or } \mathbf{6.4\%}$$

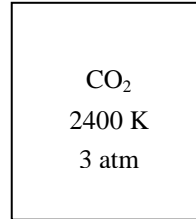

16-31 A mixture of CO and O₂ is heated to a high temperature at a constant pressure. The equilibrium composition is to be determined.

Assumptions 1 The equilibrium composition consists of CO₂, CO, and O₂. **2** The constituents of the mixture are ideal gases.

Analysis The stoichiometric and actual reactions in this case are

Stoichiometric: $\text{CO}_2 \Leftrightarrow \text{CO} + \frac{1}{2}\text{O}_2$ (thus $\nu_{\text{CO}_2} = 1$, $\nu_{\text{CO}} = 1$, and $\nu_{\text{O}_2} = \frac{1}{2}$)

Actual: $\text{CO} + 3\text{O}_2 \longrightarrow \underbrace{x\text{CO}_2}_{\text{react.}} + \underbrace{y\text{CO} + z\text{O}_2}_{\text{products}}$

C balance: $1 = x + y \longrightarrow y = 1 - x$

O balance: $7 = 2x + y + 2z$ or $z = 3 - 0.5x$

Total number of moles: $N_{\text{total}} = x + y + z = 4 - 0.5x$

The equilibrium constant relation can be expressed as

$$K_p = \frac{N_{\text{CO}_2}^{\nu_{\text{CO}_2}}}{N_{\text{CO}}^{\nu_{\text{CO}}} N_{\text{O}_2}^{\nu_{\text{O}_2}}} \left(\frac{P}{N_{\text{total}}} \right)^{(\nu_{\text{CO}_2} - \nu_{\text{CO}} - \nu_{\text{O}_2})}$$

From Table A-28, $\ln K_p = 5.120$ at 2200 K. Thus $K_p = 167.34$. Substituting,

$$167.34 = \frac{x}{(1-x)(3-0.5x)^{0.5}} \left(\frac{2}{4-0.5x} \right)^{1-1.5}$$

Solving for x ,

$$x = 0.995$$

Then,

$$y = 1 - x = 0.005$$

$$z = 3 - 0.5x = 2.5025$$

Therefore, the equilibrium composition of the mixture at 2200 K and 2 atm is



1 CO
3 O ₂
2200 K
2 atm

16-32 A mixture of N_2 , O_2 , and Ar is heated to a high temperature at a constant pressure. The equilibrium composition is to be determined.

Assumptions 1 The equilibrium composition consists of N_2 , O_2 , Ar, and NO. **2** The constituents of the mixture are ideal gases.

Analysis The stoichiometric and actual reactions in this case are

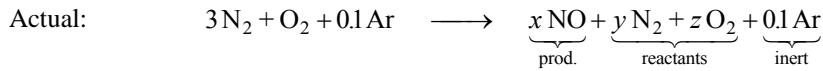
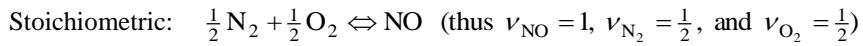

3 N_2
1 O_2
0.1 Ar
2400 K
10 atm

N balance: $6 = x + 2y \longrightarrow y = 3 - 0.5x$

O balance: $2 = x + 2z \longrightarrow z = 1 - 0.5x$

Total number of moles: $N_{\text{total}} = x + y + z + 0.1 = 4.1$

The equilibrium constant relation becomes,

$$K_p = \frac{N_{NO}^{\nu_{NO}}}{N_{N_2}^{\nu_{N_2}} N_{O_2}^{\nu_{O_2}}} \left(\frac{P}{N_{\text{total}}} \right)^{(\nu_{NO} - \nu_{N_2} - \nu_{O_2})} = \frac{x}{y^{0.5} z^{0.5}} \left(\frac{P}{N_{\text{total}}} \right)^{1-0.5-0.5}$$

From Table A-28, $\ln K_p = -3.019$ at 2400 K. Thus $K_p = 0.04885$. Substituting,

$$0.04885 = \frac{x}{(3 - 0.5x)^{0.5} (1 - 0.5x)^{0.5}} \times 1$$

Solving for x ,

$$x = 0.0823$$

Then,

$$y = 3 - 0.5x = 2.9589$$

$$z = 1 - 0.5x = 0.9589$$

Therefore, the equilibrium composition of the mixture at 2400 K and 10 atm is

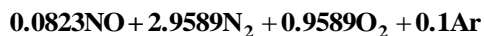

16-33 The mole fraction of sodium that ionizes according to the reaction $\text{Na} \leftrightarrow \text{Na}^+ + \text{e}^-$ at 2000 K and 0.8 atm is to be determined.

Assumptions All components behave as ideal gases.

Analysis The stoichiometric and actual reactions can be written as

Stoichiometric: $\text{Na} \leftrightarrow \text{Na}^+ + \text{e}^-$ (thus $\nu_{\text{Na}} = 1$, $\nu_{\text{Na}^+} = 1$ and $\nu_{\text{e}^-} = 1$)

Actual: $\text{Na} \longrightarrow \underbrace{x\text{Na}}_{\text{react.}} + \underbrace{y\text{Na}^+ + y\text{e}^-}_{\text{products}}$

Na balance: $1 = x + y$ or $y = 1 - x$

Total number of moles: $N_{\text{total}} = x + 2y = 2 - x$

The equilibrium constant relation becomes,

$$K_p = \frac{N_{\text{Na}^+}^{\nu_{\text{Na}^+}} N_{\text{e}^-}^{\nu_{\text{e}^-}}}{N_{\text{Na}}^{\nu_{\text{Na}}}} \left(\frac{P}{N_{\text{total}}} \right)^{(\nu_{\text{Na}^+} + \nu_{\text{e}^-} - \nu_{\text{Na}})} = \frac{y^2}{x} \left(\frac{P}{N_{\text{total}}} \right)^{1+1-1}$$

Substituting,

$$0.668 = \frac{(1-x)^2}{x} \left(\frac{0.8}{2-x} \right)$$

Solving for x ,

$$x = 0.3254$$

Thus the fraction of Na which dissociates into Na^+ and e^- is

$$1 - 0.3254 = 0.6746 \text{ or } \mathbf{67.5\%}$$

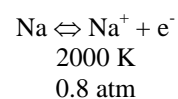

16-34E A steady-flow combustion chamber is supplied with CO and O₂. The equilibrium composition of product gases and the rate of heat transfer from the combustion chamber are to be determined.

Assumptions 1 The equilibrium composition consists of CO₂, CO, and O₂. **2** The constituents of the mixture are ideal gases.

Analysis (a) We first need to calculate the amount of oxygen used per lbmol of CO before we can write the combustion equation,

$$\nu_{\text{CO}} = \frac{RT}{P} = \frac{(0.3831 \text{ psia} \cdot \text{ft}^3 / \text{lbm} \cdot \text{R})(560 \text{ R})}{16 \text{ psia}} = 13.41 \text{ ft}^3 / \text{lbm}$$

$$\dot{m}_{\text{CO}} = \frac{\dot{V}_{\text{CO}}}{\nu_{\text{CO}}} = \frac{12.5 \text{ ft}^3 / \text{min}}{13.41 \text{ ft}^3 / \text{lbm}} = 0.932 \text{ lbm} / \text{min}$$

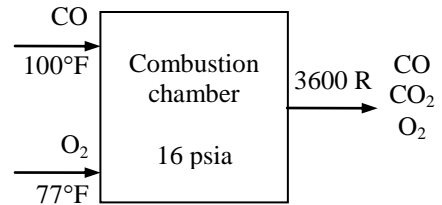

Then the molar air-fuel ratio becomes (it is actually O₂-fuel ratio)

$$\overline{\text{AF}} = \frac{N_{\text{O}_2}}{N_{\text{fuel}}} = \frac{\dot{m}_{\text{O}_2} / M_{\text{O}_2}}{\dot{m}_{\text{fuel}} / M_{\text{fuel}}} = \frac{(0.7 \text{ lbm} / \text{min}) / (32 \text{ lbm} / \text{lbmol})}{(0.932 \text{ lbm} / \text{min}) / (28 \text{ lbm} / \text{lbmol})} = 0.657 \text{ lbmol O}_2 / \text{lbmol fuel}$$

Then the combustion equation can be written as

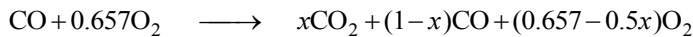

The equilibrium equation among CO₂, CO, and O₂ can be expressed as

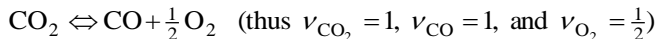

and

$$K_p = \frac{N_{\text{CO}}^{\nu_{\text{CO}}} N_{\text{O}_2}^{\nu_{\text{O}_2}}}{N_{\text{CO}_2}^{\nu_{\text{CO}_2}}} \left(\frac{P}{N_{\text{total}}} \right)^{(\nu_{\text{CO}} + \nu_{\text{O}_2} - \nu_{\text{CO}_2})}$$

where

$$N_{\text{total}} = x + (1-x) + (0.657 - 0.5x) = 1.657 - 0.5x$$

$$P = 16 / 14.7 = 1.088 \text{ atm}$$

From Table A-28, $\ln K_p = -6.635$ at $T = 3600 \text{ R} = 2000 \text{ K}$. Thus $K_p = 1.314 \times 10^{-3}$. Substituting,

$$1.314 \times 10^{-3} = \frac{(1-x)(0.657 - 0.5x)^{0.5}}{x} \left(\frac{1.088}{1.657 - 0.5x} \right)^{1.5-1}$$

Solving for x ,

$$x = 0.9966$$

Then the combustion equation and the equilibrium composition can be expressed as



and



(b) The heat transfer for this combustion process is determined from the steady-flow energy balance $E_{\text{in}} - E_{\text{out}} = \Delta E_{\text{system}}$ on the combustion chamber with $W = 0$,

$$-Q_{\text{out}} = \sum N_P (\bar{h}_f^\circ + \bar{h} - \bar{h}^\circ)_P - \sum N_R (\bar{h}_f^\circ + \bar{h} - \bar{h}^\circ)_R$$

Assuming the air and the combustion products to be ideal gases, we have $h = h(T)$. From the tables,

Substance	\bar{h}_f° Btu/lbmol	$\bar{h}_{537\text{R}}$ Btu/lbmol	$\bar{h}_{560\text{R}}$ Btu/lbmol	$\bar{h}_{3600\text{R}}$ Btu/lbmol
CO	-47,540	3725.1	3889.5	28,127
O ₂	0	3725.1	---	29,174
CO ₂	-169,300	4027.5	---	43,411

Substituting,

$$\begin{aligned}
 -\dot{Q}_{\text{out}} &= 0.9966(-169,300 + 43,411 - 4027.5) \\
 &\quad + 0.0034(-47,540 + 28,127 - 3725.1) \\
 &\quad + 0.1587(0 + 29,174 - 3725.1) \\
 &\quad - 1(-47,540 + 3889.5 - 3725.1) - 0 \\
 &= -78,139 \text{ Btu / lbmol of CO}
 \end{aligned}$$

or $\dot{Q}_{\text{out}} = 78,139 \text{ Btu / lbm of CO}$

The mass flow rate of CO can be expressed in terms of the mole numbers as

$$\dot{N} = \frac{\dot{m}}{M} = \frac{0.932 \text{ lbm / min}}{28 \text{ lbm / lbmol}} = 0.0333 \text{ lbmol / min}$$

Thus the rate of heat transfer is

$$\dot{Q}_{\text{out}} = \dot{N} \times Q_{\text{out}} = (0.0333 \text{ lbmol / min})(78,139 \text{ Btu / lbmol}) = \mathbf{2602 \text{ Btu / min}}$$

16-35 Liquid propane enters a combustion chamber. The equilibrium composition of product gases and the rate of heat transfer from the combustion chamber are to be determined.

Assumptions 1 The equilibrium composition consists of CO_2 , H_2O , CO , N_2 , and O_2 . **2** The constituents of the mixture are ideal gases.

Analysis (a) Considering 1 kmol of C_3H_8 , the stoichiometric combustion equation can be written as

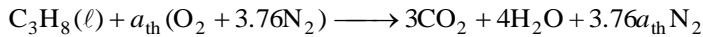

where a_{th} is the stoichiometric coefficient and is determined from the O_2 balance,

$$2.5a_{\text{th}} = 3 + 2 + 1.5a_{\text{th}} \longrightarrow a_{\text{th}} = 5$$

Then the actual combustion equation with 150% excess air and some CO in the products can be written as

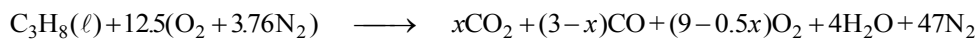

After combustion, there will be no C_3H_8 present in the combustion chamber, and H_2O will act like an inert gas. The equilibrium equation among CO_2 , CO , and O_2 can be expressed as



and

$$K_p = \frac{N_{\text{CO}}^{\nu_{\text{CO}}} N_{\text{O}_2}^{\nu_{\text{O}_2}}}{N_{\text{CO}_2}^{\nu_{\text{CO}_2}}} \left(\frac{P}{N_{\text{total}}} \right)^{(\nu_{\text{CO}} + \nu_{\text{O}_2} - \nu_{\text{CO}_2})}$$

where

$$N_{\text{total}} = x + (3-x) + (9-0.5x) + 4 + 47 = 63 - 0.5x$$

From Table A-28, $\ln K_p = -17.871$ at 1200 K. Thus $K_p = 1.73 \times 10^{-8}$. Substituting,

$$1.73 \times 10^{-8} = \frac{(3-x)(9-0.5x)^{0.5}}{x} \left(\frac{2}{63-0.5x} \right)^{1.5-1}$$

Solving for x ,

$$x = 2.9999999 \cong 3.0$$

Therefore, the amount CO in the product gases is negligible, and it can be disregarded with no loss in accuracy. Then the combustion equation and the equilibrium composition can be expressed as

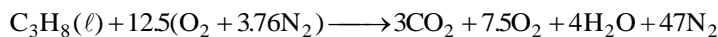

and

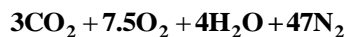

(b) The heat transfer for this combustion process is determined from the steady-flow energy balance $E_{\text{in}} - E_{\text{out}} = \Delta E_{\text{system}}$ on the combustion chamber with $W = 0$,

$$-Q_{\text{out}} = \sum N_P (\bar{h}_f^\circ + \bar{h} - \bar{h}^\circ)_P - \sum N_R (\bar{h}_f^\circ + \bar{h} - \bar{h}^\circ)_R$$

Assuming the air and the combustion products to be ideal gases, we have $h = h(T)$. From the tables, (The \bar{h}_f° of liquid propane is obtained by adding the h_{fg} at 25°C to \bar{h}_f° of gaseous propane).

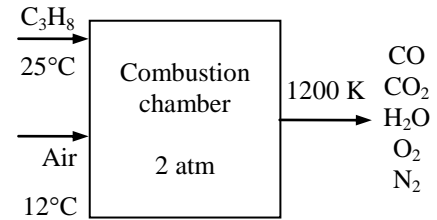

Substance	\bar{h}_f° kJ/kmol	$\bar{h}_{285\text{ K}}$ kJ/kmol	$\bar{h}_{298\text{ K}}$ kJ/kmol	$\bar{h}_{1200\text{ K}}$ kJ/kmol
$\text{C}_3\text{H}_8 (\ell)$	-118,910	---	---	---
O_2	0	8696.5	8682	38,447
N_2	0	8286.5	8669	36,777
$\text{H}_2\text{O} (g)$	-241,820	---	9904	44,380
CO_2	-393,520	---	9364	53,848

Substituting,

$$\begin{aligned}
 -Q_{\text{out}} &= 3(-393,520 + 53,848 - 9364) + 4(-241,820 + 44,380 - 9904) \\
 &\quad + 7.5(0 + 38,447 - 8682) + 47(0 + 36,777 - 8669) \\
 &\quad - 1(-118,910 + h_{298} - h_{298}) - 12.5(0 + 8296.5 - 8682) \\
 &\quad - 47(0 + 8186.5 - 8669) \\
 &= -185,764 \text{ kJ / kmol of } \text{C}_3\text{H}_8
 \end{aligned}$$

or

$$Q_{\text{out}} = 185,764 \text{ kJ / kmol of } \text{C}_3\text{H}_8$$

The mass flow rate of C_3H_8 can be expressed in terms of the mole numbers as

$$\dot{N} = \frac{\dot{m}}{M} = \frac{1.2 \text{ kg / min}}{44 \text{ kg / kmol}} = 0.02727 \text{ kmol / min}$$

Thus the rate of heat transfer is

$$\dot{Q}_{\text{out}} = \dot{N} \times Q_{\text{out}} = (0.02727 \text{ kmol/min})(185,746 \text{ kJ/kmol}) = \mathbf{5066 \text{ kJ/min}}$$

The equilibrium constant for the reaction $\frac{1}{2} \text{N}_2 + \frac{1}{2} \text{O}_2 \leftrightarrow \text{NO}$ is $\ln K_p = -7.569$, which is very small. This indicates that the amount of NO formed during this process will be very small, and can be disregarded.



16-36 Problem 16-35 is reconsidered. It is to be investigated if it is realistic to disregard the presence of NO in the product gases.

Analysis The problem is solved using EES, and the solution is given below.

"To solve this problem, the Gibbs function of the product gases is minimized. Click on the Min/Max icon."

For this problem at 1200 K the moles of CO are 0.000 and moles of NO are 0.000, thus we can disregard both the CO and NO. However, try some product temperatures above 1286 K and observe the sign change on the Q_out and the amount of CO and NO present as the product temperature increases."

"The reaction of C₃H₈(liq) with excess air can be written:



The coefficients A_{th} and EX are the theoretical oxygen and the percent excess air on a decimal basis. Coefficients a, b, c, d, e, and f are found by minimizing the Gibbs Free Energy at a total pressure of the product gases P_{Prod} and the product temperature T_{Prod}.

The equilibrium solution can be found by applying the Law of Mass Action or by minimizing the Gibbs function. In this problem, the Gibbs function is directly minimized using the optimization capabilities built into EES.

To run this program, click on the Min/Max icon. There are six compounds present in the products subject to four specie balances, so there are two degrees of freedom. Minimize the Gibbs function of the product gases with respect to two molar quantities such as coefficients b and f. The equilibrium mole numbers a, b, c, d, e, and f will be determined and displayed in the Solution window."

```
PercentEx = 150 [%]
Ex = PercentEx/100 "EX = % Excess air/100"
P_prod = 2*P_atm
T_Prod = 1200 [K]
m_dot_fuel = 0.5 [kg/s]
Fuel$ = 'C3H8'
T_air = 12+273 "[K]"
T_fuel = 25+273 "[K]"
P_atm = 101.325 [kPa]
R_u = 8.314 [kJ/kmol-K]
```

"Theoretical combustion of C₃H₈ with oxygen:

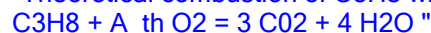

$$2 \cdot \text{A}_{\text{th}} = 3 \cdot 2 + 4 \cdot 1$$

"Balance the reaction for 1 kmol of C₃H₈"



$$b_{\text{max}} = 3$$

$$f_{\text{max}} = (1+\text{Ex}) \cdot \text{A}_{\text{th}} \cdot 3.76 \cdot 2$$

$$e_{\text{guess}} = \text{Ex} \cdot \text{A}_{\text{th}}$$

$$1 \cdot 3 = a \cdot 1 + b \cdot 1 \text{ "Carbon balance"}$$

$$1 \cdot 8 = c \cdot 2$$

"Hydrogen balance"

$$(1+\text{Ex}) \cdot \text{A}_{\text{th}} \cdot 2 = a \cdot 2 + b \cdot 1 + c \cdot 1 + e \cdot 2 + f \cdot 1 \text{ "Oxygen balance"}$$

$$(1+\text{Ex}) \cdot \text{A}_{\text{th}} \cdot 3.76 \cdot 2 = d \cdot 2 + f \cdot 1 \text{ "Nitrogen balance"}$$

"Total moles and mole fractions"

$$N_{\text{Total}} = a + b + c + d + e + f$$

$$y_{\text{CO}_2} = a/N_{\text{Total}}; y_{\text{CO}} = b/N_{\text{Total}}; y_{\text{H}_2\text{O}} = c/N_{\text{Total}}; y_{\text{N}_2} = d/N_{\text{Total}}; y_{\text{O}_2} = e/N_{\text{Total}}; y_{\text{NO}} = f/N_{\text{Total}}$$

"The following equations provide the specific Gibbs function for each component as a function of its molar amount"

$$\begin{aligned} g_{\text{CO}_2} &= \text{Enthalpy}(\text{CO}_2, T=T_{\text{Prod}}) - T_{\text{Prod}} * \text{Entropy}(\text{CO}_2, T=T_{\text{Prod}}, P=P_{\text{Prod}} * y_{\text{CO}_2}) \\ g_{\text{CO}} &= \text{Enthalpy}(\text{CO}, T=T_{\text{Prod}}) - T_{\text{Prod}} * \text{Entropy}(\text{CO}, T=T_{\text{Prod}}, P=P_{\text{Prod}} * y_{\text{CO}}) \\ g_{\text{H}_2\text{O}} &= \text{Enthalpy}(\text{H}_2\text{O}, T=T_{\text{Prod}}) - T_{\text{Prod}} * \text{Entropy}(\text{H}_2\text{O}, T=T_{\text{Prod}}, P=P_{\text{Prod}} * y_{\text{H}_2\text{O}}) \\ g_{\text{N}_2} &= \text{Enthalpy}(\text{N}_2, T=T_{\text{Prod}}) - T_{\text{Prod}} * \text{Entropy}(\text{N}_2, T=T_{\text{Prod}}, P=P_{\text{Prod}} * y_{\text{N}_2}) \\ g_{\text{O}_2} &= \text{Enthalpy}(\text{O}_2, T=T_{\text{Prod}}) - T_{\text{Prod}} * \text{Entropy}(\text{O}_2, T=T_{\text{Prod}}, P=P_{\text{Prod}} * y_{\text{O}_2}) \\ g_{\text{NO}} &= \text{Enthalpy}(\text{NO}, T=T_{\text{Prod}}) - T_{\text{Prod}} * \text{Entropy}(\text{NO}, T=T_{\text{Prod}}, P=P_{\text{Prod}} * y_{\text{NO}}) \end{aligned}$$

"The extensive Gibbs function is the sum of the products of the specific Gibbs function and the molar amount of each substance"

$$\text{Gibbs} = a * g_{\text{CO}_2} + b * g_{\text{CO}} + c * g_{\text{H}_2\text{O}} + d * g_{\text{N}_2} + e * g_{\text{O}_2} + f * g_{\text{NO}}$$

"For the energy balance, we adjust the value of the enthalpy of gaseous propane given by EES:"

$$h_{\text{fg_fuel}} = 15060 \text{ [kJ/kmol]} \text{ "Table A.27"}$$

$$h_{\text{fuel}} = \text{enthalpy}(\text{Fuel}\$, T=T_{\text{fuel}}) - h_{\text{fg_fuel}}$$

"Energy balance for the combustion process:"

$$\text{"C}_3\text{H}_8(\text{l}) + (1+\text{Ex})\text{A}_{\text{th}}(\text{O}_2 + 3.76\text{N}_2) = a \text{CO}_2 + b \text{CO} + c \text{H}_2\text{O} + d \text{N}_2 + e \text{O}_2 + f \text{NO}"$$

$$\text{HR} = \text{Q}_{\text{out}} + \text{HP}$$

$$\text{HR} = h_{\text{fuel}} + (1+\text{Ex}) * \text{A}_{\text{th}} * (\text{enthalpy}(\text{O}_2, T=T_{\text{air}}) + 3.76 * \text{enthalpy}(\text{N}_2, T=T_{\text{air}}))$$

$$\text{HP} = a * \text{enthalpy}(\text{CO}_2, T=T_{\text{prod}}) + b * \text{enthalpy}(\text{CO}, T=T_{\text{prod}}) + c * \text{enthalpy}(\text{H}_2\text{O}, T=T_{\text{prod}}) + d * \text{enthalpy}(\text{N}_2, T=T_{\text{prod}}) + e * \text{enthalpy}(\text{O}_2, T=T_{\text{prod}}) + f * \text{enthalpy}(\text{NO}, T=T_{\text{prod}})$$

"The heat transfer rate is:"

$$\text{Q}_{\text{dot_out}} = \text{Q}_{\text{out}} / \text{molarmass}(\text{Fuel}\$) * m_{\text{dot_fuel}} \text{ [kW]}$$

SOLUTION

a=3.000 [kmol]	g_CO2=-707231 [kJ/kmol]	Q_dot_out=2140 [kW]
A_th=5	g_H2O=-515974 [kJ/kmol]	Q_out=188732 [kJ/kmol_fuel]
b=0.000 [kmol]	g_N2=-248486 [kJ/kmol]	R_u=8.314 [kJ/kmol-K]
b_max=3	g_NO=-342270 [kJ/kmol]	T_air=285 [K]
c=4.000 [kmol]	g_O2=-284065 [kJ/kmol]	T_fuel=298 [K]
d=47.000 [kmol]	HP=-330516.747 [kJ/kmol]	T_Prod=1200.00 [K]
e=7.500 [kmol]	HR=-141784.529 [kJ/kmol]	y_CO=1.626E-15
Ex=1.5	h_fg_fuel=15060 [kJ/kmol]	y_CO2=0.04878
e_guess=7.5	h_fuel=-118918 [kJ/kmol]	y_H2O=0.06504
f=0.000 [kmol]	m_dot_fuel=0.5 [kg/s]	y_N2=0.7642
Fuel\$='C3H8'	N_Total=61.5 [kmol/kmol_fuel]	y_NO=7.857E-08
f_max=94	PercentEx=150 [%]	y_O2=0.122
Gibbs=-17994897 [kJ]	P_atm=101.3 [kPa]	
g_CO=-703496 [kJ/kmol]	P_prod=202.7 [kPa]	

16-37 Oxygen is heated during a steady-flow process. The rate of heat supply needed during this process is to be determined for two cases.

Assumptions 1 The equilibrium composition consists of O_2 and O . **2** All components behave as ideal gases.

Analysis (a) Assuming some O_2 dissociates into O , the dissociation equation can be written as

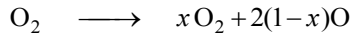

The equilibrium equation among O_2 and O can be expressed as

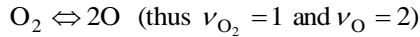

Assuming ideal gas behavior for all components, the equilibrium constant relation can be expressed as

$$K_p = \frac{N_O^{\nu_O}}{N_{O_2}^{\nu_{O_2}}} \left(\frac{P}{N_{\text{total}}} \right)^{\nu_O - \nu_{O_2}}$$

where $N_{\text{total}} = x + 2(1-x) = 2-x$

From Table A-28, $\ln K_p = -4.357$ at 3000 K. Thus $K_p = 0.01282$. Substituting,

$$0.01282 = \frac{(2-2x)^2}{x} \left(\frac{1}{2-x} \right)^{2-1}$$

Solving for x gives

$$x = 0.943$$

Then the dissociation equation becomes

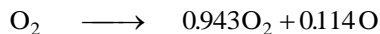

The heat transfer for this combustion process is determined from the steady-flow energy balance $E_{\text{in}} - E_{\text{out}} = \Delta E_{\text{system}}$ on the combustion chamber with $W = 0$,

$$Q_{\text{in}} = \sum N_P (\bar{h}_f^\circ + \bar{h} - \bar{h}^\circ)_P - \sum N_R (\bar{h}_f^\circ + \bar{h} - \bar{h}^\circ)_R$$

Assuming the O_2 and O to be ideal gases, we have $h = h(T)$. From the tables,

Substance	\bar{h}_f° kJ/kmol	$\bar{h}_{298\text{ K}}$ kJ/kmol	$\bar{h}_{3000\text{ K}}$ kJ/kmol
O	249,190	6852	63,425
O_2	0	8682	106,780

Substituting,

$$Q_{\text{in}} = 0.943(0 + 106,780 - 8682) + 0.114(249,190 + 63,425 - 6852) - 0 = 127,363 \text{ kJ / kmol } O_2$$

The mass flow rate of O_2 can be expressed in terms of the mole numbers as

$$\dot{N} = \frac{\dot{m}}{M} = \frac{0.5 \text{ kg/min}}{32 \text{ kg/kmol}} = 0.01563 \text{ kmol/min}$$

Thus the rate of heat transfer is

$$\dot{Q}_{\text{in}} = \dot{N} \times Q_{\text{in}} = (0.01563 \text{ kmol/min})(127,363 \text{ kJ/kmol}) = \mathbf{1990 \text{ kJ/min}}$$

(b) If no O_2 dissociates into O , then the process involves no chemical reactions and the heat transfer can be determined from the steady-flow energy balance for nonreacting systems to be

$$\dot{Q}_{\text{in}} = \dot{m}(h_2 - h_1) = \dot{N}(\bar{h}_2 - \bar{h}_1) = (0.01563 \text{ kmol/min})(106,780 - 8682) \text{ kJ/kmol} = \mathbf{1533 \text{ kJ/min}}$$

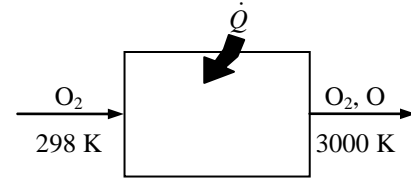

16-38 The equilibrium constant, K_p is to be estimated at 2500 K for the reaction $\text{CO} + \text{H}_2\text{O} = \text{CO}_2 + \text{H}_2$.

Analysis (a) The K_p value of a reaction at a specified temperature can be determined from the Gibbs function data using

$$K_p = e^{-\Delta G^*(T)/R_u T} \quad \text{or} \quad \ln K_p = -\Delta G^*(T)/R_u T$$

where

$$\Delta G^*(T) = \nu_{\text{CO}_2} \bar{g}_{\text{CO}_2}^*(T) + \nu_{\text{H}_2} \bar{g}_{\text{H}_2}^*(T) - \nu_{\text{CO}} \bar{g}_{\text{CO}}^*(T) - \nu_{\text{H}_2\text{O}} \bar{g}_{\text{H}_2\text{O}}^*(T)$$

At 2500 K,

$$\begin{aligned} \Delta G^*(T) &= \nu_{\text{CO}_2} \bar{g}_{\text{CO}_2}^*(T) + \nu_{\text{H}_2} \bar{g}_{\text{H}_2}^*(T) - \nu_{\text{CO}} \bar{g}_{\text{CO}}^*(T) - \nu_{\text{H}_2\text{O}} \bar{g}_{\text{H}_2\text{O}}^*(T) \\ &= \nu_{\text{CO}_2} (\bar{h} - T\bar{s})_{\text{CO}_2} + \nu_{\text{H}_2} (\bar{h} - T\bar{s})_{\text{H}_2} - \nu_{\text{CO}} (\bar{h} - T\bar{s})_{\text{CO}} - \nu_{\text{H}_2\text{O}} (\bar{h} - T\bar{s})_{\text{H}_2\text{O}} \\ &= 1[-393,520 + 131,290 - 9364] - (2500)(322.808) \\ &\quad + 1[(0 + 78,960 - 8468) - (2500)(196.125)] \\ &\quad - 1[-110,530 + 83,692 - 8669] - (2500)(266.755) \\ &\quad - 1[-241,820 + 108,868 - 9904] - (2500)(276.286) \\ &= 37,531 \text{ kJ/kmol} \end{aligned}$$

Substituting,

$$\ln K_p = -\frac{37,531 \text{ kJ/kmol}}{(8.314 \text{ kJ/kmol} \cdot \text{K})(2500 \text{ K})} = -1.8057 \longrightarrow K_p = \mathbf{0.1644}$$

The equilibrium constant may be estimated using the integrated van't Hoff equation:

$$\begin{aligned} \ln \left(\frac{K_{p,\text{est}}}{K_{p1}} \right) &= \frac{\bar{h}_R}{R_u} \left(\frac{1}{T_R} - \frac{1}{T} \right) \\ \ln \left(\frac{K_{p,\text{est}}}{0.2209} \right) &= \frac{-26,176 \text{ kJ/kmol}}{8.314 \text{ kJ/kmol} \cdot \text{K}} \left(\frac{1}{2000 \text{ K}} - \frac{1}{2500 \text{ K}} \right) \longrightarrow K_{p,\text{est}} = \mathbf{0.1612} \end{aligned}$$

16-39 A constant volume tank contains a mixture of H_2 and O_2 . The contents are ignited. The final temperature and pressure in the tank are to be determined.

Analysis The reaction equation with products in equilibrium is

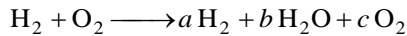

The coefficients are determined from the mass balances

$$\text{Hydrogen balance:} \quad 2 = 2a + 2b$$

$$\text{Oxygen balance:} \quad 2 = b + 2c$$

The assumed equilibrium reaction is

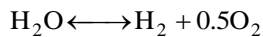

The K_p value of a reaction at a specified temperature can be determined from the Gibbs function data using

$$K_p = e^{-\Delta G^*(T)/R_u T} \quad \text{or} \quad \ln K_p = -\Delta G^*(T) / R_u T$$

where

$$\Delta G^*(T) = \nu_{\text{H}_2} \bar{g}_{\text{H}_2}^*(T_{\text{prod}}) + \nu_{\text{O}_2} \bar{g}_{\text{O}_2}^*(T_{\text{prod}}) - \nu_{\text{H}_2\text{O}} \bar{g}_{\text{H}_2\text{O}}^*(T_{\text{prod}})$$

and the Gibbs functions are given by

$$\bar{g}_{\text{H}_2}^*(T_{\text{prod}}) = (\bar{h} - T_{\text{prod}} \bar{s})_{\text{H}_2}$$

$$\bar{g}_{\text{O}_2}^*(T_{\text{prod}}) = (\bar{h} - T_{\text{prod}} \bar{s})_{\text{O}_2}$$

$$\bar{g}_{\text{H}_2\text{O}}^*(T_{\text{prod}}) = (\bar{h} - T_{\text{prod}} \bar{s})_{\text{H}_2\text{O}}$$

The equilibrium constant is also given by

$$K_p = \frac{a^1 c^{0.5}}{b^1} \left(\frac{P}{N_{\text{tot}}} \right)^{1+0.5-1} = \frac{ac^{0.5}}{b} \left(\frac{P_2 / 101.3}{a+b+c} \right)^{0.5}$$

An energy balance on the tank under adiabatic conditions gives

$$U_R = U_P$$

where

$$\begin{aligned} U_R &= 1(\bar{h}_{\text{H}_2@25^\circ\text{C}} - R_u T_{\text{reac}}) + 1(\bar{h}_{\text{O}_2@25^\circ\text{C}} - R_u T_{\text{reac}}) \\ &= 0 - (8.314 \text{ kJ/kmol}\cdot\text{K})(298.15 \text{ K}) + 0 - (8.314 \text{ kJ/kmol}\cdot\text{K})(298.15 \text{ K}) = -4958 \text{ kJ/kmol} \end{aligned}$$

$$U_P = a(\bar{h}_{\text{H}_2@T_{\text{prod}}} - R_u T_{\text{prod}}) + b(\bar{h}_{\text{H}_2\text{O}@T_{\text{prod}}} - R_u T_{\text{prod}}) + c(\bar{h}_{\text{O}_2@T_{\text{prod}}} - R_u T_{\text{prod}})$$

The relation for the final pressure is

$$P_2 = \frac{N_{\text{tot}}}{N_1} \frac{T_{\text{prod}}}{T_{\text{reac}}} P_1 = \left(\frac{a+b+c}{2} \right) \left(\frac{T_{\text{prod}}}{298.15 \text{ K}} \right) (101.3 \text{ kPa})$$

Solving all the equations simultaneously using EES, we obtain the final temperature and pressure in the tank to be

$$T_{\text{prod}} = \mathbf{3857\text{K}}$$

$$P_2 = \mathbf{1043\text{kPa}}$$

16-40 It is to be shown that as long as the extent of the reaction, α , for the disassociation reaction $X_2 \Leftrightarrow 2X$ is smaller than one, α is given by $\alpha = \sqrt{\frac{K_p}{4 + K_p}}$

Assumptions The reaction occurs at the reference temperature.

Analysis The stoichiometric and actual reactions can be written as

Stoichiometric: $X_2 \Leftrightarrow 2X$ (thus $\nu_{X_2} = 1$ and $\nu_X = 2$)

Actual: $X_2 \Leftrightarrow \underbrace{(1-\alpha)X_2}_{\text{react.}} + \underbrace{2\alpha X}_{\text{prod.}}$

The equilibrium constant K_p is given by

$$K_p = \frac{N_X^{\nu_X}}{N_{X_2}^{\nu_{X_2}}} \left(\frac{P}{N_{\text{total}}} \right)^{\nu_X - \nu_{X_2}} = \frac{(2\alpha)^2}{(1-\alpha)} \left(\frac{1}{\alpha+1} \right)^{2-1} = \frac{4\alpha^2}{(1-\alpha)(1+\alpha)}$$

Solving this expression for α gives

$$\alpha = \sqrt{\frac{K_p}{4 + K_p}}$$

Simultaneous Reactions

16-41C It can be expressed as “ $(dG)_{T,P} = 0$ for each reaction.” Or as “the K_p relation for each reaction must be satisfied.”

16-42C The number of K_p relations needed to determine the equilibrium composition of a reacting mixture is equal to the difference between the number of species present in the equilibrium mixture and the number of elements.

16-43 Two chemical reactions are occurring in a mixture. The equilibrium composition at a specified temperature is to be determined.

Assumptions 1 The equilibrium composition consists of H_2O , OH , O_2 , and H_2 .

2 The constituents of the mixture are ideal gases.

Analysis The reaction equation during this process can be expressed as

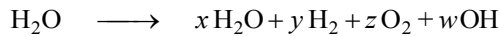

Mass balances for hydrogen and oxygen yield

$$\text{H balance:} \quad 2 = 2x + 2y + w \quad (1)$$

$$\text{O balance:} \quad 1 = x + 2z + w \quad (2)$$

The mass balances provide us with only two equations with four unknowns, and thus we need to have two more equations (to be obtained from the K_p relations) to determine the equilibrium composition of the mixture. They are



The equilibrium constant for these two reactions at 3400 K are determined from Table A-28 to be

$$\ln K_{p1} = -1.891 \longrightarrow K_{p1} = 0.15092$$

$$\ln K_{p2} = -1.576 \longrightarrow K_{p2} = 0.20680$$

The K_p relations for these two simultaneous reactions are

$$K_{p1} = \frac{N_{\text{H}_2}^{v_{\text{H}_2}} N_{\text{O}_2}^{v_{\text{O}_2}}}{N_{\text{H}_2\text{O}}^{v_{\text{H}_2\text{O}}}} \left(\frac{P}{N_{\text{total}}} \right)^{(v_{\text{H}_2} + v_{\text{O}_2} - v_{\text{H}_2\text{O}})} \quad \text{and} \quad K_{p2} = \frac{N_{\text{H}_2}^{v_{\text{H}_2}} N_{\text{OH}}^{v_{\text{OH}}}}{N_{\text{H}_2\text{O}}^{v_{\text{H}_2\text{O}}}} \left(\frac{P}{N_{\text{total}}} \right)^{(v_{\text{H}_2} + v_{\text{OH}} - v_{\text{H}_2\text{O}})}$$

$$\text{where} \quad N_{\text{total}} = N_{\text{H}_2\text{O}} + N_{\text{H}_2} + N_{\text{O}_2} + N_{\text{OH}} = x + y + z + w$$

Substituting,

$$0.15092 = \frac{(y)(z)^{1/2}}{x} \left(\frac{1}{x + y + z + w} \right)^{1/2} \quad (3)$$

$$0.20680 = \frac{(w)(y)^{1/2}}{x} \left(\frac{1}{x + y + z + w} \right)^{1/2} \quad (4)$$

Solving Eqs. (1), (2), (3), and (4) simultaneously for the four unknowns x , y , z , and w yields

$$x = 0.574 \quad y = 0.308 \quad z = 0.095 \quad w = 0.236$$

Therefore, the equilibrium composition becomes

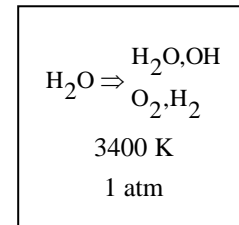
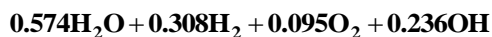

16-44 Two chemical reactions are occurring in a mixture. The equilibrium composition at a specified temperature is to be determined.

Assumptions 1 The equilibrium composition consists of CO_2 , CO , O_2 , and O . **2** The constituents of the mixture are ideal gases.

Analysis The reaction equation during this process can be expressed as

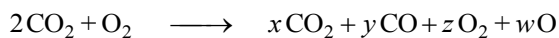

Mass balances for carbon and oxygen yield

$$\text{C balance:} \quad 2 = x + y \quad (1)$$

$$\text{O balance:} \quad 6 = 2x + y + 2z + w \quad (2)$$

$\text{CO}_2, \text{CO}, \text{O}_2, \text{O}$
3200 K
2 atm

The mass balances provide us with only two equations with four unknowns, and thus we need to have two more equations (to be obtained from the K_P relations) to determine the equilibrium composition of the mixture. They are



The equilibrium constant for these two reactions at 3200 K are determined from Table A-28 to be

$$\ln K_{P1} = -0.429 \longrightarrow K_{P1} = 0.6512$$

$$\ln K_{P2} = -3.072 \longrightarrow K_{P2} = 0.04633$$

The K_P relations for these two simultaneous reactions are

$$K_{P1} = \frac{N_{\text{CO}}^{v_{\text{CO}}} N_{\text{O}_2}^{v_{\text{O}_2}}}{N_{\text{CO}_2}^{v_{\text{CO}_2}}} \left(\frac{P}{N_{\text{total}}} \right)^{(v_{\text{CO}} + v_{\text{O}_2} - v_{\text{CO}_2})}$$

$$K_{P2} = \frac{N_{\text{O}}^{v_{\text{O}}}}{N_{\text{O}_2}^{v_{\text{O}_2}}} \left(\frac{P}{N_{\text{total}}} \right)^{v_{\text{O}} - v_{\text{O}_2}}$$

where

$$N_{\text{total}} = N_{\text{CO}_2} + N_{\text{O}_2} + N_{\text{CO}} + N_{\text{O}} = x + y + z + w$$

Substituting,

$$0.6512 = \frac{(y)(z)^{1/2}}{x} \left(\frac{2}{x + y + z + w} \right)^{1/2} \quad (3)$$

$$0.04633 = \frac{w^2}{z} \left(\frac{2}{x + y + z + w} \right)^{2-1} \quad (4)$$

Solving Eqs. (1), (2), (3), and (4) simultaneously using an equation solver such as EES for the four unknowns x , y , z , and w yields

$$x = 1.127 \quad y = 0.8727 \quad z = 1.273 \quad w = 0.3258$$

Thus the equilibrium composition is



16-45 Two chemical reactions are occurring at high-temperature air. The equilibrium composition at a specified temperature is to be determined.

Assumptions 1 The equilibrium composition consists of O_2 , N_2 , O , and NO . **2** The constituents of the mixture are ideal gases.

Analysis The reaction equation during this process can be expressed as

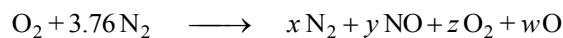

Mass balances for nitrogen and oxygen yield

$$\text{N balance:} \quad 7.52 = 2x + y \quad (1)$$

$$\text{O balance:} \quad 2 = y + 2z + w \quad (2)$$

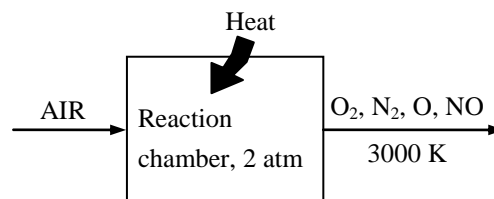

The mass balances provide us with only two equations with four unknowns, and thus we need to have two more equations (to be obtained from the K_p relations) to determine the equilibrium composition of the mixture. They are



The equilibrium constant for these two reactions at 3000 K are determined from Table A-28 to be

$$\ln K_{p1} = -2.114 \longrightarrow K_{p1} = 0.12075$$

$$\ln K_{p2} = -4.357 \longrightarrow K_{p2} = 0.01282$$

The K_p relations for these two simultaneous reactions are

$$K_{p1} = \frac{N_{NO}^{v_{NO}}}{N_{N_2}^{v_{N_2}} N_{O_2}^{v_{O_2}}} \left(\frac{P}{N_{\text{total}}} \right)^{(v_{NO} - v_{N_2} - v_{O_2})}$$

$$K_{p2} = \frac{N_O^{v_O}}{N_{O_2}^{v_{O_2}}} \left(\frac{P}{N_{\text{total}}} \right)^{v_O - v_{O_2}}$$

$$\text{where } N_{\text{total}} = N_{N_2} + N_{NO} + N_{O_2} + N_O = x + y + z + w$$

Substituting,

$$0.12075 = \frac{y}{x^{0.5} z^{0.5}} \left(\frac{2}{x + y + z + w} \right)^{1 - 0.5 - 0.5} \quad (3)$$

$$0.01282 = \frac{w^2}{z} \left(\frac{2}{x + y + z + w} \right)^{2 - 1} \quad (4)$$

Solving Eqs. (1), (2), (3), and (4) simultaneously using EES for the four unknowns x , y , z , and w yields

$$x = 3.656 \quad y = 0.2086 \quad z = 0.8162 \quad w = 0.1591$$

Thus the equilibrium composition is

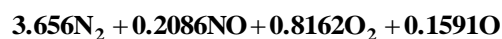

The equilibrium constant of the reaction $N_2 \Leftrightarrow 2N$ at 3000 K is $\ln K_p = -22.359$, which is much smaller than the K_p values of the reactions considered. Therefore, it is reasonable to assume that no N will be present in the equilibrium mixture.



16-46E Two chemical reactions are occurring in air. The equilibrium composition at a specified temperature is to be determined.

Assumptions **1** The equilibrium composition consists of O_2 , N_2 , O , and NO . **2** The constituents of the mixture are ideal gases.

Analysis The reaction equation during this process can be expressed as

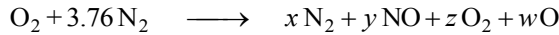

Mass balances for nitrogen and oxygen yield

$$\text{N balance: } 7.52 = 2x + y \quad (1)$$

$$\text{O balance: } 2 = y + 2z + w \quad (2)$$

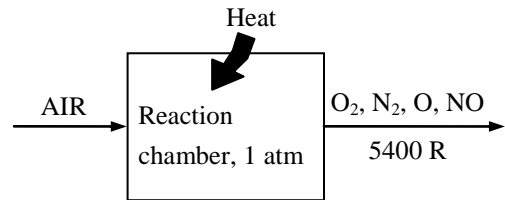

The mass balances provide us with only two equations with four unknowns, and thus we need to have two more equations (to be obtained from the K_p relations) to determine the equilibrium composition of the mixture. They are



The equilibrium constant for these two reactions at $T = 5400 \text{ R} = 3000 \text{ K}$ are determined from Table A-28 to be

$$\ln K_{P1} = -2.114 \longrightarrow K_{P1} = 0.12075$$

$$\ln K_{P2} = -4.357 \longrightarrow K_{P2} = 0.01282$$

The K_p relations for these two simultaneous reactions are

$$K_{P1} = \frac{N_{NO}^{v_{NO}}}{N_{N_2}^{v_{N_2}} N_{O_2}^{v_{O_2}}} \left(\frac{P}{N_{\text{total}}} \right)^{(v_{NO} - v_{N_2} - v_{O_2})}$$

$$K_{P2} = \frac{N_O^{v_O}}{N_{O_2}^{v_{O_2}}} \left(\frac{P}{N_{\text{total}}} \right)^{v_O - v_{O_2}}$$

$$\text{where } N_{\text{total}} = N_{N_2} + N_{NO} + N_{O_2} + N_O = x + y + z + w$$

Substituting,

$$0.12075 = \frac{y}{x^{0.5} z^{0.5}} \left(\frac{1}{x + y + z + w} \right)^{1 - 0.5 - 0.5} \quad (3)$$

$$0.01282 = \frac{w^2}{z} \left(\frac{1}{x + y + z + w} \right)^{2 - 1} \quad (4)$$

Solving Eqs. (1), (2), (3), and (4) simultaneously for the four unknowns x , y , z , and w yields

$$x = 3.658 \quad y = 0.2048 \quad z = 0.7868 \quad w = 0.2216$$

Thus the equilibrium composition is

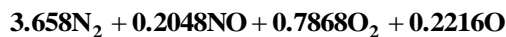

The equilibrium constant of the reaction $N_2 \Leftrightarrow 2N$ at 5400 R is $\ln K_p = -22.359$, which is much smaller than the K_p values of the reactions considered. Therefore, it is reasonable to assume that no N will be present in the equilibrium mixture.



14-47E Problem 16-46E is reconsidered. Using EES (or other) software, the equilibrium solution is to be obtained by minimizing the Gibbs function by using the optimization capabilities built into EES. This solution technique is to be compared with that used in the previous problem.

Analysis The problem is solved using EES, and the solution is given below.

"This example illustrates how EES can be used to solve multi-reaction chemical equilibria problems by directly minimizing the Gibbs function.



Two of the four coefficients, a, b, c, and d, are found by minimizing the Gibbs function at a total pressure of 1 atm and a temperature of 5400 R. The other two are found from mass balances.

The equilibrium solution can be found by applying the Law of Mass Action to two simultaneous equilibrium reactions or by minimizing the Gibbs function. In this problem, the Gibbs function is directly minimized using the optimization capabilities built into EES.

To run this program, select MinMax from the Calculate menu. There are four compounds present in the products subject to two elemental balances, so there are two degrees of freedom. Minimize Gibbs with respect to two molar quantities such as coefficients b and d. The equilibrium mole numbers of each specie will be determined and displayed in the Solution window.

Minimizing the Gibbs function to find the equilibrium composition requires good initial guesses."

"Data from Data Input Window"

```
{T=5400 "R"
P=1 "atm" }
```

AO2=0.21; BN2=0.79 "Composition of air"

AO2*2=a*2+b+d "Oxygen balance"

BN2*2=c*2+d "Nitrogen balance"

"The total moles at equilibrium are"

N_tot=a+b+c+d

y_O2=a/N_tot; y_O=b/N_tot; y_N2=c/N_tot; y_NO=d/N_tot

"The following equations provide the specific Gibbs function for three of the components."

g_O2=Enthalpy(O2,T=T)-T*Entropy(O2,T=T,P=P*y_O2)

g_N2=Enthalpy(N2,T=T)-T*Entropy(N2,T=T,P=P*y_N2)

g_NO=Enthalpy(NO,T=T)-T*Entropy(NO,T=T,P=P*y_NO)

"EES does not have a built-in property function for monatomic oxygen so we will use the JANAF procedure, found under Options/Function Info/External Procedures. The units for the JANAF procedure are kgmole, K, and kJ so we must convert h and s to English units."

T_K=T*Convert(R,K) "Convert R to K"

Call JANAF('O',T_K:Cp,h,S) "Units from JANAF are SI"

S_O=S*Convert(kJ/kgmole-K, Btu/lbmole-R)

h_O=h*Convert(kJ/kgmole, Btu/lbmole)

"The entropy from JANAF is for one atmosphere so it must be corrected for partial pressure."

g_O=h_O-T*(S_O-R_u*ln(Y_O))

R_u=1.9858 "The universal gas constant in Btu/mole-R"

"The extensive Gibbs function is the sum of the products of the specific Gibbs function and the molar amount of each substance."

Gibbs=a*g_O2+b*g_O+c*g_N2+d*g_NO

d [lbmol]	b [lbmol]	Gibbs [Btu/lbmol]	y_{O_2}	y_O	y_{NO}	y_{N_2}	T [R]
0.002698	0.00001424	-162121	0.2086	0.0000	0.0027	0.7886	3000
0.004616	0.00006354	-178354	0.2077	0.0001	0.0046	0.7877	3267
0.007239	0.0002268	-194782	0.2062	0.0002	0.0072	0.7863	3533
0.01063	0.000677	-211395	0.2043	0.0007	0.0106	0.7844	3800
0.01481	0.001748	-228188	0.2015	0.0017	0.0148	0.7819	4067
0.01972	0.004009	-245157	0.1977	0.0040	0.0197	0.7786	4333
0.02527	0.008321	-262306	0.1924	0.0083	0.0252	0.7741	4600
0.03132	0.01596	-279641	0.1849	0.0158	0.0311	0.7682	4867
0.03751	0.02807	-297179	0.1748	0.0277	0.0370	0.7606	5133
0.04361	0.04641	-314941	0.1613	0.0454	0.0426	0.7508	5400

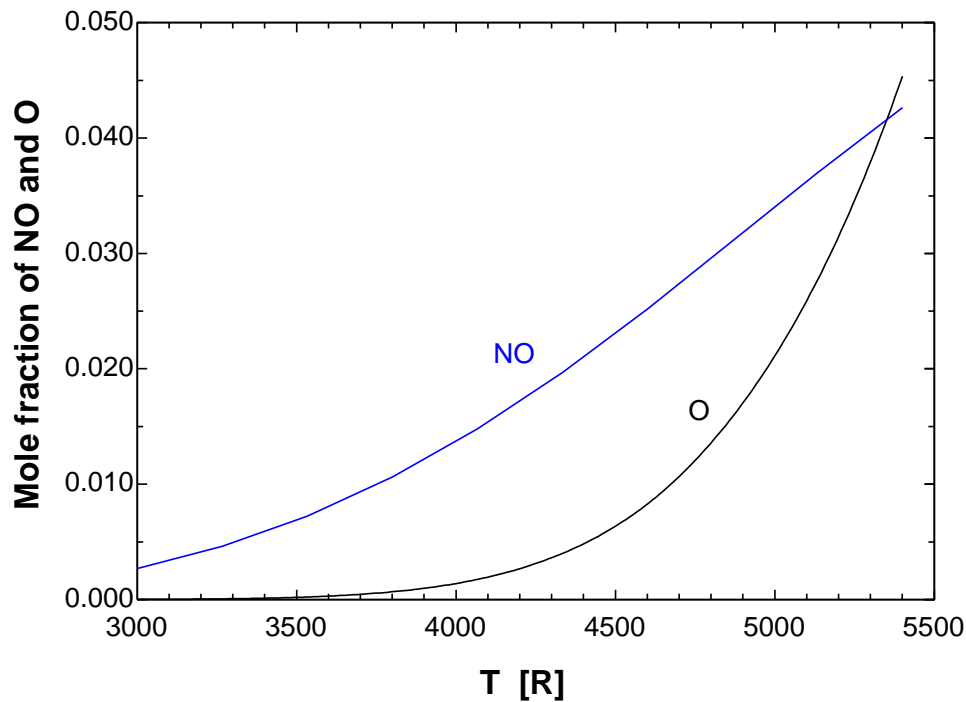

Discussion The equilibrium composition in the above table are based on the reaction in which the reactants are 0.21 kmol O_2 and 0.79 kmol N_2 . If you multiply the equilibrium composition mole numbers above with 4.76, you will obtain equilibrium composition for the reaction in which the reactants are 1 kmol O_2 and 3.76 kmol N_2 . This is the case in problem 16-46E.

16-48 Water vapor is heated during a steady-flow process. The rate of heat supply for a specified exit temperature is to be determined for two cases.

Assumptions 1 The equilibrium composition consists of H_2O , OH , O_2 , and H_2 . **2** The constituents of the mixture are ideal gases.

Analysis (a) Assuming some H_2O dissociates into H_2 , O_2 , and O , the dissociation equation can be written as

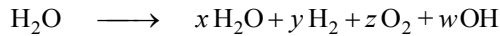

Mass balances for hydrogen and oxygen yield

$$\text{H balance:} \quad 2 = 2x + 2y + w \quad (1)$$

$$\text{O balance:} \quad 1 = x + 2z + w \quad (2)$$

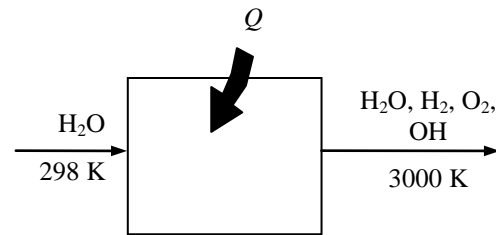

The mass balances provide us with only two equations with four unknowns, and thus we need to have two more equations (to be obtained from the K_p relations) to determine the equilibrium composition of the mixture. They are



The equilibrium constant for these two reactions at 3000 K are determined from Table A-28 to be

$$\ln K_{p1} = -3.086 \longrightarrow K_{p1} = 0.04568$$

$$\ln K_{p2} = -2.937 \longrightarrow K_{p2} = 0.05302$$

The K_p relations for these three simultaneous reactions are

$$K_{p1} = \frac{N_{\text{H}_2}^{\nu_{\text{H}_2}} N_{\text{O}_2}^{\nu_{\text{O}_2}}}{N_{\text{H}_2\text{O}}^{\nu_{\text{H}_2\text{O}}}} \left(\frac{P}{N_{\text{total}}} \right)^{(\nu_{\text{H}_2} + \nu_{\text{O}_2} - \nu_{\text{H}_2\text{O}})}$$

$$K_{p2} = \frac{N_{\text{H}_2}^{\nu_{\text{H}_2}} N_{\text{OH}}^{\nu_{\text{OH}}}}{N_{\text{H}_2\text{O}}^{\nu_{\text{H}_2\text{O}}}} \left(\frac{P}{N_{\text{total}}} \right)^{(\nu_{\text{H}_2} + \nu_{\text{OH}} - \nu_{\text{H}_2\text{O}})}$$

where

$$N_{\text{total}} = N_{\text{H}_2\text{O}} + N_{\text{H}_2} + N_{\text{O}_2} + N_{\text{OH}} = x + y + z + w$$

Substituting,

$$0.04568 = \frac{(y)(z)^{1/2}}{x} \left(\frac{1}{x + y + z + w} \right)^{1/2} \quad (3)$$

$$0.05302 = \frac{(w)(y)^{1/2}}{x} \left(\frac{1}{x + y + z + w} \right)^{1/2} \quad (4)$$

Solving Eqs. (1), (2), (3), and (4) simultaneously for the four unknowns x , y , z , and w yields

$$x = 0.7835 \quad y = 0.1622 \quad z = 0.05396 \quad w = 0.1086$$

Thus the balanced equation for the dissociation reaction is

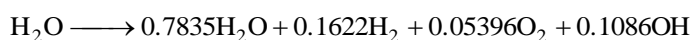

The heat transfer for this dissociation process is determined from the steady-flow energy balance $E_{\text{in}} - E_{\text{out}} = \Delta E_{\text{system}}$ with $W = 0$,

$$Q_{\text{in}} = \sum N_P (\bar{h}_f^\circ + \bar{h} - \bar{h}^\circ)_P - \sum N_R (\bar{h}_f^\circ + \bar{h} - \bar{h}^\circ)_R$$

Assuming the O_2 and O to be ideal gases, we have $h = h(T)$. From the tables,

Substance	\bar{h}_f° kJ/kmol	$\bar{h}_{298\text{ K}}$ kJ/kmol	$\bar{h}_{3000\text{ K}}$ kJ/kmol
H_2O	-241,820	9904	136,264
H_2	0	8468	97,211
O_2	0	8682	106,780
OH	39,460	9188	98,763

Substituting,

$$\begin{aligned}
 Q_{in} &= 0.7835(-241,820 + 136,264 - 9904) \\
 &\quad + 0.1622(0 + 97,211 - 8468) \\
 &\quad + 0.05396(0 + 106,780 - 8682) \\
 &\quad + 0.1086(39,460 + 98,763 - 9188) - (-241,820) \\
 &= 185,058 \text{ kJ/kmol } H_2O
 \end{aligned}$$

The mass flow rate of H_2O can be expressed in terms of the mole numbers as

$$\dot{N} = \frac{\dot{m}}{M} = \frac{0.2 \text{ kg/min}}{18 \text{ kg/kmol}} = 0.01111 \text{ kmol/min}$$

Thus,

$$\dot{Q}_{in} = \dot{N} \times Q_{in} = (0.01111 \text{ kmol/min})(185,058 \text{ kJ/kmol}) = \mathbf{2056 \text{ kJ/min}}$$

(b) If no dissociates takes place, then the process involves no chemical reactions and the heat transfer can be determined from the steady-flow energy balance for nonreacting systems to be

$$\begin{aligned}
 \dot{Q}_{in} &= \dot{m}(h_2 - h_1) = \dot{N}(\bar{h}_2 - \bar{h}_1) \\
 &= (0.01111 \text{ kmol/min})(136,264 - 9904) \text{ kJ/kmol} \\
 &= \mathbf{1404 \text{ kJ/min}}
 \end{aligned}$$



16-49 Problem 16-48 is reconsidered. The effect of the final temperature on the rate of heat supplied for the two cases is to be studied.

Analysis The problem is solved using EES, and the solution is given below.

"Given"

$$T1=298 \text{ [K]}$$

$$T2=3000 \text{ [K]}$$

$$P=1 \text{ [atm]}$$

$$\dot{m}=0.2 \text{ [kg/min]}$$

$$T0=298 \text{ [K]}$$

"The equilibrium constant for these two reactions at 3000 K are determined from Table A-28"

$$K_{p1}=\exp(-3.086)$$

$$K_{p2}=\exp(-2.937)$$

"Properties"

$$MM_{H2O}=\text{molarmass}(H2O)$$

"Analysis"

"(a)"

"Actual reaction: $H_2O = N_{H_2O} H_2O + N_{H_2} H_2 + N_{O_2} O_2 + N_{OH} OH$ "

$$2=2*N_{H_2O}+2*N_{H_2}+N_{OH} \text{ "H balance"}$$

$$1=N_{H_2O}+2*N_{O_2}+N_{OH} \text{ "O balance"}$$

$$N_{total}=N_{H_2O}+N_{H_2}+N_{O_2}+N_{OH}$$

"Stoichiometric reaction 1: $H_2O = H_2 + 1/2 O_2$ "

"Stoichiometric coefficients for reaction 1"

$$\nu_{H_2O_1}=1$$

$$\nu_{H_2_1}=1$$

$$\nu_{O_2_1}=1/2$$

"Stoichiometric reaction 2: $H_2O = 1/2 H_2 + OH$ "

"Stoichiometric coefficients for reaction 2"

$$\nu_{H_2O_2}=1$$

$$\nu_{H_2_2}=1/2$$

$$\nu_{OH_2}=1$$

"K_p relations are"

$$K_{p1}=(N_{H_2}^{\nu_{H_2_1}} N_{O_2}^{\nu_{O_2_1}}) / (N_{H_2O}^{\nu_{H_2O_1}} (P/N_{total})^{(\nu_{H_2_1} + \nu_{O_2_1} - \nu_{H_2O_1})}$$

$$K_{p2}=(N_{H_2}^{\nu_{H_2_2}} N_{OH}^{\nu_{OH_2}}) / (N_{H_2O}^{\nu_{H_2O_2}} (P/N_{total})^{(\nu_{H_2_2} + \nu_{OH_2} - \nu_{H_2O_2})}$$

"Enthalpy of formation data from Table A-26"

$$h_{f_OH}=39460$$

"Enthalpies of products"

$$h_{H_2O_R}=\text{enthalpy}(H_2O, T=T1)$$

$$h_{H_2O_P}=\text{enthalpy}(H_2O, T=T2)$$

$$h_{H_2}=\text{enthalpy}(H_2, T=T2)$$

$$h_{O_2}=\text{enthalpy}(O_2, T=T2)$$

$$h_{OH}=98763 \text{ "at } T2 \text{ from the ideal gas tables in the text"}$$

"Standard state enthalpies"

$$h_{o_OH}=9188 \text{ "at } T0 \text{ from the ideal gas tables in the text"}$$

"Heat transfer"

$$H_P=N_{H_2O} h_{H_2O_P} + N_{H_2} h_{H_2} + N_{O_2} h_{O_2} + N_{OH} (h_{f_OH} + h_{OH} - h_{o_OH})$$

$$H_R=N_{H_2O_R} h_{H_2O_R}$$

$$N_{H_2O_R}=1$$

$$Q_{in_a}=H_P - H_R$$

$$\dot{Q}_{in_a}=(\dot{m}/MM_{H_2O}) * Q_{in_a}$$

"(b)"

$$Q_{in_b}=N_{H_2O_R} (h_{H_2O_P} - h_{H_2O_R})$$

$$\dot{Q}_{in_b}=(\dot{m}/MM_{H_2O}) * Q_{in_b}$$

P [atm]	$\dot{Q}_{in,Dissoc}$ [kJ/min]	$\dot{Q}_{in,NoDissoc}$ [kJ/min]
1	2066	1417
2	1946	1417
3	1885	1417
4	1846	1417
5	1818	1417
6	1796	1417
7	1778	1417
8	1763	1417
9	1751	1417
10	1740	1417

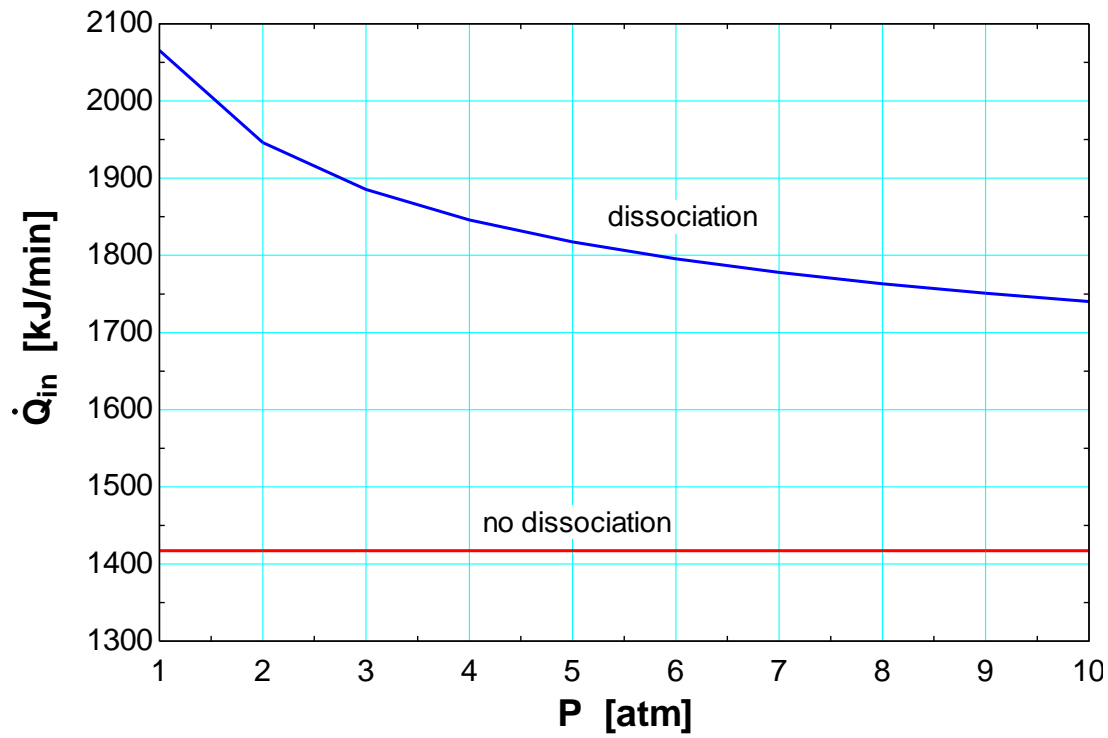

16-50  Ethyl alcohol C_2H_5OH (gas) is burned in a steady-flow adiabatic combustion chamber with 40 percent excess air. The adiabatic flame temperature of the products is to be determined and the adiabatic flame temperature as a function of the percent excess air is to be plotted.

Analysis The complete combustion reaction in this case can be written as

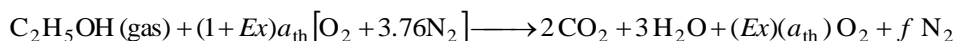

where a_{th} is the stoichiometric coefficient for air. The oxygen balance gives

$$1 + (1 + Ex)a_{th} \times 2 = 2 \times 2 + 3 \times 1 + (Ex)(a_{th}) \times 2$$

The reaction equation with products in equilibrium is

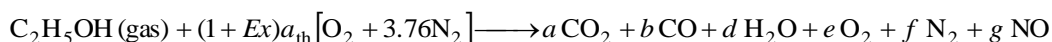

The coefficients are determined from the mass balances

Carbon balance: $2 = a + b$

Hydrogen balance: $6 = 2d \longrightarrow d = 3$

Oxygen balance: $1 + (1 + Ex)a_{th} \times 2 = a \times 2 + b + d + e \times 2 + g$

Nitrogen balance: $(1 + Ex)a_{th} \times 3.76 \times 2 = f \times 2 + g$

Solving the above equations, we find the coefficients to be

$$Ex = 0.4, a_{th} = 3, a = 1.995, b = 0.004712, d = 3, e = 1.17, f = 15.76, g = 0.06428$$

Then, we write the balanced reaction equation as

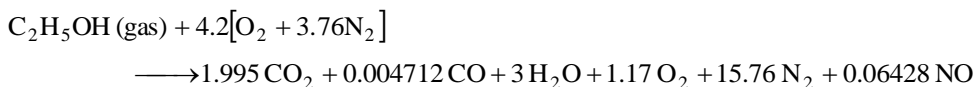

Total moles of products at equilibrium are

$$N_{tot} = 1.995 + 0.004712 + 3 + 1.17 + 15.76 = 21.99$$

The first assumed equilibrium reaction is

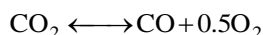

The K_p value of a reaction at a specified temperature can be determined from the Gibbs function data using

$$K_{p1} = \exp\left(\frac{-\Delta G_1^*(T_{prod})}{R_u T_{prod}}\right)$$

Where $\Delta G_1^*(T_{prod}) = \nu_{CO} \bar{g}_{CO}^*(T_{prod}) + \nu_{O_2} \bar{g}_{O_2}^*(T_{prod}) - \nu_{CO_2} \bar{g}_{CO_2}^*(T_{prod})$

and the Gibbs functions are defined as

$$\bar{g}_{CO}^*(T_{prod}) = (\bar{h} - T_{prod} \bar{s})_{CO}$$

$$\bar{g}_{O_2}^*(T_{prod}) = (\bar{h} - T_{prod} \bar{s})_{O_2}$$

$$\bar{g}_{CO_2}^*(T_{prod}) = (\bar{h} - T_{prod} \bar{s})_{CO_2}$$

The equilibrium constant is also given by

$$K_{p1} = \frac{b e^{0.5}}{a} \left(\frac{P}{N_{tot}}\right)^{1+0.5-1} = \frac{(0.004712)(1.17)^{0.5}}{1.995} \left(\frac{1}{21.99}\right)^{0.5} = 0.0005447$$

The second assumed equilibrium reaction is

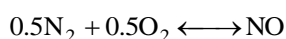

Also, for this reaction, we have

$$\bar{g}_{\text{NO}}^*(T_{\text{prod}}) = (\bar{h} - T_{\text{prod}}\bar{s})_{\text{NO}}$$

$$\bar{g}_{\text{N}_2}^*(T_{\text{prod}}) = (\bar{h} - T_{\text{prod}}\bar{s})_{\text{N}_2}$$

$$\bar{g}_{\text{O}_2}^*(T_{\text{prod}}) = (\bar{h} - T_{\text{prod}}\bar{s})_{\text{O}_2}$$

$$\Delta G_2^*(T_{\text{prod}}) = \nu_{\text{NO}}\bar{g}_{\text{NO}}^*(T_{\text{prod}}) - \nu_{\text{N}_2}\bar{g}_{\text{N}_2}^*(T_{\text{prod}}) - \nu_{\text{O}_2}\bar{g}_{\text{O}_2}^*(T_{\text{prod}})$$

$$K_{p2} = \exp\left(\frac{-\Delta G_2^*(T_{\text{prod}})}{R_u T_{\text{prod}}}\right)$$

$$K_{p2} = \left(\frac{P}{N_{\text{tot}}}\right)^{1-0.5-0.5} \frac{g}{e^{0.5} f^{0.5}} = \left(\frac{1}{21.99}\right)^0 \frac{0.06428}{(1.17)^{0.5} (15.76)^{0.5}} = 0.01497$$

A steady flow energy balance gives

$$H_R = H_P$$

where

$$\begin{aligned} H_R &= \bar{h}_{f,\text{fuel}@25^\circ\text{C}}^\circ + 4.2\bar{h}_{\text{O}_2@25^\circ\text{C}} + 15.79\bar{h}_{\text{N}_2@25^\circ\text{C}} \\ &= (-235,310 \text{ kJ/kmol}) + 4.2(0) + 15.79(0) = -235,310 \text{ kJ/kmol} \end{aligned}$$

$$H_P = 1.995\bar{h}_{\text{CO}_2@T_{\text{prod}}} + 0.004712\bar{h}_{\text{CO}@T_{\text{prod}}} + 3h_{\text{H}_2\text{O}@T_{\text{prod}}} + 1.17\bar{h}_{\text{O}_2@T_{\text{prod}}} + 15.76\bar{h}_{\text{N}_2@T_{\text{prod}}} + 0.06428\bar{h}_{\text{NO}@T_{\text{prod}}}$$

Solving the energy balance equation using EES, we obtain the adiabatic flame temperature

$$T_{\text{prod}} = \mathbf{1901 \text{ K}}$$

The copy of entire EES solution including parametric studies is given next:

"The reactant temperature is:"

T_reac= 25+273 "[K]"

"For adiabatic combustion of 1 kmol of fuel: "

Q_out = 0 "[kJ]"

PercentEx = 40 "Percent excess air"

Ex = PercentEx/100 "EX = % Excess air/100"

P_prod = 101.3 "[kPa]"

R_u = 8.314 "[kJ/kmol-K]"

"The complete combustion reaction equation for excess air is:"

"C2H5OH(gas)+ (1+Ex)*A_th (O2 +3.76N2)=2 CO2 + 3 H2O + Ex*A_th O2 + f N2 "

"Oxygen Balance for complete combustion:"

1 + (1+Ex)*A_th*2=2*2+3*1 + Ex*A_th*2

"The reaction equation for excess air and products in equilibrium is:"

"C2H5OH(gas)+ (1+Ex)*A_th (O2 +3.76N2)=a CO2 + b CO+ d H2O + e O2 + f N2 + g NO"

"Carbon Balance:"

2=a + b

"Hydrogen Balance:"

6=2*d

"Oxygen Balance:"

1 + (1+Ex)*A_th*2=a*2+b + d + e*2 + g

"Nitrogen Balance:"

(1+Ex)*A_th*3.76 *2= f*2 + g

N_tot =a +b + d + e + f + g "Total kilomoles of products at equilibrium"

"The first assumed equilibrium reaction is CO2=CO+0.5O2"

"The following equations provide the specific Gibbs function (g=h-Ts) for each component in the product gases as a function of its temperature, T_prod, at 1 atm pressure, 101.3 kPa"

g_CO2=Enthalpy(CO2,T=T_prod)-T_prod *Entropy(CO2,T=T_prod ,P=101.3)

g_CO=Enthalpy(CO,T=T_prod)-T_prod *Entropy(CO,T=T_prod ,P=101.3)

g_O2=Enthalpy(O2,T=T_prod)-T_prod *Entropy(O2,T=T_prod ,P=101.3)

"The standard-state Gibbs function is"

$$\text{DELTA}G_1 = 1 \cdot g_{\text{CO}} + 0.5 \cdot g_{\text{O}_2} - 1 \cdot g_{\text{CO}_2}$$

"The equilibrium constant is given by Eq. 15-14."

$$K_{P_1} = \exp(-\text{DELTA}G_1 / (R_u \cdot T_{\text{prod}}))$$

$$P = P_{\text{prod}} / 101.3 \text{ "atm"}$$

"The equilibrium constant is also given by Eq. 15-15."

$$K_{P_1} = (P/N_{\text{tot}})^{(1+0.5-1)} \cdot (b^1 \cdot e^{0.5}) / (a^1)$$

$$\sqrt{P/N_{\text{tot}}} \cdot b \cdot \sqrt{e} = K_{P_1} \cdot a$$

"The econd assumed equilibrium reaction is $0.5\text{N}_2 + 0.5\text{O}_2 = \text{NO}$ "

$$g_{\text{NO}} = \text{Enthalpy}(\text{NO}, T=T_{\text{prod}}) - T_{\text{prod}} \cdot \text{Entropy}(\text{NO}, T=T_{\text{prod}}, P=101.3)$$

$$g_{\text{N}_2} = \text{Enthalpy}(\text{N}_2, T=T_{\text{prod}}) - T_{\text{prod}} \cdot \text{Entropy}(\text{N}_2, T=T_{\text{prod}}, P=101.3)$$

"The standard-state Gibbs function is"

$$\text{DELTA}G_2 = 1 \cdot g_{\text{NO}} - 0.5 \cdot g_{\text{O}_2} - 0.5 \cdot g_{\text{N}_2}$$

"The equilibrium constant is given by Eq. 15-14."

$$K_{P_2} = \exp(-\text{DELTA}G_2 / (R_u \cdot T_{\text{prod}}))$$

"The equilibrium constant is also given by Eq. 15-15."

$$K_{P_2} = (P/N_{\text{tot}})^{(1-0.5-0.5)} \cdot (g^1) / (e^{0.5} \cdot f^{0.5})$$

$$g = K_{P_2} \cdot \sqrt{e \cdot f}$$

"The steady-flow energy balance is:"

$$H_R = Q_{\text{out}} + H_P$$

$$h_{\text{bar}_f} \text{C}_2\text{H}_5\text{OH}_{\text{gas}} = -235310 \text{ "[kJ/kmol]"}$$

$$H_R = 1 \cdot (h_{\text{bar}_f} \text{C}_2\text{H}_5\text{OH}_{\text{gas}})$$

$$+ (1+Ex) \cdot A_{\text{th}} \cdot \text{ENTHALPY}(\text{O}_2, T=T_{\text{reac}}) + (1+Ex) \cdot A_{\text{th}} \cdot 3.76 \cdot \text{ENTHALPY}(\text{N}_2, T=T_{\text{reac}}) \text{ "[kJ/kmol]"}$$

$$H_P = a \cdot \text{ENTHALPY}(\text{CO}_2, T=T_{\text{prod}}) + b \cdot \text{ENTHALPY}(\text{CO}, T=T_{\text{prod}}) + d \cdot \text{ENTHALPY}(\text{H}_2\text{O}, T=T_{\text{prod}}) + e \cdot \text{ENTHALPY}(\text{O}_2, T=T_{\text{prod}}) + f \cdot \text{ENTHALPY}(\text{N}_2, T=T_{\text{prod}}) + g \cdot \text{ENTHALPY}(\text{NO}, T=T_{\text{prod}}) \text{ "[kJ/kmol]"}$$

a_{th}	a	b	d	e	f	g	PercentEx [%]	T_{prod} [K]
3	1.922	0.07779	3	0.3081	12.38	0.0616	10	2184
3	1.971	0.0293	3	0.5798	13.5	0.06965	20	2085
3	1.988	0.01151	3	0.8713	14.63	0.06899	30	1989
3	1.995	0.004708	3	1.17	15.76	0.06426	40	1901
3	1.998	0.001993	3	1.472	16.89	0.05791	50	1820
3	1.999	0.0008688	3	1.775	18.02	0.05118	60	1747
3	2	0.0003884	3	2.078	19.15	0.04467	70	1682
3	2	0.0001774	3	2.381	20.28	0.03867	80	1621
3	2	0.00008262	3	2.683	21.42	0.0333	90	1566
3	2	0.00003914	3	2.986	22.55	0.02856	100	1516

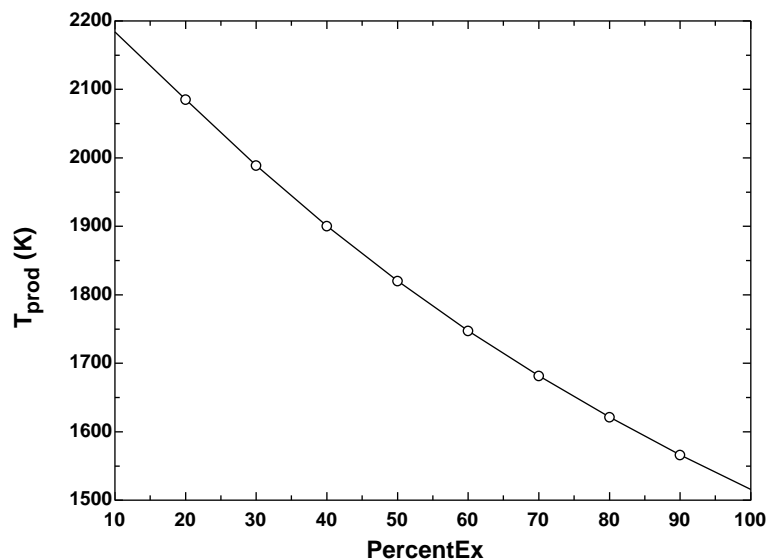

Variations of K_p with Temperature

16-51C It enables us to determine the enthalpy of reaction \bar{h}_R from a knowledge of equilibrium constant K_p .

16-52C At 2000 K since combustion processes are exothermic, and exothermic reactions are more complete at lower temperatures.

16-53 The \bar{h}_R value for the dissociation process $O_2 \Leftrightarrow 2O$ at a specified temperature is to be determined using enthalpy and K_p data.

Assumptions Both the reactants and products are ideal gases.

Analysis (a) The dissociation equation of O_2 can be expressed as

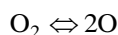

The \bar{h}_R of the dissociation process of O_2 at 3100 K is the amount of energy absorbed or released as one kmol of O_2 dissociates in a steady-flow combustion chamber at a temperature of 3100 K, and can be determined from

$$\bar{h}_R = \sum N_P (\bar{h}_f^\circ + \bar{h} - \bar{h}^\circ)_P - \sum N_R (\bar{h}_f^\circ + \bar{h} - \bar{h}^\circ)_R$$

Assuming the O_2 and O to be ideal gases, we have $h = h(T)$. From the tables,

Substance	\bar{h}_f° kJ/kmol	$\bar{h}_{298\text{ K}}$ kJ/kmol	$\bar{h}_{2900\text{ K}}$ kJ/kmol
O	249,190	6852	65,520
O_2	0	8682	110,784

Substituting,

$$\begin{aligned} \bar{h}_R &= 2(249,190 + 65,520 - 6852) - 1(0 + 110,784 - 8682) \\ &= \mathbf{513,614\text{ kJ/kmol}} \end{aligned}$$

(b) The \bar{h}_R value at 3100 K can be estimated by using K_p values at 3000 K and 3200 K (the closest two temperatures to 3100 K for which K_p data are available) from Table A-28,

$$\begin{aligned} \ln \frac{K_{P2}}{K_{P1}} &\cong \frac{\bar{h}_R}{R_u} \left(\frac{1}{T_1} - \frac{1}{T_2} \right) \quad \text{or} \quad \ln K_{P2} - \ln K_{P1} \cong \frac{\bar{h}_R}{R_u} \left(\frac{1}{T_1} - \frac{1}{T_2} \right) \\ -3.072 - (-4.357) &\cong \frac{\bar{h}_R}{8.314\text{ kJ/kmol}\cdot\text{K}} \left(\frac{1}{3000\text{ K}} - \frac{1}{3200\text{ K}} \right) \\ \bar{h}_R &\cong \mathbf{512,808\text{ kJ/kmol}} \end{aligned}$$

16-54 The \bar{h}_R at a specified temperature is to be determined using the enthalpy and K_P data.

Assumptions Both the reactants and products are ideal gases.

Analysis (a) The complete combustion equation of CO can be expressed as

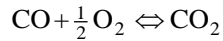

The \bar{h}_R of the combustion process of CO at 1800 K is the amount of energy released as one kmol of CO is burned in a steady-flow combustion chamber at a temperature of 1800 K, and can be determined from

$$\bar{h}_R = \sum N_P (\bar{h}_f^\circ + \bar{h} - \bar{h}^\circ)_P - \sum N_R (\bar{h}_f^\circ + \bar{h} - \bar{h}^\circ)_R$$

Assuming the CO, O₂ and CO₂ to be ideal gases, we have $h = h(T)$. From the tables,

Substance	\bar{h}_f° kJ/kmol	$\bar{h}_{298\text{ K}}$ kJ/kmol	$\bar{h}_{1800\text{ K}}$ kJ/kmol
CO ₂	-393,520	9364	88,806
CO	-110,530	8669	58,191
O ₂	0	8682	60,371

Substituting,

$$\begin{aligned} \bar{h}_R &= 1(-393,520 + 88,806 - 9904) \\ &\quad - 1(-110,530 + 58,191 - 8669) \\ &\quad - 0.5(0 + 60,371 - 8682) \\ &= -289,455 \text{ kJ/kmol} \end{aligned}$$

(b) The \bar{h}_R value at 1800 K can be estimated by using K_P values at 1600 K and 2000 K (the closest two temperatures to 1800 K for which K_P data are available) from Table A-28,

$$\begin{aligned} \ln \frac{K_{P2}}{K_{P1}} &\cong \frac{\bar{h}_R}{R_u} \left(\frac{1}{T_1} - \frac{1}{T_2} \right) \quad \text{or} \quad \ln K_{P2} - \ln K_{P1} \cong \frac{\bar{h}_R}{R_u} \left(\frac{1}{T_1} - \frac{1}{T_2} \right) \\ 6.635 - 10.830 &\cong \frac{\bar{h}_R}{8.314 \text{ kJ/kmol} \cdot \text{K}} \left(\frac{1}{1600 \text{ K}} - \frac{1}{2000 \text{ K}} \right) \\ \bar{h}_R &\cong -279,020 \text{ kJ/kmol} \end{aligned}$$

16-55E The \bar{h}_R at a specified temperature is to be determined using the enthalpy and K_P data.

Assumptions Both the reactants and products are ideal gases.

Analysis (a) The complete combustion equation of CO can be expressed as

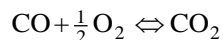

The \bar{h}_R of the combustion process of CO at 3960 R is the amount of energy released as one kmol of H_2 is burned in a steady-flow combustion chamber at a temperature of 3960 R, and can be determined from

$$\bar{h}_R = \sum N_P (\bar{h}_f^\circ + \bar{h} - \bar{h}^\circ)_P - \sum N_R (\bar{h}_f^\circ + \bar{h} - \bar{h}^\circ)_R$$

Assuming the CO, O_2 and CO_2 to be ideal gases, we have $h = h(T)$. From the tables,

Substance	\bar{h}_f° Btu/lbmol	$\bar{h}_{537\text{ R}}$ Btu/lbmol	$\bar{h}_{3960\text{ R}}$ Btu/lbmol
CO_2	-169,300	4027.5	48,647
CO	-47,540	3725.1	31,256.5
O_2	0	3725.1	32,440.5

Substituting,

$$\begin{aligned} \bar{h}_R &= 1(-169,300 + 48,647 - 4027.5) \\ &\quad - 1(-47,540 + 31,256.5 - 3725.1) \\ &\quad - 0.5(0 + 32,440.5 - 3725.1) \\ &= \mathbf{-119,030 \text{ Btu/lbmol}} \end{aligned}$$

(b) The \bar{h}_R value at 3960 R can be estimated by using K_P values at 3600 R and 4320 R (the closest two temperatures to 3960 R for which K_P data are available) from Table A-28,

$$\begin{aligned} \ln \frac{K_{P2}}{K_{P1}} &\cong \frac{\bar{h}_R}{R_u} \left(\frac{1}{T_1} - \frac{1}{T_2} \right) \quad \text{or} \quad \ln K_{P2} - \ln K_{P1} \cong \frac{\bar{h}_R}{R_u} \left(\frac{1}{T_1} - \frac{1}{T_2} \right) \\ 3.860 - 6.635 &\cong \frac{\bar{h}_R}{1.986 \text{ Btu/lbmol} \cdot \text{R}} \left(\frac{1}{3600 \text{ R}} - \frac{1}{4320 \text{ R}} \right) \\ \bar{h}_R &\cong \mathbf{-119,041 \text{ Btu/lbmol}} \end{aligned}$$

16-56 The K_p value of the combustion process $\text{H}_2 + 1/2\text{O}_2 \rightleftharpoons \text{H}_2\text{O}$ is to be determined at a specified temperature using \bar{h}_R data and K_p value.

Assumptions Both the reactants and products are ideal gases.

Analysis The \bar{h}_R and K_p data are related to each other by

$$\ln \frac{K_{p2}}{K_{p1}} \cong \frac{\bar{h}_R}{R_u} \left(\frac{1}{T_1} - \frac{1}{T_2} \right) \quad \text{or} \quad \ln K_{p2} - \ln K_{p1} \cong \frac{\bar{h}_R}{R_u} \left(\frac{1}{T_1} - \frac{1}{T_2} \right)$$

The \bar{h}_R of the specified reaction at 2400 K is the amount of energy released as one kmol of H_2 is burned in a steady-flow combustion chamber at a temperature of 2400 K, and can be determined from

$$\bar{h}_R = \sum N_P (\bar{h}_f^\circ + \bar{h} - \bar{h}^\circ)_P - \sum N_R (\bar{h}_f^\circ + \bar{h} - \bar{h}^\circ)_R$$

Assuming the H_2O , H_2 and O_2 to be ideal gases, we have $h = h(T)$. From the tables,

Substance	\bar{h}_f° kJ/kmol	$\bar{h}_{298\text{K}}$ kJ/kmol	$\bar{h}_{2400\text{K}}$ kJ/kmol
H_2O	-241,820	9904	103,508
H_2	0	8468	75,383
O_2	0	8682	83,174

Substituting,

$$\begin{aligned} \bar{h}_R &= 1(-241,820 + 103,508 - 9904) \\ &\quad - 1(0 + 75,383 - 8468) \\ &\quad - 0.5(0 + 83,174 - 8682) \\ &= -252,377 \text{ kJ/kmol} \end{aligned}$$

The K_p value at 2600 K can be estimated from the equation above by using this \bar{h}_R value and the K_p value at 2200 K which is $\ln K_{p1} = 6.768$ or $K_{p1} = 869.6$,

$$\ln(K_{p2}/869.6) \cong \frac{-252,377 \text{ kJ/kmol}}{8.314 \text{ kJ/kmol} \cdot \text{K}} \left(\frac{1}{2200 \text{ K}} - \frac{1}{2600 \text{ K}} \right)$$

$$\ln K_{p2} = 4.645 \quad (\text{Table A - 28: } \ln K_{p2} = 4.648)$$

or

$$K_{p2} = \mathbf{104.1}$$

16-57 The \bar{h}_R value for the dissociation process $\text{CO}_2 \leftrightarrow \text{CO} + 1/2\text{O}_2$ at a specified temperature is to be determined using enthalpy and K_p data.

Assumptions Both the reactants and products are ideal gases.

Analysis (a) The dissociation equation of CO_2 can be expressed as

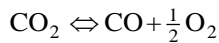

The \bar{h}_R of the dissociation process of CO_2 at 2200 K is the amount of energy absorbed or released as one kmol of CO_2 dissociates in a steady-flow combustion chamber at a temperature of 2200 K, and can be determined from

$$\bar{h}_R = \sum N_P (\bar{h}_f^\circ + \bar{h} - \bar{h}^\circ)_P - \sum N_R (\bar{h}_f^\circ + \bar{h} - \bar{h}^\circ)_R$$

Assuming the CO , O_2 and CO_2 to be ideal gases, we have $h = h(T)$. From the tables,

Substance	\bar{h}_f° kJ/kmol	$\bar{h}_{298\text{ K}}$ kJ/kmol	$\bar{h}_{2200\text{ K}}$ kJ/kmol
CO_2	-393,520	9364	112,939
CO	-110,530	8669	72,688
O_2	0	8682	75,484

Substituting,

$$\begin{aligned} \bar{h}_R &= 1(-110,530 + 72,688 - 8669) \\ &\quad + 0.5(0 + 75,484 - 8682) \\ &\quad - 1(-393,520 + 112,939 - 9364) \\ &= \mathbf{276,835\text{ kJ/kmol}} \end{aligned}$$

(b) The \bar{h}_R value at 2200 K can be estimated by using K_p values at 2000 K and 2400 K (the closest two temperatures to 2200 K for which K_p data are available) from Table A-28,

$$\begin{aligned} \ln \frac{K_{P2}}{K_{P1}} &\cong \frac{\bar{h}_R}{R_u} \left(\frac{1}{T_1} - \frac{1}{T_2} \right) \quad \text{or} \quad \ln K_{P2} - \ln K_{P1} \cong \frac{\bar{h}_R}{R_u} \left(\frac{1}{T_1} - \frac{1}{T_2} \right) \\ -3.860 - (-6.635) &\cong \frac{\bar{h}_R}{8.314\text{ kJ/kmol} \cdot \text{K}} \left(\frac{1}{2000\text{ K}} - \frac{1}{2400\text{ K}} \right) \\ \bar{h}_R &\cong \mathbf{276,856\text{ kJ/kmol}} \end{aligned}$$

16-58 The enthalpy of reaction for the equilibrium reaction $\text{CH}_4 + 2\text{O}_2 = \text{CO}_2 + 2\text{H}_2\text{O}$ at 2500 K is to be estimated using enthalpy data and equilibrium constant, K_p data.

Analysis For this problem we use enthalpy and Gibbs function properties from EES.

The K_p value of a reaction at a specified temperature can be determined from the Gibbs function data using

$$K_p = e^{-\Delta G^*(T)/R_u T} \quad \text{or} \quad \ln K_p = -\Delta G^*(T)/R_u T$$

where

$$\Delta G^*(T) = \nu_{\text{CO}_2} \bar{g}_{\text{CO}_2}^*(T) + \nu_{\text{H}_2\text{O}} \bar{g}_{\text{H}_2\text{O}}^*(T) - \nu_{\text{CH}_4} \bar{g}_{\text{CH}_4}^*(T) - \nu_{\text{O}_2} \bar{g}_{\text{O}_2}^*(T)$$

At $T_1 = 2500 - 10 = 2490$ K:

$$\begin{aligned} \Delta G_1^*(T) &= \nu_{\text{CO}_2} \bar{g}_{\text{CO}_2}^*(T_1) + \nu_{\text{H}_2\text{O}} \bar{g}_{\text{H}_2\text{O}}^*(T_1) - \nu_{\text{CH}_4} \bar{g}_{\text{CH}_4}^*(T_1) - \nu_{\text{O}_2} \bar{g}_{\text{O}_2}^*(T_1) \\ &= 1(-1,075,278) + 2(-831,031) - 1(-722,303) - 2(-611,914) \\ &= -791,208 \text{ kJ/kmol} \end{aligned}$$

At $T_2 = 2500 + 10 = 2510$ K:

$$\begin{aligned} \Delta G_2^*(T) &= \nu_{\text{CO}_2} \bar{g}_{\text{CO}_2}^*(T_2) + \nu_{\text{H}_2\text{O}} \bar{g}_{\text{H}_2\text{O}}^*(T_2) - \nu_{\text{CH}_4} \bar{g}_{\text{CH}_4}^*(T_2) - \nu_{\text{O}_2} \bar{g}_{\text{O}_2}^*(T_2) \\ &= 1(-1,081,734) + 2(-836,564) - 1(-728,962) - 2(-617,459) \\ &= -790,981 \text{ kJ/kmol} \end{aligned}$$

The Gibbs functions are obtained from enthalpy and entropy properties using EES. Substituting,

$$K_{p1} = \exp\left(-\frac{-791,208 \text{ kJ/kmol}}{(8.314 \text{ kJ/kmol} \cdot \text{K})(2490 \text{ K})}\right) = 3.966 \times 10^{16}$$

$$K_{p2} = \exp\left(-\frac{-790,981 \text{ kJ/kmol}}{(8.314 \text{ kJ/kmol} \cdot \text{K})(2510 \text{ K})}\right) = 2.893 \times 10^{16}$$

The enthalpy of reaction is determined by using the integrated van't Hoff equation:

$$\begin{aligned} \ln\left(\frac{K_{p2}}{K_{p1}}\right) &= \frac{\bar{h}_R}{R_u} \left(\frac{1}{T_1} - \frac{1}{T_2}\right) \\ \ln\left(\frac{2.893 \times 10^{16}}{3.966 \times 10^{16}}\right) &= \frac{\bar{h}_R}{8.314 \text{ kJ/kmol} \cdot \text{K}} \left(\frac{1}{2490 \text{ K}} - \frac{1}{2510 \text{ K}}\right) \longrightarrow \bar{h}_R = \mathbf{-819,472 \text{ kJ/kmol}} \end{aligned}$$

The enthalpy of reaction can also be determined from an energy balance to be

$$\bar{h}_R = H_P - H_R$$

where

$$H_R = 1\bar{h}_{\text{CH}_4 @ 2500\text{K}} + 2\bar{h}_{\text{O}_2 @ 2500\text{K}} = 106,833 + 2(78,437) = 263,708 \text{ kJ/kmol}$$

$$H_P = 1\bar{h}_{\text{CO}_2 @ 2500\text{K}} + 2\bar{h}_{\text{H}_2\text{O} @ 2500\text{K}} = (-271,531) + 2(-142,117) = -555,765 \text{ kJ/kmol}$$

The enthalpies are obtained from EES. Substituting,

$$\bar{h}_R = H_P - H_R = (-555,765) - (263,708) = \mathbf{-819,472 \text{ kJ/kmol}}$$

which is identical to the value obtained using K_p data.

The EES code for the solution of this problem is given next:

"The reaction temperature is:"

T_reac= 2500 [K]

DELTA T=10 [K]

$$R_u=8.314 \text{ [kJ/kmol-K]}$$

"The assumed equilibrium reaction is $\text{CH}_4 + 2 \text{O}_2 = \text{CO}_2 + 2 \text{H}_2\text{O}$ "

"The following equations provide the specific Gibbs function ($g=h-Ts$) for each component in the product gases as a function of its temperature, T_{reac} , at 1 atm pressure, 101.3 kPa"

"First find K_{P_1} at T_{mDT} "

$$T_{mDT}=T_{\text{reac}}-\text{DELTA}T \text{ [K]}$$

$$g_{\text{CO}_2_1}=\text{Enthalpy}(\text{CO}_2, T=T_{mDT})-(T_{mDT}) * \text{Entropy}(\text{CO}_2, T=T_{mDT}, P=101.3)$$

$$g_{\text{O}_2_1}=\text{Enthalpy}(\text{O}_2, T=T_{mDT})-(T_{mDT}) * \text{Entropy}(\text{O}_2, T=T_{mDT}, P=101.3)$$

$$g_{\text{CH}_4_1}=\text{Enthalpy}(\text{CH}_4, T=T_{mDT})-(T_{mDT}) * \text{Entropy}(\text{CH}_4, T=T_{mDT}, P=101.3)$$

$$g_{\text{H}_2\text{O}_1}=\text{Enthalpy}(\text{H}_2\text{O}, T=T_{mDT})-(T_{mDT}) * \text{Entropy}(\text{H}_2\text{O}, T=T_{mDT}, P=101.3)$$

"The standard-state Gibbs function is"

$$\text{DELTA}G_1 = 1 * g_{\text{CO}_2_1} + 2 * g_{\text{H}_2\text{O}_1} - 1 * g_{\text{CH}_4_1} - 2 * g_{\text{O}_2_1}$$

"The equilibrium constant is given by Eq. 15-14."

$$K_{P_1} = \exp(-\text{DELTA}G_1 / (R_u * T_{mDT}))$$

"Second find K_{P_2} at T_{pDT} "

$$T_{pDT}=T_{\text{reac}}+\text{DELTA}T$$

$$g_{\text{CO}_2_2}=\text{Enthalpy}(\text{CO}_2, T=T_{pDT})-(T_{pDT}) * \text{Entropy}(\text{CO}_2, T=T_{pDT}, P=101.3)$$

$$g_{\text{O}_2_2}=\text{Enthalpy}(\text{O}_2, T=T_{pDT})-(T_{pDT}) * \text{Entropy}(\text{O}_2, T=T_{pDT}, P=101.3)$$

$$g_{\text{CH}_4_2}=\text{Enthalpy}(\text{CH}_4, T=T_{pDT})-(T_{pDT}) * \text{Entropy}(\text{CH}_4, T=T_{pDT}, P=101.3)$$

$$g_{\text{H}_2\text{O}_2}=\text{Enthalpy}(\text{H}_2\text{O}, T=T_{pDT})-(T_{pDT}) * \text{Entropy}(\text{H}_2\text{O}, T=T_{pDT}, P=101.3)$$

"The standard-state Gibbs function is"

$$\text{DELTA}G_2 = 1 * g_{\text{CO}_2_2} + 2 * g_{\text{H}_2\text{O}_2} - 1 * g_{\text{CH}_4_2} - 2 * g_{\text{O}_2_2}$$

"The equilibrium constant is given by Eq. 15-14."

$$K_{P_2} = \exp(-\text{DELTA}G_2 / (R_u * T_{pDT}))$$

"Estimate the enthalpy of reaction by using the integrated van't Hoff equation."

$$\ln(K_{P_2}/K_{P_1})=h_{\text{bar}}R_{kp}/R_u*(1/(T_{mDT})-1/(T_{pDT}))$$

"The enthalpy of reaction is obtained from the energy balance:"

$$h_{\text{bar}}R_{\text{eng}} = H_P - H_R$$

$$H_R = 1 * h_{\text{CH}_4} + 2 * h_{\text{O}_2}$$

$$H_P = 1 * h_{\text{CO}_2} + 2 * h_{\text{H}_2\text{O}}$$

$$h_{\text{CH}_4} = \text{ENTHALPY}(\text{CH}_4, T=T_{\text{reac}})$$

$$h_{\text{O}_2} = \text{ENTHALPY}(\text{O}_2, T=T_{\text{reac}})$$

$$h_{\text{CO}_2} = \text{ENTHALPY}(\text{CO}_2, T=T_{\text{reac}})$$

$$h_{\text{H}_2\text{O}} = \text{ENTHALPY}(\text{H}_2\text{O}, T=T_{\text{reac}})$$

SOLUTION

Variables in Main

$$\text{DELTA}G_1 = -791208 \text{ [kJ/kmol]}$$

$$\text{DELTA}T = 10 \text{ [K]}$$

$$g_{\text{CH}_4_2} = -728962 \text{ [kJ/kmol]}$$

$$g_{\text{CO}_2_2} = -1081734 \text{ [kJ/kmol]}$$

$$g_{\text{H}_2\text{O}_2} = -836564 \text{ [kJ/kmol]}$$

$$g_{\text{O}_2_2} = -617459 \text{ [kJ/kmol]}$$

$$h_{\text{bar}}R_{kp} = -819472 \text{ [kJ/kmol]}$$

$$h_{\text{CO}_2} = -271531 \text{ [kJ/kmol]}$$

$$h_{\text{O}_2} = 78437 \text{ [kJ/kmol]}$$

$$H_R = 263708 \text{ [kJ/kmol]}$$

$$K_{P_2} = 2.893E+16$$

$$T_{mDT} = 2490 \text{ [K]}$$

$$T_{\text{reac}} = 2500 \text{ [K]}$$

$$\text{DELTA}G_2 = -790981 \text{ [kJ/kmol]}$$

$$g_{\text{CH}_4_1} = -722303 \text{ [kJ/kmol]}$$

$$g_{\text{CO}_2_1} = -1075278 \text{ [kJ/kmol]}$$

$$g_{\text{H}_2\text{O}_1} = -831031 \text{ [kJ/kmol]}$$

$$g_{\text{O}_2_1} = -611914 \text{ [kJ/kmol]}$$

$$h_{\text{bar}}R_{\text{eng}} = -819472 \text{ [kJ/kmol]}$$

$$h_{\text{CH}_4} = 106833 \text{ [kJ/kmol]}$$

$$h_{\text{H}_2\text{O}} = -142117 \text{ [kJ/kmol]}$$

$$H_P = -555765 \text{ [kJ/kmol]}$$

$$K_{P_1} = 3.966E+16$$

$$R_u = 8.314 \text{ [kJ/kmol-K]}$$

$$T_{pDT} = 2510 \text{ [K]}$$

Phase Equilibrium

16-59C No. Because the specific gibbs function of each phase will not be affected by this process; i.e., we will still have $g_f = g_g$.

16-60C Yes. Because the number of independent variables for a two-phase (PH=2), two-component (C=2) mixture is, from the phase rule,

$$IV = C - PH + 2 = 2 - 2 + 2 = 2$$

Therefore, two properties can be changed independently for this mixture. In other words, we can hold the temperature constant and vary the pressure and still be in the two-phase region. Notice that if we had a single component (C=1) two phase system, we would have IV=1, which means that fixing one independent property automatically fixes all the other properties.

11-61C Using solubility data of a solid in a specified liquid, the mass fraction w of the solid A in the liquid at the interface at a specified temperature can be determined from

$$\text{mf}_A = \frac{m_{\text{solid}}}{m_{\text{solid}} + m_{\text{liquid}}}$$

where m_{solid} is the maximum amount of solid dissolved in the liquid of mass m_{liquid} at the specified temperature.

11-62C The molar concentration C_i of the gas species i in the solid at the interface $C_{i, \text{solid side}}(0)$ is proportional to the *partial pressure* of the species i in the gas $P_{i, \text{gas side}}(0)$ on the gas side of the interface, and is determined from

$$C_{i, \text{solid side}}(0) = S \times P_{i, \text{gas side}}(0) \quad (\text{kmol/m}^3)$$

where S is the *solubility* of the gas in that solid at the specified temperature.

11-63C Using Henry's constant data for a gas dissolved in a liquid, the mole fraction of the gas dissolved in the liquid at the interface at a specified temperature can be determined from Henry's law expressed as

$$y_{i, \text{liquid side}}(0) = \frac{P_{i, \text{gas side}}(0)}{H}$$

where H is *Henry's constant* and $P_{i, \text{gas side}}(0)$ is the partial pressure of the gas i at the gas side of the interface. This relation is applicable for dilute solutions (gases that are weakly soluble in liquids).

16-64E The maximum partial pressure of the water evaporated into the air as it emerges from a porous media is to be determined.

Assumptions The air and water-air solution behave as ideal solutions so that Raoult's law may be used.

Analysis The saturation temperature of water at 70°F is

$$P_{\text{sat}@70^\circ\text{F}} = 0.36334 \text{ psia}$$

Since the mole fraction of the air in the liquid water is essentially zero,

$$P_{v,\text{max}} = 1 \times P_{\text{sat}@70^\circ\text{F}} = \mathbf{0.36334 \text{ psia}}$$

16-65E Water is sprayed into air, and the falling water droplets are collected in a container. The mass and mole fractions of air dissolved in the water are to be determined.

Assumptions 1 Both the air and water vapor are ideal gases. **2** Air is saturated since water is constantly sprayed into it. **3** Air is weakly soluble in water and thus Henry's law is applicable.

Properties The saturation pressure of water at 80°F is 0.5075 psia (Table A-4E). Henry's constant for air dissolved in water at 80°F (300 K) is given in Table 16-2 to be $H = 74,000 \text{ bar}$. Molar masses of dry air and water are 29 and 18 lbm / lbmol, respectively (Table A-1).

Analysis Noting that air is saturated, the partial pressure of water vapor

in the air will simply be the saturation pressure of water at 80°F,

$$P_{\text{vapor}} = P_{\text{sat}@80^\circ\text{F}} = 0.5075 \text{ psia}$$

Then the partial pressure of dry air becomes

$$P_{\text{dry air}} = P - P_{\text{vapor}} = 14.3 - 0.5075 = 13.793 \text{ psia}$$

From Henry's law, the mole fraction of air in the water is determined to be

$$y_{\text{dry air, liquid side}} = \frac{P_{\text{dry air, gasside}}}{H} = \frac{13.793 \text{ psia} (1 \text{ atm} / 14.696 \text{ psia})}{74,000 \text{ bar} (1 \text{ atm} / 1.01325 \text{ bar})} = \mathbf{1.29 \times 10^{-5}}$$

which is very small, as expected.

The mass and mole fractions of a mixture are related to each other by

$$\text{mf}_i = \frac{m_i}{m_m} = \frac{N_i M_i}{N_m M_m} = y_i \frac{M_i}{M_m}$$

where the apparent molar mass of the liquid water - air mixture is

$$\begin{aligned} M_m &= \sum y_i M_i = y_{\text{liquid water}} M_{\text{water}} + y_{\text{dry air}} M_{\text{dry air}} \\ &\cong 1 \times 18.0 + 0 \times 29.0 \cong 18.0 \text{ kg/kmol} \end{aligned}$$

Then the mass fraction of dissolved air in liquid water becomes

$$\text{mf}_{\text{dry air, liquid side}} = y_{\text{dry air, liquid side}} \frac{M_{\text{dry air}}}{M_m} = (1.29 \times 10^{-5}) \frac{29}{18} = \mathbf{2.08 \times 10^{-5}}$$

16-66 It is to be shown that a saturated liquid-vapor mixture of refrigerant-134a at -10°C satisfies the criterion for phase equilibrium.

Analysis Using the definition of Gibbs function and enthalpy and entropy data from Table A-11,

$$g_f = h_f - Ts_f = (38.53 \text{ kJ/kg}) - (263.15 \text{ K})(0.15496 \text{ kJ/kg} \cdot \text{K}) = -2.248 \text{ kJ/kg}$$

$$g_g = h_g - Ts_g = (244.55 \text{ kJ/kg}) - (263.15 \text{ K})(0.93782 \text{ kJ/kg} \cdot \text{K}) = -2.234 \text{ kJ/kg}$$

which are sufficiently close. Therefore, the criterion for phase equilibrium is satisfied.

16-67 It is to be shown that a mixture of saturated liquid water and saturated water vapor at 300 kPa satisfies the criterion for phase equilibrium.

Analysis The saturation temperature at 300 kPa is 406.7 K. Using the definition of Gibbs function and enthalpy and entropy data from Table A-5,

$$g_f = h_f - Ts_f = (561.43 \text{ kJ/kg}) - (406.7 \text{ K})(1.6717 \text{ kJ/kg} \cdot \text{K}) = -118.5 \text{ kJ/kg}$$

$$g_g = h_g - Ts_g = (2724.9 \text{ kJ/kg}) - (406.7 \text{ K})(6.9917 \text{ kJ/kg} \cdot \text{K}) = -118.6 \text{ kJ/kg}$$

which are practically same. Therefore, the criterion for phase equilibrium is satisfied.

16-68 The values of the Gibbs function for saturated refrigerant-134a at 280 kPa are to be calculated.

Analysis The saturation temperature of R-134a at 280 kPa is -1.25°C (Table A-12). Obtaining other properties from Table A-12, the Gibbs function for the liquid phase is,

$$g_f = h_f - Ts_f = 50.16 \text{ kJ/kg} - (-1.25 + 273.15 \text{ K})(0.19822 \text{ kJ/kg} \cdot \text{K}) = \mathbf{-3.735 \text{ kJ/kg}}$$

For the vapor phase,

$$g_g = h_g - Ts_g = 249.77 \text{ kJ/kg} - (-1.25 + 273.15 \text{ K})(0.93228 \text{ kJ/kg} \cdot \text{K}) = \mathbf{-3.721 \text{ kJ/kg}}$$

The results agree and demonstrate that phase equilibrium exists.

R-134a 280 kPa $x = 0.70$

16-69E The values of the Gibbs function for saturated steam at 500°F as a saturated liquid, saturated vapor, and a mixture of liquid and vapor are to be calculated.

Analysis Obtaining properties from Table A-4E, the Gibbs function for the liquid phase is,

$$g_f = h_f - Ts_f = 487.89 \text{ Btu/lbm} - (959.67 \text{ R})(0.6890 \text{ Btu/lbm} \cdot \text{R}) = \mathbf{-173.3 \text{ Btu/lbm}}$$

For the vapor phase,

$$g_g = h_g - Ts_g = 1202.3 \text{ Btu/lbm} - (959.67 \text{ R})(1.4334 \text{ Btu/lbm} \cdot \text{R}) = \mathbf{-173.3 \text{ Btu/lbm}}$$

For the saturated mixture with a quality of 40%,

$$h = h_f + xh_{fg} = 487.89 \text{ Btu/lbm} + (0.40)(714.44 \text{ Btu/lbm}) = 773.67 \text{ Btu/lbm}$$

$$s = s_f + xs_{fg} = 0.6890 \text{ Btu/lbm} \cdot \text{R} + (0.40)(0.7445 \text{ Btu/lbm} \cdot \text{R}) = 0.9868 \text{ Btu/lbm} \cdot \text{R}$$

$$g = h - Ts = 773.67 \text{ Btu/lbm} - (959.67 \text{ R})(0.9868 \text{ Btu/lbm} \cdot \text{R}) = \mathbf{-173.3 \text{ Btu/lbm}}$$

The results agree and demonstrate that phase equilibrium exists.

Steam
500°F

16-70 A liquid-vapor mixture of ammonia and water in equilibrium at a specified temperature is considered. The pressure of ammonia is to be determined for two compositions of the liquid phase.

Assumptions The mixture is ideal and thus Raoult's law is applicable.

Analysis According to Raoult's law, when the mole fraction of the ammonia liquid is 20%,

$$P_{\text{NH}_3} = y_{f,\text{NH}_3} P_{\text{sat},\text{NH}_3}(T) = 0.20(615.3 \text{ kPa}) = \mathbf{123.1 \text{ kPa}}$$

When the mole fraction of the ammonia liquid is 80%,

$$P_{\text{NH}_3} = y_{f,\text{NH}_3} P_{\text{sat},\text{NH}_3}(T) = 0.80(615.3 \text{ kPa}) = \mathbf{492.2 \text{ kPa}}$$

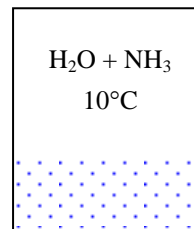

16-71 Using the liquid-vapor equilibrium diagram of an oxygen-nitrogen mixture, the composition of each phase at a specified temperature and pressure is to be determined.

Analysis From the equilibrium diagram (Fig. 16-21) we read

Liquid: 30% N₂ and 70% O₂

Vapor: 67% N₂ and 33% O₂

16-72 Using the liquid-vapor equilibrium diagram of an oxygen-nitrogen mixture at a specified pressure, the temperature is to be determined for a specified composition of the vapor phase.

Analysis From the equilibrium diagram (Fig. 16-21) we read

$$T = \mathbf{82 \text{ K.}}$$

16-73 Using the liquid-vapor equilibrium diagram of an oxygen-nitrogen mixture at a specified pressure, the mass of the oxygen in the liquid and gaseous phases is to be determined for a specified composition of the mixture.

Properties The molar masses of O_2 is 32 kg/kmol and that of N_2 is 28 kg/kmol (Table A-1).

Analysis From the equilibrium diagram (Fig. 16-21) at $T = 84$ K, the oxygen mole fraction in the vapor phase is 34% and that in the liquid phase is 70%. That is,

$$y_{f,O_2} = 0.70 \quad \text{and} \quad y_{g,O_2} = 0.34$$

The mole numbers are

$$N_{O_2} = \frac{m_{O_2}}{M_{O_2}} = \frac{30 \text{ kg}}{32 \text{ kg/kmol}} = 0.9375 \text{ kmol}$$

$$N_{N_2} = \frac{m_{N_2}}{M_{N_2}} = \frac{40 \text{ kg}}{28 \text{ kg/kmol}} = 1.429 \text{ kmol}$$

$$N_{\text{total}} = 0.9375 + 1.429 = 2.366 \text{ kmol}$$

The total number of moles in this system is

$$N_f + N_g = 2.366 \quad (1)$$

The total number of moles of oxygen in this system is

$$0.7N_f + 0.34N_g = 0.9375 \quad (2)$$

Solving equations (1) and (2) simultaneously, we obtain

$$N_f = 0.3696$$

$$N_g = 1.996$$

Then, the mass of oxygen in the liquid and vapor phases is

$$m_{f,O_2} = y_{f,O_2} N_f M_{O_2} = (0.7)(0.3696 \text{ kmol})(32 \text{ kg/kmol}) = \mathbf{8.28 \text{ kg}}$$

$$m_{g,O_2} = y_{g,O_2} N_g M_{O_2} = (0.34)(1.996 \text{ kmol})(32 \text{ kg/kmol}) = \mathbf{21.72 \text{ kg}}$$

16-74 Using the liquid-vapor equilibrium diagram of an oxygen-nitrogen mixture at a specified pressure, the total mass of the liquid phase is to be determined.

Properties The molar masses of O_2 is 32 kg/kmol and that of N_2 is 28 kg/kmol (Table A-1).

Analysis From the equilibrium diagram (Fig. 16-21) at $T = 84$ K, the oxygen mole fraction in the vapor phase is 34% and that in the liquid phase is 70%. That is,

$$y_{f,O_2} = 0.70 \quad \text{and} \quad y_{g,O_2} = 0.34$$

Also,

$$y_{f,N_2} = 0.30 \quad \text{and} \quad y_{g,N_2} = 0.66$$

The mole numbers are

$$N_{O_2} = \frac{m_{O_2}}{M_{O_2}} = \frac{30 \text{ kg}}{32 \text{ kg/kmol}} = 0.9375 \text{ kmol}$$

$$N_{N_2} = \frac{m_{N_2}}{M_{N_2}} = \frac{40 \text{ kg}}{28 \text{ kg/kmol}} = 1.429 \text{ kmol}$$

$$N_{\text{total}} = 0.9375 + 1.429 = 2.366 \text{ kmol}$$

The total number of moles in this system is

$$N_f + N_g = 2.366 \quad (1)$$

The total number of moles of oxygen in this system is

$$0.7N_f + 0.34N_g = 0.9375 \quad (2)$$

Solving equations (1) and (2) simultaneously, we obtain

$$N_f = 0.3696$$

$$N_g = 1.996$$

The total mass of liquid in the mixture is then

$$\begin{aligned} m_{f,\text{total}} &= m_{f,O_2} + m_{f,N_2} \\ &= y_{f,O_2} N_f M_{O_2} + y_{f,N_2} N_f M_{N_2} \\ &= (0.7)(0.3696 \text{ kmol})(32 \text{ kg/kmol}) + (0.3)(0.3696 \text{ kmol})(28 \text{ kg/kmol}) \\ &= \mathbf{11.38 \text{ kg}} \end{aligned}$$

16-75 A rubber wall separates O_2 and N_2 gases. The molar concentrations of O_2 and N_2 in the wall are to be determined.

Assumptions The O_2 and N_2 gases are in phase equilibrium with the rubber wall.

Properties The molar mass of oxygen and nitrogen are 32.0 and 28.0 kg/kmol, respectively (Table A-1). The solubility of oxygen and nitrogen in rubber at 298 K are 0.00312 and 0.00156 kmol/m³·bar, respectively (Table 16-3).

Analysis Noting that 500 kPa = 5 bar, the molar densities of oxygen and nitrogen in the rubber wall are determined to be

$$\begin{aligned} C_{O_2, \text{solidside}}(0) &= S \times P_{O_2, \text{gasside}} \\ &= (0.00312 \text{ kmol/m}^3 \cdot \text{bar})(5 \text{ bar}) \\ &= \mathbf{0.0156 \text{ kmol/m}^3} \end{aligned}$$

$$\begin{aligned} C_{N_2, \text{solidside}}(0) &= S \times P_{N_2, \text{gasside}} \\ &= (0.00156 \text{ kmol/m}^3 \cdot \text{bar})(5 \text{ bar}) \\ &= \mathbf{0.00780 \text{ kmol/m}^3} \end{aligned}$$

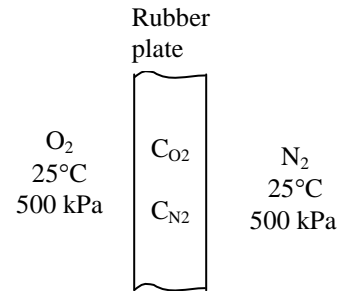

That is, there will be 0.0156 kmol of O_2 and 0.00780 kmol of N_2 gas in each m³ volume of the rubber wall.

16-76 A rubber plate is exposed to nitrogen. The molar and mass density of nitrogen in the iron at the interface is to be determined.

Assumptions Rubber and nitrogen are in thermodynamic equilibrium at the interface.

Properties The molar mass of nitrogen is $M = 28.0$ kg/kmol (Table A-1). The solubility of nitrogen in rubber at 298 K is 0.00156 kmol/m³·bar (Table 16-3).

Analysis Noting that 250 kPa = 2.5 bar, the molar density of nitrogen in the rubber at the interface is determined to be

$$\begin{aligned} C_{N_2, \text{solidside}}(0) &= S \times P_{N_2, \text{gasside}} \\ &= (0.00156 \text{ kmol/m}^3 \cdot \text{bar})(2.5 \text{ bar}) \\ &= \mathbf{0.0039 \text{ kmol/m}^3} \end{aligned}$$

It corresponds to a mass density of

$$\begin{aligned} \rho_{N_2, \text{solidside}}(0) &= C_{N_2, \text{solidside}}(0) M_{N_2} \\ &= (0.0039 \text{ kmol/m}^3)(28 \text{ kg/kmol}) \\ &= \mathbf{0.1092 \text{ kg/m}^3} \end{aligned}$$

That is, there will be 0.0039 kmol (or 0.1092 kg) of N_2 gas in each m³ volume of iron adjacent to the interface.

16-77 A liquid-vapor mixture of ammonia and water in equilibrium at a specified temperature is considered. The composition of the liquid phase is given. The composition of the vapor phase is to be determined.

Assumptions The mixture is ideal and thus Raoult's law is applicable.

Properties At 30°C, $P_{\text{sat,H}_2\text{O}} = 4.247 \text{ kPa}$ and $P_{\text{sat,NH}_3} = 1167.4 \text{ kPa}$.

Analysis The vapor pressures are

$$P_{\text{H}_2\text{O}} = y_{f,\text{H}_2\text{O}} P_{\text{sat,H}_2\text{O}}(T) = 0.40(4.247 \text{ kPa}) = 1.70 \text{ kPa}$$

$$P_{\text{NH}_3} = y_{f,\text{NH}_3} P_{\text{sat,NH}_3}(T) = 0.60(1167.4 \text{ kPa}) = 700.44 \text{ kPa}$$

Thus the total pressure of the mixture is

$$P_{\text{total}} = P_{\text{H}_2\text{O}} + P_{\text{NH}_3} = (1.70 + 700.44) \text{ kPa} = 702.1 \text{ kPa}$$

Then the mole fractions in the vapor phase become

$$y_{g,\text{H}_2\text{O}} = \frac{P_{\text{H}_2\text{O}}}{P_{\text{total}}} = \frac{1.70 \text{ kPa}}{702.1 \text{ kPa}} = \mathbf{0.0024} \text{ or } 0.24\%$$

$$y_{g,\text{NH}_3} = \frac{P_{\text{NH}_3}}{P_{\text{total}}} = \frac{700.44 \text{ kPa}}{702.1 \text{ kPa}} = \mathbf{0.9976} \text{ or } 99.76\%$$

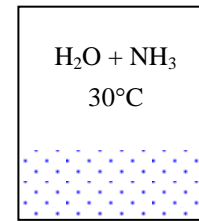

16-78 An ammonia-water absorption refrigeration unit is considered. The operating pressures in the generator and absorber, and the mole fractions of the ammonia in the strong liquid mixture being pumped from the absorber and the weak liquid solution being drained from the generator are to be determined.

Assumptions The mixture is ideal and thus Raoult's law is applicable.

Properties At 0°C, $P_{\text{sat,H}_2\text{O}} = 0.6112 \text{ kPa}$ and at 46°C, $P_{\text{sat,H}_2\text{O}} = 10.10 \text{ kPa}$ (Table A-4). The saturation pressures of ammonia at the same temperatures are given to be 430.6 kPa and 1830.2 kPa, respectively.

Analysis According to Raoult's law, the partial pressures of ammonia and water are given by

$$P_{g,\text{NH}_3} = y_{f,\text{NH}_3} P_{\text{sat,NH}_3}$$

$$P_{g,\text{H}_2\text{O}} = y_{f,\text{H}_2\text{O}} P_{\text{sat,H}_2\text{O}} = (1 - y_{f,\text{NH}_3}) P_{\text{sat,H}_2\text{O}}$$

Using Dalton's partial pressure model for ideal gas mixtures, the mole fraction of the ammonia in the vapor mixture is

$$y_{g,\text{NH}_3} = \frac{y_{f,\text{NH}_3} P_{\text{sat,NH}_3}}{y_{f,\text{NH}_3} P_{\text{sat,NH}_3} + (1 - y_{f,\text{NH}_3}) P_{\text{sat,H}_2\text{O}}}$$

$$0.96 = \frac{430.6 y_{f,\text{NH}_3}}{430.6 y_{f,\text{NH}_3} + 0.6112(1 - y_{f,\text{NH}_3})} \longrightarrow y_{f,\text{NH}_3} = \mathbf{0.03294}$$

Then,

$$P = y_{f,\text{NH}_3} P_{\text{sat,NH}_3} + (1 - y_{f,\text{NH}_3}) P_{\text{sat,H}_2\text{O}}$$

$$= (0.03294)(430.6) + (1 - 0.03294)(0.6112) = \mathbf{14.78 \text{ kPa}}$$

Performing the similar calculations for the regenerator,

$$0.96 = \frac{1830.2 y_{f,\text{NH}_3}}{1830.2 y_{f,\text{NH}_3} + 10.10(1 - y_{f,\text{NH}_3})} \longrightarrow y_{f,\text{NH}_3} = \mathbf{0.1170}$$

$$P = (0.1170)(1830.2) + (1 - 0.1170)(10.10) = \mathbf{223.1 \text{ kPa}}$$

16-79 An ammonia-water absorption refrigeration unit is considered. The operating pressures in the generator and absorber, and the mole fractions of the ammonia in the strong liquid mixture being pumped from the absorber and the weak liquid solution being drained from the generator are to be determined.

Assumptions The mixture is ideal and thus Raoult's law is applicable.

Properties At 6°C, $P_{\text{sat,H}_2\text{O}} = 0.9353 \text{ kPa}$ and at 40°C, $P_{\text{sat,H}_2\text{O}} = 7.3851 \text{ kPa}$ (Table A-4 or EES). The saturation pressures of ammonia at the same temperatures are given to be 534.8 kPa and 1556.7 kPa, respectively.

Analysis According to Raoult's law, the partial pressures of ammonia and water are given by

$$P_{\text{g,NH}_3} = y_{f,\text{NH}_3} P_{\text{sat,NH}_3}$$

$$P_{\text{g,H}_2\text{O}} = y_{f,\text{H}_2\text{O}} P_{\text{sat,H}_2\text{O}} = (1 - y_{f,\text{NH}_3}) P_{\text{sat,H}_2\text{O}}$$

Using Dalton's partial pressure model for ideal gas mixtures, the mole fraction of the ammonia in the vapor mixture is

$$y_{\text{g,NH}_3} = \frac{y_{f,\text{NH}_3} P_{\text{sat,NH}_3}}{y_{f,\text{NH}_3} P_{\text{sat,NH}_3} + (1 - y_{f,\text{NH}_3}) P_{\text{sat,H}_2\text{O}}}$$

$$0.96 = \frac{534.8 y_{f,\text{NH}_3}}{534.8 y_{f,\text{NH}_3} + 0.9353(1 - y_{f,\text{NH}_3})} \longrightarrow y_{f,\text{NH}_3} = \mathbf{0.04028}$$

Then,

$$P = y_{f,\text{NH}_3} P_{\text{sat,NH}_3} + (1 - y_{f,\text{NH}_3}) P_{\text{sat,H}_2\text{O}}$$

$$= (0.04028)(534.8) + (1 - 0.04028)(0.9353) = \mathbf{22.44 \text{ kPa}}$$

Performing the similar calculations for the regenerator,

$$0.96 = \frac{1556.7 y_{f,\text{NH}_3}}{1556.7 y_{f,\text{NH}_3} + 7.3851(1 - y_{f,\text{NH}_3})} \longrightarrow y_{f,\text{NH}_3} = \mathbf{0.1022}$$

$$P = (0.1022)(1556.7) + (1 - 0.1022)(7.3851) = \mathbf{165.7 \text{ kPa}}$$

16-80 A liquid mixture of water and R-134a is considered. The mole fraction of the water and R-134a vapor are to be determined.

Assumptions The mixture is ideal and thus Raoult's law is applicable.

Properties At 20°C, $P_{\text{sat,H}_2\text{O}} = 2.3392 \text{ kPa}$ and $P_{\text{sat,R}} = 572.07 \text{ kPa}$ (Tables A-4, A-11). The molar masses of water and R-134a are 18.015 and 102.03 kg/kmol, respectively (Table A-1).

Analysis The mole fraction of the water in the liquid mixture is

$$y_{f,\text{H}_2\text{O}} = \frac{N_{f,\text{H}_2\text{O}}}{N_{\text{total}}} = \frac{\text{mf}_{f,\text{H}_2\text{O}} / M_{\text{H}_2\text{O}}}{(\text{mf}_{f,\text{H}_2\text{O}} / M_{\text{H}_2\text{O}}) + (\text{mf}_{f,\text{R}} / M_{\text{R}})}$$

$$= \frac{0.9 / 18.015}{(0.9 / 18.015) + (0.1 / 102.03)} = 0.9808$$

<p>H₂O + R-134a 20°C</p>

According to Raoult's law, the partial pressures of R-134a and water in the vapor mixture are

$$P_{g,\text{R}} = y_{f,\text{R}} P_{\text{sat,R}} = (1 - 0.9808)(572.07 \text{ kPa}) = 10.98 \text{ kPa}$$

$$P_{g,\text{H}_2\text{O}} = y_{f,\text{H}_2\text{O}} P_{\text{sat,H}_2\text{O}} = (0.9808)(2.3392 \text{ kPa}) = 2.294 \text{ kPa}$$

The total pressure of the vapor mixture is then

$$P_{\text{total}} = P_{g,\text{R}} + P_{g,\text{H}_2\text{O}} = 10.98 + 2.294 = 13.274 \text{ kPa}$$

Based on Dalton's partial pressure model for ideal gases, the mole fractions in the vapor phase are

$$y_{g,\text{H}_2\text{O}} = \frac{P_{g,\text{H}_2\text{O}}}{P_{\text{total}}} = \frac{2.294 \text{ kPa}}{13.274 \text{ kPa}} = \mathbf{0.1728}$$

$$y_{g,\text{R}} = \frac{P_{g,\text{R}}}{P_{\text{total}}} = \frac{10.98 \text{ kPa}}{13.274 \text{ kPa}} = \mathbf{0.8272}$$

16-81 A glass of water is left in a room. The mole fraction of the water vapor in the air and the mole fraction of air in the water are to be determined when the water and the air are in thermal and phase equilibrium.

Assumptions **1** Both the air and water vapor are ideal gases. **2** Air is saturated since the humidity is 100 percent. **3** Air is weakly soluble in water and thus Henry's law is applicable.

Properties The saturation pressure of water at 27°C is 3.568 kPa (Table A-4). Henry's constant for air dissolved in water at 27°C (300 K) is given in Table 16-2 to be $H = 74,000$ bar. Molar masses of dry air and water are 29 and 18 kg/kmol, respectively (Table A-1).

Analysis (a) Noting that air is saturated, the partial pressure of water vapor in the air will simply be the saturation pressure of water at 27°C,

$$P_{\text{vapor}} = P_{\text{sat @ 27°C}} = 3.568 \text{ kPa} \quad (\text{Table A-4 or EES})$$

Assuming both the air and vapor to be ideal gases, the mole fraction of water vapor in the air is determined to be

$$y_{\text{vapor}} = \frac{P_{\text{vapor}}}{P} = \frac{3.568 \text{ kPa}}{97 \text{ kPa}} = \mathbf{0.0368}$$

(b) Noting that the total pressure is 97 kPa, the partial pressure of dry air is

$$P_{\text{dry air}} = P - P_{\text{vapor}} = 97 - 3.568 = 93.43 \text{ kPa} = 0.9343 \text{ bar}$$

From Henry's law, the mole fraction of air in the water is determined to be

$$y_{\text{dry air, liquid side}} = \frac{P_{\text{dry air, gas side}}}{H} = \frac{0.9343 \text{ bar}}{74,000 \text{ bar}} = \mathbf{1.26 \times 10^{-5}}$$

Discussion The amount of air dissolved in water is very small, as expected.

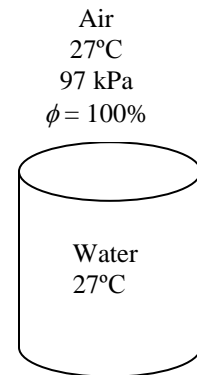

16-82 A carbonated drink in a bottle is considered. Assuming the gas space above the liquid consists of a saturated mixture of CO₂ and water vapor and treating the drink as a water, determine the mole fraction of the water vapor in the CO₂ gas and the mass of dissolved CO₂ in a 300 ml drink are to be determined when the water and the CO₂ gas are in thermal and phase equilibrium.

Assumptions 1 The liquid drink can be treated as water. **2** Both the CO₂ and the water vapor are ideal gases. **3** The CO₂ gas and water vapor in the bottle form a saturated mixture. **4** The CO₂ is weakly soluble in water and thus Henry's law is applicable.

Properties The saturation pressure of water at 27°C is 3.568 kPa (Table A-4). Henry's constant for CO₂ dissolved in water at 27°C (300 K) is given in Table 16-2 to be $H = 1710$ bar. Molar masses of CO₂ and water are 44 and 18 kg/kmol, respectively (Table A-1).

Analysis (a) Noting that the CO₂ gas in the bottle is saturated, the partial pressure of water vapor in the air will simply be the saturation pressure of water at 27°C,

$$P_{\text{vapor}} = P_{\text{sat @ 27°C}} = 3.568 \text{ kPa} \quad (\text{more accurate EES value compared to interpolation value from Table A-4})$$

Assuming both CO₂ and vapor to be ideal gases, the mole fraction of water vapor in the CO₂ gas becomes

$$y_{\text{vapor}} = \frac{P_{\text{vapor}}}{P} = \frac{3.568 \text{ kPa}}{115 \text{ kPa}} = \mathbf{0.0310}$$

(b) Noting that the total pressure is 115 kPa, the partial pressure of CO₂ is

$$P_{\text{CO}_2 \text{ gas}} = P - P_{\text{vapor}} = 115 - 3.568 = 111.4 \text{ kPa} = 1.114 \text{ bar}$$

From Henry's law, the mole fraction of CO₂ in the drink is determined to be

$$y_{\text{CO}_2, \text{liquid side}} = \frac{P_{\text{CO}_2 \text{ gas side}}}{H} = \frac{1.114 \text{ bar}}{1710 \text{ bar}} = \mathbf{6.52 \times 10^{-4}}$$

Then the mole fraction of water in the drink becomes

$$y_{\text{water, liquid side}} = 1 - y_{\text{CO}_2, \text{liquid side}} = 1 - 6.52 \times 10^{-4} = 0.9993$$

The mass and mole fractions of a mixture are related to each other by

$$mf_i = \frac{m_i}{m_m} = \frac{N_i M_i}{N_m M_m} = y_i \frac{M_i}{M_m}$$

where the apparent molar mass of the drink (liquid water - CO₂ mixture) is

$$M_m = \sum y_i M_i = y_{\text{liquid water}} M_{\text{water}} + y_{\text{CO}_2} M_{\text{CO}_2} = 0.9993 \times 18.0 + (6.52 \times 10^{-4}) \times 44 = 18.03 \text{ kg/kmol}$$

Then the mass fraction of dissolved CO₂ gas in liquid water becomes

$$mf_{\text{CO}_2, \text{liquid side}} = y_{\text{CO}_2, \text{liquid side}} \frac{M_{\text{CO}_2}}{M_m} = 6.52 \times 10^{-4} \frac{44}{18.03} = 0.00159$$

Therefore, the mass of dissolved CO₂ in a 300 ml \approx 300 g drink is

$$m_{\text{CO}_2} = mf_{\text{CO}_2} m_m = (0.00159)(300 \text{ g}) = \mathbf{0.477 \text{ g}}$$

Review Problems

16-83 The mole fraction of argon that ionizes at a specified temperature and pressure is to be determined.

Assumptions All components behave as ideal gases.

Analysis The stoichiometric and actual reactions can be written as

Stoichiometric: $\text{Ar} \Leftrightarrow \text{Ar}^+ + \text{e}^-$ (thus $\nu_{\text{Ar}} = 1$, $\nu_{\text{Ar}^+} = 1$ and $\nu_{\text{e}^-} = 1$)

Actual: $\text{Ar} \longrightarrow \underbrace{x\text{Ar}}_{\text{react.}} + \underbrace{y\text{Ar}^+ + ye^-}_{\text{products}}$

Ar balance: $1 = x + y$ or $y = 1 - x$

Total number of moles: $N_{\text{total}} = x + 2y = 2 - x$

The equilibrium constant relation becomes

$$K_p = \frac{N_{\text{Ar}}^{\nu_{\text{Ar}}} N_{\text{e}^-}^{\nu_{\text{e}^-}}}{N_{\text{Ar}^+}^{\nu_{\text{Ar}^+}}} \left(\frac{P}{N_{\text{total}}} \right)^{(\nu_{\text{Ar}^+} + \nu_{\text{e}^-} - \nu_{\text{Ar}})} = \frac{y^2}{x} \left(\frac{P}{N_{\text{total}}} \right)^{1+1-1}$$

Substituting,

$$0.00042 = \frac{(1-x)^2}{x} \left(\frac{0.35}{2-x} \right)$$

Solving for x ,

$$x = 0.965$$

Thus the fraction of Ar which dissociates into Ar^+ and e^- is

$$1 - 0.965 = 0.035 \quad \text{or} \quad \mathbf{3.5\%}$$

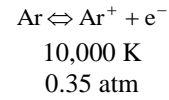

16-84 The equilibrium constant of the dissociation process $O_2 \leftrightarrow 2O$ is given in Table A-28 at different temperatures. The value at a given temperature is to be verified using Gibbs function data.

Analysis The K_p value of a reaction at a specified temperature can be determined from the Gibbs function data using

$$K_p = e^{-\Delta G^*(T)/R_u T} \quad \text{or} \quad \ln K_p = -\Delta G^*(T) / R_u T$$

where

$$\begin{aligned} \Delta G^*(T) &= \nu_O \bar{g}_O^*(T) - \nu_{O_2} \bar{g}_{O_2}^*(T) \\ &= \nu_O (\bar{h} - T\bar{s})_O - \nu_{O_2} (\bar{h} - T\bar{s})_{O_2} \\ &= \nu_O [(\bar{h}_f + \bar{h}_{2000} - \bar{h}_{298}) - T\bar{s}]_O - \nu_{O_2} [(\bar{h}_f + \bar{h}_{2000} - \bar{h}_{298}) - T\bar{s}]_{O_2} \\ &= 2 \times (249,190 + 42,564 - 6852 - 2000 \times 201.135) \\ &\quad - 1 \times (0 + 67,881 - 8682 - 2000 \times 268.655) \\ &= 243,375 \text{ kJ/kmol} \end{aligned}$$

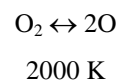

Substituting,

$$\ln K_p = -(243,375 \text{ kJ/kmol}) / [(8.314 \text{ kJ/kmol} \cdot \text{K})(2000 \text{ K})] = -14.636$$

or

$$K_p = 4.4 \times 10^{-7} \quad (\text{Table A-28: } \ln K_p = -14.622)$$

16-85 The equilibrium constant for the reaction $CH_4 + 2O_2 \leftrightarrow CO_2 + 2H_2O$ at 100 kPa and 2000 K is to be determined.

Assumptions 1 The constituents of the mixture are ideal gases.

Analysis This is a simultaneous reaction. We can begin with the dissociation of methane and carbon dioxide,



When these two reactions are summed and the common carbon term cancelled, the result is



Next, we include the water dissociation reaction (Table A-28),



which when summed with the previous reaction and the common hydrogen term is cancelled yields



Then,

$$\ln K_p = \mathbf{32.282}$$

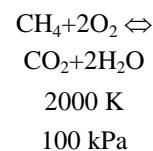

16-86 A glass of water is left in a room. The mole fraction of the water vapor in the air at the water surface and far from the surface as well as the mole fraction of air in the water near the surface are to be determined when the water and the air are at the same temperature.

Assumptions 1 Both the air and water vapor are ideal gases. **2** Air is weakly soluble in water and thus Henry's law is applicable.

Properties The saturation pressure of water at 25°C is 3.170 kPa (Table A-4). Henry's constant for air dissolved in water at 25°C (298 K) is given in Table 16-2 to be $H = 71,600$ bar. Molar masses of dry air and water are 29 and 18 kg/kmol, respectively (Table A-1).

Analysis (a) Noting that the relative humidity of air is 70%, the partial pressure of water vapor in the air far from the water surface will be

$$P_{v, \text{room air}} = \phi P_{\text{sat @ } 25^\circ\text{C}} = (0.7)(3.170 \text{ kPa}) = 2.219 \text{ kPa}$$

Assuming both the air and vapor to be ideal gases, the mole fraction of water vapor in the room air is

$$y_{\text{vapor}} = \frac{P_{\text{vapor}}}{P} = \frac{2.219 \text{ kPa}}{100 \text{ kPa}} = \mathbf{0.0222} \quad (\text{or } \mathbf{2.22\%})$$

(b) Noting that air at the water surface is saturated, the partial pressure of water vapor in the air near the surface will simply be the saturation pressure of water at 25°C, $P_{v, \text{interface}} = P_{\text{sat @ } 25^\circ\text{C}} = 3.170 \text{ kPa}$. Then the mole fraction of water vapor in the air at the interface becomes

$$y_{v, \text{surface}} = \frac{P_{v, \text{surface}}}{P} = \frac{3.170 \text{ kPa}}{100 \text{ kPa}} = \mathbf{0.0317} \quad (\text{or } \mathbf{3.17\%})$$

(c) Noting that the total pressure is 100 kPa, the partial pressure of dry air at the water surface is

$$P_{\text{air, surface}} = P - P_{v, \text{surface}} = 100 - 3.170 = 96.83 \text{ kPa}$$

From Henry's law, the mole fraction of air in the water is determined to be

$$y_{\text{dry air, liquid side}} = \frac{P_{\text{dry air, gas side}}}{H} = \frac{(96.83/100) \text{ bar}}{71,600 \text{ bar}} = \mathbf{1.35 \times 10^{-5}}$$

Discussion The water cannot remain at the room temperature when the air is not saturated. Therefore, some water will evaporate and the water temperature will drop until a balance is reached between the rate of heat transfer to the water and the rate of evaporation.

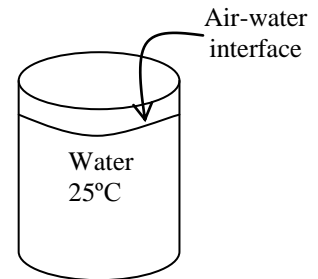

16-87 A glass of water is left in a room. The mole fraction of the water vapor in the air at the water surface and far from the surface as well as the mole fraction of air in the water near the surface are to be determined when the water and the air are at the same temperature.

Assumptions 1 Both the air and water vapor are ideal gases. **2** Air is weakly soluble in water and thus Henry's law is applicable.

Properties The saturation pressure of water at 25°C is 3.170 kPa (Table A-4). Henry's constant for air dissolved in water at 25°C (298 K) is given in Table 16-2 to be $H = 71,600$ bar. Molar masses of dry air and water are 29 and 18 kg/kmol, respectively (Table A-1).

Analysis (a) Noting that the relative humidity of air is 40%, the partial pressure of water vapor in the air far from the water surface will be

$$P_{v, \text{room air}} = \phi P_{\text{sat @ } 25^\circ\text{C}} = (0.25)(3.170 \text{ kPa}) = 0.7925 \text{ kPa}$$

Assuming both the air and vapor to be ideal gases, the mole fraction of water vapor in the room air is

$$y_{\text{vapor}} = \frac{P_{\text{vapor}}}{P} = \frac{0.7925 \text{ kPa}}{100 \text{ kPa}} = \mathbf{0.0079} \quad (\text{or } \mathbf{0.79\%})$$

(b) Noting that air at the water surface is saturated, the partial pressure of water vapor in the air near the surface will simply be the saturation pressure of water at 25°C, $P_{v, \text{interface}} = P_{\text{sat @ } 25^\circ\text{C}} = 3.170 \text{ kPa}$. Then the mole fraction of water vapor in the air at the interface becomes

$$y_{v, \text{surface}} = \frac{P_{v, \text{surface}}}{P} = \frac{3.170 \text{ kPa}}{100 \text{ kPa}} = \mathbf{0.0317} \quad (\text{or } \mathbf{3.17\%})$$

(c) Noting that the total pressure is 100 kPa, the partial pressure of dry air at the water surface is

$$P_{\text{air, surface}} = P - P_{v, \text{surface}} = 100 - 3.170 = 96.83 \text{ kPa}$$

From Henry's law, the mole fraction of air in the water is determined to be

$$y_{\text{dry air, liquid side}} = \frac{P_{\text{dry air, gas side}}}{H} = \frac{(96.83/100) \text{ bar}}{71,600 \text{ bar}} = \mathbf{1.35 \times 10^{-5}}$$

Discussion The water cannot remain at the room temperature when the air is not saturated. Therefore, some water will evaporate and the water temperature will drop until a balance is reached between the rate of heat transfer to the water and the rate of evaporation.



16-88 Methane gas is burned with stoichiometric amount of air during a combustion process. The equilibrium composition and the exit temperature are to be determined.

Assumptions 1 The product gases consist of CO_2 , H_2O , CO , N_2 , and O_2 . **2** The constituents of the mixture are ideal gases. **3** This is an adiabatic and steady-flow combustion process.

Analysis (a) The combustion equation of CH_4 with stoichiometric amount of O_2 can be written as

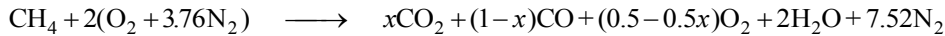

After combustion, there will be no CH_4 present in the combustion chamber, and H_2O will act like an inert gas. The equilibrium equation among CO_2 , CO , and O_2 can be expressed as

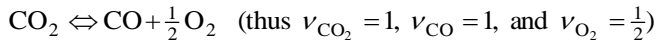

and
$$K_p = \frac{N_{\text{CO}}^{\nu_{\text{CO}}} N_{\text{O}_2}^{\nu_{\text{O}_2}}}{N_{\text{CO}_2}^{\nu_{\text{CO}_2}}} \left(\frac{P}{N_{\text{total}}} \right)^{(\nu_{\text{CO}} + \nu_{\text{O}_2} - \nu_{\text{CO}_2})}$$

where $N_{\text{total}} = x + (1-x) + (1.5 - 0.5x) + 2 + 7.52 = 12.02 - 0.5x$

Substituting,

$$K_p = \frac{(1-x)(0.5 - 0.5x)^{0.5}}{x} \left(\frac{1}{12.02 - 0.5x} \right)^{1.5-1}$$

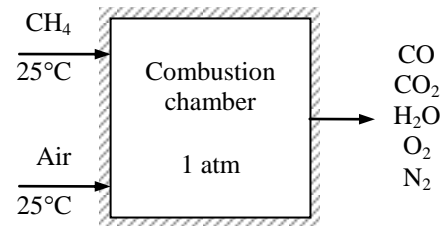

The value of K_p depends on temperature of the products, which is yet to be determined. A second relation to determine K_p and x is obtained from the steady-flow energy balance expressed as

$$0 = \sum N_P (\bar{h}_f^\circ + \bar{h} - \bar{h}^\circ)_P - \sum N_R (\bar{h}_f^\circ + \bar{h} - \bar{h}^\circ)_R \longrightarrow 0 = \sum N_P (\bar{h}_f^\circ + \bar{h} - \bar{h}^\circ)_P - \sum N_R \bar{h}_f^\circ$$

since the combustion is adiabatic and the reactants enter the combustion chamber at 25°C . Assuming the air and the combustion products to be ideal gases, we have $h = h(T)$. From the tables,

Substance	\bar{h}_f° , kJ/kmol	$\bar{h}_{298\text{K}}$, kJ/kmol
$\text{CH}_4(\text{g})$	-74,850	--
N_2	0	8669
O_2	0	8682
$\text{H}_2\text{O}(\text{g})$	-241,820	9904
CO	-110,530	8669
CO_2	-393,520	9364

Substituting,

$$\begin{aligned} 0 = & x(-393,520 + \bar{h}_{\text{CO}_2} - 9364) + (1-x)(-110,530 + \bar{h}_{\text{CO}} - 8669) \\ & + 2(-241,820 + \bar{h}_{\text{H}_2\text{O}} - 9904) + (0.5 - 0.5x)(0 + \bar{h}_{\text{O}_2} - 8682) \\ & + 7.52(0 + \bar{h}_{\text{N}_2} - 8669) - 1(-74,850 + h_{298} - h_{298}) - 0 - 0 \end{aligned}$$

which yields

$$x\bar{h}_{\text{CO}_2} + (1-x)\bar{h}_{\text{CO}} + 2\bar{h}_{\text{H}_2\text{O}} + (0.5 - 0.5x)\bar{h}_{\text{O}_2} + 7.52\bar{h}_{\text{N}_2} - 279,344x = 617,329$$

Now we have two equations with two unknowns, T_p and x . The solution is obtained by trial and error by assuming a temperature T_p , calculating the equilibrium composition from the first equation, and then checking to see if the second equation is satisfied. A first guess is obtained by assuming there is no CO in the products, i.e., $x = 1$. It yields $T_p = 2328\text{ K}$. The adiabatic combustion temperature with incomplete combustion will be less.

$$\text{Take } T_p = 2300\text{ K} \longrightarrow \ln K_p = -4.49 \longrightarrow x = 0.870 \longrightarrow \text{RHS} = 641,093$$

$$\text{Take } T_p = 2250\text{ K} \longrightarrow \ln K_p = -4.805 \longrightarrow x = 0.893 \longrightarrow \text{RHS} = 612,755$$

By interpolation, $T_p = 2258\text{ K}$ and $x = 0.889$

Thus the composition of the equilibrium mixture is

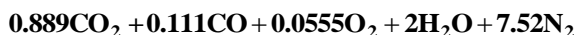



16-89 Problem 16-88 is reconsidered. The effect of excess air on the equilibrium composition and the exit temperature by varying the percent excess air from 0 to 200 percent is to be studied.

Analysis The problem is solved using EES, and the solution is given below.

"Often, for nonlinear problems such as this one, good guesses are required to start the solution. First, run the program with zero percent excess air to determine the net heat transfer as a function of T_{prod} . Just press F3 or click on the Solve Table icon. From Plot Window 1, where Q_{net} is plotted vs T_{prod} , determine the value of T_{prod} for $Q_{\text{net}}=0$ by holding down the Shift key and move the cross hairs by moving the mouse. Q_{net} is approximately zero at $T_{\text{prod}} = 2269$ K. From Plot Window 2 at $T_{\text{prod}} = 2269$ K, a, b, and c are approximately 0.89, 0.10, and 0.056, respectively." "For EES to calculate a, b, c, and T_{prod} directly for the adiabatic case, remove the '{ }' in the last line of this window to set $Q_{\text{net}} = 0.0$. Then from the Options menu select Variable Info and set the Guess Values of a, b, c, and T_{prod} to the guess values selected from the Plot Windows. Then press F2 or click on the Calculator icon."

"Input Data"

{PercentEx = 0}

Ex = PercentEX/100

P_{prod} = 101.3 [kPa]

R_u = 8.314 [kJ/kmol-K]

T_{fuel} = 298 [K]

T_{air} = 298 [K]

"The combustion equation of CH₄ with stoichiometric amount of air is

CH₄ + (1+Ex)(2)(O₂ + 3.76N₂) = CO₂ + 2H₂O + (1+Ex)(2)(3.76)N₂"

"For the incomplete combustion process in this problem, the combustion equation is

CH₄ + (1+Ex)(2)(O₂ + 3.76N₂) = aCO₂ + bCO + cO₂ + 2H₂O + (1+Ex)(2)(3.76)N₂"

"Specie balance equations"

"O"

4 = a * 2 + b + c * 2 + 2

"C"

1 = a + b

N_{tot} = a + b + c + 2 + (1+Ex)(2)*3.76 "Total kilomoles of products at equilibrium"

"We assume the equilibrium reaction is

CO₂ = CO + 0.5O₂"

"The following equations provide the specific Gibbs function ($g = h - Ts$) for each component as a function of its temperature at 1 atm pressure, 101.3 kPa"

$g_{\text{CO}_2} = \text{Enthalpy}(\text{CO}_2, T = T_{\text{prod}}) - T_{\text{prod}} * \text{Entropy}(\text{CO}_2, T = T_{\text{prod}}, P = 101.3)$

$g_{\text{CO}} = \text{Enthalpy}(\text{CO}, T = T_{\text{prod}}) - T_{\text{prod}} * \text{Entropy}(\text{CO}, T = T_{\text{prod}}, P = 101.3)$

$g_{\text{O}_2} = \text{Enthalpy}(\text{O}_2, T = T_{\text{prod}}) - T_{\text{prod}} * \text{Entropy}(\text{O}_2, T = T_{\text{prod}}, P = 101.3)$

"The standard-state Gibbs function is"

$\Delta G = 1 * g_{\text{CO}} + 0.5 * g_{\text{O}_2} - 1 * g_{\text{CO}_2}$

"The equilibrium constant is given by Eq. 16-14."

$K_P = \exp(-\Delta G / (R_u * T_{\text{prod}}))$

$P = P_{\text{prod}} / 101.3 \text{ "atm"}$

"The equilibrium constant is also given by Eq. 16-15."

$K_P = (P/N_{\text{tot}})^{(1+0.5-1)} * (b^1 * c^{0.5}) / (a^1)$

$\sqrt{P/N_{\text{tot}}} * b * \sqrt{c} = K_P * a$

"Conservation of energy for the reaction, assuming SSSF, neglecting work, ke , and pe :"

$E_{\text{in}} - E_{\text{out}} = \Delta E_{\text{cv}}$

$E_{\text{in}} = Q_{\text{net}} + HR$

"The enthalpy of the reactant gases is"

$HR = \text{enthalpy}(\text{CH}_4, T = T_{\text{fuel}}) + (1+Ex)(2) * \text{enthalpy}(\text{O}_2, T = T_{\text{air}}) + (1+Ex)(2) * 3.76 * \text{enthalpy}(\text{N}_2, T = T_{\text{air}})$

$E_{\text{out}} = HP$

"The enthalpy of the product gases is"

$HP = a * \text{enthalpy}(\text{CO}_2, T = T_{\text{prod}}) + b * \text{enthalpy}(\text{CO}, T = T_{\text{prod}}) + 2 * \text{enthalpy}(\text{H}_2\text{O}, T = T_{\text{prod}}) + (1+Ex)(2) * 3.76 * \text{enthalpy}(\text{N}_2, T = T_{\text{prod}}) + c * \text{enthalpy}(\text{O}_2, T = T_{\text{prod}})$

$\Delta E_{\text{cv}} = 0$ "Steady-flow requirement"

$Q_{\text{net}} = 0$ "For an adiabatic reaction the net heat added is zero."

PercentEx	T _{prod} [K]
0	2260
20	2091
40	1940
60	1809
80	1695
100	1597
120	1511
140	1437
160	1370
180	1312
200	1259

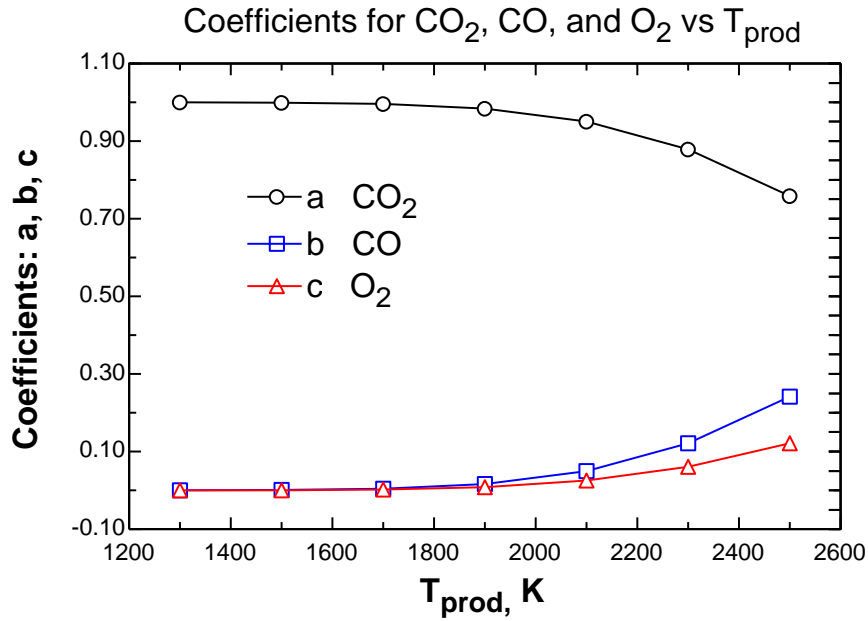
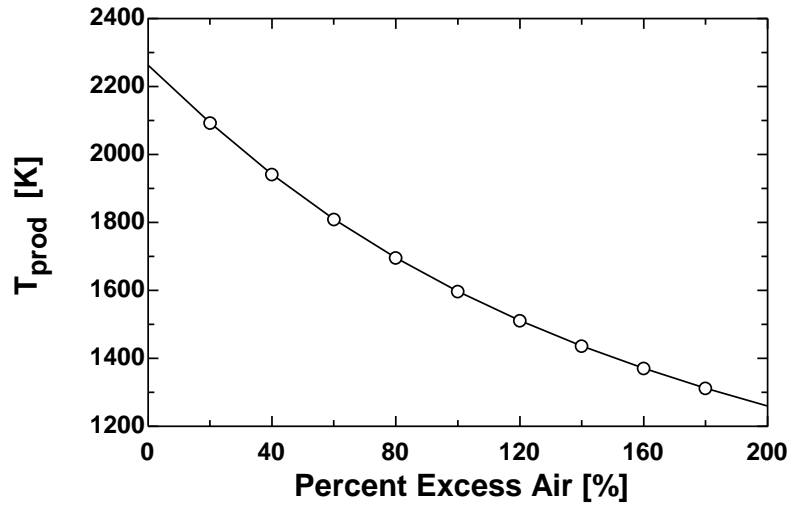

16-90 The equilibrium partial pressure of the carbon dioxide for the reaction $\text{CH}_4 + 2\text{O}_2 \leftrightarrow \text{CO}_2 + 2\text{H}_2\text{O}$ at 450 kPa and 3000 K is to be determined.

Assumptions 1 The equilibrium composition consists of CH_4 , O_2 , CO_2 , and H_2O . **2** The constituents of the mixture are ideal gases.

Analysis This is a simultaneous reaction. We can begin with the dissociation of methane and carbon dioxide,

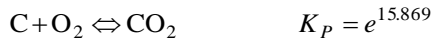

When these two reactions are summed and the common carbon term cancelled, the result is



Next, we include the water dissociation reaction,

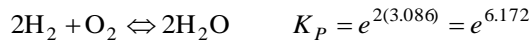

which when summed with the previous reaction and the common hydrogen term is cancelled yields



Then,

$$\ln K_p = 12.356$$

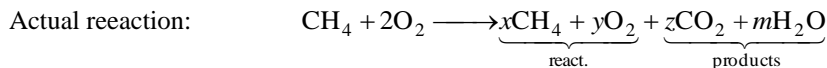

C balance: $1 = x + z \longrightarrow z = 1 - x$

H balance: $4 = 4x + 2m \longrightarrow m = 2 - 2x$

O balance: $4 = 2y + 2z + m \longrightarrow y = 2x$

Total number of moles: $N_{\text{total}} = x + y + z + m = 3$

The equilibrium constant relation can be expressed as

$$K_p = \frac{N_{\text{CO}_2}^{v_{\text{CO}_2}} N_{\text{H}_2\text{O}}^{v_{\text{H}_2\text{O}}}}{N_{\text{CH}_4}^{v_{\text{CH}_4}} N_{\text{O}_2}^{v_{\text{O}_2}}} \left(\frac{P}{N_{\text{total}}} \right)^{v_{\text{CO}_2} + v_{\text{H}_2\text{O}} - v_{\text{CH}_4} - v_{\text{O}_2}}$$

Substituting,

$$e^{12.356} = \frac{(1-x)(2-2x)^2}{x(2x)^2} \left(\frac{450/101.325}{3} \right)^{1+2-1-2}$$

Solving for x ,

$$x = 0.01601$$

Then,

$$y = 2x = 0.03201$$

$$z = 1 - x = 0.98399$$

$$m = 2 - 2x = 1.96799$$

Therefore, the equilibrium composition of the mixture at 3000 K and 450 kPa is

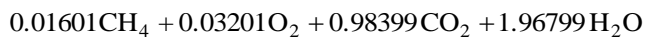

The mole fraction of carbon dioxide is

$$y_{\text{CO}_2} = \frac{0.98399}{3} = 0.3280$$

and the partial pressure of the carbon dioxide in the product mixture is

$$P_{\text{CO}_2} = y_{\text{CO}_2}P = (0.3280)(450 \text{ kPa}) = \mathbf{148 \text{ kPa}}$$

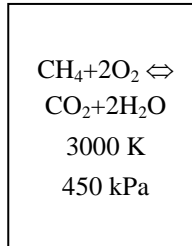

16-91 Methane is heated from a specified state to another state. The amount of heat required is to be determined without and with dissociation cases.

Properties The molar mass and gas constant of methane are 16.043 kg/kmol and 0.5182 kJ/kg·K (Table A-1).

Assumptions 1 The equilibrium composition consists of O₂ and O. **2** The constituents of the mixture are ideal gases.

Analysis (a) An energy balance for the process gives

$$\underbrace{E_{\text{in}} - E_{\text{out}}}_{\substack{\text{Net energy transfer} \\ \text{by heat, work, and mass}}} = \underbrace{\Delta E_{\text{system}}}_{\substack{\text{Change in internal, kinetic,} \\ \text{potential, etc. energies}}}$$

$$Q_{\text{in}} = N(\bar{u}_2 - \bar{u}_1)$$

$$= N[\bar{h}_2 - \bar{h}_1 - R_u(T_2 - T_1)]$$

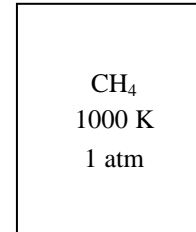

Using the empirical coefficients of Table A-2c,

$$\bar{h}_2 - \bar{h}_1 = \int_1^2 c_p dT = a(T_2 - T_1) + \frac{b}{2}(T_2^2 - T_1^2) + \frac{c}{3}(T_2^3 - T_1^3) + \frac{d}{4}(T_2^4 - T_1^4)$$

$$= 19.89(1000 - 298) + \frac{0.05024}{2}(1000^2 - 298^2) + \frac{1.269 \times 10^{-5}}{3}(1000^3 - 298^3)$$

$$+ \frac{-11.01 \times 10^{-9}}{4}(1000^4 - 298^4)$$

$$= 38,239 \text{ kJ/kmol}$$

Substituting,

$$Q_{\text{in}} = (10 \text{ kmol})[38,239 \text{ kJ/kmol} - (8.314 \text{ kJ/kmol} \cdot \text{K})(1000 - 298)\text{K}] = \mathbf{324,000 \text{ kJ}}$$

(b) The stoichiometric and actual reactions in this case are

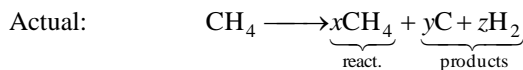
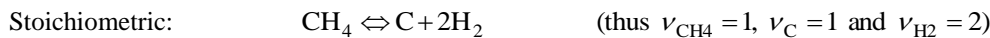

C balance: $1 = x + y \longrightarrow y = 1 - x$

H balance: $4 = 4x + 2z \longrightarrow z = 2 - 2x$

Total number of moles: $N_{\text{total}} = x + y + z = 3 - 2x$

The equilibrium constant relation can be expressed as

$$K_p = \frac{N_{\text{C}}^{\nu_{\text{C}}} N_{\text{H}_2}^{\nu_{\text{H}_2}}}{N_{\text{CH}_4}^{\nu_{\text{CH}_4}}} \left(\frac{P}{N_{\text{total}}} \right)^{\nu_{\text{C}} + \nu_{\text{H}_2} - \nu_{\text{CH}_4}}$$

From the problem statement, at 1000 K, $\ln K_p = -2.328$. Then,

$$K_p = e^{-2.328} = 0.09749$$

Substituting,

$$0.09749 = \frac{(1-x)(2-2x)^2}{x} \left(\frac{1}{3-2x} \right)^{1+2-1}$$

Solving for x ,

$$x = 0.6414$$

Then,

$$y = 1 - x = 0.3586$$

$$z = 2 - 2x = 0.7172$$

Therefore, the equilibrium composition of the mixture at 1000 K and 1 atm is

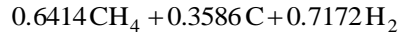

The mole fractions are

$$y_{\text{CH}_4} = \frac{N_{\text{CH}_4}}{N_{\text{total}}} = \frac{0.6414}{0.6414 + 0.3586 + 0.7172} = \frac{0.6414}{1.7172} = 0.3735$$

$$y_{\text{C}} = \frac{N_{\text{C}}}{N_{\text{total}}} = \frac{0.3586}{1.7172} = 0.2088$$

$$y_{\text{H}_2} = \frac{N_{\text{H}_2}}{N_{\text{total}}} = \frac{0.7172}{1.7172} = 0.4177$$

The heat transfer can be determined from

$$\begin{aligned} Q_{\text{in}} &= N(y_{\text{CH}_4}c_{\nu,\text{CH}_4}T_2 + y_{\text{H}_2}c_{\nu,\text{H}_2}T_2 + y_{\text{C}}c_{\nu,\text{C}}T_2) - Nc_{\nu,\text{CH}_4}T_1 \\ &= (10)[(0.3735)(63.3)(1000) + (0.4177)(21.7)(1000) + (0.2088)(0.711)(1000)] - (10)(27.8)(298) \\ &= \mathbf{245,700\text{kJ}} \end{aligned}$$

16-92 Solid carbon is burned with a stoichiometric amount of air. The number of moles of CO_2 formed per mole of carbon is to be determined.

Assumptions 1 The equilibrium composition consists of CO_2 , CO , O_2 , and N_2 . **2** The constituents of the mixture are ideal gases.

Analysis Inspection of Table A-28 reveals that the dissociation equilibrium constants of CO_2 , O_2 , and N_2 are quite small and therefore may be neglected. (We learned from another source that the equilibrium constant for CO is also small). The combustion is then complete and the reaction is described by

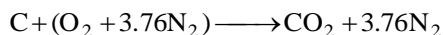

The number of moles of CO_2 in the products is then

$$\frac{N_{\text{CO}_2}}{N_{\text{C}}} = 1$$

Carbon + Air
25°C

16-93 Solid carbon is burned with a stoichiometric amount of air. The amount of heat released per kilogram of carbon is to be determined.

Assumptions 1 The equilibrium composition consists of CO_2 , CO , O_2 , and N_2 . **2** The constituents of the mixture are ideal gases.

Analysis Inspection of Table A-28 reveals that the dissociation equilibrium constants of CO_2 , O_2 , and N_2 are quite small and therefore may be neglected. (We learned from another source that the equilibrium constant for CO is also small). The combustion is then complete and the reaction is described by

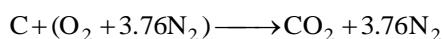

The heat transfer for this combustion process is determined from the energy balance $E_{\text{in}} - E_{\text{out}} = \Delta E_{\text{system}}$ applied on the combustion chamber with $W = 0$. It reduces to

$$-Q_{\text{out}} = \sum N_P (\bar{h}_f^\circ + \bar{h} - \bar{h}^\circ)_P - \sum N_R (\bar{h}_f^\circ + \bar{h} - \bar{h}^\circ)_R$$

Assuming the air and the combustion products to be ideal gases, we have $h = h(T)$. From the tables,

Substance	\bar{h}_f° kJ/kmol	$\bar{h}_{298\text{K}}$ kJ/kmol	$\bar{h}_{1000\text{K}}$ kJ/kmol
N_2	0	8669	30,129
CO_2	-393,520	9364	42,769

Substituting,

$$\begin{aligned} -Q_{\text{out}} &= (1)(-393,520 + 42,769 - 9364) + (3.76)(0 + 30,129 - 8669) \\ &= -279,425 \text{ kJ/kmol C} \end{aligned}$$

or
$$Q_{\text{out}} = \frac{279,425 \text{ kJ/kmol}}{12 \text{ kg/kmol}} = \mathbf{23,285 \text{ kJ/kg carbon}}$$

Carbon + Air
25°C

16-94 Methane gas is burned with 30 percent excess air. The equilibrium composition of the products of combustion and the amount of heat released by this combustion are to be determined.

Assumptions 1 The equilibrium composition consists of CO_2 , H_2O , O_2 , NO , and N_2 . **2** The constituents of the mixture are ideal gases.

Analysis Inspection of the equilibrium constants of the possible reactions indicate that only the formation of NO need to be considered in addition to other complete combustion products. Then, the stoichiometric and actual reactions in this case are

Stoichiometric: $\text{N}_2 + \text{O}_2 \Leftrightarrow 2\text{NO}$ (thus $\nu_{\text{N}_2} = 1$, $\nu_{\text{O}_2} = 1$, and $\nu_{\text{NO}} = 2$)

Actual: $\text{CH}_4 + 2.6(\text{O}_2 + 3.76\text{N}_2) \longrightarrow \text{CO}_2 + 2\text{H}_2\text{O} + x\text{NO} + y\text{O}_2 + z\text{N}_2$

N balance: $2 \times 9.776 = x + 2z \longrightarrow z = 9.776 - 0.5x$

O balance: $5.2 = 2 + 2 + x + 2y \longrightarrow y = 0.6 - 0.5x$

Total number of moles: $N_{\text{total}} = 1 + 2 + x + y + z = 13.38$

The equilibrium constant relation can be expressed as

$$K_p = \frac{N_{\text{NO}}^{\nu_{\text{NO}}}}{N_{\text{N}_2}^{\nu_{\text{N}_2}} N_{\text{O}_2}^{\nu_{\text{O}_2}}} \left(\frac{P}{N_{\text{total}}} \right)^{(\nu_{\text{NO}} - \nu_{\text{N}_2} - \nu_{\text{O}_2})}$$

From Table A-28, at 1600 K, $\ln K_p = -5.294$. Since the stoichiometric reaction being considered is double this reaction,

$$K_p = \exp(-2 \times 5.294) = 2.522 \times 10^{-5}$$

Substituting,

$$2.522 \times 10^{-5} = \frac{x^2}{(0.6 - 0.5x)(9.776 - 0.5x)} \left(\frac{1}{13.38} \right)^{2-1-1}$$

Solving for x ,

$$x = 0.0121$$

Then,

$$y = 0.6 - 0.5x = 0.594$$

$$z = 9.776 - 0.5x = 9.77$$

Therefore, the equilibrium composition of the products mixture at 1600 K and 1 atm is

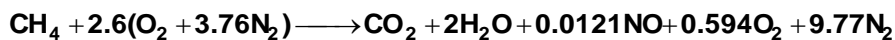

The heat transfer for this combustion process is determined from the energy balance $E_{\text{in}} - E_{\text{out}} = \Delta E_{\text{system}}$ applied on the combustion chamber with $W = 0$. It reduces to

$$-Q_{\text{out}} = \sum N_P (\bar{h}_f^\circ + \bar{h} - \bar{h}^\circ)_P - \sum N_R (\bar{h}_f^\circ + \bar{h} - \bar{h}^\circ)_R$$

Assuming the air and the combustion products to be ideal gases, we have $h = h(T)$. From the tables,

Substance	\bar{h}_f° kJ/kmol	$\bar{h}_{298\text{K}}$ kJ/kmol	$\bar{h}_{1600\text{K}}$ kJ/kmol
CH_4	-74,850	---	---
O_2	0	8682	52,961
N_2	0	8669	50,571
H_2O	-241,820	9904	62,748
CO_2	-393,520	9364	76,944

Neglecting the effect of NO in the energy balance and substituting,

$$\begin{aligned} -Q_{\text{out}} &= (1)(-393,520 + 76,944 - 9364) + (2)(-241,820 + 62,748 - 9904) + 0.594(52,961 - 8682) \\ &\quad + (9.77)(50,571 - 8669) - (-74,850) \\ &= -193,500 \text{ kJ/kmol CH}_4 \end{aligned}$$

or $Q_{\text{out}} = 193,500 \text{ kJ/kmol CH}_4$

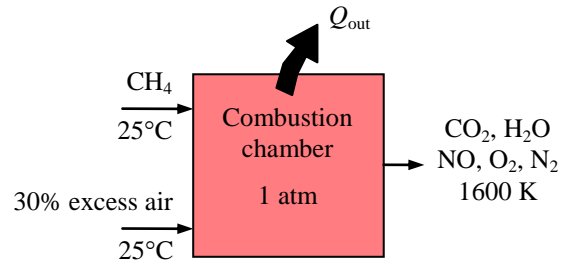

16-95E Gaseous octane gas is burned with 40% excess air. The equilibrium composition of the products of combustion is to be determined.

Assumptions 1 The equilibrium composition consists of CO_2 , H_2O , O_2 , NO , and N_2 . **2** The constituents of the mixture are ideal gases.

Analysis The stoichiometric and actual reactions in this case are

Stoichiometric: $\text{N}_2 + \text{O}_2 \leftrightarrow 2\text{NO}$ (thus $\nu_{\text{N}_2} = 1$, $\nu_{\text{O}_2} = 1$, and $\nu_{\text{NO}} = 2$)

Actual: $\text{C}_8\text{H}_{18} + 1.4 \times 12.5(\text{O}_2 + 3.76\text{N}_2) \longrightarrow 8\text{CO}_2 + 9\text{H}_2\text{O} + x\text{NO} + y\text{O}_2 + z\text{N}_2$

N balance: $131.6 = x + 2z \longrightarrow z = 65.8 - 0.5x$

O balance: $35 = 16 + 9 + x + 2y \longrightarrow y = 5 - 0.5x$

Total number of moles: $N_{\text{total}} = 8 + 9 + x + y + z = 87.8$

The equilibrium constant relation can be expressed as

$$K_p = \frac{N_{\text{NO}}^{\nu_{\text{NO}}}}{N_{\text{N}_2}^{\nu_{\text{N}_2}} N_{\text{O}_2}^{\nu_{\text{O}_2}}} \left(\frac{P}{N_{\text{total}}} \right)^{(\nu_{\text{NO}} - \nu_{\text{N}_2} - \nu_{\text{O}_2})}$$

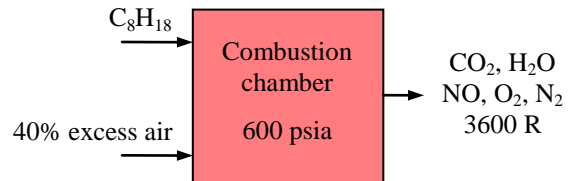

From Table A-28, at 2000 K (3600 R), $\ln K_p = -3.931$. Since the stoichiometric reaction being considered is double this reaction,

$$K_p = \exp(-2 \times 3.931) = 3.851 \times 10^{-4}$$

Substituting,

$$3.851 \times 10^{-4} = \frac{x^2}{(5 - 0.5x)(65.8 - 0.5x)} \left(\frac{600/14.7}{87.8} \right)^{2-1-1}$$

Solving for x ,

$$x = 0.3492$$

Then,

$$y = 5 - 0.5x = 4.825$$

$$z = 65.8 - 0.5x = 65.63$$

Therefore, the equilibrium composition of the products mixture at 2000 K and 4 MPa is

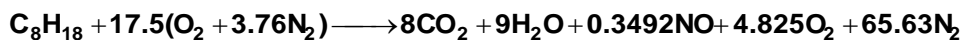

16-96 Propane gas is burned with stoichiometric air in an adiabatic manner. The temperature of the products and the equilibrium composition of the products are to be determined.

Assumptions 1 The equilibrium composition consists of CO_2 , H_2O , O_2 , NO , and N_2 . **2** The constituents of the mixture are ideal gases.

Analysis (a) The stoichiometric and actual reactions in this case are

Stoichiometric: $\text{N}_2 + \text{O}_2 \leftrightarrow 2\text{NO}$ (thus $\nu_{\text{N}_2} = 1$, $\nu_{\text{O}_2} = 1$, and $\nu_{\text{NO}} = 2$)

Actual: $\text{C}_3\text{H}_8 + 1.1 \times 5(\text{O}_2 + 3.76\text{N}_2) \longrightarrow 3\text{CO}_2 + 4\text{H}_2\text{O} + x\text{NO} + y\text{O}_2 + z\text{N}_2$

N balance: $41.36 = x + 2z \longrightarrow z = 20.68 - 0.5x$

O balance: $11 = 6 + 4 + x + 2y \longrightarrow y = 0.5 - 0.5x$

Total number of moles: $N_{\text{total}} = 3 + 4 + x + y + z = 21.18$

The equilibrium constant relation can be expressed as

$$K_p = \frac{N_{\text{NO}}^{\nu_{\text{NO}}}}{N_{\text{N}_2}^{\nu_{\text{N}_2}} N_{\text{O}_2}^{\nu_{\text{O}_2}}} \left(\frac{P}{N_{\text{total}}} \right)^{(\nu_{\text{NO}} - \nu_{\text{N}_2} - \nu_{\text{O}_2})}$$

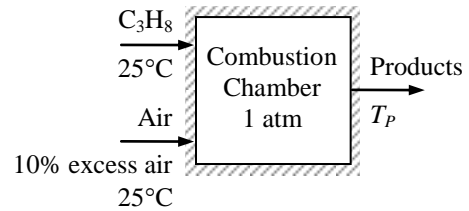

We assume that the products will be at 2000 K. Then from Table A-28, at 2000 K, $\ln K_p = -3.931$. Since the stoichiometric reaction being considered is double this reaction,

$$K_p = \exp(-2 \times 3.931) = 3.851 \times 10^{-4}$$

Substituting,

$$3.851 \times 10^{-4} = \frac{x^2}{(0.5 - 0.5x)(20.68 - 0.5x)} \left(\frac{1}{21.18} \right)^{2-1-1}$$

Solving for x ,

$$x = 0.0611$$

Then,

$$y = 0.5 - 0.5x = 0.4695$$

$$z = 20.68 - 0.5x = 20.65$$

Therefore, the equilibrium composition of the products mixture at 2000 K and 1 atm is

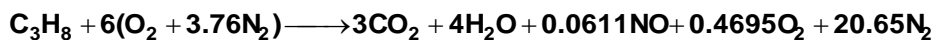

(b) From the tables,

Substance	\bar{h}_f° , kJ/kmol	$\bar{h}_{298\text{K}}$, kJ/kmol
C_3H_8 (g)	-103,850	---
O_2	0	8682
N_2	0	8669
H_2O (g)	-241,820	9904
CO_2	-393,520	9364

Thus,

$$(3)(-393,520 + \bar{h}_{\text{CO}_2} - 9364) + (4)(-241,820 + \bar{h}_{\text{H}_2\text{O}} - 9904) + (0.0611)(39,460 + \bar{h}_{\text{OH}} - 9188) \\ + (0.4695)(0 + \bar{h}_{\text{O}_2} - 8682) + (20.65)(0 + \bar{h}_{\text{N}_2} - 8669) = (1)(-103,850) + 0 + 0$$

It yields

$$3\bar{h}_{\text{CO}_2} + 4\bar{h}_{\text{H}_2\text{O}} + 0.0611\bar{h}_{\text{OH}} + 0.4695\bar{h}_{\text{O}_2} + 20.65\bar{h}_{\text{N}_2} = 2,292,940 \text{ kJ}$$

The adiabatic flame temperature is obtained from a trial and error solution. A first guess is obtained by dividing the right-hand side of the equation by the total number of moles, which yields $2,292,940/(3+4+0.0611+0.4695+20.65) = 81,366$ kJ/kmol. This enthalpy value corresponds to about 2450 K for N_2 . Noting that the majority of the moles are N_2 , T_p will be close to 2450 K, but somewhat under it because of the higher specific heat of H_2O .

At 2200 K:

$$\begin{aligned} 3\bar{h}_{\text{CO}_2} + 4\bar{h}_{\text{H}_2\text{O}} + 0.0611\bar{h}_{\text{OH}} + 0.4695\bar{h}_{\text{O}_2} + 20.65\bar{h}_{\text{N}_2} &= 3(112,939) + 4(92,940) + 0.0611(69,932) \\ &+ 0.4695(75,484) + 20.65(64,810) = 2,088,620 \text{ kJ (Lower than 2,292,940)} \end{aligned}$$

At 2400 K:

$$\begin{aligned} 3\bar{h}_{\text{CO}_2} + 4\bar{h}_{\text{H}_2\text{O}} + 0.0611\bar{h}_{\text{OH}} + 0.4695\bar{h}_{\text{O}_2} + 20.65\bar{h}_{\text{N}_2} &= 3(125,152) + 4(103,508) + 0.0611(77,015) \\ &+ 0.4695(83,174) + 20.65(79,320) = 2,471,200 \text{ kJ (Higher than 2,292,940)} \end{aligned}$$

By interpolation of the two results,

$$T_p = \mathbf{2307 \text{ K} = 2034^\circ\text{C}}$$

16-97 A mixture of H_2 and O_2 in a tank is ignited. The equilibrium composition of the product gases and the amount of heat transfer from the combustion chamber are to be determined.

Assumptions 1 The equilibrium composition consists of H_2O , H_2 , and O_2 . **2** The constituents of the mixture are ideal gases.

Analysis (a) The combustion equation can be written as

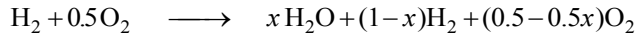

The equilibrium equation among H_2O , H_2 , and O_2 can be expressed as

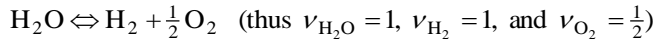

Total number of moles: $N_{\text{total}} = x + (1-x) + (0.5-0.5x) = 1.5-0.5x$

The equilibrium constant relation can be expressed as

$$K_p = \frac{N_{\text{H}_2}^{\nu_{\text{H}_2}} N_{\text{O}_2}^{\nu_{\text{O}_2}}}{N_{\text{H}_2\text{O}}^{\nu_{\text{H}_2\text{O}}}} \left(\frac{P}{N_{\text{total}}} \right)^{(\nu_{\text{H}_2} + \nu_{\text{O}_2} - \nu_{\text{H}_2\text{O}})}$$

From Table A-28, $\ln K_p = -3.812$ at 2800 K. Thus $K_p = 0.02210$. Substituting,

$$0.0221 = \frac{(1-x)(0.5-0.5x)^{0.5}}{x} \left(\frac{5}{1.5-0.5x} \right)^{1+0.5-1}$$

Solving for x , $x = 0.944$

Then the combustion equation and the equilibrium composition can be expressed as

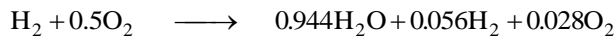

and **$0.944\text{H}_2\text{O} + 0.056\text{H}_2 + 0.028\text{O}_2$**

(b) The heat transfer can be determined from

$$-Q_{\text{out}} = \sum N_P (\bar{h}_f^\circ + \bar{h} - \bar{h}^\circ - P\bar{v})_P - \sum N_R (\bar{h}_f^\circ + \bar{h} - \bar{h}^\circ - P\bar{v})_R$$

Since $W = 0$ and both the reactants and the products are assumed to be ideal gases, all the internal energy and enthalpies depend on temperature only, and the $P\bar{v}$ terms in this equation can be replaced by $R_u T$. It yields

$$-Q_{\text{out}} = \sum N_P (\bar{h}_f^\circ + \bar{h}_{2800\text{K}} - \bar{h}_{298\text{K}} - R_u T)_P - \sum N_R (\bar{h}_f^\circ - R_u T)_R$$

since reactants are at the standard reference temperature of 25°C. From the tables,

Substance	\bar{h}_f° kJ/kmol	$\bar{h}_{298\text{K}}$ kJ/kmol	$\bar{h}_{2800\text{K}}$ kJ/kmol
H_2	0	8468	89,838
O_2	0	8682	98,826
H_2O	-241,820	9904	125,198

Substituting,

$$\begin{aligned} -Q_{\text{out}} &= 0.944(-241,820 + 125,198 - 9904 - 8.314 \times 2800) \\ &\quad + 0.056(0 + 89,838 - 8468 - 8.314 \times 2800) \\ &\quad + 0.028(0 + 98,826 - 8682 - 8.314 \times 2800) \\ &\quad - 1(0 - 8.314 \times 298) - 0.5(0 - 8.314 \times 298) \\ &= -132,574 \text{ kJ/kmol H}_2 \end{aligned}$$

or $Q_{\text{out}} = 132,574 \text{ kJ/mol H}_2$

The equilibrium constant for the reaction $\text{H}_2\text{O} \Leftrightarrow \text{OH} + \frac{1}{2}\text{H}_2$ is $\ln K_p = -3.763$, which is very close to the K_p value of the reaction considered. Therefore, it is not realistic to assume that no OH will be present in equilibrium mixture.

H_2O , H_2 , O_2
2800 K
5 atm

16-98 A mixture of H_2O and O_2 is heated to a high temperature. The equilibrium composition is to be determined.

Assumptions 1 The equilibrium composition consists of H_2O , OH , O_2 , and H_2 . **2** The constituents of the mixture are ideal gases.

Analysis The reaction equation during this process can be expressed as

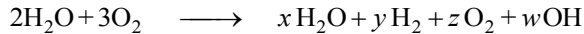

H_2O , OH , H_2 , O_2
3600 K
8 atm

Mass balances for hydrogen and oxygen yield

$$\text{H balance:} \quad 4 = 2x + 2y + w \quad (1)$$

$$\text{O balance:} \quad 8 = x + 2z + w \quad (2)$$

The mass balances provide us with only two equations with four unknowns, and thus we need to have two more equations (to be obtained from the K_P relations) to determine the equilibrium composition of the mixture. They are



The equilibrium constant for these two reactions at 3600 K are determined from Table A-28 to be

$$\ln K_{P1} = -1.392 \longrightarrow K_{P1} = 0.24858$$

$$\ln K_{P2} = -1.088 \longrightarrow K_{P2} = 0.33689$$

The K_P relations for these two simultaneous reactions are

$$K_{P1} = \frac{N_{\text{H}_2}^{v_{\text{H}_2}} N_{\text{O}_2}^{v_{\text{O}_2}}}{N_{\text{H}_2\text{O}}^{v_{\text{H}_2\text{O}}}} \left(\frac{P}{N_{\text{total}}} \right)^{(v_{\text{H}_2} + v_{\text{O}_2} - v_{\text{H}_2\text{O}})}$$

$$K_{P2} = \frac{N_{\text{H}_2}^{v_{\text{H}_2}} N_{\text{OH}}^{v_{\text{OH}}}}{N_{\text{H}_2\text{O}}^{v_{\text{H}_2\text{O}}}} \left(\frac{P}{N_{\text{total}}} \right)^{(v_{\text{H}_2} + v_{\text{OH}} - v_{\text{H}_2\text{O}})}$$

where

$$N_{\text{total}} = N_{\text{H}_2\text{O}} + N_{\text{H}_2} + N_{\text{O}_2} + N_{\text{OH}} = x + y + z + w$$

Substituting,

$$0.24858 = \frac{(y)(z)^{1/2}}{x} \left(\frac{8}{x + y + z + w} \right)^{1/2} \quad (3)$$

$$0.33689 = \frac{(w)(y)^{1/2}}{x} \left(\frac{8}{x + y + z + w} \right)^{1/2} \quad (4)$$

Solving Eqs. (1), (2), (3), and (4) simultaneously for the four unknowns x , y , z , and w yields

$$x = 1.371 \quad y = 0.1646 \quad z = 2.85 \quad w = 0.928$$

Therefore, the equilibrium composition becomes

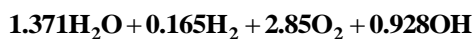

16-99 A mixture of CO_2 and O_2 is heated to a high temperature. The equilibrium composition is to be determined.

Assumptions 1 The equilibrium composition consists of CO_2 , CO , O_2 , and O . **2** The constituents of the mixture are ideal gases.

Analysis The reaction equation during this process can be expressed as



Mass balances for carbon and oxygen yield

$$\text{C balance:} \quad 3 = x + y \quad (1)$$

$$\text{O balance:} \quad 12 = 2x + y + 2z + w \quad (2)$$

$\text{CO}_2, \text{CO}, \text{O}_2, \text{O}$
3400 K
2 atm

The mass balances provide us with only two equations with four unknowns, and thus we need to have two more equations (to be obtained from the K_p relations) to determine the equilibrium composition of the mixture. They are



The equilibrium constant for these two reactions at 3400 K are determined from Table A-28 to be

$$\ln K_{p1} = 0.169 \longrightarrow K_{p1} = 1.184$$

$$\ln K_{p2} = -1.935 \longrightarrow K_{p2} = 0.1444$$

The K_p relations for these two simultaneous reactions are

$$K_{p1} = \frac{N_{\text{CO}}^{v_{\text{CO}}} N_{\text{O}_2}^{v_{\text{O}_2}}}{N_{\text{CO}_2}^{v_{\text{CO}_2}}} \left(\frac{P}{N_{\text{total}}} \right)^{(v_{\text{CO}} + v_{\text{O}_2} - v_{\text{CO}_2})}$$

$$K_{p2} = \frac{N_{\text{O}}^{v_{\text{O}}}}{N_{\text{O}_2}^{v_{\text{O}_2}}} \left(\frac{P}{N_{\text{total}}} \right)^{v_{\text{O}} - v_{\text{O}_2}}$$

where

$$N_{\text{total}} = N_{\text{CO}_2} + N_{\text{O}_2} + N_{\text{CO}} + N_{\text{O}} = x + y + z + w$$

Substituting,

$$1.184 = \frac{(y)(z)^{1/2}}{x} \left(\frac{2}{x + y + z + w} \right)^{1/2} \quad (3)$$

$$0.1444 = \frac{w^2}{z} \left(\frac{2}{x + y + z + w} \right)^{2-1} \quad (4)$$

Solving Eqs. (1), (2), (3), and (4) simultaneously for the four unknowns x , y , z , and w yields

$$x = 1.313 \quad y = 1.687 \quad z = 3.187 \quad w = 1.314$$

Thus the equilibrium composition is

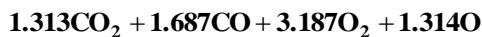



16-100 Problem 16-99 is reconsidered. The effect of pressure on the equilibrium composition by varying pressure from 1 atm to 10 atm is to be studied.

Analysis The problem is solved using EES, and the solution is given below.

"Given"

T=3400 [K]

"P=2 [atm]"

"The equilibrium constant for these two reactions at 2600 K are determined from Table A-28"

$K_{p1} = \exp(0.169)$

$K_{p2} = \exp(-1.935)$

"Analysis"

"Actual reaction: $3 \text{ CO}_2 + 3 \text{ O}_2 = \text{N}_{\text{CO}_2} \text{ CO}_2 + \text{N}_{\text{CO}} \text{ CO} + \text{N}_{\text{O}_2} \text{ O}_2 + \text{N}_{\text{O}} \text{ O}$ "

$3 = \text{N}_{\text{CO}_2} + \text{N}_{\text{CO}}$ "C balance"

$12 = 2 * \text{N}_{\text{CO}_2} + \text{N}_{\text{CO}} + 2 * \text{N}_{\text{O}_2} + \text{N}_{\text{O}}$ "O balance"

$\text{N}_{\text{total}} = \text{N}_{\text{CO}_2} + \text{N}_{\text{CO}} + \text{N}_{\text{O}_2} + \text{N}_{\text{O}}$

"Stoichiometric reaction 1: $\text{CO}_2 = \text{CO} + 1/2 \text{ O}_2$ "

"Stoichiometric coefficients for reaction 1"

$\text{nu}_{\text{CO}_2_1} = 1$

$\text{nu}_{\text{CO}}_1 = 1$

$\text{nu}_{\text{O}_2_1} = 1/2$

"Stoichiometric reaction 2: $\text{O}_2 = 2 \text{ O}$ "

"Stoichiometric coefficients for reaction 2"

$\text{nu}_{\text{O}_2_2} = 1$

$\text{nu}_{\text{O}}_2 = 2$

"K_p relations are"

$K_{p1} = (\text{N}_{\text{CO}}^{\text{nu}_{\text{CO}}_1} \text{N}_{\text{O}_2}^{\text{nu}_{\text{O}_2_1}}) / (\text{N}_{\text{CO}_2}^{\text{nu}_{\text{CO}_2_1}} (\text{P}/\text{N}_{\text{total}})^{(\text{nu}_{\text{CO}}_1 + \text{nu}_{\text{O}_2_1} - \text{nu}_{\text{CO}_2_1})})$

$K_{p2} = \text{N}_{\text{O}}^{\text{nu}_{\text{O}}_2} / (\text{N}_{\text{O}_2}^{\text{nu}_{\text{O}_2_2}} (\text{P}/\text{N}_{\text{total}})^{(\text{nu}_{\text{O}}_2 - \text{nu}_{\text{O}_2_2})})$

P _{atm} [atm]	b [kmol _{CO}]
1	1.968
2	1.687
3	1.52
4	1.404
5	1.315
6	1.244
7	1.186
8	1.136
9	1.093
10	1.055

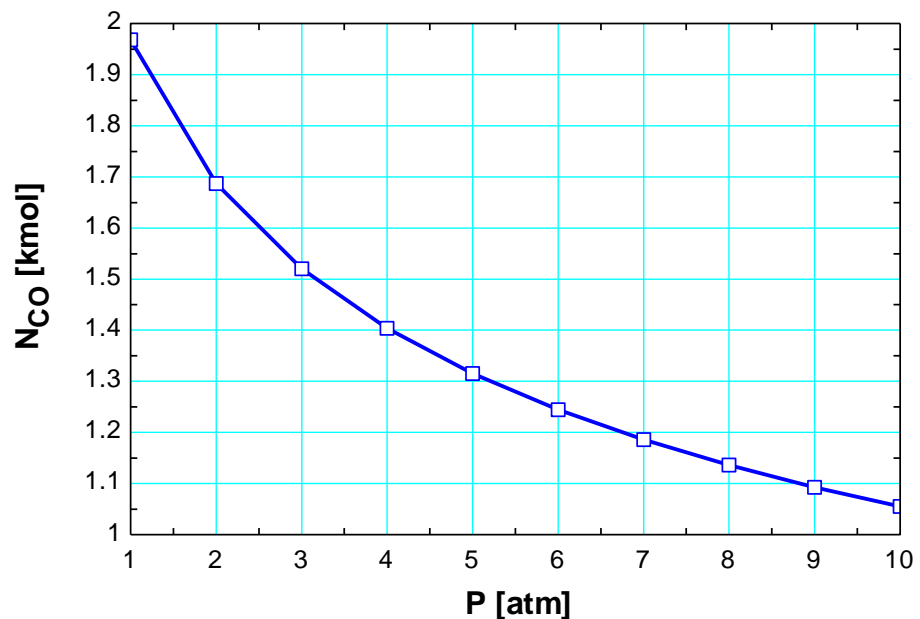

16-101 The \bar{h}_R at a specified temperature is to be determined using enthalpy and K_p data.

Assumptions Both the reactants and products are ideal gases.

Analysis (a) The complete combustion equation of H_2 can be expressed as

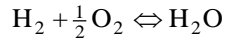

The \bar{h}_R of the combustion process of H_2 at 2400 K is the amount of energy released as one kmol of H_2 is burned in a steady-flow combustion chamber at a temperature of 2400 K, and can be determined from

$$\bar{h}_R = \sum N_P (\bar{h}_f^\circ + \bar{h} - \bar{h}^\circ)_P - \sum N_R (\bar{h}_f^\circ + \bar{h} - \bar{h}^\circ)_R$$

Assuming the H_2O , H_2 , and O_2 to be ideal gases, we have $h = h(T)$. From the tables,

Substance	\bar{h}_f° kJ/kmol	$\bar{h}_{298\text{ K}}$ kJ/kmol	$\bar{h}_{2400\text{ K}}$ kJ/kmol
H_2O	-241,820	9904	103,508
H_2	0	8468	75,383
O_2	0	8682	83,174

Substituting,

$$\begin{aligned} \bar{h}_R &= 1(-241,820 + 103,508 - 9904) \\ &\quad - 1(0 + 75,383 - 8468) \\ &\quad - 0.5(0 + 83,174 - 8682) \\ &= \mathbf{-252,377\text{ kJ/kmol}} \end{aligned}$$

(b) The \bar{h}_R value at 2400 K can be estimated by using K_p values at 2200 K and 2600 K (the closest two temperatures to 2400 K for which K_p data are available) from Table A-28,

$$\begin{aligned} \ln \frac{K_{P2}}{K_{P1}} &\cong \frac{\bar{h}_R}{R_u} \left(\frac{1}{T_1} - \frac{1}{T_2} \right) \quad \text{or} \quad \ln K_{P2} - \ln K_{P1} \cong \frac{\bar{h}_R}{R_u} \left(\frac{1}{T_1} - \frac{1}{T_2} \right) \\ 4.648 - 6.768 &\cong \frac{\bar{h}_R}{8.314\text{ kJ/kmol}\cdot\text{K}} \left(\frac{1}{2200\text{ K}} - \frac{1}{2600\text{ K}} \right) \\ \bar{h}_R &\cong \mathbf{-252,047\text{ kJ/kmol}} \end{aligned}$$



16-102 Problem 16-101 is reconsidered. The effect of temperature on the enthalpy of reaction using both methods by varying the temperature from 2000 to 3000 K is to be investigated.

Analysis The problem is solved using EES, and the solution is given below.

"Input Data"

```
T_prod=2400 [K]
DELTA_T_prod =25 [K]
R_u=8.314 [kJ/kmol-K]
T_prod_1 = T_prod - DELTA_T_prod
T_prod_2 = T_prod + DELTA_T_prod
```

"The combustion equation is $1 \text{ H}_2 + 0.5 \text{ O}_2 \Rightarrow 1 \text{ H}_2\text{O}$ "

"The enthalpy of reaction h_{bar}_R using enthalpy data is:"

```
h_bar_R_Enthalpy = HP - HR
HP = 1*Enthalpy(H2O,T=T_prod )
HR = 1*Enthalpy(H2,T=T_prod ) + 0.5*Enthalpy(O2,T=T_prod )
```

"The enthalpy of reaction h_{bar}_R using enthalpy data is found using the following equilibrium data:" "The following equations provide the specific Gibbs function ($g=h-Ts$) for each component as a function of its temperature at 1 atm pressure, 101.3 kPa"

```
g_H2O_1=Enthalpy(H2O,T=T_prod_1 )-T_prod_1 *Entropy(H2O,T=T_prod_1 ,P=101.3)
g_H2_1=Enthalpy(H2,T=T_prod_1 )-T_prod_1 *Entropy(H2,T=T_prod_1 ,P=101.3)
g_O2_1=Enthalpy(O2,T=T_prod_1 )-T_prod_1 *Entropy(O2,T=T_prod_1 ,P=101.3)
g_H2O_2=Enthalpy(H2O,T=T_prod_2 )-T_prod_2 *Entropy(H2O,T=T_prod_2 ,P=101.3)
g_H2_2=Enthalpy(H2,T=T_prod_2 )-T_prod_2 *Entropy(H2,T=T_prod_2 ,P=101.3)
g_O2_2=Enthalpy(O2,T=T_prod_2 )-T_prod_2 *Entropy(O2,T=T_prod_2 ,P=101.3)
```

"The standard-state (at 1 atm) Gibbs functions are"

```
DELTA_G_1 =1*g_H2O_1-0.5*g_O2_1-1*g_H2_1
DELTA_G_2 =1*g_H2O_2-0.5*g_O2_2-1*g_H2_2
```

"The equilibrium constants are given by Eq. 15-14."

```
K_p_1 = exp(-DELTA_G_1/(R_u*T_prod_1)) "From EES data"
```

```
K_P_2 = exp(-DELTA_G_2/(R_u*T_prod_2)) "From EES data"
```

"the enthalpy of reaction is estimated from the equilibrium constant K_p by using EQ 15-18 as:"

```
ln(K_P_2/K_P_1)=h_bar_R_Kp/R_u*(1/T_prod_1 - 1/T_prod_2)
PercentError = ABS((h_bar_R_Enthalpy - h_bar_R_Kp)/h_bar_R_Enthalpy)*Convert(, %)
```

Percent Error [%]	T_{prod} [K]	$h_{R,\text{Enthalpy}}$ [kJ/kmol]	$h_{R,Kp}$ [kJ/kmol]
0.0002739	2000	-251723	-251722
0.0002333	2100	-251920	-251919
0.000198	2200	-252096	-252095
0.0001673	2300	-252254	-252254
0.0001405	2400	-252398	-252398
0.0001173	2500	-252532	-252531
0.00009706	2600	-252657	-252657
0.00007957	2700	-252778	-252777
0.00006448	2800	-252897	-252896
0.00005154	2900	-253017	-253017
0.0000405	3000	-253142	-253142

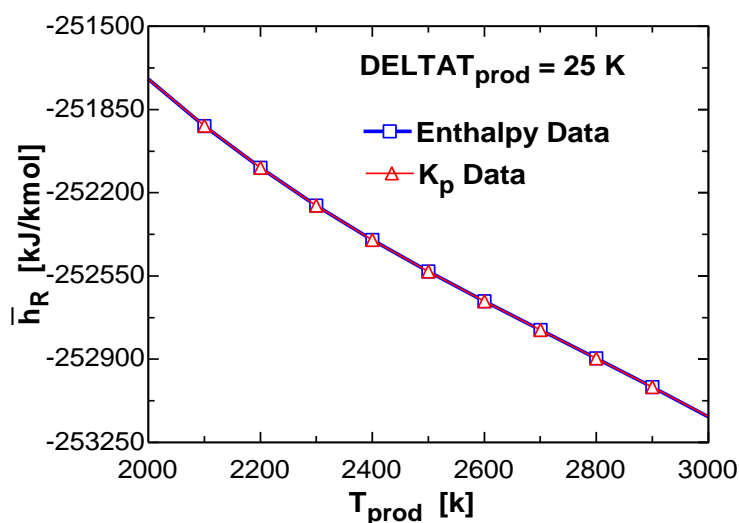

16-103 The K_p value of the dissociation process $O_2 \leftrightarrow 2O$ at a specified temperature is to be determined using the \bar{h}_R data and K_p value at a specified temperature.

Assumptions Both the reactants and products are ideal gases.

Analysis The \bar{h}_R and K_p data are related to each other by

$$\ln \frac{K_{p2}}{K_{p1}} \cong \frac{\bar{h}_R}{R_u} \left(\frac{1}{T_1} - \frac{1}{T_2} \right) \quad \text{or} \quad \ln K_{p2} - \ln K_{p1} \cong \frac{\bar{h}_R}{R_u} \left(\frac{1}{T_1} - \frac{1}{T_2} \right)$$

The \bar{h}_R of the specified reaction at 2200 K is the amount of energy released as one kmol of O_2 dissociates in a steady-flow combustion chamber at a temperature of 2200 K, and can be determined from

$$\bar{h}_R = \sum N_P (\bar{h}_f^\circ + \bar{h} - \bar{h}^\circ)_P - \sum N_R (\bar{h}_f^\circ + \bar{h} - \bar{h}^\circ)_R$$

Assuming the O_2 and O to be ideal gases, we have $h = h(T)$. From the tables,

Substance	\bar{h}_f° kJ/kmol	$\bar{h}_{298\text{ K}}$ kJ/kmol	$\bar{h}_{2200\text{ K}}$ kJ/kmol
O	249,190	6852	46,728
O_2	0	8682	75,484

Substituting,

$$\bar{h}_R = 2(249,190 + 46,728 - 6852) - 1(0 + 75,484 - 8682) = 511,330 \text{ kJ/kmol}$$

The K_p value at 2400 K can be estimated from the equation above by using this \bar{h}_R value and the K_p value at 2000 K which is $\ln K_{p1} = -14.622$,

$$\ln K_{p2} - (-14.622) = \frac{511,330 \text{ kJ/kmol}}{8.314 \text{ kJ/kmol} \cdot \text{K}} \left(\frac{1}{2000 \text{ K}} - \frac{1}{2400 \text{ K}} \right)$$

$$\ln K_{p2} = -9.497 \quad (\text{Table A - 28: } \ln K_{p2} = -9.497)$$

or

$$K_{p2} = 7.51 \times 10^{-5}$$

16-104 A 2-L bottle is filled with carbonated drink that is fully charged (saturated) with CO₂ gas. The volume that the CO₂ gas would occupy if it is released and stored in a container at room conditions is to be determined.

Assumptions 1 The liquid drink can be treated as water. **2** Both the CO₂ gas and the water vapor are ideal gases. **3** The CO₂ gas is weakly soluble in water and thus Henry's law is applicable.

Properties The saturation pressure of water at 17°C is 1.938 kPa (Table A-4). Henry's constant for CO₂ dissolved in water at 17°C (290 K) is $H = 1280$ bar (Table 16-2). Molar masses of CO₂ and water are 44.01 and 18.015 kg/kmol, respectively (Table A-1). The gas constant of CO₂ is 0.1889 kPa·m³/kg·K. Also, 1 bar = 100 kPa.

Analysis In the charging station, the CO₂ gas and water vapor mixture above the liquid will form a saturated mixture. Noting that the saturation pressure of water at 17°C is 1.938 kPa, the partial pressure of the CO₂ gas is

$$P_{\text{CO}_2, \text{gas side}} = P - P_{\text{vapor}} = P - P_{\text{sat @ 17°C}} = 600 - 1.938 = 598.06 \text{ kPa} = 5.9806 \text{ bar}$$

From Henry's law, the mole fraction of CO₂ in the liquid drink is determined to be

$$y_{\text{CO}_2, \text{liquid side}} = \frac{P_{\text{CO}_2, \text{gas side}}}{H} = \frac{5.9806 \text{ bar}}{1280 \text{ bar}} = 0.00467$$

Then the mole fraction of water in the drink becomes

$$y_{\text{water, liquid side}} = 1 - y_{\text{CO}_2, \text{liquid side}} = 1 - 0.00467 = 0.99533$$

The mass and mole fractions of a mixture are related to each other by

$$w_i = \frac{m_i}{m_m} = \frac{N_i M_i}{N_m M_m} = y_i \frac{M_i}{M_m}$$

where the apparent molar mass of the drink (liquid water - CO₂ mixture) is

$$\begin{aligned} M_m &= \sum y_i M_i = y_{\text{liquid water}} M_{\text{water}} + y_{\text{CO}_2} M_{\text{CO}_2} \\ &= 0.99533 \times 18.015 + 0.00467 \times 44.01 = 18.14 \text{ kg/kmol} \end{aligned}$$

Then the mass fraction of dissolved CO₂ in liquid drink becomes

$$w_{\text{CO}_2, \text{liquid side}} = y_{\text{CO}_2, \text{liquid side}} \frac{M_{\text{CO}_2}}{M_m} = 0.00467 \frac{44.01}{18.14} = 0.0113$$

Therefore, the mass of dissolved CO₂ in a 2 L ≈ 2 kg drink is

$$m_{\text{CO}_2} = w_{\text{CO}_2} m_m = 0.0113(2 \text{ kg}) = 0.0226 \text{ kg}$$

Then the volume occupied by this CO₂ at the room conditions of 20°C and 100 kPa becomes

$$v = \frac{mRT}{P} = \frac{(0.0226 \text{ kg})(0.1889 \text{ kPa} \cdot \text{m}^3 / \text{kg} \cdot \text{K})(293 \text{ K})}{100 \text{ kPa}} = \mathbf{0.0125 \text{ m}^3 = 12.5 \text{ L}}$$

Discussion Note that the amount of dissolved CO₂ in a 2-L pressurized drink is large enough to fill 6 such bottles at room temperature and pressure. Also, we could simplify the calculations by assuming the molar mass of carbonated drink to be the same as that of water, and take it to be 18 kg/kmol because of the very low mole fraction of CO₂ in the drink.



16-105 The natural log of the equilibrium constant as a function of temperature between 298 to 3000 K for the equilibrium reaction $\text{CO} + \text{H}_2\text{O} = \text{CO}_2 + \text{H}_2$ is to be tabulated and compared to those given in Table A-28

Analysis The K_p value of a reaction at a specified temperature can be determined from the Gibbs function data using

$$K_p = e^{-\Delta G^*(T)/R_u T} \quad \text{or} \quad \ln K_p = -\Delta G^*(T) / R_u T$$

where

$$\Delta G^*(T) = \nu_{\text{CO}_2} \bar{g}_{\text{CO}_2}^*(T) + \nu_{\text{H}_2} \bar{g}_{\text{H}_2}^*(T) - \nu_{\text{CO}} \bar{g}_{\text{CO}}^*(T) - \nu_{\text{H}_2\text{O}} \bar{g}_{\text{H}_2\text{O}}^*(T)$$

and the Gibbs functions are defined as

$$\bar{g}_{\text{CO}}^*(T_{\text{prod}}) = (\bar{h} - T_{\text{prod}} \bar{s})_{\text{CO}}$$

$$\bar{g}_{\text{H}_2\text{O}}^*(T_{\text{prod}}) = (\bar{h} - T_{\text{prod}} \bar{s})_{\text{H}_2\text{O}}$$

$$\bar{g}_{\text{CO}_2}^*(T_{\text{prod}}) = (\bar{h} - T_{\text{prod}} \bar{s})_{\text{CO}_2}$$

$$\bar{g}_{\text{H}_2}^*(T_{\text{prod}}) = (\bar{h} - T_{\text{prod}} \bar{s})_{\text{H}_2}$$

The copy of entire EES solution with resulting parametric table is given next:

```
{T_prod = 298 "[K]"}
```

```
R_u=8.314"[kJ/kmol-K]"
```

```
"The following equations provide the specific Gibbs function (g=h-Ts) for each component in the product gases as a function of its temperature, Tprod, at 1 atm pressure, 101.3 kPa"
```

```
"For T_prod:"
```

```
g_CO=Enthalpy(CO,T=T_prod)-T_prod*Entropy(CO,T=T_prod,P=101.3)
```

```
g_CO2=Enthalpy(CO2,T=T_prod)-T_prod*Entropy(CO2,T=T_prod,P=101.3)
```

```
g_H2=Enthalpy(H2,T=T_prod)-T_prod*Entropy(H2,T=T_prod,P=101.3)
```

```
g_H2O=Enthalpy(H2O,T=T_prod)-T_prod*Entropy(H2O,T=T_prod,P=101.3)
```

```
"The standard-state Gibbs function is"
```

```
DELTA_G = 1*g_CO2 + 1*g_H2 - 1*g_CO - 1*g_H2O
```

```
"The equilibrium constant is given by:"
```

```
K_p = exp(-DELTA_G / (R_u * T_prod))
```

```
lnK_p = ln(k_p)
```

T _{prod} [K]	ln K _p
298	11,58
500	4,939
1000	0,3725
1200	-0,3084
1400	-0,767
1600	-1,092
1800	-1,33
2000	-1,51
2200	-1,649
2400	-1,759
2600	-1,847
2800	-1,918
3000	-1,976



16-106 Ethyl alcohol C_2H_5OH (gas) is burned in a steady-flow adiabatic combustion chamber with 90 percent excess air. The adiabatic flame temperature of the products is to be determined and the adiabatic flame temperature as a function of the percent excess air is to be plotted.

Analysis The complete combustion reaction in this case can be written as

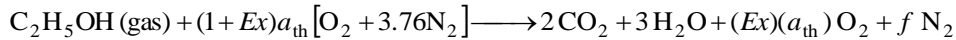

where a_{th} is the stoichiometric coefficient for air. The oxygen balance gives

$$1 + (1 + Ex)a_{\text{th}} \times 2 = 2 \times 2 + 3 \times 1 + (Ex)(a_{\text{th}}) \times 2$$

The reaction equation with products in equilibrium is

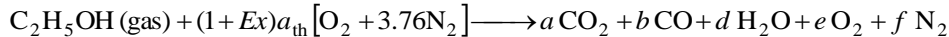

The coefficients are determined from the mass balances

Carbon balance: $2 = a + b$

Hydrogen balance: $6 = 2d \longrightarrow d = 3$

Oxygen balance: $1 + (1 + Ex)a_{\text{th}} \times 2 = a \times 2 + b + d + e \times 2$

Nitrogen balance: $(1 + Ex)a_{\text{th}} \times 3.76 = f$

Solving the above equations, we find the coefficients to be

$$Ex = 0.9, a_{\text{th}} = 3, a = 2, b = 0.00008644, d = 3, e = 2.7, f = 21.43$$

Then, we write the balanced reaction equation as

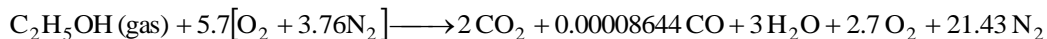

Total moles of products at equilibrium are

$$N_{\text{tot}} = 2 + 0.00008644 + 3 + 2.7 + 21.43 = 29.13$$

The assumed equilibrium reaction is

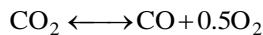

The K_p value of a reaction at a specified temperature can be determined from the Gibbs function data using

$$K_p = e^{-\Delta G^*(T)/R_u T} \quad \text{or} \quad \ln K_p = -\Delta G^*(T) / R_u T$$

where

$$\Delta G^*(T) = \nu_{CO} \bar{g}_{CO}^*(T_{\text{prod}}) + \nu_{O_2} \bar{g}_{O_2}^*(T_{\text{prod}}) - \nu_{CO_2} \bar{g}_{CO_2}^*(T_{\text{prod}})$$

and the Gibbs functions are defined as

$$\bar{g}_{CO}^*(T_{\text{prod}}) = (\bar{h} - T_{\text{prod}} \bar{s})_{CO}$$

$$\bar{g}_{O_2}^*(T_{\text{prod}}) = (\bar{h} - T_{\text{prod}} \bar{s})_{O_2}$$

$$\bar{g}_{CO_2}^*(T_{\text{prod}}) = (\bar{h} - T_{\text{prod}} \bar{s})_{CO_2}$$

The equilibrium constant is also given by

$$K_p = \frac{be^{0.5}}{a} \left(\frac{P}{N_{\text{tot}}} \right)^{1+0.5-1} = \frac{(0.00008644)(2.7)^{0.5}}{2} \left(\frac{1}{29.13} \right)^{0.5} = 0.00001316$$

A steady flow energy balance gives

$$H_R = H_P$$

where

$$H_R = \bar{h}_{f_{\text{fuel}@25^\circ\text{C}}}^o + 5.7\bar{h}_{\text{O}_2@25^\circ\text{C}} + 21.43\bar{h}_{\text{N}_2@25^\circ\text{C}}$$

$$= (-235,310 \text{ kJ/kmol}) + 5.7(0) + 21.43(0) = -235,310 \text{ kJ/kmol}$$

$$H_P = 2\bar{h}_{\text{CO}_2@T_{\text{prod}}} + 0.00008644\bar{h}_{\text{CO}@T_{\text{prod}}} + 3h_{\text{H}_2\text{O}@T_{\text{prod}}} + 2.7\bar{h}_{\text{O}_2@T_{\text{prod}}} + 21.43\bar{h}_{\text{N}_2@T_{\text{prod}}}$$

Solving the energy balance equation using EES, we obtain the adiabatic flame temperature to be

$$T_{\text{prod}} = \mathbf{1569\text{K}}$$

The copy of entire EES solution including parametric studies is given next:

"The product temperature is T_prod"

"The reactant temperature is:"

T_reac= 25+273.15 "[K]"

"For adiabatic combustion of 1 kmol of fuel: "

Q_out = 0 "[kJ]"

PercentEx = 90 "Percent excess air"

Ex = PercentEx/100 "EX = % Excess air/100"

P_prod = 101.3 "[kPa]"

R_u = 8.314 "[kJ/kmol-K]"

"The complete combustion reaction equation for excess air is:"

"C2H5OH(gas)+ (1+Ex)*A_th (O2 +3.76N2)=2 CO2 + 3 H2O +Ex*A_th O2 + f N2"

"Oxygen Balance for complete combustion:"

1 + (1+Ex)*A_th*2=2*2+3*1 + Ex*A_th*2

"The reaction equation for excess air and products in equilibrium is:"

"C2H5OH(gas)+ (1+Ex)*A_th (O2 +3.76N2)=a CO2 + b CO+ d H2O + e O2 + f N2"

"Carbon Balance:"

2=a + b

"Hydrogen Balance:"

6=2*d

"Oxygen Balance:"

1 + (1+Ex)*A_th*2=a*2+b + d + e*2

"Nitrogen Balance:"

(1+Ex)*A_th*3.76 = f

N_tot = a + b + d + e + f "Total kilomoles of products at equilibrium"

"The assumed equilibrium reaction is CO2=CO+0.5O2"

"The following equations provide the specific Gibbs function (g=h-Ts) for each component in the product gases as a function of its temperature, T_prod, at 1 atm pressure, 101.3 kPa"

g_CO2=Enthalpy(CO2,T=T_prod)-T_prod *Entropy(CO2,T=T_prod ,P=101.3)

g_CO=Enthalpy(CO,T=T_prod)-T_prod *Entropy(CO,T=T_prod ,P=101.3)

g_O2=Enthalpy(O2,T=T_prod)-T_prod *Entropy(O2,T=T_prod ,P=101.3)

"The standard-state Gibbs function is"

DELTA G = 1*g_CO+0.5*g_O2-1*g_CO2

"The equilibrium constant is given by Eq. 15-14."

K_P = exp(-DELTA G / (R_u*T_prod))

P=P_prod / 101.3 "atm"

"The equilibrium constant is also given by Eq. 15-15."

"K_P = (P/N_tot)^(1+0.5-1)*(b^1*e^0.5)/(a^1)"

sqrt(P/N_tot)*b *sqrt(e)=K_P *a

"The steady-flow energy balance is:"

$$H_R = Q_{out} + H_P$$

$$h_{bar_f_C2H5OHgas} = -235310 \text{ [kJ/kmol]}$$

$$H_R = 1 * (h_{bar_f_C2H5OHgas})$$

$$+ (1 + Ex) * A_{th} * ENTHALPY(O2, T=T_{reac}) + (1 + Ex) * A_{th} * 3.76 * ENTHALPY(N2, T=T_{reac}) \text{ [kJ/kmol]}$$

$$H_P = a * ENTHALPY(CO2, T=T_{prod}) + b * ENTHALPY(CO, T=T_{prod}) + d * ENTHALPY(H2O, T=T_{prod}) + e * ENTHALPY(O2, T=T_{prod}) + f * ENTHALPY(N2, T=T_{prod}) \text{ [kJ/kmol]}$$

PercentEx [%]	a	a _{th}	b	d	e	f	T _{prod} [K]
10	1.921	3	0.07868	3	0.3393	12.41	2191
20	1.97	3	0.03043	3	0.6152	13.54	2093
30	1.988	3	0.01212	3	0.9061	14.66	1996
40	1.995	3	0.004983	3	1.202	15.79	1907
50	1.998	3	0.002111	3	1.501	16.92	1826
60	1.999	3	0.0009184	3	1.8	18.05	1752
70	2	3	0.0004093	3	2.1	19.18	1685
80	2	3	0.0001863	3	2.4	20.3	1625
90	2	3	0.00008644	3	2.7	21.43	1569
100	2	3	0.00004081	3	3	22.56	1518

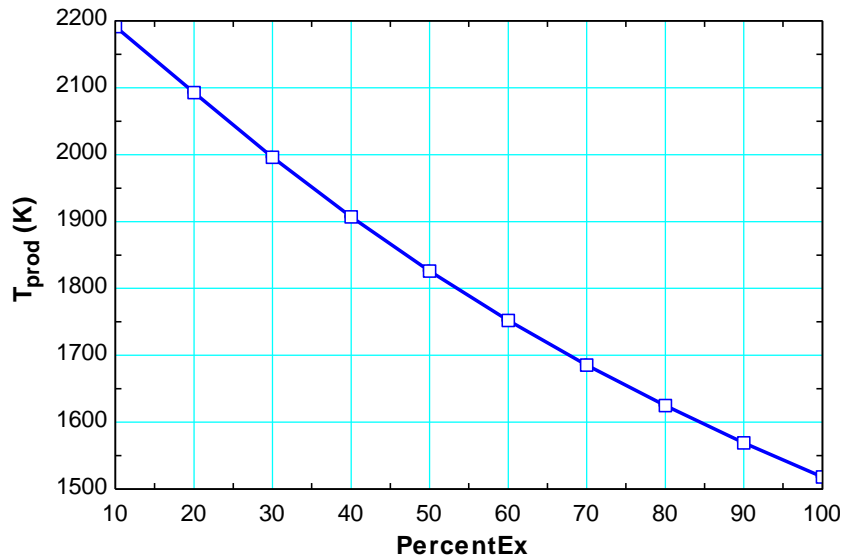

16-107 It is to be shown that when the three phases of a pure substance are in equilibrium, the specific Gibbs function of each phase is the same.

Analysis The total Gibbs function of the three phase mixture of a pure substance can be expressed as

$$G = m_s g_s + m_\ell g_\ell + m_g g_g$$

where the subscripts s , ℓ , and g indicate solid, liquid and gaseous phases. Differentiating by holding the temperature and pressure (thus the Gibbs functions, g) constant yields

$$dG = g_s dm_s + g_\ell dm_\ell + g_g dm_g$$

From conservation of mass,

$$dm_s + dm_\ell + dm_g = 0 \quad \longrightarrow \quad dm_s = -dm_\ell - dm_g$$

Substituting,

$$dG = -g_s(dm_\ell + dm_g) + g_\ell dm_\ell + g_g dm_g$$

Rearranging,

$$dG = (g_\ell - g_s)dm_\ell + (g_g - g_s)dm_g$$

For equilibrium, $dG = 0$. Also dm_ℓ and dm_g can be varied independently. Thus each term on the right hand side must be zero to satisfy the equilibrium criteria. It yields

$$g_\ell = g_s \quad \text{and} \quad g_g = g_s$$

Combining these two conditions gives the desired result,

$$g_\ell = g_s = g_g$$

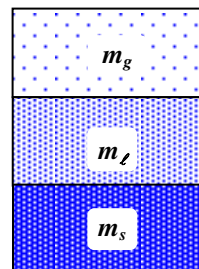

16-108 It is to be shown that when the two phases of a two-component system are in equilibrium, the specific Gibbs function of each phase of each component is the same.

Analysis The total Gibbs function of the two phase mixture can be expressed as

$$G = (m_{\ell 1} g_{\ell 1} + m_{g 1} g_{g 1}) + (m_{\ell 2} g_{\ell 2} + m_{g 2} g_{g 2})$$

where the subscripts ℓ and g indicate liquid and gaseous phases. Differentiating by holding the temperature and pressure (thus the Gibbs functions) constant yields

$$dG = g_{\ell 1} dm_{\ell 1} + g_{g 1} dm_{g 1} + g_{\ell 2} dm_{\ell 2} + g_{g 2} dm_{g 2}$$

From conservation of mass,

$$dm_{g 1} = -dm_{\ell 1} \quad \text{and} \quad dm_{g 2} = -dm_{\ell 2}$$

Substituting,

$$dG = (g_{\ell 1} - g_{g 1})dm_{\ell 1} + (g_{\ell 2} - g_{g 2})dm_{\ell 2}$$

For equilibrium, $dG = 0$. Also $dm_{\ell 1}$ and $dm_{\ell 2}$ can be varied independently. Thus each term on the right hand side must be zero to satisfy the equilibrium criteria. Then we have

$$g_{\ell 1} = g_{g 1} \quad \text{and} \quad g_{\ell 2} = g_{g 2}$$

which is the desired result.

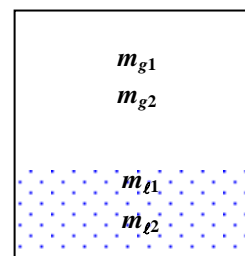

Fundamentals of Engineering (FE) Exam Problems

16-109 If the equilibrium constant for the reaction $\text{H}_2 + \frac{1}{2}\text{O}_2 \rightarrow \text{H}_2\text{O}$ is K , the equilibrium constant for the reaction $2\text{H}_2\text{O} \rightarrow 2\text{H}_2 + \text{O}_2$ at the same temperature is

- (a) $1/K$ (b) $1/(2K)$ (c) $2K$ (d) K^2 (e) $1/K^2$

Answer (e) $1/K^2$

16-110 If the equilibrium constant for the reaction $\text{CO} + \frac{1}{2}\text{O}_2 \rightarrow \text{CO}_2$ is K , the equilibrium constant for the reaction $\text{CO}_2 + 3\text{N}_2 \rightarrow \text{CO} + \frac{1}{2}\text{O}_2 + 3\text{N}_2$ at the same temperature is

- (a) $1/K$ (b) $1/(K + 3)$ (c) $4K$ (d) K (e) $1/K^2$

Answer (a) $1/K$

16-111 The equilibrium constant for the reaction $\text{H}_2 + \frac{1}{2}\text{O}_2 \rightarrow \text{H}_2\text{O}$ at 1 atm and 1500°C is given to be K . Of the reactions given below, all at 1500°C , the reaction that has a different equilibrium constant is

- (a) $\text{H}_2 + \frac{1}{2}\text{O}_2 \rightarrow \text{H}_2\text{O}$ at 5 atm,
 (b) $2\text{H}_2 + \text{O}_2 \rightarrow 2\text{H}_2\text{O}$ at 1 atm,
 (c) $\text{H}_2 + \text{O}_2 \rightarrow \text{H}_2\text{O} + \frac{1}{2}\text{O}_2$ at 2 atm,
 (d) $\text{H}_2 + \frac{1}{2}\text{O}_2 + 3\text{N}_2 \rightarrow \text{H}_2\text{O} + 3\text{N}_2$ at 5 atm,
 (e) $\text{H}_2 + \frac{1}{2}\text{O}_2 + 3\text{N}_2 \rightarrow \text{H}_2\text{O} + 3\text{N}_2$ at 1 atm,

Answer (b) $2\text{H}_2 + \text{O}_2 \rightarrow 2\text{H}_2\text{O}$ at 1 atm,

16-112 Of the reactions given below, the reaction whose equilibrium composition at a specified temperature is not affected by pressure is

- (a) $\text{H}_2 + \frac{1}{2}\text{O}_2 \rightarrow \text{H}_2\text{O}$
 (b) $\text{CO} + \frac{1}{2}\text{O}_2 \rightarrow \text{CO}_2$
 (c) $\text{N}_2 + \text{O}_2 \rightarrow 2\text{NO}$
 (d) $\text{N}_2 \rightarrow 2\text{N}$
 (e) all of the above.

Answer (c) $\text{N}_2 + \text{O}_2 \rightarrow 2\text{NO}$

16-113 Of the reactions given below, the reaction whose number of moles of products increases by the addition of inert gases into the reaction chamber at constant pressure and temperature is

- (a) $\text{H}_2 + \frac{1}{2}\text{O}_2 \rightarrow \text{H}_2\text{O}$
- (b) $\text{CO} + \frac{1}{2}\text{O}_2 \rightarrow \text{CO}_2$
- (c) $\text{N}_2 + \text{O}_2 \rightarrow 2\text{NO}$
- (d) $\text{N}_2 \rightarrow 2\text{N}$
- (e) none of the above.

Answer (d) $\text{N}_2 \rightarrow 2\text{N}$

16-114 Moist air is heated to a very high temperature. If the equilibrium composition consists of H_2O , O_2 , N_2 , OH , H_2 , and NO , the number of equilibrium constant relations needed to determine the equilibrium composition of the mixture is

- (a) 1
- (b) 2
- (c) 3
- (d) 4
- (e) 5

Answer (c) 3

16-115 Propane C_3H_8 is burned with air, and the combustion products consist of CO_2 , CO , H_2O , O_2 , N_2 , OH , H_2 , and NO . The number of equilibrium constant relations needed to determine the equilibrium composition of the mixture is

- (a) 1
- (b) 2
- (c) 3
- (d) 4
- (e) 5

Answer (d) 4

16-116 Consider a gas mixture that consists of three components. The number of independent variables that need to be specified to fix the state of the mixture is

- (a) 1
- (b) 2
- (c) 3
- (d) 4
- (e) 5

Answer (d) 4

16-117 The value of Henry's constant for CO₂ gas dissolved in water at 290 K is 12.8 MPa. Consider water exposed to air at 100 kPa that contains 3 percent CO₂ by volume. Under phase equilibrium conditions, the mole fraction of CO₂ gas dissolved in water at 290 K is

- (a) 2.3×10^{-4} (b) 3.0×10^{-4} (c) 0.80×10^{-4} (d) 2.2×10^{-4} (e) 5.6×10^{-4}

Answer (a) 2.3×10^{-4}

Solution Solved by EES Software. Solutions can be verified by copying-and-pasting the following lines on a blank EES screen. (Similar problems and their solutions can be obtained easily by modifying numerical values).

```
H=12.8 "MPa"
P=0.1 "MPa"
y_CO2_air=0.03
P_CO2_air=y_CO2_air*P
y_CO2_liquid=P_CO2_air/H
```

"Some Wrong Solutions with Common Mistakes:"

W1_yCO2=P_CO2_air*H "Multiplying by H instead of dividing by it"

W2_yCO2=P_CO2_air "Taking partial pressure in air"

16-118 The solubility of nitrogen gas in rubber at 25°C is 0.00156 kmol/m³·bar. When phase equilibrium is established, the density of nitrogen in a rubber piece placed in a nitrogen gas chamber at 300 kPa is

- (a) 0.005 kg/m³ (b) 0.018 kg/m³ (c) 0.047 kg/m³ (d) 0.13 kg/m³ (e) 0.28 kg/m³

Answer (d) 0.13 kg/m³

Solution Solved by EES Software. Solutions can be verified by copying-and-pasting the following lines on a blank EES screen. (Similar problems and their solutions can be obtained easily by modifying numerical values).

```
T=25 "C"
S=0.00156 "kmol/bar.m^3"
MM_N2=28 "kg/kmol"
S_mass=S*MM_N2 "kg/bar.m^3"
P_N2=3 "bar"
rho_solid=S_mass*P_N2
```

"Some Wrong Solutions with Common Mistakes:"

W1_density=S*P_N2 "Using solubility per kmol"

16-119 ... 16-122 Design and Essay Problems



Solutions Manual for
Thermodynamics: An Engineering Approach
8th Edition
Yunus A. Çengel, Michael A. Boles
McGraw-Hill, 2015

Chapter 17

COMPRESSIBLE FLOW

PROPRIETARY AND CONFIDENTIAL

This Manual is the proprietary property of McGraw-Hill Education and protected by copyright and other state and federal laws. By opening and using this Manual the user agrees to the following restrictions, and if the recipient does not agree to these restrictions, the Manual should be promptly returned unopened to McGraw-Hill Education: **This Manual is being provided only to authorized professors and instructors for use in preparing for the classes using the affiliated textbook. No other use or distribution of this Manual is permitted. This Manual may not be sold and may not be distributed to or used by any student or other third party. No part of this Manual may be reproduced, displayed or distributed in any form or by any means, electronic or otherwise, without the prior written permission of McGraw-Hill Education.**

Stagnation Properties

17-1C We are to discuss the temperature change from an airplane's nose to far away from the aircraft.

Analysis The temperature of the air **rises as it approaches the nose because of the stagnation process.**

Discussion In the frame of reference moving with the aircraft, the air decelerates from high speed to zero at the nose (stagnation point), and this causes the air temperature to rise.

17-2C We are to define dynamic temperature.

Analysis *Dynamic temperature is the temperature rise of a fluid during a stagnation process.*

Discussion When a gas decelerates from high speed to zero speed at a stagnation point, the temperature of the gas rises.

17-3C We are to discuss the measurement of flowing air temperature with a probe – is there significant error?

Analysis **No, there is not significant error**, because the velocities encountered in air-conditioning applications are very low, and thus the static and the stagnation temperatures are practically identical.

Discussion If the air stream were supersonic, however, the error would indeed be significant.

17-4 Air flows through a device. The stagnation temperature and pressure of air and its velocity are specified. The static pressure and temperature of air are to be determined.

Assumptions **1** The stagnation process is isentropic. **2** Air is an ideal gas.

Properties The properties of air at an anticipated average temperature of 600 K are $c_p = 1.051 \text{ kJ/kg}\cdot\text{K}$ and $k = 1.376$.

Analysis The static temperature and pressure of air are determined from

$$T = T_0 - \frac{V^2}{2c_p} = 673.2 - \frac{(570 \text{ m/s})^2}{2 \times 1.051 \text{ kJ/kg} \cdot \text{K}} \left(\frac{1 \text{ kJ/kg}}{1000 \text{ m}^2/\text{s}^2} \right) = 518.6 \text{ K} \cong \mathbf{519 \text{ K}}$$

and

$$P_2 = P_{02} \left(\frac{T_2}{T_{02}} \right)^{k/(k-1)} = (0.6 \text{ MPa}) \left(\frac{518.6 \text{ K}}{673.2 \text{ K}} \right)^{1.376/(1.376-1)} = \mathbf{0.231 \text{ MPa}}$$

Discussion Note that the stagnation properties can be significantly different than thermodynamic properties.

17-5 Air at 320 K is flowing in a duct. The temperature that a stationary probe inserted into the duct will read is to be determined for different air velocities.

Assumptions The stagnation process is isentropic.

Properties The specific heat of air at room temperature is $c_p = 1.005 \text{ kJ/kg}\cdot\text{K}$.

Analysis The air which strikes the probe will be brought to a complete stop, and thus it will undergo a stagnation process. The thermometer will sense the temperature of this stagnated air, which is the stagnation temperature, T_0 . It is

determined from $T_0 = T + \frac{V^2}{2c_p}$. The results for each case are calculated below:

$$(a) \quad T_0 = 320 \text{ K} + \frac{(1 \text{ m/s})^2}{2 \times 1.005 \text{ kJ/kg}\cdot\text{K}} \left(\frac{1 \text{ kJ/kg}}{1000 \text{ m}^2/\text{s}^2} \right) = \mathbf{320.0K}$$

$$(b) \quad T_0 = 320 \text{ K} + \frac{(10 \text{ m/s})^2}{2 \times 1.005 \text{ kJ/kg}\cdot\text{K}} \left(\frac{1 \text{ kJ/kg}}{1000 \text{ m}^2/\text{s}^2} \right) = \mathbf{320.1K}$$

$$(c) \quad T_0 = 320 \text{ K} + \frac{(100 \text{ m/s})^2}{2 \times 1.005 \text{ kJ/kg}\cdot\text{K}} \left(\frac{1 \text{ kJ/kg}}{1000 \text{ m}^2/\text{s}^2} \right) = \mathbf{325.0K}$$

$$(d) \quad T_0 = 320 \text{ K} + \frac{(1000 \text{ m/s})^2}{2 \times 1.005 \text{ kJ/kg}\cdot\text{K}} \left(\frac{1 \text{ kJ/kg}}{1000 \text{ m}^2/\text{s}^2} \right) = \mathbf{817.5K}$$

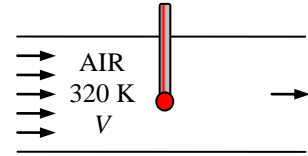

Discussion Note that the stagnation temperature is nearly identical to the thermodynamic temperature at low velocities, but the difference between the two is significant at high velocities.

17-6 The states of different substances and their velocities are specified. The stagnation temperature and stagnation pressures are to be determined.

Assumptions 1 The stagnation process is isentropic. 2 Helium and nitrogen are ideal gases.

Analysis (a) Helium can be treated as an ideal gas with $c_p = 5.1926 \text{ kJ/kg}\cdot\text{K}$ and $k = 1.667$. Then the stagnation temperature and pressure of helium are determined from

$$T_0 = T + \frac{V^2}{2c_p} = 50^\circ\text{C} + \frac{(240 \text{ m/s})^2}{2 \times 5.1926 \text{ kJ/kg}\cdot^\circ\text{C}} \left(\frac{1 \text{ kJ/kg}}{1000 \text{ m}^2/\text{s}^2} \right) = \mathbf{55.5^\circ\text{C}}$$

$$P_0 = P \left(\frac{T_0}{T} \right)^{k/(k-1)} = (0.25 \text{ MPa}) \left(\frac{328.7 \text{ K}}{323.2 \text{ K}} \right)^{1.667/(1.667-1)} = \mathbf{0.261 \text{ MPa}}$$

(b) Nitrogen can be treated as an ideal gas with $c_p = 1.039 \text{ kJ/kg}\cdot\text{K}$ and $k = 1.400$. Then the stagnation temperature and pressure of nitrogen are determined from

$$T_0 = T + \frac{V^2}{2c_p} = 50^\circ\text{C} + \frac{(300 \text{ m/s})^2}{2 \times 1.039 \text{ kJ/kg}\cdot^\circ\text{C}} \left(\frac{1 \text{ kJ/kg}}{1000 \text{ m}^2/\text{s}^2} \right) = \mathbf{93.3^\circ\text{C}}$$

$$P_0 = P \left(\frac{T_0}{T} \right)^{k/(k-1)} = (0.15 \text{ MPa}) \left(\frac{366.5 \text{ K}}{323.2 \text{ K}} \right)^{1.4/(1.4-1)} = \mathbf{0.233 \text{ MPa}}$$

(c) Steam can be treated as an ideal gas with $c_p = 1.865 \text{ kJ/kg}\cdot\text{K}$ and $k = 1.329$. Then the stagnation temperature and pressure of steam are determined from

$$T_0 = T + \frac{V^2}{2c_p} = 350^\circ\text{C} + \frac{(480 \text{ m/s})^2}{2 \times 1.865 \text{ kJ/kg}\cdot^\circ\text{C}} \left(\frac{1 \text{ kJ/kg}}{1000 \text{ m}^2/\text{s}^2} \right) = \mathbf{411.8^\circ\text{C} = 685 \text{ K}}$$

$$P_0 = P \left(\frac{T_0}{T} \right)^{k/(k-1)} = (0.1 \text{ MPa}) \left(\frac{685 \text{ K}}{623.2 \text{ K}} \right)^{1.329/(1.329-1)} = \mathbf{0.147 \text{ MPa}}$$

Discussion Note that the stagnation properties can be significantly different than thermodynamic properties.

17-7 The state of air and its velocity are specified. The stagnation temperature and stagnation pressure of air are to be determined.

Assumptions 1 The stagnation process is isentropic. 2 Air is an ideal gas.

Properties The properties of air at room temperature are $c_p = 1.005 \text{ kJ/kg}\cdot\text{K}$ and $k = 1.4$.

Analysis The stagnation temperature of air is determined from

$$T_0 = T + \frac{V^2}{2c_p} = 238 \text{ K} + \frac{(325 \text{ m/s})^2}{2 \times 1.005 \text{ kJ/kg}\cdot\text{K}} \left(\frac{1 \text{ kJ/kg}}{1000 \text{ m}^2/\text{s}^2} \right) = 290.5 \cong \mathbf{291 \text{ K}}$$

Other stagnation properties at the specified state are determined by considering an isentropic process between the specified state and the stagnation state,

$$P_0 = P \left(\frac{T_0}{T} \right)^{k/(k-1)} = (36 \text{ kPa}) \left(\frac{290.5 \text{ K}}{238 \text{ K}} \right)^{1.4/(1.4-1)} = 72.37 \text{ kPa} \cong \mathbf{72.4 \text{ kPa}}$$

Discussion Note that the stagnation properties can be significantly different than thermodynamic properties.

17-8E Steam flows through a device. The stagnation temperature and pressure of steam and its velocity are specified. The static pressure and temperature of the steam are to be determined.

Assumptions 1 The stagnation process is isentropic. 2 Steam is an ideal gas.

Properties Steam can be treated as an ideal gas with $c_p = 0.4455 \text{ Btu/lbm}\cdot\text{R}$ and $k = 1.329$.

Analysis The static temperature and pressure of steam are determined from

$$T = T_0 - \frac{V^2}{2c_p} = 700^\circ\text{F} - \frac{(900 \text{ ft/s})^2}{2 \times 0.4455 \text{ Btu/lbm}\cdot^\circ\text{F}} \left(\frac{1 \text{ Btu/lbm}}{25,037 \text{ ft}^2/\text{s}^2} \right) = \mathbf{663.7^\circ\text{F}}$$

$$P = P_0 \left(\frac{T}{T_0} \right)^{k/(k-1)} = (120 \text{ psia}) \left(\frac{1123.7 \text{ R}}{1160 \text{ R}} \right)^{1.329/(1.329-1)} = \mathbf{105.5 \text{ psia}}$$

Discussion Note that the stagnation properties can be significantly different than thermodynamic properties.

17-9 The inlet stagnation temperature and pressure and the exit stagnation pressure of air flowing through a compressor are specified. The power input to the compressor is to be determined.

Assumptions 1 The compressor is isentropic. 2 Air is an ideal gas.

Properties The properties of air at room temperature are $c_p = 1.005 \text{ kJ/kg}\cdot\text{K}$ and $k = 1.4$.

Analysis The exit stagnation temperature of air T_{02} is determined from

$$T_{02} = T_{01} \left(\frac{P_{02}}{P_{01}} \right)^{(k-1)/k} = (308.2 \text{ K}) \left(\frac{900}{100} \right)^{(1.4-1)/1.4} = 577.4 \text{ K}$$

From the energy balance on the compressor,

$$\dot{W}_{\text{in}} = \dot{m}(h_{20} - h_{01})$$

or,

$$\dot{W}_{\text{in}} = \dot{m}c_p(T_{02} - T_{01}) = (0.04 \text{ kg/s})(1.005 \text{ kJ/kg}\cdot\text{K})(577.4 - 308.2)\text{K} = \mathbf{10.8 \text{ kW}}$$

Discussion Note that the stagnation properties can be used conveniently in the energy equation.

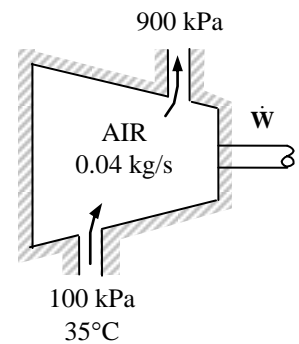

17-10 The inlet stagnation temperature and pressure and the exit stagnation pressure of products of combustion flowing through a gas turbine are specified. The power output of the turbine is to be determined.

Assumptions 1 The expansion process is isentropic. 2 Products of combustion are ideal gases.

Properties The properties of products of combustion are $c_p = 1.157 \text{ kJ/kg}\cdot\text{K}$, $R = 0.287 \text{ kJ/kg}\cdot\text{K}$, and $k = 1.33$.

Analysis The exit stagnation temperature T_{02} is determined to be

$$T_{02} = T_{01} \left(\frac{P_{02}}{P_{01}} \right)^{(k-1)/k} = (963.2 \text{ K}) \left(\frac{0.1}{0.75} \right)^{(1.33-1)/1.33} = 584.2 \text{ K}$$

Also,

$$\begin{aligned} c_p = kc_v = k(c_p - R) &\longrightarrow c_p = \frac{kR}{k-1} \\ &= \frac{1.33(0.287 \text{ kJ/kg}\cdot\text{K})}{1.33-1} \\ &= 1.157 \text{ kJ/kg}\cdot\text{K} \end{aligned}$$

From the energy balance on the turbine,

$$-w_{\text{out}} = (h_{20} - h_{01})$$

$$\text{or, } w_{\text{out}} = c_p(T_{01} - T_{02}) = (1.157 \text{ kJ/kg}\cdot\text{K})(963.2 - 584.2)\text{K} = 438.5 \text{ kJ/kg} \cong \mathbf{439 \text{ kJ/kg}}$$

Discussion Note that the stagnation properties can be used conveniently in the energy equation.

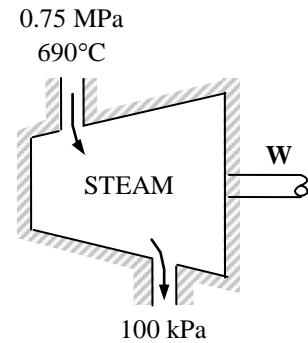

Speed of Sound and Mach Number

17-11C We are to define and discuss sound and how it is generated and how it travels.

Analysis *Sound is an infinitesimally small pressure wave. It is generated by a small disturbance in a medium. It travels by wave propagation. Sound waves cannot travel in a vacuum.*

Discussion Electromagnetic waves, like light and radio waves, can travel in a vacuum, but sound cannot.

17-12C We are to discuss whether sound travels faster in warm or cool air.

Analysis Sound travels faster in **warm (higher temperature) air** since $c = \sqrt{kRT}$.

Discussion On the microscopic scale, we can imagine the air molecules moving around at higher speed in warmer air, leading to higher propagation of disturbances.

17-13C We are to compare the speed of sound in air, helium, and argon.

Analysis **Sound travels fastest in helium**, since $c = \sqrt{kRT}$ and helium has the highest kR value. It is about 0.40 for air, 0.35 for argon, and 3.46 for helium.

Discussion We are assuming, of course, that these gases behave as ideal gases – a good approximation at room temperature.

17-14C We are to compare the speed of sound in air at two different pressures, but the same temperature.

Analysis Air at specified conditions will behave like an ideal gas, and *the speed of sound in an ideal gas depends on temperature only*. Therefore, **the speed of sound is the same in both mediums**.

Discussion If the temperature were different, however, the speed of sound would be different.

17-15C We are to examine whether the Mach number remains constant in constant-velocity flow.

Analysis In general, **no**, because the Mach number also depends on the speed of sound in gas, which depends on the temperature of the gas. **The Mach number remains constant only if the temperature and the velocity are constant.**

Discussion It turns out that the speed of sound is not a strong function of pressure. In fact, it is not a function of pressure at all for an ideal gas.

17-16C We are to state whether the propagation of sound waves is an isentropic process.

Analysis **Yes, the propagation of sound waves is nearly isentropic.** Because the amplitude of an ordinary sound wave is very small, and it does not cause any significant change in temperature and pressure.

Discussion No process is truly isentropic, but the increase of entropy due to sound propagation is negligibly small.

17-17C We are to discuss sonic velocity – specifically, whether it is constant or it changes.

Analysis The *sonic speed* in a medium **depends on the properties of the medium, and it changes as the properties of the medium change.**

Discussion The most common example is the change in speed of sound due to temperature change.

17-18 The Mach number of a passenger plane for specified limiting operating conditions is to be determined.

Assumptions Air is an ideal gas with constant specific heats at room temperature.

Properties The gas constant of air is $R = 0.287 \text{ kJ/kg}\cdot\text{K}$. Its specific heat ratio at room temperature is $k = 1.4$.

Analysis From the speed of sound relation

$$c = \sqrt{kRT} = \sqrt{(1.4)(0.287 \text{ kJ/kg}\cdot\text{K})(-60 + 273 \text{ K})\left(\frac{1000 \text{ m}^2/\text{s}^2}{1 \text{ kJ/kg}}\right)} = 293 \text{ m/s}$$

Thus, the Mach number corresponding to the maximum cruising speed of the plane is

$$\text{Ma} = \frac{V_{\max}}{c} = \frac{(945/3.6) \text{ m/s}}{293 \text{ m/s}} = \mathbf{0.897}$$

Discussion Note that this is a subsonic flight since $\text{Ma} < 1$. Also, using a k value at -60°C would give practically the same result.

17-19 Carbon dioxide flows through a nozzle. The inlet temperature and velocity and the exit temperature of CO_2 are specified. The Mach number is to be determined at the inlet and exit of the nozzle.

Assumptions **1** CO_2 is an ideal gas with constant specific heats at room temperature. **2** This is a steady-flow process.

Properties The gas constant of carbon dioxide is $R = 0.1889 \text{ kJ/kg}\cdot\text{K}$. Its constant pressure specific heat and specific heat ratio at room temperature are $c_p = 0.8439 \text{ kJ/kg}\cdot\text{K}$ and $k = 1.288$.

Analysis (a) At the inlet

$$c_1 = \sqrt{k_1 R T_1} = \sqrt{(1.288)(0.1889 \text{ kJ/kg}\cdot\text{K})(1200 \text{ K}) \left(\frac{1000 \text{ m}^2/\text{s}^2}{1 \text{ kJ/kg}} \right)} = 540.3 \text{ m/s}$$

Thus,

$$\text{Ma}_1 = \frac{V_1}{c_1} = \frac{50 \text{ m/s}}{540.3 \text{ m/s}} = \mathbf{0.0925}$$

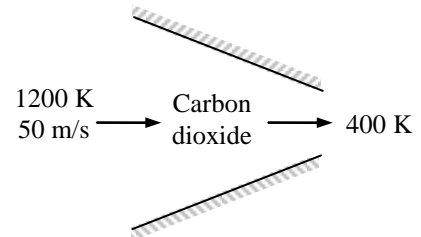

(b) At the exit,

$$c_2 = \sqrt{k_2 R T_2} = \sqrt{(1.288)(0.1889 \text{ kJ/kg}\cdot\text{K})(400 \text{ K}) \left(\frac{1000 \text{ m}^2/\text{s}^2}{1 \text{ kJ/kg}} \right)} = 312.0 \text{ m/s}$$

The nozzle exit velocity is determined from the steady-flow energy balance relation,

$$0 = h_2 - h_1 + \frac{V_2^2 - V_1^2}{2} \rightarrow 0 = c_p(T_2 - T_1) + \frac{V_2^2 - V_1^2}{2}$$

$$0 = (0.8439 \text{ kJ/kg}\cdot\text{K})(400 - 1200 \text{ K}) + \frac{V_2^2 - (50 \text{ m/s})^2}{2} \left(\frac{1 \text{ kJ/kg}}{1000 \text{ m}^2/\text{s}^2} \right) \rightarrow V_2 = 1163 \text{ m/s}$$

Thus,

$$\text{Ma}_2 = \frac{V_2}{c_2} = \frac{1163 \text{ m/s}}{312 \text{ m/s}} = \mathbf{3.73}$$

Discussion The specific heats and their ratio k change with temperature, and the accuracy of the results can be improved by accounting for this variation. Using EES (or another property database):

$$\text{At } 1200 \text{ K: } c_p = 1.278 \text{ kJ/kg}\cdot\text{K}, k = 1.173 \rightarrow c_1 = 516 \text{ m/s}, V_1 = 50 \text{ m/s}, \text{Ma}_1 = 0.0969$$

$$\text{At } 400 \text{ K: } c_p = 0.9383 \text{ kJ/kg}\cdot\text{K}, k = 1.252 \rightarrow c_2 = 308 \text{ m/s}, V_2 = 1356 \text{ m/s}, \text{Ma}_2 = 4.41$$

Therefore, the constant specific heat assumption results in an error of **4.5%** at the inlet and **15.5%** at the exit in the Mach number, which are significant.

17-20 Nitrogen flows through a heat exchanger. The inlet temperature, pressure, and velocity and the exit pressure and velocity are specified. The Mach number is to be determined at the inlet and exit of the heat exchanger.

Assumptions 1 N_2 is an ideal gas. 2 This is a steady-flow process. 3 The potential energy change is negligible.

Properties The gas constant of N_2 is $R = 0.2968 \text{ kJ/kg}\cdot\text{K}$. Its constant pressure specific heat and specific heat ratio at room temperature are $c_p = 1.040 \text{ kJ/kg}\cdot\text{K}$ and $k = 1.4$.

Analysis For the inlet,

$$c_1 = \sqrt{k_1 RT_1} = \sqrt{(1.400)(0.2968 \text{ kJ/kg}\cdot\text{K})(283 \text{ K}) \left(\frac{1000 \text{ m}^2/\text{s}^2}{1 \text{ kJ/kg}} \right)} = 342.9 \text{ m/s}$$

Thus,

$$\text{Ma}_1 = \frac{V_1}{c_1} = \frac{100 \text{ m/s}}{342.9 \text{ m/s}} = \mathbf{0.292}$$

From the energy balance on the heat exchanger,

$$q_{\text{in}} = c_p(T_2 - T_1) + \frac{V_2^2 - V_1^2}{2}$$

$$120 \text{ kJ/kg} = (1.040 \text{ kJ/kg}\cdot\text{K})(T_2 - 10^\circ\text{C}) + \frac{(200 \text{ m/s})^2 - (100 \text{ m/s})^2}{2} \left(\frac{1 \text{ kJ/kg}}{1000 \text{ m}^2/\text{s}^2} \right)$$

It yields

$$T_2 = 111^\circ\text{C} = 384 \text{ K}$$

$$c_2 = \sqrt{k_2 RT_2} = \sqrt{(1.4)(0.2968 \text{ kJ/kg}\cdot\text{K})(384 \text{ K}) \left(\frac{1000 \text{ m}^2/\text{s}^2}{1 \text{ kJ/kg}} \right)} = 399 \text{ m/s}$$

Thus,

$$\text{Ma}_2 = \frac{V_2}{c_2} = \frac{200 \text{ m/s}}{399 \text{ m/s}} = \mathbf{0.501}$$

Discussion The specific heats and their ratio k change with temperature, and the accuracy of the results can be improved by accounting for this variation. Using EES (or another property database):

$$\text{At } 10^\circ\text{C} : c_p = 1.038 \text{ kJ/kg}\cdot\text{K}, k = 1.400 \rightarrow c_1 = 343 \text{ m/s}, V_1 = 100 \text{ m/s}, \text{Ma}_1 = 0.292$$

$$\text{At } 111^\circ\text{C} : c_p = 1.041 \text{ kJ/kg}\cdot\text{K}, k = 1.399 \rightarrow c_2 = 399 \text{ m/s}, V_2 = 200 \text{ m/s}, \text{Ma}_2 = 0.501$$

Therefore, the constant specific heat assumption results in an error of **4.5%** at the inlet and **15.5%** at the exit in the Mach number, which are almost identical to the values obtained assuming constant specific heats.

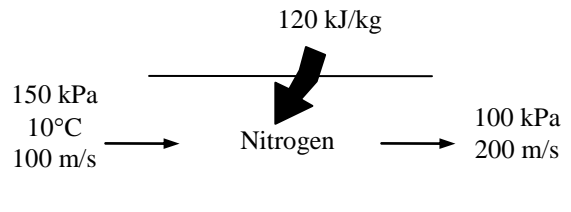

17-21 The speed of sound in refrigerant-134a at a specified state is to be determined.

Assumptions R-134a is an ideal gas with constant specific heats at room temperature.

Properties The gas constant of R-134a is $R = 0.08149 \text{ kJ/kg}\cdot\text{K}$. Its specific heat ratio at room temperature is $k = 1.108$.

Analysis From the ideal-gas speed of sound relation,

$$c = \sqrt{kRT} = \sqrt{(1.108)(0.08149 \text{ kJ/kg}\cdot\text{K})(60 + 273 \text{ K})\left(\frac{1000 \text{ m}^2/\text{s}^2}{1 \text{ kJ/kg}}\right)} = \mathbf{173 \text{ m/s}}$$

Discussion Note that the speed of sound is independent of pressure for ideal gases.

17-22 The Mach number of an aircraft and the speed of sound in air are to be determined at two specified temperatures.

Assumptions Air is an ideal gas with constant specific heats at room temperature.

Properties The gas constant of air is $R = 0.287 \text{ kJ/kg}\cdot\text{K}$. Its specific heat ratio at room temperature is $k = 1.4$.

Analysis From the definitions of the speed of sound and the Mach number,

(a) At 300 K,

$$c = \sqrt{kRT} = \sqrt{(1.4)(0.287 \text{ kJ/kg}\cdot\text{K})(300 \text{ K})\left(\frac{1000 \text{ m}^2/\text{s}^2}{1 \text{ kJ/kg}}\right)} = \mathbf{347 \text{ m/s}}$$

and $\text{Ma} = \frac{V}{c} = \frac{330 \text{ m/s}}{347 \text{ m/s}} = \mathbf{0.951}$

(b) At 800 K,

$$c = \sqrt{kRT} = \sqrt{(1.4)(0.287 \text{ kJ/kg}\cdot\text{K})(800 \text{ K})\left(\frac{1000 \text{ m}^2/\text{s}^2}{1 \text{ kJ/kg}}\right)} = \mathbf{567 \text{ m/s}}$$

and $\text{Ma} = \frac{V}{c} = \frac{330 \text{ m/s}}{567 \text{ m/s}} = \mathbf{0.582}$

Discussion Note that a constant Mach number does not necessarily indicate constant speed. The Mach number of a rocket, for example, will be increasing even when it ascends at constant speed. Also, the specific heat ratio k changes with temperature.

17-23E Steam flows through a device at a specified state and velocity. The Mach number of steam is to be determined assuming ideal gas behavior.

Assumptions Steam is an ideal gas with constant specific heats.

Properties The gas constant of steam is $R = 0.1102 \text{ Btu/lbm}\cdot\text{R}$. Its specific heat ratio is given to be $k = 1.3$.

Analysis From the ideal-gas speed of sound relation,

$$c = \sqrt{kRT} = \sqrt{(1.3)(0.1102 \text{ Btu/lbm}\cdot\text{R})(1160 \text{ R}) \left(\frac{25,037 \text{ ft}^2/\text{s}^2}{1 \text{ Btu/lbm}} \right)} = 2040 \text{ ft/s}$$

Thus,

$$\text{Ma} = \frac{V}{c} = \frac{900 \text{ ft/s}}{2040 \text{ ft/s}} = \mathbf{0.441}$$

Discussion Using property data from steam tables and not assuming ideal gas behavior, it can be shown that the Mach number in steam at the specified state is 0.446, which is sufficiently close to the ideal-gas value of 0.441. Therefore, the ideal gas approximation is a reasonable one in this case.



17-24E Problem 2-23E is reconsidered. The variation of Mach number with temperature as the temperature changes between 350° and 700°F is to be investigated, and the results are to be plotted.

Analysis The EES *Equations* window is printed below, along with the tabulated and plotted results.

```
T=Temperature+460
R=0.1102
V=900
k=1.3
c=SQRT(k*R*T*25037)
Ma=V/c
```

Temperature, <i>T</i> , °F	Mach number Ma
350	0.528
375	0.520
400	0.512
425	0.505
450	0.498
475	0.491
500	0.485
525	0.479
550	0.473
575	0.467
600	0.462
625	0.456
650	0.451
675	0.446
700	0.441

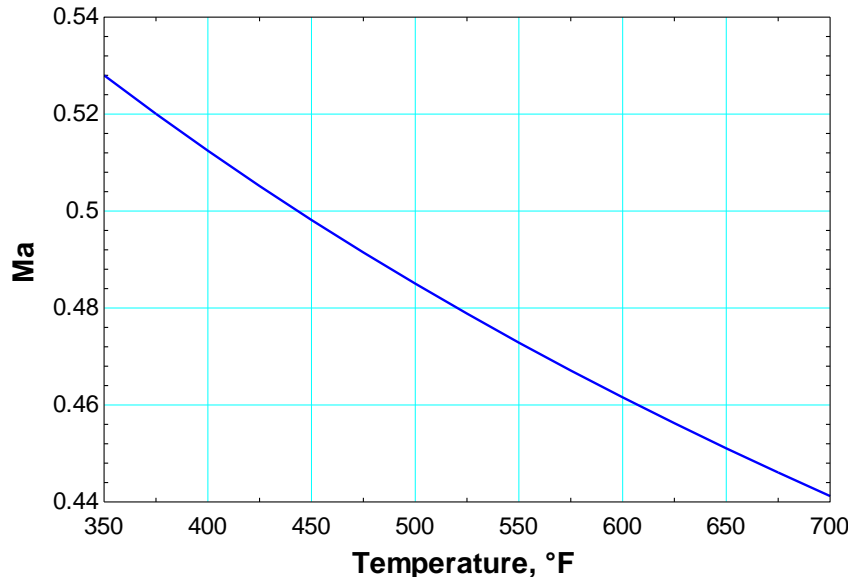

Discussion Note that for a specified flow speed, the Mach number decreases with increasing temperature, as expected.

17-25E The inlet state and the exit pressure of air are given for an isentropic expansion process. The ratio of the initial to the final speed of sound is to be determined.

Assumptions Air is an ideal gas with constant specific heats at room temperature.

Properties The properties of air are $R = 0.06855$ Btu/lbm·R and $k = 1.4$. The specific heat ratio k varies with temperature, but in our case this change is very small and can be disregarded.

Analysis The final temperature of air is determined from the isentropic relation of ideal gases,

$$T_2 = T_1 \left(\frac{P_2}{P_1} \right)^{(k-1)/k} = (659.7 \text{ R}) \left(\frac{60}{170} \right)^{(1.4-1)/1.4} = 489.9 \text{ R}$$

Treating k as a constant, the ratio of the initial to the final speed of sound can be expressed as

$$\text{Ratio} = \frac{c_2}{c_1} = \frac{\sqrt{k_1 R T_1}}{\sqrt{k_2 R T_2}} = \frac{\sqrt{T_1}}{\sqrt{T_2}} = \frac{\sqrt{659.7}}{\sqrt{489.9}} = \mathbf{1.16}$$

Discussion Note that the speed of sound is proportional to the square root of thermodynamic temperature.

17-26 The inlet state and the exit pressure of air are given for an isentropic expansion process. The ratio of the initial to the final speed of sound is to be determined.

Assumptions Air is an ideal gas with constant specific heats at room temperature.

Properties The properties of air are $R = 0.287 \text{ kJ/kg}\cdot\text{K}$ and $k = 1.4$. The specific heat ratio k varies with temperature, but in our case this change is very small and can be disregarded.

Analysis The final temperature of air is determined from the isentropic relation of ideal gases,

$$T_2 = T_1 \left(\frac{P_2}{P_1} \right)^{(k-1)/k} = (350.2 \text{ K}) \left(\frac{0.4 \text{ MPa}}{2.2 \text{ MPa}} \right)^{(1.4-1)/1.4} = 215.2 \text{ K}$$

Treating k as a constant, the ratio of the initial to the final speed of sound can be expressed as

$$\text{Ratio} = \frac{c_2}{c_1} = \frac{\sqrt{k_1 R T_1}}{\sqrt{k_2 R T_2}} = \frac{\sqrt{T_1}}{\sqrt{T_2}} = \frac{\sqrt{350.2}}{\sqrt{215.2}} = \mathbf{1.28}$$

Discussion Note that the speed of sound is proportional to the square root of thermodynamic temperature.

17-27 The inlet state and the exit pressure of helium are given for an isentropic expansion process. The ratio of the initial to the final speed of sound is to be determined.

Assumptions Helium is an ideal gas with constant specific heats at room temperature.

Properties The properties of helium are $R = 2.0769 \text{ kJ/kg}\cdot\text{K}$ and $k = 1.667$.

Analysis The final temperature of helium is determined from the isentropic relation of ideal gases,

$$T_2 = T_1 \left(\frac{P_2}{P_1} \right)^{(k-1)/k} = (350.2 \text{ K}) \left(\frac{0.4}{2.2} \right)^{(1.667-1)/1.667} = 177.0 \text{ K}$$

The ratio of the initial to the final speed of sound can be expressed as

$$\text{Ratio} = \frac{c_2}{c_1} = \frac{\sqrt{k_1 R T_1}}{\sqrt{k_2 R T_2}} = \frac{\sqrt{T_1}}{\sqrt{T_2}} = \frac{\sqrt{350.2}}{\sqrt{177.0}} = \mathbf{1.41}$$

Discussion Note that the speed of sound is proportional to the square root of thermodynamic temperature.

17-28 The expression for the speed of sound for an ideal gas is to be obtained using the isentropic process equation and the definition of the speed of sound.

Analysis The isentropic relation $Pv^k = A$ where A is a constant can also be expressed as

$$P = A \left(\frac{1}{v} \right)^k = A \rho^k$$

Substituting it into the relation for the speed of sound,

$$c^2 = \left(\frac{\partial \mathcal{P}}{\partial \rho} \right)_s = \left(\frac{\partial (A \rho^k)}{\partial \rho} \right)_s = k A \rho^{k-1} = k (A \rho^k) / \rho = k (P / \rho) = k R T$$

since for an ideal gas $P = \rho R T$ or $R T = P / \rho$. Therefore, $c = \sqrt{k R T}$, which is the desired relation.

Discussion Notice that pressure has dropped out; the speed of sound in an ideal gas is *not* a function of pressure.

One Dimensional Isentropic Flow

17-29C We are to determine if it is possible to accelerate a gas to supersonic velocity in a converging nozzle.

Analysis **No**, it is not possible.

Discussion The only way to do it is to have first a converging nozzle, and then a diverging nozzle.

17-30C We are to discuss what happens to several variables when a subsonic gas enters a diverging duct.

Analysis (a) The **velocity decreases**. (b), (c), (d) The **temperature, pressure, and density of the fluid increase**.

Discussion The velocity decrease is opposite to what happens in supersonic flow.

17-31C We are to discuss the pressure at the throats of two different converging-diverging nozzles.

Analysis **The pressures at the two throats are identical.**

Discussion Since the gas has the same stagnation conditions, it also has the same sonic conditions at the throat.

17-32C We are to discuss what happens to several variables when a supersonic gas enters a converging duct.

Analysis (a) The **velocity decreases**. (b), (c), (d) The **temperature, pressure, and density of the fluid increase**.

Discussion The velocity decrease is opposite to what happens in subsonic flow.

17-33C We are to discuss what happens to several variables when a supersonic gas enters a diverging duct.

Analysis (a) The **velocity increases**. (b), (c), (d) The **temperature, pressure, and density of the fluid decrease**.

Discussion The velocity increase is opposite to what happens in subsonic flow.

17-34C We are to discuss what happens to the exit velocity and mass flow rate through a converging nozzle at sonic exit conditions when the nozzle exit area is reduced.

Analysis (a) The **exit velocity remains constant at sonic speed**, (b) the **mass flow rate through the nozzle decreases because of the reduced flow area**.

Discussion Without a diverging portion of the nozzle, a converging nozzle is limited to sonic velocity at the exit.

17-35C We are to discuss what happens to several variables when a subsonic gas enters a converging duct.

Analysis (a) The **velocity increases**. (b), (c), (d) The **temperature, pressure, and density of the fluid decrease**.

Discussion The velocity increase is opposite to what happens in supersonic flow.

17-36 Helium enters a converging-diverging nozzle at specified conditions. The lowest temperature and pressure that can be obtained at the throat of the nozzle are to be determined.

Assumptions **1** Helium is an ideal gas with constant specific heats. **2** Flow through the nozzle is steady, one-dimensional, and isentropic.

Properties The properties of helium are $k = 1.667$ and $c_p = 5.1926 \text{ kJ/kg}\cdot\text{K}$.

Analysis The lowest temperature and pressure that can be obtained at the throat are the critical temperature T^* and critical pressure P^* . First we determine the stagnation temperature T_0 and stagnation pressure P_0 ,

$$T_0 = T + \frac{V^2}{2c_p} = 800 \text{ K} + \frac{(100 \text{ m/s})^2}{2 \times 5.1926 \text{ kJ/kg}\cdot\text{K}} \left(\frac{1 \text{ kJ/kg}}{1000 \text{ m}^2/\text{s}^2} \right) = 801 \text{ K}$$

$$P_0 = P \left(\frac{T_0}{T} \right)^{k/(k-1)} = (0.7 \text{ MPa}) \left(\frac{801 \text{ K}}{800 \text{ K}} \right)^{1.667/(1.667-1)} = 0.702 \text{ MPa}$$

Thus,

$$T^* = T_0 \left(\frac{2}{k+1} \right) = (801 \text{ K}) \left(\frac{2}{1.667+1} \right) = \mathbf{601 \text{ K}}$$

and

$$P^* = P_0 \left(\frac{2}{k+1} \right)^{k/(k-1)} = (0.702 \text{ MPa}) \left(\frac{2}{1.667+1} \right)^{1.667/(1.667-1)} = \mathbf{0.342 \text{ MPa}}$$

Discussion These are the temperature and pressure that will occur at the throat when the flow past the throat is supersonic.

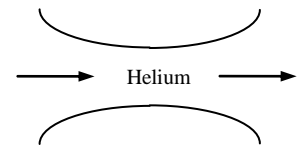

17-37 The speed of an airplane and the air temperature are given. It is to be determined if the speed of this airplane is subsonic or supersonic.

Assumptions Air is an ideal gas with constant specific heats at room temperature.

Properties The gas constant of air is $R = 0.287 \text{ kJ/kg} \cdot \text{K}$. Its specific heat ratio at room temperature is $k = 1.4$.

Analysis The temperature is $-50 + 273.15 = 223.15 \text{ K}$. The speed of sound is

$$c = \sqrt{kRT} = \sqrt{(1.4)(0.287 \text{ kJ/kg} \cdot \text{K})(223.15 \text{ K}) \left(\frac{1000 \text{ m}^2/\text{s}^2}{1 \text{ kJ/kg}} \right) \left(\frac{3.6 \text{ km/h}}{1 \text{ m/s}} \right)} = 1077.97 \text{ km/h}$$

and

$$\text{Ma} = \frac{V}{c} = \frac{1050 \text{ km/h}}{1077.97 \text{ km/h}} = 0.9741 \text{ km/h} \cong \mathbf{0.974}$$

The speed of the airplane is **subsonic** since the Mach number is less than 1.

Discussion Subsonic airplanes stay sufficiently far from the Mach number of 1 to avoid the instabilities associated with transonic flights.

7-38 The critical temperature, pressure, and density of air and helium are to be determined at specified conditions.

Assumptions Air and Helium are ideal gases with constant specific heats at room temperature.

Properties The properties of air at room temperature are $R = 0.287 \text{ kJ/kg}\cdot\text{K}$, $k = 1.4$, and $c_p = 1.005 \text{ kJ/kg}\cdot\text{K}$. The properties of helium at room temperature are $R = 2.0769 \text{ kJ/kg}\cdot\text{K}$, $k = 1.667$, and $c_p = 5.1926 \text{ kJ/kg}\cdot\text{K}$.

Analysis (a) Before we calculate the critical temperature T^* , pressure P^* , and density ρ^* , we need to determine the stagnation temperature T_0 , pressure P_0 , and density ρ_0 .

$$T_0 = 100^\circ\text{C} + \frac{V^2}{2c_p} = 100 + \frac{(250 \text{ m/s})^2}{2 \times 1.005 \text{ kJ/kg}\cdot^\circ\text{C}} \left(\frac{1 \text{ kJ/kg}}{1000 \text{ m}^2/\text{s}^2} \right) = 131.1^\circ\text{C}$$

$$P_0 = P \left(\frac{T_0}{T} \right)^{k/(k-1)} = (200 \text{ kPa}) \left(\frac{404.3 \text{ K}}{373.2 \text{ K}} \right)^{1.4/(1.4-1)} = 264.7 \text{ kPa}$$

$$\rho_0 = \frac{P_0}{RT_0} = \frac{264.7 \text{ kPa}}{(0.287 \text{ kPa}\cdot\text{m}^3/\text{kg}\cdot\text{K})(404.3 \text{ K})} = 2.281 \text{ kg/m}^3$$

Thus,

$$T^* = T_0 \left(\frac{2}{k+1} \right) = (404.3 \text{ K}) \left(\frac{2}{1.4+1} \right) = \mathbf{337 \text{ K}}$$

$$P^* = P_0 \left(\frac{2}{k+1} \right)^{k/(k-1)} = (264.7 \text{ kPa}) \left(\frac{2}{1.4+1} \right)^{1.4/(1.4-1)} = \mathbf{140 \text{ kPa}}$$

$$\rho^* = \rho_0 \left(\frac{2}{k+1} \right)^{1/(k-1)} = (2.281 \text{ kg/m}^3) \left(\frac{2}{1.4+1} \right)^{1/(1.4-1)} = \mathbf{1.45 \text{ kg/m}^3}$$

(b) For helium, $T_0 = T + \frac{V^2}{2c_p} = 40 + \frac{(300 \text{ m/s})^2}{2 \times 5.1926 \text{ kJ/kg}\cdot^\circ\text{C}} \left(\frac{1 \text{ kJ/kg}}{1000 \text{ m}^2/\text{s}^2} \right) = 48.7^\circ\text{C}$

$$P_0 = P \left(\frac{T_0}{T} \right)^{k/(k-1)} = (200 \text{ kPa}) \left(\frac{321.9 \text{ K}}{313.2 \text{ K}} \right)^{1.667/(1.667-1)} = 214.2 \text{ kPa}$$

$$\rho_0 = \frac{P_0}{RT_0} = \frac{214.2 \text{ kPa}}{(2.0769 \text{ kPa}\cdot\text{m}^3/\text{kg}\cdot\text{K})(321.9 \text{ K})} = 0.320 \text{ kg/m}^3$$

Thus,

$$T^* = T_0 \left(\frac{2}{k+1} \right) = (321.9 \text{ K}) \left(\frac{2}{1.667+1} \right) = \mathbf{241 \text{ K}}$$

$$P^* = P_0 \left(\frac{2}{k+1} \right)^{k/(k-1)} = (200 \text{ kPa}) \left(\frac{2}{1.667+1} \right)^{1.667/(1.667-1)} = \mathbf{97.4 \text{ kPa}}$$

$$\rho^* = \rho_0 \left(\frac{2}{k+1} \right)^{1/(k-1)} = (0.320 \text{ kg/m}^3) \left(\frac{2}{1.667+1} \right)^{1/(1.667-1)} = \mathbf{0.208 \text{ kg/m}^3}$$

Discussion These are the temperature, pressure, and density values that will occur at the throat when the flow past the throat is supersonic.

17-39E Air flows through a duct at a specified state and Mach number. The velocity and the stagnation pressure, temperature, and density of the air are to be determined.

Assumptions Air is an ideal gas with constant specific heats at room temperature.

Properties The properties of air are $R = 0.06855 \text{ Btu/lbm}\cdot\text{R} = 0.3704 \text{ psia}\cdot\text{ft}^3/\text{lbm}\cdot\text{R}$ and $k = 1.4$.

Analysis First, $T = 320 + 459.67 = 779.67 \text{ K}$. The speed of sound in air at the specified conditions is

$$c = \sqrt{kRT} = \sqrt{(1.4)(0.06855 \text{ Btu/lbm}\cdot\text{R})(779.67 \text{ R}) \left(\frac{25,037 \text{ ft}^2/\text{s}^2}{1 \text{ Btu/lbm}} \right)} = 1368.72 \text{ ft/s}$$

Thus,

$$V = \text{Ma} \times c = (0.7)(1368.72 \text{ ft/s}) = 958.10 \cong \mathbf{958 \text{ ft/s}}$$

Also,

$$\rho = \frac{P}{RT} = \frac{25 \text{ psia}}{(0.3704 \text{ psia}\cdot\text{ft}^3/\text{lbm}\cdot\text{R})(779.67 \text{ R})} = 0.086568 \text{ lbm/ft}^3$$

Then the stagnation properties are determined from

$$T_0 = T \left(1 + \frac{(k-1)\text{Ma}^2}{2} \right) = (779.67 \text{ R}) \left(1 + \frac{(1.4-1)(0.7)^2}{2} \right) = 856.08 \text{ R} \cong \mathbf{856 \text{ R}}$$

$$P_0 = P \left(\frac{T_0}{T} \right)^{k/(k-1)} = (25 \text{ psia}) \left(\frac{856.08 \text{ R}}{779.67 \text{ R}} \right)^{1.4/(1.4-1)} = 34.678 \text{ psia} \cong \mathbf{34.7 \text{ psia}}$$

$$\rho_0 = \rho \left(\frac{T_0}{T} \right)^{1/(k-1)} = (0.08656 \text{ lbm/ft}^3) \left(\frac{856.08 \text{ R}}{779.67 \text{ R}} \right)^{1/(1.4-1)} = 0.10936 \text{ lbm/ft}^3 \cong \mathbf{0.109 \text{ lbm/ft}^3}$$

Discussion Note that the temperature, pressure, and density of a gas increases during a stagnation process.

17-40 Air enters a converging-diverging nozzle at specified conditions. The lowest pressure that can be obtained at the throat of the nozzle is to be determined.

Assumptions **1** Air is an ideal gas with constant specific heats at room temperature. **2** Flow through the nozzle is steady, one-dimensional, and isentropic.

Properties The specific heat ratio of air at room temperature is $k = 1.4$.

Analysis The lowest pressure that can be obtained at the throat is the critical pressure P^* , which is determined from

$$P^* = P_0 \left(\frac{2}{k+1} \right)^{k/(k-1)} = (1200 \text{ kPa}) \left(\frac{2}{1.4+1} \right)^{1.4/(1.4-1)} = \mathbf{634 \text{ kPa}}$$

Discussion This is the pressure that occurs at the throat when the flow past the throat is supersonic.

17-41 The Mach number of scramjet and the air temperature are given. The speed of the engine is to be determined.

Assumptions Air is an ideal gas with constant specific heats at room temperature.

Properties The gas constant of air is $R = 0.287 \text{ kJ/kg}\cdot\text{K}$. Its specific heat ratio at room temperature is $k = 1.4$.

Analysis The temperature is $-20 + 273.15 = 253.15 \text{ K}$. The speed of sound is

$$c = \sqrt{kRT} = \sqrt{(1.4)(0.287 \text{ kJ/kg}\cdot\text{K})(253.15 \text{ K}) \left(\frac{1000 \text{ m}^2/\text{s}^2}{1 \text{ kJ/kg}} \right)} = 318.93 \text{ m/s}$$

and

$$V = cMa = (318.93 \text{ m/s})(7) \left(\frac{3.6 \text{ km/h}}{1 \text{ m/s}} \right) = 8037 \text{ km/h} \cong \mathbf{8040 \text{ km/h}}$$

Discussion Note that extremely high speed can be achieved with scramjet engines. We cannot justify more than three significant digits in a problem like this.

17-42E The Mach number of scramjet and the air temperature are given. The speed of the engine is to be determined.

Assumptions Air is an ideal gas with constant specific heats at room temperature.

Properties The gas constant of air is $R = 0.06855 \text{ Btu/lbm}\cdot\text{R}$. Its specific heat ratio at room temperature is $k = 1.4$.

Analysis The temperature is $0 + 459.67 = 459.67 \text{ R}$. The speed of sound is

$$c = \sqrt{kRT} = \sqrt{(1.4)(0.06855 \text{ Btu/lbm}\cdot\text{R})(459.67 \text{ R}) \left(\frac{25,037 \text{ ft}^2/\text{s}^2}{1 \text{ Btu/lbm}} \right)} = 1050.95 \text{ ft/s}$$

and

$$V = cMa = (1050.95 \text{ ft/s})(7) \left(\frac{1 \text{ mi/h}}{1.46667 \text{ ft/s}} \right) = 5015.9 \text{ mi/h} \cong \mathbf{5020 \text{ mi/h}}$$

Discussion Note that extremely high speed can be achieved with scramjet engines. We cannot justify more than three significant digits in a problem like this.

17-43 Air flows through a duct. The state of the air and its Mach number are specified. The velocity and the stagnation pressure, temperature, and density of the air are to be determined.

Assumptions Air is an ideal gas with constant specific heats at room temperature.

Properties The properties of air at room temperature are $R = 0.287 \text{ kPa}\cdot\text{m}^3/\text{kg}\cdot\text{K}$ and $k = 1.4$.

Analysis The speed of sound in air at the specified conditions is

$$c = \sqrt{kRT} = \sqrt{(1.4)(0.287 \text{ kJ/kg}\cdot\text{K})(373.2 \text{ K})\left(\frac{1000 \text{ m}^2/\text{s}^2}{1 \text{ kJ/kg}}\right)} = 387.2 \text{ m/s}$$

Thus,

$$V = \text{Ma} \times c = (0.8)(387.2 \text{ m/s}) = \mathbf{310 \text{ m/s}}$$

Also,

$$\rho = \frac{P}{RT} = \frac{200 \text{ kPa}}{(0.287 \text{ kPa}\cdot\text{m}^3/\text{kg}\cdot\text{K})(373.2 \text{ K})} = 1.867 \text{ kg/m}^3$$

Then the stagnation properties are determined from

$$T_0 = T \left(1 + \frac{(k-1)\text{Ma}^2}{2} \right) = (373.2 \text{ K}) \left(1 + \frac{(1.4-1)(0.8)^2}{2} \right) = \mathbf{421 \text{ K}}$$

$$P_0 = P \left(\frac{T_0}{T} \right)^{k/(k-1)} = (200 \text{ kPa}) \left(\frac{421.0 \text{ K}}{373.2 \text{ K}} \right)^{1.4/(1.4-1)} = \mathbf{305 \text{ kPa}}$$

$$\rho_0 = \rho \left(\frac{T_0}{T} \right)^{1/(k-1)} = (1.867 \text{ kg/m}^3) \left(\frac{421.0 \text{ K}}{373.2 \text{ K}} \right)^{1/(1.4-1)} = \mathbf{2.52 \text{ kg/m}^3}$$

Discussion Note that both the pressure and temperature drop as the gas is accelerated as part of the internal energy of the gas is converted to kinetic energy.





17-44 Problem 17-43 is reconsidered. The effect of Mach number on the velocity and stagnation properties as the Ma is varied from 0.1 to 2 are to be investigated, and the results are to be plotted.

Analysis The EES *Equations* window is printed below, along with the tabulated and plotted results.

```
P=200
T=100+273.15
R=0.287
k=1.4
c=SQRT(k*R*T*1000)
Ma=V/c
rho=P/(R*T)
```

"Stagnation properties"

```
T0=T*(1+(k-1)*Ma^2/2)
P0=P*(T0/T)^(k/(k-1))
rho0=rho*(T0/T)^(1/(k-1))
```

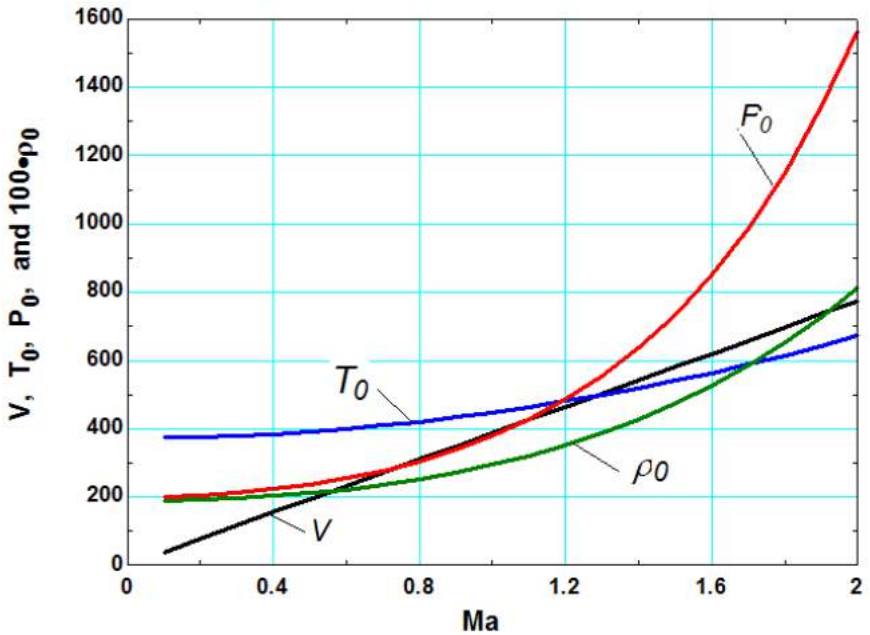

Mach num. Ma	Velocity, V, m/s	Stag. Temp, T_0 , K	Stag. Press, P_0 , kPa	Stag. Density, ρ_0 , kg/m ³
0.1	38.7	373.9	201.4	1.877
0.2	77.4	376.1	205.7	1.905
0.3	116.2	379.9	212.9	1.953
0.4	154.9	385.1	223.3	2.021
0.5	193.6	391.8	237.2	2.110
0.6	232.3	400.0	255.1	2.222
0.7	271.0	409.7	277.4	2.359
0.8	309.8	420.9	304.9	2.524
0.9	348.5	433.6	338.3	2.718
1.0	387.2	447.8	378.6	2.946
1.1	425.9	463.5	427.0	3.210
1.2	464.7	480.6	485.0	3.516
1.3	503.4	499.3	554.1	3.867
1.4	542.1	519.4	636.5	4.269
1.5	580.8	541.1	734.2	4.728
1.6	619.5	564.2	850.1	5.250
1.7	658.3	588.8	987.2	5.842
1.8	697.0	615.0	1149.2	6.511
1.9	735.7	642.6	1340.1	7.267
2.0	774.4	671.7	1564.9	8.118

Discussion Note that as Mach number increases, so does the flow velocity and stagnation temperature, pressure, and density.

17-45 An aircraft is designed to cruise at a given Mach number, elevation, and the atmospheric temperature. The stagnation temperature on the leading edge of the wing is to be determined.

Assumptions Air is an ideal gas with constant specific heats at room temperature.

Properties The properties of air are $R = 0.287 \text{ kPa}\cdot\text{m}^3/\text{kg}\cdot\text{K}$, $c_p = 1.005 \text{ kJ}/\text{kg}\cdot\text{K}$, and $k = 1.4$.

Analysis The speed of sound in air at the specified conditions is

$$c = \sqrt{kRT} = \sqrt{(1.4)(0.287 \text{ kJ}/\text{kg}\cdot\text{K})(236.15 \text{ K})\left(\frac{1000 \text{ m}^2/\text{s}^2}{1 \text{ kJ}/\text{kg}}\right)} = 308.0 \text{ m/s}$$

Thus,

$$V = \text{Ma} \times c = (1.1)(308.0 \text{ m/s}) = 338.8 \text{ m/s}$$

Then,

$$T_0 = T + \frac{V^2}{2c_p} = 236.15 + \frac{(338.8 \text{ m/s})^2}{2 \times 1.005 \text{ kJ}/\text{kg}\cdot\text{K}} \left(\frac{1 \text{ kJ}/\text{kg}}{1000 \text{ m}^2/\text{s}^2}\right) = \mathbf{293 \text{ K}}$$

Discussion Note that the temperature of a gas increases during a stagnation process as the kinetic energy is converted to enthalpy.

17-46 Quiescent carbon dioxide at a given state is accelerated isentropically to a specified Mach number. The temperature and pressure of the carbon dioxide after acceleration are to be determined.

Assumptions Carbon dioxide is an ideal gas with constant specific heats at room temperature.

Properties The specific heat ratio of the carbon dioxide at room temperature is $k = 1.288$.

Analysis The inlet temperature and pressure in this case is equivalent to the stagnation temperature and pressure since the inlet velocity of the carbon dioxide is said to be negligible. That is, $T_0 = T_i = 400 \text{ K}$ and $P_0 = P_i = 1200 \text{ kPa}$. Then,

$$T = T_0 \left(\frac{2}{2 + (k-1)\text{Ma}^2} \right) = (600 \text{ K}) \left(\frac{2}{2 + (1.288-1)(0.6)^2} \right) = 570.43 \text{ K} \cong \mathbf{570 \text{ K}}$$

and

$$P = P_0 \left(\frac{T}{T_0} \right)^{k/(k-1)} = (1200 \text{ kPa}) \left(\frac{570.43 \text{ K}}{600 \text{ K}} \right)^{1.288/(1.288-1)} = 957.23 \text{ K} \cong \mathbf{957 \text{ kPa}}$$

Discussion Note that both the pressure and temperature drop as the gas is accelerated as part of the internal energy of the gas is converted to kinetic energy.

Isentropic Flow Through Nozzles

17-47C We are to analyze if it is possible to accelerate a fluid to supersonic speeds with a velocity that is not sonic at the throat.

Analysis **No, if the flow in the throat is subsonic.** If the velocity at the throat is subsonic, the diverging section would act like a diffuser and decelerate the flow. **Yes, if the flow in the throat is already supersonic,** the diverging section would accelerate the flow to even higher Mach number.

Discussion In duct flow, the latter situation is not possible unless a second converging-diverging portion of the duct is located upstream, and there is sufficient pressure difference to choke the flow in the upstream throat.

17-48C We are to discuss what would happen if we add a diverging section to supersonic flow in a duct.

Analysis The fluid would **accelerate even further**, as desired.

Discussion This is the opposite of what would happen in subsonic flow.

17-49C We are to discuss the difference between Ma^* and Ma .

Analysis Ma^* is the **local velocity non-dimensionalized with respect to the sonic speed at the throat**, whereas Ma is the **local velocity non-dimensionalized with respect to the local sonic speed**.

Discussion The two are identical at the throat when the flow is choked.

17-50C We are to consider subsonic flow through a converging nozzle with critical pressure at the exit, and analyze the effect of lowering back pressure below the critical pressure.

Analysis (a) **No effect on velocity.** (b) **No effect on pressure.** (c) **No effect on mass flow rate.**

Discussion In this situation, the flow is already choked initially, so further lowering of the back pressure does not change anything upstream of the nozzle exit plane.

17-51C We are to compare the mass flow rates through two identical converging nozzles, but with one having a diverging section.

Analysis **If the back pressure is low enough so that sonic conditions exist at the throats, the mass flow rates in the two nozzles would be identical.** However, **if the flow is not sonic at the throat, the mass flow rate through the nozzle with the diverging section would be greater**, because it acts like a subsonic diffuser.

Discussion Once the flow is choked at the throat, whatever happens downstream is irrelevant to the flow upstream of the throat.

17-52C We are to discuss the hypothetical situation of hypersonic flow at the outlet of a converging nozzle.

Analysis Maximum flow rate through a converging nozzle is achieved when $Ma = 1$ at the exit of a nozzle. For all other Ma values the mass flow rate decreases. Therefore, **the mass flow rate would decrease if hypersonic velocities were achieved at the throat of a converging nozzle.**

Discussion Note that this is not possible unless the flow upstream of the converging nozzle is already hypersonic.

17-53C We are to consider subsonic flow through a converging nozzle, and analyze the effect of setting back pressure to critical pressure for a converging nozzle.

Analysis (a) The **exit velocity reaches the sonic speed**, (b) the **exit pressure equals the critical pressure**, and (c) the **mass flow rate reaches the maximum value**.

Discussion In such a case, we say that the flow is *choked*.

17-54C We are to discuss what happens to several variables in the diverging section of a subsonic converging-diverging nozzle.

Analysis (a) The **velocity decreases**, (b) the **pressure increases**, and (c) the **mass flow rate remains the same**.

Discussion Qualitatively, this is the same as what we are used to (in previous chapters) for incompressible flow.

17-55C We are to discuss what would happen if we add a diverging section to supersonic flow in a duct.

Analysis The fluid would **accelerate even further** instead of decelerating.

Discussion This is the opposite of what would happen in subsonic flow.

17-56 Nitrogen enters a converging-diverging nozzle at a given pressure. The critical velocity, pressure, temperature, and density in the nozzle are to be determined.

Assumptions 1 Nitrogen is an ideal gas. 2 Flow through the nozzle is steady, one-dimensional, and isentropic.

Properties The properties of nitrogen are $k = 1.4$ and $R = 0.2968 \text{ kJ/kg}\cdot\text{K}$.

Analysis The stagnation pressure in this case are identical to the inlet properties since the inlet velocity is negligible. They remain constant throughout the nozzle,

$$P_0 = P_i = 700 \text{ kPa}$$

$$T_0 = T_i = 400 \text{ K}$$

$$\rho_0 = \frac{P_0}{RT_0} = \frac{700 \text{ kPa}}{(0.2968 \text{ kPa}\cdot\text{m}^3/\text{kg}\cdot\text{K})(400 \text{ K})} = 5.896 \text{ kg/m}^3$$

Critical properties are those at a location where the Mach number is $\text{Ma} = 1$. From Table A-32 at $\text{Ma} = 1$, we read $T/T_0 = 0.8333$, $P/P_0 = 0.5283$, and $\rho/\rho_0 = 0.6339$. Then the critical properties become

$$T^* = 0.8333T_0 = 0.8333(400 \text{ K}) = \mathbf{333 \text{ K}}$$

$$P^* = 0.5283P_0 = 0.5283(700 \text{ kPa}) = \mathbf{370 \text{ MPa}}$$

$$\rho^* = 0.6339\rho_0 = 0.6339(5.896 \text{ kg/m}^3) = \mathbf{3.74 \text{ kg/m}^3}$$

Also,

$$V^* = c^* = \sqrt{kRT^*} = \sqrt{(1.4)(0.2968 \text{ kJ/kg}\cdot\text{K})(333 \text{ K}) \left(\frac{1000 \text{ m}^2/\text{s}^2}{1 \text{ kJ/kg}} \right)} = \mathbf{372 \text{ m/s}}$$

Discussion We can also solve this problem using the relations for compressible isentropic flow. The results would be identical.

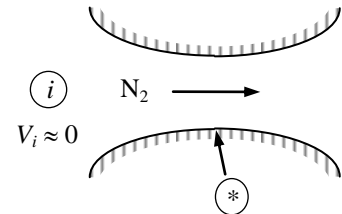

17-57 For an ideal gas, an expression is to be obtained for the ratio of the speed of sound where $\text{Ma} = 1$ to the speed of sound based on the stagnation temperature, c^*/c_0 .

Analysis For an ideal gas the speed of sound is expressed as $c = \sqrt{kRT}$. Thus,

$$\frac{c^*}{c_0} = \frac{\sqrt{kRT^*}}{\sqrt{kRT_0}} = \left(\frac{T^*}{T_0} \right)^{1/2} = \left(\frac{\mathbf{2}}{\mathbf{k+1}} \right)^{1/2}$$

Discussion Note that a speed of sound changes the flow as the temperature changes.

17-58 Air enters a converging-diverging nozzle at a specified pressure. The back pressure that will result in a specified exit Mach number is to be determined.

Assumptions 1 Air is an ideal gas with constant specific heats. 2 Flow through the nozzle is steady, one-dimensional, and isentropic.

Properties The specific heat ratio of air is $k = 1.4$.

Analysis The stagnation pressure in this case is identical to the inlet pressure since the inlet velocity is negligible. It remains constant throughout the nozzle since the flow is isentropic,

$$P_0 = P_i = 1.2 \text{ MPa}$$

From Table A-32 at $\text{Ma}_e = 1.8$, we read $P_e/P_0 = 0.1740$.

Thus,

$$P = 0.1740P_0 = 0.1740(1.2 \text{ MPa}) = \mathbf{0.209 \text{ MPa} = 209 \text{ kPa}}$$

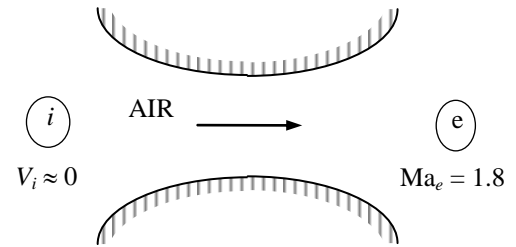

Discussion If we solve this problem using the relations for compressible isentropic flow, the results would be identical.

17-59E Air enters a nozzle at specified temperature, pressure, and velocity. The exit pressure, exit temperature, and exit-to-inlet area ratio are to be determined for a Mach number of $\text{Ma} = 1$ at the exit.

Assumptions 1 Air is an ideal gas with constant specific heats at room temperature. 2 Flow through the nozzle is steady, one-dimensional, and isentropic.

Properties The properties of air are $k = 1.4$ and $c_p = 0.240 \text{ Btu/lbm} \cdot \text{R}$ (Table A-2Ea).

Analysis The properties of the fluid at the location where $\text{Ma} = 1$ are the critical properties, denoted by superscript *. We first determine the stagnation temperature and pressure, which remain constant throughout the nozzle since the flow is isentropic.

$$T_0 = T + \frac{V_i^2}{2c_p} = 630 \text{ R} + \frac{(450 \text{ ft/s})^2}{2 \times 0.240 \text{ Btu/lbm} \cdot \text{R}} \left(\frac{1 \text{ Btu/lbm}}{25,037 \text{ ft}^2/\text{s}^2} \right) = 646.9 \text{ R}$$

$$P_0 = P_i \left(\frac{T_0}{T_i} \right)^{k/(k-1)} = (30 \text{ psia}) \left(\frac{646.9 \text{ K}}{630 \text{ K}} \right)^{1.4/(1.4-1)} = 32.9 \text{ psia}$$

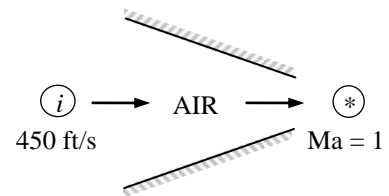

From Table A-32 (or from Eqs. 12-18 and 12-19) at $\text{Ma} = 1$, we read $T/T_0 = 0.8333$, $P/P_0 = 0.5283$. Thus,

$$T = 0.8333T_0 = 0.8333(646.9 \text{ R}) = \mathbf{539 \text{ R}} \quad \text{and} \quad P = 0.5283P_0 = 0.5283(32.9 \text{ psia}) = \mathbf{17.4 \text{ psia}}$$

Also,

$$c_i = \sqrt{kRT_i} = \sqrt{(1.4)(0.06855 \text{ Btu/lbm} \cdot \text{R})(630 \text{ R}) \left(\frac{25,037 \text{ ft}^2/\text{s}^2}{1 \text{ Btu/lbm}} \right)} = 1230 \text{ ft/s} \quad \text{and}$$

$$\text{Ma}_i = \frac{V_i}{c_i} = \frac{450 \text{ ft/s}}{1230 \text{ ft/s}} = 0.3657$$

From Table A-32 at this Mach number we read $A_i/A^* = 1.7426$. Thus the ratio of the throat area to the nozzle inlet area is

$$\frac{A^*}{A_i} = \frac{1}{1.7426} = \mathbf{0.574}$$

Discussion If we solve this problem using the relations for compressible isentropic flow, the results would be identical.

17-60 For subsonic flow at the inlet, the variation of pressure, velocity, and Mach number along the length of the nozzle are to be sketched for an ideal gas under specified conditions.

Assumptions 1 The gas is an ideal gas. 2 Flow through the nozzle is steady, one-dimensional, and isentropic. 3 The flow is choked at the throat.

Analysis Using EES and CO₂ as the gas, we calculate and plot flow area A , velocity V , and Mach number Ma as the pressure drops from a stagnation value of 1400 kPa to 200 kPa. Note that the curve for A is related to the shape of the nozzle, with horizontal axis serving as the centerline. The EES equation window and the plot are shown below.

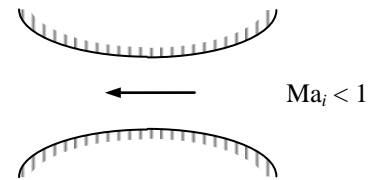

```

k=1.289
Cp=0.846 "kJ/kg.K"
R=0.1889 "kJ/kg.K"
P0=1400 "kPa"

T0=473 "K"
m=3 "kg/s"
rho_0=P0/(R*T0)
rho=P/(R*T)
rho_norm=rho/rho_0 "Normalized density"
T=T0*(P/P0)^((k-1)/k)
Tnorm=T/T0 "Normalized temperature"
V=SQRT(2*Cp*(T0-T)*1000)
V_norm=V/500
A=m/(rho*V)*500
C=SQRT(k*R*T*1000)
Ma=V/C
  
```

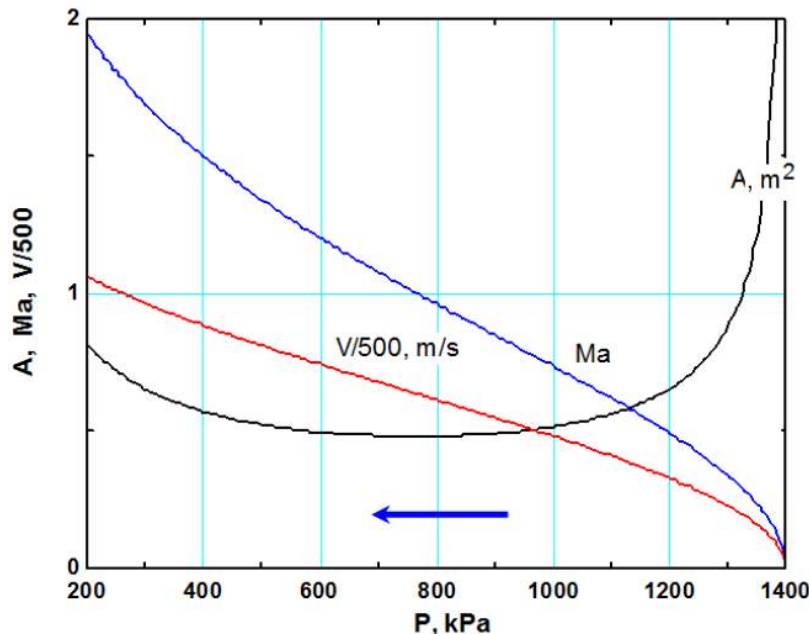

Discussion We are assuming that the back pressure is sufficiently low that the flow is choked at the throat, and the flow downstream of the throat is supersonic without any shock waves. Mach number and velocity continue to rise right through the throat into the diverging portion of the nozzle, since the flow becomes supersonic.

17-61 We repeat the previous problem, but for supersonic flow at the inlet. The variation of pressure, velocity, and Mach number along the length of the nozzle are to be sketched for an ideal gas under specified conditions.

Analysis Using EES and CO₂ as the gas, we calculate and plot flow area A , velocity V , and Mach number Ma as the pressure rises from 200 kPa at a very high velocity to the stagnation value of 1400 kPa. Note that the curve for A is related to the shape of the nozzle, with horizontal axis serving as the centerline.

$k=1.289$
 $C_p=0.846$ "kJ/kg.K"
 $R=0.1889$ "kJ/kg.K"
 $P_0=1400$ "kPa"

$T_0=473$ "K"
 $m=3$ "kg/s"
 $\rho_0=P_0/(R*T_0)$
 $\rho=P/(R*T)$
 $\rho_{norm}=\rho/\rho_0$ "Normalized density"
 $T=T_0*(P/P_0)^{((k-1)/k)}$
 $T_{norm}=T/T_0$ "Normalized temperature"
 $V=\text{SQRT}(2*C_p*(T_0-T)*1000)$
 $V_{norm}=V/500$
 $A=m/(\rho*V)*500$
 $C=\text{SQRT}(k*R*T*1000)$
 $Ma=V/C$

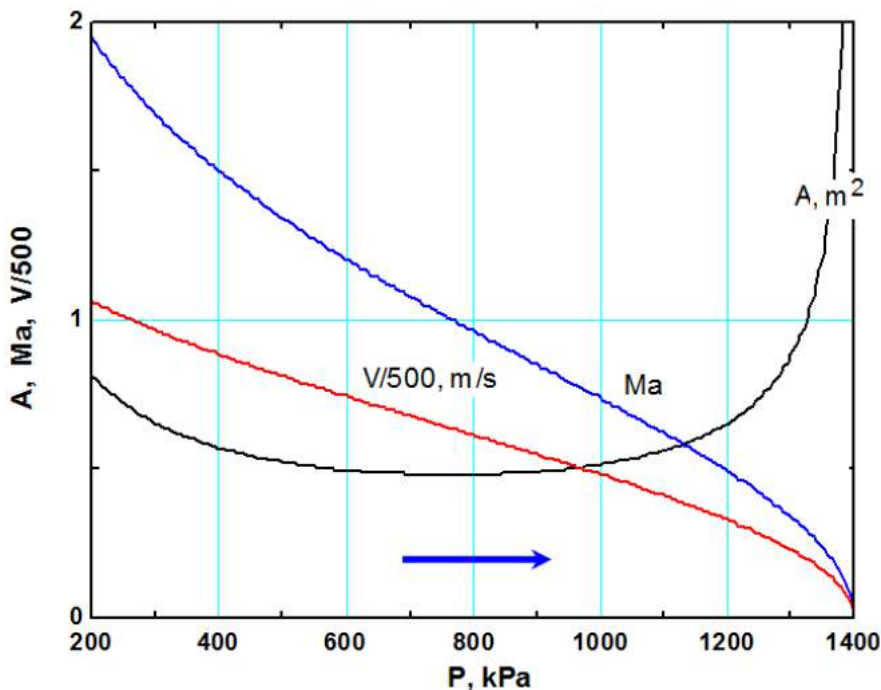
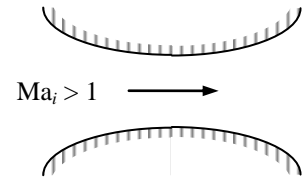

Discussion Note that this problem is identical to the proceeding one, except the flow direction is reversed. In fact, when plotted like this, the plots are identical.

17-62 It is to be explained why the maximum flow rate per unit area for a given ideal gas depends only on $P_0 / \sqrt{T_0}$. Also for an ideal gas, a relation is to be obtained for the constant a in $\dot{m}_{\max} / A^* = a \left(P_0 / \sqrt{T_0} \right)$.

Properties The properties of the ideal gas considered are $R = 0.287 \text{ kPa}\cdot\text{m}^3/\text{kg}\cdot\text{K}$ and $k = 1.4$.

Analysis The maximum flow rate is given by

$$\dot{m}_{\max} = A^* P_0 \sqrt{k/R T_0} \left(\frac{2}{k+1} \right)^{(k+1)/2(k-1)} \quad \text{or} \quad \dot{m}_{\max} / A^* = \left(P_0 / \sqrt{T_0} \right) \sqrt{k/R} \left(\frac{2}{k+1} \right)^{(k+1)/2(k-1)}$$

For a given gas, k and R are fixed, and thus the mass flow rate depends on the parameter $P_0 / \sqrt{T_0}$. Thus, \dot{m}_{\max} / A^* can be expressed as $\dot{m}_{\max} / A^* = a \left(P_0 / \sqrt{T_0} \right)$ where

$$a = \sqrt{k/R} \left(\frac{2}{k+1} \right)^{(k+1)/2(k-1)} = \sqrt{\frac{1.4}{(0.287 \text{ kJ/kg}\cdot\text{K}) \left(\frac{1000 \text{ m}^2/\text{s}^2}{1 \text{ kJ/kg}} \right)}} \left(\frac{2}{1.4+1} \right)^{2.4/0.8} = \mathbf{0.0404 \text{ (m/s)}\sqrt{\text{K}}}$$

Discussion Note that when sonic conditions exist at a throat of known cross-sectional area, the mass flow rate is fixed by the stagnation conditions.

17-63 An ideal gas is flowing through a nozzle. The flow area at a location where $\text{Ma} = 1.8$ is specified. The flow area where $\text{Ma} = 0.9$ is to be determined.

Assumptions Flow through the nozzle is steady, one-dimensional, and isentropic.

Properties The specific heat ratio is given to be $k = 1.4$.

Analysis The flow is assumed to be isentropic, and thus the stagnation and critical properties remain constant throughout the nozzle. The flow area at a location where $\text{Ma}_2 = 0.9$ is determined using A/A^* data from Table A-32 to be

$$\text{Ma}_1 = 1.8: \quad \frac{A_1}{A^*} = 1.4390 \longrightarrow A^* = \frac{A_1}{1.4390} = \frac{36 \text{ cm}^2}{1.4390} = 25.02 \text{ cm}^2$$

$$\text{Ma}_2 = 0.9: \quad \frac{A_2}{A^*} = 1.0089 \longrightarrow A_2 = (1.0089)A^* = (1.0089)(25.02 \text{ cm}^2) = \mathbf{25.2 \text{ cm}^2}$$

Discussion We can also solve this problem using the relations for compressible isentropic flow. The results would be identical.

17-64 An ideal gas is flowing through a nozzle. The flow area at a location where $Ma = 1.8$ is specified. The flow area where $Ma = 0.9$ is to be determined.

Assumptions Flow through the nozzle is steady, one-dimensional, and isentropic.

Analysis The flow is assumed to be isentropic, and thus the stagnation and critical properties remain constant throughout the nozzle. The flow area at a location where $Ma_2 = 0.9$ is determined using the A/A^* relation,

$$\frac{A}{A^*} = \frac{1}{Ma} \left\{ \left(\frac{2}{k+1} \right) \left(1 + \frac{k-1}{2} Ma^2 \right) \right\}^{(k+1)/2(k-1)}$$

For $k = 1.33$ and $Ma_1 = 1.8$:

$$\frac{A_1}{A^*} = \frac{1}{1.8} \left\{ \left(\frac{2}{1.33+1} \right) \left(1 + \frac{1.33-1}{2} 1.8^2 \right) \right\}^{2.33/2 \times 0.33} = 1.4696$$

and,
$$A^* = \frac{A_1}{2.570} = \frac{36 \text{ cm}^2}{1.4696} = 24.50 \text{ cm}^2$$

For $k = 1.33$ and $Ma_2 = 0.9$:

$$\frac{A_2}{A^*} = \frac{1}{0.9} \left\{ \left(\frac{2}{1.33+1} \right) \left(1 + \frac{1.33-1}{2} 0.9^2 \right) \right\}^{2.33/2 \times 0.33} = 1.0091$$

and
$$A_2 = (1.0091)A^* = (1.0091)(24.50 \text{ cm}^2) = \mathbf{24.7 \text{ cm}^2}$$

Discussion Note that the compressible flow functions in Table A-32 are prepared for $k = 1.4$, and thus they cannot be used to solve this problem.

17-65E Air enters a converging-diverging nozzle at a specified temperature and pressure with low velocity. The pressure, temperature, velocity, and mass flow rate are to be calculated in the specified test section.

Assumptions 1 Air is an ideal gas. 2 Flow through the nozzle is steady, one-dimensional, and isentropic.

Properties The properties of air are $k = 1.4$ and $R = 0.06855 \text{ Btu/lbm}\cdot\text{R} = 0.3704 \text{ psia}\cdot\text{ft}^3/\text{lbm}\cdot\text{R}$.

Analysis The stagnation properties in this case are identical to the inlet properties since the inlet velocity is negligible. They remain constant throughout the nozzle since the flow is isentropic.

$$P_0 = P_i = 150 \text{ psia} \quad \text{and} \quad T_0 = T_i = 100^\circ\text{F} \approx 560 \text{ R}$$

Then,

$$T_e = T_0 \left(\frac{2}{2 + (k-1)\text{Ma}^2} \right) = (560 \text{ R}) \left(\frac{2}{2 + (1.4-1)2^2} \right) = \mathbf{311 \text{ R}}$$

$$P_e = P_0 \left(\frac{T}{T_0} \right)^{k/(k-1)} = (150 \text{ psia}) \left(\frac{311}{560} \right)^{1.4/0.4} = \mathbf{19.1 \text{ psia}}$$

$$\rho_e = \frac{P_e}{RT_e} = \frac{19.1 \text{ psia}}{(0.3704 \text{ psia}\cdot\text{ft}^3/\text{lbm}\cdot\text{R})(311 \text{ R})} = 0.1661 \text{ lbm/ft}^3$$

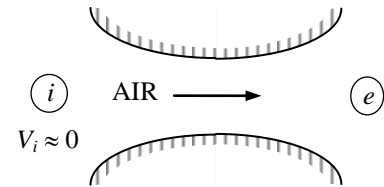

The nozzle exit velocity can be determined from $V_e = \text{Ma}_e c_e$, where c_e is the speed of sound at the exit conditions,

$$V_e = \text{Ma}_e c_e = \text{Ma}_e \sqrt{kRT_e} = (2) \sqrt{(1.4)(0.06855 \text{ Btu/lbm}\cdot\text{R})(311 \text{ R}) \left(\frac{25,037 \text{ ft}^2/\text{s}^2}{1 \text{ Btu/lbm}} \right)} = 1729 \text{ ft/s} \approx \mathbf{1730 \text{ ft/s}}$$

Finally,

$$\dot{m} = \rho_e A_e V_e = (0.1661 \text{ lbm/ft}^3)(5 \text{ ft}^2)(1729 \text{ ft/s}) = 1435 \text{ lbm/s} \approx \mathbf{1440 \text{ lbm/s}}$$

Discussion Air must be very dry in this application because the exit temperature of air is extremely low, and any moisture in the air will turn to ice particles.

17-66 Air enters a nozzle at specified temperature, pressure, and velocity. The exit pressure, exit temperature, and exit-to-inlet area ratio are to be determined for a Mach number of $Ma = 1$ at the exit.

Assumptions **1** Air is an ideal gas with constant specific heats at room temperature. **2** Flow through the nozzle is steady, one-dimensional, and isentropic.

Properties The properties of air are $k = 1.4$ and $c_p = 1.005 \text{ kJ/kg}\cdot\text{K}$.

Analysis The properties of the fluid at the location where $Ma = 1$ are the critical properties, denoted by superscript *. We first determine the stagnation temperature and pressure, which remain constant throughout the nozzle since the flow is isentropic.

$$T_0 = T_i + \frac{V_i^2}{2c_p} = 420 \text{ K} + \frac{(110 \text{ m/s})^2}{2 \times 1.005 \text{ kJ/kg}\cdot\text{K}} \left(\frac{1 \text{ kJ/kg}}{1000 \text{ m}^2/\text{s}^2} \right) = 426.02$$

and

$$P_0 = P \left(\frac{T_0}{T} \right)^{k/(k-1)} = (0.5 \text{ MPa}) \left(\frac{426.02 \text{ K}}{420 \text{ K}} \right)^{1.4/(1.4-1)} = 0.52554 \text{ MPa}$$

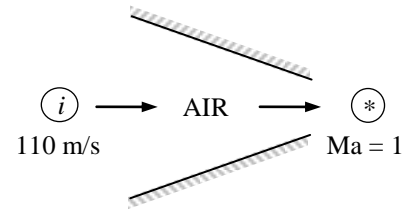

From Table A-32 (or from Eqs. 12-18 and 12-19) at $Ma = 1$, we read $T/T_0 = 0.8333$, $P/P_0 = 0.5283$. Thus,

$$T = 0.8333T_0 = 0.8333(426.02 \text{ K}) = 355.00 \text{ K} \approx \mathbf{355 \text{ K}}$$

and

$$P = 0.5283P_0 = 0.5283(0.52554 \text{ MPa}) = 0.27764 \text{ MPa} \approx \mathbf{0.278 \text{ MPa} = 278 \text{ kPa}}$$

Also,

$$c_i = \sqrt{kRT_i} = \sqrt{(1.4)(0.287 \text{ kJ/kg}\cdot\text{K})(420 \text{ K}) \left(\frac{1000 \text{ m}^2/\text{s}^2}{1 \text{ kJ/kg}} \right)} = 410.799 \text{ m/s}$$

and

$$Ma_i = \frac{V_i}{c_i} = \frac{110 \text{ m/s}}{410.799 \text{ m/s}} = 0.2678$$

$$Ma_i = \frac{V_i}{c_i} = \frac{150 \text{ m/s}}{410.799 \text{ m/s}} = 0.3651$$

From Table A-32 at this Mach number we read $A_i/A^* = 2.3343$. Thus the ratio of the throat area to the nozzle inlet area is

$$\frac{A^*}{A} = \frac{1}{2.3343} = 0.42839 \cong \mathbf{0.428}$$

Discussion We can also solve this problem using the relations for compressible isentropic flow. The results would be identical.

17-67 Air enters a nozzle at specified temperature and pressure with low velocity. The exit pressure, exit temperature, and exit-to-inlet area ratio are to be determined for a Mach number of $Ma = 1$ at the exit.

Assumptions **1** Air is an ideal gas. **2** Flow through the nozzle is steady, one-dimensional, and isentropic.

Properties The specific heat ratio of air is $k = 1.4$.

Analysis The properties of the fluid at the location where $Ma = 1$ are the critical properties, denoted by superscript *. The stagnation temperature and pressure in this case are identical to the inlet temperature and pressure since the inlet velocity is negligible. They remain constant throughout the nozzle since the flow is isentropic.

$$T_0 = T_i = 420 \text{ K} \quad \text{and} \quad P_0 = P_i = 0.5 \text{ MPa}$$

From Table A-32 (or from Eqs. 12-18 and 12-19) at $Ma = 1$, we read $T/T_0 = 0.8333$, $P/P_0 = 0.5283$. Thus,

$$T = 0.8333T_0 = 0.8333(420 \text{ K}) = \mathbf{350 \text{ K}} \quad \text{and} \quad P = 0.5283P_0 = 0.5283(0.5 \text{ MPa}) = \mathbf{0.264 \text{ MPa}}$$

The Mach number at the nozzle inlet is $Ma = 0$ since $V_i \cong 0$. From Table A-32 at this Mach number we read $A_i/A^* = \infty$.

Thus the ratio of the throat area to the nozzle inlet area is $\frac{A^*}{A_i} = \frac{1}{\infty} = \mathbf{0}$.

Discussion If we solve this problem using the relations for compressible isentropic flow, the results would be identical.

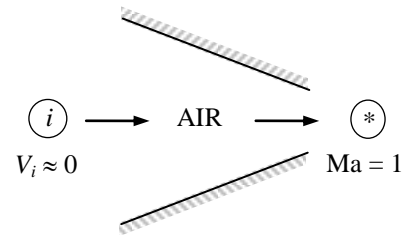



17-68 Air enters a converging nozzle at a specified temperature and pressure with low velocity. The exit pressure, the exit velocity, and the mass flow rate versus the back pressure are to be calculated and plotted.

Assumptions **1** Air is an ideal gas with constant specific heats at room temperature. **2** Flow through the nozzle is steady, one-dimensional, and isentropic.

Properties The properties of air are $k = 1.4$, $R = 0.287 \text{ kJ/kg}\cdot\text{K}$, and $c_p = 1.005 \text{ kJ/kg}\cdot\text{K}$.

Analysis The stagnation properties in this case are identical to the inlet properties since the inlet velocity is negligible. They remain constant throughout the nozzle since the flow is isentropic,

$$P_0 = P_i = 900 \text{ kPa}$$

$$T_0 = T_i = 400 \text{ K}$$

The critical pressure is determined to be

$$P^* = P_0 \left(\frac{2}{k+1} \right)^{k/(k-1)} = (900 \text{ kPa}) \left(\frac{2}{1.4+1} \right)^{1.4/0.4} = 475.5 \text{ kPa}$$

Then the pressure at the exit plane (throat) will be

$$P_e = P_b \quad \text{for} \quad P_b \geq 475.5 \text{ kPa}$$

$$P_e = P^* = 475.5 \text{ kPa} \quad \text{for} \quad P_b < 475.5 \text{ kPa} \quad (\text{choked flow})$$

Thus the back pressure will not affect the flow when $100 < P_b < 475.5 \text{ kPa}$. For a specified exit pressure P_e , the temperature, the velocity and the mass flow rate can be determined from

$$\text{Temperature} \quad T_e = T_0 \left(\frac{P_e}{P_0} \right)^{(k-1)/k} = (400 \text{ K}) \left(\frac{P_e}{900} \right)^{0.4/1.4}$$

$$\text{Velocity} \quad V = \sqrt{2c_p(T_0 - T_e)} = \sqrt{2(1.005 \text{ kJ/kg}\cdot\text{K})(400 - T_e) \left(\frac{1000 \text{ m}^2/\text{s}^2}{1 \text{ kJ/kg}} \right)}$$

$$\text{Density} \quad \rho_e = \frac{P_e}{RT_e} = \frac{P_e}{(0.287 \text{ kPa}\cdot\text{m}^3/\text{kg}\cdot\text{K})T_e}$$

$$\text{Mass flow rate} \quad \dot{m} = \rho_e V_e A_e = \rho_e V_e (0.001 \text{ m}^2)$$

The results of the calculations are tabulated as

P_b , kPa	P_e , kPa	T_e , K	V_e , m/s	ρ_e , kg/m ³	\dot{m} kg/s
900	900	400	0	7.840	0
800	800	386.8	162.9	7.206	1.174
700	700	372.3	236.0	6.551	1.546
600	600	356.2	296.7	5.869	1.741
500	500	338.2	352.4	5.151	1.815
475.5	475.5	333.3	366.2	4.971	1.820
400	475.5	333.3	366.2	4.971	1.820
300	475.5	333.3	366.2	4.971	1.820
200	475.5	333.3	366.2	4.971	1.820
100	475.5	333.3	366.2	4.971	1.820

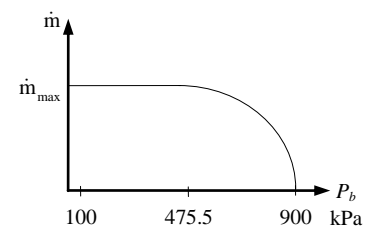
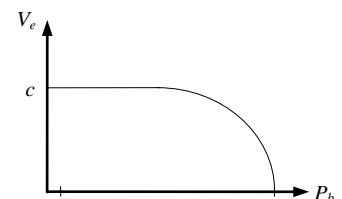
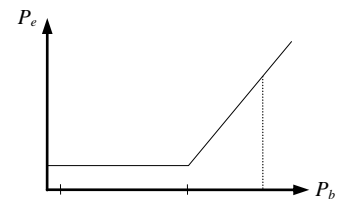
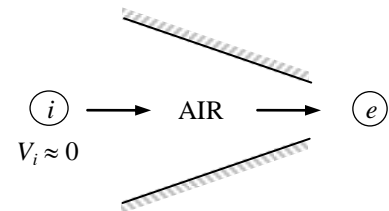

Discussion We see from the plots that once the flow is choked at a back pressure of 475.5 kPa, the mass flow rate remains constant regardless of how low the back pressure gets.



17-69 We are to reconsider the previous problem. Using EES (or other) software, we are to solve the problem for the inlet conditions of 0.8 MPa and 1200 K.

Analysis Air at 800 kPa, 1200 K enters a converging nozzle with a negligible velocity. The throat area of the nozzle is 10 cm². Assuming isentropic flow, calculate and plot the exit pressure, the exit velocity, and the mass flow rate versus the back pressure P_b for $0.8 \geq P_b \geq 0.1$ MPa.

```

Procedure ExitPress(P_back,P_crit : P_exit, Condition$)
If (P_back>=P_crit) then
    P_exit:=P_back           "Unchoked Flow Condition"
    Condition$:= 'unchoked'
else
    P_exit:=P_crit          "Choked Flow Condition"
    Condition$:= 'choked'
Endif
End

Gas$='Air'
A_cm2=10 "Throat area, cm2"
P_inlet =800"kPa"
T_inlet= 1200"K"
"P_back =422.7" "kPa"

A_exit = A_cm2*Convert(cm^2,m^2)
C_p=specheat(Gas$,T=T_inlet)
C_p-C_v=R
k=C_p/C_v
M=MOLARMASS(Gas$)           "Molar mass of Gas$"
R= 8.314/M                  "Gas constant for Gas$"

"Since the inlet velocity is negligible, the stagnation temperature = T_inlet;
and, since the nozzle is isentropic, the stagnation pressure = P_inlet."

P_o=P_inlet                 "Stagnation pressure"
T_o=T_inlet                 "Stagnation temperature"
P_crit /P_o=(2/(k+1))^(k/(k-1)) "Critical pressure from Eq. 16-22"
Call ExitPress(P_back,P_crit : P_exit, Condition$)

T_exit /T_o=(P_exit/P_o)^((k-1)/k) "Exit temperature for isentropic flow, K"

V_exit ^2/2=C_p*(T_o-T_exit)*1000 "Exit velocity, m/s"

Rho_exit=P_exit/(R*T_exit)     "Exit density, kg/m3"

m_dot=Rho_exit*V_exit*A_exit  "Nozzle mass flow rate, kg/s"

"If you wish to redo the plots, hide the diagram window and remove the { } from
the first 4 variables just under the procedure. Next set the desired range of
back pressure in the parametric table. Finally, solve the table (F3). "

```

The table of results and the corresponding plot are provided below.

EES SOLUTION

```

A_cm2=10
A_exit=0.001
Condition$='choked'
C_p=1.208
C_v=0.9211
Gas$='Air'
k=1.312
M=28.97
m_dot=0.9124
P_back=422.7
P_crit=434.9
P_exit=434.9
P_inlet=800
P_o=800
R=0.287
Rho_exit=1.459
T_exit=1038
T_inlet=1200
T_o=1200
V_exit=625.2

```

P_{back} [kPa]	P_{exit} [kPa]	V_{exit} [m/s]	m [kg/s]	T_{exit} K]	ρ_{exit} [kg/m ³]
100	434.9	625.2	0.9124	1038	1.459
200	434.9	625.2	0.9124	1038	1.459
300	434.9	625.2	0.9124	1038	1.459
400	434.9	625.2	0.9124	1038	1.459
422.7	434.9	625.2	0.9124	1038	1.459
500	500	553.5	0.8984	1073	1.623
600	600	437.7	0.8164	1121	1.865
700	700	300.9	0.6313	1163	2.098
800	800	0.001523	0.000003538	1200	2.323

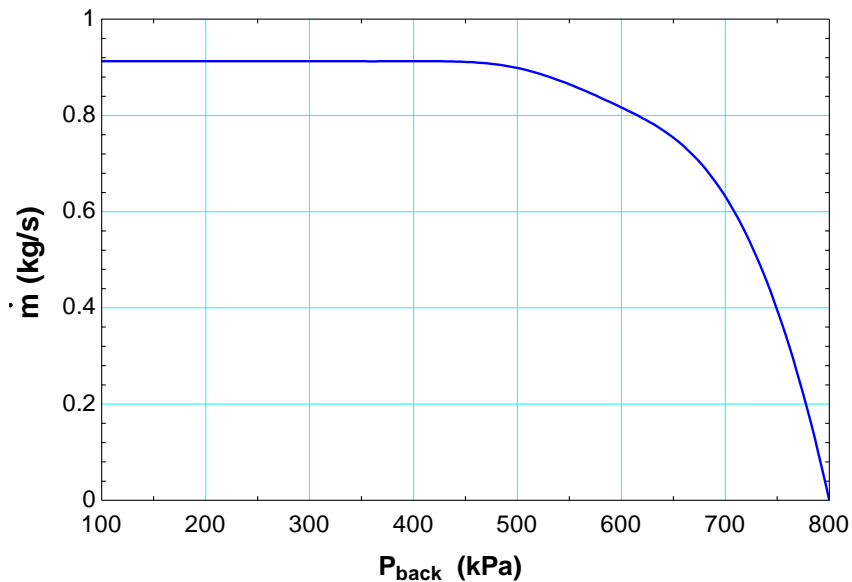

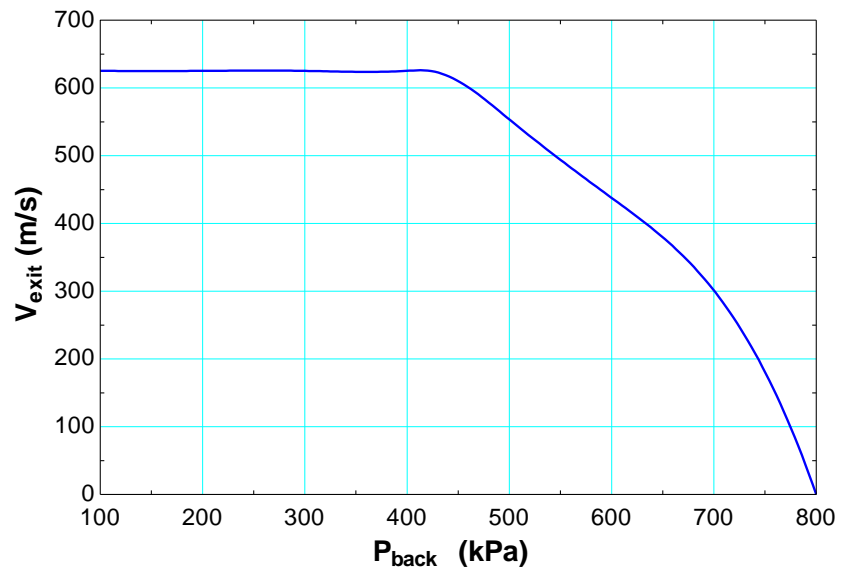
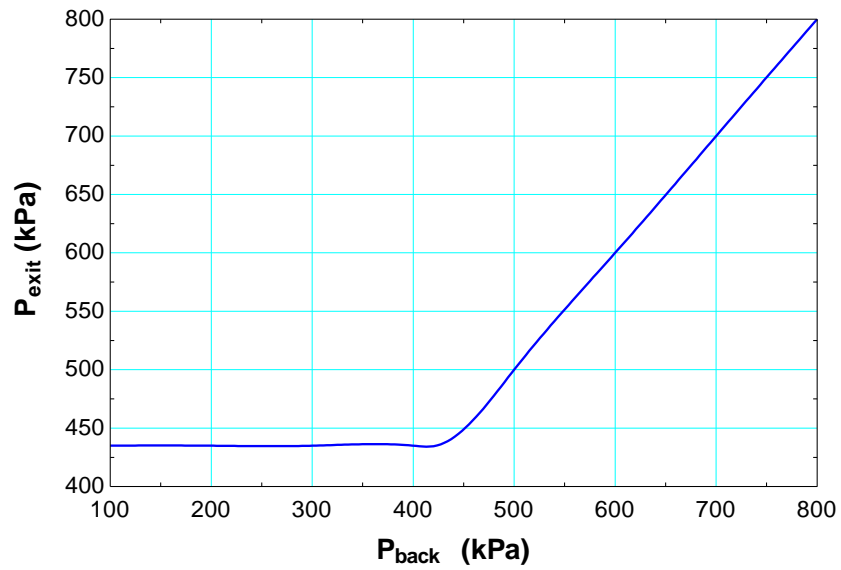

Discussion We see from the plot that once the flow is choked at a back pressure of 422.7 kPa, the mass flow rate remains constant regardless of how low the back pressure gets.

Shock Waves and Expansion Waves

17-70C We are to discuss the applicability of the isentropic flow relations across shocks and expansion waves.

Analysis The isentropic relations of ideal gases are **not applicable for flows across (a) normal shock waves and (b) oblique shock waves**, but they **are applicable for flows across (c) Prandtl-Meyer expansion waves**.

Discussion Flow across any kind of shock wave involves irreversible losses – hence, it cannot be isentropic.

17-71C We are to discuss the states on the Fanno and Rayleigh lines.

Analysis The *Fanno line* represents the **states that satisfy the conservation of mass and energy equations**. The *Rayleigh line* represents the **states that satisfy the conservation of mass and momentum equations**. The *intersections* points of these lines represent the **states that satisfy the conservation of mass, energy, and momentum equations**.

Discussion *T-s* diagrams are quite helpful in understanding these kinds of flows.

17-72C We are to analyze a claim about oblique shock analysis.

Analysis **Yes, the claim is correct.** Conversely, normal shocks can be thought of as special oblique shocks in which the shock angle is $\beta = \pi/2$, or 90° .

Discussion The component of flow in the direction normal to the oblique shock acts exactly like a normal shock. We can think of the flow parallel to the oblique shock as “going along for the ride” – it does not affect anything.

17-73C We are to discuss the effect of a normal shock wave on several properties.

Analysis (a) **velocity decreases**, (b) **static temperature increases**, (c) **stagnation temperature remains the same**, (d) **static pressure increases**, and (e) **stagnation pressure decreases**.

Discussion In addition, the Mach number goes from supersonic ($Ma > 1$) to subsonic ($Ma < 1$).

17-74C We are to discuss the formation of oblique shocks and how they differ from normal shocks.

Analysis *Oblique shocks* occur when **a gas flowing at supersonic speeds strikes a flat or inclined surface**. Normal shock waves are perpendicular to flow whereas inclined shock waves, as the name implies, are typically **inclined relative to the flow direction**. Also, normal shocks form a straight line whereas **oblique shocks can be straight or curved**, depending on the surface geometry.

Discussion In addition, while a normal shock must go from supersonic ($Ma > 1$) to subsonic ($Ma < 1$), the Mach number downstream of an oblique shock can be either supersonic or subsonic.

17-75C We are to discuss whether the flow upstream and downstream of an oblique shock needs to be supersonic.

Analysis **Yes**, the *upstream flow* has to be supersonic for an oblique shock to occur. **No**, the flow *downstream* of an oblique shock can be subsonic, sonic, and even supersonic.

Discussion The latter is not true for normal shocks. For a normal shock, the flow must always go from supersonic ($Ma > 1$) to subsonic ($Ma < 1$).

17-76C We are to determine if Ma downstream of a normal shock can be supersonic.

Analysis **No**, the second law of thermodynamics requires the flow after the shock to be subsonic.

Discussion A normal shock wave always goes from supersonic to subsonic in the flow direction.

17-77C We are to discuss shock detachment at the nose of a 2-D wedge-shaped body.

Analysis **When the wedge half-angle δ is greater than the maximum deflection angle θ_{\max}** , the shock becomes curved and detaches from the nose of the wedge, forming what is called a *detached oblique shock* or a *bow wave*. The numerical value of the shock angle at the nose is $\beta = 90^\circ$.

Discussion When δ is less than θ_{\max} , the oblique shock is attached to the nose.

17-78C We are to discuss the shock at the nose of a rounded body in supersonic flow.

Analysis When supersonic flow impinges on a blunt body like the rounded nose of an aircraft, the wedge half-angle δ at the nose is 90° , and an attached oblique shock cannot exist, regardless of Mach number. Therefore, **a detached oblique shock must occur in front of all such blunt-nosed bodies**, whether two-dimensional, axisymmetric, or fully three-dimensional.

Discussion Since $\delta = 90^\circ$ at the nose, δ is always greater than θ_{\max} , regardless of Ma or the shape of the rest of the body.

17-79C We are to discuss if a shock wave can develop in the converging section of a C-V nozzle.

Analysis **No**, because the flow must be supersonic before a shock wave can occur. The flow in the converging section of a nozzle is always subsonic.

Discussion A normal shock (if it is to occur) would occur in the supersonic (diverging) section of the nozzle.

17-80 Air flowing through a nozzle experiences a normal shock. Various properties are to be calculated before and after the shock.

Assumptions 1 Air is an ideal gas with constant specific heats. 2 Flow through the nozzle is steady, one-dimensional, and isentropic before the shock occurs.

Properties The properties of air at room temperature are $k = 1.4$, $R = 0.287 \text{ kJ/kg}\cdot\text{K}$, and $c_p = 1.005 \text{ kJ/kg}\cdot\text{K}$.

Analysis The stagnation temperature and pressure before the shock are

$$T_{01} = T_1 + \frac{V_1^2}{2c_p} = 230 + \frac{(815 \text{ m/s})^2}{2(1.005 \text{ kJ/kg}\cdot\text{K})} \left(\frac{1 \text{ kJ/kg}}{1000 \text{ m}^2/\text{s}^2} \right) = 560.5 \text{ K}$$

$$P_{01} = P_1 \left(\frac{T_{01}}{T_1} \right)^{k/(k-1)} = (26 \text{ kPa}) \left(\frac{560.5 \text{ K}}{230 \text{ K}} \right)^{1.4/(1.4-1)} = 587.3 \text{ kPa}$$

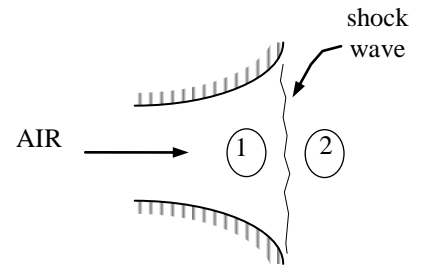

The velocity and the Mach number before the shock are determined from

$$c_1 = \sqrt{kRT_1} = \sqrt{(1.4)(0.287 \text{ kJ/kg}\cdot\text{K})(230 \text{ K})} \left(\frac{1000 \text{ m}^2/\text{s}^2}{1 \text{ kJ/kg}} \right) = \mathbf{304.0 \text{ m/s}}$$

and

$$\text{Ma}_1 = \frac{V_1}{c_1} = \frac{815 \text{ m/s}}{304.0 \text{ m/s}} = \mathbf{2.681}$$

The fluid properties after the shock (denoted by subscript 2) are related to those before the shock through the functions listed in Table A-33. For $\text{Ma}_1 = 2.681$ we read

$$\text{Ma}_2 = \mathbf{0.4972} \quad \frac{P_{02}}{P_1} = 9.7330, \quad \frac{P_2}{P_1} = 8.2208, \quad \text{and} \quad \frac{T_2}{T_1} = 2.3230$$

Then the stagnation pressure P_{02} , static pressure P_2 , and static temperature T_2 , are determined to be

$$P_{02} = 9.7330P_1 = (9.7330)(26 \text{ kPa}) = \mathbf{253.1 \text{ kPa}}$$

$$P_2 = 8.2208P_1 = (8.2208)(26 \text{ kPa}) = \mathbf{213.7 \text{ kPa}}$$

$$T_2 = 2.3230T_1 = (2.3230)(230 \text{ K}) = \mathbf{534.3 \text{ K}}$$

The air velocity after the shock can be determined from $V_2 = \text{Ma}_2 c_2$, where c_2 is the speed of sound at the exit conditions after the shock,

$$V_2 = \text{Ma}_2 c_2 = \text{Ma}_2 \sqrt{kRT_2} = (0.4972) \sqrt{(1.4)(0.287 \text{ kJ/kg}\cdot\text{K})(534.3 \text{ K})} \left(\frac{1000 \text{ m}^2/\text{s}^2}{1 \text{ kJ/kg}} \right) = \mathbf{230.4 \text{ m/s}}$$

Discussion This problem could also be solved using the relations for compressible flow and normal shock functions. The results would be identical.

17-81 Air flowing through a nozzle experiences a normal shock. The entropy change of air across the normal shock wave is to be determined.

Assumptions 1 Air is an ideal gas with constant specific heats. 2 Flow through the nozzle is steady, one-dimensional, and isentropic before the shock occurs.

Properties The properties of air at room temperature are $R = 0.287 \text{ kJ/kg}\cdot\text{K}$ and $c_p = 1.005 \text{ kJ/kg}\cdot\text{K}$.

Analysis The entropy change across the shock is determined to be

$$\begin{aligned} s_2 - s_1 &= c_p \ln \frac{T_2}{T_1} - R \ln \frac{P_2}{P_1} \\ &= (1.005 \text{ kJ/kg}\cdot\text{K}) \ln(2.3230) - (0.287 \text{ kJ/kg}\cdot\text{K}) \ln(8.2208) \\ &= \mathbf{0.242 \text{ kJ/kg}\cdot\text{K}} \end{aligned}$$

Discussion A shock wave is a highly dissipative process, and the entropy generation is large during shock waves.

17-82 For an ideal gas flowing through a normal shock, a relation for V_2/V_1 in terms of k , Ma_1 , and Ma_2 is to be developed.

Analysis The conservation of mass relation across the shock is $\rho_1 V_1 = \rho_2 V_2$ and it can be expressed as

$$\frac{V_2}{V_1} = \frac{\rho_1}{\rho_2} = \frac{P_1 / RT_1}{P_2 / RT_2} = \left(\frac{P_1}{P_2} \right) \left(\frac{T_2}{T_1} \right)$$

From Eqs. 12-35 and 12-38,

$$\frac{V_2}{V_1} = \left(\frac{1 + k\text{Ma}_2^2}{1 + k\text{Ma}_1^2} \right) \left(\frac{1 + \text{Ma}_1^2(k-1)/2}{1 + \text{Ma}_2^2(k-1)/2} \right)$$

Discussion This is an important relation as it enables us to determine the velocity ratio across a normal shock when the Mach numbers before and after the shock are known.

17-83 Air enters a converging-diverging nozzle at a specified state. The required back pressure that produces a normal shock at the exit plane is to be determined for the specified nozzle geometry.

Assumptions 1 Air is an ideal gas. 2 Flow through the nozzle is steady, one-dimensional, and isentropic before the shock occurs. 3 The shock wave occurs at the exit plane.

Analysis The inlet stagnation pressure in this case is identical to the inlet pressure since the inlet velocity is negligible. Since the flow before the shock to be isentropic,

$$P_{01} = P_i = 2 \text{ MPa}$$

It is specified that $A/A^* = 3.5$. From Table A-32, Mach number and the pressure ratio which corresponds to this area ratio are the $Ma_1 = 2.80$ and $P_1/P_{01} = 0.0368$. The pressure ratio across the shock for this Ma_1 value is, from Table A-33, $P_2/P_1 = 8.98$. Thus the back pressure, which is equal to the static pressure at the nozzle exit, must be

$$P_2 = 8.98P_1 = 8.98 \times 0.0368P_{01} = 8.98 \times 0.0368 \times (2 \text{ MPa}) = \mathbf{0.661 \text{ MPa}}$$

Discussion We can also solve this problem using the relations for compressible flow and normal shock functions. The results would be identical.

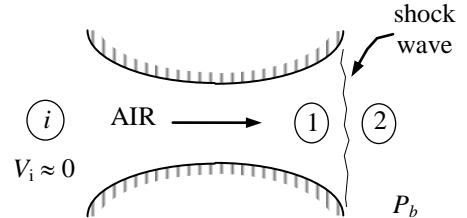

17-84 Air enters a converging-diverging nozzle at a specified state. The required back pressure that produces a normal shock at the exit plane is to be determined for the specified nozzle geometry.

Assumptions 1 Air is an ideal gas. 2 Flow through the nozzle is steady, one-dimensional, and isentropic before the shock occurs.

Analysis The inlet stagnation pressure in this case is identical to the inlet pressure since the inlet velocity is negligible. Since the flow before the shock to be isentropic,

$$P_{0x} = P_i = 2 \text{ MPa}$$

It is specified that $A/A^* = 2$. From Table A-32, the Mach number and the pressure ratio which corresponds to this area ratio are the $Ma_1 = 2.20$ and $P_1/P_{01} = 0.0935$. The pressure ratio across the shock for this M_1 value is, from Table A-33, $P_2/P_1 = 5.48$. Thus the back pressure, which is equal to the static pressure at the nozzle exit, must be

$$P_2 = 5.48P_1 = 5.48 \times 0.0935P_{01} = 5.48 \times 0.0935 \times (2 \text{ MPa}) = \mathbf{1.02 \text{ MPa}}$$

Discussion We can also solve this problem using the relations for compressible flow and normal shock functions. The results would be identical.



17-85E Air flowing through a nozzle experiences a normal shock. Effect of the shock wave on various properties is to be determined. Analysis is to be repeated for helium.

Assumptions **1** Air and helium are ideal gases with constant specific heats. **2** Flow through the nozzle is steady, one-dimensional, and isentropic before the shock occurs.

Properties The properties of air are $k = 1.4$ and $R = 0.06855 \text{ Btu/lbm}\cdot\text{R}$, and the properties of helium are $k = 1.667$ and $R = 0.4961 \text{ Btu/lbm}\cdot\text{R}$.

Analysis The air properties upstream the shock are

$$\text{Ma}_1 = 2.5, P_1 = 10 \text{ psia}, \text{ and } T_1 = 440.5 \text{ R}$$

Fluid properties after the shock (denoted by subscript 2) are related to those before the shock through the functions listed in Table A-33. For $\text{Ma}_1 = 2.5$,

$$\text{Ma}_2 = \mathbf{0.513}, \frac{P_{02}}{P_1} = 8.5262, \frac{P_2}{P_1} = 7.125, \text{ and } \frac{T_2}{T_1} = 2.1375$$

Then the stagnation pressure P_{02} , static pressure P_2 , and static temperature T_2 , are determined to be

$$P_{02} = 8.5262P_1 = (8.5262)(10 \text{ psia}) = \mathbf{85.3 \text{ psia}}$$

$$P_2 = 7.125P_1 = (7.125)(10 \text{ psia}) = \mathbf{71.3 \text{ psia}}$$

$$T_2 = 2.1375T_1 = (2.1375)(440.5 \text{ R}) = \mathbf{942 \text{ R}}$$

The air velocity after the shock can be determined from $V_2 = \text{Ma}_2c_2$, where c_2 is the speed of sound at the exit conditions after the shock,

$$V_2 = \text{Ma}_2c_2 = \text{Ma}_2\sqrt{kRT_2} = (0.513)\sqrt{(1.4)(0.06855 \text{ Btu/lbm}\cdot\text{R})(941.6 \text{ R})\left(\frac{25,037 \text{ ft}^2/\text{s}^2}{1 \text{ Btu/lbm}}\right)} = \mathbf{772 \text{ ft/s}}$$

We now repeat the analysis for helium. This time we cannot use the tabulated values in Table A-33 since k is not 1.4. Therefore, we have to calculate the desired quantities using the analytical relations,

$$\text{Ma}_2 = \left(\frac{\text{Ma}_1^2 + 2/(k-1)}{2\text{Ma}_1^2k/(k-1) - 1}\right)^{1/2} = \left(\frac{2.5^2 + 2/(1.667-1)}{2 \times 2.5^2 \times 1.667/(1.667-1) - 1}\right)^{1/2} = \mathbf{0.553}$$

$$\frac{P_2}{P_1} = \frac{1+k\text{Ma}_1^2}{1+k\text{Ma}_2^2} = \frac{1+1.667 \times 2.5^2}{1+1.667 \times 0.553^2} = 7.5632$$

$$\frac{T_2}{T_1} = \frac{1+\text{Ma}_1^2(k-1)/2}{1+\text{Ma}_2^2(k-1)/2} = \frac{1+2.5^2(1.667-1)/2}{1+0.553^2(1.667-1)/2} = 2.7989$$

$$\begin{aligned} \frac{P_{02}}{P_1} &= \left(\frac{1+k\text{Ma}_1^2}{1+k\text{Ma}_2^2}\right) \left(1+(k-1)\text{Ma}_2^2/2\right)^{k/(k-1)} \\ &= \left(\frac{1+1.667 \times 2.5^2}{1+1.667 \times 0.553^2}\right) \left(1+(1.667-1) \times 0.553^2/2\right)^{1.667/0.667} = 9.641 \end{aligned}$$

Thus, $P_{02} = 11.546P_1 = (11.546)(10 \text{ psia}) = \mathbf{115 \text{ psia}}$

$$P_2 = 7.5632P_1 = (7.5632)(10 \text{ psia}) = \mathbf{75.6 \text{ psia}}$$

$$T_2 = 2.7989T_1 = (2.7989)(440.5 \text{ R}) = \mathbf{1233 \text{ R}}$$

$$V_2 = \text{Ma}_2c_2 = \text{Ma}_2\sqrt{kRT_2} = (0.553)\sqrt{(1.667)(0.4961 \text{ Btu/lbm}\cdot\text{R})(1232.9 \text{ R})\left(\frac{25,037 \text{ ft}^2/\text{s}^2}{1 \text{ Btu/lbm}}\right)} = \mathbf{2794 \text{ ft/s}}$$

Discussion This problem could also be solved using the relations for compressible flow and normal shock functions. The results would be identical.

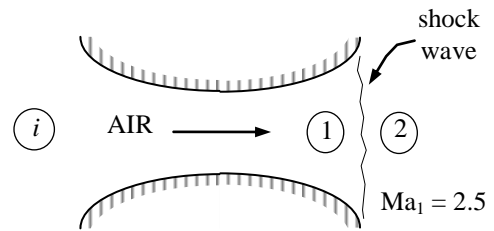



17-86E We are to reconsider Prob. 12-85E. Using EES (or other) software, we are to study the effects of both air and helium flowing steadily in a nozzle when there is a normal shock at a Mach number in the range $2 < M_x < 3.5$. In addition to the required information, we are to calculate the entropy change of the air and helium across the normal shock, and tabulate the results in a parametric table.

Analysis We use EES to calculate the entropy change of the air and helium across the normal shock. The results are given in the Parametric Table for $2 < M_x < 3.5$.

```

Procedure NormalShock(M_x,k:M_y,PyOPx, TyOTx,RhoyORhox, PoyOPox, PoyOPx)
  If M_x < 1 Then
    M_y = -1000;PyOPx=-1000;TyOTx=-1000;RhoyORhox=-1000
    PoyOPox=-1000;PoyOPx=-1000
  else
    M_y=sqrt( (M_x^2+2/(k-1)) / (2*M_x^2*k/(k-1)-1) )
    PyOPx=(1+k*M_x^2)/(1+k*M_y^2)
    TyOTx=( 1+M_x^2*(k-1)/2 )/(1+M_y^2*(k-1)/2 )
    RhoyORhox=PyOPx/TyOTx
    PoyOPox=M_x/M_y*( (1+M_y^2*(k-1)/2)/(1+M_x^2*(k-1)/2) )^((k+1)/(2*(k-1)))
    PoyOPx=(1+k*M_x^2)*(1+M_y^2*(k-1)/2)^(k/(k-1))/(1+k*M_y^2)
  Endif
End

```

```

Function ExitPress(P_back,P_crit)
  If P_back>=P_crit then ExitPress:=P_back "Unchoked Flow Condition"
  If P_back<P_crit then ExitPress:=P_crit "Choked Flow Condition"
End

```

```

Procedure GetProp(Gas$:Cp,k,R) "Cp and k data are from Text Table A.2E"
  M=MOLARMASS(Gas$) "Molar mass of Gas$"
  R= 1545/M "Particular gas constant for Gas$, ft-lbf/lbm-R"
  "k = Ratio of Cp to Cv"
  "Cp = Specific heat at constant pressure"

  if Gas$='Air' then
    Cp=0.24"Btu/lbm-R"; k=1.4
  endif
  if Gas$='CO2' then
    Cp=0.203"Btu/lbm_R"; k=1.289
  endif
  if Gas$='Helium' then
    Cp=1.25"Btu/lbm-R"; k=1.667
  endif
End

```

"Variable Definitions:"

"M = flow Mach Number"

"P_ratio = P/P_o for compressible, isentropic flow"

"T_ratio = T/T_o for compressible, isentropic flow"

"Rho_ratio= Rho/Rho_o for compressible, isentropic flow"

"A_ratio=A/A* for compressible, isentropic flow"

"Fluid properties before the shock are denoted with a subscript x"

"Fluid properties after the shock are denoted with a subscript y"

"M_y = Mach Number down stream of normal shock"

"PyOverPx= P_y/P_x Pressue ratio across normal shock"

"TyOverTx =T_y/T_x Temperature ratio across normal shock"

"RhoyOverRhox=Rho_y/Rho_x Density ratio across normal shock"

"PoyOverPox = P_oy/P_ox Stagation pressure ratio across normal shock"

"PoyOverPx = P_oy/P_x Stagation pressure after normal shock ratioed to pressure before shock"

"Input Data"

```

{P_x = 10 "psia"}           "Values of P_x, T_x, and M_x are set in the Parametric Table"
{T_x = 440.5 "R"}
{M_x = 2.5}
Gas$='Air' "This program has been written for the gases Air, CO2, and Helium"
Call GetProp(Gas$:Cp,k,R)
Call NormalShock(M_x,k:M_y,PyOverPx, TyOverTx,RhoyOverRhox, PoyOverPox, PoyOverPx)
P_oy_air=P_x*PoyOverPx      "Stagnation pressure after the shock"
P_y_air=P_x*PyOverPx        "Pressure after the shock"
T_y_air=T_x*TyOverTx        "Temperature after the shock"
M_y_air=M_y                  "Mach number after the shock"

```

"The velocity after the shock can be found from the product of the Mach number and speed of sound after the shock."

```

C_y_air = sqrt(k*R "ft-lbf/lbm_R"*T_y_air "R"*32.2 "lbf-ft/lbf-s^2")
V_y_air=M_y_air*C_y_air
DELTA_s_air=entropy(air,T=T_y_air, P=P_y_air) -entropy(air,T=T_x,P=P_x)

```

```

Gas2$='Helium' "Gas2$ can be either Helium or CO2"

```

```

Call GetProp(Gas2$:Cp_2,k_2,R_2)
Call NormalShock(M_x,k_2:M_y2,PyOverPx2, TyOverTx2,RhoyOverRhox2, PoyOverPox2, PoyOverPx2)
P_oy_he=P_x*PoyOverPx2      "Stagnation pressure after the shock"
P_y_he=P_x*PyOverPx2        "Pressure after the shock"
T_y_he=T_x*TyOverTx2        "Temperature after the shock"
M_y_he=M_y2                  "Mach number after the shock"

```

"The velocity after the shock can be found from the product of the Mach number and speed of sound after the shock."

```

C_y_he = sqrt(k_2*R_2 "ft-lbf/lbm_R"*T_y_he "R"*32.2 "lbf-ft/lbf-s^2")
V_y_he=M_y_he*C_y_he
DELTA_s_he=entropy(helium,T=T_y_he, P=P_y_he) -entropy(helium,T=T_x,P=P_x)

```

The parametric table and the corresponding plots are shown below.

V _{y,he} [ft/s]	V _{y,air} [ft/s]	T _{y,he} [R]	T _{y,air} [R]	T _x [R]	P _{y,he} [psia]	P _{y,air} [psia]	P _x [psia]	P _{oy,he} [psia]	P _{oy,air} [psia]	M _{y,he}	M _{y,air}	M _x	Δs _{he} [Btu/lbm-R]	Δs _{air} [Btu/lbm-R]
2644	771.9	915.6	743.3	440.5	47.5	45	10	63.46	56.4	0.607	0.5774	2	0.1345	0.0228
2707	767.1	1066	837.6	440.5	60.79	57.4	10	79.01	70.02	0.5759	0.5406	2.25	0.2011	0.0351
2795	771.9	1233	941.6	440.5	75.63	71.25	10	96.41	85.26	0.553	0.513	2.5	0.2728	0.04899
3022	800.4	1616	1180	440.5	110	103.3	10	136.7	120.6	0.5223	0.4752	3	0.4223	0.08
3292	845.4	2066	1460	440.5	150.6	141.3	10	184.5	162.4	0.5032	0.4512	3.5	0.5711	0.1136

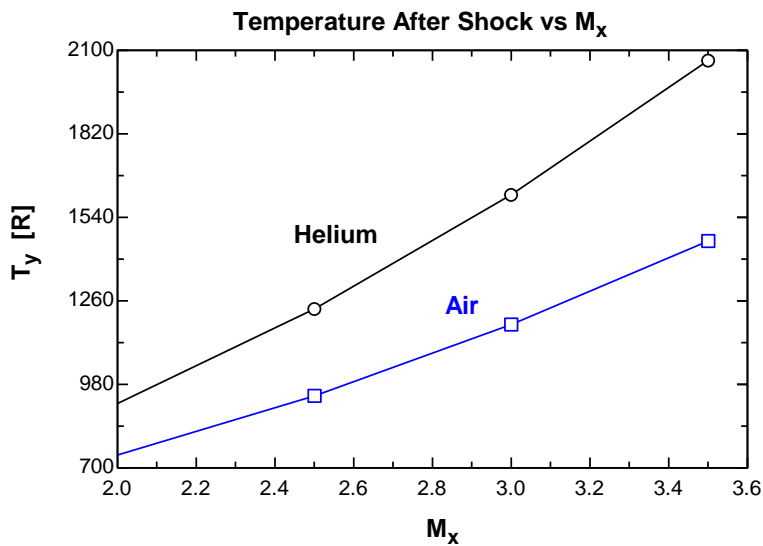
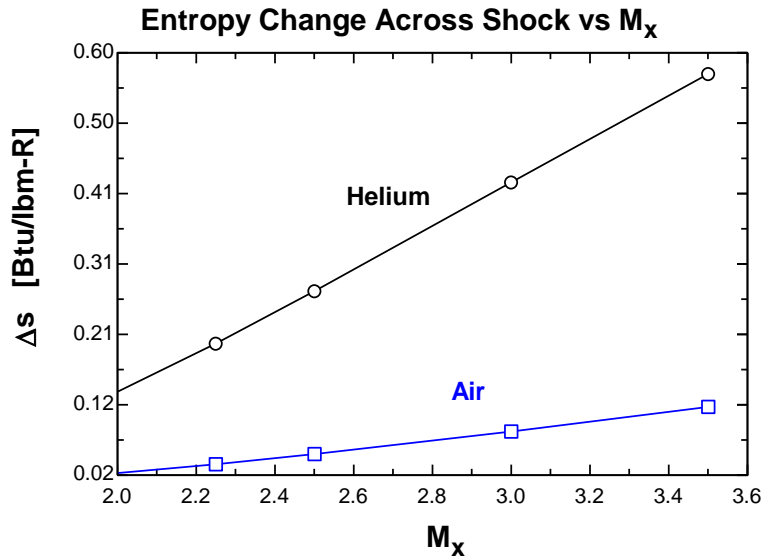
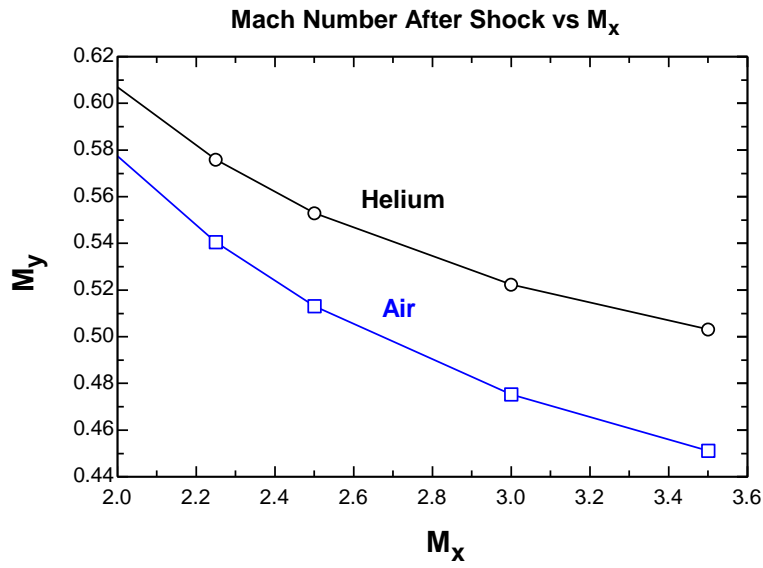

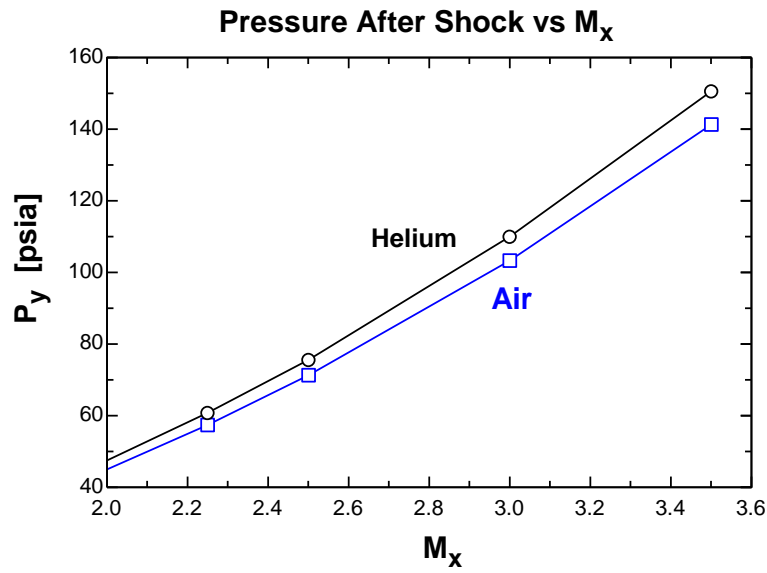
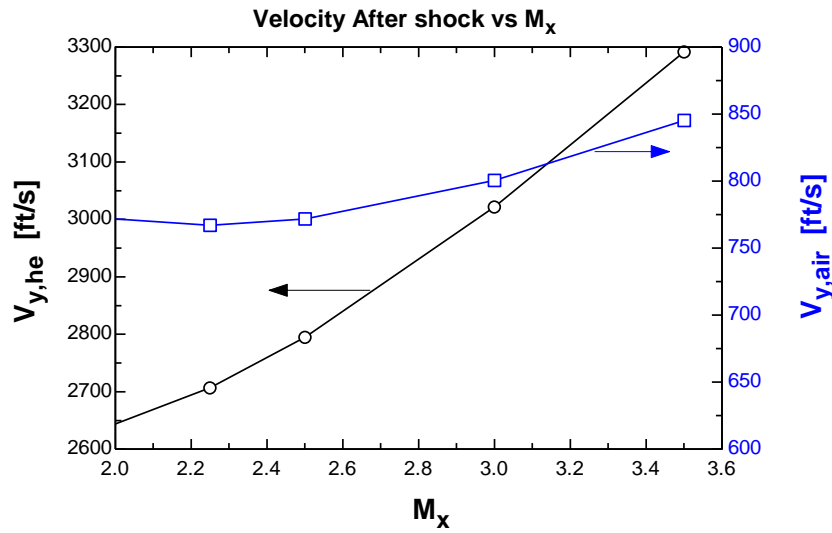

Discussion In all cases, regardless of the fluid or the Mach number, entropy increases across a shock wave. This is because a shock wave involves irreversibilities.

17-87 Air flowing through a converging-diverging nozzle experiences a normal shock at the exit. The effect of the shock wave on various properties is to be determined.

Assumptions **1** Air is an ideal gas with constant specific heats. **2** Flow through the nozzle is steady, one-dimensional, and isentropic before the shock occurs. **3** The shock wave occurs at the exit plane.

Properties The properties of air are $k = 1.4$ and $R = 0.287 \text{ kJ/kg}\cdot\text{K}$.

Analysis The inlet stagnation properties in this case are identical to the inlet properties since the inlet velocity is negligible. Then,

$$P_{01} = P_i = 1 \text{ MPa}$$

$$T_{01} = T_i = 300 \text{ K}$$

Then,

$$T_1 = T_{01} \left(\frac{2}{2 + (k-1)\text{Ma}_1^2} \right) = (300 \text{ K}) \left(\frac{2}{2 + (1.4-1)2.4^2} \right) = 139.4 \text{ K}$$

and

$$P_1 = P_{01} \left(\frac{T_1}{T_0} \right)^{k/(k-1)} = (1 \text{ MPa}) \left(\frac{139.4}{300} \right)^{1.4/0.4} = 0.06840 \text{ MPa}$$

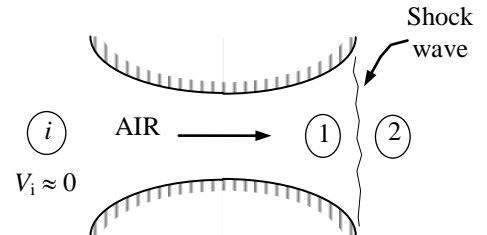

The fluid properties after the shock (denoted by subscript 2) are related to those before the shock through the functions listed in Table A-33. For $\text{Ma}_1 = 2.4$ we read

$$\text{Ma}_2 = 0.5231 \cong \mathbf{0.523}, \quad \frac{P_{02}}{P_{01}} = 0.5401, \quad \frac{P_2}{P_1} = 6.5533, \quad \text{and} \quad \frac{T_2}{T_1} = 2.0403$$

Then the stagnation pressure P_{02} , static pressure P_2 , and static temperature T_2 , are determined to be

$$P_{02} = 0.5401P_{01} = (0.5401)(1.0 \text{ MPa}) = \mathbf{0.540 \text{ MPa} = 540 \text{ kPa}}$$

$$P_2 = 6.5533P_1 = (6.5533)(0.06840 \text{ MPa}) = \mathbf{0.448 \text{ MPa} = 448 \text{ kPa}}$$

$$T_2 = 2.0403T_1 = (2.0403)(139.4 \text{ K}) = \mathbf{284 \text{ K}}$$

The air velocity after the shock can be determined from $V_2 = \text{Ma}_2 c_2$, where c_2 is the speed of sound at the exit conditions after the shock,

$$V_2 = \text{Ma}_2 c_2 = \text{Ma}_2 \sqrt{kRT_2} = (0.5231) \sqrt{(1.4)(0.287 \text{ kJ/kg}\cdot\text{K})(284 \text{ K}) \left(\frac{1000 \text{ m}^2/\text{s}^2}{1 \text{ kJ/kg}} \right)} = \mathbf{177 \text{ m/s}}$$

Discussion We can also solve this problem using the relations for normal shock functions. The results would be identical.



17-88 The entropy change of air across the shock for upstream Mach numbers between 0.5 and 1.5 is to be determined and plotted.

Assumptions 1 Air is an ideal gas. 2 Flow through the nozzle is steady, one-dimensional, and isentropic before the shock occurs.

Properties The properties of air are $k = 1.4$, $R = 0.287$ kJ/kg·K, and $c_p = 1.005$ kJ/kg·K.

Analysis The entropy change across the shock is determined to be

$$s_2 - s_1 = c_p \ln \frac{T_2}{T_1} - R \ln \frac{P_2}{P_1}$$

where

$$\text{Ma}_2 = \left(\frac{\text{Ma}_1^2 + 2/(k-1)}{2\text{Ma}_1^2 k / (k-1) - 1} \right)^{1/2}, \quad \frac{P_2}{P_1} = \frac{1 + k\text{Ma}_1^2}{1 + k\text{Ma}_2^2},$$

and

$$\frac{T_2}{T_1} = \frac{1 + \text{Ma}_1^2(k-1)/2}{1 + \text{Ma}_2^2(k-1)/2}$$

The results of the calculations can be tabulated as

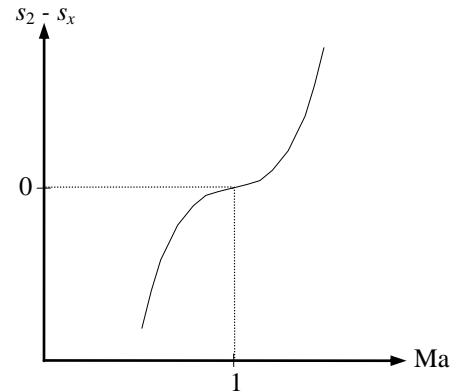

Ma_1	Ma_2	T_2/T_1	P_2/P_1	$s_2 - s_1$
0.5	2.6458	0.1250	0.4375	-1.853
0.6	1.8778	0.2533	0.6287	-1.247
0.7	1.5031	0.4050	0.7563	-0.828
0.8	1.2731	0.5800	0.8519	-0.501
0.9	1.1154	0.7783	0.9305	-0.231
1.0	1.0000	1.0000	1.0000	0.0
1.1	0.9118	1.0649	1.2450	0.0003
1.2	0.8422	1.1280	1.5133	0.0021
1.3	0.7860	1.1909	1.8050	0.0061
1.4	0.7397	1.2547	2.1200	0.0124
1.5	0.7011	1.3202	2.4583	0.0210

Discussion The total entropy change is negative for upstream Mach numbers Ma_1 less than unity. Therefore, normal shocks cannot occur when $\text{Ma}_1 < 1$.

17-89 Supersonic airflow approaches the nose of a two-dimensional wedge and undergoes a straight oblique shock. For a specified Mach number, the minimum shock angle and the maximum deflection angle are to be determined.

Assumptions Air is an ideal gas with a constant specific heat ratio of $k = 1.4$ (so that Fig. 17-43 is applicable).

Analysis For $Ma = 5$, we read from Fig. 12-41

$$\text{Minimum shock (or wave) angle: } \beta_{\min} = 12^\circ$$

$$\text{Maximum deflection (or turning) angle: } \theta_{\max} = 41.5^\circ$$

Discussion Note that the minimum shock angle decreases and the maximum deflection angle increases with increasing Mach number Ma_1 .

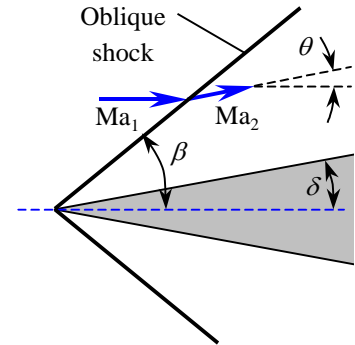

17-90 Air flowing at a specified supersonic Mach number undergoes an expansion turn. The Mach number, pressure, and temperature downstream of the sudden expansion along a wall are to be determined.

Assumptions 1 The flow is steady. 2 The boundary layer on the wedge is very thin. 3 Air is an ideal gas with constant specific heats.

Properties The specific heat ratio of air is $k = 1.4$.

Analysis On the basis of Assumption #2, we take the deflection angle as equal to the wedge half-angle, i.e., $\theta \approx \delta = 15^\circ$. Then the upstream and downstream Prandtl-Meyer functions are determined to be

$$\nu(Ma) = \sqrt{\frac{k+1}{k-1}} \tan^{-1} \left(\sqrt{\frac{k-1}{k+1} (Ma^2 - 1)} \right) - \tan^{-1} \left(\sqrt{Ma^2 - 1} \right)$$

Upstream:

$$\nu(Ma_1) = \sqrt{\frac{1.4+1}{1.4-1}} \tan^{-1} \left(\sqrt{\frac{1.4-1}{1.4+1} (3.6^2 - 1)} \right) - \tan^{-1} \left(\sqrt{3.6^2 - 1} \right) = 60.09^\circ$$

Then the downstream Prandtl-Meyer function becomes

$$\nu(Ma_2) = \theta + \nu(Ma_1) = 15^\circ + 60.09^\circ = 75.09^\circ$$

Ma_2 is found from the Prandtl-Meyer relation, which is now implicit:

$$\text{Downstream: } \nu(Ma_2) = \sqrt{\frac{1.4+1}{1.4-1}} \tan^{-1} \left(\sqrt{\frac{1.4-1}{1.4+1} Ma_2^2 - 1} \right) - \tan^{-1} \left(\sqrt{Ma_2^2 - 1} \right) = 75.09^\circ$$

Solution of this implicit equation gives $Ma_2 = 4.81$. Then the downstream pressure and temperature are determined from the isentropic flow relations:

$$P_2 = \frac{P_2/P_0}{P_1/P_0} P_1 = \frac{[1 + Ma_2^2(k-1)/2]^{-k/(k-1)}}{[1 + Ma_1^2(k-1)/2]^{-k/(k-1)}} P_1 = \frac{[1 + 4.81^2(1.4-1)/2]^{-1.4/0.4}}{[1 + 3.6^2(1.4-1)/2]^{-1.4/0.4}} (32 \text{ kPa}) = \mathbf{6.65 \text{ kPa}}$$

$$T_2 = \frac{T_2/T_0}{T_1/T_0} T_1 = \frac{[1 + Ma_2^2(k-1)/2]^{-1}}{[1 + Ma_1^2(k-1)/2]^{-1}} T_1 = \frac{[1 + 4.81^2(1.4-1)/2]^{-1}}{[1 + 3.6^2(1.4-1)/2]^{-1}} (240 \text{ K}) = \mathbf{153 \text{ K}}$$

Note that this is an expansion, and Mach number increases while pressure and temperature decrease, as expected.

Discussion There are compressible flow calculators on the Internet that solve these implicit equations that arise in the analysis of compressible flow, along with both normal and oblique shock equations; e.g., see www.aoe.vt.edu/~devenpor/aoe3114/calc.html.

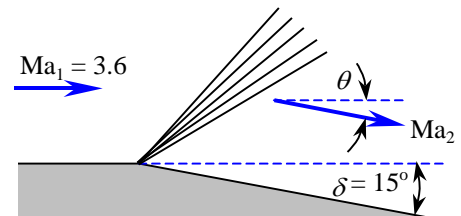

17-91 Air flowing at a specified supersonic Mach number undergoes an expansion turn over a tilted wedge. The Mach number, pressure, and temperature downstream of the sudden expansion above the wedge are to be determined.

Assumptions 1 The flow is steady. 2 The boundary layer on the wedge is very thin. 3 Air is an ideal gas with constant specific heats.

Properties The specific heat ratio of air is $k = 1.4$.

Analysis On the basis of Assumption #2, the deflection angle is determined to be $\theta \approx \delta = 25^\circ - 10^\circ = 15^\circ$. Then the upstream and downstream Prandtl-Meyer functions are determined to be

$$\nu(\text{Ma}) = \sqrt{\frac{k+1}{k-1}} \tan^{-1} \left(\sqrt{\frac{k-1}{k+1} (\text{Ma}^2 - 1)} \right) - \tan^{-1} \left(\sqrt{\text{Ma}^2 - 1} \right)$$

Upstream:

$$\nu(\text{Ma}_1) = \sqrt{\frac{1.4+1}{1.4-1}} \tan^{-1} \left(\sqrt{\frac{1.4-1}{1.4+1} (2.4^2 - 1)} \right) - \tan^{-1} \left(\sqrt{2.4^2 - 1} \right) = 36.75^\circ$$

Then the downstream Prandtl-Meyer function becomes

$$\nu(\text{Ma}_2) = \theta + \nu(\text{Ma}_1) = 15^\circ + 36.75^\circ = 51.75^\circ$$

Now Ma_2 is found from the Prandtl-Meyer relation, which is now implicit:

$$\text{Downstream: } \nu(\text{Ma}_2) = \sqrt{\frac{1.4+1}{1.4-1}} \tan^{-1} \left(\sqrt{\frac{1.4-1}{1.4+1} (\text{Ma}_2^2 - 1)} \right) - \tan^{-1} \left(\sqrt{\text{Ma}_2^2 - 1} \right) = 51.75^\circ$$

It gives $\text{Ma}_2 = \mathbf{3.105}$. Then the downstream pressure and temperature are determined from the isentropic flow relations

$$P_2 = \frac{P_2/P_0}{P_1/P_0} P_1 = \frac{[1 + \text{Ma}_2^2(k-1)/2]^{-k/(k-1)}}{[1 + \text{Ma}_1^2(k-1)/2]^{-k/(k-1)}} P_1 = \frac{[1 + 3.105^2(1.4-1)/2]^{-1.4/0.4}}{[1 + 2.4^2(1.4-1)/2]^{-1.4/0.4}} (70 \text{ kPa}) = \mathbf{23.8 \text{ kPa}}$$

$$T_2 = \frac{T_2/T_0}{T_1/T_0} T_1 = \frac{[1 + \text{Ma}_2^2(k-1)/2]^{-1}}{[1 + \text{Ma}_1^2(k-1)/2]^{-1}} T_1 = \frac{[1 + 3.105^2(1.4-1)/2]^{-1}}{[1 + 2.4^2(1.4-1)/2]^{-1}} (260 \text{ K}) = \mathbf{191 \text{ K}}$$

Note that this is an expansion, and Mach number increases while pressure and temperature decrease, as expected.

Discussion There are compressible flow calculators on the Internet that solve these implicit equations that arise in the analysis of compressible flow, along with both normal and oblique shock equations; e.g., see

www.aoe.vt.edu/~devenpor/aoe3114/calc.html .

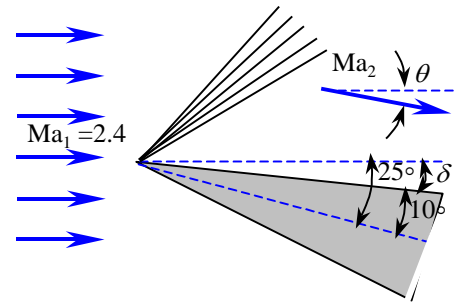

17-92 Air flowing at a specified supersonic Mach number undergoes a compression turn (an oblique shock) over a tilted wedge. The Mach number, pressure, and temperature downstream of the shock below the wedge are to be determined.

Assumptions 1 The flow is steady. 2 The boundary layer on the wedge is very thin. 3 Air is an ideal gas with constant specific heats.

Properties The specific heat ratio of air is $k = 1.4$.

Analysis On the basis of Assumption #2, the deflection angle is determined to be $\theta \approx \delta = 25^\circ + 10^\circ = 35^\circ$. Then the two values of oblique shock angle β are determined from

$$\tan \theta = \frac{2(\text{Ma}_1^2 \sin^2 \beta - 1) / \tan \beta}{\text{Ma}_1^2 (k + \cos 2\beta) + 2} \quad \rightarrow \quad \tan 12^\circ = \frac{2(3.4^2 \sin^2 \beta - 1) / \tan \beta}{3.4^2 (1.4 + \cos 2\beta) + 2}$$

which is implicit in β . Therefore, we solve it by an iterative approach or with an equation solver such as EES. It gives $\beta_{\text{weak}} = 49.86^\circ$ and $\beta_{\text{strong}} = 77.66^\circ$. Then for the case of strong oblique shock, the upstream “normal” Mach number $\text{Ma}_{1,n}$ becomes

$$\text{Ma}_{1,n} = \text{Ma}_1 \sin \beta = 5 \sin 77.66^\circ = 4.884$$

Also, the downstream normal Mach numbers $\text{Ma}_{2,n}$ become

$$\text{Ma}_{2,n} = \sqrt{\frac{(k-1)\text{Ma}_{1,n}^2 + 2}{2k\text{Ma}_{1,n}^2 - k + 1}} = \sqrt{\frac{(1.4-1)(4.884)^2 + 2}{2(1.4)(4.884)^2 - 1.4 + 1}} = 0.4169$$

The downstream pressure and temperature are determined to be

$$P_2 = P_1 \frac{2k\text{Ma}_{1,n}^2 - k + 1}{k + 1} = (70 \text{ kPa}) \frac{2(1.4)(4.884)^2 - 1.4 + 1}{1.4 + 1} = \mathbf{1940 \text{ kPa}}$$

$$T_2 = T_1 \frac{P_2}{P_1} \frac{\rho_1}{\rho_2} = T_1 \frac{P_2}{P_1} \frac{2 + (k-1)\text{Ma}_{1,n}^2}{(k+1)\text{Ma}_{1,n}^2} = (260 \text{ K}) \frac{1940 \text{ kPa}}{70 \text{ kPa}} \frac{2 + (1.4-1)(4.884)^2}{(1.4+1)(4.884)^2} = \mathbf{1450 \text{ K}}$$

The downstream Mach number is determined to be

$$\text{Ma}_2 = \frac{\text{Ma}_{2,n}}{\sin(\beta - \theta)} = \frac{0.4169}{\sin(77.66^\circ - 35^\circ)} = \mathbf{0.615}$$

Discussion Note that $\text{Ma}_{1,n}$ is supersonic and $\text{Ma}_{2,n}$ and Ma_2 are subsonic. Also note the huge rise in temperature and pressure across the strong oblique shock, and the challenges they present for spacecraft during reentering the earth’s atmosphere.

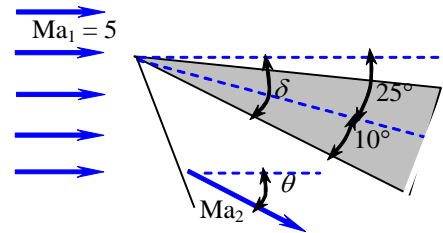

17-93E Air flowing at a specified supersonic Mach number is forced to turn upward by a ramp, and weak oblique shock forms. The wave angle, Mach number, pressure, and temperature after the shock are to be determined.

Assumptions 1 The flow is steady. 2 The boundary layer on the wedge is very thin. 3 Air is an ideal gas with constant specific heats.

Properties The specific heat ratio of air is $k = 1.4$.

Analysis On the basis of Assumption #2, we take the deflection angle as equal to the ramp, i.e., $\theta \approx \delta = 8^\circ$. Then the two values of oblique shock angle β are determined from

$$\tan \theta = \frac{2(\text{Ma}_1^2 \sin^2 \beta - 1) / \tan \beta}{\text{Ma}_1^2 (k + \cos 2\beta) + 2} \quad \rightarrow \quad \tan 8^\circ = \frac{2(2^2 \sin^2 \beta - 1) / \tan \beta}{2^2 (1.4 + \cos 2\beta) + 2}$$

which is implicit in β . Therefore, we solve it by an iterative approach or with an equation solver such as EES. It gives $\beta_{\text{weak}} = 37.21^\circ$ and $\beta_{\text{strong}} = 85.05^\circ$. Then for the case of weak oblique shock, the upstream “normal” Mach number $\text{Ma}_{1,n}$ becomes

$$\text{Ma}_{1,n} = \text{Ma}_1 \sin \beta = 2 \sin 37.21^\circ = 1.209$$

Also, the downstream normal Mach numbers $\text{Ma}_{2,n}$ become

$$\text{Ma}_{2,n} = \sqrt{\frac{(k-1)\text{Ma}_{1,n}^2 + 2}{2k\text{Ma}_{1,n}^2 - k + 1}} = \sqrt{\frac{(1.4-1)(1.209)^2 + 2}{2(1.4)(1.209)^2 - 1.4 + 1}} = 0.8363$$

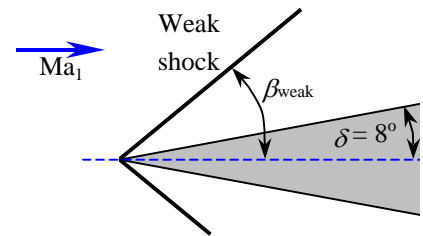

The downstream pressure and temperature are determined to be

$$P_2 = P_1 \frac{2k\text{Ma}_{1,n}^2 - k + 1}{k + 1} = (12 \text{ psia}) \frac{2(1.4)(1.209)^2 - 1.4 + 1}{1.4 + 1} = \mathbf{18.5 \text{ psia}}$$

$$T_2 = T_1 \frac{P_2}{P_1} \frac{\rho_1}{\rho_2} = T_1 \frac{P_2}{P_1} \frac{2 + (k-1)\text{Ma}_{1,n}^2}{(k+1)\text{Ma}_{1,n}^2} = (490 \text{ R}) \frac{18.5 \text{ psia}}{12 \text{ psia}} \frac{2 + (1.4-1)(1.209)^2}{(1.4+1)(1.209)^2} = \mathbf{556 \text{ R}}$$

The downstream Mach number is determined to be

$$\text{Ma}_2 = \frac{\text{Ma}_{2,n}}{\sin(\beta - \theta)} = \frac{0.8363}{\sin(37.21^\circ - 8^\circ)} = \mathbf{1.71}$$

Discussion Note that $\text{Ma}_{1,n}$ is supersonic and $\text{Ma}_{2,n}$ is subsonic. However, Ma_2 is *supersonic* across the weak oblique shock (it is *subsonic* across the strong oblique shock).

17-94E Air flowing at a specified supersonic Mach number is forced to undergo a compression turn (an oblique shock). The Mach number, pressure, and temperature downstream of the oblique shock are to be determined.

Assumptions 1 The flow is steady. 2 The boundary layer on the wedge is very thin. 3 Air is an ideal gas with constant specific heats.

Properties The specific heat ratio of air is $k = 1.4$.

Analysis On the basis of Assumption #2, we take the deflection angle as equal to the wedge half-angle, i.e., $\theta \approx \delta = 15^\circ$. Then the two values of oblique shock angle β are determined from

$$\tan \theta = \frac{2(\text{Ma}_1^2 \sin^2 \beta - 1) / \tan \beta}{\text{Ma}_1^2 (k + \cos 2\beta) + 2} \rightarrow \tan 15^\circ = \frac{2(2^2 \sin^2 \beta - 1) / \tan \beta}{2^2 (1.4 + \cos 2\beta) + 2}$$

which is implicit in β . Therefore, we solve it by an iterative approach or with an equation solver such as EES. It gives $\beta_{\text{weak}} = 45.34^\circ$ and $\beta_{\text{strong}} = 79.83^\circ$. Then the upstream “normal” Mach number $\text{Ma}_{1,n}$ becomes

$$\text{Weak shock: } \text{Ma}_{1,n} = \text{Ma}_1 \sin \beta = 2 \sin 45.34^\circ = 1.423$$

$$\text{Strong shock: } \text{Ma}_{1,n} = \text{Ma}_1 \sin \beta = 2 \sin 79.83^\circ = 1.969$$

Also, the downstream normal Mach numbers $\text{Ma}_{2,n}$ become

$$\text{Weak shock: } \text{Ma}_{2,n} = \sqrt{\frac{(k-1)\text{Ma}_{1,n}^2 + 2}{2k\text{Ma}_{1,n}^2 - k + 1}} = \sqrt{\frac{(1.4-1)(1.423)^2 + 2}{2(1.4)(1.423)^2 - 1.4 + 1}} = 0.7304$$

$$\text{Strong shock: } \text{Ma}_{2,n} = \sqrt{\frac{(k-1)\text{Ma}_{1,n}^2 + 2}{2k\text{Ma}_{1,n}^2 - k + 1}} = \sqrt{\frac{(1.4-1)(1.969)^2 + 2}{2(1.4)(1.969)^2 - 1.4 + 1}} = 0.5828$$

The downstream pressure and temperature for each case are determined to be

$$\text{Weak shock: } P_2 = P_1 \frac{2k\text{Ma}_{1,n}^2 - k + 1}{k + 1} = (6 \text{ psia}) \frac{2(1.4)(1.423)^2 - 1.4 + 1}{1.4 + 1} = 17.57 \cong \mathbf{17.6 \text{ psia}}$$

$$T_2 = T_1 \frac{P_2}{P_1} \frac{\rho_1}{\rho_2} = T_1 \frac{P_2}{P_1} \frac{2 + (k-1)\text{Ma}_{1,n}^2}{(k+1)\text{Ma}_{1,n}^2} = (480 \text{ R}) \frac{17.57 \text{ psia}}{6 \text{ psia}} \frac{2 + (1.4-1)(1.423)^2}{(1.4+1)(1.423)^2} = 609.5 \text{ R} \cong \mathbf{610 \text{ R}}$$

$$\text{Strong shock: } P_2 = P_1 \frac{2k\text{Ma}_{1,n}^2 - k + 1}{k + 1} = (8 \text{ psia}) \frac{2(1.4)(1.969)^2 - 1.4 + 1}{1.4 + 1} = 34.85 \cong \mathbf{34.9 \text{ psia}}$$

$$T_2 = T_1 \frac{P_2}{P_1} \frac{\rho_1}{\rho_2} = T_1 \frac{P_2}{P_1} \frac{2 + (k-1)\text{Ma}_{1,n}^2}{(k+1)\text{Ma}_{1,n}^2} = (480 \text{ R}) \frac{34.85 \text{ psia}}{8 \text{ psia}} \frac{2 + (1.4-1)(1.969)^2}{(1.4+1)(1.969)^2} = 797.9 \text{ R} \cong \mathbf{798 \text{ R}}$$

The downstream Mach number is determined to be

$$\text{Weak shock: } \text{Ma}_2 = \frac{\text{Ma}_{2,n}}{\sin(\beta - \theta)} = \frac{0.7304}{\sin(45.34^\circ - 15^\circ)} = \mathbf{1.45}$$

$$\text{Strong shock: } \text{Ma}_2 = \frac{\text{Ma}_{2,n}}{\sin(\beta - \theta)} = \frac{0.5828}{\sin(79.83^\circ - 15^\circ)} = \mathbf{0.644}$$

Discussion Note that the change in Mach number, pressure, temperature across the *strong shock* are much greater than the changes across the *weak shock*, as expected. For both the weak and strong oblique shock cases, $\text{Ma}_{1,n}$ is supersonic and $\text{Ma}_{2,n}$ is subsonic. However, Ma_2 is *supersonic* across the weak oblique shock, but *subsonic* across the strong oblique shock.

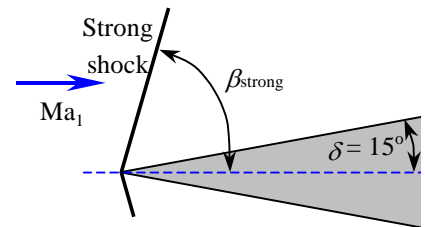
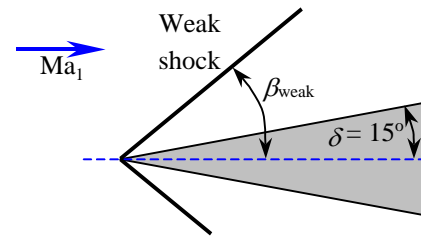

17-95 Air flowing at a specified supersonic Mach number impinges on a two-dimensional wedge. The shock angle, Mach number, and pressure downstream of the weak and strong oblique shock formed by a wedge are to be determined.

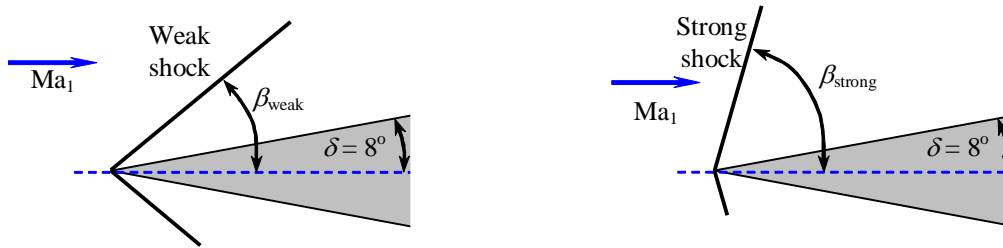

Assumptions 1 The flow is steady. 2 The boundary layer on the wedge is very thin. 3 Air is an ideal gas with constant specific heats.

Properties The specific heat ratio of air is $k = 1.4$.

Analysis On the basis of Assumption #2, we take the deflection angle as equal to the wedge half-angle, i.e., $\theta \approx \delta = 8^\circ$. Then the two values of oblique shock angle β are determined from

$$\tan \theta = \frac{2(\text{Ma}_1^2 \sin^2 \beta - 1) / \tan \beta}{\text{Ma}_1^2 (k + \cos 2\beta) + 2} \rightarrow \tan 8^\circ = \frac{2(3.4^2 \sin^2 \beta - 1) / \tan \beta}{3.4^2 (1.4 + \cos 2\beta) + 2}$$

which is implicit in β . Therefore, we solve it by an iterative approach or with an equation solver such as EES. It gives $\beta_{\text{weak}} = 23.15^\circ$ and $\beta_{\text{strong}} = 87.45^\circ$. Then the upstream “normal” Mach number $\text{Ma}_{1,n}$ becomes

$$\text{Weak shock: } \text{Ma}_{1,n} = \text{Ma}_1 \sin \beta = 3.4 \sin 23.15^\circ = 1.336$$

$$\text{Strong shock: } \text{Ma}_{1,n} = \text{Ma}_1 \sin \beta = 3.4 \sin 87.45^\circ = 3.397$$

Also, the downstream normal Mach numbers $\text{Ma}_{2,n}$ become

$$\text{Weak shock: } \text{Ma}_{2,n} = \sqrt{\frac{(k-1)\text{Ma}_{1,n}^2 + 2}{2k\text{Ma}_{1,n}^2 - k + 1}} = \sqrt{\frac{(1.4-1)(1.336)^2 + 2}{2(1.4)(1.336)^2 - 1.4 + 1}} = 0.7681$$

$$\text{Strong shock: } \text{Ma}_{2,n} = \sqrt{\frac{(k-1)\text{Ma}_{1,n}^2 + 2}{2k\text{Ma}_{1,n}^2 - k + 1}} = \sqrt{\frac{(1.4-1)(3.397)^2 + 2}{2(1.4)(3.397)^2 - 1.4 + 1}} = 0.4553$$

The downstream pressure for each case is determined to be

$$\text{Weak shock: } P_2 = P_1 \frac{2k\text{Ma}_{1,n}^2 - k + 1}{k + 1} = (60 \text{ kPa}) \frac{2(1.4)(1.336)^2 - 1.4 + 1}{1.4 + 1} = \mathbf{115.0 \text{ kPa}}$$

$$\text{Strong shock: } P_2 = P_1 \frac{2k\text{Ma}_{1,n}^2 - k + 1}{k + 1} = (60 \text{ kPa}) \frac{2(1.4)(3.397)^2 - 1.4 + 1}{1.4 + 1} = \mathbf{797.6 \text{ kPa}}$$

The downstream Mach number is determined to be

$$\text{Weak shock: } \text{Ma}_2 = \frac{\text{Ma}_{2,n}}{\sin(\beta - \theta)} = \frac{0.7681}{\sin(23.15^\circ - 8^\circ)} = \mathbf{2.94}$$

$$\text{Strong shock: } \text{Ma}_2 = \frac{\text{Ma}_{2,n}}{\sin(\beta - \theta)} = \frac{0.4553}{\sin(87.45^\circ - 8^\circ)} = \mathbf{0.463}$$

Discussion Note that the change in Mach number and pressure across the *strong shock* are much greater than the changes across the *weak shock*, as expected. For both the weak and strong oblique shock cases, $\text{Ma}_{1,n}$ is supersonic and $\text{Ma}_{2,n}$ is subsonic. However, Ma_2 is *supersonic* across the weak oblique shock, but *subsonic* across the strong oblique shock.

17-96 Air flowing through a nozzle experiences a normal shock. The effect of the shock wave on various properties is to be determined. Analysis is to be repeated for helium under the same conditions.

Assumptions 1 Air and helium are ideal gases with constant specific heats. 2 Flow through the nozzle is steady, one-dimensional, and isentropic before the shock occurs.

Properties The properties of air are $k = 1.4$ and $R = 0.287 \text{ kJ/kg}\cdot\text{K}$, and the properties of helium are $k = 1.667$ and $R = 2.0769 \text{ kJ/kg}\cdot\text{K}$.

Analysis The air properties upstream the shock are

$$\text{Ma}_1 = 2.6, P_1 = 58 \text{ kPa}, \text{ and } T_1 = 270 \text{ K}$$

Fluid properties after the shock (denoted by subscript 2) are related to those before the shock through the functions in Table A-33. For $\text{Ma}_1 = 2.6$,

$$\text{Ma}_2 = \mathbf{0.5039}, \frac{P_{02}}{P_1} = 9.1813, \frac{P_2}{P_1} = 7.7200, \text{ and } \frac{T_2}{T_1} = 2.2383$$

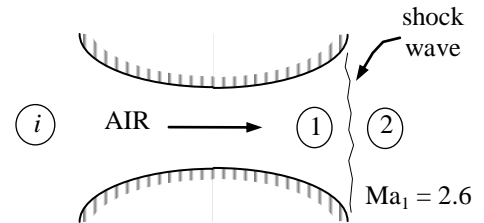

We obtained these values using analytical relations in Table 14. Then the stagnation pressure P_{02} , static pressure P_2 , and static temperature T_2 , are determined to be

$$P_{02} = 9.1813P_1 = (9.1813)(58 \text{ kPa}) = \mathbf{532.5 \text{ kPa}}$$

$$P_2 = 7.7200P_1 = (7.7200)(58 \text{ kPa}) = \mathbf{447.8 \text{ kPa}}$$

$$T_2 = 2.2383T_1 = (2.2383)(270 \text{ K}) = \mathbf{604.3 \text{ K}}$$

The air velocity after the shock can be determined from $V_2 = \text{Ma}_2 c_2$, where c_2 is the speed of sound at the exit conditions after the shock,

$$V_2 = \text{Ma}_2 c_2 = \text{Ma}_2 \sqrt{kRT_2} = (0.5039) \sqrt{(1.4)(0.287 \text{ kJ/kg}\cdot\text{K})(604.3 \text{ K}) \left(\frac{1000 \text{ m}^2/\text{s}^2}{1 \text{ kJ/kg}} \right)} = \mathbf{248.3 \text{ m/s}}$$

We now repeat the analysis for helium. This time we cannot use the tabulated values in Table A-33 since k is not 1.4. Therefore, we have to calculate the desired quantities using the analytical relations,

$$\text{Ma}_2 = \left(\frac{\text{Ma}_1^2 + 2/(k-1)}{2\text{Ma}_1^2 k/(k-1) - 1} \right)^{1/2} = \left(\frac{2.6^2 + 2/(1.667-1)}{2 \times 2.6^2 \times 1.667/(1.667-1) - 1} \right)^{1/2} = \mathbf{0.5455}$$

$$\frac{P_2}{P_1} = \frac{1 + k\text{Ma}_1^2}{1 + k\text{Ma}_2^2} = \frac{1 + 1.667 \times 2.6^2}{1 + 1.667 \times 0.5455^2} = 8.2009$$

$$\frac{T_2}{T_1} = \frac{1 + \text{Ma}_1^2(k-1)/2}{1 + \text{Ma}_2^2(k-1)/2} = \frac{1 + 2.6^2(1.667-1)/2}{1 + 0.5455^2(1.667-1)/2} = 2.9606$$

$$\begin{aligned} \frac{P_{02}}{P_1} &= \left(\frac{1 + k\text{Ma}_1^2}{1 + k\text{Ma}_2^2} \right) \left(1 + (k-1)\text{Ma}_2^2/2 \right)^{k/(k-1)} \\ &= \left(\frac{1 + 1.667 \times 2.6^2}{1 + 1.667 \times 0.5455^2} \right) \left(1 + (1.667-1) \times 0.5455^2/2 \right)^{1.667/0.667} = 10.389 \end{aligned}$$

Thus, $P_{02} = 10.389P_1 = (10.389)(58 \text{ kPa}) = \mathbf{602.5 \text{ kPa}}$

$$P_2 = 8.2009P_1 = (8.2009)(58 \text{ kPa}) = \mathbf{475.7 \text{ kPa}}$$

$$T_2 = 2.9606T_1 = (2.9606)(270 \text{ K}) = \mathbf{799.4 \text{ K}}$$

$$V_2 = \text{Ma}_2 c_2 = \text{Ma}_2 \sqrt{kRT_2} = (0.5455) \sqrt{(1.667)(2.0769 \text{ kJ/kg}\cdot\text{K})(799.4 \text{ K}) \left(\frac{1000 \text{ m}^2/\text{s}^2}{1 \text{ kJ/kg}} \right)} = \mathbf{907.5 \text{ m/s}}$$

Discussion The velocity and Mach number are higher for helium than for air due to the different values of k and R .

17-97 Air flowing through a nozzle experiences a normal shock. The entropy change of air across the normal shock wave is to be determined.

Assumptions 1 Air and helium are ideal gases with constant specific heats. 2 Flow through the nozzle is steady, one-dimensional, and isentropic before the shock occurs.

Properties The properties of air are $R = 0.287 \text{ kJ/kg}\cdot\text{K}$ and $c_p = 1.005 \text{ kJ/kg}\cdot\text{K}$, and the properties of helium are $R = 2.0769 \text{ kJ/kg}\cdot\text{K}$ and $c_p = 5.1926 \text{ kJ/kg}\cdot\text{K}$.

Analysis For air, the entropy change across the shock is determined to be

$$s_2 - s_1 = c_p \ln \frac{T_2}{T_1} - R \ln \frac{P_2}{P_1} = (1.005 \text{ kJ/kg}\cdot\text{K}) \ln(2.2383) - (0.287 \text{ kJ/kg}\cdot\text{K}) \ln(7.7200) = \mathbf{0.223 \text{ kJ/kg}\cdot\text{K}}$$

For helium, the entropy change across the shock is determined to be

$$s_2 - s_1 = c_p \ln \frac{T_2}{T_1} - R \ln \frac{P_2}{P_1} = (5.1926 \text{ kJ/kg}\cdot\text{K}) \ln(2.9606) - (2.0769 \text{ kJ/kg}\cdot\text{K}) \ln(8.2009) = \mathbf{1.27 \text{ kJ/kg}\cdot\text{K}}$$

Discussion Note that shock wave is a highly dissipative process, and the entropy generation is large during shock waves.

Duct Flow with Heat Transfer and Negligible Friction (Rayleigh Flow)

17-98C We are to discuss the effect of heating on the flow velocity in subsonic Rayleigh flow.

Analysis Heating the fluid **increases the flow velocity in subsonic Rayleigh flow, but decreases the flow velocity in supersonic Rayleigh flow.**

Discussion These results are not necessarily intuitive, but must be true in order to satisfy the conservation laws.

17-99C We are to discuss what the points on a T - s diagram of Rayleigh flow represent.

Analysis The points on the Rayleigh line represent the **states that satisfy the conservation of mass, momentum, and energy equations as well as the property relations for a given state.** Therefore, for a given inlet state, the fluid cannot exist at any downstream state outside the Rayleigh line on a T - s diagram.

Discussion The T - s diagram is quite useful, since any downstream state must lie on the Rayleigh line.

17-100C We are to discuss the effect of heat gain and heat loss on entropy during Rayleigh flow.

Analysis In Rayleigh flow, **the effect of heat gain is to increase the entropy of the fluid, and the effect of heat loss is to decrease the entropy.**

Discussion You should recall from thermodynamics that the entropy of a system can be lowered by removing heat.

17-101C We are to discuss how temperature and stagnation temperature change in subsonic Rayleigh flow.

Analysis In Rayleigh flow, the **stagnation temperature T_0 always increases with heat transfer to the fluid**, but the temperature T decreases with heat transfer in the Mach number range of $0.845 < Ma < 1$ for air. Therefore, the **temperature in this case will decrease**.

Discussion This at first seems counterintuitive, but if heat were *not* added, the temperature would drop even *more* if the air were accelerated isentropically from $Ma = 0.92$ to 0.95 .

17-102C We are to discuss the characteristic aspect of Rayleigh flow, and its main assumptions.

Analysis The characteristic aspect of Rayleigh flow is **its involvement of heat transfer**. The main assumptions associated with Rayleigh flow are: the flow is **steady, one-dimensional**, and **frictionless** through a constant-area duct, and the fluid is an **ideal gas with constant specific heats**.

Discussion Of course, there is no such thing as frictionless flow. It is better to say that frictional effects are negligible compared to the heating effects.

17-103C We are to examine the Mach number at the end of a choked duct in Rayleigh flow when more heat is added.

Analysis The flow is choked, and thus the flow at the duct exit **remains sonic**.

Discussion There is no mechanism for the flow to become supersonic in this case.

17-104 Argon flowing at subsonic velocity in a constant-diameter duct is accelerated by heating. The highest rate of heat transfer without reducing the mass flow rate is to be determined.

Assumptions 1 The assumptions associated with Rayleigh flow (i.e., steady one-dimensional flow of an ideal gas with constant properties through a constant cross-sectional area duct with negligible frictional effects) are valid. 2 Mass flow rate remains constant.

Properties We take the properties of argon to be $k = 1.667$, $c_p = 0.5203 \text{ kJ/kg}\cdot\text{K}$, and $R = 0.2081 \text{ kJ/kg}\cdot\text{K}$.

Analysis Heat transfer stops when the flow is choked, and thus $\text{Ma}_2 = V_2/c_2 = 1$. The inlet stagnation temperature is

$$T_{01} = T_1 \left(1 + \frac{k-1}{2} \text{Ma}_1^2 \right) = (400 \text{ K}) \left(1 + \frac{1.667-1}{2} 0.2^2 \right) = 405.3 \text{ K}$$

The Rayleigh flow functions corresponding to the inlet and exit Mach numbers are

$$T_{02}/T_0^* = 1 \quad (\text{since } \text{Ma}_2 = 1)$$

$$\frac{T_{01}}{T_0^*} = \frac{(k+1)\text{Ma}_1^2 [2 + (k-1)\text{Ma}_1^2]}{(1+k\text{Ma}_1^2)^2} = \frac{(1.667+1)0.2^2 [2 + (1.667-1)0.2^2]}{(1+1.667 \times 0.2^2)^2} = 0.1900$$

Therefore,

$$\frac{T_{02}}{T_{01}} = \frac{T_{02}/T_0^*}{T_{01}/T_0^*} = \frac{1}{0.1900} \quad \rightarrow \quad T_{02} = T_{01} / 0.1900 = (405.3 \text{ K}) / 0.1900 = 2133 \text{ K}$$

Then the rate of heat transfer becomes

$$\dot{Q} = \dot{m}_{\text{air}} c_p (T_{02} - T_{01}) = (1.2 \text{ kg/s})(0.5203 \text{ kJ/kg}\cdot\text{K})(2133 - 400) \text{ K} = \mathbf{1080 \text{ kW}}$$

Discussion It can also be shown that $T_2 = 1600 \text{ K}$, which is the highest thermodynamic temperature that can be attained under stated conditions. If more heat is transferred, the additional temperature rise will cause the mass flow rate to decrease. Also, in the solution of this problem, we cannot use the values of Table A-34 since they are based on $k = 1.4$.

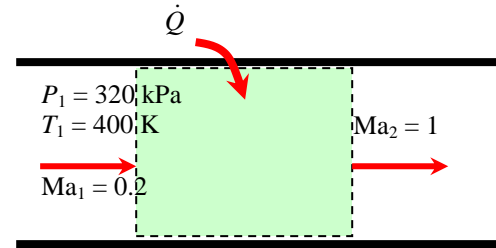

17-105 Air is heated in a duct during subsonic flow until it is choked. For specified pressure and velocity at the exit, the temperature, pressure, and velocity at the inlet are to be determined.

Assumptions The assumptions associated with Rayleigh flow (i.e., steady one-dimensional flow of an ideal gas with constant properties through a constant cross-sectional area duct with negligible frictional effects) are valid.

Properties We take the properties of air to be $k = 1.4$, $c_p = 1.005 \text{ kJ/kg}\cdot\text{K}$, and $R = 0.287 \text{ kJ/kg}\cdot\text{K}$.

Analysis Noting that sonic conditions exist at the exit, the exit temperature is

$$c_2 = V_2/\text{Ma}_2 = (680 \text{ m/s})/1 = 680 \text{ m/s}$$

$$c_2 = \sqrt{kRT_2} \rightarrow \sqrt{(1.4)(0.287 \text{ kJ/kg}\cdot\text{K})T_2 \left(\frac{1000 \text{ m}^2/\text{s}^2}{1 \text{ kJ/kg}} \right)} = 680 \text{ m/s}$$

It gives

$$T_2 = 1151 \text{ K.}$$

Then the exit stagnation temperature becomes

$$T_{02} = T_2 + \frac{V_2^2}{2c_p} = 1151 \text{ K} + \frac{(680 \text{ m/s})^2}{2 \times 1.005 \text{ kJ/kg}\cdot\text{K}} \left(\frac{1 \text{ kJ/kg}}{1000 \text{ m}^2/\text{s}^2} \right) = 1381 \text{ K}$$

The inlet stagnation temperature is, from the energy equation $q = c_p(T_{02} - T_{01})$,

$$T_{01} = T_{02} - \frac{q}{c_p} = 1381 \text{ K} - \frac{67 \text{ kJ/kg}}{1.005 \text{ kJ/kg}\cdot\text{K}} = 1314 \text{ K}$$

The maximum value of stagnation temperature T_0^* occurs at $\text{Ma} = 1$, and its value in this case is T_{02} since the flow is choked. Therefore, $T_0^* = T_{02} = 1381 \text{ K}$. Then the stagnation temperature ratio at the inlet, and the Mach number corresponding to it are, from Table A-34,

$$\frac{T_{01}}{T_0^*} = \frac{1314 \text{ K}}{1381 \text{ K}} = 0.9516 \rightarrow \text{Ma}_1 = 0.7779 \cong \mathbf{0.778}$$

The Rayleigh flow functions corresponding to the inlet and exit Mach numbers are (Table A-34):

$$\begin{array}{llll} \text{Ma}_1 = 0.7779: & T_1/T^* = 1.018, & P_1/P^* = 1.301, & V_1/V^* = 0.7852 \\ \text{Ma}_2 = 1: & T_2/T^* = 1, & P_2/P^* = 1, & V_2/V^* = 1 \end{array}$$

Then the inlet temperature, pressure, and velocity are determined to be

$$\frac{T_2}{T_1} = \frac{T_2/T^*}{T_1/T^*} = \frac{1}{1.018} \rightarrow T_1 = 1.018T_2 = 1.018(1151 \text{ K}) = \mathbf{1172 \text{ K}}$$

$$\frac{P_2}{P_1} = \frac{P_2/P^*}{P_1/P^*} = \frac{1}{1.301} \rightarrow P_1 = 1.301P_2 = 1.301(270 \text{ kPa}) = \mathbf{351.3 \text{ kPa}}$$

$$\frac{V_2}{V_1} = \frac{V_2/V^*}{V_1/V^*} = \frac{1}{0.7852} \rightarrow V_1 = 0.7852V_2 = 0.7852(680 \text{ m/s}) = \mathbf{533.9 \text{ m/s}}$$

Discussion Note that the temperature and pressure decreases with heating during this subsonic Rayleigh flow while velocity increases. This problem can also be solved using appropriate relations instead of tabulated values, which can likewise be coded for convenient computer solutions.

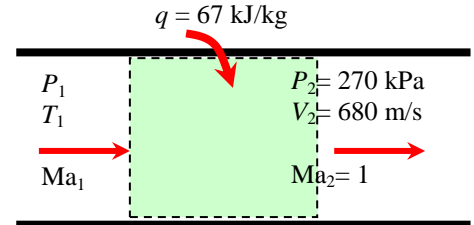

17-106 Air enters the combustion chamber of a gas turbine at a subsonic velocity. For a specified rate of heat transfer, the Mach number at the exit and the loss in stagnation pressure to be determined.

Assumptions 1 The assumptions associated with Rayleigh flow (i.e., steady one-dimensional flow of an ideal gas with constant properties through a constant cross-sectional area duct with negligible frictional effects) are valid. 2 The cross-sectional area of the combustion chamber is constant. 3 The increase in mass flow rate due to fuel injection is disregarded.

Properties We take the properties of air to be $k = 1.4$, $c_p = 1.005$ kJ/kg·K, and $R = 0.287$ kJ/kg·K.

Analysis The inlet stagnation temperature and pressure are

$$T_{01} = T_1 \left(1 + \frac{k-1}{2} \text{Ma}_1^2 \right) = (700 \text{ K}) \left(1 + \frac{1.4-1}{2} 0.2^2 \right) = 705.6 \text{ K}$$

$$P_{01} = P_1 \left(1 + \frac{k-1}{2} \text{Ma}_1^2 \right)^{k/(k-1)} = (600 \text{ kPa}) \left(1 + \frac{1.4-1}{2} 0.2^2 \right)^{1.4/0.4} = 617.0 \text{ kPa}$$

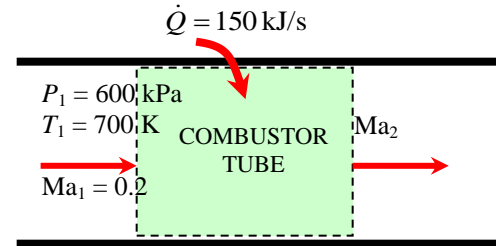

The exit stagnation temperature is determined from

$$\dot{Q} = \dot{m}_{\text{air}} c_p (T_{02} - T_{01}) \rightarrow 150 \text{ kJ/s} = (0.3 \text{ kg/s})(1.005 \text{ kJ/kg} \cdot \text{K})(T_{02} - 705.6 \text{ K})$$

It gives

$$T_{02} = 1203 \text{ K}$$

At $\text{Ma}_1 = 0.2$ we read from $T_{01}/T_0^* = 0.1736$ (Table A-34). Therefore,

$$T_0^* = \frac{T_{01}}{0.1736} = \frac{705.6 \text{ K}}{0.1736} = 4064.5 \text{ K}$$

Then the stagnation temperature ratio at the exit and the Mach number corresponding to it are (Table A-34)

$$\frac{T_{02}}{T_0^*} = \frac{1203 \text{ K}}{4064.5 \text{ K}} = 0.2960 \rightarrow \text{Ma}_2 = 0.2706 \cong \mathbf{0.271}$$

Also,

$$\text{Ma}_1 = 0.2 \rightarrow P_{01}/P_0^* = 1.2346$$

$$\text{Ma}_2 = 0.2706 \rightarrow P_{02}/P_0^* = 1.2091$$

Then the stagnation pressure at the exit and the pressure drop become

$$\frac{P_{02}}{P_{01}} = \frac{P_{02}/P_0^*}{P_{01}/P_0^*} = \frac{1.2091}{1.2346} = 0.9794 \rightarrow P_{02} = 0.9794 P_{01} = 0.9794(617 \text{ kPa}) = 604.3 \text{ kPa}$$

and

$$\Delta P_0 = P_{01} - P_{02} = 617.0 - 604.3 = \mathbf{12.7 \text{ kPa}}$$

Discussion This problem can also be solved using appropriate relations instead of tabulated values, which can likewise be coded for convenient computer solutions.

17-107 Air enters the combustion chamber of a gas turbine at a subsonic velocity. For a specified rate of heat transfer, the Mach number at the exit and the loss in stagnation pressure to be determined.

Assumptions 1 The assumptions associated with Rayleigh flow (i.e., steady one-dimensional flow of an ideal gas with constant properties through a constant cross-sectional area duct with negligible frictional effects) are valid. 2 The cross-sectional area of the combustion chamber is constant. 3 The increase in mass flow rate due to fuel injection is disregarded.

Properties We take the properties of air to be $k = 1.4$, $c_p = 1.005$ kJ/kg·K, and $R = 0.287$ kJ/kg·K.

Analysis The inlet stagnation temperature and pressure are

$$T_{01} = T_1 \left(1 + \frac{k-1}{2} \text{Ma}_1^2 \right) = (700 \text{ K}) \left(1 + \frac{1.4-1}{2} 0.2^2 \right) = 705.6 \text{ K}$$

$$P_{01} = P_1 \left(1 + \frac{k-1}{2} \text{Ma}_1^2 \right)^{k/(k-1)} = (600 \text{ kPa}) \left(1 + \frac{1.4-1}{2} 0.2^2 \right)^{1.4/0.4} = 617.0 \text{ kPa}$$

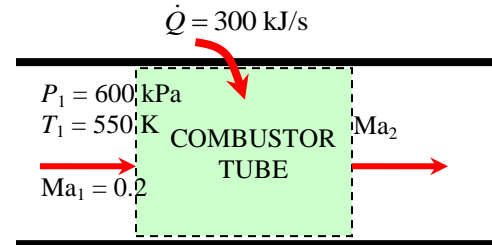

The exit stagnation temperature is determined from

$$\dot{Q} = \dot{m}_{\text{air}} c_p (T_{02} - T_{01}) \rightarrow 300 \text{ kJ/s} = (0.3 \text{ kg/s})(1.005 \text{ kJ/kg} \cdot \text{K})(T_{02} - 705.6 \text{ K})$$

It gives

$$T_{02} = 1701 \text{ K}$$

At $\text{Ma}_1 = 0.2$ we read from $T_{01}/T_0^* = 0.1736$ (Table A-34). Therefore,

$$T_0^* = \frac{T_{01}}{0.1736} = \frac{705.6 \text{ K}}{0.1736} = 4064.5 \text{ K}$$

Then the stagnation temperature ratio at the exit and the Mach number corresponding to it are (Table A-34)

$$\frac{T_{02}}{T_0^*} = \frac{1701 \text{ K}}{4064.5 \text{ K}} = 0.4185 \rightarrow \text{Ma}_2 = 0.3393 \cong \mathbf{0.339}$$

Also,

$$\text{Ma}_1 = 0.2 \rightarrow P_{01}/P_0^* = 1.2346$$

$$\text{Ma}_2 = 0.3393 \rightarrow P_{02}/P_0^* = 1.1820$$

Then the stagnation pressure at the exit and the pressure drop become

$$\frac{P_{02}}{P_{01}} = \frac{P_{02}/P_0^*}{P_{01}/P_0^*} = \frac{1.1820}{1.2346} = 0.9574 \rightarrow P_{02} = 0.9574 P_{01} = 0.9574(617 \text{ kPa}) = 590.7 \text{ kPa}$$

and

$$\Delta P_0 = P_{01} - P_{02} = 617.0 - 590.7 = \mathbf{26.3 \text{ kPa}}$$

Discussion This problem can also be solved using appropriate relations instead of tabulated values, which can likewise be coded for convenient computer solutions.

17-108E Air flowing with a subsonic velocity in a round duct is accelerated by heating until the flow is choked at the exit. The rate of heat transfer and the pressure drop are to be determined.

Assumptions 1 The assumptions associated with Rayleigh flow (i.e., steady one-dimensional flow of an ideal gas with constant properties through a constant cross-sectional area duct with negligible frictional effects) are valid. 2 The flow is choked at the duct exit. 3 Mass flow rate remains constant.

Properties We take the properties of air to be $k = 1.4$, $c_p = 0.2400$ Btu/lbm·R, and $R = 0.06855$ Btu/lbm·R = 0.3704 psia·ft³/lbm·R.

Analysis The inlet density and velocity of air are

$$\rho_1 = \frac{P_1}{RT_1} = \frac{30 \text{ psia}}{(0.3704 \text{ psia} \cdot \text{ft}^3/\text{lbm} \cdot \text{R})(800 \text{ R})} = 0.1012 \text{ lbm/ft}^3$$

$$V_1 = \frac{\dot{m}_{\text{air}}}{\rho_1 A_{c1}} = \frac{5 \text{ lbm/s}}{(0.1012 \text{ lbm/ft}^3)[\pi(4/12 \text{ ft})^2/4]} = 565.9 \text{ ft/s}$$

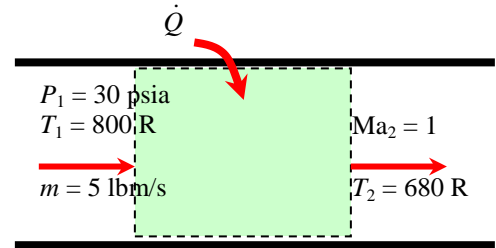

The stagnation temperature and Mach number at the inlet are

$$T_{01} = T_1 + \frac{V_1^2}{2c_p} = 800 \text{ R} + \frac{(565.9 \text{ ft/s})^2}{2 \times 0.2400 \text{ Btu/lbm} \cdot \text{R}} \left(\frac{1 \text{ Btu/lbm}}{25,037 \text{ ft}^2/\text{s}^2} \right) = 826.7 \text{ R}$$

$$c_1 = \sqrt{kRT_1} = \sqrt{(1.4)(0.06855 \text{ Btu/lbm} \cdot \text{R})(800 \text{ R})} \left(\frac{25,037 \text{ ft}^2/\text{s}^2}{1 \text{ Btu/lbm}} \right) = 1386 \text{ ft/s}$$

$$\text{Ma}_1 = \frac{V_1}{c_1} = \frac{565.9 \text{ ft/s}}{1386 \text{ ft/s}} = 0.4082$$

The Rayleigh flow functions corresponding to the inlet and exit Mach numbers are (Table A-34):

$$\text{Ma}_1 = 0.4082: \quad T_1/T^* = 0.6310, \quad P_1/P^* = 1.946, \quad T_{01}/T_0^* = 0.5434$$

$$\text{Ma}_2 = 1: \quad T_2/T^* = 1, \quad P_2/P^* = 1, \quad T_{02}/T_0^* = 1$$

Then the exit temperature, pressure, and stagnation temperature are determined to be

$$\frac{T_2}{T_1} = \frac{T_2/T^*}{T_1/T^*} = \frac{1}{0.6310} \quad \rightarrow \quad T_2 = T_1 / 0.6310 = (800 \text{ R}) / 0.6310 = 1268 \text{ R}$$

$$\frac{P_2}{P_1} = \frac{P_2/P^*}{P_1/P^*} = \frac{1}{1.946} \quad \rightarrow \quad P_2 = P_1 / 1.946 = (30 \text{ psia}) / 1.946 = 15.4 \text{ psia}$$

$$\frac{T_{02}}{T_{01}} = \frac{T_{02}/T_0^*}{T_{01}/T_0^*} = \frac{1}{0.5434} \quad \rightarrow \quad T_{02} = T_{01} / 0.5434 = (826.7 \text{ R}) / 0.5434 = 1521 \text{ R}$$

Then the rate of heat transfer and the pressure drop become

$$\dot{Q} = \dot{m}_{\text{air}} c_p (T_{02} - T_{01}) = (5 \text{ lbm/s})(0.2400 \text{ Btu/lbm} \cdot \text{R})(1521 - 826.7) \text{ R} = \mathbf{834 \text{ Btu/s}}$$

$$\Delta P = P_1 - P_2 = 30 - 15.4 = \mathbf{14.6 \text{ psia}}$$

Discussion Note that the entropy of air increases during this heating process, as expected.



17-109 Air flowing with a subsonic velocity in a duct. The variation of entropy with temperature is to be investigated as the exit temperature varies from 600 K to 5000 K in increments of 200 K. The results are to be tabulated and plotted.

Analysis We solve this problem using EES making use of Rayleigh functions. The EES *Equations* window is printed below, along with the tabulated and plotted results.

```

k=1.4
cp=1.005
R=0.287
P1=350
T1=600
V1=70
C1=sqrt(k*R*T1*1000)
Ma1=V1/C1
T01=T1*(1+0.5*(k-1)*Ma1^2)
P01=P1*(1+0.5*(k-1)*Ma1^2)^(k/(k-1))
F1=1+0.5*(k-1)*Ma1^2
T01Ts=2*(k+1)*Ma1^2*F1/(1+k*Ma1^2)^2
P01Ps=((1+k)/(1+k*Ma1^2))*(2*F1/(k+1))^(k/(k-1))
T1Ts=(Ma1*((1+k)/(1+k*Ma1^2)))^2
P1Ps=(1+k)/(1+k*Ma1^2)
V1Vs=Ma1^2*(1+k)/(1+k*Ma1^2)
F2=1+0.5*(k-1)*Ma2^2
T02Ts=2*(k+1)*Ma2^2*F2/(1+k*Ma2^2)^2
P02Ps=((1+k)/(1+k*Ma2^2))*(2*F2/(k+1))^(k/(k-1))
T2Ts=(Ma2*((1+k)/(1+k*Ma2^2)))^2
P2Ps=(1+k)/(1+k*Ma2^2)
V2Vs=Ma2^2*(1+k)/(1+k*Ma2^2)
T02=T02Ts/T01Ts*T01
P02=P02Ps/P01Ps*P01
T2=T2Ts/T1Ts*T1
P2=P2Ps/P1Ps*P1
V2=V2Vs/V1Vs*V1
Delta_s=cp*ln(T2/T1)-R*ln(P2/P1)

```

Exit temperature T_2 , K	Exit Mach number, Ma_2	Exit entropy relative to inlet, s_2 , kJ/kg·K
600	0.143	0.000
800	0.166	0.292
1000	0.188	0.519
1200	0.208	0.705
1400	0.227	0.863
1600	0.245	1.001
1800	0.263	1.123
2000	0.281	1.232
2200	0.299	1.331
2400	0.316	1.423
2600	0.333	1.507
2800	0.351	1.586
3000	0.369	1.660
3200	0.387	1.729
3400	0.406	1.795
3600	0.426	1.858
3800	0.446	1.918
4000	0.467	1.975
4200	0.490	2.031
4400	0.515	2.085
4600	0.541	2.138

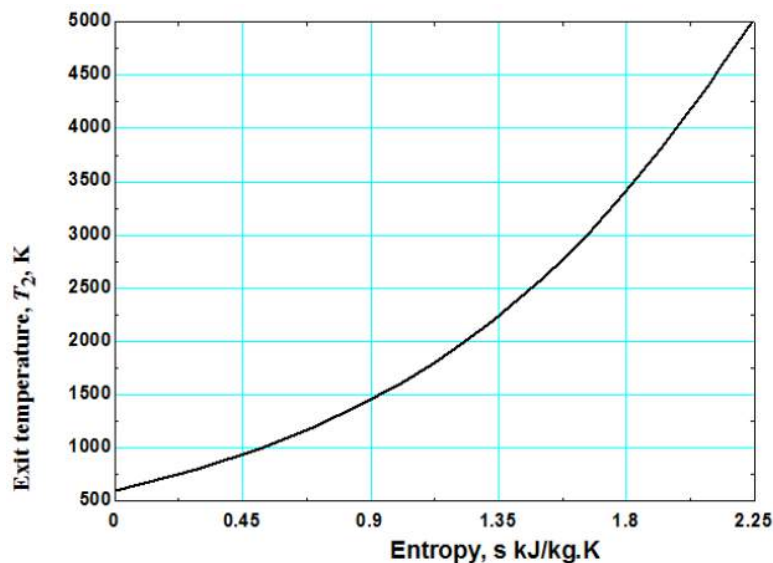

Discussion Note that the entropy of air increases during this heating process, as expected.

17-110E Air flowing with a subsonic velocity in a square duct is accelerated by heating until the flow is choked at the exit. The rate of heat transfer and the entropy change are to be determined.

Assumptions 1 The assumptions associated with Rayleigh flow (i.e., steady one-dimensional flow of an ideal gas with constant properties through a constant cross-sectional area duct with negligible frictional effects) are valid. 2 The flow is choked at the duct exit. 3 Mass flow rate remains constant.

Properties We take the properties of air to be $k = 1.4$, $c_p = 0.2400$ Btu/lbm·R, and $R = 0.06855$ Btu/lbm·R = 0.3704 psia·ft³/lbm·R.

Analysis The inlet density and mass flow rate of air are

$$\rho_1 = \frac{P_1}{RT_1} = \frac{80 \text{ psia}}{(0.3704 \text{ psia} \cdot \text{ft}^3/\text{lbm} \cdot \text{R})(700 \text{ R})} = 0.3085 \text{ lbm/ft}^3$$

$$\dot{m}_{\text{air}} = \rho_1 A_{c1} V_1 = (0.3085 \text{ lbm/ft}^3)(6 \times 6/144 \text{ ft}^2)(260 \text{ ft/s}) = 20.06 \text{ lbm/s}$$

The stagnation temperature and Mach number at the inlet are

$$T_{01} = T_1 + \frac{V_1^2}{2c_p} = 700 \text{ R} + \frac{(260 \text{ ft/s})^2}{2 \times 0.2400 \text{ Btu/lbm} \cdot \text{R}} \left(\frac{1 \text{ Btu/lbm}}{25,037 \text{ ft}^2/\text{s}^2} \right) = 705.6 \text{ R}$$

$$c_1 = \sqrt{kRT_1} = \sqrt{(1.4)(0.06855 \text{ Btu/lbm} \cdot \text{R})(700 \text{ R})} \left(\frac{25,037 \text{ ft}^2/\text{s}^2}{1 \text{ Btu/lbm}} \right) = 1297 \text{ ft/s}$$

$$\text{Ma}_1 = \frac{V_1}{c_1} = \frac{260 \text{ ft/s}}{1297 \text{ ft/s}} = 0.2005$$

The Rayleigh flow functions corresponding to the inlet and exit Mach numbers are (Table A-34):

$$\text{Ma}_1 = 0.2005: \quad T_1/T^* = 0.2075, \quad P_1/P^* = 2.272, \quad T_{01}/T_0^* = 0.1743$$

$$\text{Ma}_2 = 1: \quad T_2/T^* = 1, \quad P_2/P^* = 1, \quad T_{02}/T_0^* = 1$$

Then the exit temperature, pressure, and stagnation temperature are determined to be

$$\frac{T_2}{T_1} = \frac{T_2/T^*}{T_1/T^*} = \frac{1}{0.2075} \quad \rightarrow \quad T_2 = T_1 / 0.2075 = (700 \text{ R}) / 0.2075 = 3374 \text{ R}$$

$$\frac{P_2}{P_1} = \frac{P_2/P^*}{P_1/P^*} = \frac{1}{2.272} \quad \rightarrow \quad P_2 = P_1 / 2.272 = (80 \text{ psia}) / 2.272 = 35.2 \text{ psia}$$

$$\frac{T_{02}}{T_{01}} = \frac{T_{02}/T_0^*}{T_{01}/T_0^*} = \frac{1}{0.1743} \quad \rightarrow \quad T_{02} = T_{01} / 0.1743 = (705.6 \text{ R}) / 0.1743 = 4048 \text{ R}$$

Then the rate of heat transfer and entropy change become

$$\dot{Q} = \dot{m}_{\text{air}} c_p (T_{02} - T_{01}) = (20.06 \text{ lbm/s})(0.2400 \text{ Btu/lbm} \cdot \text{R})(4048 - 705.6) \text{ R} = \mathbf{16,090 \text{ Btu/s}}$$

$$\Delta s = c_p \ln \frac{T_2}{T_1} - R \ln \frac{P_2}{P_1} = (0.2400 \text{ Btu/lbm} \cdot \text{R}) \ln \frac{3374 \text{ R}}{700 \text{ R}} - (0.06855 \text{ Btu/lbm} \cdot \text{R}) \ln \frac{35.2 \text{ psia}}{80 \text{ psia}} = \mathbf{0.434 \text{ Btu/lbm} \cdot \text{R}}$$

Discussion Note that the entropy of air increases during this heating process, as expected.

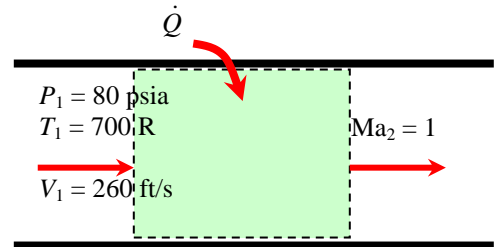

17-111 Fuel is burned in a rectangular duct with compressed air. For specified heat transfer, the exit temperature and Mach number are to be determined.

Assumptions The assumptions associated with Rayleigh flow (i.e., steady one-dimensional flow of an ideal gas with constant properties through a constant cross-sectional area duct with negligible frictional effects) are valid.

Properties We take the properties of air to be $k = 1.4$, $c_p = 1.005 \text{ kJ/kg}\cdot\text{K}$, and $R = 0.287 \text{ kJ/kg}\cdot\text{K}$.

Analysis The stagnation temperature and Mach number at the inlet are

$$c_1 = \sqrt{kRT_1} = \sqrt{(1.4)(0.287 \text{ kJ/kg}\cdot\text{K})(300 \text{ K})\left(\frac{1000 \text{ m}^2/\text{s}^2}{1 \text{ kJ/kg}}\right)} = 347.2 \text{ m/s}$$

$$V_1 = \text{Ma}_1 c_1 = 2(347.2 \text{ m/s}) = 694.4 \text{ m/s}$$

$$T_{01} = T_1 + \frac{V_1^2}{2c_p} = 300 \text{ K} + \frac{(694.4 \text{ m/s})^2}{2 \times 1.005 \text{ kJ/kg}\cdot\text{K}} \left(\frac{1 \text{ kJ/kg}}{1000 \text{ m}^2/\text{s}^2}\right) = 539.9 \text{ K}$$

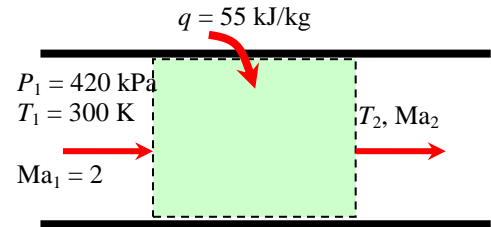

The exit stagnation temperature is, from the energy equation $q = c_p(T_{02} - T_{01})$,

$$T_{02} = T_{01} + \frac{q}{c_p} = 539.9 \text{ K} + \frac{55 \text{ kJ/kg}}{1.005 \text{ kJ/kg}\cdot\text{K}} = 594.6 \text{ K}$$

The maximum value of stagnation temperature T_0^* occurs at $\text{Ma} = 1$, and its value can be determined from Table A-34 or from the appropriate relation. At $\text{Ma}_1 = 2$ we read $T_{01}/T_0^* = 0.7934$. Therefore,

$$T_0^* = \frac{T_{01}}{0.7934} = \frac{539.9 \text{ K}}{0.7934} = 680.5 \text{ K}$$

The stagnation temperature ratio at the exit and the Mach number corresponding to it are, from Table A-34,

$$\frac{T_{02}}{T_0^*} = \frac{594.6 \text{ K}}{680.5 \text{ K}} = 0.8738 \quad \rightarrow \quad \text{Ma}_2 = 1.642 \cong \mathbf{1.64}$$

Also,

$$\text{Ma}_1 = 2 \quad \rightarrow \quad T_1/T^* = 0.5289$$

$$\text{Ma}_2 = 1.642 \quad \rightarrow \quad T_2/T^* = 0.6812$$

Then the exit temperature becomes

$$\frac{T_2}{T_1} = \frac{T_2/T^*}{T_1/T^*} = \frac{0.6812}{0.5289} = 1.288 \quad \rightarrow \quad T_2 = 1.288T_1 = 1.288(300 \text{ K}) = \mathbf{386 \text{ K}}$$

Discussion Note that the temperature increases during this supersonic Rayleigh flow with heating. This problem can also be solved using appropriate relations instead of tabulated values, which can likewise be coded for convenient computer solutions.

17-112 Compressed air is cooled as it flows in a rectangular duct. For specified heat rejection, the exit temperature and Mach number are to be determined.

Assumptions The assumptions associated with Rayleigh flow (i.e., steady one-dimensional flow of an ideal gas with constant properties through a constant cross-sectional area duct with negligible frictional effects) are valid.

Properties We take the properties of air to be $k = 1.4$, $c_p = 1.005 \text{ kJ/kg}\cdot\text{K}$, and $R = 0.287 \text{ kJ/kg}\cdot\text{K}$.

Analysis The stagnation temperature and Mach number at the inlet are

$$c_1 = \sqrt{kRT_1} = \sqrt{(1.4)(0.287 \text{ kJ/kg}\cdot\text{K})(300 \text{ K}) \left(\frac{1000 \text{ m}^2/\text{s}^2}{1 \text{ kJ/kg}} \right)} = 347.2 \text{ m/s}$$

$$V_1 = \text{Ma}_1 c_1 = 2(347.2 \text{ m/s}) = 694.4 \text{ m/s}$$

$$T_{01} = T_1 + \frac{V_1^2}{2c_p} = 300 \text{ K} + \frac{(694.4 \text{ m/s})^2}{2 \times 1.005 \text{ kJ/kg}\cdot\text{K}} \left(\frac{1 \text{ kJ/kg}}{1000 \text{ m}^2/\text{s}^2} \right) = 539.9 \text{ K}$$

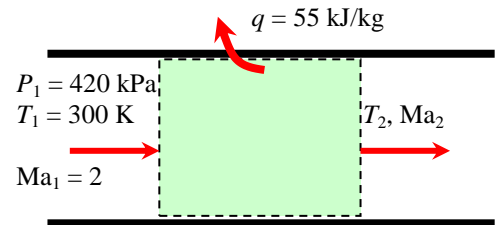

The exit stagnation temperature is, from the energy equation $q = c_p(T_{02} - T_{01})$,

$$T_{02} = T_{01} + \frac{q}{c_p} = 539.9 \text{ K} + \frac{-55 \text{ kJ/kg}}{1.005 \text{ kJ/kg}\cdot\text{K}} = 485.2 \text{ K}$$

The maximum value of stagnation temperature T_0^* occurs at $\text{Ma} = 1$, and its value can be determined from Table A-34 or from the appropriate relation. At $\text{Ma}_1 = 2$ we read $T_{01}/T_0^* = 0.7934$. Therefore,

$$T_0^* = \frac{T_{01}}{0.7934} = \frac{539.9 \text{ K}}{0.7934} = 680.5 \text{ K}$$

The stagnation temperature ratio at the exit and the Mach number corresponding to it are, from Table A-34,

$$\frac{T_{02}}{T_0^*} = \frac{485.2 \text{ K}}{680.5 \text{ K}} = 0.7130 \quad \rightarrow \quad \text{Ma}_2 = 2.479 \cong \mathbf{2.48}$$

Also,

$$\text{Ma}_1 = 2 \quad \rightarrow \quad T_1/T^* = 0.5289$$

$$\text{Ma}_2 = 2.479 \quad \rightarrow \quad T_2/T^* = 0.3838$$

Then the exit temperature becomes

$$\frac{T_2}{T_1} = \frac{T_2/T^*}{T_1/T^*} = \frac{0.3838}{0.5289} = 0.7257 \quad \rightarrow \quad T_2 = 0.7257 T_1 = 0.7257(300 \text{ K}) = \mathbf{218 \text{ K}}$$

Discussion Note that the temperature decreases and Mach number increases during this supersonic Rayleigh flow with cooling. This problem can also be solved using appropriate relations instead of tabulated values, which can likewise be coded for convenient computer solutions.

17-113 Fuel is burned in a tubular combustion chamber with compressed air. For a specified exit Mach number, the exit temperature and the rate of fuel consumption are to be determined.

Assumptions 1 The assumptions associated with Rayleigh flow (i.e., steady one-dimensional flow of an ideal gas with constant properties through a constant cross-sectional area duct with negligible frictional effects) are valid. 2 Combustion is complete, and it is treated as a heat addition process, with no change in the chemical composition of flow. 3 The increase in mass flow rate due to fuel injection is disregarded.

Properties We take the properties of air to be $k = 1.4$, $c_p = 1.005$ kJ/kg·K, and $R = 0.287$ kJ/kg·K.

Analysis The inlet density and mass flow rate of air are

$$\rho_1 = \frac{P_1}{RT_1} = \frac{380 \text{ kPa}}{(0.287 \text{ kJ/kg}\cdot\text{K})(450 \text{ K})} = 2.942 \text{ kg/m}^3$$

$$\dot{m}_{\text{air}} = \rho_1 A_{c1} V_1 = (2.942 \text{ kg/m}^3) [\pi(0.16 \text{ m})^2 / 4] (55 \text{ m/s}) = 3.254 \text{ kg/s}$$

The stagnation temperature and Mach number at the inlet are

$$T_{01} = T_1 + \frac{V_1^2}{2c_p} = 450 \text{ K} + \frac{(55 \text{ m/s})^2}{2 \times 1.005 \text{ kJ/kg}\cdot\text{K}} \left(\frac{1 \text{ kJ/kg}}{1000 \text{ m}^2/\text{s}^2} \right) = 451.5 \text{ K}$$

$$c_1 = \sqrt{kRT_1} = \sqrt{(1.4)(0.287 \text{ kJ/kg}\cdot\text{K})(450 \text{ K})} \left(\frac{1000 \text{ m}^2/\text{s}^2}{1 \text{ kJ/kg}} \right) = 425.2 \text{ m/s}$$

$$\text{Ma}_1 = \frac{V_1}{c_1} = \frac{55 \text{ m/s}}{425.2 \text{ m/s}} = 0.1293$$

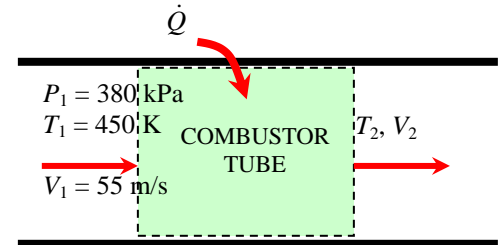

The Rayleigh flow functions corresponding to the inlet and exit Mach numbers are (Table A-34) (We used analytical functions):

$$\text{Ma}_1 = 0.1293: \quad T_1/T^* = 0.09201, \quad T_{01}/T^* = 0.07693, \quad V_1/V^* = 0.03923$$

$$\text{Ma}_2 = 0.8: \quad T_2/T^* = 1.0255, \quad T_{02}/T^* = 0.9639, \quad V_2/V^* = 0.8101$$

The exit temperature, stagnation temperature, and velocity are determined to be

$$\frac{T_2}{T_1} = \frac{T_2/T^*}{T_1/T^*} = \frac{1.0255}{0.09201} = 11.146 \rightarrow T_2 = 11.146 T_1 = 11.146(450 \text{ K}) = \mathbf{5016 \text{ K}}$$

$$\frac{T_{02}}{T_{01}} = \frac{T_{02}/T^*}{T_{01}/T^*} = \frac{0.9639}{0.07693} = 12.530 \rightarrow T_{02} = 12.530 T_{01} = 12.530(451.5 \text{ K}) = 5658 \text{ K}$$

$$\frac{V_2}{V_1} = \frac{V_2/V^*}{V_1/V^*} = \frac{0.8101}{0.03923} = 20.650 \rightarrow V_2 = 20.650 V_1 = 20.650(55 \text{ m/s}) = 1136 \text{ m/s}$$

Then the mass flow rate of the fuel is determined to be

$$q = c_p (T_{02} - T_{01}) = (1.005 \text{ kJ/kg}\cdot\text{K})(5658 - 451.5) \text{ K} = 5232 \text{ kJ/kg}$$

$$\dot{Q} = \dot{m}_{\text{air}} q = (3.254 \text{ kg/s})(5232 \text{ kJ/kg}) = 17,024 \text{ kW}$$

$$\dot{m}_{\text{fuel}} = \frac{\dot{Q}}{HV} = \frac{17,024 \text{ kJ/s}}{39,000 \text{ kJ/kg}} = \mathbf{0.4365 \text{ kg/s}}$$

Discussion Note that both the temperature and velocity increase during this subsonic Rayleigh flow with heating, as expected. This problem can also be solved using appropriate relations instead of tabulated values, which can likewise be coded for convenient computer solutions.

17-114 Air flowing at a supersonic velocity in a duct is decelerated by heating. The highest temperature air can be heated by heat addition and the rate of heat transfer are to be determined.

Assumptions 1 The assumptions associated with Rayleigh flow (i.e., steady one-dimensional flow of an ideal gas with constant properties through a constant cross-sectional area duct with negligible frictional effects) are valid. 2 Mass flow rate remains constant.

Properties We take the properties of air to be $k = 1.4$, $c_p = 1.005 \text{ kJ/kg}\cdot\text{K}$, and $R = 0.287 \text{ kJ/kg}\cdot\text{K}$.

Analysis Heat transfer will stop when the flow is choked, and thus $\text{Ma}_2 = V_2/c_2 = 1$. Knowing stagnation properties, the static properties are determined to be

$$T_1 = T_{01} \left(1 + \frac{k-1}{2} \text{Ma}_1^2 \right)^{-1} = (600 \text{ K}) \left(1 + \frac{1.4-1}{2} 1.8^2 \right)^{-1} = 364.1 \text{ K}$$

$$P_1 = P_{01} \left(1 + \frac{k-1}{2} \text{Ma}_1^2 \right)^{-k/(k-1)} = (140 \text{ kPa}) \left(1 + \frac{1.4-1}{2} 1.8^2 \right)^{-1.4/0.4} \\ = 24.37 \text{ kPa}$$

$$\rho_1 = \frac{P_1}{RT_1} = \frac{24.37 \text{ kPa}}{(0.287 \text{ kJ/kg}\cdot\text{K})(364.1 \text{ K})} = 0.2332 \text{ kg/m}^3$$

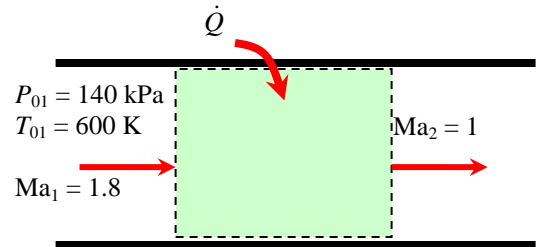

Then the inlet velocity and the mass flow rate become

$$c_1 = \sqrt{kRT_1} = \sqrt{(1.4)(0.287 \text{ kJ/kg}\cdot\text{K})(364.1 \text{ K}) \left(\frac{1000 \text{ m}^2/\text{s}^2}{1 \text{ kJ/kg}} \right)} = 382.5 \text{ m/s}$$

$$V_1 = \text{Ma}_1 c_1 = 1.8(382.5 \text{ m/s}) = 688.5 \text{ m/s}$$

$$\dot{m}_{air} = \rho_1 A_{c1} V_1 = (0.2332 \text{ kg/m}^3) [\pi(0.07 \text{ m})^2 / 4] (688.5 \text{ m/s}) = 0.6179 \text{ kg/s}$$

The Rayleigh flow functions corresponding to the inlet and exit Mach numbers are (Table A-34):

$$\text{Ma}_1 = 1.8: \quad T_1/T^* = 0.6089, \quad T_{01}/T_0^* = 0.8363$$

$$\text{Ma}_2 = 1: \quad T_2/T^* = 1, \quad T_{02}/T_0^* = 1$$

Then the exit temperature and stagnation temperature are determined to be

$$\frac{T_2}{T_1} = \frac{T_2/T^*}{T_1/T^*} = \frac{1}{0.6089} \quad \rightarrow \quad T_2 = T_1 / 0.6089 = (364.1 \text{ K}) / 0.6089 = \mathbf{598 \text{ K}}$$

$$\frac{T_{02}}{T_{01}} = \frac{T_{02}/T_0^*}{T_{01}/T_0^*} = \frac{1}{0.8363} \quad \rightarrow \quad T_{02} = T_{01} / 0.8363 = (600 \text{ K}) / 0.8363 = 717.4 \text{ K} \cong \mathbf{717 \text{ K}}$$

Finally, the rate of heat transfer is

$$\dot{Q} = \dot{m}_{air} c_p (T_{02} - T_{01}) = (0.6179 \text{ kg/s})(1.005 \text{ kJ/kg}\cdot\text{K})(717.4 - 600) \text{ K} = \mathbf{72.9 \text{ kW}}$$

Discussion Note that this is the highest temperature that can be attained under stated conditions. If more heat is transferred, the additional temperature will cause the mass flow rate to decrease. Also, once the sonic conditions are reached, the thermodynamic temperature can be increased further by cooling the fluid and reducing the velocity (see the T - s diagram for Rayleigh flow).

Steam Nozzles

17-115C The delay in the condensation of the steam is called supersaturation. It occurs in high-speed flows where there isn't sufficient time for the necessary heat transfer and the formation of liquid droplets.

17-116 Steam enters a converging nozzle with a low velocity. The exit velocity, mass flow rate, and exit Mach number are to be determined for isentropic and 94 percent efficient nozzle cases.

Assumptions 1 Flow through the nozzle is steady and one-dimensional. **2** The nozzle is adiabatic.

Analysis (a) The inlet stagnation properties in this case are identical to the inlet properties since the inlet velocity is negligible. Thus $h_{01} = h_1$.

At the inlet,

$$\left. \begin{aligned} P_1 = P_{01} = 5 \text{ MPa} \\ T_1 = T_{01} = 400^\circ\text{C} \end{aligned} \right\} \begin{aligned} h_1 = h_{01} = 3196.7 \text{ kJ/kg} \\ s_1 = s_{2s} = 6.6483 \text{ kJ/kg} \cdot \text{K} \end{aligned}$$

At the exit,

$$\left. \begin{aligned} P_2 = 3 \text{ MPa} \\ s_2 = 6.6483 \text{ kJ/kg} \cdot \text{K} \end{aligned} \right\} \begin{aligned} h_2 = 3057.0 \text{ kJ/kg} \\ v_2 = 0.08601 \text{ m}^3/\text{kg} \end{aligned}$$

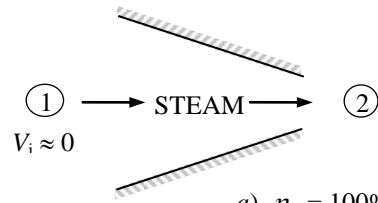

- a) $\eta_N = 100\%$
b) $\eta_N = 94\%$

Then the exit velocity is determined from the steady-flow energy balance $\dot{E}_{\text{in}} = \dot{E}_{\text{out}}$ with $q = w = 0$,

$$h_1 + V_1^2/2 = h_2 + V_2^2/2 \longrightarrow 0 = h_2 - h_1 + \frac{V_2^2 - V_1^2}{2}$$

Solving for V_2 ,

$$V_2 = \sqrt{2(h_1 - h_2)} = \sqrt{2(3196.7 - 3057.0) \text{ kJ/kg} \left(\frac{1000 \text{ m}^2/\text{s}^2}{1 \text{ kJ/kg}} \right)} = \mathbf{528.5 \text{ m/s}}$$

The mass flow rate is determined from

$$\dot{m} = \frac{1}{v_2} A_2 V_2 = \frac{1}{0.08601 \text{ m}^3/\text{kg}} (60 \times 10^{-4} \text{ m}^2)(528.5 \text{ m/s}) = \mathbf{36.86 \text{ kg/s}}$$

The velocity of sound at the exit of the nozzle is determined from

$$c = \left(\frac{\partial \mathcal{P}}{\partial \rho} \right)_s \cong \left(\frac{\Delta \mathcal{P}}{\Delta(1/v)} \right)_s$$

The specific volume of steam at $s_2 = 6.6483 \text{ kJ/kg} \cdot \text{K}$ and at pressures just below and just above the specified pressure (2.5 and 3.5 MPa) are determined to be 0.09906 and 0.07632 m^3/kg . Substituting,

$$c_2 = \sqrt{\frac{(3500 - 2500) \text{ kPa}}{\left(\frac{1}{0.07632} - \frac{1}{0.09906} \right) \text{ kg/m}^3} \left(\frac{1000 \text{ m}^2/\text{s}^2}{1 \text{ kPa} \cdot \text{m}^3} \right)} = 576.6 \text{ m/s}$$

Then the exit Mach number becomes

$$\text{Ma}_2 = \frac{V_2}{c_2} = \frac{528.5 \text{ m/s}}{576.6 \text{ m/s}} = \mathbf{0.917}$$

(b) The inlet stagnation properties in this case are identical to the inlet properties since the inlet velocity is negligible. Thus $h_{01} = h_1$.

At the inlet,

$$\left. \begin{aligned} P_1 = P_{01} = 5 \text{ MPa} \\ T_1 = T_{01} = 400^\circ\text{C} \end{aligned} \right\} \begin{aligned} h_1 = h_{01} = 3196.7 \text{ kJ/kg} \\ s_1 = s_{2s} = 6.6483 \text{ kJ/kg} \cdot \text{K} \end{aligned}$$

At state 2s,

$$\left. \begin{array}{l} P_{2s} = 3 \text{ MPa} \\ s_{2s} = 6.6483 \text{ kJ/kg} \cdot \text{K} \end{array} \right\} h_{2s} = 3057.0 \text{ kJ/kg}$$

The enthalpy of steam at the actual exit state is determined from

$$\eta_N = \frac{h_{01} - h_2}{h_{01} - h_{2s}} \longrightarrow 0.94 = \frac{3196.7 - h_2}{3196.7 - 3057.0} \longrightarrow h_2 = 3065.4 \text{ kJ/kg}$$

Therefore,

$$\left. \begin{array}{l} P_2 = 3 \text{ MPa} \\ h_2 = 3065.4 \text{ kJ/kg} \end{array} \right\} \begin{array}{l} v_2 = 0.08666 \text{ m}^3/\text{kg} \\ s_2 = 6.6622 \text{ kJ/kg} \cdot \text{K} \end{array}$$

Then the exit velocity is determined from the steady-flow energy balance $\dot{E}_{\text{in}} = \dot{E}_{\text{out}}$ with $q = w = 0$,

$$h_1 + V_1^2/2 = h_2 + V_2^2/2 \longrightarrow 0 = h_2 - h_1 + \frac{V_2^2 - V_1^2}{2}$$

Solving for V_2 ,

$$V_2 = \sqrt{2(h_1 - h_2)} = \sqrt{2(3196.7 - 3065.4) \text{ kJ/kg} \left(\frac{1000 \text{ m}^2/\text{s}^2}{1 \text{ kJ/kg}} \right)} = \mathbf{512.4 \text{ m/s}}$$

The mass flow rate is determined from

$$\dot{m} = \frac{1}{v_2} A_2 V_2 = \frac{1}{0.08666 \text{ m}^3/\text{kg}} (60 \times 10^{-4} \text{ m}^2)(512.4 \text{ m/s}) = \mathbf{35.47 \text{ kg/s}}$$

The velocity of sound at the exit of the nozzle is determined from

$$c = \left(\frac{\partial \mathcal{P}}{\partial \rho} \right)_s \cong \left(\frac{\Delta \mathcal{P}}{\Delta(1/v)} \right)_s^{1/2}$$

The specific volume of steam at $s_2 = 6.6622 \text{ kJ/kg} \cdot \text{K}$ and at pressures just below and just above the specified pressure (2.5 and 3.5 MPa) are determined to be 0.09981 and 0.07689 m^3/kg . Substituting,

$$c_2 = \sqrt{\frac{(3500 - 2500) \text{ kPa}}{\left(\frac{1}{0.07689} - \frac{1}{0.09981} \right) \text{ kg/m}^3} \left(\frac{1000 \text{ m}^2/\text{s}^2}{1 \text{ kPa} \cdot \text{m}^3} \right)} = 578.7 \text{ m/s}$$

Then the exit Mach number becomes

$$\text{Ma}_2 = \frac{V_2}{c_2} = \frac{512.4 \text{ m/s}}{578.7 \text{ m/s}} = \mathbf{0.885}$$

17-117E Steam enters a converging nozzle with a low velocity. The exit velocity, mass flow rate, and exit Mach number are to be determined for isentropic and 90 percent efficient nozzle cases.

Assumptions 1 Flow through the nozzle is steady and one-dimensional. **2** The nozzle is adiabatic.

Analysis (a) The inlet stagnation properties in this case are identical to the inlet properties since the inlet velocity is negligible. Thus $h_{01} = h_1$.

At the inlet,

$$\left. \begin{aligned} P_1 = P_{01} = 450 \text{ psia} \\ T_1 = T_{01} = 900^\circ\text{F} \end{aligned} \right\} \begin{aligned} h_1 = h_{01} = 1468.6 \text{ Btu/lbm} \\ s_1 = s_{2s} = 1.7117 \text{ Btu/lbm} \cdot \text{R} \end{aligned}$$

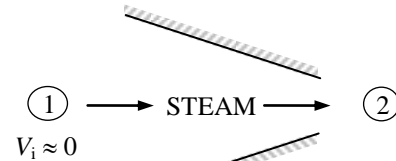

At the exit,

$$\left. \begin{aligned} P_2 = 275 \text{ psia} \\ s_{2s} = 1.7117 \text{ Btu/lbm} \cdot \text{R} \end{aligned} \right\} \begin{aligned} h_2 = 1400.5 \text{ Btu/lbm} \\ v_2 = 2.5732 \text{ ft}^3/\text{lbm} \end{aligned}$$

- a) $\eta_N = 100\%$
b) $\eta_N = 90\%$

Then the exit velocity is determined from the steady-flow energy balance $\dot{E}_{\text{in}} = \dot{E}_{\text{out}}$ with $q = w = 0$,

$$h_1 + V_1^2/2 = h_2 + V_2^2/2 \longrightarrow 0 = h_2 - h_1 + \frac{V_2^2 - V_1^2}{2}$$

Solving for V_2 ,

$$V_2 = \sqrt{2(h_1 - h_2)} = \sqrt{2(1468.6 - 1400.5) \text{ Btu/lbm} \left(\frac{25,037 \text{ ft}^2/\text{s}^2}{1 \text{ Btu/lbm}} \right)} = \mathbf{1847 \text{ ft/s}}$$

Then,

$$\dot{m} = \frac{1}{v_2} A_2 V_2 = \frac{1}{2.5732 \text{ ft}^3/\text{lbm}} (3.75/144 \text{ ft}^2)(1847 \text{ ft/s}) = \mathbf{18.71 \text{ lbm/s}}$$

The velocity of sound at the exit of the nozzle is determined from

$$c = \left(\frac{\partial \mathcal{P}}{\partial \rho} \right)_s \cong \left(\frac{\Delta \mathcal{P}}{\Delta(1/v)} \right)_s$$

The specific volume of steam at $s_2 = 1.7117 \text{ Btu/lbm} \cdot \text{R}$ and at pressures just below and just above the specified pressure (250 and 300 psia) are determined to be 2.7709 and 2.4048 ft^3/lbm . Substituting,

$$c_2 = \sqrt{\frac{(300 - 250) \text{ psia}}{\left(\frac{1}{2.4048} - \frac{1}{2.7709} \right) \text{ lbm/ft}^3} \left(\frac{25,037 \text{ ft}^2/\text{s}^2}{1 \text{ Btu/lbm}} \right) \left(\frac{1 \text{ Btu}}{5.4039 \text{ ft}^3 \cdot \text{psia}} \right)} = 2053 \text{ ft/s}$$

Then the exit Mach number becomes

$$\text{Ma}_2 = \frac{V_2}{c_2} = \frac{1847 \text{ ft/s}}{2053 \text{ ft/s}} = \mathbf{0.900}$$

(b) The inlet stagnation properties in this case are identical to the inlet properties since the inlet velocity is negligible. Thus $h_{01} = h_1$.

At the inlet,

$$\left. \begin{aligned} P_1 = P_{01} = 450 \text{ psia} \\ T_1 = T_{01} = 900^\circ\text{F} \end{aligned} \right\} \begin{aligned} h_1 = h_{01} = 1468.6 \text{ Btu/lbm} \\ s_1 = s_{2s} = 1.7117 \text{ Btu/lbm} \cdot \text{R} \end{aligned}$$

At state 2s,

$$\left. \begin{array}{l} P_{2s} = 275 \text{ psia} \\ s_{2s} = 1.7117 \text{ Btu/lbm} \cdot \text{R} \end{array} \right\} h_{2s} = 1400.5 \text{ Btu/lbm}$$

The enthalpy of steam at the actual exit state is determined from

$$\eta_N = \frac{h_{01} - h_2}{h_{01} - h_{2s}} \longrightarrow 0.90 = \frac{1468.6 - h_2}{1468.6 - 1400.5} \longrightarrow h_2 = 1407.3 \text{ Btu/lbm}$$

Therefore,

$$\left. \begin{array}{l} P_2 = 275 \text{ psia} \\ h_2 = 1407.3 \text{ Btu/lbm} \end{array} \right\} \begin{array}{l} v_2 = 2.6034 \text{ ft}^3/\text{lbm} \\ s_2 = 1.7173 \text{ Btu/lbm} \cdot \text{R} \end{array}$$

Then the exit velocity is determined from the steady-flow energy balance $\dot{E}_{\text{in}} = \dot{E}_{\text{out}}$ with $q = w = 0$,

$$h_1 + V_1^2/2 = h_2 + V_2^2/2 \longrightarrow 0 = h_2 - h_1 + \frac{V_2^2 - V_1^2}{2}$$

Solving for V_2 ,

$$V_2 = \sqrt{2(h_1 - h_2)} = \sqrt{2(1468.6 - 1407.3) \text{ Btu/lbm} \left(\frac{25,037 \text{ ft}^2/\text{s}^2}{1 \text{ Btu/lbm}} \right)} = \mathbf{1752 \text{ ft/s}}$$

Then,

$$\dot{m} = \frac{1}{v_2} A_2 V_2 = \frac{1}{2.6034 \text{ ft}^3/\text{lbm}} (3.75/144 \text{ ft}^2)(1752 \text{ ft/s}) = \mathbf{17.531 \text{ lbm/s}}$$

The velocity of sound at the exit of the nozzle is determined from

$$c = \left(\frac{\partial \mathcal{P}}{\partial \rho} \right)_s^{1/2} \cong \left(\frac{\Delta \mathcal{P}}{\Delta(1/v)} \right)_s^{1/2}$$

The specific volume of steam at $s_2 = 1.7173 \text{ Btu/lbm} \cdot \text{R}$ and at pressures just below and just above the specified pressure (250 and 300 psia) are determined to be 2.8036 and 2.4329 ft^3/lbm . Substituting,

$$c_2 = \sqrt{\frac{(300 - 250) \text{ psia}}{\left(\frac{1}{2.4329} - \frac{1}{2.8036} \right) \text{ lbm/ft}^3} \left(\frac{25,037 \text{ ft}^2/\text{s}^2}{1 \text{ Btu/lbm}} \right) \left(\frac{1 \text{ Btu}}{5.4039 \text{ ft}^3 \cdot \text{psia}} \right)} = 2065 \text{ ft/s}$$

Then the exit Mach number becomes

$$\text{Ma}_2 = \frac{V_2}{c_2} = \frac{1752 \text{ ft/s}}{2065 \text{ ft/s}} = \mathbf{0.849}$$

17-118 Steam enters a converging-diverging nozzle with a low velocity. The exit area and the exit Mach number are to be determined.

Assumptions Flow through the nozzle is steady, one-dimensional, and isentropic.

Analysis The inlet stagnation properties in this case are identical to the inlet properties since the inlet velocity is negligible. Thus $h_{01} = h_1$.

At the inlet,

$$\left. \begin{aligned} P_1 = P_{01} = 1 \text{ MPa} \\ T_1 = T_{01} = 500^\circ\text{C} \end{aligned} \right\} \begin{aligned} h_1 = h_{01} = 3479.1 \text{ kJ/kg} \\ s_1 = s_{2s} = 7.7642 \text{ kJ/kg} \cdot \text{K} \end{aligned}$$

At the exit,

$$\left. \begin{aligned} P_2 = 0.2 \text{ MPa} \\ s_2 = 7.7642 \text{ kJ/kg} \cdot \text{K} \end{aligned} \right\} \begin{aligned} h_2 = 3000.0 \text{ kJ/kg} \\ v_2 = 1.2325 \text{ m}^3/\text{kg} \end{aligned}$$

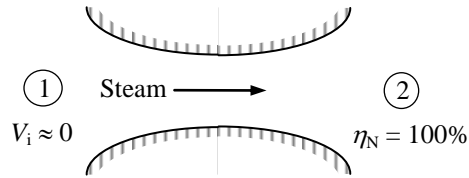

Then the exit velocity is determined from the steady-flow energy balance $\dot{E}_{\text{in}} = \dot{E}_{\text{out}}$ with $q = w = 0$,

$$h_1 + V_1^2/2 = h_2 + V_2^2/2 \longrightarrow 0 = h_2 - h_1 + \frac{V_2^2 - V_1^2}{2}$$

Solving for V_2 ,

$$V_2 = \sqrt{2(h_1 - h_2)} = \sqrt{2(3479.1 - 3000.0) \text{ kJ/kg} \left(\frac{1000 \text{ m}^2/\text{s}^2}{1 \text{ kJ/kg}} \right)} = 978.9 \text{ m/s}$$

The exit area is determined from

$$A_2 = \frac{\dot{m} v_2}{V_2} = \frac{(2.5 \text{ kg/s})(1.2325 \text{ m}^3/\text{kg})}{(978.9 \text{ m/s})} = 31.5 \times 10^{-4} \text{ m}^2 = \mathbf{31.5 \text{ cm}^2}$$

The velocity of sound at the exit of the nozzle is determined from

$$c = \left(\frac{\partial P}{\partial \rho} \right)_s^{1/2} \cong \left(\frac{\Delta P}{\Delta(1/v)} \right)_s^{1/2}$$

The specific volume of steam at $s_2 = 7.7642 \text{ kJ/kg} \cdot \text{K}$ and at pressures just below and just above the specified pressure (0.1 and 0.3 MPa) are determined to be 2.0935 and 0.9024 m^3/kg . Substituting,

$$c_2 = \sqrt{\frac{(300 - 100) \text{ kPa}}{\left(\frac{1}{0.9024} - \frac{1}{2.0935} \right) \text{ kg/m}^3} \left(\frac{1000 \text{ m}^2/\text{s}^2}{1 \text{ kPa} \cdot \text{m}^3} \right)} = 563.2 \text{ m/s}$$

Then the exit Mach number becomes

$$\text{Ma}_2 = \frac{V_2}{c_2} = \frac{978.9 \text{ m/s}}{563.2 \text{ m/s}} = \mathbf{1.738}$$

17-119 Steam enters a converging-diverging nozzle with a low velocity. The exit area and the exit Mach number are to be determined.

Assumptions Flow through the nozzle is steady and one-dimensional.

Analysis The inlet stagnation properties in this case are identical to the inlet properties since the inlet velocity is negligible. Thus $h_{01} = h_1$.

$$\text{At the inlet, } \left. \begin{array}{l} P_1 = P_{01} = 1 \text{ MPa} \\ T_1 = T_{01} = 500^\circ\text{C} \end{array} \right\} \begin{array}{l} h_1 = h_{01} = 3479.1 \text{ kJ/kg} \\ s_1 = s_{2s} = 7.7642 \text{ kJ/kg} \cdot \text{K} \end{array}$$

$$\text{At state } 2s, \left. \begin{array}{l} P_2 = 0.2 \text{ MPa} \\ s_2 = 7.7642 \text{ kJ/kg} \cdot \text{K} \end{array} \right\} h_{2s} = 3000.0 \text{ kJ/kg}$$

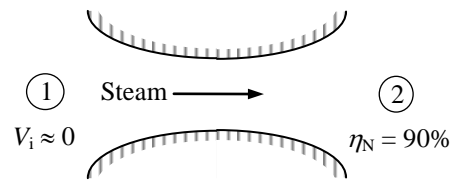

The enthalpy of steam at the actual exit state is determined from

$$\eta_N = \frac{h_{01} - h_2}{h_{01} - h_{2s}} \longrightarrow 0.90 = \frac{3479.1 - h_2}{3479.1 - 3000.0} \longrightarrow h_2 = 3047.9 \text{ kJ/kg}$$

Therefore,

$$\left. \begin{array}{l} P_2 = 0.2 \text{ MPa} \\ h_2 = 3047.9 \text{ kJ/kg} \end{array} \right\} \begin{array}{l} v_2 = 1.2882 \text{ m}^3/\text{kg} \\ s_2 = 7.7642 \text{ kJ/kg} \cdot \text{K} \end{array}$$

Then the exit velocity is determined from the steady-flow energy balance $\dot{E}_{\text{in}} = \dot{E}_{\text{out}}$ with $q = w = 0$,

$$h_1 + V_1^2/2 = h_2 + V_2^2/2 \longrightarrow 0 = h_2 - h_1 + \frac{V_2^2 - V_1^2}{2}$$

Solving for V_2 ,

$$V_2 = \sqrt{2(h_1 - h_2)} = \sqrt{2(3479.1 - 3047.9) \text{ kJ/kg} \left(\frac{1000 \text{ m}^2/\text{s}^2}{1 \text{ kJ/kg}} \right)} = 928.7 \text{ m/s}$$

The exit area is determined from

$$A_2 = \frac{\dot{m} v_2}{V_2} = \frac{(2.5 \text{ kg/s})(1.2882 \text{ m}^3/\text{kg})}{928.7 \text{ m/s}} = 34.7 \times 10^{-4} \text{ m}^2 = \mathbf{34.7 \text{ cm}^2}$$

The velocity of sound at the exit of the nozzle is determined from

$$c = \left(\frac{\partial P}{\partial \rho} \right)_s^{1/2} \cong \left(\frac{\Delta P}{\Delta(1/v)} \right)_s^{1/2}$$

The specific volume of steam at $s_2 = 7.7642 \text{ kJ/kg} \cdot \text{K}$ and at pressures just below and just above the specified pressure (0.1 and 0.3 MPa) are determined to be 2.1903 and 0.9425 m^3/kg . Substituting,

$$c_2 = \sqrt{\frac{(300 - 100) \text{ kPa}}{\left(\frac{1}{0.9425} - \frac{1}{2.1903} \right) \text{ kg/m}^3} \left(\frac{1000 \text{ m}^2/\text{s}^2}{1 \text{ kPa} \cdot \text{m}^3} \right)} = 575.2 \text{ m/s}$$

Then the exit Mach number becomes

$$\text{Ma}_2 = \frac{V_2}{c_2} = \frac{928.7 \text{ m/s}}{575.2 \text{ m/s}} = \mathbf{1.61}$$

Review Problems

17-120 The thrust developed by the engine of a Boeing 777 is about 380 kN. The mass flow rate of gases through the nozzle is to be determined.

Assumptions 1 Air is an ideal gas with constant specific heats. 2 Flow of combustion gases through the nozzle is isentropic. 3 Choked flow conditions exist at the nozzle exit. 4 The velocity of gases at the nozzle inlet is negligible.

Properties The gas constant of air is $R = 0.287 \text{ kPa}\cdot\text{m}^3/\text{kg}\cdot\text{K}$, and it can also be used for combustion gases. The specific heat ratio of combustion gases is $k = 1.33$.

Analysis The velocity at the nozzle exit is the sonic speed, which is determined to be

$$V = c = \sqrt{kRT} = \sqrt{(1.33)(0.287 \text{ kJ/kg}\cdot\text{K})\left(\frac{1000 \text{ m}^2/\text{s}^2}{1 \text{ kJ/kg}}\right)(220 \text{ K})} = 289.8 \text{ m/s}$$

Noting that thrust F is related to velocity by $F = \dot{m}V$, the mass flow rate of combustion gases is determined to be

$$\dot{m} = \frac{F}{V} = \frac{380,000 \text{ N}}{289.8 \text{ m/s}} \left(\frac{1 \text{ kg}\cdot\text{m}/\text{s}^2}{1 \text{ N}} \right) = 1311 \text{ kg/s} \cong \mathbf{1310 \text{ kg/s}}$$

Discussion The combustion gases are mostly nitrogen (due to the 78% of N_2 in air), and thus they can be treated as air with a good degree of approximation.

17-121 A stationary temperature probe is inserted into an air duct reads 85°C . The actual temperature of air is to be determined.

Assumptions 1 Air is an ideal gas with constant specific heats at room temperature. 2 The stagnation process is isentropic.

Properties The specific heat of air at room temperature is $c_p = 1.005 \text{ kJ/kg}\cdot\text{K}$.

Analysis The air that strikes the probe will be brought to a complete stop, and thus it will undergo a stagnation process. The thermometer will sense the temperature of this stagnated air, which is the stagnation temperature. The actual air temperature is determined from

$$T = T_0 - \frac{V^2}{2c_p} = 85^\circ\text{C} - \frac{(190 \text{ m/s})^2}{2 \times 1.005 \text{ kJ/kg}\cdot\text{K}} \left(\frac{1 \text{ kJ/kg}}{1000 \text{ m}^2/\text{s}^2} \right) = \mathbf{67.0^\circ\text{C}}$$

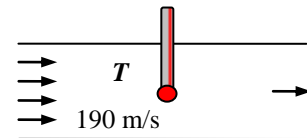

Discussion Temperature rise due to stagnation is very significant in high-speed flows, and should always be considered when compressibility effects are not negligible.

17-122 Nitrogen flows through a heat exchanger. The stagnation pressure and temperature of the nitrogen at the inlet and the exit states are to be determined.

Assumptions 1 Nitrogen is an ideal gas with constant specific heats. 2 Flow of nitrogen through the heat exchanger is isentropic.

Properties The properties of nitrogen are $c_p = 1.039 \text{ kJ/kg}\cdot\text{K}$ and $k = 1.4$.

Analysis The stagnation temperature and pressure of nitrogen at the inlet and the exit states are determined from

$$T_{01} = T_1 + \frac{V_1^2}{2c_p} = 10^\circ\text{C} + \frac{(100 \text{ m/s})^2}{2 \times 1.039 \text{ kJ/kg}\cdot^\circ\text{C}} \left(\frac{1 \text{ kJ/kg}}{1000 \text{ m}^2/\text{s}^2} \right) = \mathbf{14.8^\circ\text{C}}$$

$$P_{01} = P_1 \left(\frac{T_{01}}{T_1} \right)^{k/(k-1)} = (150 \text{ kPa}) \left(\frac{288.0 \text{ K}}{283.2 \text{ K}} \right)^{1.4/(1.4-1)} = \mathbf{159 \text{ kPa}}$$

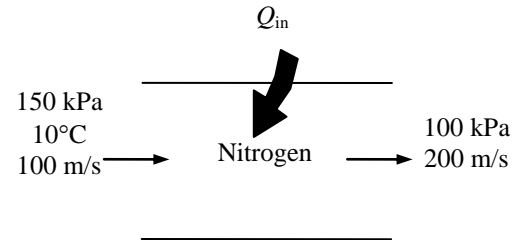

From the energy balance relation $E_{in} - E_{out} = \Delta E_{system}$ with $w = 0$

$$q_{in} = c_p(T_2 - T_1) + \frac{V_2^2 - V_1^2}{2} + \Delta pe \approx 0$$

$$150 \text{ kJ/kg} = (1.039 \text{ kJ/kg}\cdot^\circ\text{C})(T_2 - 10^\circ\text{C}) + \frac{(200 \text{ m/s})^2 - (100 \text{ m/s})^2}{2} \left(\frac{1 \text{ kJ/kg}}{1000 \text{ m}^2/\text{s}^2} \right)$$

$$T_2 = 139.9^\circ\text{C}$$

and

$$T_{02} = T_2 + \frac{V_2^2}{2c_p} = 139.9^\circ\text{C} + \frac{(200 \text{ m/s})^2}{2 \times 1.039 \text{ kJ/kg}\cdot^\circ\text{C}} \left(\frac{1 \text{ kJ/kg}}{1000 \text{ m}^2/\text{s}^2} \right) = \mathbf{159^\circ\text{C}}$$

$$P_{02} = P_2 \left(\frac{T_{02}}{T_2} \right)^{k/(k-1)} = (100 \text{ kPa}) \left(\frac{432.3 \text{ K}}{413.1 \text{ K}} \right)^{1.4/(1.4-1)} = \mathbf{117 \text{ kPa}}$$

Discussion Note that the stagnation temperature and pressure can be very different than their thermodynamic counterparts when dealing with compressible flow.

17-123 The mass flow parameter $\dot{m}\sqrt{RT_0}/(AP_0)$ versus the Mach number for $k = 1.2, 1.4,$ and 1.6 in the range of $0 \leq \text{Ma} \leq 1$ is to be plotted.

Analysis The mass flow rate parameter $(\dot{m}\sqrt{RT_0})/P_0A$ can be expressed as

$$\frac{\dot{m}\sqrt{RT_0}}{P_0A} = \text{Ma}\sqrt{k} \left(\frac{2}{2+(k-1)M^2} \right)^{(k+1)/2(k-1)}$$

Thus,

Ma	$k = 1.2$	$k = 1.4$	$k = 1.6$
0.0	0	0	0
0.1	0.1089	0.1176	0.1257
0.2	0.2143	0.2311	0.2465
0.3	0.3128	0.3365	0.3582
0.4	0.4015	0.4306	0.4571
0.5	0.4782	0.5111	0.5407
0.6	0.5411	0.5763	0.6077
0.7	0.5894	0.6257	0.6578
0.8	0.6230	0.6595	0.6916
0.9	0.6424	0.6787	0.7106
1.0	0.6485	0.6847	0.7164

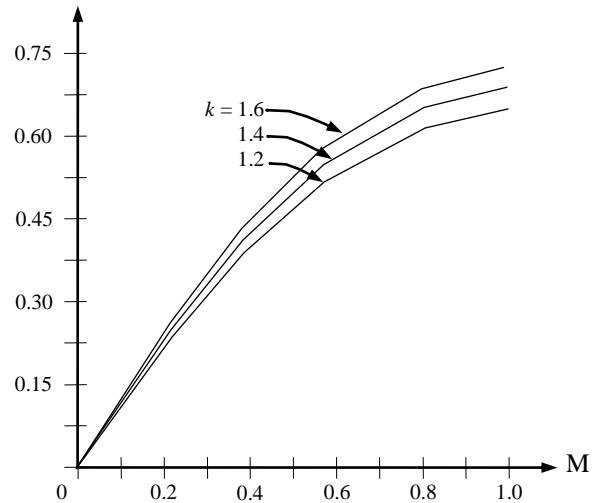

Discussion Note that the mass flow rate increases with increasing Mach number and specific heat ratio. It levels off at $\text{Ma} = 1$, and remains constant (choked flow).

17-124 The equivalent relation for the speed of sound is to be verified using thermodynamic relations.

Analysis The two relations are $c^2 = \left(\frac{\partial \mathcal{P}}{\partial \rho}\right)_s$ and $c^2 = k \left(\frac{\partial \mathcal{P}}{\partial \rho}\right)_T$

From $r = 1/\nu \longrightarrow dr = -d\nu/\nu^2$. Thus, $c^2 = \left(\frac{\partial \mathcal{P}}{\partial r}\right)_s = -\nu^2 \left(\frac{\partial \mathcal{P}}{\partial \nu}\right)_s = -\nu^2 \left(\frac{\partial \mathcal{P}}{\partial T} \frac{\partial T}{\partial \nu}\right)_s = -\nu^2 \left(\frac{\partial \mathcal{P}}{\partial T}\right)_s \left(\frac{\partial T}{\partial \nu}\right)_s$

From the cyclic rule,

$$(P, T, s): \left(\frac{\partial \mathcal{P}}{\partial T}\right)_s \left(\frac{\partial T}{\partial s}\right)_P \left(\frac{\partial s}{\partial \mathcal{P}}\right)_T = -1 \longrightarrow \left(\frac{\partial \mathcal{P}}{\partial T}\right)_s = -\left(\frac{\partial s}{\partial T}\right)_P \left(\frac{\partial \mathcal{P}}{\partial s}\right)_T$$

$$(T, \nu, s): \left(\frac{\partial T}{\partial \nu}\right)_s \left(\frac{\partial \nu}{\partial s}\right)_T \left(\frac{\partial s}{\partial T}\right)_\nu = -1 \longrightarrow \left(\frac{\partial T}{\partial \nu}\right)_s = -\left(\frac{\partial s}{\partial \nu}\right)_T \left(\frac{\partial T}{\partial s}\right)_\nu$$

Substituting,

$$c^2 = -\nu^2 \left(\frac{\partial s}{\partial T}\right)_P \left(\frac{\partial \mathcal{P}}{\partial s}\right)_T \left(\frac{\partial s}{\partial \nu}\right)_T \left(\frac{\partial T}{\partial s}\right)_\nu = -\nu^2 \left(\frac{\partial s}{\partial T}\right)_P \left(\frac{\partial T}{\partial s}\right)_\nu \left(\frac{\partial \mathcal{P}}{\partial \nu}\right)_T$$

Recall that $\frac{c_p}{T} = \left(\frac{\partial s}{\partial T}\right)_P$ and $\frac{c_v}{T} = \left(\frac{\partial s}{\partial T}\right)_\nu$. Substituting,

$$c^2 = -\nu^2 \left(\frac{c_p}{T}\right) \left(\frac{T}{c_v}\right) \left(\frac{\partial \mathcal{P}}{\partial \nu}\right)_T = -\nu^2 k \left(\frac{\partial \mathcal{P}}{\partial \nu}\right)_T$$

Replacing $-d\nu/\nu^2$ by $d\rho$, we get $c^2 = k \left(\frac{\partial \mathcal{P}}{\partial \rho}\right)_T$, which is the desired expression

Discussion Note that the differential thermodynamic property relations are very useful in the derivation of other property relations in differential form.

17-125 For ideal gases undergoing isentropic flows, expressions for P/P^* , T/T^* , and ρ/ρ^* as functions of k and Ma are to be obtained.

Analysis Equations 12-18 and 12-21 are given to be $\frac{T_0}{T} = \frac{2 + (k-1)\text{Ma}^2}{2}$ and $\frac{T^*}{T_0} = \frac{2}{k+1}$

Multiplying the two, $\left(\frac{T_0}{T} \frac{T^*}{T_0}\right) = \left(\frac{2 + (k-1)\text{Ma}^2}{2}\right) \left(\frac{2}{k+1}\right)$

Simplifying and inverting, $\frac{T}{T^*} = \frac{k+1}{2 + (k-1)\text{Ma}^2}$ (1)

From $\frac{P}{P^*} = \left(\frac{T}{T^*}\right)^{k/(k-1)} \longrightarrow \frac{P}{P^*} = \left(\frac{k+1}{2 + (k-1)\text{Ma}^2}\right)^{k/(k-1)}$ (2)

From $\frac{\rho}{\rho^*} = \left(\frac{P}{P^*}\right)^{k/(k-1)} \longrightarrow \frac{\rho}{\rho^*} = \left(\frac{k+1}{2 + (k-1)\text{Ma}^2}\right)^{k/(k-1)}$ (3)

Discussion Note that some very useful relations can be obtained by very simple manipulations.

17-126 It is to be verified that for the steady flow of ideal gases $dT_0/T = dA/A + (1-Ma^2) dV/V$. The effect of heating and area changes on the velocity of an ideal gas in steady flow for subsonic flow and supersonic flow are to be explained.

Analysis We start with the relation $\frac{V^2}{2} = c_p(T_0 - T)$ (1)

Differentiating, $VdV = c_p(dT_0 - dT)$ (2)

We also have $\frac{d\rho}{\rho} + \frac{dA}{A} + \frac{dV}{V} = 0$ (3)

and $\frac{dP}{\rho} + VdV = 0$ (4)

Differentiating the ideal gas relation $P = \rho RT$, $\frac{dP}{P} = \frac{d\rho}{\rho} + \frac{dT}{T} = 0$ (5)

From the speed of sound relation, $c^2 = kRT = (k-1)c_pT = kP/\rho$ (6)

Combining Eqs. (3) and (5), $\frac{dP}{P} - \frac{dT}{T} + \frac{dA}{A} + \frac{dV}{V} = 0$ (7)

Combining Eqs. (4) and (6), $\frac{dP}{\rho} = \frac{dP}{kP/c^2} = -VdV$

or, $\frac{dP}{P} = -\frac{k}{C^2} VdV = -k \frac{V^2}{C^2} \frac{dV}{V} = -kMa^2 \frac{dV}{V}$ (8)

Combining Eqs. (2) and (6), $dT = dT_0 - V \frac{dV}{c_p}$

or, $\frac{dT}{T} = \frac{dT_0}{T} - \frac{V^2}{C_p T} \frac{dV}{V} = \frac{dT}{T} = \frac{dT_0}{T} - \frac{V^2}{C^2/(k-1)} \frac{dV}{V} = \frac{dT_0}{T} - (k-1)Ma^2 \frac{dV}{V}$ (9)

Combining Eqs. (7), (8), and (9), $-(k-1)Ma^2 \frac{dV}{V} - \frac{dT_0}{T} + (k-1)Ma^2 \frac{dV}{V} + \frac{dA}{A} + \frac{dV}{V} = 0$

or, $\frac{dT_0}{T} = \frac{dA}{A} + [-kMa^2 + (k-1)Ma^2 + 1] \frac{dV}{V}$

Thus, $\boxed{\frac{dT_0}{T} = \frac{dA}{A} + (1-Ma^2) \frac{dV}{V}}$ (10)

Differentiating the steady-flow energy equation $q = h_{02} - h_{01} = c_p(T_{02} - T_{01})$

$$\delta q = c_p dT_0 \quad (11)$$

Eq. (11) relates the stagnation temperature change dT_0 to the net heat transferred to the fluid. Eq. (10) relates the velocity changes to area changes dA , and the stagnation temperature change dT_0 or the heat transferred.

(a) When $Ma < 1$ (subsonic flow), **the fluid accelerates if the duct converges ($dA < 0$) or the fluid is heated ($dT_0 > 0$ or $\delta q > 0$). The fluid decelerates if the duct diverges ($dA > 0$) or the fluid is cooled ($dT_0 < 0$ or $\delta q < 0$).**

(b) When $Ma > 1$ (supersonic flow), **the fluid accelerates if the duct diverges ($dA > 0$) or the fluid is cooled ($dT_0 < 0$ or $\delta q < 0$). The fluid decelerates if the duct converges ($dA < 0$) or the fluid is heated ($dT_0 > 0$ or $\delta q > 0$).**

Discussion Some of these results are not intuitively obvious, but come about by satisfying the conservation equations.

17-127 A Pitot-static probe measures the difference between the static and stagnation pressures for a subsonic airplane. The speed of the airplane and the flight Mach number are to be determined.

Assumptions **1** Air is an ideal gas with a constant specific heat ratio. **2** The stagnation process is isentropic.

Properties The properties of air are $R = 0.287 \text{ kJ/kg}\cdot\text{K}$ and $k = 1.4$.

Analysis The stagnation pressure of air at the specified conditions is

$$P_0 = P + \Delta P = 54 + 16 = 70 \text{ kPa}$$

Then,

$$\frac{P_0}{P} = \left(1 + \frac{(k-1)\text{Ma}^2}{2}\right)^{k/k-1} \longrightarrow \frac{70}{54} = \left(1 + \frac{(1.4-1)\text{Ma}^2}{2}\right)^{1.4/0.4}$$

It yields

$$\mathbf{Ma = 0.620}$$

The speed of sound in air at the specified conditions is

$$c = \sqrt{kRT} = \sqrt{(1.4)(0.287 \text{ kJ/kg}\cdot\text{K})(256 \text{ K})\left(\frac{1000 \text{ m}^2/\text{s}^2}{1 \text{ kJ/kg}}\right)} = 320.7 \text{ m/s}$$

Thus,

$$V = \text{Ma} \times c = (0.620)(320.7 \text{ m/s}) = \mathbf{199 \text{ m/s}}$$

Discussion Note that the flow velocity can be measured in a simple and accurate way by simply measuring pressure.

17-128 An expression for the speed of sound based on van der Waals equation of state is to be derived. Using this relation, the speed of sound in carbon dioxide is to be determined and compared to that obtained by ideal gas behavior.

Properties The properties of CO₂ are $R = 0.1889 \text{ kJ/kg}\cdot\text{K}$ and $k = 1.279$ at $T = 50^\circ\text{C} = 323.2 \text{ K}$.

Analysis Van der Waals equation of state can be expressed as $P = \frac{RT}{v-b} - \frac{a}{v^2}$.

Differentiating,
$$\left(\frac{\partial P}{\partial v}\right)_T = \frac{RT}{(v-b)^2} + \frac{2a}{v^3}$$

Noting that $\rho = 1/v \longrightarrow d\rho = -dv/v^2$, the speed of sound relation becomes

Substituting,
$$c^2 = k\left(\frac{\partial P}{\partial v}\right)_T = v^2 k\left(\frac{\partial P}{\partial v}\right)_T$$

$$c^2 = \frac{v^2 kRT}{(v-b)^2} - \frac{2ak}{v}$$

Using the molar mass of CO₂ ($M = 44 \text{ kg/kmol}$), the constant a and b can be expressed per unit mass as

$$a = 0.1882 \text{ kPa}\cdot\text{m}^6/\text{kg}^2 \quad \text{and} \quad b = 9.70 \times 10^{-4} \text{ m}^3/\text{kg}$$

The specific volume of CO₂ is determined to be

$$200 \text{ kPa} = \frac{(0.1889 \text{ kPa}\cdot\text{m}^3/\text{kg}\cdot\text{K})(323.2 \text{ K})}{v - 0.000970 \text{ m}^3/\text{kg}} - \frac{2 \times 0.1882 \text{ kPa}\cdot\text{m}^6/\text{kg}^2}{v^2} \rightarrow v = 0.300 \text{ m}^3/\text{kg}$$

Substituting,

$$c = \left(\left(\frac{(0.300 \text{ m}^3/\text{kg})^2 (1.279)(0.1889 \text{ kJ/kg}\cdot\text{K})(323.2 \text{ K})}{(0.300 - 0.000970 \text{ m}^3/\text{kg})^2} - \frac{2(0.1882 \text{ kPa}\cdot\text{m}^6/\text{kg}^3)(1.279)}{(0.300 \text{ m}^3/\text{kg})^2} \right) \left(\frac{1000 \text{ m}^2/\text{s}^2}{1 \text{ kPa}\cdot\text{m}^3/\text{kg}} \right) \right)^{1/2}$$

$$= \mathbf{271 \text{ m/s}}$$

If we treat CO₂ as an ideal gas, the speed of sound becomes

$$c = \sqrt{kRT} = \sqrt{(1.279)(0.1889 \text{ kJ/kg}\cdot\text{K})(323.2 \text{ K}) \left(\frac{1000 \text{ m}^2/\text{s}^2}{1 \text{ kJ/kg}} \right)} = \mathbf{279 \text{ m/s}}$$

Discussion Note that the ideal gas relation is the simplest equation of state, and it is very accurate for most gases encountered in practice. At high pressures and/or low temperatures, however, the gases deviate from ideal gas behavior, and it becomes necessary to use more complicated equations of state.

17-129 Helium gas is accelerated in a nozzle. The pressure and temperature of helium at the location where $Ma = 1$ and the ratio of the flow area at this location to the inlet flow area are to be determined.

Assumptions **1** Helium is an ideal gas with constant specific heats. **2** Flow through the nozzle is steady, one-dimensional, and isentropic.

Properties The properties of helium are $R = 2.0769 \text{ kJ/kg}\cdot\text{K}$, $c_p = 5.1926 \text{ kJ/kg}\cdot\text{K}$, and $k = 1.667$.

Analysis The properties of the fluid at the location where $Ma = 1$ are the critical properties, denoted by superscript *. We first determine the stagnation temperature and pressure, which remain constant throughout the nozzle since the flow is isentropic.

$$T_0 = T_i + \frac{V_i^2}{2c_p} = 560 \text{ K} + \frac{(120 \text{ m/s})^2}{2 \times 5.1926 \text{ kJ/kg}\cdot\text{K}} \left(\frac{1 \text{ kJ/kg}}{1000 \text{ m}^2/\text{s}^2} \right) = 561.4 \text{ K}$$

and

$$P_0 = P_i \left(\frac{T_0}{T_i} \right)^{k/(k-1)} = (0.6 \text{ MPa}) \left(\frac{561.4 \text{ K}}{560 \text{ K}} \right)^{1.667/(1.667-1)} = 0.6037 \text{ MPa}$$

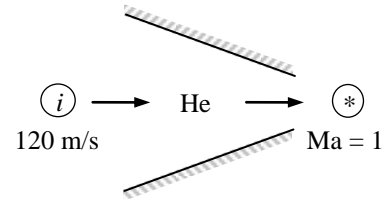

The Mach number at the nozzle exit is given to be $Ma = 1$. Therefore, the properties at the nozzle exit are the *critical properties* determined from

$$T^* = T_0 \left(\frac{2}{k+1} \right) = (561.4 \text{ K}) \left(\frac{2}{1.667+1} \right) = 421.0 \text{ K} = \mathbf{421 \text{ K}}$$

$$P^* = P_0 \left(\frac{2}{k+1} \right)^{k/(k-1)} = (0.6037 \text{ MPa}) \left(\frac{2}{1.667+1} \right)^{1.667/(1.667-1)} = 0.2941 \text{ MPa} \cong \mathbf{0.294 \text{ MPa}}$$

The speed of sound and the Mach number at the nozzle inlet are

$$c_i = \sqrt{kRT_i} = \sqrt{(1.667)(2.0769 \text{ kJ/kg}\cdot\text{K})(560 \text{ K}) \left(\frac{1000 \text{ m}^2/\text{s}^2}{1 \text{ kJ/kg}} \right)} = 1392 \text{ m/s}$$

$$Ma_i = \frac{V_i}{c_i} = \frac{120 \text{ m/s}}{1392 \text{ m/s}} = 0.08618$$

The ratio of the entrance-to-throat area is

$$\begin{aligned} \frac{A_i}{A^*} &= \frac{1}{Ma_i} \left[\left(\frac{2}{k+1} \right) \left(1 + \frac{k-1}{2} Ma_i^2 \right) \right]^{(k+1)/(2(k-1))} \\ &= \frac{1}{0.08618} \left[\left(\frac{2}{1.667+1} \right) \left(1 + \frac{1.667-1}{2} (0.08618)^2 \right) \right]^{2.667/(2 \times 0.667)} \\ &= 8.745 \end{aligned}$$

Then the ratio of the throat area to the entrance area becomes

$$\frac{A^*}{A_i} = \frac{1}{8.745} = 0.1144 \cong \mathbf{0.114}$$

Discussion The compressible flow functions are essential tools when determining the proper shape of the compressible flow duct.

17-130 Helium gas enters a nozzle with negligible velocity, and is accelerated in a nozzle. The pressure and temperature of helium at the location where $Ma = 1$ and the ratio of the flow area at this location to the inlet flow area are to be determined.

Assumptions **1** Helium is an ideal gas with constant specific heats. **2** Flow through the nozzle is steady, one-dimensional, and isentropic. **3** The entrance velocity is negligible.

Properties The properties of helium are $R = 2.0769 \text{ kJ/kg}\cdot\text{K}$, $c_p = 5.1926 \text{ kJ/kg}\cdot\text{K}$, and $k = 1.667$.

Analysis We treat helium as an ideal gas with $k = 1.667$. The properties of the fluid at the location where $Ma = 1$ are the critical properties, denoted by superscript $*$.

The stagnation temperature and pressure in this case are identical to the inlet temperature and pressure since the inlet velocity is negligible. They remain constant throughout the nozzle since the flow is isentropic.

$$T_0 = T_i = 560 \text{ K}$$

$$P_0 = P_i = 0.6 \text{ MPa}$$

The Mach number at the nozzle exit is given to be $Ma = 1$. Therefore, the properties at the nozzle exit are the *critical properties* determined from

$$T^* = T_0 \left(\frac{2}{k+1} \right) = (560 \text{ K}) \left(\frac{2}{1.667+1} \right) = \mathbf{420 \text{ K}}$$

$$P^* = P_0 \left(\frac{2}{k+1} \right)^{k/(k-1)} = (0.6 \text{ MPa}) \left(\frac{2}{1.667+1} \right)^{1.667/(1.667-1)} = \mathbf{0.292 \text{ MPa}}$$

The ratio of the nozzle inlet area to the throat area is determined from

$$\frac{A_i}{A^*} = \frac{1}{Ma_i} \left[\left(\frac{2}{k+1} \right) \left(1 + \frac{k-1}{2} Ma_i^2 \right) \right]^{(k+1)/[2(k-1)]}$$

But the Mach number at the nozzle inlet is $Ma = 0$ since $V_i \cong 0$. Thus the ratio of the throat area to the nozzle inlet area is

$$\frac{A^*}{A_i} = \frac{1}{\infty} = \mathbf{0}$$

Discussion The compressible flow functions are essential tools when determining the proper shape of the compressible flow duct.

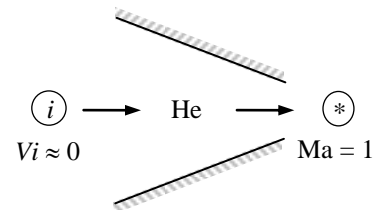



17-131 Air enters a converging nozzle. The mass flow rate, the exit velocity, the exit Mach number, and the exit pressure-stagnation pressure ratio versus the back pressure-stagnation pressure ratio for a specified back pressure range are to be calculated and plotted.

Assumptions **1** Air is an ideal gas with constant specific heats at room temperature. **2** Flow through the nozzle is steady, one-dimensional, and isentropic.

Properties The properties of air at room temperature are $R = 0.287 \text{ kJ/kg}\cdot\text{K}$, $c_p = 1.005 \text{ kJ/kg}\cdot\text{K}$, and $k = 1.4$.

Analysis We use EES to tabulate and plot the results. The stagnation properties remain constant throughout the nozzle since the flow is isentropic. They are determined from

$$T_0 = T_i + \frac{V_i^2}{2c_p} = 400 \text{ K} + \frac{(180 \text{ m/s})^2}{2 \times 1.005 \text{ kJ/kg}\cdot\text{K}} \left(\frac{1 \text{ kJ/kg}}{1000 \text{ m}^2/\text{s}^2} \right) = 416.1 \text{ K}$$

$$P_0 = P_i \left(\frac{T_0}{T_i} \right)^{k/(k-1)} = (900 \text{ kPa}) \left(\frac{416.1 \text{ K}}{400 \text{ K}} \right)^{1.4/(1.4-1)} = 1033.3 \text{ kPa}$$

The critical pressure is determined to be

$$P^* = P_0 \left(\frac{2}{k+1} \right)^{k/(k-1)} = (1033.3 \text{ kPa}) \left(\frac{2}{1.4+1} \right)^{1.4/0.4} = 545.9 \text{ kPa}$$

Then the pressure at the exit plane (throat) is

$$P_e = P_b \quad \text{for } P_b \geq 545.9 \text{ kPa}$$

$$P_e = P^* = 545.9 \text{ kPa} \quad \text{for } P_b < 545.9 \text{ kPa} \text{ (choked flow)}$$

Thus the back pressure does not affect the flow when $100 < P_b < 545.9 \text{ kPa}$. For a specified exit pressure P_e , the temperature, velocity, and mass flow rate are

$$\text{Temperature} \quad T_e = T_0 \left(\frac{P_e}{P_0} \right)^{(k-1)/k} = (416.1 \text{ K}) \left(\frac{P_e}{1033.3} \right)^{0.4/1.4}$$

$$\text{Velocity } V = \sqrt{2c_p(T_0 - T_e)} = \sqrt{2(1.005 \text{ kJ/kg}\cdot\text{K})(416.1 - T_e) \left(\frac{1000 \text{ m}^2/\text{s}^2}{1 \text{ kJ/kg}} \right)}$$

$$\text{Speed of sound} \quad c_e = \sqrt{kRT_e} = \sqrt{(1.4)(0.287 \text{ kJ/kg}\cdot\text{K}) \left(\frac{1000 \text{ m}^2/\text{s}^2}{1 \text{ kJ/kg}} \right)}$$

$$\text{Mach number} \quad \text{Ma}_e = V_e / c_e$$

$$\text{Density} \quad \rho_e = \frac{P_e}{RT_e} = \frac{P_e}{(0.287 \text{ kPa}\cdot\text{m}^3/\text{kg}\cdot\text{K})T_e}$$

$$\text{Mass flow rate} \quad \dot{m} = \rho_e V_e A_e = \rho_e V_e (0.001 \text{ m}^2)$$

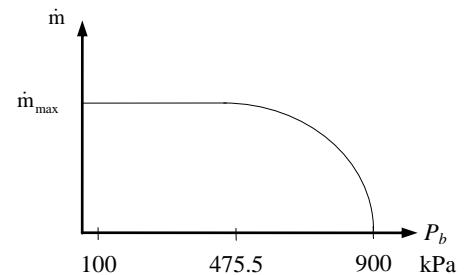
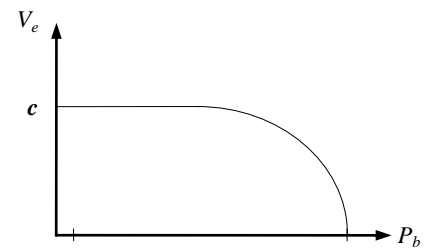
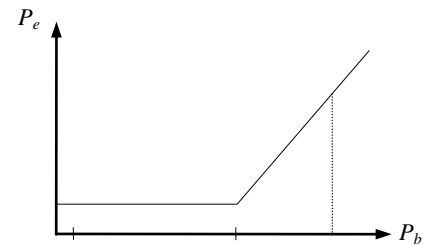
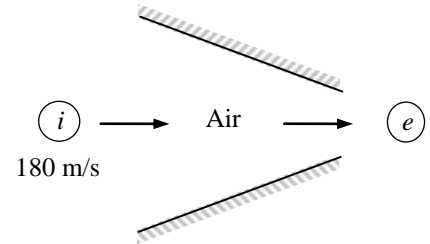

$P_b, \text{ kPa}$	P_b, P_0	$P_e, \text{ kPa}$	P_b, P_0	$T_e, \text{ K}$	$V_e, \text{ m/s}$	Ma	$\rho_e, \text{ kg/m}^3$	$\dot{m}, \text{ kg/s}$
900	0.871	900	0.871	400.0	180.0	0.45	7.840	0
800	0.774	800	0.774	386.8	162.9	0.41	7.206	1.174
700	0.677	700	0.677	372.3	236.0	0.61	6.551	1.546
600	0.581	600	0.581	356.2	296.7	0.78	5.869	1.741
545.9	0.528	545.9	0.528	333.3	366.2	1.00	4.971	1.820
500	0.484	545.9	0.528	333.2	366.2	1.00	4.971	1.820
400	0.387	545.9	0.528	333.3	366.2	1.00	4.971	1.820
300	0.290	545.9	0.528	333.3	366.2	1.00	4.971	1.820
200	0.194	545.9	0.528	333.3	366.2	1.00	4.971	1.820
100	0.097	545.9	0.528	333.3	366.2	1.00	4.971	1.820

Discussion Once the back pressure drops below 545.0 kPa, the flow is choked, and \dot{m} remains constant from then on.

17-132 Nitrogen gas enters a converging nozzle. The properties at the nozzle exit are to be determined.

Assumptions 1 Nitrogen is an ideal gas with $k = 1.4$. 2 Flow through the nozzle is steady, one-dimensional, and isentropic.

Analysis The schematic of the duct is shown in Fig. 12–25. For isentropic flow through a duct, the area ratio A/A^* (the flow area over the area of the throat where $Ma = 1$) is also listed in Table A–32. At the initial Mach number of $Ma = 0.3$, we read

$$\frac{A_1}{A^*} = 2.0351, \quad \frac{T_1}{T_0} = 0.9823, \quad \text{and} \quad \frac{P_1}{P_0} = 0.9395$$

With a 20 percent reduction in flow area, $A_2 = 0.8A_1$, and

$$\frac{A_2}{A^*} = \frac{A_2}{A_1} \frac{A_1}{A^*} = (0.8)(2.0351) = 1.6281$$

For this value of A_2/A^* from Table A–32, we read

$$\frac{T_2}{T_0} = 0.9791, \quad \frac{P_2}{P_0} = 0.8993, \quad \text{and} \quad Ma_2 = \mathbf{0.391}$$

Here we chose the subsonic Mach number for the calculated A_2/A^* instead of the supersonic one because the duct is converging in the flow direction and the initial flow is subsonic. Since the stagnation properties are constant for isentropic flow, we can write

$$\frac{T_2}{T_1} = \frac{T_2/T_0}{T_1/T_0} \quad \rightarrow \quad T_2 = T_1 \left(\frac{T_2/T_0}{T_1/T_0} \right) = (400 \text{ K}) \left(\frac{0.9791}{0.9823} \right) = \mathbf{399 \text{ K}}$$

$$\frac{P_2}{P_1} = \frac{P_2/P_0}{P_1/P_0} \quad \rightarrow \quad P_2 = P_1 \left(\frac{P_2/P_0}{P_1/P_0} \right) = (100 \text{ kPa}) \left(\frac{0.8993}{0.9395} \right) = \mathbf{95.7 \text{ K}}$$

which are the temperature and pressure at the desired location.

Discussion Note that the temperature and pressure drop as the fluid accelerates in a converging nozzle.

17-133 Nitrogen gas enters a converging nozzle. The properties at the nozzle exit are to be determined.

Assumptions 1 Nitrogen is an ideal gas with $k = 1.4$. 2 Flow through the nozzle is steady, one-dimensional, and isentropic.

Analysis The schematic of the duct is shown in Fig. 12–25. For isentropic flow through a duct, the area ratio A/A^* (the flow area over the area of the throat where $\text{Ma} = 1$) is also listed in Table A–32. At the initial Mach number of $\text{Ma} = 0.5$, we read

$$\frac{A_1}{A^*} = 1.3398, \quad \frac{T_1}{T_0} = 0.9524, \quad \text{and} \quad \frac{P_1}{P_0} = 0.8430$$

With a 20 percent reduction in flow area, $A_2 = 0.8A_1$, and

$$\frac{A_2}{A^*} = \frac{A_2}{A_1} \frac{A_1}{A^*} = (0.8)(1.3398) = 1.0718$$

For this value of A_2/A^* from Table A–32, we read

$$\frac{T_2}{T_0} = 0.9010, \quad \frac{P_2}{P_0} = 0.6948, \quad \text{and} \quad \text{Ma}_2 = \mathbf{0.740}$$

Here we chose the subsonic Mach number for the calculated A_2/A^* instead of the supersonic one because the duct is converging in the flow direction and the initial flow is subsonic. Since the stagnation properties are constant for isentropic flow, we can write

$$\frac{T_2}{T_1} = \frac{T_2/T_0}{T_1/T_0} \quad \rightarrow \quad T_2 = T_1 \left(\frac{T_2/T_0}{T_1/T_0} \right) = (400 \text{ K}) \left(\frac{0.9010}{0.9524} \right) = \mathbf{378 \text{ K}}$$

$$\frac{P_2}{P_1} = \frac{P_2/P_0}{P_1/P_0} \quad \rightarrow \quad P_2 = P_1 \left(\frac{P_2/P_0}{P_1/P_0} \right) = (100 \text{ kPa}) \left(\frac{0.6948}{0.8430} \right) = \mathbf{82.4 \text{ K}}$$

which are the temperature and pressure at the desired location.

Discussion Note that the temperature and pressure drop as the fluid accelerates in a converging nozzle.

17-134 Nitrogen entering a converging-diverging nozzle experiences a normal shock. The pressure, temperature, velocity, Mach number, and stagnation pressure downstream of the shock are to be determined. The results are to be compared to those of air under the same conditions.

Assumptions **1** Nitrogen is an ideal gas with constant specific heats. **2** Flow through the nozzle is steady, one-dimensional, and isentropic. **3** The nozzle is adiabatic.

Properties The properties of nitrogen are $R = 0.297 \text{ kJ/kg}\cdot\text{K}$ and $k = 1.4$.

Analysis The inlet stagnation properties in this case are identical to the inlet properties since the inlet velocity is negligible. Assuming the flow before the shock to be isentropic,

$$P_{01} = P_i = 620 \text{ kPa}$$

$$T_{01} = T_i = 310 \text{ K}$$

Then,

$$T_1 = T_{01} \left(\frac{2}{2 + (k-1)\text{Ma}_1^2} \right) = (310 \text{ K}) \left(\frac{2}{2 + (1.4-1)3^2} \right) = 110.7 \text{ K}$$

and

$$P_1 = P_{01} \left(\frac{T_1}{T_{01}} \right)^{k/(k-1)} = (620 \text{ kPa}) \left(\frac{110.7}{310} \right)^{1.4/0.4} = 16.88 \text{ kPa}$$

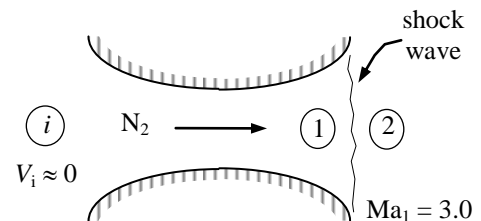

The fluid properties after the shock (denoted by subscript 2) are related to those before the shock through the functions listed in Table A-33. For $\text{Ma}_1 = 3.0$ we read

$$\text{Ma}_2 = 0.4752 \cong \mathbf{0.475}, \quad \frac{P_{02}}{P_{01}} = 0.32834, \quad \frac{P_2}{P_1} = 10.333, \quad \text{and} \quad \frac{T_2}{T_1} = 2.679$$

Then the stagnation pressure P_{02} , static pressure P_2 , and static temperature T_2 , are determined to be

$$P_{02} = 0.32834 P_{01} = (0.32834)(620 \text{ kPa}) = 203.6 \text{ kPa} \cong \mathbf{204 \text{ kPa}}$$

$$P_2 = 10.333 P_1 = (10.333)(16.88 \text{ kPa}) = 174.4 \text{ kPa} \cong \mathbf{174 \text{ kPa}}$$

$$T_2 = 2.679 T_1 = (2.679)(110.7 \text{ K}) = 296.6 \text{ K} \cong \mathbf{297 \text{ K}}$$

The velocity after the shock can be determined from $V_2 = \text{Ma}_2 c_2$, where c_2 is the speed of sound at the exit conditions after the shock,

$$V_2 = \text{Ma}_2 c_2 = \text{Ma}_2 \sqrt{kRT_2} = (0.4752) \sqrt{(1.4)(0.297 \text{ kJ/kg}\cdot\text{K})(296.6 \text{ K}) \left(\frac{1000 \text{ m}^2/\text{s}^2}{1 \text{ kJ/kg}} \right)} = 166.9 \text{ m/s} \cong \mathbf{167 \text{ m/s}}$$

Discussion For *air* at specified conditions $k = 1.4$ (same as nitrogen) and $R = 0.287 \text{ kJ/kg}\cdot\text{K}$. Thus the only quantity which will be different in the case of air is the velocity after the normal shock, which happens to be 164.0 m/s.

17-135 The diffuser of an aircraft is considered. The static pressure rise across the diffuser and the exit area are to be determined.

Assumptions 1 Air is an ideal gas with constant specific heats at room temperature. 2 Flow through the diffuser is steady, one-dimensional, and isentropic. 3 The diffuser is adiabatic.

Properties Air properties at room temperature are $R = 0.287 \text{ kJ/kg}\cdot\text{K}$, $c_p = 1.005 \text{ kJ/kg}\cdot\text{K}$, and $k = 1.4$.

Analysis The inlet velocity is

$$V_1 = \text{Ma}_1 c_1 = M_1 \sqrt{kRT_1} = (0.9) \sqrt{(1.4)(0.287 \text{ kJ/kg}\cdot\text{K})(242.7 \text{ K}) \left(\frac{1000 \text{ m}^2/\text{s}^2}{1 \text{ kJ/kg}} \right)} = 281.0 \text{ m/s}$$

Then the stagnation temperature and pressure at the diffuser inlet become

$$T_{01} = T_1 + \frac{V_1^2}{2c_p} = 242.7 + \frac{(281.0 \text{ m/s})^2}{2(1.005 \text{ kJ/kg}\cdot\text{K}) \left(\frac{1 \text{ kJ/kg}}{1000 \text{ m}^2/\text{s}^2} \right)} = 282.0 \text{ K}$$

$$P_{01} = P_1 \left(\frac{T_{01}}{T_1} \right)^{k/(k-1)} = (41.1 \text{ kPa}) \left(\frac{282.0 \text{ K}}{242.7 \text{ K}} \right)^{1.4/(1.4-1)} = 69.50 \text{ kPa}$$

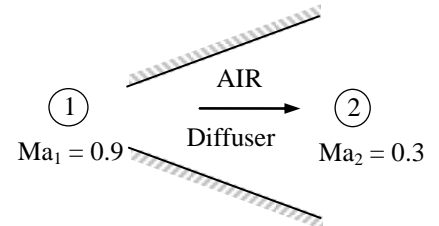

For an adiabatic diffuser, the energy equation reduces to $h_{01} = h_{02}$. Noting that $h = c_p T$ and the specific heats are assumed to be constant, we have

$$T_{01} = T_{02} = T_0 = 282.0 \text{ K}$$

The isentropic relation between states 1 and 02 gives

$$P_{02} = P_{01} = P_1 \left(\frac{T_{02}}{T_1} \right)^{k/(k-1)} = (41.1 \text{ kPa}) \left(\frac{282.0 \text{ K}}{242.7 \text{ K}} \right)^{1.4/(1.4-1)} = 69.50 \text{ kPa}$$

The exit velocity can be expressed as

$$V_2 = \text{Ma}_2 c_2 = \text{Ma}_2 \sqrt{kRT_2} = (0.3) \sqrt{(1.4)(0.287 \text{ kJ/kg}\cdot\text{K}) T_2 \left(\frac{1000 \text{ m}^2/\text{s}^2}{1 \text{ kJ/kg}} \right)} = 6.01 \sqrt{T_2}$$

$$\text{Thus } T_2 = T_{02} - \frac{V_2^2}{2c_p} = (282.0) - \frac{6.01^2 T_2 \text{ m}^2/\text{s}^2}{2(1.005 \text{ kJ/kg}\cdot\text{K}) \left(\frac{1 \text{ kJ/kg}}{1000 \text{ m}^2/\text{s}^2} \right)} = 277.0 \text{ K}$$

Then the static exit pressure becomes

$$P_2 = P_{02} \left(\frac{T_2}{T_{02}} \right)^{k/(k-1)} = (69.50 \text{ kPa}) \left(\frac{277.0 \text{ K}}{282.0 \text{ K}} \right)^{1.4/(1.4-1)} = 65.28 \text{ kPa}$$

Thus the static pressure rise across the diffuser is

$$\Delta P = P_2 - P_1 = 65.28 - 41.1 = \mathbf{24.2 \text{ kPa}}$$

$$\text{Also, } \rho_2 = \frac{P_2}{RT_2} = \frac{65.28 \text{ kPa}}{(0.287 \text{ kPa}\cdot\text{m}^3/\text{kg}\cdot\text{K})(277.0 \text{ K})} = 0.8211 \text{ kg/m}^3$$

$$V_2 = 6.01 \sqrt{T_2} = 6.01 \sqrt{277.0} = 100.0 \text{ m/s}$$

$$\text{Thus } A_2 = \frac{\dot{m}}{\rho_2 V_2} = \frac{38 \text{ kg/s}}{(0.8211 \text{ kg/m}^3)(100.0 \text{ m/s})} = \mathbf{0.463 \text{ m}^2}$$

Discussion The pressure rise in actual diffusers will be lower because of the irreversibilities. However, flow through well-designed diffusers is very nearly isentropic.

17-136 The critical temperature, pressure, and density of an equimolar mixture of oxygen and nitrogen for specified stagnation properties are to be determined.

Assumptions Both oxygen and nitrogen are ideal gases with constant specific heats at room temperature.

Properties The specific heat ratio and molar mass are $k = 1.395$ and $M = 32$ kg/kmol for oxygen, and $k = 1.4$ and $M = 28$ kg/kmol for nitrogen.

Analysis The gas constant of the mixture is

$$M_m = y_{O_2} M_{O_2} + y_{N_2} M_{N_2} = 0.5 \times 32 + 0.5 \times 28 = 30 \text{ kg/kmol}$$

$$R_m = \frac{R_u}{M_m} = \frac{8.314 \text{ kJ/kmol} \cdot \text{K}}{30 \text{ kg/kmol}} = 0.2771 \text{ kJ/kg} \cdot \text{K}$$

The specific heat ratio is 1.4 for nitrogen, and nearly 1.4 for oxygen. Therefore, the specific heat ratio of the mixture is also 1.4. Then the critical temperature, pressure, and density of the mixture become

$$T^* = T_0 \left(\frac{2}{k+1} \right) = (550 \text{ K}) \left(\frac{2}{1.4+1} \right) = 458.3 \text{ K} \cong \mathbf{458 \text{ K}}$$

$$P^* = P_0 \left(\frac{2}{k+1} \right)^{k/(k-1)} = (350 \text{ kPa}) \left(\frac{2}{1.4+1} \right)^{1.4/(1.4-1)} = 184.9 \text{ kPa} \cong \mathbf{185 \text{ kPa}}$$

$$\rho^* = \frac{P^*}{RT^*} = \frac{184.9 \text{ kPa}}{(0.2771 \text{ kPa} \cdot \text{m}^3/\text{kg} \cdot \text{K})(458.3 \text{ K})} = \mathbf{1.46 \text{ kg/m}^3}$$

Discussion If the specific heat ratios k of the two gases were different, then we would need to determine the k of the mixture from $k = c_{p,m}/c_{v,m}$ where the specific heats of the mixture are determined from

$$C_{p,m} = mf_{O_2} c_{p,O_2} + mf_{N_2} c_{p,N_2} = (y_{O_2} M_{O_2} / M_m) c_{p,O_2} + (y_{N_2} M_{N_2} / M_m) c_{p,N_2}$$

$$C_{v,m} = mf_{O_2} c_{v,O_2} + mf_{N_2} c_{v,N_2} = (y_{O_2} M_{O_2} / M_m) c_{v,O_2} + (y_{N_2} M_{N_2} / M_m) c_{v,N_2}$$

where mf is the mass fraction and y is the mole fraction. In this case it would give

$$c_{p,m} = (0.5 \times 32 / 30) \times 0.918 + (0.5 \times 28 / 30) \times 1.039 = 0.974 \text{ kJ/kg} \cdot \text{K}$$

$$c_{v,m} = (0.5 \times 32 / 30) \times 0.658 + (0.5 \times 28 / 30) \times 0.743 = 0.698 \text{ kJ/kg} \cdot \text{K}$$

and

$$k = 0.974 / 0.698 = 1.40$$

17-137E Helium gas is accelerated in a nozzle. For a specified mass flow rate, the throat and exit areas of the nozzle are to be determined for the case of isentropic nozzle.

Assumptions **1** Helium is an ideal gas with constant specific heats. **2** Flow through the nozzle is steady, one-dimensional, and isentropic. **3** The nozzle is adiabatic.

Properties The properties of helium are $R = 0.4961 \text{ Btu/lbm}\cdot\text{R} = 2.6809 \text{ psia}\cdot\text{ft}^3/\text{lbm}\cdot\text{R}$, $c_p = 1.25 \text{ Btu/lbm}\cdot\text{R}$, and $k = 1.667$.

Analysis The inlet stagnation properties in this case are identical to the inlet properties since the inlet velocity is negligible,

$$T_{01} = T_1 = 740 \text{ R}$$

$$P_{01} = P_1 = 220 \text{ psia}$$

The flow is assumed to be isentropic, thus the stagnation temperature and pressure remain constant throughout the nozzle,

$$T_{02} = T_{01} = 740 \text{ R}$$

$$P_{02} = P_{01} = 220 \text{ psia}$$

The critical pressure and temperature are determined from

$$T^* = T_0 \left(\frac{2}{k+1} \right) = (740 \text{ R}) \left(\frac{2}{1.667+1} \right) = 554.9 \text{ R}$$

$$P^* = P_0 \left(\frac{2}{k+1} \right)^{k/(k-1)} = (220 \text{ psia}) \left(\frac{2}{1.667+1} \right)^{1.667/(1.667-1)} = 107.2 \text{ psia}$$

$$\rho^* = \frac{P^*}{RT^*} = \frac{107.2 \text{ psia}}{(2.6809 \text{ psia}\cdot\text{ft}^3/\text{lbm}\cdot\text{R})(554.9 \text{ R})} = 0.07203 \text{ lbm/ft}^3$$

$$V^* = c^* = \sqrt{kRT^*} = \sqrt{(1.667)(0.4961 \text{ Btu/lbm}\cdot\text{R})(554.9 \text{ R}) \left(\frac{25,037 \text{ ft}^2/\text{s}^2}{1 \text{ Btu/lbm}} \right)} = 3390 \text{ ft/s}$$

and
$$A^* = \frac{\dot{m}}{\rho^* V^*} = \frac{0.2 \text{ lbm/s}}{(0.07203 \text{ lbm/ft}^3)(3390 \text{ ft/s})} = \mathbf{8.19 \times 10^{-4} \text{ ft}^2}$$

At the nozzle exit the pressure is $P_2 = 15 \text{ psia}$. Then the other properties at the nozzle exit are determined to be

$$\frac{P_0}{P_2} = \left(1 + \frac{k-1}{2} \text{Ma}_2^2 \right)^{k/(k-1)} \longrightarrow \frac{220 \text{ psia}}{15 \text{ psia}} = \left(1 + \frac{1.667-1}{2} \text{Ma}_2^2 \right)^{1.667/0.667}$$

It yields $\text{Ma}_2 = 2.405$, which is greater than 1. Therefore, the nozzle must be converging-diverging.

$$T_2 = T_0 \left(\frac{2}{2 + (k-1)\text{Ma}_2^2} \right) = (740 \text{ R}) \left(\frac{2}{2 + (1.667-1) \times 2.405^2} \right) = 252.6 \text{ R}$$

$$\rho_2 = \frac{P_2}{RT_2} = \frac{15 \text{ psia}}{(2.6809 \text{ psia}\cdot\text{ft}^3/\text{lbm}\cdot\text{R})(252.6 \text{ R})} = 0.02215 \text{ lbm/ft}^3$$

$$V_2 = \text{Ma}_2 c_2 = \text{Ma}_2 \sqrt{kRT_2} = (2.405) \sqrt{(1.667)(0.4961 \text{ Btu/lbm}\cdot\text{R})(252.6 \text{ R}) \left(\frac{25,037 \text{ ft}^2/\text{s}^2}{1 \text{ Btu/lbm}} \right)} = 5500 \text{ ft/s}$$

Thus the exit area is

$$A_2 = \frac{\dot{m}}{\rho_2 V_2} = \frac{0.2 \text{ lbm/s}}{(0.02215 \text{ lbm/ft}^3)(5500 \text{ ft/s})} = \mathbf{0.00164 \text{ ft}^2}$$

Discussion Flow areas in actual nozzles would be somewhat larger to accommodate the irreversibilities.

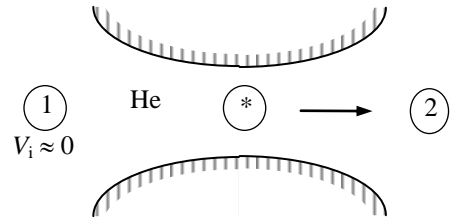



17-138 Using the compressible flow relations, the one-dimensional compressible flow functions are to be evaluated and tabulated as in Table A-32 for an ideal gas with $k = 1.667$.

Properties The specific heat ratio of the ideal gas is given to be $k = 1.667$.

Analysis The compressible flow functions listed below are expressed in EES and the results are tabulated.

$$\text{Ma}^* = \text{Ma} \sqrt{\frac{k+1}{2+(k-1)\text{Ma}^2}} \quad \frac{A}{A^*} = \frac{1}{\text{Ma}} \left[\left(\frac{2}{k+1} \right) \left(1 + \frac{k-1}{2} \text{Ma}^2 \right) \right]^{0.5(k+1)/(k-1)}$$

$$\frac{P}{P_0} = \left(1 + \frac{k-1}{2} \text{Ma}^2 \right)^{-k/(k-1)} \quad \frac{\rho}{\rho_0} = \left(1 + \frac{k-1}{2} \text{Ma}^2 \right)^{-1/(k-1)}$$

$$\frac{T}{T_0} = \left(1 + \frac{k-1}{2} \text{Ma}^2 \right)^{-1}$$

k=1.667

PP0=(1+(k-1)*M^2/2)^(-k/(k-1))

TT0=1/(1+(k-1)*M^2/2)

DD0=(1+(k-1)*M^2/2)^(-1/(k-1))

Mcr=M*SQRT((k+1)/(2+(k-1)*M^2))

AAcr=((2/(k+1))*(1+0.5*(k-1)*M^2)^(0.5*(k+1)/(k-1)))/M

Ma	Ma*	A/A*	P/P ₀	ρ/ρ ₀	T/T ₀
0.0	0	∞	1.0000	1.0000	1.0000
0.1	0.1153	5.6624	0.9917	0.9950	0.9967
0.2	0.2294	2.8879	0.9674	0.9803	0.9868
0.3	0.3413	1.9891	0.9288	0.9566	0.9709
0.4	0.4501	1.5602	0.8782	0.9250	0.9493
0.5	0.5547	1.3203	0.8186	0.8869	0.9230
0.6	0.6547	1.1760	0.7532	0.8437	0.8928
0.7	0.7494	1.0875	0.6850	0.7970	0.8595
0.8	0.8386	1.0351	0.6166	0.7482	0.8241
0.9	0.9222	1.0081	0.5501	0.6987	0.7873
1.0	1.0000	1.0000	0.4871	0.6495	0.7499
1.2	1.1390	1.0267	0.3752	0.5554	0.6756
1.4	1.2572	1.0983	0.2845	0.4704	0.6047
1.6	1.3570	1.2075	0.2138	0.3964	0.5394
1.8	1.4411	1.3519	0.1603	0.3334	0.4806
2.0	1.5117	1.5311	0.1202	0.2806	0.4284
2.2	1.5713	1.7459	0.0906	0.2368	0.3825
2.4	1.6216	1.9980	0.0686	0.2005	0.3424
2.6	1.6643	2.2893	0.0524	0.1705	0.3073
2.8	1.7007	2.6222	0.0403	0.1457	0.2767
3.0	1.7318	2.9990	0.0313	0.1251	0.2499
5.0	1.8895	9.7920	0.0038	0.0351	0.1071
∞	1.9996	∞	0	0	0

Discussion The tabulated values are useful for quick calculations, but be careful – they apply only to one specific value of k , in this case $k = 1.667$.



17-139 Using the normal shock relations, the normal shock functions are to be evaluated and tabulated as in Table A-33 for an ideal gas with $k = 1.667$.

Properties The specific heat ratio of the ideal gas is given to be $k = 1.667$.

Analysis The normal shock relations listed below are expressed in EES and the results are tabulated.

$$Ma_2 = \sqrt{\frac{(k-1)Ma_1^2 + 2}{2kMa_1^2 - k + 1}} \qquad \frac{P_2}{P_1} = \frac{1 + kMa_1^2}{1 + kMa_2^2} = \frac{2kMa_1^2 - k + 1}{k + 1}$$

$$\frac{T_2}{T_1} = \frac{2 + Ma_1^2(k-1)}{2 + Ma_2^2(k-1)} \qquad \frac{\rho_2}{\rho_1} = \frac{P_2 / P_1}{T_2 / T_1} = \frac{(k+1)Ma_1^2}{2 + (k-1)Ma_1^2} = \frac{V_1}{V_2}$$

$$\frac{P_{02}}{P_{01}} = \frac{Ma_1}{Ma_2} \left[\frac{1 + Ma_2^2(k-1)/2}{1 + Ma_1^2(k-1)/2} \right]^{\frac{k+1}{2(k-1)}} \qquad \frac{P_{02}}{P_1} = \frac{(1 + kMa_1^2)[1 + Ma_2^2(k-1)/2]^{k/(k-1)}}{1 + kMa_2^2}$$

```

k=1.667
My=SQRT((Mx^2+2/(k-1))/(2*Mx^2*k/(k-1)-1))
PyPx=(1+k*Mx^2)/(1+k*My^2)
TyTx=(1+Mx^2*(k-1)/2)/(1+My^2*(k-1)/2)
RyRx=PyPx/TyTx
P0yP0x=(Mx/My)*((1+My^2*(k-1)/2)/(1+Mx^2*(k-1)/2))^(0.5*(k+1)/(k-1))
P0yPx=(1+k*Mx^2)*(1+My^2*(k-1)/2)^(k/(k-1))/(1+k*My^2)
    
```

Ma ₁	Ma ₂	P ₂ /P ₁	ρ ₂ /ρ ₁	T ₂ /T ₁	P ₀₂ /P ₀₁	P ₀₂ /P ₁
1.0	1.0000	1.0000	1.0000	1.0000	1	2.0530
1.1	0.9131	1.2625	1.1496	1.0982	0.999	2.3308
1.2	0.8462	1.5500	1.2972	1.1949	0.9933	2.6473
1.3	0.7934	1.8626	1.4413	1.2923	0.9813	2.9990
1.4	0.7508	2.2001	1.5805	1.3920	0.9626	3.3838
1.5	0.7157	2.5626	1.7141	1.4950	0.938	3.8007
1.6	0.6864	2.9501	1.8415	1.6020	0.9085	4.2488
1.7	0.6618	3.3627	1.9624	1.7135	0.8752	4.7278
1.8	0.6407	3.8002	2.0766	1.8300	0.8392	5.2371
1.9	0.6227	4.2627	2.1842	1.9516	0.8016	5.7767
2.0	0.6070	4.7503	2.2853	2.0786	0.763	6.3462
2.1	0.5933	5.2628	2.3802	2.2111	0.7243	6.9457
2.2	0.5814	5.8004	2.4689	2.3493	0.6861	7.5749
2.3	0.5708	6.3629	2.5520	2.4933	0.6486	8.2339
2.4	0.5614	6.9504	2.6296	2.6432	0.6124	8.9225
2.5	0.5530	7.5630	2.7021	2.7989	0.5775	9.6407
2.6	0.5455	8.2005	2.7699	2.9606	0.5442	10.3885
2.7	0.5388	8.8631	2.8332	3.1283	0.5125	11.1659
2.8	0.5327	9.5506	2.8923	3.3021	0.4824	11.9728
2.9	0.5273	10.2632	2.9476	3.4819	0.4541	12.8091
3.0	0.5223	11.0007	2.9993	3.6678	0.4274	13.6750
4.0	0.4905	19.7514	3.3674	5.8654	0.2374	23.9530
5.0	0.4753	31.0022	3.5703	8.6834	0.1398	37.1723
∞	0.4473	∞	3.9985	∞	0	∞

Discussion The tabulated values are useful for quick calculations, but be careful – they apply only to one specific value of k , in this case $k = 1.667$.

17-140 Helium gas is accelerated in a nozzle isentropically. For a specified mass flow rate, the throat and exit areas of the nozzle are to be determined.

Assumptions 1 Helium is an ideal gas with constant specific heats. 2 Flow through the nozzle is steady, one-dimensional, and isentropic. 3 The nozzle is adiabatic.

Properties The properties of helium are $R = 2.0769 \text{ kJ/kg}\cdot\text{K}$, $c_p = 5.1926 \text{ kJ/kg}\cdot\text{K}$, and $k = 1.667$.

Analysis The inlet stagnation properties in this case are identical to the inlet properties since the inlet velocity is negligible,

$$\begin{aligned} T_{01} &= T_1 = 500 \text{ K} \\ P_{01} &= P_1 = 1.0 \text{ MPa} \end{aligned}$$

The flow is assumed to be isentropic, thus the stagnation temperature and pressure remain constant throughout the nozzle,

$$\begin{aligned} T_{02} &= T_{01} = 500 \text{ K} \\ P_{02} &= P_{01} = 1.0 \text{ MPa} \end{aligned}$$

The critical pressure and temperature are determined from

$$T^* = T_0 \left(\frac{2}{k+1} \right) = (500 \text{ K}) \left(\frac{2}{1.667+1} \right) = 375.0 \text{ K}$$

$$P^* = P_0 \left(\frac{2}{k+1} \right)^{k/(k-1)} = (1.0 \text{ MPa}) \left(\frac{2}{1.667+1} \right)^{1.667/(1.667-1)} = 0.487 \text{ MPa}$$

$$\rho^* = \frac{P^*}{RT^*} = \frac{487 \text{ kPa}}{(2.0769 \text{ kPa}\cdot\text{m}^3/\text{kg}\cdot\text{K})(375 \text{ K})} = 0.625 \text{ kg/m}^3$$

$$V^* = c^* = \sqrt{kRT^*} = \sqrt{(1.667)(2.0769 \text{ kJ/kg}\cdot\text{K})(375 \text{ K}) \left(\frac{1000 \text{ m}^2/\text{s}^2}{1 \text{ kJ/kg}} \right)} = 1139.4 \text{ m/s}$$

Thus the throat area is

$$A^* = \frac{\dot{m}}{\rho^* V^*} = \frac{0.46 \text{ kg/s}}{(0.625 \text{ kg/m}^3)(1139.4 \text{ m/s})} = 6.460 \times 10^{-4} \text{ m}^2 = \mathbf{6.46 \text{ cm}^2}$$

At the nozzle exit the pressure is $P_2 = 0.1 \text{ MPa}$. Then the other properties at the nozzle exit are determined to be

$$\frac{P_0}{P_2} = \left(1 + \frac{k-1}{2} \text{Ma}_2^2 \right)^{k/(k-1)} \longrightarrow \frac{1.0 \text{ MPa}}{0.1 \text{ MPa}} = \left(1 + \frac{1.667-1}{2} \text{Ma}_2^2 \right)^{1.667/0.667}$$

It yields $\text{Ma}_2 = 2.130$, which is greater than 1. Therefore, the nozzle must be converging-diverging.

$$T_2 = T_0 \left(\frac{2}{2+(k-1)\text{Ma}_2^2} \right) = (500 \text{ K}) \left(\frac{2}{2+(1.667-1) \times 2.13^2} \right) = 199.0 \text{ K}$$

$$\rho_2 = \frac{P_2}{RT_2} = \frac{100 \text{ kPa}}{(2.0769 \text{ kPa}\cdot\text{m}^3/\text{kg}\cdot\text{K})(199 \text{ K})} = 0.242 \text{ kg/m}^3$$

$$V_2 = \text{Ma}_2 c_2 = \text{Ma}_2 \sqrt{kRT_2} = (2.13) \sqrt{(1.667)(2.0769 \text{ kJ/kg}\cdot\text{K})(199 \text{ K}) \left(\frac{1000 \text{ m}^2/\text{s}^2}{1 \text{ kJ/kg}} \right)} = 1768.0 \text{ m/s}$$

Thus the exit area is

$$A_2 = \frac{\dot{m}}{\rho_2 V_2} = \frac{0.46 \text{ kg/s}}{(0.242 \text{ kg/m}^3)(1768 \text{ m/s})} = 0.1075 \times 10^{-3} \text{ m}^2 \cong \mathbf{10.8 \text{ cm}^2}$$

Discussion Flow areas in actual nozzles would be somewhat larger to accommodate the irreversibilities.

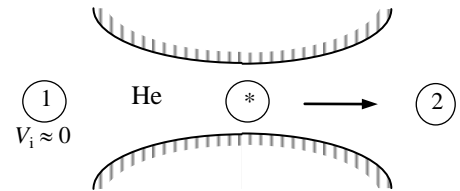



17-141 Using the normal shock relations, the normal shock functions are to be evaluated and tabulated as in Table A-33 for air.

Properties The specific heat ratio is given to be $k = 1.4$ for air.

Analysis The normal shock relations listed below are expressed in EES and the results are tabulated.

$$Ma_2 = \sqrt{\frac{(k-1)Ma_1^2 + 2}{2kMa_1^2 - k + 1}}$$

$$\frac{P_2}{P_1} = \frac{1 + kMa_1^2}{1 + kMa_2^2} = \frac{2kMa_1^2 - k + 1}{k + 1}$$

$$\frac{T_2}{T_1} = \frac{2 + Ma_1^2(k-1)}{2 + Ma_2^2(k-1)}$$

$$\frac{\rho_2}{\rho_1} = \frac{P_2 / P_1}{T_2 / T_1} = \frac{(k+1)Ma_1^2}{2 + (k-1)Ma_1^2} = \frac{V_1}{V_2}$$

$$\frac{P_{02}}{P_{01}} = \frac{Ma_1}{Ma_2} \left[\frac{1 + Ma_2^2(k-1)/2}{1 + Ma_1^2(k-1)/2} \right]^{\frac{k+1}{2(k-1)}}$$

$$\frac{P_{02}}{P_1} = \frac{(1 + kMa_1^2)[1 + Ma_2^2(k-1)/2]^{k/(k-1)}}{1 + kMa_2^2}$$

Air:

$$k=1.4$$

$$My = \text{SQRT}((Mx^2 + 2/(k-1))/(2*Mx^2*k/(k-1) - 1))$$

$$PyPx = (1 + k*Mx^2)/(1 + k*My^2)$$

$$TyTx = (1 + Mx^2*(k-1)/2)/(1 + My^2*(k-1)/2)$$

$$RyRx = PyPx/TyTx$$

$$P0yP0x = (Mx/My)*((1 + My^2*(k-1)/2)/(1 + Mx^2*(k-1)/2))^{0.5*(k+1)/(k-1)}$$

$$P0yPx = (1 + k*Mx^2)*(1 + My^2*(k-1)/2)^{k/(k-1)}/(1 + k*My^2)$$

Ma ₁	Ma ₂	P ₂ /P ₁	ρ ₂ /ρ ₁	T ₂ /T ₁	P ₀₂ /P ₀₁	P ₀₂ /P ₁
1.0	1.0000	1.0000	1.0000	1.0000	1	1.8929
1.5	0.7011	2.4583	1.8621	1.3202	0.9298	3.4133
2.0	0.5774	4.5000	2.6667	1.6875	0.7209	5.6404
2.5	0.5130	7.1250	3.3333	2.1375	0.499	8.5261
3.0	0.4752	10.3333	3.8571	2.6790	0.3283	12.0610
3.5	0.4512	14.1250	4.2609	3.3151	0.2129	16.2420
4.0	0.4350	18.5000	4.5714	4.0469	0.1388	21.0681
4.5	0.4236	23.4583	4.8119	4.8751	0.0917	26.5387
5.0	0.4152	29.0000	5.0000	5.8000	0.06172	32.6535
5.5	0.4090	35.1250	5.1489	6.8218	0.04236	39.4124
6.0	0.4042	41.8333	5.2683	7.9406	0.02965	46.8152
6.5	0.4004	49.1250	5.3651	9.1564	0.02115	54.8620
7.0	0.3974	57.0000	5.4444	10.4694	0.01535	63.5526
7.5	0.3949	65.4583	5.5102	11.8795	0.01133	72.8871
8.0	0.3929	74.5000	5.5652	13.3867	0.008488	82.8655
8.5	0.3912	84.1250	5.6117	14.9911	0.006449	93.4876
9.0	0.3898	94.3333	5.6512	16.6927	0.004964	104.7536
9.5	0.3886	105.1250	5.6850	18.4915	0.003866	116.6634
10.0	0.3876	116.5000	5.7143	20.3875	0.003045	129.2170

Discussion The tabulated values are useful for quick calculations, but be careful – they apply only to one specific value of k , in this case $k = 1.4$.



17-142 Using the normal shock relations, the normal shock functions are to be evaluated and tabulated as in Table A-33 for methane.

Properties The specific heat ratio is given to be $k = 1.3$ for methane.

Analysis The normal shock relations listed below are expressed in EES and the results are tabulated.

$$\text{Ma}_2 = \sqrt{\frac{(k-1)\text{Ma}_1^2 + 2}{2k\text{Ma}_1^2 - k + 1}}$$

$$\frac{P_2}{P_1} = \frac{1 + k\text{Ma}_1^2}{1 + k\text{Ma}_2^2} = \frac{2k\text{Ma}_1^2 - k + 1}{k + 1}$$

$$\frac{T_2}{T_1} = \frac{2 + \text{Ma}_1^2(k-1)}{2 + \text{Ma}_2^2(k-1)}$$

$$\frac{\rho_2}{\rho_1} = \frac{P_2 / P_1}{T_2 / T_1} = \frac{(k+1)\text{Ma}_1^2}{2 + (k-1)\text{Ma}_1^2} = \frac{V_1}{V_2}$$

$$\frac{P_{02}}{P_{01}} = \frac{\text{Ma}_1}{\text{Ma}_2} \left[\frac{1 + \text{Ma}_2^2(k-1)/2}{1 + \text{Ma}_1^2(k-1)/2} \right]^{\frac{k+1}{2(k-1)}}$$

$$\frac{P_{02}}{P_1} = \frac{(1 + k\text{Ma}_1^2)[1 + \text{Ma}_2^2(k-1)/2]^{k/(k-1)}}{1 + k\text{Ma}_2^2}$$

Methane:

$$k=1.3$$

$$\text{My} = \text{SQRT}((\text{Mx}^2 + 2/(k-1))/(2*\text{Mx}^2*k/(k-1) - 1))$$

$$\text{PyPx} = (1 + k*\text{Mx}^2)/(1 + k*\text{My}^2)$$

$$\text{TyTx} = (1 + \text{Mx}^2*(k-1)/2)/(1 + \text{My}^2*(k-1)/2)$$

$$\text{RyRx} = \text{PyPx}/\text{TyTx}$$

$$\text{P0yP0x} = (\text{Mx}/\text{My}) * ((1 + \text{My}^2*(k-1)/2)/(1 + \text{Mx}^2*(k-1)/2))^{(0.5*(k+1)/(k-1))}$$

$$\text{P0yPx} = (1 + k*\text{Mx}^2) * (1 + \text{My}^2*(k-1)/2)^{(k/(k-1))} / (1 + k*\text{My}^2)$$

Ma ₁	Ma ₂	P ₂ /P ₁	ρ ₂ /ρ ₁	T ₂ /T ₁	P ₀₂ /P ₀₁	P ₀₂ /P ₁
1.0	1.0000	1.0000	1.0000	1.0000	1	1.8324
1.5	0.6942	2.4130	1.9346	1.2473	0.9261	3.2654
2.0	0.5629	4.3913	2.8750	1.5274	0.7006	5.3700
2.5	0.4929	6.9348	3.7097	1.8694	0.461	8.0983
3.0	0.4511	10.0435	4.4043	2.2804	0.2822	11.4409
3.5	0.4241	13.7174	4.9648	2.7630	0.1677	15.3948
4.0	0.4058	17.9565	5.4118	3.3181	0.09933	19.9589
4.5	0.3927	22.7609	5.7678	3.9462	0.05939	25.1325
5.0	0.3832	28.1304	6.0526	4.6476	0.03613	30.9155
5.5	0.3760	34.0652	6.2822	5.4225	0.02243	37.3076
6.0	0.3704	40.5652	6.4688	6.2710	0.01422	44.3087
6.5	0.3660	47.6304	6.6218	7.1930	0.009218	51.9188
7.0	0.3625	55.2609	6.7485	8.1886	0.006098	60.1379
7.5	0.3596	63.4565	6.8543	9.2579	0.004114	68.9658
8.0	0.3573	72.2174	6.9434	10.4009	0.002827	78.4027
8.5	0.3553	81.5435	7.0190	11.6175	0.001977	88.4485
9.0	0.3536	91.4348	7.0837	12.9079	0.001404	99.1032
9.5	0.3522	101.8913	7.1393	14.2719	0.001012	110.367
10.0	0.3510	112.9130	7.1875	15.7096	0.000740	122.239

Discussion The tabulated values are useful for quick calculations, but be careful – they apply only to one specific value of k , in this case $k = 1.3$.

17-143 Air flowing at a subsonic velocity in a duct is accelerated by heating. The highest rate of heat transfer without affecting the inlet conditions is to be determined.

Assumptions 1 The assumptions associated with Rayleigh flow (i.e., steady one-dimensional flow of an ideal gas with constant properties through a constant cross-sectional area duct with negligible frictional effects) are valid. 2 Inlet conditions (and thus the mass flow rate) remain constant.

Properties We take the properties of air to be $k = 1.4$, $c_p = 1.005 \text{ kJ/kg}\cdot\text{K}$, and $R = 0.287 \text{ kJ/kg}\cdot\text{K}$.

Analysis Heat transfer will stop when the flow is choked, and thus $\text{Ma}_2 = V_2/c_2 = 1$. The inlet density and stagnation temperature are

$$\rho_1 = \frac{P_1}{RT_1} = \frac{350 \text{ kPa}}{(0.287 \text{ kJ/kg}\cdot\text{K})(420 \text{ K})} = 2.904 \text{ kg/m}^3$$

$$T_{01} = T_1 \left(1 + \frac{k-1}{2} \text{Ma}_1^2 \right) = (420 \text{ K}) \left(1 + \frac{1.4-1}{2} 0.6^2 \right) = 450.2 \text{ K}$$

Then the inlet velocity and the mass flow rate become

$$c_1 = \sqrt{kRT_1} = \sqrt{(1.4)(0.287 \text{ kJ/kg}\cdot\text{K})(420 \text{ K}) \left(\frac{1000 \text{ m}^2/\text{s}^2}{1 \text{ kJ/kg}} \right)} = 410.8 \text{ m/s}$$

$$V_1 = \text{Ma}_1 c_1 = 0.6(410.8 \text{ m/s}) = 246.5 \text{ m/s}$$

$$\dot{m}_{\text{air}} = \rho_1 A_{\text{cl}} V_1 = (2.904 \text{ kg/m}^3)(0.1 \times 0.1 \text{ m}^2)(246.5 \text{ m/s}) = 7.157 \text{ kg/s}$$

The Rayleigh flow functions corresponding to the inlet and exit Mach numbers are $T_{02}/T_0^* = 1$ (since $\text{Ma}_2 = 1$).

$$\frac{T_{01}}{T_0^*} = \frac{(k+1)\text{Ma}_1^2 [2 + (k-1)\text{Ma}_1^2]}{(1+k\text{Ma}_1^2)^2} = \frac{(1.4+1)0.6^2 [2 + (1.4-1)0.6^2]}{(1+1.4 \times 0.6^2)^2} = 0.8189$$

Therefore,

$$\frac{T_{02}}{T_{01}} = \frac{T_{02}/T_0^*}{T_{01}/T_0^*} = \frac{1}{0.8189} \quad \rightarrow \quad T_{02} = T_{01}/0.8189 = (450.2 \text{ K})/0.8189 = 549.8 \text{ K}$$

Then the rate of heat transfer becomes

$$\dot{Q} = \dot{m}_{\text{air}} c_p (T_{02} - T_{01}) = (7.157 \text{ kg/s})(1.005 \text{ kJ/kg}\cdot\text{K})(549.8 - 450.2) \text{ K} = \mathbf{716 \text{ kW}}$$

Discussion It can also be shown that $T_2 = 458 \text{ K}$, which is the highest thermodynamic temperature that can be attained under stated conditions. If more heat is transferred, the additional temperature rise will cause the mass flow rate to decrease. We can also solve this problem using the Rayleigh function values listed in Table A-34.

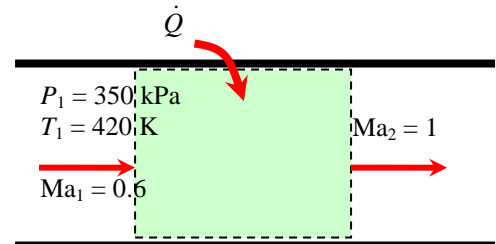

17-144 Helium flowing at a subsonic velocity in a duct is accelerated by heating. The highest rate of heat transfer without affecting the inlet conditions is to be determined.

Assumptions 1 The assumptions associated with Rayleigh flow (i.e., steady one-dimensional flow of an ideal gas with constant properties through a constant cross-sectional area duct with negligible frictional effects) are valid. 2 Inlet conditions (and thus the mass flow rate) remain constant.

Properties We take the properties of helium to be $k = 1.667$, $c_p = 5.193 \text{ kJ/kg}\cdot\text{K}$, and $R = 2.077 \text{ kJ/kg}\cdot\text{K}$.

Analysis Heat transfer will stop when the flow is choked, and thus $\text{Ma}_2 = V_2/c_2 = 1$. The inlet density and stagnation temperature are

$$\rho_1 = \frac{P_1}{RT_1} = \frac{350 \text{ kPa}}{(2.077 \text{ kJ/kg}\cdot\text{K})(420 \text{ K})} = 0.4012 \text{ kg/m}^3$$

$$T_{01} = T_1 \left(1 + \frac{k-1}{2} \text{Ma}_1^2 \right) = (420 \text{ K}) \left(1 + \frac{1.667-1}{2} 0.6^2 \right) = 470.4 \text{ K}$$

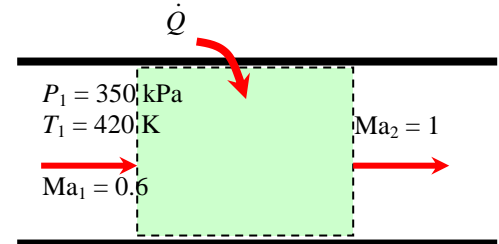

Then the inlet velocity and the mass flow rate become

$$c_1 = \sqrt{kRT_1} = \sqrt{(1.667)(2.077 \text{ kJ/kg}\cdot\text{K})(420 \text{ K}) \left(\frac{1000 \text{ m}^2/\text{s}^2}{1 \text{ kJ/kg}} \right)} = 1206 \text{ m/s}$$

$$V_1 = \text{Ma}_1 c_1 = 0.6(1206 \text{ m/s}) = 723.5 \text{ m/s}$$

$$\dot{m}_{\text{air}} = \rho_1 A_{\text{cl}} V_1 = (0.4012 \text{ kg/m}^3)(0.1 \times 0.1 \text{ m}^2)(723.5 \text{ m/s}) = 2.903 \text{ kg/s}$$

The Rayleigh flow functions corresponding to the inlet and exit Mach numbers are $T_{02}/T_0^* = 1$ (since $\text{Ma}_2 = 1$)

$$\frac{T_{01}}{T_0^*} = \frac{(k+1)\text{Ma}_1^2 [2 + (k-1)\text{Ma}_1^2]}{(1+k\text{Ma}_1^2)^2} = \frac{(1.667+1)0.6^2 [2 + (1.667-1)0.6^2]}{(1+1.667 \times 0.6^2)^2} = 0.8400$$

Therefore,

$$\frac{T_{02}}{T_{01}} = \frac{T_{02}/T_0^*}{T_{01}/T_0^*} = \frac{1}{0.8400} \quad \rightarrow \quad T_{02} = T_{01} / 0.8400 = (470.4 \text{ K}) / 0.8400 = 560.0 \text{ K}$$

Then the rate of heat transfer becomes

$$\dot{Q} = \dot{m}_{\text{air}} c_p (T_{02} - T_{01}) = (2.903 \text{ kg/s})(5.193 \text{ kJ/kg}\cdot\text{K})(560.0 - 470.4) \text{ K} = \mathbf{1350 \text{ kW}}$$

Discussion It can also be shown that $T_2 = 420 \text{ K}$, which is the highest thermodynamic temperature that can be attained under stated conditions. If more heat is transferred, the additional temperature rise will cause the mass flow rate to decrease. Also, in the solution of this problem, we cannot use the values of Table A-34 since they are based on $k = 1.4$.

17-145 Air flowing at a subsonic velocity in a duct is accelerated by heating. For a specified exit Mach number, the heat transfer for a specified exit Mach number as well as the maximum heat transfer are to be determined.

Assumptions 1 The assumptions associated with Rayleigh flow (i.e., steady one-dimensional flow of an ideal gas with constant properties through a constant cross-sectional area duct with negligible frictional effects) are valid. 2 Inlet conditions (and thus the mass flow rate) remain constant.

Properties We take the properties of air to be $k = 1.4$, $c_p = 1.005$ kJ/kg·K, and $R = 0.287$ kJ/kg·K.

Analysis The inlet Mach number and stagnation temperature are

$$c_1 = \sqrt{kRT_1} = \sqrt{(1.4)(0.287 \text{ kJ/kg} \cdot \text{K})(400 \text{ K}) \left(\frac{1000 \text{ m}^2/\text{s}^2}{1 \text{ kJ/kg}} \right)} = 400.9 \text{ m/s}$$

$$\text{Ma}_1 = \frac{V_1}{c_1} = \frac{100 \text{ m/s}}{400.9 \text{ m/s}} = 0.2494$$

$$T_{01} = T_1 \left(1 + \frac{k-1}{2} \text{Ma}_1^2 \right) = (400 \text{ K}) \left(1 + \frac{1.4-1}{2} 0.2494^2 \right) = 405.0 \text{ K}$$

The Rayleigh flow functions corresponding to the inlet and exit Mach numbers are (Table A-34):

$$\text{Ma}_1 = 0.2494: \quad T_{01}/T^* = 0.2559$$

$$\text{Ma}_2 = 0.8: \quad T_{02}/T^* = 0.9639$$

Then the exit stagnation temperature and the heat transfer are determined to be

$$\frac{T_{02}}{T_{01}} = \frac{T_{02}/T^*}{T_{01}/T^*} = \frac{0.9639}{0.2559} = 3.7667 \quad \rightarrow \quad T_{02} = 3.7667 T_{01} = 3.7667(405.0 \text{ K}) = 1526 \text{ K}$$

$$q = c_p (T_{02} - T_{01}) = (1.005 \text{ kJ/kg} \cdot \text{K})(1526 - 405) \text{ K} = 1126 \text{ kJ/kg} \cong \mathbf{1130 \text{ kJ/kg}}$$

Maximum heat transfer will occur when the flow is choked, and thus $\text{Ma}_2 = 1$ and thus $T_{02}/T^* = 1$. Then,

$$\frac{T_{02}}{T_{01}} = \frac{T_{02}/T^*}{T_{01}/T^*} = \frac{1}{0.2559} \quad \rightarrow \quad T_{02} = T_{01} / 0.2559 = (405 \text{ K}) / 0.2559 = 1583 \text{ K}$$

$$q_{\max} = c_p (T_{02} - T_{01}) = (1.005 \text{ kJ/kg} \cdot \text{K})(1583 - 405) \text{ K} = 1184 \text{ kJ/kg} \cong \mathbf{1180 \text{ kJ/kg}}$$

Discussion This is the maximum heat that can be transferred to the gas without affecting the mass flow rate. If more heat is transferred, the additional temperature rise will cause the mass flow rate to decrease.

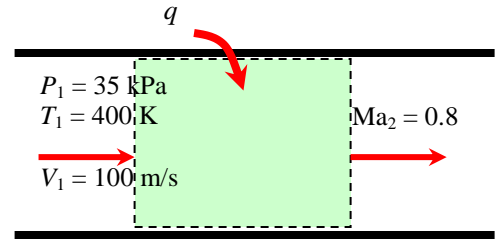

17-146 Air flowing at sonic conditions in a duct is accelerated by cooling. For a specified exit Mach number, the amount of heat transfer per unit mass is to be determined.

Assumptions The assumptions associated with Rayleigh flow (i.e., steady one-dimensional flow of an ideal gas with constant properties through a constant cross-sectional area duct with negligible frictional effects) are valid.

Properties We take the properties of air to be $k = 1.4$, $c_p = 1.005 \text{ kJ/kg}\cdot\text{K}$, and $R = 0.287 \text{ kJ/kg}\cdot\text{K}$.

Analysis Noting that $\text{Ma}_1 = 1$, the inlet stagnation temperature is

$$T_{01} = T_1 \left(1 + \frac{k-1}{2} \text{Ma}_1^2 \right) = (340 \text{ K}) \left(1 + \frac{1.4-1}{2} 1^2 \right) = 408 \text{ K}$$

The Rayleigh flow functions T_0/T_0^* corresponding to the inlet and exit Mach numbers are (Table A-34):

$$\text{Ma}_1 = 1: \quad T_{01}/T_0^* = 1$$

$$\text{Ma}_2 = 1.6: \quad T_{02}/T_0^* = 0.8842$$

Then the exit stagnation temperature and heat transfer are determined to be

$$\frac{T_{02}}{T_{01}} = \frac{T_{02}/T_0^*}{T_{01}/T_0^*} = \frac{0.8842}{1} = 0.8842 \quad \rightarrow \quad T_{02} = 0.8842 T_{01} = 0.8842(408 \text{ K}) = 360.75 \text{ K}$$

$$q = c_p (T_{02} - T_{01}) = (1.005 \text{ kJ/kg}\cdot\text{K})(360.75 - 408) \text{ K} = -47.49 \text{ kJ/kg} \cong \mathbf{-47.5 \text{ kJ/kg}}$$

Discussion The negative sign confirms that the gas needs to be cooled in order to be accelerated.

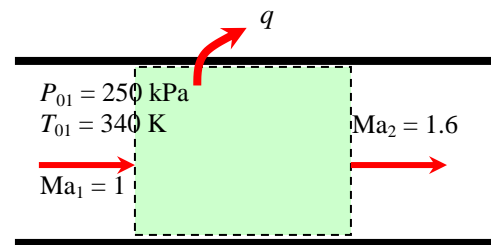

17-147 Air flowing at a supersonic velocity in a duct is accelerated by cooling. For a specified exit Mach number, the rate of heat transfer is to be determined.

Assumptions The assumptions associated with Rayleigh flow (i.e., steady one-dimensional flow of an ideal gas with constant properties through a constant cross-sectional area duct with negligible frictional effects) are valid.

Properties We take the properties of air to be $k = 1.4$, $c_p = 1.005$ kJ/kg·K, and $R = 0.287$ kJ/kg·K.

Analysis Knowing stagnation properties, the static properties are determined to be

$$T_1 = T_{01} \left(1 + \frac{k-1}{2} \text{Ma}_1^2 \right)^{-1} = (350 \text{ K}) \left(1 + \frac{1.4-1}{2} 1.2^2 \right)^{-1} = 271.7 \text{ K}$$

$$P_1 = P_{01} \left(1 + \frac{k-1}{2} \text{Ma}_1^2 \right)^{-k/(k-1)} = (240 \text{ kPa}) \left(1 + \frac{1.4-1}{2} 1.2^2 \right)^{-1.4/0.4} = 98.97 \text{ kPa}$$

$$\rho_1 = \frac{P_1}{RT_1} = \frac{98.97 \text{ kPa}}{(0.287 \text{ kJ/kgK})(271.7 \text{ K})} = 1.269 \text{ kg/m}^3$$

Then the inlet velocity and the mass flow rate become

$$c_1 = \sqrt{kRT_1} = \sqrt{(1.4)(0.287 \text{ kJ/kg} \cdot \text{K})(271.7 \text{ K}) \left(\frac{1000 \text{ m}^2/\text{s}^2}{1 \text{ kJ/kg}} \right)} = 330.4 \text{ m/s}$$

$$V_1 = \text{Ma}_1 c_1 = 1.2(330.4 \text{ m/s}) = 396.5 \text{ m/s}$$

$$\dot{m}_{\text{air}} = \rho_1 A_c V_1 = (1.269 \text{ kg/m}^3) [\pi(0.20 \text{ m})^2 / 4] (396.5 \text{ m/s}) = 15.81 \text{ kg/s}$$

The Rayleigh flow functions T_0/T_0^* corresponding to the inlet and exit Mach numbers are (Table A-34):

$$\text{Ma}_1 = 1.2: \quad T_{01}/T_0^* = 0.9787$$

$$\text{Ma}_2 = 2: \quad T_{02}/T_0^* = 0.7934$$

Then the exit stagnation temperature is determined to be

$$\frac{T_{02}}{T_{01}} = \frac{T_{02}/T_0^*}{T_{01}/T_0^*} = \frac{0.7934}{0.9787} = 0.8107 \quad \rightarrow \quad T_{02} = 0.8107 T_{01} = 0.8107(350 \text{ K}) = 283.7 \text{ K}$$

Finally, the rate of heat transfer is

$$\dot{Q} = \dot{m}_{\text{air}} c_p (T_{02} - T_{01}) = (15.81 \text{ kg/s})(1.005 \text{ kJ/kg} \cdot \text{K})(283.7 - 350) \text{ K} = -1053 \text{ kW} \cong \mathbf{-1050 \text{ kW}}$$

Discussion The negative sign confirms that the gas needs to be cooled in order to be accelerated. Also, it can be shown that the thermodynamic temperature drops to 158 K at the exit, which is extremely low. Therefore, the duct may need to be heavily insulated to maintain indicated flow conditions.

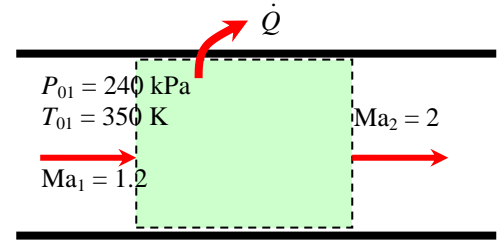

17-148 Saturated steam enters a converging-diverging nozzle with a low velocity. The throat area, exit velocity, mass flow rate, and exit Mach number are to be determined for isentropic and 90 percent efficient nozzle cases.

Assumptions 1 Flow through the nozzle is steady and one-dimensional.
2 The nozzle is adiabatic.

Analysis (a) The inlet stagnation properties in this case are identical to the inlet properties since the inlet velocity is negligible. Thus $h_{10} = h_1$. At the inlet,

$$h_1 = (h_f + x_1 h_{fg})_{@1.75 \text{ MPa}} = 878.16 + 0.90 \times 1917.1 = 2603.5 \text{ kJ/kg}$$

$$s_1 = (s_f + x_1 s_{fg})_{@1.75 \text{ MPa}} = 2.3844 + 0.90 \times 4.0033 = 5.9874 \text{ kJ/kg} \cdot \text{K}$$

At the exit, $P_2 = 1.2 \text{ MPa}$ and $s_2 = s_{2s} = s_1 = 5.9874 \text{ kJ/kg} \cdot \text{K}$. Thus,

$$s_2 = s_f + x_2 s_{fg} \rightarrow 5.9874 = 2.2159 + x_2(4.3058) \rightarrow x_2 = 0.8759$$

$$h_2 = h_f + x_2 h_{fg} = 798.33 + 0.8759 \times 1985.4 = 2537.4 \text{ kJ/kg}$$

$$\nu_2 = \nu_f + x_2 \nu_{fg} = 0.001138 + 0.8759 \times (0.16326 - 0.001138) = 0.14314 \text{ m}^3/\text{kg}$$

Then the exit velocity is determined from the steady-flow energy balance to be

$$h_1 + \frac{V_1^2}{2} = h_2 + \frac{V_2^2}{2} \rightarrow 0 = h_2 - h_1 + \frac{V_2^2 - V_1^2}{2}$$

Solving for V_2 ,

$$V_2 = \sqrt{2(h_1 - h_2)} = \sqrt{2(2603.5 - 2537.4) \text{ kJ/kg} \left(\frac{1000 \text{ m}^2/\text{s}^2}{1 \text{ kJ/kg}} \right)} = \mathbf{363.7 \text{ m/s}}$$

The mass flow rate is determined from

$$\dot{m} = \frac{1}{\nu_2} A_2 V_2 = \frac{1}{0.14314 \text{ m}^3/\text{kg}} (25 \times 10^{-4} \text{ m}^2)(363.7 \text{ m/s}) = \mathbf{6.35 \text{ kg/s}}$$

The velocity of sound at the exit of the nozzle is determined from

$$c = \left(\frac{\partial P}{\partial \nu} \right)_s^{1/2} \cong \left(\frac{\Delta P}{\Delta(1/\nu)} \right)_s^{1/2}$$

The specific volume of steam at $s_2 = 5.9874 \text{ kJ/kg} \cdot \text{K}$ and at pressures just below and just above the specified pressure (1.1 and 1.3 MPa) are determined to be 0.1547 and 0.1333 m^3/kg . Substituting,

$$c_2 = \sqrt{\left(\frac{1300 - 1100 \text{ kPa}}{0.1333 - 0.1547} \right) \text{ kg/m}^3 \left(\frac{1000 \text{ m}^2/\text{s}^2}{1 \text{ kPa} \cdot \text{m}^3} \right)} = 438.9 \text{ m/s}$$

Then the exit Mach number becomes

$$\text{Ma}_2 = \frac{V_2}{c_2} = \frac{363.7 \text{ m/s}}{438.9 \text{ m/s}} = \mathbf{0.829}$$

The steam is saturated, and thus the critical pressure which occurs at the throat is taken to be

$$P_t = P^* = 0.576 \times P_{01} = 0.576 \times 1.75 = 1.008 \text{ MPa}$$

Then at the throat,

$$P_t = 1.008 \text{ MPa} \text{ and } s_t = s_1 = 5.9874 \text{ kJ/kg} \cdot \text{K}$$

Thus,

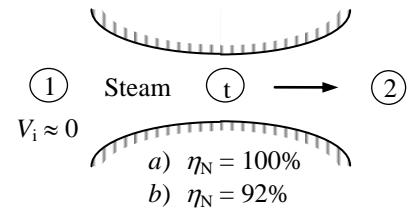

$$h_t = 2507.7 \text{ kJ/kg}$$

$$v_t = 0.1672 \text{ m}^3/\text{kg}$$

Then the throat velocity is determined from the steady-flow energy balance,

$$h_1 + \frac{V_1^2}{2} = h_t + \frac{V_t^2}{2} \rightarrow 0 = h_t - h_1 + \frac{V_t^2}{2}$$

Solving for V_t ,

$$V_t = \sqrt{2(h_1 - h_t)} = \sqrt{2(2603.5 - 2507.7) \text{ kJ/kg} \left(\frac{1000 \text{ m}^2/\text{s}^2}{1 \text{ kJ/kg}} \right)} = 437.7 \text{ m/s}$$

Thus the throat area is

$$A_t = \frac{\dot{m} v_t}{V_t} = \frac{(6.35 \text{ kg/s})(0.1672 \text{ m}^3/\text{kg})}{437.7 \text{ m/s}} = 24.26 \times 10^{-4} \text{ m}^2 = \mathbf{24.26 \text{ cm}^2}$$

(b) The inlet stagnation properties in this case are identical to the inlet properties since the inlet velocity is negligible. Thus $h_{10} = h_1$. At the inlet,

$$h_1 = (h_f + x_1 h_{fg})_{@1.75 \text{ MPa}} = 878.16 + 0.90 \times 1917.1 = 2603.5 \text{ kJ/kg}$$

$$s_1 = (s_f + x_1 s_{fg})_{@1.75 \text{ MPa}} = 2.3844 + 0.90 \times 4.0033 = 5.9874 \text{ kJ/kg} \cdot \text{K}$$

At state 2s, $P_2 = 1.2 \text{ MPa}$ and $s_2 = s_{2s} = s_1 = 5.9874 \text{ kJ/kg} \cdot \text{K}$. Thus,

$$s_{2s} = s_f + x_2 s_{fg} \rightarrow 5.9874 = 2.2159 + x_2(4.3058) \rightarrow x_{2s} = 0.8759$$

$$h_{2s} = h_f + x_2 h_{fg} = 798.33 + 0.8759 \times 1985.4 = 2537.4 \text{ kJ/kg}$$

The enthalpy of steam at the actual exit state is determined from

$$\eta_N = \frac{h_{01} - h_2}{h_{01} - h_{2s}} \rightarrow 0.92 = \frac{2603.5 - h_2}{2603.5 - 2537.4} \rightarrow h_2 = 2542.7 \text{ kJ/kg}$$

Therefore at the exit, $P_2 = 1.2 \text{ MPa}$ and $h_2 = 2542.7 \text{ kJ/kg} \cdot \text{K}$. Thus,

$$h_2 = h_f + x_2 h_{fg} \rightarrow 2542.7 = 798.33 + x_2(1985.4) \rightarrow x_2 = 0.8786$$

$$s_2 = s_f + x_2 s_{fg} = 2.2159 + 0.8786 \times 4.3058 = 5.9989$$

$$v_2 = v_f + x_2 v_{fg} = 0.001138 + 0.8786 \times (0.16326 - 0.001138) = 0.1436 \text{ m}^3/\text{kg}$$

Then the exit velocity is determined from the steady-flow energy balance to be

$$h_1 + \frac{V_1^2}{2} = h_2 + \frac{V_2^2}{2} \rightarrow 0 = h_2 - h_1 + \frac{V_2^2 - V_1^2}{2}$$

Solving for V_2 ,

$$V_2 = \sqrt{2(h_1 - h_2)} = \sqrt{2(2603.5 - 2542.7) \text{ kJ/kg} \left(\frac{1000 \text{ m}^2/\text{s}^2}{1 \text{ kJ/kg}} \right)} = \mathbf{348.9 \text{ m/s}}$$

The mass flow rate is determined from

$$\dot{m} = \frac{1}{v_2} A_2 V_2 = \frac{1}{0.1436 \text{ m}^3/\text{kg}} (25 \times 10^{-4} \text{ m}^2)(348.9 \text{ m/s}) = \mathbf{6.07 \text{ kg/s}}$$

The velocity of sound at the exit of the nozzle is determined from

$$c = \left(\frac{\partial \mathcal{P}}{\partial \rho} \right)_s \cong \left(\frac{\Delta \mathcal{P}}{\Delta(1/v)} \right)_s^{1/2}$$

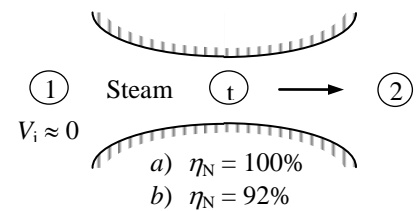

The specific volume of steam at $s_2 = 5.9989$ kJ/kg·K and at pressures just below and just above the specified pressure (1.1 and 1.3 MPa) are determined to be 0.1551 and 0.1337 m³/kg. Substituting,

$$c_2 = \sqrt{\frac{(1300 - 1100) \text{ kPa}}{\left(\frac{1}{0.1337} - \frac{1}{0.1551}\right) \text{ kg/m}^3} \left(\frac{1000 \text{ m}^2/\text{s}^2}{1 \text{ kPa} \cdot \text{m}^3}\right)} = 439.7 \text{ m/s}$$

Then the exit Mach number becomes

$$\text{Ma}_2 = \frac{V_2}{c_2} = \frac{348.9 \text{ m/s}}{439.7 \text{ m/s}} = \mathbf{0.793}$$

The steam is saturated, and thus the critical pressure which occurs at the throat is taken to be

$$P_t = P^* = 0.576 \times P_{01} = 0.576 \times 1.75 = 1.008 \text{ MPa}$$

At state 2ts, $P_{ts} = 1.008$ MPa and $s_{ts} = s_1 = 5.9874$ kJ/kg·K. Thus, $h_{ts} = 2507.7$ kJ/kg.

The actual enthalpy of steam at the throat is

$$\eta_N = \frac{h_{01} - h_t}{h_{01} - h_{ts}} \rightarrow 0.92 = \frac{2603.5 - h_t}{2603.5 - 2507.7} \rightarrow h_t = 2515.4 \text{ kJ/kg}$$

Therefore at the throat, $P_2 = 1.008$ MPa and $h_t = 2515.4$ kJ/kg. Thus, $v_t = 0.1679$ m³/kg.

Then the throat velocity is determined from the steady-flow energy balance,

$$h_1 + \frac{V_1^2}{2} = h_t + \frac{V_t^2}{2} \rightarrow 0 = h_t - h_1 + \frac{V_t^2}{2}$$

Solving for V_t ,

$$V_t = \sqrt{2(h_1 - h_t)} = \sqrt{2(2603.5 - 2515.4) \text{ kJ/kg} \left(\frac{1000 \text{ m}^2/\text{s}^2}{1 \text{ kJ/kg}}\right)} = 419.9 \text{ m/s}$$

Thus the throat area is

$$A_t = \frac{\dot{m} v_t}{V_t} = \frac{(6.07 \text{ kg/s})(0.1679 \text{ m}^3/\text{kg})}{419.9 \text{ m/s}} = 24.30 \times 10^{-4} \text{ m}^2 = \mathbf{24.30 \text{ cm}^2}$$



17-149 Using EES (or other) software, the shape of a converging-diverging nozzle is to be determined for specified flow rate and stagnation conditions. The nozzle and the Mach number are to be plotted.

Assumptions 1 Air is an ideal gas with constant specific heats. 2 Flow through the nozzle is steady, one-dimensional, and isentropic. 3 The nozzle is adiabatic.

Properties The specific heat ratio of air at room temperature is 1.4.

Analysis The problem is solved using EES, and the results are tabulated and plotted below.

```

k=1.4
Cp=1.005 "kJ/kg.K"
R=0.287 "kJ/kg.K"
P0=1400 "kPa"
T0=200+273 "K"
m=3 "kg/s"
rho_0=P0/(R*T0)
rho=P/(R*T)
T=T0*(P/P0)^((k-1)/k)
V=SQRT(2*Cp*(T0-T)*1000)
A=m/(rho*V)*10000 "cm2"
C=SQRT(k*R*T*1000)
Ma=V/C
    
```

Pressure <i>P</i> , kPa	Flow area <i>A</i> , cm ²	Mach number <i>Ma</i>
1400	∞	0
1350	30.1	0.229
1300	21.7	0.327
1250	18.1	0.406
1200	16.0	0.475
1150	14.7	0.538
1100	13.7	0.597
1050	13.0	0.655
1000	12.5	0.710
950	12.2	0.766
900	11.9	0.820
850	11.7	0.876
800	11.6	0.931
750	11.5	0.988
700	11.5	1.047
650	11.6	1.107
600	11.8	1.171
550	12.0	1.237
500	12.3	1.308
450	12.8	1.384
400	13.3	1.467
350	14.0	1.559
300	15.0	1.663
250	16.4	1.784
200	18.3	1.929
150	21.4	2.114
100	27.0	2.373

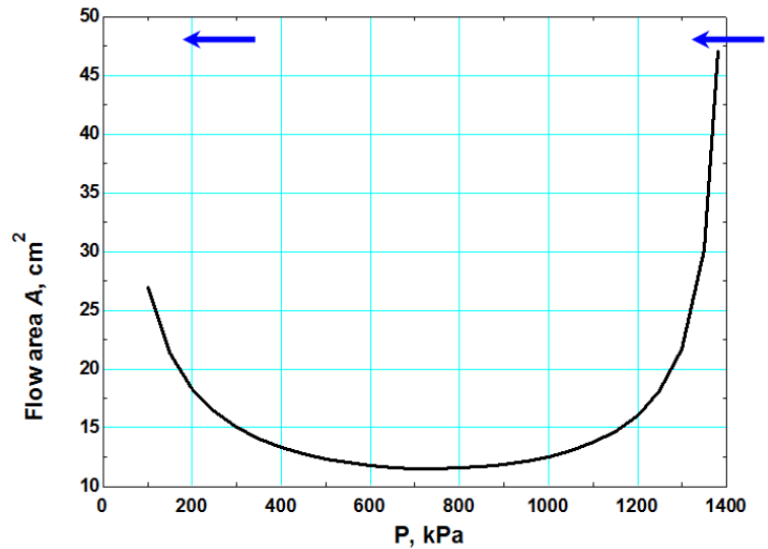
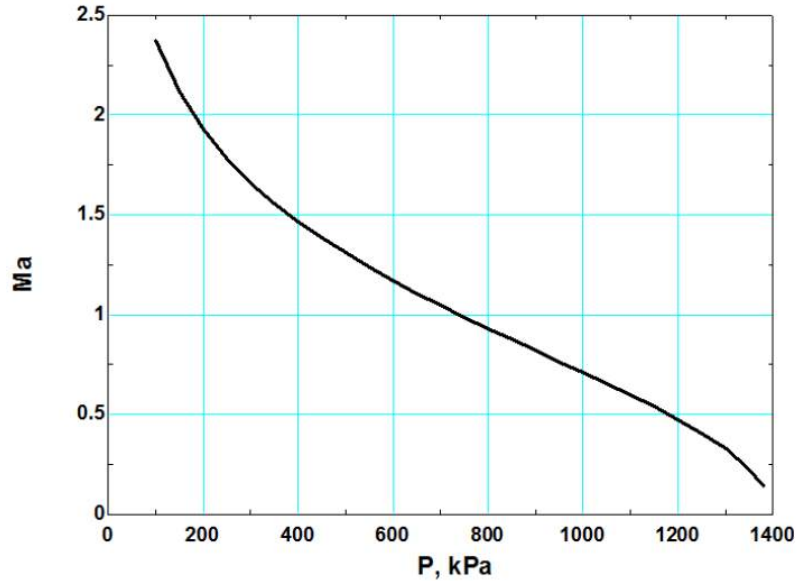

Discussion The shape is not actually to scale since the horizontal axis is pressure rather than distance. If the pressure decreases linearly with distance, then the shape *would* be to scale.



17-150 Steam enters a converging nozzle. The exit pressure, the exit velocity, and the mass flow rate versus the back pressure for a specified back pressure range are to be plotted.

Assumptions 1 Steam is to be treated as an ideal gas with constant specific heats. 2 Flow through the nozzle is steady, one-dimensional, and isentropic. 3 The nozzle is adiabatic.

Properties The ideal gas properties of steam are $R = 0.462 \text{ kJ/kg}\cdot\text{K}$, $c_p = 1.872 \text{ kJ/kg}\cdot\text{K}$, and $k = 1.3$.

Analysis We use EES to solve the problem. The stagnation properties in this case are identical to the inlet properties since the inlet velocity is negligible. Since the flow is isentropic, they remain constant throughout the nozzle,

$$P_0 = P_i = 6 \text{ MPa} \quad \text{and} \quad T_0 = T_i = 700 \text{ K}$$

The critical pressure is determined to be

$$P^* = P_0 \left(\frac{2}{k+1} \right)^{k/(k-1)} = (6 \text{ MPa}) \left(\frac{2}{1.3+1} \right)^{1.3/0.3} = 3.274 \text{ MPa}$$

Then the pressure at the exit plane (throat) is

$$P_e = P_b \quad \text{for} \quad P_b \geq 3.274 \text{ MPa}$$

$$P_e = P^* = 3.274 \text{ MPa} \quad \text{for} \quad P_b < 3.274 \text{ MPa} \quad (\text{choked flow})$$

Thus the back pressure does not affect the flow when $3 < P_b < 3.274$ MPa. For a specified exit pressure P_e , the temperature, velocity, and mass flow rate are

$$\text{Temperature} \quad T_e = T_0 \left(\frac{P_e}{P_0} \right)^{(k-1)/k} = (700 \text{ K}) \left(\frac{P_e}{6} \right)^{0.3/1.3}$$

$$\text{Velocity} \quad V = \sqrt{2c_p(T_0 - T_e)} = \sqrt{2(1.872 \text{ kJ/kg}\cdot\text{K})(700 - T_e) \left(\frac{1000 \text{ m}^2/\text{s}^2}{1 \text{ kJ/kg}} \right)}$$

$$\text{Density} \quad \rho_e = \frac{P_e}{RT_e} = \frac{P_e}{(0.462 \text{ kPa}\cdot\text{m}^3/\text{kg}\cdot\text{K})T_e}$$

$$\text{Mass flow rate} \quad \dot{m} = \rho_e V_e A_e = \rho_e V_e (0.0008 \text{ m}^2)$$

The results of the calculations are tabulated as follows:

P_b , MPa	P_e , MPa	T_e , K	V_e , m/s	ρ_e , kg/m ³	\dot{m} , kg/s
6.0	6.0	700	0	18.55	0
5.5	5.5	686.1	228.1	17.35	3.166
5.0	5.0	671.2	328.4	16.12	4.235
4.5	4.5	655.0	410.5	14.87	4.883
4.0	4.0	637.5	483.7	13.58	5.255
3.5	3.5	618.1	553.7	12.26	5.431
3.274	3.274	608.7	584.7	11.64	5.445
3.0	3.274	608.7	584.7	11.64	5.445

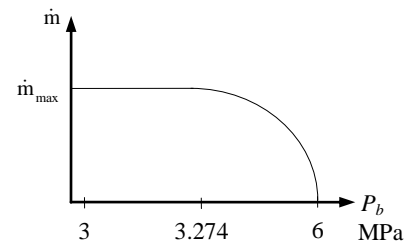
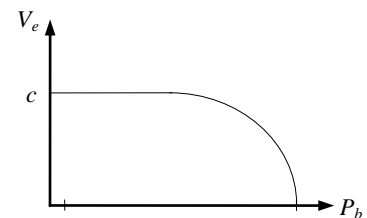
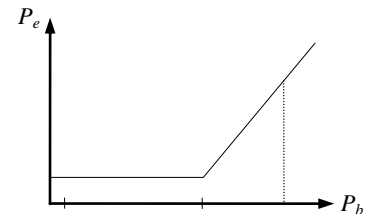
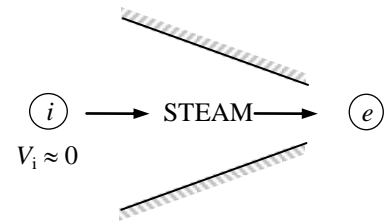

Discussion Once the back pressure drops below 3.274 MPa, the flow is choked, and \dot{m} remains constant from then on.

17-151 An expression for the ratio of the stagnation pressure after a shock wave to the static pressure before the shock wave as a function of k and the Mach number upstream of the shock wave is to be found.

Analysis The relation between P_1 and P_2 is

$$\frac{P_2}{P_1} = \frac{1 + k\text{Ma}_2^2}{1 + k\text{Ma}_1^2} \longrightarrow P_2 = P_1 \left(\frac{1 + k\text{Ma}_1^2}{1 + k\text{Ma}_2^2} \right)$$

We substitute this into the isentropic relation

$$\frac{P_{02}}{P_2} = \left(1 + (k-1)\text{Ma}_2^2 / 2 \right)^{k/(k-1)}$$

which yields

$$\frac{P_{02}}{P_1} = \left(\frac{1 + k\text{Ma}_1^2}{1 + k\text{Ma}_2^2} \right) \left(1 + (k-1)\text{Ma}_2^2 / 2 \right)^{k/(k-1)}$$

where

$$\text{Ma}_2^2 = \frac{\text{Ma}_1^2 + 2/(k-1)}{2k\text{Ma}_1^2/(k-1) - 1}$$

Substituting,

$$\boxed{\frac{P_{02}}{P_1} = \left(\frac{(1 + k\text{Ma}_1^2)(2k\text{Ma}_1^2 - k + 1)}{k\text{Ma}_1^2(k+1) - k + 3} \right) \left(1 + \frac{(k-1)\text{Ma}_1^2 / 2 + 1}{2k\text{Ma}_1^2/(k-1) - 1} \right)^{k/(k-1)}}$$

Discussion Similar manipulations of the equations can be performed to get the ratio of other parameters across a shock.



17-152 Using the compressible flow relations, the one-dimensional compressible flow functions are to be evaluated and tabulated as in Table A-32 for air.

Properties The specific heat ratio is given to be $k = 1.4$ for air.

Analysis The compressible flow functions listed below are expressed in EES and the results are tabulated.

$$\text{Ma}^* = \text{Ma} \sqrt{\frac{k+1}{2+(k-1)\text{Ma}^2}} \quad \frac{A}{A^*} = \frac{1}{\text{Ma}} \left[\left(\frac{2}{k+1} \right) \left(1 + \frac{k-1}{2} \text{Ma}^2 \right) \right]^{0.5(k+1)/(k-1)}$$

$$\frac{P}{P_0} = \left(1 + \frac{k-1}{2} \text{Ma}^2 \right)^{-k/(k-1)} \quad \frac{\rho}{\rho_0} = \left(1 + \frac{k-1}{2} \text{Ma}^2 \right)^{-1/(k-1)}$$

$$\frac{T}{T_0} = \left(1 + \frac{k-1}{2} \text{Ma}^2 \right)^{-1}$$

Air:

```

k=1.4
PP0=(1+(k-1)*M^2/2)^(-k/(k-1))
TT0=1/(1+(k-1)*M^2/2)
DD0=(1+(k-1)*M^2/2)^(-1/(k-1))
Mcr=M*SQRT((k+1)/(2+(k-1)*M^2))
AAcr=((2/(k+1))*(1+0.5*(k-1)*M^2))^(0.5*(k+1)/(k-1))/M

```

Ma	Ma*	A/A*	P/P ₀	ρ/ρ ₀	T/T ₀
1.0	1.0000	1.0000	0.5283	0.6339	0.8333
1.5	1.3646	1.1762	0.2724	0.3950	0.6897
2.0	1.6330	1.6875	0.1278	0.2300	0.5556
2.5	1.8257	2.6367	0.0585	0.1317	0.4444
3.0	1.9640	4.2346	0.0272	0.0762	0.3571
3.5	2.0642	6.7896	0.0131	0.0452	0.2899
4.0	2.1381	10.7188	0.0066	0.0277	0.2381
4.5	2.1936	16.5622	0.0035	0.0174	0.1980
5.0	2.2361	25.0000	0.0019	0.0113	0.1667
5.5	2.2691	36.8690	0.0011	0.0076	0.1418
6.0	2.2953	53.1798	0.0006	0.0052	0.1220
6.5	2.3163	75.1343	0.0004	0.0036	0.1058
7.0	2.3333	104.1429	0.0002	0.0026	0.0926
7.5	2.3474	141.8415	0.0002	0.0019	0.0816
8.0	2.3591	190.1094	0.0001	0.0014	0.0725
8.5	2.3689	251.0862	0.0001	0.0011	0.0647
9.0	2.3772	327.1893	0.0000	0.0008	0.0581
9.5	2.3843	421.1314	0.0000	0.0006	0.0525
10.0	2.3905	535.9375	0.0000	0.0005	0.0476

Discussion The tabulated values are useful for quick calculations, but be careful – they apply only to one specific value of k , in this case $k = 1.4$.



17-153 Using the compressible flow relations, the one-dimensional compressible flow functions are to be evaluated and tabulated as in Table A-32 for methane.

Properties The specific heat ratio is given to be $k = 1.3$ for methane.

Analysis The compressible flow functions listed below are expressed in EES and the results are tabulated.

$$\text{Ma}^* = \text{Ma} \sqrt{\frac{k+1}{2+(k-1)\text{Ma}^2}}$$

$$\frac{A}{A^*} = \frac{1}{\text{Ma}} \left[\left(\frac{2}{k+1} \right) \left(1 + \frac{k-1}{2} \text{Ma}^2 \right) \right]^{0.5(k+1)/(k-1)}$$

$$\frac{P}{P_0} = \left(1 + \frac{k-1}{2} \text{Ma}^2 \right)^{-k/(k-1)}$$

$$\frac{\rho}{\rho_0} = \left(1 + \frac{k-1}{2} \text{Ma}^2 \right)^{-1/(k-1)}$$

$$\frac{T}{T_0} = \left(1 + \frac{k-1}{2} \text{Ma}^2 \right)^{-1}$$

Methane:

```

k=1.3
PP0=(1+(k-1)*M^2/2)^(-k/(k-1))
TT0=1/(1+(k-1)*M^2/2)
DD0=(1+(k-1)*M^2/2)^(-1/(k-1))
Mcr=M*SQRT((k+1)/(2+(k-1)*M^2))
AAcr=((2/(k+1))*(1+0.5*(k-1)*M^2))^(0.5*(k+1)/(k-1))/M

```

Ma	Ma*	A/A*	P/P ₀	ρ/ρ ₀	T/T ₀
1.0	1.0000	1.0000	0.5457	0.6276	0.8696
1.5	1.3909	1.1895	0.2836	0.3793	0.7477
2.0	1.6956	1.7732	0.1305	0.2087	0.6250
2.5	1.9261	2.9545	0.0569	0.1103	0.5161
3.0	2.0986	5.1598	0.0247	0.0580	0.4255
3.5	2.2282	9.1098	0.0109	0.0309	0.3524
4.0	2.3263	15.9441	0.0050	0.0169	0.2941
4.5	2.4016	27.3870	0.0024	0.0095	0.2477
5.0	2.4602	45.9565	0.0012	0.0056	0.2105
5.5	2.5064	75.2197	0.0006	0.0033	0.1806
6.0	2.5434	120.0965	0.0003	0.0021	0.1563
6.5	2.5733	187.2173	0.0002	0.0013	0.1363
7.0	2.5978	285.3372	0.0001	0.0008	0.1198
7.5	2.6181	425.8095	0.0001	0.0006	0.1060
8.0	2.6350	623.1235	0.0000	0.0004	0.0943
8.5	2.6493	895.5077	0.0000	0.0003	0.0845
9.0	2.6615	1265.6040	0.0000	0.0002	0.0760
9.5	2.6719	1761.2133	0.0000	0.0001	0.0688
10.0	2.6810	2416.1184	0.0000	0.0001	0.0625

Discussion The tabulated values are useful for quick calculations, but be careful – they apply only to one specific value of k , in this case $k = 1.3$.

Fundamentals of Engineering (FE) Exam Problems

17-154 An aircraft is cruising in still air at 5°C at a velocity of 400 m/s. The air temperature at the nose of the aircraft where stagnation occurs is

- (a) 5°C (b) 25°C (c) 55°C (d) 80°C (e) 85°C

Answer (e) 85°C

Solution Solved by EES Software. Solutions can be verified by copying-and-pasting the following lines on a blank EES screen. (Similar problems and their solutions can be obtained easily by modifying numerical values).

```
T1=5 [C]
Vel1= 400 [m/s]
k=1.4
Cp=1.005 [kJ/kg-K]
T1_stag=T1+Vel1^2/(2*Cp*1000)
```

"Some Wrong Solutions with Common Mistakes:"

```
W1_Tstag=T1 "Assuming temperature rise"
W2_Tstag=Vel1^2/(2*Cp*1000) "Using just the dynamic temperature"
W3_Tstag=T1+Vel1^2/(Cp*1000) "Not using the factor 2"
```

17-155 Air is flowing in a wind tunnel at 25°C, 80 kPa, and 250 m/s. The stagnation pressure at a probe inserted into the flow stream is

- (a) 87 kPa (b) 96 kPa (c) 113 kPa (d) 119 kPa (e) 125 kPa

Answer (c) 96 kPa

Solution Solved by EES Software. Solutions can be verified by copying-and-pasting the following lines on a blank EES screen. (Similar problems and their solutions can be obtained easily by modifying numerical values).

```
T1=(25+273) [K]
P1=80 [kPa]
Vel1= 250 [m/s]

k=1.4
Cp=1.005 [kJ/kg-K]
T1_stag=(T1+273)+Vel1^2/(2*Cp*1000)
T1_stag/(T1+273)=(P1_stag/P1)^((k-1)/k)
```

"Some Wrong Solutions with Common Mistakes:"

```
T11_stag/T1=(W1_P1stag/P1)^((k-1)/k); T11_stag=T1+Vel1^2/(2*Cp*1000) "Using deg. C for temperatures"
T12_stag/(T1+273)=(W2_P1stag/P1)^((k-1)/k); T12_stag=(T1+273)+Vel1^2/(Cp*1000) "Not using the factor 2"
T13_stag/(T1+273)=(W3_P1stag/P1)^(k-1); T13_stag=(T1+273)+Vel1^2/(2*Cp*1000) "Using wrong isentropic relation"
```

17-156 An aircraft is reported to be cruising in still air at -20°C and 40 kPa at a Mach number of 0.86. The velocity of the aircraft is

- (a) 91 m/s (b) 220 m/s (c) 186 m/s (d) 274 m/s (e) 378 m/s

Answer (d) 274 m/s

Solution Solved by EES Software. Solutions can be verified by copying-and-pasting the following lines on a blank EES screen. (Similar problems and their solutions can be obtained easily by modifying numerical values).

```
T1=(-20+273) [K]
P1=40 [kPa]
Mach=0.86
k=1.4
Cp=1.005 [kJ/kg-K]
R=0.287 [kJ/kg-K]
VS1=SQRT(k*R*T1*1000)
Mach=Vel1/VS1
```

"Some Wrong Solutions with Common Mistakes:"

```
W1_vel=Mach*VS2; VS2=SQRT(k*R*T1) "Not using the factor 1000"
W2_vel=VS1/Mach "Using Mach number relation backwards"
W3_vel=Mach*VS3; VS3=k*R*T1 "Using wrong relation"
```

17-157 Air is flowing in a wind tunnel at 12°C and 66 kPa at a velocity of 230 m/s. The Mach number of the flow is

- (a) 0.54 (b) 0.87 (c) 3.3 (d) 0.36 (e) 0.68

Answer (e) 0.68

Solution Solved by EES Software. Solutions can be verified by copying-and-pasting the following lines on a blank EES screen. (Similar problems and their solutions can be obtained easily by modifying numerical values).

```
T1=(12+273) [K]
P1=66 [kPa]
Vel1=230 [m/s]

k=1.4
Cp=1.005 [kJ/kg-K]
R=0.287 [kJ/kg-K]
VS1=SQRT(k*R*T1*1000)
Mach=Vel1/VS1
```

"Some Wrong Solutions with Common Mistakes:"

```
W1_Mach=Vel1/VS2; VS2=SQRT(k*R*(T1-273)*1000) "Using C for temperature"
W2_Mach=VS1/Vel1 "Using Mach number relation backwards"
W3_Mach=Vel1/VS3; VS3=k*R*T1 "Using wrong relation"
```

17-158 Consider a converging nozzle with a low velocity at the inlet and sonic velocity at the exit plane. Now the nozzle exit diameter is reduced by half while the nozzle inlet temperature and pressure are maintained the same. The nozzle exit velocity will

- (a) remain the same (b) double (c) quadruple (d) go down by half (e) go down to one-fourth

Answer (a) remain the same

17-159 Air is approaching a converging-diverging nozzle with a low velocity at 12°C and 200 kPa, and it leaves the nozzle at a supersonic velocity. The velocity of air at the throat of the nozzle is

- (a) 338 m/s (b) 309 m/s (c) 280 m/s (d) 256 m/s (e) 95 m/s

Answer (b) 309 m/s

Solution Solved by EES Software. Solutions can be verified by copying-and-pasting the following lines on a blank EES screen. (Similar problems and their solutions can be obtained easily by modifying numerical values).

```
T1=(12+273) [K]
P1=200 [kPa]
Vel1=0 [m/s]
```

```
k=1.4
```

```
Cp=1.005 [kJ/kg-K]
```

```
R=0.287 [kJ/kg-K]
```

```
"Properties at the inlet"
```

```
To=T1 "since velocity is zero"
```

```
Po=P1
```

```
"Throat properties"
```

```
T_throat=2*To/(k+1)
```

```
P_throat=Po*(2/(k+1))^(k/(k-1))
```

```
"The velocity at the throat is the velocity of sound,"
```

```
V_throat=SQRT(k*R*T_throat*1000)
```

```
"Some Wrong Solutions with Common Mistakes:"
```

```
W1_Vthroat=SQRT(k*R*T1*1000) "Using T1 for temperature"
```

```
W2_Vthroat=SQRT(k*R*T2_throat*1000); T2_throat=2*(To-273)/(k+1) "Using C for temperature"
```

```
W3_Vthroat=k*R*T_throat "Using wrong relation"
```

17-160 Argon gas is approaching a converging-diverging nozzle with a low velocity at 20°C and 120 kPa, and it leaves the nozzle at a supersonic velocity. If the cross-sectional area of the throat is 0.015 m², the mass flow rate of argon through the nozzle is

- (a) 0.41 kg/s (b) 3.4 kg/s (c) 5.3 kg/s (d) 17 kg/s (e) 22 kg/s

Answer (c) 5.3 kg/s

Solution Solved by EES Software. Solutions can be verified by copying-and-pasting the following lines on a blank EES screen. (Similar problems and their solutions can be obtained easily by modifying numerical values).

```
T1=(20+273) [K]
P1=120 [kPa]
Vel1=0 [m/s]
A=0.015 [m^2]
```

```
k=1.667
Cp=0.5203 [kJ/kg-K]
R=0.2081 [kJ/kg-K]
"Properties at the inlet"
To=T1 "since velocity is zero"
Po=P1
```

```
"Throat properties"
T_throat=2*To/(k+1)
P_throat=Po*(2/(k+1))^(k/(k-1))
rho_throat=P_throat/(R*T_throat)
"The velocity at the throat is the velocity of sound,"
V_throat=SQRT(k*R*T_throat*1000)
m=rho_throat*A*V_throat
```

"Some Wrong Solutions with Common Mistakes:"

```
W1_mass=rho_throat*A*V1_throat; V1_throat=SQRT(k*R*T1_throat*1000); T1_throat=2*(To-273)/(k+1) "Using
C for temp"
W2_mass=rho2_throat*A*V_throat; rho2_throat=P1/(R*T1) "Using density at inlet"
```

17-161 Carbon dioxide enters a converging-diverging nozzle at 60 m/s, 310°C, and 300 kPa, and it leaves the nozzle at a supersonic velocity. The velocity of carbon dioxide at the throat of the nozzle is

- (a) 125 m/s (b) 225 m/s (c) 312 m/s (d) 353 m/s (e) 377 m/s

Answer (d) 353 m/s

Solution Solved by EES Software. Solutions can be verified by copying-and-pasting the following lines on a blank EES screen. (Similar problems and their solutions can be obtained easily by modifying numerical values).

```
T1=(310+273) [K]
P1=300 [kPa]
Vel1=60 [m/s]
```

```
k=1.289
```

```
Cp=0.846 [kJ/kg-K]
```

```
R=0.1889 [kJ/kg-K]
```

```
"Properties at the inlet"
```

```
To=T1+Vel1^2/(2*Cp*1000)
```

```
To/T1=(Po/P1)^(k-1)/k
```

```
"Throat properties"
```

```
T_throat=2*To/(k+1)
```

```
P_throat=Po*(2/(k+1))^(k/(k-1))
```

```
"The velocity at the throat is the velocity of sound,"
```

```
V_throat=SQRT(k*R*T_throat*1000)
```

```
"Some Wrong Solutions with Common Mistakes:"
```

```
W1_Vthroat=SQRT(k*R*T1*1000) "Using T1 for temperature"
```

```
W2_Vthroat=SQRT(k*R*T2_throat*1000); T2_throat=2*(T_throat-273)/(k+1) "Using C for temperature"
```

```
W3_Vthroat=k*R*T_throat "Using wrong relation"
```

17-162 Consider gas flow through a converging-diverging nozzle. Of the five statements below, select the one that is incorrect:

- (a) The fluid velocity at the throat can never exceed the speed of sound.
 (b) If the fluid velocity at the throat is below the speed of sound, the diversion section will act like a diffuser.
 (c) If the fluid enters the diverging section with a Mach number greater than one, the flow at the nozzle exit will be supersonic.
 (d) There will be no flow through the nozzle if the back pressure equals the stagnation pressure.
 (e) The fluid velocity decreases, the entropy increases, and stagnation enthalpy remains constant during flow through a normal shock.

Answer (c) If the fluid enters the diverging section with a Mach number greater than one, the flow at the nozzle exit will be supersonic.

17-163 Combustion gases with $k = 1.33$ enter a converging nozzle at stagnation temperature and pressure of 350°C and 400 kPa, and are discharged into the atmospheric air at 20°C and 100 kPa. The lowest pressure that will occur within the nozzle is

- (a) 13 kPa (b) 100 kPa (c) 216 kPa (d) 290 kPa (e) 315 kPa

Answer (c) 216 kPa

Solution Solved by EES Software. Solutions can be verified by copying-and-pasting the following lines on a blank EES screen. (Similar problems and their solutions can be obtained easily by modifying numerical values).

$k=1.33$
 $Po=400$ [kPa]

"The critical pressure is"

$P_throat=Po*(2/(k+1))^(k/(k-1))$

"The lowest pressure that will occur in the nozzle is the higher of the critical or atmospheric pressure."

"Some Wrong Solutions with Common Mistakes:"

$W2_Pthroat=Po*(1/(k+1))^(k/(k-1))$ "Using wrong relation"

$W3_Pthroat=100$ "Assuming atmospheric pressure"

17-164 ... 17-166 Design and Essay Problems



Solutions Manual for
Thermodynamics: An Engineering Approach
8th Edition
Yunus A. Çengel, Michael A. Boles
McGraw-Hill, 2015

Chapter 18

RENEWABLE ENERGY

PROPRIETARY AND CONFIDENTIAL

This Manual is the proprietary property of McGraw-Hill Education and protected by copyright and other state and federal laws. By opening and using this Manual the user agrees to the following restrictions, and if the recipient does not agree to these restrictions, the Manual should be promptly returned unopened to McGraw-Hill Education: **This Manual is being provided only to authorized professors and instructors for use in preparing for the classes using the affiliated textbook. No other use or distribution of this Manual is permitted. This Manual may not be sold and may not be distributed to or used by any student or other third party. No part of this Manual may be reproduced, displayed or distributed in any form or by any means, electronic or otherwise, without the prior written permission of McGraw-Hill Education.**

Introduction

18-1C The concern over the depletion of fossil fuels and pollutant and greenhouse emissions associated by their combustion can be tackled by essentially two methods: (i) Using renewable energy sources to replace fossil fuels. (ii) Implementing energy efficiency practices in all aspects of energy production, distribution, and consumption so that less fuel is used while obtaining the same useful output.

18-2C Main renewable energy sources include *solar*, *wind*, *hydropower*, *geothermal*, and *biomass*. Ocean, wave, and tidal energies are also renewable sources but they are currently not economical and the technologies are still in the experimental stage.

18-3C Although solar energy is sufficient to meet the entire energy needs of the world, currently it is not economical to do so because of the *low concentration* of solar energy on earth and the *high capital cost* of harnessing it.

18-4C *Wind* is the fastest growing renewable. *Hydropower* represents the greatest amount of electricity production among renewable.

18-5C We do not agree. The electricity used by the electric cars is generated somewhere else mostly by burning fuel and thus emitting pollution. Therefore, each time an electric car consumes 1 kWh of electricity, it bears the responsibility for the pollution s emitted as 1 kWh of electricity (plus the conversion and transmission losses) is generated elsewhere. The electric cars can be claimed to be zero emission vehicles only when the electricity they consume is generated by emission-free renewable resources such as hydroelectric, solar, wind, and geothermal energy.

Solar Energy

18-6C The conversion of solar energy into other useful forms of energy can be accomplished by three conversion processes. These are *heliothermal* process, *heliothermal* process, and *helioelectrical* process.

18-7C Solar energy is converted to electricity directly in solar cells while it is first converted to thermal energy in heliostats. Heliostats are mirrors that reflect solar radiation into a single receiver. The resulting high temperature thermal energy is converted to electricity by a heat engine.

18-8C Solar energy can be used for cooling applications in summer by absorption cooling systems but they are complex devices involving high initial costs.

18-9C Solar radiation falls in ultraviolet, visible, and infrared regions of spectrum. Most radiation falls in near-infrared region.

18-10C When solar radiation strikes a surface, part of it is absorbed, part of it is reflected, and the remaining part, if any, is transmitted. The *transmissivity* τ , the *reflectivity* ρ , and the *absorptivity* α of a surface for solar energy are the fractions of incident solar radiation transmitted, reflected, and absorbed, respectively. For an opaque surface,

$$\tau = 0 \quad \text{and} \quad \alpha + \rho = 1$$

18-11C Most solar collectors in operation today are used to produce hot water.

18-12C A *thermosyphon solar water heater system* operates on a natural circulation. Water flows through the system when warm water rises into the tank as cooler water sinks. An *active, closed loop solar water heater* uses a pump for the circulation of water containing antifreeze fluid.

18-13C A solar hot water collector may be equipped with an *electric resistance heater* to provide hot water when solar energy is not available. A *backup water heater* that runs on natural gas or another fuel may also be used.

18-14C The efficiency of a flat-plate solar collector is given by

$$\eta_c = \tau\alpha - U \frac{T_c - T_a}{G}$$

The efficiency of a solar collector is maximized when the temperature difference between the collector temperature and the air temperature $T_c - T_a$ is zero. In this case, the efficiency is equal to $\tau\alpha$. An unglazed collector has the highest maximum efficiency as it has the highest value of $\tau\alpha$ values. This is followed by the single-glazing and double-glazing collectors.

18-15C The concentration of solar energy is low, and as a result, the temperature of hot water obtainable in a flat-plate collector is low (usually under 80°C). Hot fluid (water, steam, air, or another fluid) at much higher temperatures can be produced using concentrating collectors by concentrating solar radiation on a smaller area. Temperatures in the receiver of a concentrating collector can reach 400°C.

18-16C The efficiency of a solar system used to produce electricity may be defined as the power produced divided by the total solar irradiation. That is,

$$\eta_{\text{th,solar}} = \frac{\dot{W}_{\text{out}}}{\dot{Q}_{\text{incident}}} = \frac{\dot{W}_{\text{out}}}{A_c G}$$

where A_c is the collector surface area receiving solar irradiation and G is the solar irradiation.

18-17C A promising method of power generation involves collecting and storing solar energy in large artificial lakes a few meters deep, called *solar ponds*. Solar energy is absorbed by all parts of the pond, and the water temperature rises everywhere. The top part of the pond, however, loses to the atmosphere much of the heat it absorbs, and as a result, its temperature drops. This cool water serves as insulation for the bottom part of the pond and helps trap the energy there. Usually, salt is planted at the bottom of the pond to prevent the rise of this hot water to the top. A power plant that uses an organic fluid, such as alcohol, as the working fluid can be operated between the top and the bottom portions of the pond. The main disadvantage of solar pond power plant is the low thermal efficiency.

18-18C An *ocean thermal energy converter* (OTEC) system uses the same principle as a solar pond system but in this case the water at the sea or ocean surface is warmer as a result of solar energy absorption. The water at a deeper location is cooler. Then, a heat engine can be operated that utilizes the surface warm water as heat source and deep cold water as the heat sink. Experiments have been performed for OTEC principle but the results have not been promising due to large installation cost and low thermal efficiency.

18-19C The *current density* J is defined as the current I over the cell surface area A . The current density flow from n -type semiconductor to p -type semiconductor is denoted by J_r , and called the *light-induced recombination current* and that from p -type to n -type is denoted by J_o , and called the *dark current* or *reverse saturation current*.

18-20C A photovoltaic system typically consists *arrays*, which are obtained by connecting *modules* and modules consists of individual *cells*.

18-21C A house should be designed to receive (a) maximum solar heat in winter (to reduce heating energy consumption) in winter-dominated climates and (b) minimum solar heat gain in summer (to reduce cooling energy consumption) in summer-dominated climates.

18-22C Dark painted thick masonry walls called *trombe walls* are commonly used on south sides of passive solar homes to absorb solar energy, store it during the day, and release it to the house during the night. The use of trombe wall reduces the heating energy consumption of the building in winter.

12-23C (a) The spectral distribution of solar radiation beyond the earth's atmosphere resembles the energy emitted by a black body at 5982°C, with about 39 percent in the visible region (0.4 to 0.7 μm), and the 52 percent in the near infrared region (0.7 to 3.5 μm). (b) At a solar altitude of 41.8°, the total energy of direct solar radiation incident at sea level on a clear day consists of about 3 percent ultraviolet, 38 percent visible, and 59 percent infrared radiation.

12-24C A device that blocks solar radiation and thus reduces the solar heat gain is called a shading device. External shading devices are more effective in reducing the solar heat gain since they intercept sun's rays before they reach the glazing. The solar heat gain through a window can be reduced by as much as 80 percent by exterior shading. *Light colored* shading devices maximize the back reflection and thus minimize the solar gain. *Dark colored* shades, on the other hand, minimize the back reflection and thus maximize the solar heat gain.

12-25C The **solar heat gain coefficient (SHGC)** is defined as the fraction of incident solar radiation that enters through the glazing. The solar heat gain of a glazing relative to the solar heat gain of a reference glazing, typically that of a standard 3 mm (1/8 in) thick double-strength clear window glass sheet whose SHGC is 0.87, is called the **shading coefficient**. They are related to each other by

$$SC = \frac{\text{Solar heat gain of product}}{\text{Solar heat gain of reference glazing}} = \frac{SHGC}{SHGC_{ref}} = \frac{SHGC}{0.87} = 1.15 \times SHGC$$

For single pane clear glass window, SHGC = 0.87 and SC = 1.0.

12-26C The SC (shading coefficient) of a device represents the solar heat gain relative to the solar heat gain of a reference glazing, typically that of a standard 3 mm (1/8 in) thick double-strength clear window glass sheet whose SHGC is 0.87. The shading coefficient of a 3-mm thick *clear glass* is SC = 1.0 whereas SC = 0.88 for 3-mm thick *heat absorbing glass*.

12-27C A window that transmits visible part of the spectrum while absorbing the infrared portion is ideally suited for minimizing the air-conditioning load since such windows provide maximum daylighting and minimum solar heat gain. The ordinary window glass approximates this behavior remarkably well.

12-28C A low-e coating on the inner surface of a window glass reduces both the (a) heat loss in winter and (b) heat gain in summer. This is because the radiation heat transfer to or from the window is proportional to the emissivity of the inner surface of the window. In winter, the window is colder and thus radiation heat loss from the room to the window is low. In summer, the window is hotter and the radiation transfer from the window to the room is low.

18-29 The transmissivity of the glazing and the absorptivity of the absorber plate for a flat-plate solar collector are given. The maximum efficiency of the collector is to be determined.

Properties The transmissivity of glazing and the absorptivity of absorber plate are given in the problem statement.

Analysis The efficiency of a solar collector is defined as

$$\eta_c = \frac{\dot{Q}_{\text{useful}}}{\dot{Q}_{\text{incident}}} = \frac{\tau\alpha AG - UA(T_c - T_a)}{AG} = \tau\alpha - U \frac{T_c - T_a}{G}$$

The collector efficiency is maximum when the collector temperature is equal to the air temperature $T_c = T_a$ and thus $T_c - T_a = 0$. Therefore,

$$\eta_{c,\text{max}} = \tau\alpha = (0.82)(0.94) = 0.771 = \mathbf{77.1\text{percent}}$$

That is, the maximum efficiency of this collector is 77.1 percent.

18-30 The characteristics of a flat-plate solar collector and the rate of radiation incident are given. The collector efficiency is to be determined.

Properties The transmissivity of glazing and the absorptivity of absorber plate are given in the problem statement.

Analysis The efficiency of this solar collector is determined from

$$\begin{aligned} \eta_c &= \tau\alpha - U \frac{T_c - T_a}{G} \\ &= (0.86)(0.95) - (3 \text{ W/m}^2 \cdot \text{°C}) \frac{(45 - 23) \text{°C}}{750 \text{ W/m}^2} \\ &= 0.729 = \mathbf{72.9\text{percent}} \end{aligned}$$

That is, the efficiency of this collector is 72.9 percent.

18-31E The characteristics of a flat-plate solar collector and the rate of solar radiation incident are given. The collector efficiency is to be determined.

Properties The product of transmissivity of glazing and the absorptivity of absorber plate is given in the problem statement.

Analysis (a) The efficiency of single-glazing solar collector is determined from

$$\begin{aligned}\eta_c &= \tau\alpha - U \frac{T_c - T_a}{G} \\ &= (0.85) - (0.5 \text{ Btu/h} \cdot \text{ft}^2 \cdot ^\circ\text{F}) \frac{(120 - 67)^\circ\text{F}}{260 \text{ Btu/h} \cdot \text{ft}^2} \\ &= 0.748 = \mathbf{74.8\text{percent}}\end{aligned}$$

(b) The efficiency of double-glazing solar collector is determined similarly as

$$\begin{aligned}\eta_c &= \tau\alpha - U \frac{T_c - T_a}{G} \\ &= (0.80) - (0.3 \text{ Btu/h} \cdot \text{ft}^2 \cdot ^\circ\text{F}) \frac{(120 - 67)^\circ\text{F}}{260 \text{ Btu/h} \cdot \text{ft}^2} \\ &= 0.739 = \mathbf{73.9\text{percent}}\end{aligned}$$

The efficiency of single-glazing collector is slightly greater than that of double-glazing collector.

18-32 A flat-plate solar collector is used to produce hot water. The characteristics of a flat-plate solar collector and the rate of radiation incident are given. The temperature of hot water provided by the collector is to be determined.

Properties The product of transmissivity of glazing and the absorptivity of absorber plate is given in the problem statement. The density of water is 1000 kg/m^3 and its specific heat is $4.18 \text{ kJ/kg} \cdot ^\circ\text{C}$.

Analysis The total rate of solar radiation incident on the collector is

$$\dot{Q}_{\text{incident}} = AG = (33 \text{ m}^2)(880 \text{ W/m}^2) = 29,040 \text{ W}$$

The mass flow rate of water is

$$\dot{m} = \rho \dot{V} = (1 \text{ L/kg})(6.3/60 \text{ L/s}) = 0.105 \text{ kg/s}$$

The rate of useful heat transferred to the water is determined from the definition of collector efficiency to be

$$\eta_c = \frac{\dot{Q}_{\text{useful}}}{\dot{Q}_{\text{incident}}} \longrightarrow \dot{Q}_{\text{useful}} = \eta_c \dot{Q}_{\text{incident}} = (0.70)(29,040 \text{ W}) = 20,328 \text{ W}$$

Then the temperature of hot water provided by the collector is determined from

$$\begin{aligned}\dot{Q}_{\text{useful}} &= \dot{m}c_p(T_{w,\text{out}} - T_{w,\text{in}}) \\ 20,328 \text{ W} &= (0.105 \text{ kg/s})(4.28 \text{ kJ/kg} \cdot ^\circ\text{C})(T_{w,\text{out}} - 18)^\circ\text{C} \\ T_{w,\text{out}} &= \mathbf{64.3^\circ\text{C}}\end{aligned}$$

That is, this collector is supplying water at 64.3°C .

18-33E A flat-plate solar collector is considered. The collector efficiency for a given water inlet temperature and the water temperature for a collector efficiency of zero are to be determined.

Properties The transmissivity of glazing and the absorptivity of absorber plate are given in the problem statement.

Analysis (a) The efficiency of single-glazing solar collector is determined from

$$\begin{aligned}\eta_c &= F_R K_{\tau\alpha} \tau\alpha - F_R U \frac{T_{w,in} - T_a}{G} \\ &= (0.92)(1)(0.88)(0.97) - (0.92)(1.3 \text{ Btu/h} \cdot \text{ft}^2 \cdot ^\circ\text{F}) \frac{(115 - 60)^\circ\text{F}}{210 \text{ Btu/h} \cdot \text{ft}^2} \\ &= 0.472 = \mathbf{47.2\text{percent}}\end{aligned}$$

(b) Setting the collector efficiency zero in the efficiency relation gives

$$\begin{aligned}F_R K_{\tau\alpha} \tau\alpha - F_R U \frac{T_{w,in} - T_a}{G} &= 0 \\ F_R K_{\tau\alpha} \tau\alpha &= F_R U \frac{T_{w,in} - T_a}{G} \\ (0.92)(1)(0.88)(0.97) &= (0.92)(1.3 \text{ Btu/h} \cdot \text{ft}^2 \cdot ^\circ\text{F}) \frac{(T_{w,in} - 60)^\circ\text{F}}{210 \text{ Btu/h} \cdot \text{ft}^2} = 0 \\ T_{w,in} &= \mathbf{198^\circ\text{F}}\end{aligned}$$

18-34 The characteristics of a concentrating solar collector are given. The collector efficiency is to be determined.

Analysis The efficiency of this solar collector is determined from

$$\begin{aligned}\eta_c &= \eta_{ar} - U \frac{T_c - T_a}{\text{CR} \times G} = 0.93 - (4 \text{ W/m}^2 \cdot ^\circ\text{C}) \frac{(130 - 20)^\circ\text{C}}{(15)(520 \text{ W/m}^2)} \\ &= 0.874 = \mathbf{87.4\text{percent}}\end{aligned}$$

That is, the efficiency of this collector is 87.4 percent.

18-35 A solar power plant utilizing parabolic trough collectors is considered. The power generated is to be determined.

Analysis The efficiency of a solar power plant is defined as the power produced divided by the total solar irradiation. That is,

$$\eta_{\text{th,solar}} = \frac{\dot{W}_{\text{out}}}{\dot{Q}_{\text{incident}}} = \frac{\dot{W}_{\text{out}}}{A_c G}$$

Solving for the power output,

$$\dot{W}_{\text{out}} = \eta_{\text{th,solar}} A_c G = (0.08)(2500 \text{ m}^2)(0.700 \text{ kW/m}^2) = \mathbf{140 \text{ kW}}$$

18-36 A solar pond power plant with specified temperatures and thermal efficiency is considered. The second-law efficiency of the power plant power is to be determined.

Analysis The maximum thermal efficiency of this power plant is equal to Carnot efficiency, and is determined from

$$\eta_{\text{th,max}} = 1 - \frac{T_L}{T_H} = 1 - \frac{(30 + 273) \text{ K}}{(75 + 273) \text{ K}} = 0.1293$$

The second-law efficiency is the ratio of actual thermal efficiency to the maximum thermal efficiency:

$$\eta_{\text{II}} = \frac{\eta_{\text{th}}}{\eta_{\text{th,max}}} = \frac{0.036}{0.1293} = 0.278 = \mathbf{27.8\text{percent}}$$

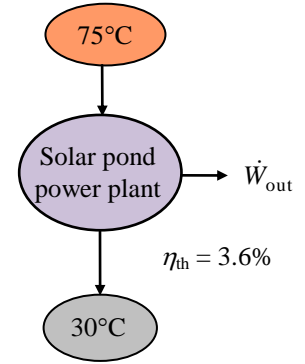

18-37 A solar-power-tower plant is considered. The power output and thermal efficiency of the plant, the annual electricity production, and the cost of the plant are to be determined.

Assumptions 1 Steady operating conditions exist. 2 Kinetic and potential energy changes are negligible.

Analysis (a) Using the turbine isentropic efficiency, the steam properties at the inlet and exit of the turbine are determined as follows: (Tables A-4E, A-5E, and A-6E),

$$\begin{aligned} P_1 = 160 \text{ psia} & \left. \begin{array}{l} h_1 = 1325.2 \text{ Btu/lbm} \\ T_1 = 600^\circ\text{F} \end{array} \right\} s_1 = 1.7037 \text{ Btu/lbm} \cdot \text{R} \\ P_2 = 2 \text{ psia} & \left. \begin{array}{l} h_{2s} = 989.43 \text{ Btu/lbm} \\ s_2 = s_1 \end{array} \right\} \\ \eta_T = \frac{h_1 - h_2}{h_1 - h_{2s}} & \longrightarrow h_2 = h_1 - \eta_T (h_1 - h_{2s}) \\ & = 1325.2 - (0.88)(1325.2 - 989.43) = 1029.7 \text{ Btu/lbm} \end{aligned}$$

Then the power output is

$$\begin{aligned} \dot{W}_{\text{out}} &= \dot{m}(h_1 - h_2) = (15 \times 3600 \text{ lbm/h})(1325.2 - 1029.7) \text{ Btu/lbm} = 1.596 \times 10^7 \text{ Btu/h} \\ &= (1.596 \times 10^7 \text{ Btu/h}) \left(\frac{1 \text{ kW}}{3412.14 \text{ Btu/h}} \right) = \mathbf{4677 \text{ kW}} \end{aligned}$$

The thermal efficiency of this power plant is equal to power output divided by the total solar incident on the heliostats:

$$\eta_{\text{th}} = \frac{\dot{W}_{\text{out}}}{AG} = \frac{1.596 \times 10^7 \text{ Btu/h}}{(400,000 \text{ ft}^2)(250 \text{ Btu/h} \cdot \text{ft}^2)} = 0.1596 = \mathbf{16.0\%}$$

(b) The solar data for Houston, Texas is given in Table 18-4. The daily average solar irradiation for an entire year on a horizontal surface is given to be $15.90 \text{ MJ/m}^2 \cdot \text{day}$. Multiplying this value with 365 days of the year gives an estimate of total solar irradiation on the heliostat surfaces. Using the definition of the thermal efficiency,

$$\begin{aligned} W_{\text{out}} &= \eta_{\text{th,avg}} AG \\ &= (0.12)(400,000 \text{ ft}^2)(15,900 \text{ kJ/m}^2 \cdot \text{day})(365 \text{ days}) \left(\frac{1 \text{ kWh}}{3600 \text{ kJ}} \right) \left(\frac{1 \text{ m}^2}{10.764 \text{ ft}^2} \right) \\ &= 7.189 \times 10^6 \text{ kWh} \end{aligned}$$

This is total power output from the turbine. The electrical energy output from the generator is

$$W_{\text{elect}} = \eta_{\text{gen}} W_{\text{out}} = (0.98)(7.189 \times 10^6 \text{ kWh}) = \mathbf{7.045 \times 10^6 \text{ kWh}}$$

(c) The total cost of this power plant is

$$\text{Plant cost} = \text{Unit cost} \times \dot{W}_{\text{out}} = (\$17,000/\text{kW})(4677 \text{ kW}) = \$7.949 \times 10^7$$

The annual revenue from selling the electricity produced is

$$\begin{aligned} \text{Annual revenue} &= \dot{W}_{\text{out}} \times \text{Unit price} \times \text{Operating hours} \\ &= (4677 \text{ kW})(\$0.11/\text{kW})(4500 \text{ h}) \\ &= \$2.315 \times 10^6/\text{year} \end{aligned}$$

The simple payback period is then

$$\text{Payback period} = \frac{\text{Plant cost}}{\text{Annual revenue}} = \frac{\$7.949 \times 10^7}{\$2.315 \times 10^6/\text{year}} = \mathbf{34.3 \text{ years}}$$

That is, this plant pays for itself in 34 years, which is not unexpected for solar power plants.

18-38 A solar cell with a specified value of open circuit voltage is considered. The current output density, the load voltage for maximum power output, and the maximum power output of the cell for a unit cell area are to be determined.

Analysis (a) The current output density is determined from Eq. 18-18 to be

$$V_{oc} = \frac{kT}{e_o} \ln\left(\frac{J_s}{J_o} + 1\right)$$

$$0.55 \text{ V} = \frac{(1.381 \times 10^{-23} \text{ J/K})(298 \text{ K})}{1.6 \times 10^{-19} \text{ J/V}} \ln\left(\frac{J_s}{1.9 \times 10^{-9} \text{ A/m}^2} + 1\right)$$

$$J_s = \mathbf{3.676 \text{ A/m}^2}$$

(b) The load voltage at which the power output is maximum is determined from Eq. 18-22 to be

$$\exp\left(\frac{e_o V_{\max}}{kT}\right) = \frac{1 + J_s / J_o}{1 + \frac{e_o V_{\max}}{kT}}$$

$$\exp\left(\frac{(1.6 \times 10^{-19} \text{ J/V})V_{\max}}{(1.381 \times 10^{-23} \text{ J/K})(298 \text{ K})}\right) = \frac{1 + (3.676 \text{ A/m}^2 / 1.9 \times 10^{-9} \text{ A/m}^2)}{1 + \frac{(1.6 \times 10^{-19} \text{ J/V})V_{\max}}{(1.381 \times 10^{-23} \text{ J/K})(298 \text{ K})}}$$

$$V_{\max} = \mathbf{0.4737 \text{ V}}$$

(c) The maximum power output of the cell for a unit cell area is determined from

$$\dot{W}_{\max} = \frac{V_{\max} (J_s + J_o)}{1 + \frac{kT}{e_o V_{\max}}} = \frac{(0.4737 \text{ V})(3.676 \text{ A/m}^2)(1.9 \times 10^{-9} \text{ A/m}^2)}{1 + \frac{(1.381 \times 10^{-23} \text{ J/K})(298 \text{ K})}{(1.6 \times 10^{-19} \text{ J/V})(0.4737 \text{ V})}} = \mathbf{1.652 \text{ W/m}^2}$$

18-39 A solar cell with a specified value of open circuit voltage is considered. The power output and the efficiency of the cell are to be determined.

Analysis The current output density is determined from Eq. 18-18 to be

$$V_{oc} = \frac{kT}{e_o} \ln \left(\frac{J_s}{J_o} + 1 \right)$$

$$0.60 \text{ V} = \frac{(1.381 \times 10^{-23} \text{ J/K})(300 \text{ K})}{1.6 \times 10^{-19} \text{ J/V}} \ln \left(\frac{J_s}{3.9 \times 10^{-9} \text{ A/m}^2} + 1 \right)$$

$$J_s = 45.12 \text{ A/m}^2$$

The power output is

$$\dot{W} = VAJ_s - VAJ_o \left[\exp \left(\frac{e_o V}{kT} \right) - 1 \right]$$

$$= (0.52 \text{ V})(28 \text{ m}^2)(45.12 \text{ A/m}^2) - (0.52 \text{ V})(28 \text{ m}^2)(3.9 \times 10^{-9} \text{ A/m}^2) \left[\exp \left(\frac{(1.6 \times 10^{-19} \text{ J/V})(0.52 \text{ V})}{(1.381 \times 10^{-23} \text{ J/K})(300 \text{ K})} \right) - 1 \right]$$

$$= \mathbf{627 \text{ W}}$$

The efficiency of the cell is

$$\eta_{th} = \frac{\dot{W}}{AG} = \frac{627 \text{ W}}{(28 \text{ m}^2)(485 \text{ W/m}^2)} = 0.0462 = \mathbf{4.62 \text{ percent}}$$

18-40E A solar cell with a specified value of open circuit voltage is considered. The load voltage for maximum power output, the efficiency of the cell, and the cell area for a given power output are to be determined.

Analysis (a) The current output density is determined from Eq. 18-18 to be

$$V_{oc} = \frac{kT}{e_o} \ln \left(\frac{J_s}{J_o} + 1 \right)$$

$$0.60 \text{ V} = \frac{(1.381 \times 10^{-23} \text{ J/K})[(75 - 32)/1.8 + 273.15] \text{ K}}{1.6 \times 10^{-19} \text{ J/V}} \ln \left(\frac{J_s}{4.11 \times 10^{-10} \text{ A/ft}^2 \left(\frac{10.764 \text{ ft}^2}{1 \text{ m}^2} \right)} + 1 \right)$$

$$J_s = 64.48 \text{ A/m}^2$$

The load voltage at which the power output is maximum is determined from Eq. 18-22 to be

$$\exp \left(\frac{e_o V_{\max}}{kT} \right) = \frac{1 + J_s / J_o}{1 + \frac{e_o V_{\max}}{kT}}$$

$$\exp \left(\frac{(1.6 \times 10^{-19} \text{ J/V}) V_{\max}}{(1.381 \times 10^{-23} \text{ J/K})[(75 - 32)/1.8 + 273.15] \text{ K}} \right) = \frac{1 + (64.48 \text{ A/m}^2) / \left[4.11 \times 10^{-10} \text{ A/ft}^2 \left(\frac{10.764 \text{ ft}^2}{1 \text{ m}^2} \right) \right]}{1 + \frac{(1.6 \times 10^{-19} \text{ J/V}) V_{\max}}{(1.381 \times 10^{-23} \text{ J/K})[(75 - 32)/1.8 + 273.15] \text{ K}}}$$

$$V_{\max} = \mathbf{0.5215 \text{ V}}$$

(b) The load current density J_L is determined from

$$J_L = J_s - J_j = J_s - J_o \left[\exp \left(\frac{e_o V}{kT} \right) - 1 \right]$$

$$= (64.48 \text{ A/m}^2) - \left[4.11 \times 10^{-10} \text{ A/ft}^2 \left(\frac{10.764 \text{ ft}^2}{1 \text{ m}^2} \right) \right] \exp \left[\left(\frac{(1.6 \times 10^{-19} \text{ J/V})(0.56 \text{ V})}{(1.381 \times 10^{-23} \text{ J/K})[(75 - 32)/1.8 + 273.15] \text{ K}} \right) - 1 \right]$$

$$= 50.93 \text{ A/m}^2$$

The power output is

$$\dot{W} = J_L V = (50.93 \text{ A/m}^2)(0.56 \text{ V}) = 28.52 \text{ W/m}^2$$

The efficiency of the cell is

$$\eta_{\text{th}} = \frac{\dot{W}}{G} = \frac{28.52 \text{ W/m}^2}{(220 \text{ Btu/h} \cdot \text{ft}^2) \left(\frac{1 \text{ W/m}^2}{0.3171 \text{ Btu/h} \cdot \text{ft}^2} \right)} = 0.0411 = \mathbf{4.11 \text{ percent}}$$

(c) Finally, the cell area for a power output of 500 W is

$$A = \frac{\dot{W}_{\text{total}}}{\dot{W}} = \frac{500 \text{ W}}{28.52 \text{ W/m}^2} \left(\frac{10.764 \text{ ft}^2}{1 \text{ m}^2} \right) = \mathbf{188.7 \text{ ft}^2}$$

18-41E A solar cell with a specified value of open circuit voltage is considered. The maximum conversion efficiency of the solar cell is to be determined.

Analysis The current output density is determined from Eq. 18-18 to be

$$V_{oc} = \frac{kT}{e_o} \ln \left(\frac{J_s}{J_o} + 1 \right)$$

$$0.60 \text{ V} = \frac{(1.381 \times 10^{-23} \text{ J/K})[(75 - 32)/1.8 + 273.15] \text{ K}}{1.6 \times 10^{-19} \text{ J/V}} \ln \left(\frac{J_s}{4.11 \times 10^{-10} \text{ A/ft}^2 \left(\frac{10.764 \text{ ft}^2}{1 \text{ m}^2} \right)} + 1 \right)$$

$$J_s = 64.48 \text{ A/m}^2$$

The load voltage at which the power output is maximum is determined from Eq. 18-22 to be

$$\exp \left(\frac{e_o V_{\max}}{kT} \right) = \frac{1 + J_s / J_o}{1 + \frac{e_o V_{\max}}{kT}}$$

$$\exp \left(\frac{(1.6 \times 10^{-19} \text{ J/V}) V_{\max}}{(1.381 \times 10^{-23} \text{ J/K})[(75 - 32)/1.8 + 273.15] \text{ K}} \right) = \frac{1 + (64.48 \text{ A/m}^2) / \left[4.11 \times 10^{-10} \text{ A/ft}^2 \left(\frac{10.764 \text{ ft}^2}{1 \text{ m}^2} \right) \right]}{1 + \frac{(1.6 \times 10^{-19} \text{ J/V}) V_{\max}}{(1.381 \times 10^{-23} \text{ J/K})[(75 - 32)/1.8 + 273.15] \text{ K}}}$$

$$V_{\max} = \mathbf{0.5215 \text{ V}}$$

The maximum conversion efficiency of this solar cell is determined from

$$\eta_{\text{cell,max}} = \frac{V_{\max} (J_s + J_o)}{G \left(1 + \frac{kT}{e_o V_{\max}} \right)}$$

$$= \frac{(0.5215 \text{ V})(64.48 \text{ A/m}^2) + \left[4.11 \times 10^{-10} \text{ A/ft}^2 \left(\frac{10.764 \text{ ft}^2}{1 \text{ m}^2} \right) \right]}{\left[(220 \text{ Btu/h} \cdot \text{ft}^2) \left(\frac{1 \text{ W/m}^2}{0.3171 \text{ Btu/h} \cdot \text{ft}^2} \right) \right] \left(1 + \frac{(1.381 \times 10^{-23} \text{ J/K})[(75 - 32)/1.8 + 273.15] \text{ K}}{(1.6 \times 10^{-19} \text{ J/V})(0.5215 \text{ V})} \right)}$$

$$= 0.04619 = \mathbf{4.62 \text{ percent}}$$

18-42 The thermal efficiency of a solar car using solar cells is to be determined.

Analysis The thermal efficiency of the solar car is determined from

$$\eta_{\text{th}} = \frac{\dot{W}}{AG} = \frac{540 \text{ W}}{(8 \text{ m}^2)(860 \text{ W/m}^2)} = 0.0785 = \mathbf{7.85 \text{ percent}}$$

18-43 A building located near 40° N latitude has equal window areas on all four sides. The side of the building with the highest solar heat gain in summer is to be determined.

Assumptions The shading coefficients of windows on all sides of the building are identical.

Analysis The reflective films should be installed on the side that receives the most incident solar radiation in summer since the window areas and the shading coefficients on all four sides are identical. The incident solar radiation at different windows in July are given to be (Table 18-3)

Month	Time	The daily total solar radiation incident on the surface, Wh/m ²			
		North	East	South	West
July	Daily total	1621	4313	2552	4313

Therefore, the reflective film should be installed on the **East** or **West** windows (instead of the South windows) in order to minimize the solar heat gain and thus the cooling load of the building.

18-44 The net annual cost savings due to installing reflective coating on the West windows of a building and the simple payback period are to be determined.

Assumptions 1 The calculations given below are for an average year. 2 The unit costs of electricity and natural gas remain constant.

Analysis Using the daily averages for each month and noting the number of days of each month, the total solar heat flux incident on the glazing during summer and winter months are determined to be

$$Q_{\text{solar, summer}} = 4.24 \times 30 + 4.16 \times 31 + 3.93 \times 31 + 3.48 \times 30 \\ = 482 \text{ kWh/year}$$

$$Q_{\text{solar, winter}} = 2.94 \times 31 + 2.33 \times 30 + 2.07 \times 31 + 2.35 \times 31 + 3.03 \times 28 + 3.62 \times 31 + 4.00 \times 30 \\ = 615 \text{ kWh/year}$$

Then the decrease in the annual cooling load and the increase in the annual heating load due to reflective film become

$$\text{Cooling load decrease} = Q_{\text{solar, summer}} A_{\text{glazing}} (\text{SHGC}_{\text{without film}} - \text{SHGC}_{\text{with film}}) \\ = (482 \text{ kWh/year})(60 \text{ m}^2)(0.766 - 0.35) \\ = 12,031 \text{ kWh/year}$$

$$\text{Heating load increase} = Q_{\text{solar, winter}} A_{\text{glazing}} (\text{SHGC}_{\text{without film}} - \text{SHGC}_{\text{with film}}) \\ = (615 \text{ kWh/year})(60 \text{ m}^2)(0.766 - 0.35) \\ = 15,350 \text{ kWh/year} = 523.7 \text{ therms/year}$$

since 1 therm = 29.31 kWh. The corresponding decrease in cooling costs and increase in heating costs are

$$\text{Decrease in cooling costs} = (\text{Cooling load decrease})(\text{Unit cost of electricity})/\text{COP} \\ = (12,031 \text{ kWh/year})(\$0.15/\text{kWh})/3.2 = \$564/\text{year}$$

$$\text{Increase in heating costs} = (\text{Heating load increase})(\text{Unit cost of fuel})/\text{Efficiency} \\ = (523.7 \text{ therms/year})(\$0.90/\text{therm})/0.90 = \$524/\text{year}$$

Then the net annual cost savings due to reflective films become

$$\text{Cost Savings} = \text{Decrease in cooling costs} - \text{Increase in heating costs} = \$564 - 524 = \mathbf{\$40/\text{year}}$$

The implementation cost of installing films is

$$\text{Implementation Cost} = (\$15/\text{m}^2)(60 \text{ m}^2) = \$900$$

This gives a simple payback period of

$$\text{Simple payback period} = \frac{\text{Implementation cost}}{\text{Annual cost savings}} = \frac{\$900}{\$40/\text{year}} = \mathbf{22.5 \text{ years}}$$

Discussion The reflective films will pay for themselves in this case in about 23 years, which is unacceptable to most manufacturers since they are not usually interested in any energy conservation measure which does not pay for itself within 3 years.

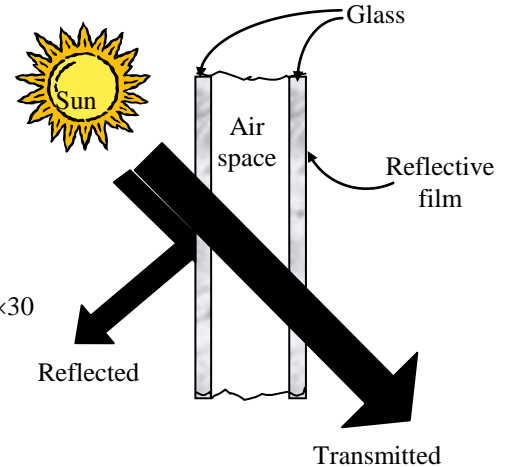

18-45 A house located at 40°N latitude has ordinary double pane windows. The total solar heat gain of the house at 9:00, 12:00, and 15:00 solar time in July and the total amount of solar heat gain per day for an average day in January are to be determined.

Assumptions The calculations are performed for an average day in a given month.

Properties The shading coefficient of a double pane window with 6-mm thick glasses is $SC = 0.82$ (Table 18-6). The incident radiation at different windows at different times are given as (Table 8-3)

Month	Time	Solar radiation incident on the surface, W/m^2			
		North	East	South	West
July	9:00	117	701	190	114
July	12:00	138	149	395	149
July	15:00	117	114	190	701
January	Daily total	446	1863	5897	1863

Analysis The solar heat gain coefficient (SHGC) of the windows is determined from Eq.12-57 to be

$$SHGC = 0.87 \times SC = 0.87 \times 0.82 = 0.7134$$

The rate of solar heat gain is determined from

$$\begin{aligned}\dot{Q}_{\text{solar gain}} &= SHGC \times A_{\text{glazing}} \times \dot{q}_{\text{solar, incident}} \\ &= 0.7134 \times A_{\text{glazing}} \times \dot{q}_{\text{solar, incident}}\end{aligned}$$

Then the rates of heat gain at the 4 walls at 3 different times in July become

North wall:

$$\begin{aligned}\dot{Q}_{\text{solar gain, 9:00}} &= 0.7134 \times (4 \text{ m}^2) \times (117 \text{ W/m}^2) = \mathbf{334 \text{ W}} \\ \dot{Q}_{\text{solar gain, 12:00}} &= 0.7134 \times (4 \text{ m}^2) \times (138 \text{ W/m}^2) = \mathbf{394 \text{ W}} \\ \dot{Q}_{\text{solar gain, 15:00}} &= 0.7134 \times (4 \text{ m}^2) \times (117 \text{ W/m}^2) = \mathbf{334 \text{ W}}\end{aligned}$$

East wall:

$$\begin{aligned}\dot{Q}_{\text{solar gain, 9:00}} &= 0.7134 \times (6 \text{ m}^2) \times (701 \text{ W/m}^2) = \mathbf{3001 \text{ W}} \\ \dot{Q}_{\text{solar gain, 12:00}} &= 0.7134 \times (6 \text{ m}^2) \times (149 \text{ W/m}^2) = \mathbf{638 \text{ W}} \\ \dot{Q}_{\text{solar gain, 15:00}} &= 0.7134 \times (6 \text{ m}^2) \times (114 \text{ W/m}^2) = \mathbf{488 \text{ W}}\end{aligned}$$

South wall:

$$\begin{aligned}\dot{Q}_{\text{solar gain, 9:00}} &= 0.7134 \times (8 \text{ m}^2) \times (190 \text{ W/m}^2) = \mathbf{1084 \text{ W}} \\ \dot{Q}_{\text{solar gain, 12:00}} &= 0.7134 \times (8 \text{ m}^2) \times (395 \text{ W/m}^2) = \mathbf{2254 \text{ W}} \\ \dot{Q}_{\text{solar gain, 15:00}} &= 0.7134 \times (8 \text{ m}^2) \times (190 \text{ W/m}^2) = \mathbf{1084 \text{ W}}\end{aligned}$$

West wall:

$$\begin{aligned}\dot{Q}_{\text{solar gain, 9:00}} &= 0.7134 \times (6 \text{ m}^2) \times (114 \text{ W/m}^2) = \mathbf{488 \text{ W}} \\ \dot{Q}_{\text{solar gain, 12:00}} &= 0.7134 \times (6 \text{ m}^2) \times (149 \text{ W/m}^2) = \mathbf{638 \text{ W}} \\ \dot{Q}_{\text{solar gain, 15:00}} &= 0.7134 \times (6 \text{ m}^2) \times (701 \text{ W/m}^2) = \mathbf{3001 \text{ W}}\end{aligned}$$

Similarly, the solar heat gain of the house through all of the windows in January is determined to be

January:

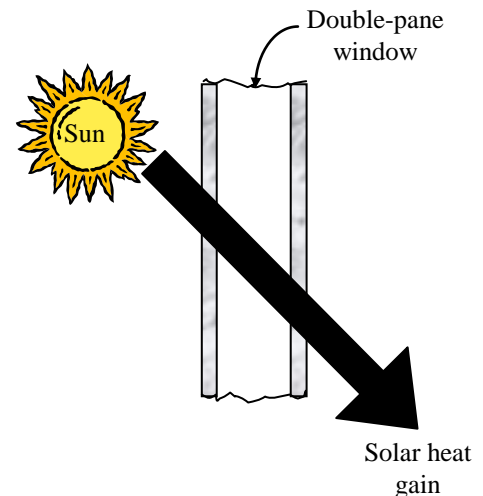

$$\dot{Q}_{\text{solar gain, North}} = 0.7134 \times (4 \text{ m}^2) \times (446 \text{ Wh/m}^2 \cdot \text{day}) = 1273 \text{ Wh/day}$$

$$\dot{Q}_{\text{solar gain, East}} = 0.7134 \times (6 \text{ m}^2) \times (1863 \text{ Wh/m}^2 \cdot \text{day}) = 7974 \text{ Wh/day}$$

$$\dot{Q}_{\text{solar gain, South}} = 0.7134 \times (8 \text{ m}^2) \times (5897 \text{ Wh/m}^2 \cdot \text{day}) = 33,655 \text{ Wh/day}$$

$$\dot{Q}_{\text{solar gain, West}} = 0.7134 \times (6 \text{ m}^2) \times (1863 \text{ Wh/m}^2 \cdot \text{day}) = 7974 \text{ Wh/day}$$

Therefore, for an average day in January,

$$\dot{Q}_{\text{solar gain per day}} = 1273 + 7974 + 33,655 + 7974 = 58,876 \text{ Wh/day} \cong \mathbf{58.9 \text{ kWh/day}}$$

18-46 A house located at 40° N latitude has gray-tinted double pane windows. The total solar heat gain of the house at 9:00, 12:00, and 15:00 solar time in July and the total amount of solar heat gain per day for an average day in January are to be determined.

Assumptions The calculations are performed for an average day in a given month.

Properties The shading coefficient of a gray-tinted double pane window with 6-mm thick glasses is $SC = 0.58$ (Table 18-6). The incident radiation at different windows at different times are given as (Table 18-3)

Month	Time	Solar radiation incident on the surface, W/m ²			
		North	East	South	West
July	9:00	117	701	190	114
July	12:00	138	149	395	149
July	15:00	117	114	190	701
January	Daily total	446	1863	5897	1863

Analysis The solar heat gain coefficient (SHGC) of the windows is determined from Eq.11-57 to be

$$SHGC = 0.87 \times SC = 0.87 \times 0.58 = 0.5046$$

The rate of solar heat gain is determined from

$$\dot{Q}_{\text{solar gain}} = SHGC \times A_{\text{glazing}} \times \dot{q}_{\text{solar, incident}} = 0.5046 \times A_{\text{glazing}} \times \dot{q}_{\text{solar, incident}}$$

Then the rates of heat gain at the 4 walls at 3 different times in July become

North wall:

$$\dot{Q}_{\text{solar gain, 9:00}} = 0.5046 \times (4 \text{ m}^2) \times (117 \text{ W/m}^2) = \mathbf{236 \text{ W}}$$

$$\dot{Q}_{\text{solar gain, 12:00}} = 0.5046 \times (4 \text{ m}^2) \times (138 \text{ W/m}^2) = \mathbf{279 \text{ W}}$$

$$\dot{Q}_{\text{solar gain, 15:00}} = 0.5046 \times (4 \text{ m}^2) \times (117 \text{ W/m}^2) = \mathbf{236 \text{ W}}$$

East wall:

$$\dot{Q}_{\text{solar gain, 9:00}} = 0.5046 \times (6 \text{ m}^2) \times (701 \text{ W/m}^2) = \mathbf{2122 \text{ W}}$$

$$\dot{Q}_{\text{solar gain, 12:00}} = 0.5046 \times (6 \text{ m}^2) \times (149 \text{ W/m}^2) = \mathbf{451 \text{ W}}$$

$$\dot{Q}_{\text{solar gain, 15:00}} = 0.5046 \times (6 \text{ m}^2) \times (114 \text{ W/m}^2) = \mathbf{345 \text{ W}}$$

South wall:

$$\dot{Q}_{\text{solar gain, 9:00}} = 0.5046 \times (8 \text{ m}^2) \times (190 \text{ W/m}^2) = \mathbf{767 \text{ W}}$$

$$\dot{Q}_{\text{solar gain, 12:00}} = 0.5046 \times (8 \text{ m}^2) \times (395 \text{ W/m}^2) = \mathbf{1595 \text{ W}}$$

$$\dot{Q}_{\text{solar gain, 15:00}} = 0.5046 \times (8 \text{ m}^2) \times (190 \text{ W/m}^2) = \mathbf{767 \text{ W}}$$

West wall:

$$\dot{Q}_{\text{solar gain, 9:00}} = 0.5046 \times (6 \text{ m}^2) \times (114 \text{ W/m}^2) = \mathbf{345 \text{ W}}$$

$$\dot{Q}_{\text{solar gain, 12:00}} = 0.5046 \times (6 \text{ m}^2) \times (149 \text{ W/m}^2) = \mathbf{451 \text{ W}}$$

$$\dot{Q}_{\text{solar gain, 15:00}} = 0.5046 \times (6 \text{ m}^2) \times (701 \text{ W/m}^2) = \mathbf{2122 \text{ W}}$$

Similarly, the solar heat gain of the house through all of the windows in January is determined to be

January:

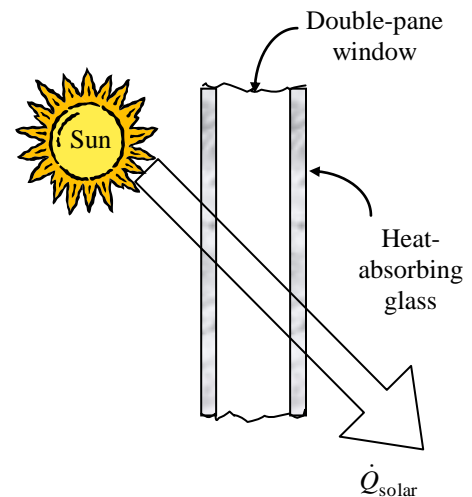

$$\dot{Q}_{\text{solar gain, North}} = 0.5046 \times (4 \text{ m}^2) \times (446 \text{ Wh/m}^2 \cdot \text{day}) = 900 \text{ Wh/day}$$

$$\dot{Q}_{\text{solar gain, East}} = 0.5046 \times (6 \text{ m}^2) \times (1863 \text{ Wh/m}^2 \cdot \text{day}) = 5640 \text{ Wh/day}$$

$$\dot{Q}_{\text{solar gain, South}} = 0.5046 \times (8 \text{ m}^2) \times (5897 \text{ Wh/m}^2 \cdot \text{day}) = 23,805 \text{ Wh/day}$$

$$\dot{Q}_{\text{solar gain, West}} = 0.5046 \times (6 \text{ m}^2) \times (1863 \text{ Wh/m}^2 \cdot \text{day}) = 5640 \text{ Wh/day}$$

Therefore, for an average day in January,

$$\dot{Q}_{\text{solar gain per day}} = 900 + 5640 + 23,805 + 5640 = 35,985 \text{ Wh/day} = \mathbf{35.895 \text{ kWh/day}}$$

18-47 A building at 40° N latitude has double pane heat absorbing type windows that are equipped with light colored venetian blinds. The total solar heat gains of the building through the south windows at solar noon in April for the cases of with and without the blinds are to be determined.

Assumptions The calculations are performed for an “average” day in April, and may vary from location to location.

Properties The shading coefficient of a double pane heat absorbing type windows is $SC = 0.58$ (Table 18-6). It is given to be $SC = 0.30$ in the case of blinds. The solar radiation incident at a South-facing surface at 12:00 noon in April is 559 W/m^2 (Table 18-3).

Analysis The solar heat gain coefficient (SHGC) of the windows without the blinds is determined from

$$SHGC = 0.87 \times SC = 0.87 \times 0.58 = 0.5046$$

Then the rate of solar heat gain through the window becomes

$$\begin{aligned} \dot{Q}_{\text{solar gain, no blinds}} &= SHGC \times A_{\text{glazing}} \times \dot{q}_{\text{solar, incident}} \\ &= 0.5046(76 \text{ m}^2)(559 \text{ W/m}^2) \\ &= \mathbf{21,440 \text{ W}} \end{aligned}$$

In the case of windows equipped with venetian blinds, the SHGC and the rate of solar heat gain become

$$SHGC = 0.87 \times SC = 0.87 \times 0.30 = 0.261$$

Then the rate of solar heat gain through the window becomes

$$\begin{aligned} \dot{Q}_{\text{solar gain, no blinds}} &= SHGC \times A_{\text{glazing}} \times \dot{q}_{\text{solar, incident}} \\ &= 0.261(76 \text{ m}^2)(559 \text{ W/m}^2) \\ &= \mathbf{11,090 \text{ W}} \end{aligned}$$

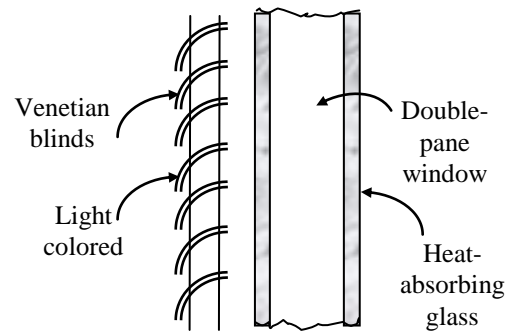

Discussion Note that light colored venetian blinds significantly reduce the solar heat, and thus air-conditioning load in summers.

18-48 A house has double door type windows that are double pane with 6.4 mm of air space and aluminum frames and spacers. It is to be determined if the house is losing more or less heat than it is gaining from the sun through an east window in a typical day in January.

Assumptions 1 The calculations are performed for an “average” day in January. **2** Solar data at 40° latitude can also be used for a location at 39° latitude.

Properties The shading coefficient of a double pane window with 3-mm thick clear glass is $SC = 0.88$ (Table 18-6). The overall heat transfer coefficient for double door type windows that are double pane with 6.4 mm of air space and aluminum frames and spacers is $4.55 \text{ W/m}^2 \cdot ^\circ\text{C}$. The total solar radiation incident at an East-facing surface in January during a typical day is 1863 Wh/m^2 (Table 18-3).

Analysis The solar heat gain coefficient (SHGC) of the windows is determined from

$$SHGC = 0.87 \times SC = 0.87 \times 0.88 = 0.7656$$

Then the solar heat gain through the window per unit area becomes

$$\begin{aligned} Q_{\text{solar gain}} &= SHGC \times A_{\text{glazing}} \times q_{\text{solar, daily total}} \\ &= 0.7656(1 \text{ m}^2)(1863 \text{ Wh/m}^2) \\ &= \mathbf{1426 \text{ Wh} = 1.426 \text{ kWh}} \end{aligned}$$

The heat loss through a unit area of the window during a 24-h period is

$$\begin{aligned} Q_{\text{loss, window}} &= \dot{Q}_{\text{loss, window}} \Delta t = U_{\text{window}} A_{\text{window}} (T_i - T_{0, \text{ave}})(1 \text{ day}) \\ &= (4.55 \text{ W/m}^2 \cdot ^\circ\text{C})(1 \text{ m}^2)(22 - 10)^\circ\text{C}(24 \text{ h}) \\ &= \mathbf{1310 \text{ Wh} = 1.31 \text{ kWh}} \end{aligned}$$

Therefore, the house is losing **less** heat than it is gaining through the East windows during a typical day in January.

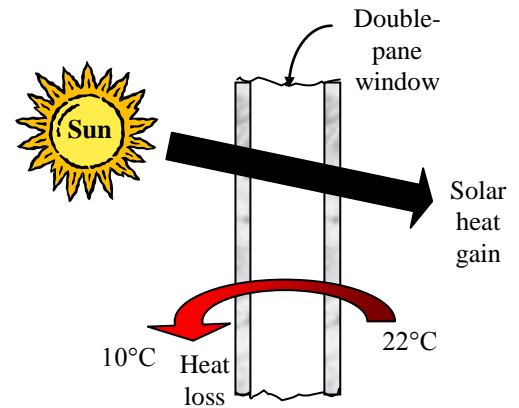

18-49 A house has double door type windows that are double pane with 6.4 mm of air space and aluminum frames and spacers. It is to be determined if the house is losing more or less heat than it is gaining from the sun through a South window in a typical day in January.

Assumptions 1 The calculations are performed for an “average” day in January. **2** Solar data at 40° latitude can also be used for a location at 39° latitude.

Properties The shading coefficient of a double pane window with 3-mm thick clear glass is $SC = 0.88$ (Table 18-6). The overall heat transfer coefficient for double door type windows that are double pane with 6.4 mm of air space and aluminum frames and spacers is $4.55 \text{ W/m}^2 \cdot ^\circ\text{C}$. The total solar radiation incident at a South-facing surface in January during a typical day is 5897 Wh/m^2 (Table 18-3).

Analysis The solar heat gain coefficient (SHGC) of the windows is determined from

$$SHGC = 0.87 \times SC = 0.87 \times 0.88 = 0.7656$$

Then the solar heat gain through the window per unit area becomes

$$\begin{aligned} Q_{\text{solar gain}} &= SHGC \times A_{\text{glazing}} \times q_{\text{solar, daily total}} \\ &= 0.7656(1 \text{ m}^2)(5897 \text{ Wh/m}^2) \\ &= \mathbf{4515 \text{ Wh} = 4.515 \text{ kWh}} \end{aligned}$$

The heat loss through a unit area of the window during a 24-h period is

$$\begin{aligned} Q_{\text{loss, window}} &= \dot{Q}_{\text{loss, window}} \Delta t = U_{\text{window}} A_{\text{window}} (T_i - T_{0, \text{ave}})(1 \text{ day}) \\ &= (4.55 \text{ W/m}^2 \cdot ^\circ\text{C})(1 \text{ m}^2)(22 - 10)^\circ\text{C}(24 \text{ h}) \\ &= \mathbf{1310 \text{ Wh} = 1.31 \text{ kWh}} \end{aligned}$$

Therefore, the house is **losing** much less heat than it is gaining through the South windows during a typical day in January.

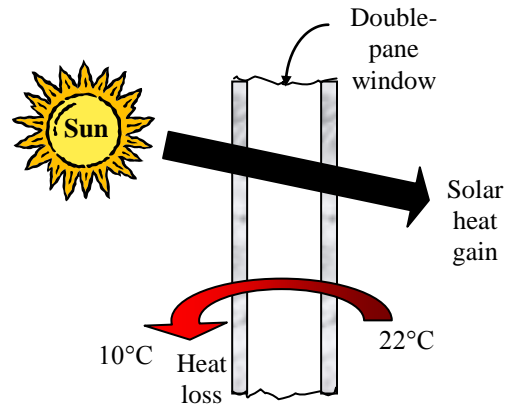

18-50E A house has 1/8-in thick single pane windows with aluminum frames on a West wall. The rate of net heat gain (or loss) through the window at 3 PM during a typical day in January is to be determined.

Assumptions 1 The calculations are performed for an “average” day in January. 2 The frame area relative to glazing area is small so that the glazing area can be taken to be the same as the window area.

Properties The shading coefficient of a 1/8-in thick single pane window is $SC = 1.0$ (Table 18-6). The overall heat transfer coefficient for 1/8-in thick single pane windows with aluminum frames is $6.63 \text{ W/m}^2 \cdot ^\circ\text{C} = 1.17 \text{ Btu/h}\cdot\text{ft}^2 \cdot ^\circ\text{F}$. The total solar radiation incident at a West-facing surface at 3 PM in January during a typical day is $557 \text{ W/m}^2 = 177 \text{ Btu/h}\cdot\text{ft}^2$ (Table 18-3).

Analysis The solar heat gain coefficient (SHGC) of the windows is determined from

$$SHGC = 0.87 \times SC = 0.87 \times 1.0 = 0.87$$

The window area is: $A_{\text{window}} = (9 \text{ ft})(15 \text{ ft}) = 135 \text{ ft}^2$

Then the rate of solar heat gain through the window at 3 PM becomes

$$\begin{aligned} \dot{Q}_{\text{solar gain, 3 PM}} &= SHGC \times A_{\text{glazing}} \times \dot{q}_{\text{solar, 3 PM}} \\ &= 0.87(135 \text{ ft}^2)(177 \text{ Btu/h}\cdot\text{ft}^2) \\ &= 20,789 \text{ Btu/h} \end{aligned}$$

The rate of heat loss through the window at 3 PM is

$$\begin{aligned} \dot{Q}_{\text{loss, window}} &= U_{\text{window}} A_{\text{window}} (T_i - T_o) \\ &= (1.17 \text{ Btu/h}\cdot\text{ft}^2 \cdot ^\circ\text{F})(135 \text{ ft}^2)(78 - 20)^\circ\text{F} \\ &= 9161 \text{ Btu/h} \end{aligned}$$

The house will be gaining heat at 3 PM since the solar heat gain is larger than the heat loss. The rate of net heat gain through the window is

$$\dot{Q}_{\text{net}} = \dot{Q}_{\text{solar gain, 3 PM}} - \dot{Q}_{\text{loss, window}} = 20,789 - 9161 = \mathbf{11,630 \text{ Btu/h}}$$

Discussion The actual heat gain will be less because of the area occupied by the window frame.

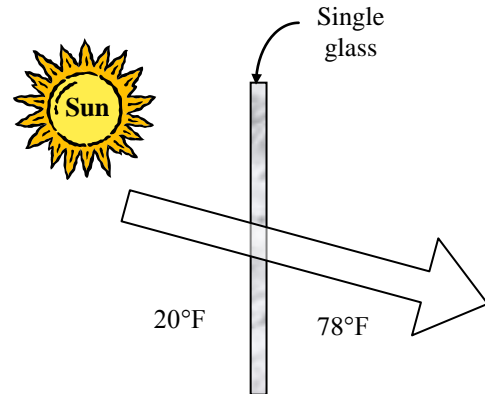

Wind Energy

18-51C *Windmill* is used for *mechanical* power generation (grinding grain, pumping water, etc.) but *wind turbine* is used for electrical power generation, although technically both devices are turbines since they extract energy from the fluid.

18-52C Theoretically, electricity can be generated at all wind speeds but for economical power generation, the minimum wind speed should be about 6 m/s.

18-53C *Cut-in speed* is the minimum wind speed at which useful power can be generated. *Rated speed* is the wind speed that delivers the rated power, usually the maximum power. *Cut-out speed* is the maximum wind speed at which the wind turbine is designed to produce power. At wind speeds greater than the cut-out speed, the turbine blades are stopped by some type of braking mechanism to avoid damage and for safety issues.

18-54C The wind power potential is given by

$$\dot{W}_{\text{available}} = \frac{1}{2} \rho A V^3$$

where ρ is the density of air, A is the blade span area of the wind turbine, and V is the wind velocity. The power potential of a wind turbine is proportional to the density of air, and the density of air is inversely proportional to air temperature through the relation $\rho = \frac{P}{RT}$. Therefore, the location with cooler air has more wind power potential. Note that both locations are at the same pressure since they are at the same altitude.

18-55C The wind power potential is given by

$$\dot{W}_{\text{available}} = \frac{1}{2} \rho A V^3$$

where ρ is the density of air, A is the blade span area of the wind turbine, and V is the wind velocity. The power potential of a wind turbine is proportional to the density of air and the density of air is proportional to atmospheric pressure through the relation $\rho = \frac{P}{RT}$. Since atmospheric pressure is higher at a lower altitude, the location at higher altitude has more wind power potential.

18-56C As a general rule of thumb, a location is considered poor for construction of wind turbines if the average wind power density is less than about 100 W/m², good if it is around 400 W/m², and great if it is greater than about 700 W/m². Therefore, we recommend wind turbine installation in site B and site C only.

18-57C The overall wind turbine efficiency is defined as

$$\eta_{\text{wt,overall}} = \frac{\dot{W}_{\text{electric}}}{\dot{W}_{\text{available}}} = \frac{\dot{W}_{\text{electric}}}{\frac{1}{2} \rho A V^3}$$

where $\dot{W}_{\text{electric}}$ is electric power output, ρ is density of air, A is blade span area, and V is wind velocity. The overall wind turbine efficiency is related to wind turbine efficiency as

$$\eta_{\text{wt,overall}} = \eta_{\text{wt}} \eta_{\text{gearbox/generator}} = \frac{\dot{W}_{\text{shaft}}}{\dot{W}_{\text{available}}} \frac{\dot{W}_{\text{electric}}}{\dot{W}_{\text{shaft}}} = \frac{\dot{W}_{\text{electric}}}{\dot{W}_{\text{available}}}$$

where $\eta_{\text{gearbox/generator}}$ is the gearbox/generator efficiency.

18-58C The theoretical limit for wind turbine efficiency based on the second law of thermodynamics is 100 percent. This represents the conversion of entire kinetic energy of wind into work. This would be the case only when the velocity of air at the turbine exit is zero. This is not possible for practical reasons because air must be taken away at the turbine exit to maintain the mass flow through the turbine. Therefore, there is a limit for wind turbine efficiency which is less than 100 percent, and this is called the Betz limit. The Betz limit is calculated to be 0.5926.

18-59C Turbine A: The given efficiency (41 percent) is *possible* and *realistic*. Turbine B: The given efficiency (59 percent) is *possible* because it is less than Betz limit but is *not probable*. Turbine C: The given efficiency (67 percent) is *not possible* because it is greater than the Betz limit.

18-60 The wind power potential of a wind turbine at a specified wind speed is to be determined.

Assumptions Wind flows steadily at the specified speed.

Properties The gas constant of air is $R = 0.287 \text{ kJ/kg}\cdot\text{K}$.

Analysis The density of air is determined from the ideal gas relation to be

$$\rho = \frac{P}{RT} = \frac{(96 \text{ kPa})}{(0.287 \text{ kPa}\cdot\text{m}^3/\text{kg}\cdot\text{K})(296 \text{ K})} = 1.130 \text{ kg/m}^3$$

The blade span area is

$$A = \pi D^2 / 4 = \pi (50 \text{ m})^2 / 4 = 1963 \text{ m}^2$$

Then the wind power potential is

$$\dot{W}_{\text{available}} = \frac{1}{2} \rho A V_1^3 = \frac{1}{2} (1.130 \text{ kg/m}^3)(1963 \text{ m}^2)(7.5 \text{ m/s})^3 \left(\frac{1 \text{ kJ/kg}}{1000 \text{ m}^2/\text{s}^2} \right) = \mathbf{468 \text{ kW}}$$

18-61 Average wind power density values are given for two locations. The average wind speed in these locations are to be determined.

Properties The density of air is given to be $\rho = 1.18 \text{ kg/m}^3$.

Analysis The relation for wind power density is

$$\text{WPD} = \frac{1}{2} \rho V^3$$

Solving for wind velocity at the two locations, we obtain

$$\text{WPD}_1 = \frac{1}{2} \rho V_1^3 \longrightarrow 200 \text{ W/m}^2 = \frac{1}{2} (1.18 \text{ kg/m}^3) V_1^3 \longrightarrow V_1 = \mathbf{6.97 \text{ m/s}}$$

$$\text{WPD}_2 = \frac{1}{2} \rho V_2^3 \longrightarrow 400 \text{ W/m}^2 = \frac{1}{2} (1.18 \text{ kg/m}^3) V_2^3 \longrightarrow V_2 = \mathbf{8.79 \text{ m/s}}$$

18-62 A wind turbine is to generate power with a specified wind speed. The average electric power output, the amount of electricity produced, and the revenue generated are to be determined.

Assumptions Wind flows steadily at the specified speed.

Properties The density of air is given to be $\rho = 1.3 \text{ kg/m}^3$.

Analysis (a) The blade span area is

$$A = \pi D^2 / 4 = \pi (25 \text{ m})^2 / 4 = 490.9 \text{ m}^2$$

The wind power potential is

$$\dot{W}_{\text{available}} = \frac{1}{2} \rho A V_1^3 = \frac{1}{2} (1.3 \text{ kg/m}^3) (490.9 \text{ m}^2) (6 \text{ m/s})^3 \left(\frac{1 \text{ kJ/kg}}{1000 \text{ m}^2/\text{s}^2} \right) = 68.92 \text{ kW}$$

The electric power generated is

$$\dot{W}_{\text{electric}} = \eta_{\text{wt, overall}} \dot{W}_{\text{available}} = (0.34)(68.92 \text{ kW}) = \mathbf{23.43 \text{ kW}}$$

(b) The amount of electricity produced is determined from

$$W_{\text{electric}} = \dot{W}_{\text{electric}} \times \text{Operating hours} = (23.43 \text{ kW})(8000 \text{ h}) = \mathbf{187,500 \text{ kWh}}$$

(c) The revenue generated is

$$\text{Revenue} = W_{\text{electric}} \times \text{Unit price of electricity} = (187,500 \text{ kWh})(\$0.09/\text{kWh}) = \mathbf{\$16,900}$$

18-63 A wind turbine generates a certain amount of electricity during a week period. The average wind speed during this period is to be determined.

Properties The density of air is given to be $\rho = 1.16 \text{ kg/m}^3$.

Analysis The total operating hours during a week period is

$$\text{Operating hours} = 7 \times 24 \text{ h} = 168 \text{ h}$$

The average rate of electricity production is

$$\dot{W}_{\text{electric}} = \frac{W_{\text{electric}}}{\text{Operating hours}} = \frac{11,000 \text{ kWh}}{168 \text{ h}} = 65.48 \text{ kW}$$

The available wind power is

$$\dot{W}_{\text{available}} = \frac{\dot{W}_{\text{electric}}}{\eta_{\text{wt, overall}}} = \frac{65.48 \text{ kW}}{0.28} = 233.8 \text{ kW}$$

The blade span area is

$$A = \pi D^2 / 4 = \pi (40 \text{ m})^2 / 4 = 1257 \text{ m}^2$$

Finally, the average wind speed is determined from the definition of available wind power to be

$$\begin{aligned} \dot{W}_{\text{available}} &= \frac{1}{2} \rho A V^3 \\ 233.8 \text{ kW} &= \frac{1}{2} (1.16 \text{ kg/m}^3) (1257 \text{ m}^2) V^3 \left(\frac{1 \text{ kJ/kg}}{1000 \text{ m}^2/\text{s}^2} \right) \\ V &= \mathbf{6.85 \text{ m/s}} \end{aligned}$$

18-64E A wind turbine is to generate power with two specified wind speeds. The amount of electricity that can be produced by the turbine and the blade tip speed are to be determined.

Assumptions Wind flows steadily at the specified speeds.

Properties The density of air is given to be $\rho = 0.075 \text{ lbm/ft}^3$.

Analysis The blade span area is

$$A = \pi D^2 / 4 = \pi (185 \text{ ft})^2 / 4 = 26,880 \text{ ft}^2$$

The wind power potential at the wind speed of 16 ft/s is

$$\dot{W}_{\text{available},1} = \frac{1}{2} \rho A V_1^3 = \frac{1}{2} (0.075 \text{ lbm/ft}^3)(26,880 \text{ ft}^2)(16 \text{ ft/s})^3 \left(\frac{1 \text{ kW}}{23,730 \text{ lbm} \cdot \text{ft}^2/\text{s}^3} \right) = 174.0 \text{ kW}$$

The wind power potential at the wind speed of 24 ft/s is

$$\dot{W}_{\text{available},2} = \frac{1}{2} \rho A V_2^3 = \frac{1}{2} (0.075 \text{ lbm/ft}^3)(26,880 \text{ ft}^2)(24 \text{ ft/s})^3 \left(\frac{1 \text{ kW}}{23,730 \text{ lbm} \cdot \text{ft}^2/\text{s}^3} \right) = 587.2 \text{ kW}$$

The overall wind turbine efficiency at a wind speed of 16 ft/s is

$$\eta_{\text{wt,overall},1} = \eta_{\text{wt},1} \eta_{\text{gen}} = (0.30)(0.93) = 0.2790$$

The overall wind turbine efficiency at a wind speed of 24 ft/s is

$$\eta_{\text{wt,overall},2} = \eta_{\text{wt},2} \eta_{\text{gen}} = (0.35)(0.93) = 0.3255$$

The electric power generated at a wind speed of 16 ft/s is

$$\dot{W}_{\text{electric},1} = \eta_{\text{wt,overall},1} \dot{W}_{\text{available},1} = (0.2790)(174.0 \text{ kW}) = 48.54 \text{ kW}$$

The electric power generated at a wind speed of 24 ft/s is

$$\dot{W}_{\text{electric},2} = \eta_{\text{wt,overall},2} \dot{W}_{\text{available},2} = (0.3255)(587.2 \text{ kW}) = 191.1 \text{ kW}$$

The amount of electricity produced at a wind speed of 16 ft/s is

$$W_{\text{electric},1} = \dot{W}_{\text{electric},1} \times \text{Operating hours}_1 = (48.54 \text{ kW})(3000 \text{ h}) = 145,630 \text{ kWh}$$

The amount of electricity produced at a wind speed of 24 ft/s is

$$W_{\text{electric},2} = \dot{W}_{\text{electric},2} \times \text{Operating hours}_2 = (191.1 \text{ kW})(4000 \text{ h}) = 764,560 \text{ kWh}$$

The total amount of electricity produced is

$$W_{\text{electric,total}} = W_{\text{electric},1} + W_{\text{electric},2} = 145,630 + 764,560 = \mathbf{910,000 \text{ kWh}}$$

Noting that the tip of blade travels a distance of πD per revolution, the tip velocity of the turbine blade for a rotational speed of n becomes

$$V_{\text{tip}} = \pi D n = \pi (185 \text{ ft}) (15 / \text{min}) \left(\frac{1 \text{ min}}{60 \text{ s}} \right) \left(\frac{1 \text{ mi/h}}{1.46667 \text{ ft/s}} \right) = \mathbf{99.1 \text{ mph}}$$

18-65E Air velocities at the inlet and exit of a turbine are given. The wind turbine efficiency is to be determined when the frictional effects are neglected.

Assumptions Wind flows steadily at the specified speeds.

Analysis The wind turbine efficiency can be determined from Eq. 18-44 to be

$$V_2 = V_1 \sqrt{1 - \eta_{wt}}$$
$$19.5 \text{ ft/s} = (25 \text{ ft/s}) \sqrt{1 - \eta_{wt}}$$
$$\eta_{wt} = 0.3916 = \mathbf{39.2\text{percent}}$$

Hydropower

18-66C A water pump increases the pressure of water by supplying mechanical energy. A hydroturbine converts potential energy of water into mechanical shaft work and the pressure of water decreases across the turbine.

18-67C The maximum work that can be produced by this turbine is determined from

$$w_{\max} = (P_1 - P_2)/\rho$$

where ρ is the density of water.

18-68C We are usually more interested in the overall efficiency of turbine-generator combination rather than the turbine efficiency because a turbine is usually packaged together with its generator and it is much easier to measure the electric power output from the generator compared to shaft power output from the turbine.

18-69C No, we do not agree. The limitation that a machine cannot have an efficiency of 100 percent even in the absence of irreversibilities holds for heat engines which convert heat to work. A hydraulic turbine is not a heat engine as it converts mechanical energy into work and the upper limit for its efficiency is 100 percent.

18-70C No, we do not agree. A wind turbine converts kinetic energy of air into work and the Betz limit is due to the fact that the velocity of air at the wind turbine exit cannot be zero to maintain the flow. A hydraulic turbine, on the other hand, converts potential energy of water into work and the water velocities just upstream and downstream of the turbine are essentially equal to each other. Therefore, the upper limit for the efficiency of a hydraulic turbine is 100 percent.

18-71C The overall efficiency of a hydroelectric power plant can be expressed as

$$\eta_{\text{plant}} = \eta_{\text{generator}} \times \eta_{\text{turbine}} \times \eta_{\text{piping}}$$

Substituting the definition of each efficiency, we obtain

$$\begin{aligned} \eta_{\text{plant}} &= \eta_{\text{generator}} \eta_{\text{turbine}} \eta_{\text{piping}} \\ &= \left(\frac{\dot{W}_{\text{electric}}}{\dot{W}_{\text{shaft}}} \right) \left(\frac{\dot{W}_{\text{shaft}}}{\dot{W}_{\text{max}} - \dot{E}_{\text{mech, loss, piping}}} \right) \left(1 - \frac{\dot{E}_{\text{mech, loss, piping}}}{\dot{W}_{\text{max}}} \right) \\ &= \left(\frac{\dot{W}_{\text{electric}}}{\dot{W}_{\text{shaft}}} \right) \left[\frac{\dot{W}_{\text{shaft}}}{\dot{W}_{\text{max}} (1 - \dot{E}_{\text{mech, loss, piping}}/\dot{W}_{\text{max}})} \right] \left(1 - \frac{\dot{E}_{\text{mech, loss, piping}}}{\dot{W}_{\text{max}}} \right) \\ &= \frac{\dot{W}_{\text{electric}}}{\dot{W}_{\text{max}}} \end{aligned}$$

Therefore, the overall efficiency of a hydroelectric power plant is defined as the electrical power output divided by the maximum power potential.

18-72C There are two basic types of dynamic turbine—*impulse* and *reaction*. Comparing the two power-producing dynamic turbines, impulse turbines require a *higher head*, but can operate with a *smaller volume flow rate*. Reaction turbines can operate with much *less head*, but require a *higher volume flow rate*.

18-73 The power that can be produced by an ideal turbine from a large dam is to be determined.

Assumptions 1 The flow is steady. 2 Water levels at the reservoir and the discharge site remain constant.

Properties The density of water is taken to be $\rho = 1000 \text{ kg/m}^3 = 1 \text{ kg/L}$.

Analysis The total mechanical energy the water in a dam possesses is equivalent to the potential energy of water at the free surface of the dam (relative to free surface of discharge water), and it can be converted to work entirely for an ideal operation. Therefore, the maximum power that can be generated is equal to potential energy of the water. Noting that the mass flow rate is $\dot{m} = \rho\dot{V}$, the maximum power is determined from

$$\begin{aligned}\dot{W}_{\max} &= \dot{m}gH_{\text{gross}} = \rho\dot{V}gH_{\text{gross}} \\ &= (1 \text{ kg/L})(1500 \text{ L/s})(9.81 \text{ m/s}^2)(65 \text{ m}) \left(\frac{1 \text{ kJ/kg}}{1000 \text{ m}^2/\text{s}^2} \right) \\ &= \mathbf{15.94 \text{ kW}}\end{aligned}$$

18-74 The pressures just upstream and downstream of a hydraulic turbine are given. The maximum work and the flow rate of water for a given power are to be determined.

Assumptions 1 The flow is steady. 2 Water levels at the reservoir and the discharge site remain constant.

Properties The density of water is taken to be $\rho = 1000 \text{ kg/m}^3 = 1 \text{ kg/L}$.

Analysis The maximum work per unit mass of water flow is determined from

$$w_{\max} = \frac{P_1 - P_2}{\rho} = \frac{(1025 - 100) \text{ kPa}}{1000 \text{ kg/m}^3} \left(\frac{1 \text{ kJ}}{1 \text{ kPa} \cdot \text{m}^3} \right) = \mathbf{1.225 \text{ kJ/kg}}$$

The flow rate of water is

$$\begin{aligned}\dot{W}_{\max} &= \dot{m}w_{\max} = \rho\dot{V}w_{\max} \\ \dot{V} &= \frac{\dot{W}_{\max}}{\rho w_{\max}} = \frac{100 \text{ kJ/s}}{(1 \text{ kg/L})(1.225 \text{ kJ/kg})} \left(\frac{60 \text{ s}}{1 \text{ min}} \right) \\ &= \mathbf{4898 \text{ L/min}}\end{aligned}$$

18-75 The efficiency of a hydraulic turbine is to be determined.

Assumptions **1** The flow is steady. **2** Water levels at the reservoir and the discharge site remain constant.

Properties The density of water is taken to be $\rho = 1000 \text{ kg/m}^3 = 1 \text{ kg/L}$.

Analysis The total mechanical energy the water in a dam possesses is equivalent to the potential energy of water at the free surface of the dam (relative to free surface of discharge water), and it can be converted to work entirely for an ideal operation. Therefore, the maximum power that can be generated is equal to potential energy of the water. Noting that the mass flow rate is $\dot{m} = \rho\dot{V}$, the maximum power is determined from

$$\begin{aligned}\dot{W}_{\max} &= \dot{m}gH_{\text{gross}} = \rho\dot{V}gH_{\text{gross}} \\ &= (1 \text{ kg/L})(11,500 \text{ L/min})\left(\frac{1 \text{ min}}{60 \text{ s}}\right)(9.81 \text{ m/s}^2)(160 \text{ m})\left(\frac{1 \text{ kJ/kg}}{1000 \text{ m}^2/\text{s}^2}\right) \\ &= 300.8 \text{ kW}\end{aligned}$$

The turbine efficiency is determined from its definition to be

$$\eta_{\text{turbine}} = \frac{\dot{W}_{\text{shaft}}}{\dot{W}_{\max}} = \frac{250 \text{ kW}}{300.8 \text{ kW}} = 0.831 = \mathbf{83.1\text{percent}}$$

18-76 A hydraulic turbine-generator unit produces power from a dam. The overall efficiency of the turbine-generator unit, the turbine efficiency, and the power losses due to inefficiencies in the turbine and the generator are to be determined.

Assumptions 1 The flow is steady. 2 Water levels at the reservoir and the discharge site remain constant.

Properties The density of water is taken to be $\rho = 1000 \text{ kg/m}^3 = 1 \text{ kg/L}$.

Analysis (a) The total mechanical energy the water in a dam possesses is equivalent to the potential energy of water at the free surface of the dam (relative to free surface of discharge water), and it can be converted to work entirely for an ideal operation. Therefore, the maximum power that can be generated is equal to potential energy of the water. Noting that the mass flow rate is $\dot{m} = \rho \dot{V}$, the maximum power is determined from

$$\begin{aligned}\dot{W}_{\max} &= \dot{m}gH_{\text{gross}} = \rho \dot{V}gH_{\text{gross}} \\ &= (1 \text{ kg/L})(1020 \text{ L/s})(9.81 \text{ m/s}^2)(75 \text{ m}) \left(\frac{1 \text{ kJ/kg}}{1000 \text{ m}^2/\text{s}^2} \right) \\ &= 750.5 \text{ kW}\end{aligned}$$

The overall efficiency of turbine-generator unit is determined from its definition to be

$$\eta_{\text{turbine-generator}} = \frac{\dot{W}_{\text{electric}}}{\dot{W}_{\max}} = \frac{630 \text{ kW}}{750.5 \text{ kW}} = 0.8395 = \mathbf{84.0\text{percent}}$$

(b) The turbine efficiency is determine from

$$\eta_{\text{turbine}} = \frac{\eta_{\text{turbine-generator}}}{\eta_{\text{generator}}} = \frac{0.8395}{0.96} = 0.8745 = \mathbf{87.5\text{percent}}$$

(c) The shaft power output from the turbine is

$$\dot{W}_{\text{shaft}} = \frac{\dot{W}_{\text{electric}}}{\eta_{\text{generator}}} = \frac{630 \text{ kW}}{0.96} = 656.3 \text{ kW}$$

Finally, the power losses due to inefficiencies in the turbine and generator are

$$\dot{W}_{\text{loss,turbine}} = \dot{W}_{\max} - \dot{W}_{\text{shaft}} = 750.5 - 656.3 = \mathbf{94.2\text{kW}}$$

$$\dot{W}_{\text{loss,generator}} = \dot{W}_{\text{shaft}} - \dot{W}_{\text{electric}} = 656.3 - 630 = \mathbf{26.3\text{kW}}$$

18-77E The pressures just upstream and downstream of a hydraulic turbine are given. The shaft power output from the turbine and the height of the reservoir are to be determined.

Assumptions 1 The flow is steady. 2 Water levels at the reservoir and the discharge site remain constant.

Properties The density of water is taken to be $\rho = 62.4 \text{ lbm/ft}^3$.

Analysis (a) The maximum work per unit mass of water flow is determined from

$$\dot{W}_{\max} = \dot{m} \frac{P_1 - P_2}{\rho} = (280 \text{ lbm/s}) \frac{(95 - 15) \text{ psia}}{62.4 \text{ lbm/ft}^3} \left(\frac{1 \text{ Btu}}{5.40395 \text{ psia} \cdot \text{ft}^3} \right) \left(\frac{1 \text{ kJ}}{0.94782 \text{ Btu}} \right) = 70.09 \text{ kW}$$

The shaft power is

$$\dot{W}_{\text{shaft}} = \eta_{\text{turbine}} \dot{W}_{\max} = (0.86)(70.09 \text{ kW}) = \mathbf{60.3 \text{ kW}}$$

(b) The height of the reservoir is determined from

$$\begin{aligned} \dot{W}_{\max} &= \dot{m}gh \\ h &= \frac{\dot{W}_{\max}}{\dot{m}g} = \frac{70.09 \text{ kW}}{(280 \text{ lbm/s})(32.2 \text{ ft/s}^2)} \left(\frac{1 \text{ kW}}{23,730 \text{ lbm} \cdot \text{ft}^2/\text{s}^3} \right) = \mathbf{185 \text{ ft}} \end{aligned}$$

18-78 The irreversible head losses in the penstock and its inlet and those after the exit of the draft tube are given. The power loss due to irreversible head loss, the efficiency of the piping, and the electric power output are to be determined.

Assumptions 1 The flow is steady. 2 Water levels at the reservoir and the discharge site remain constant.

Properties The density of water is taken to be $\rho = 1000 \text{ kg/m}^3 = 1 \text{ kg/L}$.

Analysis (a) The power loss due to irreversible head loss is determined from

$$\begin{aligned}\dot{E}_{\text{loss,piping}} &= \rho \dot{V} g h_L \\ &= (1 \text{ kg/L})(4000/60 \text{ L/s})(9.81 \text{ m/s}^2)(7 \text{ m}) \left(\frac{1 \text{ kJ/kg}}{1000 \text{ m}^2/\text{s}^2} \right) \\ &= \mathbf{4.578 \text{ kW}}\end{aligned}$$

(b) The efficiency of the piping is determined from the head loss and gross head to be

$$\eta_{\text{piping}} = 1 - \frac{h_L}{H_{\text{gross}}} = 1 - \frac{7 \text{ m}}{140 \text{ m}} = 0.950 = \mathbf{95.0 \text{ percent}}$$

(c) The maximum power is determined from

$$\begin{aligned}\dot{W}_{\text{max}} &= \dot{m} g H_{\text{gross}} = \rho \dot{V} g H_{\text{gross}} \\ &= (1 \text{ kg/L})(4000/60 \text{ L/s})(9.81 \text{ m/s}^2)(140 \text{ m}) \left(\frac{1 \text{ kJ/kg}}{1000 \text{ m}^2/\text{s}^2} \right) \\ &= \mathbf{91.56 \text{ kW}}\end{aligned}$$

The overall efficiency of the hydroelectric plant is

$$\eta_{\text{plant}} = \eta_{\text{turbine-generator}} \eta_{\text{piping}} = (0.84)(0.950) = 0.798$$

The electric power output is

$$\dot{W}_{\text{electric}} = \eta_{\text{plant}} \dot{W}_{\text{max}} = (0.798)(91.56 \text{ kW}) = \mathbf{73.1 \text{ kW}}$$

18-79 Various efficiencies of a hydroelectric power plant are given. The overall efficiency of the plant and the electric power output are to be determined.

Assumptions 1 The flow is steady. 2 Water levels at the reservoir and the discharge site remain constant.

Properties The density of water is taken to be $\rho = 1000 \text{ kg/m}^3 = 1 \text{ kg/L}$.

Analysis The overall efficiency of the hydroelectric plant is determined from

$$\eta_{\text{plant}} = \eta_{\text{turbine}}\eta_{\text{generator}}\eta_{\text{piping}} = (0.87)(0.97)(0.98) = 0.827 = \mathbf{82.7\text{percent}}$$

The maximum power is determined from

$$\begin{aligned}\dot{W}_{\text{max}} &= \dot{m}gH_{\text{gross}} = \rho\dot{V}gH_{\text{gross}} \\ &= (1 \text{ kg/L})(600 \text{ L/s})(9.81 \text{ m/s}^2)(220 \text{ m})\left(\frac{1 \text{ kJ/kg}}{1000 \text{ m}^2/\text{s}^2}\right) \\ &= 1295 \text{ kW}\end{aligned}$$

The electric power output is

$$\dot{W}_{\text{electric}} = \eta_{\text{plant}}\dot{W}_{\text{max}} = (0.827)(1295 \text{ kW}) = \mathbf{1071 \text{ kW}}$$

18-80 A hydroelectric power plant operating 80 percent of the time is considered. The revenue that can be generated in a year is to be determined.

Assumptions 1 The flow is steady. 2 Water levels at the reservoir and the discharge site remain constant.

Properties The density of water is taken to be $\rho = 1000 \text{ kg/m}^3 = 1 \text{ kg/L}$.

Analysis The maximum power for one turbine is determined from

$$\begin{aligned}\dot{W}_{\text{max}} &= \dot{m}gH_{\text{gross}} = \rho\dot{V}gH_{\text{gross}} \\ &= (1 \text{ kg/L})(3300/60 \text{ L/s})(9.81 \text{ m/s}^2)(150 \text{ m})\left(\frac{1 \text{ kJ/kg}}{1000 \text{ m}^2/\text{s}^2}\right) \\ &= 80.93 \text{ kW}\end{aligned}$$

The electric power output is

$$\dot{W}_{\text{electric}} = \eta_{\text{plant}}\dot{W}_{\text{max}} = (0.90)(80.93 \text{ kW}) = 72.84 \text{ kW}$$

Noting that the plant operates 80 percent of the time, the operating hours in one year is

$$\text{Operating hours} = 0.80 \times 365 \times 24 = 7008 \text{ h}$$

The amount of electricity produced per year by one turbine is

$$W_{\text{electric}} = \dot{W}_{\text{electric}} \times \text{Operating hours} = (72.84 \text{ kW})(7008 \text{ h}) = 510,500 \text{ kWh}$$

Finally, the revenue generated by 18 such turbines is

$$\text{Revenue} = n_{\text{turbine}} \times W_{\text{electric}} \times \text{Unit price of electricity} = (18)(510,500 \text{ kWh})(\$0.095/\text{kWh}) = \mathbf{\$873,000}$$

Geothermal Energy

18-81C One common classification of geothermal resources is based on their temperature.

High temperature resource: $T > 150^{\circ}\text{C}$

Medium temperature resource: $90^{\circ}\text{C} < T < 150^{\circ}\text{C}$

Low temperature resource: $T < 90^{\circ}\text{C}$

18-82C There are several options for utilizing the thermal energy produced from geothermal energy systems: Electricity production, space heating and cooling, cogeneration, and heat pump. The most common use of geothermal energy is electricity production.

18-83C The quality or work potential of geothermal resources is proportional to temperature of the source. The maximum thermal efficiency of a geothermal power plant utilizing a source at 110°C and a sink temperature of 25°C is $\eta_{\text{th,max}} = 1 - (25+273)/(110+273) = 0.222 = 22.2\%$. The actual efficiency of the proposed power plant will be much lower than this value. It is very unlikely that a power plant investment on this site will be feasible. It makes both thermodynamic and economic sense to use this source for heating or cooling applications.

18-84C Approximate temperature requirements for geothermal applications are

Electricity production $\Rightarrow T > 120^{\circ}\text{C}$

Cooling $\Rightarrow T > 95^{\circ}\text{C}$

Heating $\Rightarrow T > 50^{\circ}\text{C}$

18-85C Ground-source heat pumps are also called geothermal heat pumps as they utilize the heat of the earth. These systems use higher ground temperatures in winter for heat absorption (heating mode) and cooler ground temperatures in summer for heat rejection (cooling mode), and this is the reason for higher COPs.

18-86C The purpose of flashing process is to convert saturated or compressed liquid to a liquid-vapor mixture. The resulting mixture is sent to turbine for power production. The flashing process is a constant-enthalpy process. Both pressure and temperature decreases during this process.

18-87C This is a liquid geothermal resource at a relatively low temperature and a binary cycle is best suited for power generation.

18-88E A geothermal site contains saturated mixture of geothermal water at 300°F. The maximum thermal efficiency and the maximum amount of power are to be determined.

Assumptions 1 Steady operating conditions exist. **2** Kinetic and potential energy changes are negligible. **3** Water properties will be used for geothermal fluid.

Analysis The maximum thermal efficiency can be determined from the Carnot efficiency relation using the geothermal source and dead state temperatures:

$$\eta_{\text{th,max}} = 1 - \frac{T_L}{T_H} = 1 - \frac{(80 + 460) \text{ R}}{(300 + 460) \text{ R}} = 0.2895 = \mathbf{29.0\text{percent}}$$

The enthalpy and entropy values of geothermal water at the wellhead state and dead state are obtained from steam tables:

$$\left. \begin{array}{l} T_1 = 300^\circ\text{F} \\ x_1 = 0.35 \end{array} \right\} \begin{array}{l} h_1 = 588.31 \text{ Btu/lbm} \\ s_1 = 0.8566 \text{ Btu/lbm} \cdot \text{R} \end{array} \quad (\text{Table A-4E})$$

$$\left. \begin{array}{l} T_0 = 80^\circ\text{F} \\ x_0 = 0 \end{array} \right\} \begin{array}{l} h_0 = 48.07 \text{ Btu/lbm} \\ s_0 = 0.09328 \text{ Btu/lbm} \cdot \text{R} \end{array} \quad (\text{Table A-4E})$$

The maximum power potential is equal to the exergy of the geothermal water available at the wellhead:

$$\begin{aligned} \dot{W}_{\text{max}} &= \dot{X}_1 = \dot{m}_1 [h_1 - h_0 - T_0 (h_1 - h_0)] \\ &= (100 \text{ lbm/s}) [(588.31 - 48.07) \text{ Btu/lbm} - (0.8566 - 0.09328) \text{ Btu/lbm} \cdot \text{R}] \left(\frac{1 \text{ kW}}{0.94782 \text{ Btu/s}} \right) \\ &= \mathbf{13,500 \text{ kW}} \end{aligned}$$

18-89 A residential district is to be heated by geothermal water in winter. The revenue generated due to selling geothermal heat is to be determined.

Assumptions 1 Steady operating conditions exist. **2** Kinetic and potential energy changes are negligible. **3** Water properties will be used for geothermal fluid.

Properties The specific heat of water at room temperature is $c_p = 4.18 \text{ kJ/kg} \cdot ^\circ\text{C}$.

Analysis The rate of geothermal heat supplied to the district is determined from

$$\dot{Q}_{\text{heat}} = \dot{m} c_p (T_1 - T_2) = (70 \text{ kg/s})(4.18 \text{ kJ/kg} \cdot ^\circ\text{C})(90 - 50)^\circ\text{C} = 11,704 \text{ kW}$$

The amount of heat supplied for a period of 2500 hours is

$$Q_{\text{heat}} = \dot{Q}_{\text{heat}} \times \text{Operating hours} = (11,704 \text{ kJ/s})(2500 \times 3600 \text{ s}) = 1.053 \times 10^{11} \text{ kJ}$$

The revenue generated by selling the geothermal heat is

$$\begin{aligned} \text{Revenue} &= Q_{\text{heat}} \times \text{Unit price of geothermal heat} \\ &= (1.053 \times 10^{11} \text{ kJ})(\$1.2 \times 10^{-5} / \text{kJ}) \\ &= \$1.264 \times 10^6 \\ &= \mathbf{\$1.264 \text{ millions}} \end{aligned}$$

18-90E Geothermal water is to be used for space cooling. The potential revenue that can be generated by this geothermal cooling system is to be determined.

Assumptions 1 Steady operating conditions exist. 2 Kinetic and potential energy changes are negligible. 3 Water properties will be used for geothermal fluid.

Properties The specific heat of water at room temperature is $c_p = 1.0 \text{ Btu/lbm}\cdot^\circ\text{F}$.

Analysis The rate of heat transfer in the generator of the absorption system is

$$\dot{Q}_{\text{gen}} = \dot{m}c_p(T_1 - T_2) = (86,000 \text{ lbm/h})(1.0 \text{ Btu/lbm}\cdot^\circ\text{F})(210 - 180)^\circ\text{F} = 2.580 \times 10^6 \text{ Btu/h}$$

Using the definition of the COP of an absorption cooling system, the rate of cooling is determined to be

$$\text{COP}_{\text{ABS}} = \frac{\dot{Q}_{\text{cool}}}{\dot{Q}_{\text{gen}}} \longrightarrow \dot{Q}_{\text{cool}} = \text{COP} \times \dot{Q}_{\text{gen}} = (0.70)(2.580 \times 10^6 \text{ Btu/h}) \left(\frac{1 \text{ kW}}{3412.14 \text{ Btu/h}} \right) = 529.3 \text{ kW}$$

If a conventional cooling system with a COP of 2.3 is used for this cooling, the power input would be

$$\text{COP} = \frac{\dot{Q}_{\text{cool}}}{\dot{W}_{\text{in}}} \longrightarrow \dot{W}_{\text{in}} = \frac{\dot{Q}_{\text{cool}}}{\text{COP}} = \frac{529.3 \text{ kW}}{2.3} = 230.1 \text{ kW}$$

The electricity consumption for a period of 2000 hours is

$$W_{\text{in}} = \dot{W}_{\text{in}} \times \text{Operating hours} = (230.1 \text{ kW})(2000 \text{ h}) = 460,250 \text{ kWh}$$

At a discount of 20 percent, the revenue generated by selling the geothermal cooling is

$$\begin{aligned} \text{Revenue} &= (1 - f_{\text{discount}}) \times W_{\text{in}} \times \text{Unit price of electricity} \\ &= (1 - 0.2)(460,250 \text{ kWh})(\$0.14/\text{kWh}) \\ &= \mathbf{\$51,550} \end{aligned}$$

18-91 A single-flash geothermal power plant uses hot geothermal water at 230°C as the heat source. The mass flow rate of steam through the turbine, the isentropic efficiency of the turbine, the power output from the turbine, and the thermal efficiency of the plant are to be determined.

Assumptions 1 Steady operating conditions exist. 2 Kinetic and potential energy changes are negligible.

Analysis (a) We use properties of water for geothermal water (Tables A-4 through A-6)

$$\left. \begin{array}{l} T_1 = 230^\circ\text{C} \\ x_1 = 0 \end{array} \right\} h_1 = 990.14 \text{ kJ/kg}$$

$$\left. \begin{array}{l} P_2 = 500 \text{ kPa} \\ h_2 = h_1 = 990.14 \text{ kJ/kg} \end{array} \right\} x_2 = \frac{h_2 - h_f}{h_{fg}} = \frac{990.14 - 640.09}{2108} = 0.1661$$

The mass flow rate of steam through the turbine is

$$\dot{m}_3 = x_2 \dot{m}_1 = (0.1661)(230 \text{ kg/s}) = \mathbf{38.20 \text{ kg/s}}$$

(b) Turbine:

$$\left. \begin{array}{l} P_3 = 500 \text{ kPa} \\ x_3 = 1 \end{array} \right\} \begin{array}{l} h_3 = 2748.1 \text{ kJ/kg} \\ s_3 = 6.8207 \text{ kJ/kg} \cdot \text{K} \end{array}$$

$$\left. \begin{array}{l} P_4 = 10 \text{ kPa} \\ s_4 = s_3 \end{array} \right\} h_{4s} = 2160.3 \text{ kJ/kg}$$

$$\left. \begin{array}{l} P_4 = 10 \text{ kPa} \\ x_4 = 0.90 \end{array} \right\} h_4 = h_f + x_4 h_{fg} = 191.81 + (0.90)(2392.1) = 2344.7 \text{ kJ/kg}$$

$$\eta_T = \frac{h_3 - h_4}{h_3 - h_{4s}} = \frac{2748.1 - 2344.7}{2748.1 - 2160.3} = \mathbf{0.686}$$

(c) The power output from the turbine is

$$\dot{W}_{T,\text{out}} = \dot{m}_3 (h_3 - h_4) = (38.20 \text{ kJ/kg})(2748.1 - 2344.7) \text{ kJ/kg} = \mathbf{15,410 \text{ kW}}$$

(d) We use saturated liquid state at the standard temperature for dead state enthalpy

$$\left. \begin{array}{l} T_0 = 25^\circ\text{C} \\ x_0 = 0 \end{array} \right\} h_0 = 104.83 \text{ kJ/kg}$$

$$\dot{E}_{\text{in}} = \dot{m}_1 (h_1 - h_0) = (230 \text{ kJ/kg})(990.14 - 104.83) \text{ kJ/kg} = 203,622 \text{ kW}$$

$$\eta_{\text{th}} = \frac{\dot{W}_{T,\text{out}}}{\dot{E}_{\text{in}}} = \frac{15,410}{203,622} = 0.0757 = \mathbf{7.6\%}$$

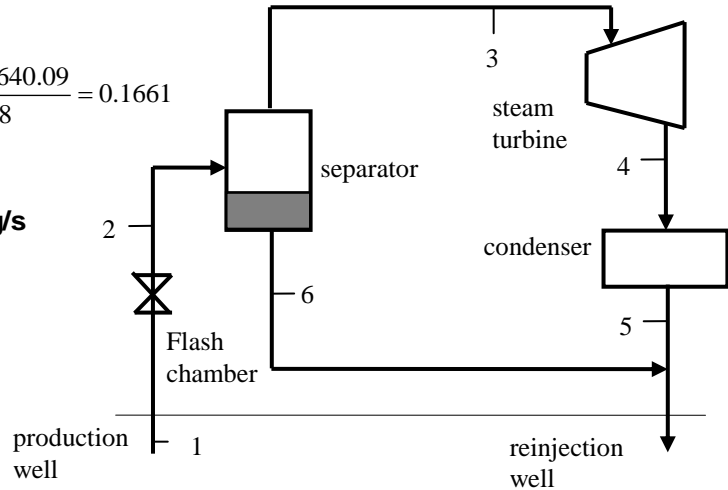

18-92 A double-flash geothermal power plant uses hot geothermal water at 230°C as the heat source. The temperature of the steam at the exit of the second flash chamber, the power produced from the second turbine, and the thermal efficiency of the plant are to be determined.

Assumptions 1 Steady operating conditions exist. 2 Kinetic and potential energy changes are negligible.

Analysis (a) We use properties of water for geothermal water (Tables A-4 through A-6)

$$\left. \begin{array}{l} T_1 = 230^\circ\text{C} \\ x_1 = 0 \end{array} \right\} h_1 = 990.14 \text{ kJ/kg}$$

$$\left. \begin{array}{l} P_2 = 500 \text{ kPa} \\ h_2 = h_1 = 990.14 \text{ kJ/kg} \end{array} \right\} x_2 = 0.1661$$

$$\dot{m}_3 = x_2 \dot{m}_1 = (0.1661)(230 \text{ kg/s}) = 38.20 \text{ kg/s}$$

$$\dot{m}_6 = \dot{m}_1 - \dot{m}_3 = 230 - 0.1661 = 191.80 \text{ kg/s}$$

$$\left. \begin{array}{l} P_3 = 500 \text{ kPa} \\ x_3 = 1 \end{array} \right\} h_3 = 2748.1 \text{ kJ/kg}$$

$$\left. \begin{array}{l} P_4 = 10 \text{ kPa} \\ x_4 = 0.90 \end{array} \right\} h_4 = 2344.7 \text{ kJ/kg}$$

$$\left. \begin{array}{l} P_6 = 500 \text{ kPa} \\ x_6 = 0 \end{array} \right\} h_6 = 640.09 \text{ kJ/kg}$$

$$\left. \begin{array}{l} P_7 = 150 \text{ kPa} \\ h_7 = h_6 \end{array} \right\} T_7 = \mathbf{111.35^\circ\text{C}}$$

$$\left. \begin{array}{l} x_7 = 0.0777 \end{array} \right\}$$

$$\left. \begin{array}{l} P_8 = 150 \text{ kPa} \\ x_8 = 1 \end{array} \right\} h_8 = 2693.1 \text{ kJ/kg}$$

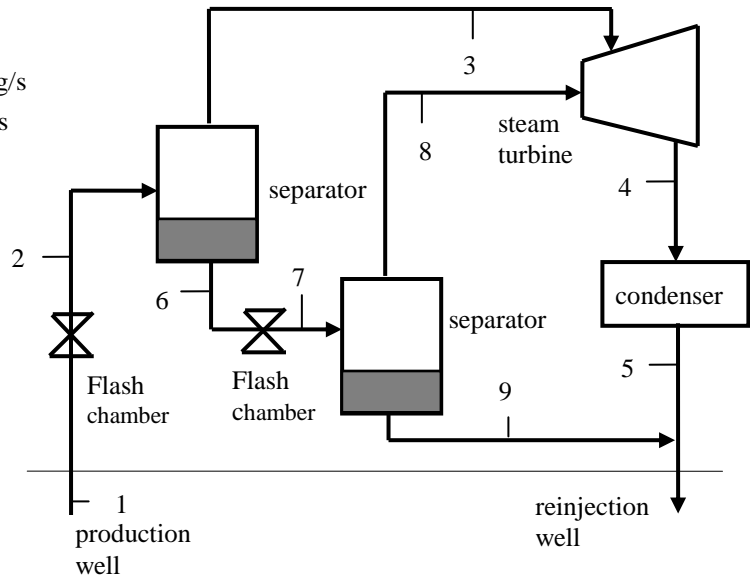

(b) The mass flow rate at the lower stage of the turbine is

$$\dot{m}_8 = x_7 \dot{m}_6 = (0.0777)(191.80 \text{ kg/s}) = 14.90 \text{ kg/s}$$

The power outputs from the high and low pressure stages of the turbine are

$$\dot{W}_{T1,\text{out}} = \dot{m}_3(h_3 - h_4) = (38.20 \text{ kJ/kg})(2748.1 - 2344.7) \text{ kJ/kg} = 15,410 \text{ kW}$$

$$\dot{W}_{T2,\text{out}} = \dot{m}_8(h_8 - h_4) = (14.90 \text{ kJ/kg})(2693.1 - 2344.7) \text{ kJ/kg} = \mathbf{5191 \text{ kW}}$$

(c) We use saturated liquid state at the standard temperature for the dead state enthalpy

$$\left. \begin{array}{l} T_0 = 25^\circ\text{C} \\ x_0 = 0 \end{array} \right\} h_0 = 104.83 \text{ kJ/kg}$$

$$\dot{E}_{\text{in}} = \dot{m}_1(h_1 - h_0) = (230 \text{ kg/s})(990.14 - 104.83) \text{ kJ/kg} = 203,621 \text{ kW}$$

$$\eta_{\text{th}} = \frac{\dot{W}_{T,\text{out}}}{\dot{E}_{\text{in}}} = \frac{15,410 + 5193}{203,621} = 0.101 = \mathbf{10.1\%}$$

18-93 A combined flash-binary geothermal power plant uses hot geothermal water at 230°C as the heat source. The mass flow rate of isobutane in the binary cycle, the net power outputs from the steam turbine and the binary cycle, and the thermal efficiencies for the binary cycle and the combined plant are to be determined.

Assumptions 1 Steady operating conditions exist. 2 Kinetic and potential energy changes are negligible.

Analysis (a) We use properties of water for geothermal water (Tables A-4 through A-6)

$$\left. \begin{array}{l} T_1 = 230^\circ\text{C} \\ x_1 = 0 \end{array} \right\} h_1 = 990.14 \text{ kJ/kg}$$

$$\left. \begin{array}{l} P_2 = 500 \text{ kPa} \\ h_2 = h_1 = 990.14 \text{ kJ/kg} \end{array} \right\} x_2 = 0.1661$$

$$\dot{m}_3 = x_2 \dot{m}_1 = (0.1661)(230 \text{ kg/s}) = 38.20 \text{ kg/s}$$

$$\dot{m}_6 = \dot{m}_1 - \dot{m}_3 = 230 - 38.20 = 191.80 \text{ kg/s}$$

$$\left. \begin{array}{l} P_3 = 500 \text{ kPa} \\ x_3 = 1 \end{array} \right\} h_3 = 2748.1 \text{ kJ/kg}$$

$$\left. \begin{array}{l} P_4 = 10 \text{ kPa} \\ x_4 = 0.90 \end{array} \right\} h_4 = 2344.7 \text{ kJ/kg}$$

$$\left. \begin{array}{l} P_6 = 500 \text{ kPa} \\ x_6 = 0 \end{array} \right\} h_6 = 640.09 \text{ kJ/kg}$$

$$\left. \begin{array}{l} T_7 = 90^\circ\text{C} \\ x_7 = 0 \end{array} \right\} h_7 = 377.04 \text{ kJ/kg}$$

The isobutane properties are obtained from EES:

$$\left. \begin{array}{l} P_8 = 3250 \text{ kPa} \\ T_8 = 145^\circ\text{C} \end{array} \right\} h_8 = 755.05 \text{ kJ/kg}$$

$$\left. \begin{array}{l} P_9 = 400 \text{ kPa} \\ T_9 = 80^\circ\text{C} \end{array} \right\} h_9 = 691.01 \text{ kJ/kg}$$

$$\left. \begin{array}{l} P_{10} = 400 \text{ kPa} \\ x_{10} = 0 \end{array} \right\} \begin{array}{l} h_{10} = 270.83 \text{ kJ/kg} \\ v_{10} = 0.001839 \text{ m}^3/\text{kg} \end{array}$$

$$w_{p,\text{in}} = v_{10}(P_{11} - P_{10})/\eta_p$$

$$= (0.001839 \text{ m}^3/\text{kg})(3250 - 400) \text{ kPa} \left(\frac{1 \text{ kJ}}{1 \text{ kPa} \cdot \text{m}^3} \right) / 0.90$$

$$= 5.82 \text{ kJ/kg.}$$

$$h_{11} = h_{10} + w_{p,\text{in}} = 270.83 + 5.82 = 276.65 \text{ kJ/kg}$$

An energy balance on the heat exchanger gives

$$\dot{m}_6 (h_6 - h_7) = \dot{m}_{\text{iso}} (h_8 - h_{11})$$

$$(191.81 \text{ kg/s})(640.09 - 377.04) \text{ kJ/kg} = \dot{m}_{\text{iso}} (755.05 - 276.65) \text{ kJ/kg} \longrightarrow \dot{m}_{\text{iso}} = \mathbf{105.46 \text{ kg/s}}$$

(b) The power outputs from the steam turbine and the binary cycle are

$$\dot{W}_{\text{T,steam}} = \dot{m}_3 (h_3 - h_4) = (38.19 \text{ kg/s})(2748.1 - 2344.7) \text{ kJ/kg} = \mathbf{15,410 \text{ kW}}$$

$$\dot{W}_{\text{T,iso}} = \dot{m}_{\text{iso}} (h_8 - h_9) = (105.46 \text{ kg/s})(755.05 - 691.01) \text{ kJ/kg} = 6753 \text{ kW}$$

$$\dot{W}_{\text{net,binary}} = \dot{W}_{\text{T,iso}} - \dot{m}_{\text{iso}} w_{p,\text{in}} = 6753 - (105.46 \text{ kg/s})(5.82 \text{ kJ/kg}) = \mathbf{6139 \text{ kW}}$$

(c) The thermal efficiencies of the binary cycle and the combined plant are

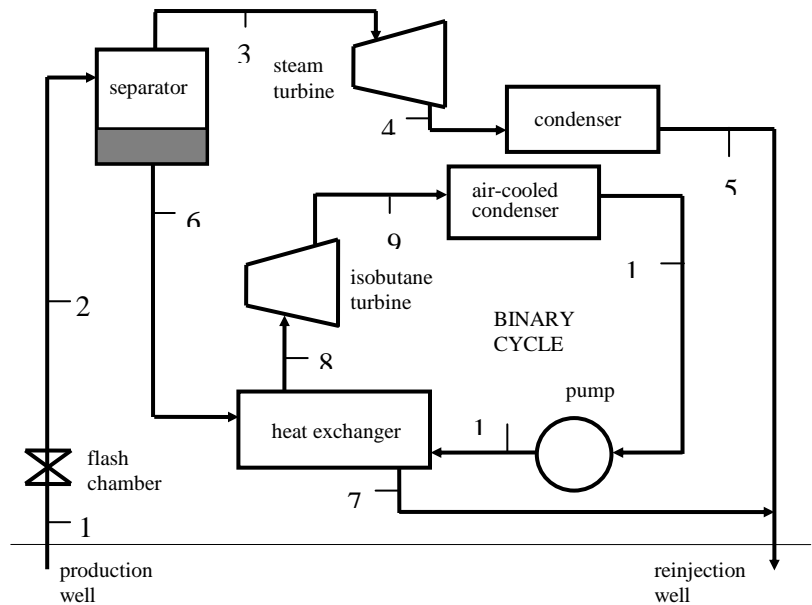

$$\dot{Q}_{\text{in,binary}} = \dot{m}_{\text{iso}}(h_8 - h_{11}) = (105.46 \text{ kJ/kg})(755.05 - 276.65) \text{ kJ/kg} = 50,454 \text{ kW}$$

$$\eta_{\text{th,binary}} = \frac{\dot{W}_{\text{net,binary}}}{\dot{Q}_{\text{in,binary}}} = \frac{6139}{50,454} = 0.122 = \mathbf{12.2\%}$$

$$\left. \begin{array}{l} T_0 = 25^\circ\text{C} \\ x_0 = 0 \end{array} \right\} h_0 = 104.83 \text{ kJ/kg}$$

$$\dot{E}_{\text{in}} = \dot{m}_1(h_1 - h_0) = (230 \text{ kJ/kg})(990.14 - 104.83) \text{ kJ/kg} = 203,622 \text{ kW}$$

$$\eta_{\text{th,plant}} = \frac{\dot{W}_{\text{T,steam}} + \dot{W}_{\text{net,binary}}}{\dot{E}_{\text{in}}} = \frac{15,410 + 6139}{203,622} = 0.106 = \mathbf{10.6\%}$$

18-94 A binary geothermal cogeneration plant produces power and provides space heating. The rate of space heating provided by the system, the mass flow rate of water used for space heating, the thermal efficiency of the power plant, and the utilization factor for the entire cogeneration plant are to be determined.

Assumptions 1 Steady operating conditions exist. 2 Kinetic and potential energy changes are negligible.

Properties The specific heat of water at room temperature is $c_p = 4.18 \text{ kJ/kg}\cdot^\circ\text{C}$.

Analysis (a) The rate of space heating provided by the system is determined from

$$\dot{Q}_{\text{heat}} = \dot{m}c_p(T_6 - T_7) = (175 \text{ kg/s})(4.18 \text{ kJ/kg}\cdot^\circ\text{C})(85 - 65)^\circ\text{C} = \mathbf{14,630 \text{ kW}}$$

The mass flow rate of fresh water is

$$\begin{aligned}\dot{Q}_{\text{heat}} &= \dot{m}_w c_p (T_9 - T_8) \\ 14,630 \text{ kW} &= \dot{m}_w (4.18 \text{ kJ/kg}\cdot^\circ\text{C})(75 - 50)^\circ\text{C} \\ \dot{m}_w &= \mathbf{140 \text{ kg/s}}\end{aligned}$$

(a) The rate of heat input to the power plant is

$$\dot{Q}_{\text{in}} = \dot{m}c_p(T_5 - T_6) = (175 \text{ kg/s})(4.18 \text{ kJ/kg}\cdot^\circ\text{C})(165 - 85)^\circ\text{C} = 58,520 \text{ kW}$$

The thermal efficiency of the power plant and the utilization factor of the cogeneration plant are determined from their definitions to be

$$\begin{aligned}\eta_{\text{th}} &= \frac{\dot{W}_{\text{out}}}{\dot{Q}_{\text{in}}} = \frac{6900 \text{ kW}}{58,520 \text{ kW}} = 0.1179 = \mathbf{11.8\%} \\ \varepsilon_u &= \frac{\dot{W}_{\text{out}} + \dot{Q}_{\text{heat}}}{\dot{Q}_{\text{in}}} = \frac{6900 \text{ kW} + 14,630 \text{ kW}}{58,520 \text{ kW}} = 0.3679 = \mathbf{36.8\%}\end{aligned}$$

18-95 A binary geothermal cogeneration plant produces power and provides space heating. The amount of money than can be made by selling geothermal heat is to be determined.

Assumptions 1 Steady operating conditions exist. 2 Kinetic and potential energy changes are negligible.

Properties The specific heat of water at room temperature is $c_p = 4.18 \text{ kJ/kg}\cdot^\circ\text{C}$.

Analysis The amount of natural gas used to supply space heating at a rate of 14,630 kW is determined from

$$\text{Amount of natural gas} = \frac{\dot{Q}_{\text{heat}} \times \text{Operating hours}}{\eta_{\text{boiler}}} = \frac{(14,630 \text{ kJ/s})(4200 \times 3600 \text{ s})}{0.85} \left(\frac{1 \text{ therm}}{105,500 \text{ kJ}} \right) = 234,916 \text{ therms}$$

The revenue generated by selling the geothermal heat is

$$\begin{aligned}\text{Revenue} &= (1 - f_{\text{discount}}) \times \text{Amount of natural gas} \times \text{Unit price of natural gas} \\ &= (1 - 0.25)(234,916 \text{ therms})(\$1.3/\text{therm}) \\ &= \mathbf{\$229,000}\end{aligned}$$

Biomass Energy

18-96C Biomass is mostly produced from agriculture and forest products and residues, energy crops, and algae. Organic component of municipal and industrial wastes and the fuel produced from food processing waste such as used cooking oil are also considered biomass. Despite relatively long period of times involved in growing crops and trees, they can be re-grown by planting, and therefore biomass is considered to be a renewable energy source.

18-97C Growing of crops and trees as well as the conversion to liquid and gaseous fuels involves the consumption of energy in the form of electricity and fossil fuels such as coal, oil, and natural gas. The consumption of fossil fuels is accompanied by the pollutant and greenhouse emissions. Therefore, the renewability and cleanliness of biomass are not as good as other renewables such as solar, geothermal, or wind.

18-98C In **pyrolysis**, biomass is exposed to high temperatures without the presence of air, causing it to decompose.

18-99C The two most common biofuels are ethanol and biodiesel.

18-100C Ethanol has a higher heating value (HHV) of 29,710 kJ/kg while the higher heating value of biodiesel is about 40,700 kJ/kg. Since the heating value of biodiesel is higher, the car using biodiesel will get more mileage.

18-101C The higher heating value of biodiesel is about 40,700 kJ/kg, which is about 9 percent less than that of petroleum diesel (HHV = 44,800 kJ/kg). Since the heating value of petroleum diesel is higher, the car using petroleum diesel will get more mileage. Biodiesel could increase nitrogen oxides emissions compared to petroleum diesel while significantly reducing hydrocarbon, sulfur and carbon monoxide emissions.

18-102C Biogas usually consists of 50 to 80 percent methane (CH_4) and 20 to 50 percent carbon dioxide (CO_2) by volume. It also contains small amounts of hydrogen, carbon monoxide, and nitrogen. Biogas can be produced from biological waste such as animal manure, food waste, and agricultural waste.

18-103C An important class of biomass is produced by households as trash or garbage. This is referred to as **municipal solid waste** (MSW). MSW includes mostly organic materials such as paper, food scraps, wood, and yard trimmings but some fossil content such as plastic also exists. MSW does not include industrial, hazardous, or construction waste.

18-104C Recycling refers to recovery of useful materials such as paper, glass, plastic, and metals from the trash to use to make new products. **Composting**, on the other hand, refers to storing organic waste such as food scraps and yard trimmings under certain conditions to help it break down naturally. The resulting product can be used as a natural fertilizer.

18-105C In **waste to energy** (WTE) option, waste is burned directly for generating steam. This steam is run through a turbine to generate electricity. The second option is known as **landfill-gas-to-energy** (LFGTE), and it involves harvesting biogas (mostly methane) from the buried waste as it decomposes. Biogas is then used as the fuel in an internal combustion engine or gas turbine to generate electricity.

18-106 Sugar beet roots with certain sugar content are used to produce ethanol. The amount of ethanol that can be produced from 100 kg of sugar beet roots is to be determined.

Properties The molar masses of C, H₂, and O₂ are 12 kg/kmol, 2 kg/kmol, and 32 kg/kmol, respectively (Table A-1).

Analysis The molar mass of ethanol C₆H₁₂O₆ and sugar C₂H₅OH are

$$M_{\text{C}_6\text{H}_{12}\text{O}_6} = 6 \times 12 + 12 \times 2 + 6 \times 32 = 180 \text{ kg/kmol}$$

$$M_{\text{C}_2\text{H}_5\text{OH}} = 2 \times 12 + 5 \times 2 + 1 \times 32 = 46 \text{ kg/kmol}$$

The mass of sugar in 100 kg of sugar beet roots is

$$m_{\text{sugar}} = m_{\text{sugar}}^f \times m_{\text{beet}} = (0.20)(100 \text{ kg}) = 20 \text{ kg}$$

The ratio of mass of ethanol to the mass of sugar is obtained from the chemical reaction $\text{C}_6\text{H}_{12}\text{O}_6 \rightarrow 2 \text{C}_2\text{H}_5\text{OH} + 2 \text{CO}_2$ is

$$\frac{m_{\text{ethanol}}}{m_{\text{sugar}}} = \frac{2M_{\text{C}_6\text{H}_{12}\text{O}_6}}{M_{\text{C}_2\text{H}_5\text{OH}}} = \frac{(2 \times 180) \text{ kg}}{46 \text{ kg}} = 0.5111$$

The mass of the ethanol produced is

$$m_{\text{ethanol}} = m_{\text{sugar}} \frac{m_{\text{ethanol}}}{m_{\text{sugar}}} = (20 \text{ kg})(0.5111) = \mathbf{10.2 \text{ kg}}$$

18-107E Methanol is to replace gasoline in an internal combustion engine. The maximum power output from the engine with methanol as the fuel is to be estimated and the rates of gasoline and methanol consumptions are to be determined.

Assumptions 1 Combustion is complete. 2 The combustion products contain CO_2 , H_2O , O_2 , and N_2 only.

Properties The molar masses of C, H_2 , and O_2 are 12 lbm/lbmol, 2 lbm/lbmol, and 32 lbm/lbmol, respectively (Table A-1E). The lower heating values of gasoline and ethanol are 18,490 Btu/lbm and 8620 Btu/lbm, respectively.

Analysis The balanced reaction equation with stoichiometric air is

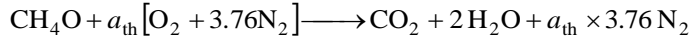

The stoichiometric coefficient a_{th} is determined from an O_2 balance:

$$0.5 + a_{\text{th}} = 1 + 1 \longrightarrow a_{\text{th}} = 1.5$$

Substituting,

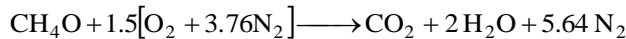

Therefore, the air-fuel ratio for this stoichiometric reaction is

$$\text{AF} = \frac{m_{\text{air}}}{m_{\text{fuel}}} = \frac{(1.5 \times 4.76 \times 29) \text{ lbm}}{(1 \times 12 + 4 \times 1 + 1 \times 16) \text{ lbm}} = \frac{207.1 \text{ lbm}}{32 \text{ lbm}} = 6.471$$

For a given engine size (i.e., volume), the power produced is proportional to the heating value of the fuel and inversely proportional to the air-fuel ratio. The ratio of power produced by gasoline engine to that of methanol engine is expressed as

$$\frac{\dot{W}_{\text{gasoline}}}{\dot{W}_{\text{methanol}}} = \frac{\text{LHV}_{\text{gasoline}}}{\text{LHV}_{\text{methanol}}} \times \frac{\text{AF}_{\text{methanol}}}{\text{AF}_{\text{gasoline}}} = \left(\frac{18,490 \text{ Btu/lbm}}{8620 \text{ Btu/lbm}} \right) \left(\frac{6.471}{14.6} \right) = 0.9507$$

Then, the maximum power by the engine with ethanol as the fuel becomes

$$\dot{W}_{\text{methanol}} = \dot{W}_{\text{gasoline}} \frac{\dot{W}_{\text{methanol}}}{\dot{W}_{\text{gasoline}}} = \dot{W}_{\text{gasoline}} \frac{1}{0.9507} = \frac{200 \text{ hp}}{0.9507} = \mathbf{210.4 \text{ hp}}$$

The thermal efficiency of this engine is defined as the net power output divided by the rate of heat input, which is equal to the heat released by the combustion of fuel:

$$\eta_{\text{th}} = \frac{\dot{W}_{\text{out}}}{\dot{Q}_{\text{in}}} = \frac{\dot{W}_{\text{out}}}{\dot{m}_{\text{fuel}} \times \text{LHV} \times \eta_c}$$

Note that the lower heating value is used in the analysis of internal combustion engines since the water in the exhaust is normally in the vapor phase. Solving the above equation for the rates of gasoline and ethanol consumption, we obtain

$$\dot{m}_{\text{gasoline}} = \frac{\dot{W}_{\text{gasoline}}}{\eta_{\text{th}} \times \text{LHV}_{\text{gasoline}} \times \eta_c} = \frac{200 \text{ hp}}{(0.40)(18,490 \text{ Btu/lbm})(1)} \left(\frac{42.41 \text{ Btu/min}}{1 \text{ hp}} \right) = \mathbf{1.15 \text{ lbm/min}}$$

$$\dot{m}_{\text{methanol}} = \frac{\dot{W}_{\text{methanol}}}{\eta_{\text{th}} \times \text{LHV}_{\text{methanol}} \times \eta_c} = \frac{210.4 \text{ hp}}{(0.40)(8620 \text{ Btu/lbm})(1)} \left(\frac{42.41 \text{ Btu/min}}{1 \text{ hp}} \right) = \mathbf{2.59 \text{ lbm/min}}$$

18-108 A homeowner is to replace the existing natural gas furnace with a wood pellet furnace. The savings due to this replacement are to be determined.

Assumptions **1** Combustion is complete. **2** Combustion efficiency for both furnace is 100 percent.

Analysis The unit price of useful heat supplied by the furnace in the case of natural gas, in \$/MJ, is

$$\text{Unit price of heat (gas)} = \frac{\text{Unit price of gas}}{\eta_{\text{boiler,gas}}} = \frac{\$1.35/\text{therm}}{0.90} \left(\frac{1 \text{ therm}}{105.5 \text{ MJ}} \right) = \$0.01422 / \text{MJ}$$

The unit price of useful heat supplied by the furnace in the case of pellet, in \$/MJ, is

$$\text{Unit price of heat (pellet)} = \frac{\text{Unit price of pellet}}{\eta_{\text{boiler,pellet}} \times \text{HV}} = \frac{\$0.15/\text{kg}}{(0.80)(20 \text{ MJ/kg})} = \$0.009375 / \text{MJ}$$

Using these unit prices, the annual fuel cost in the case of pellet furnace would be

$$\text{Annual pellet cost} = \text{Annual gas cost} \times \frac{\text{Unit price of heat (pellet)}}{\text{Unit price of heat (gas)}} = (\$3000) \frac{\$0.009375 / \text{MJ}}{\$0.01422 / \text{MJ}} = \$1978$$

Therefore, the savings due to this replacement would be

$$\text{Savings} = \text{Annual gas cost} - \text{Annual pellet cost} = \$3000 - \$1978 = \mathbf{\$1022}$$

18-109 Municipal solid waste (MSW) is burned directly in a boiler to generate saturated steam and this steam is run through a turbine to generate power. The amount of steam and electricity generated and the revenue generated by selling the electricity are to be determined.

Assumptions 1 Steady operating conditions exist. 2 Kinetic and potential energy changes are negligible.

Analysis The properties of water at the boiler inlet (state 1), boiler exit and turbine inlet (state 2), and turbine exit (state 3) are obtained from steam tables (Tables A-4 through A-6)

$$\left. \begin{array}{l} T_1 = 20^\circ\text{C} \\ x_1 = 0 \end{array} \right\} h_1 = 83.91 \text{ kJ/kg}$$

$$\left. \begin{array}{l} T_2 = 200^\circ\text{C} \\ x_2 = 1 \end{array} \right\} \begin{array}{l} h_2 = 2792.0 \text{ kJ/kg} \\ s_2 = 6.4302 \text{ kJ/kg} \cdot \text{K} \end{array}$$

$$\left. \begin{array}{l} P_3 = 100 \text{ kPa} \\ s_3 = s_2 \end{array} \right\} h_{3s} = 2328.8 \text{ kJ/kg}$$

The actual enthalpy at the turbine exit is determined from the definition of isentropic efficiency as

$$\eta_T = \frac{h_2 - h_3}{h_2 - h_{3s}} \longrightarrow 0.85 = \frac{2792.0 - h_3}{2792.0 - 2328.8} \longrightarrow h_3 = 2398.3 \text{ kJ/kg}$$

From the definition of the boiler efficiency,

$$\begin{aligned} \eta_{\text{boiler}} &= \frac{Q_{\text{useful}}}{Q_{\text{in}}} = \frac{m_{\text{steam}}(h_2 - h_1)}{m_{\text{MSW}} \times \text{HV}_{\text{MSW}}} \\ 0.75 &= \frac{m_{\text{steam}}(2792.0 - 83.91) \text{ kJ/kg}}{(10,000 \text{ kg})(18,000 \text{ kJ/kg})} \\ m_{\text{steam}} &= \mathbf{49,850 \text{ kg}} \end{aligned}$$

The electric power output from the turbine is

$$W_{\text{electric}} = \eta_{\text{generator}}(h_2 - h_3) = (0.95)(2792.0 - 2398.3) \text{ kJ/kg} \left(\frac{1 \text{ kWh}}{3600 \text{ kJ}} \right) = \mathbf{5180 \text{ kWh}}$$

The revenue that can be generated by selling the electricity is

$$\begin{aligned} \text{Revenue} &= W_{\text{electric}} \times \text{Unit price of electricity} \\ &= (5180 \text{ kWh})(\$0.11/\text{kWh}) \\ &= \mathbf{\$570} \end{aligned}$$

Review Problems

18-110 A solar collector provides the hot water needs of a family. The annual natural gas and cost savings due to solar water heating are to be determined.

Properties The specific heat of water at room temperature is $c_p = 4.18 \text{ kJ/kg}\cdot^\circ\text{C}$.

Analysis The amount of solar water heating during a month period is

$$Q = mc_p(T_1 - T_2) = (6000 \text{ kg/month})(4.18 \text{ kJ/kg}\cdot^\circ\text{C})(60 - 20)^\circ\text{C} = 1.003 \times 10^6 \text{ kJ/month}$$

The amount of gas that would be consumed (or saved) during the 8 month period is

$$\text{Gas savings} = \frac{Q}{\eta_{\text{heater}}} = (8 \text{ months}) \frac{1.003 \times 10^{11} \text{ kJ/month}}{0.88} \left(\frac{1 \text{ therm}}{105,500 \text{ kJ}} \right) = \mathbf{86.44 \text{ therms}}$$

The corresponding cost savings is

$$\begin{aligned} \text{Cost savings} &= \text{Gas savings} \times \text{Unit price of geothermal heat} \\ &= (86.44 \text{ therms})(\$1.35/\text{therm}) \\ &= \mathbf{\$116.7} \end{aligned}$$

18-111 Two concentrating collectors with given characteristics are considered. The solar irradiation rate for collector B to have the same efficiency as collector A and the efficiency change of collector A for a change in irradiation are to be determined.

Analysis (a) The collector efficiency of collector A is determined from

$$\eta_{c,A} = \eta_{ar} - U_A \frac{T_c - T_a}{\text{CR} \times G_A} = 0.88 - (2.5 \text{ W/m}^2 \cdot ^\circ\text{C}) \frac{(145 - 27)^\circ\text{C}}{(7)(600 \text{ W/m}^2)} = 0.8098$$

Using the same relation for collector B at the same collector efficiency, we obtain the necessary solar irradiation rate:

$$\begin{aligned} \eta_{c,B} &= \eta_{ar} - U_B \frac{T_c - T_a}{\text{CR} \times G_B} \\ 0.8098 &= 0.88 - (3.5 \text{ W/m}^2 \cdot ^\circ\text{C}) \frac{(145 - 27)^\circ\text{C}}{(7)G_B} \\ G_B &= \mathbf{840 \text{ W/m}^2} \end{aligned}$$

(b) The collector efficiency of collector A for a solar irradiation of 900 W/m^2 is

$$\eta_{c,A} = \eta_{ar} - U_A \frac{T_c - T_a}{\text{CR} \times G_A} = 0.88 - (2.5 \text{ W/m}^2 \cdot ^\circ\text{C}) \frac{(145 - 27)^\circ\text{C}}{(7)(900 \text{ W/m}^2)} = 0.8332$$

The change in the efficiency of collector A is then

$$\Delta\eta_{c,A} = 0.8332 - 0.8098 = 0.02341 = \mathbf{2.34 \text{ percent}}$$

18-112 The initial cost of a solar power plant is given. The payback period of the investment is to be determined.

Analysis The total cost of this power plant is

$$\text{Plant cost} = \text{Unit cost} \times \dot{W}_{\text{out}} = (\$14,000/\text{kW})(10,000 \text{ kW}) = \$1.400 \times 10^8$$

The annual revenue from selling the electricity produced is

$$\begin{aligned} \text{Annual revenue} &= \dot{W}_{\text{out}} \times \text{Unit price} \times \text{Operating hours} \\ &= (10,000 \text{ kW})(\$0.09/\text{kW})(5000 \text{ h/year}) \\ &= \$4.500 \times 10^6/\text{year} \end{aligned}$$

The simple payback period is then

$$\text{Payback period} = \frac{\text{Plant cost}}{\text{Annual revenue}} = \frac{\$1.400 \times 10^8}{\$4.500 \times 10^6/\text{year}} = \mathbf{31.1 \text{ years}}$$

That is, this plant pays for itself in 31 years, which is not unexpected for solar power plants.

18-113 Two cities are considered for solar power production. The amount of electricity that can be produced in each city are to be determined.

Analysis Using the average daily solar radiation values on a horizontal surface is obtained from [Table 18-3](#) for each city as

$$G_{\text{avg,Fl}} = (17,380 \text{ kJ/m}^2 \cdot \text{day})(365 \text{ days}) = 6.344 \times 10^6 \text{ kJ/m}^2$$

$$G_{\text{avg,At}} = (16,430 \text{ kJ/m}^2 \cdot \text{day})(365 \text{ days}) = 5.997 \times 10^6 \text{ kJ/m}^2$$

Noting that the average thermal efficiency is 18 percent and the total collector area is 30,000 m², the amount of electricity that can be produced in each city would be

$$\text{Amount of electricity (Fl)} = \eta_{\text{th}} A G_{\text{avg,Fl}} = (0.18)(30,000 \text{ m}^2)(6.344 \times 10^6 \text{ kJ/m}^2) \left(\frac{1 \text{ kWh}}{3600 \text{ s}} \right) = \mathbf{9.516 \times 10^7 \text{ kWh}}$$

$$\text{Amount of electricity (At)} = \eta_{\text{th}} A G_{\text{avg,At}} = (0.18)(30,000 \text{ m}^2)(5.997 \times 10^6 \text{ kJ/m}^2) \left(\frac{1 \text{ kWh}}{3600 \text{ s}} \right) = \mathbf{8.995 \times 10^7 \text{ kWh}}$$

18-114 The initial cost of a solar photovoltaic cell system for a house is given. The payback period of this system is to be determined.

Analysis The total cost of the photovoltaic system is

$$\text{System cost} = \text{Unit cost} \times \dot{W}_{\text{out}} = (\$1.3/\text{W})(6000 \text{ W}) = \$7800$$

The current annual electricity cost to the homeowner is

$$\begin{aligned} \text{Annual electricity cost} &= 12 \text{ months/year} \times \text{Monthly bill} \\ &= (12 \text{ months})(\$125/\text{month}) \\ &= \$1500/\text{year} \end{aligned}$$

The homeowner can meet approximately 80 percent of the electricity needs of the house by the solar system.

$$\text{Annual electricity savings} = 0.80 \times \text{Annual electricity cost} = (0.80)(\$1500/\text{year}) = \$1200/\text{year}$$

Then, the simple payback period is determined from

$$\text{Payback period} = \frac{\text{System cost}}{\text{Annual electricity savings}} = \frac{\$7800}{\$1200/\text{year}} = \mathbf{6.5 \text{ years}}$$

That is, this photovoltaic system pays for itself in 6.5 years.

18-115 The ratio of power generated in two locations with different wind velocities is to be determined.

Assumptions Wind flows steadily at the specified speed.

Properties The density of air is same in two locations.

Analysis The wind power potential is expressed for both locations to be

$$\dot{W}_{\text{available1}} = \frac{1}{2} \rho A V_1^3$$

$$\dot{W}_{\text{available2}} = \frac{1}{2} \rho A V_2^3$$

The ratio of power generated from location A and location B is then

$$\frac{\dot{W}_{\text{available1}}}{\dot{W}_{\text{available2}}} = \frac{\frac{1}{2} \rho A V_1^3}{\frac{1}{2} \rho A V_2^3} = \frac{V_1^3}{V_2^3} = \frac{(9 \text{ m/s})^3}{(6 \text{ m/s})^3} = \mathbf{3.375}$$

18-116 An investor to install 40 wind turbines with a specified average wind speed. The payback period of this investment is to be determined.

Assumptions Wind flows steadily at the specified speed.

Properties The density of air is given to be $\rho = 1.18 \text{ kg/m}^3$.

Analysis The blade span area is

$$A = \pi D^2 / 4 = \pi (18 \text{ m})^2 / 4 = 254.5 \text{ m}^2$$

The wind power potential for one turbine is

$$\dot{W}_{\text{available}} = \frac{1}{2} \rho A V_1^3 = \frac{1}{2} (1.18 \text{ kg/m}^3)(254.5 \text{ m}^2)(7.2 \text{ m/s})^3 \left(\frac{1 \text{ kJ/kg}}{1000 \text{ m}^2/\text{s}^2} \right) = 56.04 \text{ kW}$$

The electric power generated is

$$\dot{W}_{\text{electric}} = \eta_{\text{wt,overall}} \dot{W}_{\text{available}} = (0.33)(56.04 \text{ kW}) = 18.49 \text{ kW}$$

The amount of electricity produced is determined from

$$W_{\text{electric}} = \dot{W}_{\text{electric}} \times \text{Operating hours} = (18.49 \text{ kW})(6000 \text{ h}) = 110,940 \text{ kWh}$$

The annual revenue generated by 40 turbines is

$$\begin{aligned} \text{Annual revenue} &= n_{\text{turbine}} \times W_{\text{electric}} \times \text{Unit price of electricity} \\ &= (40)(110,940 \text{ kWh})(\$0.075/\text{kWh}) \\ &= \$332,820/\text{year} \end{aligned}$$

The payback period of this investment is

$$\text{Payback period} = \frac{\text{Total initial cost}}{\text{Annual revenue}} = \frac{\$1,200,000}{\$332,820/\text{year}} = \mathbf{3.61 \text{ years}}$$

18-117 A school is considering installing wind turbines to meet its electricity needs. The required average velocity of wind is to be determined.

Assumptions Wind flows steadily at the specified speed.

Properties The density of air is given to be $\rho = 1.2 \text{ kg/m}^3$.

Analysis The amount of electricity used by the school per year is determine from

$$W_{\text{electric}} = \frac{\text{Annual electricity cost}}{\text{Unit price of electricity}} = \frac{\$23,000/\text{year}}{\$0.11/\text{kWh}} = 209,090 \text{ kWh}$$

The average rate of electrical power is

$$\dot{W}_{\text{electric}} = \frac{W_{\text{electric}}}{\text{Operating hours}} = \frac{110,940 \text{ kWh}}{7500 \text{ h}} = 27.88 \text{ kW}$$

The available wind power is

$$\dot{W}_{\text{available}} = \frac{\dot{W}_{\text{electric}}}{\eta_{\text{wt, overall}}} = \frac{27.88 \text{ kW}}{0.30} = 92.93 \text{ kW}$$

The blade span area is

$$A = \pi D^2 / 4 = \pi (20 \text{ m})^2 / 4 = 314.2 \text{ m}^2$$

The average wind velocity is determined from available wind power relation:

$$\begin{aligned} \dot{W}_{\text{available}} &= \frac{1}{2} \rho A V^3 \\ 92.93 \text{ kW} &= \frac{1}{2} (1.2 \text{ kg/m}^3) (314.2 \text{ m}^2) V^3 \left(\frac{1 \text{ kJ/kg}}{1000 \text{ m}^2/\text{s}^2} \right) \\ V &= \mathbf{7.90 \text{ m/s}} \end{aligned}$$

18-118 A school is considering installing wind turbines to meet its electricity needs. The required average velocity of wind is to be determined.

Assumptions Wind flows steadily at the specified speed.

Properties The density of air is given to be $\rho = 1.2 \text{ kg/m}^3$.

Analysis The amount of electricity used by the school per year is determine from

$$W_{\text{electric}} = \frac{\text{Annual electricity cost}}{\text{Unit price of electricity}} = \frac{\$23,000/\text{year}}{\$0.11/\text{kWh}} = 209,090 \text{ kWh}$$

The average rate of electrical power is

$$\dot{W}_{\text{electric}} = \frac{W_{\text{electric}}}{\text{Operating hours}} = \frac{110,940 \text{ kWh}}{7500 \text{ h}} = 27.88 \text{ kW}$$

The available wind power is

$$\dot{W}_{\text{available}} = \frac{\dot{W}_{\text{electric}}}{\eta_{\text{wt, overall}}} = \frac{27.88 \text{ kW}}{0.30} = 92.93 \text{ kW}$$

The blade span area is

$$A = \pi D^2 / 4 = \pi (30 \text{ m})^2 / 4 = 706.9 \text{ m}^2$$

The average wind velocity is determined from available wind power relation:

$$\begin{aligned} \dot{W}_{\text{available}} &= \frac{1}{2} \rho A V^3 \\ 92.93 \text{ kW} &= \frac{1}{2} (1.2 \text{ kg/m}^3) (706.9 \text{ m}^2) V^3 \left(\frac{1 \text{ kJ/kg}}{1000 \text{ m}^2/\text{s}^2} \right) \\ V &= \mathbf{6.03 \text{ m/s}} \end{aligned}$$

18-119 Mechanical energy of a waterfall in a village is to be converted into electricity by a hydraulic turbine. It is to be determined if the proposed turbine can meet electricity needs of the village.

Assumptions 1 The flow is steady. 2 Water level of the waterfall remains constant.

Properties The density of water is taken to be $\rho = 1000 \text{ kg/m}^3 = 1 \text{ kg/L}$.

Analysis The maximum power from the turbine is determined from

$$\begin{aligned}\dot{W}_{\max} &= \dot{m}gH_{\text{gross}} = \rho\dot{V}gH_{\text{gross}} \\ &= (1 \text{ kg/L})(350/60 \text{ L/s})(9.81 \text{ m/s}^2)(80 \text{ m})\left(\frac{1 \text{ kJ/kg}}{1000 \text{ m}^2/\text{s}^2}\right) \\ &= 4.578 \text{ kW}\end{aligned}$$

The electric power output is

$$\dot{W}_{\text{electric}} = \eta_{\text{turbine-gen}}\dot{W}_{\max} = (0.82)(4.578 \text{ kW}) = 3.754 \text{ kW}$$

Noting that the turbine will operate nonstop throughout the year, the operating hours in one year is

$$\text{Operating hours} = 365 \times 24 = 8760 \text{ h}$$

The amount of electricity that will be produced per year by the turbine is

$$W_{\text{electric, produced}} = \dot{W}_{\text{electric}} \times \text{Operating hours} = (3.754 \text{ kW})(8760 \text{ h}) = \mathbf{32,885 \text{ kWh}}$$

The current amount of electricity used by the village is

$$W_{\text{electric, consumed}} = \frac{\text{Annual cost of electricity}}{\text{Unit price of electricity}} = \frac{\$4600}{\$0.12/\text{kWh}} = \mathbf{38,333 \text{ kWh}}$$

Therefore, the proposed turbine cannot meet entire electricity needs of the village. However, this may still be a good option as the turbine can meet 86 percent of the electricity needs.

18-120 An investor is to build a hydroelectric power plant. It is to be determined if the plant can pay for itself in 5 years.

Assumptions **1** The flow is steady. **2** Water levels at the reservoir and the discharge site remain constant.

Properties The density of water is taken to be $\rho = 1000 \text{ kg/m}^3 = 1 \text{ kg/L}$.

Analysis The maximum power for one turbine is determined from

$$\begin{aligned}\dot{W}_{\max} &= \dot{m}gH_{\text{gross}} = \rho\dot{V}gH_{\text{gross}} \\ &= (1 \text{ kg/L})(565 \text{ L/s})(9.81 \text{ m/s}^2)(90 \text{ m})\left(\frac{1 \text{ kJ/kg}}{1000 \text{ m}^2/\text{s}^2}\right) \\ &= 498.8 \text{ kW}\end{aligned}$$

The electric power output is

$$\dot{W}_{\text{electric}} = \eta_{\text{plant}}\dot{W}_{\max} = (0.88)(498.8 \text{ kW}) = 439.0 \text{ kW}$$

Noting that the plant operates 8200 h a year, the amount of electricity produced per year by one turbine is

$$W_{\text{electric}} = \dot{W}_{\text{electric}} \times \text{Operating hours} = (439.0 \text{ kW})(8200 \text{ h/year}) = 3,600,000 \text{ kWh/year}$$

Noting that the operating and maintenance expenses of the plant are \$750,000/year, the revenue generated by 10 such turbines is

$$\begin{aligned}\text{Revenue} &= (n_{\text{turbine}} \times W_{\text{electric}} \times \text{Unit price of electricity}) - \text{O \& M Cost} \\ &= [(10)(3,600,000 \text{ kWh/year})(\$0.105/\text{kWh/year})] - \$750,000 \\ &= \mathbf{\$3,030,000\text{year}}\end{aligned}$$

The payback period of this investment is then

$$\text{Payback period} = \frac{\text{Total plant cost}}{\text{Annual revenue}} = \frac{\$24,000,000}{\$3,030,000/\text{year}} = \mathbf{7.92 \text{ years}}$$

This payback period does not satisfy the investor's criterion of 5 years.

18-121 Geothermal water is flashed into a lower pressure in a flash chamber. The temperature and the fractions of liquid and vapor phases after the flashing process are to be determined.

Assumptions 1 Steady operating conditions exist. 2 Kinetic and potential energy changes are negligible.

Analysis The enthalpy of geothermal water at the flash chamber inlet is (Table A-4)

$$\left. \begin{array}{l} T_1 = 210^\circ\text{C} \\ x_1 = 0 \end{array} \right\} h_1 = 897.61 \text{ kJ/kg}$$

A flash chamber is a throttling device across which the enthalpy remains constant. Therefore, the properties at the chamber outlet are (Table A-5)

$$\left. \begin{array}{l} P_2 = 600 \text{ kPa} \\ h_2 = h_1 = 897.61 \text{ kJ/kg} \end{array} \right\} \left. \begin{array}{l} T_2 = \mathbf{158.8^\circ\text{C}} \\ x_2 = \frac{h_2 - h_f}{h_{fg}} = \frac{897.61 - 670.38}{2085.8} = 0.1089 \end{array} \right\}$$

The mass fractions of vapor and liquid phases are

$$\text{mf}_{\text{vapor}} = x_2 = \mathbf{0.1089}$$

$$\text{mf}_{\text{liquid}} = (1 - x_2) = 1 - 0.1089 = \mathbf{0.8911}$$

18-122 The vapor resulting from the flashing process is routed to a steam turbine to produce power. The power output from the turbine is to be determined.

Assumptions 1 Steady operating conditions exist. 2 Kinetic and potential energy changes are negligible.

Analysis The enthalpy of geothermal water at the flash chamber inlet is (Table A-4)

$$\left. \begin{array}{l} T_1 = 210^\circ\text{C} \\ x_1 = 0 \end{array} \right\} h_1 = 897.61 \text{ kJ/kg}$$

A flash chamber is a throttling device across which the enthalpy remains constant. Therefore, the properties at the chamber outlet are (Table A-5)

$$\left. \begin{array}{l} P_2 = 600 \text{ kPa} \\ h_2 = h_1 = 897.61 \text{ kJ/kg} \end{array} \right\} \left. \begin{array}{l} T_2 = 158.8^\circ\text{C} \\ x_2 = \frac{h_2 - h_f}{h_{fg}} = \frac{897.61 - 670.38}{2085.8} = 0.1089 \end{array} \right\}$$

The mass flow rate of steam through the turbine is

$$\dot{m}_3 = x_2 \dot{m}_1 = (0.1089)(50 \text{ kg/s}) = 5.447 \text{ kg/s}$$

The properties of steam at the turbine inlet and exit are (Table A-5)

$$\left. \begin{array}{l} P_3 = 600 \text{ kPa} \\ x_3 = 1 \end{array} \right\} \left. \begin{array}{l} h_3 = 2756.2 \text{ kJ/kg} \\ s_3 = 6.7593 \text{ kJ/kg} \cdot \text{K} \end{array} \right\}$$

$$\left. \begin{array}{l} P_4 = 20 \text{ kPa} \\ s_4 = s_3 \end{array} \right\} h_{4s} = 2226.4 \text{ kJ/kg}$$

The power output from the turbine is

$$\dot{W}_{\text{T,out}} = \eta_T \dot{m}_3 (h_3 - h_{4s}) = (0.88)(5.447 \text{ kg/s})(2756.2 - 2226.4) \text{ kJ/kg} = \mathbf{2539 \text{ kW}}$$

18-123 A single-flash geothermal power plant uses geothermal liquid water as the heat source, and produces power. The thermal efficiency, the second-law efficiency, and the total rate of exergy destroyed in the plant are to be determined.

Assumptions 1 Steady operating conditions exist. 2 Kinetic and potential energy changes are negligible.

Analysis The properties of geothermal water at the inlet of the plant and at the dead state are obtained from steam tables to be

$$T_1 = 150^\circ\text{C, liquid} \longrightarrow h_1 = 632.18 \text{ kJ/kg, } s_1 = 1.8418 \text{ kJ/kg}\cdot\text{K}$$

$$T_0 = 25^\circ\text{C, } P_0 = 1 \text{ atm} \longrightarrow h_0 = 104.92 \text{ kJ/kg, } s_0 = 0.3672 \text{ kJ/kg}\cdot\text{K}$$

The energy of geothermal water may be taken to be maximum heat that can be extracted from the geothermal water, and this may be expressed as the enthalpy difference between the state of geothermal water and dead state:

$$\dot{E}_{\text{in}} = \dot{m}(h_1 - h_0) = (420 \text{ kg/s})[(632.18 - 104.92) \text{ kJ/kg}] = 221,449 \text{ kW}$$

The exergy of geothermal water is

$$\begin{aligned} \dot{X}_{\text{in}} &= \dot{m}[(h_1 - h_0) - T_0(s_1 - s_0)] \\ &= (420 \text{ kg/s})[(632.18 - 104.92) \text{ kJ/kg} - (25 + 273 \text{ K})(1.8418 - 0.3672) \text{ kJ/kg}\cdot\text{K}] \\ &= 36,888 \text{ kW} \end{aligned}$$

The thermal efficiency of the power plant is

$$\eta_{\text{th}} = \frac{\dot{W}_{\text{net,out}}}{\dot{E}_{\text{in}}} = \frac{15,800 \text{ kW}}{221,449 \text{ kW}} = 0.07135 = \mathbf{7.14\%}$$

The exergy efficiency of the plant is the ratio of power produced to the exergy input (or expended) to the plant:

$$\eta_{\text{II}} = \frac{\dot{W}_{\text{net,out}}}{\dot{X}_{\text{in}}} = \frac{15,800 \text{ kW}}{36,888 \text{ kW}} = 0.4283 = \mathbf{42.8\%}$$

The exergy destroyed in this power plant is determined from an exergy balance on the entire power plant to be

$$\begin{aligned} \dot{X}_{\text{in}} - \dot{W}_{\text{net,out}} - \dot{X}_{\text{dest}} &= 0 \\ 36,888 - 15,800 - \dot{X}_{\text{dest}} &= 0 \\ \dot{X}_{\text{dest}} &= \mathbf{21,088 \text{ kW}} \end{aligned}$$

18-124 The higher heating value of biogas with a given composition is to be determined.

Properties The molar masses of C, H₂, and O₂ are 12 kg/kmol, 2 kg/kmol, and 32 kg/kmol, respectively (Table A-1).

Analysis The mole fractions of CH₄ and CO₂ are equal to their volume fractions:

$$y_{\text{CH}_4} = 0.65$$

$$y_{\text{CO}_2} = 0.35$$

We consider 100 kmol of biogas mixture. In this mixture, there are 65 kmol of CH₄ and 35 kmol of CO₂. The mass of CH₄ and CO₂ are

$$m_{\text{CH}_4} = N_{\text{CH}_4} M_{\text{CH}_4} = (65 \text{ kmol})(16 \text{ kg}) = 1040 \text{ kg}$$

$$m_{\text{CO}_2} = N_{\text{CO}_2} M_{\text{CO}_2} = (35 \text{ kmol})(44 \text{ kg}) = 1540 \text{ kg}$$

The total mass of the mixture is

$$m_{\text{total}} = m_{\text{CH}_4} + m_{\text{CO}_2} = 1040 + 1540 = 2580 \text{ kg}$$

The mass fraction of CH₄ is

$$\text{mf}_{\text{CH}_4} = \frac{m_{\text{CH}_4}}{m_{\text{total}}} = \frac{1040 \text{ kg}}{2580 \text{ kg}} = 0.4031$$

The heating value of CO₂ is zero. Therefore, the higher heating value of biogas is

$$\text{HHV}_{\text{biogas}} = \text{mf}_{\text{CH}_4} \times \text{HHV}_{\text{CH}_4} = (0.4031)(55,200 \text{ kJ/kg}) = \mathbf{22,250 \text{ kJ/kg}}$$

FE Exam Problems

18-125 Which renewable energy sources are only used for electricity generation?

- (a) Wind and solar (b) Hydro and solar (c) Solar and geothermal (d) Wind and hydro
 (e) Hydro and geothermal

Answer: (d) Wind and hydro

18-126 Which renewable energy source should not be considered as the manifestation of solar energy in different forms?

- (a) Wind (b) Hydro (c) Ocean wave (d) Biomass (e) Geothermal

Answer: (e) Geothermal

18-127 Solar radiation is incident on a flat-plate collector at a rate of 450 W/m^2 . The product of transmissivity and absorptivity is $\tau\alpha = 0.85$, and the heat loss coefficient of the collector is $4.5 \text{ W/m}^2\cdot^\circ\text{C}$. The ambient air temperature is 10°C . The collector temperature at which the collector efficiency is zero is

- (a) 95°C (b) 104°C (c) 112°C (d) 87°C (e) 73°C

Answer: (a) 95°C

Solution Solved by EES Software. Solutions can be verified by copying-and-pasting the following lines on a blank EES screen. (Similar problems and their solutions can be obtained easily by modifying numerical values).

```
G=450 [W/m^2]
TauAlpha=0.85
U=4.5 [W/m^2-C]
T_a=10 [C]
eta_c=0
eta_c=TauAlpha-U*(T_c-T_a)/G
```

18-128 Solar radiation is incident on a flat-plate collector at a rate of 600 W/m^2 . The glazing has a transmissivity of 0.85 and the absorptivity of absorber plate is 0.92. The heat loss coefficient of the collector is $3.0 \text{ W/m}^2\cdot^\circ\text{C}$. The maximum efficiency of this collector is

- (a) 92% (b) 85% (c) 78% (d) 73% (e) 66%

Answer: (c) 78%

Solution Solved by EES Software. Solutions can be verified by copying-and-pasting the following lines on a blank EES screen. (Similar problems and their solutions can be obtained easily by modifying numerical values).

```
G=600 [W/m^2]
Tau=0.85
Alpha=0.92
U=3.0 [W/m^2-C]
eta_c_max=Tau*Alpha
```

18-129 The efficiency of a solar collector is given by $\eta_c = \tau\alpha - U \frac{T_c - T_a}{G}$. If the collector efficiency is plotted against the term $(T_c - T_a)/G$, a straight line is obtained. The slope of this line is equal to

- (a) U (b) $-U$ (c) $\tau\alpha$ (d) $-\tau\alpha$ (e) U/G

Answer: (b) $-U$

18-130 A solar-power-tower plant produces 450 kW of power when solar radiation is incident at a rate of 1050 W/m^2 . If the efficiency of this solar plant is 17 percent, the total collector area receiving solar radiation is

- (a) 1750 m^2 (b) 2090 m^2 (c) 2520 m^2 (d) 3230 m^2 (e) 3660 m^2

Answer: (c) 2520 m^2

Solution Solved by EES Software. Solutions can be verified by copying-and-pasting the following lines on a blank EES screen. (Similar problems and their solutions can be obtained easily by modifying numerical values).

```
W_dot=450E3 [W]
G=1050 [W/m^2]
eta_th=0.17
eta_th=W_dot/(A_c*G)
```

18-131 In a solar pond, the water temperature is 40°C near the surface and 90°C near the bottom of the pond. The maximum thermal efficiency a solar pond power plant can have is

- (a) 13.8% (b) 17.5% (c) 25.7% (d) 32.4% (e) 55.5%

Answer: (a) 13.8%

Solution Solved by EES Software. Solutions can be verified by copying-and-pasting the following lines on a blank EES screen. (Similar problems and their solutions can be obtained easily by modifying numerical values).

```
T_L=40 [C]
T_H=90 [C]
eta_th_max=1-(T_L+273)/(T_H+273)
```

18-132 In a solar cell, the load voltage is 0.5 V and the load current density is determined to be 80 A/m². If the solar irradiation is 650 W/m², the cell efficiency is

- (a) 4.7% (b) 6.2% (c) 7.8% (d) 9.1% (e) 14.2%

Answer: (b) 6.2%

Solution Solved by EES Software. Solutions can be verified by copying-and-pasting the following lines on a blank EES screen. (Similar problems and their solutions can be obtained easily by modifying numerical values).

```
V=0.5 [V]
J_L=80 [A/m^2]
G=650 [W/m^2]
eta_cell=(J_L*V)/G
```

18-133 The power potential of a wind turbine at a wind speed of 5 m/s is 50 kW. The power potential of the same turbine at a velocity of 8 m/s is

- (a) 80 kW (b) 128 kW (c) 180 kW (d) 205 kW (e) 242 kW

Answer: (d) 205 kW

Solution Solved by EES Software. Solutions can be verified by copying-and-pasting the following lines on a blank EES screen. (Similar problems and their solutions can be obtained easily by modifying numerical values).

```
W_dot_1=50 [kW]
V1=5 [m/s]
V2=8 [m/s]
W_dot_2=W_dot_1*(V2^3/V1^3)
```

18-134 Wind is blowing through a turbine at a velocity of 7 m/s. The turbine blade diameter is 25 m and the density of air is 1.15 kg/m^3 . The power potential of the turbine is

- (a) 180 kW (b) 153 kW (c) 131 kW (d) 116 kW (e) 97 kW

Answer: (e) 97 kW

Solution Solved by EES Software. Solutions can be verified by copying-and-pasting the following lines on a blank EES screen. (Similar problems and their solutions can be obtained easily by modifying numerical values).

```
V=7 [m/s]
D=25 [m]
rho=1.15 [kg/m^3]
A=pi*D^2/4
W_dot_available=1/2*rho*A*V^3*Convert(W, kW)
```

18-135 The power potential of a wind turbine at a wind speed of 5 m/s is 100 kW. The blade diameter of this turbine is 40 m. The power potential of a similar turbine with a blade diameter of 60 m at the same velocity is

- (a) 150 kW (b) 225 kW (c) 266 kW (d) 338 kW (e) 390 kW

Answer: (b) 225 kW

Solution Solved by EES Software. Solutions can be verified by copying-and-pasting the following lines on a blank EES screen. (Similar problems and their solutions can be obtained easily by modifying numerical values).

```
V=5 [m/s]
W_dot_1=100 [kW]
D1=40 [m]
D2=60 [m]
W_dot_2=W_dot_1*(D2^2/D1^2)
```

18-136 Wind is blowing through a turbine at a velocity of 9 m/s. The turbine blade diameter is 35 m. The air is at 95 kPa and 20°C. If the power output from the turbine is 115 kW, the efficiency of the turbine is

- (a) 29% (b) 32% (c) 35% (d) 38% (e) 42%

Answer: (a) 29%

Solution Solved by EES Software. Solutions can be verified by copying-and-pasting the following lines on a blank EES screen. (Similar problems and their solutions can be obtained easily by modifying numerical values).

```
V=9 [m/s]
D=35 [m]
P=95 [kPa]
T=(20+273) [K]
W_dot=115 [kW]
R=0.287 [kJ/kg-K]
rho=P/(R*T)
A=pi*D^2/4
W_dot_available=1/2*rho*A*V^3*Convert(W, kW)
eta_wt=W_dot/W_dot_available
```

18-137 A turbine is placed at the bottom of a 70-m-high water body. Water flows through the turbine at a rate of 15 m³/s. The power potential of the turbine is

- (a) 10.3 MW (b) 8.8 MW (c) 7.6 MW (d) 7.1 MW (e) 5.9 MW

Answer (a) 10.3 MW

Solution Solved by EES Software. Solutions can be verified by copying-and-pasting the following lines on a blank EES screen. (Similar problems and their solutions can be obtained easily by modifying numerical values).

```
H=70 [m]
V_dot=15 [m^3/s]
g=9.81 [m/s^2]
rho=1000 [kg/m^3]
W_dot_ideal=rho*g*H*V_dot*Convert(W, kW)
```

18-138 The efficiency of a hydraulic turbine-generator unit is specified to be 85 percent. If the generator efficiency is 96 percent, the turbine efficiency is

- (a) 0.816 (b) 0.850 (c) 0.862 (d) 0.885 (e) 0.960

Answer (d) 0.885

Solution Solved by EES Software. Solutions can be verified by copying-and-pasting the following lines on a blank EES screen. (Similar problems and their solutions can be obtained easily by modifying numerical values).

```
eta_turbine_gen=0.85
eta_gen=0.96
eta_turbine=eta_turbine_gen/eta_gen
```

18-139 A hydraulic turbine is used to generate power by using the water in a dam. The elevation difference between the free surfaces upstream and downstream of the dam is 120 m. The water is supplied to the turbine at a rate of 150 kg/s. If the shaft power output from the turbine is 155 kW, the efficiency of the turbine is

- (a) 0.77 (b) 0.80 (c) 0.82 (d) 0.85 (e) 0.88

Answer (e) 0.88

Solution Solved by EES Software. Solutions can be verified by copying-and-pasting the following lines on a blank EES screen. (Similar problems and their solutions can be obtained easily by modifying numerical values).

```
h=120 [m]
m_dot=150 [kg/s]
W_dot_shaft=155 [kW]
g=9.81 [m/s^2]
DELTAE_dot=m_dot*g*h*Convert(W, kW)
eta_turbine=W_dot_shaft/DELTAE_dot
```

18-140 The maximum thermal efficiency of a power plant using a geothermal source at 180°C in an environment at 25°C is

- (a) 43.1% (b) 34.2% (c) 19.5% (d) 86.1% (e) 12.7%

Answer: (b) 34.2%

Solution Solved by EES Software. Solutions can be verified by copying-and-pasting the following lines on a blank EES screen. (Similar problems and their solutions can be obtained easily by modifying numerical values).

```
T_geo=180 [C]
T0=25 [C]
eta_th_max=1-(T0+273)/(T_geo+273)
```

18-141 Geothermal liquid water is available at a site at 150°C at a rate of 10 kg/s in an environment at 20°C. The maximum amount of power that can be produced from this site is

- (a) 606 kW (b) 692 kW (c) 740 kW (d) 883 kW (e) 955 kW

Answer: (e) 955 kW

Solution Solved by EES Software. Solutions can be verified by copying-and-pasting the following lines on a blank EES screen. (Similar problems and their solutions can be obtained easily by modifying numerical values).

```
T_geo=150 [C]
x_geo=0
m_dot=10 [kg/s]
T0=20 [C]
Fluid$='Steam_iapws'
h_geo=enthalpy(Fluid$, T=T_geo, x=x_geo)
s_geo=entropy(Fluid$, T=T_geo, x=x_geo)
h0=enthalpy(Fluid$, T=T0, x=0)
s0=entropy(Fluid$, T=T0, x=0)
X_dot_geo=m_dot*(h_geo-h0-(T0+273)*(s_geo-s0))
W_dot_max=X_dot_geo
```

18-142 A binary geothermal power plant produces 5 MW power using a geothermal resource at 175°C at a rate of 110 kg/s. If the temperature of geothermal water is decreased to 90°C in the heat exchanger after giving its heat to binary fluid, the thermal efficiency of the binary cycle is

- (a) 7.5% (b) 16.3% (c) 14.4% (d) 12.5% (e) 9.7%

Answer: (d) 12.5%

Solution Solved by EES Software. Solutions can be verified by copying-and-pasting the following lines on a blank EES screen. (Similar problems and their solutions can be obtained easily by modifying numerical values).

```
W_dot=5000 [kW]
T_geo_1=175 [C]
T_geo_2=90 [C]
m_dot=110 [kg/s]
Fluid$='Steam_iapws'
h_geo_1=enthalpy(Fluid$, T=T_geo_1, x=0)
h_geo_2=enthalpy(Fluid$, T=T_geo_2, x=0)
Q_dot_in=m_dot*(h_geo_1-h_geo_2)
eta_th=W_dot/Q_dot_in
```

18-143 A certain biogas consists of 75 percent methane (CH₄) and 25 percent carbon dioxide (CO₂) by volume. If the higher heating value of methane is 55,200 kJ/kg, the higher heating value of this biogas is

- (a) 25,100 kJ/kg (b) 28,800 kJ/kg (c) 33,900 kJ/kg (d) 41,400 kJ/kg
(e) 55,200 kJ/kg

Answer: (b) 28,800 kJ/kg

Solution Solved by EES Software. Solutions can be verified by copying-and-pasting the following lines on a blank EES screen. (Similar problems and their solutions can be obtained easily by modifying numerical values).

```
y_CH4=0.75
y_CO2=0.25
HHV_CH4=55200 [kJ/kg]
MM_CH4=16 [kg/kmol]
MM_CO2=44 [kg/kmol]
"Consider 100 kmol of mixture"
N_total=100 [kmol]
N_CH4=y_CH4*N_total
N_CO2=y_CO2*N_total
m_CH4=N_CH4*MM_CH4
m_CO2=N_CO2*MM_CO2
m_total=m_CH4+m_CO2
mf_CH4=m_CH4/m_total
mf_CO2=m_CO2/m_total
HHV_biogas=mf_CH4*HHV_CH4
```

18-144 Consider 100 kg of sugar beet roots whose sugar content represents 15 percent of total mass. The sugar is converted into ethanol through the reaction $C_6H_{12}O_6 \rightarrow 2 C_2H_5OH + 2 CO_2$. The amount of ethanol produced is

- (a) 15 kg (b) 13 kg (c) 9.8 kg (d) 7.7 kg (e) 5.5 kg

Answer: (d) 7.7 kg

Solution Solved by EES Software. Solutions can be verified by copying-and-pasting the following lines on a blank EES screen. (Similar problems and their solutions can be obtained easily by modifying numerical values).

```
m_beet=100 [kg]
mf_sugar=0.15
"C6H12O6 = 2 C2H5OH + 2 CO2"
MM_C6H12O6=180 [kg/kmol]
MM_C2H5OH=46 [kg/kmol]
m_sugar=mf_sugar*m_beet
m_ethanol/m_sugar=2*MM_C2H5OH/MM_C6H12O6
m_ethanol=m_sugar*m_ethanol/m_sugar
```

1-145 – 18-151 Design and Essay Problems



