

Chapter 7

ENTROPY

Entropy and the Increase of Entropy Principle

7-1C No. The $\oint \delta Q$ represents the net heat transfer during a cycle, which could be positive.

7-2C No. A system may produce more (or less) work than it receives during a cycle. A steam power plant, for example, produces more work than it receives during a cycle, the difference being the net work output.

7-3C The entropy change will be the same for both cases since entropy is a property and it has a fixed value at a fixed state.

7-4C No. In general, that integral will have a different value for different processes. However, it will have the same value for all reversible processes.

7-5C Yes.

7-6C That integral should be performed along a reversible path to determine the entropy change.

7-7C No. An isothermal process can be irreversible. Example: A system that involves paddle-wheel work while losing an equivalent amount of heat.

7-8C The value of this integral is always larger for reversible processes.

7-9C No. Because the entropy of the surrounding air increases even more during that process, making the total entropy change positive.

7-10C It is possible to create entropy, but it is not possible to destroy it.

7-11C If the system undergoes a reversible process, the entropy of the system cannot change without a heat transfer. Otherwise, the entropy must increase since there are no offsetting entropy changes associated with reservoirs exchanging heat with the system.

7-12C The claim that work will not change the entropy of a fluid passing through an adiabatic steady-flow system with a single inlet and outlet is true only if the process is also reversible. Since no real process is reversible, there will be an entropy increase in the fluid during the adiabatic process in devices such as pumps, compressors, and turbines.

7-13C Sometimes.

7-14C Never.

7-15C Always.

7-16C Increase.

7-17C Increases.

7-18C Decreases.

7-19C Sometimes.

7-20C Yes. This will happen when the system is losing heat, and the decrease in entropy as a result of this heat loss is equal to the increase in entropy as a result of irreversibilities.

7-21C They are heat transfer, irreversibilities, and entropy transport with mass.

7-22C Greater than.

7-23 A rigid tank contains an ideal gas that is being stirred by a paddle wheel. The temperature of the gas remains constant as a result of heat transfer out. The entropy change of the gas is to be determined.

Assumptions The gas in the tank is given to be an ideal gas.

Analysis The temperature and the specific volume of the gas remain constant during this process. Therefore, the initial and the final states of the gas are the same. Then $s_2 = s_1$ since entropy is a property. Therefore,

$$\Delta S_{\text{sys}} = 0$$

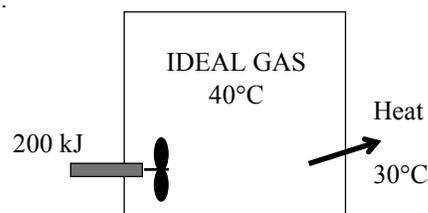

7-24 Air is compressed steadily by a compressor. The air temperature is maintained constant by heat rejection to the surroundings. The rate of entropy change of air is to be determined.

Assumptions 1 This is a steady-flow process since there is no change with time. **2** Kinetic and potential energy changes are negligible. **3** Air is an ideal gas. **4** The process involves no internal irreversibilities such as friction, and thus it is an isothermal, internally reversible process.

Properties Noting that $h = h(T)$ for ideal gases, we have $h_1 = h_2$ since $T_1 = T_2 = 25^\circ\text{C}$.

Analysis We take the compressor as the system. Noting that the enthalpy of air remains constant, the energy balance for this steady-flow system can be expressed in the rate form as

$$\underbrace{\dot{E}_{\text{in}} - \dot{E}_{\text{out}}}_{\text{Rate of net energy transfer by heat, work, and mass}} = \underbrace{\dot{\Delta E}_{\text{system}}}_{\text{Rate of change in internal, kinetic, potential, etc. energies}} \stackrel{\text{no (steady)}}{=} 0$$

$$\dot{E}_{\text{in}} = \dot{E}_{\text{out}}$$

$$\dot{W}_{\text{in}} = \dot{Q}_{\text{out}}$$

Therefore,

$$\dot{Q}_{\text{out}} = \dot{W}_{\text{in}} = 12 \text{ kW}$$

Noting that the process is assumed to be an isothermal and internally reversible process, the rate of entropy change of air is determined to be

$$\dot{\Delta S}_{\text{air}} = -\frac{\dot{Q}_{\text{out,air}}}{T_{\text{sys}}} = -\frac{12 \text{ kW}}{298 \text{ K}} = \mathbf{-0.0403 \text{ kW/K}}$$

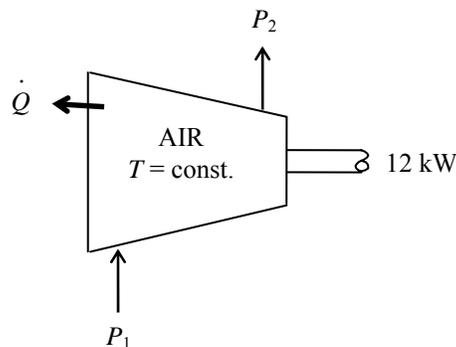

7-25 Heat is transferred directly from an energy-source reservoir to an energy-sink. The entropy change of the two reservoirs is to be calculated and it is to be determined if the increase of entropy principle is satisfied.

Assumptions The reservoirs operate steadily.

Analysis The entropy change of the source and sink is given by

$$\Delta S = \frac{Q_H}{T_H} + \frac{Q_L}{T_L} = \frac{-100 \text{ kJ}}{1200 \text{ K}} + \frac{100 \text{ kJ}}{600 \text{ K}} = \mathbf{0.0833 \text{ kJ/K}}$$

Since the entropy of everything involved in this process has increased, this transfer of heat is **possible**.

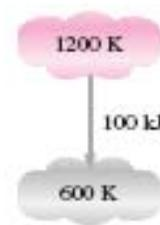

7-26 It is assumed that heat is transferred from a cold reservoir to the hot reservoir contrary to the Clausius statement of the second law. It is to be proven that this violates the increase in entropy principle.

Assumptions The reservoirs operate steadily.

Analysis According to the definition of the entropy, the entropy change of the high-temperature reservoir shown below is

$$\Delta S_H = \frac{Q}{T_H} = \frac{100 \text{ kJ}}{1200 \text{ K}} = 0.08333 \text{ kJ/K}$$

and the entropy change of the low-temperature reservoir is

$$\Delta S_L = \frac{Q}{T_L} = \frac{-100 \text{ kJ}}{600 \text{ K}} = -0.1667 \text{ kJ/K}$$

The total entropy change of everything involved with this system is then

$$\Delta S_{\text{total}} = \Delta S_H + \Delta S_L = 0.08333 - 0.1667 = \mathbf{-0.0833 \text{ kJ/K}}$$

which violates the increase in entropy principle since the entropy is decreasing, not increasing or staying fixed.

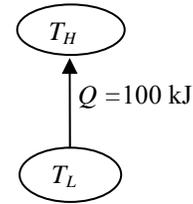

7-27 Heat is transferred from a hot reservoir to a cold reservoir. The entropy change of the two reservoirs is to be calculated and it is to be determined if the second law is satisfied.

Assumptions The reservoirs operate steadily.

Analysis The rate of entropy change of everything involved in this transfer of heat is given by

$$\Delta \dot{S} = \frac{\dot{Q}_H}{T_H} + \frac{\dot{Q}_L}{T_L} = \frac{-2 \text{ kW}}{800 \text{ K}} + \frac{2 \text{ kW}}{300 \text{ K}} = \mathbf{0.00417 \text{ kW/K}}$$

Since this rate is positive (i.e., the entropy increases as time passes), this transfer of heat is **possible**.

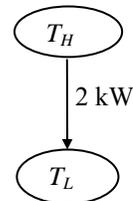

7-28E A reversible air conditioner with specified reservoir temperatures is considered. The entropy change of two reservoirs is to be calculated and it is to be determined if this air conditioner satisfies the increase in entropy principle.

Assumptions The air conditioner operates steadily.

Analysis According to the thermodynamic temperature scale,

$$\dot{Q}_H = \dot{Q}_L \frac{T_H}{T_L} = (36,000 \text{ Btu/h}) \frac{570 \text{ R}}{530 \text{ R}} = 38,720 \text{ Btu/h}$$

The rate of entropy change of the hot reservoir is then

$$\Delta\dot{S}_H = \frac{\dot{Q}_H}{T_H} = \frac{-38,720 \text{ Btu/h}}{570 \text{ R}} = -67.92 \text{ Btu/h} \cdot \text{R}$$

Similarly, the rate of entropy change of the cold reservoir is

$$\Delta\dot{S}_L = \frac{\dot{Q}_L}{T_L} = \frac{36,000 \text{ Btu/h}}{530 \text{ R}} = 67.92 \text{ Btu/h} \cdot \text{R}$$

The net rate of entropy change of everything in this system is

$$\Delta\dot{S}_{\text{total}} = \Delta\dot{S}_H + \Delta\dot{S}_L = -67.92 + 67.92 = \mathbf{0 \text{ Btu/h} \cdot \text{R}}$$

The net rate of entropy change is zero as it must be in order to satisfy the second law.

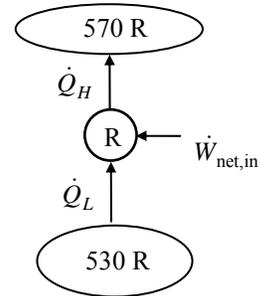

7-29 A reversible heat pump with specified reservoir temperatures is considered. The entropy change of two reservoirs is to be calculated and it is to be determined if this heat pump satisfies the increase in entropy principle.

Assumptions The heat pump operates steadily.

Analysis Since the heat pump is completely reversible, the combination of the coefficient of performance expression, first Law, and thermodynamic temperature scale gives

$$\text{COP}_{\text{HP,rev}} = \frac{1}{1 - T_L / T_H} = \frac{1}{1 - (283 \text{ K}) / (294 \text{ K})} = 26.73$$

The power required to drive this heat pump, according to the coefficient of performance, is then

$$\dot{W}_{\text{net,in}} = \frac{\dot{Q}_H}{\text{COP}_{\text{HP,rev}}} = \frac{100 \text{ kW}}{26.73} = 3.741 \text{ kW}$$

According to the first law, the rate at which heat is removed from the low-temperature energy reservoir is

$$\dot{Q}_L = \dot{Q}_H - \dot{W}_{\text{net,in}} = 100 \text{ kW} - 3.741 \text{ kW} = 96.26 \text{ kW}$$

The rate at which the entropy of the high temperature reservoir changes, according to the definition of the entropy, is

$$\Delta \dot{S}_H = \frac{\dot{Q}_H}{T_H} = \frac{100 \text{ kW}}{294 \text{ K}} = \mathbf{0.340 \text{ kW/K}}$$

and that of the low-temperature reservoir is

$$\Delta \dot{S}_L = \frac{\dot{Q}_L}{T_L} = \frac{-96.26 \text{ kW}}{283 \text{ K}} = \mathbf{-0.340 \text{ kW/K}}$$

The net rate of entropy change of everything in this system is

$$\Delta \dot{S}_{\text{total}} = \Delta \dot{S}_H + \Delta \dot{S}_L = 0.340 - 0.340 = \mathbf{0 \text{ kW/K}}$$

as it must be since the heat pump is completely reversible.

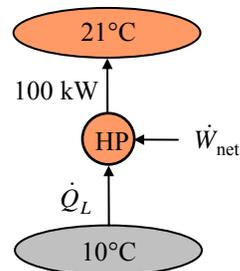

7-30E Heat is transferred isothermally from the working fluid of a Carnot engine to a heat sink. The entropy change of the working fluid is given. The amount of heat transfer, the entropy change of the sink, and the total entropy change during the process are to be determined.

Analysis (a) This is a reversible isothermal process, and the entropy change during such a process is given by

$$\Delta S = \frac{Q}{T}$$

Noting that heat transferred from the working fluid is equal to the heat transferred to the sink, the heat transfer become

$$Q_{\text{fluid}} = T_{\text{fluid}} \Delta S_{\text{fluid}} = (555 \text{ R})(-0.7 \text{ Btu/R}) = -388.5 \text{ Btu} \rightarrow Q_{\text{fluid,out}} = \mathbf{388.5 \text{ Btu}}$$

(b) The entropy change of the sink is determined from

$$\Delta S_{\text{sink}} = \frac{Q_{\text{sink,in}}}{T_{\text{sink}}} = \frac{388.5 \text{ Btu}}{555 \text{ R}} = \mathbf{0.7 \text{ Btu/R}}$$

(c) Thus the total entropy change of the process is

$$S_{\text{gen}} = \Delta S_{\text{total}} = \Delta S_{\text{fluid}} + \Delta S_{\text{sink}} = -0.7 + 0.7 = \mathbf{0}$$

This is expected since all processes of the Carnot cycle are reversible processes, and no entropy is generated during a reversible process.

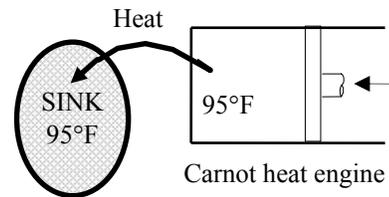

7-31 R-134a enters an evaporator as a saturated liquid-vapor at a specified pressure. Heat is transferred to the refrigerant from the cooled space, and the liquid is vaporized. The entropy change of the refrigerant, the entropy change of the cooled space, and the total entropy change for this process are to be determined.

Assumptions 1 Both the refrigerant and the cooled space involve no internal irreversibilities such as friction. **2** Any temperature change occurs within the wall of the tube, and thus both the refrigerant and the cooled space remain isothermal during this process. Thus it is an isothermal, internally reversible process.

Analysis Noting that both the refrigerant and the cooled space undergo reversible isothermal processes, the entropy change for them can be determined from

$$\Delta S = \frac{Q}{T}$$

(a) The pressure of the refrigerant is maintained constant. Therefore, the temperature of the refrigerant also remains constant at the saturation value,

$$T = T_{\text{sat}@160 \text{ kPa}} = -15.6^\circ\text{C} = 257.4 \text{ K} \quad (\text{Table A-12})$$

Then,

$$\Delta S_{\text{refrigerant}} = \frac{Q_{\text{refrigerant,in}}}{T_{\text{refrigerant}}} = \frac{180 \text{ kJ}}{257.4 \text{ K}} = \mathbf{0.699 \text{ kJ/K}}$$

(b) Similarly,

$$\Delta S_{\text{space}} = -\frac{Q_{\text{space,out}}}{T_{\text{space}}} = -\frac{180 \text{ kJ}}{268 \text{ K}} = \mathbf{-0.672 \text{ kJ/K}}$$

(c) The total entropy change of the process is

$$S_{\text{gen}} = S_{\text{total}} = \Delta S_{\text{refrigerant}} + \Delta S_{\text{space}} = 0.699 - 0.672 = \mathbf{0.027 \text{ kJ/K}}$$

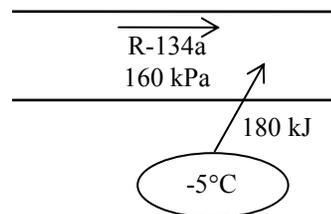

Entropy Changes of Pure Substances

7-32C Yes, because an internally reversible, adiabatic process involves no irreversibilities or heat transfer.

7-33C According to the conservation of mass principle,

$$\frac{dm_{CV}}{dt} = \sum_{in} \dot{m} - \sum_{out} \dot{m}$$

$$\frac{dm}{dt} = \dot{m}_{in}$$

An entropy balance adapted to this system becomes

$$\frac{dS_{surr}}{dt} + \frac{d(ms)}{dt} - \dot{m}_{in} s_{in} \geq 0$$

When this is combined with the mass balance, and the constant entropies are removed from the derivatives, it becomes

$$\frac{dS_{surr}}{dt} + s \frac{dm}{dt} - s_{in} \frac{dm}{dt} \geq 0$$

Multiplying by dt and integrating the result yields

$$\Delta S_{surr} + (s - s_{in}) \Delta m \geq 0$$

or

$$\Delta S_{surr} \geq (s - s_{in}) \Delta m$$

7-34C According to the conservation of mass principle,

$$\frac{dm_{CV}}{dt} = \sum_{in} \dot{m} - \sum_{out} \dot{m}$$

$$\frac{dm}{dt} = -\dot{m}_{out}$$

An entropy balance adapted to this system becomes

$$\frac{dS_{surr}}{dt} + \frac{d(ms)}{dt} + \dot{m}_{out} s \geq 0$$

When this is combined with the mass balance, it becomes

$$\frac{dS_{surr}}{dt} + s \frac{dm}{dt} - s \frac{dm}{dt} \geq 0$$

Multiplying by dt and integrating the result yields

$$\Delta S_{surr} + m_2 s_2 - m_1 s_1 - s(m_2 - m_1) \geq 0$$

Since all the entropies are same, this reduces to

$$\Delta S_{surr} \geq 0$$

Hence, the entropy of the surroundings can only increase or remain fixed.

7-35 R-134a is expanded in a turbine during which the entropy remains constant. The enthalpy difference is to be determined.

Analysis The initial state is superheated vapor and thus

$$\left. \begin{array}{l} P_1 = 250 \text{ psia} \\ T_1 = 175^\circ\text{F} \end{array} \right\} \begin{array}{l} h_1 = 129.95 \text{ Btu/lbm} \\ s_1 = 0.23281 \text{ Btu/lbm}\cdot\text{R} \end{array} \quad (\text{from EES})$$

The entropy is constant during the process. The final state is also superheated vapor and the enthalpy at this state is

$$\left. \begin{array}{l} T_2 = 20^\circ\text{F} \\ s_2 = s_1 = 0.23281 \text{ Btu/lbm}\cdot\text{R} \end{array} \right\} h_2 = 106.95 \text{ Btu/lbm} \quad (\text{from EES})$$

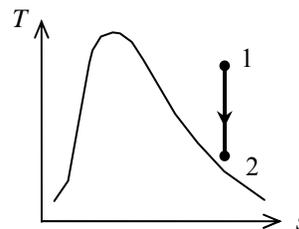

Note that the properties at the inlet and exit states can also be determined from Table A-13E by interpolation but the values will not be as accurate as those by EES. The change in the enthalpy across the turbine is then

$$\Delta h = h_2 - h_1 = 106.95 - 129.95 = -\mathbf{23.0 \text{ Btu/lbm}}$$

7-36E A piston-cylinder device that is filled with water is heated. The total entropy change is to be determined.

Analysis The initial specific volume is

$$\nu_1 = \frac{\nu_1}{m} = \frac{2.5 \text{ ft}^3}{2 \text{ lbm}} = 1.25 \text{ ft}^3/\text{lbm}$$

which is between ν_f and ν_g for 300 psia. The initial quality and the entropy are then (Table A-5E)

$$x_1 = \frac{\nu_1 - \nu_f}{\nu_{fg}} = \frac{(1.25 - 0.01890) \text{ ft}^3/\text{lbm}}{(1.5435 - 0.01890) \text{ ft}^3/\text{lbm}} = 0.8075$$

$$s_1 = s_f + x_1 s_{fg} = 0.58818 \text{ Btu/lbm}\cdot\text{R} + (0.8075)(0.92289 \text{ Btu/lbm}\cdot\text{R}) = 1.3334 \text{ Btu/lbm}\cdot\text{R}$$

The final state is superheated vapor and

$$\left. \begin{array}{l} T_2 = 500^\circ\text{F} \\ P_2 = P_1 = 300 \text{ psia} \end{array} \right\} s_2 = 1.5706 \text{ Btu/lbm}\cdot\text{R} \quad (\text{Table A - 6E})$$

Hence, the change in the total entropy is

$$\begin{aligned} \Delta S &= m(s_2 - s_1) \\ &= (2 \text{ lbm})(1.5706 - 1.3334) \text{ Btu/lbm}\cdot\text{R} \\ &= \mathbf{0.4744 \text{ Btu/R}} \end{aligned}$$

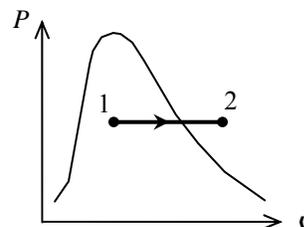
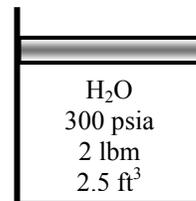

7-37 Water is compressed in a compressor during which the entropy remains constant. The final temperature and enthalpy are to be determined.

Analysis The initial state is superheated vapor and the entropy is

$$\left. \begin{array}{l} T_1 = 160^\circ\text{C} \\ P_1 = 35 \text{ kPa} \end{array} \right\} \begin{array}{l} h_1 = 2800.7 \text{ kJ/kg} \\ s_1 = 8.1531 \text{ kJ/kg}\cdot\text{K} \end{array} \quad (\text{from EES})$$

Note that the properties can also be determined from Table A-6 by interpolation but the values will not be as accurate as those by EES. The final state is superheated vapor and the properties are (Table A-6)

$$\left. \begin{array}{l} P_2 = 300 \text{ kPa} \\ s_2 = s_1 = 8.1531 \text{ kJ/kg}\cdot\text{K} \end{array} \right\} \begin{array}{l} T_2 = \mathbf{440.5^\circ\text{C}} \\ h_2 = \mathbf{3361.0 \text{ kJ/kg}} \end{array}$$

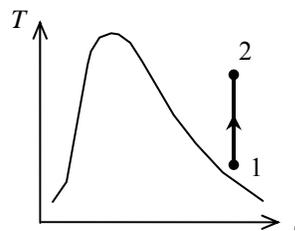

7-38E R-134a is expanded isentropically in a closed system. The heat transfer and work production are to be determined.

Assumptions 1 The system is stationary and thus the kinetic and potential energy changes are zero. **2** There are no work interactions involved other than the boundary work. **3** The thermal energy stored in the cylinder itself is negligible. **4** The compression or expansion process is quasi-equilibrium.

Analysis As there is no area under the process line shown on the T - s diagram and this process is reversible,

$$Q = \mathbf{0 \text{ Btu}}$$

The energy balance for this system can be expressed as

$$\underbrace{E_{\text{in}} - E_{\text{out}}}_{\text{Net energy transfer by heat, work, and mass}} = \underbrace{\Delta E_{\text{system}}}_{\text{Change in internal, kinetic, potential, etc. energies}}$$

$$-W_{\text{out}} = \Delta U = m(u_2 - u_1)$$

$$W_{\text{out}} = m(u_1 - u_2)$$

The initial state properties are

$$\left. \begin{array}{l} T_1 = 100^\circ\text{F} \\ P_1 = 100 \text{ psia} \end{array} \right\} \begin{array}{l} u_1 = 109.45 \text{ Btu/lbm} \\ s_1 = 0.22900 \text{ Btu/lbm}\cdot\text{R} \end{array} \quad (\text{Table A-13E})$$

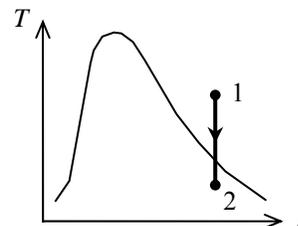
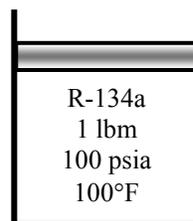

The final state properties for this isentropic process are (Table A-12E)

$$\left. \begin{array}{l} P_2 = 10 \text{ psia} \\ s_2 = s_1 = 0.22900 \text{ Btu/lbm}\cdot\text{R} \end{array} \right\} \begin{array}{l} x_2 = \frac{s_2 - s_f}{s_{fg}} = \frac{0.22900 - 0.00742}{0.22206} = 0.99784 \\ u_2 = u_f + x_2 u_{fg} = 3.135 + (0.99784)(87.453) = 90.40 \text{ Btu/lbm} \end{array}$$

Substituting,

$$W_{\text{out}} = m(u_1 - u_2) = (1 \text{ lbm})(109.45 - 90.40) \text{ Btu/lbm} = \mathbf{19.05 \text{ Btu}}$$

7-39 An insulated rigid tank contains a saturated liquid-vapor mixture of water at a specified pressure. An electric heater inside is turned on and kept on until all the liquid vaporized. The entropy change of the water during this process is to be determined.

Analysis From the steam tables (Tables A-4 through A-6)

$$\left. \begin{array}{l} P_1 = 100 \text{ kPa} \\ x_1 = 0.25 \end{array} \right\} \begin{array}{l} v_1 = v_f + x_1 v_{fg} = 0.001 + (0.25)(1.6941 - 0.001) = 0.4243 \text{ m}^3/\text{kg} \\ s_1 = s_f + x_1 s_{fg} = 1.3028 + (0.25)(6.0562) = 2.8168 \text{ kJ/kg} \cdot \text{K} \end{array}$$

$$\left. \begin{array}{l} v_2 = v_1 \\ \text{sat. vapor} \end{array} \right\} s_2 = 6.8649 \text{ kJ/kg} \cdot \text{K}$$

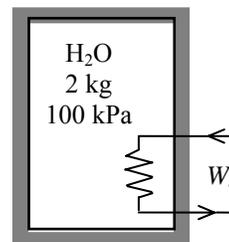

Then the entropy change of the steam becomes

$$\Delta S = m(s_2 - s_1) = (2 \text{ kg})(6.8649 - 2.8168) \text{ kJ/kg} \cdot \text{K} = \mathbf{8.10 \text{ kJ/K}}$$

7-40 [Also solved by EES on enclosed CD] A rigid tank is divided into two equal parts by a partition. One part is filled with compressed liquid water while the other side is evacuated. The partition is removed and water expands into the entire tank. The entropy change of the water during this process is to be determined.

Analysis The properties of the water are (Table A-4)

$$\left. \begin{array}{l} P_1 = 300 \text{ kPa} \\ T_1 = 60^\circ\text{C} \end{array} \right\} \begin{array}{l} v_1 \cong v_{f@60^\circ\text{C}} = 0.001017 \text{ m}^3/\text{kg} \\ s_1 = s_{f@60^\circ\text{C}} = 0.8313 \text{ kJ/kg} \cdot \text{K} \end{array}$$

Noting that

$$v_2 = 2v_1 = (2)(0.001017) = 0.002034 \text{ m}^3/\text{kg}$$

$$\left. \begin{array}{l} P_2 = 15 \text{ kPa} \\ v_2 = 0.002034 \text{ m}^3/\text{kg} \end{array} \right\} \begin{array}{l} x_2 = \frac{v_2 - v_f}{v_{fg}} = \frac{0.002034 - 0.001014}{10.02 - 0.001014} = 0.0001018 \\ s_2 = s_f + x_2 s_{fg} = 0.7549 + (0.0001018)(7.2522) = 0.7556 \text{ kJ/kg} \cdot \text{K} \end{array}$$

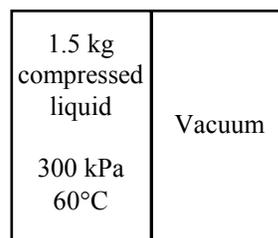

Then the entropy change of the water becomes

$$\Delta S = m(s_2 - s_1) = (1.5 \text{ kg})(0.7556 - 0.8313) \text{ kJ/kg} \cdot \text{K} = \mathbf{-0.114 \text{ kJ/K}}$$

7-41 EES Problem 7-40 is reconsidered. The entropy generated is to be evaluated and plotted as a function of surroundings temperature, and the values of the surroundings temperatures that are valid for this problem are to be determined. The surrounding temperature is to vary from 0°C to 100°C.

Analysis The problem is solved using EES, and the results are tabulated and plotted below.

"Input Data"

P[1]=300 [kPa]

T[1]=60 [C]

m=1.5 [kg]

P[2]=15 [kPa]

Fluid\$='Steam_IAPWS'

V[1]=m*spv[1]

spv[1]=volume(Fluid\$,T=T[1], P=P[1]) "specific volume of steam at state 1, m³/kg"

s[1]=entropy(Fluid\$,T=T[1],P=P[1]) "entropy of steam at state 1, kJ/kgK"

V[2]=2*V[1] "Steam expands to fill entire volume at state 2"

"State 2 is identified by P[2] and spv[2]"

spv[2]=V[2]/m "specific volume of steam at state 2, m³/kg"

s[2]=entropy(Fluid\$,P=P[2],v=spv[2]) "entropy of steam at state 2, kJ/kgK"

T[2]=temperature(Fluid\$,P=P[2],v=spv[2])

DELTAS_sys=m*(s[2]-s[1]) "Total entropy change of steam, kJ/K"

"What does the first law tell us about this problem?"

"Conservation of Energy for the entire, closed system"

E_in - E_out = DELTAE_sys

"neglecting changes in KE and PE for the system:"

DELTAE_sys=m*(intenergy(Fluid\$, P=P[2], v=spv[2]) - intenergy(Fluid\$,T=T[1],P=P[1]))

E_in = 0

"How do you interpret the energy leaving the system, E_out? Recall this is a constant volume system."

Q_out = E_out

"What is the maximum value of the Surroundings temperature?"

"The maximum possible value for the surroundings temperature occurs when we set

S_gen = 0=Delta S_sys+sum(DeltaS_surr)"

Q_net_surr=Q_out

S_gen = 0

S_gen = DELTAS_sys+Q_net_surr/Tsurr

"Establish a parametric table for the variables S_gen, Q_net_surr, T_surr, and DELTAS_sys. In the Parametric Table window select T_surr and insert a range of values. Then place '{' and '}' about the S_gen = 0 line; press F3 to solve the table. The results are shown in Plot Window 1. What values of T_surr are valid for this problem?"

S_{gen} [kJ/K]	$Q_{\text{net,surr}}$ [kJ]	T_{surr} [K]	ΔS_{sys} [kJ/K]
0.02533	37.44	270	-0.1133
0.01146	37.44	300	-0.1133
0.0001205	37.44	330	-0.1133
-0.009333	37.44	360	-0.1133
-0.01733	37.44	390	-0.1133

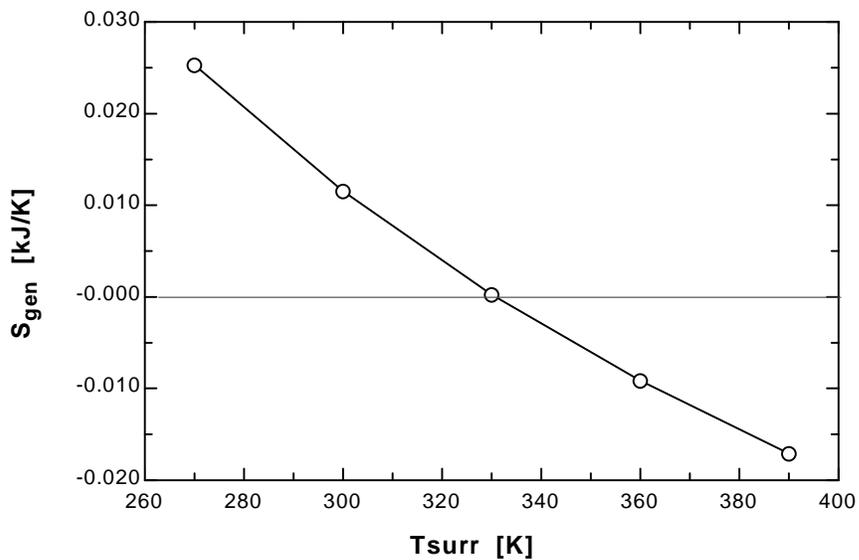

7-42E A cylinder is initially filled with R-134a at a specified state. The refrigerant is cooled and condensed at constant pressure. The entropy change of refrigerant during this process is to be determined

Analysis From the refrigerant tables (Tables A-11E through A-13E),

$$\left. \begin{array}{l} P_1 = 120 \text{ psia} \\ T_1 = 100^\circ\text{F} \end{array} \right\} s_1 = 0.22361 \text{ Btu/lbm} \cdot \text{R}$$

$$\left. \begin{array}{l} T_2 = 50^\circ\text{F} \\ P_2 = 120 \text{ psia} \end{array} \right\} s_2 \cong s_{f@90^\circ\text{F}} = 0.06039 \text{ Btu/lbm} \cdot \text{R}$$

Then the entropy change of the refrigerant becomes

$$\Delta S = m(s_2 - s_1) = (2 \text{ lbm})(0.06039 - 0.22361) \text{ Btu/lbm} \cdot \text{R} = \mathbf{-0.3264 \text{ Btu/R}}$$

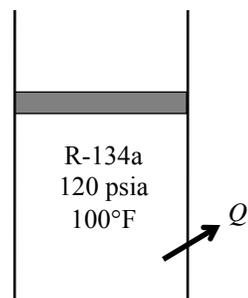

7-43 An insulated cylinder is initially filled with saturated liquid water at a specified pressure. The water is heated electrically at constant pressure. The entropy change of the water during this process is to be determined.

Assumptions **1** The kinetic and potential energy changes are negligible. **2** The cylinder is well-insulated and thus heat transfer is negligible. **3** The thermal energy stored in the cylinder itself is negligible. **4** The compression or expansion process is quasi-equilibrium.

Analysis From the steam tables (Tables A-4 through A-6),

$$P_1 = 150 \text{ kPa} \left. \begin{array}{l} \nu_1 = \nu_{f@150 \text{ kPa}} = 0.001053 \text{ m}^3/\text{kg} \\ h_1 = h_{f@150 \text{ kPa}} = 467.13 \text{ kJ/kg} \\ s_1 = s_{f@150 \text{ kPa}} = 1.4337 \text{ kJ/kg} \cdot \text{K} \end{array} \right\} \text{sat.liquid}$$

Also,

$$m = \frac{\nu}{\nu_1} = \frac{0.005 \text{ m}^3}{0.001053 \text{ m}^3/\text{kg}} = 4.75 \text{ kg}$$

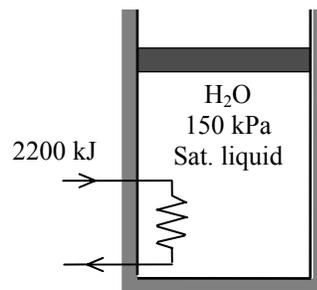

We take the contents of the cylinder as the system. This is a closed system since no mass enters or leaves. The energy balance for this stationary closed system can be expressed as

$$\underbrace{E_{\text{in}} - E_{\text{out}}}_{\text{Net energy transfer by heat, work, and mass}} = \underbrace{\Delta E_{\text{system}}}_{\text{Change in internal, kinetic, potential, etc. energies}}$$

$$W_{e,\text{in}} - W_{b,\text{out}} = \Delta U$$

$$W_{e,\text{in}} = m(h_2 - h_1)$$

since $\Delta U + W_b = \Delta H$ during a constant pressure quasi-equilibrium process. Solving for h_2 ,

$$h_2 = h_1 + \frac{W_{e,\text{in}}}{m} = 467.13 + \frac{2200 \text{ kJ}}{4.75 \text{ kg}} = 930.33 \text{ kJ/kg}$$

Thus,

$$\left. \begin{array}{l} P_2 = 150 \text{ kPa} \\ h_2 = 930.33 \text{ kJ/kg} \end{array} \right\} \begin{array}{l} x_2 = \frac{h_2 - h_f}{h_{fg}} = \frac{930.33 - 467.13}{2226.0} = 0.2081 \\ s_2 = s_f + x_2 s_{fg} = 1.4337 + (0.2081)(5.7894) = 2.6384 \text{ kJ/kg} \cdot \text{K} \end{array}$$

Then the entropy change of the water becomes

$$\Delta S = m(s_2 - s_1) = (4.75 \text{ kg})(2.6384 - 1.4337) \text{ kJ/kg} \cdot \text{K} = \mathbf{5.72 \text{ kJ/K}}$$

7-44 An insulated cylinder is initially filled with saturated R-134a vapor at a specified pressure. The refrigerant expands in a reversible manner until the pressure drops to a specified value. The final temperature in the cylinder and the work done by the refrigerant are to be determined.

Assumptions **1** The kinetic and potential energy changes are negligible. **2** The cylinder is well-insulated and thus heat transfer is negligible. **3** The thermal energy stored in the cylinder itself is negligible. **4** The process is stated to be reversible.

Analysis (a) This is a reversible adiabatic (i.e., isentropic) process, and thus $s_2 = s_1$. From the refrigerant tables (Tables A-11 through A-13),

$$P_1 = 0.8 \text{ MPa} \left. \begin{array}{l} \nu_1 = \nu_{g@0.8 \text{ MPa}} = 0.025621 \text{ m}^3/\text{kg} \\ u_1 = u_{g@0.8 \text{ MPa}} = 246.79 \text{ kJ/kg} \\ s_1 = s_{g@0.8 \text{ MPa}} = 0.91835 \text{ kJ/kg} \cdot \text{K} \end{array} \right\} \text{ sat. vapor}$$

Also,

$$m = \frac{\nu}{\nu_1} = \frac{0.05 \text{ m}^3}{0.025621 \text{ m}^3/\text{kg}} = 1.952 \text{ kg}$$

and

$$P_2 = 0.4 \text{ MPa} \left. \begin{array}{l} x_2 = \frac{s_2 - s_f}{s_{fg}} = \frac{0.91835 - 0.24761}{0.67929} = 0.9874 \\ u_2 = u_f + x_2 u_{fg} = 63.62 + (0.9874)(171.45) = 232.91 \text{ kJ/kg} \end{array} \right\} s_2 = s_1$$

$$T_2 = T_{\text{sat}@0.4 \text{ MPa}} = \mathbf{8.91^\circ\text{C}}$$

(b) We take the contents of the cylinder as the system. This is a closed system since no mass enters or leaves. The energy balance for this adiabatic closed system can be expressed as

$$\underbrace{E_{\text{in}} - E_{\text{out}}}_{\substack{\text{Net energy transfer} \\ \text{by heat, work, and mass}}} = \underbrace{\Delta E_{\text{system}}}_{\substack{\text{Change in internal, kinetic,} \\ \text{potential, etc. energies}}}$$

$$-W_{\text{b,out}} = \Delta U$$

$$W_{\text{b,out}} = m(u_1 - u_2)$$

Substituting, the work done during this isentropic process is determined to be

$$W_{\text{b,out}} = m(u_1 - u_2) = (1.952 \text{ kg})(246.79 - 232.91) \text{ kJ/kg} = \mathbf{27.09 \text{ kJ}}$$

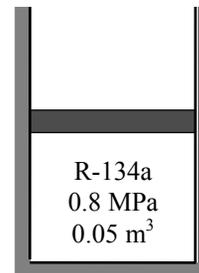

7-45 EES Problem 7-44 is reconsidered. The work done by the refrigerant is to be calculated and plotted as a function of final pressure as the pressure varies from 0.8 MPa to 0.4 MPa. The work done for this process is to be compared to one for which the temperature is constant over the same pressure range.

Analysis The problem is solved using EES, and the results are tabulated and plotted below.

Procedure

IsothermWork(P_1,x_1,m_sys,P_2:Work_out_Isotherm,Q_isotherm,DELTAE_isotherm,T_isotherm)

T_isotherm=Temperature(R134a,P=P_1,x=x_1)

T=T_isotherm

u_1 = INTENERGY(R134a,P=P_1,x=x_1)

v_1 = volume(R134a,P=P_1,x=x_1)

s_1 = entropy(R134a,P=P_1,x=x_1)

u_2 = INTENERGY(R134a,P=P_2,T=T)

s_2 = entropy(R134a,P=P_2,T=T)

"The process is reversible and Isothermal thus the heat transfer is determined by:"

Q_isotherm = (T+273)*m_sys*(s_2 - s_1)

DELTAE_isotherm = m_sys*(u_2 - u_1)

E_in = Q_isotherm

E_out = DELTAE_isotherm+E_in

Work_out_isotherm=E_out

END

"Knowns:"

P_1 = 800 [kPa]

x_1 = 1.0

V_sys = 0.05[m^3]

"P_2 = 400 [kPa]"

"Analysis: "

" Treat the rigid tank as a closed system, with no heat transfer in, neglect changes in KE and PE of the R134a."

"The isentropic work is determined from:"

E_in - E_out = DELTAE_sys

E_out = Work_out_isen

E_in = 0

DELTAE_sys = m_sys*(u_2 - u_1)

u_1 = INTENERGY(R134a,P=P_1,x=x_1)

v_1 = volume(R134a,P=P_1,x=x_1)

s_1 = entropy(R134a,P=P_1,x=x_1)

V_sys = m_sys*v_1

"Rigid Tank: The process is reversible and adiabatic or isentropic.

Then P_2 and s_2 specify state 2."

s_2 = s_1

u_2 = INTENERGY(R134a,P=P_2,s=s_2)

T_2_isen = temperature(R134a,P=P_2,s=s_2)

Call

IsothermWork(P_1,x_1,m_sys,P_2:Work_out_Isotherm,Q_isotherm,DELTAE_isotherm,T_isotherm)

P_2 [kPa]	$Work_{out,isen}$ [kJ]	$Work_{out,isotherm}$ [kJ]	$Q_{isotherm}$ [kJ]
400	27.09	60.02	47.08
500	18.55	43.33	33.29
600	11.44	28.2	21.25
700	5.347	13.93	10.3
800	0	0	0

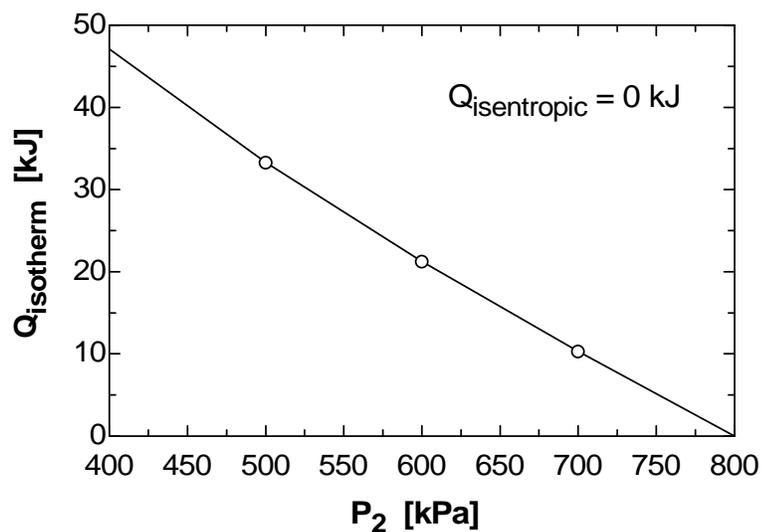
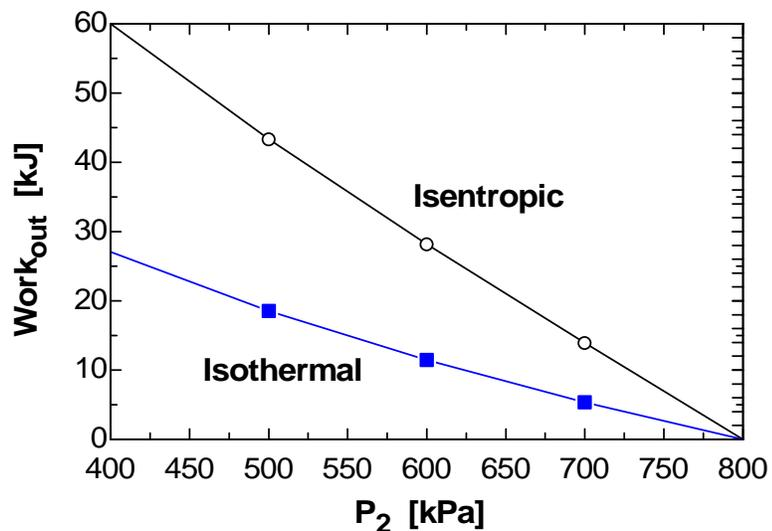

7-46 Saturated Refrigerant-134a vapor at 160 kPa is compressed steadily by an adiabatic compressor. The minimum power input to the compressor is to be determined.

Assumptions 1 This is a steady-flow process since there is no change with time. **2** Kinetic and potential energy changes are negligible. **3** The device is adiabatic and thus heat transfer is negligible.

Analysis The power input to an adiabatic compressor will be a minimum when the compression process is reversible. For the reversible adiabatic process we have $s_2 = s_1$. From the refrigerant tables (Tables A-11 through A-13),

$$P_1 = 160 \text{ kPa} \left. \begin{array}{l} \nu_1 = \nu_{g@160 \text{ kPa}} = 0.12348 \text{ m}^3/\text{kg} \\ h_1 = h_{g@160 \text{ kPa}} = 241.11 \text{ kJ/kg} \\ s_1 = s_{g@160 \text{ kPa}} = 0.9419 \text{ kJ/kg} \cdot \text{K} \end{array} \right\} \text{ sat. vapor}$$

$$P_2 = 900 \text{ kPa} \left. \begin{array}{l} h_2 = 277.06 \text{ kJ/kg} \\ s_2 = s_1 \end{array} \right\}$$

Also,

$$\dot{m} = \frac{\dot{V}_1}{\nu_1} = \frac{2 \text{ m}^3/\text{min}}{0.12348 \text{ m}^3/\text{kg}} = 16.20 \text{ kg/min} = 0.27 \text{ kg/s}$$

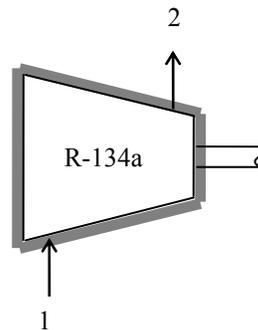

There is only one inlet and one exit, and thus $\dot{m}_1 = \dot{m}_2 = \dot{m}$. We take the compressor as the system, which is a control volume since mass crosses the boundary. The energy balance for this steady-flow system can be expressed in the rate form as

$$\underbrace{\dot{E}_{\text{in}} - \dot{E}_{\text{out}}}_{\text{Rate of net energy transfer by heat, work, and mass}} = \underbrace{\Delta \dot{E}_{\text{system}}}_{\text{Rate of change in internal, kinetic, potential, etc. energies}} \stackrel{\approx 0 \text{ (steady)}}{=} 0$$

$$\dot{E}_{\text{in}} = \dot{E}_{\text{out}}$$

$$\dot{W}_{\text{in}} + \dot{m}h_1 = \dot{m}h_2 \quad (\text{since } \dot{Q} \cong \Delta ke \cong \Delta pe \cong 0)$$

$$\dot{W}_{\text{in}} = \dot{m}(h_2 - h_1)$$

Substituting, the minimum power supplied to the compressor is determined to be

$$\dot{W}_{\text{in}} = (0.27 \text{ kg/s})(277.06 - 241.11) \text{ kJ/kg} = \mathbf{9.71 \text{ kW}}$$

7-47 An insulated cylinder is initially filled with superheated steam at a specified state. The steam is compressed in a reversible manner until the pressure drops to a specified value. The work input during this process is to be determined.

Assumptions **1** The kinetic and potential energy changes are negligible. **2** The cylinder is well-insulated and thus heat transfer is negligible. **3** The thermal energy stored in the cylinder itself is negligible. **4** The process is stated to be reversible.

Analysis This is a reversible adiabatic (i.e., isentropic) process, and thus $s_2 = s_1$. From the steam tables (Tables A-4 through A-6),

$$\left. \begin{array}{l} P_1 = 300 \text{ kPa} \\ T_1 = 150^\circ\text{C} \end{array} \right\} \begin{array}{l} v_1 = 0.63402 \text{ m}^3/\text{kg} \\ u_1 = 2571.0 \text{ kJ/kg} \\ s_1 = 7.0792 \text{ kJ/kg}\cdot\text{K} \end{array}$$

$$\left. \begin{array}{l} P_2 = 1 \text{ MPa} \\ s_2 = s_1 \end{array} \right\} u_2 = 2773.8 \text{ kJ/kg}$$

Also,

$$m = \frac{V}{v_1} = \frac{0.05 \text{ m}^3}{0.63402 \text{ m}^3/\text{kg}} = 0.0789 \text{ kg}$$

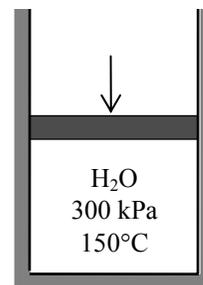

We take the contents of the cylinder as the system. This is a closed system since no mass enters or leaves. The energy balance for this adiabatic closed system can be expressed as

$$\underbrace{E_{\text{in}} - E_{\text{out}}}_{\substack{\text{Net energy transfer} \\ \text{by heat, work, and mass}}} = \underbrace{\Delta E_{\text{system}}}_{\substack{\text{Change in internal, kinetic,} \\ \text{potential, etc. energies}}}$$

$$W_{\text{b,in}} = \Delta U = m(u_2 - u_1)$$

Substituting, the work input during this adiabatic process is determined to be

$$W_{\text{b,in}} = m(u_2 - u_1) = (0.0789 \text{ kg})(2773.8 - 2571.0) \text{ kJ/kg} = \mathbf{16.0 \text{ kJ}}$$

7-48 EES Problem 7-47 is reconsidered. The work done on the steam is to be determined and plotted as a function of final pressure as the pressure varies from 300 kPa to 1 MPa.

Analysis The problem is solved using EES, and the results are tabulated and plotted below.

"Knowns:"

$$P_1 = 300 \text{ [kPa]}$$

$$T_1 = 150 \text{ [C]}$$

$$V_{\text{sys}} = 0.05 \text{ [m}^3\text{]}$$

$$P_2 = 1000 \text{ [kPa]}$$

"Analysis: "

$$\text{Fluid} = \text{'Steam_IAPWS'}$$

" Treat the piston-cylinder as a closed system, with no heat transfer in, neglect changes in KE and PE of the Steam. The process is reversible and adiabatic thus isentropic."

"The isentropic work is determined from:"

$$E_{\text{in}} - E_{\text{out}} = \Delta E_{\text{sys}}$$

$$E_{\text{out}} = 0 \text{ [kJ]}$$

$$E_{\text{in}} = \text{Work}_{\text{in}}$$

$$\Delta E_{\text{sys}} = m_{\text{sys}}(u_2 - u_1)$$

$$u_1 = \text{INTENERGY}(\text{Fluid}, P=P_1, T=T_1)$$

$$v_1 = \text{volume}(\text{Fluid}, P=P_1, T=T_1)$$

$$s_1 = \text{entropy}(\text{Fluid}, P=P_1, T=T_1)$$

$$V_{\text{sys}} = m_{\text{sys}}v_1$$

" The process is reversible and adiabatic or isentropic.

Then P_2 and s_2 specify state 2."

$$s_2 = s_1$$

$$u_2 = \text{INTENERGY}(\text{Fluid}, P=P_2, s=s_2)$$

$$T_{2,\text{isen}} = \text{temperature}(\text{Fluid}, P=P_2, s=s_2)$$

P_2 [kPa]	Work_{in} [kJ]
300	0
400	3.411
500	6.224
600	8.638
700	10.76
800	12.67
900	14.4
1000	16

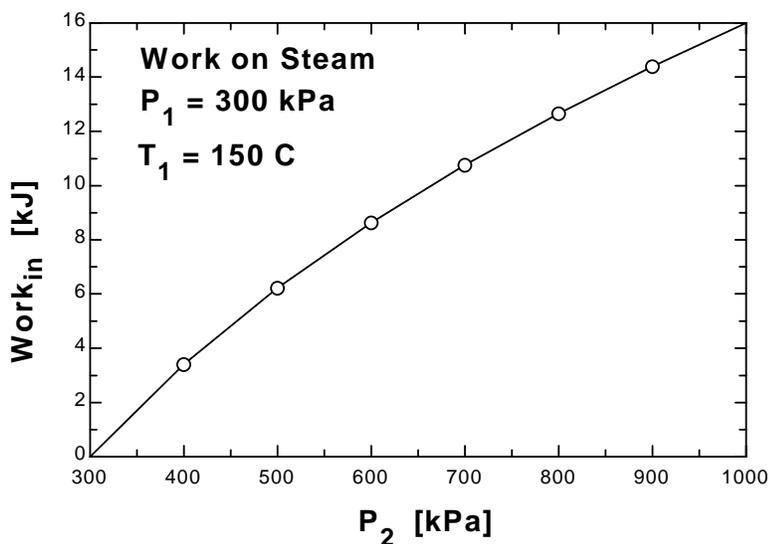

7-49 A cylinder is initially filled with saturated water vapor at a specified temperature. Heat is transferred to the steam, and it expands in a reversible and isothermal manner until the pressure drops to a specified value. The heat transfer and the work output for this process are to be determined.

Assumptions **1** The kinetic and potential energy changes are negligible. **2** The cylinder is well-insulated and thus heat transfer is negligible. **3** The thermal energy stored in the cylinder itself is negligible. **4** The process is stated to be reversible and isothermal.

Analysis From the steam tables (Tables A-4 through A-6),

$$\left. \begin{array}{l} T_1 = 200^\circ\text{C} \\ \text{sat. vapor} \end{array} \right\} \begin{array}{l} u_1 = u_{g@200^\circ\text{C}} = 2594.2 \text{ kJ/kg} \\ s_1 = s_{g@200^\circ\text{C}} = 6.4302 \text{ kJ/kg} \cdot \text{K} \end{array}$$

$$\left. \begin{array}{l} P_2 = 800 \text{ kPa} \\ T_2 = T_1 \end{array} \right\} \begin{array}{l} u_2 = 2631.1 \text{ kJ/kg} \\ s_2 = 6.8177 \text{ kJ/kg} \cdot \text{K} \end{array}$$

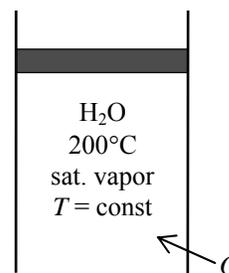

The heat transfer for this reversible isothermal process can be determined from

$$Q = T\Delta S = Tm(s_2 - s_1) = (473 \text{ K})(1.2 \text{ kg})(6.8177 - 6.4302) \text{ kJ/kg} \cdot \text{K} = \mathbf{219.9 \text{ kJ}}$$

We take the contents of the cylinder as the system. This is a closed system since no mass enters or leaves. The energy balance for this closed system can be expressed as

$$\underbrace{E_{\text{in}} - E_{\text{out}}}_{\text{Net energy transfer by heat, work, and mass}} = \underbrace{\Delta E_{\text{system}}}_{\text{Change in internal, kinetic, potential, etc. energies}}$$

$$Q_{\text{in}} - W_{\text{b,out}} = \Delta U = m(u_2 - u_1)$$

$$W_{\text{b,out}} = Q_{\text{in}} - m(u_2 - u_1)$$

Substituting, the work done during this process is determined to be

$$W_{\text{b,out}} = 219.9 \text{ kJ} - (1.2 \text{ kg})(2631.1 - 2594.2) \text{ kJ/kg} = \mathbf{175.6 \text{ kJ}}$$

7-50 EES Problem 7-49 is reconsidered. The heat transferred to the steam and the work done are to be determined and plotted as a function of final pressure as the pressure varies from the initial value to the final value of 800 kPa.

Analysis The problem is solved using EES, and the results are tabulated and plotted below.

"Knowns:"

T_1 = 200 [C]
 x_1 = 1.0
 m_sys = 1.2 [kg]
 {P_2 = 800"[kPa]"}

"Analysis: "

Fluid\$='Steam_IAPWS'

" Treat the piston-cylinder as a closed system, neglect changes in KE and PE of the Steam. The process is reversible and isothermal ."

T_2 = T_1
 E_in - E_out = DELTAE_sys
 E_in = Q_in
 E_out = Work_out
 DELTAE_sys = m_sys*(u_2 - u_1)
 P_1 = pressure(Fluid\$,T=T_1,x=1.0)
 u_1 = INTENERGY(Fluid\$,T=T_1,x=1.0)
 v_1 = volume(Fluid\$,T=T_1,x=1.0)
 s_1 = entropy(Fluid\$,T=T_1,x=1.0)
 V_sys = m_sys*v_1

" The process is reversible and isothermal.

Then P_2 and T_2 specify state 2."

u_2 = INTENERGY(Fluid\$,P=P_2,T=T_2)
 s_2 = entropy(Fluid\$,P=P_2,T=T_2)
 Q_in = (T_1+273)*m_sys*(s_2-s_1)

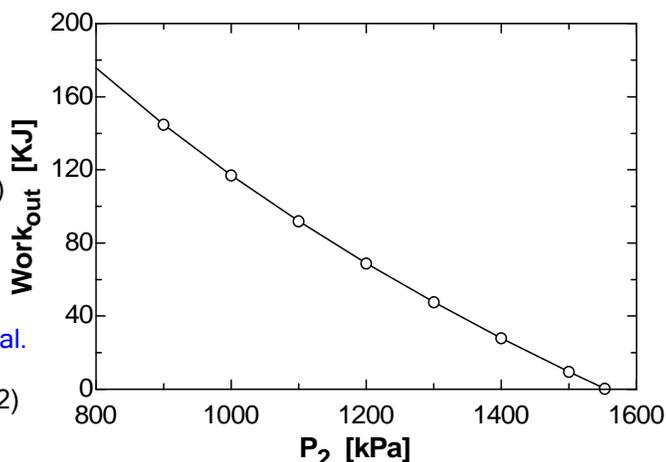

P ₂ [kPa]	Q _{in} [kJ]	Work _{out} [kJ]
800	219.9	175.7
900	183.7	144.7
1000	150.6	117
1100	120	91.84
1200	91.23	68.85
1300	64.08	47.65
1400	38.2	27.98
1500	13.32	9.605
1553	219.9	175.7

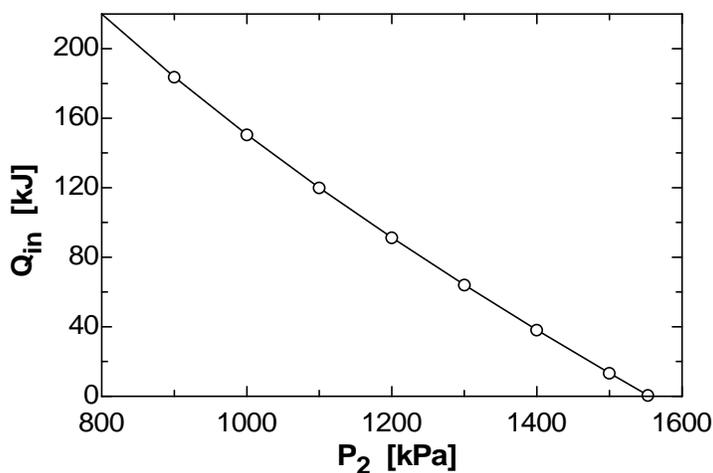

7-51 Water is compressed isentropically in a closed system. The work required is to be determined.

Assumptions 1 The system is stationary and thus the kinetic and potential energy changes are zero. **2** There are no work interactions involved other than the boundary work. **3** The thermal energy stored in the cylinder itself is negligible. **4** The compression or expansion process is quasi-equilibrium.

Analysis The energy balance for this system can be expressed as

$$\underbrace{E_{\text{in}} - E_{\text{out}}}_{\substack{\text{Net energy transfer} \\ \text{by heat, work, and mass}}} = \underbrace{\Delta E_{\text{system}}}_{\substack{\text{Change in internal, kinetic,} \\ \text{potential, etc. energies}}}$$

$$W_{\text{in}} = \Delta U = m(u_2 - u_1)$$

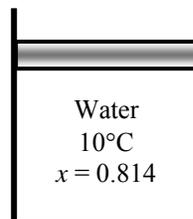

The initial state properties are

$$u_1 = u_f + x_1 u_{fg} = 42.020 + (0.814)(2346.6) = 1952.2 \text{ kJ/kg}$$

$$s_1 = s_f + x_1 s_{fg} = 0.1511 + (0.814)(8.7488) = 7.2726 \text{ kJ/kg} \cdot \text{K}$$

Since the entropy is constant during this process,

$$\left. \begin{array}{l} P_2 = 3 \text{ MPa} \\ s_2 = s_1 = 7.2726 \text{ kJ/kg} \cdot \text{K} \end{array} \right\} u_2 = 3132.6 \text{ kJ/kg} \quad (\text{Table A-6})$$

Substituting,

$$w_{\text{in}} = u_2 - u_1 = (3132.6 - 1952.2) \text{ kJ/kg} = \mathbf{1180.4 \text{ kJ/kg}}$$

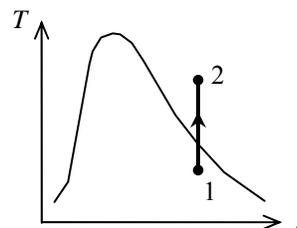

7-52 R-134a undergoes an isothermal process in a closed system. The work and heat transfer are to be determined.

Assumptions 1 The system is stationary and thus the kinetic and potential energy changes are zero. **2** There are no work interactions involved other than the boundary work. **3** The thermal energy stored in the cylinder itself is negligible. **4** The compression or expansion process is quasi-equilibrium.

Analysis The energy balance for this system can be expressed as

$$\underbrace{E_{\text{in}} - E_{\text{out}}}_{\text{Net energy transfer by heat, work, and mass}} = \underbrace{\Delta E_{\text{system}}}_{\text{Change in internal, kinetic, potential, etc. energies}}$$

$$W_{\text{in}} - Q_{\text{out}} = \Delta U = m(u_2 - u_1)$$

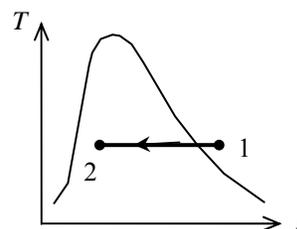
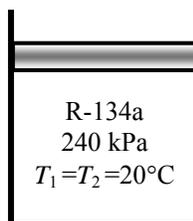

The initial state properties are

$$\left. \begin{array}{l} P_1 = 240 \text{ kPa} \\ T_1 = 20^\circ\text{C} \end{array} \right\} \begin{array}{l} u_1 = 246.74 \text{ kJ/kg} \\ s_1 = 1.0134 \text{ kJ/kg} \cdot \text{K} \end{array} \quad (\text{Table A-13})$$

For this isothermal process, the final state properties are (Table A-11)

$$\left. \begin{array}{l} T_2 = T_1 = 20^\circ\text{C} \\ x_2 = 0.20 \end{array} \right\} \begin{array}{l} u_2 = u_f + x_2 u_{fg} = 78.86 + (0.20)(162.16) = 111.29 \text{ kJ/kg} \\ s_2 = s_f + x_2 s_{fg} = 0.30063 + (0.20)(0.62172) = 0.42497 \text{ kJ/kg} \cdot \text{K} \end{array}$$

The heat transfer is determined from

$$q_{\text{in}} = T_0 (s_2 - s_1) = (293 \text{ K})(0.42497 - 1.0134) \text{ kJ/kg} \cdot \text{K} = -172.4 \text{ kJ/kg}$$

The negative sign shows that the heat is actually transferred from the system. That is,

$$q_{\text{out}} = \mathbf{172.4 \text{ kJ/kg}}$$

The work required is determined from the energy balance to be

$$w_{\text{in}} = q_{\text{out}} + (u_2 - u_1) = 172.4 \text{ kJ/kg} + (111.29 - 246.74) \text{ kJ/kg} = \mathbf{36.95 \text{ kJ/kg}}$$

7-53 The total heat transfer for the process 1-3 shown in the figure is to be determined.

Analysis For a reversible process, the area under the process line in T - s diagram is equal to the heat transfer during that process. Then,

$$\begin{aligned} Q_{1-3} &= Q_{1-2} + Q_{2-3} \\ &= \int_1^2 T dS + \int_2^3 T dS \\ &= \frac{T_1 + T_2}{2} (S_2 - S_1) + T_2 (S_3 - S_2) \\ &= \frac{(360 + 273) + (55 + 273) \text{ K}}{2} (3 - 1) \text{ kJ/K} + (360 + 273 \text{ K})(2 - 3) \text{ kJ/kg} \cdot \text{K} \\ &= \mathbf{328 \text{ kJ}} \end{aligned}$$

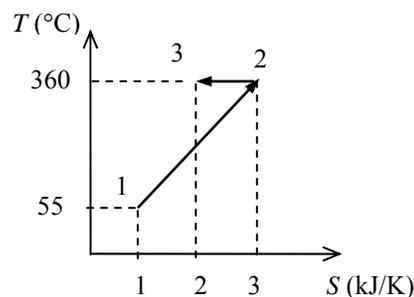

7-54 The total heat transfer for the process 1-2 shown in the figure is to be determined.

Analysis For a reversible process, the area under the process line in T - s diagram is equal to the heat transfer during that process. Then,

$$\begin{aligned} Q_{1-2} &= \int_1^2 T ds \\ &= \frac{T_1 + T_2}{2} (s_2 - s_1) \\ &= \frac{(500 + 273) + (100 + 273) \text{ K}}{2} (1.0 - 0.2) \text{ kJ/K} \\ &= \mathbf{458.4 \text{ kJ}} \end{aligned}$$

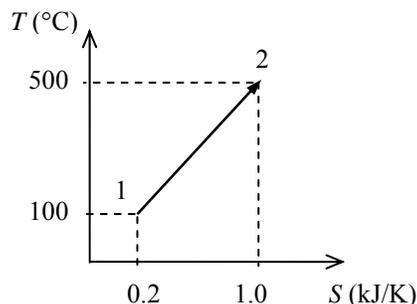

7-55 The heat transfer for the process 1-3 shown in the figure is to be determined.

Analysis For a reversible process, the area under the process line in T - s diagram is equal to the heat transfer during that process. Then,

$$\begin{aligned} q_{1-3} &= \int_1^2 T ds + \int_2^3 T ds \\ &= \frac{T_1 + T_2}{2} (s_2 - s_1) + 0 \\ &= \frac{(120 + 273) + (30 + 273) \text{ K}}{2} (1.0 - 0.02) \text{ kJ/kg} \cdot \text{K} \\ &= \mathbf{341.0 \text{ kJ/kg}} \end{aligned}$$

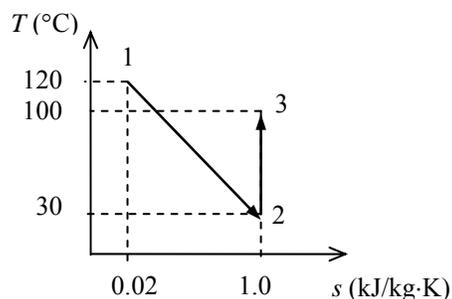

7-56E The total heat transfer for the process 1-2 shown in the figure is to be determined.

Analysis For a reversible process, the area under the process line in T - s diagram is equal to the heat transfer during that process. Then,

$$\begin{aligned} Q_{1-2} &= \int_1^2 T ds \\ &= \frac{T_1 + T_2}{2} (s_2 - s_1) \\ &= \frac{(500 + 460) + (100 + 460) \text{ R}}{2} (1.0 - 0.2) \text{ Btu/lbm} \cdot \text{R} \\ &= \mathbf{608 \text{ Btu/lbm}} \end{aligned}$$

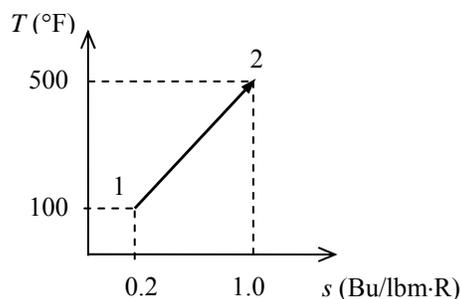

7-57 The change in the entropy of R-134a as it is heated at constant pressure is to be calculated using the relation $ds = (\delta Q / T)_{\text{int rev}}$, and it is to be verified by using R-134a tables.

Analysis As R-134a is converted from a saturated liquid to a saturated vapor, both the pressure and temperature remains constant. Then, the relation $ds = (\delta Q / T)_{\text{int rev}}$ reduces to

$$ds = \frac{dh}{T}$$

When this result is integrated between the saturated liquid and saturated vapor states, the result is (Table A-12)

$$\begin{aligned} s_g - s_f &= \frac{h_g - h_f}{T} = \frac{h_{fg @ 200 \text{ kPa}}}{T_{\text{sat @ 200 kPa}}} \\ &= \frac{206.03 \text{ kJ/kg}}{(-10.09 + 273.15) \text{ K}} = \mathbf{0.78321 \text{ kJ/kg} \cdot \text{K}} \end{aligned}$$

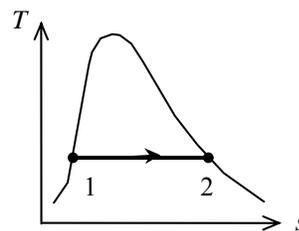

Finding the result directly from the R-134a tables

$$s_g - s_f = s_{fg @ 200 \text{ kPa}} = \mathbf{0.78316 \text{ kJ/kg} \cdot \text{K}} \quad (\text{Table A-12})$$

The two results are practically identical.

7-58 Steam is expanded in an isentropic turbine. The work produced is to be determined.

Assumptions 1 This is a steady-flow process since there is no change with time. **2** The process is isentropic (i.e., reversible-adiabatic).

Analysis There is only one inlet and one exit, and thus $\dot{m}_1 = \dot{m}_2 = \dot{m}$. We take the turbine as the system, which is a control volume since mass crosses the boundary. The energy balance for this steady-flow system can be expressed in the rate form as

$$\underbrace{\dot{E}_{\text{in}} - \dot{E}_{\text{out}}}_{\text{Rate of net energy transfer by heat, work, and mass}} = \underbrace{\Delta \dot{E}_{\text{system}}}_{\text{Rate of change in internal, kinetic, potential, etc. energies}} \stackrel{\approx 0 \text{ (steady)}}{=} 0$$

$$\dot{E}_{\text{in}} = \dot{E}_{\text{out}}$$

$$\dot{m}h_1 = \dot{m}h_2 + \dot{W}_{\text{out}}$$

$$\dot{W}_{\text{out}} = \dot{m}(h_1 - h_2)$$

The inlet state properties are

$$\left. \begin{array}{l} P_1 = 2 \text{ MPa} \\ T_1 = 360^\circ\text{C} \end{array} \right\} \begin{array}{l} h_1 = 3159.9 \text{ kJ/kg} \\ s_1 = 6.9938 \text{ kJ/kg} \cdot \text{K} \end{array} \quad (\text{Table A-6})$$

For this isentropic process, the final state properties are (Table A-5)

$$\left. \begin{array}{l} P_2 = 100 \text{ kPa} \\ s_2 = s_1 = 6.9938 \text{ kJ/kg} \cdot \text{K} \end{array} \right\} \begin{array}{l} x_2 = \frac{s_2 - s_f}{s_{fg}} = \frac{6.9938 - 1.3028}{6.0562} = 0.9397 \\ h_2 = h_f + x_2 h_{fg} = 417.51 + (0.9397)(2257.5) = 2538.9 \text{ kJ/kg} \end{array}$$

Substituting,

$$w_{\text{out}} = h_1 - h_2 = (3159.9 - 2538.9) \text{ kJ/kg} = \mathbf{621.0 \text{ kJ/kg}}$$

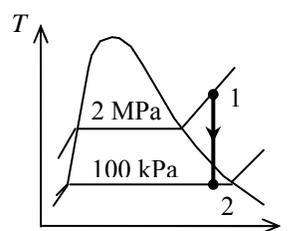
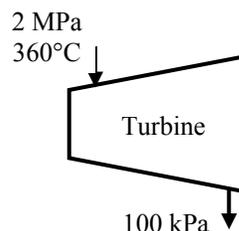

7-59 R-134a is compressed in an isentropic compressor. The work required is to be determined.

Assumptions 1 This is a steady-flow process since there is no change with time. **2** The process is isentropic (i.e., reversible-adiabatic).

Analysis There is only one inlet and one exit, and thus $\dot{m}_1 = \dot{m}_2 = \dot{m}$. We take the compressor as the system, which is a control volume since mass crosses the boundary. The energy balance for this steady-flow system can be expressed in the rate form as

$$\underbrace{\dot{E}_{\text{in}} - \dot{E}_{\text{out}}}_{\text{Rate of net energy transfer by heat, work, and mass}} = \underbrace{\Delta \dot{E}_{\text{system}}}_{\text{Rate of change in internal, kinetic, potential, etc. energies}} \stackrel{\text{no (steady)}}{=} 0$$

$$\dot{E}_{\text{in}} = \dot{E}_{\text{out}}$$

$$\dot{m}h_1 + \dot{W}_{\text{in}} = \dot{m}h_2$$

$$\dot{W}_{\text{in}} = \dot{m}(h_2 - h_1)$$

The inlet state properties are

$$\left. \begin{array}{l} T_1 = 0^\circ\text{F} \\ x_1 = 1 \end{array} \right\} \begin{array}{l} h_1 = 103.08 \text{ Btu/lbm} \\ s_1 = 0.22539 \text{ Btu/lbm} \cdot \text{R} \end{array} \quad (\text{Table A - 11E})$$

For this isentropic process, the final state enthalpy is

$$\left. \begin{array}{l} P_2 = 200 \text{ psia} \\ s_2 = s_1 = 0.22539 \text{ Btu/lbm} \cdot \text{R} \end{array} \right\} h_2 = 123.28 \text{ Btu/lbm} \quad (\text{Table A - 13E})$$

Substituting,

$$w_{\text{in}} = h_2 - h_1 = (123.28 - 103.08) \text{ Btu/lbm} = \mathbf{20.2 \text{ Btu/lbm}}$$

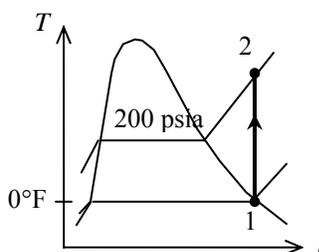
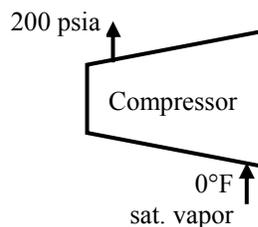

7-60 Steam is expanded in an isentropic turbine. The work produced is to be determined.

Assumptions 1 This is a steady-flow process since there is no change with time. **2** The process is isentropic (i.e., reversible-adiabatic).

Analysis There is one inlet and two exits. We take the turbine as the system, which is a control volume since mass crosses the boundary. The energy balance for this steady-flow system can be expressed in the rate form as

$$\underbrace{\dot{E}_{\text{in}} - \dot{E}_{\text{out}}}_{\text{Rate of net energy transfer by heat, work, and mass}} = \underbrace{\Delta \dot{E}_{\text{system}}}_{\text{Rate of change in internal, kinetic, potential, etc. energies}} \stackrel{\text{no (steady)}}{=} 0$$

$$\dot{E}_{\text{in}} = \dot{E}_{\text{out}}$$

$$\dot{m}_1 h_1 = \dot{m}_2 h_2 + \dot{m}_3 h_3 + \dot{W}_{\text{out}}$$

$$\dot{W}_{\text{out}} = \dot{m}_1 h_1 - \dot{m}_2 h_2 - \dot{m}_3 h_3$$

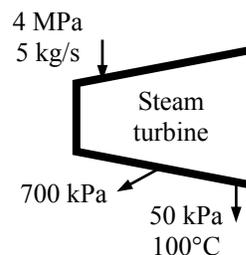

From a mass balance,

$$\dot{m}_2 = 0.05 \dot{m}_1 = (0.05)(5 \text{ kg/s}) = 0.25 \text{ kg/s}$$

$$\dot{m}_3 = 0.95 \dot{m}_1 = (0.95)(5 \text{ kg/s}) = 4.75 \text{ kg/s}$$

Noting that the expansion process is isentropic, the enthalpies at three states are determined as follows:

$$\left. \begin{array}{l} P_3 = 50 \text{ kPa} \\ T_3 = 100^\circ\text{C} \end{array} \right\} \begin{array}{l} h_3 = 2682.4 \text{ kJ/kg} \\ s_3 = 7.6953 \text{ kJ/kg} \cdot \text{K} \end{array} \quad (\text{Table A - 6})$$

$$\left. \begin{array}{l} P_1 = 4 \text{ MPa} \\ s_1 = s_3 = 7.6953 \text{ kJ/kg} \cdot \text{K} \end{array} \right\} h_1 = 3979.3 \text{ kJ/kg} \quad (\text{Table A - 6})$$

$$\left. \begin{array}{l} P_2 = 700 \text{ kPa} \\ s_2 = s_3 = 7.6953 \text{ kJ/kg} \cdot \text{K} \end{array} \right\} h_2 = 3309.1 \text{ kJ/kg} \quad (\text{Table A - 6})$$

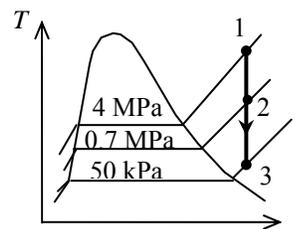

Substituting,

$$\begin{aligned} \dot{W}_{\text{out}} &= \dot{m}_1 h_1 - \dot{m}_2 h_2 - \dot{m}_3 h_3 \\ &= (5 \text{ kg/s})(3979.3 \text{ kJ/kg}) - (0.25 \text{ kg/s})(3309.1 \text{ kJ/kg}) - (4.75 \text{ kg/s})(2682.4 \text{ kJ/kg}) \\ &= \mathbf{6328 \text{ kW}} \end{aligned}$$

7-61 Heat is added to a pressure cooker that is maintained at a specified pressure. The minimum entropy change of the thermal-energy reservoir supplying this heat is to be determined.

Assumptions 1 Only water vapor escapes through the pressure relief valve.

Analysis According to the conservation of mass principle,

$$\frac{dm_{CV}}{dt} = \sum_{in} \dot{m} - \sum_{out} \dot{m}$$

$$\frac{dm}{dt} = -\dot{m}_{out}$$

An entropy balance adapted to this system becomes

$$\frac{dS_{surr}}{dt} + \frac{d(ms)}{dt} + \dot{m}_{out} s \geq 0$$

When this is combined with the mass balance, it becomes

$$\frac{dS_{surr}}{dt} + \frac{d(ms)}{dt} - s \frac{dm}{dt} \geq 0$$

Multiplying by dt and integrating the result yields

$$\Delta S_{surr} + m_2 s_2 - m_1 s_1 - s_{out} (m_2 - m_1) \geq 0$$

The properties at the initial and final states are (from Table A-5 at 200 kPa)

$$\nu_1 = \nu_f + x\nu_{fg} = 0.001061 + (0.10)(0.88578 - 0.001061) = 0.08953 \text{ m}^3/\text{kg}$$

$$s_1 = s_f + xs_{fg} = 1.5302 + (0.10)(5.5968) = 2.0899 \text{ kJ/kg} \cdot \text{K}$$

$$\nu_2 = \nu_f + x\nu_{fg} = 0.001061 + (0.50)(0.88578 - 0.001061) = 0.4434 \text{ m}^3/\text{kg}$$

$$s_2 = s_f + xs_{fg} = 1.5302 + (0.50)(5.5968) = 4.3286 \text{ kJ/kg} \cdot \text{K}$$

The initial and final masses are

$$m_1 = \frac{\nu}{\nu_1} = \frac{\nu}{\nu_f + x\nu_{fg}} = \frac{0.1 \text{ m}^3}{0.08953 \text{ m}^3/\text{kg}} = 1.117 \text{ kg}$$

$$m_2 = \frac{\nu}{\nu_2} = \frac{\nu}{\nu_f + x\nu_{fg}} = \frac{0.1 \text{ m}^3}{0.4434 \text{ m}^3/\text{kg}} = 0.2255 \text{ kg}$$

The entropy of escaping water vapor is

$$s_{out} = s_g @ 200 \text{ kPa} = 7.1270 \text{ kJ/kg} \cdot \text{K}$$

Substituting,

$$\Delta S_{surr} + m_2 s_2 - m_1 s_1 - s_{out} (m_2 - m_1) \geq 0$$

$$\Delta S_{surr} + (0.2255)(4.3286) - (1.117)(2.0899) - (7.1270)(0.2255 - 1.117) \geq 0$$

$$\Delta S_{surr} + 4.995 \geq 0$$

The entropy change of the thermal energy reservoir must then satisfy

$$\Delta S_{surr} \geq \mathbf{-4.995 \text{ kJ/K}}$$

7-62 Heat is added to a pressure cooker that is maintained at a specified pressure. Work is also done on water. The minimum entropy change of the thermal-energy reservoir supplying this heat is to be determined.

Assumptions 1 Only water vapor escapes through the pressure relief valve.

Analysis According to the conservation of mass principle,

$$\frac{dm_{CV}}{dt} = \sum_{in} \dot{m} - \sum_{out} \dot{m}$$

$$\frac{dm}{dt} = -\dot{m}_{out}$$

An entropy balance adapted to this system becomes

$$\frac{dS_{surr}}{dt} + \frac{d(ms)}{dt} + \dot{m}_{out} s \geq 0$$

When this is combined with the mass balance, it becomes

$$\frac{dS_{surr}}{dt} + \frac{d(ms)}{dt} - s \frac{dm}{dt} \geq 0$$

Multiplying by dt and integrating the result yields

$$\Delta S_{surr} + m_2 s_2 - m_1 s_1 - s_{out} (m_2 - m_1) \geq 0$$

The properties at the initial and final states are (from Table A-5 at 200 kPa)

$$\nu_1 = \nu_f + x\nu_{fg} = 0.001061 + (0.10)(0.88578 - 0.001061) = 0.08953 \text{ m}^3/\text{kg}$$

$$s_1 = s_f + xs_{fg} = 1.5302 + (0.10)(5.5968) = 2.0899 \text{ kJ/kg} \cdot \text{K}$$

$$\nu_2 = \nu_f + x\nu_{fg} = 0.001061 + (0.50)(0.88578 - 0.001061) = 0.4434 \text{ m}^3/\text{kg}$$

$$s_2 = s_f + xs_{fg} = 1.5302 + (0.50)(5.5968) = 4.3286 \text{ kJ/kg} \cdot \text{K}$$

The initial and final masses are

$$m_1 = \frac{\nu}{\nu_1} = \frac{\nu}{\nu_f + x\nu_{fg}} = \frac{0.1 \text{ m}^3}{0.08953 \text{ m}^3/\text{kg}} = 1.117 \text{ kg}$$

$$m_2 = \frac{\nu}{\nu_2} = \frac{\nu}{\nu_f + x\nu_{fg}} = \frac{0.1 \text{ m}^3}{0.4434 \text{ m}^3/\text{kg}} = 0.2255 \text{ kg}$$

The entropy of escaping water vapor is

$$s_{out} = s_g @ 200 \text{ kPa} = 7.1270 \text{ kJ/kg} \cdot \text{K}$$

Substituting,

$$\Delta S_{surr} + m_2 s_2 - m_1 s_1 - s_{out} (m_2 - m_1) \geq 0$$

$$\Delta S_{surr} + (0.2255)(4.3286) - (1.117)(2.0899) - (7.1270)(0.2255 - 1.117) \geq 0$$

$$\Delta S_{surr} + 4.995 \geq 0$$

The entropy change of the thermal energy reservoir must then satisfy

$$\Delta S_{surr} \geq -4.995 \text{ kJ/K}$$

7-63 A cylinder is initially filled with saturated water vapor mixture at a specified temperature. Steam undergoes a reversible heat addition and an isentropic process. The processes are to be sketched and heat transfer for the first process and work done during the second process are to be determined.

Assumptions 1 The kinetic and potential energy changes are negligible. 2 The thermal energy stored in the cylinder itself is negligible. 3 Both processes are reversible.

Analysis (b) From the steam tables (Tables A-4 through A-6),

$$T_1 = 100^\circ\text{C} \left. \begin{array}{l} \\ x = 0.5 \end{array} \right\} h_1 = h_f + xh_{fg} = 419.17 + (0.5)(2256.4) = 1547.4 \text{ kJ/kg}$$

$$T_2 = 100^\circ\text{C} \left. \begin{array}{l} h_2 = h_g = 2675.6 \text{ kJ/kg} \\ u_2 = u_g = 2506.0 \text{ kJ/kg} \\ s_2 = 7.3542 \text{ kJ/kg}\cdot\text{K} \end{array} \right\}$$

$$P_3 = 15 \text{ kPa} \left. \begin{array}{l} \\ s_3 = s_2 \end{array} \right\} u_3 = 2247.9 \text{ kJ/kg}$$

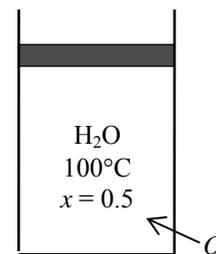

We take the contents of the cylinder as the system. This is a closed system since no mass enters or leaves. The energy balance for this closed system can be expressed as

$$\underbrace{E_{\text{in}} - E_{\text{out}}}_{\text{Net energy transfer by heat, work, and mass}} = \underbrace{\Delta E_{\text{system}}}_{\text{Change in internal, kinetic, potential, etc. energies}}$$

$$Q_{\text{in}} - W_{\text{b,out}} = \Delta U = m(u_2 - u_1)$$

For process 1-2, it reduces to

$$Q_{12,\text{in}} = m(h_2 - h_1) = (5 \text{ kg})(2675.6 - 1547.4) \text{ kJ/kg} = \mathbf{5641 \text{ kJ}}$$

(c) For process 2-3, it reduces to

$$W_{23,\text{b,out}} = m(u_2 - u_3) = (5 \text{ kg})(2506.0 - 2247.9) \text{ kJ/kg} = \mathbf{1291 \text{ kJ}}$$

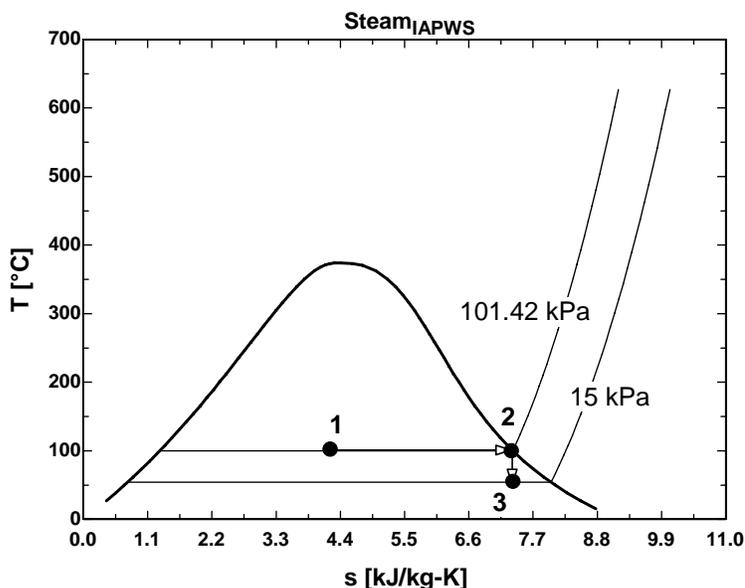

7-64 Steam expands in an adiabatic turbine. Steam leaves the turbine at two different pressures. The process is to be sketched on a T - s diagram and the work done by the steam per unit mass of the steam at the inlet are to be determined.

Assumptions 1 The kinetic and potential energy changes are negligible.

Analysis (b) From the steam tables (Tables A-4 through A-6),

$$\left. \begin{array}{l} T_1 = 500^\circ\text{C} \\ P_1 = 6 \text{ MPa} \end{array} \right\} \begin{array}{l} h_1 = 3423.1 \text{ kJ/kg} \\ s_1 = 6.8826 \text{ kJ/kg}\cdot\text{K} \end{array} \quad \left. \begin{array}{l} P_2 = 1 \text{ MPa} \\ s_2 = s_1 \end{array} \right\} h_{2s} = 2921.3 \text{ kJ/kg}$$

$$\left. \begin{array}{l} P_3 = 10 \text{ kPa} \\ s_3 = s_1 \end{array} \right\} \begin{array}{l} h_{3s} = 2179.6 \text{ kJ/kg} \\ x_{3s} = 0.831 \end{array}$$

A mass balance on the control volume gives

$$\dot{m}_1 = \dot{m}_2 + \dot{m}_3 \quad \text{where} \quad \begin{array}{l} \dot{m}_2 = 0.1\dot{m}_1 \\ \dot{m}_3 = 0.9\dot{m}_1 \end{array}$$

We take the turbine as the system, which is a control volume. The energy balance for this steady-flow system can be expressed in the rate form as

$$\begin{aligned} \dot{E}_{\text{in}} &= \dot{E}_{\text{out}} \\ \dot{m}_1 h_1 &= \dot{W}_{s,\text{out}} + \dot{m}_2 h_2 + \dot{m}_3 h_3 \\ \dot{m}_1 h_1 &= \dot{W}_{s,\text{out}} + 0.1\dot{m}_1 h_2 + 0.9\dot{m}_1 h_3 \end{aligned}$$

or

$$\begin{aligned} h_1 &= w_{s,\text{out}} + 0.1h_2 + 0.9h_3 \\ w_{s,\text{out}} &= h_1 - 0.1h_2 - 0.9h_3 \\ &= 3423.1 - (0.1)(2921.3) - (0.9)(2179.6) = 1169.3 \text{ kJ/kg} \end{aligned}$$

The actual work output per unit mass of steam at the inlet is

$$w_{\text{out}} = \eta_T w_{s,\text{out}} = (0.85)(1169.3 \text{ kJ/kg}) = \mathbf{993.9 \text{ kJ/kg}}$$

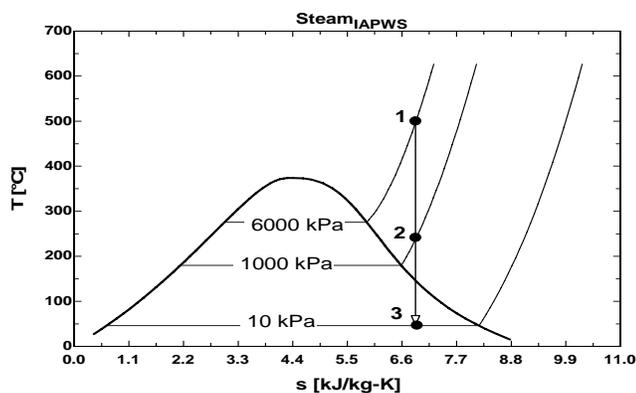
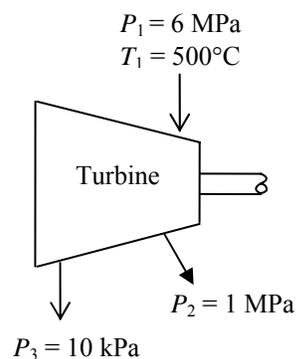

7-65E An insulated rigid can initially contains R-134a at a specified state. A crack develops, and refrigerant escapes slowly. The final mass in the can is to be determined when the pressure inside drops to a specified value.

Assumptions 1 The can is well-insulated and thus heat transfer is negligible. 2 The refrigerant that remains in the can underwent a reversible adiabatic process.

Analysis Noting that for a reversible adiabatic (i.e., isentropic) process, $s_1 = s_2$, the properties of the refrigerant in the can are (Tables A-11E through A-13E)

$$\left. \begin{array}{l} P_1 = 140 \text{ psia} \\ T_1 = 70^\circ\text{F} \end{array} \right\} s_1 \cong s_f @ 70^\circ\text{F} = 0.07306 \text{ Btu/lbm} \cdot \text{R}$$

$$\left. \begin{array}{l} P_2 = 20 \text{ psia} \\ s_2 = s_1 \end{array} \right\} \begin{array}{l} x_2 = \frac{s_2 - s_f}{s_{fg}} = \frac{0.07306 - 0.02605}{0.19962} = 0.2355 \\ \nu_2 = \nu_f + x_2 \nu_{fg} = 0.01182 + (0.2355)(2.2772 - 0.01182) = 0.5453 \text{ ft}^3/\text{lbm} \end{array}$$

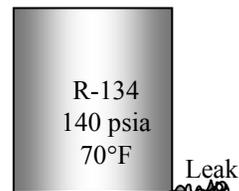

Thus the final mass of the refrigerant in the can is

$$m = \frac{\nu}{\nu_2} = \frac{1.2 \text{ ft}^3}{0.5453 \text{ ft}^3/\text{lbm}} = \mathbf{2.201 \text{ lbm}}$$

Entropy Change of Incompressible Substances

7-66C No, because entropy is not a conserved property.

7-67 A hot copper block is dropped into water in an insulated tank. The final equilibrium temperature of the tank and the total entropy change are to be determined.

Assumptions **1** Both the water and the copper block are incompressible substances with constant specific heats at room temperature. **2** The system is stationary and thus the kinetic and potential energies are negligible. **3** The tank is well-insulated and thus there is no heat transfer.

Properties The density and specific heat of water at 25°C are $\rho = 997 \text{ kg/m}^3$ and $c_p = 4.18 \text{ kJ/kg}\cdot^\circ\text{C}$. The specific heat of copper at 27°C is $c_p = 0.386 \text{ kJ/kg}\cdot^\circ\text{C}$ (Table A-3).

Analysis We take the entire contents of the tank, water + copper block, as the *system*. This is a *closed system* since no mass crosses the system boundary during the process. The energy balance for this system can be expressed as

$$\underbrace{E_{\text{in}} - E_{\text{out}}}_{\substack{\text{Net energy transfer} \\ \text{by heat, work, and mass}}} = \underbrace{\Delta E_{\text{system}}}_{\substack{\text{Change in internal, kinetic,} \\ \text{potential, etc. energies}}}$$

$$0 = \Delta U$$

or,

$$\Delta U_{\text{Cu}} + \Delta U_{\text{water}} = 0$$

$$[mc(T_2 - T_1)]_{\text{Cu}} + [mc(T_2 - T_1)]_{\text{water}} = 0$$

where

$$m_{\text{water}} = \rho V = (997 \text{ kg/m}^3)(0.120 \text{ m}^3) = 119.6 \text{ kg}$$

Using specific heat values for copper and liquid water at room temperature and substituting,

$$(50 \text{ kg})(0.386 \text{ kJ/kg}\cdot^\circ\text{C})(T_2 - 80)^\circ\text{C} + (119.6 \text{ kg})(4.18 \text{ kJ/kg}\cdot^\circ\text{C})(T_2 - 25)^\circ\text{C} = 0$$

$$T_2 = \mathbf{27.0^\circ\text{C}}$$

The entropy generated during this process is determined from

$$\Delta S_{\text{copper}} = mc_{\text{avg}} \ln\left(\frac{T_2}{T_1}\right) = (50 \text{ kg})(0.386 \text{ kJ/kg}\cdot\text{K}) \ln\left(\frac{300.0 \text{ K}}{353 \text{ K}}\right) = -3.140 \text{ kJ/K}$$

$$\Delta S_{\text{water}} = mc_{\text{avg}} \ln\left(\frac{T_2}{T_1}\right) = (119.6 \text{ kg})(4.18 \text{ kJ/kg}\cdot\text{K}) \ln\left(\frac{300.0 \text{ K}}{298 \text{ K}}\right) = 3.344 \text{ kJ/K}$$

Thus,

$$\Delta S_{\text{total}} = \Delta S_{\text{copper}} + \Delta S_{\text{water}} = -3.140 + 3.344 = \mathbf{0.204 \text{ kJ/K}}$$

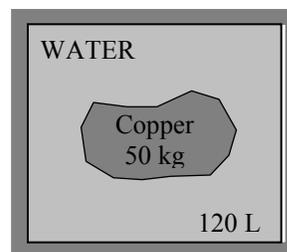

7-68 Computer chips are cooled by placing them in saturated liquid R-134a. The entropy changes of the chips, R-134a, and the entire system are to be determined.

Assumptions 1 The system is stationary and thus the kinetic and potential energy changes are zero. **2** There are no work interactions involved. **3** There is no heat transfer between the system and the surroundings.

Analysis (a) The energy balance for this system can be expressed as

$$\underbrace{E_{\text{in}} - E_{\text{out}}}_{\text{Net energy transfer by heat, work, and mass}} = \underbrace{\Delta E_{\text{system}}}_{\text{Change in internal, kinetic, potential, etc. energies}}$$

$$0 = \Delta U = [m(u_2 - u_1)]_{\text{chips}} + [m(u_2 - u_1)]_{\text{R-134a}}$$

$$[m(u_1 - u_2)]_{\text{chips}} = [m(u_2 - u_1)]_{\text{R-134a}}$$

The heat released by the chips is

$$Q_{\text{chips}} = mc(T_1 - T_2) = (0.010 \text{ kg})(0.3 \text{ kJ/kg} \cdot \text{K})[20 - (-40)] \text{ K} = 0.18 \text{ kJ}$$

The mass of the refrigerant vaporized during this heat exchange process is

$$m_{g,2} = \frac{Q_{\text{R-134a}}}{u_g - u_f} = \frac{Q_{\text{R-134a}}}{u_{fg@-40^\circ\text{C}}} = \frac{0.18 \text{ kJ}}{207.40 \text{ kJ/kg}} = 0.0008679 \text{ kg}$$

Only a small fraction of R-134a is vaporized during the process. Therefore, the temperature of R-134a remains constant during the process. The change in the entropy of the R-134a is (at -40°F from Table A-11)

$$\begin{aligned} \Delta S_{\text{R-134a}} &= m_{g,2}s_{g,2} + m_{f,2}s_{f,2} - m_{f,1}s_{f,1} \\ &= (0.0008679)(0.96866) + (0.005 - 0.0008679)(0) - (0.005)(0) \\ &= \mathbf{0.000841 \text{ kJ/K}} \end{aligned}$$

(b) The entropy change of the chips is

$$\Delta S_{\text{chips}} = mc \ln \frac{T_2}{T_1} = (0.010 \text{ kg})(0.3 \text{ kJ/kg} \cdot \text{K}) \ln \frac{(-40 + 273) \text{ K}}{(20 + 273) \text{ K}} = \mathbf{-0.000687 \text{ kJ/K}}$$

(c) The total entropy change is

$$\Delta S_{\text{total}} = S_{\text{gen}} = \Delta S_{\text{R-134a}} + \Delta S_{\text{chips}} = 0.000841 + (-0.000687) = \mathbf{0.000154 \text{ kJ/K}}$$

The positive result for the total entropy change (i.e., entropy generation) indicates that this process is possible.

7-69 A hot iron block is dropped into water in an insulated tank. The total entropy change during this process is to be determined.

Assumptions 1 Both the water and the iron block are incompressible substances with constant specific heats at room temperature. **2** The system is stationary and thus the kinetic and potential energies are negligible. **3** The tank is well-insulated and thus there is no heat transfer. **4** The water that evaporates, condenses back.

Properties The specific heat of water at 25°C is $c_p = 4.18 \text{ kJ/kg}\cdot^\circ\text{C}$. The specific heat of iron at room temperature is $c_p = 0.45 \text{ kJ/kg}\cdot^\circ\text{C}$ (Table A-3).

Analysis We take the entire contents of the tank, water + iron block, as the *system*. This is a *closed system* since no mass crosses the system boundary during the process. The energy balance for this system can be expressed as

$$\underbrace{E_{\text{in}} - E_{\text{out}}}_{\substack{\text{Net energy transfer} \\ \text{by heat, work, and mass}}} = \underbrace{\Delta E_{\text{system}}}_{\substack{\text{Change in internal, kinetic,} \\ \text{potential, etc. energies}}}$$

$$0 = \Delta U$$

or,

$$\Delta U_{\text{iron}} + \Delta U_{\text{water}} = 0$$

$$[mc(T_2 - T_1)]_{\text{iron}} + [mc(T_2 - T_1)]_{\text{water}} = 0$$

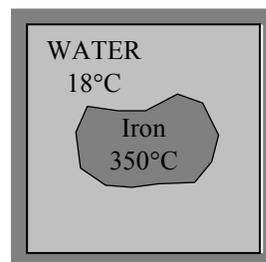

Substituting,

$$(25 \text{ kg})(0.45 \text{ kJ/kg}\cdot\text{K})(T_2 - 350^\circ\text{C}) + (100 \text{ kg})(4.18 \text{ kJ/kg}\cdot\text{K})(T_2 - 18^\circ\text{C}) = 0$$

$$T_2 = \mathbf{26.7^\circ\text{C}}$$

The entropy generated during this process is determined from

$$\Delta S_{\text{iron}} = mc_{\text{avg}} \ln\left(\frac{T_2}{T_1}\right) = (25 \text{ kg})(0.45 \text{ kJ/kg}\cdot\text{K}) \ln\left(\frac{299.7 \text{ K}}{623 \text{ K}}\right) = -8.232 \text{ kJ/K}$$

$$\Delta S_{\text{water}} = mc_{\text{avg}} \ln\left(\frac{T_2}{T_1}\right) = (100 \text{ kg})(4.18 \text{ kJ/kg}\cdot\text{K}) \ln\left(\frac{299.7 \text{ K}}{291 \text{ K}}\right) = 12.314 \text{ kJ/K}$$

Thus,

$$S_{\text{gen}} = \Delta S_{\text{total}} = \Delta S_{\text{iron}} + \Delta S_{\text{water}} = -8.232 + 12.314 = \mathbf{4.08 \text{ kJ/K}}$$

Discussion The results can be improved somewhat by using specific heats at average temperature.

7-70 An aluminum block is brought into contact with an iron block in an insulated enclosure. The final equilibrium temperature and the total entropy change for this process are to be determined.

Assumptions 1 Both the aluminum and the iron block are incompressible substances with constant specific heats. **2** The system is stationary and thus the kinetic and potential energies are negligible. **3** The system is well-insulated and thus there is no heat transfer.

Properties The specific heat of aluminum at the anticipated average temperature of 450 K is $c_p = 0.973$ kJ/kg·°C. The specific heat of iron at room temperature (the only value available in the tables) is $c_p = 0.45$ kJ/kg·°C (Table A-3).

Analysis We take the iron+aluminum blocks as the system, which is a closed system. The energy balance for this system can be expressed as

$$\underbrace{E_{\text{in}} - E_{\text{out}}}_{\substack{\text{Net energy transfer} \\ \text{by heat, work, and mass}}} = \underbrace{\Delta E_{\text{system}}}_{\substack{\text{Change in internal, kinetic,} \\ \text{potential, etc. energies}}}$$

$$0 = \Delta U$$

Iron 20 kg 100°C	Aluminum 20 kg 200°C
------------------------	----------------------------

or,

$$\Delta U_{\text{alum}} + \Delta U_{\text{iron}} = 0$$

$$[mc(T_2 - T_1)]_{\text{alum}} + [mc(T_2 - T_1)]_{\text{iron}} = 0$$

Substituting,

$$(20 \text{ kg})(0.45 \text{ kJ/kg} \cdot \text{K})(T_2 - 100^\circ \text{C}) + (20 \text{ kg})(0.973 \text{ kJ/kg} \cdot \text{K})(T_2 - 200^\circ \text{C}) = 0$$

$$T_2 = \mathbf{168.4^\circ \text{C}} = 441.4 \text{ K}$$

The total entropy change for this process is determined from

$$\Delta S_{\text{iron}} = mc_{\text{avg}} \ln \left(\frac{T_2}{T_1} \right) = (20 \text{ kg})(0.45 \text{ kJ/kg} \cdot \text{K}) \ln \left(\frac{441.4 \text{ K}}{373 \text{ K}} \right) = 1.515 \text{ kJ/K}$$

$$\Delta S_{\text{alum}} = mc_{\text{avg}} \ln \left(\frac{T_2}{T_1} \right) = (20 \text{ kg})(0.973 \text{ kJ/kg} \cdot \text{K}) \ln \left(\frac{441.4 \text{ K}}{473 \text{ K}} \right) = -1.346 \text{ kJ/K}$$

Thus,

$$\Delta S_{\text{total}} = \Delta S_{\text{iron}} + \Delta S_{\text{alum}} = 1.515 - 1.346 = \mathbf{0.169 \text{ kJ/K}}$$

7-71 EES Problem 7-70 is reconsidered. The effect of the mass of the iron block on the final equilibrium temperature and the total entropy change for the process is to be studied. The mass of the iron is to vary from 1 to 10 kg. The equilibrium temperature and the total entropy change are to be plotted as a function of iron mass.

Analysis The problem is solved using EES, and the results are tabulated and plotted below.

"Knowns:"

$$T_{1_iron} = 100 \text{ [C]}$$

$$\{m_{iron} = 20 \text{ [kg]}\}$$

$$T_{1_al} = 200 \text{ [C]}$$

$$m_{al} = 20 \text{ [kg]}$$

$$C_{al} = 0.973 \text{ [kJ/kg-K]} \text{ "From Table A-3 at the anticipated average temperature of 450 K."}$$

$$C_{iron} = 0.45 \text{ [kJ/kg-K]} \text{ "From Table A-3 at room temperature, the only value available."}$$

"Analysis: "

"Treat the iron plus aluminum as a closed system, with no heat transfer in, no work out, neglect changes in KE and PE of the system. "

"The final temperature is found from the energy balance."

$$E_{in} - E_{out} = \Delta E_{sys}$$

$$E_{out} = 0$$

$$E_{in} = 0$$

$$\Delta E_{sys} = m_{iron} \Delta U_{iron} + m_{al} \Delta U_{al}$$

$$\Delta U_{iron} = C_{iron} (T_{2_iron} - T_{1_iron})$$

$$\Delta U_{al} = C_{al} (T_{2_al} - T_{1_al})$$

"the iron and aluminum reach thermal equilibrium:"

$$T_{2_iron} = T_{2}$$

$$T_{2_al} = T_{2}$$

$$\Delta S_{iron} = m_{iron} C_{iron} \ln((T_{2_iron} + 273) / (T_{1_iron} + 273))$$

$$\Delta S_{al} = m_{al} C_{al} \ln((T_{2_al} + 273) / (T_{1_al} + 273))$$

$$\Delta S_{total} = \Delta S_{iron} + \Delta S_{al}$$

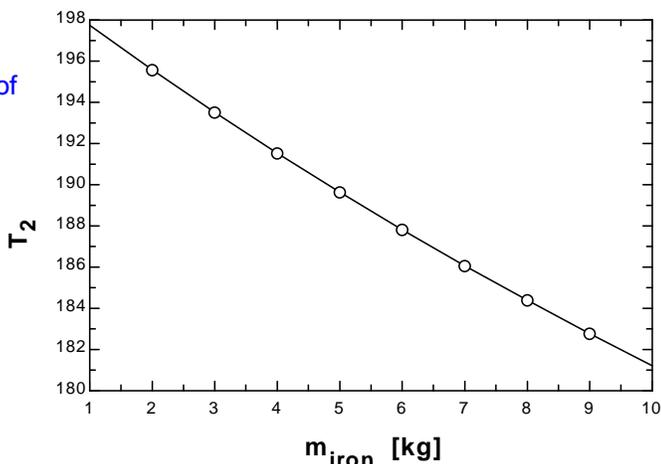

ΔS_{total} [kJ/kg]	m_{iron} [kg]	T_2 [C]
0.01152	1	197.7
0.0226	2	195.6
0.03326	3	193.5
0.04353	4	191.5
0.05344	5	189.6
0.06299	6	187.8
0.07221	7	186.1
0.08112	8	184.4
0.08973	9	182.8
0.09805	10	181.2

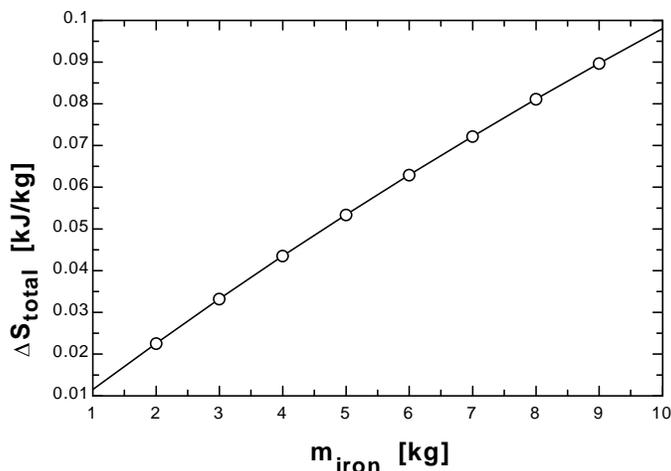

7-72 An iron block and a copper block are dropped into a large lake. The total amount of entropy change when both blocks cool to the lake temperature is to be determined.

Assumptions 1 Both the water and the iron block are incompressible substances with constant specific heats at room temperature. **2** Kinetic and potential energies are negligible.

Properties The specific heats of iron and copper at room temperature are $c_{\text{iron}} = 0.45 \text{ kJ/kg} \cdot ^\circ\text{C}$ and $c_{\text{copper}} = 0.386 \text{ kJ/kg} \cdot ^\circ\text{C}$ (Table A-3).

Analysis The thermal-energy capacity of the lake is very large, and thus the temperatures of both the iron and the copper blocks will drop to the lake temperature (15°C) when the thermal equilibrium is established. Then the entropy changes of the blocks become

$$\Delta S_{\text{iron}} = mc_{\text{avg}} \ln\left(\frac{T_2}{T_1}\right) = (50 \text{ kg})(0.45 \text{ kJ/kg} \cdot \text{K}) \ln\left(\frac{288 \text{ K}}{353 \text{ K}}\right) = -4.579 \text{ kJ/K}$$

$$\Delta S_{\text{copper}} = mc_{\text{avg}} \ln\left(\frac{T_2}{T_1}\right) = (20 \text{ kg})(0.386 \text{ kJ/kg} \cdot \text{K}) \ln\left(\frac{288 \text{ K}}{353 \text{ K}}\right) = -1.571 \text{ kJ/K}$$

We take both the iron and the copper blocks, as the *system*. This is a *closed system* since no mass crosses the system boundary during the process. The energy balance for this system can be expressed as

$$\underbrace{E_{\text{in}} - E_{\text{out}}}_{\substack{\text{Net energy transfer} \\ \text{by heat, work, and mass}}} = \underbrace{\Delta E_{\text{system}}}_{\substack{\text{Change in internal, kinetic,} \\ \text{potential, etc. energies}}}$$

$$-Q_{\text{out}} = \Delta U = \Delta U_{\text{iron}} + \Delta U_{\text{copper}}$$

or,

$$Q_{\text{out}} = [mc(T_1 - T_2)]_{\text{iron}} + [mc(T_1 - T_2)]_{\text{copper}}$$

Substituting,

$$Q_{\text{out}} = (50 \text{ kg})(0.45 \text{ kJ/kg} \cdot \text{K})(353 - 288) \text{ K} + (20 \text{ kg})(0.386 \text{ kJ/kg} \cdot \text{K})(353 - 288) \text{ K}$$

$$= 1964 \text{ kJ}$$

Thus,

$$\Delta S_{\text{lake}} = \frac{Q_{\text{lake, in}}}{T_{\text{lake}}} = \frac{1964 \text{ kJ}}{288 \text{ K}} = 6.820 \text{ kJ/K}$$

Then the total entropy change for this process is

$$\Delta S_{\text{total}} = \Delta S_{\text{iron}} + \Delta S_{\text{copper}} + \Delta S_{\text{lake}} = -4.579 - 1.571 + 6.820 = \mathbf{0.670 \text{ kJ/K}}$$

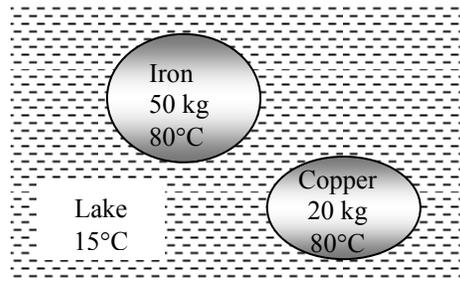

7-73 An adiabatic pump is used to compress saturated liquid water in a reversible manner. The work input is to be determined by different approaches.

Assumptions **1** Steady operating conditions exist. **2** Kinetic and potential energy changes are negligible. **3** Heat transfer to or from the fluid is negligible.

Analysis The properties of water at the inlet and exit of the pump are (Tables A-4 through A-6)

$$\left. \begin{array}{l} P_1 = 10 \text{ kPa} \\ x_1 = 0 \end{array} \right\} \begin{array}{l} h_1 = 191.81 \text{ kJ/kg} \\ s_1 = 0.6492 \text{ kJ/kg} \\ \nu_1 = 0.001010 \text{ m}^3/\text{kg} \end{array}$$

$$\left. \begin{array}{l} P_2 = 15 \text{ MPa} \\ s_2 = s_1 \end{array} \right\} \begin{array}{l} h_2 = 206.90 \text{ kJ/kg} \\ \nu_2 = 0.001004 \text{ m}^3/\text{kg} \end{array}$$

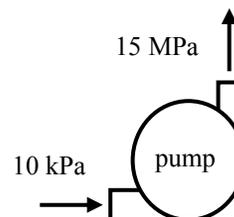

(a) Using the entropy data from the compressed liquid water table

$$w_p = h_2 - h_1 = 206.90 - 191.81 = \mathbf{15.10 \text{ kJ/kg}}$$

(b) Using inlet specific volume and pressure values

$$w_p = \nu_1 (P_2 - P_1) = (0.001010 \text{ m}^3/\text{kg})(15,000 - 10) \text{ kPa} = \mathbf{15.14 \text{ kJ/kg}}$$

$$\text{Error} = \mathbf{0.3\%}$$

(b) Using average specific volume and pressure values

$$w_p = \nu_{\text{avg}} (P_2 - P_1) = \left[1/2(0.001010 + 0.001004) \text{ m}^3/\text{kg} \right] (15,000 - 10) \text{ kPa} = \mathbf{15.10 \text{ kJ/kg}}$$

$$\text{Error} = \mathbf{0\%}$$

Discussion The results show that any of the method may be used to calculate reversible pump work.

Entropy Changes of Ideal Gases

7-74C For ideal gases, $c_p = c_v + R$ and

$$\frac{P_2 v_2}{T_2} = \frac{P_1 v_1}{T_1} \longrightarrow \frac{v_2}{v_1} = \frac{T_2 P_1}{T_1 P_2}$$

Thus,

$$\begin{aligned} s_2 - s_1 &= c_v \ln\left(\frac{T_2}{T_1}\right) + R \ln\left(\frac{v_2}{v_1}\right) \\ &= c_v \ln\left(\frac{T_2}{T_1}\right) + R \ln\left(\frac{T_2 P_1}{T_1 P_2}\right) \\ &= c_v \ln\left(\frac{T_2}{T_1}\right) + R \ln\left(\frac{T_2}{T_1}\right) - R \ln\left(\frac{P_2}{P_1}\right) \\ &= c_p \ln\left(\frac{T_2}{T_1}\right) - R \ln\left(\frac{P_2}{P_1}\right) \end{aligned}$$

7-75C For an ideal gas, $dh = c_p dT$ and $v = RT/P$. From the second Tds relation,

$$ds = \frac{dh}{T} - \frac{vdP}{T} = \frac{c_p dT}{T} - \frac{RT}{P} \frac{dP}{T} = c_p \frac{dT}{T} - R \frac{dP}{P}$$

Integrating,

$$s_2 - s_1 = c_p \ln\left(\frac{T_2}{T_1}\right) - R \ln\left(\frac{P_2}{P_1}\right)$$

Since c_p is assumed to be constant.

7-76C No. The entropy of an ideal gas depends on the pressure as well as the temperature.

7-77C Setting $\Delta s = 0$ gives

$$c_p \ln\left(\frac{T_2}{T_1}\right) - R \ln\left(\frac{P_2}{P_1}\right) = 0 \longrightarrow \ln\left(\frac{T_2}{T_1}\right) = \frac{R}{c_p} \ln\left(\frac{P_2}{P_1}\right) \longrightarrow \frac{T_2}{T_1} = \left(\frac{P_2}{P_1}\right)^{R/c_p}$$

But

$$\frac{R}{c_p} = \frac{c_p - c_v}{c_p} = 1 - \frac{1}{k} = \frac{k-1}{k} \quad \text{since} \quad k = c_p / c_v. \quad \text{Thus,} \quad \frac{T_2}{T_1} = \left(\frac{P_2}{P_1}\right)^{(k-1)/k}$$

7-78C The P_r and v_r are called relative pressure and relative specific volume, respectively. They are derived for isentropic processes of ideal gases, and thus their use is limited to isentropic processes only.

7-79C The entropy of a gas *can* change during an isothermal process since entropy of an ideal gas depends on the pressure as well as the temperature.

7-80C The entropy change relations of an ideal gas simplify to

$$\Delta s = c_p \ln(T_2/T_1) \text{ for a constant pressure process}$$

and $\Delta s = c_v \ln(T_2/T_1)$ for a constant volume process.

Noting that $c_p > c_v$, the entropy change will be larger for a constant pressure process.

7-81 The entropy difference between the two states of oxygen is to be determined.

Assumptions Oxygen is an ideal gas with constant specific heats.

Properties The specific heat of oxygen at the average temperature of $(39+337)/2=188^\circ\text{C}=461\text{ K}$ is $c_p = 0.960\text{ kJ/kg}\cdot\text{K}$ (Table A-2b).

Analysis From the entropy change relation of an ideal gas,

$$\Delta s_{\text{oxygen}} = c_p \ln \frac{T_2}{T_1} - R \ln \frac{P_2}{P_1} = (0.960\text{ kJ/kg}\cdot\text{K}) \ln \frac{(337+273)\text{K}}{(39+273)\text{K}} - 0 = \mathbf{0.6436\text{ kJ/kg}\cdot\text{K}}$$

since the pressure is same at the initial and final states.

7-82 The entropy changes of helium and nitrogen is to be compared for the same initial and final states.

Assumptions Helium and nitrogen are ideal gases with constant specific heats.

Properties The properties of helium are $c_p = 5.1926\text{ kJ/kg}\cdot\text{K}$, $R = 2.0769\text{ kJ/kg}\cdot\text{K}$ (Table A-2a). The specific heat of nitrogen at the average temperature of $(427+27)/2=227^\circ\text{C}=500\text{ K}$ is $c_p = 1.056\text{ kJ/kg}\cdot\text{K}$ (Table A-2b). The gas constant of nitrogen is $R = 0.2968\text{ kJ/kg}\cdot\text{K}$ (Table A-2a).

Analysis From the entropy change relation of an ideal gas,

$$\begin{aligned} \Delta s_{\text{He}} &= c_p \ln \frac{T_2}{T_1} - R \ln \frac{P_2}{P_1} \\ &= (5.1926\text{ kJ/kg}\cdot\text{K}) \ln \frac{(27+273)\text{K}}{(427+273)\text{K}} - (2.0769\text{ kJ/kg}\cdot\text{K}) \ln \frac{200\text{ kPa}}{2000\text{ kPa}} \\ &= \mathbf{0.3826\text{ kJ/kg}\cdot\text{K}} \end{aligned}$$

$$\begin{aligned} \Delta s_{\text{N}_2} &= c_p \ln \frac{T_2}{T_1} - R \ln \frac{P_2}{P_1} \\ &= (1.056\text{ kJ/kg}\cdot\text{K}) \ln \frac{(27+273)\text{K}}{(427+273)\text{K}} - (0.2968\text{ kJ/kg}\cdot\text{K}) \ln \frac{200\text{ kPa}}{2000\text{ kPa}} \\ &= \mathbf{-0.2113\text{ kJ/kg}\cdot\text{K}} \end{aligned}$$

Hence, helium undergoes the largest change in entropy.

7-83E The entropy change of air during an expansion process is to be determined.

Assumptions Air is an ideal gas with constant specific heats.

Properties The specific heat of air at the average temperature of $(500+50)/2=275^\circ\text{F}$ is $c_p = 0.243 \text{ Btu/lbm}\cdot\text{R}$ (Table A-2Eb). The gas constant of air is $R = 0.06855 \text{ Btu/lbm}\cdot\text{R}$ (Table A-2Ea).

Analysis From the entropy change relation of an ideal gas,

$$\begin{aligned}\Delta s_{\text{air}} &= c_p \ln \frac{T_2}{T_1} - R \ln \frac{P_2}{P_1} \\ &= (0.243 \text{ Btu/lbm}\cdot\text{R}) \ln \frac{(50+460)\text{R}}{(500+460)\text{R}} - (0.06855 \text{ Btu/lbm}\cdot\text{R}) \ln \frac{100 \text{ psia}}{200 \text{ psia}} \\ &= \mathbf{-0.1062 \text{ Btu/lbm}\cdot\text{R}}\end{aligned}$$

7-84 The final temperature of air when it is expanded isentropically is to be determined.

Assumptions Air is an ideal gas with constant specific heats.

Properties The specific heat ratio of air at an anticipated average temperature of 550 K is $k = 1.381$ (Table A-2b).

Analysis From the isentropic relation of an ideal gas under constant specific heat assumption,

$$T_2 = T_1 \left(\frac{P_2}{P_1} \right)^{(k-1)/k} = (477 + 273 \text{ K}) \left(\frac{100 \text{ kPa}}{1000 \text{ kPa}} \right)^{0.381/1.381} = \mathbf{397 \text{ K}}$$

Discussion The average air temperature is $(750+397.4)/2=573.7 \text{ K}$, which is sufficiently close to the assumed average temperature of 550 K.

7-85E The final temperature of air when it is expanded isentropically is to be determined.

Assumptions Air is an ideal gas with constant specific heats.

Properties The specific heat ratio of air at an anticipated average temperature of 300°F is $k = 1.394$ (Table A-2Eb).

Analysis From the isentropic relation of an ideal gas under constant specific heat assumption,

$$T_2 = T_1 \left(\frac{P_2}{P_1} \right)^{(k-1)/k} = (500 + 460 \text{ R}) \left(\frac{20 \text{ psia}}{100 \text{ psia}} \right)^{0.394/1.394} = \mathbf{609 \text{ R}}$$

Discussion The average air temperature is $(960+609)/2=785 \text{ R}=325^\circ\text{F}$, which is sufficiently close to the assumed average temperature of 300°F .

7-86 The final temperatures of helium and nitrogen when they are compressed isentropically are to be compared.

Assumptions Helium and nitrogen are ideal gases with constant specific heats.

Properties The specific heat ratios of helium and nitrogen at room temperature are $k = 1.667$ and $k = 1.4$, respectively (Table A-2a).

Analysis From the isentropic relation of an ideal gas under constant specific heat assumption,

$$T_{2,\text{He}} = T_1 \left(\frac{P_2}{P_1} \right)^{(k-1)/k} = (298 \text{ K}) \left(\frac{1000 \text{ kPa}}{100 \text{ kPa}} \right)^{0.667/1.667} = \mathbf{749 \text{ K}}$$

$$T_{2,\text{N}_2} = T_1 \left(\frac{P_2}{P_1} \right)^{(k-1)/k} = (298 \text{ K}) \left(\frac{1000 \text{ kPa}}{100 \text{ kPa}} \right)^{0.4/1.4} = \mathbf{575 \text{ K}}$$

Hence, the helium produces the greater temperature when it is compressed.

7-87 The final temperatures of neon and air when they are expanded isentropically are to be compared.

Assumptions Neon and air are ideal gases with constant specific heats.

Properties The specific heat ratios of neon and air at room temperature are $k = 1.667$ and $k = 1.4$, respectively (Table A-2a).

Analysis From the isentropic relation of an ideal gas under constant specific heat assumption,

$$T_{2,\text{Ne}} = T_1 \left(\frac{P_2}{P_1} \right)^{(k-1)/k} = (773 \text{ K}) \left(\frac{100 \text{ kPa}}{1000 \text{ kPa}} \right)^{0.667/1.667} = \mathbf{308 \text{ K}}$$

$$T_{2,\text{air}} = T_1 \left(\frac{P_2}{P_1} \right)^{(k-1)/k} = (773 \text{ K}) \left(\frac{100 \text{ kPa}}{1000 \text{ kPa}} \right)^{0.4/1.4} = \mathbf{400 \text{ K}}$$

Hence, the neon produces the smaller temperature when it is expanded.

7-88 An insulated cylinder initially contains air at a specified state. A resistance heater inside the cylinder is turned on, and air is heated for 15 min at constant pressure. The entropy change of air during this process is to be determined for the cases of constant and variable specific heats.

Assumptions At specified conditions, air can be treated as an ideal gas.

Properties The gas constant of air is $R = 0.287 \text{ kJ/kg}\cdot\text{K}$ (Table A-1).

Analysis The mass of the air and the electrical work done during this process are

$$m = \frac{P_1 V_1}{RT_1} = \frac{(120 \text{ kPa})(0.3 \text{ m}^3)}{(0.287 \text{ kPa}\cdot\text{m}^3/\text{kg}\cdot\text{K})(290 \text{ K})} = 0.4325 \text{ kg}$$

$$W_{e,\text{in}} = \dot{W}_{e,\text{in}} \Delta t = (0.2 \text{ kJ/s})(15 \times 60 \text{ s}) = 180 \text{ kJ}$$

The energy balance for this stationary closed system can be expressed as

$$\underbrace{E_{\text{in}} - E_{\text{out}}}_{\text{Net energy transfer by heat, work, and mass}} = \underbrace{\Delta E_{\text{system}}}_{\text{Change in internal, kinetic, potential, etc. energies}}$$

$$W_{e,\text{in}} - W_{b,\text{out}} = \Delta U \longrightarrow W_{e,\text{in}} = m(h_2 - h_1) \cong c_p(T_2 - T_1)$$

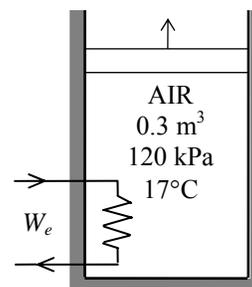

since $\Delta U + W_b = \Delta H$ during a constant pressure quasi-equilibrium process.

(a) Using a constant c_p value at the anticipated average temperature of 450 K, the final temperature becomes

$$\text{Thus, } T_2 = T_1 + \frac{W_{e,\text{in}}}{mc_p} = 290 \text{ K} + \frac{180 \text{ kJ}}{(0.4325 \text{ kg})(1.02 \text{ kJ/kg}\cdot\text{K})} = 698 \text{ K}$$

Then the entropy change becomes

$$\Delta S_{\text{sys}} = m(s_2 - s_1) = m \left(c_{p,\text{avg}} \ln \frac{T_2}{T_1} - R \ln \frac{P_2}{P_1} \right) = mc_{p,\text{avg}} \ln \frac{T_2}{T_1}$$

$$= (0.4325 \text{ kg})(1.020 \text{ kJ/kg}\cdot\text{K}) \ln \left(\frac{698 \text{ K}}{290 \text{ K}} \right) = \mathbf{0.387 \text{ kJ/K}}$$

(b) Assuming variable specific heats,

$$W_{e,\text{in}} = m(h_2 - h_1) \longrightarrow h_2 = h_1 + \frac{W_{e,\text{in}}}{m} = 290.16 \text{ kJ/kg} + \frac{180 \text{ kJ}}{0.4325 \text{ kg}} = 706.34 \text{ kJ/kg}$$

From the air table (Table A-17, we read $s_2^\circ = 2.5628 \text{ kJ/kg}\cdot\text{K}$ corresponding to this h_2 value. Then,

$$\Delta S_{\text{sys}} = m \left(s_2^\circ - s_1^\circ + R \ln \frac{P_2}{P_1} \right) = m(s_2^\circ - s_1^\circ) = (0.4325 \text{ kg})(2.5628 - 1.66802) \text{ kJ/kg}\cdot\text{K} = \mathbf{0.387 \text{ kJ/K}}$$

7-89 A cylinder contains N_2 gas at a specified pressure and temperature. A gas is compressed polytropically until the volume is reduced by half. The entropy change of nitrogen during this process is to be determined.

Assumptions **1** At specified conditions, N_2 can be treated as an ideal gas. **2** Nitrogen has constant specific heats at room temperature.

Properties The gas constant of nitrogen is $R = 0.297 \text{ kJ/kg}\cdot\text{K}$ (Table A-1). The constant volume specific heat of nitrogen at room temperature is $c_v = 0.743 \text{ kJ/kg}\cdot\text{K}$ (Table A-2).

Analysis From the polytropic relation,

$$\frac{T_2}{T_1} = \left(\frac{v_1}{v_2}\right)^{n-1} \longrightarrow T_2 = T_1 \left(\frac{v_1}{v_2}\right)^{n-1} = (300 \text{ K})(2)^{1.3-1} = 369.3 \text{ K}$$

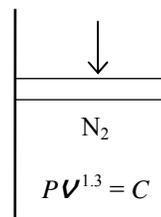

Then the entropy change of nitrogen becomes

$$\begin{aligned} \Delta S_{N_2} &= m \left(c_{v,\text{avg}} \ln \frac{T_2}{T_1} + R \ln \frac{v_2}{v_1} \right) \\ &= (1.2 \text{ kg}) \left((0.743 \text{ kJ/kg}\cdot\text{K}) \ln \frac{369.3 \text{ K}}{300 \text{ K}} + (0.297 \text{ kJ/kg}\cdot\text{K}) \ln(0.5) \right) = \mathbf{-0.0617 \text{ kJ/K}} \end{aligned}$$

7-90 EES Problem 7-89 is reconsidered. The effect of varying the polytropic exponent from 1 to 1.4 on the entropy change of the nitrogen is to be investigated, and the processes are to be shown on a common P - v diagram.

Analysis The problem is solved using EES, and the results are tabulated and plotted below.

```
Function BoundWork(P[1],V[1],P[2],V[2],n)
"This function returns the Boundary Work for the polytropic process. This function is required
since the expression for boundary work depends on whether n=1 or n<>1"
  If n<>1 then
    BoundWork:=(P[2]*V[2]-P[1]*V[1])/(1-n)"Use Equation 3-22 when n=1"
  else
    BoundWork:= P[1]*V[1]*ln(V[2]/V[1]) "Use Equation 3-20 when n=1"
  endif
end

n=1
P[1] = 120 [kPa]
T[1] = 27 [C]
m = 1.2 [kg]
V[2]=V[1]/2
Gas$='N2'
MM=molarmass(Gas$)
R=R_u/MM
R_u=8.314 [kJ/kmol-K]
"System: The gas enclosed in the piston-cylinder device."
"Process: Polytropic expansion or compression, P*V^n = C"
P[1]*V[1]=m*R*(T[1]+273)
P[2]*V[2]^n=P[1]*V[1]^n
W_b = BoundWork(P[1],V[1],P[2],V[2],n)
"Find the temperature at state 2 from the pressure and specific volume."
T[2]=temperature(gas$,P=P[2],v=V[2]/m)
"The entropy at states 1 and 2 is:"
s[1]=entropy(gas$,P=P[1],v=V[1]/m)
s[2]=entropy(gas$,P=P[2],v=V[2]/m)
DELTAS=m*(s[2] - s[1])
"Remove the {} to generate the P-v plot data"
{Nsteps = 10
VP[1]=V[1]
PP[1]=P[1]
Duplicate i=2,Nsteps
  VP[i]=V[1]-i*(V[1]-V[2])/Nsteps
  PP[i]=P[1]*(V[1]/VP[i])^n
END }
```

ΔS [kJ/kg]	n	W_b [kJ]
-0.2469	1	-74.06
-0.2159	1.05	-75.36
-0.1849	1.1	-76.69
-0.1539	1.15	-78.05
-0.1229	1.2	-79.44
-0.09191	1.25	-80.86
-0.06095	1.3	-82.32
-0.02999	1.35	-83.82
0.0009849	1.4	-85.34

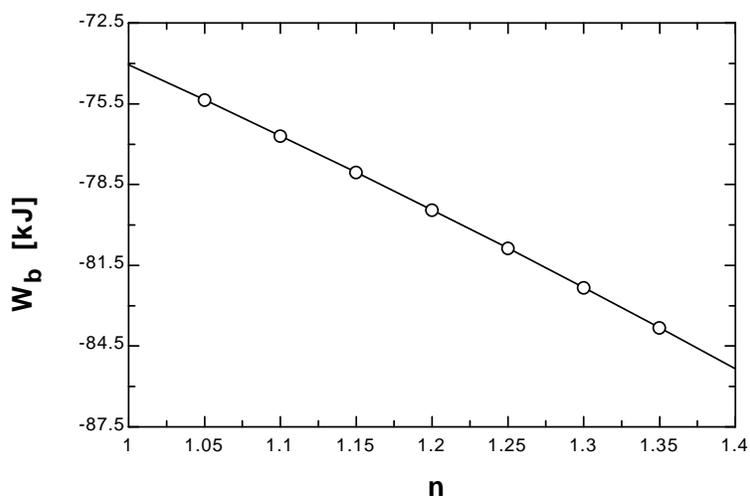
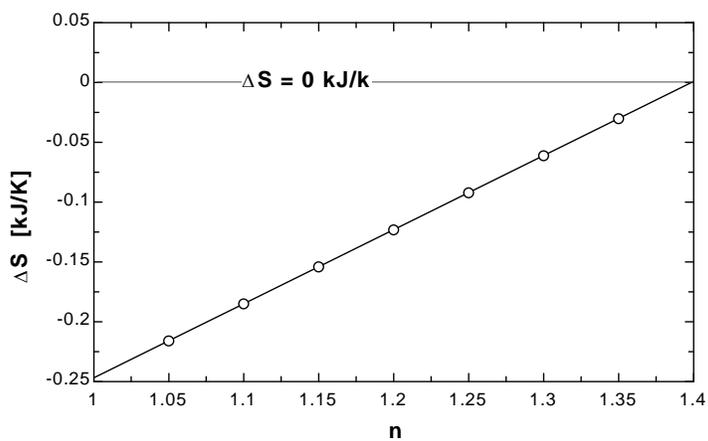
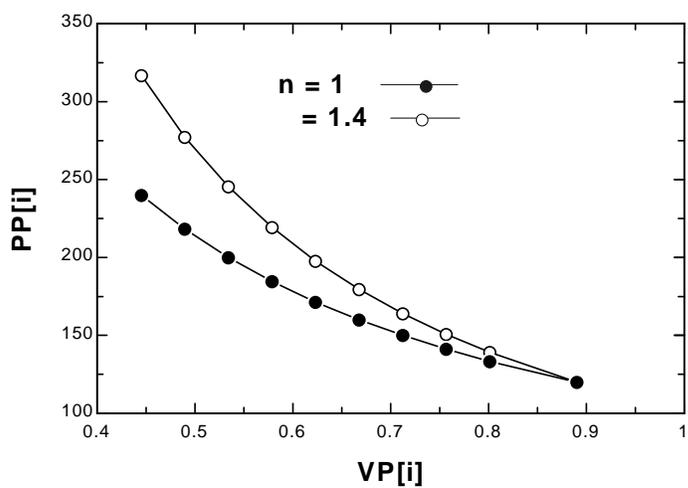

7-91E A fixed mass of helium undergoes a process from one specified state to another specified state. The entropy change of helium is to be determined for the cases of reversible and irreversible processes.

Assumptions 1 At specified conditions, helium can be treated as an ideal gas. **2** Helium has constant specific heats at room temperature.

Properties The gas constant of helium is $R = 0.4961 \text{ Btu/lbm}\cdot\text{R}$ (Table A-1E). The constant volume specific heat of helium is $c_v = 0.753 \text{ Btu/lbm}\cdot\text{R}$ (Table A-2E).

Analysis From the ideal-gas entropy change relation,

$$\begin{aligned}\Delta S_{\text{He}} &= m \left(c_{v,\text{ave}} \ln \frac{T_2}{T_1} + R \ln \frac{v_2}{v_1} \right) \\ &= (15 \text{ lbm}) \left((0.753 \text{ Btu/lbm}\cdot\text{R}) \ln \frac{660 \text{ R}}{540 \text{ R}} + (0.4961 \text{ Btu/lbm}\cdot\text{R}) \ln \left(\frac{10 \text{ ft}^3/\text{lbm}}{50 \text{ ft}^3/\text{lbm}} \right) \right) \\ &= \mathbf{-9.71 \text{ Btu/R}}\end{aligned}$$

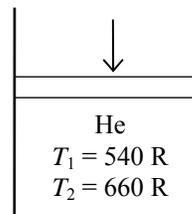

The entropy change will be the same for both cases.

7-92 One side of a partitioned insulated rigid tank contains an ideal gas at a specified temperature and pressure while the other side is evacuated. The partition is removed, and the gas fills the entire tank. The total entropy change during this process is to be determined.

Assumptions The gas in the tank is given to be an ideal gas, and thus ideal gas relations apply.

Analysis Taking the entire rigid tank as the system, the energy balance can be expressed as

$$\begin{aligned}\underbrace{E_{\text{in}} - E_{\text{out}}}_{\text{Net energy transfer by heat, work, and mass}} &= \underbrace{\Delta E_{\text{system}}}_{\text{Change in internal, kinetic, potential, etc. energies}} \\ 0 &= \Delta U = m(u_2 - u_1) \\ u_2 &= u_1 \\ T_2 &= T_1\end{aligned}$$

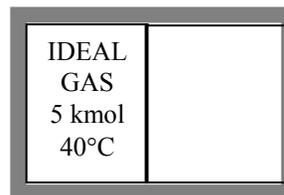

since $u = u(T)$ for an ideal gas. Then the entropy change of the gas becomes

$$\begin{aligned}\Delta S &= N \left(\bar{c}_{v,\text{avg}} \ln \frac{T_2}{T_1} + R_u \ln \frac{v_2}{v_1} \right) = NR_u \ln \frac{v_2}{v_1} \\ &= (5 \text{ kmol})(8.314 \text{ kJ/kmol}\cdot\text{K}) \ln(2) \\ &= \mathbf{28.81 \text{ kJ/K}}\end{aligned}$$

This also represents the **total entropy change** since the tank does not contain anything else, and there are no interactions with the surroundings.

7-93 Air is compressed in a piston-cylinder device in a reversible and adiabatic manner. The final temperature and the work are to be determined for the cases of constant and variable specific heats.

Assumptions 1 At specified conditions, air can be treated as an ideal gas. **2** The process is given to be reversible and adiabatic, and thus isentropic. Therefore, isentropic relations of ideal gases apply.

Properties The gas constant of air is $R = 0.287 \text{ kJ/kg}\cdot\text{K}$ (Table A-1). The specific heat ratio of air at low to moderately high temperatures is $k = 1.4$ (Table A-2).

Analysis (a) Assuming constant specific heats, the ideal gas isentropic relations give

$$T_2 = T_1 \left(\frac{P_2}{P_1} \right)^{(k-1)/k} = (290 \text{ K}) \left(\frac{800 \text{ kPa}}{100 \text{ kPa}} \right)^{0.4/1.4} = \mathbf{525.3 \text{ K}}$$

Then,

$$T_{\text{avg}} = (290 + 525.3)/2 = 407.7 \text{ K} \longrightarrow c_{\nu, \text{avg}} = 0.727 \text{ kJ/kg}\cdot\text{K}$$

We take the air in the cylinder as the system. The energy balance for this stationary closed system can be expressed as

$$\underbrace{E_{\text{in}} - E_{\text{out}}}_{\substack{\text{Net energy transfer} \\ \text{by heat, work, and mass}}} = \underbrace{\Delta E_{\text{system}}}_{\substack{\text{Change in internal, kinetic,} \\ \text{potential, etc. energies}}}$$

$$W_{\text{in}} = \Delta U = m(u_2 - u_1) \cong mc_{\nu}(T_2 - T_1)$$

Thus,

$$w_{\text{in}} = c_{\nu, \text{avg}}(T_2 - T_1) = (0.727 \text{ kJ/kg}\cdot\text{K})(525.3 - 290) \text{ K} = \mathbf{171.1 \text{ kJ/kg}}$$

(b) Assuming variable specific heats, the final temperature can be determined using the relative pressure data (Table A-17),

$$T_1 = 290 \text{ K} \longrightarrow \begin{aligned} P_{r_1} &= 1.2311 \\ u_1 &= 206.91 \text{ kJ/kg} \end{aligned}$$

and

$$P_{r_2} = \frac{P_2}{P_1} P_{r_1} = \frac{800 \text{ kPa}}{100 \text{ kPa}} (1.2311) = 9.849 \longrightarrow \begin{aligned} T_2 &= \mathbf{522.4 \text{ K}} \\ u_2 &= 376.16 \text{ kJ/kg} \end{aligned}$$

Then the work input becomes

$$w_{\text{in}} = u_2 - u_1 = (376.16 - 206.91) \text{ kJ/kg} = \mathbf{169.25 \text{ kJ/kg}}$$

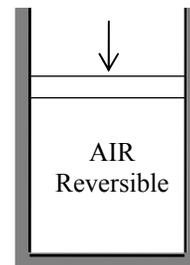

7-94 EES Problem 7-93 is reconsidered. The work done and final temperature during the compression process are to be calculated and plotted as functions of the final pressure for the two cases as the final pressure varies from 100 kPa to 800 kPa.

Analysis The problem is solved using EES, and the results are tabulated and plotted below.

```

Procedure ConstPropSol(P_1,T_1,P_2,Gas$:Work_in_ConstProp,T2_ConstProp)
C_P=SPECHEAT(Gas$,T=27)
MM=MOLARMASS(Gas$)
R_u=8.314 [kJ/kmol-K]
R=R_u/MM
C_V = C_P - R
k = C_P/C_V
T2= (T_1+273)*(P_2/P_1)^((k-1)/k)
T2_ConstProp=T2-273 "[C]"
DELTAu = C_v*(T2-(T_1+273))
Work_in_ConstProp = DELTAu
End

```

"Knowns:"

P_1 = 100 [kPa]

T_1 = 17 [C]

P_2 = 800 [kPa]

"Analysis: "

" Treat the piston-cylinder as a closed system, with no heat transfer in, neglect changes in KE and PE of the air. The process is reversible and adiabatic thus isentropic."

"The isentropic work is determined from:"

e_in - e_out = DELTAe_sys

e_out = 0 [kJ/kg]

e_in = Work_in

DELTAe_sys = (u_2 - u_1)

u_1 = INTENERGY(air,T=T_1)

v_1 = volume(air,P=P_1,T=T_1)

s_1 = entropy(air,P=P_1,T=T_1)

" The process is reversible and adiabatic or isentropic.

Then P_2 and s_2 specify state 2."

s_2 = s_1

u_2 = INTENERGY(air,P=P_2,s=s_2)

T_2_isen=temperature(air,P=P_2,s=s_2)

Gas\$ = 'air'

Call ConstPropSol(P_1,T_1,P_2,Gas\$:

Work_in_ConstProp,T2_ConstProp)

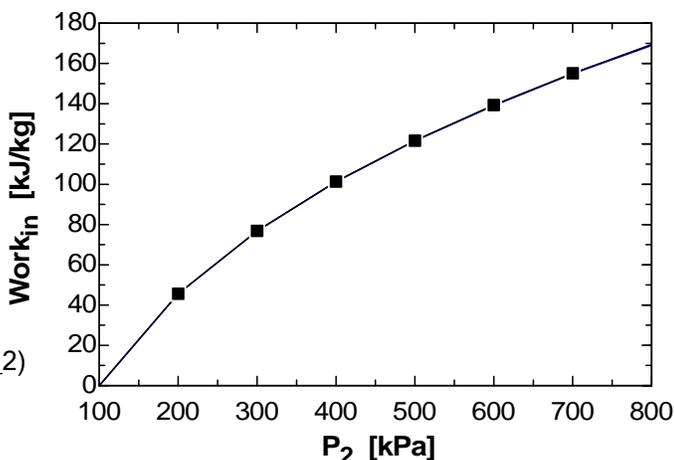

P ₂ [kPa]	Work _{in} [kJ/kg]	Work _{in,ConstProp} [kJ/kg]
100	0	0
200	45.63	45.6
300	76.84	76.77
400	101.3	101.2
500	121.7	121.5
600	139.4	139.1
700	155.2	154.8
800	169.3	168.9

7-95 An insulated rigid tank contains argon gas at a specified pressure and temperature. A valve is opened, and argon escapes until the pressure drops to a specified value. The final mass in the tank is to be determined.

Assumptions **1** At specified conditions, argon can be treated as an ideal gas. **2** The process is given to be reversible and adiabatic, and thus isentropic. Therefore, isentropic relations of ideal gases apply.

Properties The specific heat ratio of argon is $k = 1.667$ (Table A-2).

Analysis From the ideal gas isentropic relations,

$$T_2 = T_1 \left(\frac{P_2}{P_1} \right)^{(k-1)/k} = (303 \text{ K}) \left(\frac{200 \text{ kPa}}{450 \text{ kPa}} \right)^{0.667/1.667} = 219.0 \text{ K}$$

The final mass in the tank is determined from the ideal gas relation,

$$\frac{P_1 \mathcal{V}}{P_2 \mathcal{V}} = \frac{m_1 RT_1}{m_2 RT_2} \longrightarrow m_2 = \frac{P_2 T_1}{P_1 T_2} m_1 = \frac{(200 \text{ kPa})(303 \text{ K})}{(450 \text{ kPa})(219 \text{ K})} (4 \text{ kg}) = \mathbf{2.46 \text{ kg}}$$

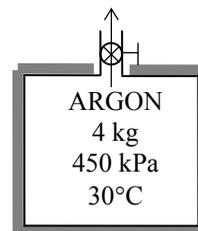

7-96 EES Problem 7-95 is reconsidered. The effect of the final pressure on the final mass in the tank is to be investigated as the pressure varies from 450 kPa to 150 kPa, and the results are to be plotted.

Analysis The problem is solved using EES, and the results are tabulated and plotted below.

"Knowns:"

C_P = 0.5203 "[kJ/kg-K]"
 C_V = 0.3122 "[kJ/kg-K]"
 R = 0.2081 "[kPa-m^3/kg-K]"
 P_1 = 450 "[kPa]"
 T_1 = 30 "[C]"
 m_1 = 4 "[kg]"
 P_2 = 150 "[kPa]"

"Analysis:"

We assume the mass that stays in the tank undergoes an isentropic expansion process. This allows us to determine the final temperature of that gas at the final pressure in the tank by using the isentropic relation:"

$k = C_P / C_V$
 $T_2 = ((T_1 + 273) * (P_2 / P_1)^{((k-1)/k)} - 273) "[C]"$
 $V_2 = V_1$
 $P_1 * V_1 = m_1 * R * (T_1 + 273)$
 $P_2 * V_2 = m_2 * R * (T_2 + 273)$

m ₂ [kg]	P ₂ [kPa]
2.069	150
2.459	200
2.811	250
3.136	300
3.44	350
3.727	400
4	450

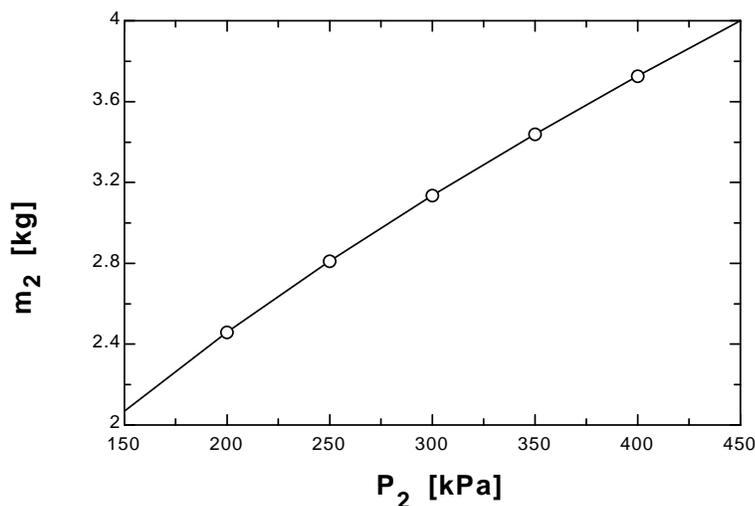

7-97E Air is accelerated in an adiabatic nozzle. Disregarding irreversibilities, the exit velocity of air is to be determined.

Assumptions **1** Air is an ideal gas with variable specific heats. **2** The process is given to be reversible and adiabatic, and thus isentropic. Therefore, isentropic relations of ideal gases apply. **2** The nozzle operates steadily.

Analysis Assuming variable specific heats, the inlet and exit properties are determined to be

$$T_1 = 1000 \text{ R} \longrightarrow \begin{matrix} P_{r_1} = 12.30 \\ h_1 = 240.98 \text{ Btu/lbm} \end{matrix}$$

and

$$P_{r_2} = \frac{P_2}{P_1} P_{r_1} = \frac{12 \text{ psia}}{60 \text{ psia}} (12.30) = 2.46 \longrightarrow \begin{matrix} T_2 = 635.9 \text{ R} \\ h_2 = 152.11 \text{ Btu/lbm} \end{matrix}$$

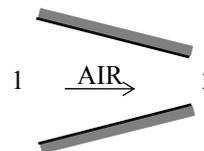

We take the nozzle as the system, which is a control volume. The energy balance for this steady-flow system can be expressed in the rate form as

$$\underbrace{\dot{E}_{\text{in}} - \dot{E}_{\text{out}}}_{\text{Rate of net energy transfer by heat, work, and mass}} = \underbrace{\Delta \dot{E}_{\text{system}}}_{\text{Rate of change in internal, kinetic, potential, etc. energies}} \stackrel{\text{no}}{=} 0 \quad (\text{steady})$$

$$\dot{E}_{\text{in}} = \dot{E}_{\text{out}}$$

$$\dot{m}(h_1 + V_1^2/2) = \dot{m}(h_2 + V_2^2/2)$$

$$h_2 - h_1 + \frac{V_2^2 - V_1^2}{2} = 0$$

Therefore,

$$\begin{aligned} V_2 &= \sqrt{2(h_1 - h_2) + V_1^2} = \sqrt{2(240.98 - 152.11) \text{ Btu/lbm} \left(\frac{25,037 \text{ ft}^2/\text{s}^2}{1 \text{ Btu/lbm}} \right) + (200 \text{ ft/s})^2} \\ &= \mathbf{2119 \text{ ft/s}} \end{aligned}$$

7-98E Air is expanded in an isentropic turbine. The exit temperature of the air and the power produced are to be determined.

Assumptions 1 This is a steady-flow process since there is no change with time. **2** The process is isentropic (i.e., reversible-adiabatic). **3** Air is an ideal gas with constant specific heats.

Properties The properties of air at an anticipated average temperature of 600°F are $c_p = 0.250$ Btu/lbm·R and $k = 1.377$ (Table A-2Eb). The gas constant of air is $R = 0.3704$ psia·ft³/lbm·R (Table A-1E).

Analysis There is only one inlet and one exit, and thus $\dot{m}_1 = \dot{m}_2 = \dot{m}$. We take the turbine as the system, which is a control volume since mass crosses the boundary. The energy balance for this steady-flow system can be expressed in the rate form as

$$\underbrace{\dot{E}_{\text{in}} - \dot{E}_{\text{out}}}_{\text{Rate of net energy transfer by heat, work, and mass}} = \underbrace{\Delta \dot{E}_{\text{system}}}_{\text{Rate of change in internal, kinetic, potential, etc. energies}} \stackrel{\approx 0 \text{ (steady)}}{=} 0$$

$$\dot{E}_{\text{in}} = \dot{E}_{\text{out}}$$

$$\dot{m} \left(h_1 + \frac{V_1^2}{2} \right) = \dot{m} \left(h_2 + \frac{V_2^2}{2} \right) + \dot{W}_{\text{out}}$$

$$\begin{aligned} \dot{W}_{\text{out}} &= \dot{m} \left(h_1 - h_2 + \frac{V_1^2 - V_2^2}{2} \right) \\ &= \dot{m} \left(c_p (T_1 - T_2) + \frac{V_1^2 - V_2^2}{2} \right) \end{aligned}$$

The exit temperature of the air for this isentropic process is

$$T_2 = T_1 \left(\frac{P_2}{P_1} \right)^{(k-1)/k} = (900 + 460 \text{ R}) \left(\frac{15 \text{ psia}}{150 \text{ psia}} \right)^{0.377/1.377} = \mathbf{724 \text{ R}}$$

The specific volume of air at the inlet and the mass flow rate are

$$\nu_1 = \frac{RT_1}{P_1} = \frac{(0.3704 \text{ psia} \cdot \text{ft}^3/\text{lbm} \cdot \text{R})(900 + 460 \text{ R})}{150 \text{ psia}} = 3.358 \text{ ft}^3/\text{lbm}$$

$$\dot{m} = \frac{A_1 V_1}{\nu_1} = \frac{(0.5 \text{ ft}^2)(500 \text{ ft/s})}{3.358 \text{ ft}^3/\text{lbm}} = 74.45 \text{ lbm/s}$$

Substituting into the energy balance equation gives

$$\begin{aligned} \dot{W}_{\text{out}} &= \dot{m} \left(c_p (T_1 - T_2) + \frac{V_1^2 - V_2^2}{2} \right) \\ &= (74.45 \text{ lbm/s}) \left[(0.250 \text{ Btu/lbm} \cdot \text{R})(1360 - 724) \text{ R} + \frac{(500 \text{ ft/s})^2 - (100 \text{ ft/s})^2}{2} \left(\frac{1 \text{ Btu/lbm}}{25,037 \text{ ft}^2/\text{s}^2} \right) \right] \\ &= 12,194 \text{ Btu/s} \left(\frac{1 \text{ hp}}{0.7068 \text{ Btu/s}} \right) = \mathbf{17,250 \text{ hp}} \end{aligned}$$

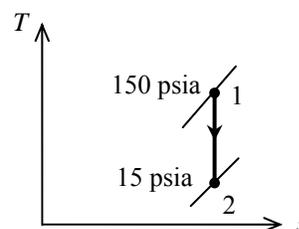
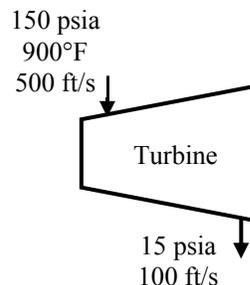

7-99 Nitrogen is compressed in an adiabatic compressor. The minimum work input is to be determined.

Assumptions 1 This is a steady-flow process since there is no change with time. **2** The process is adiabatic, and thus there is no heat transfer. **3** Nitrogen is an ideal gas with constant specific heats.

Properties The properties of nitrogen at an anticipated average temperature of 400 K are $c_p = 1.044$ kJ/kg·K and $k = 1.397$ (Table A-2b).

Analysis There is only one inlet and one exit, and thus $\dot{m}_1 = \dot{m}_2 = \dot{m}$. We take the compressor as the system, which is a control volume since mass crosses the boundary. The energy balance for this steady-flow system can be expressed in the rate form as

$$\underbrace{\dot{E}_{\text{in}} - \dot{E}_{\text{out}}}_{\text{Rate of net energy transfer by heat, work, and mass}} = \underbrace{\Delta \dot{E}_{\text{system}}}_{\text{Rate of change in internal, kinetic, potential, etc. energies}} \stackrel{\approx 0 \text{ (steady)}}{=} 0$$

$$\dot{E}_{\text{in}} = \dot{E}_{\text{out}}$$

$$\dot{m}h_1 + \dot{W}_{\text{in}} = \dot{m}h_2$$

$$\dot{W}_{\text{in}} = \dot{m}(h_2 - h_1)$$

For the minimum work input to the compressor, the process must be reversible as well as adiabatic (i.e., isentropic). This being the case, the exit temperature will be

$$T_2 = T_1 \left(\frac{P_2}{P_1} \right)^{(k-1)/k} = (303 \text{ K}) \left(\frac{600 \text{ kPa}}{120 \text{ kPa}} \right)^{0.397/1.397} = 479 \text{ K}$$

Substituting into the energy balance equation gives

$$w_{\text{in}} = h_2 - h_1 = c_p (T_2 - T_1) = (1.044 \text{ kJ/kg} \cdot \text{K})(479 - 303) \text{ K} = \mathbf{184 \text{ kJ/kg}}$$

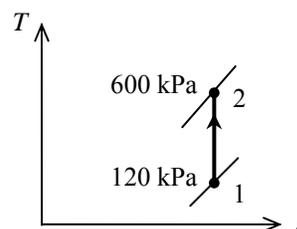
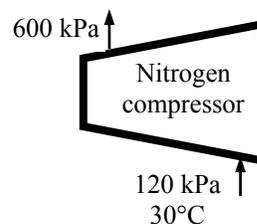

7-100 Oxygen is expanded in an adiabatic nozzle. The maximum velocity at the exit is to be determined.

Assumptions 1 This is a steady-flow process since there is no change with time. **2** The process is adiabatic, and thus there is no heat transfer. **3** Oxygen is an ideal gas with constant specific heats.

Properties The properties of oxygen at room temperature are $c_p = 0.918 \text{ kJ/kg}\cdot\text{K}$ and $k = 1.395$ (Table A-2a).

Analysis For the maximum velocity at the exit, the process must be reversible as well as adiabatic (i.e., isentropic). This being the case, the exit temperature will be

$$T_2 = T_1 \left(\frac{P_2}{P_1} \right)^{(k-1)/k} = (363 \text{ K}) \left(\frac{120 \text{ kPa}}{300 \text{ kPa}} \right)^{0.395/1.395} = 280.0 \text{ K}$$

There is only one inlet and one exit, and thus $\dot{m}_1 = \dot{m}_2 = \dot{m}$. We take nozzle as the system, which is a control volume since mass crosses the boundary. The energy balance for this steady-flow system can be expressed in the rate form as

$$\underbrace{\dot{E}_{\text{in}} - \dot{E}_{\text{out}}}_{\text{Rate of net energy transfer by heat, work, and mass}} = \underbrace{\Delta \dot{E}_{\text{system}}^{\text{no}}}_{\text{Rate of change in internal, kinetic, potential, etc. energies (steady)}} = 0$$

$$\dot{E}_{\text{in}} = \dot{E}_{\text{out}}$$

$$\dot{m} \left(h_1 + \frac{V_1^2}{2} \right) = \dot{m} \left(h_2 + \frac{V_2^2}{2} \right)$$

$$h_1 + \frac{V_1^2}{2} = h_2 + \frac{V_2^2}{2}$$

Solving for the exit velocity,

$$\begin{aligned} V_2 &= \left[V_1^2 + 2(h_1 - h_2) \right]^{0.5} \\ &= \left[V_1^2 + 2c_p(T_1 - T_2) \right]^{0.5} \\ &= \left[(3 \text{ m/s})^2 + 2(0.918 \text{ kJ/kg}\cdot\text{K})(363 - 280) \text{ K} \left(\frac{1000 \text{ m}^2/\text{s}^2}{1 \text{ kJ/kg}} \right) \right]^{0.5} \\ &= \mathbf{390 \text{ m/s}} \end{aligned}$$

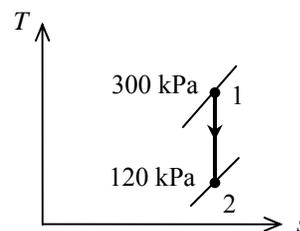
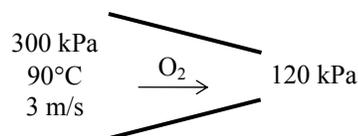

7-101 Air is expanded in an adiabatic nozzle by a polytropic process. The temperature and velocity at the exit are to be determined.

Assumptions 1 This is a steady-flow process since there is no change with time. **2** There is no heat transfer or shaft work associated with the process. **3** Air is an ideal gas with constant specific heats.

Properties The properties of air at room temperature are $c_p = 1.005 \text{ kJ/kg}\cdot\text{K}$ and $k = 1.4$ (Table A-2a).

Analysis For the polytropic process of an ideal gas, $Pv^n = \text{Constant}$, and the exit temperature is given by

$$T_2 = T_1 \left(\frac{P_2}{P_1} \right)^{(n-1)/n} = (373 \text{ K}) \left(\frac{200 \text{ kPa}}{700 \text{ kPa}} \right)^{0.3/1.3} = \mathbf{279 \text{ K}}$$

There is only one inlet and one exit, and thus $\dot{m}_1 = \dot{m}_2 = \dot{m}$. We take nozzle as the system, which is a control volume since mass crosses the boundary. The energy balance for this steady-flow system can be expressed in the rate form as

$$\underbrace{\dot{E}_{\text{in}} - \dot{E}_{\text{out}}}_{\text{Rate of net energy transfer by heat, work, and mass}} = \underbrace{\Delta \dot{E}_{\text{system}}}_{\text{Rate of change in internal, kinetic, potential, etc. energies}} \stackrel{\text{no (steady)}}{=} 0$$

$$\dot{E}_{\text{in}} = \dot{E}_{\text{out}}$$

$$\dot{m} \left(h_1 + \frac{V_1^2}{2} \right) = \dot{m} \left(h_2 + \frac{V_2^2}{2} \right)$$

$$h_1 + \frac{V_1^2}{2} = h_2 + \frac{V_2^2}{2}$$

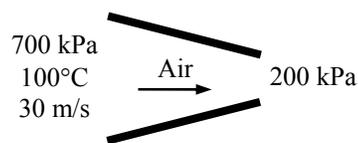

Solving for the exit velocity,

$$\begin{aligned} V_2 &= \left[V_1^2 + 2(h_1 - h_2) \right]^{0.5} \\ &= \left[V_1^2 + 2c_p(T_1 - T_2) \right]^{0.5} \\ &= \left[(30 \text{ m/s})^2 + 2(1.005 \text{ kJ/kg}\cdot\text{K})(373 - 279) \text{ K} \left(\frac{1000 \text{ m}^2/\text{s}^2}{1 \text{ kJ/kg}} \right) \right]^{0.5} \\ &= \mathbf{436 \text{ m/s}} \end{aligned}$$

7-102 Air is expanded in an adiabatic nozzle by a polytropic process. The temperature and velocity at the exit are to be determined.

Assumptions **1** This is a steady-flow process since there is no change with time. **2** There is no heat transfer or shaft work associated with the process. **3** Air is an ideal gas with constant specific heats.

Properties The properties of air at room temperature are $c_p = 1.005 \text{ kJ/kg}\cdot\text{K}$ and $k = 1.4$ (Table A-2a).

Analysis For the polytropic process of an ideal gas, $P\nu^n = \text{Constant}$, and the exit temperature is given by

$$T_2 = T_1 \left(\frac{P_2}{P_1} \right)^{(n-1)/n} = (373 \text{ K}) \left(\frac{200 \text{ kPa}}{700 \text{ kPa}} \right)^{0.2/1.2} = \mathbf{303 \text{ K}}$$

There is only one inlet and one exit, and thus $\dot{m}_1 = \dot{m}_2 = \dot{m}$. We take nozzle as the system, which is a control volume since mass crosses the boundary. The energy balance for this steady-flow system can be expressed in the rate form as

$$\underbrace{\dot{E}_{\text{in}} - \dot{E}_{\text{out}}}_{\text{Rate of net energy transfer by heat, work, and mass}} = \underbrace{\Delta \dot{E}_{\text{system}}}_{\text{Rate of change in internal, kinetic, potential, etc. energies}} \stackrel{\text{no (steady)}}{=} 0$$

$$\dot{E}_{\text{in}} = \dot{E}_{\text{out}}$$

$$\dot{m} \left(h_1 + \frac{V_1^2}{2} \right) = \dot{m} \left(h_2 + \frac{V_2^2}{2} \right)$$

$$h_1 + \frac{V_1^2}{2} = h_2 + \frac{V_2^2}{2}$$

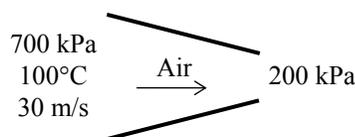

Solving for the exit velocity,

$$\begin{aligned} V_2 &= \left[V_1^2 + 2(h_1 - h_2) \right]^{0.5} \\ &= \left[V_1^2 + 2c_p(T_1 - T_2) \right]^{0.5} \\ &= \left[(30 \text{ m/s})^2 + 2(1.005 \text{ kJ/kg}\cdot\text{K})(373 - 303) \text{ K} \left(\frac{1000 \text{ m}^2/\text{s}^2}{1 \text{ kJ/kg}} \right) \right]^{0.5} \\ &= \mathbf{376 \text{ m/s}} \end{aligned}$$

7-103 Air is charged to an initially evacuated container from a supply line. The minimum temperature of the air in the container after it is filled is to be determined.

Assumptions 1 This is an unsteady process since the conditions within the device are changing during the process, but it can be analyzed as a uniform-flow process since the state of fluid at the inlet remains constant. **2** Air is an ideal gas with constant specific heats. **3** Kinetic and potential energies are negligible. **4** There are no work interactions involved. **5** The tank is well-insulated, and thus there is no heat transfer.

Properties The specific heat of air at room temperature is $c_p = 0.240$ Btu/lbm·R (Table A-2Ea).

Analysis We take the tank as the system, which is a control volume since mass crosses the boundary. Noting that the microscopic energies of flowing and nonflowing fluids are represented by enthalpy h and internal energy u , respectively, the mass and entropy balances for this uniform-flow system can be expressed as

Mass balance:

$$m_{\text{in}} - m_{\text{out}} = \Delta m_{\text{system}}$$

$$m_i = m_2 - m_1$$

$$m_i = m_2$$

Entropy balance:

$$m_2 s_2 - m_1 s_1 + m_e s_e - m_i s_i \geq 0$$

$$m_2 s_2 - m_i s_i \geq 0$$

Combining the two balances,

$$m_2 s_2 - m_2 s_i \geq 0$$

$$s_2 - s_i \geq 0$$

The minimum temperature will result when the equal sign applies. Noting that $P_2 = P_i$, we have

$$s_2 - s_i = c_p \ln \frac{T_2}{T_i} - R \ln \frac{P_2}{P_i} = 0 \longrightarrow c_p \ln \frac{T_2}{T_i} = 0$$

Then,

$$T_2 = T_i = \mathbf{100^\circ\text{F}}$$

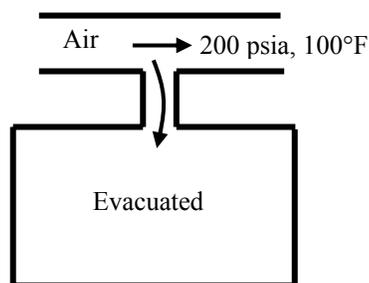

7-104 A container is filled with liquid water is placed in a room and heat transfer takes place between the container and the air in the room until the thermal equilibrium is established. The final temperature, the amount of heat transfer between the water and the air, and the entropy generation are to be determined.

Assumptions **1** Kinetic and potential energy changes are negligible. **2** Air is an ideal gas with constant specific heats. **3** The room is well-sealed and there is no heat transfer from the room to the surroundings. **4** Sea level atmospheric pressure is assumed. $P = 101.3 \text{ kPa}$.

Properties The properties of air at room temperature are $R = 0.287 \text{ kPa}\cdot\text{m}^3/\text{kg}\cdot\text{K}$, $c_p = 1.005 \text{ kJ}/\text{kg}\cdot\text{K}$, $c_v = 0.718 \text{ kJ}/\text{kg}\cdot\text{K}$. The specific heat of water at room temperature is $c_w = 4.18 \text{ kJ}/\text{kg}\cdot\text{K}$ (Tables A-2, A-3).

Analysis (a) The mass of the air in the room is

$$m_a = \frac{P\mathcal{V}}{RT_{a1}} = \frac{(101.3 \text{ kPa})(90 \text{ m}^3)}{(0.287 \text{ kPa}\cdot\text{m}^3/\text{kg}\cdot\text{K})(12 + 273 \text{ K})} = 111.5 \text{ kg}$$

An energy balance on the system that consists of the water in the container and the air in the room gives the final equilibrium temperature

$$0 = m_w c_w (T_2 - T_{w1}) + m_a c_v (T_2 - T_{a1})$$

$$0 = (45 \text{ kg})(4.18 \text{ kJ}/\text{kg}\cdot\text{K})(T_2 - 95) + (111.5 \text{ kg})(0.718 \text{ kJ}/\text{kg}\cdot\text{K})(T_2 - 12) \longrightarrow T_2 = \mathbf{70.2^\circ\text{C}}$$

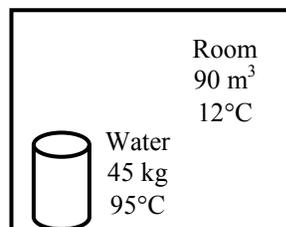

(b) The heat transfer to the air is

$$Q = m_a c_v (T_2 - T_{a1}) = (111.5 \text{ kg})(0.718 \text{ kJ}/\text{kg}\cdot\text{K})(70.2 - 12) = \mathbf{4660 \text{ kJ}}$$

(c) The entropy generation associated with this heat transfer process may be obtained by calculating total entropy change, which is the sum of the entropy changes of water and the air.

$$\Delta S_w = m_w c_w \ln \frac{T_2}{T_{w1}} = (45 \text{ kg})(4.18 \text{ kJ}/\text{kg}\cdot\text{K}) \ln \frac{(70.2 + 273) \text{ K}}{(95 + 273) \text{ K}} = -13.11 \text{ kJ}/\text{K}$$

$$P_2 = \frac{m_a R T_2}{\mathcal{V}} = \frac{(111.5 \text{ kg})(0.287 \text{ kPa}\cdot\text{m}^3/\text{kg}\cdot\text{K})(70.2 + 273 \text{ K})}{(90 \text{ m}^3)} = 122 \text{ kPa}$$

$$\begin{aligned} \Delta S_a &= m_a \left(c_p \ln \frac{T_2}{T_{a1}} - R \ln \frac{P_2}{P_1} \right) \\ &= (111.5 \text{ kg}) \left[(1.005 \text{ kJ}/\text{kg}\cdot\text{K}) \ln \frac{(70.2 + 273) \text{ K}}{(12 + 273) \text{ K}} - (0.287 \text{ kJ}/\text{kg}\cdot\text{K}) \ln \frac{122 \text{ kPa}}{101.3 \text{ kPa}} \right] = 14.88 \text{ kJ}/\text{K} \end{aligned}$$

$$S_{\text{gen}} = \Delta S_{\text{total}} = \Delta S_w + \Delta S_a = -13.11 + 14.88 = \mathbf{1.77 \text{ kJ}/\text{K}}$$

7-105 Air is accelerated in an isentropic nozzle. The maximum velocity at the exit is to be determined.

Assumptions 1 Air is an ideal gas with constant specific heats. **2** The nozzle operates steadily.

Properties The properties of air at room temperature are $c_p = 1.005 \text{ kJ/kg}\cdot\text{K}$, $k = 1.4$ (Table A-2a).

Analysis The exit temperature is determined from ideal gas isentropic relation to be,

$$T_2 = T_1 \left(\frac{P_2}{P_1} \right)^{(k-1)/k} = (400 + 273 \text{ K}) \left(\frac{100 \text{ kPa}}{800 \text{ kPa}} \right)^{0.4/1.4} = 371.5 \text{ K}$$

We take the nozzle as the system, which is a control volume. The energy balance for this steady-flow system can be expressed in the rate form as

$$\underbrace{\dot{E}_{\text{in}} - \dot{E}_{\text{out}}}_{\text{Rate of net energy transfer by heat, work, and mass}} = \underbrace{\Delta \dot{E}_{\text{system}}}_{\text{Rate of change in internal, kinetic, potential, etc. energies}} \stackrel{\neq 0 \text{ (steady)}}{=} 0$$

$$\dot{E}_{\text{in}} = \dot{E}_{\text{out}}$$

$$\dot{m}(h_1 + V_1^2/2) = \dot{m}(h_2 + V_2^2/2)$$

$$0 = h_2 - h_1 + \frac{V_2^2 - 0}{2}$$

$$0 = c_p(T_2 - T_1) + \frac{V_2^2}{2}$$

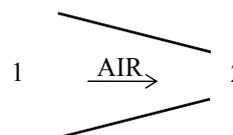

Therefore,

$$V_2 = \sqrt{2c_p(T_2 - T_1)} = \sqrt{2(1.005 \text{ kJ/kg}\cdot\text{K})(673 - 371.5)\text{K} \left(\frac{1000 \text{ m}^2/\text{s}^2}{1 \text{ kJ/kg}} \right)} = \mathbf{778.5 \text{ m/s}}$$

7-106 An ideal gas is compressed in an isentropic compressor. 10% of gas is compressed to 400 kPa and 90% is compressed to 600 kPa. The compression process is to be sketched, and the exit temperatures at the two exits, and the mass flow rate into the compressor are to be determined.

Assumptions 1 The compressor operates steadily. 2 The process is reversible-adiabatic (isentropic)

Properties The properties of ideal gas are given to be $c_p = 1.1$ kJ/kg.K and $c_v = 0.8$ kJ/kg.K.

Analysis (b) The specific heat ratio of the gas is

$$k = \frac{c_p}{c_v} = \frac{1.1}{0.8} = 1.375$$

The exit temperatures are determined from ideal gas isentropic relations to be,

$$T_2 = T_1 \left(\frac{P_2}{P_1} \right)^{(k-1)/k} = (27 + 273 \text{ K}) \left(\frac{400 \text{ kPa}}{100 \text{ kPa}} \right)^{0.375/1.375} = \mathbf{437.8 \text{ K}}$$

$$T_3 = T_1 \left(\frac{P_3}{P_1} \right)^{(k-1)/k} = (27 + 273 \text{ K}) \left(\frac{600 \text{ kPa}}{100 \text{ kPa}} \right)^{0.375/1.375} = \mathbf{489.0 \text{ K}}$$

(c) A mass balance on the control volume gives

$$\dot{m}_1 = \dot{m}_2 + \dot{m}_3$$

where

$$\dot{m}_2 = 0.1\dot{m}_1$$

$$\dot{m}_3 = 0.9\dot{m}_1$$

We take the compressor as the system, which is a control volume. The energy balance for this steady-flow system can be expressed in the rate form as

$$\underbrace{\dot{E}_{in} - \dot{E}_{out}}_{\text{Rate of net energy transfer by heat, work, and mass}} = \underbrace{\Delta \dot{E}_{system}^{\phi 0} \text{ (steady)}}_{\text{Rate of change in internal, kinetic, potential, etc. energies}} = 0$$

$$\dot{E}_{in} = \dot{E}_{out}$$

$$\dot{m}_1 h_1 + \dot{W}_{in} = \dot{m}_2 h_2 + \dot{m}_3 h_3$$

$$\dot{m}_1 c_p T_1 + \dot{W}_{in} = 0.1\dot{m}_1 c_p T_2 + 0.9\dot{m}_1 c_p T_3$$

Solving for the inlet mass flow rate, we obtain

$$\begin{aligned} \dot{m}_1 &= \frac{\dot{W}_{in}}{c_p [0.1(T_2 - T_1) + 0.9(T_3 - T_1)]} \\ &= \frac{32 \text{ kW}}{(1.1 \text{ kJ/kg} \cdot \text{K}) [0.1(437.8 - 300) + 0.9(489.0 - 300)]} \\ &= \mathbf{0.158 \text{ kg/s}} \end{aligned}$$

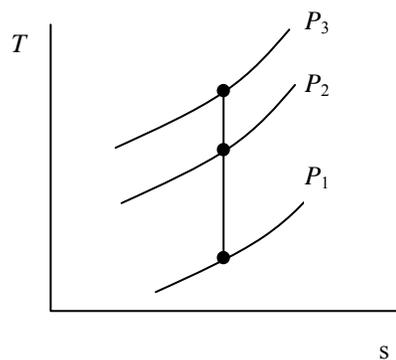
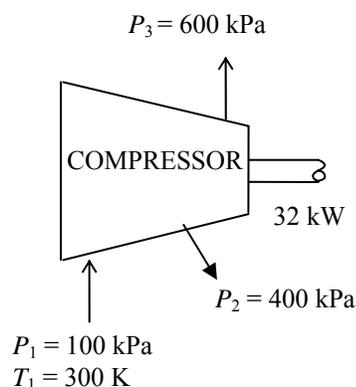

7-107 Air contained in a constant-volume tank is cooled to ambient temperature. The entropy changes of the air and the universe due to this process are to be determined and the process is to be sketched on a T-s diagram.

Assumptions 1 Air is an ideal gas with constant specific heats.

Properties The specific heat of air at room temperature is $c_v = 0.718 \text{ kJ/kg}\cdot\text{K}$ (Table A-2a).

Analysis (a) The entropy change of air is determined from

$$\begin{aligned}\Delta S_{\text{air}} &= mc_v \ln \frac{T_2}{T_1} \\ &= (5 \text{ kg})(0.718 \text{ kJ/kg}\cdot\text{K}) \ln \frac{(27 + 273) \text{ K}}{(327 + 273) \text{ K}} \\ &= \mathbf{-2.488 \text{ kJ/K}}\end{aligned}$$

(b) An energy balance on the system gives

$$\begin{aligned}Q_{\text{out}} &= mc_v(T_2 - T_1) \\ &= (5 \text{ kg})(0.718 \text{ kJ/kg}\cdot\text{K})(327 - 27) \\ &= 1077 \text{ kJ}\end{aligned}$$

The entropy change of the surroundings is

$$\Delta S_{\text{surr}} = \frac{Q_{\text{out}}}{T_{\text{surr}}} = \frac{1077 \text{ kJ}}{300 \text{ K}} = 3.59 \text{ kJ/K}$$

The entropy change of universe due to this process is

$$S_{\text{gen}} = \Delta S_{\text{total}} = \Delta S_{\text{air}} + \Delta S_{\text{surr}} = -2.488 + 3.59 = \mathbf{1.10 \text{ kJ/K}}$$

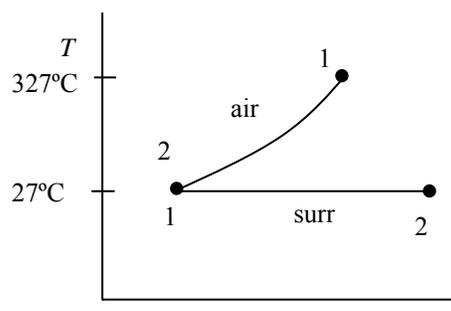
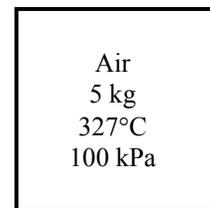

Reversible Steady-Flow Work

7-108C The work associated with steady-flow devices is proportional to the specific volume of the gas. Cooling a gas during compression will reduce its specific volume, and thus the power consumed by the compressor.

7-109C Cooling the steam as it expands in a turbine will reduce its specific volume, and thus the work output of the turbine. Therefore, this is not a good proposal.

7-110C We would not support this proposal since the steady-flow work input to the pump is proportional to the specific volume of the liquid, and cooling will not affect the specific volume of a liquid significantly.

7-111 Air is compressed isothermally in a reversible steady-flow device. The work required is to be determined.

Assumptions **1** This is a steady-flow process since there is no change with time. **2** There is no heat transfer associated with the process. **3** Kinetic and potential energy changes are negligible. **4** Air is an ideal gas with constant specific heats.

Properties The gas constant of air is $R = 0.06855 \text{ Btu/lbm}\cdot\text{R}$ (Table A-1E).

Analysis Substituting the ideal gas equation of state into the reversible steady-flow work expression gives

$$\begin{aligned} w_{\text{in}} &= \int_1^2 v dP = RT \int_1^2 \frac{dP}{P} = RT \ln \frac{P_2}{P_1} \\ &= (0.06855 \text{ Btu/lbm}\cdot\text{R})(75 + 460 \text{ K}) \ln \left(\frac{120 \text{ psia}}{16 \text{ psia}} \right) \\ &= \mathbf{73.9 \text{ Btu/lbm}} \end{aligned}$$

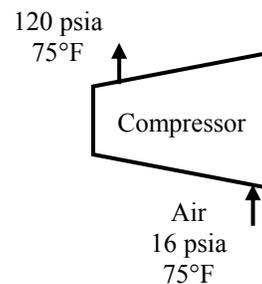

7-112 Saturated water vapor is compressed in a reversible steady-flow device. The work required is to be determined.

Assumptions 1 This is a steady-flow process since there is no change with time. **2** There is no heat transfer associated with the process. **3** Kinetic and potential energy changes are negligible.

Analysis The properties of water at the inlet state are

$$\left. \begin{array}{l} T_1 = 150^\circ\text{C} \\ x_1 = 1 \end{array} \right\} \begin{array}{l} P_1 = 476.16 \text{ kPa} \\ \nu_1 = 0.39248 \text{ m}^3/\text{kg} \end{array} \quad (\text{Table A-4})$$

Noting that the specific volume remains constant, the reversible steady-flow work expression gives

$$\begin{aligned} w_{\text{in}} &= \int_1^2 \nu dP = \nu_1 (P_2 - P_1) \\ &= (0.39248 \text{ m}^3/\text{kg})(1000 - 476.16) \text{ kPa} \left(\frac{1 \text{ kJ}}{1 \text{ kPa} \cdot \text{m}^3} \right) \\ &= \mathbf{205.6 \text{ kJ/kg}} \end{aligned}$$

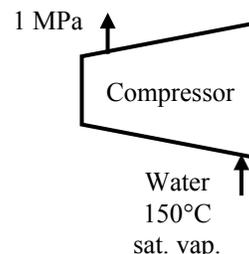

7-113 The work produced for the process 1-3 shown in the figure is to be determined.

Assumptions Kinetic and potential energy changes are negligible.

Analysis The work integral represents the area to the left of the reversible process line. Then,

$$\begin{aligned} w_{\text{in},1-3} &= \int_1^2 \nu dP + \int_2^3 \nu dP \\ &= \frac{\nu_1 + \nu_2}{2} (P_2 - P_1) + \nu_2 (P_3 - P_2) \\ &= \frac{(0.5 + 1.0) \text{ m}^3/\text{kg}}{2} (100 - 500) \text{ kPa} + (1.0 \text{ m}^3/\text{kg})(400 - 100) \text{ kPa} \\ &= \mathbf{0 \text{ kJ/kg}} \end{aligned}$$

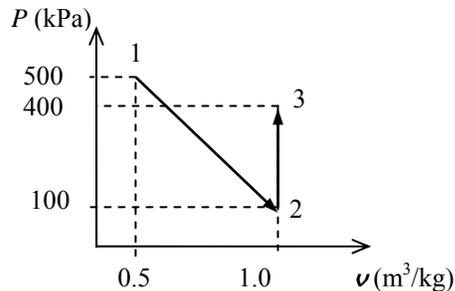

7-114 The work produced for the process 1-2 shown in the figure is to be determined.

Assumptions Kinetic and potential energy changes are negligible.

Analysis The work integral represents the area to the left of the reversible process line. Then,

$$\begin{aligned} w_{\text{in},1-2} &= \int_1^2 \boldsymbol{\nu} dP \\ &= \frac{\boldsymbol{\nu}_1 + \boldsymbol{\nu}_2}{2} (P_2 - P_1) \\ &= \frac{(0.1 + 1.7) \text{ft}^3/\text{lbm}}{2} (500 - 100) \text{psia} \left(\frac{1 \text{ Btu}}{5.404 \text{ psia} \cdot \text{ft}^3} \right) \\ &= \mathbf{66.6 \text{ Btu/lbm}} \end{aligned}$$

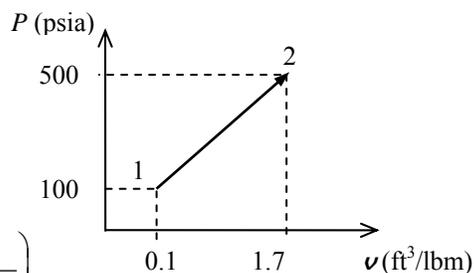

7-115 Liquid water is to be pumped by a 25-kW pump at a specified rate. The highest pressure the water can be pumped to is to be determined.

Assumptions 1 Liquid water is an incompressible substance. **2** Kinetic and potential energy changes are negligible. **3** The process is assumed to be reversible since we will determine the limiting case.

Properties The specific volume of liquid water is given to be $\boldsymbol{\nu}_1 = 0.001 \text{ m}^3/\text{kg}$.

Analysis The highest pressure the liquid can have at the pump exit can be determined from the reversible steady-flow work relation for a liquid,

$$\dot{W}_{\text{in}} = \dot{m} \left(\int_1^2 \boldsymbol{\nu} dP + \Delta ke^{\text{e}} + \Delta pe^{\text{e}} \right) = \dot{m} \boldsymbol{\nu}_1 (P_2 - P_1)$$

Thus,

$$25 \text{ kJ/s} = (5 \text{ kg/s})(0.001 \text{ m}^3/\text{kg})(P_2 - 100) \text{ kPa} \left(\frac{1 \text{ kJ}}{1 \text{ kPa} \cdot \text{m}^3} \right)$$

It yields

$$P_2 = \mathbf{5100 \text{ kPa}}$$

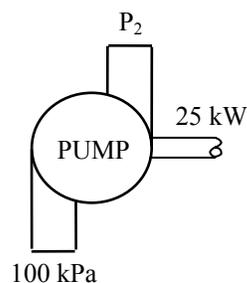

7-116 A steam power plant operates between the pressure limits of 10 MPa and 20 kPa. The ratio of the turbine work to the pump work is to be determined.

Assumptions 1 Liquid water is an incompressible substance. **2** Kinetic and potential energy changes are negligible. **3** The process is reversible. **4** The pump and the turbine are adiabatic.

Properties The specific volume of saturated liquid water at 20 kPa is $\nu_1 = \nu_f @ 20 \text{ kPa} = 0.001017 \text{ m}^3/\text{kg}$ (Table A-5).

Analysis Both the compression and expansion processes are reversible and adiabatic, and thus isentropic, $s_1 = s_2$ and $s_3 = s_4$. Then the properties of the steam are

$$P_4 = 20 \text{ kPa} \left. \begin{array}{l} h_4 = h_g @ 20 \text{ kPa} = 2608.9 \text{ kJ/kg} \\ \text{sat. vapor} \quad s_4 = s_g @ 20 \text{ kPa} = 7.9073 \text{ kJ/kg} \cdot \text{K} \end{array} \right\}$$

$$P_3 = 10 \text{ MPa} \left. \begin{array}{l} h_3 = 4707.2 \text{ kJ/kg} \\ s_3 = s_4 \end{array} \right\}$$

Also, $\nu_1 = \nu_f @ 20 \text{ kPa} = 0.001017 \text{ m}^3/\text{kg}$.

The work output to this isentropic turbine is determined from the steady-flow energy balance to be

$$\underbrace{\dot{E}_{\text{in}} - \dot{E}_{\text{out}}}_{\text{Rate of net energy transfer by heat, work, and mass}} = \underbrace{\Delta \dot{E}_{\text{system}}^{\phi 0}}_{\text{Rate of change in internal, kinetic, potential, etc. energies (steady)}} = 0$$

$$\dot{E}_{\text{in}} = \dot{E}_{\text{out}}$$

$$\dot{m}h_3 = \dot{m}h_4 + \dot{W}_{\text{out}}$$

$$\dot{W}_{\text{out}} = \dot{m}(h_3 - h_4)$$

Substituting,

$$w_{\text{turb,out}} = h_3 - h_4 = 4707.2 - 2608.9 = 2098.3 \text{ kJ/kg}$$

The pump work input is determined from the steady-flow work relation to be

$$\begin{aligned} w_{\text{pump,in}} &= \int_1^2 \nu dP + \Delta ke^{\phi 0} + \Delta pe^{\phi 0} = \nu_1(P_2 - P_1) \\ &= (0.001017 \text{ m}^3/\text{kg})(10,000 - 20) \text{ kPa} \left(\frac{1 \text{ kJ}}{1 \text{ kPa} \cdot \text{m}^3} \right) \\ &= 10.15 \text{ kJ/kg} \end{aligned}$$

Thus,

$$\frac{w_{\text{turb,out}}}{w_{\text{pump,in}}} = \frac{2098.3}{10.15} = \mathbf{206.7}$$

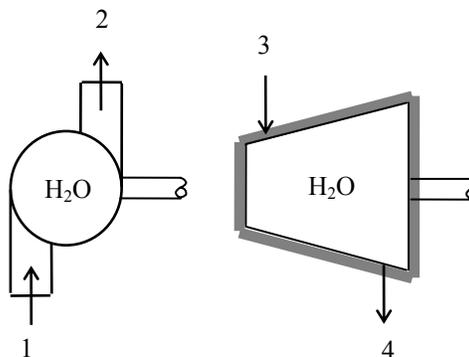

7-117 EES Problem 7-116 is reconsidered. The effect of the quality of the steam at the turbine exit on the net work output is to be investigated as the quality is varied from 0.5 to 1.0, and the net work output is to be plotted as a function of this quality.

Analysis The problem is solved using EES, and the results are tabulated and plotted below.

"System: control volume for the pump and turbine"

"Property relation: Steam functions"

"Process: For Pump and Turbine: Steady state, steady flow, adiabatic, reversible or isentropic"

"Since we don't know the mass, we write the conservation of energy per unit mass."

"Conservation of mass: $m_{\text{dot}}[1] = m_{\text{dot}}[2]$ "

"Knowns:"

WorkFluid\$ = 'Steam_IAPWS'

P[1] = 20 [kPa]

x[1] = 0

P[2] = 10000 [kPa]

x[4] = 1.0

"Pump Analysis:"

T[1]=temperature(WorkFluid\$,P=P[1],x=0)

v[1]=volume(workFluid\$,P=P[1],x=0)

h[1]=enthalpy(WorkFluid\$,P=P[1],x=0)

s[1]=entropy(WorkFluid\$,P=P[1],x=0)

s[2] = s[1]

h[2]=enthalpy(WorkFluid\$,P=P[2],s=s[2])

T[2]=temperature(WorkFluid\$,P=P[2],s=s[2])

"The Volume function has the same form for an ideal gas as for a real fluid."

v[2]=volume(WorkFluid\$,T=T[2],p=P[2])

"Conservation of Energy - SSSF energy balance for pump"

" -- neglect the change in potential energy, no heat transfer:"

$h[1] + W_{\text{pump}} = h[2]$

"Also the work of pump can be obtained from the incompressible fluid, steady-flow result:"

$W_{\text{pump_incomp}} = v[1] * (P[2] - P[1])$

"Conservation of Energy - SSSF energy balance for turbine -- neglecting the change in potential energy, no heat transfer:"

P[4] = P[1]

P[3] = P[2]

h[4]=enthalpy(WorkFluid\$,P=P[4],x=x[4])

s[4]=entropy(WorkFluid\$,P=P[4],x=x[4])

T[4]=temperature(WorkFluid\$,P=P[4],x=x[4])

s[3] = s[4]

h[3]=enthalpy(WorkFluid\$,P=P[3],s=s[3])

T[3]=temperature(WorkFluid\$,P=P[3],s=s[3])

$h[3] = h[4] + W_{\text{turb}}$

$W_{\text{net_out}} = W_{\text{turb}} - W_{\text{pump}}$

$W_{\text{net,out}}$ [kJ/kg]	W_{pump} [kJ/kg]	$W_{\text{pump,incomp}}$ [kJ/kg]	W_{turb} [kJ/kg]	x_4
557.1	10.13	10.15	567.3	0.5
734.7	10.13	10.15	744.8	0.6
913.6	10.13	10.15	923.7	0.7
1146	10.13	10.15	1156	0.8
1516	10.13	10.15	1527	0.9
2088	10.13	10.15	2098	1

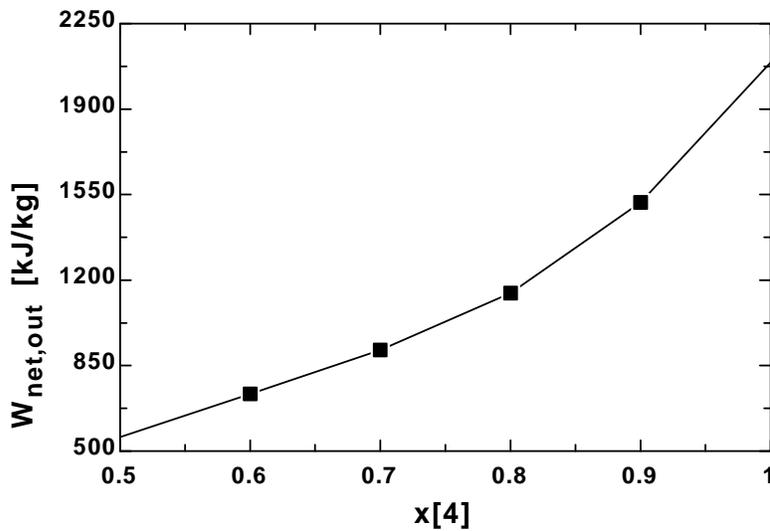
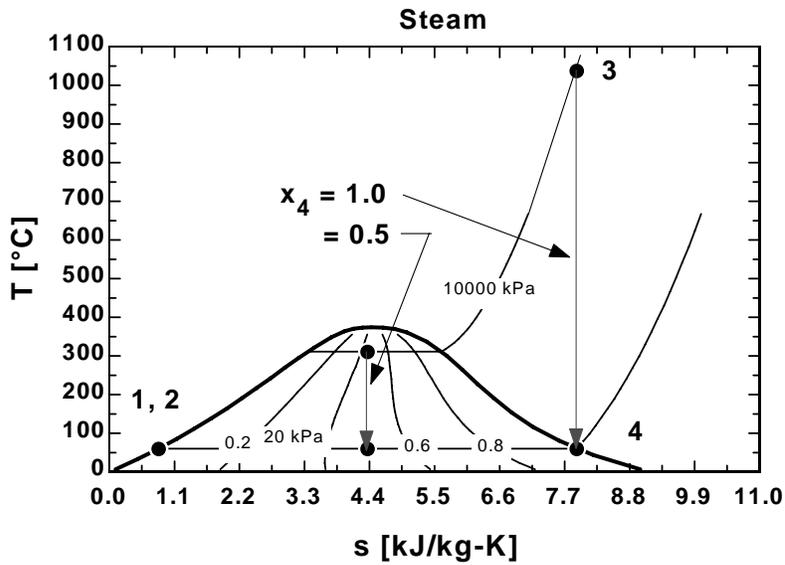

7-118 Liquid water is pumped by a 70-kW pump to a specified pressure at a specified level. The highest possible mass flow rate of water is to be determined.

Assumptions **1** Liquid water is an incompressible substance. **2** Kinetic energy changes are negligible, but potential energy changes may be significant. **3** The process is assumed to be reversible since we will determine the limiting case.

Properties The specific volume of liquid water is given to be $\nu_1 = 0.001 \text{ m}^3/\text{kg}$.

Analysis The highest mass flow rate will be realized when the entire process is reversible. Thus it is determined from the reversible steady-flow work relation for a liquid,

$$\dot{W}_{\text{in}} = \dot{m} \left(\int_1^2 \nu dP + \Delta ke^{\text{avg}} + \Delta pe \right) = \dot{m} \{ \nu(P_2 - P_1) + g(z_2 - z_1) \}$$

Thus,

$$7 \text{ kJ/s} = \dot{m} \left\{ (0.001 \text{ m}^3/\text{kg})(5000 - 120) \text{ kPa} \left(\frac{1 \text{ kJ}}{1 \text{ kPa} \cdot \text{m}^3} \right) + (9.8 \text{ m/s}^2)(10 \text{ m}) \left(\frac{1 \text{ kJ/kg}}{1000 \text{ m}^2/\text{s}^2} \right) \right\}$$

It yields

$$\dot{m} = \mathbf{1.41 \text{ kg/s}}$$

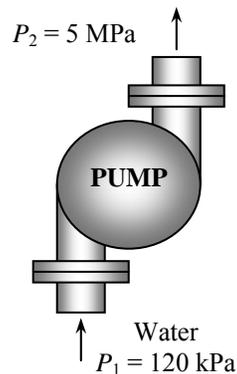

7-119E Helium gas is compressed from a specified state to a specified pressure at a specified rate. The power input to the compressor is to be determined for the cases of isentropic, polytropic, isothermal, and two-stage compression.

Assumptions **1** Helium is an ideal gas with constant specific heats. **2** The process is reversible. **3** Kinetic and potential energy changes are negligible.

Properties The gas constant of helium is $R = 2.6805 \text{ psia} \cdot \text{ft}^3/\text{lbm} \cdot \text{R}$
 $= 0.4961 \text{ Btu}/\text{lbm} \cdot \text{R}$. The specific heat ratio of helium is $k = 1.667$
 (Table A-2E).

Analysis The mass flow rate of helium is

$$\dot{m} = \frac{P_1 \dot{V}_1}{RT_1} = \frac{(14 \text{ psia})(5 \text{ ft}^3/\text{s})}{(2.6805 \text{ psia} \cdot \text{ft}^3/\text{lbm} \cdot \text{R})(530 \text{ R})} = 0.0493 \text{ lbm/s}$$

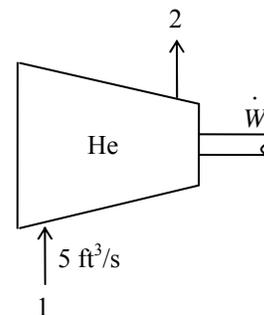

(a) Isentropic compression with $k = 1.667$:

$$\begin{aligned} \dot{W}_{\text{comp, in}} &= \dot{m} \frac{kRT_1}{k-1} \left\{ \left(\frac{P_2}{P_1} \right)^{(k-1)/k} - 1 \right\} \\ &= (0.0493 \text{ lbm/s}) \frac{(1.667)(0.4961 \text{ Btu}/\text{lbm} \cdot \text{R})(530 \text{ R})}{1.667 - 1} \left\{ \left(\frac{120 \text{ psia}}{14 \text{ psia}} \right)^{0.667/1.667} - 1 \right\} \\ &= 44.11 \text{ Btu/s} \\ &= \mathbf{62.4 \text{ hp}} \quad \text{since } 1 \text{ hp} = 0.7068 \text{ Btu/s} \end{aligned}$$

(b) Polytropic compression with $n = 1.2$:

$$\begin{aligned} \dot{W}_{\text{comp, in}} &= \dot{m} \frac{nRT_1}{n-1} \left\{ \left(\frac{P_2}{P_1} \right)^{(n-1)/n} - 1 \right\} \\ &= (0.0493 \text{ lbm/s}) \frac{(1.2)(0.4961 \text{ Btu}/\text{lbm} \cdot \text{R})(530 \text{ R})}{1.2 - 1} \left\{ \left(\frac{120 \text{ psia}}{14 \text{ psia}} \right)^{0.2/1.2} - 1 \right\} \\ &= 33.47 \text{ Btu/s} \\ &= \mathbf{47.3 \text{ hp}} \quad \text{since } 1 \text{ hp} = 0.7068 \text{ Btu/s} \end{aligned}$$

(c) Isothermal compression:

$$\dot{W}_{\text{comp, in}} = \dot{m}RT \ln \frac{P_2}{P_1} = (0.0493 \text{ lbm/s})(0.4961 \text{ Btu}/\text{lbm} \cdot \text{R})(530 \text{ R}) \ln \frac{120 \text{ psia}}{14 \text{ psia}} = 27.83 \text{ Btu/s} = \mathbf{39.4 \text{ hp}}$$

(d) Ideal two-stage compression with intercooling ($n = 1.2$): In this case, the pressure ratio across each stage is the same, and its value is determined from

$$P_x = \sqrt{P_1 P_2} = \sqrt{(14 \text{ psia})(120 \text{ psia})} = 41.0 \text{ psia}$$

The compressor work across each stage is also the same, thus total compressor work is twice the compression work for a single stage:

$$\begin{aligned} \dot{W}_{\text{comp, in}} &= 2\dot{m}w_{\text{comp, I}} = 2\dot{m} \frac{nRT_1}{n-1} \left\{ \left(\frac{P_x}{P_1} \right)^{(n-1)/n} - 1 \right\} \\ &= 2(0.0493 \text{ lbm/s}) \frac{(1.2)(0.4961 \text{ Btu}/\text{lbm} \cdot \text{R})(530 \text{ R})}{1.2 - 1} \left\{ \left(\frac{41 \text{ psia}}{14 \text{ psia}} \right)^{0.2/1.2} - 1 \right\} \\ &= 30.52 \text{ Btu/s} \\ &= \mathbf{43.2 \text{ hp}} \quad \text{since } 1 \text{ hp} = 0.7068 \text{ Btu/s} \end{aligned}$$

7-120E EES Problem 7-119E is reconsidered. The work of compression and entropy change of the helium is to be evaluated and plotted as functions of the polytropic exponent as it varies from 1 to 1.667.

Analysis The problem is solved using EES, and the results are tabulated and plotted below.

```
Procedure FuncPoly(m_dot,k, R,
T1,P2,P1,n:W_dot_comp_polytropic,W_dot_comp_2stagePoly,Q_dot_Out_polytropic,Q_dot_Out_2stagePoly)
```

```
If n =1 then
```

```
T2=T1
```

```
W_dot_comp_polytropic= m_dot*R*(T1+460)*ln(P2/P1)*convert(Btu/s,hp) "[hp]"
```

```
W_dot_comp_2stagePoly = W_dot_comp_polytropic "[hp]"
```

```
Q_dot_Out_polytropic=W_dot_comp_polytropic*convert(hp,Btu/s) "[Btu/s]"
```

```
Q_dot_Out_2stagePoly = Q_dot_Out_polytropic*convert(hp,Btu/s) "[Btu/s]"
```

```
Else
```

```
C_P = k*R/(k-1) "[Btu/lbm-R]"
```

```
T2=(T1+460)*((P2/P1)^((n+1)/n)-460)"[F]"
```

```
W_dot_comp_polytropic = m_dot*n*R*(T1+460)/(n-1)*((P2/P1)^((n-1)/n) -
```

```
1)*convert(Btu/s,hp)"[hp]"
```

```
Q_dot_Out_polytropic=W_dot_comp_polytropic*convert(hp,Btu/s)+m_dot*C_P*(T1-T2)"[Btu/s]"
```

```
Px=(P1*P2)^0.5
```

```
T2x=(T1+460)*((Px/P1)^((n+1)/n)-460)"[F]"
```

```
W_dot_comp_2stagePoly = 2*m_dot*n*R*(T1+460)/(n-1)*((Px/P1)^((n-1)/n) -
```

```
1)*convert(Btu/s,hp)"[hp]"
```

```
Q_dot_Out_2stagePoly=W_dot_comp_2stagePoly*convert(hp,Btu/s)+2*m_dot*C_P*(T1-
T2x)"[Btu/s]"
```

```
endif
```

```
END
```

```
R=0.4961[Btu/lbm-R]
```

```
k=1.667
```

```
n=1.2
```

```
P1=14 [psia]
```

```
T1=70 [F]
```

```
P2=120 [psia]
```

```
V_dot = 5 [ft^3/s]
```

```
P1*V_dot=m_dot*R*(T1+460)*convert(Btu,psia-ft^3)
```

```
W_dot_comp_isentropic = m_dot*k*R*(T1+460)/(k-1)*((P2/P1)^((k-1)/k) -
```

```
1)*convert(Btu/s,hp)"[hp]"
```

```
Q_dot_Out_isentropic = 0"[Btu/s]"
```

```
Call FuncPoly(m_dot,k, R,
```

```
T1,P2,P1,n:W_dot_comp_polytropic,W_dot_comp_2stagePoly,Q_dot_Out_polytropic,Q_dot_Out_2stagePoly)
```

```
W_dot_comp_isothermal= m_dot*R*(T1+460)*ln(P2/P1)*convert(Btu/s,hp)"[hp]"
```

```
Q_dot_Out_isothermal = W_dot_comp_isothermal*convert(hp,Btu/s)"[Btu/s]"
```

n	$W_{\text{comp2StagePoly}}$ [hp]	$W_{\text{compisentropic}}$ [hp]	$W_{\text{compisothermal}}$ [hp]	$W_{\text{comppolytropic}}$ [hp]
1	39.37	62.4	39.37	39.37
1.1	41.36	62.4	39.37	43.48
1.2	43.12	62.4	39.37	47.35
1.3	44.68	62.4	39.37	50.97
1.4	46.09	62.4	39.37	54.36
1.5	47.35	62.4	39.37	57.54
1.667	49.19	62.4	39.37	62.4

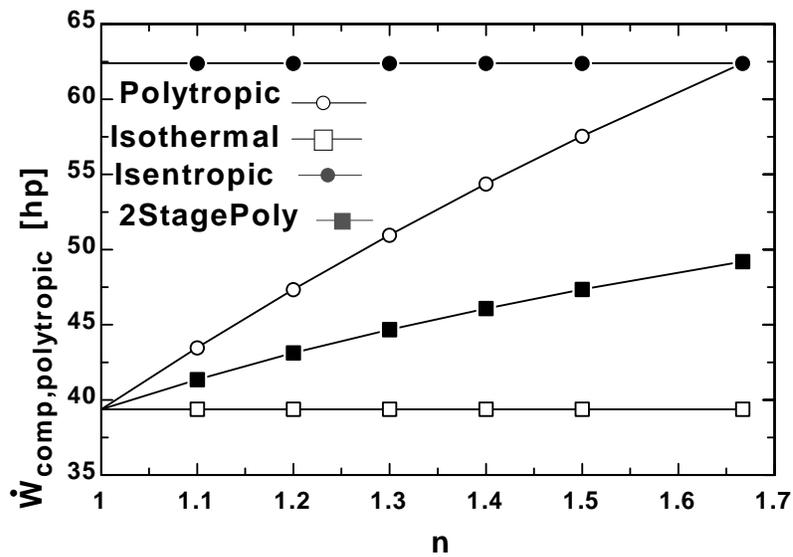

7-121 Water mist is to be sprayed into the air stream in the compressor to cool the air as the water evaporates and to reduce the compression power. The reduction in the exit temperature of the compressed air and the compressor power saved are to be determined.

Assumptions **1** Air is an ideal gas with variable specific heats. **2** The process is reversible. **3** Kinetic and potential energy changes are negligible. **3** Air is compressed isentropically. **4** Water vaporizes completely before leaving the compressor. **4** Air properties can be used for the air-vapor mixture.

Properties The gas constant of air is $R = 0.287 \text{ kJ/kg}\cdot\text{K}$ (Table A-1). The specific heat ratio of air is $k = 1.4$. The inlet enthalpies of water and air are (Tables A-4 and A-17)

$$h_{w1} = h_{f@20^\circ\text{C}} = 83.29 \text{ kJ/kg}, h_{fg@20^\circ\text{C}} = 2453.9 \text{ kJ/kg} \text{ and } h_{a1} = h_{@300\text{K}} = 300.19 \text{ kJ/kg}$$

Analysis In the case of isentropic operation (thus no cooling or water spray), the exit temperature and the power input to the compressor are

$$\frac{T_2}{T_1} = \left(\frac{P_2}{P_1}\right)^{(k-1)/k} \rightarrow T_2 = (300 \text{ K}) \left(\frac{1200 \text{ kPa}}{100 \text{ kPa}}\right)^{(1.4-1)/1.4} = 610.2 \text{ K}$$

$$\begin{aligned} \dot{W}_{\text{comp, in}} &= \dot{m} \frac{kRT_1}{k-1} \left\{ \left(\frac{P_2}{P_1}\right)^{(k-1)/k} - 1 \right\} \\ &= (2.1 \text{ kg/s}) \frac{(1.4)(0.287 \text{ kJ/kg}\cdot\text{K})(300 \text{ K})}{1.4-1} \left\{ (1200 \text{ kPa}/100 \text{ kPa})^{0.4/1.4} - 1 \right\} = 654.3 \text{ kW} \end{aligned}$$

When water is sprayed, we first need to check the accuracy of the assumption that the water vaporizes completely in the compressor. In the limiting case, the compression will be isothermal at the compressor inlet temperature, and the water will be a saturated vapor. To avoid the complexity of dealing with two fluid streams and a gas mixture, we disregard water in the air stream (other than the mass flow rate), and assume air is cooled by an amount equal to the enthalpy change of water.

The rate of heat absorption of water as it evaporates at the inlet temperature completely is

$$\dot{Q}_{\text{cooling, max}} = \dot{m}_w h_{fg@20^\circ\text{C}} = (0.2 \text{ kg/s})(2453.9 \text{ kJ/kg}) = 490.8 \text{ kW}$$

The minimum power input to the compressor is

$$\dot{W}_{\text{comp, in, min}} = \dot{m}RT \ln \frac{P_2}{P_1} = (2.1 \text{ kg/s})(0.287 \text{ kJ/kg}\cdot\text{K})(300 \text{ K}) \ln \left(\frac{1200 \text{ kPa}}{100 \text{ kPa}}\right) = 449.3 \text{ kW}$$

This corresponds to maximum cooling from the air since, at constant temperature, $\Delta h = 0$ and thus $\dot{Q}_{\text{out}} = \dot{W}_{\text{in}} = 449.3 \text{ kW}$, which is close to 490.8 kW. Therefore, the assumption that all the water vaporizes is approximately valid. Then the reduction in required power input due to water spray becomes

$$\Delta \dot{W}_{\text{comp, in}} = \dot{W}_{\text{comp, isentropic}} - \dot{W}_{\text{comp, isothermal}} = 654.3 - 449.3 = \mathbf{205 \text{ kW}}$$

Discussion (can be ignored): At constant temperature, $\Delta h = 0$ and thus $\dot{Q}_{\text{out}} = \dot{W}_{\text{in}} = 449.3 \text{ kW}$ corresponds to maximum cooling from the air, which is less than 490.8 kW. Therefore, the assumption that all the water vaporizes is only roughly valid. As an alternative, we can assume the compression process to be polytropic and the water to be a saturated vapor at the compressor exit temperature, and disregard the remaining liquid. But in this case there is not a unique solution, and we will have to select either the amount of water or the exit temperature or the polytropic exponent to obtain a solution. Of course we can also tabulate the results for different cases, and then make a selection.

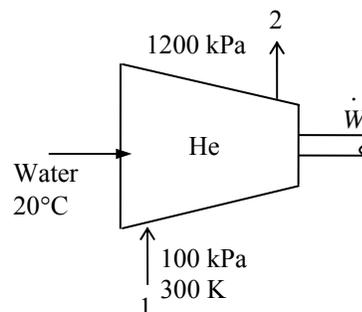

Sample Analysis: We take the compressor exit temperature to be $T_2 = 200^\circ\text{C} = 473\text{ K}$. Then,

$$h_{w2} = h_{g@200^\circ\text{C}} = 2792.0\text{ kJ/kg} \text{ and } h_{a2} = h_{@473\text{ K}} = 475.3\text{ kJ/kg}$$

Then,

$$\frac{T_2}{T_1} = \left(\frac{P_2}{P_1}\right)^{(n-1)/n} \rightarrow \frac{473\text{ K}}{300\text{ K}} = \left(\frac{1200\text{ kPa}}{100\text{ kPa}}\right)^{(n-1)/n} \rightarrow n = 1.224$$

$$\begin{aligned} \dot{W}_{\text{comp},\text{in}} &= \dot{m} \frac{nRT_1}{n-1} \left\{ \left(\frac{P_2}{P_1}\right)^{(n-1)/n} - 1 \right\} = \dot{m} \frac{nR}{n-1} (T_2 - T_1) \\ &= (2.1\text{ kg/s}) \frac{(1.224)(0.287\text{ kJ/kg}\cdot\text{K})}{1.224-1} (473-300)\text{K} = 570\text{ kW} \end{aligned}$$

Energy balance:

$$\begin{aligned} \dot{W}_{\text{comp},\text{in}} - \dot{Q}_{\text{out}} &= \dot{m}(h_2 - h_1) \rightarrow \dot{Q}_{\text{out}} = \dot{W}_{\text{comp},\text{in}} - \dot{m}(h_2 - h_1) \\ &= 569.7\text{ kW} - (2.1\text{ kg/s})(475.3 - 300.19) = 202.0\text{ kW} \end{aligned}$$

Noting that this heat is absorbed by water, the rate at which water evaporates in the compressor becomes

$$\dot{Q}_{\text{out},\text{air}} = \dot{Q}_{\text{in},\text{water}} = \dot{m}_w(h_{w2} - h_{w1}) \longrightarrow \dot{m}_w = \frac{\dot{Q}_{\text{in},\text{water}}}{h_{w2} - h_{w1}} = \frac{202.0\text{ kJ/s}}{(2792.0 - 83.29)\text{ kJ/kg}} = 0.0746\text{ kg/s}$$

Then the reductions in the exit temperature and compressor power input become

$$\begin{aligned} \Delta T_2 &= T_{2,\text{isentropic}} - T_{2,\text{water cooled}} = 610.2 - 473 = \mathbf{137.2^\circ\text{C}} \\ \Delta \dot{W}_{\text{comp},\text{in}} &= \dot{W}_{\text{comp},\text{isentropic}} - \dot{W}_{\text{comp},\text{water cooled}} = 654.3 - 570 = \mathbf{84.3\text{ kW}} \end{aligned}$$

Note that selecting a different compressor exit temperature T_2 will result in different values.

7-122 A water-injected compressor is used in a gas turbine power plant. It is claimed that the power output of a gas turbine will increase when water is injected into the compressor because of the increase in the mass flow rate of the gas (air + water vapor) through the turbine. This, however, is **not necessarily right** since the compressed air in this case enters the combustor at a low temperature, and thus it absorbs much more heat. In fact, the cooling effect will most likely dominate and cause the cyclic efficiency to drop.

Isentropic Efficiencies of Steady-Flow Devices

7-123C The ideal process for all three devices is the reversible adiabatic (i.e., isentropic) process. The adiabatic efficiencies of these devices are defined as

$$\eta_T = \frac{\text{actual work output}}{\text{isentropic work output}}, \quad \eta_C = \frac{\text{isentropic work input}}{\text{actual work input}}, \quad \text{and} \quad \eta_N = \frac{\text{actual exit kinetic energy}}{\text{isentropic exit kinetic energy}}$$

7-124C No, because the isentropic process is not the model or ideal process for compressors that are cooled intentionally.

7-125C Yes. Because the entropy of the fluid must increase during an actual adiabatic process as a result of irreversibilities. Therefore, the actual exit state has to be on the right-hand side of the isentropic exit state

7-126 Saturated steam is compressed in an adiabatic process with an isentropic efficiency of 0.90. The work required is to be determined.

Assumptions **1** Kinetic and potential energy changes are negligible. **2** The device is adiabatic and thus heat transfer is negligible.

Analysis We take the steam as the system. This is a closed system since no mass enters or leaves. The energy balance for this stationary closed system can be expressed as

$$\underbrace{E_{\text{in}} - E_{\text{out}}}_{\substack{\text{Net energy transfer} \\ \text{by heat, work, and mass}}} = \underbrace{\Delta E_{\text{system}}}_{\substack{\text{Change in internal, kinetic,} \\ \text{potential, etc. energies}}}$$

$$W_{\text{in}} = \Delta U = m(u_2 - u_1)$$

From the steam tables (Tables A-5 and A-6),

$$P_1 = 100 \text{ kPa} \left\{ \begin{array}{l} u_1 = u_{g@100 \text{ kPa}} = 2505.6 \text{ kJ/kg} \\ s_1 = s_{g@100 \text{ kPa}} = 7.3589 \text{ kJ/kg} \cdot \text{K} \end{array} \right.$$

$$P_2 = 1 \text{ MPa} \left\{ \begin{array}{l} u_{2s} = 2903.0 \text{ kJ/kg} \\ s_{2s} = s_1 \end{array} \right.$$

The work input during the isentropic process is

$$W_{s,\text{in}} = m(u_{2s} - u_1) = (100 \text{ kg})(2903.0 - 2505.6) \text{ kJ/kg} = 39,740 \text{ kJ}$$

The actual work input is then

$$W_{a,\text{in}} = \frac{W_{s,\text{in}}}{\eta_C} = \frac{39,740 \text{ kJ}}{0.90} = \mathbf{44,160 \text{ kJ}}$$

7-127E R-134a is expanded in an adiabatic process with an isentropic efficiency of 0.95. The final volume is to be determined.

Assumptions 1 Kinetic and potential energy changes are negligible. **2** The device is adiabatic and thus heat transfer is negligible.

Analysis We take the R-134a as the system. This is a closed system since no mass enters or leaves. The energy balance for this stationary closed system can be expressed as

$$\underbrace{E_{\text{in}} - E_{\text{out}}}_{\substack{\text{Net energy transfer} \\ \text{by heat, work, and mass}}} = \underbrace{\Delta E_{\text{system}}}_{\substack{\text{Change in internal, kinetic,} \\ \text{potential, etc. energies}}} \\ -W_{\text{out}} = \Delta U = m(u_2 - u_1)$$

From the R-134a tables (Tables A-11E through A-13E),

$$\left. \begin{array}{l} P_1 = 120 \text{ psia} \\ T_1 = 100^\circ\text{F} \end{array} \right\} \begin{array}{l} u_1 = 108.48 \text{ Btu/lbm} \\ s_1 = 0.22362 \text{ Btu/lbm} \cdot \text{R} \end{array}$$

$$\left. \begin{array}{l} P_2 = 20 \text{ psia} \\ s_{2s} = s_1 \end{array} \right\} \begin{array}{l} x_{2s} = \frac{s_{2s} - s_f}{s_{fg}} = \frac{0.22362 - 0.02605}{0.19962} = 0.9897 \\ u_{2s} = u_f + x_{2s}u_{fg} = 11.401 + (0.9897)(82.898) = 93.445 \text{ Btu/lbm} \end{array}$$

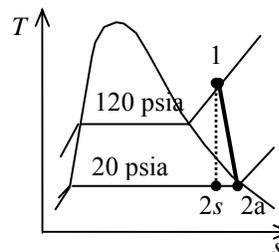

The actual work input is

$$w_{a,\text{out}} = \eta_T w_{s,\text{out}} = \eta_T (u_1 - u_{2s}) = (0.95)(108.48 - 93.448) \text{ Btu/lbm} = 14.28 \text{ Btu/lbm}$$

The actual internal energy at the end of the expansion process is

$$w_{a,\text{out}} = (u_1 - u_{2a}) \longrightarrow u_{2a} = u_1 - w_{a,\text{out}} = 108.48 - 14.28 = 94.20 \text{ Btu/lbm}$$

The specific volume at the final state is (Table A-12E)

$$\left. \begin{array}{l} P_2 = 20 \text{ psia} \\ u_{2a} = 94.20 \text{ Btu/lbm} \end{array} \right\} \begin{array}{l} x_2 = \frac{u_{2a} - u_f}{u_{fg}} = \frac{94.20 - 11.401}{82.898} = 0.9988 \\ v_2 = v_f + x_2 v_{fg} = 0.01182 + (0.9988)(2.2772 - 0.01182) = 2.2745 \text{ ft}^3/\text{lbm} \end{array}$$

The final volume is then

$$V_2 = m v_2 = (10 \text{ lbm})(2.2745 \text{ ft}^3/\text{lbm}) = \mathbf{22.75 \text{ ft}^3}$$

7-128 Steam is expanded in an adiabatic turbine with an isentropic efficiency of 0.92. The power output of the turbine is to be determined.

Assumptions 1 This is a steady-flow process since there is no change with time. **2** Kinetic and potential energy changes are negligible. **3** The device is adiabatic and thus heat transfer is negligible.

Analysis There is only one inlet and one exit, and thus $\dot{m}_1 = \dot{m}_2 = \dot{m}$. We take the actual turbine as the system, which is a control volume since mass crosses the boundary. The energy balance for this steady-flow system can be expressed in the rate form as

$$\underbrace{\dot{E}_{\text{in}} - \dot{E}_{\text{out}}}_{\substack{\text{Rate of net energy transfer} \\ \text{by heat, work, and mass}}} = \underbrace{\Delta \dot{E}_{\text{system}}}_{\substack{\text{Rate of change in internal, kinetic,} \\ \text{potential, etc. energies}}} \overset{\phi^0 \text{ (steady)}}{=} 0$$

$$\dot{E}_{\text{in}} = \dot{E}_{\text{out}}$$

$$\dot{m}h_1 = \dot{W}_{a,\text{out}} + \dot{m}h_2 \quad (\text{since } \dot{Q} \cong \Delta \text{ke} \cong \Delta \text{pe} \cong 0)$$

$$\dot{W}_{a,\text{out}} = \dot{m}(h_1 - h_2)$$

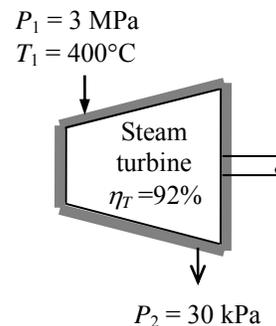

From the steam tables (Tables A-4 through A-6),

$$\left. \begin{array}{l} P_1 = 3 \text{ MPa} \\ T_1 = 400^\circ\text{C} \end{array} \right\} \begin{array}{l} h_1 = 3231.7 \text{ kJ/kg} \\ s_1 = 6.9235 \text{ kJ/kg} \cdot \text{K} \end{array}$$

$$\left. \begin{array}{l} P_{2s} = 30 \text{ kPa} \\ s_{2s} = s_1 \end{array} \right\} \begin{array}{l} x_{2s} = \frac{s_{2s} - s_f}{s_{fg}} = \frac{6.9235 - 0.9441}{6.8234} = 0.8763 \\ h_{2s} = h_f + x_{2s} h_{fg} = 289.27 + (0.8763)(2335.3) = 2335.7 \text{ kJ/kg} \end{array}$$

The actual power output may be determined by multiplying the isentropic power output with the isentropic efficiency. Then,

$$\begin{aligned} \dot{W}_{a,\text{out}} &= \eta_T \dot{W}_{s,\text{out}} \\ &= \eta_T \dot{m}(h_1 - h_{2s}) \\ &= (0.92)(2 \text{ kg/s})(3231.7 - 2335.7) \text{ kJ/kg} \\ &= \mathbf{1649 \text{ kW}} \end{aligned}$$

7-129 Steam is expanded in an adiabatic turbine with an isentropic efficiency of 0.90. The power output of the turbine is to be determined.

Assumptions 1 This is a steady-flow process since there is no change with time. **2** Kinetic and potential energy changes are negligible. **3** The device is adiabatic and thus heat transfer is negligible.

Analysis There is only one inlet and one exit, and thus $\dot{m}_1 = \dot{m}_2 = \dot{m}$. We take the actual turbine as the system, which is a control volume since mass crosses the boundary. The energy balance for this steady-flow system can be expressed in the rate form as

$$\underbrace{\dot{E}_{\text{in}} - \dot{E}_{\text{out}}}_{\substack{\text{Rate of net energy transfer} \\ \text{by heat, work, and mass}}} = \underbrace{\Delta \dot{E}_{\text{system}}^{\phi 0} \text{ (steady)}}_{\substack{\text{Rate of change in internal, kinetic,} \\ \text{potential, etc. energies}}} = 0$$

$$\dot{E}_{\text{in}} = \dot{E}_{\text{out}}$$

$$\dot{m}h_1 = \dot{W}_{a,\text{out}} + \dot{m}h_2 \quad (\text{since } \dot{Q} \cong \Delta \text{ke} \cong \Delta \text{pe} \cong 0)$$

$$\dot{W}_{a,\text{out}} = \dot{m}(h_1 - h_2)$$

From the steam tables (Tables A-4 through A-6),

$$\left. \begin{array}{l} P_1 = 3 \text{ MPa} \\ T_1 = 400^\circ\text{C} \end{array} \right\} \begin{array}{l} h_1 = 3231.7 \text{ kJ/kg} \\ s_1 = 6.9235 \text{ kJ/kg} \cdot \text{K} \end{array}$$

$$\left. \begin{array}{l} P_{2s} = 30 \text{ kPa} \\ s_{2s} = s_1 \end{array} \right\} \begin{array}{l} x_{2s} = \frac{s_{2s} - s_f}{s_{fg}} = \frac{6.9235 - 0.9441}{6.8234} = 0.8763 \\ h_{2s} = h_f + x_{2s} h_{fg} = 289.27 + (0.8763)(2335.3) = 2335.7 \text{ kJ/kg} \end{array}$$

The actual power output may be determined by multiplying the isentropic power output with the isentropic efficiency. Then,

$$\begin{aligned} \dot{W}_{a,\text{out}} &= \eta_T \dot{W}_{s,\text{out}} \\ &= \eta_T \dot{m}(h_1 - h_{2s}) \\ &= (0.90)(2 \text{ kg/s})(3231.7 - 2335.7) \text{ kJ/kg} \\ &= \mathbf{1613 \text{ kW}} \end{aligned}$$

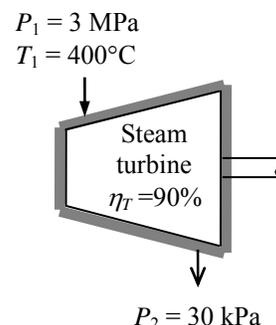

7-130 Argon gas is compressed by an adiabatic compressor. The isentropic efficiency of the compressor is to be determined.

Assumptions 1 This is a steady-flow process since there is no change with time. **2** Kinetic and potential energy changes are negligible. **3** The device is adiabatic and thus heat transfer is negligible. **4** Argon is an ideal gas with constant specific heats.

Properties The specific heat ratio of argon is $k = 1.667$ (Table A-2).

Analysis The isentropic exit temperature is

$$T_{2s} = T_1 \left(\frac{P_{2s}}{P_1} \right)^{(k-1)/k} = (300 \text{ K}) \left(\frac{2000 \text{ kPa}}{200 \text{ kPa}} \right)^{0.667/1.667} = 753.8 \text{ K}$$

From the isentropic efficiency relation,

$$\eta_C = \frac{w_s}{w_a} = \frac{h_{2s} - h_1}{h_{2a} - h_1} = \frac{c_p(T_{2s} - T_1)}{c_p(T_{2a} - T_1)} = \frac{T_{2s} - T_1}{T_{2a} - T_1}$$

$$= \frac{753.8 - 300}{823 - 300} = 0.867 = \mathbf{86.7\%}$$

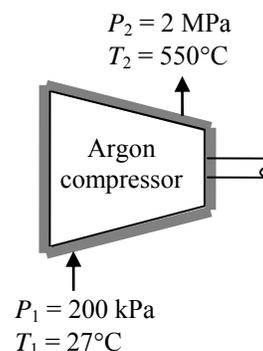

7-131 R-134a is compressed by an adiabatic compressor. The isentropic efficiency of the compressor is to be determined.

Assumptions 1 This is a steady-flow process since there is no change with time. **2** Kinetic and potential energy changes are negligible. **3** The device is adiabatic and thus heat transfer is negligible.

Analysis From the R-134a tables (Tables A-11 through A-13),

$$\left. \begin{array}{l} T_1 = 0^\circ\text{C} \\ x = 1 \text{ (sat. vap.)} \end{array} \right\} \begin{array}{l} h_1 = 250.45 \text{ kJ/kg} \\ s_1 = 0.93139 \text{ kJ/kg}\cdot\text{K} \end{array}$$

$$\left. \begin{array}{l} P_2 = 600 \text{ kPa} \\ T_2 = 50^\circ\text{C} \end{array} \right\} h_{2a} = 290.28 \text{ kJ/kg}$$

$$\left. \begin{array}{l} P_2 = 600 \text{ kPa} \\ s_2 = s_1 = 0.93139 \text{ kJ/kg}\cdot\text{K} \end{array} \right\} h_{2s} = 265.25 \text{ kJ/kg}$$

From the isentropic efficiency relation,

$$\eta_C = \frac{w_s}{w_a} = \frac{h_{2s} - h_1}{h_{2a} - h_1} = \frac{265.25 - 250.45}{290.28 - 250.45} = 0.372 = \mathbf{37.2\%}$$

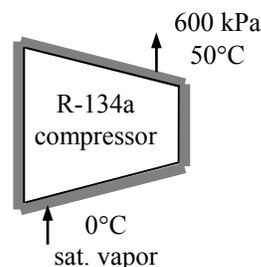

7-132 Steam enters an adiabatic turbine at a specified state, and leaves at a specified state. The mass flow rate of the steam and the isentropic efficiency are to be determined.

Assumptions 1 This is a steady-flow process since there is no change with time. **2** Potential energy changes are negligible. **3** The device is adiabatic and thus heat transfer is negligible.

Analysis (a) From the steam tables (Tables A-4 and A-6),

$$\left. \begin{array}{l} P_1 = 7 \text{ MPa} \\ T_1 = 600^\circ\text{C} \end{array} \right\} \begin{array}{l} h_1 = 3650.6 \text{ kJ/kg} \\ s_1 = 7.0910 \text{ kJ/kg} \cdot \text{K} \end{array}$$

$$\left. \begin{array}{l} P_2 = 50 \text{ kPa} \\ T_2 = 150^\circ\text{C} \end{array} \right\} h_{2a} = 2780.2 \text{ kJ/kg}$$

There is only one inlet and one exit, and thus $\dot{m}_1 = \dot{m}_2 = \dot{m}$. We take the actual turbine as the system, which is a control volume since mass crosses the boundary. The energy balance for this steady-flow system can be expressed in the rate form as

$$\underbrace{\dot{E}_{\text{in}} - \dot{E}_{\text{out}}}_{\text{Rate of net energy transfer by heat, work, and mass}} = \underbrace{\Delta \dot{E}_{\text{system}}}_{\text{Rate of change in internal, kinetic, potential, etc. energies}} \stackrel{\approx 0 \text{ (steady)}}{=} 0$$

$$\dot{E}_{\text{in}} = \dot{E}_{\text{out}}$$

$$\dot{m}(h_1 + V_1^2/2) = \dot{W}_{\text{a,out}} + \dot{m}(h_2 + V_2^2/2) \quad (\text{since } \dot{Q} \cong \Delta \text{pe} \cong 0)$$

$$\dot{W}_{\text{a,out}} = -\dot{m} \left(h_2 - h_1 + \frac{V_2^2 - V_1^2}{2} \right)$$

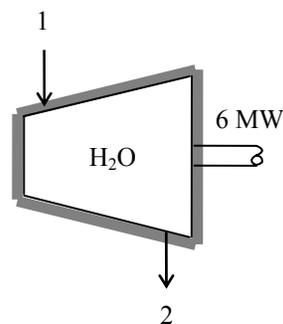

Substituting, the mass flow rate of the steam is determined to be

$$6000 \text{ kJ/s} = -\dot{m} \left(2780.2 - 3650.6 + \frac{(140 \text{ m/s})^2 - (80 \text{ m/s})^2}{2} \left(\frac{1 \text{ kJ/kg}}{1000 \text{ m}^2/\text{s}^2} \right) \right)$$

$$\dot{m} = \mathbf{6.95 \text{ kg/s}}$$

(b) The isentropic exit enthalpy of the steam and the power output of the isentropic turbine are

$$\left. \begin{array}{l} P_{2s} = 50 \text{ kPa} \\ s_{2s} = s_1 \end{array} \right\} \begin{array}{l} x_{2s} = \frac{s_{2s} - s_f}{s_{fg}} = \frac{7.0910 - 1.0912}{6.5019} = 0.9228 \\ h_{2s} = h_f + x_{2s}h_{fg} = 340.54 + (0.9228)(2304.7) = 2467.3 \text{ kJ/kg} \end{array}$$

and

$$\dot{W}_{\text{s,out}} = -\dot{m} \left(h_{2s} - h_1 + \frac{V_2^2 - V_1^2}{2} \right)$$

$$\dot{W}_{\text{s,out}} = -(6.95 \text{ kg/s}) \left(2467.3 - 3650.6 + \frac{(140 \text{ m/s})^2 - (80 \text{ m/s})^2}{2} \left(\frac{1 \text{ kJ/kg}}{1000 \text{ m}^2/\text{s}^2} \right) \right)$$

$$= 8174 \text{ kW}$$

Then the isentropic efficiency of the turbine becomes

$$\eta_r = \frac{\dot{W}_a}{\dot{W}_s} = \frac{6000 \text{ kW}}{8174 \text{ kW}} = 0.734 = \mathbf{73.4\%}$$

7-133 Argon enters an adiabatic turbine at a specified state with a specified mass flow rate, and leaves at a specified pressure. The isentropic efficiency of the turbine is to be determined.

Assumptions 1 This is a steady-flow process since there is no change with time. **2** Kinetic and potential energy changes are negligible. **3** The device is adiabatic and thus heat transfer is negligible. **4** Argon is an ideal gas with constant specific heats.

Properties The specific heat ratio of argon is $k = 1.667$. The constant pressure specific heat of argon is $c_p = 0.5203 \text{ kJ/kg}\cdot\text{K}$ (Table A-2).

Analysis There is only one inlet and one exit, and thus $\dot{m}_1 = \dot{m}_2 = \dot{m}$. We take the isentropic turbine as the system, which is a control volume since mass crosses the boundary. The energy balance for this steady-flow system can be expressed in the rate form as

$$\begin{aligned}\dot{E}_{\text{in}} &= \dot{E}_{\text{out}} \\ \dot{m}h_1 &= \dot{W}_{s,\text{out}} + \dot{m}h_{2s} \quad (\text{since } \dot{Q} \cong \Delta ke \cong \Delta pe \cong 0) \\ \dot{W}_{s,\text{out}} &= \dot{m}(h_1 - h_{2s})\end{aligned}$$

From the isentropic relations,

$$T_{2s} = T_1 \left(\frac{P_{2s}}{P_1} \right)^{(k-1)/k} = (1073 \text{ K}) \left(\frac{200 \text{ kPa}}{1500 \text{ kPa}} \right)^{0.667/1.667} = 479 \text{ K}$$

Then the power output of the isentropic turbine becomes

$$\dot{W}_{s,\text{out}} = \dot{m}c_p(T_1 - T_{2s}) = (80/60 \text{ kg/min})(0.5203 \text{ kJ/kg}\cdot\text{K})(1073 - 479) = 412.1 \text{ kW}$$

Then the isentropic efficiency of the turbine is determined from

$$\eta_T = \frac{\dot{W}_a}{\dot{W}_s} = \frac{370 \text{ kW}}{412.1 \text{ kW}} = 0.898 = \mathbf{89.8\%}$$

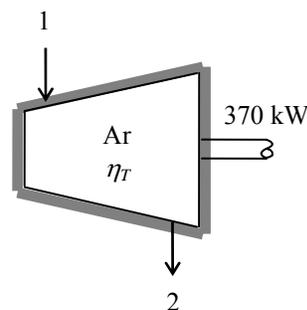

7-134E Combustion gases enter an adiabatic gas turbine with an isentropic efficiency of 82% at a specified state, and leave at a specified pressure. The work output of the turbine is to be determined.

Assumptions 1 This is a steady-flow process since there is no change with time. **2** Kinetic and potential energy changes are negligible. **3** The device is adiabatic and thus heat transfer is negligible. **4** Combustion gases can be treated as air that is an ideal gas with variable specific heats.

Analysis From the air table and isentropic relations,

$$T_1 = 2000 \text{ R} \quad \longrightarrow \quad \begin{aligned} h_1 &= 504.71 \text{ Btu/lbm} \\ P_{r_1} &= 174.0 \end{aligned}$$

$$P_{r_2} = \left(\frac{P_2}{P_1} \right) P_{r_1} = \left(\frac{60 \text{ psia}}{120 \text{ psia}} \right) (174.0) = 87.0 \quad \longrightarrow \quad h_{2s} = 417.3 \text{ Btu/lbm}$$

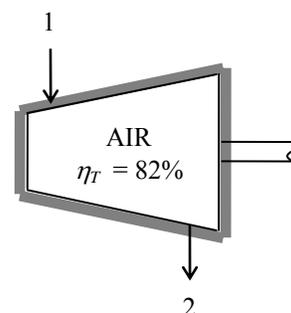

There is only one inlet and one exit, and thus $\dot{m}_1 = \dot{m}_2 = \dot{m}$. We take the actual turbine as the system, which is a control volume since mass crosses the boundary. The energy balance for this steady-flow system can be expressed as

$$\begin{aligned} \dot{E}_{\text{in}} &= \dot{E}_{\text{out}} \\ \dot{m}h_1 &= \dot{W}_{\text{a,out}} + \dot{m}h_2 \quad (\text{since } \dot{Q} \cong \Delta \text{ke} \cong \Delta \text{pe} \cong 0) \\ \dot{W}_{\text{a,out}} &= \dot{m}(h_1 - h_2) \end{aligned}$$

Noting that $w_a = \eta_T w_s$, the work output of the turbine per unit mass is determined from

$$w_a = (0.82)(504.71 - 417.3) \text{ Btu/lbm} = \mathbf{71.7 \text{ Btu/lbm}}$$

7-135 [Also solved by EES on enclosed CD] Refrigerant-134a enters an adiabatic compressor with an isentropic efficiency of 0.80 at a specified state with a specified volume flow rate, and leaves at a specified pressure. The compressor exit temperature and power input to the compressor are to be determined.

Assumptions 1 This is a steady-flow process since there is no change with time. **2** Kinetic and potential energy changes are negligible. **3** The device is adiabatic and thus heat transfer is negligible.

Analysis (a) From the refrigerant tables (Tables A-11E through A-13E),

$$P_1 = 120 \text{ kPa} \left. \begin{array}{l} h_1 = h_{g@120 \text{ kPa}} = 236.97 \text{ kJ/kg} \\ s_1 = s_{g@120 \text{ kPa}} = 0.94779 \text{ kJ/kg} \cdot \text{K} \\ \nu_1 = \nu_{g@120 \text{ kPa}} = 0.16212 \text{ m}^3/\text{kg} \end{array} \right\} \text{sat. vapor}$$

$$P_2 = 1 \text{ MPa} \left. \begin{array}{l} h_{2s} = 281.21 \text{ kJ/kg} \\ s_{2s} = s_1 \end{array} \right\}$$

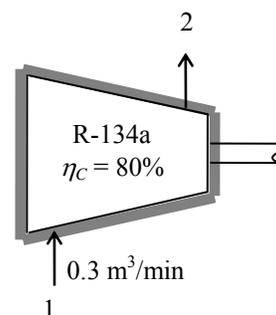

From the isentropic efficiency relation,

$$\eta_c = \frac{h_{2s} - h_1}{h_{2a} - h_1} \longrightarrow h_{2a} = h_1 + (h_{2s} - h_1)/\eta_c = 236.97 + (281.21 - 236.97)/0.80 = 292.26 \text{ kJ/kg}$$

Thus,

$$\left. \begin{array}{l} P_{2a} = 1 \text{ MPa} \\ h_{2a} = 292.26 \text{ kJ/kg} \end{array} \right\} T_{2a} = \mathbf{58.9^\circ\text{C}}$$

(b) The mass flow rate of the refrigerant is determined from

$$\dot{m} = \frac{\dot{V}_1}{\nu_1} = \frac{0.3/60 \text{ m}^3/\text{s}}{0.16212 \text{ m}^3/\text{kg}} = 0.0308 \text{ kg/s}$$

There is only one inlet and one exit, and thus $\dot{m}_1 = \dot{m}_2 = \dot{m}$. We take the actual compressor as the system, which is a control volume since mass crosses the boundary. The energy balance for this steady-flow system can be expressed as

$$\underbrace{\dot{E}_{\text{in}} - \dot{E}_{\text{out}}}_{\text{Rate of net energy transfer by heat, work, and mass}} = \underbrace{\Delta \dot{E}_{\text{system}}}_{\text{Rate of change in internal, kinetic, potential, etc. energies}} \stackrel{\neq 0 \text{ (steady)}}{=} 0$$

$$\dot{E}_{\text{in}} = \dot{E}_{\text{out}}$$

$$\dot{W}_{\text{a,in}} + \dot{m}h_1 = \dot{m}h_2 \quad (\text{since } \dot{Q} \cong \Delta \text{ke} \cong \Delta \text{pe} \cong 0)$$

$$\dot{W}_{\text{a,in}} = \dot{m}(h_2 - h_1)$$

Substituting, the power input to the compressor becomes,

$$\dot{W}_{\text{a,in}} = (0.0308 \text{ kg/s})(292.26 - 236.97) \text{ kJ/kg} = \mathbf{1.70 \text{ kW}}$$

7-136 EES Problem 7-135 is reconsidered. The problem is to be solved by considering the kinetic energy and by assuming an inlet-to-exit area ratio of 1.5 for the compressor when the compressor exit pipe inside diameter is 2 cm.

Analysis The problem is solved using EES, and the solution is given below.

"Input Data from diagram window"

```
{P[1] = 120 "kPa"
P[2] = 1000 "kPa"
Vol_dot_1 = 0.3 "m^3/min"
Eta_c = 0.80 "Compressor adiabatic efficiency"
A_ratio = 1.5
d_2 = 2/100 "m"}
```

"System: Control volume containing the compressor, see the diagram window.

Property Relation: Use the real fluid properties for R134a.

Process: Steady-state, steady-flow, adiabatic process."

Fluid\$='R134a'

"Property Data for state 1"

```
T[1]=temperature(Fluid$,P=P[1],x=1)"Real fluid equ. at the sat. vapor state"
h[1]=enthalpy(Fluid$, P=P[1], x=1)"Real fluid equ. at the sat. vapor state"
s[1]=entropy(Fluid$, P=P[1], x=1)"Real fluid equ. at the sat. vapor state"
v[1]=volume(Fluid$, P=P[1], x=1)"Real fluid equ. at the sat. vapor state"
```

"Property Data for state 2"

```
s_s[1]=s[1]; T_s[1]=T[1] "needed for plot"
s_s[2]=s[1] "for the ideal, isentropic process across the compressor"
h_s[2]=ENTHALPY(Fluid$, P=P[2], s=s_s[2])"Enthalpy 2 at the isentropic state 2s and
pressure P[2]"
T_s[2]=Temperature(Fluid$, P=P[2], s=s_s[2])"Temperature of ideal state - needed only for
plot."
```

"Steady-state, steady-flow conservation of mass"

```
m_dot_1 = m_dot_2
m_dot_1 = Vol_dot_1/(v[1]*60)
Vol_dot_1/v[1]=Vol_dot_2/v[2]
Vel[2]=Vol_dot_2/(A[2]*60)
A[2] = pi*(d_2)^2/4
A_ratio*Vel[1]/v[1] = Vel[2]/v[2] "Mass flow rate: = A*Vel/v, A_ratio = A[1]/A[2]"
A_ratio=A[1]/A[2]
```

"Steady-state, steady-flow conservation of energy, adiabatic compressor, see diagram window"

```
m_dot_1*(h[1]+(Vel[1])^2/(2*1000)) + W_dot_c = m_dot_2*(h[2]+(Vel[2])^2/(2*1000))
```

"Definition of the compressor adiabatic efficiency, $\text{Eta}_c = W_{\text{isen}}/W_{\text{act}}$ "

```
Eta_c = (h_s[2]-h[1])/(h[2]-h[1])
```

"Knowing $h[2]$, the other properties at state 2 can be found."

```
v[2]=volume(Fluid$, P=P[2], h=h[2])"v[2] is found at the actual state 2, knowing P and h."
T[2]=temperature(Fluid$, P=P[2],h=h[2])"Real fluid equ. for T at the known outlet h and P."
s[2]=entropy(Fluid$, P=P[2], h=h[2]) "Real fluid equ. at the known outlet h and P."
T_exit=T[2]
```

"Neglecting the kinetic energies, the work is:"

```
m_dot_1*h[1] + W_dot_c_noke = m_dot_2*h[2]
```

SOLUTION

$A[1]=0.0004712 \text{ [m}^2\text{]}$
 $A[2]=0.0003142 \text{ [m}^2\text{]}$
 $A_{\text{ratio}}=1.5$
 $d_2=0.02 \text{ [m]}$
 $\text{Eta}_c=0.8$
 $\text{Fluid}=\text{'R134a'}$
 $h[1]=237 \text{ [kJ/kg]}$
 $h[2]=292.3 \text{ [kJ/kg]}$
 $h_s[2]=281.2 \text{ [kJ/kg]}$
 $m_{\text{dot}}_1=0.03084 \text{ [kg/s]}$
 $m_{\text{dot}}_2=0.03084 \text{ [kg/s]}$
 $P[1]=120.0 \text{ [kPa]}$
 $P[2]=1000.0 \text{ [kPa]}$
 $s[1]=0.9478 \text{ [kJ/kg-K]}$
 $s[2]=0.9816 \text{ [kJ/kg-K]}$

$s_s[1]=0.9478 \text{ [kJ/kg-K]}$
 $s_s[2]=0.9478 \text{ [kJ/kg-K]}$
 $T[1]=-22.32 \text{ [C]}$
 $T[2]=58.94 \text{ [C]}$
 $T_{\text{exit}}=58.94 \text{ [C]}$
 $T_s[1]=-22.32 \text{ [C]}$
 $T_s[2]=48.58 \text{ [C]}$
 $\text{Vol}_{\text{dot}}_1=0.3 \text{ [m}^3\text{/min]}$
 $\text{Vol}_{\text{dot}}_2=0.04244 \text{ [m}^3\text{/min]}$
 $v[1]=0.1621 \text{ [m}^3\text{/kg]}$
 $v[2]=0.02294 \text{ [m}^3\text{/kg]}$
 $\text{Vel}[1]=10.61 \text{ [m/s]}$
 $\text{Vel}[2]=2.252 \text{ [m/s]}$
 $W_{\text{dot}}_c=1.704 \text{ [kW]}$
 $W_{\text{dot}}_c_{\text{noke}}=1.706 \text{ [kW]}$

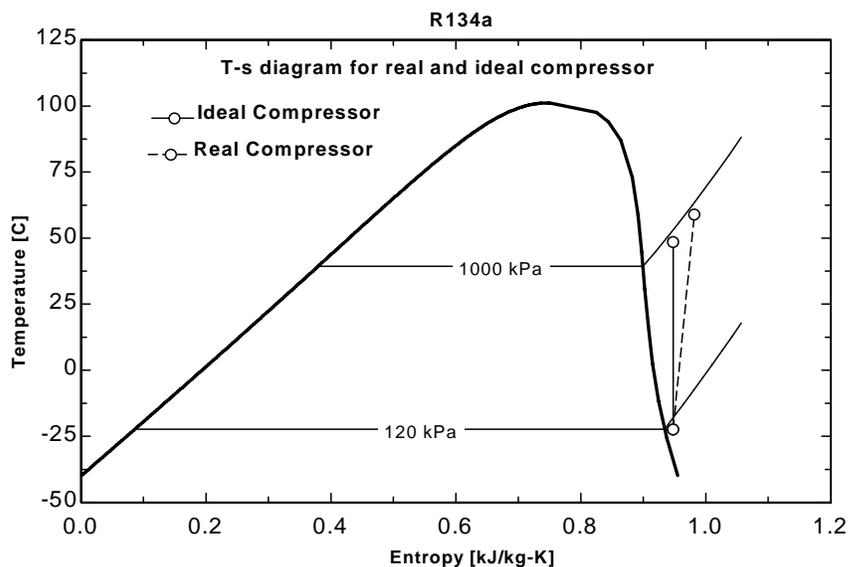

7-137 Air enters an adiabatic compressor with an isentropic efficiency of 84% at a specified state, and leaves at a specified temperature. The exit pressure of air and the power input to the compressor are to be determined.

Assumptions 1 This is a steady-flow process since there is no change with time. **2** Kinetic and potential energy changes are negligible. **3** The device is adiabatic and thus heat transfer is negligible. **4** Air is an ideal gas with variable specific heats.

Properties The gas constant of air is $R = 0.287 \text{ kPa}\cdot\text{m}^3/\text{kg}\cdot\text{K}$ (Table A-1)

Analysis (a) From the air table (Table A-17),

$$T_1 = 290 \text{ K} \longrightarrow h_1 = 290.16 \text{ kJ/kg}, \quad P_{r1} = 1.2311$$

$$T_2 = 530 \text{ K} \longrightarrow h_{2a} = 533.98 \text{ kJ/kg}$$

From the isentropic efficiency relation $\eta_c = \frac{h_{2s} - h_1}{h_{2a} - h_1}$,

$$\begin{aligned} h_{2s} &= h_1 + \eta_c (h_{2a} - h_1) \\ &= 290.16 + (0.84)(533.98 - 290.16) = 495.0 \text{ kJ/kg} \longrightarrow P_{r2} = 7.951 \end{aligned}$$

Then from the isentropic relation ,

$$\frac{P_2}{P_1} = \frac{P_{r2}}{P_{r1}} \longrightarrow P_2 = \left(\frac{P_{r2}}{P_{r1}} \right) P_1 = \left(\frac{7.951}{1.2311} \right) (100 \text{ kPa}) = \mathbf{646 \text{ kPa}}$$

(b) There is only one inlet and one exit, and thus $\dot{m}_1 = \dot{m}_2 = \dot{m}$. We take the actual compressor as the system, which is a control volume since mass crosses the boundary. The energy balance for this steady-flow system can be expressed as

$$\underbrace{\dot{E}_{\text{in}} - \dot{E}_{\text{out}}}_{\text{Rate of net energy transfer by heat, work, and mass}} = \underbrace{\Delta \dot{E}_{\text{system}}}_{\text{Rate of change in internal, kinetic, potential, etc. energies}} \stackrel{\neq 0 \text{ (steady)}}{=} 0$$

$$\dot{E}_{\text{in}} = \dot{E}_{\text{out}}$$

$$\dot{W}_{\text{a,in}} + \dot{m}h_1 = \dot{m}h_2 \quad (\text{since } \dot{Q} \cong \Delta \text{ke} \cong \Delta \text{pe} \cong 0)$$

$$\dot{W}_{\text{a,in}} = \dot{m}(h_2 - h_1)$$

where

$$\dot{m} = \frac{P_1 \dot{V}_1}{RT_1} = \frac{(100 \text{ kPa})(2.4 \text{ m}^3/\text{s})}{(0.287 \text{ kPa}\cdot\text{m}^3/\text{kg}\cdot\text{K})(290 \text{ K})} = 2.884 \text{ kg/s}$$

Then the power input to the compressor is determined to be

$$\dot{W}_{\text{a,in}} = (2.884 \text{ kg/s})(533.98 - 290.16) \text{ kJ/kg} = \mathbf{703 \text{ kW}}$$

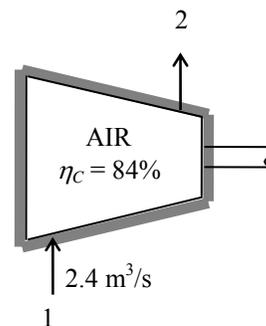

7-138 Air is compressed by an adiabatic compressor from a specified state to another specified state. The isentropic efficiency of the compressor and the exit temperature of air for the isentropic case are to be determined.

Assumptions 1 This is a steady-flow process since there is no change with time. **2** Kinetic and potential energy changes are negligible. **3** The device is adiabatic and thus heat transfer is negligible. **4** Air is an ideal gas with variable specific heats.

Analysis (a) From the air table (Table A-17),

$$T_1 = 300 \text{ K} \longrightarrow h_1 = 300.19 \text{ kJ/kg}, \quad P_{r_1} = 1.386$$

$$T_2 = 550 \text{ K} \longrightarrow h_{2a} = 554.74 \text{ kJ/kg}$$

From the isentropic relation,

$$P_{r_2} = \left(\frac{P_2}{P_1} \right) P_{r_1} = \left(\frac{600 \text{ kPa}}{95 \text{ kPa}} \right) (1.386) = 8.754 \longrightarrow h_{2s} = 508.72 \text{ kJ/kg}$$

Then the isentropic efficiency becomes

$$\eta_c = \frac{h_{2s} - h_1}{h_{2a} - h_1} = \frac{508.72 - 300.19}{554.74 - 300.19} = 0.819 = \mathbf{81.9\%}$$

(b) If the process were isentropic, the exit temperature would be

$$h_{2s} = 508.72 \text{ kJ/kg} \longrightarrow T_{2s} = \mathbf{505.5 \text{ K}}$$

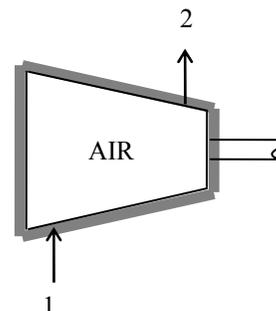

7-139E Argon enters an adiabatic compressor with an isentropic efficiency of 80% at a specified state, and leaves at a specified pressure. The exit temperature of argon and the work input to the compressor are to be determined.

Assumptions 1 This is a steady-flow process since there is no change with time. **2** Potential energy changes are negligible. **3** The device is adiabatic and thus heat transfer is negligible. **4** Argon is an ideal gas with constant specific heats.

Properties The specific heat ratio of argon is $k = 1.667$. The constant pressure specific heat of argon is $c_p = 0.1253 \text{ Btu/lbm}\cdot\text{R}$ (Table A-2E).

Analysis (a) The isentropic exit temperature T_{2s} is determined from

$$T_{2s} = T_1 \left(\frac{P_{2s}}{P_1} \right)^{(k-1)/k} = (550 \text{ R}) \left(\frac{200 \text{ psia}}{20 \text{ psia}} \right)^{0.667/1.667} = 1381.9 \text{ R}$$

The actual kinetic energy change during this process is

$$\Delta ke_a = \frac{V_2^2 - V_1^2}{2} = \frac{(240 \text{ ft/s})^2 - (60 \text{ ft/s})^2}{2} \left(\frac{1 \text{ Btu/lbm}}{25,037 \text{ ft}^2/\text{s}^2} \right) = 1.08 \text{ Btu/lbm}$$

The effect of kinetic energy on isentropic efficiency is very small. Therefore, we can take the kinetic energy changes for the actual and isentropic cases to be same in efficiency calculations. From the isentropic efficiency relation, including the effect of kinetic energy,

$$\eta_c = \frac{w_s}{w_a} = \frac{(h_{2s} - h_1) + \Delta ke}{(h_{2a} - h_1) + \Delta ke} = \frac{c_p(T_{2s} - T_1) + \Delta ke_s}{c_p(T_{2a} - T_1) + \Delta ke_a} \longrightarrow 0.8 = \frac{0.1253(1381.9 - 550) + 1.08}{0.1253(T_{2a} - 550) + 1.08}$$

It yields

$$T_{2a} = \mathbf{1592 \text{ R}}$$

(b) There is only one inlet and one exit, and thus $\dot{m}_1 = \dot{m}_2 = \dot{m}$. We take the actual compressor as the system, which is a control volume since mass crosses the boundary. The energy balance for this steady-flow system can be expressed as

$$\underbrace{\dot{E}_{\text{in}} - \dot{E}_{\text{out}}}_{\text{Rate of net energy transfer by heat, work, and mass}} = \underbrace{\Delta \dot{E}_{\text{system}}^{\neq 0} (\text{steady})}_{\text{Rate of change in internal, kinetic, potential, etc. energies}} = 0$$

$$\dot{E}_{\text{in}} = \dot{E}_{\text{out}}$$

$$\dot{W}_{\text{a,in}} + \dot{m}(h_1 + V_1^2/2) = \dot{m}(h_2 + V_2^2/2) \quad (\text{since } \dot{Q} \equiv \Delta pe \equiv 0)$$

$$\dot{W}_{\text{a,in}} = \dot{m} \left(h_2 - h_1 + \frac{V_2^2 - V_1^2}{2} \right) \longrightarrow w_{\text{a,in}} = h_2 - h_1 + \Delta ke$$

Substituting, the work input to the compressor is determined to be

$$w_{\text{a,in}} = (0.1253 \text{ Btu/lbm}\cdot\text{R})(1592 - 550)\text{R} + 1.08 \text{ Btu/lbm} = \mathbf{131.6 \text{ Btu/lbm}}$$

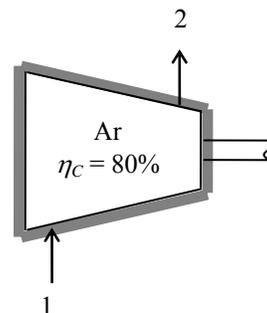

7-140E Air is accelerated in a 90% efficient adiabatic nozzle from low velocity to a specified velocity. The exit temperature and pressure of the air are to be determined.

Assumptions 1 This is a steady-flow process since there is no change with time. **2** Potential energy changes are negligible. **3** The device is adiabatic and thus heat transfer is negligible. **4** Air is an ideal gas with variable specific heats.

Analysis From the air table (Table A-17E),

$$T_1 = 1480 \text{ R} \longrightarrow h_1 = 363.89 \text{ Btu/lbm}, \quad P_{r_1} = 53.04$$

There is only one inlet and one exit, and thus $\dot{m}_1 = \dot{m}_2 = \dot{m}$. We take the nozzle as the system, which is a control volume since mass crosses the boundary. The energy balance for this steady-flow system can be expressed as

$$\underbrace{\dot{E}_{\text{in}} - \dot{E}_{\text{out}}}_{\text{Rate of net energy transfer by heat, work, and mass}} = \underbrace{\Delta \dot{E}_{\text{system}}}_{\text{Rate of change in internal, kinetic, potential, etc. energies}} \stackrel{\neq 0}{\text{(steady)}} = 0$$

$$\dot{E}_{\text{in}} = \dot{E}_{\text{out}}$$

$$\dot{m}(h_1 + V_1^2/2) = \dot{m}(h_2 + V_2^2/2) \quad (\text{since } \dot{W} = \dot{Q} \cong \Delta p_e \cong 0)$$

$$h_2 = h_1 - \frac{V_2^2 - V_1^2}{2}$$

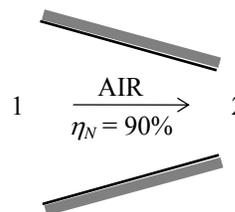

Substituting, the exit temperature of air is determined to be

$$h_2 = 363.89 \text{ kJ/kg} - \frac{(800 \text{ ft/s})^2 - 0}{2} \left(\frac{1 \text{ Btu/lbm}}{25,037 \text{ ft}^2/\text{s}^2} \right) = 351.11 \text{ Btu/lbm}$$

From the air table we read

$$T_{2a} = \mathbf{1431.3 \text{ R}}$$

From the isentropic efficiency relation

$$\eta_N = \frac{h_{2a} - h_1}{h_{2s} - h_1} \longrightarrow$$

$$h_{2s} = h_1 + (h_{2a} - h_1)/\eta_N = 363.89 + (351.11 - 363.89)/(0.90) = 349.69 \text{ Btu/lbm} \longrightarrow P_{r_2} = 46.04$$

Then the exit pressure is determined from the isentropic relation to be

$$\frac{P_2}{P_1} = \frac{P_{r_2}}{P_{r_1}} \longrightarrow P_2 = \left(\frac{P_{r_2}}{P_{r_1}} \right) P_1 = \left(\frac{46.04}{53.04} \right) (60 \text{ psia}) = \mathbf{52.1 \text{ psia}}$$

7-141E EES Problem 7-140E is reconsidered. The effect of varying the nozzle isentropic efficiency from 0.8 to 1.0 on the exit temperature and pressure of the air is to be investigated, and the results are to be plotted.

Analysis The problem is solved using EES, and the results are tabulated and plotted below.

"Knowns:"

WorkFluid\$ = 'Air'
 P[1] = 60 [psia]
 T[1] = 1020 [F]
 Vel[2] = 800 [ft/s]
 Vel[1] = 0 [ft/s]
 eta_nozzle = 0.9

"Conservation of Energy - SSSF energy balance for turbine -- neglecting the change in potential energy, no heat transfer:"

h[1]=enthalpy(WorkFluid\$,T=T[1])
 s[1]=entropy(WorkFluid\$,P=P[1],T=T[1])
 T_s[1] = T[1]
 s[2] = s[1]
 s_s[2] = s[1]
 h_s[2]=enthalpy(WorkFluid\$,T=T_s[2])
 T_s[2]=temperature(WorkFluid\$,P=P[2],s=s_s[2])
 eta_nozzle = ke[2]/ke_s[2]
 ke[1] = Vel[1]^2/2
 ke[2]=Vel[2]^2/2
 h[1]+ke[1]*convert(ft^2/s^2,Btu/lbm) = h[2] + ke[2]*convert(ft^2/s^2,Btu/lbm)
 h[1] +ke[1]*convert(ft^2/s^2,Btu/lbm) = h_s[2] + ke_s[2]*convert(ft^2/s^2,Btu/lbm)
 T[2]=temperature(WorkFluid\$,h=h[2])
 P_2_answer = P[2]
 T_2_answer = T[2]

η_{nozzle}	P_2 [psia]	T_2 [F]	$T_{s,2}$ [F]
0.8	51.09	971.4	959.2
0.85	51.58	971.4	962.8
0.9	52.03	971.4	966
0.95	52.42	971.4	968.8
1	52.79	971.4	971.4

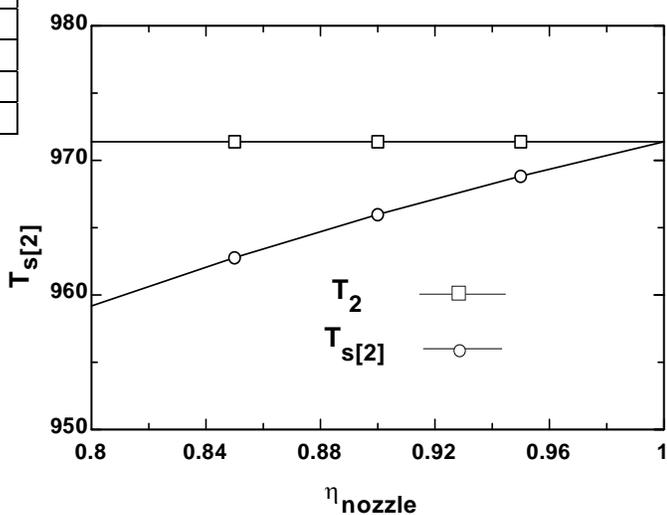

7-142 Air is expanded in an adiabatic nozzle with an isentropic efficiency of 0.96. The air velocity at the exit is to be determined.

Assumptions 1 This is a steady-flow process since there is no change with time. **2** There is no heat transfer or shaft work associated with the process. **3** Air is an ideal gas with constant specific heats.

Properties The properties of air at room temperature are $c_p = 1.005 \text{ kJ/kg}\cdot\text{K}$ and $k = 1.4$ (Table A-2a).

Analysis For the isentropic process of an ideal gas, the exit temperature is determined from

$$T_{2s} = T_1 \left(\frac{P_2}{P_1} \right)^{(k-1)/k} = (180 + 273 \text{ K}) \left(\frac{100 \text{ kPa}}{300 \text{ kPa}} \right)^{0.4/1.4} = 331.0 \text{ K}$$

There is only one inlet and one exit, and thus $\dot{m}_1 = \dot{m}_2 = \dot{m}$. We take nozzle as the system, which is a control volume since mass crosses the boundary. The energy balance for this steady-flow system can be expressed in the rate form as

$$\underbrace{\dot{E}_{\text{in}} - \dot{E}_{\text{out}}}_{\text{Rate of net energy transfer by heat, work, and mass}} = \underbrace{\Delta \dot{E}_{\text{system}}^{\text{no (steady)}}}_{\text{Rate of change in internal, kinetic, potential, etc. energies}} = 0$$

$$\dot{E}_{\text{in}} = \dot{E}_{\text{out}}$$

$$\dot{m} \left(h_1 + \frac{V_1^2}{2} \right) = \dot{m} \left(h_2 + \frac{V_2^2}{2} \right)$$

$$h_1 + \frac{V_1^2}{2} = h_2 + \frac{V_2^2}{2}$$

$$h_1 - h_2 = \frac{V_2^2 - V_1^2}{2}$$

$$c_p (T_1 - T_2) = \frac{V_2^2 - V_1^2}{2} = \Delta \text{ke}$$

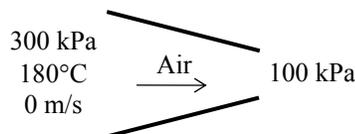

The kinetic energy change for the isentropic case is

$$\Delta \text{ke}_s = c_p (T_1 - T_{2s}) = (1.005 \text{ kJ/kg}\cdot\text{K})(453 - 331)\text{K} = 122.6 \text{ kJ/kg}$$

The kinetic energy change for the actual process is

$$\Delta \text{ke}_a = \eta_N \Delta \text{ke}_s = (0.96)(122.6 \text{ kJ/kg}) = 117.7 \text{ kJ/kg}$$

Substituting into the energy balance and solving for the exit velocity gives

$$V_2 = (2\Delta \text{ke}_a)^{0.5} = \left[2(117.7 \text{ kJ/kg}) \left(\frac{1000 \text{ m}^2/\text{s}^2}{1 \text{ kJ/kg}} \right) \right]^{0.5} = \mathbf{485 \text{ m/s}}$$

7-143E Air is decelerated in an adiabatic diffuser with an isentropic efficiency of 0.82. The air velocity at the exit is to be determined.

Assumptions 1 This is a steady-flow process since there is no change with time. **2** There is no heat transfer or shaft work associated with the process. **3** Air is an ideal gas with constant specific heats.

Properties The properties of air at room temperature are $c_p = 0.240$ Btu/lbm·R and $k = 1.4$ (Table A-2Ea).

Analysis For the isentropic process of an ideal gas, the exit temperature is determined from

$$T_{2s} = T_1 \left(\frac{P_2}{P_1} \right)^{(k-1)/k} = (30 + 460 \text{ R}) \left(\frac{20 \text{ psia}}{13 \text{ psia}} \right)^{0.4/1.4} = 554.2 \text{ R}$$

There is only one inlet and one exit, and thus $\dot{m}_1 = \dot{m}_2 = \dot{m}$. We take nozzle as the system, which is a control volume since mass crosses the boundary. The energy balance for this steady-flow system can be expressed in the rate form as

$$\underbrace{\dot{E}_{\text{in}} - \dot{E}_{\text{out}}}_{\text{Rate of net energy transfer by heat, work, and mass}} = \underbrace{\Delta \dot{E}_{\text{system}}^{\text{no}}}_{\text{Rate of change in internal, kinetic, potential, etc. energies (steady)}} = 0$$

$$\dot{E}_{\text{in}} = \dot{E}_{\text{out}}$$

$$\dot{m} \left(h_1 + \frac{V_1^2}{2} \right) = \dot{m} \left(h_2 + \frac{V_2^2}{2} \right)$$

$$h_1 + \frac{V_1^2}{2} = h_2 + \frac{V_2^2}{2}$$

$$h_1 - h_2 = \frac{V_2^2 - V_1^2}{2}$$

$$c_p (T_1 - T_2) = \frac{V_2^2 - V_1^2}{2} = \Delta \text{ke}$$

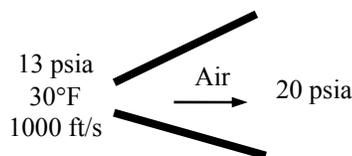

The kinetic energy change for the isentropic case is

$$\Delta \text{ke}_s = c_p (T_{2s} - T_1) = (0.240 \text{ Btu/lbm} \cdot \text{R})(554.2 - 490) \text{ R} = 15.41 \text{ Btu/lbm}$$

The kinetic energy change for the actual process is

$$\Delta \text{ke}_a = \eta_N \Delta \text{ke}_s = (0.82)(15.41 \text{ Btu/lbm}) = 12.63 \text{ Btu/lbm}$$

Substituting into the energy balance and solving for the exit velocity gives

$$V_2 = (V_1^2 - 2\Delta \text{ke}_a)^{0.5} = \left[(1000 \text{ ft/s})^2 - 2(12.63 \text{ Btu/lbm}) \left(\frac{25,037 \text{ ft}^2/\text{s}^2}{1 \text{ Btu/lbm}} \right) \right]^{0.5} = \mathbf{606 \text{ ft/s}}$$

Entropy Balance

7-144 Heat is lost from Refrigerant-134a as it is throttled. The exit temperature of the refrigerant and the entropy generation are to be determined.

Assumptions 1 Steady operating conditions exist. 2 Kinetic and potential energy changes are negligible.

Analysis The properties of the refrigerant at the inlet of the device are (Table A-13)

$$\left. \begin{array}{l} P_1 = 900 \text{ kPa} \\ T_1 = 35^\circ\text{C} \end{array} \right\} \begin{array}{l} h_1 = 100.86 \text{ kJ/kg} \\ s_1 = 0.37135 \text{ kJ/kg}\cdot\text{K} \end{array}$$

The enthalpy of the refrigerant at the exit of the device is

$$h_2 = h_1 - q_{\text{out}} = 100.86 - 0.8 = 100.06 \text{ kJ/kg}$$

Now, the properties at the exit state may be obtained from the R-134a tables

$$\left. \begin{array}{l} P_2 = 200 \text{ kPa} \\ h_2 = 100.06 \text{ kJ/kg} \end{array} \right\} \begin{array}{l} T_2 = -10.09^\circ\text{C} \\ s_2 = 0.38884 \text{ kJ/kg}\cdot\text{K} \end{array}$$

The entropy generation associated with this process may be obtained by adding the entropy change of R-134a as it flows in the device and the entropy change of the surroundings.

$$\Delta s_{\text{R-134a}} = s_2 - s_1 = 0.38884 - 0.37135 = 0.01749 \text{ kJ/kg}\cdot\text{K}$$

$$\Delta s_{\text{surr}} = \frac{q_{\text{out}}}{T_{\text{surr}}} = \frac{0.8 \text{ kJ/kg}}{(25 + 273) \text{ K}} = 0.002685 \text{ kJ/kg}\cdot\text{K}$$

$$s_{\text{gen}} = \Delta s_{\text{total}} = \Delta s_{\text{R-134a}} + \Delta s_{\text{surr}} = 0.01749 + 0.002685 = \mathbf{0.0202 \text{ kJ/kg}\cdot\text{K}}$$

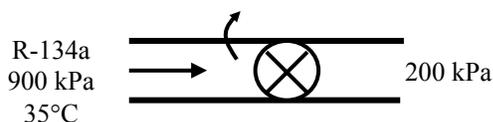

7-145 Liquid water is withdrawn from a rigid tank that initially contains saturated water mixture until no liquid is left in the tank. The quality of steam in the tank at the initial state, the amount of mass that has escaped, and the entropy generation during this process are to be determined.

Assumptions **1** Kinetic and potential energy changes are zero. **2** There are no work interactions.

Analysis (a) The properties of the steam in the tank at the final state and the properties of exiting steam are (Tables A-4 through A-6)

$$\left. \begin{array}{l} P_2 = 400 \text{ kPa} \\ x_2 = 1 \text{ (sat. vap.)} \end{array} \right\} \begin{array}{l} u_2 = 2553.1 \text{ kJ/kg} \\ v_2 = 0.46242 \text{ m}^3/\text{kg} \\ s_2 = 6.8955 \text{ kJ/kg}\cdot\text{K} \end{array}$$

$$\left. \begin{array}{l} P_{2e} = 400 \text{ kPa} \\ x_e = 0 \text{ (sat. liq.)} \end{array} \right\} \begin{array}{l} h_e = 604.66 \text{ kJ/kg} \\ s_e = 1.7765 \text{ kJ/kg}\cdot\text{K} \end{array}$$

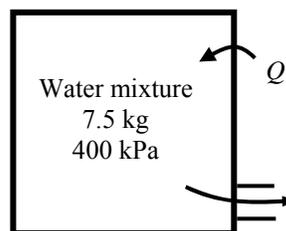

The relations for the volume of the tank and the final mass in the tank are

$$\begin{aligned} V &= m_1 v_1 = (7.5 \text{ kg})v_1 \\ m_2 &= \frac{V}{v_2} = \frac{(7.5 \text{ kg})v_1}{0.46242 \text{ m}^3/\text{kg}} = 16.219v_1 \end{aligned}$$

The mass, energy, and entropy balances may be written as

$$m_e = m_1 - m_2$$

$$Q_{\text{in}} - m_e h_e = m_2 u_2 - m_1 u_1$$

$$\frac{Q_{\text{in}}}{T_{\text{source}}} - m_e s_e + S_{\text{gen}} = m_2 s_2 - m_1 s_1$$

Substituting,

$$m_e = 7.5 - 16.219v_1 \quad (1)$$

$$5 - (7.5 - 16.219v_1)(604.66) = 16.219v_1(2553.1) - 7.5u_1 \quad (2)$$

$$\frac{5}{500 + 273} - (7.5 - 16.219v_1)(1.7765) + S_{\text{gen}} = 16.219v_1(6.8955) - 7.5s_1 \quad (3)$$

Eq. (2) may be solved by a trial-error approach by trying different qualities at the inlet state. Or, we can use EES to solve the equations to find

$$x_1 = \mathbf{0.8666}$$

Other properties at the initial state are

$$\left. \begin{array}{l} P_1 = 400 \text{ kPa} \\ x_1 = 0.8666 \end{array} \right\} \begin{array}{l} u_1 = 2293.2 \text{ kJ/kg} \\ v_1 = 0.40089 \text{ m}^3/\text{kg} \\ s_1 = 6.2129 \text{ kJ/kg}\cdot\text{K} \end{array}$$

Substituting into Eqs (1) and (3),

$$(b) \quad m_e = 7.5 - 16.219(0.40089) = \mathbf{0.998 \text{ kg}}$$

(c)

$$\frac{5}{500 + 273} - [7.5 - 16.219(0.40089)](1.7765) + S_{\text{gen}} = 16.219(0.40089)(6.8955) - 7.5(6.2129)$$

$$S_{\text{gen}} = \mathbf{0.00553 \text{ kJ/K}}$$

7-146 Each member of a family of four take a 5-min shower every day. The amount of entropy generated by this family per year is to be determined.

Assumptions **1** Steady operating conditions exist. **2** The kinetic and potential energies are negligible. **3** Heat losses from the pipes and the mixing section are negligible and thus $\dot{Q} \cong 0$. **4** Showers operate at maximum flow conditions during the entire shower. **5** Each member of the household takes a 5-min shower every day. **6** Water is an incompressible substance with constant properties at room temperature. **7** The efficiency of the electric water heater is 100%.

Properties The density and specific heat of water at room temperature are $\rho = 1 \text{ kg/L} = 1000 \text{ kg/m}^3$ and $c = 4.18 \text{ kJ/kg}\cdot^\circ\text{C}$ (Table A-3).

Analysis The mass flow rate of water at the shower head is

$$\dot{m} = \rho \dot{V} = (1 \text{ kg/L})(12 \text{ L/min}) = 12 \text{ kg/min}$$

The mass balance for the mixing chamber can be expressed in the rate form as

$$\begin{aligned} \dot{m}_{\text{in}} - \dot{m}_{\text{out}} &= \Delta \dot{m}_{\text{system}} \stackrel{\approx 0 \text{ (steady)}}{=} 0 \\ \dot{m}_{\text{in}} &= \dot{m}_{\text{out}} \longrightarrow \dot{m}_1 + \dot{m}_2 = \dot{m}_3 \end{aligned}$$

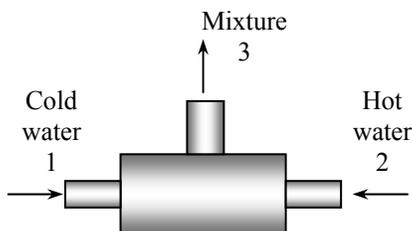

where the subscript 1 denotes the cold water stream, 2 the hot water stream, and 3 the mixture.

The rate of entropy generation during this process can be determined by applying the rate form of the entropy balance on a system that includes the electric water heater and the mixing chamber (the T-elbow). Noting that there is no entropy transfer associated with work transfer (electricity) and there is no heat transfer, the entropy balance for this steady-flow system can be expressed as

$$\begin{aligned} \underbrace{\dot{S}_{\text{in}} - \dot{S}_{\text{out}}}_{\text{Rate of net entropy transfer by heat and mass}} + \underbrace{\dot{S}_{\text{gen}}}_{\text{Rate of entropy generation}} &= \underbrace{\Delta \dot{S}_{\text{system}}}_{\text{Rate of change of entropy}} \stackrel{\approx 0 \text{ (steady)}}{=} 0 \\ \dot{m}_1 s_1 + \dot{m}_2 s_2 - \dot{m}_3 s_3 + \dot{S}_{\text{gen}} &= 0 \quad (\text{since } \dot{Q} = 0 \text{ and work is entropy free}) \\ \dot{S}_{\text{gen}} &= \dot{m}_3 s_3 - \dot{m}_1 s_1 - \dot{m}_2 s_2 \end{aligned}$$

Noting from mass balance that $\dot{m}_1 + \dot{m}_2 = \dot{m}_3$ and $s_2 = s_1$ since hot water enters the system at the same temperature as the cold water, the rate of entropy generation is determined to be

$$\begin{aligned} \dot{S}_{\text{gen}} &= \dot{m}_3 s_3 - (\dot{m}_1 + \dot{m}_2) s_1 = \dot{m}_3 (s_3 - s_1) = \dot{m}_3 c_p \ln \frac{T_3}{T_1} \\ &= (12 \text{ kg/min})(4.18 \text{ kJ/kg}\cdot\text{K}) \ln \frac{42 + 273}{15 + 273} = 4.495 \text{ kJ/min}\cdot\text{K} \end{aligned}$$

Noting that 4 people take a 5-min shower every day, the amount of entropy generated per year is

$$\begin{aligned} S_{\text{gen}} &= (\dot{S}_{\text{gen}}) \Delta t (\text{No. of people}) (\text{No. of days}) \\ &= (4.495 \text{ kJ/min}\cdot\text{K})(5 \text{ min/person}\cdot\text{day})(4 \text{ persons})(365 \text{ days/year}) \\ &= \mathbf{32,814 \text{ kJ/K}} \quad (\text{per year}) \end{aligned}$$

Discussion The value above represents the entropy generated within the water heater and the T-elbow in the absence of any heat losses. It does not include the entropy generated as the shower water at 42°C is discarded or cooled to the outdoor temperature. Also, an entropy balance on the mixing chamber alone (hot water entering at 55°C instead of 15°C) will exclude the entropy generated within the water heater.

7-147 Steam is condensed by cooling water in the condenser of a power plant. The rate of condensation of steam and the rate of entropy generation are to be determined.

Assumptions 1 Steady operating conditions exist. 2 The heat exchanger is well-insulated so that heat loss to the surroundings is negligible and thus heat transfer from the hot fluid is equal to the heat transfer to the cold fluid. 3 Changes in the kinetic and potential energies of fluid streams are negligible. 4 Fluid properties are constant.

Properties The enthalpy and entropy of vaporization of water at 60°C are $h_{fg} = 2357.7$ kJ/kg and $s_{fg} = 7.0769$ kJ/kg.K (Table A-4). The specific heat of water at room temperature is $c_p = 4.18$ kJ/kg.°C (Table A-3).

Analysis (a) We take the cold water tubes as the system, which is a control volume. The energy balance for this steady-flow system can be expressed in the rate form as

$$\underbrace{\dot{E}_{in} - \dot{E}_{out}}_{\text{Rate of net energy transfer by heat, work, and mass}} = \underbrace{\Delta \dot{E}_{system} \overset{\neq 0}{\text{(steady)}}}_{\text{Rate of change in internal, kinetic, potential, etc. energies}} = 0$$

$$\dot{E}_{in} = \dot{E}_{out}$$

$$\dot{Q}_{in} + \dot{m}h_1 = \dot{m}h_2 \quad (\text{since } \Delta ke \cong \Delta pe \cong 0)$$

$$\dot{Q}_{in} = \dot{m}c_p(T_2 - T_1)$$

Then the heat transfer rate to the cooling water in the condenser becomes

$$\dot{Q} = [\dot{m}c_p(T_{out} - T_{in})]_{\text{cooling water}}$$

$$= (75 \text{ kg/s})(4.18 \text{ kJ/kg}\cdot\text{°C})(27\text{°C} - 18\text{°C}) = 2822 \text{ kJ/s}$$

The rate of condensation of steam is determined to be

$$\dot{Q} = (\dot{m}h_{fg})_{\text{steam}} \longrightarrow \dot{m}_{\text{steam}} = \frac{\dot{Q}}{h_{fg}} = \frac{2822 \text{ kJ/s}}{2357.7 \text{ kJ/kg}} = \mathbf{1.20 \text{ kg/s}}$$

(b) The rate of entropy generation within the condenser during this process can be determined by applying the rate form of the entropy balance on the entire condenser. Noting that the condenser is well-insulated and thus heat transfer is negligible, the entropy balance for this steady-flow system can be expressed as

$$\underbrace{\dot{S}_{in} - \dot{S}_{out}}_{\text{Rate of net entropy transfer by heat and mass}} + \underbrace{\dot{S}_{gen}}_{\text{Rate of entropy generation}} = \underbrace{\Delta \dot{S}_{system} \overset{\neq 0}{\text{(steady)}}}_{\text{Rate of change of entropy}}$$

$$\dot{m}_1 s_1 + \dot{m}_3 s_3 - \dot{m}_2 s_2 - \dot{m}_4 s_4 + \dot{S}_{gen} = 0 \quad (\text{since } \dot{Q} = 0)$$

$$\dot{m}_{\text{water}} s_1 + \dot{m}_{\text{steam}} s_3 - \dot{m}_{\text{water}} s_2 - \dot{m}_{\text{steam}} s_4 + \dot{S}_{gen} = 0$$

$$\dot{S}_{gen} = \dot{m}_{\text{water}}(s_2 - s_1) + \dot{m}_{\text{steam}}(s_4 - s_3)$$

Noting that water is an incompressible substance and steam changes from saturated vapor to saturated liquid, the rate of entropy generation is determined to be

$$\dot{S}_{gen} = \dot{m}_{\text{water}} c_p \ln \frac{T_2}{T_1} + \dot{m}_{\text{steam}}(s_f - s_g) = \dot{m}_{\text{water}} c_p \ln \frac{T_2}{T_1} - \dot{m}_{\text{steam}} s_{fg}$$

$$= (75 \text{ kg/s})(4.18 \text{ kJ/kg}\cdot\text{K}) \ln \frac{27 + 273}{18 + 273} - (1.20 \text{ kg/s})(7.0769 \text{ kJ/kg}\cdot\text{K})$$

$$= \mathbf{1.06 \text{ kW/K}}$$

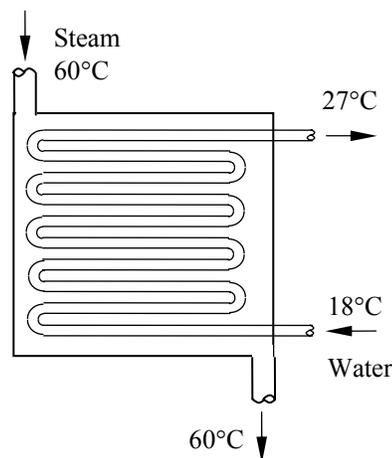

7-148 Cold water is heated by hot water in a heat exchanger. The rate of heat transfer and the rate of entropy generation within the heat exchanger are to be determined.

Assumptions 1 Steady operating conditions exist. **2** The heat exchanger is well-insulated so that heat loss to the surroundings is negligible and thus heat transfer from the hot fluid is equal to the heat transfer to the cold fluid. **3** Changes in the kinetic and potential energies of fluid streams are negligible. **4** Fluid properties are constant.

Properties The specific heats of cold and hot water are given to be 4.18 and 4.19 kJ/kg·°C, respectively.

Analysis We take the cold water tubes as the system, which is a control volume. The energy balance for this steady-flow system can be expressed in the rate form as

$$\underbrace{\dot{E}_{\text{in}} - \dot{E}_{\text{out}}}_{\text{Rate of net energy transfer by heat, work, and mass}} = \underbrace{\Delta \dot{E}_{\text{system}}}_{\text{Rate of change in internal, kinetic, potential, etc. energies}} \stackrel{\approx 0 \text{ (steady)}}{=} 0$$

$$\dot{E}_{\text{in}} = \dot{E}_{\text{out}}$$

$$\dot{Q}_{\text{in}} + \dot{m}h_1 = \dot{m}h_2 \quad (\text{since } \Delta ke \cong \Delta pe \cong 0)$$

$$\dot{Q}_{\text{in}} = \dot{m}c_p(T_2 - T_1)$$

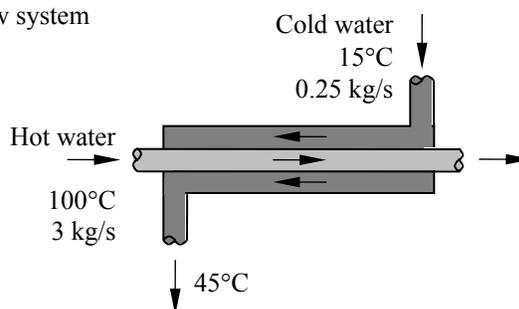

Then the rate of heat transfer to the cold water in this heat exchanger becomes

$$\dot{Q}_{\text{in}} = [\dot{m}c_p(T_{\text{out}} - T_{\text{in}})]_{\text{cold water}} = (0.25 \text{ kg/s})(4.18 \text{ kJ/kg}\cdot\text{°C})(45\text{°C} - 15\text{°C}) = \mathbf{31.35 \text{ kW}}$$

Noting that heat gain by the cold water is equal to the heat loss by the hot water, the outlet temperature of the hot water is determined to be

$$\dot{Q} = [\dot{m}c_p(T_{\text{in}} - T_{\text{out}})]_{\text{hot water}} \longrightarrow T_{\text{out}} = T_{\text{in}} - \frac{\dot{Q}}{\dot{m}c_p} = 100\text{°C} - \frac{31.35 \text{ kW}}{(3 \text{ kg/s})(4.19 \text{ kJ/kg}\cdot\text{°C})} = 97.5\text{°C}$$

(b) The rate of entropy generation within the heat exchanger is determined by applying the rate form of the entropy balance on the entire heat exchanger:

$$\underbrace{\dot{S}_{\text{in}} - \dot{S}_{\text{out}}}_{\text{Rate of net entropy transfer by heat and mass}} + \underbrace{\dot{S}_{\text{gen}}}_{\text{Rate of entropy generation}} = \underbrace{\Delta \dot{S}_{\text{system}}}_{\text{Rate of change of entropy}} \stackrel{\approx 0 \text{ (steady)}}{=} 0$$

$$\dot{m}_1 s_1 + \dot{m}_3 s_3 - \dot{m}_2 s_2 - \dot{m}_4 s_4 + \dot{S}_{\text{gen}} = 0 \quad (\text{since } \dot{Q} = 0)$$

$$\dot{m}_{\text{cold}} s_1 + \dot{m}_{\text{hot}} s_3 - \dot{m}_{\text{cold}} s_2 - \dot{m}_{\text{hot}} s_4 + \dot{S}_{\text{gen}} = 0$$

$$\dot{S}_{\text{gen}} = \dot{m}_{\text{cold}}(s_2 - s_1) + \dot{m}_{\text{hot}}(s_4 - s_3)$$

Noting that both fluid streams are liquids (incompressible substances), the rate of entropy generation is determined to be

$$\dot{S}_{\text{gen}} = \dot{m}_{\text{cold}} c_p \ln \frac{T_2}{T_1} + \dot{m}_{\text{hot}} c_p \ln \frac{T_4}{T_3}$$

$$= (0.25 \text{ kg/s})(4.18 \text{ kJ/kg}\cdot\text{K}) \ln \frac{45 + 273}{15 + 273} + (3 \text{ kg/s})(4.19 \text{ kJ/kg}\cdot\text{K}) \ln \frac{97.5 + 273}{100 + 273}$$

$$= \mathbf{0.0190 \text{ kW/K}}$$

7-149 Air is preheated by hot exhaust gases in a cross-flow heat exchanger. The rate of heat transfer, the outlet temperature of the air, and the rate of entropy generation are to be determined.

Assumptions 1 Steady operating conditions exist. 2 The heat exchanger is well-insulated so that heat loss to the surroundings is negligible and thus heat transfer from the hot fluid is equal to the heat transfer to the cold fluid. 3 Changes in the kinetic and potential energies of fluid streams are negligible. 4 Fluid properties are constant.

Properties The specific heats of air and combustion gases are given to be 1.005 and 1.10 kJ/kg·°C, respectively. The gas constant of air is $R = 0.287$ kJ/kg·K (Table A-1).

Analysis We take the exhaust pipes as the system, which is a control volume. The energy balance for this steady-flow system can be expressed in the rate form as

$$\underbrace{\dot{E}_{\text{in}} - \dot{E}_{\text{out}}}_{\text{Rate of net energy transfer by heat, work, and mass}} = \underbrace{\Delta \dot{E}_{\text{system}}}_{\substack{\neq 0 \text{ (steady)}}}_{\text{Rate of change in internal, kinetic, potential, etc. energies}} = 0$$

$$\dot{E}_{\text{in}} = \dot{E}_{\text{out}}$$

$$\dot{m}h_1 = \dot{Q}_{\text{out}} + \dot{m}h_2 \quad (\text{since } \Delta ke \cong \Delta pe \cong 0)$$

$$\dot{Q}_{\text{out}} = \dot{m}c_p(T_1 - T_2)$$

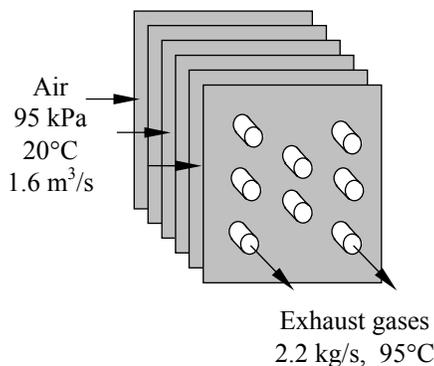

Then the rate of heat transfer from the exhaust gases becomes

$$\dot{Q} = [\dot{m}c_p(T_{\text{in}} - T_{\text{out}})]_{\text{gas}} = (2.2 \text{ kg/s})(1.1 \text{ kJ/kg}\cdot^\circ\text{C})(180^\circ\text{C} - 95^\circ\text{C}) = \mathbf{205.7 \text{ kW}}$$

The mass flow rate of air is

$$\dot{m} = \frac{P\dot{V}}{RT} = \frac{(95 \text{ kPa})(1.6 \text{ m}^3/\text{s})}{(0.287 \text{ kPa}\cdot\text{m}^3/\text{kg}\cdot\text{K})(293 \text{ K})} = 1.808 \text{ kg/s}$$

Noting that heat loss by the exhaust gases is equal to the heat gain by the air, the outlet temperature of the air becomes

$$\dot{Q} = [\dot{m}c_p(T_{\text{out}} - T_{\text{in}})]_{\text{air}} \longrightarrow T_{\text{out}} = T_{\text{in}} + \frac{\dot{Q}}{\dot{m}c_p} = 20^\circ\text{C} + \frac{205.7 \text{ kW}}{(1.808 \text{ kg/s})(1.005 \text{ kJ/kg}\cdot^\circ\text{C})} = \mathbf{133.2^\circ\text{C}}$$

The rate of entropy generation within the heat exchanger is determined by applying the rate form of the entropy balance on the entire heat exchanger:

$$\underbrace{\dot{S}_{\text{in}} - \dot{S}_{\text{out}}}_{\substack{\text{Rate of net entropy transfer} \\ \text{by heat and mass}}} + \underbrace{\dot{S}_{\text{gen}}}_{\substack{\text{Rate of entropy} \\ \text{generation}}} = \underbrace{\Delta \dot{S}_{\text{system}}}_{\substack{\neq 0 \text{ (steady)}}}_{\substack{\text{Rate of change} \\ \text{of entropy}}}$$

$$\dot{m}_1 s_1 + \dot{m}_3 s_3 - \dot{m}_2 s_2 - \dot{m}_4 s_4 + \dot{S}_{\text{gen}} = 0 \quad (\text{since } \dot{Q} = 0)$$

$$\dot{m}_{\text{exhaust}} s_1 + \dot{m}_{\text{air}} s_3 - \dot{m}_{\text{exhaust}} s_2 - \dot{m}_{\text{air}} s_4 + \dot{S}_{\text{gen}} = 0$$

$$\dot{S}_{\text{gen}} = \dot{m}_{\text{exhaust}}(s_2 - s_1) + \dot{m}_{\text{air}}(s_4 - s_3)$$

Then the rate of entropy generation is determined to be

$$\begin{aligned} \dot{S}_{\text{gen}} &= \dot{m}_{\text{exhaust}} c_p \ln \frac{T_2}{T_1} + \dot{m}_{\text{air}} c_p \ln \frac{T_4}{T_3} \\ &= (2.2 \text{ kg/s})(1.1 \text{ kJ/kg}\cdot\text{K}) \ln \frac{95 + 273}{180 + 273} + (1.808 \text{ kg/s})(1.005 \text{ kJ/kg}\cdot\text{K}) \ln \frac{133.2 + 273}{20 + 273} \\ &= \mathbf{0.091 \text{ kW/K}} \end{aligned}$$

7-150 Water is heated by hot oil in a heat exchanger. The outlet temperature of the oil and the rate of entropy generation within the heat exchanger are to be determined.

Assumptions 1 Steady operating conditions exist. 2 The heat exchanger is well-insulated so that heat loss to the surroundings is negligible and thus heat transfer from the hot fluid is equal to the heat transfer to the cold fluid. 3 Changes in the kinetic and potential energies of fluid streams are negligible. 4 Fluid properties are constant.

Properties The specific heats of water and oil are given to be 4.18 and 2.3 kJ/kg·°C, respectively.

Analysis (a) We take the cold water tubes as the system, which is a control volume. The energy balance for this steady-flow system can be expressed in the rate form as

$$\underbrace{\dot{E}_{\text{in}} - \dot{E}_{\text{out}}}_{\text{Rate of net energy transfer by heat, work, and mass}} = \underbrace{\Delta \dot{E}_{\text{system}}}_{\text{Rate of change in internal, kinetic, potential, etc. energies}} \stackrel{\text{no (steady)}}{=} 0$$

$$\dot{E}_{\text{in}} = \dot{E}_{\text{out}}$$

$$\dot{Q}_{\text{in}} + \dot{m}h_1 = \dot{m}h_2 \quad (\text{since } \Delta ke \cong \Delta pe \cong 0)$$

$$\dot{Q}_{\text{in}} = \dot{m}c_p(T_2 - T_1)$$

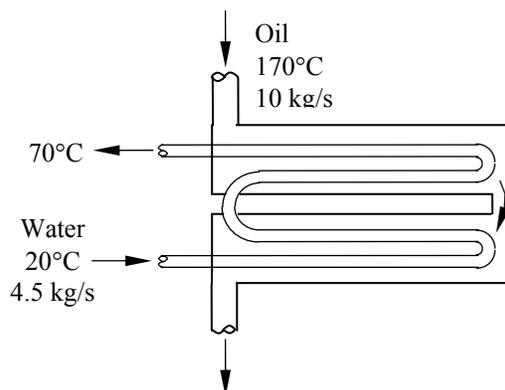

Then the rate of heat transfer to the cold water in this heat exchanger becomes

$$\dot{Q} = [\dot{m}c_p(T_{\text{out}} - T_{\text{in}})]_{\text{water}} = (4.5 \text{ kg/s})(4.18 \text{ kJ/kg}\cdot\text{°C})(70\text{°C} - 20\text{°C}) = 940.5 \text{ kW}$$

Noting that heat gain by the water is equal to the heat loss by the oil, the outlet temperature of the hot oil is determined from

$$\dot{Q} = [\dot{m}c_p(T_{\text{in}} - T_{\text{out}})]_{\text{oil}} \rightarrow T_{\text{out}} = T_{\text{in}} - \frac{\dot{Q}}{\dot{m}c_p} = 170\text{°C} - \frac{940.5 \text{ kW}}{(10 \text{ kg/s})(2.3 \text{ kJ/kg}\cdot\text{°C})} = \mathbf{129.1\text{°C}}$$

(b) The rate of entropy generation within the heat exchanger is determined by applying the rate form of the entropy balance on the entire heat exchanger:

$$\underbrace{\dot{S}_{\text{in}} - \dot{S}_{\text{out}}}_{\text{Rate of net entropy transfer by heat and mass}} + \underbrace{\dot{S}_{\text{gen}}}_{\text{Rate of entropy generation}} = \underbrace{\Delta \dot{S}_{\text{system}}}_{\text{Rate of change of entropy}} \stackrel{\text{no (steady)}}{=} 0$$

$$\dot{m}_1s_1 + \dot{m}_3s_3 - \dot{m}_2s_2 - \dot{m}_4s_4 + \dot{S}_{\text{gen}} = 0 \quad (\text{since } \dot{Q} = 0)$$

$$\dot{m}_{\text{water}}s_1 + \dot{m}_{\text{oil}}s_3 - \dot{m}_{\text{water}}s_2 - \dot{m}_{\text{oil}}s_4 + \dot{S}_{\text{gen}} = 0$$

$$\dot{S}_{\text{gen}} = \dot{m}_{\text{water}}(s_2 - s_1) + \dot{m}_{\text{oil}}(s_4 - s_3)$$

Noting that both fluid streams are liquids (incompressible substances), the rate of entropy generation is determined to be

$$\dot{S}_{\text{gen}} = \dot{m}_{\text{water}}c_p \ln \frac{T_2}{T_1} + \dot{m}_{\text{oil}}c_p \ln \frac{T_4}{T_3}$$

$$= (4.5 \text{ kg/s})(4.18 \text{ kJ/kg}\cdot\text{K}) \ln \frac{70 + 273}{20 + 273} + (10 \text{ kg/s})(2.3 \text{ kJ/kg}\cdot\text{K}) \ln \frac{129.1 + 273}{170 + 273}$$

$$= \mathbf{0.736 \text{ kW/K}}$$

7-151E Refrigerant-134a is expanded adiabatically from a specified state to another. The entropy generation is to be determined.

Assumptions 1 Steady operating conditions exist. 2 Kinetic and potential energy changes are negligible.

Analysis The rate of entropy generation within the expansion device during this process can be determined by applying the rate form of the entropy balance on the system. Noting that the system is adiabatic and thus there is no heat transfer, the entropy balance for this steady-flow system can be expressed as

$$\underbrace{\dot{S}_{\text{in}} - \dot{S}_{\text{out}}}_{\text{Rate of net entropy transfer by heat and mass}} + \underbrace{\dot{S}_{\text{gen}}}_{\text{Rate of entropy generation}} = \underbrace{\Delta \dot{S}_{\text{system}}}_{\text{Rate of change of entropy}} \stackrel{\neq 0 \text{ (steady)}}{=} 0$$

$$\dot{m}_1 s_1 - \dot{m}_2 s_2 + \dot{S}_{\text{gen}} = 0$$

$$\dot{S}_{\text{gen}} = \dot{m}(s_2 - s_1)$$

$$s_{\text{gen}} = s_2 - s_1$$

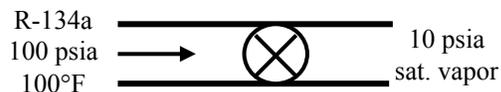

The properties of the refrigerant at the inlet and exit states are (Tables A-11E through A-13E)

$$\left. \begin{array}{l} P_1 = 100 \text{ psia} \\ T_1 = 100^\circ\text{F} \end{array} \right\} s_1 = 0.22900 \text{ Btu/lbm} \cdot \text{R}$$

$$\left. \begin{array}{l} P_2 = 10 \text{ psia} \\ x_2 = 1 \end{array} \right\} s_2 = 0.22948 \text{ Btu/lbm} \cdot \text{R}$$

Substituting,

$$s_{\text{gen}} = s_2 - s_1 = 0.22948 - 0.22900 = \mathbf{0.00048 \text{ Btu/lbm} \cdot \text{R}}$$

7-152 In an ice-making plant, water is frozen by evaporating saturated R-134a liquid. The rate of entropy generation is to be determined.

Assumptions 1 Steady operating conditions exist. 2 Kinetic and potential energy changes are negligible.

Analysis We take the control volume formed by the R-134a evaporator with a single inlet and single exit as the system. The rate of entropy generation within this evaporator during this process can be determined by applying the rate form of the entropy balance on the system. The entropy balance for this steady-flow system can be expressed as

$$\underbrace{\dot{S}_{\text{in}} - \dot{S}_{\text{out}}}_{\text{Rate of net entropy transfer by heat and mass}} + \underbrace{\dot{S}_{\text{gen}}}_{\text{Rate of entropy generation}} = \underbrace{\Delta\dot{S}_{\text{system}}}_{\text{Rate of change of entropy}} \overset{\neq 0 \text{ (steady)}}{}$$

$$\dot{m}_1 s_1 - \dot{m}_2 s_2 + \frac{\dot{Q}_{\text{in}}}{T_w} + \dot{S}_{\text{gen}} = 0$$

$$\dot{S}_{\text{gen}} = \dot{m}_R (s_2 - s_1) - \frac{\dot{Q}_{\text{in}}}{T_w}$$

$$\dot{S}_{\text{gen}} = \dot{m}_R s_{fg} - \frac{\dot{Q}_{\text{in}}}{T_w}$$



The properties of the refrigerant are (Table A-11)

$$h_{fg @ -10^\circ\text{C}} = 205.96 \text{ kJ/kg}$$

$$s_{fg @ -10^\circ\text{C}} = 0.78263 \text{ kJ/kg} \cdot \text{K}$$

The rate of that must be removed from the water in order to freeze it at a rate of 4000 kg/h is

$$\dot{Q}_{\text{in}} = \dot{m}_w h_{if} = (4000 / 3600 \text{ kg/s})(333.7 \text{ kJ/kg}) = 370.8 \text{ kW}$$

where the heat of fusion of water at 1 atm is 333.7 kJ/kg. The mass flow rate of R-134a is

$$\dot{m}_R = \frac{\dot{Q}_{\text{in}}}{h_{fg}} = \frac{370.8 \text{ kJ/s}}{205.96 \text{ kJ/kg}} = 1.800 \text{ kg/s}$$

Substituting,

$$\dot{S}_{\text{gen}} = \dot{m}_R s_{fg} - \frac{\dot{Q}_{\text{in}}}{T_w} = (1.800 \text{ kg/s})(0.78263 \text{ kJ/kg} \cdot \text{K}) - \frac{370.8 \text{ kW}}{273 \text{ K}} = \mathbf{0.0505 \text{ kW/K}}$$

7-153 Air is heated by steam in a heat exchanger. The rate of entropy generation associated with this process is to be determined.

Assumptions 1 Steady operating conditions exist. 2 The heat exchanger is well-insulated so that heat loss to the surroundings is negligible and thus heat transfer from the hot fluid is equal to the heat transfer to the cold fluid. 3 Changes in the kinetic and potential energies of fluid streams are negligible. 4 Air is an ideal gas with constant specific heats.

Properties The specific heat of air at room temperature is $c_p = 1.005 \text{ kJ/kg}\cdot^\circ\text{C}$ (Table A-2).

Analysis The rate of entropy generation within the heat exchanger is determined by applying the rate form of the entropy balance on the entire heat exchanger:

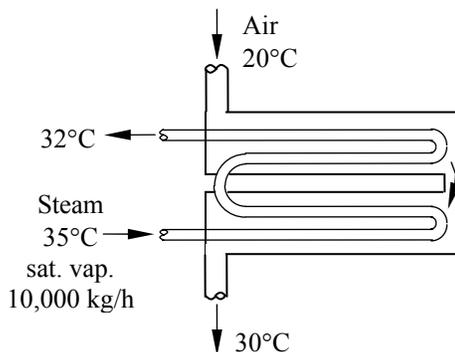

$$\underbrace{\dot{S}_{\text{in}} - \dot{S}_{\text{out}}}_{\text{Rate of net entropy transfer by heat and mass}} + \underbrace{\dot{S}_{\text{gen}}}_{\text{Rate of entropy generation}} = \underbrace{\Delta\dot{S}_{\text{system}}}_{\text{Rate of change of entropy}} \stackrel{\phi^0(\text{steady})}{=}$$

$$\dot{m}_{\text{water}}s_1 + \dot{m}_{\text{air}}s_3 - \dot{m}_{\text{water}}s_2 - \dot{m}_{\text{air}}s_4 + \dot{S}_{\text{gen}} = 0$$

$$\dot{S}_{\text{gen}} = \dot{m}_{\text{water}}(s_2 - s_1) + \dot{m}_{\text{air}}(s_4 - s_3)$$

The properties of the steam at the inlet and exit states are

$$\left. \begin{array}{l} T_1 = 35^\circ\text{C} \\ x_1 = 1 \end{array} \right\} \begin{array}{l} h_1 = 2564.6 \text{ kJ/kg} \\ s_1 = 8.3517 \text{ kJ/kg}\cdot\text{K} \end{array} \quad (\text{Table A-4})$$

$$\left. \begin{array}{l} T_2 = 32^\circ\text{C} \\ x_2 = 0 \end{array} \right\} \begin{array}{l} h_2 = 134.10 \text{ kJ/kg} \\ s_2 = 0.4641 \text{ kJ/kg}\cdot\text{K} \end{array} \quad (\text{Table A-4})$$

From an energy balance, the heat given up by steam is equal to the heat picked up by the air. Then,

$$\dot{Q} = \dot{m}_{\text{water}}(h_1 - h_2) = (10,000 / 3600 \text{ kg/s})(2564.6 - 134.10) \text{ kJ/kg} = 6751 \text{ kW}$$

$$\dot{m}_{\text{air}} = \frac{\dot{Q}}{c_p(T_4 - T_3)} = \frac{6751 \text{ kW}}{(1.005 \text{ kJ/kg}\cdot^\circ\text{C})(30 - 20)^\circ\text{C}} = 671.7 \text{ kg/s}$$

Substituting into the entropy balance relation,

$$\begin{aligned} \dot{S}_{\text{gen}} &= \dot{m}_{\text{water}}(s_2 - s_1) + \dot{m}_{\text{air}}(s_4 - s_3) \\ &= \dot{m}_{\text{water}}(s_2 - s_1) + \dot{m}_{\text{air}}c_p \ln \frac{T_4}{T_3} \\ &= (10,000 / 3600 \text{ kg/s})(0.4641 - 8.3517) \text{ kJ/kg}\cdot\text{K} + (671.7 \text{ kg/s})(1.005 \text{ kJ/kg}\cdot\text{K}) \ln \frac{303 \text{ K}}{293 \text{ K}} \\ &= \mathbf{0.745 \text{ kW/K}} \end{aligned}$$

Note that the pressure of air remains unchanged as it flows in the heat exchanger. This is why the pressure term is not included in the entropy change expression of air.

7-154 Oxygen is cooled as it flows in an insulated pipe. The rate of entropy generation in the pipe is to be determined.

Assumptions **1** Steady operating conditions exist. **2** The pipe is well-insulated so that heat loss to the surroundings is negligible. **3** Changes in the kinetic and potential energies are negligible. **4** Oxygen is an ideal gas with constant specific heats.

Properties The properties of oxygen at room temperature are $R = 0.2598 \text{ kJ/kg}\cdot\text{K}$, $c_p = 0.918 \text{ kJ/kg}\cdot\text{K}$ (Table A-2a).

Analysis The rate of entropy generation in the pipe is determined by applying the rate form of the entropy balance on the pipe:

$$\underbrace{\dot{S}_{\text{in}} - \dot{S}_{\text{out}}}_{\text{Rate of net entropy transfer by heat and mass}} + \underbrace{\dot{S}_{\text{gen}}}_{\text{Rate of entropy generation}} = \underbrace{\Delta\dot{S}_{\text{system}}}_{\text{Rate of change of entropy}} \stackrel{\neq 0 \text{ (steady)}}{=} 0$$

$$\dot{m}_1 s_1 - \dot{m}_2 s_2 + \dot{S}_{\text{gen}} = 0 \quad (\text{since } Q = 0)$$

$$\dot{S}_{\text{gen}} = \dot{m}(s_2 - s_1)$$

Oxygen

240 kPa

20°C

70 m/s

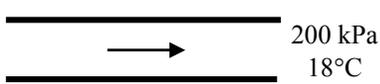

The specific volume of oxygen at the inlet and the mass flow rate are

$$\nu_1 = \frac{RT_1}{P_1} = \frac{(0.2598 \text{ kPa}\cdot\text{m}^3/\text{kg}\cdot\text{K})(293 \text{ K})}{240 \text{ kPa}} = 0.3172 \text{ m}^3/\text{kg}$$

$$\dot{m} = \frac{A_1 V_1}{\nu_1} = \frac{\pi D^2 V_1}{4 \nu_1} = \frac{\pi (0.12 \text{ m})^2 (70 \text{ m/s})}{4 (0.3172 \text{ m}^3/\text{kg})} = 2.496 \text{ kg/s}$$

Substituting into the entropy balance relation,

$$\begin{aligned} \dot{S}_{\text{gen}} &= \dot{m}(s_2 - s_1) \\ &= \dot{m} \left(c_p \ln \frac{T_2}{T_1} - R \ln \frac{P_2}{P_1} \right) \\ &= (2.496 \text{ kg/s}) \left[(0.918 \text{ kJ/kg}\cdot\text{K}) \ln \frac{291 \text{ K}}{293 \text{ K}} - (0.2598 \text{ kJ/kg}\cdot\text{K}) \ln \frac{200 \text{ kPa}}{240 \text{ kPa}} \right] \\ &= \mathbf{0.1025 \text{ kW/K}} \end{aligned}$$

7-155 Nitrogen is compressed by an adiabatic compressor. The entropy generation for this process is to be determined.

Assumptions **1** Steady operating conditions exist. **2** The compressor is well-insulated so that heat loss to the surroundings is negligible. **3** Changes in the kinetic and potential energies are negligible. **4** Nitrogen is an ideal gas with constant specific heats.

Properties The specific heat of nitrogen at the average temperature of $(17+227)/2=122^\circ\text{C} = 395\text{ K}$ is $c_p = 1.044\text{ kJ/kg}\cdot\text{K}$ (Table A-2b).

Analysis The rate of entropy generation in the pipe is determined by applying the rate form of the entropy balance on the compressor:

$$\underbrace{\dot{S}_{\text{in}} - \dot{S}_{\text{out}}}_{\text{Rate of net entropy transfer by heat and mass}} + \underbrace{\dot{S}_{\text{gen}}}_{\text{Rate of entropy generation}} = \underbrace{\Delta\dot{S}_{\text{system}}}_{\text{Rate of change of entropy}} \stackrel{\neq 0}{\text{(steady)}}$$

$$\dot{m}_1 s_1 - \dot{m}_2 s_2 + \dot{S}_{\text{gen}} = 0 \quad (\text{since } Q = 0)$$

$$\dot{S}_{\text{gen}} = \dot{m}(s_2 - s_1)$$

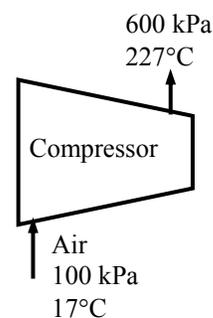

Substituting per unit mass of the oxygen,

$$s_{\text{gen}} = s_2 - s_1$$

$$= c_p \ln \frac{T_2}{T_1} - R \ln \frac{P_2}{P_1}$$

$$= (1.044\text{ kJ/kg}\cdot\text{K}) \ln \frac{(227 + 273)\text{ K}}{(17 + 273)\text{ K}} - (0.2968\text{ kJ/kg}\cdot\text{K}) \ln \frac{600\text{ kPa}}{100\text{ kPa}}$$

$$= \mathbf{0.0369\text{ kJ/kg}\cdot\text{K}}$$

7-156E Steam is condensed by cooling water in a condenser. The rate of heat transfer and the rate of entropy generation within the heat exchanger are to be determined.

Assumptions 1 Steady operating conditions exist. 2 The heat exchanger is well-insulated so that heat loss to the surroundings is negligible and thus heat transfer from the hot fluid is equal to the heat transfer to the cold fluid. 3 Changes in the kinetic and potential energies of fluid streams are negligible. 4 Fluid properties are constant.

Properties The specific heat of water is 1.0 Btu/lbm·°F (Table A-3E). The enthalpy and entropy of vaporization of water at 120°F are 1025.2 Btu/lbm and $s_{fg} = 1.7686$ Btu/lbm·R (Table A-4E).

Analysis We take the tube-side of the heat exchanger where cold water is flowing as the system, which is a control volume. The energy balance for this steady-flow system can be expressed in the rate form as

$$\underbrace{\dot{E}_{in} - \dot{E}_{out}}_{\text{Rate of net energy transfer by heat, work, and mass}} = \underbrace{\Delta \dot{E}_{system}^{\approx 0} \text{ (steady)}}_{\text{Rate of change in internal, kinetic, potential, etc. energies}} = 0$$

$$\dot{E}_{in} = \dot{E}_{out}$$

$$\dot{Q}_{in} + \dot{m}h_1 = \dot{m}h_2 \quad (\text{since } \Delta ke \cong \Delta pe \cong 0)$$

$$\dot{Q}_{in} = \dot{m}c_p(T_2 - T_1)$$

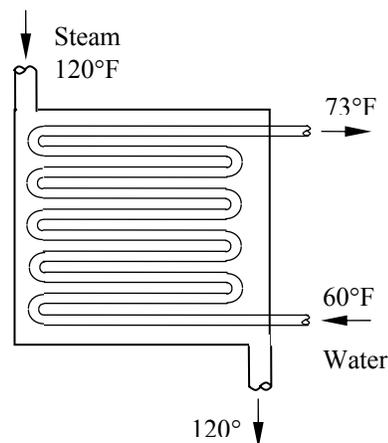

Then the rate of heat transfer to the cold water in this heat exchanger becomes

$$\dot{Q} = [\dot{m}c_p(T_{out} - T_{in})]_{\text{water}} = (92 \text{ lbm/s})(1.0 \text{ Btu/lbm}\cdot\text{°F})(73\text{°F} - 60\text{°F}) = \mathbf{1196 \text{ Btu/s}}$$

Noting that heat gain by the water is equal to the heat loss by the condensing steam, the rate of condensation of the steam in the heat exchanger is determined from

$$\dot{Q} = (\dot{m}h_{fg})_{\text{steam}} = \dot{m}_{\text{steam}} h_{fg} = \frac{1196 \text{ Btu/s}}{1025.2 \text{ Btu/lbm}} = 1.167 \text{ lbm/s}$$

(b) The rate of entropy generation within the heat exchanger is determined by applying the rate form of the entropy balance on the entire heat exchanger:

$$\underbrace{\dot{S}_{in} - \dot{S}_{out}}_{\text{Rate of net entropy transfer by heat and mass}} + \underbrace{\dot{S}_{gen}}_{\text{Rate of entropy generation}} = \underbrace{\Delta \dot{S}_{system}^{\approx 0} \text{ (steady)}}_{\text{Rate of change of entropy}}$$

$$\dot{m}_1 s_1 + \dot{m}_3 s_3 - \dot{m}_2 s_2 - \dot{m}_4 s_4 + \dot{S}_{gen} = 0 \quad (\text{since } \dot{Q} = 0)$$

$$\dot{m}_{\text{water}} s_1 + \dot{m}_{\text{steam}} s_3 - \dot{m}_{\text{water}} s_2 - \dot{m}_{\text{steam}} s_4 + \dot{S}_{gen} = 0$$

$$\dot{S}_{gen} = \dot{m}_{\text{water}}(s_2 - s_1) + \dot{m}_{\text{steam}}(s_4 - s_3)$$

Noting that water is an incompressible substance and steam changes from saturated vapor to saturated liquid, the rate of entropy generation is determined to be

$$\dot{S}_{gen} = \dot{m}_{\text{water}} c_p \ln \frac{T_2}{T_1} + \dot{m}_{\text{steam}}(s_f - s_g) = \dot{m}_{\text{water}} c_p \ln \frac{T_2}{T_1} - \dot{m}_{\text{steam}} s_{fg}$$

$$= (92 \text{ lbm/s})(1.0 \text{ Btu/lbm}\cdot\text{R}) \ln \frac{73 + 460}{60 + 460} - (1.167 \text{ lbm/s})(17686 \text{ Btu/lbm}\cdot\text{R})$$

$$= \mathbf{0.209 \text{ Btu/s}\cdot\text{R}}$$

7-157 A regenerator is considered to save heat during the cooling of milk in a dairy plant. The amounts of fuel and money such a generator will save per year and the annual reduction in the rate of entropy generation are to be determined.

Assumptions 1 Steady operating conditions exist. **2** The properties of the milk are constant.

Properties The average density and specific heat of milk can be taken to be $\rho_{\text{milk}} \cong \rho_{\text{water}} = 1 \text{ kg/L}$ and $c_{p, \text{milk}} = 3.79 \text{ kJ/kg} \cdot ^\circ\text{C}$ (Table A-3).

Analysis The mass flow rate of the milk is

$$\begin{aligned}\dot{m}_{\text{milk}} &= \rho \dot{V}_{\text{milk}} \\ &= (1 \text{ kg/L})(12 \text{ L/s}) = 12 \text{ kg/s} = 43,200 \text{ kg/h}\end{aligned}$$

Taking the pasteurizing section as the system, the energy balance for this steady-flow system can be expressed in the rate form as

$$\underbrace{\dot{E}_{\text{in}} - \dot{E}_{\text{out}}}_{\text{Rate of net energy transfer by heat, work, and mass}} = \underbrace{\Delta \dot{E}_{\text{system}}}_{\text{Rate of change in internal, kinetic, potential, etc. energies}} \stackrel{\text{no (steady)}}{=} 0 \rightarrow \dot{E}_{\text{in}} = \dot{E}_{\text{out}}$$

$$\dot{Q}_{\text{in}} + \dot{m}h_1 = \dot{m}h_2 \quad (\text{since } \Delta \text{ke} \cong \Delta \text{pe} \cong 0)$$

$$\dot{Q}_{\text{in}} = \dot{m}_{\text{milk}} c_p (T_2 - T_1)$$

Therefore, to heat the milk from 4 to 72°C as being done currently, heat must be transferred to the milk at a rate of

$$\dot{Q}_{\text{current}} = [\dot{m} c_p (T_{\text{pasteurization}} - T_{\text{refrigeration}})]_{\text{milk}} = (12 \text{ kg/s})(3.79 \text{ kJ/kg} \cdot ^\circ\text{C})(72 - 4)^\circ\text{C} = 3093 \text{ kJ/s}$$

The proposed regenerator has an effectiveness of $\varepsilon = 0.82$, and thus it will save 82 percent of this energy. Therefore,

$$\dot{Q}_{\text{saved}} = \varepsilon \dot{Q}_{\text{current}} = (0.82)(3093 \text{ kJ/s}) = 2536 \text{ kJ/s}$$

Noting that the boiler has an efficiency of $\eta_{\text{boiler}} = 0.82$, the energy savings above correspond to fuel savings of

$$\text{Fuel Saved} = \frac{\dot{Q}_{\text{saved}}}{\eta_{\text{boiler}}} = \frac{(2536 \text{ kJ/s})}{(0.82)} \frac{(1 \text{ therm})}{(105,500 \text{ kJ})} = 0.02931 \text{ therm/s}$$

Noting that 1 year = 365×24=8760 h and unit cost of natural gas is \$0.52/therm, the annual fuel and money savings will be

$$\text{Fuel Saved} = (0.02931 \text{ therms/s})(8760 \times 3600 \text{ s}) = \mathbf{924,450 \text{ therms/yr}}$$

$$\text{Money saved} = (\text{Fuel saved})(\text{Unit cost of fuel}) = (924,450 \text{ therm/yr})(\$1.04/\text{therm}) = \mathbf{\$961,400/\text{yr}}$$

The rate of entropy generation during this process is determined by applying the rate form of the entropy balance on an *extended system* that includes the regenerator and the immediate surroundings so that the boundary temperature is the surroundings temperature, which we take to be the cold water temperature of 18°C.:

$$\underbrace{\dot{S}_{\text{in}} - \dot{S}_{\text{out}}}_{\text{Rate of net entropy transfer by heat and mass}} + \underbrace{\dot{S}_{\text{gen}}}_{\text{Rate of entropy generation}} = \underbrace{\Delta \dot{S}_{\text{system}}}_{\text{Rate of change of entropy}} \stackrel{\text{no (steady)}}{=} 0 \rightarrow \dot{S}_{\text{gen}} = \dot{S}_{\text{out}} - \dot{S}_{\text{in}}$$

Disregarding entropy transfer associated with fuel flow, the only significant difference between the two cases is the reduction in the entropy transfer to water due to the reduction in heat transfer to water, and is determined to be

$$\dot{S}_{\text{gen, reduction}} = \dot{S}_{\text{out, reduction}} = \frac{\dot{Q}_{\text{out, reduction}}}{T_{\text{surr}}} = \frac{\dot{Q}_{\text{saved}}}{T_{\text{surr}}} = \frac{2536 \text{ kJ/s}}{18 + 273} = 8.715 \text{ kW/K}$$

$$S_{\text{gen, reduction}} = \dot{S}_{\text{gen, reduction}} \Delta t = (8.715 \text{ kJ/s} \cdot \text{K})(8760 \times 3600 \text{ s/year}) = \mathbf{2.75 \times 10^8 \text{ kJ/K}} \text{ (per year)}$$

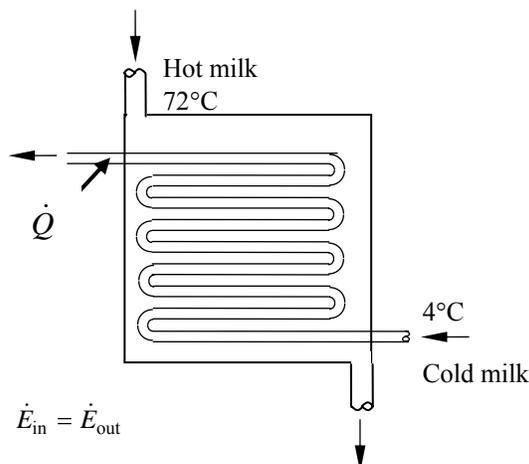

7-158 Stainless steel ball bearings leaving the oven at a uniform temperature of 900°C at a rate of 1400 /min are exposed to air and are cooled to 850°C before they are dropped into the water for quenching. The rate of heat transfer from the ball to the air and the rate of entropy generation due to this heat transfer are to be determined.

Assumptions **1** The thermal properties of the bearing balls are constant. **2** The kinetic and potential energy changes of the balls are negligible. **3** The balls are at a uniform temperature at the end of the process

Properties The density and specific heat of the ball bearings are given to be $\rho = 8085 \text{ kg/m}^3$ and $c_p = 0.480 \text{ kJ/kg}\cdot^\circ\text{C}$.

Analysis (a) We take a single bearing ball as the system. The energy balance for this closed system can be expressed as

$$\underbrace{E_{\text{in}} - E_{\text{out}}}_{\substack{\text{Net energy transfer} \\ \text{by heat, work, and mass}}} = \underbrace{\Delta E_{\text{system}}}_{\substack{\text{Change in internal, kinetic,} \\ \text{potential, etc. energies}}}$$

$$-Q_{\text{out}} = \Delta U_{\text{ball}} = m(u_2 - u_1)$$

$$Q_{\text{out}} = mc(T_1 - T_2)$$

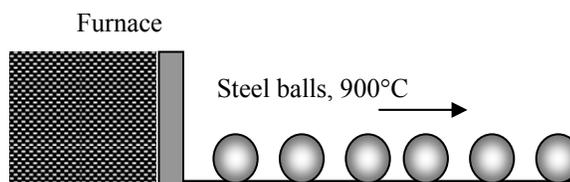

The total amount of heat transfer from a ball is

$$m = \rho V = \rho \frac{\pi D^3}{6} = (8085 \text{ kg/m}^3) \frac{\pi (0.012 \text{ m})^3}{6} = 0.007315 \text{ kg}$$

$$Q_{\text{out}} = mc(T_1 - T_2) = (0.007315 \text{ kg})(0.480 \text{ kJ/kg}\cdot^\circ\text{C})(900 - 850)^\circ\text{C} = 0.1756 \text{ kJ/ball}$$

Then the rate of heat transfer from the balls to the air becomes

$$\dot{Q}_{\text{total}} = \dot{n}_{\text{ball}} Q_{\text{out (per ball)}} = (1400 \text{ balls/min}) \times (0.1756 \text{ kJ/ball}) = \mathbf{245.8 \text{ kJ/min} = 4.10 \text{ kW}}$$

Therefore, heat is lost to the air at a rate of 4.10 kW.

(b) We again take a single bearing ball as the system. The entropy generated during this process can be determined by applying an entropy balance on an *extended system* that includes the ball and its immediate surroundings so that the boundary temperature of the extended system is at 30°C at all times:

$$\underbrace{S_{\text{in}} - S_{\text{out}}}_{\substack{\text{Net entropy transfer} \\ \text{by heat and mass}}} + \underbrace{S_{\text{gen}}}_{\substack{\text{Entropy} \\ \text{generation}}} = \underbrace{\Delta S_{\text{system}}}_{\substack{\text{Change} \\ \text{in entropy}}}$$

$$-\frac{Q_{\text{out}}}{T_b} + S_{\text{gen}} = \Delta S_{\text{system}} \rightarrow S_{\text{gen}} = \frac{Q_{\text{out}}}{T_b} + \Delta S_{\text{system}}$$

where

$$\Delta S_{\text{system}} = m(s_2 - s_1) = mc_{\text{avg}} \ln \frac{T_2}{T_1} = (0.007315 \text{ kg})(0.480 \text{ kJ/kg}\cdot\text{K}) \ln \frac{850 + 273}{900 + 273} = -0.0001530 \text{ kJ/K}$$

Substituting,

$$S_{\text{gen}} = \frac{Q_{\text{out}}}{T_b} + \Delta S_{\text{system}} = \frac{0.1756 \text{ kJ}}{303 \text{ K}} - 0.0001530 \text{ kJ/K} = 0.0004265 \text{ kJ/K (per ball)}$$

Then the rate of entropy generation becomes

$$\dot{S}_{\text{gen}} = S_{\text{gen}} \dot{n}_{\text{ball}} = (0.0004265 \text{ kJ/K}\cdot\text{ball})(1400 \text{ balls/min}) = 0.597 \text{ kJ/min}\cdot\text{K} = \mathbf{0.00995 \text{ kW/K}}$$

7-159 An egg is dropped into boiling water. The amount of heat transfer to the egg by the time it is cooked and the amount of entropy generation associated with this heat transfer process are to be determined.

Assumptions 1 The egg is spherical in shape with a radius of $r_0 = 2.75$ cm. **2** The thermal properties of the egg are constant. **3** Energy absorption or release associated with any chemical and/or phase changes within the egg is negligible. **4** There are no changes in kinetic and potential energies.

Properties The density and specific heat of the egg are given to be $\rho = 1020$ kg/m³ and $c_p = 3.32$ kJ/kg·°C.

Analysis We take the egg as the system. This is a closed system since no mass enters or leaves the egg. The energy balance for this closed system can be expressed as

$$\underbrace{E_{\text{in}} - E_{\text{out}}}_{\substack{\text{Net energy transfer} \\ \text{by heat, work, and mass}}} = \underbrace{\Delta E_{\text{system}}}_{\substack{\text{Change in internal, kinetic,} \\ \text{potential, etc. energies}}}$$

$$Q_{\text{in}} = \Delta U_{\text{egg}} = m(u_2 - u_1) = mc(T_2 - T_1)$$

Boiling
Water

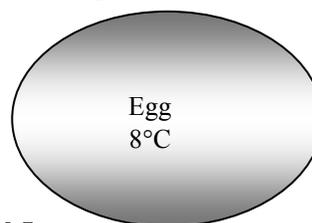

Then the mass of the egg and the amount of heat transfer become

$$m = \rho V = \rho \frac{\pi D^3}{6} = (1020 \text{ kg/m}^3) \frac{\pi (0.055 \text{ m})^3}{6} = 0.0889 \text{ kg}$$

$$Q_{\text{in}} = mc_p(T_2 - T_1) = (0.0889 \text{ kg})(3.32 \text{ kJ/kg}\cdot\text{°C})(70 - 8)\text{°C} = \mathbf{18.3 \text{ kJ}}$$

We again take a single egg as the system. The entropy generated during this process can be determined by applying an entropy balance on an *extended system* that includes the egg and its immediate surroundings so that the boundary temperature of the extended system is at 97°C at all times:

$$\underbrace{S_{\text{in}} - S_{\text{out}}}_{\substack{\text{Net entropy transfer} \\ \text{by heat and mass}}} + \underbrace{S_{\text{gen}}}_{\substack{\text{Entropy} \\ \text{generation}}} = \underbrace{\Delta S_{\text{system}}}_{\substack{\text{Change} \\ \text{in entropy}}}$$

$$\frac{Q_{\text{in}}}{T_b} + S_{\text{gen}} = \Delta S_{\text{system}} \rightarrow S_{\text{gen}} = -\frac{Q_{\text{in}}}{T_b} + \Delta S_{\text{system}}$$

where

$$\Delta S_{\text{system}} = m(s_2 - s_1) = mc_{\text{avg}} \ln \frac{T_2}{T_1} = (0.0889 \text{ kg})(3.32 \text{ kJ/kg}\cdot\text{K}) \ln \frac{70 + 273}{8 + 273} = 0.0588 \text{ kJ/K}$$

Substituting,

$$S_{\text{gen}} = -\frac{Q_{\text{in}}}{T_b} + \Delta S_{\text{system}} = -\frac{18.3 \text{ kJ}}{370 \text{ K}} + 0.0588 \text{ kJ/K} = \mathbf{0.00934 \text{ kJ/K}} \quad (\text{per egg})$$

7-160 Long cylindrical steel rods are heat-treated in an oven. The rate of heat transfer to the rods in the oven and the rate of entropy generation associated with this heat transfer process are to be determined.

Assumptions 1 The thermal properties of the rods are constant. **2** The changes in kinetic and potential energies are negligible.

Properties The density and specific heat of the steel rods are given to be $\rho = 7833 \text{ kg/m}^3$ and $c_p = 0.465 \text{ kJ/kg}\cdot^\circ\text{C}$.

Analysis (a) Noting that the rods enter the oven at a velocity of 3 m/min and exit at the same velocity, we can say that a 3-m long section of the rod is heated in the oven in 1 min. Then the mass of the rod heated in 1 minute is

$$m = \rho V = \rho LA = \rho L(\pi D^2 / 4) \\ = (7833 \text{ kg/m}^3)(3 \text{ m})[\pi(0.1 \text{ m})^2 / 4] = 184.6 \text{ kg}$$

We take the 3-m section of the rod in the oven as the system. The energy balance for this closed system can be expressed as

$$\underbrace{E_{\text{in}} - E_{\text{out}}}_{\substack{\text{Net energy transfer} \\ \text{by heat, work, and mass}}} = \underbrace{\Delta E_{\text{system}}}_{\substack{\text{Change in internal, kinetic,} \\ \text{potential, etc. energies}}} \\ Q_{\text{in}} = \Delta U_{\text{rod}} = m(u_2 - u_1) = mc(T_2 - T_1)$$

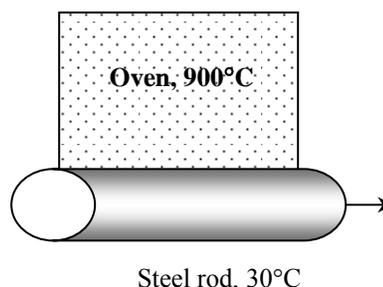

Substituting,

$$Q_{\text{in}} = mc(T_2 - T_1) = (184.6 \text{ kg})(0.465 \text{ kJ/kg}\cdot^\circ\text{C})(700 - 30)^\circ\text{C} = 57,512 \text{ kJ}$$

Noting that this much heat is transferred in 1 min, the rate of heat transfer to the rod becomes

$$\dot{Q}_{\text{in}} = Q_{\text{in}} / \Delta t = (57,512 \text{ kJ}) / (1 \text{ min}) = 57,512 \text{ kJ/min} = \mathbf{958.5 \text{ kW}}$$

(b) We again take the 3-m long section of the rod as the system. The entropy generated during this process can be determined by applying an entropy balance on an *extended system* that includes the rod and its immediate surroundings so that the boundary temperature of the extended system is at 900°C at all times:

$$\underbrace{S_{\text{in}} - S_{\text{out}}}_{\substack{\text{Net entropy transfer} \\ \text{by heat and mass}}} + \underbrace{S_{\text{gen}}}_{\substack{\text{Entropy} \\ \text{generation}}} = \underbrace{\Delta S_{\text{system}}}_{\substack{\text{Change} \\ \text{in entropy}}} \\ \frac{Q_{\text{in}}}{T_b} + S_{\text{gen}} = \Delta S_{\text{system}} \rightarrow S_{\text{gen}} = -\frac{Q_{\text{in}}}{T_b} + \Delta S_{\text{system}}$$

where

$$\Delta S_{\text{system}} = m(s_2 - s_1) = mc_{\text{avg}} \ln \frac{T_2}{T_1} = (184.6 \text{ kg})(0.465 \text{ kJ/kg}\cdot\text{K}) \ln \frac{700 + 273}{30 + 273} = 100.1 \text{ kJ/K}$$

Substituting,

$$S_{\text{gen}} = -\frac{Q_{\text{in}}}{T_b} + \Delta S_{\text{system}} = -\frac{57,512 \text{ kJ}}{900 + 273 \text{ K}} + 100.1 \text{ kJ/K} = 51.1 \text{ kJ/K}$$

Noting that this much entropy is generated in 1 min, the rate of entropy generation becomes

$$\dot{S}_{\text{gen}} = \frac{S_{\text{gen}}}{\Delta t} = \frac{51.1 \text{ kJ/K}}{1 \text{ min}} = 51.1 \text{ kJ/min}\cdot\text{K} = \mathbf{0.85 \text{ kW/K}}$$

7-161 The inner and outer surfaces of a brick wall are maintained at specified temperatures. The rate of entropy generation within the wall is to be determined.

Assumptions Steady operating conditions exist since the surface temperatures of the wall remain constant at the specified values.

Analysis We take the wall to be the system, which is a closed system. Under steady conditions, the rate form of the entropy balance for the wall simplifies to

$$\underbrace{\dot{S}_{\text{in}} - \dot{S}_{\text{out}}}_{\text{Rate of net entropy transfer by heat and mass}} + \underbrace{\dot{S}_{\text{gen}}}_{\text{Rate of entropy generation}} = \underbrace{\Delta \dot{S}_{\text{system}}}_{\text{Rate of change of entropy}} \overset{\neq 0}{=} 0$$

$$\frac{\dot{Q}_{\text{in}}}{T_{\text{b,in}}} - \frac{\dot{Q}_{\text{out}}}{T_{\text{b,out}}} + \dot{S}_{\text{gen,wall}} = 0$$

$$\frac{1890 \text{ W}}{293 \text{ K}} - \frac{1890 \text{ W}}{278 \text{ K}} + \dot{S}_{\text{gen,wall}} = 0$$

$$\dot{S}_{\text{gen,wall}} = \mathbf{0.348 \text{ W/K}}$$

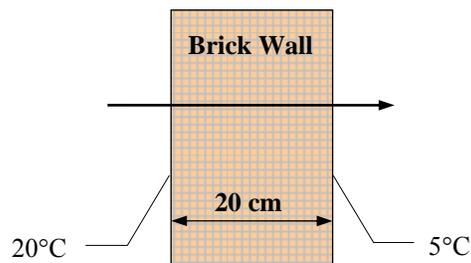

Therefore, the rate of entropy generation in the wall is 0.348 W/K.

7-162 A person is standing in a room at a specified temperature. The rate of entropy transfer from the body with heat is to be determined.

Assumptions Steady operating conditions exist.

Analysis Noting that Q/T represents entropy transfer with heat, the rate of entropy transfer from the body of the person accompanying heat transfer is

$$\dot{S}_{\text{transfer}} = \frac{\dot{Q}}{T} = \frac{336 \text{ W}}{307 \text{ K}} = \mathbf{1.094 \text{ W/K}}$$

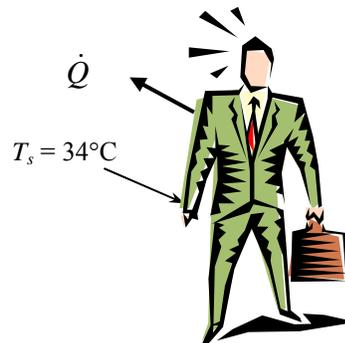

7-163 A 1000-W iron is left on the iron board with its base exposed to the air at 20°C. The rate of entropy generation is to be determined in steady operation.

Assumptions Steady operating conditions exist.

Analysis We take the iron to be the system, which is a closed system. Considering that the iron experiences no change in its properties in steady operation, including its entropy, the rate form of the entropy balance for the iron simplifies to

$$\underbrace{\dot{S}_{\text{in}} - \dot{S}_{\text{out}}}_{\text{Rate of net entropy transfer by heat and mass}} + \underbrace{\dot{S}_{\text{gen}}}_{\text{Rate of entropy generation}} = \underbrace{\Delta \dot{S}_{\text{system}}}_{\text{Rate of change of entropy}} \stackrel{\neq 0}{=} 0$$

$$-\frac{\dot{Q}_{\text{out}}}{T_{\text{b,out}}} + \dot{S}_{\text{gen,iron}} = 0$$

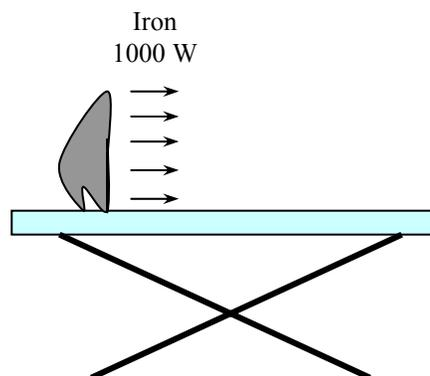

Therefore,

$$\dot{S}_{\text{gen,iron}} = \frac{\dot{Q}_{\text{out}}}{T_{\text{b,out}}} = \frac{1000 \text{ W}}{673 \text{ K}} = \mathbf{1.486 \text{ W/K}}$$

The rate of total entropy generation during this process is determined by applying the entropy balance on an *extended system* that includes the iron and its immediate surroundings so that the boundary temperature of the extended system is at 20°C at all times. It gives

$$\dot{S}_{\text{gen,total}} = \frac{\dot{Q}_{\text{out}}}{T_{\text{b,out}}} = \frac{\dot{Q}}{T_{\text{surr}}} = \frac{1000 \text{ W}}{293 \text{ K}} = \mathbf{3.413 \text{ W/K}}$$

Discussion Note that only about one-third of the entropy generation occurs within the iron. The rest occurs in the air surrounding the iron as the temperature drops from 400°C to 20°C without serving any useful purpose.

7-164E A cylinder contains saturated liquid water at a specified pressure. Heat is transferred to liquid from a source and some liquid evaporates. The total entropy generation during this process is to be determined.

Assumptions 1 No heat loss occurs from the water to the surroundings during the process. **2** The pressure inside the cylinder and thus the water temperature remains constant during the process. **3** No irreversibilities occur within the cylinder during the process.

Analysis The pressure of the steam is maintained constant. Therefore, the temperature of the steam remains constant also at

$$T = T_{\text{sat}@25 \text{ psia}} = 240.03^\circ\text{F} = 700 \text{ R} \quad (\text{Table A-5E})$$

Taking the contents of the cylinder as the system and noting that the temperature of water remains constant, the entropy change of the system during this isothermal, internally reversible process becomes

$$\Delta S_{\text{system}} = \frac{Q_{\text{sys,in}}}{T_{\text{sys}}} = \frac{400 \text{ Btu}}{700 \text{ R}} = 0.572 \text{ Btu/R}$$

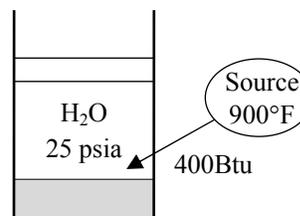

Similarly, the entropy change of the heat source is determined from

$$\Delta S_{\text{source}} = -\frac{Q_{\text{source,out}}}{T_{\text{source}}} = -\frac{400 \text{ Btu}}{900 + 460 \text{ R}} = -0.294 \text{ Btu/R}$$

Now consider a combined system that includes the cylinder and the source. Noting that no heat or mass crosses the boundaries of this combined system, the entropy balance for it can be expressed as

$$\underbrace{S_{\text{in}} - S_{\text{out}}}_{\substack{\text{Net entropy transfer} \\ \text{by heat and mass}}} + \underbrace{S_{\text{gen}}}_{\substack{\text{Entropy} \\ \text{generation}}} = \underbrace{\Delta S_{\text{system}}}_{\substack{\text{Change} \\ \text{in entropy}}}$$

$$0 + S_{\text{gen,total}} = \Delta S_{\text{water}} + \Delta S_{\text{source}}$$

Therefore, the total entropy generated during this process is

$$S_{\text{gen,total}} = \Delta S_{\text{water}} + \Delta S_{\text{source}} = 0.572 - 0.294 = \mathbf{0.278 \text{ Btu/R}}$$

Discussion The entropy generation in this case is entirely due to the irreversible heat transfer through a finite temperature difference. We could also determine the total entropy generation by writing an energy balance on an extended system that includes the system and its immediate surroundings so that part of the boundary of the extended system, where heat transfer occurs, is at the source temperature.

7-165E Steam is decelerated in a diffuser from a velocity of 900 ft/s to 100 ft/s. The mass flow rate of steam and the rate of entropy generation are to be determined.

Assumptions 1 This is a steady-flow process since there is no change with time. **2** Potential energy changes are negligible. **3** There are no work interactions.

Properties The properties of steam at the inlet and the exit of the diffuser are (Tables A-4E through A-6E)

$$\left. \begin{array}{l} P_1 = 20 \text{ psia} \\ T_1 = 240^\circ\text{F} \end{array} \right\} \begin{array}{l} h_1 = 1162.3 \text{ Btu/lbm} \\ s_1 = 1.7406 \text{ Btu/lbm} \cdot \text{R} \end{array}$$

$$\left. \begin{array}{l} T_2 = 240^\circ\text{F} \\ \text{sat. vapor} \end{array} \right\} \begin{array}{l} h_2 = 1160.5 \text{ Btu/lbm} \\ s_2 = 1.7141 \text{ Btu/lbm} \cdot \text{R} \\ v_2 = 16.316 \text{ ft}^3/\text{lbm} \end{array}$$

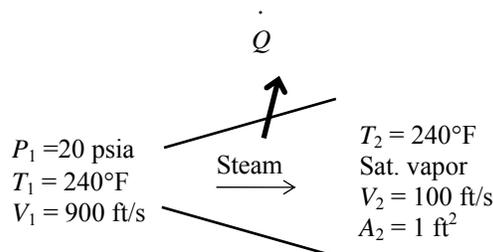

Analysis (a) The mass flow rate of the steam can be determined from its definition to be

$$\dot{m} = \frac{1}{v_2} A_2 V_2 = \frac{1}{16.316 \text{ ft}^3/\text{lbm}} (1 \text{ ft}^2)(100 \text{ ft/s}) = \mathbf{6.129 \text{ lbm/s}}$$

(b) We take diffuser as the system, which is a control volume since mass crosses the boundary. The energy balance for this steady-flow system can be expressed in the rate form as

$$\underbrace{\dot{E}_{\text{in}} - \dot{E}_{\text{out}}}_{\text{Rate of net energy transfer by heat, work, and mass}} = \underbrace{\Delta \dot{E}_{\text{system}}}_{\text{Rate of change in internal, kinetic, potential, etc. energies}} \stackrel{\approx 0 \text{ (steady)}}{=} 0$$

$$\dot{E}_{\text{in}} = \dot{E}_{\text{out}}$$

$$\dot{m}(h_1 + V_1^2/2) - \dot{Q}_{\text{out}} = \dot{m}(h_2 + V_2^2/2) \quad (\text{since } \dot{W} \cong \Delta p e \cong 0)$$

$$\dot{Q}_{\text{out}} = -\dot{m} \left(h_2 - h_1 + \frac{V_2^2 - V_1^2}{2} \right)$$

Substituting, the rate of heat loss from the diffuser is determined to be

$$\dot{Q}_{\text{out}} = -(6.129 \text{ lbm/s}) \left(1160.5 - 1162.3 + \frac{(100 \text{ ft/s})^2 - (900 \text{ ft/s})^2}{2} \left(\frac{1 \text{ Btu/lbm}}{25,037 \text{ ft}^2/\text{s}^2} \right) \right) = 108.42 \text{ Btu/s}$$

The rate of total entropy generation during this process is determined by applying the entropy balance on an *extended system* that includes the diffuser and its immediate surroundings so that the boundary temperature of the extended system is 77°F at all times. It gives

$$\underbrace{\dot{S}_{\text{in}} - \dot{S}_{\text{out}}}_{\text{Rate of net entropy transfer by heat and mass}} + \underbrace{\dot{S}_{\text{gen}}}_{\text{Rate of entropy generation}} = \underbrace{\Delta \dot{S}_{\text{system}}}_{\text{Rate of change of entropy}} \stackrel{\approx 0}{=} 0$$

$$\dot{m}s_1 - \dot{m}s_2 - \frac{\dot{Q}_{\text{out}}}{T_{\text{b,surr}}} + \dot{S}_{\text{gen}} = 0$$

Substituting, the total rate of entropy generation during this process becomes

$$\dot{S}_{\text{gen}} = \dot{m}(s_2 - s_1) + \frac{\dot{Q}_{\text{out}}}{T_{\text{b,surr}}} = (6.129 \text{ lbm/s})(1.7141 - 1.7406) \text{ Btu/lbm} \cdot \text{R} + \frac{108.42 \text{ Btu/s}}{537 \text{ R}} = \mathbf{0.0395 \text{ Btu/s} \cdot \text{R}}$$

7-166 Steam expands in a turbine from a specified state to another specified state. The rate of entropy generation during this process is to be determined.

Assumptions 1 This is a steady-flow process since there is no change with time. **2** Kinetic and potential energy changes are negligible.

Properties From the steam tables (Tables A-4 through 6)

$$\left. \begin{array}{l} P_1 = 6 \text{ MPa} \\ T_1 = 450^\circ\text{C} \end{array} \right\} \begin{array}{l} h_1 = 3302.9 \text{ kJ/kg} \\ s_1 = 6.7219 \text{ kJ/kg} \cdot \text{K} \end{array}$$

$$\left. \begin{array}{l} P_2 = 20 \text{ kPa} \\ \text{sat. vapor} \end{array} \right\} \begin{array}{l} h_2 = 2608.9 \text{ kJ/kg} \\ s_2 = 7.9073 \text{ kJ/kg} \cdot \text{K} \end{array}$$

Analysis There is only one inlet and one exit, and thus $\dot{m}_1 = \dot{m}_2 = \dot{m}$.

We take the turbine as the system, which is a control volume since mass crosses the boundary. The energy balance for this steady-flow system can be expressed in the rate form as

$$\underbrace{\dot{E}_{\text{in}} - \dot{E}_{\text{out}}}_{\text{Rate of net energy transfer by heat, work, and mass}} = \underbrace{\Delta \dot{E}_{\text{system}}^{\text{?0}}}_{\text{Rate of change in internal, kinetic, potential, etc. energies}} \stackrel{\text{(steady)}}{=} 0$$

$$\dot{E}_{\text{in}} = \dot{E}_{\text{out}}$$

$$\dot{m}h_1 = \dot{Q}_{\text{out}} + \dot{W}_{\text{out}} + \dot{m}h_2$$

$$\dot{Q}_{\text{out}} = \dot{m}(h_1 - h_2) - \dot{W}_{\text{out}}$$

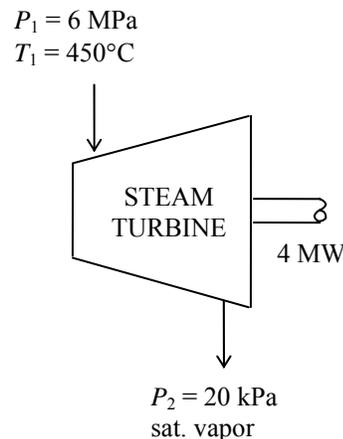

Substituting,

$$\dot{Q}_{\text{out}} = (25,000/3600 \text{ kg/s})(3302.9 - 2608.9) \text{ kJ/kg} - 4000 \text{ kJ/s} = 819.3 \text{ kJ/s}$$

The rate of total entropy generation during this process is determined by applying the entropy balance on an *extended system* that includes the turbine and its immediate surroundings so that the boundary temperature of the extended system is 25°C at all times. It gives

$$\underbrace{\dot{S}_{\text{in}} - \dot{S}_{\text{out}}}_{\text{Rate of net entropy transfer by heat and mass}} + \underbrace{\dot{S}_{\text{gen}}}_{\text{Rate of entropy generation}} = \underbrace{\Delta \dot{S}_{\text{system}}^{\text{?0}}}_{\text{Rate of change of entropy}} = 0$$

$$\dot{m}s_1 - \dot{m}s_2 - \frac{\dot{Q}_{\text{out}}}{T_{\text{b,surr}}} + \dot{S}_{\text{gen}} = 0$$

Substituting, the rate of entropy generation during this process is determined to be

$$\dot{S}_{\text{gen}} = \dot{m}(s_2 - s_1) + \frac{\dot{Q}_{\text{out}}}{T_{\text{b,surr}}} = (25,000/3600 \text{ kg/s})(7.9073 - 6.7219) \text{ kJ/kg} \cdot \text{K} + \frac{819.3 \text{ kW}}{298 \text{ K}} = \mathbf{11.0 \text{ kW/K}}$$

7-167 A hot water stream is mixed with a cold water stream. For a specified mixture temperature, the mass flow rate of cold water stream and the rate of entropy generation are to be determined.

Assumptions 1 Steady operating conditions exist. **2** The mixing chamber is well-insulated so that heat loss to the surroundings is negligible. **3** Changes in the kinetic and potential energies of fluid streams are negligible.

Properties Noting that $T < T_{\text{sat}@200 \text{ kPa}} = 120.21^\circ\text{C}$, the water in all three streams exists as a compressed liquid, which can be approximated as a saturated liquid at the given temperature. Thus from Table A-4,

$$\left. \begin{array}{l} P_1 = 200 \text{ kPa} \\ T_1 = 70^\circ\text{C} \end{array} \right\} \begin{array}{l} h_1 \cong h_{f@70^\circ\text{C}} = 293.07 \text{ kJ/kg} \\ s_1 \cong s_{f@70^\circ\text{C}} = 0.9551 \text{ kJ/kg} \cdot \text{K} \end{array}$$

$$\left. \begin{array}{l} P_2 = 200 \text{ kPa} \\ T_2 = 20^\circ\text{C} \end{array} \right\} \begin{array}{l} h_2 \cong h_{f@20^\circ\text{C}} = 83.91 \text{ kJ/kg} \\ s_2 \cong s_{f@20^\circ\text{C}} = 0.2965 \text{ kJ/kg} \cdot \text{K} \end{array}$$

$$\left. \begin{array}{l} P_3 = 200 \text{ kPa} \\ T_3 = 42^\circ\text{C} \end{array} \right\} \begin{array}{l} h_3 \cong h_{f@42^\circ\text{C}} = 175.90 \text{ kJ/kg} \\ s_3 \cong s_{f@42^\circ\text{C}} = 0.5990 \text{ kJ/kg} \cdot \text{K} \end{array}$$

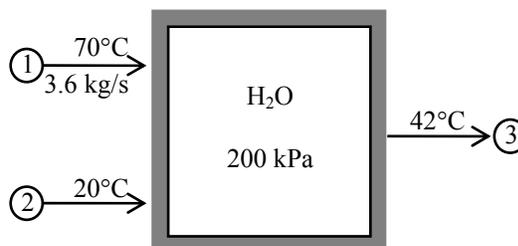

Analysis (a) We take the mixing chamber as the system, which is a control volume. The mass and energy balances for this steady-flow system can be expressed in the rate form as

$$\text{Mass balance: } \dot{m}_{\text{in}} - \dot{m}_{\text{out}} = \Delta \dot{E}_{\text{system}}^{\neq 0 \text{ (steady)}} = 0 \longrightarrow \dot{m}_1 + \dot{m}_2 = \dot{m}_3$$

Energy balance:

$$\underbrace{\dot{E}_{\text{in}} - \dot{E}_{\text{out}}}_{\text{Rate of net energy transfer by heat, work, and mass}} = \underbrace{\Delta \dot{E}_{\text{system}}^{\neq 0 \text{ (steady)}}}_{\text{Rate of change in internal, kinetic, potential, etc. energies}} = 0$$

$$\dot{E}_{\text{in}} = \dot{E}_{\text{out}}$$

$$\dot{m}_1 h_1 + \dot{m}_2 h_2 = \dot{m}_3 h_3 \quad (\text{since } \dot{Q} = \dot{W} = \Delta \text{ke} \cong \Delta \text{pe} \cong 0)$$

$$\text{Combining the two relations gives } \dot{m}_1 h_1 + \dot{m}_2 h_2 = (\dot{m}_1 + \dot{m}_2) h_3$$

Solving for \dot{m}_2 and substituting, the mass flow rate of cold water stream is determined to be

$$\dot{m}_2 = \frac{h_1 - h_3}{h_3 - h_2} \dot{m}_1 = \frac{(293.07 - 175.90) \text{ kJ/kg}}{(175.90 - 83.91) \text{ kJ/kg}} (3.6 \text{ kg/s}) = \mathbf{4.586 \text{ kg/s}}$$

$$\text{Also, } \dot{m}_3 = \dot{m}_1 + \dot{m}_2 = 3.6 + 4.586 = 8.186 \text{ kg/s}$$

(b) Noting that the mixing chamber is adiabatic and thus there is no heat transfer to the surroundings, the entropy balance of the steady-flow system (the mixing chamber) can be expressed as

$$\underbrace{\dot{S}_{\text{in}} - \dot{S}_{\text{out}}}_{\text{Rate of net entropy transfer by heat and mass}} + \underbrace{\dot{S}_{\text{gen}}}_{\text{Rate of entropy generation}} = \underbrace{\Delta \dot{S}_{\text{system}}^{\neq 0}}_{\text{Rate of change of entropy}} = 0$$

$$\dot{m}_1 s_1 + \dot{m}_2 s_2 - \dot{m}_3 s_3 + \dot{S}_{\text{gen}} = 0$$

Substituting, the total rate of entropy generation during this process becomes

$$\begin{aligned} \dot{S}_{\text{gen}} &= \dot{m}_3 s_3 - \dot{m}_2 s_2 - \dot{m}_1 s_1 \\ &= (8.186 \text{ kg/s})(0.5990 \text{ kJ/kg} \cdot \text{K}) - (4.586 \text{ kg/s})(0.2965 \text{ kJ/kg} \cdot \text{K}) - (3.6 \text{ kg/s})(0.9551 \text{ kJ/kg} \cdot \text{K}) \\ &= \mathbf{0.1054 \text{ kW/K}} \end{aligned}$$

7-168 Liquid water is heated in a chamber by mixing it with superheated steam. For a specified mixing temperature, the mass flow rate of the steam and the rate of entropy generation are to be determined.

Assumptions 1 This is a steady-flow process since there is no change with time. **2** Kinetic and potential energy changes are negligible. **3** There are no work interactions.

Properties Noting that $T < T_{\text{sat}} @ 200 \text{ kPa} = 120.21^\circ\text{C}$, the cold water and the exit mixture streams exist as a compressed liquid, which can be approximated as a saturated liquid at the given temperature. From Tables A-4 through A-6,

$$\left. \begin{array}{l} P_1 = 200 \text{ kPa} \\ T_1 = 20^\circ\text{C} \end{array} \right\} \begin{array}{l} h_1 \cong h_{f@20^\circ\text{C}} = 83.91 \text{ kJ/kg} \\ s_1 \cong s_{f@20^\circ\text{C}} = 0.2965 \text{ kJ/kg} \cdot \text{K} \end{array}$$

$$\left. \begin{array}{l} P_2 = 200 \text{ kPa} \\ T_2 = 150^\circ\text{C} \end{array} \right\} \begin{array}{l} h_2 = 2769.1 \text{ kJ/kg} \\ s_2 = 7.2810 \text{ kJ/kg} \cdot \text{K} \end{array}$$

$$\left. \begin{array}{l} P_3 = 200 \text{ kPa} \\ T_3 = 60^\circ\text{C} \end{array} \right\} \begin{array}{l} h_3 \cong h_{f@60^\circ\text{C}} = 251.18 \text{ kJ/kg} \\ s_3 \cong s_{f@60^\circ\text{C}} = 0.8313 \text{ kJ/kg} \cdot \text{K} \end{array}$$

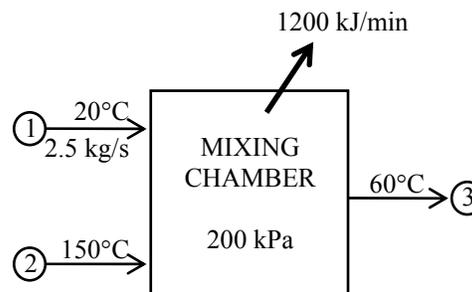

Analysis (a) We take the mixing chamber as the system, which is a control volume. The mass and energy balances for this steady-flow system can be expressed in the rate form as

$$\text{Mass balance: } \dot{m}_{\text{in}} - \dot{m}_{\text{out}} = \Delta \dot{E}_{\text{system}}^{\text{no}} \text{ (steady)} = 0 \longrightarrow \dot{m}_1 + \dot{m}_2 = \dot{m}_3$$

Energy balance:

$$\underbrace{\dot{E}_{\text{in}} - \dot{E}_{\text{out}}}_{\text{Rate of net energy transfer by heat, work, and mass}} = \underbrace{\Delta \dot{E}_{\text{system}}^{\text{no}} \text{ (steady)}}_{\text{Rate of change in internal, kinetic, potential, etc. energies}} = 0$$

$$\dot{E}_{\text{in}} = \dot{E}_{\text{out}}$$

$$\dot{m}_1 h_1 + \dot{m}_2 h_2 = \dot{Q}_{\text{out}} + \dot{m}_3 h_3$$

Combining the two relations gives $\dot{Q}_{\text{out}} = \dot{m}_1 h_1 + \dot{m}_2 h_2 - (\dot{m}_1 + \dot{m}_2) h_3 = \dot{m}_1 (h_1 - h_3) + \dot{m}_2 (h_2 - h_3)$

Solving for \dot{m}_2 and substituting, the mass flow rate of the superheated steam is determined to be

$$\dot{m}_2 = \frac{\dot{Q}_{\text{out}} - \dot{m}_1 (h_1 - h_3)}{h_2 - h_3} = \frac{(1200/60 \text{ kJ/s}) - (2.5 \text{ kg/s})(83.91 - 251.18) \text{ kJ/kg}}{(2769.1 - 251.18) \text{ kJ/kg}} = \mathbf{0.166 \text{ kg/s}}$$

$$\text{Also, } \dot{m}_3 = \dot{m}_1 + \dot{m}_2 = 2.5 + 0.166 = 2.666 \text{ kg/s}$$

(b) The rate of total entropy generation during this process is determined by applying the entropy balance on an *extended system* that includes the mixing chamber and its immediate surroundings so that the boundary temperature of the extended system is 25°C at all times. It gives

$$\underbrace{\dot{S}_{\text{in}} - \dot{S}_{\text{out}}}_{\text{Rate of net entropy transfer by heat and mass}} + \underbrace{\dot{S}_{\text{gen}}}_{\text{Rate of entropy generation}} = \underbrace{\Delta \dot{S}_{\text{system}}^{\text{no}}}_{\text{Rate of change of entropy}} = 0$$

$$\dot{m}_1 s_1 + \dot{m}_2 s_2 - \dot{m}_3 s_3 - \frac{\dot{Q}_{\text{out}}}{T_{\text{b,surr}}} + \dot{S}_{\text{gen}} = 0$$

Substituting, the rate of entropy generation during this process is determined to be

$$\begin{aligned} \dot{S}_{\text{gen}} &= \dot{m}_3 s_3 - \dot{m}_2 s_2 - \dot{m}_1 s_1 + \frac{\dot{Q}_{\text{out}}}{T_{\text{b,surr}}} \\ &= (2.666 \text{ kg/s})(0.8313 \text{ kJ/kg} \cdot \text{K}) - (0.166 \text{ kg/s})(7.2810 \text{ kJ/kg} \cdot \text{K}) \\ &\quad - (2.5 \text{ kg/s})(0.2965 \text{ kJ/kg} \cdot \text{K}) + \frac{(1200/60 \text{ kJ/s})}{298 \text{ K}} \\ &= \mathbf{0.333 \text{ kW/K}} \end{aligned}$$

7-169 A rigid tank initially contains saturated liquid water. A valve at the bottom of the tank is opened, and half of mass in liquid form is withdrawn from the tank. The temperature in the tank is maintained constant. The amount of heat transfer and the entropy generation during this process are to be determined.

Assumptions 1 This is an unsteady process since the conditions within the device are changing during the process, but it can be analyzed as a uniform-flow process since the state of fluid leaving the device remains constant. **2** Kinetic and potential energies are negligible. **3** There are no work interactions involved. **4** The direction of heat transfer is to the tank (will be verified).

Properties The properties of water are (Tables A-4 through A-6)

$$T_1 = 150^\circ\text{C} \left\{ \begin{array}{l} \nu_1 = \nu_{f@150^\circ\text{C}} = 0.001091 \text{ m}^3/\text{kg} \\ u_1 = u_{f@150^\circ\text{C}} = 631.66 \text{ kJ/kg} \\ s_1 = s_{f@150^\circ\text{C}} = 1.8418 \text{ kJ/kg} \cdot \text{K} \end{array} \right.$$

$$T_e = 150^\circ\text{C} \left\{ \begin{array}{l} h_e = h_{f@150^\circ\text{C}} = 632.18 \text{ kJ/kg} \\ s_e = s_{f@150^\circ\text{C}} = 1.8418 \text{ kJ/kg} \cdot \text{K} \end{array} \right.$$

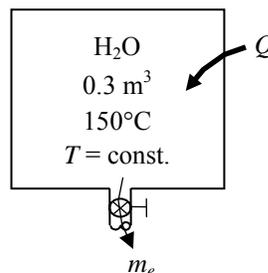

Analysis (a) We take the tank as the system, which is a control volume since mass crosses the boundary. Noting that the microscopic energies of flowing and nonflowing fluids are represented by enthalpy h and internal energy u , respectively, the mass and energy balances for this uniform-flow system can be expressed as

Mass balance:

$$m_{\text{in}} - m_{\text{out}} = \Delta m_{\text{system}} \rightarrow m_e = m_1 - m_2$$

Energy balance:

$$\underbrace{E_{\text{in}} - E_{\text{out}}}_{\text{Net energy transfer by heat, work, and mass}} = \underbrace{\Delta E_{\text{system}}}_{\text{Change in internal, kinetic, potential, etc. energies}}$$

$$Q_{\text{in}} = m_e h_e + m_2 u_2 - m_1 u_1 \quad (\text{since } W \cong \text{ke} \cong \text{pe} \cong 0)$$

The initial and the final masses in the tank are

$$m_1 = \frac{\nu}{\nu_1} = \frac{0.3 \text{ m}^3}{0.001091 \text{ m}^3/\text{kg}} = 275.10 \text{ kg}$$

$$m_2 = \frac{1}{2} m_1 = \frac{1}{2} (275.10 \text{ kg}) = 137.55 \text{ kg} = m_e$$

Now we determine the final internal energy and entropy,

$$\nu_2 = \frac{\nu}{m_2} = \frac{0.3 \text{ m}^3}{137.55 \text{ kg}} = 0.002181 \text{ m}^3/\text{kg}$$

$$x_2 = \frac{\nu_2 - \nu_f}{\nu_{fg}} = \frac{0.002181 - 0.001091}{0.39248 - 0.001091} = 0.002786$$

$$T_2 = 150^\circ\text{C} \left\{ \begin{array}{l} u_2 = u_f + x_2 u_{fg} = 631.66 + (0.002786)(1927.4) = 637.03 \text{ kJ/kg} \\ s_2 = s_f + x_2 s_{fg} = 1.8418 + (0.002786)(4.9953) = 1.8557 \text{ kJ/kg} \cdot \text{K} \end{array} \right.$$

The heat transfer during this process is determined by substituting these values into the energy balance equation,

$$\begin{aligned}
 Q_{\text{in}} &= m_e h_e + m_2 u_2 - m_1 u_1 \\
 &= (137.55 \text{ kg})(632.18 \text{ kJ/kg}) + (137.55 \text{ kg})(637.03 \text{ kJ/kg}) - (275.10 \text{ kg})(631.66 \text{ kJ/kg}) \\
 &= \mathbf{810 \text{ kJ}}
 \end{aligned}$$

(b) The total entropy generation is determined by considering a combined system that includes the tank and the heat source. Noting that no heat crosses the boundaries of this combined system and no mass enters, the entropy balance for it can be expressed as

$$\underbrace{S_{\text{in}} - S_{\text{out}}}_{\substack{\text{Net entropy transfer} \\ \text{by heat and mass}}} + \underbrace{S_{\text{gen}}}_{\substack{\text{Entropy} \\ \text{generation}}} = \underbrace{\Delta S_{\text{system}}}_{\substack{\text{Change} \\ \text{in entropy}}} \longrightarrow -m_e s_e + S_{\text{gen}} = \Delta S_{\text{tank}} + \Delta S_{\text{source}}$$

Therefore, the total entropy generated during this process is

$$\begin{aligned}
 S_{\text{gen}} &= m_e s_e + \Delta S_{\text{tank}} + \Delta S_{\text{source}} = m_e s_e + (m_2 s_2 - m_1 s_1) - \frac{Q_{\text{source, out}}}{T_{\text{source}}} \\
 &= (137.55 \text{ kg})(1.8418 \text{ kJ/kg} \cdot \text{K}) + (137.55 \text{ kg})(1.8557 \text{ kJ/kg} \cdot \text{K}) \\
 &\quad - (275.10 \text{ kg})(1.8418 \text{ kJ/kg} \cdot \text{K}) - \frac{810 \text{ kJ}}{423 \text{ K}} \\
 &= \mathbf{0.202 \text{ kJ/K}}
 \end{aligned}$$

7-170E An unknown mass of iron is dropped into water in an insulated tank while being stirred by a 200-W paddle wheel. Thermal equilibrium is established after 10 min. The mass of the iron block and the entropy generated during this process are to be determined.

Assumptions 1 Both the water and the iron block are incompressible substances with constant specific heats at room temperature. **2** The system is stationary and thus the kinetic and potential energy changes are zero. **3** The system is well-insulated and thus there is no heat transfer.

Properties The specific heats of water and the iron block at room temperature are $c_{p, \text{water}} = 1.00 \text{ Btu/lbm}\cdot^\circ\text{F}$ and $c_{p, \text{iron}} = 0.107 \text{ Btu/lbm}\cdot^\circ\text{F}$ (Table A-3E). The density of water at room temperature is 62.1 lbm/ft^3 .

Analysis (a) We take the entire contents of the tank, water + iron block, as the system. This is a closed system since no mass crosses the system boundary during the process. The energy balance on the system can be expressed as

$$\underbrace{E_{\text{in}} - E_{\text{out}}}_{\substack{\text{Net energy transfer} \\ \text{by heat, work, and mass}}} = \underbrace{\Delta E_{\text{system}}}_{\substack{\text{Change in internal, kinetic,} \\ \text{potential, etc. energies}}}$$

$$W_{\text{pw, in}} = \Delta U$$

or,

$$W_{\text{pw, in}} = \Delta U_{\text{iron}} + \Delta U_{\text{water}}$$

$$W_{\text{pw, in}} = [mc(T_2 - T_1)]_{\text{iron}} + [mc(T_2 - T_1)]_{\text{water}}$$

where

$$m_{\text{water}} = \rho V = (62.1 \text{ lbm/ft}^3)(0.8 \text{ ft}^3) = 49.7 \text{ lbm}$$

$$W_{\text{pw}} = \dot{W}_{\text{pw}} \Delta t = (0.2 \text{ kJ/s})(10 \times 60 \text{ s}) \left(\frac{1 \text{ Btu}}{1.055 \text{ kJ}} \right) = 113.7 \text{ Btu}$$

Using specific heat values for iron and liquid water and substituting,

$$113.7 \text{ Btu} = m_{\text{iron}}(0.107 \text{ Btu/lbm}\cdot^\circ\text{F})(75 - 185)^\circ\text{F} + (49.7 \text{ lbm})(1.00 \text{ Btu/lbm}\cdot^\circ\text{F})(75 - 70)^\circ\text{F}$$

$$m_{\text{iron}} = \mathbf{11.4 \text{ lbm}}$$

(b) Again we take the iron + water in the tank to be the system. Noting that no heat or mass crosses the boundaries of this combined system, the entropy balance for it can be expressed as

$$\underbrace{S_{\text{in}} - S_{\text{out}}}_{\substack{\text{Net entropy transfer} \\ \text{by heat and mass}}} + \underbrace{S_{\text{gen}}}_{\substack{\text{Entropy} \\ \text{generation}}} = \underbrace{\Delta S_{\text{system}}}_{\substack{\text{Change} \\ \text{in entropy}}}$$

$$0 + S_{\text{gen, total}} = \Delta S_{\text{iron}} + \Delta S_{\text{water}}$$

where

$$\Delta S_{\text{iron}} = mc_{\text{avg}} \ln \left(\frac{T_2}{T_1} \right) = (11.4 \text{ lbm})(0.107 \text{ Btu/lbm}\cdot\text{R}) \ln \left(\frac{535 \text{ R}}{645 \text{ R}} \right) = -0.228 \text{ Btu/R}$$

$$\Delta S_{\text{water}} = mc_{\text{avg}} \ln \left(\frac{T_2}{T_1} \right) = (49.6 \text{ lbm})(1.0 \text{ Btu/lbm}\cdot\text{R}) \ln \left(\frac{535 \text{ R}}{530 \text{ R}} \right) = 0.466 \text{ Btu/R}$$

Therefore, the total entropy generated during this process is

$$\Delta S_{\text{total}} = S_{\text{gen, total}} = \Delta S_{\text{iron}} + \Delta S_{\text{water}} = -0.228 + 0.466 = \mathbf{0.238 \text{ Btu/R}}$$

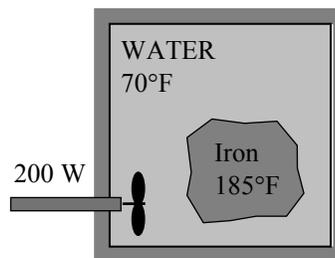

7-171E Air is compressed steadily by a compressor. The mass flow rate of air through the compressor and the rate of entropy generation are to be determined.

Assumptions **1** This is a steady-flow process since there is no change with time. **2** Potential energy changes are negligible. **3** Air is an ideal gas with variable specific heats.

Properties The gas constant of air is 0.06855 Btu/lbm·R. The inlet and exit enthalpies of air are (Table A-17)

$$\left. \begin{array}{l} T_1 = 520 \text{ R} \\ P_1 = 15 \text{ psia} \end{array} \right\} \begin{array}{l} h_1 = 124.27 \text{ Btu/lbm} \\ s_1^\circ = 0.59173 \text{ Btu/lbm} \cdot \text{R} \end{array}$$

$$\left. \begin{array}{l} T_2 = 1080 \text{ R} \\ P_2 = 150 \text{ psia} \end{array} \right\} \begin{array}{l} h_2 = 260.97 \text{ Btu/lbm} \\ s_2^\circ = 0.76964 \text{ Btu/lbm} \cdot \text{R} \end{array}$$

Analysis (a) We take the compressor as the system, which is a control volume since mass crosses the boundary. The energy balance for this steady-flow system can be expressed in the rate form as

$$\underbrace{\dot{E}_{\text{in}} - \dot{E}_{\text{out}}}_{\substack{\text{Rate of net energy transfer} \\ \text{by heat, work, and mass}}} = \underbrace{\Delta \dot{E}_{\text{system}}}_{\substack{\text{Rate of change in internal, kinetic,} \\ \text{potential, etc. energies}}} \stackrel{\neq 0}{=} 0$$

$$\dot{E}_{\text{in}} = \dot{E}_{\text{out}}$$

$$\dot{W}_{\text{in}} + \dot{m}(h_1 + V_1^2/2) = \dot{Q}_{\text{out}} + \dot{m}(h_2 + V_2^2/2) \quad (\text{since } \Delta p_e \cong 0)$$

$$\dot{W}_{\text{in}} - \dot{Q}_{\text{out}} = \dot{m} \left(h_2 - h_1 + \frac{V_2^2 - V_1^2}{2} \right)$$

Substituting, the mass flow rate is determined to be

$$\text{Thus, } (400 \text{ hp}) \left(\frac{0.7068 \text{ Btu/s}}{1 \text{ hp}} \right) - \frac{1500 \text{ Btu}}{60 \text{ s}} = \dot{m} \left(260.97 - 124.27 + \frac{(350 \text{ ft/s})^2}{2} \left(\frac{1 \text{ Btu/lbm}}{25,037 \text{ ft}^2/\text{s}^2} \right) \right)$$

It yields $\dot{m} = \mathbf{1.852 \text{ lbm/s}}$

(b) Again we take the compressor to be the system. Noting that no heat or mass crosses the boundaries of this combined system, the entropy balance for it can be expressed as

$$\underbrace{\dot{S}_{\text{in}} - \dot{S}_{\text{out}}}_{\substack{\text{Rate of net entropy transfer} \\ \text{by heat and mass}}} + \underbrace{\dot{S}_{\text{gen}}}_{\substack{\text{Rate of entropy} \\ \text{generation}}} = \underbrace{\Delta \dot{S}_{\text{system}}}_{\substack{\text{Rate of change} \\ \text{of entropy}}} \stackrel{\neq 0}{=} 0$$

$$\dot{m}s_1 - \dot{m}s_2 - \frac{\dot{Q}_{\text{out}}}{T_{\text{b,surr}}} + \dot{S}_{\text{gen}} = 0 \rightarrow \dot{S}_{\text{gen}} = \dot{m}(s_2 - s_1) + \frac{\dot{Q}_{\text{out}}}{T_{\text{b,surr}}}$$

where

$$\Delta \dot{S}_{\text{air}} = \dot{m}(s_2 - s_1) = \dot{m} \left(s_2^\circ - s_1^\circ - R \ln \frac{P_2}{P_1} \right)$$

$$= (1.852 \text{ lbm/s}) \left(0.76964 - 0.59173 - (0.06855 \text{ Btu/lbm} \cdot \text{R}) \ln \frac{150 \text{ psia}}{15 \text{ psia}} \right) = 0.0372 \text{ Btu/s} \cdot \text{R}$$

Substituting, the rate of entropy generation during this process is determined to be

$$\dot{S}_{\text{gen}} = \dot{m}(s_2 - s_1) + \frac{\dot{Q}_{\text{out}}}{T_{\text{b,surr}}} = 0.0372 \text{ Btu/s} \cdot \text{R} + \frac{1500/60 \text{ Btu/s}}{520 \text{ R}} = \mathbf{0.0853 \text{ Btu/s} \cdot \text{R}}$$

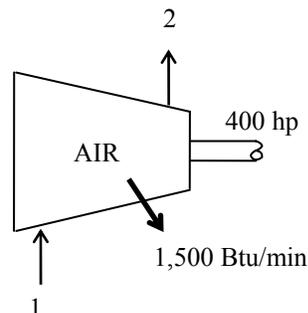

7-172 Steam is accelerated in a nozzle from a velocity of 70 m/s to 320 m/s. The exit temperature and the rate of entropy generation are to be determined.

Assumptions **1** This is a steady-flow process since there is no change with time. **2** Potential energy changes are negligible. **3** There are no work interactions. **4** The device is adiabatic and thus heat transfer is negligible.

Properties From the steam tables (Table A-6),

$$\left. \begin{array}{l} P_1 = 4 \text{ MPa} \\ T_1 = 450 \text{ }^\circ\text{C} \end{array} \right\} \begin{array}{l} h_1 = 3331.2 \text{ kJ/kg} \\ s_1 = 6.9386 \text{ kJ/kg} \cdot \text{K} \\ \nu_1 = 0.08004 \text{ m}^3/\text{kg} \end{array}$$

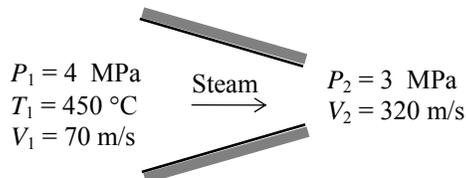

Analysis (a) There is only one inlet and one exit, and thus $\dot{m}_1 = \dot{m}_2 = \dot{m}$. We take nozzle as the system, which is a control volume since mass crosses the boundary. The energy balance for this steady-flow system can be expressed in the rate form as

$$\underbrace{\dot{E}_{\text{in}} - \dot{E}_{\text{out}}}_{\text{Rate of net energy transfer by heat, work, and mass}} = \underbrace{\Delta \dot{E}_{\text{system}}}_{\text{Rate of change in internal, kinetic, potential, etc. energies}} \stackrel{\neq 0 \text{ (steady)}}{=} 0$$

$$\dot{E}_{\text{in}} = \dot{E}_{\text{out}}$$

$$\dot{m}(h_1 + V_1^2/2) = \dot{m}(h_2 + V_2^2/2) \quad (\text{since } \dot{Q} \cong \dot{W} \cong \Delta \text{pe} \cong 0)$$

$$0 = h_2 - h_1 + \frac{V_2^2 - V_1^2}{2}$$

Substituting,,

$$\text{or,} \quad h_2 = 3331.2 \text{ kJ/kg} - \frac{(320 \text{ m/s})^2 - (70 \text{ m/s})^2}{2} \left(\frac{1 \text{ kJ/kg}}{1000 \text{ m}^2/\text{s}^2} \right) = 3282.4 \text{ kJ/kg}$$

Thus,

$$\left. \begin{array}{l} P_2 = 3 \text{ MPa} \\ h_{2a} = 3282.4 \text{ kJ/kg} \end{array} \right\} \begin{array}{l} T_2 = \mathbf{422.3}^\circ\text{C} \\ s_2 = 6.9976 \text{ kJ/kg} \cdot \text{K} \end{array}$$

The mass flow rate of steam is

$$\dot{m} = \frac{1}{\nu_1} A_1 V_1 = \frac{1}{0.08004 \text{ m}^3/\text{kg}} (7 \times 10^{-4} \text{ m}^2) (70 \text{ m/s}) = 0.6122 \text{ kg/s}$$

(b) Again we take the nozzle to be the system. Noting that no heat crosses the boundaries of this combined system, the entropy balance for it can be expressed as

$$\underbrace{\dot{S}_{\text{in}} - \dot{S}_{\text{out}}}_{\text{Rate of net entropy transfer by heat and mass}} + \underbrace{\dot{S}_{\text{gen}}}_{\text{Rate of entropy generation}} = \underbrace{\Delta \dot{S}_{\text{system}}}_{\text{Rate of change of entropy}} \stackrel{\neq 0}{=} 0$$

$$\dot{m}s_1 - \dot{m}s_2 + \dot{S}_{\text{gen}} = 0$$

$$\dot{S}_{\text{gen}} = \dot{m}(s_2 - s_1)$$

Substituting, the rate of entropy generation during this process is determined to be

$$\dot{S}_{\text{gen}} = \dot{m}(s_2 - s_1) = (0.6122 \text{ kg/s})(6.9976 - 6.9386) \text{ kJ/kg} \cdot \text{K} = \mathbf{0.0361 \text{ kW/K}}$$

Special Topic: Reducing the Cost of Compressed Air

7-173 The total installed power of compressed air systems in the US is estimated to be about 20 million horsepower. The amount of energy and money that will be saved per year if the energy consumed by compressors is reduced by 5 percent is to be determined.

Assumptions 1 The compressors operate at full load during one-third of the time on average, and are shut down the rest of the time. **2** The average motor efficiency is 85 percent.

Analysis The electrical energy consumed by compressors per year is

$$\begin{aligned}\text{Energy consumed} &= (\text{Power rating})(\text{Load factor})(\text{Annual Operating Hours})/\text{Motor efficiency} \\ &= (20 \times 10^6 \text{ hp})(0.746 \text{ kW/hp})(1/3)(365 \times 24 \text{ hours/year})/0.85 \\ &= 5.125 \times 10^{10} \text{ kWh/year}\end{aligned}$$

Then the energy and cost savings corresponding to a 5% reduction in energy use for compressed air become

$$\begin{aligned}\text{Energy Savings} &= (\text{Energy consumed})(\text{Fraction saved}) \\ &= (5.125 \times 10^{10} \text{ kWh})(0.05) \\ &= \mathbf{2.563 \times 10^9 \text{ kWh/year}}\end{aligned}$$

$$\begin{aligned}\text{Cost Savings} &= (\text{Energy savings})(\text{Unit cost of energy}) \\ &= (2.563 \times 10^9 \text{ kWh/year})(\$0.07/\text{kWh}) \\ &= \mathbf{\$0.179 \times 10^9 \text{ /year}}\end{aligned}$$

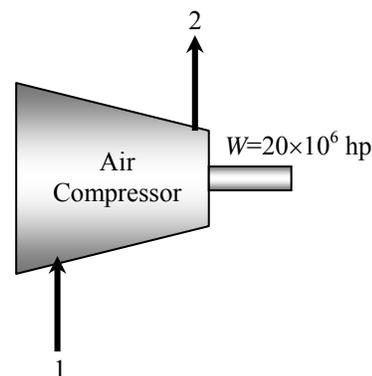

Therefore, reducing the energy usage of compressors by 5% will save \$179 million a year.

7-174 The total energy used to compress air in the US is estimated to be 0.5×10^{15} kJ per year. About 20% of the compressed air is estimated to be lost by air leaks. The amount and cost of electricity wasted per year due to air leaks is to be determined.

Assumptions About 20% of the compressed air is lost by air leaks.

Analysis The electrical energy and money wasted by air leaks are

$$\begin{aligned}\text{Energy wasted} &= (\text{Energy consumed})(\text{Fraction wasted}) \\ &= (0.5 \times 10^{15} \text{ kJ})(1 \text{ kWh}/3600 \text{ kJ})(0.20) \\ &= \mathbf{27.78 \times 10^9 \text{ kWh/year}}\end{aligned}$$

$$\begin{aligned}\text{Money wasted} &= (\text{Energy wasted})(\text{Unit cost of energy}) \\ &= (27.78 \times 10^9 \text{ kWh/year})(\$0.07/\text{kWh}) \\ &= \mathbf{\$1.945 \times 10^9 \text{ /year}}\end{aligned}$$

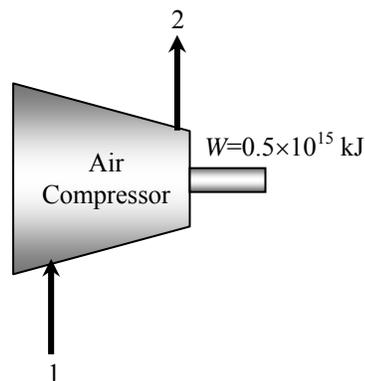

Therefore, air leaks are costing almost \$2 billion a year in electricity costs. The environment also suffers from this because of the pollution associated with the generation of this much electricity.

7-175 The compressed air requirements of a plant is being met by a 125 hp compressor that compresses air from 101.3 kPa to 900 kPa. The amount of energy and money saved by reducing the pressure setting of compressed air to 750 kPa is to be determined.

Assumptions **1** Air is an ideal gas with constant specific heats. **2** Kinetic and potential energy changes are negligible. **3** The load factor of the compressor is given to be 0.75. **4** The pressures given are absolute pressure rather than gage pressure.

Properties The specific heat ratio of air is $k = 1.4$ (Table A-2).

Analysis The electrical energy consumed by this compressor per year is

$$\begin{aligned} \text{Energy consumed} &= (\text{Power rating})(\text{Load factor})(\text{Annual Operating Hours})/\text{Motor efficiency} \\ &= (125 \text{ hp})(0.746 \text{ kW/hp})(0.75)(3500 \text{ hours/year})/0.88 \\ &= 278,160 \text{ kWh/year} \end{aligned}$$

The fraction of energy saved as a result of reducing the pressure setting of the compressor is

$$\begin{aligned} \text{Power Reduction Factor} &= 1 - \frac{(P_{2,\text{reduced}}/P_1)^{(k-1)/k} - 1}{(P_2/P_1)^{(k-1)/k} - 1} \\ &= 1 - \frac{(750/101.3)^{(1.4-1)/1.4} - 1}{(900/101.3)^{(1.4-1)/1.4} - 1} \\ &= 0.1093 \end{aligned}$$

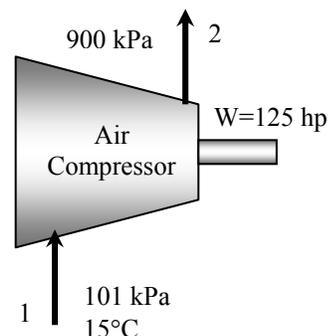

That is, reducing the pressure setting will result in about 11 percent savings from the energy consumed by the compressor and the associated cost. Therefore, the energy and cost savings in this case become

$$\begin{aligned} \text{Energy Savings} &= (\text{Energy consumed})(\text{Power reduction factor}) \\ &= (278,160 \text{ kWh/year})(0.1093) \\ &= \mathbf{30,410 \text{ kWh/year}} \end{aligned}$$

$$\begin{aligned} \text{Cost Savings} &= (\text{Energy savings})(\text{Unit cost of energy}) \\ &= (30,410 \text{ kWh/year})(\$0.085/\text{kWh}) \\ &= \mathbf{\$2585/\text{year}} \end{aligned}$$

Therefore, reducing the pressure setting by 150 kPa will result in annual savings of 30.410 kWh that is worth \$2585 in this case.

Discussion Some applications require very low pressure compressed air. In such cases the need can be met by a blower instead of a compressor. Considerable energy can be saved in this manner, since a blower requires a small fraction of the power needed by a compressor for a specified mass flow rate.

7-176 A 150 hp compressor in an industrial facility is housed inside the production area where the average temperature during operating hours is 25°C. The amounts of energy and money saved as a result of drawing cooler outside air to the compressor instead of using the inside air are to be determined.

Assumptions **1** Air is an ideal gas with constant specific heats. **2** Kinetic and potential energy changes are negligible.

Analysis The electrical energy consumed by this compressor per year is

$$\begin{aligned} \text{Energy consumed} &= (\text{Power rating})(\text{Load factor})(\text{Annual Operating Hours})/\text{Motor efficiency} \\ &= (150 \text{ hp})(0.746 \text{ kW/hp})(0.85)(4500 \text{ hours/year})/0.9 \\ &= 475,384 \text{ kWh/year} \end{aligned}$$

Also,

$$\begin{aligned} \text{Cost of Energy} &= (\text{Energy consumed})(\text{Unit cost of energy}) \\ &= (475,384 \text{ kWh/year})(\$0.07/\text{kWh}) \\ &= \$33,277/\text{year} \end{aligned}$$

The fraction of energy saved as a result of drawing in cooler outside air is

$$\text{Power Reduction Factor} = 1 - \frac{T_{\text{outside}}}{T_{\text{inside}}} = 1 - \frac{10 + 273}{25 + 273} = 0.0503$$

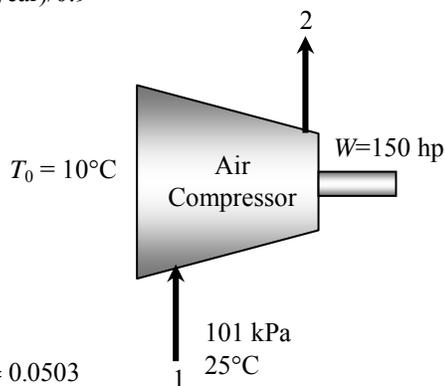

That is, drawing in air which is 15°C cooler will result in 5.03 percent savings from the energy consumed by the compressor and the associated cost. Therefore, the energy and cost savings in this case become

$$\begin{aligned} \text{Energy Savings} &= (\text{Energy consumed})(\text{Power reduction factor}) \\ &= (475,384 \text{ kWh/year})(0.0503) \\ &= \mathbf{23,929 \text{ kWh/year}} \end{aligned}$$

$$\begin{aligned} \text{Cost Savings} &= (\text{Energy savings})(\text{Unit cost of energy}) \\ &= (23,929 \text{ kWh/year})(\$0.07/\text{kWh}) \\ &= \mathbf{\$1675/\text{year}} \end{aligned}$$

Therefore, drawing air in from the outside will result in annual savings of 23,929 kWh, which is worth \$1675 in this case.

Discussion The price of a typical 150 hp compressor is much lower than \$50,000. Therefore, it is interesting to note that the cost of energy a compressor uses a year may be more than the cost of the compressor itself.

The implementation of this measure requires the installation of an ordinary sheet metal or PVC duct from the compressor intake to the outside. The installation cost associated with this measure is relatively low, and the pressure drop in the duct in most cases is negligible. About half of the manufacturing facilities we have visited, especially the newer ones, have the duct from the compressor intake to the outside in place, and they are already taking advantage of the savings associated with this measure.

7-177 The compressed air requirements of the facility during 60 percent of the time can be met by a 25 hp reciprocating compressor instead of the existing 100 hp compressor. The amounts of energy and money saved as a result of switching to the 25 hp compressor during 60 percent of the time are to be determined.

Analysis Noting that 1 hp = 0.746 kW, the electrical energy consumed by each compressor per year is determined from

$$\begin{aligned} (\text{Energy consumed})_{\text{Large}} &= (\text{Power})(\text{Hours})[(\text{LFxTF}/\eta_{\text{motor}})_{\text{Unloaded}} + (\text{LFxTF}/\eta_{\text{motor}})_{\text{Loaded}}] \\ &= (100 \text{ hp})(0.746 \text{ kW/hp})(3800 \text{ hours/year})[0.35 \times 0.6/0.82 + 0.90 \times 0.4/0.9] \\ &= 185,990 \text{ kWh/year} \end{aligned}$$

$$\begin{aligned} (\text{Energy consumed})_{\text{Small}} &= (\text{Power})(\text{Hours})[(\text{LFxTF}/\eta_{\text{motor}})_{\text{Unloaded}} + (\text{LFxTF}/\eta_{\text{motor}})_{\text{Loaded}}] \\ &= (25 \text{ hp})(0.746 \text{ kW/hp})(3800 \text{ hours/year})[0.0 \times 0.15 + 0.95 \times 0.85]/0.88 \\ &= 65,031 \text{ kWh/year} \end{aligned}$$

Therefore, the energy and cost savings in this case become

$$\begin{aligned} \text{Energy Savings} &= (\text{Energy consumed})_{\text{Large}} - (\text{Energy consumed})_{\text{Small}} \\ &= 185,990 - 65,031 \text{ kWh/year} \\ &= \mathbf{120,959 \text{ kWh/year}} \end{aligned}$$

$$\begin{aligned} \text{Cost Savings} &= (\text{Energy savings})(\text{Unit cost of energy}) \\ &= (120,959 \text{ kWh/year})(\$0.075/\text{kWh}) \\ &= \mathbf{\$9,072/\text{year}} \end{aligned}$$

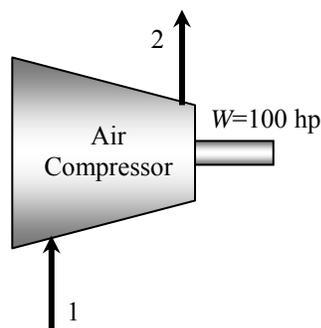

Discussion Note that utilizing a small compressor during the times of reduced compressed air requirements and shutting down the large compressor will result in annual savings of 120,959 kWh, which is worth \$9,072 in this case.

7-178 A facility stops production for one hour every day, including weekends, for lunch break, but the 125 hp compressor is kept operating. If the compressor consumes 35 percent of the rated power when idling, the amounts of energy and money saved per year as a result of turning the compressor off during lunch break are to be determined.

Analysis It seems like the compressor in this facility is kept on unnecessarily for one hour a day and thus 365 hours a year, and the idle factor is 0.35. Then the energy and cost savings associated with turning the compressor off during lunch break are determined to be

$$\begin{aligned}\text{Energy Savings} &= (\text{Power Rating})(\text{Turned Off Hours})(\text{Idle Factor})/\eta_{\text{motor}} \\ &= (125 \text{ hp})(0.746 \text{ kW/hp})(365 \text{ hours/year})(0.35)/0.84 \\ &= \mathbf{14,182 \text{ kWh/year}}\end{aligned}$$

$$\begin{aligned}\text{Cost Savings} &= (\text{Energy savings})(\text{Unit cost of energy}) \\ &= (14,182 \text{ kWh/year})(\$0.09/\text{kWh}) \\ &= \mathbf{\$1,276/\text{year}}\end{aligned}$$

Discussion Note that the simple practice of turning the compressor off during lunch break will save this facility \$1,276 a year in energy costs. There are also side benefits such as extending the life of the motor and the compressor, and reducing the maintenance costs.

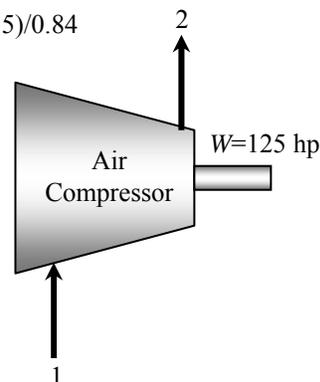

7-179 It is determined that 40 percent of the energy input to the compressor is removed from the compressed air as heat in the aftercooler with a refrigeration unit whose COP is 3.5. The amounts of the energy and money saved per year as a result of cooling the compressed air before it enters the refrigerated dryer are to be determined.

Assumptions The compressor operates at full load when operating.

Analysis Noting that 40 percent of the energy input to the compressor is removed by the aftercooler, the rate of heat removal from the compressed air in the aftercooler under full load conditions is

$$\begin{aligned}\dot{Q}_{\text{aftercooling}} &= (\text{Rated Power of Compressor})(\text{Load Factor})(\text{Aftercooling Fraction}) \\ &= (150 \text{ hp})(0.746 \text{ kW/hp})(1.0)(0.4) = 44.76 \text{ kW}\end{aligned}$$

The compressor is said to operate at full load for 1600 hours a year, and the COP of the refrigeration unit is 3.5. Then the energy and cost savings associated with this measure become

$$\begin{aligned}\text{Energy Savings} &= (\dot{Q}_{\text{aftercooling}})(\text{Annual Operating Hours})/\text{COP} \\ &= (44.76 \text{ kW})(1600 \text{ hours/year})/3.5 \\ &= \mathbf{20,462 \text{ kWh/year}}\end{aligned}$$

$$\begin{aligned}\text{Cost Savings} &= (\text{Energy savings})(\text{Unit cost of energy saved}) \\ &= (20,462 \text{ kWh/year})(\$0.06/\text{kWh}) \\ &= \mathbf{\$1227/\text{year}}\end{aligned}$$

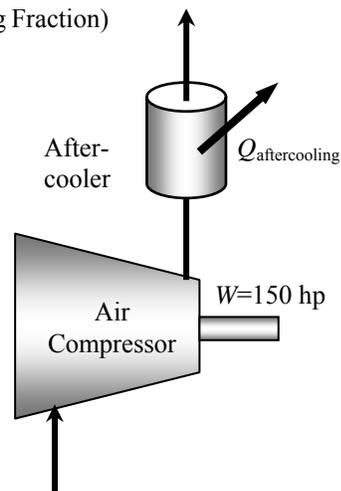

Discussion Note that the aftercooler will save this facility 20,462 kWh of electrical energy worth \$1227 per year. The actual savings will be less than indicated above since we have not considered the power consumed by the fans and/or pumps of the aftercooler. However, if the heat removed by the aftercooler is utilized for some useful purpose such as space heating or process heating, then the actual savings will be much more.

7-180 The motor of a 150 hp compressor is burned out and is to be replaced by either a 93% efficient standard motor or a 96.2% efficient high efficiency motor. It is to be determined if the savings from the high efficiency motor justify the price differential.

Assumptions **1** The compressor operates at full load when operating. **2** The life of the motors is 10 years. **3** There are no rebates involved. **4** The price of electricity remains constant.

Analysis The energy and cost savings associated with the installation of the high efficiency motor in this case are determined to be

$$\begin{aligned}\text{Energy Savings} &= (\text{Power Rating})(\text{Operating Hours})(\text{Load Factor})(1/\eta_{\text{standard}} - 1/\eta_{\text{efficient}}) \\ &= (150 \text{ hp})(0.746 \text{ kW/hp})(4,368 \text{ hours/year})(1.0)(1/0.930 - 1/0.962) \\ &= \mathbf{17,483 \text{ kWh/year}}\end{aligned}$$

$$\begin{aligned}\text{Cost Savings} &= (\text{Energy savings})(\text{Unit cost of energy}) \\ &= (17,483 \text{ kWh/year})(\$0.075/\text{kWh}) \\ &= \mathbf{\$1311/\text{year}}\end{aligned}$$

The additional cost of the energy efficient motor is

$$\text{Cost Differential} = \$10,942 - \$9,031 = \$1,911$$

Discussion The money saved by the high efficiency motor will pay for this cost difference in $\$1,911/\$1311 = 1.5$ years, and will continue saving the facility money for the rest of the 10 years of its lifetime. Therefore, the use of the high efficiency motor is recommended in this case even in the absence of any incentives from the local utility company.

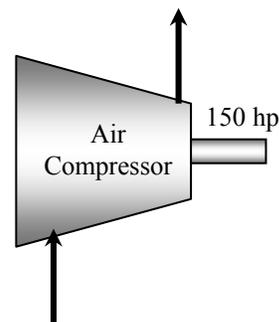

7-181 The compressor of a facility is being cooled by air in a heat-exchanger. This air is to be used to heat the facility in winter. The amount of money that will be saved by diverting the compressor waste heat into the facility during the heating season is to be determined.

Assumptions The compressor operates at full load when operating.

Analysis Assuming operation at sea level and taking the density of air to be 1.2 kg/m^3 , the mass flow rate of air through the liquid-to-air heat exchanger is determined to be

$$\begin{aligned}\text{Mass flow rate of air} &= (\text{Density of air})(\text{Average velocity})(\text{Flow area}) \\ &= (1.2 \text{ kg/m}^3)(3 \text{ m/s})(1.0 \text{ m}^2) \\ &= 3.6 \text{ kg/s} = 12,960 \text{ kg/h}\end{aligned}$$

Noting that the temperature rise of air is 32°C , the rate at which heat can be recovered (or the rate at which heat is transferred to air) is

$$\begin{aligned}\text{Rate of Heat Recovery} &= (\text{Mass flow rate of air})(\text{Specific heat of air})(\text{Temperature rise}) \\ &= (12,960 \text{ kg/h})(1.0 \text{ kJ/kg}\cdot^\circ\text{C})(32^\circ\text{C}) \\ &= 414,720 \text{ kJ/h}\end{aligned}$$

The number of operating hours of this compressor during the heating season is

$$\begin{aligned}\text{Operating hours} &= (20 \text{ hours/day})(5 \text{ days/week})(26 \text{ weeks/year}) \\ &= 2600 \text{ hours/year}\end{aligned}$$

Then the annual energy and cost savings become

$$\begin{aligned}\text{Energy Savings} &= (\text{Rate of Heat Recovery})(\text{Annual Operating Hours})/\text{Efficiency} \\ &= (414,720 \text{ kJ/h})(2600 \text{ hours/year})/0.8 \\ &= 1,347,840,000 \text{ kJ/year} \\ &= 12,776 \text{ therms/year}\end{aligned}$$

$$\begin{aligned}\text{Cost Savings} &= (\text{Energy savings})(\text{Unit cost of energy saved}) \\ &= (12,776 \text{ therms/year})(\$1.0/\text{therm}) \\ &= \mathbf{\$12,776/\text{year}}\end{aligned}$$

Therefore, utilizing the waste heat from the compressor will save \$12,776 per year from the heating costs.

Discussion The implementation of this measure requires the installation of an ordinary sheet metal duct from the outlet of the heat exchanger into the building. The installation cost associated with this measure is relatively low. A few of the manufacturing facilities we have visited already have this conservation system in place. A damper is used to direct the air into the building in winter and to the ambient in summer.

Combined compressor/heat-recovery systems are available in the market for both air-cooled (greater than 50 hp) and water cooled (greater than 125 hp) systems.

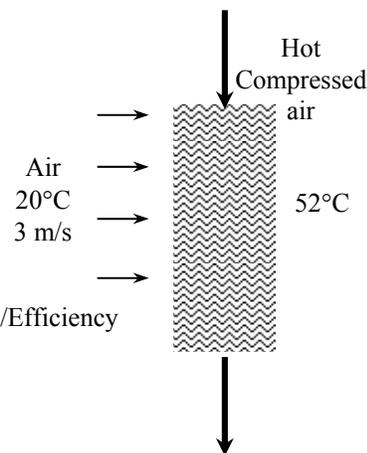

7-182 The compressed air lines in a facility are maintained at a gage pressure of 850 kPa at a location where the atmospheric pressure is 85.6 kPa. There is a 5-mm diameter hole on the compressed air line. The energy and money saved per year by sealing the hole on the compressed air line.

Assumptions 1 Air is an ideal gas with constant specific heats. **2** Kinetic and potential energy changes are negligible.

Properties The gas constant of air is $R = 0.287 \text{ kJ/kg}\cdot\text{K}$. The specific heat ratio of air is $k = 1.4$ (Table A-2).

Analysis Disregarding any pressure losses and noting that the absolute pressure is the sum of the gage pressure and the atmospheric pressure, the work needed to compress a unit mass of air at 15°C from the atmospheric pressure of 85.6 kPa to $850+85.6 = 935.6 \text{ kPa}$ is determined to be

$$\begin{aligned} w_{\text{comp, in}} &= \frac{kRT_1}{\eta_{\text{comp}}(k-1)} \left[\left(\frac{P_2}{P_1} \right)^{(k-1)/k} - 1 \right] \\ &= \frac{(1.4)(0.287 \text{ kJ/kg}\cdot\text{K})(288 \text{ K})}{(0.8)(1.4-1)} \left[\left(\frac{935.6 \text{ kPa}}{85.6 \text{ kPa}} \right)^{(1.4-1)/1.4} - 1 \right] \\ &= 354.5 \text{ kJ/kg} \end{aligned}$$

The cross-sectional area of the 5-mm diameter hole is

$$A = \pi D^2 / 4 = \pi(5 \times 10^{-3} \text{ m})^2 / 4 = 19.63 \times 10^{-6} \text{ m}^2$$

Noting that the line conditions are $T_0 = 298 \text{ K}$ and $P_0 = 935.6 \text{ kPa}$, the mass flow rate of the air leaking through the hole is determined to be

$$\begin{aligned} \dot{m}_{\text{air}} &= C_{\text{loss}} \left(\frac{2}{k+1} \right)^{1/(k-1)} \frac{P_0}{RT_0} A \sqrt{kR \left(\frac{2}{k+1} \right) T_0} \\ &= (0.65) \left(\frac{2}{1.4+1} \right)^{1/(1.4-1)} \frac{935.6 \text{ kPa}}{(0.287 \text{ kPa}\cdot\text{m}^3 / \text{kg}\cdot\text{K})(298 \text{ K})} (19.63 \times 10^{-6} \text{ m}^2) \\ &\quad \times \sqrt{(1.4)(0.287 \text{ kJ/kg}\cdot\text{K}) \left(\frac{1000 \text{ m}^2 / \text{s}^2}{1 \text{ kJ/kg}} \right) \left(\frac{2}{1.4+1} \right) (298 \text{ K})} \\ &= 0.02795 \text{ kg/s} \end{aligned}$$

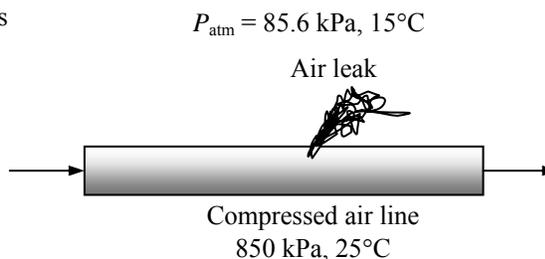

Then the power wasted by the leaking compressed air becomes

$$\text{Power wasted} = \dot{m}_{\text{air}} w_{\text{comp, in}} = (0.02795 \text{ kg/s})(354.5 \text{ kJ/kg}) = 9.91 \text{ kW}$$

Noting that the compressor operates 4200 hours a year and the motor efficiency is 0.93, the annual energy and cost savings resulting from repairing this leak are determined to be

$$\begin{aligned} \text{Energy Savings} &= (\text{Power wasted})(\text{Annual operating hours})/\text{Motor efficiency} \\ &= (9.91 \text{ kW})(4200 \text{ hours/year})/0.93 \\ &= \mathbf{44,755 \text{ kWh/year}} \end{aligned}$$

$$\begin{aligned} \text{Cost Savings} &= (\text{Energy savings})(\text{Unit cost of energy}) \\ &= (44,755 \text{ kWh/year})(\$0.07/\text{kWh}) \\ &= \mathbf{\$3133/year} \end{aligned}$$

Therefore, the facility will save 44,755 kWh of electricity that is worth \$3133 a year when this air leak is sealed.

Review Problems

7-183E The source and sink temperatures and the thermal efficiency of a heat engine are given. The entropy change of the two reservoirs is to be calculated and it is to be determined if this engine satisfies the increase of entropy principle.

Assumptions The heat engine operates steadily.

Analysis According to the first law and the definition of the thermal efficiency,

$$Q_L = (1 - \eta)Q_H = (1 - 0.4)(1 \text{ Btu}) = 0.6 \text{ Btu}$$

when the thermal efficiency is 40%. The entropy change of everything involved in this process is then

$$\begin{aligned} \Delta S_{\text{total}} &= \Delta S_H + \Delta S_L \\ &= \frac{Q_H}{T_H} + \frac{Q_L}{T_L} = \frac{-1 \text{ Btu}}{1300 \text{ R}} + \frac{0.6 \text{ Btu}}{500 \text{ R}} = \mathbf{0.000431 \text{ Btu/R}} \end{aligned}$$

Since the entropy of everything has increased, this engine is possible. When the thermal efficiency of the engine is 70%,

$$Q_L = (1 - \eta)Q_H = (1 - 0.7)(1 \text{ Btu}) = 0.3 \text{ Btu}$$

The total entropy change is then

$$\begin{aligned} \Delta S_{\text{total}} &= \Delta S_H + \Delta S_L \\ &= \frac{Q_H}{T_H} + \frac{Q_L}{T_L} = \frac{-1 \text{ Btu}}{1300 \text{ R}} + \frac{0.3 \text{ Btu}}{500 \text{ R}} = \mathbf{-0.000169 \text{ Btu/R}} \end{aligned}$$

which is a decrease in the entropy of everything involved with this engine. Therefore, this engine is now impossible.

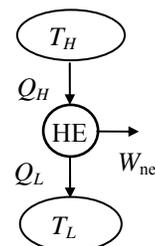

7-184 The source and sink temperatures and the COP of a refrigerator are given. The total entropy change of the two reservoirs is to be calculated and it is to be determined if this refrigerator satisfies the second law.

Assumptions The refrigerator operates steadily.

Analysis Combining the first law and the definition of the coefficient of performance produces

$$Q_H = Q_L \left(1 + \frac{1}{\text{COP}_R} \right) = (1 \text{ kJ}) \left(1 + \frac{1}{4} \right) = 1.25 \text{ kJ}$$

when $\text{COP} = 4$. The entropy change of everything is then

$$\begin{aligned} \Delta S_{\text{total}} &= \Delta S_H + \Delta S_L \\ &= \frac{Q_H}{T_H} + \frac{Q_L}{T_L} = \frac{1.25 \text{ kJ}}{303 \text{ K}} + \frac{-1 \text{ kJ}}{253 \text{ K}} = \mathbf{0.000173 \text{ kJ/K}} \end{aligned}$$

Since the entropy increases, a refrigerator with $\text{COP} = 4$ is possible. When the coefficient of performance is increased to 6,

$$Q_H = Q_L \left(1 + \frac{1}{\text{COP}_R} \right) = (1 \text{ kJ}) \left(1 + \frac{1}{6} \right) = 1.167 \text{ kJ}$$

and the net entropy change is

$$\begin{aligned} \Delta S_{\text{total}} &= \Delta S_H + \Delta S_L \\ &= \frac{Q_H}{T_H} + \frac{Q_L}{T_L} = \frac{1.167 \text{ kJ}}{303 \text{ K}} + \frac{-1 \text{ kJ}}{253 \text{ K}} = \mathbf{-0.000101 \text{ kJ/K}} \end{aligned}$$

and the refrigerator can no longer be possible.

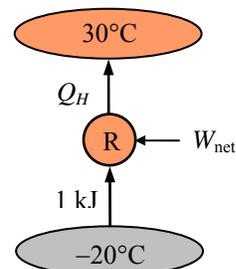

7-185 The operating conditions and thermal reservoir temperatures of a heat pump are given. It is to be determined if the increase of entropy principle is satisfied.

Assumptions The heat pump operates steadily.

Analysis Applying the first law to the cyclic heat pump gives

$$\dot{Q}_L = \dot{Q}_H - \dot{W}_{\text{net,in}} = 25 \text{ kW} - 5 \text{ kW} = 20 \text{ kW}$$

According to the definition of the entropy, the rate at which the entropy of the high-temperature reservoir increases is

$$\Delta \dot{S}_H = \frac{\dot{Q}_H}{T_H} = \frac{25 \text{ kW}}{300 \text{ K}} = 0.0833 \text{ kW/K}$$

Similarly, the rate at which the entropy of the low-temperature reservoir decreases is

$$\Delta \dot{S}_L = \frac{\dot{Q}_L}{T_L} = \frac{-20 \text{ kW}}{260 \text{ K}} = -0.0769 \text{ kW/K}$$

The rate at which the entropy of everything changes is then

$$\Delta \dot{S}_{\text{total}} = \Delta \dot{S}_H + \Delta \dot{S}_L = 0.0833 - 0.0769 = 0.0064 \text{ kW/K}$$

which is positive and therefore it **satisfies** the increase in entropy principle.

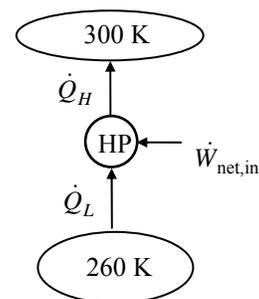

7-186 Steam is expanded adiabatically in a closed system. The minimum internal energy that can be achieved during this process is to be determined.

Analysis The entropy at the initial state is

$$\left. \begin{array}{l} P_1 = 1500 \text{ kPa} \\ T_1 = 320^\circ\text{C} \end{array} \right\} s_1 = 6.9957 \text{ kJ/kg} \cdot \text{K} \quad (\text{from Table A - 6 or from EES})$$

The internal energy will be minimum if the process is isentropic. Then,

$$\left. \begin{array}{l} P_2 = 100 \text{ kPa} \\ s_2 = s_1 = 6.9957 \text{ kJ/kg} \cdot \text{K} \end{array} \right\} \begin{array}{l} x_2 = \frac{s_2 - s_f}{s_{fg}} = \frac{6.9957 - 1.3028}{6.0562} = 0.9400 \\ u_2 = u_f + x_2 u_{fg} = 417.40 + (0.9400)(2088.2) = \mathbf{2380.3 \text{ kJ/kg}} \end{array}$$

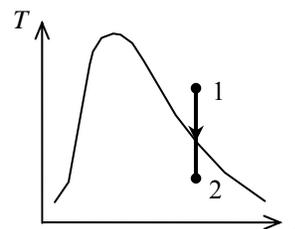

7-187E Water is expanded in an isothermal, reversible process. It is to be determined if the process is possible.

Analysis The entropies at the initial and final states are (Tables A-5E and A-6E)

$$\left. \begin{array}{l} P_1 = 30 \text{ psia} \\ x_1 = 0.70 \end{array} \right\} \begin{array}{l} T_1 = 250.3^\circ\text{F} \\ s_1 = s_f + x_1 s_{fg} = 0.36821 + (0.70)(1.33132) = 1.3001 \text{ Btu/lbm} \cdot \text{R} \end{array}$$

$$\left. \begin{array}{l} P_2 = 10 \text{ psia} \\ T_2 = T_1 = 250.3^\circ\text{F} \end{array} \right\} s_2 = 1.8277 \text{ Btu/lbm} \cdot \text{R}$$

The heat transfer during this isothermal, reversible process is the area under the process line:

$$\begin{aligned} q &= T(s_2 - s_1) \\ &= (250 + 460 \text{ K})(1.8277 - 1.3001) \text{ Btu/lbm} \cdot \text{R} \\ &= 374.6 \text{ Btu/lbm} \end{aligned}$$

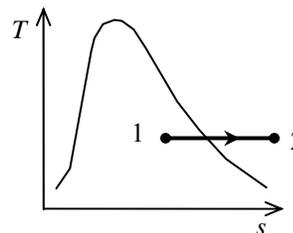

The total entropy change (i.e., entropy generation) is the sum of the entropy changes of water and the reservoir:

$$\begin{aligned} \Delta s_{\text{total}} &= \Delta s_{\text{water}} + \Delta s_{\text{R}} \\ &= s_2 - s_1 + \frac{-q}{T_{\text{R}}} \\ &= (1.8277 - 1.3001) \text{ Btu/lbm} \cdot \text{R} + \frac{-374.6 \text{ Btu/lbm}}{(300 + 460) \text{ R}} \\ &= \mathbf{0.0347 \text{ Btu/lbm} \cdot \text{R}} \end{aligned}$$

Note that the sign of heat transfer is with respect to the reservoir.

7-188E Air is compressed adiabatically in a closed system. It is to be determined if this process is possible.

Assumptions 1 Changes in the kinetic and potential energies are negligible. **4** Air is an ideal gas with constant specific heats.

Properties The properties of air at room temperature are $R = 0.3704 \text{ psia}\cdot\text{ft}^3/\text{lbm}\cdot\text{R}$, $c_p = 0.240 \text{ Btu}/\text{lbm}\cdot\text{R}$ (Table A-2Ea).

Analysis The specific volume of air at the initial state is

$$\nu_1 = \frac{RT_1}{P_1} = \frac{(0.3704 \text{ psia}\cdot\text{ft}^3/\text{lbm}\cdot\text{R})(560 \text{ R})}{16 \text{ psia}} = 12.96 \text{ ft}^3/\text{lbm}$$

The volume at the final state will be minimum if the process is isentropic. The specific volume for this case is determined from the isentropic relation of an ideal gas to be

$$\nu_{2,\min} = \nu_1 \left(\frac{P_1}{P_2} \right)^{1/k} = (12.96 \text{ ft}^3/\text{lbm}) \left(\frac{16 \text{ psia}}{100 \text{ psia}} \right)^{1/1.4} = 3.500 \text{ ft}^3/\text{lbm}$$

and the minimum volume is

$$\nu_2 = m\nu_2 = (2 \text{ lbm})(3.500 \text{ ft}^3/\text{lbm}) = \mathbf{7.00 \text{ ft}^3}$$

which is greater than the proposed volume $4 \text{ ft}^3/\text{lbm}$. Hence, it is not possible to compress this air into $4 \text{ ft}^3/\text{lbm}$.

7-189 Oxygen is expanded adiabatically in a piston-cylinder device. The maximum volume is to be determined.

Assumptions 1 Changes in the kinetic and potential energies are negligible. **4** Oxygen is an ideal gas with constant specific heats.

Properties The gas constant of oxygen is $R = 0.2598 \text{ kPa}\cdot\text{m}^3/\text{kg}\cdot\text{K}$. The specific heat ratio at the room temperature is $k = 1.395$ (Table A-2a).

Analysis The volume of oxygen at the initial state is

$$\nu_1 = \frac{mRT_1}{P_1} = \frac{(3 \text{ kg})(0.2598 \text{ kPa}\cdot\text{m}^3/\text{kg}\cdot\text{K})(373 + 273 \text{ K})}{950 \text{ kPa}} = 0.5300 \text{ m}^3$$

The volume at the final state will be maximum if the process is isentropic. The volume for this case is determined from the isentropic relation of an ideal gas to be

$$\nu_{2,\max} = \nu_1 \left(\frac{P_1}{P_2} \right)^{1/k} = (0.5300 \text{ m}^3) \left(\frac{950 \text{ kPa}}{100 \text{ kPa}} \right)^{1/1.395} = \mathbf{2.66 \text{ m}^3}$$

7-190E A solid block is heated with saturated water vapor. The final temperature of the block and water, and the entropy changes of the block, water, and the entire system are to be determined.

Assumptions **1** The system is stationary and thus the kinetic and potential energy changes are zero. **2** There are no work interactions involved. **3** There is no heat transfer between the system and the surroundings.

Analysis (a) As the block is heated, some of the water vapor will be condensed. We will assume (will be checked later) that the water is a mixture of liquid and vapor at the end of the process. Based upon this assumption, the final temperature of the water and solid block is **212°F** (The saturation temperature at 14.7 psia). The heat picked up by the block is

$$Q_{\text{block}} = mc(T_2 - T_1) = (100 \text{ lbm})(0.5 \text{ Btu/lbm} \cdot \text{R})(212 - 70)\text{R} = 7100 \text{ Btu}$$

The water properties at the initial state are

$$\left. \begin{array}{l} P_1 = 14.7 \text{ psia} \\ x_1 = 1 \end{array} \right\} \begin{array}{l} T_1 = 212^\circ\text{F} \\ h_1 = 1150.3 \text{ Btu/lbm} \\ s_1 = 1.7566 \text{ Btu/lbm} \cdot \text{R} \end{array} \quad (\text{Table A-5E})$$

The heat released by the water is equal to the heat picked up by the block. Also noting that the pressure of water remains constant, the enthalpy of water at the end of the heat exchange process is determined from

$$h_2 = h_1 - \frac{Q_{\text{water}}}{m_w} = 1150.3 \text{ Btu/lbm} - \frac{7100 \text{ Btu}}{10 \text{ lbm}} = 440.3 \text{ Btu/lbm}$$

The state of water at the final state is saturated mixture. Thus, our initial assumption was correct. The properties of water at the final state are

$$\left. \begin{array}{l} P_2 = 14.7 \text{ psia} \\ h_2 = 440.3 \text{ Btu/lbm} \end{array} \right\} \begin{array}{l} x_2 = \frac{h_2 - h_f}{h_{fg}} = \frac{440.3 - 180.16}{970.12} = 0.2682 \\ s_2 = s_f + x_2 s_{fg} = 0.31215 + (0.2682)(1.44441) = 0.69947 \text{ Btu/lbm} \cdot \text{R} \end{array}$$

The entropy change of the water is then

$$\Delta S_{\text{water}} = m_w(s_2 - s_1) = (10 \text{ lbm})(0.69947 - 1.7566)\text{Btu/lbm} = \mathbf{-10.57 \text{ Btu/R}}$$

(b) The entropy change of the block is

$$\Delta S_{\text{block}} = mc \ln \frac{T_2}{T_1} = (100 \text{ lbm})(0.5 \text{ Btu/lbm} \cdot \text{R}) \ln \frac{(212 + 460)\text{R}}{(70 + 460)\text{R}} = \mathbf{11.87 \text{ Btu/R}}$$

(c) The total entropy change is

$$\Delta S_{\text{total}} = S_{\text{gen}} = \Delta S_{\text{water}} + \Delta S_{\text{block}} = -10.57 + 11.87 = \mathbf{1.30 \text{ Btu/R}}$$

The positive result for the total entropy change (i.e., entropy generation) indicates that this process is possible.

7-191 Air is compressed in a piston-cylinder device. It is to be determined if this process is possible.

Assumptions 1 Changes in the kinetic and potential energies are negligible. **4** Air is an ideal gas with constant specific heats. **3** The compression process is reversible.

Properties The properties of air at room temperature are $R = 0.287 \text{ kPa}\cdot\text{m}^3/\text{kg}\cdot\text{K}$, $c_p = 1.005 \text{ kJ}/\text{kg}\cdot\text{K}$ (Table A-2a).

Analysis We take the contents of the cylinder as the system. This is a closed system since no mass enters or leaves. The energy balance for this stationary closed system can be expressed as

$$\underbrace{E_{\text{in}} - E_{\text{out}}}_{\substack{\text{Net energy transfer} \\ \text{by heat, work, and mass}}} = \underbrace{\Delta E_{\text{system}}}_{\substack{\text{Change in internal, kinetic,} \\ \text{potential, etc. energies}}}$$

$$W_{b,\text{in}} - Q_{\text{out}} = \Delta U = m(u_2 - u_1)$$

$$W_{b,\text{in}} - Q_{\text{out}} = mc_p(T_2 - T_1)$$

$$W_{b,\text{in}} - Q_{\text{out}} = 0 \quad (\text{since } T_2 = T_1)$$

$$Q_{\text{out}} = W_{b,\text{in}}$$

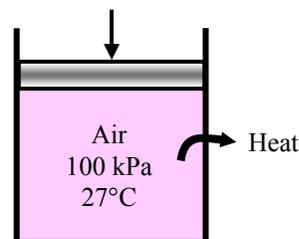

The work input for this isothermal, reversible process is

$$w_{\text{in}} = RT \ln \frac{P_2}{P_1} = (0.287 \text{ kJ}/\text{kg}\cdot\text{K})(300 \text{ K}) \ln \frac{250 \text{ kPa}}{100 \text{ kPa}} = 78.89 \text{ kJ}/\text{kg}$$

That is,

$$q_{\text{out}} = w_{\text{in}} = 78.89 \text{ kJ}/\text{kg}$$

The entropy change of air during this isothermal process is

$$\Delta s_{\text{air}} = c_p \ln \frac{T_2}{T_1} - R \ln \frac{P_2}{P_1} = -R \ln \frac{P_2}{P_1} = -(0.287 \text{ kJ}/\text{kg}\cdot\text{K}) \ln \frac{250 \text{ kPa}}{100 \text{ kPa}} = -0.2630 \text{ kJ}/\text{kg}\cdot\text{K}$$

The entropy change of the reservoir is

$$\Delta s_{\text{R}} = \frac{q_{\text{R}}}{T_{\text{R}}} = \frac{78.89 \text{ kJ}/\text{kg}}{300 \text{ K}} = 0.2630 \text{ kJ}/\text{kg}\cdot\text{K}$$

Note that the sign of heat transfer is taken with respect to the reservoir. The total entropy change (i.e., entropy generation) is the sum of the entropy changes of air and the reservoir:

$$\Delta s_{\text{total}} = \Delta s_{\text{air}} + \Delta s_{\text{R}} = -0.2630 + 0.2630 = \mathbf{0 \text{ kJ}/\text{kg}\cdot\text{K}}$$

Not only this process is possible but also completely reversible.

7-192 A paddle wheel does work on the water contained in a rigid tank. For a zero entropy change of water, the final pressure in the tank, the amount of heat transfer between the tank and the surroundings, and the entropy generation during the process are to be determined.

Assumptions The tank is stationary and the kinetic and potential energy changes are negligible.

Analysis (a) Using saturated liquid properties for the compressed liquid at the initial state (Table A-4)

$$\left. \begin{array}{l} T_1 = 120^\circ\text{C} \\ x_1 = 0 \text{ (sat. liq.)} \end{array} \right\} \begin{array}{l} u_1 = 503.60 \text{ kJ/kg} \\ s_1 = 1.5279 \text{ kJ/kg}\cdot\text{K} \end{array}$$

The entropy change of water is zero, and thus at the final state we have

$$\left. \begin{array}{l} T_2 = 95^\circ\text{C} \\ s_2 = s_1 = 1.5279 \text{ kJ/kg}\cdot\text{K} \end{array} \right\} \begin{array}{l} P_2 = \mathbf{84.6 \text{ kPa}} \\ u_2 = 492.63 \text{ kJ/kg} \end{array}$$

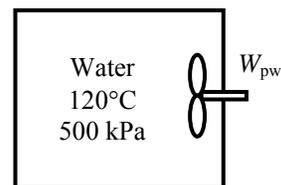

(b) The heat transfer can be determined from an energy balance on the tank

$$Q_{\text{out}} = W_{\text{pw,in}} - m(u_2 - u_1) = 22 \text{ kJ} - (1.5 \text{ kg})(492.63 - 503.60) \text{ kJ/kg} = \mathbf{38.5 \text{ kJ}}$$

(c) Since the entropy change of water is zero, the entropy generation is only due to the entropy increase of the surroundings, which is determined from

$$S_{\text{gen}} = \Delta S_{\text{surr}} = \frac{Q_{\text{out}}}{T_{\text{surr}}} = \frac{38.5 \text{ kJ}}{(15 + 273) \text{ K}} = \mathbf{0.134 \text{ kJ/K}}$$

7-193 A horizontal cylinder is separated into two compartments by a piston, one side containing nitrogen and the other side containing helium. Heat is added to the nitrogen side. The final temperature of the helium, the final volume of the nitrogen, the heat transferred to the nitrogen, and the entropy generation during this process are to be determined.

Assumptions **1** Kinetic and potential energy changes are negligible. **2** Nitrogen and helium are ideal gases with constant specific heats at room temperature. **3** The piston is adiabatic and frictionless.

Properties The properties of nitrogen at room temperature are $R = 0.2968 \text{ kPa}\cdot\text{m}^3/\text{kg}\cdot\text{K}$, $c_p = 1.039 \text{ kJ/kg}\cdot\text{K}$, $c_v = 0.743 \text{ kJ/kg}\cdot\text{K}$, $k = 1.4$. The properties for helium are $R = 2.0769 \text{ kPa}\cdot\text{m}^3/\text{kg}\cdot\text{K}$, $c_p = 5.1926 \text{ kJ/kg}\cdot\text{K}$, $c_v = 3.1156 \text{ kJ/kg}\cdot\text{K}$, $k = 1.667$ (Table A-2).

Analysis (a) Helium undergoes an isentropic compression process, and thus the final helium temperature is determined from

$$T_{\text{He},2} = T_1 \left(\frac{P_2}{P_1} \right)^{(k-1)/k} = (20 + 273)\text{K} \left(\frac{120 \text{ kPa}}{95 \text{ kPa}} \right)^{(1.667-1)/1.667} = \mathbf{321.7 \text{ K}}$$

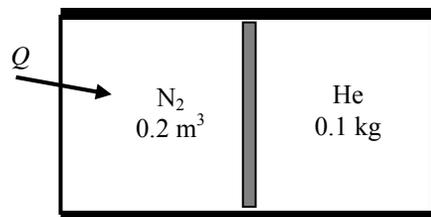

(b) The initial and final volumes of the helium are

$$V_{\text{He},1} = \frac{mRT_1}{P_1} = \frac{(0.1 \text{ kg})(2.0769 \text{ kPa}\cdot\text{m}^3/\text{kg}\cdot\text{K})(20 + 273 \text{ K})}{95 \text{ kPa}} = 0.6406 \text{ m}^3$$

$$V_{\text{He},2} = \frac{mRT_2}{P_2} = \frac{(0.1 \text{ kg})(2.0769 \text{ kPa}\cdot\text{m}^3/\text{kg}\cdot\text{K})(321.7 \text{ K})}{120 \text{ kPa}} = 0.5568 \text{ m}^3$$

Then, the final volume of nitrogen becomes

$$V_{\text{N}_2,2} = V_{\text{N}_2,1} + V_{\text{He},1} - V_{\text{He},2} = 0.2 + 0.6406 - 0.5568 = \mathbf{0.2838 \text{ m}^3}$$

(c) The mass and final temperature of nitrogen are

$$m_{\text{N}_2} = \frac{P_1 V_1}{RT_1} = \frac{(95 \text{ kPa})(0.2 \text{ m}^3)}{(0.2968 \text{ kPa}\cdot\text{m}^3/\text{kg}\cdot\text{K})(20 + 273 \text{ K})} = 0.2185 \text{ kg}$$

$$T_{\text{N}_2,2} = \frac{P_2 V_2}{mR} = \frac{(120 \text{ kPa})(0.2838 \text{ m}^3)}{(0.2185 \text{ kg})(0.2968 \text{ kPa}\cdot\text{m}^3/\text{kg}\cdot\text{K})} = 525.1 \text{ K}$$

The heat transferred to the nitrogen is determined from an energy balance

$$\begin{aligned} Q_{\text{in}} &= \Delta U_{\text{N}_2} + \Delta U_{\text{He}} \\ &= [mc_v(T_2 - T_1)]_{\text{N}_2} + [mc_v(T_2 - T_1)]_{\text{He}} \\ &= (0.2185 \text{ kg})(0.743 \text{ kJ/kg}\cdot\text{K})(525.1 - 293) + (0.1 \text{ kg})(3.1156 \text{ kJ/kg}\cdot\text{K})(321.7 - 293) \\ &= \mathbf{46.6 \text{ kJ}} \end{aligned}$$

(d) Noting that helium undergoes an isentropic process, the entropy generation is determined to be

$$\begin{aligned} S_{\text{gen}} &= \Delta S_{\text{N}_2} + \Delta S_{\text{surr}} = m_{\text{N}_2} \left(c_p \ln \frac{T_2}{T_1} - R \ln \frac{P_2}{P_1} \right) + \frac{-Q_{\text{in}}}{T_R} \\ &= (0.2185 \text{ kg}) \left[(1.039 \text{ kJ/kg}\cdot\text{K}) \ln \frac{525.1 \text{ K}}{293 \text{ K}} - (0.2968 \text{ kJ/kg}\cdot\text{K}) \ln \frac{120 \text{ kPa}}{95 \text{ kPa}} \right] + \frac{-46.6 \text{ kJ}}{(500 + 273) \text{ K}} \\ &= \mathbf{0.057 \text{ kJ/K}} \end{aligned}$$

7-194 An electric resistance heater is doing work on carbon dioxide contained in a rigid tank. The final temperature in the tank, the amount of heat transfer, and the entropy generation are to be determined.

Assumptions 1 Kinetic and potential energy changes are negligible. **2** Carbon dioxide is ideal gas with constant specific heats at room temperature.

Properties The properties of CO₂ at an anticipated average temperature of 350 K are $R = 0.1889$ kPa·m³/kg·K, $c_p = 0.895$ kJ/kg·K, $c_v = 0.706$ kJ/kg·K (Table A-2b).

Analysis (a) The mass and the final temperature of CO₂ may be determined from ideal gas equation

$$m = \frac{P_1 \mathcal{V}}{RT_1} = \frac{(100 \text{ kPa})(0.8 \text{ m}^3)}{(0.1889 \text{ kPa} \cdot \text{m}^3/\text{kg} \cdot \text{K})(250 \text{ K})} = 1.694 \text{ kg}$$

$$T_2 = \frac{P_2 \mathcal{V}}{mR} = \frac{(175 \text{ kPa})(0.8 \text{ m}^3)}{(1.694 \text{ kg})(0.1889 \text{ kPa} \cdot \text{m}^3/\text{kg} \cdot \text{K})} = \mathbf{437.5 \text{ K}}$$

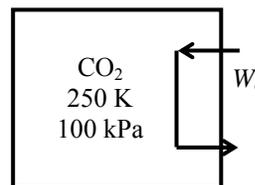

(b) The amount of heat transfer may be determined from an energy balance on the system

$$\begin{aligned} Q_{\text{out}} &= \dot{E}_{e,\text{in}} \Delta t - mc_v(T_2 - T_1) \\ &= (0.5 \text{ kW})(40 \times 60 \text{ s}) - (1.694 \text{ kg})(0.706 \text{ kJ/kg} \cdot \text{K})(437.5 - 250) \text{ K} = \mathbf{975.8 \text{ kJ}} \end{aligned}$$

(c) The entropy generation associated with this process may be obtained by calculating total entropy change, which is the sum of the entropy changes of CO₂ and the surroundings

$$\begin{aligned} S_{\text{gen}} &= \Delta S_{\text{CO}_2} + \Delta S_{\text{surr}} = m \left(c_p \ln \frac{T_2}{T_1} - R \ln \frac{P_2}{P_1} \right) + \frac{Q_{\text{out}}}{T_{\text{surr}}} \\ &= (1.694 \text{ kg}) \left[(0.895 \text{ kJ/kg} \cdot \text{K}) \ln \frac{437.5 \text{ K}}{250 \text{ K}} - (0.1889 \text{ kJ/kg} \cdot \text{K}) \ln \frac{175 \text{ kPa}}{100 \text{ kPa}} \right] + \frac{975.8 \text{ kJ}}{300 \text{ K}} \\ &= \mathbf{3.92 \text{ kJ/K}} \end{aligned}$$

7-195 Heat is lost from the helium as it is throttled in a throttling valve. The exit pressure and temperature of helium and the entropy generation are to be determined.

Assumptions **1** Steady operating conditions exist. **2** Kinetic and potential energy changes are negligible. **3** Helium is an ideal gas with constant specific heats.

Properties The properties of helium are $R = 2.0769$ kPa·m³/kg·K, $c_p = 5.1926$ kJ/kg·K (Table A-2a).

Analysis (a) The final temperature of helium may be determined from an energy balance on the control volume

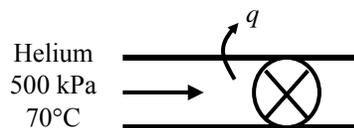

$$q_{\text{out}} = c_p (T_1 - T_2) \longrightarrow T_2 = T_1 - \frac{q_{\text{out}}}{c_p} = 70^\circ\text{C} - \frac{2.5 \text{ kJ/kg}}{5.1926 \text{ kJ/kg}\cdot^\circ\text{C}} = 342.5 \text{ K} = \mathbf{69.5^\circ\text{C}}$$

The final pressure may be determined from the relation for the entropy change of helium

$$\Delta s_{\text{He}} = c_p \ln \frac{T_2}{T_1} - R \ln \frac{P_2}{P_1}$$

$$0.25 \text{ kJ/kg}\cdot\text{K} = (5.1926 \text{ kJ/kg}\cdot\text{K}) \ln \frac{342.5 \text{ K}}{343 \text{ K}} - (2.0769 \text{ kJ/kg}\cdot\text{K}) \ln \frac{P_2}{500 \text{ kPa}}$$

$$P_2 = \mathbf{441.7 \text{ kPa}}$$

(b) The entropy generation associated with this process may be obtained by adding the entropy change of helium as it flows in the valve and the entropy change of the surroundings

$$s_{\text{gen}} = \Delta s_{\text{He}} + \Delta s_{\text{surr}} = \Delta s_{\text{He}} + \frac{q_{\text{out}}}{T_{\text{surr}}} = 0.25 \text{ kJ/kg}\cdot\text{K} + \frac{2.5 \text{ kJ/kg}}{(25 + 273) \text{ K}} = \mathbf{0.258 \text{ kJ/kg}\cdot\text{K}}$$

7-196 Refrigerant-134a is compressed in a compressor. The rate of heat loss from the compressor, the exit temperature of R-134a, and the rate of entropy generation are to be determined.

Assumptions 1 Steady operating conditions exist. **2** Kinetic and potential energy changes are negligible.

Analysis (a) The properties of R-134a at the inlet of the compressor are (Table A-12)

$$P_1 = 200 \text{ kPa} \left. \begin{array}{l} \nu_1 = 0.09987 \text{ m}^3/\text{kg} \\ h_1 = 244.46 \text{ kJ/kg} \\ s_1 = 0.93773 \text{ kJ/kg}\cdot\text{K} \end{array} \right\} x_1 = 1$$

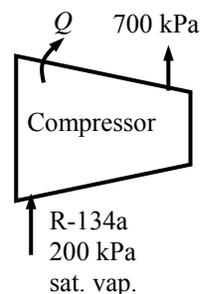

The mass flow rate of the refrigerant is

$$\dot{m} = \frac{\dot{V}_1}{\nu_1} = \frac{0.03 \text{ m}^3/\text{s}}{0.09987 \text{ m}^3/\text{kg}} = 0.3004 \text{ kg/s}$$

Given the entropy increase of the surroundings, the heat lost from the compressor is

$$\Delta \dot{S}_{\text{surr}} = \frac{\dot{Q}_{\text{out}}}{T_{\text{surr}}} \longrightarrow \dot{Q}_{\text{out}} = T_{\text{surr}} \Delta \dot{S}_{\text{surr}} = (20 + 273 \text{ K})(0.008 \text{ kW/K}) = \mathbf{2.344 \text{ kW}}$$

(b) An energy balance on the compressor gives

$$\begin{aligned} \dot{W}_{\text{in}} - \dot{Q}_{\text{out}} &= \dot{m}(h_2 - h_1) \\ 10 \text{ kW} - 2.344 \text{ kW} &= (0.3004 \text{ kg/s})(h_2 - 244.46) \text{ kJ/kg} \longrightarrow h_2 = 269.94 \text{ kJ/kg} \end{aligned}$$

The exit state is now fixed. Then,

$$\left. \begin{array}{l} P_2 = 700 \text{ kPa} \\ h_2 = 269.94 \text{ kJ/kg} \end{array} \right\} \begin{array}{l} T_2 = \mathbf{31.5^\circ\text{C}} \\ s_2 = 0.93620 \text{ kJ/kg}\cdot\text{K} \end{array}$$

(c) The entropy generation associated with this process may be obtained by adding the entropy change of R-134a as it flows in the compressor and the entropy change of the surroundings

$$\begin{aligned} \dot{S}_{\text{gen}} &= \Delta \dot{S}_{\text{R}} + \Delta \dot{S}_{\text{surr}} = \dot{m}(s_2 - s_1) + \Delta \dot{S}_{\text{surr}} \\ &= (0.3004 \text{ kg/s})(0.93620 - 0.93773) \text{ kJ/kg}\cdot\text{K} + 0.008 \text{ kW/K} \\ &= \mathbf{0.00754 \text{ kJ/K}} \end{aligned}$$

7-197 Air flows in an adiabatic nozzle. The isentropic efficiency, the exit velocity, and the entropy generation are to be determined.

Properties The gas constant of air is $R = 0.287 \text{ kJ/kg}\cdot\text{K}$ (Table A-1).

Assumptions 1 Steady operating conditions exist. 2 Potential energy changes are negligible.

Analysis (a) (b) Using variable specific heats, the properties can be determined from air table as follows

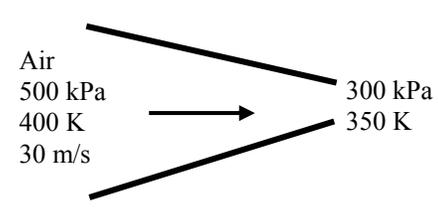
$$\begin{aligned}
 T_1 = 400 \text{ K} &\longrightarrow h_1 = 400.98 \text{ kJ/kg} \\
 &\quad s_1^0 = 1.99194 \text{ kJ/kg}\cdot\text{K} \\
 &\quad P_{r1} = 3.806 \\
 T_2 = 350 \text{ K} &\longrightarrow h_2 = 350.49 \text{ kJ/kg} \\
 &\quad s_2^0 = 1.85708 \text{ kJ/kg}\cdot\text{K} \\
 P_{r2} = \frac{P_2}{P_1} P_{r1} = \frac{300 \text{ kPa}}{500 \text{ kPa}} (3.806) = 2.2836 &\longrightarrow h_{2s} = 346.31 \text{ kJ/kg}
 \end{aligned}$$

Energy balances on the control volume for the actual and isentropic processes give

$$\begin{aligned}
 h_1 + \frac{V_1^2}{2} &= h_2 + \frac{V_2^2}{2} \\
 400.98 \text{ kJ/kg} + \frac{(30 \text{ m/s})^2}{2} \left(\frac{1 \text{ kJ/kg}}{1000 \text{ m}^2/\text{s}^2} \right) &= 350.49 \text{ kJ/kg} + \frac{V_2^2}{2} \left(\frac{1 \text{ kJ/kg}}{1000 \text{ m}^2/\text{s}^2} \right) \\
 V_2 &= \mathbf{319.1 \text{ m/s}}
 \end{aligned}$$

$$\begin{aligned}
 h_1 + \frac{V_1^2}{2} &= h_{2s} + \frac{V_{2s}^2}{2} \\
 400.98 \text{ kJ/kg} + \frac{(30 \text{ m/s})^2}{2} \left(\frac{1 \text{ kJ/kg}}{1000 \text{ m}^2/\text{s}^2} \right) &= 346.31 \text{ kJ/kg} + \frac{V_{2s}^2}{2} \left(\frac{1 \text{ kJ/kg}}{1000 \text{ m}^2/\text{s}^2} \right) \\
 V_{2s} &= 331.8 \text{ m/s}
 \end{aligned}$$

The isentropic efficiency is determined from its definition,

$$\eta_N = \frac{V_2^2}{V_{2s}^2} = \frac{(319.1 \text{ m/s})^2}{(331.8 \text{ m/s})^2} = \mathbf{0.925}$$

(c) Since the nozzle is adiabatic, the entropy generation is equal to the entropy increase of the air as it flows in the nozzle

$$\begin{aligned}
 s_{\text{gen}} &= \Delta s_{\text{air}} = s_2^0 - s_1^0 - R \ln \frac{P_2}{P_1} \\
 &= (1.85708 - 1.99194) \text{ kJ/kg}\cdot\text{K} - (0.287 \text{ kJ/kg}\cdot\text{K}) \ln \frac{300 \text{ kPa}}{500 \text{ kPa}} = \mathbf{0.0118 \text{ kJ/kg}\cdot\text{K}}
 \end{aligned}$$

7-198 It is to be shown that the difference between the steady-flow and boundary works is the flow energy.

Analysis The total differential of flow energy Pv can be expressed as

$$d(Pv) = Pd v + v dP = \delta w_b - \delta w_{flow} = \delta(w_b - w_{flow})$$

Therefore, the difference between the reversible steady-flow work and the reversible boundary work is the flow energy.

7-199 An insulated rigid tank is connected to a piston-cylinder device with zero clearance that is maintained at constant pressure. A valve is opened, and some steam in the tank is allowed to flow into the cylinder. The final temperatures in the tank and the cylinder are to be determined.

Assumptions 1 Both the tank and cylinder are well-insulated and thus heat transfer is negligible. **2** The water that remains in the tank underwent a reversible adiabatic process. **3** The thermal energy stored in the tank and cylinder themselves is negligible. **4** The system is stationary and thus kinetic and potential energy changes are negligible.

Analysis (a) The steam in tank A undergoes a reversible, adiabatic process, and thus $s_2 = s_1$. From the steam tables (Tables A-4 through A-6),

$$\begin{aligned}
 P_1 = 500 \text{ kPa} \left. \begin{array}{l} \nu_1 = \nu_{g@500 \text{ kPa}} = 0.37483 \text{ m}^3/\text{kg} \\ u_1 = u_{g@500 \text{ kPa}} = 2560.7 \text{ kJ/kg} \\ s_1 = s_{g@500 \text{ kPa}} = 6.8207 \text{ kJ/kg} \cdot \text{K} \end{array} \right\} \text{sat. vapor} \\
 P_2 = 150 \text{ kPa} \left. \begin{array}{l} T_{2,A} = T_{\text{sat}@150 \text{ kPa}} = \mathbf{111.35^\circ\text{C}} \\ s_{2,A} = s_1 \\ \nu_{2,A} = \nu_f + x_{2,A} \nu_{fg} = 0.001053 + (0.9305)(1.1594 - 0.001053) = 1.0789 \text{ m}^3/\text{kg} \\ u_{2,A} = u_f + x_{2,A} u_{fg} = 466.97 + (0.9305)(2052.3 \text{ kJ/kg}) = 2376.6 \text{ kJ/kg} \end{array} \right\} \text{(sat. mixture)} \\
 x_{2,A} = \frac{s_{2,A} - s_f}{s_{fg}} = \frac{6.8207 - 1.4337}{5.7894} = 0.9305
 \end{aligned}$$

The initial and the final masses in tank A are

$$m_{1,A} = \frac{\nu_A}{\nu_{1,A}} = \frac{0.4 \text{ m}^3}{0.37483 \text{ m}^3/\text{kg}} = 1.067 \text{ kg} \quad \text{and} \quad m_{2,A} = \frac{\nu_A}{\nu_{2,A}} = \frac{0.4 \text{ m}^3}{1.0789 \text{ m}^3/\text{kg}} = 0.371 \text{ kg}$$

Thus,

$$m_{2,B} = m_{1,A} - m_{2,A} = 1.067 - 0.371 = 0.696 \text{ kg}$$

(b) The boundary work done during this process is

$$W_{b,\text{out}} = \int_1^2 P dV = P_B (\nu_{2,B} - 0) = P_B m_{2,B} \nu_{2,B}$$

Taking the contents of both the tank and the cylinder to be the system, the energy balance for this closed system can be expressed as

$$\underbrace{E_{\text{in}} - E_{\text{out}}}_{\text{Net energy transfer by heat, work, and mass}} = \underbrace{\Delta E_{\text{system}}}_{\text{Change in internal, kinetic, potential, etc. energies}} \\
 -W_{b,\text{out}} = \Delta U = (\Delta U)_A + (\Delta U)_B$$

$$\begin{aligned}
 W_{b,\text{out}} + (\Delta U)_A + (\Delta U)_B &= 0 \\
 \text{or, } P_B m_{2,B} \nu_{2,B} + (m_2 u_2 - m_1 u_1)_A + (m_2 u_2)_B &= 0 \\
 m_{2,B} h_{2,B} + (m_2 u_2 - m_1 u_1)_A &= 0
 \end{aligned}$$

Thus,

$$h_{2,B} = \frac{(m_1 u_1 - m_2 u_2)_A}{m_{2,B}} = \frac{(1.067)(2560.7) - (0.371)(2376.6)}{0.696} = 2658.8 \text{ kJ/kg}$$

At 150 kPa, $h_f = 467.13$ and $h_g = 2693.1$ kJ/kg. Thus at the final state, the cylinder will contain a saturated liquid-vapor mixture since $h_f < h_2 < h_g$. Therefore,

$$T_{2,B} = T_{\text{sat}@150 \text{ kPa}} = \mathbf{111.35^\circ\text{C}}$$

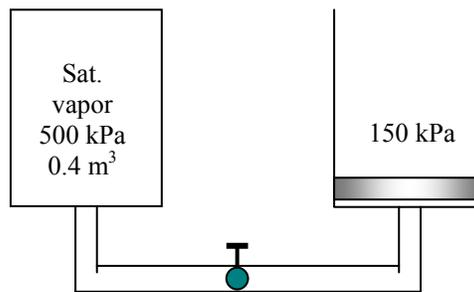

7-200 Carbon dioxide is compressed in a reversible isothermal process using a steady-flow device. The work required and the heat transfer are to be determined.

Assumptions 1 Steady operating conditions exist. 2 Changes in the kinetic and potential energies are negligible. 3 CO₂ is an ideal gas with constant specific heats.

Properties The gas constant of CO₂ is $R = 0.1889 \text{ kPa}\cdot\text{m}^3/\text{kg}\cdot\text{K}$ (Table A-2a).

Analysis There is only one inlet and one exit, and thus $\dot{m}_1 = \dot{m}_2 = \dot{m}$. We take the compressor as the system, which is a control volume since mass crosses the boundary. The energy balance for this steady-flow system can be expressed in the rate form as

$$\underbrace{\dot{E}_{\text{in}} - \dot{E}_{\text{out}}}_{\text{Rate of net energy transfer by heat, work, and mass}} = \underbrace{\dot{\Delta E}_{\text{system}}}_{\text{Rate of change in internal, kinetic, potential, etc. energies}} \stackrel{\text{no (steady)}}{=} 0$$

$$\dot{E}_{\text{in}} = \dot{E}_{\text{out}}$$

$$\dot{m}h_1 + \dot{W}_{\text{in}} - \dot{Q}_{\text{out}} = \dot{m}h_2$$

$$\dot{W}_{\text{in}} - \dot{Q}_{\text{out}} = \dot{m}(h_2 - h_1) = \dot{m}c_p(T_2 - T_1)$$

$$\dot{W}_{\text{in}} = \dot{Q}_{\text{out}} \quad (\text{since } T_2 = T_1)$$

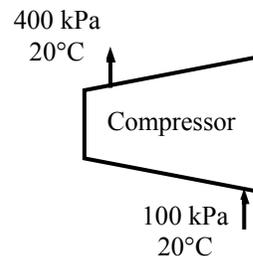

The work input for this isothermal, reversible process is

$$w_{\text{in}} = RT \ln \frac{P_2}{P_1} = (0.1889 \text{ kJ/kg}\cdot\text{K})(293 \text{ K}) \ln \frac{400 \text{ kPa}}{100 \text{ kPa}} = \mathbf{76.7 \text{ kJ/kg}}$$

From the energy balance equation,

$$q_{\text{out}} = w_{\text{in}} = \mathbf{76.7 \text{ kJ/kg}}$$

7-201 Carbon dioxide is compressed in an isentropic process using a steady-flow device. The work required and the heat transfer are to be determined.

Assumptions 1 Steady operating conditions exist. 2 Changes in the kinetic and potential energies are negligible. 3 CO₂ is an ideal gas with constant specific heats.

Properties The gas constant of CO₂ is $R = 0.1889 \text{ kPa}\cdot\text{m}^3/\text{kg}\cdot\text{K}$. Other properties at room temperature are $c_p = 0.846 \text{ kJ/kg}\cdot\text{K}$ and $k = 1.289$ (Table A-2a).

Analysis There is only one inlet and one exit, and thus $\dot{m}_1 = \dot{m}_2 = \dot{m}$. We take the compressor as the system, which is a control volume since mass crosses the boundary. The energy balance for this steady-flow system can be expressed in the rate form as

$$\underbrace{\dot{E}_{\text{in}} - \dot{E}_{\text{out}}}_{\text{Rate of net energy transfer by heat, work, and mass}} = \underbrace{\Delta \dot{E}_{\text{system}}}_{\text{Rate of change in internal, kinetic, potential, etc. energies}} \stackrel{\approx 0 \text{ (steady)}}{=} 0$$

$$\dot{E}_{\text{in}} = \dot{E}_{\text{out}}$$

$$\dot{m}h_1 + \dot{W}_{\text{in}} = \dot{m}h_2$$

$$\dot{W}_{\text{in}} = \dot{m}(h_2 - h_1) = \dot{m}c_p(T_2 - T_1)$$

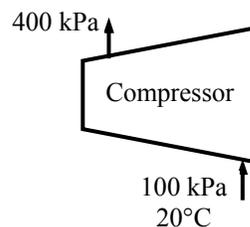

The temperature at the compressor exit for the isentropic process of an ideal gas is

$$T_2 = T_1 \left(\frac{P_2}{P_1} \right)^{(k-1)/k} = (293 \text{ K}) \left(\frac{400 \text{ kPa}}{100 \text{ kPa}} \right)^{0.289/1.289} = 399.8 \text{ K}$$

Substituting,

$$w_{\text{in}} = c_p(T_2 - T_1) = (0.846 \text{ kJ/kg}\cdot\text{K})(399.8 - 293)\text{K} = \mathbf{90.4 \text{ kJ}}$$

The work input increases from 76.7 kJ/kg to 90.4 kJ/kg when the process is executed isentropically instead of isothermally. Since the process is isentropic (i.e., reversible, adiabatic), the heat transfer is zero.

7-202 R-134a is compressed in an isentropic compressor. The work required is to be determined.

Assumptions 1 This is a steady-flow process since there is no change with time. **2** The process is isentropic (i.e., reversible-adiabatic). **3** Kinetic and potential energy changes are negligible.

Analysis There is only one inlet and one exit, and thus $\dot{m}_1 = \dot{m}_2 = \dot{m}$. We take the compressor as the system, which is a control volume since mass crosses the boundary. The energy balance for this steady-flow system can be expressed in the rate form as

$$\underbrace{\dot{E}_{\text{in}} - \dot{E}_{\text{out}}}_{\text{Rate of net energy transfer by heat, work, and mass}} = \underbrace{\dot{\Delta E}_{\text{system}}}_{\text{Rate of change in internal, kinetic, potential, etc. energies}} \stackrel{\text{no (steady)}}{=} 0$$

$$\dot{E}_{\text{in}} = \dot{E}_{\text{out}}$$

$$\dot{m}h_1 + \dot{W}_{\text{in}} = \dot{m}h_2$$

$$\dot{W}_{\text{in}} = \dot{m}(h_2 - h_1)$$

The inlet state properties are

$$\left. \begin{array}{l} T_1 = -10^\circ\text{C} \\ x_1 = 1 \end{array} \right\} \begin{array}{l} h_1 = 244.51 \text{ kJ/kg} \\ s_1 = 0.93766 \text{ kJ/kg}\cdot\text{K} \end{array} \quad (\text{Table A-11})$$

For this isentropic process, the final state enthalpy is

$$\left. \begin{array}{l} P_2 = 800 \text{ kPa} \\ s_2 = s_1 = 0.93766 \text{ kJ/kg}\cdot\text{K} \end{array} \right\} h_2 = 273.22 \text{ kJ/kg} \quad (\text{Table A-13})$$

Substituting,

$$w_{\text{in}} = h_2 - h_1 = (273.22 - 244.51) \text{ kJ/kg} = \mathbf{28.7 \text{ kJ/kg}}$$

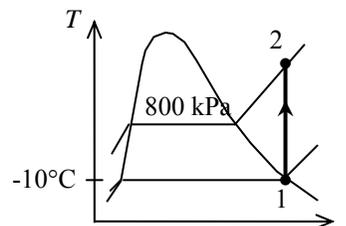
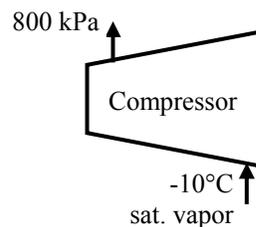

7-203 Refrigerant-134a is expanded adiabatically in a capillary tube. The rate of entropy generation is to be determined.

Assumptions 1 Steady operating conditions exist. 2 Kinetic and potential energy changes are negligible.

Analysis The rate of entropy generation within the expansion device during this process can be determined by applying the rate form of the entropy balance on the system. Noting that the system is adiabatic and thus there is no heat transfer, the entropy balance for this steady-flow system can be expressed as

$$\underbrace{\dot{S}_{\text{in}} - \dot{S}_{\text{out}}}_{\text{Rate of net entropy transfer by heat and mass}} + \underbrace{\dot{S}_{\text{gen}}}_{\text{Rate of entropy generation}} = \underbrace{\Delta \dot{S}_{\text{system}}}_{\text{Rate of change of entropy}} \overset{\neq 0 \text{ (steady)}}{=} 0$$

$$\dot{m}_1 s_1 - \dot{m}_2 s_2 + \dot{S}_{\text{gen}} = 0$$

$$\dot{S}_{\text{gen}} = \dot{m}(s_2 - s_1)$$

$$s_{\text{gen}} = s_2 - s_1$$

R-134a

Capillary tube
 →

-12°C

50°C
 sat. liq.

It may be easily shown with an energy balance that the enthalpy remains constant during the throttling process. The properties of the refrigerant at the inlet and exit states are (Tables A-11 through A-13)

$$\left. \begin{array}{l} T_1 = 50^\circ\text{C} \\ x_1 = 0 \end{array} \right\} \begin{array}{l} h_1 = 123.50 \text{ kJ/kg} \cdot \text{K} \\ s_1 = 0.44193 \text{ kJ/kg} \cdot \text{K} \end{array}$$

$$\left. \begin{array}{l} T_2 = -12^\circ\text{C} \\ h_2 = h_1 = 123.50 \text{ kJ/kg} \cdot \text{K} \end{array} \right\} \begin{array}{l} x_2 = \frac{h_2 - h_f}{h_{fg}} = \frac{123.50 - 35.92}{207.38} = 0.4223 \\ s_2 = s_f + x_2 s_{fg} = 0.14504 + (0.4223)(0.79406) = 0.48038 \text{ kJ/kg} \cdot \text{K} \end{array}$$

Substituting,

$$\dot{S}_{\text{gen}} = \dot{m}(s_2 - s_1) = (0.2 \text{ kg/s})(0.48038 - 0.44193) \text{ kJ/kg} \cdot \text{K} = \mathbf{0.00769 \text{ kW/K}}$$

7-204 Steam is expanded in an adiabatic turbine. Six percent of the inlet steam is bled for feedwater heating. The isentropic efficiencies for two stages of the turbine are given. The power produced by the turbine and the overall efficiency of the turbine are to be determined.

Assumptions 1 This is a steady-flow process since there is no change with time. **2** The turbine is well-insulated, and there is no heat transfer from the turbine.

Analysis There is one inlet and two exits. We take the turbine as the system, which is a control volume since mass crosses the boundary. The energy balance for this steady-flow system can be expressed in the rate form as

$$\underbrace{\dot{E}_{\text{in}} - \dot{E}_{\text{out}}}_{\text{Rate of net energy transfer by heat, work, and mass}} = \underbrace{\Delta \dot{E}_{\text{system}}}_{\text{Rate of change in internal, kinetic, potential, etc. energies}} \stackrel{\approx 0 \text{ (steady)}}{=} 0$$

$$\dot{E}_{\text{in}} = \dot{E}_{\text{out}}$$

$$\dot{m}_1 h_1 = \dot{m}_2 h_2 + \dot{m}_3 h_3 + \dot{W}_{\text{out}}$$

$$\dot{W}_{\text{out}} = \dot{m}_1 h_1 - \dot{m}_2 h_2 - \dot{m}_3 h_3$$

$$w_{\text{out}} = h_1 - 0.06h_2 - 0.94h_3$$

$$w_{\text{out}} = (h_1 - h_2) + 0.94(h_2 - h_3)$$

The isentropic and actual enthalpies at three states are determined using steam tables as follows:

$$\left. \begin{array}{l} P_1 = 4 \text{ MPa} \\ T_1 = 350^\circ\text{C} \end{array} \right\} \begin{array}{l} h_1 = 3093.3 \text{ kJ/kg} \\ s_1 = 6.5843 \text{ kJ/kg} \cdot \text{K} \end{array}$$

$$\left. \begin{array}{l} P_2 = 800 \text{ kPa} \\ s_2 = s_1 = 6.5843 \text{ kJ/kg} \cdot \text{K} \end{array} \right\} \begin{array}{l} x_{2s} = 0.9832 \\ h_{2s} = 2734.0 \text{ kJ/kg} \end{array}$$

$$\eta_{T,1} = \frac{h_1 - h_2}{h_1 - h_{2s}} \longrightarrow h_2 = h_1 - \eta_{T,1}(h_1 - h_{2s}) = 3093.3 - (0.97)(3093.3 - 2734.0) = 2744.8 \text{ kJ/kg}$$

$$\left. \begin{array}{l} P_2 = 800 \text{ kPa} \\ h_2 = 2744.8 \text{ kJ/kg} \end{array} \right\} \begin{array}{l} x_2 = 0.9885 \\ s_2 = 6.6086 \text{ kJ/kg} \cdot \text{K} \end{array}$$

$$\left. \begin{array}{l} P_3 = 30 \text{ kPa} \\ s_3 = s_2 = 6.6086 \text{ kJ/kg} \cdot \text{K} \end{array} \right\} \begin{array}{l} x_{3s} = 0.8302 \\ h_{3s} = 2227.9 \text{ kJ/kg} \end{array}$$

$$\eta_{T,2} = \frac{h_2 - h_3}{h_2 - h_{3s}} \longrightarrow h_3 = h_2 - \eta_{T,2}(h_2 - h_{3s}) = 2744.8 - (0.95)(2744.8 - 2227.9) = 2253.7 \text{ kJ/kg}$$

Substituting,

$$\begin{aligned} w_{\text{out}} &= (h_1 - h_2) + 0.94(h_2 - h_3) \\ &= (3093.3 - 2744.8) + 0.94(2744.8 - 2253.7) \\ &= \mathbf{810.1 \text{ kJ/kg - inlet}} \end{aligned}$$

The overall isentropic efficiency of the turbine is

$$\eta_T = \frac{(h_1 - h_2) + 0.94(h_2 - h_3)}{(h_1 - h_{2s}) + 0.94(h_2 - h_{3s})} = \frac{(3093.3 - 2744.8) + 0.94(2744.8 - 2253.7)}{(3093.3 - 2734.0) + 0.94(2744.8 - 2227.9)} = \frac{810.1}{845.2} = \mathbf{0.958 = 95.8\%}$$

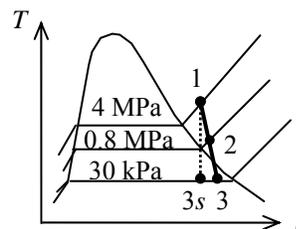
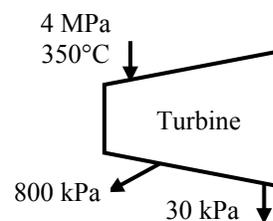

7-205 Air is compressed steadily by a compressor from a specified state to a specified pressure. The minimum power input required is to be determined for the cases of adiabatic and isothermal operation.

Assumptions 1 This is a steady-flow process since there is no change with time. **2** Kinetic and potential energy changes are negligible. **3** Air is an ideal gas with variable specific heats. **4** The process is reversible since the work input to the compressor will be minimum when the compression process is reversible.

Properties The gas constant of air is $R = 0.287 \text{ kJ/kg}\cdot\text{K}$ (Table A-1).

Analysis (a) For the adiabatic case, the process will be reversible and adiabatic (i.e., isentropic), thus the isentropic relations are applicable.

$$T_1 = 290 \text{ K} \longrightarrow P_{r_1} = 1.2311 \text{ and } h_1 = 290.16 \text{ kJ/kg}$$

and

$$P_2 = \frac{P_2}{P_1} P_1 = \frac{700 \text{ kPa}}{100 \text{ kPa}} (1.2311) = 8.6177 \rightarrow T_2 = 503.3 \text{ K} \\ h_2 = 506.45 \text{ kJ/kg}$$

The energy balance for the compressor, which is a steady-flow system, can be expressed in the rate form as

$$\underbrace{\dot{E}_{\text{in}} - \dot{E}_{\text{out}}}_{\text{Rate of net energy transfer by heat, work, and mass}} = \underbrace{\Delta \dot{E}_{\text{system}}^{\phi_0}}_{\text{Rate of change in internal, kinetic, potential, etc. energies (steady)}} = 0 \\ \dot{E}_{\text{in}} = \dot{E}_{\text{out}} \\ \dot{W}_{\text{in}} + \dot{m}h_1 = \dot{m}h_2 \rightarrow \dot{W}_{\text{in}} = \dot{m}(h_2 - h_1)$$

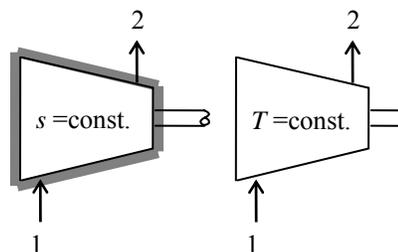

Substituting, the power input to the compressor is determined to be

$$\dot{W}_{\text{in}} = (5/60 \text{ kg/s})(506.45 - 290.16) \text{ kJ/kg} = \mathbf{18.0 \text{ kW}}$$

(b) In the case of the reversible isothermal process, the steady-flow energy balance becomes

$$\dot{E}_{\text{in}} = \dot{E}_{\text{out}} \rightarrow \dot{W}_{\text{in}} + \dot{m}h_1 - \dot{Q}_{\text{out}} = \dot{m}h_2 \rightarrow \dot{W}_{\text{in}} = \dot{Q}_{\text{out}} + \dot{m}(h_2 - h_1)^{\phi_0} = \dot{Q}_{\text{out}}$$

since $h = h(T)$ for ideal gases, and thus the enthalpy change in this case is zero. Also, for a reversible isothermal process,

$$\dot{Q}_{\text{out}} = \dot{m}T(s_1 - s_2) = -\dot{m}T(s_2 - s_1)$$

where

$$s_2 - s_1 = (s_2^\circ - s_1^\circ)^{\phi_0} - R \ln \frac{P_2}{P_1} = -R \ln \frac{P_2}{P_1} = -(0.287 \text{ kJ/kg}\cdot\text{K}) \ln \frac{700 \text{ kPa}}{100 \text{ kPa}} = -0.5585 \text{ kJ/kg}\cdot\text{K}$$

Substituting, the power input for the reversible isothermal case becomes

$$\dot{W}_{\text{in}} = -(5/60 \text{ kg/s})(290 \text{ K})(-0.5585 \text{ kJ/kg}\cdot\text{K}) = \mathbf{13.5 \text{ kW}}$$

7-206 Air is compressed in a two-stage ideal compressor with intercooling. For a specified mass flow rate of air, the power input to the compressor is to be determined, and it is to be compared to the power input to a single-stage compressor.

Assumptions 1 The compressor operates steadily. **2** Kinetic and potential energies are negligible. **3** The compression process is reversible adiabatic, and thus isentropic. **4** Air is an ideal gas with constant specific heats at room temperature.

Properties The gas constant of air is $R = 0.287 \text{ kPa}\cdot\text{m}^3/\text{kg}\cdot\text{K}$ (Table A-1). The specific heat ratio of air is $k = 1.4$ (Table A-2).

Analysis The intermediate pressure between the two stages is

$$P_x = \sqrt{P_1 P_2} = \sqrt{(100 \text{ kPa})(900 \text{ kPa})} = 300 \text{ kPa}$$

The compressor work across each stage is the same, thus total compressor work is twice the compression work for a single stage:

$$\begin{aligned} w_{\text{comp,in}} &= (2)(w_{\text{comp,in,I}}) = 2 \frac{kRT_1}{k-1} \left(\left(\frac{P_x}{P_1} \right)^{(k-1)/k} - 1 \right) \\ &= 2 \frac{(1.4)(0.287 \text{ kJ/kg}\cdot\text{K})(300 \text{ K})}{1.4-1} \left(\left(\frac{300 \text{ kPa}}{100 \text{ kPa}} \right)^{0.4/1.4} - 1 \right) \\ &= 222.2 \text{ kJ/kg} \end{aligned}$$

and

$$\dot{W}_{\text{in}} = \dot{m} w_{\text{comp,in}} = (0.02 \text{ kg/s})(222.2 \text{ kJ/kg}) = \mathbf{4.44 \text{ kW}}$$

The work input to a single-stage compressor operating between the same pressure limits would be

$$w_{\text{comp,in}} = \frac{kRT_1}{k-1} \left(\left(\frac{P_2}{P_1} \right)^{(k-1)/k} - 1 \right) = \frac{(1.4)(0.287 \text{ kJ/kg}\cdot\text{K})(300 \text{ K})}{1.4-1} \left(\left(\frac{900 \text{ kPa}}{100 \text{ kPa}} \right)^{0.4/1.4} - 1 \right) = 263.2 \text{ kJ/kg}$$

and

$$\dot{W}_{\text{in}} = \dot{m} w_{\text{comp,in}} = (0.02 \text{ kg/s})(263.2 \text{ kJ/kg}) = \mathbf{5.26 \text{ kW}}$$

Discussion Note that the power consumption of the compressor decreases significantly by using 2-stage compression with intercooling.

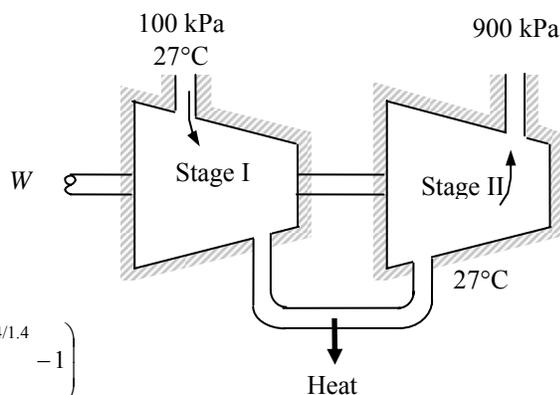

7-207 A three-stage compressor with two stages of intercooling is considered. The two intermediate pressures that will minimize the work input are to be determined in terms of the inlet and exit pressures.

Analysis The work input to this three-stage compressor with intermediate pressures P_x and P_y and two intercoolers can be expressed as

$$\begin{aligned} w_{\text{comp}} &= w_{\text{comp,I}} + w_{\text{comp,II}} + w_{\text{comp,III}} \\ &= \frac{nRT_1}{n-1} \left(1 - (P_x/P_1)^{(n-1)/n} \right) + \frac{nRT_1}{n-1} \left(1 - (P_y/P_x)^{(n-1)/n} \right) + \frac{nRT_1}{n-1} \left(1 - (P_x/P_1)^{(n-1)/n} \right) \\ &= \frac{nRT_1}{n-1} \left(1 - (P_x/P_1)^{(n-1)/n} + 1 - (P_y/P_x)^{(n-1)/n} + 1 - (P_x/P_1)^{(n-1)/n} \right) \\ &= \frac{nRT_1}{n-1} \left(3 - (P_x/P_1)^{(n-1)/n} - (P_y/P_x)^{(n-1)/n} - (P_x/P_1)^{(n-1)/n} \right) \end{aligned}$$

The P_x and P_y values that will minimize the work input are obtained by taking the partial differential of w with respect to P_x and P_y , and setting them equal to zero:

$$\begin{aligned} \frac{\partial w}{\partial P_x} = 0 &\longrightarrow -\frac{n-1}{n} \left(\frac{1}{P_1} \right) \left(\frac{P_x}{P_1} \right)^{\frac{n-1}{n}-1} + \frac{n-1}{n} \left(\frac{1}{P_y} \right) \left(\frac{P_x}{P_y} \right)^{\frac{n-1}{n}-1} = 0 \\ \frac{\partial w}{\partial P_y} = 0 &\longrightarrow -\frac{n-1}{n} \left(\frac{1}{P_x} \right) \left(\frac{P_y}{P_x} \right)^{\frac{n-1}{n}-1} + \frac{n-1}{n} \left(\frac{1}{P_2} \right) \left(\frac{P_y}{P_2} \right)^{\frac{n-1}{n}-1} = 0 \end{aligned}$$

Simplifying,

$$\begin{aligned} \frac{1}{P_1} \left(\frac{P_x}{P_1} \right)^{-\frac{1}{n}} &= \frac{1}{P_y} \left(\frac{P_x}{P_y} \right)^{-\frac{2n-1}{n}} \longrightarrow \frac{1}{P_1^n} \left(\frac{P_1}{P_x} \right) = \frac{1}{P_y^n} \left(\frac{P_x}{P_y} \right)^{1-2n} \longrightarrow P_x^{2(1-n)} = (P_1 P_y)^{1-n} \\ \frac{1}{P_x} \left(\frac{P_y}{P_x} \right)^{-\frac{1}{n}} &= \frac{1}{P_2} \left(\frac{P_y}{P_2} \right)^{-\frac{2n-1}{n}} \longrightarrow \frac{1}{P_x^n} \left(\frac{P_x}{P_y} \right) = \frac{1}{P_2^n} \left(\frac{P_y}{P_2} \right)^{1-2n} \longrightarrow P_y^{2(1-n)} = (P_x P_2)^{1-n} \end{aligned}$$

which yield

$$\begin{aligned} P_x^2 &= P_1 \sqrt{P_x P_2} \longrightarrow P_x = (P_1^2 P_2)^{1/3} \\ P_y^2 &= P_2 \sqrt{P_1 P_y} \longrightarrow P_y = (P_1 P_2^2)^{1/3} \end{aligned}$$

7-208 Steam expands in a two-stage adiabatic turbine from a specified state to specified pressure. Some steam is extracted at the end of the first stage. The power output of the turbine is to be determined for the cases of 100% and 88% isentropic efficiencies.

Assumptions 1 This is a steady-flow process since there is no change with time. **2** Kinetic and potential energy changes are negligible. **3** The turbine is adiabatic and thus heat transfer is negligible.

Properties From the steam tables (Tables A-4 through 6)

$$\left. \begin{array}{l} P_1 = 6 \text{ MPa} \\ T_1 = 500^\circ\text{C} \end{array} \right\} \begin{array}{l} h_1 = 3423.1 \text{ kJ/kg} \\ s_1 = 6.8826 \text{ kJ/kg} \cdot \text{K} \end{array}$$

$$\left. \begin{array}{l} P_2 = 1.2 \text{ MPa} \\ s_2 = s_1 \end{array} \right\} h_2 = 2962.8 \text{ kJ/kg}$$

$$\left. \begin{array}{l} P_3 = 20 \text{ kPa} \\ s_3 = s_1 \end{array} \right\} \begin{array}{l} x_{3s} = \frac{s_{3s} - s_f}{s_{fg}} = \frac{6.8826 - 0.8320}{7.0752} = 0.8552 \\ h_{3s} = h_f + x_{3s}h_{fg} = 251.42 + (0.8552)(2357.5) = 2267.5 \text{ kJ/kg} \end{array}$$

Analysis (a) The mass flow rate through the second stage is

$$\dot{m}_3 = 0.9\dot{m}_1 = (0.9)(15 \text{ kg/s}) = 13.5 \text{ kg/s}$$

We take the entire turbine, including the connection part between the two stages, as the system, which is a control volume since mass crosses the boundary. Noting that one fluid stream enters the turbine and two fluid streams leave, the energy balance for this steady-flow system can be expressed in the rate form as

$$\underbrace{\dot{E}_{\text{in}} - \dot{E}_{\text{out}}}_{\text{Rate of net energy transfer by heat, work, and mass}} = \underbrace{\Delta \dot{E}_{\text{system}}^{\neq 0} \text{ (steady)}}_{\text{Rate of change in internal, kinetic, potential, etc. energies}} = 0$$

$$\dot{E}_{\text{in}} = \dot{E}_{\text{out}}$$

$$\begin{aligned} \dot{m}_1 h_1 &= (\dot{m}_1 - \dot{m}_3) h_2 + \dot{W}_{\text{out}} + \dot{m}_3 h_3 \\ \dot{W}_{\text{out}} &= \dot{m}_1 h_1 - (\dot{m}_1 - \dot{m}_3) h_2 - \dot{m}_3 h_3 \\ &= \dot{m}_1 (h_1 - h_2) + \dot{m}_3 (h_2 - h_3) \end{aligned}$$

Substituting, the power output of the turbine is

$$\dot{W}_{\text{out}} = (15 \text{ kg/s})(3423.1 - 2962.8) \text{ kJ/kg} + (13.5 \text{ kg})(2962.8 - 2267.5) \text{ kJ/kg} = \mathbf{16,291 \text{ kW}}$$

(b) If the turbine has an adiabatic efficiency of 88%, then the power output becomes

$$\dot{W}_a = \eta_T \dot{W}_s = (0.88)(16,291 \text{ kW}) = \mathbf{14,336 \text{ kW}}$$

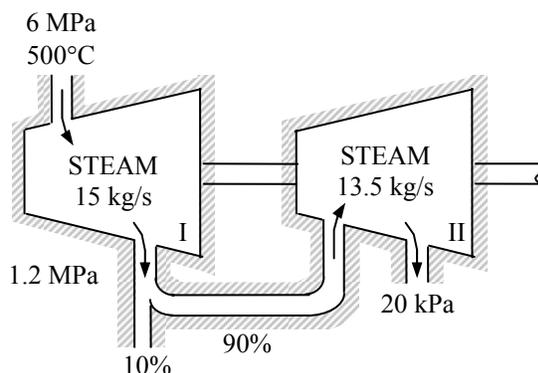

7-209 Steam expands in an 84% efficient two-stage adiabatic turbine from a specified state to a specified pressure. Steam is reheated between the stages. For a given power output, the mass flow rate of steam through the turbine is to be determined.

Assumptions **1** This is a steady-flow process since there is no change with time. **2** Kinetic and potential energy changes are negligible. **3** The turbine is adiabatic and thus heat transfer is negligible.

Properties From the steam tables (Tables A-4 through 6)

$$\left. \begin{array}{l} P_1 = 8 \text{ MPa} \\ T_1 = 550^\circ\text{C} \end{array} \right\} \begin{array}{l} h_1 = 3521.8 \text{ kJ/kg} \\ s_1 = 6.8800 \text{ kJ/kg} \cdot \text{K} \end{array}$$

$$\left. \begin{array}{l} P_{2s} = 2 \text{ MPa} \\ s_{2s} = s_1 \end{array} \right\} h_{2s} = 3089.7 \text{ kJ/kg}$$

$$\left. \begin{array}{l} P_3 = 2 \text{ MPa} \\ T_3 = 550^\circ\text{C} \end{array} \right\} \begin{array}{l} h_3 = 3579.0 \text{ kJ/kg} \\ s_3 = 7.5725 \text{ kJ/kg} \cdot \text{K} \end{array}$$

$$\left. \begin{array}{l} P_{4s} = 200 \text{ kPa} \\ s_{4s} = s_3 \end{array} \right\} h_{4s} = 2901.7 \text{ kJ/kg}$$

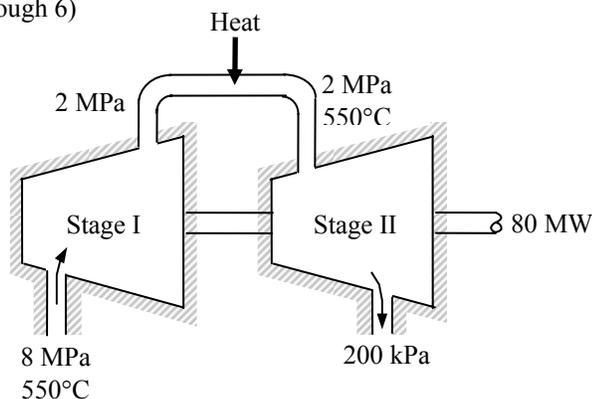

Analysis The power output of the actual turbine is given to be 80 MW. Then the power output for the isentropic operation becomes

$$\dot{W}_{s,\text{out}} = \dot{W}_{a,\text{out}} / \eta_T = (80,000 \text{ kW}) / 0.84 = 95,240 \text{ kW}$$

We take the entire turbine, excluding the reheat section, as the system, which is a control volume since mass crosses the boundary. The energy balance for this steady-flow system in isentropic operation can be expressed in the rate form as

$$\underbrace{\dot{E}_{\text{in}} - \dot{E}_{\text{out}}}_{\text{Rate of net energy transfer by heat, work, and mass}} = \underbrace{\Delta \dot{E}_{\text{system}}^{\neq 0} (\text{steady})}_{\text{Rate of change in internal, kinetic, potential, etc. energies}} = 0$$

$$\dot{E}_{\text{in}} = \dot{E}_{\text{out}}$$

$$\dot{m}h_1 + \dot{m}h_3 = \dot{m}h_{2s} + \dot{m}h_{4s} + \dot{W}_{s,\text{out}}$$

$$\dot{W}_{s,\text{out}} = \dot{m}[(h_1 - h_{2s}) + (h_3 - h_{4s})]$$

Substituting,

$$95,240 \text{ kJ/s} = \dot{m}[(3521.8 - 3089.7) \text{ kJ/kg} + (3579.0 - 2901.7) \text{ kJ/kg}]$$

which gives

$$\dot{m} = \mathbf{85.8 \text{ kg/s}}$$

7-210 Refrigerant-134a is compressed by a 0.7-kW adiabatic compressor from a specified state to another specified state. The isentropic efficiency, the volume flow rate at the inlet, and the maximum flow rate at the compressor inlet are to be determined.

Assumptions 1 This is a steady-flow process since there is no change with time. **2** Kinetic and potential energy changes are negligible. **3** The device is adiabatic and thus heat transfer is negligible.

Properties From the R-134a tables (Tables A-11 through A-13)

$$\left. \begin{array}{l} P_1 = 140 \text{ kPa} \\ T_1 = -10^\circ\text{C} \end{array} \right\} \begin{array}{l} v_1 = 0.14605 \text{ m}^3/\text{kg} \\ h_1 = 246.36 \text{ kJ/kg} \\ s_1 = 0.9724 \text{ kJ/kg}\cdot\text{K} \end{array}$$

$$\left. \begin{array}{l} P_2 = 700 \text{ kPa} \\ T_2 = 50^\circ\text{C} \end{array} \right\} h_2 = 288.53 \text{ kJ/kg}$$

$$\left. \begin{array}{l} P_2 = 700 \text{ kPa} \\ s_{2s} = s_1 \end{array} \right\} h_{2s} = 281.16 \text{ kJ/kg}$$

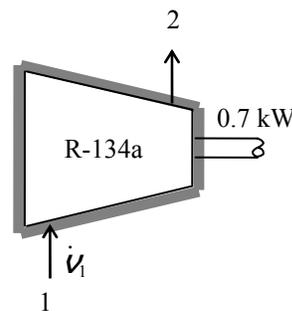

Analysis (a) The isentropic efficiency is determined from its definition,

$$\eta_C = \frac{h_{2s} - h_1}{h_{2a} - h_1} = \frac{281.16 - 246.36}{288.53 - 246.36} = 0.825 = \mathbf{82.5\%}$$

(b) There is only one inlet and one exit, and thus $\dot{m}_1 = \dot{m}_2 = \dot{m}$. We take the actual compressor as the system, which is a control volume. The energy balance for this steady-flow system can be expressed as

$$\underbrace{\dot{E}_{\text{in}} - \dot{E}_{\text{out}}}_{\text{Rate of net energy transfer by heat, work, and mass}} = \underbrace{\Delta \dot{E}_{\text{system}}^{\phi 0}}_{\text{Rate of change in internal, kinetic, potential, etc. energies (steady)}} = 0$$

$$\dot{E}_{\text{in}} = \dot{E}_{\text{out}}$$

$$\dot{W}_{\text{a,in}} + \dot{m}h_1 = \dot{m}h_2 \quad (\text{since } \dot{Q} \cong \Delta \text{ke} \cong \Delta \text{pe} \cong 0)$$

$$\dot{W}_{\text{a,in}} = \dot{m}(h_2 - h_1)$$

Then the mass and volume flow rates of the refrigerant are determined to be

$$\dot{m} = \frac{\dot{W}_{\text{a,in}}}{h_{2a} - h_1} = \frac{0.7 \text{ kJ/s}}{(288.53 - 246.36) \text{ kJ/kg}} = 0.0166 \text{ kg/s}$$

$$\dot{V}_1 = \dot{m}v_1 = (0.0166 \text{ kg/s})(0.14605 \text{ m}^3/\text{kg}) = 0.00242 \text{ m}^3/\text{s} = \mathbf{145 \text{ L/min}}$$

(c) The volume flow rate will be a maximum when the process is isentropic, and it is determined similarly from the steady-flow energy equation applied to the isentropic process. It gives

$$\dot{m}_{\text{max}} = \frac{\dot{W}_{\text{s,in}}}{h_{2s} - h_1} = \frac{0.7 \text{ kJ/s}}{(281.16 - 246.36) \text{ kJ/kg}} = 0.0201 \text{ kg/s}$$

$$\dot{V}_{1,\text{max}} = \dot{m}_{\text{max}}v_1 = (0.0201 \text{ kg/s})(0.14605 \text{ m}^3/\text{kg}) = 0.00294 \text{ m}^3/\text{s} = \mathbf{176 \text{ L/min}}$$

Discussion Note that the raising the isentropic efficiency of the compressor to 100% would increase the volumetric flow rate by more than 20%.

7-211E Helium is accelerated by a 94% efficient nozzle from a low velocity to 1000 ft/s. The pressure and temperature at the nozzle inlet are to be determined.

Assumptions 1 This is a steady-flow process since there is no change with time. **2** Helium is an ideal gas with constant specific heats. **3** Potential energy changes are negligible. **4** The device is adiabatic and thus heat transfer is negligible.

Properties The specific heat ratio of helium is $k = 1.667$. The constant pressure specific heat of helium is 1.25 Btu/lbm·R (Table A-2E).

Analysis We take nozzle as the system, which is a control volume since mass crosses the boundary. The energy balance for this steady-flow system can be expressed in the rate form as

$$\underbrace{\dot{E}_{\text{in}} - \dot{E}_{\text{out}}}_{\text{Rate of net energy transfer by heat, work, and mass}} = \underbrace{\Delta \dot{E}_{\text{system}}^{\phi_0} (\text{steady})}_{\text{Rate of change in internal, kinetic, potential, etc. energies}} = 0$$

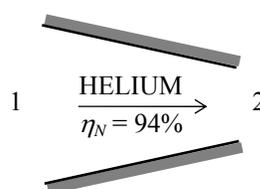
$$\dot{E}_{\text{in}} = \dot{E}_{\text{out}}$$

$$\dot{m}(h_1 + V_1^2/2) = \dot{m}(h_2 + V_2^2/2) \quad (\text{since } \dot{Q} \cong \dot{W} \cong \Delta p e \cong 0)$$

$$0 = h_2 - h_1 + \frac{V_2^2 - V_1^2}{2} \longrightarrow 0 = c_{p,\text{avg}}(T_2 - T_1) + \frac{V_2^2 - V_1^2}{2}$$

Solving for T_1 and substituting,

$$T_1 = T_{2a} + \frac{V_{2s}^2 - V_1^2}{2C_p} \stackrel{\phi_0}{=} 180^\circ\text{F} + \frac{(1000 \text{ ft/s})^2}{2(1.25 \text{ Btu/lbm} \cdot \text{R})} \left(\frac{1 \text{ Btu/lbm}}{25,037 \text{ ft}^2/\text{s}^2} \right) = \mathbf{196.0^\circ\text{F} = 656 \text{ R}}$$

From the isentropic efficiency relation,

$$\eta_N = \frac{h_{2a} - h_1}{h_{2s} - h_1} = \frac{c_p(T_{2a} - T_1)}{c_p(T_{2s} - T_1)}$$

or,

$$T_{2s} = T_1 + (T_{2a} - T_1)/\eta_N = 656 + (640 - 656)/(0.94) = 639 \text{ R}$$

From the isentropic relation, $\frac{T_{2s}}{T_1} = \left(\frac{P_2}{P_1} \right)^{(k-1)/k}$

$$P_1 = P_2 \left(\frac{T_1}{T_{2s}} \right)^{k/(k-1)} = (14 \text{ psia}) \left(\frac{656 \text{ R}}{639 \text{ R}} \right)^{1.667/0.667} = \mathbf{14.9 \text{ psia}}$$

7-212 [Also solved by EES on enclosed CD] An adiabatic compressor is powered by a direct-coupled steam turbine, which also drives a generator. The net power delivered to the generator and the rate of entropy generation are to be determined.

Assumptions **1** This is a steady-flow process since there is no change with time. **2** Kinetic and potential energy changes are negligible. **3** The devices are adiabatic and thus heat transfer is negligible. **4** Air is an ideal gas with variable specific heats.

Properties The gas constant of air is $R = 0.287 \text{ kJ/kg}\cdot\text{K}$ (Table A-1). From the steam tables (Tables A-4 through 6) and air table (Table A-17),

$$T_1 = 295 \text{ K} \longrightarrow h_1 = 295.17 \text{ kJ/kg}, s_1^\circ = 1.68515 \text{ kJ/kg}\cdot\text{K}$$

$$T_2 = 620 \text{ K} \longrightarrow h_2 = 628.07 \text{ kJ/kg}, s_2^\circ = 2.44356 \text{ kJ/kg}\cdot\text{K}$$

$$\left. \begin{array}{l} P_3 = 12.5 \text{ MPa} \\ T_3 = 500^\circ\text{C} \end{array} \right\} \begin{array}{l} h_3 = 3343.6 \text{ kJ/kg} \\ s_3 = 6.4651 \text{ kJ/kg}\cdot\text{K} \end{array}$$

$$\left. \begin{array}{l} P_4 = 10 \text{ kPa} \\ x_4 = 0.92 \end{array} \right\} \begin{array}{l} h_4 = h_f + x_4 h_{fg} = 191.81 + (0.92)(2392.1) = 2392.5 \text{ kJ/kg} \\ s_4 = s_f + x_4 s_{fg} = 0.6492 + (0.92)(7.4996) = 7.5489 \text{ kJ/kg}\cdot\text{K} \end{array}$$

Analysis There is only one inlet and one exit for either device, and thus $\dot{m}_{\text{in}} = \dot{m}_{\text{out}} = \dot{m}$. We take either the turbine or the compressor as the system, which is a control volume since mass crosses the boundary. The energy balance for either steady-flow system can be expressed in the rate form as

$$\underbrace{\dot{E}_{\text{in}} - \dot{E}_{\text{out}}}_{\text{Rate of net energy transfer by heat, work, and mass}} = \underbrace{\Delta \dot{E}_{\text{system}}^{\neq 0} (\text{steady})}_{\text{Rate of change in internal, kinetic, potential, etc. energies}} = 0 \rightarrow \dot{E}_{\text{in}} = \dot{E}_{\text{out}}$$

For the turbine and the compressor it becomes

$$\text{Compressor: } \dot{W}_{\text{comp, in}} + \dot{m}_{\text{air}} h_1 = \dot{m}_{\text{air}} h_2 \rightarrow \dot{W}_{\text{comp, in}} = \dot{m}_{\text{air}} (h_2 - h_1)$$

$$\text{Turbine: } \dot{m}_{\text{steam}} h_3 = \dot{W}_{\text{turb, out}} + \dot{m}_{\text{steam}} h_4 \rightarrow \dot{W}_{\text{turb, out}} = \dot{m}_{\text{steam}} (h_3 - h_4)$$

Substituting,

$$\dot{W}_{\text{comp, in}} = (10 \text{ kg/s})(628.07 - 295.17) \text{ kJ/kg} = 3329 \text{ kW}$$

$$\dot{W}_{\text{turb, out}} = (25 \text{ kg/s})(3343.6 - 2392.5) \text{ kJ/kg} = 23,777 \text{ kW}$$

Therefore,

$$\dot{W}_{\text{net, out}} = \dot{W}_{\text{turb, out}} - \dot{W}_{\text{comp, in}} = 23,777 - 3329 = \mathbf{20,448 \text{ kW}}$$

Noting that the system is adiabatic, the total rate of entropy change (or generation) during this process is the sum of the entropy changes of both fluids,

$$\dot{S}_{\text{gen}} = \dot{m}_{\text{air}} (s_2 - s_1) + \dot{m}_{\text{steam}} (s_4 - s_3)$$

where

$$\begin{aligned} \dot{m}_{\text{air}} (s_2 - s_1) &= \dot{m} \left(s_2^\circ - s_1^\circ - R \ln \frac{P_2}{P_1} \right) \\ &= (10 \text{ kg/s}) \left(2.44356 - 1.68515 - 0.287 \ln \frac{1000 \text{ kPa}}{98 \text{ kPa}} \right) \text{ kJ/kg}\cdot\text{K} = 0.92 \text{ kW/K} \end{aligned}$$

$$\dot{m}_{\text{steam}} (s_4 - s_3) = (25 \text{ kg/s})(7.5489 - 6.4651) \text{ kJ/kg}\cdot\text{K} = 27.1 \text{ kW/K}$$

Substituting, the total rate of entropy generation is determined to be

$$\dot{S}_{\text{gen, total}} = \dot{S}_{\text{gen, comp}} + \dot{S}_{\text{gen, turb}} = 0.92 + 27.1 = \mathbf{28.02 \text{ kW/K}}$$

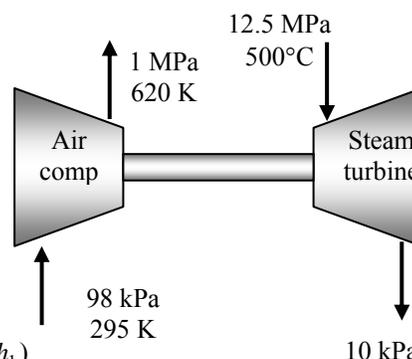

7-213 EES Problem 7-212 is reconsidered. The isentropic efficiencies for the compressor and turbine are to be determined, and then the effect of varying the compressor efficiency over the range 0.6 to 0.8 and the turbine efficiency over the range 0.7 to 0.95 on the net work for the cycle and the entropy generated for the process is to be investigated. The net work is to be plotted as a function of the compressor efficiency for turbine efficiencies of 0.7, 0.8, and 0.9.

Analysis The problem is solved using EES, and the results are tabulated and plotted below.

"Input Data"

$m_{\text{dot_air}} = 10$ [kg/s] "air compressor (air) data"

$T_{\text{air}[1]} = (295-273)$ [C] "We will input temperature in C"

$P_{\text{air}[1]} = 98$ [kPa]

$T_{\text{air}[2]} = (700-273)$ [C]

$P_{\text{air}[2]} = 1000$ [kPa]

$m_{\text{dot_st}} = 25$ [kg/s] "steam turbine (st) data"

$T_{\text{st}[1]} = 500$ [C]

$P_{\text{st}[1]} = 12500$ [kPa]

$P_{\text{st}[2]} = 10$ [kPa]

$x_{\text{st}[2]} = 0.92$ "quality"

"Compressor Analysis:"

"Conservation of mass for the compressor $m_{\text{dot_air_in}} = m_{\text{dot_air_out}} = m_{\text{dot_air}}$ "

"Conservation of energy for the compressor is:"

$E_{\text{dot_comp_in}} - E_{\text{dot_comp_out}} = \text{DELTA}E_{\text{dot_comp}}$

$\text{DELTA}E_{\text{dot_comp}} = 0$ "Steady flow requirement"

$E_{\text{dot_comp_in}} = m_{\text{dot_air}} * (\text{enthalpy}(\text{air}, T = T_{\text{air}[1]})) + W_{\text{dot_comp_in}}$

$E_{\text{dot_comp_out}} = m_{\text{dot_air}} * (\text{enthalpy}(\text{air}, T = T_{\text{air}[2]}))$

"Compressor adiabatic efficiency:"

$\text{Eta}_{\text{comp}} = W_{\text{dot_comp_in_isen}} / W_{\text{dot_comp_in}}$

$W_{\text{dot_comp_in_isen}} = m_{\text{dot_air}} * (\text{enthalpy}(\text{air}, T = T_{\text{air_isen}[2]}) - \text{enthalpy}(\text{air}, T = T_{\text{air}[1]}))$

$s_{\text{air}[1]} = \text{entropy}(\text{air}, T = T_{\text{air}[1]}, P = P_{\text{air}[1]})$

$s_{\text{air}[2]} = \text{entropy}(\text{air}, T = T_{\text{air}[2]}, P = P_{\text{air}[2]})$

$s_{\text{air_isen}[2]} = \text{entropy}(\text{air}, T = T_{\text{air_isen}[2]}, P = P_{\text{air}[2]})$

$s_{\text{air_isen}[2]} = s_{\text{air}[1]}$

"Turbine Analysis:"

"Conservation of mass for the turbine $m_{\text{dot_st_in}} = m_{\text{dot_st_out}} = m_{\text{dot_st}}$ "

"Conservation of energy for the turbine is:"

$E_{\text{dot_turb_in}} - E_{\text{dot_turb_out}} = \text{DELTA}E_{\text{dot_turb}}$

$\text{DELTA}E_{\text{dot_turb}} = 0$ "Steady flow requirement"

$E_{\text{dot_turb_in}} = m_{\text{dot_st}} * h_{\text{st}[1]}$

$h_{\text{st}[1]} = \text{enthalpy}(\text{steam}, T = T_{\text{st}[1]}, P = P_{\text{st}[1]})$

$E_{\text{dot_turb_out}} = m_{\text{dot_st}} * h_{\text{st}[2]} + W_{\text{dot_turb_out}}$

$h_{\text{st}[2]} = \text{enthalpy}(\text{steam}, P = P_{\text{st}[2]}, x = x_{\text{st}[2]})$

"Turbine adiabatic efficiency:"

$\text{Eta}_{\text{turb}} = W_{\text{dot_turb_out}} / W_{\text{dot_turb_out_isen}}$

$W_{\text{dot_turb_out_isen}} = m_{\text{dot_st}} * (h_{\text{st}[1]} - h_{\text{st_isen}[2]})$

$s_{\text{st}[1]} = \text{entropy}(\text{steam}, T = T_{\text{st}[1]}, P = P_{\text{st}[1]})$

$h_{\text{st_isen}[2]} = \text{enthalpy}(\text{steam}, P = P_{\text{st}[2]}, s = s_{\text{st}[1]})$

"Note: When Eta_{turb} is specified as an independent variable in the Parametric Table, the iteration process may put the steam state 2 in the superheat region, where the quality is undefined. Thus, $s_{\text{st}[2]}$, $T_{\text{st}[2]}$ are calculated at $P_{\text{st}[2]}$, $h_{\text{st}[2]}$ and not $P_{\text{st}[2]}$ and $x_{\text{st}[2]}$ "

$s_{\text{st}[2]} = \text{entropy}(\text{steam}, P = P_{\text{st}[2]}, h = h_{\text{st}[2]})$

$T_{\text{st}[2]} = \text{temperature}(\text{steam}, P = P_{\text{st}[2]}, h = h_{\text{st}[2]})$

$s_{\text{st_isen}[2]} = s_{\text{st}[1]}$

"Net work done by the process:"

$W_{\text{dot_net}} = W_{\text{dot_turb_out}} - W_{\text{dot_comp_in}}$

"Entropy generation:"

"Since both the compressor and turbine are adiabatic, and thus there is no heat transfer to the surroundings, the entropy generation for the two steady flow devices becomes:"

$$\dot{S}_{\text{gen,comp}} = \dot{m}_{\text{air}}(s_{\text{air}[2]} - s_{\text{air}[1]})$$

$$\dot{S}_{\text{gen,turb}} = \dot{m}_{\text{st}}(s_{\text{st}[2]} - s_{\text{st}[1]})$$

$$\dot{S}_{\text{gen,total}} = \dot{S}_{\text{gen,comp}} + \dot{S}_{\text{gen,turb}}$$

"To generate the data for Plot Window 1, Comment out the line 'T_air[2]=(700-273) C' and select values for Eta_comp in the Parametric Table, then press F3 to solve the table. EES then solves for the unknown value of T_air[2] for each Eta_comp."

"To generate the data for Plot Window 2, Comment out the two lines 'x_st[2]=0.92 quality' and 'h_st[2]=enthalpy(steam,P=P_st[2], x=x_st[2])' and select values for Eta_turb in the Parametric Table, then press F3 to solve the table. EES then solves for the h_st[2] for each Eta_turb."

\dot{W}_{net} [kW]	$\dot{S}_{\text{gen,total}}$ [kW/K]	η_{turb}	η_{comp}
20124	27.59	0.75	0.6665
21745	22.51	0.8	0.6665
23365	17.44	0.85	0.6665
24985	12.36	0.9	0.6665
26606	7.281	0.95	0.6665

\dot{W}_{net} [kW]	$\dot{S}_{\text{gen,total}}$ [kW/K]	η_{turb}	η_{comp}
19105	30	0.7327	0.6
19462	29.51	0.7327	0.65
19768	29.07	0.7327	0.7
20033	28.67	0.7327	0.75
20265	28.32	0.7327	0.8

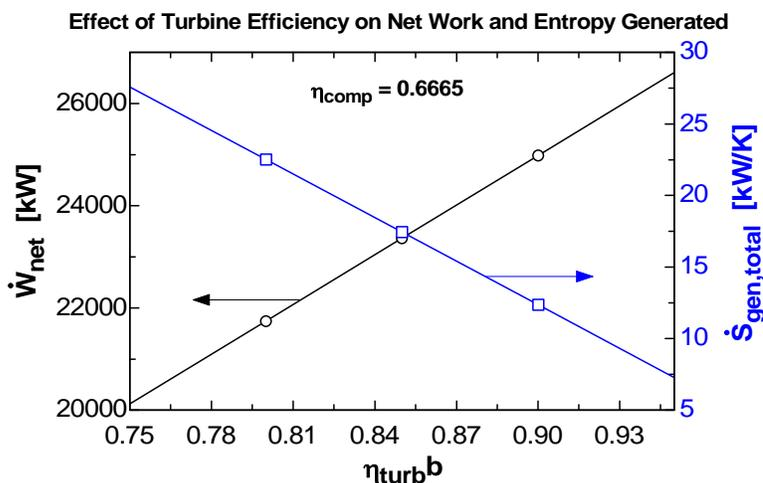
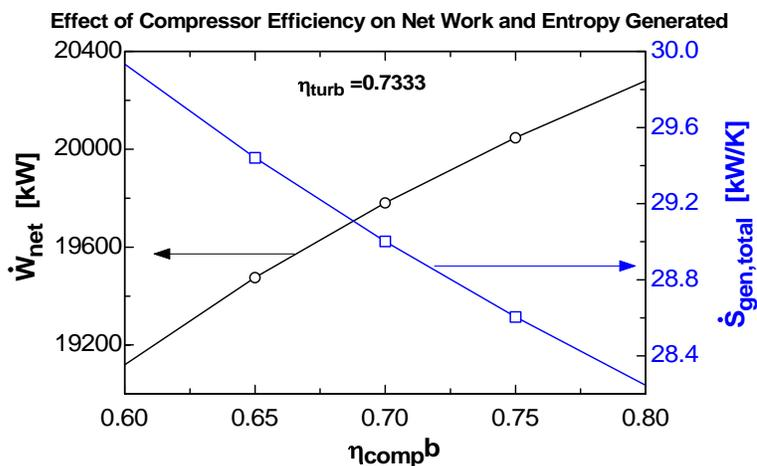

7-214 The pressure in a hot water tank rises to 2 MPa, and the tank explodes. The explosion energy of the water is to be determined, and expressed in terms of its TNT equivalence.

Assumptions 1 The expansion process during explosion is isentropic. **2** Kinetic and potential energy changes are negligible. **3** Heat transfer with the surroundings during explosion is negligible.

Properties The explosion energy of TNT is 3250 kJ/kg. From the steam tables (Tables A-4 through 6)

$$P_1 = 2 \text{ MPa} \left. \begin{array}{l} v_1 = v_f @ 2 \text{ MPa} = 0.001177 \text{ m}^3/\text{kg} \\ u_1 = u_f @ 2 \text{ MPa} = 906.12 \text{ kJ/kg} \\ s_1 = s_f @ 2 \text{ MPa} = 2.4467 \text{ kJ/kg} \cdot \text{K} \end{array} \right\} \text{ sat. liquid}$$

$$P_2 = 100 \text{ kPa} \left. \begin{array}{l} u_f = 417.40, \quad u_{fg} = 2088.2 \text{ kJ/kg} \\ s_f = 1.3028, \quad s_{fg} = 6.0562 \text{ kJ/kg} \cdot \text{K} \end{array} \right\}$$

$$x_2 = \frac{s_2 - s_f}{s_{fg}} = \frac{2.4467 - 1.3028}{6.0562} = 0.1889$$

$$u_2 = u_f + x_2 u_{fg} = 417.40 + (0.1889)(2088.2) = 811.83 \text{ kJ/kg}$$

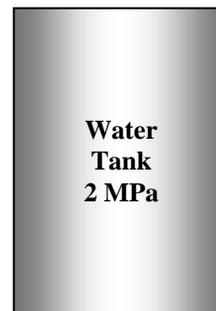

Analysis We idealize the water tank as a closed system that undergoes a reversible adiabatic process with negligible changes in kinetic and potential energies. The work done during this idealized process represents the explosive energy of the tank, and is determined from the closed system energy balance to be

$$\underbrace{E_{\text{in}} - E_{\text{out}}}_{\substack{\text{Net energy transfer} \\ \text{by heat, work, and mass}}} = \underbrace{\Delta E_{\text{system}}}_{\substack{\text{Change in internal, kinetic,} \\ \text{potential, etc. energies}}}$$

$$-W_{\text{b,out}} = \Delta U = m(u_2 - u_1)$$

$$E_{\text{exp}} = W_{\text{b,out}} = m(u_1 - u_2)$$

where

$$m = \frac{V}{v_1} = \frac{0.080 \text{ m}^3}{0.001177 \text{ m}^3/\text{kg}} = 67.99 \text{ kg}$$

Substituting,

$$E_{\text{exp}} = (67.99 \text{ kg})(906.12 - 811.83) \text{ kJ/kg} = 6410 \text{ kJ}$$

which is equivalent to

$$m_{\text{TNT}} = \frac{6410 \text{ kJ}}{3250 \text{ kJ/kg}} = \mathbf{1.972 \text{ kg TNT}}$$

7-215 A 0.35-L canned drink explodes at a pressure of 1.2 MPa. The explosive energy of the drink is to be determined, and expressed in terms of its TNT equivalence.

Assumptions 1 The expansion process during explosion is isentropic. **2** Kinetic and potential energy changes are negligible. **3** Heat transfer with the surroundings during explosion is negligible. **4** The drink can be treated as pure water.

Properties The explosion energy of TNT is 3250 kJ/kg. From the steam tables (Tables A-4 through 6)

$$P_1 = 1.2 \text{ MPa} \left\{ \begin{array}{l} v_1 = v_f @ 1.2 \text{ MPa} = 0.001138 \text{ m}^3/\text{kg} \\ u_1 = u_f @ 1.2 \text{ MPa} = 796.96 \text{ kJ/kg} \\ s_1 = s_f @ 1.2 \text{ MPa} = 2.2159 \text{ kJ/kg} \cdot \text{K} \end{array} \right.$$

$$P_2 = 100 \text{ kPa} \left\{ \begin{array}{l} u_f = 417.40, \quad u_{fg} = 2088.2 \text{ kJ/kg} \\ s_f = 1.3028, \quad s_{fg} = 6.0562 \text{ kJ/kg} \cdot \text{K} \end{array} \right.$$

$$x_2 = \frac{s_2 - s_f}{s_{fg}} = \frac{2.2159 - 1.3028}{6.0562} = 0.1508$$

$$u_2 = u_f + x_2 u_{fg} = 417.40 + (0.1508)(2088.2) = 732.26 \text{ kJ/kg}$$

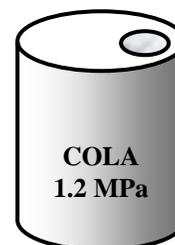

Analysis We idealize the canned drink as a closed system that undergoes a reversible adiabatic process with negligible changes in kinetic and potential energies. The work done during this idealized process represents the explosive energy of the can, and is determined from the closed system energy balance to be

$$\underbrace{E_{\text{in}} - E_{\text{out}}}_{\substack{\text{Net energy transfer} \\ \text{by heat, work, and mass}}} = \underbrace{\Delta E_{\text{system}}}_{\substack{\text{Change in internal, kinetic,} \\ \text{potential, etc. energies}}}$$

$$-W_{\text{b,out}} = \Delta U = m(u_2 - u_1)$$

$$E_{\text{exp}} = W_{\text{b,out}} = m(u_1 - u_2)$$

where

$$m = \frac{V}{v_1} = \frac{0.00035 \text{ m}^3}{0.001138 \text{ m}^3/\text{kg}} = 0.3074 \text{ kg}$$

Substituting,

$$E_{\text{exp}} = (0.3074 \text{ kg})(796.96 - 732.26) \text{ kJ/kg} = \mathbf{19.9 \text{ kJ}}$$

which is equivalent to

$$m_{\text{TNT}} = \frac{19.9 \text{ kJ}}{3250 \text{ kJ/kg}} = \mathbf{0.00612 \text{ kg TNT}}$$

7-216 The validity of the Clausius inequality is to be demonstrated using a reversible and an irreversible heat engine operating between the same temperature limits.

Analysis Consider two heat engines, one reversible and one irreversible, both operating between a high-temperature reservoir at T_H and a low-temperature reservoir at T_L . Both heat engines receive the same amount of heat, Q_H . The reversible heat engine rejects heat in the amount of Q_L , and the irreversible one in the amount of $Q_{L, \text{irrev}} = Q_L + Q_{\text{diff}}$, where Q_{diff} is a positive quantity since the irreversible heat engine produces less work. Noting that Q_H and Q_L are transferred at constant temperatures of T_H and T_L , respectively, the cyclic integral of $\delta Q/T$ for the reversible and irreversible heat engine cycles become

$$\oint \left(\frac{\delta Q}{T} \right)_{\text{rev}} = \int \frac{\delta Q_H}{T_H} - \int \frac{\delta Q_L}{T_L} = \frac{1}{T_H} \int \delta Q_H - \frac{1}{T_L} \int \delta Q_L = \frac{Q_H}{T_H} - \frac{Q_L}{T_L} = 0$$

since $(Q_H/T_H) = (Q_L/T_L)$ for reversible cycles. Also,

$$\oint \left(\frac{\delta Q}{T} \right)_{\text{irrev}} = \frac{Q_H}{T_H} - \frac{Q_{L, \text{irrev}}}{T_L} = \frac{Q_H}{T_H} - \frac{Q_L}{T_L} - \frac{Q_{\text{diff}}}{T_L} = -\frac{Q_{\text{diff}}}{T_L} < 0$$

since Q_{diff} is a positive quantity. Thus, $\oint \left(\frac{\delta Q}{T} \right) \leq 0$.

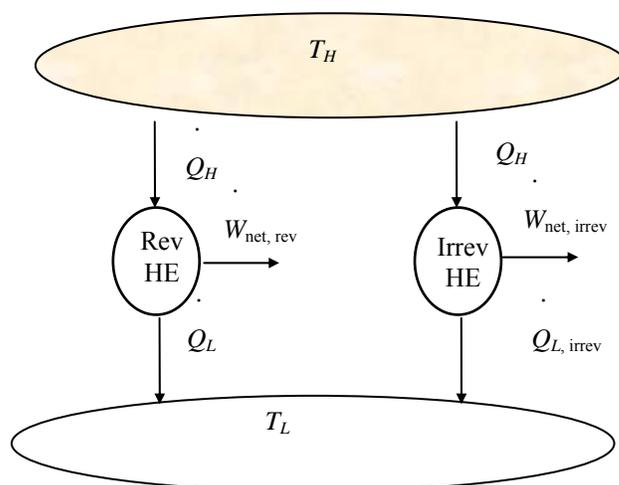

7-217E R-134a vapor from a storage tank is used to drive an isentropic turbine. The work produced by the turbine is to be determined.

Assumptions 1 This is an unsteady-flow process since the conditions in the tank changes. **2** Kinetic and potential energy changes are negligible. **3** The device is adiabatic and thus heat transfer is negligible.

Analysis The inlet and exit enthalpies for the turbine are (Tables A-11E through A-13E),

$$\left. \begin{array}{l} T_1 = 80^\circ\text{F} \\ x_1 = 1 \text{ (sat. vap.)} \end{array} \right\} \begin{array}{l} h_1 = h_g = 113.94 \text{ Btu/lbm} \\ s_1 = 0.21972 \text{ Btu/lbm} \cdot \text{R} \end{array}$$

$$\left. \begin{array}{l} P_{2s} = 10 \text{ psia} \\ s_2 = s_1 \end{array} \right\} \begin{array}{l} x_2 = \frac{s_{2s} - s_f}{s_{fg}} = \frac{0.21972 - 0.00742}{0.22206} = 0.95605 \\ h_2 = h_f + x_2 h_{fg} = 3.156 + (0.95605)(95.528) = 94.49 \text{ Btu/lbm} \end{array}$$

The initial mass of R-134a in the tank is

$$m_{\text{initial}} = \frac{V}{v_{f@80^\circ\text{F}}} = \frac{10 \text{ ft}^3}{0.01334 \text{ ft}^3/\text{lbm}} = 749.6 \text{ lbm}$$

The amount of mass which passes through the turbine during this expansion is then

$$m = \frac{m_{\text{initial}}}{2} = \frac{749.6 \text{ lbm}}{2} = 374.8 \text{ lbm}$$

The amount of work produced from the turbine is then

$$W_{\text{out}} = m(h_1 - h_2) = (374.8 \text{ lbm})(113.94 - 94.49) \text{ Btu/lbm} = \mathbf{7290 \text{ Btu}}$$

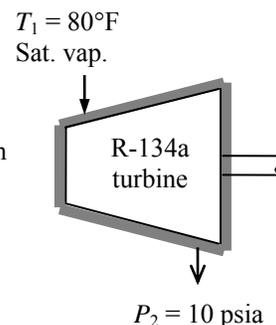

7-218 R-134a is expanded in an adiabatic process with an isentropic efficiency of 0.80. The work produced and final enthalpy are to be determined.

Assumptions 1 Kinetic and potential energy changes are negligible. **2** The device is adiabatic and thus heat transfer is negligible.

Analysis We take the R-134a as the system. This is a closed system since no mass enters or leaves. The energy balance for this stationary closed system can be expressed as

$$\underbrace{E_{\text{in}} - E_{\text{out}}}_{\substack{\text{Net energy transfer} \\ \text{by heat, work, and mass}}} = \underbrace{\Delta E_{\text{system}}}_{\substack{\text{Change in internal, kinetic,} \\ \text{potential, etc. energies}}}$$

$$-W_{\text{out}} = \Delta U = m(u_2 - u_1)$$

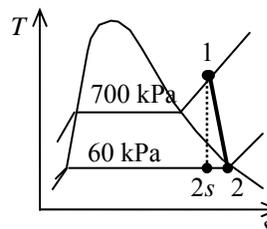

From the R-134a tables (Tables A-11 through A-13),

$$\left. \begin{array}{l} P_1 = 700 \text{ kPa} \\ T_1 = 40^\circ\text{C} \end{array} \right\} \begin{array}{l} u_1 = 256.39 \text{ kJ/kg} \\ s_1 = 0.9641 \text{ kJ/kg}\cdot\text{K} \end{array}$$

$$\left. \begin{array}{l} P_2 = 60 \text{ kPa} \\ s_2 = s_1 \end{array} \right\} \begin{array}{l} x_2 = \frac{s_2 - s_f}{s_{fg}} = \frac{0.9641 - 0.01634}{0.94807} = 0.9997 \\ u_{2s} = u_f + x_{2s} u_{fg} = 3.798 + (0.9997)(205.32) = 209.05 \text{ kJ/kg} \end{array}$$

The actual work input is

$$w_{a,\text{out}} = \eta_s w_{s,\text{out}} = \eta_T (u_1 - u_{2s}) = (0.80)(256.39 - 209.05) \text{ kJ/kg} = \mathbf{37.87 \text{ kJ/kg}}$$

The actual internal energy at the end of the expansion process is

$$w_{a,\text{out}} = (u_1 - u_{2a}) \longrightarrow u_2 = u_1 - w_{a,\text{out}} = 256.39 - 37.87 = 218.52 \text{ kJ/kg}$$

The enthalpy at the final state is

$$\left. \begin{array}{l} P_2 = 60 \text{ kPa} \\ u_2 = 218.52 \text{ kJ/kg} \end{array} \right\} h_2 = \mathbf{238.42 \text{ kJ/kg}} \quad (\text{Table A-13})$$

7-219E A system consisting of a compressor, a storage tank, and a turbine as shown in the figure is considered. The total work required to fill the tank and the total heat transferred from the air in the tank as it is being filled are to be determined.

Assumptions 1 Changes in the kinetic and potential energies are negligible. **4** Air is an ideal gas with constant specific heats.

Properties The properties of air at room temperature are $R = 0.3704 \text{ psia}\cdot\text{ft}^3/\text{lbm}\cdot\text{R}$, $c_p = 0.240 \text{ Btu}/\text{lbm}\cdot\text{R}$, $c_v = 0.171 \text{ Btu}/\text{lbm}\cdot\text{R}$, $k = 1.4$ (Table A-2Ea).

Analysis The initial mass of air in the tank is

$$m_{\text{initial}} = \frac{P_{\text{initial}}\mathcal{V}}{RT_{\text{initial}}} = \frac{(14.696 \text{ psia})(1 \times 10^6 \text{ ft}^3)/\text{lbm}\cdot\text{R}}{(0.3704 \text{ psia}\cdot\text{ft}^3/\text{lbm}\cdot\text{R})(530 \text{ R})} = 74,860 \text{ lbm}$$

and the final mass in the tank is

$$m_{\text{final}} = \frac{P_{\text{final}}\mathcal{V}}{RT_{\text{final}}} = \frac{(146.96 \text{ psia})(1 \times 10^6 \text{ ft}^3)/\text{lbm}\cdot\text{R}}{(0.3704 \text{ psia}\cdot\text{ft}^3/\text{lbm}\cdot\text{R})(530 \text{ R})} = 748,600 \text{ lbm}$$

Since the compressor operates as an isentropic device,

$$T_2 = T_1 \left(\frac{P_2}{P_1} \right)^{(k-1)/k}$$

where P_2 matches the pressure in the tank. The conservation of mass applied to the tank gives

$$\frac{dm}{dt} = \dot{m}_2$$

while the first law gives

$$\dot{Q} = \frac{d(mu)}{dt} - h_2 \frac{dm}{dt}$$

Employing the ideal gas equation of state and using constant specific heats, expands this result to

$$\dot{Q} = \frac{\mathcal{V}c_v}{R} \frac{dP}{dt} - c_p T_2 \frac{\mathcal{V}}{RT} \frac{dP}{dt}$$

Using the temperature relation across the compressor and multiplying by dt puts this result in the form

$$\dot{Q}dt = \frac{\mathcal{V}c_v}{R} dP - c_p T_1 \left(\frac{P}{P_1} \right)^{(k-1)/k} \frac{\mathcal{V}}{RT} dP$$

When this integrated, it yields (i and f stand for initial and final states)

$$\begin{aligned} Q &= \frac{\mathcal{V}c_v}{R} (P_f - P_i) - \frac{k}{2k-1} \frac{c_p \mathcal{V}}{R} \left[P_f \left(\frac{P_f}{P_i} \right)^{(k-1)/k} - P_i \right] \\ &= \frac{(1 \times 10^6)(0.171)}{0.3704} (147 - 14.7) - \frac{1.4}{2(1.4) - 1} \frac{(0.24)(1 \times 10^6)}{0.3704} \left[147 \left(\frac{147}{14.7} \right)^{0.4/1.4} - 14.7 \right] \\ &= -7.454 \times 10^7 \text{ Btu} \end{aligned}$$

The negative result show that heat is transferred from the tank. Applying the first law to the tank and compressor gives

$$(\dot{Q} + \dot{W})dt = d(mu) - h_1 dm$$

which integrates to

$$Q + W = (m_f u_f - m_i u_i) - h_1 (m_f - m_i)$$

Upon rearrangement,

$$W = -Q - (c_p - c_v)T(m_f - m_i)$$

$$= 7.454 \times 10^7 - (0.240 - 0.171)(530)(748,600 - 74,860) = 4.990 \times 10^7 \text{ Btu}$$

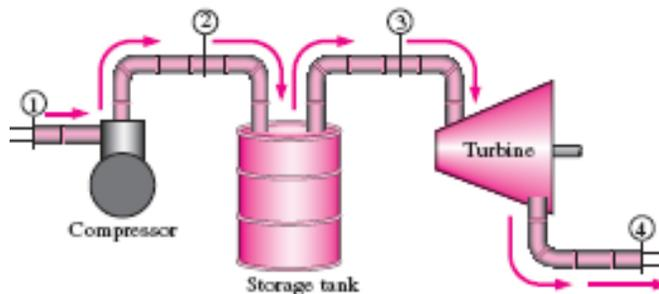

7-220E A system consisting of a compressor, a storage tank, and a turbine as shown in the figure is considered. The total work produced by the turbine and the total heat added to the air in the tank during the discharge are to be determined.

Assumptions 1 Changes in the kinetic and potential energies are negligible. **4** Air is an ideal gas with constant specific heats.

Properties The properties of air at room temperature are $R = 0.3704 \text{ psia}\cdot\text{ft}^3/\text{lbm}\cdot\text{R}$, $c_p = 0.240 \text{ Btu}/\text{lbm}\cdot\text{R}$, $c_v = 0.171 \text{ Btu}/\text{lbm}\cdot\text{R}$, $k = 1.4$ (Table A-2Ea).

Analysis The initial mass of air in the tank is

$$m_{\text{initial}} = \frac{P_{\text{initial}} \mathcal{V}}{RT_{\text{initial}}} = \frac{(146.96 \text{ psia})(1 \times 10^6 \text{ ft}^3)/\text{lbm}\cdot\text{R}}{(0.3704 \text{ psia}\cdot\text{ft}^3/\text{lbm}\cdot\text{R})(530 \text{ R})} = 748,600 \text{ lbm}$$

and the final mass in the tank is

$$m_{\text{final}} = \frac{P_{\text{final}} \mathcal{V}}{RT_{\text{final}}} = \frac{(14.696 \text{ psia})(1 \times 10^6 \text{ ft}^3)/\text{lbm}\cdot\text{R}}{(0.3704 \text{ psia}\cdot\text{ft}^3/\text{lbm}\cdot\text{R})(530 \text{ R})} = 74,860 \text{ lbm}$$

At any time,

$$m_t = \frac{P \mathcal{V}}{RT}$$

and

$$\frac{dm_t}{dt} = \frac{\mathcal{V}}{RT} \frac{dP}{dt}$$

Since the turbine operates as an isentropic device,

$$T_4 = T_3 \left(\frac{P_4}{P_3} \right)^{(k-1)/k}$$

where P_4 is the constant atmospheric pressure and P_3 matches the pressure in the tank. The conservation of mass applied to the tank gives

$$\frac{dm}{dt} = -\dot{m}$$

while the first law applied to the turbine is

$$\dot{W} = \dot{m}(h_3 - h_4) = \dot{m}c_p(T_3 - T_4) = -\frac{dm}{dt}c_p(T_3 - T_4)$$

Substitution of the preceding results expands this result to

$$\dot{W} = c_p T_3 \left[\left(\frac{P_4}{P_3} \right)^{(k-1)/k} - 1 \right] \frac{\mathcal{V}}{RT_3} \frac{dP}{dt}$$

Noting that P_3 is the pressure in the tank and that P_4 is the constant atmospheric pressure, multiplying of this result by dt and integration from the initial to the final state gives

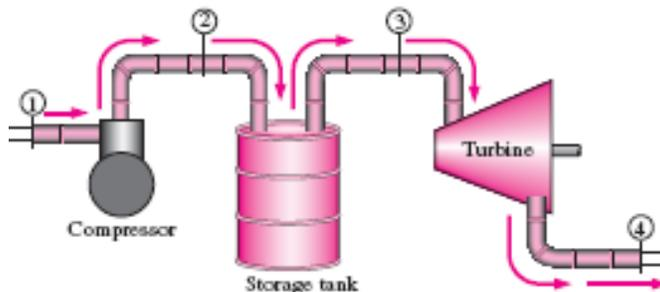

$$\begin{aligned}
 W &= \frac{c_p \mathcal{V}}{R} \int_i^f \left[\left(\frac{P_2}{P_1} \right)^{(k-1)/k} - 1 \right] dP \\
 &= \frac{c_p \mathcal{V}}{R} \left\{ k P_f \left[1 - \left(\frac{P_1}{P_2} \right)^{1/k} \right] - (P_f - P_i) \right\} \\
 &= \frac{(0.240)(1 \times 10^6)}{0.3704} \left\{ (1.4)(14.7) \left[1 - \left(\frac{147}{14.7} \right)^{1/1.4} \right] - (14.7 - 147) \right\} \\
 &= \mathbf{2.999 \times 10^7 \text{ Btu}}
 \end{aligned}$$

Adoption of the first law to the tank yields

$$\begin{aligned}
 Q &= (m_f u_f - m_i u_i) + h(m_f - m_i) \\
 &= (m_f - m_i) T (c_p + c_v) \\
 &= (748,600 - 74,860)(530)(0.240 + 0.171) \\
 &= \mathbf{-1.468 \times 10^8 \text{ Btu}}
 \end{aligned}$$

The negative result shows that heat is transferred from the turbine.

7-221 Two rigid tanks that contain water at different states are connected by a valve. The valve is opened and steam flows from tank A to tank B until the pressure in tank A drops to a specified value. Tank B loses heat to the surroundings. The final temperature in each tank and the entropy generated during this process are to be determined.

Assumptions 1 Tank A is insulated, and thus heat transfer is negligible. **2** The water that remains in tank A undergoes a reversible adiabatic process. **3** The thermal energy stored in the tanks themselves is negligible. **4** The system is stationary and thus kinetic and potential energy changes are negligible. **5** There are no work interactions.

Analysis (a) The steam in tank A undergoes a reversible, adiabatic process, and thus $s_2 = s_1$. From the steam tables (Tables A-4 through A-6),

Tank A:

$$P_1 = 400 \text{ kPa} \quad \left. \begin{array}{l} \nu_{1,A} = \nu_f + x_1 \nu_{fg} = 0.001084 + (0.8)(0.46242 - 0.001084) = 0.37015 \text{ m}^3/\text{kg} \\ x_1 = 0.8 \quad \left\{ \begin{array}{l} u_{1,A} = u_f + x_1 u_{fg} = 604.22 + (0.8)(1948.9) = 2163.3 \text{ kJ/kg} \\ s_{1,A} = s_f + x_1 s_{fg} = 1.7765 + (0.8)(5.1191) = 5.8717 \text{ kJ/kg} \cdot \text{K} \end{array} \right. \end{array} \right.$$

$$T_{2,A} = T_{\text{sat}@300 \text{ kPa}} = \mathbf{133.52^\circ\text{C}}$$

$$P_1 = 300 \text{ kPa} \quad \left. \begin{array}{l} x_{2,A} = \frac{s_{2,A} - s_f}{s_{fg}} = \frac{5.8717 - 1.6717}{5.3200} = 0.7895 \\ s_2 = s_1 \quad \left\{ \begin{array}{l} \nu_{2,A} = \nu_f + x_{2,A} \nu_{fg} = 0.001073 + (0.7895)(0.60582 - 0.001073) = 0.47850 \text{ m}^3/\text{kg} \\ u_{2,A} = u_f + x_{2,A} u_{fg} = 561.11 + (0.7895)(1982.1 \text{ kJ/kg}) = 2125.9 \text{ kJ/kg} \end{array} \right. \end{array} \right. \text{ (sat. mixture)}$$

Tank B:

$$P_1 = 200 \text{ kPa} \quad \left. \begin{array}{l} \nu_{1,B} = 1.1989 \text{ m}^3/\text{kg} \\ T_1 = 250^\circ\text{C} \quad \left\{ \begin{array}{l} u_{1,B} = 2731.4 \text{ kJ/kg} \\ s_{1,B} = 7.7100 \text{ kJ/kg} \cdot \text{K} \end{array} \right. \end{array} \right.$$

The initial and the final masses in tank A are

$$m_{1,A} = \frac{\nu_A}{\nu_{1,A}} = \frac{0.2 \text{ m}^3}{0.37015 \text{ m}^3/\text{kg}} = 0.5403 \text{ kg}$$

and

$$m_{2,A} = \frac{\nu_A}{\nu_{2,A}} = \frac{0.2 \text{ m}^3}{0.47850 \text{ m}^3/\text{kg}} = 0.4180 \text{ kg}$$

Thus, $0.5403 - 0.4180 = 0.1223 \text{ kg}$ of mass flows into tank B. Then,

$$m_{2,B} = m_{1,B} + 0.1223 = 3 + 0.1223 = 3.1223 \text{ kg}$$

The final specific volume of steam in tank B is determined from

$$\nu_{2,B} = \frac{\nu_B}{m_{2,B}} = \frac{(m_1 \nu_1)_B}{m_{2,B}} = \frac{(3 \text{ kg})(1.1989 \text{ m}^3/\text{kg})}{3.1223 \text{ kg}} = 1.1519 \text{ m}^3/\text{kg}$$

We take the entire contents of both tanks as the system, which is a closed system. The energy balance for this stationary closed system can be expressed as

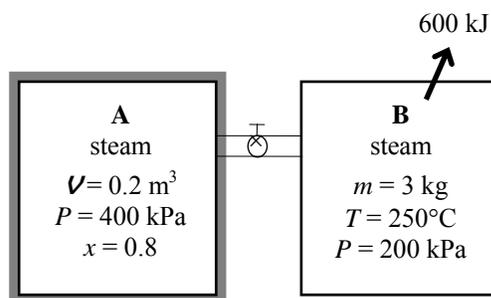

$$\underbrace{E_{\text{in}} - E_{\text{out}}}_{\substack{\text{Net energy transfer} \\ \text{by heat, work, and mass}}} = \underbrace{\Delta E_{\text{system}}}_{\substack{\text{Change in internal, kinetic,} \\ \text{potential, etc. energies}}}$$

$$-Q_{\text{out}} = \Delta U = (\Delta U)_A + (\Delta U)_B \quad (\text{since } W = \text{KE} = \text{PE} = 0)$$

$$-Q_{\text{out}} = (m_2 u_2 - m_1 u_1)_A + (m_2 u_2 - m_1 u_1)_B$$

Substituting,

$$-600 = \{(0.418)(2125.9) - (0.5403)(2163.3)\} + \{(3.1223)u_{2,B} - (3)(2731.4)\}$$

$$u_{2,B} = 2522.0 \text{ kJ/kg}$$

Thus,

$$\left. \begin{aligned} v_{2,B} &= 1.1519 \text{ m}^3/\text{kg} \\ u_{2,B} &= 2522.0 \text{ kJ/kg} \end{aligned} \right\} \begin{aligned} T_{2,B} &= \mathbf{113.2^\circ\text{C}} \\ s_{2,B} &= 7.2274 \text{ kJ/kg}\cdot\text{K} \end{aligned}$$

(b) The total entropy generation during this process is determined by applying the entropy balance on an *extended system* that includes both tanks and their immediate surroundings so that the boundary temperature of the extended system is the temperature of the surroundings at all times. It gives

$$\underbrace{S_{\text{in}} - S_{\text{out}}}_{\substack{\text{Net entropy transfer} \\ \text{by heat and mass}}} + \underbrace{S_{\text{gen}}}_{\substack{\text{Entropy} \\ \text{generation}}} = \underbrace{\Delta S_{\text{system}}}_{\substack{\text{Change} \\ \text{in entropy}}}$$

$$-\frac{Q_{\text{out}}}{T_{\text{b,surr}}} + S_{\text{gen}} = \Delta S_A + \Delta S_B$$

Rearranging and substituting, the total entropy generated during this process is determined to be

$$S_{\text{gen}} = \Delta S_A + \Delta S_B + \frac{Q_{\text{out}}}{T_{\text{b,surr}}} = (m_2 s_2 - m_1 s_1)_A + (m_2 s_2 - m_1 s_1)_B + \frac{Q_{\text{out}}}{T_{\text{b,surr}}}$$

$$= \{(0.418)(5.8717) - (0.5403)(5.8717)\} + \{(3.1223)(7.2274) - (3)(7.7100)\} + \frac{600 \text{ kJ}}{273 \text{ K}}$$

$$= \mathbf{0.916 \text{ kJ/K}}$$

7-222 Heat is transferred steadily to boiling water in a pan through its bottom. The rate of entropy generation within the bottom plate is to be determined.

Assumptions Steady operating conditions exist since the surface temperatures of the pan remain constant at the specified values.

Analysis We take the bottom of the pan to be the system,

which is a closed system. Under steady conditions, the rate form of the entropy balance for this system can be expressed as

$$\underbrace{\dot{S}_{\text{in}} - \dot{S}_{\text{out}}}_{\text{Rate of net entropy transfer by heat and mass}} + \underbrace{\dot{S}_{\text{gen}}}_{\text{Rate of entropy generation}} = \underbrace{\Delta\dot{S}_{\text{system}}}_{\text{Rate of change of entropy}} \stackrel{\neq 0}{=} 0$$

$$\frac{\dot{Q}_{\text{in}}}{T_{\text{b,in}}} - \frac{\dot{Q}_{\text{out}}}{T_{\text{b,out}}} + \dot{S}_{\text{gen,system}} = 0$$

$$\frac{500 \text{ W}}{378 \text{ K}} - \frac{500 \text{ W}}{377 \text{ K}} + \dot{S}_{\text{gen,system}} = 0 \rightarrow \dot{S}_{\text{gen,system}} = \mathbf{0.00351 \text{ W/K}}$$

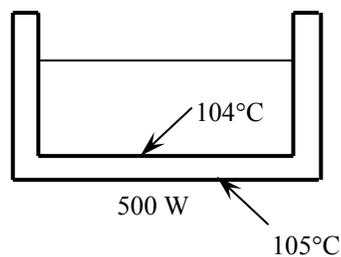

Discussion Note that there is a small temperature drop across the bottom of the pan, and thus a small amount of entropy generation.

7-223 An electric resistance heater is immersed in water. The time it will take for the electric heater to raise the water temperature to a specified temperature and the entropy generated during this process are to be determined.

Assumptions **1** Water is an incompressible substance with constant specific heats. **2** The energy stored in the container itself and the heater is negligible. **3** Heat loss from the container is negligible.

Properties The specific heat of water at room temperature is $c = 4.18 \text{ kJ/kg}\cdot^\circ\text{C}$ (Table A-3).

Analysis Taking the water in the container as the system, which is a closed system, the energy balance can be expressed as

$$\underbrace{E_{\text{in}} - E_{\text{out}}}_{\substack{\text{Net energy transfer} \\ \text{by heat, work, and mass}}} = \underbrace{\Delta E_{\text{system}}}_{\substack{\text{Change in internal, kinetic,} \\ \text{potential, etc. energies}}}$$

$$W_{\text{e,in}} = (\Delta U)_{\text{water}}$$

$$\dot{W}_{\text{e,in}} \Delta t = mc(T_2 - T_1)_{\text{water}}$$

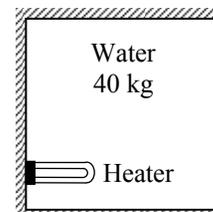

Substituting,

$$(1200 \text{ J/s})\Delta t = (40 \text{ kg})(4180 \text{ J/kg}\cdot^\circ\text{C})(50 - 20)^\circ\text{C}$$

Solving for Δt gives

$$\Delta t = 4180 \text{ s} = 69.7 \text{ min} = 1.16 \text{ h}$$

Again we take the water in the tank to be the system. Noting that no heat or mass crosses the boundaries of this system and the energy and entropy contents of the heater are negligible, the entropy balance for it can be expressed as

$$\underbrace{S_{\text{in}} - S_{\text{out}}}_{\substack{\text{Net entropy transfer} \\ \text{by heat and mass}}} + \underbrace{S_{\text{gen}}}_{\substack{\text{Entropy} \\ \text{generation}}} = \underbrace{\Delta S_{\text{system}}}_{\substack{\text{Change} \\ \text{in entropy}}}$$

$$0 + S_{\text{gen}} = \Delta S_{\text{water}}$$

Therefore, the entropy generated during this process is

$$S_{\text{gen}} = \Delta S_{\text{water}} = mc \ln \frac{T_2}{T_1} = (40 \text{ kg})(4.18 \text{ kJ/kg}\cdot\text{K}) \ln \frac{323 \text{ K}}{293 \text{ K}} = 16.3 \text{ kJ/K}$$

7-224 The feedwater of a steam power plant is preheated using steam extracted from the turbine. The ratio of the mass flow rates of the extracted steam to the feedwater and entropy generation per unit mass of feedwater are to be determined.

Assumptions **1** This is a steady-flow process since there is no change with time. **2** Kinetic and potential energy changes are negligible. **3** Heat loss from the device to the surroundings is negligible.

Properties The properties of steam and feedwater are (Tables A-4 through A-6)

$$P_1 = 1 \text{ MPa} \left\{ \begin{array}{l} h_1 = 2828.3 \text{ kJ/kg} \\ T_1 = 200^\circ\text{C} \end{array} \right. \left\{ \begin{array}{l} s_1 = 6.6956 \text{ kJ/kg}\cdot\text{K} \end{array} \right.$$

$$P_2 = 1 \text{ MPa} \left\{ \begin{array}{l} h_2 = h_{f@1 \text{ MPa}} = 762.51 \text{ kJ/kg} \\ \text{sat. liquid} \end{array} \right. \left\{ \begin{array}{l} s_2 = s_{f@1 \text{ MPa}} = 2.1381 \text{ kJ/kg}\cdot\text{K} \\ T_2 = 179.88^\circ\text{C} \end{array} \right.$$

$$P_3 = 2.5 \text{ MPa} \left\{ \begin{array}{l} h_3 \cong h_{f@50^\circ\text{C}} = 209.34 \text{ kJ/kg} \\ T_3 = 50^\circ\text{C} \end{array} \right. \left\{ \begin{array}{l} s_3 \cong s_{f@50^\circ\text{C}} = 0.7038 \text{ kJ/kg}\cdot\text{K} \end{array} \right.$$

$$P_4 = 2.5 \text{ MPa} \left\{ \begin{array}{l} h_4 \cong h_{f@170^\circ\text{C}} = 719.08 \text{ kJ/kg} \\ T_4 = T_2 - 10^\circ\text{C} \cong 170^\circ\text{C} \end{array} \right. \left\{ \begin{array}{l} s_4 \cong s_{f@170^\circ\text{C}} = 2.0417 \text{ kJ/kg}\cdot\text{K} \end{array} \right.$$

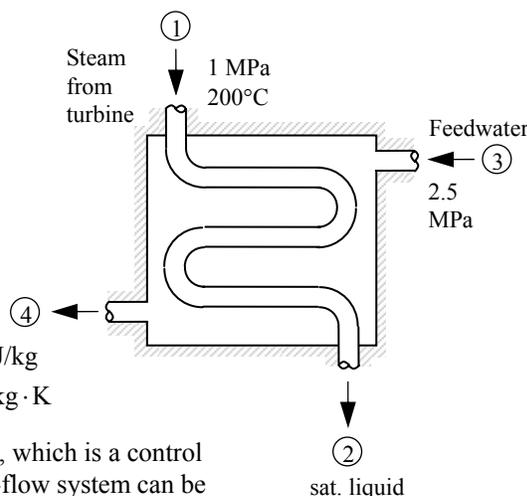

Analysis (a) We take the heat exchanger as the system, which is a control volume. The mass and energy balances for this steady-flow system can be expressed in the rate form as follows:

Mass balance (for each fluid stream):

$$\dot{m}_{\text{in}} - \dot{m}_{\text{out}} = \Delta \dot{m}_{\text{system}} \stackrel{\approx 0 \text{ (steady)}}{=} 0 \rightarrow \dot{m}_{\text{in}} = \dot{m}_{\text{out}} \rightarrow \dot{m}_1 = \dot{m}_2 = \dot{m}_s \quad \text{and} \quad \dot{m}_3 = \dot{m}_4 = \dot{m}_{fw}$$

Energy balance (for the heat exchanger):

$$\underbrace{\dot{E}_{\text{in}} - \dot{E}_{\text{out}}}_{\text{Rate of net energy transfer by heat, work, and mass}} = \underbrace{\Delta \dot{E}_{\text{system}}}_{\text{Rate of change in internal, kinetic, potential, etc. energies}} \stackrel{\approx 0 \text{ (steady)}}{=} 0$$

$$\dot{E}_{\text{in}} = \dot{E}_{\text{out}}$$

$$\dot{m}_1 h_1 + \dot{m}_3 h_3 = \dot{m}_2 h_2 + \dot{m}_4 h_4 \quad (\text{since } \dot{Q} = \dot{W} = \Delta ke \cong \Delta pe \cong 0)$$

Combining the two, $\dot{m}_s (h_2 - h_1) = \dot{m}_{fw} (h_3 - h_4)$

Dividing by \dot{m}_{fw} and substituting, $\frac{\dot{m}_s}{\dot{m}_{fw}} = \frac{h_4 - h_3}{h_1 - h_2} = \frac{(719.08 - 209.34) \text{ kJ/kg}}{(2828.3 - 762.51) \text{ kJ/kg}} = \mathbf{0.247}$

(b) The total entropy change (or entropy generation) during this process per unit mass of feedwater can be determined from an entropy balance expressed in the rate form as

$$\underbrace{\dot{S}_{\text{in}} - \dot{S}_{\text{out}}}_{\text{Rate of net entropy transfer by heat and mass}} + \underbrace{\dot{S}_{\text{gen}}}_{\text{Rate of entropy generation}} = \underbrace{\Delta \dot{S}_{\text{system}}}_{\text{Rate of change of entropy}} \stackrel{\approx 0}{=} 0$$

$$\dot{m}_1 s_1 - \dot{m}_2 s_2 + \dot{m}_3 s_3 - \dot{m}_4 s_4 + \dot{S}_{\text{gen}} = 0$$

$$\dot{m}_s (s_1 - s_2) + \dot{m}_{fw} (s_3 - s_4) + \dot{S}_{\text{gen}} = 0$$

$$\frac{\dot{S}_{\text{gen}}}{\dot{m}_{fw}} = \frac{\dot{m}_s}{\dot{m}_{fw}} (s_2 - s_1) + (s_4 - s_3) = (0.247)(2.1381 - 6.6956) + (2.0417 - 0.7038)$$

$$= \mathbf{0.213 \text{ kJ/K}} \quad \text{per kg of feedwater}$$

7-225 EES Problem 7-224 is reconsidered. The effect of the state of the steam at the inlet to the feedwater heater is to be investigated. The entropy of the extraction steam is assumed to be constant at the value for 1 MPa, 200°C, and the extraction steam pressure is to be varied from 1 MPa to 100 kPa. Both the ratio of the mass flow rates of the extracted steam and the feedwater heater and the total entropy change for this process per unit mass of the feedwater are to be plotted as functions of the extraction pressure.

Analysis The problem is solved using EES, and the results are tabulated and plotted below.

"Knowns:"

WorkFluid\$ = 'Steam_iapws'

"P[3] = 1000 [kPa]" "place {} around P[3] and T[3] eqations to solve the table"

T[3] = 200 [C]

P[4] = P[3]

x[4]=0

T[4]=temperature(WorkFluid\$,P=P[4],x=x[4])

P[1] = 2500 [kPa]

T[1] = 50 [C]

P[2] = 2500 [kPa]

T[2] = T[4] - 10"[C]"

"Since we don't know the mass flow rates and we want to determine the ratio of mass flow rate of the extracted steam and the feedwater, we can assume the mass flow rate of the feedwater is 1 kg/s without loss of generality. We write the conservation of energy."

"Conservation of mass for the steam extracted from the turbine: "

m_dot_steam[3]= m_dot_steam[4]

"Conservation of mass for the condensate flowing through the feedwater heater:"

m_dot_fw[1] = 1

m_dot_fw[2]= m_dot_fw[1]

"Conservation of Energy - SSSF energy balance for the feedwater heater -- neglecting the change in potential energy, no heat transfer, no work:"

h[3]=enthalpy(WorkFluid\$,P=P[3],T=T[3])

"To solve the table, place {} around s[3] and remove them from the 2nd and 3rd equations"

s[3]=entropy(WorkFluid\$,P=P[3],T=T[3])

{s[3] =6.693 [kJ/kg-K] "This s[3] is for the initial T[3], P[3]"

T[3]=temperature(WorkFluid\$,P=P[3],s=s[3]) "Use this equation for T[3] only when s[3] is given."

h[4]=enthalpy(WorkFluid\$,P=P[4],x=x[4])

s[4]=entropy(WorkFluid\$,P=P[4],x=x[4])

h[1]=enthalpy(WorkFluid\$,P=P[1],T=T[1])

s[1]=entropy(WorkFluid\$,P=P[1],T=T[1])

h[2]=enthalpy(WorkFluid\$,P=P[2],T=T[2])

s[2]=entropy(WorkFluid\$,P=P[2],T=T[2])

"For the feedwater heater:"

E_dot_in = E_dot_out

E_dot_in = m_dot_steam[3]*h[3] + m_dot_fw[1]*h[1]

E_dot_out= m_dot_steam[4]*h[4] + m_dot_fw[2]*h[2]

m_ratio = m_dot_steam[3]/ m_dot_fw[1]

"Second Law analysis:"

S_dot_in - S_dot_out + S_dot_gen = DELTAS_dot_sys

DELTAS_dot_sys = 0 "[KW/K]" "steady-flow result"

S_dot_in = m_dot_steam[3]*s[3] + m_dot_fw[1]*s[1]

S_dot_out= m_dot_steam[4]*s[4] + m_dot_fw[2]*s[2]

S_gen_PerUnitMassFWH = S_dot_gen/m_dot_fw[1]"[kJ/kg_fw-K]"

m_{ratio}	$S_{\text{gen,PerUnitMass}}$ [kJ/kg-K]	P_3 [kPa]
0.2109	0.1811	732
0.2148	0.185	760
0.219	0.189	790
0.223	0.1929	820
0.227	0.1968	850
0.2309	0.2005	880
0.2347	0.2042	910
0.2385	0.2078	940
0.2422	0.2114	970
0.2459	0.2149	1000

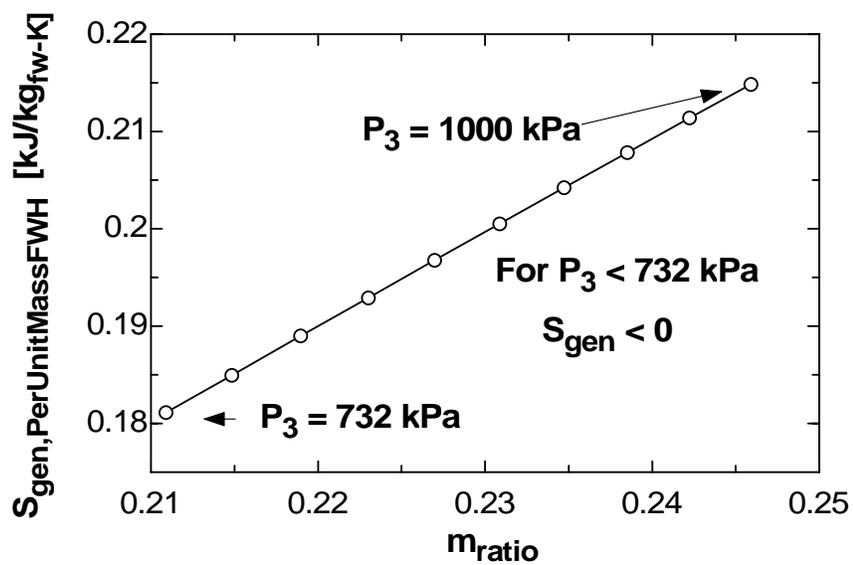

7-226E A rigid tank initially contains saturated R-134a vapor. The tank is connected to a supply line, and is charged until the tank contains saturated liquid at a specified pressure. The mass of R-134a that entered the tank, the heat transfer with the surroundings at 110°F, and the entropy generated during this process are to be determined.

Assumptions 1 This is an unsteady process since the conditions within the device are changing during the process, but it can be analyzed as a uniform-flow process since the state of fluid at the inlet remains constant. **2** Kinetic and potential energies are negligible. **3** There are no work interactions involved. **4** The direction of heat transfer is to the tank (will be verified).

Properties The properties of R-134a are (Tables A-11 through A-13)

$$\begin{aligned}
 P_1 = 100 \text{ psia} \left\{ \begin{array}{l} \nu_1 = \nu_{g@100 \text{ psia}} = 0.47760 \text{ ft}^3/\text{lbm} \\ u_1 = u_{g@100 \text{ psia}} = 104.99 \text{ Btu/lbm} \\ s_1 = s_{g@100 \text{ psia}} = 0.2198 \text{ Btu/lbm} \cdot \text{R} \end{array} \right. \\
 \text{sat. vapor} \\
 \\
 P_2 = 120 \text{ psia} \left\{ \begin{array}{l} \nu_2 = \nu_{f@120 \text{ psia}} = 0.01360 \text{ ft}^3/\text{lbm} \\ u_2 = u_{f@120 \text{ psia}} = 41.49 \text{ Btu/lbm} \\ s_2 = s_{f@120 \text{ psia}} = 0.08589 \text{ Btu/lbm} \cdot \text{R} \end{array} \right. \\
 \text{sat. liquid} \\
 \\
 P_i = 140 \text{ psia} \left\{ \begin{array}{l} h_i \cong h_{f@80^\circ\text{F}} = 38.17 \text{ Btu/lbm} \\ s_i \cong s_{f@80^\circ\text{F}} = 0.07934 \text{ Btu/lbm} \cdot \text{R} \end{array} \right. \\
 T_i = 80^\circ\text{F}
 \end{aligned}$$

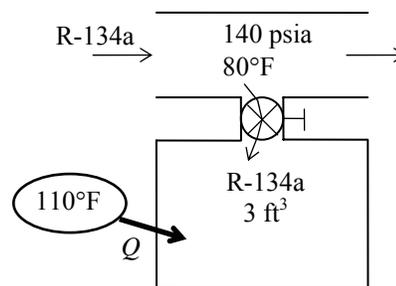

Analysis (a) We take the tank as the system, which is a control volume since mass crosses the boundary. Noting that the energies of flowing and nonflowing fluids are represented by enthalpy h and internal energy u , respectively, the mass and energy balances for this uniform-flow system can be expressed as

Mass balance:

$$m_{\text{in}} - m_{\text{out}} = \Delta m_{\text{system}} \rightarrow m_i = m_2 - m_1$$

Energy balance:

$$\underbrace{E_{\text{in}} - E_{\text{out}}}_{\substack{\text{Net energy transfer} \\ \text{by heat, work, and mass}}} = \underbrace{\Delta E_{\text{system}}}_{\substack{\text{Change in internal, kinetic,} \\ \text{potential, etc. energies}}}$$

$$Q_{\text{in}} + m_i h_i = m_2 u_2 - m_1 u_1 \quad (\text{since } W \cong \text{ke} \cong \text{pe} \cong 0)$$

The initial and the final masses in the tank are

$$\begin{aligned}
 m_1 &= \frac{\nu}{\nu_1} = \frac{3 \text{ ft}^3}{0.4776 \text{ ft}^3/\text{lbm}} = 6.28 \text{ lbm} \\
 m_2 &= \frac{\nu}{\nu_2} = \frac{3 \text{ ft}^3}{0.01360 \text{ ft}^3/\text{lbm}} = 220.55 \text{ lbm}
 \end{aligned}$$

Then from the mass balance,

$$m_i = m_2 - m_1 = 220.55 - 6.28 = \mathbf{214.3 \text{ lbm}}$$

(b) The heat transfer during this process is determined from the energy balance to be

$$\begin{aligned}
 Q_{\text{in}} &= -m_i h_i + m_2 u_2 - m_1 u_1 \\
 &= -(214.3 \text{ lbm})(38.17 \text{ Btu/lbm}) + (220.55 \text{ lbm})(41.49 \text{ Btu/lbm}) - (6.28 \text{ lbm})(104.99 \text{ Btu/lbm}) \\
 &= \mathbf{312 \text{ Btu}}
 \end{aligned}$$

(c) The entropy generated during this process is determined by applying the entropy balance on an *extended system* that includes the tank and its immediate surroundings so that the boundary temperature of the extended system is the temperature of the surroundings at all times. The entropy balance for it can be expressed as

$$\underbrace{S_{\text{in}} - S_{\text{out}}}_{\text{Net entropy transfer by heat and mass}} + \underbrace{S_{\text{gen}}}_{\text{Entropy generation}} = \underbrace{\Delta S_{\text{system}}}_{\text{Change in entropy}} \longrightarrow \frac{Q_{\text{in}}}{T_{\text{b,in}}} + m_i s_i + S_{\text{gen}} = \Delta S_{\text{tank}} = m_2 s_2 - m_1 s_1$$

Therefore, the total entropy generated during this process is

$$\begin{aligned} S_{\text{gen}} &= -m_i s_i + (m_2 s_2 - m_1 s_1) - \frac{Q_{\text{in}}}{T_{\text{b,in}}} \\ &= -(214.3)(0.07934) + (220.55)(0.08589) - (6.28)(0.2198) - \frac{312 \text{ Btu}}{570 \text{ R}} = \mathbf{0.0169 \text{ Btu/R}} \end{aligned}$$

7-227 It is to be shown that for thermal energy reservoirs, the entropy change relation $\Delta S = mc \ln(T_2 / T_1)$ reduces to $\Delta S = Q/T$ as $T_2 \rightarrow T_1$.

Analysis Consider a thermal energy reservoir of mass m , specific heat c , and initial temperature T_1 . Now heat, in the amount of Q , is transferred to this reservoir. The first law and the entropy change relations for this reservoir can be written as

$$Q = mc(T_2 - T_1) \longrightarrow mc = \frac{Q}{T_2 - T_1}$$

and

$$\Delta S = mc \ln \frac{T_2}{T_1} = Q \frac{\ln(T_2 / T_1)}{T_2 - T_1}$$

Taking the limit as $T_2 \rightarrow T_1$ by applying the L'Hospital's rule,

$$\Delta S = Q \frac{1/T_1}{1} = \frac{Q}{T_1}$$

which is the desired result.

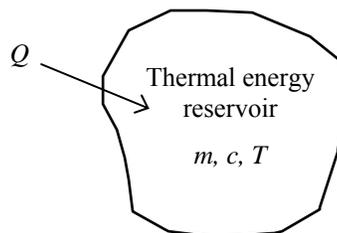

7-228 The heating of a passive solar house at night is to be assisted by solar heated water. The length of time that the electric heating system would run that night and the amount of entropy generated that night are to be determined.

Assumptions **1** Water is an incompressible substance with constant specific heats. **2** The energy stored in the glass containers themselves is negligible relative to the energy stored in water. **3** The house is maintained at 22°C at all times.

Properties The density and specific heat of water at room temperature are $\rho = 1 \text{ kg/L}$ and $c = 4.18 \text{ kJ/kg}\cdot^\circ\text{C}$ (Table A-3).

Analysis The total mass of water is

$$m_w = \rho V = (1 \text{ kg/L})(50 \times 20 \text{ L}) = 1000 \text{ kg}$$

Taking the contents of the house, including the water as our system, the energy balance relation can be written as

$$\begin{aligned} \underbrace{E_{\text{in}} - E_{\text{out}}}_{\substack{\text{Net energy transfer} \\ \text{by heat, work, and mass}}} &= \underbrace{\Delta E_{\text{system}}}_{\substack{\text{Change in internal, kinetic,} \\ \text{potential, etc. energies}}} \\ W_{\text{e,in}} - Q_{\text{out}} &= \Delta U = (\Delta U)_{\text{water}} + (\Delta U)_{\text{air}} \\ &= (\Delta U)_{\text{water}} \\ &= mc(T_2 - T_1)_{\text{water}} \end{aligned}$$

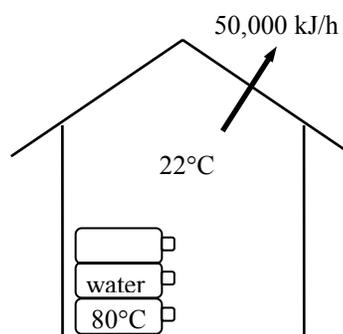

or,

$$\dot{W}_{\text{e,in}} \Delta t - Q_{\text{out}} = [mc(T_2 - T_1)]_{\text{water}}$$

Substituting,

$$(15 \text{ kJ/s})\Delta t - (50,000 \text{ kJ/h})(10 \text{ h}) = (1000 \text{ kg})(4.18 \text{ kJ/kg}\cdot^\circ\text{C})(22 - 80)^\circ\text{C}$$

It gives

$$\Delta t = 17,170 \text{ s} = \mathbf{4.77 \text{ h}}$$

We take the house as the system, which is a closed system. The entropy generated during this process is determined by applying the entropy balance on an *extended system* that includes the house and its immediate surroundings so that the boundary temperature of the extended system is the temperature of the surroundings at all times. The entropy balance for the extended system can be expressed as

$$\begin{aligned} \underbrace{S_{\text{in}} - S_{\text{out}}}_{\substack{\text{Net entropy transfer} \\ \text{by heat and mass}}} + \underbrace{S_{\text{gen}}}_{\substack{\text{Entropy} \\ \text{generation}}} &= \underbrace{\Delta S_{\text{system}}}_{\substack{\text{Change} \\ \text{in entropy}}} \\ -\frac{Q_{\text{out}}}{T_{\text{b,out}}} + S_{\text{gen}} &= \Delta S_{\text{water}} + \Delta S_{\text{air}} \stackrel{\approx 0}{=} \Delta S_{\text{water}} \end{aligned}$$

since the state of air in the house remains unchanged. Then the entropy generated during the 10-h period that night is

$$\begin{aligned} S_{\text{gen}} &= \Delta S_{\text{water}} + \frac{Q_{\text{out}}}{T_{\text{b,out}}} = \left(mc \ln \frac{T_2}{T_1} \right)_{\text{water}} + \frac{Q_{\text{out}}}{T_{\text{surr}}} \\ &= (1000 \text{ kg})(4.18 \text{ kJ/kg}\cdot\text{K}) \ln \frac{295 \text{ K}}{353 \text{ K}} + \frac{500,000 \text{ kJ}}{276 \text{ K}} \\ &= -750 + 1811 = \mathbf{1061 \text{ kJ/K}} \end{aligned}$$

7-229 A room is to be heated by hot water contained in a tank placed in the room. The minimum initial temperature of the water needed to meet the heating requirements of this room for a 24-h period and the entropy generated are to be determined.

Assumptions 1 Water is an incompressible substance with constant specific heats. **2** Air is an ideal gas with constant specific heats. **3** The energy stored in the container itself is negligible relative to the energy stored in water. **4** The room is maintained at 20°C at all times. **5** The hot water is to meet the heating requirements of this room for a 24-h period.

Properties The specific heat of water at room temperature is $c = 4.18 \text{ kJ/kg}\cdot^\circ\text{C}$ (Table A-3).

Analysis Heat loss from the room during a 24-h period is

$$Q_{\text{loss}} = (10,000 \text{ kJ/h})(24 \text{ h}) = 240,000 \text{ kJ}$$

Taking the contents of the room, including the water, as our system, the energy balance can be written as

$$\underbrace{E_{\text{in}} - E_{\text{out}}}_{\substack{\text{Net energy transfer} \\ \text{by heat, work, and mass}}} = \underbrace{\Delta E_{\text{system}}}_{\substack{\text{Change in internal, kinetic,} \\ \text{potential, etc. energies}}} \rightarrow -Q_{\text{out}} = \Delta U = (\Delta U)_{\text{water}} + (\Delta U)_{\text{air}} \quad \phi^0$$

or

$$-Q_{\text{out}} = [mc(T_2 - T_1)]_{\text{water}}$$

Substituting,

$$-240,000 \text{ kJ} = (1500 \text{ kg})(4.18 \text{ kJ/kg}\cdot^\circ\text{C})(20 - T_1)$$

It gives

$$T_1 = \mathbf{58.3^\circ\text{C}}$$

where T_1 is the temperature of the water when it is first brought into the room.

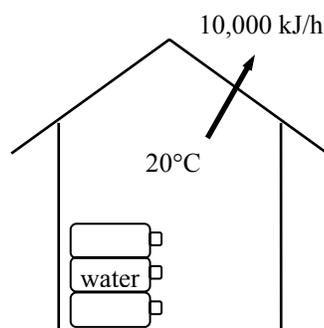

(b) We take the house as the system, which is a closed system. The entropy generated during this process is determined by applying the entropy balance on an *extended system* that includes the house and its immediate surroundings so that the boundary temperature of the extended system is the temperature of the surroundings at all times. The entropy balance for the extended system can be expressed as

$$\underbrace{S_{\text{in}} - S_{\text{out}}}_{\substack{\text{Net entropy transfer} \\ \text{by heat and mass}}} + \underbrace{S_{\text{gen}}}_{\substack{\text{Entropy} \\ \text{generation}}} = \underbrace{\Delta S_{\text{system}}}_{\substack{\text{Change} \\ \text{in entropy}}} \\ -\frac{Q_{\text{out}}}{T_{\text{b,out}}} + S_{\text{gen}} = \Delta S_{\text{water}} + \Delta S_{\text{air}} \quad \phi^0 = \Delta S_{\text{water}}$$

since the state of air in the house (and thus its entropy) remains unchanged. Then the entropy generated during the 24 h period becomes

$$\begin{aligned} S_{\text{gen}} &= \Delta S_{\text{water}} + \frac{Q_{\text{out}}}{T_{\text{b,out}}} = \left(mc \ln \frac{T_2}{T_1} \right)_{\text{water}} + \frac{Q_{\text{out}}}{T_{\text{surr}}} \\ &= (1500 \text{ kg})(4.18 \text{ kJ/kg}\cdot\text{K}) \ln \frac{293 \text{ K}}{331.3 \text{ K}} + \frac{240,000 \text{ kJ}}{278 \text{ K}} \\ &= -770.3 + 863.3 = \mathbf{93.0 \text{ kJ/K}} \end{aligned}$$

7-230 An insulated cylinder is divided into two parts. One side of the cylinder contains N_2 gas and the other side contains He gas at different states. The final equilibrium temperature in the cylinder and the entropy generated are to be determined for the cases of the piston being fixed and moving freely.

Assumptions 1 Both N_2 and He are ideal gases with constant specific heats. **2** The energy stored in the container itself is negligible. **3** The cylinder is well-insulated and thus heat transfer is negligible.

Properties The gas constants and the constant volume specific heats are $R = 0.2968 \text{ kPa}\cdot\text{m}^3/\text{kg}\cdot\text{K}$, $c_v = 0.743 \text{ kJ/kg}\cdot^\circ\text{C}$ and $c_p = 1.039 \text{ kJ/kg}\cdot^\circ\text{C}$ for N_2 , and $R = 2.0769 \text{ kPa}\cdot\text{m}^3/\text{kg}\cdot\text{K}$, $c_v = 3.1156 \text{ kJ/kg}\cdot^\circ\text{C}$, and $c_p = 5.1926 \text{ kJ/kg}\cdot^\circ\text{C}$ for He (Tables A-1 and A-2)

Analysis The mass of each gas in the cylinder is

$$m_{N_2} = \left(\frac{P_1 V_1}{RT_1} \right)_{N_2} = \frac{(500 \text{ kPa})(1 \text{ m}^3)}{(0.2968 \text{ kPa}\cdot\text{m}^3/\text{kg}\cdot\text{K})(353 \text{ K})} = 4.77 \text{ kg}$$

$$m_{He} = \left(\frac{P_1 V_1}{RT_1} \right)_{He} = \frac{(500 \text{ kPa})(1 \text{ m}^3)}{(2.0769 \text{ kPa}\cdot\text{m}^3/\text{kg}\cdot\text{K})(298 \text{ K})} = 0.808 \text{ kg}$$

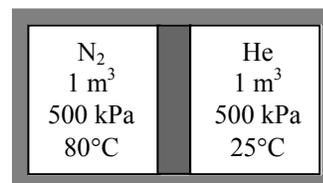

Taking the entire contents of the cylinder as our system, the 1st law relation can be written as

$$\underbrace{E_{in} - E_{out}}_{\substack{\text{Net energy transfer} \\ \text{by heat, work, and mass}}} = \underbrace{\Delta E_{system}}_{\substack{\text{Change in internal, kinetic,} \\ \text{potential, etc. energies}}}$$

$$0 = \Delta U = (\Delta U)_{N_2} + (\Delta U)_{He} \longrightarrow 0 = [mc_v(T_2 - T_1)]_{N_2} + [mc_v(T_2 - T_1)]_{He}$$

Substituting,

$$(4.77 \text{ kg})(0.743 \text{ kJ/kg}\cdot^\circ\text{C})(T_f - 80)^\circ\text{C} + (0.808 \text{ kg})(3.1156 \text{ kJ/kg}\cdot^\circ\text{C})(T_f - 25)^\circ\text{C} = 0$$

It gives

$$T_f = 57.2^\circ\text{C}$$

where T_f is the final equilibrium temperature in the cylinder.

The answer would be the **same** if the piston were not free to move since it would effect only pressure, and not the specific heats.

(b) We take the entire cylinder as our system, which is a closed system. Noting that the cylinder is well-insulated and thus there is no heat transfer, the entropy balance for this closed system can be expressed as

$$\underbrace{S_{in} - S_{out}}_{\substack{\text{Net entropy transfer} \\ \text{by heat and mass}}} + \underbrace{S_{gen}}_{\substack{\text{Entropy} \\ \text{generation}}} = \underbrace{\Delta S_{system}}_{\substack{\text{Change} \\ \text{in entropy}}}$$

$$0 + S_{gen} = \Delta S_{N_2} + \Delta S_{He}$$

But first we determine the final pressure in the cylinder:

$$N_{total} = N_{N_2} + N_{He} = \left(\frac{m}{M} \right)_{N_2} + \left(\frac{m}{M} \right)_{He} = \frac{4.77 \text{ kg}}{28 \text{ kg/kmol}} + \frac{0.808 \text{ kg}}{4 \text{ kg/kmol}} = 0.372 \text{ kmol}$$

$$P_2 = \frac{N_{total} R_u T}{V_{total}} = \frac{(0.372 \text{ kmol})(8.314 \text{ kPa}\cdot\text{m}^3/\text{kmol}\cdot\text{K})(330.2 \text{ K})}{2 \text{ m}^3} = 510.6 \text{ kPa}$$

Then,

$$\begin{aligned}
\Delta S_{N_2} &= m \left(c_p \ln \frac{T_2}{T_1} - R \ln \frac{P_2}{P_1} \right)_{N_2} \\
&= (4.77 \text{ kg}) \left[(1.039 \text{ kJ/kg} \cdot \text{K}) \ln \frac{330.2 \text{ K}}{353 \text{ K}} - (0.2968 \text{ kJ/kg} \cdot \text{K}) \ln \frac{510.6 \text{ kPa}}{500 \text{ kPa}} \right] \\
&= -0.361 \text{ kJ/K} \\
\Delta S_{He} &= m \left(c_p \ln \frac{T_2}{T_1} - R \ln \frac{P_2}{P_1} \right)_{He} \\
&= (0.808 \text{ kg}) \left[(5.1926 \text{ kJ/kg} \cdot \text{K}) \ln \frac{330.2 \text{ K}}{298 \text{ K}} - (2.0769 \text{ kJ/kg} \cdot \text{K}) \ln \frac{510.6 \text{ kPa}}{500 \text{ kPa}} \right] \\
&= 0.395 \text{ kJ/K} \\
S_{\text{gen}} &= \Delta S_{N_2} + \Delta S_{He} = -0.361 + 0.395 = \mathbf{0.034 \text{ kJ/K}}
\end{aligned}$$

If the piston were not free to move, we would still have $T_2 = 330.2 \text{ K}$ but the volume of each gas would remain constant in this case:

$$\begin{aligned}
\Delta S_{N_2} &= m \left(c_v \ln \frac{T_2}{T_1} - R \ln \frac{V_2}{V_1} \right)_{N_2} = (4.77 \text{ kg}) (0.743 \text{ kJ/kg} \cdot \text{K}) \ln \frac{330.2 \text{ K}}{353 \text{ K}} = -0.237 \text{ kJ/K} \\
\Delta S_{He} &= m \left(c_v \ln \frac{T_2}{T_1} - R \ln \frac{V_2}{V_1} \right)_{He} = (0.808 \text{ kg}) (3.1156 \text{ kJ/kg} \cdot \text{K}) \ln \frac{330.2 \text{ K}}{298 \text{ K}} = 0.258 \text{ kJ/K} \\
S_{\text{gen}} &= \Delta S_{N_2} + \Delta S_{He} = -0.237 + 0.258 = \mathbf{0.021 \text{ kJ/K}}
\end{aligned}$$

7-231 EES Problem 7-230 is reconsidered. The results for constant specific heats to those obtained using variable specific heats are to be compared using built-in EES or other functions.

Analysis The problem is solved using EES, and the results are given below.

"Knowns:"

$R_u = 8.314$ [kJ/kmol-K]
 $V_{N2[1]} = 1$ [m³]
 $Cv_{N2} = 0.743$ [kJ/kg-K] "From Table A-2(a) at 27C"
 $R_{N2} = 0.2968$ [kJ/kg-K] "From Table A-2(a)"
 $T_{N2[1]} = 80$ [C]
 $P_{N2[1]} = 500$ [kPa]
 $Cp_{N2} = R_{N2} + Cv_{N2}$
 $V_{He[1]} = 1$ [m³]
 $Cv_{He} = 3.1156$ [kJ/kg-K] "From Table A-2(a) at 27C"
 $T_{He[1]} = 25$ [C]
 $P_{He[1]} = 500$ [kPa]
 $R_{He} = 2.0769$ [kJ/kg-K] "From Table A-2(a)"
 $Cp_{He} = R_{He} + Cv_{He}$

"Solution:"

"mass calculations:"

$P_{N2[1]} * V_{N2[1]} = m_{N2} * R_{N2} * (T_{N2[1]} + 273)$
 $P_{He[1]} * V_{He[1]} = m_{He} * R_{He} * (T_{He[1]} + 273)$

"The entire cylinder is considered to be a closed system, allowing the piston to move."

"Conservation of Energy for the closed system:"

" $E_{in} - E_{out} = \Delta E$, we neglect ΔKE and ΔPE for the cylinder."

$E_{in} - E_{out} = \Delta E$

$E_{in} = 0$ [kJ]

$E_{out} = 0$ [kJ]

"At the final equilibrium state, N2 and He will have a common temperature."

$\Delta E = m_{N2} * Cv_{N2} * (T_2 - T_{N2[1]}) + m_{He} * Cv_{He} * (T_2 - T_{He[1]})$

"Total volume of gases:"

$V_{total} = V_{N2[1]} + V_{He[1]}$

$MM_{He} = 4$ [kg/kmol]

$MM_{N2} = 28$ [kg/kmol]

$N_{total} = m_{He} / MM_{He} + m_{N2} / MM_{N2}$

"Final pressure at equilibrium:"

"Allowing the piston to move, the pressure on both sides is the same, P_2 is:"

$P_2 * V_{total} = N_{total} * R_u * (T_2 + 273)$

$S_{gen_PistonMoving} = \Delta S_{He_PM} + \Delta S_{N2_PM}$

$\Delta S_{He_PM} = m_{He} * (Cp_{He} * \ln((T_2 + 273) / (T_{He[1]} + 273)) - R_{He} * \ln(P_2 / P_{He[1]}))$

$\Delta S_{N2_PM} = m_{N2} * (Cp_{N2} * \ln((T_2 + 273) / (T_{N2[1]} + 273)) - R_{N2} * \ln(P_2 / P_{N2[1]}))$

"The final temperature of the system when the piston does not move will be the same as when it does move. The volume of the gases remain constant and the entropy changes are given by:"

$S_{gen_PistNotMoving} = \Delta S_{He_PNM} + \Delta S_{N2_PNM}$

$\Delta S_{He_PNM} = m_{He} * (Cv_{He} * \ln((T_2 + 273) / (T_{He[1]} + 273)))$

$\Delta S_{N2_PNM} = m_{N2} * (Cv_{N2} * \ln((T_2 + 273) / (T_{N2[1]} + 273)))$

"The following uses the EES functions for the nitrogen. Since helium is monatomic, we use the constant specific heat approach to find its property changes."

$$E_{in} - E_{out} = \text{DELTA}E_{VP}$$

$$\text{DELTA}E_{VP} = m_{N2} * (\text{INTENERGY}(N2, T=T_{2_VP}) - \text{INTENERGY}(N2, T=T_{N2[1]})) + m_{He} * C_{v_He} * (T_{2_VP} - T_{He[1]})$$

"Final Pressure for moving piston:"

$$P_{2_VP} * V_{total} = N_{total} * R_u * (T_{2_VP} + 273)$$

$$S_{gen_PistMoving_VP} = \text{DELTA}S_{He_PM_VP} + \text{DELTA}S_{N2_PM_VP}$$

$$\text{DELTA}S_{N2_PM_VP} = m_{N2} * (\text{ENTROPY}(N2, T=T_{2_VP}, P=P_{2_VP}) - \text{ENTROPY}(N2, T=T_{N2[1]}, P=P_{N2[1]}))$$

$$\text{DELTA}S_{He_PM_VP} = m_{He} * (C_p_{He} * \ln((T_{2_VP} + 273)/(T_{He[1]} + 273)) - R_{He} * \ln(P_{2_VP}/P_{He[1]}))$$

"Final N2 Pressure for piston not moving."

$$P_{2_N2_VP} * V_{N2[1]} = m_{N2} * R_{N2} * (T_{2_VP} + 273)$$

$$S_{gen_PistNotMoving_VP} = \text{DELTA}S_{He_PNM_VP} + \text{DELTA}S_{N2_PNM_VP}$$

$$\text{DELTA}S_{N2_PNM_VP} = m_{N2} * (\text{ENTROPY}(N2, T=T_{2_VP}, P=P_{2_N2_VP}) - \text{ENTROPY}(N2, T=T_{N2[1]}, P=P_{N2[1]}))$$

$$\text{DELTA}S_{He_PNM_VP} = m_{He} * (C_v_{He} * \ln((T_{2_VP} + 273)/(T_{He[1]} + 273)))$$

SOLUTION

Cp_He=5.193 [kJ/kg-K]	P_2=511.1 [kPa]
Cp_N2=1.04 [kJ/kg-K]	P_2_N2_VP=467.7
Cv_He=3.116 [kJ/kg-K]	P_2_VP=511.2
Cv_N2=0.743 [kJ/kg-K]	P_He[1]=500 [kPa]
DELTAE=0 [kJ]	P_N2[1]=500 [kPa]
DELTAE_VP=0 [kJ]	R_He=2.077 [kJ/kg-K]
DELTA S_He_PM=0.3931 [kJ/K]	R_N2=0.2968 [kJ/kg-K]
DELTA S_He_PM_VP=0.3931 [kJ/K]	R_u=8.314 [kJ/kmol-K]
DELTA S_He_PNM=0.258 [kJ/K]	S_gen_PistMoving_VP=0.02993 [kJ/K]
DELTA S_He_PNM_VP=0.2583 [kJ/K]	S_gen_PistNotMoving=0.02089 [kJ/K]
DELTA S_N2_PM=-0.363 [kJ/K]	S_gen_PistNotMoving_VP=0.02106 [kJ/K]
DELTA S_N2_PM_VP=-0.3631 [kJ/K]	S_gen_PistonMoving=0.03004 [kJ/K]
DELTA S_N2_PNM=-0.2371 [kJ/K]	T_2=57.17 [C]
DELTA S_N2_PNM_VP=-0.2372 [kJ/K]	T_2_VP=57.2 [C]
E_in=0 [kJ]	T_He[1]=25 [C]
E_out=0 [kJ]	T_N2[1]=80 [C]
MM_He=4 [kg/kmol]	V_He[1]=1 [m^3]
MM_N2=28 [kg/kmol]	V_N2[1]=1 [m^3]
m_He=0.8079 [kg]	V_total=2 [m^3]
m_N2=4.772 [kg]	
N_total=0.3724 [kmol]	

7-232 An insulated cylinder is divided into two parts. One side of the cylinder contains N₂ gas and the other side contains He gas at different states. The final equilibrium temperature in the cylinder and the entropy generated are to be determined for the cases of the piston being fixed and moving freely.

Assumptions 1 Both N₂ and He are ideal gases with constant specific heats. **2** The energy stored in the container itself, except the piston, is negligible. **3** The cylinder is well-insulated and thus heat transfer is negligible. **4** Initially, the piston is at the average temperature of the two gases.

Properties The gas constants and the constant volume specific heats are $R = 0.2968 \text{ kPa}\cdot\text{m}^3/\text{kg}\cdot\text{K}$, $c_v = 0.743 \text{ kJ/kg}\cdot^\circ\text{C}$ and $c_p = 1.039 \text{ kJ/kg}\cdot^\circ\text{C}$ for N₂, and $R = 2.0769 \text{ kPa}\cdot\text{m}^3/\text{kg}\cdot\text{K}$, $c_v = 3.1156 \text{ kJ/kg}\cdot^\circ\text{C}$, and $c_p = 5.1926 \text{ kJ/kg}\cdot^\circ\text{C}$ for He (Tables A-1 and A-2). The specific heat of the copper at room temperature is $c = 0.386 \text{ kJ/kg}\cdot^\circ\text{C}$ (Table A-3).

Analysis The mass of each gas in the cylinder is

$$m_{\text{N}_2} = \left(\frac{P_1 V_1}{RT_1} \right)_{\text{N}_2} = \frac{(500 \text{ kPa})(1 \text{ m}^3)}{(0.2968 \text{ kPa}\cdot\text{m}^3/\text{kg}\cdot\text{K})(353 \text{ K})} = 4.77 \text{ kg}$$

$$m_{\text{He}} = \left(\frac{P_1 V_1}{RT_1} \right)_{\text{He}} = \frac{(500 \text{ kPa})(1 \text{ m}^3)}{(2.0769 \text{ kPa}\cdot\text{m}^3/\text{kg}\cdot\text{K})(298 \text{ K})} = 0.808 \text{ kg}$$

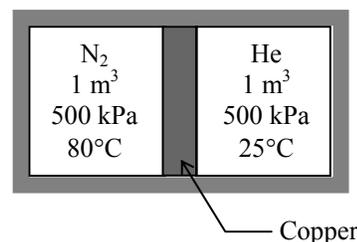

Taking the entire contents of the cylinder as our system, the 1st law relation can be written as

$$\underbrace{E_{\text{in}} - E_{\text{out}}}_{\substack{\text{Net energy transfer} \\ \text{by heat, work, and mass}}} = \underbrace{\Delta E_{\text{system}}}_{\substack{\text{Change in internal, kinetic,} \\ \text{potential, etc. energies}}}$$

$$0 = \Delta U = (\Delta U)_{\text{N}_2} + (\Delta U)_{\text{He}} + (\Delta U)_{\text{Cu}}$$

$$0 = [mc_v(T_2 - T_1)]_{\text{N}_2} + [mc_v(T_2 - T_1)]_{\text{He}} + [mc(T_2 - T_1)]_{\text{Cu}}$$

where

$$T_{1, \text{Cu}} = (80 + 25) / 2 = 52.5^\circ\text{C}$$

Substituting,

$$(4.77 \text{ kg})(0.743 \text{ kJ/kg}\cdot^\circ\text{C})(T_f - 80)^\circ\text{C} + (0.808 \text{ kg})(3.1156 \text{ kJ/kg}\cdot^\circ\text{C})(T_f - 25)^\circ\text{C} \\ + (5.0 \text{ kg})(0.386 \text{ kJ/kg}\cdot^\circ\text{C})(T_f - 52.5)^\circ\text{C} = 0$$

It gives

$$T_f = \mathbf{56.0^\circ\text{C}}$$

where T_f is the final equilibrium temperature in the cylinder.

The answer would be the **same** if the piston were not free to move since it would effect only pressure, and not the specific heats.

(b) We take the entire cylinder as our system, which is a closed system. Noting that the cylinder is well-insulated and thus there is no heat transfer, the entropy balance for this closed system can be expressed as

$$\underbrace{S_{\text{in}} - S_{\text{out}}}_{\substack{\text{Net entropy transfer} \\ \text{by heat and mass}}} + \underbrace{S_{\text{gen}}}_{\substack{\text{Entropy} \\ \text{generation}}} = \underbrace{\Delta S_{\text{system}}}_{\substack{\text{Change} \\ \text{in entropy}}}$$

$$0 + S_{\text{gen}} = \Delta S_{\text{N}_2} + \Delta S_{\text{He}} + \Delta S_{\text{piston}}$$

But first we determine the final pressure in the cylinder:

$$N_{\text{total}} = N_{\text{N}_2} + N_{\text{He}} = \left(\frac{m}{M}\right)_{\text{N}_2} + \left(\frac{m}{M}\right)_{\text{He}} = \frac{4.77 \text{ kg}}{28 \text{ kg/kmol}} + \frac{0.808 \text{ kg}}{4 \text{ kg/kmol}} = 0.372 \text{ kmol}$$

$$P_2 = \frac{N_{\text{total}} R_u T}{V_{\text{total}}} = \frac{(0.372 \text{ kmol})(8.314 \text{ kPa} \cdot \text{m}^3/\text{kmol} \cdot \text{K})(329 \text{ K})}{2 \text{ m}^3} = 508.8 \text{ kPa}$$

Then,

$$\begin{aligned} \Delta S_{\text{N}_2} &= m \left(c_p \ln \frac{T_2}{T_1} - R \ln \frac{P_2}{P_1} \right)_{\text{N}_2} \\ &= (4.77 \text{ kg}) \left[(1.039 \text{ kJ/kg} \cdot \text{K}) \ln \frac{329 \text{ K}}{353 \text{ K}} - (0.2968 \text{ kJ/kg} \cdot \text{K}) \ln \frac{508.8 \text{ kPa}}{500 \text{ kPa}} \right] \\ &= -0.374 \text{ kJ/K} \\ \Delta S_{\text{He}} &= m \left(c_p \ln \frac{T_2}{T_1} - R \ln \frac{P_2}{P_1} \right)_{\text{He}} \\ &= (0.808 \text{ kg}) \left[(5.1926 \text{ kJ/kg} \cdot \text{K}) \ln \frac{329 \text{ K}}{298 \text{ K}} - (2.0769 \text{ kJ/kg} \cdot \text{K}) \ln \frac{508.8 \text{ kPa}}{500 \text{ kPa}} \right] \\ &= 0.386 \text{ kJ/K} \\ \Delta S_{\text{piston}} &= \left(mc \ln \frac{T_2}{T_1} \right)_{\text{piston}} = (5 \text{ kg}) (0.386 \text{ kJ/kg} \cdot \text{K}) \ln \frac{329 \text{ K}}{325.5 \text{ K}} = 0.021 \text{ kJ/K} \\ S_{\text{gen}} &= \Delta S_{\text{N}_2} + \Delta S_{\text{He}} + \Delta S_{\text{piston}} = -0.374 + 0.386 + 0.021 = \mathbf{0.033 \text{ kJ/K}} \end{aligned}$$

If the piston were not free to move, we would still have $T_2 = 329 \text{ K}$ but the volume of each gas would remain constant in this case:

$$\begin{aligned} \Delta S_{\text{N}_2} &= m \left(c_v \ln \frac{T_2}{T_1} - R \ln \frac{V_2}{V_1} \right)_{\text{N}_2}^{\phi_0} = (4.77 \text{ kg}) (0.743 \text{ kJ/kg} \cdot \text{K}) \ln \frac{329 \text{ K}}{353 \text{ K}} = -0.250 \text{ kJ/K} \\ \Delta S_{\text{He}} &= m \left(c_v \ln \frac{T_2}{T_1} - R \ln \frac{V_2}{V_1} \right)_{\text{He}}^{\phi_0} = (0.808 \text{ kg}) (3.1156 \text{ kJ/kg} \cdot \text{K}) \ln \frac{329 \text{ K}}{298 \text{ K}} = 0.249 \text{ kJ/K} \\ S_{\text{gen}} &= \Delta S_{\text{N}_2} + \Delta S_{\text{He}} + \Delta S_{\text{piston}} = -0.250 + 0.249 + 0.021 = \mathbf{0.020 \text{ kJ/K}} \end{aligned}$$

7-233 An insulated rigid tank equipped with an electric heater initially contains pressurized air. A valve is opened, and air is allowed to escape at constant temperature until the pressure inside drops to a specified value. The amount of electrical work done during this process and the total entropy change are to be determined.

Assumptions 1 This is an unsteady process since the conditions within the device are changing during the process, but it can be analyzed as a uniform-flow process since the exit temperature (and enthalpy) of air remains constant. **2** Kinetic and potential energies are negligible. **3** The tank is insulated and thus heat transfer is negligible. **4** Air is an ideal gas with variable specific heats.

Properties The gas constant is $R = 0.287 \text{ kPa}\cdot\text{m}^3/\text{kg}\cdot\text{K}$ (Table A-1). The properties of air are (Table A-17)

$$T_e = 330 \text{ K} \longrightarrow h_e = 330.34 \text{ kJ/kg}$$

$$T_1 = 330 \text{ K} \longrightarrow u_1 = 235.61 \text{ kJ/kg}$$

$$T_2 = 330 \text{ K} \longrightarrow u_2 = 235.61 \text{ kJ/kg}$$

Analysis We take the tank as the system, which is a control volume since mass crosses the boundary. Noting that the microscopic energies of flowing and nonflowing fluids are represented by enthalpy h and internal energy u , respectively, the mass and energy balances for this uniform-flow system can be expressed as

Mass balance:

$$m_{\text{in}} - m_{\text{out}} = \Delta m_{\text{system}} \rightarrow m_e = m_1 - m_2$$

Energy balance:

$$\underbrace{E_{\text{in}} - E_{\text{out}}}_{\substack{\text{Net energy transfer} \\ \text{by heat, work, and mass}}} = \underbrace{\Delta E_{\text{system}}}_{\substack{\text{Change in internal, kinetic,} \\ \text{potential, etc. energies}}}$$

$$W_{e,\text{in}} - m_e h_e = m_2 u_2 - m_1 u_1 \quad (\text{since } Q \cong \text{ke} \cong \text{pe} \cong 0)$$

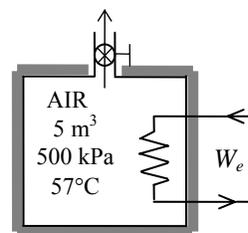

The initial and the final masses of air in the tank are

$$m_1 = \frac{P_1 V}{RT_1} = \frac{(500 \text{ kPa})(5 \text{ m}^3)}{(0.287 \text{ kPa}\cdot\text{m}^3/\text{kg}\cdot\text{K})(330 \text{ K})} = 26.40 \text{ kg}$$

$$m_2 = \frac{P_2 V}{RT_2} = \frac{(200 \text{ kPa})(5 \text{ m}^3)}{(0.287 \text{ kPa}\cdot\text{m}^3/\text{kg}\cdot\text{K})(330 \text{ K})} = 10.56 \text{ kg}$$

Then from the mass and energy balances,

$$m_e = m_1 - m_2 = 26.40 - 10.56 = 15.84 \text{ kg}$$

$$W_{e,\text{in}} = m_e h_e + m_2 u_2 - m_1 u_1$$

$$= (15.84 \text{ kg})(330.34 \text{ kJ/kg}) + (10.56 \text{ kg})(235.61 \text{ kJ/kg}) - (26.40 \text{ kg})(235.61 \text{ kJ/kg}) = \mathbf{1501 \text{ kJ}}$$

(b) The total entropy change, or the total entropy generation within the tank boundaries is determined from an entropy balance on the tank expressed as

$$\underbrace{S_{\text{in}} - S_{\text{out}}}_{\substack{\text{Net entropy transfer} \\ \text{by heat and mass}}} + \underbrace{S_{\text{gen}}}_{\substack{\text{Entropy} \\ \text{generation}}} = \underbrace{\Delta S_{\text{system}}}_{\substack{\text{Change} \\ \text{in entropy}}}$$

$$-m_e s_e + S_{\text{gen}} = \Delta S_{\text{tank}}$$

or,

$$S_{\text{gen}} = m_e s_e + \Delta S_{\text{tank}} = m_e s_e + (m_2 s_2 - m_1 s_1) \\ = (m_1 - m_2) s_e + (m_2 s_2 - m_1 s_1) = m_2 (s_2 - s_e) - m_1 (s_1 - s_e)$$

Assuming a constant average pressure of $(500 + 200)/2 = 350$ kPa for the exit stream, the entropy changes are determined to be

$$s_2 - s_e = c_p \ln \frac{T_2}{T_e} - R \ln \frac{P_2}{P_e} = -R \ln \frac{P_2}{P_e} = -(0.287 \text{ kJ/kg} \cdot \text{K}) \ln \frac{200 \text{ kPa}}{350 \text{ kPa}} = 0.1606 \text{ kJ/kg} \cdot \text{K}$$

$$s_1 - s_e = c_p \ln \frac{T_1}{T_e} - R \ln \frac{P_1}{P_e} = -R \ln \frac{P_1}{P_e} = -(0.287 \text{ kJ/kg} \cdot \text{K}) \ln \frac{500 \text{ kPa}}{350 \text{ kPa}} = -0.1024 \text{ kJ/kg} \cdot \text{K}$$

Therefore, the total entropy generated within the tank during this process is

$$S_{\text{gen}} = (10.56 \text{ kg})(0.1606 \text{ kJ/kg} \cdot \text{K}) - (26.40 \text{ kg})(-0.1024 \text{ kJ/kg} \cdot \text{K}) = \mathbf{4.40 \text{ kJ/K}}$$

7-234 An insulated cylinder initially contains a saturated liquid-vapor mixture of water at a specified temperature. The entire vapor in the cylinder is to be condensed isothermally by adding ice inside the cylinder. The amount of ice added and the entropy generation are to be determined.

Assumptions 1 Thermal properties of the ice are constant. **2** The cylinder is well-insulated and thus heat transfer is negligible. **3** There is no stirring by hand or a mechanical device (it will add energy).

Properties The specific heat of ice at about 0°C is $c = 2.11 \text{ kJ/kg}\cdot\text{°C}$ (Table A-3). The melting temperature and the heat of fusion of ice at 1 atm are 0°C and 333.7 kJ/kg.

Analysis (a) We take the contents of the cylinder (ice and saturated water) as our system, which is a closed system. Noting that the temperature and thus the pressure remains constant during this phase change process and thus $W_b + \Delta U = \Delta H$, the energy balance for this system can be written as

$$\underbrace{E_{in} - E_{out}}_{\substack{\text{Net energy transfer} \\ \text{by heat, work, and mass}}} = \underbrace{\Delta E_{\text{system}}}_{\substack{\text{Change in internal, kinetic,} \\ \text{potential, etc. energies}}}$$

$$W_{b,in} = \Delta U$$

$$\Delta H = 0$$

$$\Delta H_{\text{ice}} + \Delta H_{\text{water}} = 0$$

or

$$[mc(0^\circ\text{C} - T_1)_{\text{solid}} + mh_{if} + mc(T_2 - 0^\circ\text{C})_{\text{liquid}}]_{\text{ice}} + [m(h_2 - h_1)]_{\text{water}} = 0$$

The properties of water at 100°C are (Table A-4)

$$\nu_f = 0.001043, \quad \nu_g = 1.6720 \text{ m}^3/\text{kg}$$

$$h_f = 419.17, \quad h_{fg} = 2256.4 \text{ kJ/kg}$$

$$s_f = 1.3072, \quad s_{fg} = 6.0490 \text{ kJ/kg}\cdot\text{K}$$

$$\nu_1 = \nu_f + x_1\nu_{fg} = 0.001043 + (0.1)(1.6720 - 0.001043) = 0.16814 \text{ m}^3/\text{kg}$$

$$h_1 = h_f + x_1h_{fg} = 419.17 + (0.1)(2256.4) = 644.81 \text{ kJ/kg}$$

$$s_1 = s_f + x_1s_{fg} = 1.3072 + (0.1)(6.0470) = 1.9119 \text{ kJ/kg}\cdot\text{K}$$

$$h_2 = h_{f@100^\circ\text{C}} = 419.17 \text{ kJ/kg}$$

$$s_2 = s_{f@100^\circ\text{C}} = 1.3072 \text{ kJ/kg}\cdot\text{K}$$

$$m_{\text{steam}} = \frac{\nu_1}{\nu_1} = \frac{0.02 \text{ m}^3}{0.16814 \text{ m}^3/\text{kg}} = 0.119 \text{ kg}$$

Noting that $T_{1,\text{ice}} = -18^\circ\text{C}$ and $T_2 = 100^\circ\text{C}$ and substituting gives

$$m\{(2.11 \text{ kJ/kg}\cdot\text{K})[0 - (-18)] + 333.7 \text{ kJ/kg} + (4.18 \text{ kJ/kg}\cdot\text{°C})(100 - 0)^\circ\text{C}\} \\ + (0.119 \text{ kg})(419.17 - 644.81) \text{ kJ/kg} = 0$$

$$m = 0.034 \text{ kg} = \mathbf{34.0 \text{ g ice}}$$

(b) We take the ice and the steam as our system, which is a closed system. Considering that the tank is well-insulated and thus there is no heat transfer, the entropy balance for this closed system can be expressed as

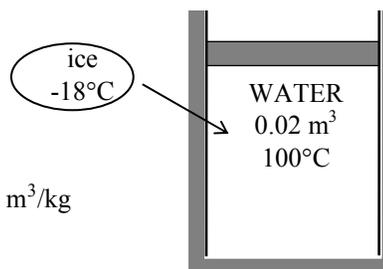

$$\underbrace{S_{\text{in}} - S_{\text{out}}}_{\substack{\text{Net entropy transfer} \\ \text{by heat and mass}}} + \underbrace{S_{\text{gen}}}_{\substack{\text{Entropy} \\ \text{generation}}} = \underbrace{\Delta S_{\text{system}}}_{\substack{\text{Change} \\ \text{in entropy}}} \\ 0 + S_{\text{gen}} = \Delta S_{\text{ice}} + \Delta S_{\text{steam}}$$

$$\Delta S_{\text{steam}} = m(s_2 - s_1) = (0.119 \text{ kg})(1.3072 - 1.9119) \text{ kJ/kg} \cdot \text{K} = -0.0719 \text{ kJ/K}$$

$$\begin{aligned} \Delta S_{\text{ice}} &= (\Delta S_{\text{solid}} + \Delta S_{\text{melting}} + \Delta S_{\text{liquid}})_{\text{ice}} = \left(\left(mc \ln \frac{T_{\text{melting}}}{T_1} \right)_{\text{solid}} + \frac{mh_{\text{if}}}{T_{\text{melting}}} + \left(mc \ln \frac{T_2}{T_1} \right)_{\text{liquid}} \right)_{\text{ice}} \\ &= (0.034 \text{ kg}) \left((2.11 \text{ kJ/kg} \cdot \text{K}) \ln \frac{273.15 \text{ K}}{255.15 \text{ K}} + \frac{333.7 \text{ kJ/kg}}{273.15 \text{ K}} + (4.18 \text{ kJ/kg} \cdot \text{K}) \ln \frac{373.15 \text{ K}}{273.15 \text{ K}} \right) = 0.0907 \text{ kJ/K} \end{aligned}$$

Then,

$$S_{\text{gen}} = \Delta S_{\text{steam}} + \Delta S_{\text{ice}} = -0.0719 + 0.0907 = \mathbf{0.0188 \text{ kJ/K}}$$

7-235 An evacuated bottle is surrounded by atmospheric air. A valve is opened, and air is allowed to fill the bottle. The amount of heat transfer through the wall of the bottle when thermal and mechanical equilibrium is established and the amount of entropy generated are to be determined.

Assumptions 1 This is an unsteady process since the conditions within the device are changing during the process, but it can be analyzed as a uniform-flow process since the state of fluid at the inlet remains constant. **2** Air is an ideal gas. **3** Kinetic and potential energies are negligible. **4** There are no work interactions involved. **5** The direction of heat transfer is to the air in the bottle (will be verified).

Properties The gas constant of air is $0.287 \text{ kPa}\cdot\text{m}^3/\text{kg}\cdot\text{K}$ (Table A-1).

Analysis We take the bottle as the system, which is a control volume since mass crosses the boundary. Noting that the microscopic energies of flowing and nonflowing fluids are represented by enthalpy h and internal energy u , respectively, the mass and energy balances for this uniform-flow system can be expressed as

$$\text{Mass balance: } m_{\text{in}} - m_{\text{out}} = \Delta m_{\text{system}} \rightarrow m_i = m_2 \quad (\text{since } m_{\text{out}} = m_{\text{initial}} = 0)$$

Energy balance:

$$\underbrace{E_{\text{in}} - E_{\text{out}}}_{\substack{\text{Net energy transfer} \\ \text{by heat, work, and mass}}} = \underbrace{\Delta E_{\text{system}}}_{\substack{\text{Change in internal, kinetic,} \\ \text{potential, etc. energies}}}$$

$$Q_{\text{in}} + m_i h_i = m_2 u_2 \quad (\text{since } W \cong E_{\text{out}} = E_{\text{initial}} = \text{ke} \cong \text{pe} \cong 0)$$

Combining the two balances:

$$Q_{\text{in}} = m_2(u_2 - h_i)$$

where

$$m_2 = \frac{P_2 V}{RT_2} = \frac{(100 \text{ kPa})(0.005 \text{ m}^3)}{(0.287 \text{ kPa}\cdot\text{m}^3/\text{kg}\cdot\text{K})(290 \text{ K})} = 0.0060 \text{ kg}$$

$$T_i = T_2 = 290 \text{ K} \xrightarrow{\text{Table A-17}} \begin{aligned} h_i &= 290.16 \text{ kJ/kg} \\ u_2 &= 206.91 \text{ kJ/kg} \end{aligned}$$

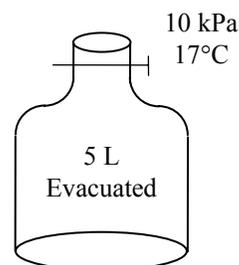

Substituting,

$$Q_{\text{in}} = (0.0060 \text{ kg})(206.91 - 290.16) \text{ kJ/kg} = -0.5 \text{ kJ} \rightarrow Q_{\text{out}} = \mathbf{0.5 \text{ kJ}}$$

Note that the negative sign for heat transfer indicates that the assumed direction is wrong. Therefore, we reverse the direction.

The entropy generated during this process is determined by applying the entropy balance on an *extended system* that includes the bottle and its immediate surroundings so that the boundary temperature of the extended system is the temperature of the surroundings at all times. The entropy balance for it can be expressed as

$$\underbrace{S_{\text{in}} - S_{\text{out}}}_{\substack{\text{Net entropy transfer} \\ \text{by heat and mass}}} + \underbrace{S_{\text{gen}}}_{\substack{\text{Entropy} \\ \text{generation}}} = \underbrace{\Delta S_{\text{system}}}_{\substack{\text{Change} \\ \text{in entropy}}}$$

$$m_i s_i - \frac{Q_{\text{out}}}{T_{\text{b,in}}} + S_{\text{gen}} = \Delta S_{\text{tank}} = m_2 s_2 - m_1 s_1^{\phi 0} = m_2 s_2$$

Therefore, the total entropy generated during this process is

$$S_{\text{gen}} = -m_i s_i + m_2 s_2 + \frac{Q_{\text{out}}}{T_{\text{b,out}}} = m_2 (s_2 - s_i)^{\phi 0} + \frac{Q_{\text{out}}}{T_{\text{b,out}}} = \frac{Q_{\text{out}}}{T_{\text{surr}}} = \frac{0.5 \text{ kJ}}{290 \text{ K}} = \mathbf{0.0017 \text{ kJ/K}}$$

7-236 Water is heated from 16°C to 43°C by an electric resistance heater placed in the water pipe as it flows through a showerhead steadily at a rate of 10 L/min. The electric power input to the heater and the rate of entropy generation are to be determined. The reduction in power input and entropy generation as a result of installing a 50% efficient regenerator are also to be determined.

Assumptions 1 This is a steady-flow process since there is no change with time at any point within the system and thus $\Delta m_{CV} = 0$ and $\Delta E_{CV} = 0$. **2** Water is an incompressible substance with constant specific heats. **3** The kinetic and potential energy changes are negligible, $\Delta ke \cong \Delta pe \cong 0$. **4** Heat losses from the pipe are negligible.

Properties The density of water is given to be $\rho = 1$ kg/L. The specific heat of water at room temperature is $c = 4.18$ kJ/kg·°C (Table A-3).

Analysis (a) We take the pipe as the system. This is a *control volume* since mass crosses the system boundary during the process. We observe that there is only one inlet and one exit and thus $\dot{m}_1 = \dot{m}_2 = \dot{m}$. Then the energy balance for this steady-flow system can be expressed in the rate form as

$$\underbrace{\dot{E}_{in} - \dot{E}_{out}}_{\text{Rate of net energy transfer by heat, work, and mass}} = \underbrace{\Delta \dot{E}_{system}^{\neq 0} \text{ (steady)}}_{\text{Rate of change in internal, kinetic, potential, etc. energies}} = 0 \rightarrow \dot{E}_{in} = \dot{E}_{out}$$

$$\dot{W}_{e,in} + \dot{m}h_1 = \dot{m}h_2 \quad (\text{since } \Delta ke \cong \Delta pe \cong 0)$$

$$\dot{W}_{e,in} = \dot{m}(h_2 - h_1) = \dot{m}c(T_2 - T_1)$$

where

$$\dot{m} = \rho \dot{V} = (1 \text{ kg/L})(10 \text{ L/min}) = 10 \text{ kg/min}$$

Substituting,

$$\dot{W}_{e,in} = (10/60 \text{ kg/s})(4.18 \text{ kJ/kg} \cdot \text{°C})(43 - 16) \text{°C} = \mathbf{18.8 \text{ kW}}$$

The rate of entropy generation in the heating section during this process is determined by applying the entropy balance on the heating section. Noting that this is a steady-flow process and heat transfer from the heating section is negligible,

$$\underbrace{\dot{S}_{in} - \dot{S}_{out}}_{\text{Rate of net entropy transfer by heat and mass}} + \underbrace{\dot{S}_{gen}}_{\text{Rate of entropy generation}} = \underbrace{\Delta \dot{S}_{system}^{\neq 0}}_{\text{Rate of change of entropy}} = 0$$

$$\dot{m}s_1 - \dot{m}s_2 + \dot{S}_{gen} = 0 \rightarrow \dot{S}_{gen} = \dot{m}(s_2 - s_1)$$

Noting that water is an incompressible substance and substituting,

$$\dot{S}_{gen} = \dot{m}c \ln \frac{T_2}{T_1} = (10/60 \text{ kg/s})(4.18 \text{ kJ/kg} \cdot \text{K}) \ln \frac{316 \text{ K}}{289 \text{ K}} = \mathbf{0.0622 \text{ kJ/K}}$$

(b) The energy recovered by the heat exchanger is

$$\dot{Q}_{saved} = \varepsilon \dot{Q}_{max} = \varepsilon \dot{m}c(T_{max} - T_{min}) = 0.5(10/60 \text{ kg/s})(4.18 \text{ kJ/kg} \cdot \text{°C})(39 - 16) \text{°C} = 8.0 \text{ kJ/s} = 8.0 \text{ kW}$$

Therefore, 8.0 kW less energy is needed in this case, and the required electric power in this case reduces to

$$\dot{W}_{in,new} = \dot{W}_{in,old} - \dot{Q}_{saved} = 18.8 - 8.0 = \mathbf{10.8 \text{ kW}}$$

Taking the cold water stream in the heat exchanger as our control volume (a steady-flow system), the temperature at which the cold water leaves the heat exchanger and enters the electric resistance heating section is determined from

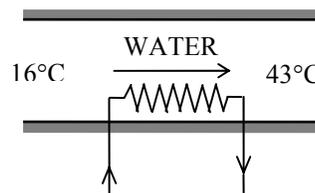

$$\dot{Q} = \dot{m}c(T_{c,\text{out}} - T_{c,\text{in}})$$

Substituting,

$$8 \text{ kJ/s} = (10/60 \text{ kg/s})(4.18 \text{ kJ/kg}\cdot\text{C})(T_{c,\text{out}} - 16^\circ\text{C})$$

It yields

$$T_{c,\text{out}} = 27.5^\circ\text{C} = 300.5\text{K}$$

The rate of entropy generation in the heating section in this case is determined similarly to be

$$\dot{S}_{\text{gen}} = \dot{m}c \ln \frac{T_2}{T_1} = (10/60 \text{ kg/s})(4.18 \text{ kJ/kg}\cdot\text{K}) \ln \frac{316 \text{ K}}{300.5 \text{ K}} = \mathbf{0.0350 \text{ kJ/K}}$$

Thus the reduction in the rate of entropy generation within the heating section is

$$\dot{S}_{\text{reduction}} = 0.0622 - 0.0350 = \mathbf{0.0272 \text{ kW/K}}$$

7-237 EES Using EES (or other) software, the work input to a multistage compressor is to be determined for a given set of inlet and exit pressures for any number of stages. The pressure ratio across each stage is assumed to be identical and the compression process to be polytropic. The compressor work is to be tabulated and plotted against the number of stages for $P_1 = 100$ kPa, $T_1 = 17^\circ\text{C}$, $P_2 = 800$ kPa, and $n = 1.35$ for air.

Analysis The problem is solved using EES, and the results are tabulated and plotted below.

```
GAS$ = 'Air'
Nstage = 2 "number of stages of compression with intercooling, each having same pressure ratio."
n=1.35
MM=MOLARMASS(GAS$)
R_u = 8.314 [kJ/kmol-K]
R=R_u/MM
k=1.4
P1=100 [kPa]
T1=17 [C]
P2=800 [kPa]
R_p = (P2/P1)^(1/Nstage)
W_dot_comp= Nstage*n*R*(T1+273)/((n-1)*((R_p)^((n-1)/n) - 1)
```

Nstage	W_{comp} [kJ/kg]
1	229.4
2	198.7
3	189.6
4	185.3
5	182.8
6	181.1
7	179.9
8	179
9	178.4
10	177.8

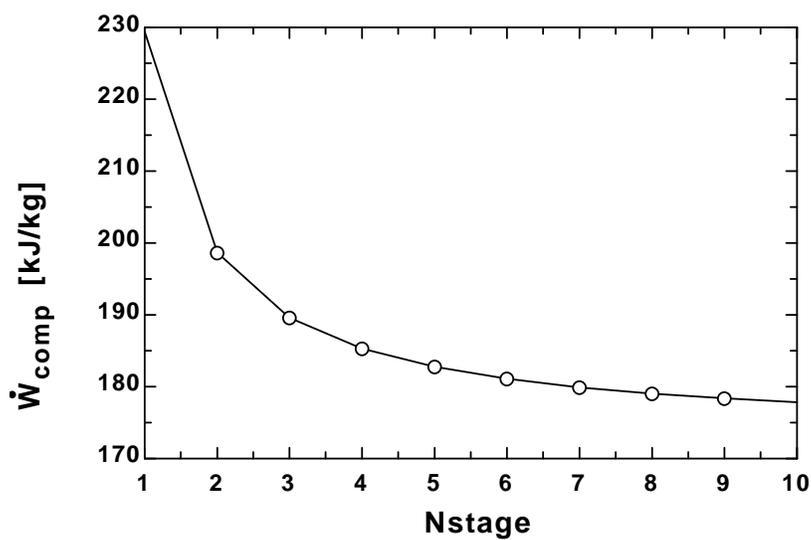

7-238 The turbocharger of an internal combustion engine consisting of a turbine driven by hot exhaust gases and a compressor driven by the turbine is considered. The air temperature at the compressor exit and the isentropic efficiency of the compressor are to be determined.

Assumptions **1** Steady operating conditions exist. **2** Kinetic and potential energy changes are negligible. **3** Exhaust gases have air properties and air is an ideal gas with constant specific heats.

Properties The specific heat of exhaust gases at the average temperature of 425°C is $c_p = 1.075$ kJ/kg.K and properties of air at an anticipated average temperature of 100°C are $c_p = 1.011$ kJ/kg.K and $k = 1.397$ (Table A-2).

Analysis (a) The turbine power output is determined from

$$\begin{aligned}\dot{W}_T &= \dot{m}_{\text{exh}} c_p (T_1 - T_2) \\ &= (0.02 \text{ kg/s})(1.075 \text{ kJ/kg}\cdot^\circ\text{C})(450 - 400)^\circ\text{C} = 1.075 \text{ kW}\end{aligned}$$

For a mechanical efficiency of 95% between the turbine and the compressor,

$$\dot{W}_C = \eta_m \dot{W}_T = (0.95)(1.075 \text{ kW}) = 1.021 \text{ kW}$$

Then, the air temperature at the compressor exit becomes

$$\begin{aligned}\dot{W}_C &= \dot{m}_{\text{air}} c_p (T_2 - T_1) \\ 1.021 \text{ kW} &= (0.018 \text{ kg/s})(1.011 \text{ kJ/kg}\cdot^\circ\text{C})(T_2 - 70)^\circ\text{C} \\ T_2 &= \mathbf{126.1^\circ\text{C}}\end{aligned}$$

(b) The air temperature at the compressor exit for the case of isentropic process is

$$T_{2s} = T_1 \left(\frac{P_2}{P_1} \right)^{(k-1)/k} = (70 + 273 \text{ K}) \left(\frac{135 \text{ kPa}}{95 \text{ kPa}} \right)^{(1.397-1)/1.397} = 379 \text{ K} = 106^\circ\text{C}$$

The isentropic efficiency of the compressor is determined to be

$$\eta_C = \frac{T_{2s} - T_1}{T_2 - T_1} = \frac{106 - 70}{126.1 - 70} = \mathbf{0.642}$$

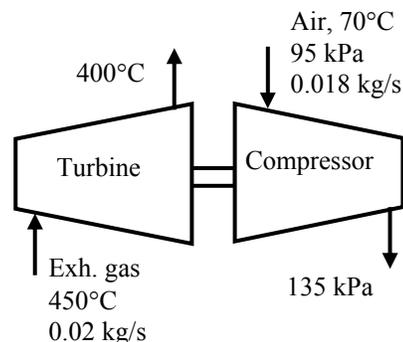

7-239 Air is allowed to enter an insulated piston-cylinder device until the volume of the air increases by 50%. The final temperature in the cylinder, the amount of mass that has entered, the work done, and the entropy generation are to be determined.

Assumptions 1 Kinetic and potential energy changes are negligible. **2** Air is an ideal gas with constant specific heats.

Properties The gas constant of air is $R = 0.287$ kJ/kg.K and the specific heats of air at room temperature are $c_p = 1.005$ kJ/kg.K, $c_v = 0.718$ kJ/kg.K (Table A-2).

Analysis The initial pressure in the cylinder is

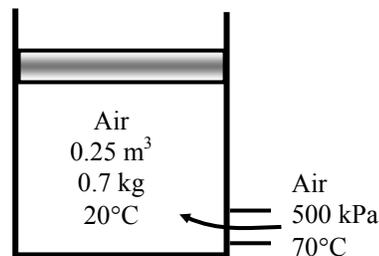

$$P_1 = \frac{m_1 R T_1}{V_1} = \frac{(0.7 \text{ kg})(0.287 \text{ kPa} \cdot \text{m}^3/\text{kg} \cdot \text{K})(20 + 273 \text{ K})}{0.25 \text{ m}^3} = 235.5 \text{ kPa}$$

$$m_2 = \frac{P_2 V_2}{R T_2} = \frac{(235.5 \text{ kPa})(1.5 \times 0.25 \text{ m}^3)}{(0.287 \text{ kPa} \cdot \text{m}^3/\text{kg} \cdot \text{K}) T_2} = \frac{307.71}{T_2}$$

A mass balance on the system gives the expression for the mass entering the cylinder

$$m_i = m_2 - m_1 = \frac{307.71}{T_2} - 0.7$$

(c) Noting that the pressure remains constant, the boundary work is determined to be

$$W_{b,\text{out}} = P_1 (V_2 - V_1) = (235.5 \text{ kPa})(1.5 \times 0.25 - 0.25) \text{ m}^3 = \mathbf{29.43 \text{ kJ}}$$

(a) An energy balance on the system may be used to determine the final temperature

$$m_i h_i - W_{b,\text{out}} = m_2 u_2 - m_1 u_1$$

$$m_i c_p T_i - W_{b,\text{out}} = m_2 c_v T_2 - m_1 c_v T_1$$

$$\left(\frac{307.71}{T_2} - 0.7 \right) (1.005)(70 + 273) - 29.43 = \left(\frac{307.71}{T_2} \right) (0.718) T_2 - (0.7)(0.718)(20 + 273)$$

There is only one unknown, which is the final temperature. By a trial-error approach or using EES, we find

$$T_2 = \mathbf{308.0 \text{ K}}$$

(b) The final mass and the amount of mass that has entered are

$$m_2 = \frac{307.71}{308.0} = 0.999 \text{ kg}$$

$$m_i = m_2 - m_1 = 0.999 - 0.7 = \mathbf{0.299 \text{ kg}}$$

(d) The rate of entropy generation is determined from

$$\begin{aligned} S_{\text{gen}} &= m_2 s_2 - m_1 s_1 - m_i s_i = m_2 s_2 - m_1 s_1 - (m_2 - m_1) s_i = m_2 (s_2 - s_i) - m_1 (s_1 - s_i) \\ &= m_2 \left(c_p \ln \frac{T_2}{T_i} - R \ln \frac{P_2}{P_i} \right) - m_1 \left(c_p \ln \frac{T_1}{T_i} - R \ln \frac{P_1}{P_i} \right) \\ &= (0.999 \text{ kg}) \left[(1.005 \text{ kJ/kg} \cdot \text{K}) \ln \left(\frac{308 \text{ K}}{343 \text{ K}} \right) - (0.287 \text{ kJ/kg} \cdot \text{K}) \ln \left(\frac{235.5 \text{ kPa}}{500 \text{ kPa}} \right) \right] \\ &\quad - (0.7 \text{ kg}) \left[(1.005 \text{ kJ/kg} \cdot \text{K}) \ln \left(\frac{293 \text{ K}}{343 \text{ K}} \right) - (0.287 \text{ kJ/kg} \cdot \text{K}) \ln \left(\frac{235.5 \text{ kPa}}{500 \text{ kPa}} \right) \right] \\ &= \mathbf{0.0673 \text{ kJ/K}} \end{aligned}$$

7-240 A cryogenic turbine in a natural gas liquefaction plant produces 350 kW of power. The efficiency of the turbine is to be determined.

Assumptions **1** The turbine operates steadily. **2** The properties of methane is used for natural gas.

Properties The density of natural gas is given to be 423.8 kg/m^3 .

Analysis The maximum possible power that can be obtained from this turbine for the given inlet and exit pressures can be determined from

$$\dot{W}_{\max} = \frac{\dot{m}}{\rho}(P_{\text{in}} - P_{\text{out}}) = \frac{(55 \text{ kg/s})}{423.8 \text{ kg/m}^3}(4000 - 300)\text{kPa} = 480.2 \text{ kW}$$

Given the actual power, the efficiency of this cryogenic turbine becomes

$$\eta = \frac{\dot{W}}{\dot{W}_{\max}} = \frac{350 \text{ kW}}{480.2 \text{ kW}} = \mathbf{0.729} = \mathbf{72.9\%}$$

This efficiency is also known as hydraulic efficiency since the cryogenic turbine handles natural gas in liquid state as the hydraulic turbine handles liquid water.

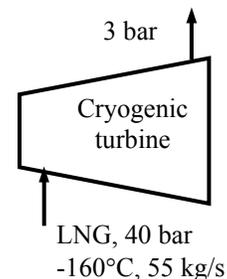

Fundamentals of Engineering (FE) Exam Problems

7-241 Steam is condensed at a constant temperature of 30°C as it flows through the condenser of a power plant by rejecting heat at a rate of 55 MW. The rate of entropy change of steam as it flows through the condenser is

- (a) -1.83 MW/K (b) -0.18 MW/K (c) 0 MW/K (d) 0.56 MW/K (e) 1.22 MW/K

Answer (b) -0.18 MW/K

Solution Solved by EES Software. Solutions can be verified by copying-and-pasting the following lines on a blank EES screen. (Similar problems and their solutions can be obtained easily by modifying numerical values).

```
T1=30 "C"
Q_out=55 "MW"
S_change=-Q_out/(T1+273) "MW/K"
```

"Some Wrong Solutions with Common Mistakes:"

```
W1_S_change=0 "Assuming no change"
W2_S_change=Q_out/T1 "Using temperature in C"
W3_S_change=Q_out/(T1+273) "Wrong sign"
W4_S_change=-s_fg "Taking entropy of vaporization"
s_fg=(ENTROPY(Steam_IAPWS,T=T1,x=1)-ENTROPY(Steam_IAPWS,T=T1,x=0))
```

7-242 Steam is compressed from 6 MPa and 300°C to 10 MPa isentropically. The final temperature of the steam is

- (a) 290°C (b) 300°C (c) 311°C (d) 371°C (e) 422°C

Answer (d) 371°C

Solution Solved by EES Software. Solutions can be verified by copying-and-pasting the following lines on a blank EES screen. (Similar problems and their solutions can be obtained easily by modifying numerical values).

```
P1=6000 "kPa"
T1=300 "C"
P2=10000 "kPa"
s2=s1
s1=ENTROPY(Steam_IAPWS,T=T1,P=P1)
T2=TEMPERATURE(Steam_IAPWS,s=s2,P=P2)
```

"Some Wrong Solutions with Common Mistakes:"

```
W1_T2=T1 "Assuming temperature remains constant"
W2_T2=TEMPERATURE(Steam_IAPWS,x=0,P=P2) "Saturation temperature at P2"
W3_T2=TEMPERATURE(Steam_IAPWS,x=0,P=P1) "Saturation temperature at P1"
```

7-243 An apple with an average mass of 0.15 kg and average specific heat of 3.65 kJ/kg·°C is cooled from 20°C to 5°C. The entropy change of the apple is

- (a) -0.0288 kJ/K (b) -0.192 kJ/K (c) -0.526 kJ/K (d) 0 kJ/K (e) 0.657 kJ/K

Answer (a) -0.0288 kJ/K

Solution Solved by EES Software. Solutions can be verified by copying-and-pasting the following lines on a blank EES screen. (Similar problems and their solutions can be obtained easily by modifying numerical values).

```
C=3.65 "kJ/kg.K"
m=0.15 "kg"
T1=20 "C"
T2=5 "C"
S_change=m*C*ln((T2+273)/(T1+273))
```

"Some Wrong Solutions with Common Mistakes:"
W1_S_change=C*ln((T2+273)/(T1+273)) "Not using mass"
W2_S_change=m*C*ln(T2/T1) "Using C"
W3_S_change=m*C*(T2-T1) "Using Wrong relation"

7-244 A piston-cylinder device contains 5 kg of saturated water vapor at 3 MPa. Now heat is rejected from the cylinder at constant pressure until the water vapor completely condenses so that the cylinder contains saturated liquid at 3 MPa at the end of the process. The entropy change of the system during this process is

- (a) 0 kJ/K (b) -3.5 kJ/K (c) -12.5 kJ/K (d) -17.7 kJ/K (e) -19.5 kJ/K

Answer (d) -17.7 kJ/K

Solution Solved by EES Software. Solutions can be verified by copying-and-pasting the following lines on a blank EES screen. (Similar problems and their solutions can be obtained easily by modifying numerical values).

```
P1=3000 "kPa"
m=5 "kg"
s_fg=(ENTROPY(Steam_IAPWS,P=P1,x=1)-ENTROPY(Steam_IAPWS,P=P1,x=0))
S_change=-m*s_fg "kJ/K"
```

7-245 Helium gas is compressed from 1 atm and 25°C to a pressure of 10 atm adiabatically. The lowest temperature of helium after compression is

- (a) 25°C (b) 63°C (c) 250°C (d) 384°C (e) 476°C

Answer (e) 476°C

Solution Solved by EES Software. Solutions can be verified by copying-and-pasting the following lines on a blank EES screen. (Similar problems and their solutions can be obtained easily by modifying numerical values).

```
k=1.667
P1=101.325 "kPa"
T1=25 "C"
P2=10*101.325 "kPa"
"s2=s1"
"The exit temperature will be lowest for isentropic compression,"
T2=(T1+273)*(P2/P1)^((k-1)/k) "K"
T2_C= T2-273 "C"
```

"Some Wrong Solutions with Common Mistakes:"
W1_T2=T1 "Assuming temperature remains constant"
W2_T2=T1*(P2/P1)^((k-1)/k) "Using C instead of K"
W3_T2=(T1+273)*(P2/P1)-273 "Assuming T is proportional to P"
W4_T2=T1*(P2/P1) "Assuming T is proportional to P, using C"

7-246 Steam expands in an adiabatic turbine from 8 MPa and 500°C to 0.1 MPa at a rate of 3 kg/s. If steam leaves the turbine as saturated vapor, the power output of the turbine is

- (a) 2174 kW (b) 698 kW (c) 2881 kW (d) 1674 kW (e) 3240 kW

Answer (a) 2174 kW

Solution Solved by EES Software. Solutions can be verified by copying-and-pasting the following lines on a blank EES screen. (Similar problems and their solutions can be obtained easily by modifying numerical values).

```
P1=8000 "kPa"
T1=500 "C"
P2=100 "kPa"
x2=1
m=3 "kg/s"
h1=ENTHALPY(Steam_IAPWS,T=T1,P=P1)
h2=ENTHALPY(Steam_IAPWS,x=x2,P=P2)
W_out=m*(h1-h2)
```

"Some Wrong Solutions with Common Mistakes:"
s1=ENTROPY(Steam_IAPWS,T=T1,P=P1)
h2s=ENTHALPY(Steam_IAPWS, s=s1,P=P2)
W1_Wout=m*(h1-h2s) "Assuming isentropic expansion"

7-247 Argon gas expands in an adiabatic turbine from 3 MPa and 750°C to 0.2 MPa at a rate of 5 kg/s. The maximum power output of the turbine is

- (a) 1.06 MW (b) 1.29 MW (c) 1.43 MW (d) 1.76 MW (e) 2.08 MW

Answer (d) 1.76 MW

Solution Solved by EES Software. Solutions can be verified by copying-and-pasting the following lines on a blank EES screen. (Similar problems and their solutions can be obtained easily by modifying numerical values).

```
Cp=0.5203
k=1.667
P1=3000 "kPa"
T1=750+273 "K"
m=5 "kg/s"
P2=200 "kPa"
"s2=s1"
T2=T1*(P2/P1)^((k-1)/k)
W_max=m*Cp*(T1-T2)
```

"Some Wrong Solutions with Common Mistakes:"

```
Cv=0.2081 "kJ/kg.K"
W1_Wmax=m*Cv*(T1-T2) "Using Cv"
T22=T1*(P2/P1)^((k-1)/k) "Using C instead of K"
W2_Wmax=m*Cp*(T1-T22)
W3_Wmax=Cp*(T1-T2) "Not using mass flow rate"
T24=T1*(P2/P1) "Assuming T is proportional to P, using C"
W4_Wmax=m*Cp*(T1-T24)
```

7-248 A unit mass of a substance undergoes an irreversible process from state 1 to state 2 while gaining heat from the surroundings at temperature T in the amount of q . If the entropy of the substance is s_1 at state 1, and s_2 at state 2, the entropy change of the substance Δs during this process is

- (a) $\Delta s < s_2 - s_1$ (b) $\Delta s > s_2 - s_1$ (c) $\Delta s = s_2 - s_1$ (d) $\Delta s = s_2 - s_1 + q/T$
 (e) $\Delta s > s_2 - s_1 + q/T$

Answer (c) $\Delta s = s_2 - s_1$

7-249 A unit mass of an ideal gas at temperature T undergoes a reversible isothermal process from pressure P_1 to pressure P_2 while losing heat to the surroundings at temperature T in the amount of q . If the gas constant of the gas is R , the entropy change of the gas Δs during this process is

- (a) $\Delta s = R \ln(P_2/P_1)$ (b) $\Delta s = R \ln(P_2/P_1) - q/T$ (c) $\Delta s = R \ln(P_1/P_2)$ (d) $\Delta s = R \ln(P_1/P_2) - q/T$
 (e) $\Delta s = 0$

Answer (c) $\Delta s = R \ln(P_1/P_2)$

7-250 Air is compressed from room conditions to a specified pressure in a reversible manner by two compressors: one isothermal and the other adiabatic. If the entropy change of air is Δs_{isot} during the reversible isothermal compression, and Δs_{adia} during the reversible adiabatic compression, the correct statement regarding entropy change of air per unit mass is

- (a) $\Delta s_{\text{isot}} = \Delta s_{\text{adia}} = 0$ (b) $\Delta s_{\text{isot}} = \Delta s_{\text{adia}} > 0$ (c) $\Delta s_{\text{adia}} > 0$ (d) $\Delta s_{\text{isot}} < 0$ (e) $\Delta s_{\text{isot}} = 0$

Answer (d) $\Delta s_{\text{isot}} < 0$

7-251 Helium gas is compressed from 15°C and 5.4 m³/kg to 0.775 m³/kg in a reversible adiabatic manner. The temperature of helium after compression is

- (a) 105°C (b) 55°C (c) 1734°C (d) 1051°C (e) 778°C

Answer (e) 778°C

Solution Solved by EES Software. Solutions can be verified by copying-and-pasting the following lines on a blank EES screen. (Similar problems and their solutions can be obtained easily by modifying numerical values).

```
k=1.667
v1=5.4 "m^3/kg"
T1=15 "C"
v2=0.775 "m^3/kg"
"s2=s1"
"The exit temperature is determined from isentropic compression relation,"
T2=(T1+273)*(v1/v2)^(k-1) "K"
T2_C= T2-273 "C"
```

"Some Wrong Solutions with Common Mistakes:"

```
W1_T2=T1 "Assuming temperature remains constant"
W2_T2=T1*(v1/v2)^(k-1) "Using C instead of K"
W3_T2=(T1+273)*(v1/v2)-273 "Assuming T is proportional to v"
W4_T2=T1*(v1/v2) "Assuming T is proportional to v, using C"
```

7-252 Heat is lost through a plane wall steadily at a rate of 600 W. If the inner and outer surface temperatures of the wall are 20°C and 5°C, respectively, the rate of entropy generation within the wall is

- (a) 0.11 W/K (b) 4.21 W/K (c) 2.10 W/K (d) 42.1 W/K (e) 90.0 W/K

Answer (a) 0.11 W/K

Solution Solved by EES Software. Solutions can be verified by copying-and-pasting the following lines on a blank EES screen. (Similar problems and their solutions can be obtained easily by modifying numerical values).

```
Q=600 "W"
T1=20+273 "K"
T2=5+273 "K"
"Entropy balance S_in - S_out + S_gen= DS_system for the wall for steady operation gives"
Q/T1-Q/T2+S_gen=0 "W/K"
```

"Some Wrong Solutions with Common Mistakes:"

```
Q/(T1+273)-Q/(T2+273)+W1_Sgen=0 "Using C instead of K"
W2_Sgen=Q/((T1+T2)/2) "Using average temperature in K"
W3_Sgen=Q/((T1+T2)/2-273) "Using average temperature in C"
W4_Sgen=Q/(T1-T2+273) "Using temperature difference in K"
```

7-253 Air is compressed steadily and adiabatically from 17°C and 90 kPa to 200°C and 400 kPa. Assuming constant specific heats for air at room temperature, the isentropic efficiency of the compressor is

- (a) 0.76 (b) 0.94 (c) 0.86 (d) 0.84 (e) 1.00

Answer (d) 0.84

Solution Solved by EES Software. Solutions can be verified by copying-and-pasting the following lines on a blank EES screen. (Similar problems and their solutions can be obtained easily by modifying numerical values).

```
Cp=1.005 "kJ/kg.K"
k=1.4
P1=90 "kPa"
T1=17 "C"
P2=400 "kPa"
T2=200 "C"
T2s=(T1+273)*(P2/P1)^((k-1)/k)-273
Eta_comp=(Cp*(T2s-T1))/(Cp*(T2-T1))
```

"Some Wrong Solutions with Common Mistakes:"

```
T2sW1=T1*(P2/P1)^((k-1)/k) "Using C instead of K in finding T2s"
W1_Eta_comp=(Cp*(T2sW1-T1))/(Cp*(T2-T1))
W2_Eta_comp=T2s/T2 "Using wrong definition for isentropic efficiency, and using C"
W3_Eta_comp=(T2s+273)/(T2+273) "Using wrong definition for isentropic efficiency, with K"
```

7-254 Argon gas expands in an adiabatic turbine steadily from 500°C and 800 kPa to 80 kPa at a rate of 2.5 kg/s. For an isentropic efficiency of 80%, the power produced by the turbine is

- (a) 194 kW (b) 291 kW (c) 484 kW (d) 363 kW (e) 605 kW

Answer (c) 484 kW

Solution Solved by EES Software. Solutions can be verified by copying-and-pasting the following lines on a blank EES screen. (Similar problems and their solutions can be obtained easily by modifying numerical values).

```
Cp=0.5203 "kJ/kg-K"
k=1.667
m=2.5 "kg/s"
T1=500 "C"
P1=800 "kPa"
P2=80 "kPa"
T2s=(T1+273)*(P2/P1)^((k-1)/k)-273
Eta_turb=0.8
Eta_turb=(Cp*(T2-T1))/(Cp*(T2s-T1))
W_out=m*Cp*(T1-T2)
```

"Some Wrong Solutions with Common Mistakes:"

```
T2sW1=T1*(P2/P1)^((k-1)/k) "Using C instead of K to find T2s"
Eta_turb=(Cp*(T2W1-T1))/(Cp*(T2sW1-T1))
W1_Wout=m*Cp*(T1-T2W1)
Eta_turb=(Cp*(T2s-T1))/(Cp*(T2W2-T1)) "Using wrong definition for isentropic efficiency, and
using C"
W2_Wout=m*Cp*(T1-T2W2)
W3_Wout=Cp*(T1-T2) "Not using mass flow rate"
Cv=0.3122 "kJ/kg.K"
W4_Wout=m*Cv*(T1-T2) "Using Cv instead of Cp"
```

7-255 Water enters a pump steadily at 100 kPa at a rate of 35 L/s and leaves at 800 kPa. The flow velocities at the inlet and the exit are the same, but the pump exit where the discharge pressure is measured is 6.1 m above the inlet section. The minimum power input to the pump is

- (a) 34 kW (b) 22 kW (c) 27 kW (d) 52 kW (e) 44 kW

Answer (c) 27 kW

Solution Solved by EES Software. Solutions can be verified by copying-and-pasting the following lines on a blank EES screen. (Similar problems and their solutions can be obtained easily by modifying numerical values).

```
V=0.035 "m^3/s"
g=9.81 "m/s^2"
h=6.1 "m"
P1=100 "kPa"
T1=20 "C"
P2=800 "kPa"
"Pump power input is minimum when compression is reversible and thus w=v(P2-P1)+Dpe"
v1=VOLUME(Steam_IAPWS,T=T1,P=P1)
m=V/v1
W_min=m*v1*(P2-P1)+m*g*h/1000 "kPa.m^3/s=kW"
"(The effect of 6.1 m elevation difference turns out to be small)"
```

"Some Wrong Solutions with Common Mistakes:"

```
W1_Win=m*v1*(P2-P1) "Disregarding potential energy"
W2_Win=m*v1*(P2-P1)-m*g*h/1000 "Subtracting potential energy instead of adding"
W3_Win=m*v1*(P2-P1)+m*g*h "Not using the conversion factor 1000 in PE term"
W4_Win=m*v1*(P2+P1)+m*g*h/1000 "Adding pressures instead of subtracting"
```

7-256 Air at 15°C is compressed steadily and isothermally from 100 kPa to 700 kPa at a rate of 0.12 kg/s. The minimum power input to the compressor is

- (a) 1.0 kW (b) 11.2 kW (c) 25.8 kW (d) 19.3 kW (e) 161 kW

Answer (d) 19.3 kW

Solution Solved by EES Software. Solutions can be verified by copying-and-pasting the following lines on a blank EES screen. (Similar problems and their solutions can be obtained easily by modifying numerical values).

```
Cp=1.005 "kJ/kg.K"
R=0.287 "kJ/kg.K"
Cv=0.718 "kJ/kg.K"
k=1.4
P1=100 "kPa"
T=15 "C"
m=0.12 "kg/s"
P2=700 "kPa"
Win=m*R*(T+273)*ln(P2/P1)
```

"Some Wrong Solutions with Common Mistakes:"

```
W1_Win=m*R*T*ln(P2/P1) "Using C instead of K"
W2_Win=m*T*(P2-P1) "Using wrong relation"
W3_Win=R*(T+273)*ln(P2/P1) "Not using mass flow rate"
```

7-257 Air is to be compressed steadily and isentropically from 1 atm to 25 atm by a two-stage compressor. To minimize the total compression work, the intermediate pressure between the two stages must be

- (a) 3 atm (b) 5 atm (c) 8 atm (d) 10 atm (e) 13 atm

Answer (b) 5 atm

Solution Solved by EES Software. Solutions can be verified by copying-and-pasting the following lines on a blank EES screen. (Similar problems and their solutions can be obtained easily by modifying numerical values).

```
P1=1 "atm"
P2=25 "atm"
P_mid=SQRT(P1*P2)
```

"Some Wrong Solutions with Common Mistakes:"

```
W1_P=(P1+P2)/2 "Using average pressure"
W2_P=P1*P2/2 "Half of product"
```

7-258 Helium gas enters an adiabatic nozzle steadily at 500°C and 600 kPa with a low velocity, and exits at a pressure of 90 kPa. The highest possible velocity of helium gas at the nozzle exit is

- (a) 1475 m/s (b) 1662 m/s (c) 1839 m/s (d) 2066 m/s (e) 3040 m/s

Answer (d) 2066 m/s

Solution Solved by EES Software. Solutions can be verified by copying-and-pasting the following lines on a blank EES screen. (Similar problems and their solutions can be obtained easily by modifying numerical values).

```

k=1.667
Cp=5.1926 "kJ/kg.K"
Cv=3.1156 "kJ/kg.K"
T1=500 "C"
P1=600 "kPa"
Vel1=0
P2=90 "kPa"
"s2=s1 for maximum exit velocity"
"The exit velocity will be highest for isentropic expansion,"
T2=(T1+273)*(P2/P1)^((k-1)/k)-273 "C"
"Energy balance for this case is h+ke=constant for the fluid stream (Q=W=pe=0)"
(0.5*Vel1^2)/1000+Cp*T1=(0.5*Vel2^2)/1000+Cp*T2

```

```

"Some Wrong Solutions with Common Mistakes:"
T2a=T1*(P2/P1)^((k-1)/k) "Using C for temperature"
(0.5*Vel1^2)/1000+Cp*T1=(0.5*W1_Vel2^2)/1000+Cp*T2a
T2b=T1*(P2/P1)^((k-1)/k) "Using Cv"
(0.5*Vel1^2)/1000+Cv*T1=(0.5*W2_Vel2^2)/1000+Cv*T2b
T2c=T1*(P2/P1)^k "Using wrong relation"
(0.5*Vel1^2)/1000+Cp*T1=(0.5*W3_Vel2^2)/1000+Cp*T2c

```

7-259 Combustion gases with a specific heat ratio of 1.3 enter an adiabatic nozzle steadily at 800°C and 800 kPa with a low velocity, and exit at a pressure of 85 kPa. The lowest possible temperature of combustion gases at the nozzle exit is

- (a) 43°C (b) 237°C (c) 367°C (d) 477°C (e) 640°C

Answer (c) 367°C

Solution Solved by EES Software. Solutions can be verified by copying-and-pasting the following lines on a blank EES screen. (Similar problems and their solutions can be obtained easily by modifying numerical values).

```
k=1.3
T1=800 "C"
P1=800 "kPa"
P2=85 "kPa"
"Nozzle exit temperature will be lowest for isentropic operation"
T2=(T1+273)*(P2/P1)^((k-1)/k)-273
```

```
"Some Wrong Solutions with Common Mistakes:"
W1_T2=T1*(P2/P1)^((k-1)/k) "Using C for temperature"
W2_T2=(T1+273)*(P2/P1)^((k-1)/k) "Not converting the answer to C"
W3_T2=T1*(P2/P1)^k "Using wrong relation"
```

7-260 Steam enters an adiabatic turbine steadily at 400°C and 3 MPa, and leaves at 50 kPa. The highest possible percentage of mass of steam that condenses at the turbine exit and leaves the turbine as a liquid is

- (a) 5% (b) 10% (c) 15% (d) 20% (e) 0%

Answer (b) 10%

Solution Solved by EES Software. Solutions can be verified by copying-and-pasting the following lines on a blank EES screen. (Similar problems and their solutions can be obtained easily by modifying numerical values).

```
P1=3000 "kPa"
T1=400 "C"
P2=50 "kPa"
s2=s1
s1=ENTROPY(Steam_IAPWS,T=T1,P=P1)
x2=QUALITY(Steam_IAPWS,s=s2,P=P2)
mixture=1-x2
"Checking x2 using data from table"
x2_table=(6.9212-1.091)/6.5029
```

7-261 Liquid water enters an adiabatic piping system at 15°C at a rate of 8 kg/s. If the water temperature rises by 0.2°C during flow due to friction, the rate of entropy generation in the pipe is

- (a) 23 W/K (b) 55 W/K (c) 68 W/K (d) 220 W/K (e) 443 W/K

Answer (a) 23 W/K

Solution Solved by EES Software. Solutions can be verified by copying-and-pasting the following lines on a blank EES screen. (Similar problems and their solutions can be obtained easily by modifying numerical values).

```
Cp=4180 "J/kg.K"
m=8 "kg/s"
T1=15 "C"
T2=15.2 "C"
S_gen=m*Cp*ln((T2+273)/(T1+273)) "W/K"
```

"Some Wrong Solutions with Common Mistakes:"

W1_Sgen=m*Cp*ln(T2/T1) "Using deg. C"

W2_Sgen=Cp*ln(T2/T1) "Not using mass flow rate with deg. C"

W3_Sgen=Cp*ln((T2+273)/(T1+273)) "Not using mass flow rate with deg. C"

7-262 Liquid water is to be compressed by a pump whose isentropic efficiency is 75 percent from 0.2 MPa to 5 MPa at a rate of 0.15 m³/min. The required power input to this pump is

- (a) 4.8 kW (b) 6.4 kW (c) 9.0 kW (d) 16.0 kW (e) 12.0 kW

Answer (d) 16.0 kW

Solution Solved by EES Software. Solutions can be verified by copying-and-pasting the following lines on a blank EES screen. (Similar problems and their solutions can be obtained easily by modifying numerical values).

```
V=0.15/60 "m^3/s"
rho=1000 "kg/m^3"
v1=1/rho
m=rho*V "kg/s"
P1=200 "kPa"
Eta_pump=0.75
P2=5000 "kPa"
"Reversible pump power input is w =mv(P2-P1) = V(P2-P1)"
W_rev=m*v1*(P2-P1) "kPa.m^3/s=kW"
W_pump=W_rev/Eta_pump
```

"Some Wrong Solutions with Common Mistakes:"

W1_Wpump=W_rev*Eta_pump "Multiplying by efficiency"

W2_Wpump=W_rev "Disregarding efficiency"

W3_Wpump=m*v1*(P2+P1)/Eta_pump "Adding pressures instead of subtracting"

7-263 Steam enters an adiabatic turbine at 8 MPa and 500°C at a rate of 18 kg/s, and exits at 0.2 MPa and 300°C. The rate of entropy generation in the turbine is

- (a) 0 kW/K (b) 7.2 kW/K (c) 21 kW/K (d) 15 kW/K (e) 17 kW/K

Answer (c) 21 kW/K

Solution Solved by EES Software. Solutions can be verified by copying-and-pasting the following lines on a blank EES screen. (Similar problems and their solutions can be obtained easily by modifying numerical values).

```
P1=8000 "kPa"
T1=500 "C"
m=18 "kg/s"
P2=200 "kPa"
T2=300 "C"
s1=ENTROPY(Steam_IAPWS,T=T1,P=P1)
s2=ENTROPY(Steam_IAPWS,T=T2,P=P2)
S_gen=m*(s2-s1) "kW/K"
```

"Some Wrong Solutions with Common Mistakes:"
W1_Sgen=0 "Assuming isentropic expansion"

7-264 Helium gas is compressed steadily from 90 kPa and 25°C to 600 kPa at a rate of 2 kg/min by an adiabatic compressor. If the compressor consumes 70 kW of power while operating, the isentropic efficiency of this compressor is

- (a) 56.7% (b) 83.7% (c) 75.4% (d) 92.1% (e) 100.0%

Answer (b) 83.7%

Solution Solved by EES Software. Solutions can be verified by copying-and-pasting the following lines on a blank EES screen. (Similar problems and their solutions can be obtained easily by modifying numerical values).

```
Cp=5.1926 "kJ/kg-K"
Cv=3.1156 "kJ/kg.K"
k=1.667
m=2/60 "kg/s"
T1=25 "C"
P1=90 "kPa"
P2=600 "kPa"
W_comp=70 "kW"
T2s=(T1+273)*(P2/P1)^((k-1)/k)-273
W_s=m*Cp*(T2s-T1)
Eta_comp=W_s/W_comp
```

"Some Wrong Solutions with Common Mistakes:"

T2sA=T1*(P2/P1)^((k-1)/k) "Using C instead of K"

W1_Eta_comp=m*Cp*(T2sA-T1)/W_comp

W2_Eta_comp=m*Cv*(T2s-T1)/W_comp "Using Cv instead of Cp"

7-265 ... 7-271 Design and Essay Problems

