

Steady-State Errors

7

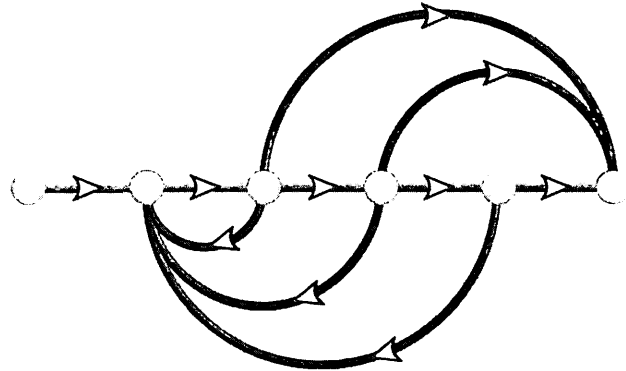

Chapter Learning Outcomes

After completing this chapter the student will be able to:

- Find the steady-state error for a unity feedback system (Sections 7.1–7.2)
- Specify a system's steady-state error performance (Section 7.3)
- Design the gain of a closed-loop system to meet a steady-state error specification (Section 7.4)
- Find the steady-state error for disturbance inputs (Section 7.5)
- Find the steady-state error for nonunity feedback systems (Section 7.6)
- Find the steady-state error sensitivity to parameter changes (Section 7.7)
- Find the steady-state error for systems represented in state space (Section 7.8)

Case Study Learning Outcomes

You will be able to demonstrate your knowledge of the chapter objectives with case studies as follows:

- Given the antenna azimuth position control system shown on the front endpapers, you will be able to find the preamplifier gain to meet steady-state error performance specifications.
- Given a video laser disc recorder, you will be able to find the gain required to permit the system to record on a warped disc.

7.1 Introduction

In Chapter 1, we saw that control systems analysis and design focus on three specifications: (1) transient response, (2) stability, and (3) steady-state errors, taking into account the robustness of the design along with economic and social considerations. Elements of transient analysis were derived in Chapter 4 for first- and second-order systems. These concepts are revisited in Chapter 8, where they are extended to higher-order systems. Stability was covered in Chapter 6, where we saw that forced responses were overpowered by natural responses that increase without bound if the system is unstable. Now we are ready to examine steady-state errors. We define the errors and derive methods of controlling them. As we progress, we find that control system design entails trade-offs between desired transient response, steady-state error, and the requirement that the system be stable.

Definition and Test Inputs

Steady-state error is the difference between the input and the output for a prescribed test input as $t \rightarrow \infty$. Test inputs used for steady-state error analysis and design are summarized in Table 7.1.

In order to explain how these test signals are used, let us assume a position control system, where the output position follows the input commanded position. Step inputs represent constant position and thus are useful in determining the ability of the control system to position itself with respect to a stationary target, such as a satellite in geostationary orbit (see Figure 7.1). An antenna position control is an example of a system that can be tested for accuracy using step inputs.

TABLE 7.1 Test waveforms for evaluating steady-state errors of position control systems

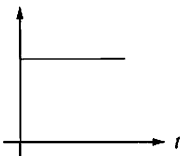
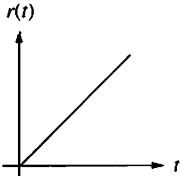
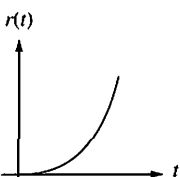
Waveform	Name	Physical interpretation	Time function	Laplace transform
	Step	Constant position	1	$\frac{1}{s}$
	Ramp	Constant velocity	t	$\frac{1}{s^2}$
	Parabola	Constant acceleration	$\frac{1}{2}t^2$	$\frac{1}{s^3}$

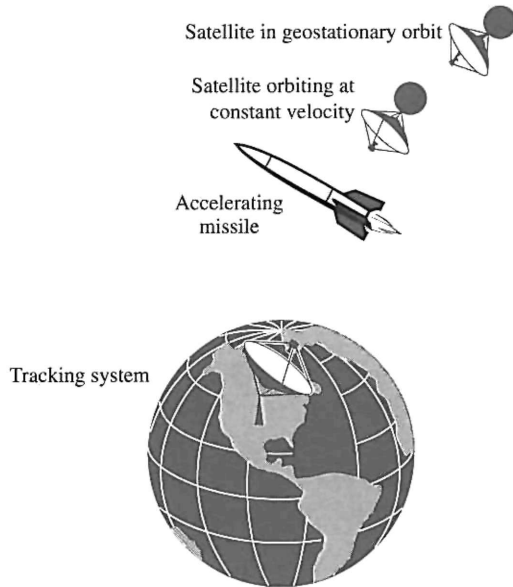

FIGURE 7.1 Test inputs for steady-state error analysis and design vary with target type

Ramp inputs represent constant-velocity inputs to a position control system by their linearly increasing amplitude. These waveforms can be used to test a system's ability to follow a linearly increasing input or, equivalently, to track a constant-velocity target. For example, a position control system that tracks a satellite that moves across the sky at a constant angular velocity, as shown in Figure 7.1, would be tested with a ramp input to evaluate the steady-state error between the satellite's angular position and that of the control system.

Finally, parabolas, whose second derivatives are constant, represent constant-acceleration inputs to position control systems and can be used to represent accelerating targets, such as the missile in Figure 7.1, to determine the steady-state error performance.

Application to Stable Systems

Since we are concerned with the difference between the input and the output of a feedback control system after the steady state has been reached, our discussion is limited to stable systems, where the natural response approaches zero as $t \rightarrow \infty$. Unstable systems represent loss of control in the steady state and are not acceptable for use at all. The expressions we derive to calculate the steady-state error can be applied erroneously to an unstable system. Thus, the engineer must check the system for stability while performing steady-state error analysis and design. However, in order to focus on the topic, we assume that all the systems in examples and problems in this chapter are stable. For practice, you may want to test some of the systems for stability.

Evaluating Steady-State Errors

Let us examine the concept of steady-state errors. In Figure 7.2(a) a step input and two possible outputs are shown. Output 1 has zero steady-state error, and output 2 has a finite steady-state error, $e_2(\infty)$. A similar example is shown in Figure 7.2(b), where a ramp input is compared with output 1, which has zero steady-state error, and output 2, which has a finite steady-state error, $e_2(\infty)$, as measured vertically between the input and output 2 after the transients have died down. For the ramp input

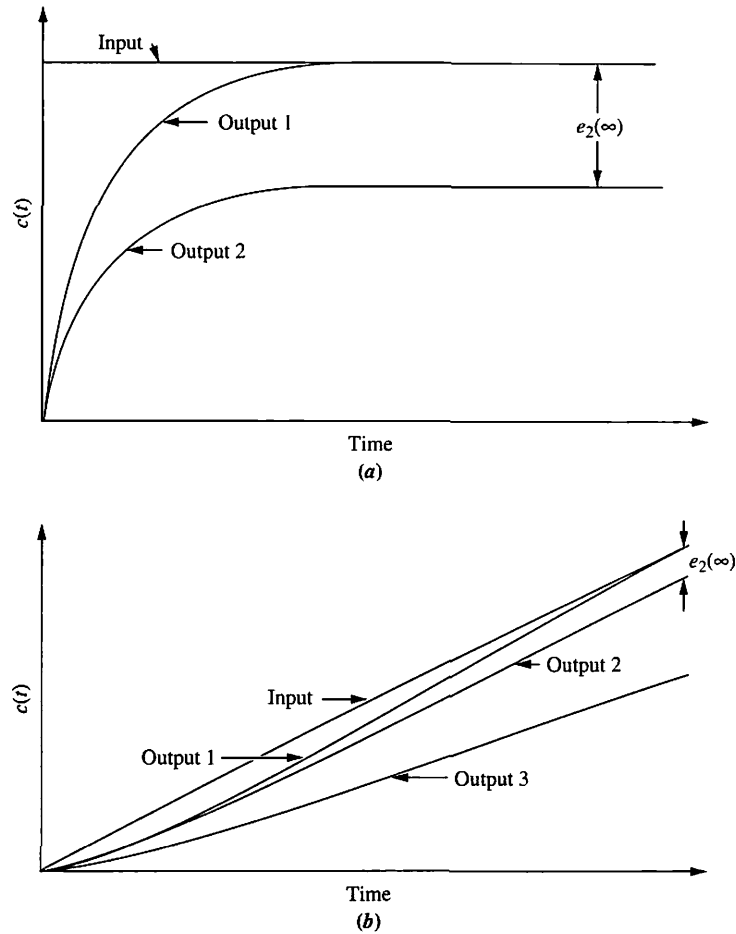

FIGURE 7.2 Steady-state error: **a.** step input; **b.** ramp input

another possibility exists. If the output's slope is different from that of the input, then output 3, shown in Figure 7.2(b), results. Here the steady-state error is infinite as measured vertically between the input and output 3 after the transients have died down, and t approaches infinity.

Let us now look at the error from the perspective of the most general block diagram. Since the error is the difference between the input and the output of a system, we assume a closed-loop transfer function, $T(s)$, and form the error, $E(s)$, by taking the difference between the input and the output, as shown in Figure 7.3(a). Here we are interested in the steady-state, or final, value of $e(t)$. For unity feedback systems, $E(s)$ appears as shown in Figure 7.3(b). In this chapter, we study and derive expressions for the steady-state error for unity feedback systems first and then expand to nonunity feedback systems. Before we begin our study of steady-state errors for unity feedback systems, let us look at the sources of the errors with which we deal.

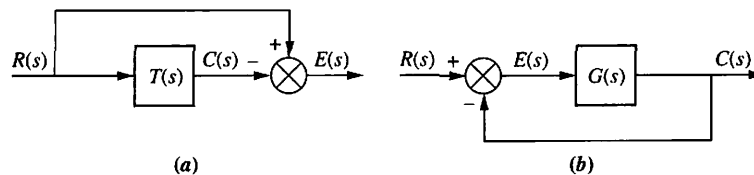

FIGURE 7.3 Closed-loop control system error: **a.** general representation; **b.** representation for unity feedback systems

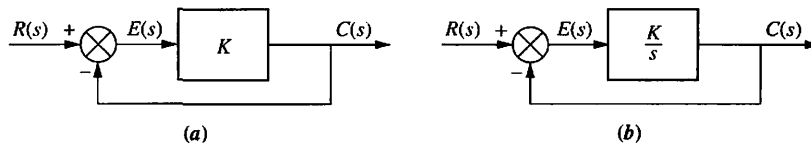

FIGURE 7.4 System with **a.** finite steady-state error for a step input; **b.** zero steady-state error for step input

Sources of Steady-State Error

Many steady-state errors in control systems arise from nonlinear sources, such as backlash in gears or a motor that will not move unless the input voltage exceeds a threshold. Nonlinear behavior as a source of steady-state errors, although a viable topic for study is beyond the scope of a text on linear control systems. The steady-state errors we study here are errors that arise from the configuration of the system itself and the type of applied input.

For example, look at the system of Figure 7.4(a), where $R(s)$ is the input, $C(s)$ is the output, and $E(s) = R(s) - C(s)$ is the error. Consider a step input. In the steady state, if $c(t)$ equals $r(t)$, $e(t)$ will be zero. But with a pure gain, K , the error, $e(t)$, cannot be zero if $c(t)$ is to be finite and nonzero. Thus, by virtue of the configuration of the system (a pure gain of K in the forward path), an error must exist. If we call $c_{\text{steady-state}}$ the steady-state value of the output and $e_{\text{steady-state}}$ the steady-state value of the error, then $c_{\text{steady-state}} = Ke_{\text{steady-state}}$, or

$$e_{\text{steady-state}} = \frac{1}{K} c_{\text{steady-state}} \quad (7.1)$$

Thus, the larger the value of K , the smaller the value of $e_{\text{steady-state}}$ would have to be to yield a similar value of $c_{\text{steady-state}}$. The conclusion we can draw is that with a pure gain in the forward path, there will always be a steady-state error for a step input. This error diminishes as the value of K increases.

If the forward-path gain is replaced by an integrator, as shown in Figure 7.4(b), there will be zero error in the steady state for a step input. The reasoning is as follows: As $c(t)$ increases, $e(t)$ will decrease, since $e(t) = r(t) - c(t)$. This decrease will continue until there is zero error, but there will still be a value for $c(t)$ since an integrator can have a constant output without any input. For example, a motor can be represented simply as an integrator. A voltage applied to the motor will cause rotation. When the applied voltage is removed, the motor will stop and remain at its present output position. Since it does not return to its initial position, we have an angular displacement output without an input to the motor. Therefore, a system similar to Figure 7.4(b), which uses a motor in the forward path, can have zero steady-state error for a step input.

We have examined two cases qualitatively to show how a system can be expected to exhibit various steady-state error characteristics, depending upon the system configuration. We now formalize the concepts and derive the relationships between the steady-state errors and the system configuration generating these errors.

7.2 Steady-State Error for Unity Feedback Systems

Steady-state error can be calculated from a system's closed-loop transfer function, $T(s)$, or the open-loop transfer function, $G(s)$, for unity feedback systems. We begin by deriving the system's steady-state error in terms of the closed-loop transfer

function, $T(s)$, in order to introduce the subject and the definitions. Next we obtain insight into the factors affecting steady-state error by using the open-loop transfer function, $G(s)$, in unity feedback systems for our calculations. Later in the chapter we generalize this discussion to nonunity feedback systems.

Steady-State Error in Terms of $T(s)$

Consider Figure 7.3(a). To find $E(s)$, the error between the input, $R(s)$, and the output, $C(s)$, we write

$$E(s) = R(s) - C(s) \quad (7.2)$$

But

$$C(s) = R(s)T(s) \quad (7.3)$$

Substituting Eq. (7.3) into Eq. (7.2), simplifying, and solving for $E(s)$ yields

$$E(s) = R(s)[1 - T(s)] \quad (7.4)$$

Although Eq. (7.4) allows us to solve for $e(t)$ at any time, t , we are interested in the final value of the error, $e(\infty)$. Applying the final value theorem,¹ which allows us to use the final value of $e(t)$ without taking the inverse Laplace transform of $E(s)$, and then letting t approach infinity, we obtain

$$e(\infty) = \lim_{t \rightarrow \infty} e(t) = \lim_{s \rightarrow 0} sE(s) \quad (7.5)^2$$

Substituting Eq. (7.4) into Eq. (7.5) yields

$$e(\infty) = \lim_{s \rightarrow 0} sR(s)[1 - T(s)] \quad (7.6)$$

Let us look at an example.

¹The final value theorem is derived from the Laplace transform of the derivative. Thus,

$$\mathcal{L}[\dot{f}(t)] = \int_{0^-}^{\infty} \dot{f}(t)e^{st} dt = sF(s) - f(0^-)$$

As $s \rightarrow 0$,

$$\int_{0^-}^{\infty} \dot{f}(t) dt = f(\infty) - f(0^-) = \lim_{s \rightarrow 0} sF(s) - f(0^-)$$

or

$$f(\infty) = \lim_{s \rightarrow 0} sF(s)$$

For finite steady-state errors, the final value theorem is valid only if $F(s)$ has poles only in the left half-plane and, at most, one pole at the origin. However, correct results that yield steady-state errors that are infinite can be obtained if $F(s)$ has more than one pole at the origin (see *D'Azzo and Houpis, 1988*). If $F(s)$ has poles in the right half-plane or poles on the imaginary axis other than at the origin, the final value theorem is invalid.

²Valid only if (1) $E(s)$ has poles only in the left half-plane and at the origin, and (2) the closed-loop transfer function, $T(s)$, is stable. Notice that by using Eq. (7.5), numerical results can be obtained for unstable systems. These results, however, are meaningless.

Example 7.1

Steady-State Error in Terms of $T(s)$

PROBLEM: Find the steady-state error for the system of Figure 7.3(a) if $T(s) = 5/(s^2 + 7s + 10)$ and the input is a unit step.

SOLUTION: From the problem statement, $R(s) = 1/s$ and $T(s) = 5/(s^2 + 7s + 10)$. Substituting into Eq. (7.4) yields

$$E(s) = \frac{s^2 + 7s + 5}{s(s^2 + 7s + 10)} \quad (7.7)$$

Since $T(s)$ is stable and, subsequently, $E(s)$ does not have right-half-plane poles or $j\omega$ poles other than at the origin, we can apply the final value theorem. Substituting Eq. (7.7) into Eq. (7.5) gives $e(\infty) = 1/2$.

Steady-State Error in Terms of $G(s)$

Many times we have the system configured as a unity feedback system with a forward transfer function, $G(s)$. Although we can find the closed-loop transfer function, $T(s)$, and then proceed as in the previous subsection, we find more insight for analysis and design by expressing the steady-state error in terms of $G(s)$ rather than $T(s)$.

Consider the feedback control system shown in Figure 7.3(b). Since the feedback, $H(s)$, equals 1, the system has unity feedback. The implication is that $E(s)$ is actually the error between the input, $R(s)$, and the output, $C(s)$. Thus, if we solve for $E(s)$, we will have an expression for the error. We will then apply the final value theorem, Item 11 in Table 2.2, to evaluate the steady-state error.

Writing $E(s)$ from Figure 7.3(b), we obtain

$$E(s) = R(s) - C(s) \quad (7.8)$$

But

$$C(s) = E(s)G(s) \quad (7.9)$$

Finally, substituting Eq. (7.9) into Eq. (7.8) and solving for $E(s)$ yields

$$E(s) = \frac{R(s)}{1 + G(s)} \quad (7.10)$$

We now apply the final value theorem, Eq. (7.5). At this point in a numerical calculation, we must check to see whether the closed-loop system is stable, using, for example, the Routh-Hurwitz criterion. For now, though, assume that the closed-loop system is stable and substitute Eq. (7.10) into Eq. (7.5), obtaining

$$e(\infty) = \lim_{s \rightarrow 0} \frac{sR(s)}{1 + G(s)} \quad (7.11)$$

Equation (7.11) allows us to calculate the steady-state error, $e(\infty)$, given the input, $R(s)$, and the system, $G(s)$. We now substitute several inputs for $R(s)$ and then

draw conclusions about the relationships that exist between the open-loop system, $G(s)$, and the nature of the steady-state error, $e(\infty)$.

The three test signals we use to establish specifications for a control system's steady-state error characteristics are shown in Table 7.1. Let us take each input and evaluate its effect on the steady-state error by using Eq. (7.11).

Step Input. Using Eq. (7.11) with $R(s) = 1/s$, we find

$$e(\infty) = e_{\text{step}}(\infty) = \lim_{s \rightarrow 0} \frac{s(1/s)}{1 + G(s)} = \frac{1}{1 + \lim_{s \rightarrow 0} G(s)} \quad (7.12)$$

The term

$$\lim_{s \rightarrow 0} G(s)$$

is the dc gain of the forward transfer function, since s , the frequency variable, is approaching zero. In order to have zero steady-state error,

$$\lim_{s \rightarrow 0} G(s) = \infty \quad (7.13)$$

Hence, to satisfy Eq. (7.13), $G(s)$ must take on the following form:

$$G(s) \equiv \frac{(s + z_1)(s + z_2) \cdots}{s^n (s + p_1)(s + p_2) \cdots} \quad (7.14)$$

and for the limit to be infinite, the denominator must be equal to zero as s goes to zero. Thus, $n \geq 1$; that is, at least one pole must be at the origin. Since division by s in the frequency domain is integration in the time domain (see Table 2.2, Item 10), we are also saying that at least one pure integration must be present in the forward path. The steady-state response for this case of zero steady-state error is similar to that shown in Figure 7.2(a), output 1.

If there are no integrations, then $n = 0$. Using Eq. (7.14), we have

$$\lim_{s \rightarrow 0} G(s) = \frac{z_1 z_2 \cdots}{p_1 p_2 \cdots} \quad (7.15)$$

which is finite and yields a finite error from Eq. (7.12). Figure 7.2(a), output 2, is an example of this case of finite steady-state error.

In summary, for a step input to a unity feedback system, the steady-state error will be zero if there is at least one pure integration in the forward path. If there are no integrations, then there will be a nonzero finite error. This result is comparable to our qualitative discussion in Section 7.1, where we found that a pure gain yields a constant steady-state error for a step input, but an integrator yields zero error for the same type of input. We now repeat the development for a ramp input.

Ramp Input. Using Eq. (7.11) with $R(s) = 1/s^2$, we obtain

$$e(\infty) = e_{\text{ramp}}(\infty) = \lim_{s \rightarrow 0} \frac{s(1/s^2)}{1 + G(s)} = \lim_{s \rightarrow 0} \frac{1}{s + sG(s)} = \frac{1}{\lim_{s \rightarrow 0} sG(s)} \quad (7.16)$$

To have zero steady-state error for a ramp input, we must have

$$\lim_{s \rightarrow 0} sG(s) = \infty \quad (7.17)$$

To satisfy Eq. (7.17), $G(s)$ must take the same form as Eq. (7.14), except that $n \geq 2$. In other words, there must be at least two integrations in the forward path. An example of zero steady-state error for a ramp input is shown in Figure 7.2(b), output 1.

If only one integration exists in the forward path, then, assuming Eq. (7.14),

$$\lim_{s \rightarrow 0} sG(s) = \frac{z_1 z_2 \cdots}{p_1 p_2 \cdots} \quad (7.18)$$

which is finite rather than infinite. Using Eq. (7.16), we find that this configuration leads to a constant error, as shown in Figure 7.2(b), output 2.

If there are no integrations in the forward path, then

$$\lim_{s \rightarrow 0} sG(s) = 0 \quad (7.19)$$

and the steady-state error would be infinite and lead to diverging ramps, as shown in Figure 7.2(b), output 3. Finally, we repeat the development for a parabolic input.

Parabolic Input. Using Eq. (7.11) with $R(s) = 1/s^3$, we obtain

$$e(\infty) = e_{\text{parabola}}(\infty) = \lim_{s \rightarrow 0} \frac{s(1/s^3)}{1 + G(s)} = \lim_{s \rightarrow 0} \frac{1}{s^2 + s^2 G(s)} = \frac{1}{\lim_{s \rightarrow 0} s^2 G(s)} \quad (7.20)$$

In order to have zero steady-state error for a parabolic input, we must have

$$\lim_{s \rightarrow 0} s^2 G(s) = \infty \quad (7.21)$$

To satisfy Eq. (7.21), $G(s)$ must take on the same form as Eq. (7.14), except that $n \geq 3$. In other words, there must be at least three integrations in the forward path.

If there are only two integrations in the forward path, then

$$\lim_{s \rightarrow 0} s^2 G(s) = \frac{z_1 z_2 \cdots}{p_1 p_2 \cdots} \quad (7.22)$$

is finite rather than infinite. Using Eq. (7.20), we find that this configuration leads to a constant error.

If there is only one or less integration in the forward path, then

$$\lim_{s \rightarrow 0} s^2 G(s) = 0 \quad (7.23)$$

and the steady-state error is infinite. Two examples demonstrate these concepts.

Example 7.2

Steady-State Errors for Systems with No Integrations

PROBLEM: Find the steady-state errors for inputs of $5u(t)$, $5tu(t)$, and $5t^2u(t)$ to the system shown in Figure 7.5. The function $u(t)$ is the unit step.

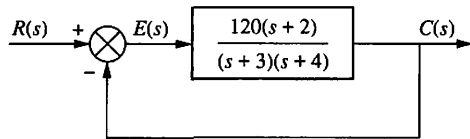

FIGURE 7.5 Feedback control system for Example 7.2

SOLUTION: First we verify that the closed-loop system is indeed stable. For this example we leave out the details. Next, for the input $5u(t)$, whose Laplace transform is $5/s$, the steady-state error will be five times as large as that given by Eq. (7.12), or

$$e(\infty) = e_{\text{step}}(\infty) = \frac{5}{1 + \lim_{s \rightarrow 0} G(s)} = \frac{5}{1 + 20} = \frac{5}{21} \quad (7.24)$$

which implies a response similar to output 2 of Figure 7.2(a).

For the input $5tu(t)$, whose Laplace transform is $5/s^2$, the steady-state error will be five times as large as that given by Eq. (7.16), or

$$e(\infty) = e_{\text{ramp}}(\infty) = \frac{5}{\lim_{s \rightarrow 0} sG(s)} = \frac{5}{0} = \infty \quad (7.25)$$

which implies a response similar to output 3 of Figure 7.2(b).

For the input $5t^2u(t)$, whose Laplace transform is $10/s^3$, the steady-state error will be 10 times as large as that given by Eq. (7.20), or

$$e(\infty) = e_{\text{parabola}}(\infty) = \frac{10}{\lim_{s \rightarrow 0} s^2 G(s)} = \frac{10}{0} = \infty \quad (7.26)$$

Example 7.3

Steady-State Errors for Systems with One Integration

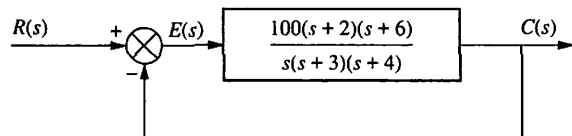

FIGURE 7.6 Feedback control system for Example 7.3

PROBLEM: Find the steady-state errors for inputs of $5u(t)$, $5tu(t)$, and $5t^2u(t)$ to the system shown in Figure 7.6. The function $u(t)$ is the unit step.

SOLUTION: First verify that the closed-loop system is indeed stable. For this example we leave out the details. Next note that since there is an integration in the forward path, the steady-state errors for some of the input waveforms will be

less than those found in Example 7.2. For the input $5u(t)$, whose Laplace transform is $5/s$, the steady-state error will be five times as large as that given by Eq. (7.12), or

$$e(\infty) = e_{\text{step}}(\infty) = \frac{5}{1 + \lim_{s \rightarrow 0} G(s)} = \frac{5}{\infty} = 0 \quad (7.27)$$

which implies a response similar to output 1 of Figure 7.2(a). Notice that the integration in the forward path yields zero error for a step input, rather than the finite error found in Example 7.2.

For the input $5tu(t)$, whose Laplace transform is $5/s^2$, the steady-state error will be five times as large as that given by Eq. (7.16), or

$$e(\infty) = e_{\text{ramp}}(\infty) = \frac{5}{\lim_{s \rightarrow 0} sG(s)} = \frac{5}{100} = \frac{1}{20} \quad (7.28)$$

which implies a response similar to output 2 of Figure 7.2(b). Notice that the integration in the forward path yields a finite error for a ramp input, rather than the infinite error found in Example 7.2.

For the input, $5t^2u(t)$, whose Laplace transform is $10/s^3$, the steady-state error will be 10 times as large as that given by Eq. (7.20), or

$$e(\infty) = e_{\text{parabola}}(\infty) = \frac{10}{\lim_{s \rightarrow 0} s^2 G(s)} = \frac{10}{0} = \infty \quad (7.29)$$

Notice that the integration in the forward path does not yield any improvement in steady-state error over that found in Example 7.2 for a parabolic input.

Skill-Assessment Exercise 7.1

PROBLEM: A unity feedback system has the following forward transfer function:

$$G(s) = \frac{10(s+20)(s+30)}{s(s+25)(s+35)}$$

WileyPLUS
WPCS
 Control Solutions

- Find the steady-state error for the following inputs: $15u(t)$, $15tu(t)$, and $15t^2u(t)$.
- Repeat for

$$G(s) = \frac{10(s+20)(s+30)}{s^2(s+25)(s+35)(s+50)}$$

ANSWERS:

- The closed-loop system is stable. For $15u(t)$, $e_{\text{step}}(\infty) = 0$; for $15tu(t)$, $e_{\text{ramp}}(\infty) = 2.1875$; for $15(t^2)u(t)$, $e_{\text{parabola}}(\infty) = \infty$.
- The closed-loop system is unstable. Calculations cannot be made.

The complete solution is at www.wiley.com/college/nise.

7.3 Static Error Constants and System Type

We continue our focus on unity negative feedback systems and define parameters that we can use as steady-state error performance specifications, just as we defined damping ratio, natural frequency, settling time, percent overshoot, and so on as performance specifications for the transient response. These steady-state error performance specifications are called *static error constants*. Let us see how they are defined, how to calculate them, and, in the next section, how to use them for design.

Static Error Constants

In the previous section we derived the following relationships for steady-state error. For a step input, $u(t)$,

$$e(\infty) = e_{\text{step}}(\infty) = \frac{1}{1 + \lim_{s \rightarrow 0} G(s)} \quad (7.30)$$

For a ramp input, $tu(t)$,

$$e(\infty) = e_{\text{ramp}}(\infty) = \frac{1}{\lim_{s \rightarrow 0} sG(s)} \quad (7.31)$$

For a parabolic input, $\frac{1}{2}t^2u(t)$.

$$e(\infty) = e_{\text{parabola}}(\infty) = \frac{1}{\lim_{s \rightarrow 0} s^2G(s)} \quad (7.32)$$

The three terms in the denominator that are taken to the limit determine the steady-state error. We call these limits *static error constants*. Individually, their names are *position constant*, K_p , where

$$K_p = \lim_{s \rightarrow 0} G(s) \quad (7.33)$$

velocity constant, K_v , where

$$K_v = \lim_{s \rightarrow 0} sG(s) \quad (7.34)$$

acceleration constant, K_a , where

$$K_a = \lim_{s \rightarrow 0} s^2G(s) \quad (7.35)$$

As we have seen, these quantities, depending upon the form of $G(s)$, can assume values of zero, finite constant, or infinity. Since the static error constant appears in the denominator of the steady-state error. Eqs. (7.30) through (7.32), the value of the steady-state error decreases as the static error constant increases.

In Section 7.2, we evaluated the steady-state error by using the final value theorem. An alternate method makes use of the static error constants. A few examples follow.

Example 7.4

Steady-State Error via Static Error Constants

PROBLEM: For each system of Figure 7.7, evaluate the static error constants and find the expected error for the standard step, ramp, and parabolic inputs.

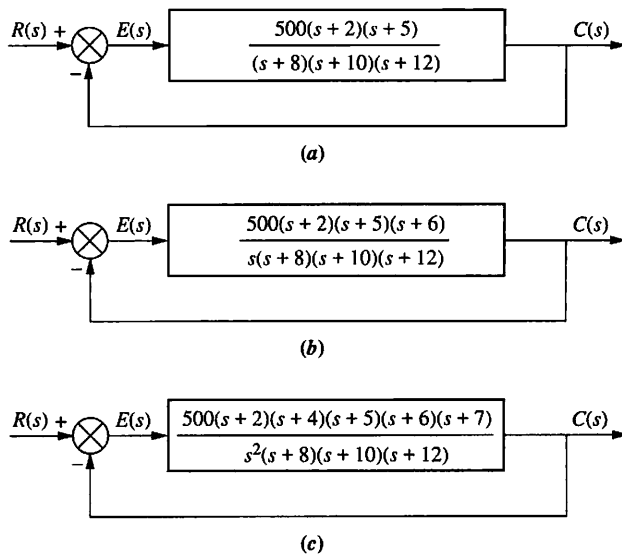

FIGURE 7.7 Feedback control systems for Example 7.4

SOLUTION: First verify that all closed-loop systems shown are indeed stable. For this example we leave out the details. Next, for Figure 7.7(a),

$$K_p = \lim_{s \rightarrow 0} G(s) = \frac{500 \times 2 \times 5}{8 \times 10 \times 12} = 5.208 \quad (7.36)$$

$$K_v = \lim_{s \rightarrow 0} sG(s) = 0 \quad (7.37)$$

$$K_a = \lim_{s \rightarrow 0} s^2 G(s) = 0 \quad (7.38)$$

Thus, for a step input,

$$e(\infty) = \frac{1}{1 + K_p} = 0.161 \quad (7.39)$$

For a ramp input,

$$e(\infty) = \frac{1}{K_v} = \infty \quad (7.40)$$

For a parabolic input,

$$e(\infty) = \frac{1}{K_a} = \infty \quad (7.41)$$

Now, for Figure 7.7(b),

$$K_p = \lim_{s \rightarrow 0} G(s) = \infty \quad (7.42)$$

$$K_v = \lim_{s \rightarrow 0} sG(s) = \frac{500 \times 2 \times 5 \times 6}{8 \times 10 \times 12} = 31.25 \quad (7.43)$$

and

$$K_a = \lim_{s \rightarrow 0} s^2 G(s) = 0 \quad (7.44)$$

Thus, for a step input,

$$e(\infty) = \frac{1}{1 + K_p} = 0 \quad (7.45)$$

For a ramp input,

$$e(\infty) = \frac{1}{K_v} = \frac{1}{31.25} = 0.032 \quad (7.46)$$

For a parabolic input,

$$e(\infty) = \frac{1}{K_a} = \infty \quad (7.47)$$

Finally, for Figure 7.7(c),

$$K_p = \lim_{s \rightarrow 0} G(s) = \infty \quad (7.48)$$

$$K_v = \lim_{s \rightarrow 0} sG(s) = \infty \quad (7.49)$$

and

$$K_a = \lim_{s \rightarrow 0} s^2 G(s) = \frac{500 \times 2 \times 4 \times 5 \times 6 \times 7}{8 \times 10 \times 12} = 875 \quad (7.50)$$

Thus, for a step input,

$$e(\infty) = \frac{1}{1 + K_p} = 0 \quad (7.51)$$

For a ramp input,

$$e(\infty) = \frac{1}{K_v} = 0 \quad (7.52)$$

For a parabolic input,

$$e(\infty) = \frac{1}{K_a} = \frac{1}{875} = 1.14 \times 10^{-3} \quad (7.53)$$

MATLAB

ML

Students who are using MATLAB should now run ch7pl in Appendix B. You will learn how to test the system for stability, evaluate static error constants, and calculate steady-state error using MATLAB. This exercise applies MATLAB to solve Example 7.4 with System (b).

System Type

Let us continue to focus on a unity negative feedback system. The values of the static error constants, again, depend upon the form of $G(s)$, especially the number of pure integrations in the forward path. Since steady-state errors are dependent upon the

number of integrations in the forward path, we give a name to this system attribute. Given the system in Figure 7.8, we define *system type* to be the value of n in the denominator or, equivalently, the number of pure integrations in the forward path. Therefore, a system with $n = 0$ is a Type 0 system. If $n = 1$ or $n = 2$, the corresponding system is a Type 1 or Type 2 system, respectively.

Table 7.2 ties together the concepts of steady-state error, static error constants, and system type. The table shows the static error constants and the steady-state errors as functions of input waveform and system type.

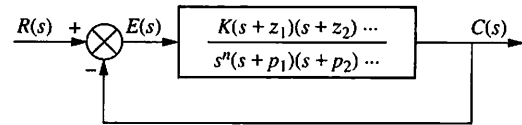

FIGURE 7.8 Feedback control system for defining system type

TABLE 7.2 Relationships between input, system type, static error constants, and steady-state errors

Input	Steady-state error formula	Type 0		Type 1		Type 2	
		Static error constant	Error	Static error constant	Error	Static error constant	Error
Step, $u(t)$	$\frac{1}{1 + K_p}$	$K_p = \text{Constant}$	$\frac{1}{1 + K_p}$	$K_p = \infty$	0	$K_p = \infty$	0
Ramp, $tu(t)$	$\frac{1}{K_v}$	$K_v = 0$	∞	$K_v = \text{Constant}$	$\frac{1}{K_v}$	$K_v = \infty$	0
Parabola, $\frac{1}{2}t^2u(t)$	$\frac{1}{K_a}$	$K_a = 0$	∞	$K_a = 0$	∞	$K_a = \text{Constant}$	$\frac{1}{K_a}$

Skill-Assessment Exercise 7.2

PROBLEM: A unity feedback system has the following forward transfer function:

$$G(s) = \frac{1000(s + 8)}{(s + 7)(s + 9)}$$

- Evaluate system type, K_p , K_v , and K_a .
- Use your answers to **a.** to find the steady-state errors for the standard step, ramp, and parabolic inputs.

ANSWERS:

- The closed-loop system is stable. System type = Type 0. $K_p = 127$, $K_v = 0$, and $K_a = 0$.
- $e_{\text{step}}(\infty) = 7.8 \times 10^{-3}$, $e_{\text{ramp}}(\infty) = \infty$, and $e_{\text{parabola}}(\infty) = \infty$

The complete solution is at www.wiley.com/college/nise.

TryIt 7.1

Use MATLAB, the Control System Toolbox, and the following statements to find K_p , $e_{\text{step}}(\infty)$, and the closed-loop poles to check for stability for the system of Skill-Assessment Exercise 7.2.

```
numg=1000*[1 8];
deng=poly([-7 -9]);
G=tf(numg,deng);
Kp=dcgain(G)
estep=1/(1+Kp)
T=feedback(G,1);
poles=pole(T)
```

In this section, we defined steady-state errors, static error constants, and system type. Now the specifications for a control system's steady-state errors will be formulated, followed by some examples.

7.4 Steady-State Error Specifications

Static error constants can be used to specify the steady-state error characteristics of control systems, such as that shown in Figure 7.9. Just as damping ratio, ζ , settling time, T_s , peak time, T_p , and percent overshoot, %OS, are used as specifications for a

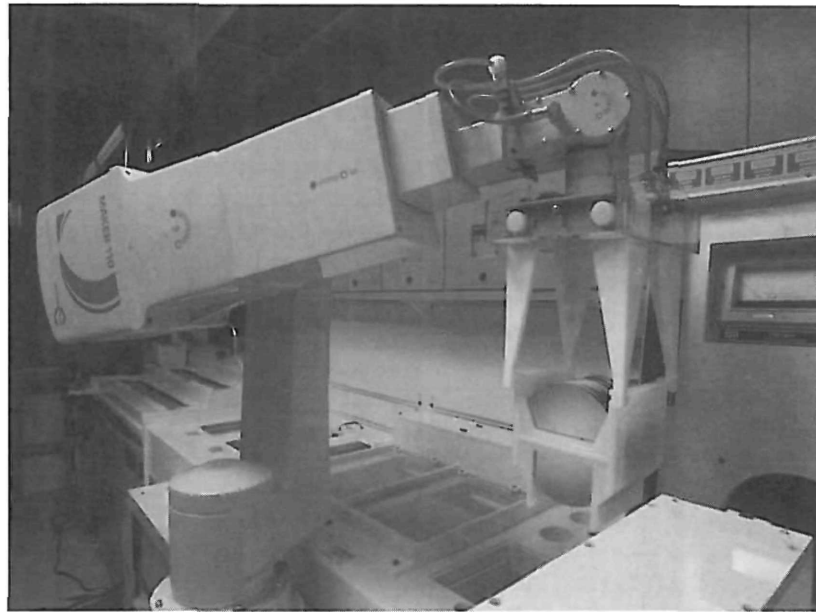

FIGURE 7.9 A robot used in the manufacturing of semiconductor random-access memories (RAMs) similar to those in personal computers. Steady-state error is an important design consideration for assembly-line robots.

control system's transient response, so the position constant, K_p , velocity constant, K_v , and acceleration constant, K_a , can be used as specifications for a control system's steady-state errors. We will soon see that a wealth of information is contained within the specification of a static error constant.

For example, if a control system has the specification $K_v = 1000$, we can draw several conclusions:

1. The system is stable.
2. The system is of Type 1, since only Type 1 systems have K_v 's that are finite constants. Recall that $K_v = 0$ for Type 0 systems, whereas $K_v = \infty$ for Type 2 systems.
3. A ramp input is the test signal. Since K_v is specified as a finite constant, and the steady-state error for a ramp input is inversely proportional to K_v , we know the test input is a ramp.
4. The steady-state error between the input ramp and the output ramp is $1/K_v$ per unit of input slope.

Let us look at two examples that demonstrate analysis and design using static error constants.

Example 7.5

Interpreting the Steady-State Error Specification

PROBLEM: What information is contained in the specification $K_p = 1000$?

SOLUTION: The system is stable. The system is Type 0, since only a Type 0 system has a finite K_p . Type 1 and Type 2 systems have $K_p = \infty$. The input test signal is a step, since K_p is specified. Finally, the error per unit step is

$$e(\infty) = \frac{1}{1 + K_p} = \frac{1}{1 + 1000} = \frac{1}{1001} \quad (7.54)$$

Example 7.6

Gain Design to Meet a Steady-State Error Specification

PROBLEM: Given the control system in Figure 7.10, find the value of K so that there is 10% error in the steady state.

SOLUTION: Since the system is Type 1, the error stated in the problem must apply to a ramp input; only a ramp yields a finite error in a Type 1 system. Thus,

$$e(\infty) = \frac{1}{K_v} = 0.1 \quad (7.55)$$

Therefore,

$$K_v = 10 = \lim_{s \rightarrow 0} sG(s) = \frac{K \times 5}{6 \times 7 \times 8} \quad (7.56)$$

which yields

$$K = 672 \quad (7.57)$$

Applying the Routh-Hurwitz criterion, we see that the system is stable at this gain.

Although this gain meets the criteria for steady-state error and stability, it may not yield a desirable transient response. In Chapter 9 we will design feedback control systems to meet all three specifications.

Students who are using MATLAB should now run ch7 p2 in Appendix B. You will learn how to find the gain to meet a steady-state error specification using MATLAB. This exercise solves Example 7.6 using MATLAB.

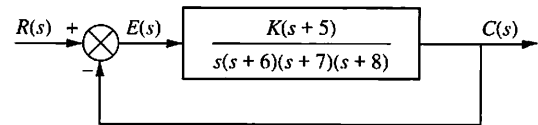

FIGURE 7.10 Feedback control system for Example 7.6

MATLAB
ML

Skill-Assessment Exercise 7.3

PROBLEM: A unity feedback system has the following forward transfer function:

$$G(s) = \frac{K(s+12)}{(s+14)(s+18)}$$

Find the value of K to yield a 10% error in the steady state.

ANSWER: $K = 189$

The complete solution is at www.wiley.com/college/nise.

WileyPLUS
WPCS
Control Solutions

TryIt 7.2

Use MATLAB, the Control System Toolbox, and the following statements to solve Skill-Assessment Exercise 7.3 and check the resulting system for stability.

```
numg=[1 12];
deng=poly([-14 -18]);
G=tf(numg,deng);
Kpdk=dcgain(G);
estep=0.1;
K=(1/estep-1)/Kpdk;
T=feedback(G,1);
poles=pole(T)
```

This example and exercise complete our discussion of unity feedback systems. In the remaining sections, we will deal with the steady-state errors for disturbances and the steady-state errors for feedback control systems in which the feedback is not unity.

7.5 Steady-State Error for Disturbances

Feedback control systems are used to compensate for disturbances or unwanted inputs that enter a system. The advantage of using feedback is that regardless of these disturbances, the system can be designed to follow the input with small or zero error, as we now demonstrate. Figure 7.11 shows a feedback control system with a disturbance, $D(s)$, injected between the controller and the plant. We now re-derive the expression for steady-state error with the disturbance included.

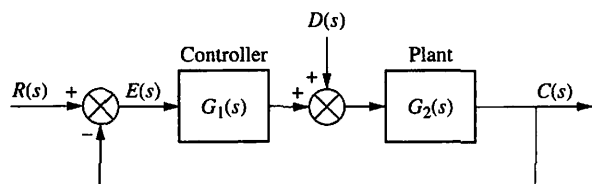

FIGURE 7.11 Feedback control system showing disturbance

The transform of the output is given by

$$C(s) = E(s)G_1(s)G_2(s) + D(s)G_2(s) \quad (7.58)$$

But

$$C(s) = R(s) - E(s) \quad (7.59)$$

Substituting Eq. (7.59) into Eq. (7.58) and solving for $E(s)$, we obtain

$$E(s) = \frac{1}{1 + G_1(s)G_2(s)} R(s) - \frac{G_2(s)}{1 + G_1(s)G_2(s)} D(s) \quad (7.60)$$

where we can think of $1/[1 + G_1(s)G_2(s)]$ as a transfer function relating $E(s)$ to $R(s)$ and $-G_2(s)/[1 + G_1(s)G_2(s)]$ as a transfer function relating $E(s)$ to $D(s)$.

To find the steady-state value of the error, we apply the final value theorem³ to Eq. (7.60) and obtain

$$e(\infty) = \lim_{s \rightarrow 0} sE(s) = \lim_{s \rightarrow 0} \frac{s}{1 + G_1(s)G_2(s)} R(s) - \lim_{s \rightarrow 0} \frac{sG_2(s)}{1 + G_1(s)G_2(s)} D(s) = e_R(\infty) + e_D(\infty) \quad (7.61)$$

where

$$e_R(\infty) = \lim_{s \rightarrow 0} \frac{s}{1 + G_1(s)G_2(s)} R(s)$$

and

$$e_D(\infty) = - \lim_{s \rightarrow 0} \frac{sG_2(s)}{1 + G_1(s)G_2(s)} D(s)$$

The first term, $e_R(\infty)$, is the steady-state error due to $R(s)$, which we have already obtained. The second term, $e_D(\infty)$, is the steady-state error due to the disturbance. Let us explore the conditions on $e_D(\infty)$ that must exist to reduce the error due to the disturbance.

At this point, we must make some assumptions about $D(s)$, the controller, and the plant. First we assume a step disturbance, $D(s) = 1/s$. Substituting this value into

³Remember that the final value theorem can be applied only if the system is stable, with the roots of $[1 + G_1(s)G_2(s)]$ in the left-half-plane.

the second term of Eq. (7.61), $e_D(\infty)$, the steady-state error component due to a step disturbance is found to be

$$e_D(\infty) = -\frac{1}{\lim_{s \rightarrow 0} \frac{1}{G_2(s)} + \lim_{s \rightarrow 0} G_1(s)} \quad (7.62)$$

This equation shows that the steady-state error produced by a step disturbance can be reduced by increasing the dc gain of $G_1(s)$ or decreasing the dc gain of $G_2(s)$.

This concept is shown in Figure 7.12, where the system of Figure 7.11 has been rearranged so that the disturbance, $D(s)$, is depicted as the input and the error, $E(s)$, as the output, with $R(s)$ set equal to zero. If we want to minimize the steady-state value of $E(s)$, shown as the output in Figure 7.12, we must either increase the dc gain of $G_1(s)$ so that a lower value of $E(s)$ will be fed back to match the steady-state value of $D(s)$, or decrease the dc value of $G_2(s)$, which then yields a smaller value of $e(\infty)$ as predicted by the feedback formula.

Let us look at an example and calculate the numerical value of the steady-state error that results from a disturbance.

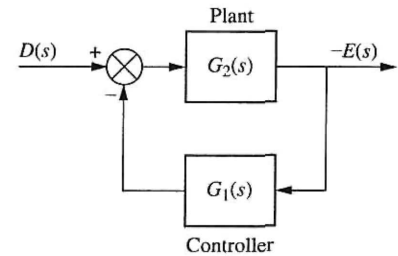

FIGURE 7.12 Figure 7.11 system rearranged to show disturbance as input and error as output, with $R(s) = 0$

Example 7.7

Steady-State Error Due to Step Disturbance

PROBLEM: Find the steady-state error component due to a step disturbance for the system of Figure 7.13.

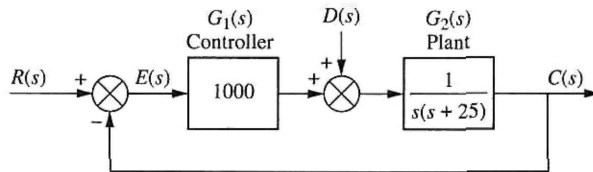

FIGURE 7.13 Feedback control system for Example 7.7

SOLUTION: The system is stable. Using Figure 7.12 and Eq. (7.62), we find

$$e_D(\infty) = -\frac{1}{\lim_{s \rightarrow 0} \frac{1}{G_2(s)} + \lim_{s \rightarrow 0} G_1(s)} = -\frac{1}{0 + 1000} = -\frac{1}{1000} \quad (7.63)$$

The result shows that the steady-state error produced by the step disturbance is inversely proportional to the dc gain of $G_1(s)$. The dc gain of $G_2(s)$ is infinite in this example.

Virtual Experiment 7.1 Steady-State Error

Put theory into practice finding the steady-state error of the Quanser Rotary Servo when subject to an input or a disturbance by simulating it in LabVIEW. This analysis becomes important when developing controllers for bottle labelling machines or robot joint control.

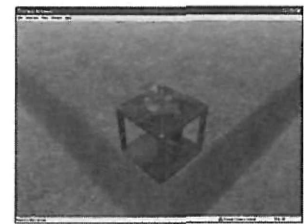

Virtual experiments are found on WileyPLUS.

Skill-Assessment Exercise 7.4

PROBLEM: Evaluate the steady-state error component due to a step disturbance for the system of Figure 7.14.

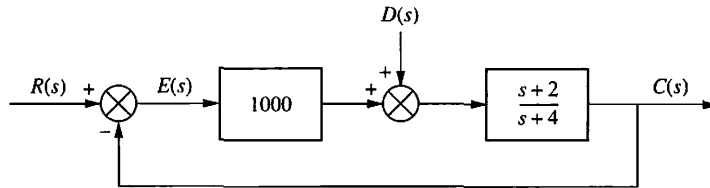

FIGURE 7.14 System for Skill-Assessment Exercise 7.4

ANSWER: $e_D(\infty) = -9.98 \times 10^{-4}$

The complete solution is at www.wiley.com/college/nise.

7.6 Steady-State Error for Nonunity Feedback Systems

Control systems often do not have unity feedback because of the compensation used to improve performance or because of the physical model for the system. The feedback path can be a pure gain other than unity or have some dynamic representation.

A general feedback system, showing the input transducer, $G_1(s)$, controller and plant, $G_2(s)$, and feedback, $H_1(s)$, is shown in Figure 7.15(a). Pushing the input transducer

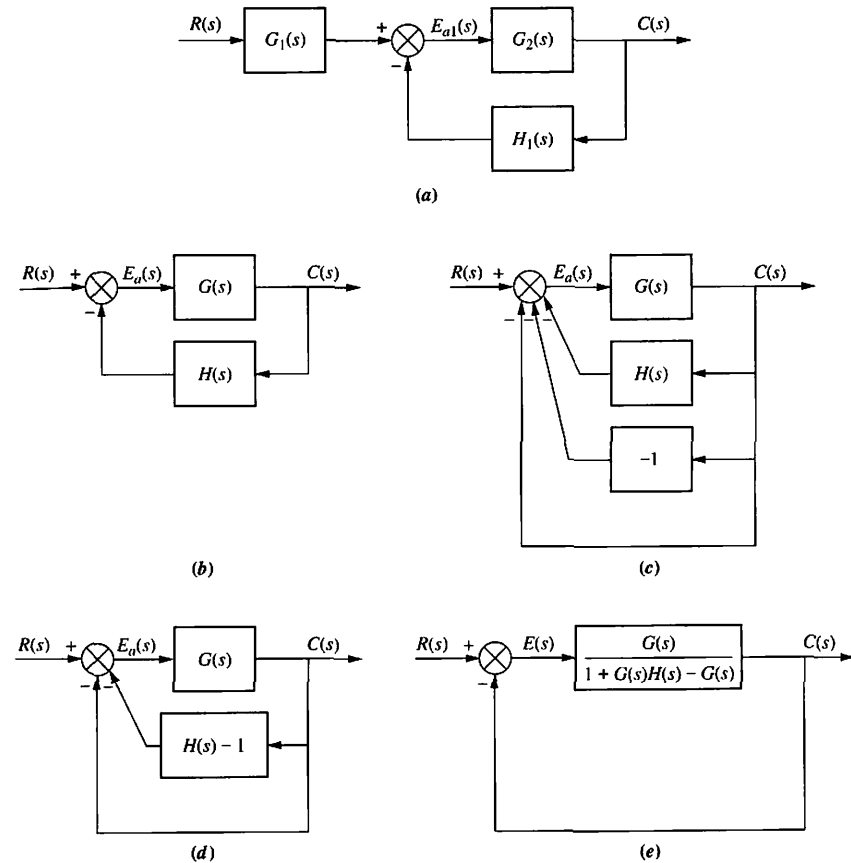

FIGURE 7.15 Forming an equivalent unity feedback system from a general nonunity feedback system

to the right past the summing junction yields the general nonunity feedback system shown in Figure 7.15(b), where $G(s) = G_1(s)G_2(s)$ and $H(s) = H_1(s)/G_1(s)$. Notice that unlike a unity feedback system, where $H(s) = 1$, the error is not the difference between the input and the output. For this case we call the signal at the output of the summing junction the *actuating signal*, $E_a(s)$. If $r(t)$ and $c(t)$ have the same units, we can find the steady-state error, $e(\infty) = r(\infty) - c(\infty)$. The first step is to show explicitly $E(s) = R(s) - C(s)$ on the block diagram.

Take the nonunity feedback control system shown in Figure 7.15(b) and form a unity feedback system by adding and subtracting unity feedback paths, as shown in Figure 7.15(c). This step requires that input and output units be the same. Next combine $H(s)$ with the negative unity feedback, as shown in Figure 7.15(d). Finally, combine the feedback system consisting of $G(s)$ and $[H(s) - 1]$, leaving an equivalent forward path and a unity feedback, as shown in Figure 7.15(e). Notice that the final figure shows $E(s) = R(s) - C(s)$ explicitly.

The following example summarizes the concepts of steady-state error, system type, and static error constants for nonunity feedback systems.

Example 7.8

Steady-State Error for Nonunity Feedback Systems

PROBLEM: For the system shown in Figure 7.16, find the system type, the appropriate error constant associated with the system type, and the steady-state error for a unit step input. Assume input and output units are the same.

SOLUTION: After determining that the system is indeed stable, one may impulsively declare the system to be Type 1. This may not be the case, since there is a nonunity feedback element, and the plant's actuating signal is not the difference between the input and the output.

The first step in solving the problem is to convert the system of Figure 7.16 into an equivalent unity feedback system. Using the equivalent forward transfer function of Figure 7.15(e) along with

$$G(s) = \frac{100}{s(s+10)} \quad (7.64)$$

and

$$H(s) = \frac{1}{(s+5)} \quad (7.65)$$

we find

$$G_e(s) = \frac{G(s)}{1 + G(s)H(s) - G(s)} = \frac{100(s+5)}{s^3 + 15s^2 - 50s - 400} \quad (7.66)$$

Thus, the system is Type 0, since there are no pure integrations in Eq. (7.66). The appropriate static error constant is then K_p , whose value is

$$K_p = \lim_{s \rightarrow 0} G_e(s) = \frac{100 \times 5}{-400} = -\frac{5}{4} \quad (7.67)$$

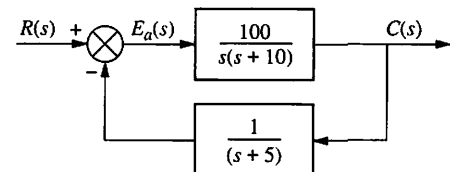

FIGURE 7.16 Nonunity feedback control system for Example 7.8

TryIt 7.3

Use MATLAB, the Control System Toolbox, and the following statements to find $G_e(s)$ in Example 7.8.

```
G=zpk([1],[0 -10],100);
H=zpk([1,-5],1);
Ge=feedback...
(G,(H-1));
'Ge(s)'
Ge=tf(Ge)
T=feedback(Ge,1);
'Poles of T(s)'
pole(T)
```

The steady-state error, $e(\infty)$, is

$$e(\infty) = \frac{1}{1 + K_p} = \frac{1}{1 - (5/4)} = -4 \quad (7.68)$$

The negative value for steady-state error implies that the output step is larger than the input step.

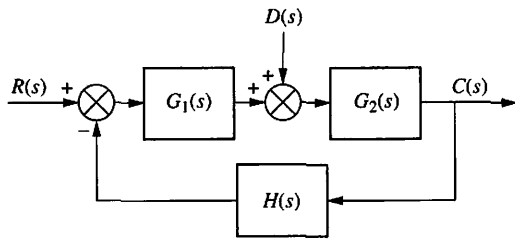

FIGURE 7.17 Nonunity feedback control system with disturbance

To continue our discussion of steady-state error for systems with nonunity feedback, let us look at the general system of Figure 7.17, which has both a disturbance and nonunity feedback. We will derive a general equation for the steady-state error and then determine the parameters of the system in order to drive the error to zero for step inputs and step disturbances.⁴

The steady-state error for this system, $e(\infty) = r(\infty) - c(\infty)$, is

$$e(\infty) = \lim_{s \rightarrow 0} sE(s) = \lim_{s \rightarrow 0} s \left\{ \left[1 - \frac{G_1(s)G_2(s)}{1 + G_1(s)G_2(s)H(s)} \right] R(s) - \left[\frac{G_2(s)}{1 + G_1(s)G_2(s)H(s)} D(s) \right] \right\} \quad (7.69)$$

Now limiting the discussion to step inputs and step disturbances, where $R(s) = D(s) = 1/s$, Eq. (7.69) becomes

$$e(\infty) = \lim_{s \rightarrow 0} sE(s) = \left\{ \left[1 - \frac{\lim_{s \rightarrow 0} [G_1(s)G_2(s)]}{\lim_{s \rightarrow 0} [1 + G_1(s)G_2(s)H(s)]} \right] - \left[\frac{\lim_{s \rightarrow 0} G_2(s)}{\lim_{s \rightarrow 0} [1 + G_1(s)G_2(s)H(s)]} \right] \right\} \quad (7.70)$$

For zero error,

$$\frac{\lim_{s \rightarrow 0} [G_1(s)G_2(s)]}{\lim_{s \rightarrow 0} [1 + G_1(s)G_2(s)H(s)]} = 1 \quad \text{and} \quad \frac{\lim_{s \rightarrow 0} G_2(s)}{\lim_{s \rightarrow 0} [1 + G_1(s)G_2(s)H(s)]} = 0 \quad (7.71)$$

The two equations in Eq. (7.71) can always be satisfied if (1) the system is stable, (2) $G_1(s)$ is a Type 1 system, (3) $G_2(s)$ is a Type 0 system, and (4) $H(s)$ is a Type 0 system with a dc gain of unity.

To conclude this section, we discuss finding the steady-state value of the actuating signal, $E_{a1}(s)$, in Figure 7.15(a). For this task there is no restriction that the input and output units be the same, since we are finding the steady-state difference between signals at the summing junction, which do have the same units.⁵ The steady-state

⁴ Details of the derivation are included as a problem at the end of this chapter.

⁵ For clarity, steady-state error is the steady-state difference between the input and the output. Steady-state actuating signal is the steady-state difference at the output of the summing junction. In questions asking for steady-state error in problems, examples, and skill-assessment exercises, it will be assumed that input and output units are the same.

actuating signal for Figure 7.15(a) is

$$e_{a1}(\infty) = \lim_{s \rightarrow 0} \frac{sR(s)G_1(s)}{1 + G_2(s)H_1(s)} \quad (7.72)$$

The derivation is left to the student in the problem set at the end of this chapter.

Example 7.9

Steady-State Actuating Signal for Nonunity Feedback Systems

PROBLEM: Find the steady-state actuating signal for the system of Figure 7.16 for a unit step input. Repeat for a unit ramp input.

SOLUTION: Use Eq. (7.72) with $R(s) = 1/s$, a unit step input, $G_1(s) = 1$, $G_2(s) = 100/[s(s+10)]$, and $H_1(s) = 1/(s+5)$. Also, realize that $e_{a1}(\infty) = e_a(\infty)$, since $G_1(s) = 1$. Thus,

$$e_a(\infty) = \lim_{s \rightarrow 0} \frac{s \left(\frac{1}{s} \right)}{1 + \left(\frac{100}{s(s+10)} \right) \left(\frac{1}{s+5} \right)} = 0 \quad (7.73)$$

Now use Eq. (7.72) with $R(s) = 1/s^2$, a unit ramp input, and obtain

$$e_a(\infty) = \lim_{s \rightarrow 0} \frac{s \left(\frac{1}{s^2} \right)}{1 + \left(\frac{100}{s(s+10)} \right) \left(\frac{1}{s+5} \right)} = \frac{1}{2} \quad (7.74)$$

Skill-Assessment Exercise 7.5

PROBLEM:

- Find the steady-state error, $e(\infty) = r(\infty) - c(\infty)$, for a unit step input given the nonunity feedback system of Figure 7.18. Repeat for a unit ramp input. Assume input and output units are the same.
- Find the steady-state actuating signal, $e_a(\infty)$, for a unit step input given the nonunity feedback system of Figure 7.18. Repeat for a unit ramp input.

ANSWERS:

- $e_{\text{step}}(\infty) = 3.846 \times 10^{-2}$; $e_{\text{ramp}}(\infty) = \infty$
- For a unit step input, $e_a(\infty) = 3.846 \times 10^{-2}$; for a unit ramp input, $e_a(\infty) = \infty$

The complete solution is at www.wiley.com/college/nise.

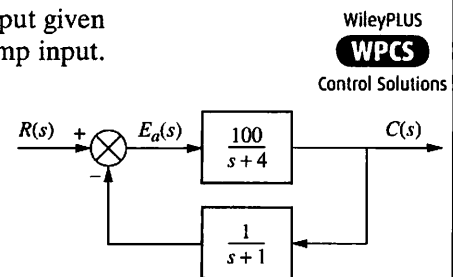

FIGURE 7.18 Nonunity feedback system for Skill-Assessment Exercise 7.5

WileyPLUS
WPCS

Control Solutions

In this section, we have applied steady-state error analysis to nonunity feedback systems. When nonunity feedback is present, the plant's actuating signal is not

the actual error or difference between the input and the output. With nonunity feedback we may choose to (1) find the steady-state error for systems where the input and output units are the same or (2) find the steady-state actuating signal.

We also derived a general expression for the steady-state error of a nonunity feedback system with a disturbance. We used this equation to determine the attributes of the subsystems so that there was zero error for step inputs and step disturbances.

Before concluding this chapter, we will discuss a topic that is not only significant for steady-state errors but generally useful throughout the control systems design process.

7.7 Sensitivity

During the design process, the engineer may want to consider the extent to which changes in system parameters affect the behavior of a system. Ideally, parameter changes due to heat or other causes should not appreciably affect a system's performance. The degree to which changes in system parameters affect system transfer functions, and hence performance, is called *sensitivity*. A system with zero sensitivity (that is, changes in the system parameters have no effect on the transfer function) is ideal. The greater the sensitivity, the less desirable the effect of a parameter change.

For example, assume the function $F = K/(K + a)$. If $K = 10$ and $a = 100$, then $F = 0.091$. If parameter a triples to 300, then $F = 0.032$. We see that a fractional change in parameter a of $(300 - 100)/100 = 2$ (a 200% change), yields a change in the function F of $(0.032 - 0.091)/0.091 = -0.65$ (-65% change). Thus, the function F has reduced sensitivity to changes in parameter a . As we proceed, we will see that another advantage of feedback is that in general it affords reduced sensitivity to parameter changes.

Based upon the previous discussion, let us formalize a definition of sensitivity: *Sensitivity* is the ratio of the fractional change in the function to the fractional change in the parameter as the fractional change of the parameter approaches zero. That is,

$$\begin{aligned} S_{F:P} &= \lim_{\Delta P \rightarrow 0} \frac{\text{Fractional change in the function, } F}{\text{Fractional change in the parameter, } P} \\ &= \lim_{\Delta P \rightarrow 0} \frac{\Delta F/F}{\Delta P/P} \\ &= \lim_{\Delta P \rightarrow 0} \frac{P \Delta F}{F \Delta P} \end{aligned}$$

which reduces to

$$S_{F:P} = \frac{P}{F} \frac{\delta F}{\delta P} \quad (7.75)$$

Let us now apply the definition, first to a closed-loop transfer function and then to the steady-state error.

Example 7.10

Sensitivity of a Closed-Loop Transfer Function

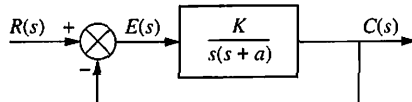

FIGURE 7.19 Feedback control system for Examples 7.10 and 7.11

PROBLEM: Given the system of Figure 7.19, calculate the sensitivity of the closed-loop transfer function to changes in the parameter a . How would you reduce the sensitivity?

SOLUTION: The closed-loop transfer function is

$$T(s) = \frac{K}{s^2 + as + K} \quad (7.76)$$

Using Eq. (7.75), the sensitivity is given by

$$S_{T:a} = \frac{a}{T} \frac{\delta T}{\delta a} = \frac{a}{\left(\frac{K}{s^2 + as + K}\right)} \left(\frac{-Ks}{(s^2 + as + K)^2}\right) = \frac{-as}{s^2 + as + K} \quad (7.77)$$

which is, in part, a function of the value of s . For any value of s , however, an increase in K reduces the sensitivity of the closed-loop transfer function to changes in the parameter a .

Example 7.11

Sensitivity of Steady-State Error with Ramp Input

PROBLEM: For the system of Figure 7.19, find the sensitivity of the steady-state error to changes in parameter K and parameter a with ramp inputs.

SOLUTION: The steady-state error for the system is

$$e(\infty) = \frac{1}{K_v} = \frac{a}{K} \quad (7.78)$$

The sensitivity of $e(\infty)$ to changes in parameter a is

$$S_{e:a} = \frac{a}{e} \frac{\delta e}{\delta a} = \frac{a}{a/K} \left[\frac{1}{K}\right] = 1 \quad (7.79)$$

The sensitivity of $e(\infty)$ to changes in parameter K is

$$S_{e:K} = \frac{K}{e} \frac{\delta e}{\delta K} = \frac{K}{a/K} \left[\frac{-a}{K^2}\right] = -1 \quad (7.80)$$

Thus, changes in either parameter a or parameter K are directly reflected in $e(\infty)$, and there is no reduction or increase in sensitivity. The negative sign in Eq. (7.80) indicates a decrease in $e(\infty)$ for an increase in K . Both of these results could have been obtained directly from Eq. (7.78) since $e(\infty)$ is directly proportional to parameter a and inversely proportional to parameter K .

Example 7.12

Sensitivity of Steady-State Error with Step Input

PROBLEM: Find the sensitivity of the steady-state error to changes in parameter K and parameter a for the system shown in Figure 7.20 with a step input.

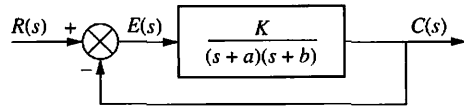

FIGURE 7.20 Feedback control system for Example 7.12

TryIt 7.4

Use MATLAB, the Symbolic Math Toolbox, and the following statements to find $S_{e:a}$ in Example 7.12.

```
syms K a b s
G=K/((s+a)*(s+b));
Kp=subs(G,s,0);
e=1/(1+Kp);
Sea=(a/e)*diff(e,a);
Sea=simple(Sea);
'Sea'
pretty(Sea)
```

SOLUTION: The steady-state error for this Type 0 system is

$$e(\infty) = \frac{1}{1 + K_p} = \frac{1}{1 + \frac{K}{ab}} = \frac{ab}{ab + K} \quad (7.81)$$

The sensitivity of $e(\infty)$ to changes in parameter a is

$$S_{e:a} = \frac{a}{e} \frac{\delta e}{\delta a} = \frac{a}{\left(\frac{ab}{ab + K}\right)} \frac{(ab + K)b - ab^2}{(ab + K)^2} = \frac{K}{ab + K} \quad (7.82)$$

The sensitivity of $e(\infty)$ to changes in parameter K is

$$S_{e:K} = \frac{K}{e} \frac{\delta e}{\delta K} = \frac{K}{\left(\frac{ab}{ab + K}\right)} \frac{-ab}{(ab + K)^2} = \frac{-K}{ab + K} \quad (7.83)$$

Equations (7.82) and (7.83) show that the sensitivity to changes in parameter K and parameter a is less than unity for positive a and b . Thus, feedback in this case yields reduced sensitivity to variations in both parameters.

Skill-Assessment Exercise 7.6

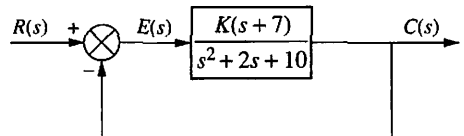

FIGURE 7.21 System for Skill-Assessment Exercise 7.6

PROBLEM: Find the sensitivity of the steady-state error to changes in K for the system of Figure 7.21.

ANSWER: $S_{e:k} = \frac{-7K}{10 + 7K}$

The complete solution is at www.wiley.com/college/nise.

In this section, we defined sensitivity and showed that in some cases feedback reduces the sensitivity of a system's steady-state error to changes in system parameters. The concept of sensitivity can be applied to other measures of control system performance, as well; it is not limited to the sensitivity of the steady-state error performance.

7.8 Steady-State Error for Systems in State Space

Up to this point, we have evaluated the steady-state error for systems modeled as transfer functions. In this section, we will discuss how to evaluate the steady-state error for systems represented in state space. Two methods for calculating the steady-state error will be covered: (1) analysis via final value theorem and (2) analysis via input substitution. We will consider these methods individually.

Analysis via Final Value Theorem

A single-input, single-output system represented in state space can be analyzed for steady-state error using the final value theorem and the closed-loop transfer

function, Eq. (3.73), derived in terms of the state-space representation. Consider the closed-loop system represented in state space:

$$\dot{\mathbf{x}} = \mathbf{A}\mathbf{x} + \mathbf{B}r \quad (7.84a)$$

$$y = \mathbf{C}\mathbf{x} \quad (7.84b)$$

The Laplace transform of the error is

$$E(s) = R(s) - Y(s) \quad (7.85)$$

But

$$Y(s) = R(s)T(s) \quad (7.86)$$

where $T(s)$ is the closed-loop transfer function. Substituting Eq. (7.86) into (7.85), we obtain

$$E(s) = R(s)[1 - T(s)] \quad (7.87)$$

Using Eq. (3.73) for $T(s)$, we find

$$E(s) = R(s)[1 - \mathbf{C}(s\mathbf{I} - \mathbf{A})^{-1}\mathbf{B}] \quad (7.88)$$

Applying the final value theorem, we have

$$\lim_{s \rightarrow 0} sE(s) = \lim_{s \rightarrow 0} sR(s)[1 - \mathbf{C}(s\mathbf{I} - \mathbf{A})^{-1}\mathbf{B}] \quad (7.89)$$

Let us apply the result to an example.

Example 7.13

Steady-State Error Using the Final Value Theorem

PROBLEM: Evaluate the steady-state error for the system described by Eqs. (7.90) for unit step and unit ramp inputs. Use the final value theorem.

$$\mathbf{A} = \begin{bmatrix} -5 & 1 & 0 \\ 0 & -2 & 1 \\ 20 & -10 & 1 \end{bmatrix}; \quad \mathbf{B} = \begin{bmatrix} 0 \\ 0 \\ 1 \end{bmatrix}; \quad \mathbf{C} = [-1 \quad 1 \quad 0] \quad (7.90)$$

SOLUTION: Substituting Eqs. (7.90) into (7.89), we obtain

$$\begin{aligned} e(\infty) &= \lim_{s \rightarrow 0} sR(s) \left(1 - \frac{s+4}{s^3 + 6s^2 + 13s + 20} \right) \\ &= \lim_{s \rightarrow 0} sR(s) \left(\frac{s^3 + 6s^2 + 12s + 16}{s^3 + 6s^2 + 13s + 20} \right) \end{aligned} \quad (7.91)$$

For a unit step, $R(s) = 1/s$, and $e(\infty) = 4/5$. For a unit ramp, $R(s) = 1/s^2$, and $e(\infty) = \infty$. Notice that the system behaves like a Type 0 system.

TryIt 7.5

Use MATLAB, the Symbolic Math Toolbox, and the following statements to find the steady-state error for a step input to the system of Example 7.13.

```
syms s
A=[-5 1 0
    0 -2 1
    20 -10 1];
B=[0;0;1];
C=[-1 1 0];
I=[1 0 0
    0 1 0
    0 0 1];
E=(1/s)*[1-C*...
  [(s*I-A)^-1]*B];
%New command:
%subs(X,old,new):
%Replace old in ...
%X(old) with new.
error=subs(s*E,s,0)
```

Analysis via Input Substitution

Another method for steady-state analysis avoids taking the inverse of $(s\mathbf{I} - \mathbf{A})$ and can be expanded to multiple-input, multiple-output systems; it substitutes the input along with an assumed solution into the state equations (*Hostetter, 1989*). We will derive the results for unit step and unit ramp inputs.

Step Inputs. Given the state Eqs. (7.84), if the input is a unit step where $r = 1$, a steady-state solution, \mathbf{x}_{ss} , for \mathbf{x} , is

$$\mathbf{x}_{ss} = \begin{bmatrix} V_1 \\ V_2 \\ \vdots \\ V_n \end{bmatrix} = \mathbf{V} \quad (7.92)$$

where V_i is constant. Also,

$$\dot{\mathbf{x}}_{ss} = \mathbf{0} \quad (7.93)$$

Substituting $r = 1$, a unit step, along with Eqs. (7.92) and (7.93), into Eqs. (7.84) yields

$$\mathbf{0} = \mathbf{A}\mathbf{V} + \mathbf{B} \quad (7.94a)$$

$$y_{ss} = \mathbf{C}\mathbf{V} \quad (7.94b)$$

where y_{ss} is the steady-state output. Solving for \mathbf{V} yields

$$\mathbf{V} = -\mathbf{A}^{-1}\mathbf{B} \quad (7.95)$$

But the steady-state error is the difference between the steady-state input and the steady-state output. The final result for the steady-state error for a unit step input into a system represented in state space is

$$e(\infty) = 1 - y_{ss} = 1 - \mathbf{C}\mathbf{V} = 1 + \mathbf{C}\mathbf{A}^{-1}\mathbf{B} \quad (7.96)$$

Ramp Inputs. For unit ramp inputs, $r = t$, a steady-state solution for \mathbf{x} is

$$\mathbf{x}_{ss} = \begin{bmatrix} V_1 t + W_1 \\ V_2 t + W_2 \\ \vdots \\ V_n t + W_n \end{bmatrix} = \mathbf{V}t + \mathbf{W} \quad (7.97)$$

where V_i and W_i are constants. Hence,

$$\dot{\mathbf{x}}_{ss} = \begin{bmatrix} V_1 \\ V_2 \\ \vdots \\ V_n \end{bmatrix} = \mathbf{V} \quad (7.98)$$

Substituting $r = t$ along with Eqs. (7.97) and (7.98) into Eqs. (7.84) yields

$$\mathbf{V} = \mathbf{A}(\mathbf{V}t + \mathbf{W}) + \mathbf{B}t \quad (7.99a)$$

$$y_{ss} = \mathbf{C}(\mathbf{V}t + \mathbf{W}) \quad (7.99b)$$

In order to balance Eq. (7.99a), we equate the matrix coefficients of t , $\mathbf{A}\mathbf{V} = -\mathbf{B}$, or

$$\mathbf{V} = -\mathbf{A}^{-1}\mathbf{B} \quad (7.100)$$

Equating constant terms in Eq. (7.99a), we have $\mathbf{A}\mathbf{W} = \mathbf{V}$, or

$$\mathbf{W} = \mathbf{A}^{-1}\mathbf{V} \quad (7.101)$$

Substituting Eqs. (7.100) and (7.101) into (7.99b) yields

$$y_{ss} = \mathbf{C}[-\mathbf{A}^{-1}\mathbf{B}t + \mathbf{A}^{-1}(-\mathbf{A}^{-1}\mathbf{B})] = -\mathbf{C}[\mathbf{A}^{-1}\mathbf{B}t + (\mathbf{A}^{-1})^2\mathbf{B}] \quad (7.102)$$

The steady-state error is therefore

$$e(\infty) = \lim_{t \rightarrow \infty} (t - y_{ss}) = \lim_{t \rightarrow \infty} [(1 + \mathbf{C}\mathbf{A}^{-1}\mathbf{B})t + \mathbf{C}(\mathbf{A}^{-1})^2\mathbf{B}] \quad (7.103)$$

Notice that in order to use this method, \mathbf{A}^{-1} must exist. That is, $\det \mathbf{A} \neq 0$.

We now demonstrate the use of Eqs. (7.96) and (7.103) to find the steady-state error for step and ramp inputs.

Example 7.14

Steady-State Error Using Input Substitution

PROBLEM: Evaluate the steady-state error for the system described by the three equations in Eq. (7.90) for unit step and unit ramp inputs. Use input substitution.

SOLUTION: For a unit step input, the steady-state error given by Eq. (7.96) is

$$e(\infty) = 1 + \mathbf{C}\mathbf{A}^{-1}\mathbf{B} = 1 - 0.2 = 0.8 \quad (7.104)$$

where \mathbf{C} , \mathbf{A} , and \mathbf{B} are as follows:

$$\mathbf{A} = \begin{bmatrix} -5 & 1 & 0 \\ 0 & -2 & 1 \\ 20 & -10 & 1 \end{bmatrix}; \quad \mathbf{B} = \begin{bmatrix} 0 \\ 0 \\ 1 \end{bmatrix}; \quad \mathbf{C} = [-1 \quad 1 \quad 0] \quad (7.105)$$

For a ramp input, using Eq. (7.103), we have

$$e(\infty) = \lim_{t \rightarrow \infty} [(1 + \mathbf{C}\mathbf{A}^{-1}\mathbf{B})t + \mathbf{C}(\mathbf{A}^{-1})^2\mathbf{B}] = \lim_{t \rightarrow \infty} (0.8t + 0.08) = \infty \quad (7.106)$$

Skill-Assessment Exercise 7.7

WileyPLUS
WPCS
 Control Solutions

PROBLEM: Find the steady-state error for a step input given the system represented in state space below. Calculate the steady-state error using both the final value theorem and input substitution methods.

$$\mathbf{A} = \begin{bmatrix} 0 & 1 \\ -3 & -6 \end{bmatrix}; \quad \mathbf{B} = \begin{bmatrix} 0 \\ 1 \end{bmatrix}; \quad \mathbf{C} = [1 \quad 1]$$

ANSWER:

$$e_{\text{step}}(\infty) = \frac{2}{3}$$

The complete solution is at www.wiley.com/college/nise.

In this chapter, we covered the evaluation of steady-state error for systems represented by transfer functions as well as systems represented in state space. For systems represented in state space, two methods were presented: (1) final value theorem and (2) input substitution.

Case Studies

Antenna Control: Steady-State Error Design via Gain

Design
D

This chapter showed how to find steady-state errors for step, ramp, and parabolic inputs to a closed-loop feedback control system. We also learned how to evaluate the gain to meet a steady-state error requirement. This ongoing case study uses our antenna azimuth position control system to summarize the concepts.

PROBLEM: For the antenna azimuth position control system shown on the front endpapers, Configuration 1,

- Find the steady-state error in terms of gain, K , for step, ramp, and parabolic inputs.
- Find the value of gain, K , to yield a 10% error in the steady state.

SOLUTION:

- The simplified block diagram for the system is shown on the front endpapers. The steady-state error is given by

$$e(\infty) = \lim_{s \rightarrow 0} sE(s) = \lim_{s \rightarrow 0} \frac{sR(s)}{1 + G(s)} \quad (7.107)$$

From the block diagram, after pushing the potentiometer to the right past the summing junction, the equivalent forward transfer function is

$$G(s) = \frac{6.63K}{s(s + 1.71)(s + 100)} \quad (7.108)$$

To find the steady-state error for a step input, use $R(s) = 1/s$ along with Eq. (7.108), and substitute these in Eq. (7.107). The result is $e(\infty) = 0$.

To find the steady-state error for a ramp input, use $R(s) = 1/s^2$ along with Eq. (7.108), and substitute these in Eq. (7.107). The result is $e(\infty) = 25.79/K$.

To find the steady-state error for a parabolic input, use $R(s) = 1/s^3$ along with Eq. (7.108), and substitute these in Eq. (7.107). The result is $e(\infty) = \infty$.

- b. Since the system is Type 1, a 10% error in the steady-state must refer to a ramp input. This is the only input that yields a finite, nonzero error. Hence, for a unit ramp input,

$$e(\infty) = 0.1 = \frac{1}{K_v} = \frac{(1.71)(100)}{6.63K} = \frac{25.79}{K} \quad (7.109)$$

from which $K = 257.9$. You should verify that the value of K is within the range of gains that ensures system stability. In the antenna control case study in the last chapter, the range of gain for stability was found to be $0 < K < 2623.29$. Hence, the system is stable for a gain of 257.9.

CHALLENGE: You are now given a problem to test your knowledge of this chapter's objectives: Referring to the antenna azimuth position control system shown on the front endpapers, Configuration 2, do the following:

- Find the steady-state errors in terms of gain, K , for step, ramp, and parabolic inputs.
- Find the value of gain, K , to yield a 20% error in the steady state.

Video Laser Disc Recorder: Steady-State Error Design via Gain

Design
D

As a second case study, let us look at a video laser disc focusing system for recording.

PROBLEM: In order to record on a video laser disc, a $0.5\mu\text{m}$ laser spot must be focused on the recording medium to burn pits that represent the program material. The small laser spot requires that the focusing lens be positioned to an accuracy of $\pm 0.1\mu\text{m}$. A model of the feedback control system for the focusing lens is shown in Figure 7.22.

The detector detects the distance between the focusing lens and the video disc by measuring the degree of focus as shown in Figure 7.23(a). Laser light reflected from the disc, D , is split by beam splitters B_1 and B_2 and focused behind aperture A . The remainder is reflected by the mirror and focuses in front of aperture A . The amount of light of each beam that passes through the aperture depends on how far the beam's focal point is from the aperture. Each side of the split photodiode, P , measures the intensity of each beam. Thus, as the disc's distance from the recording

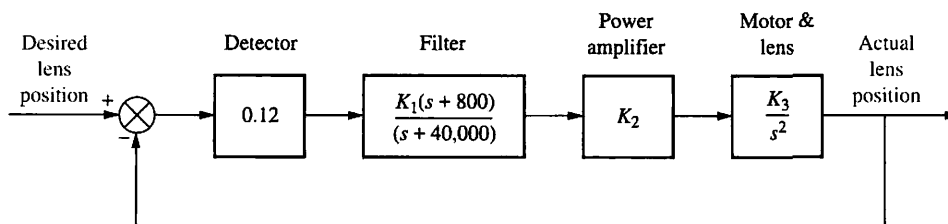
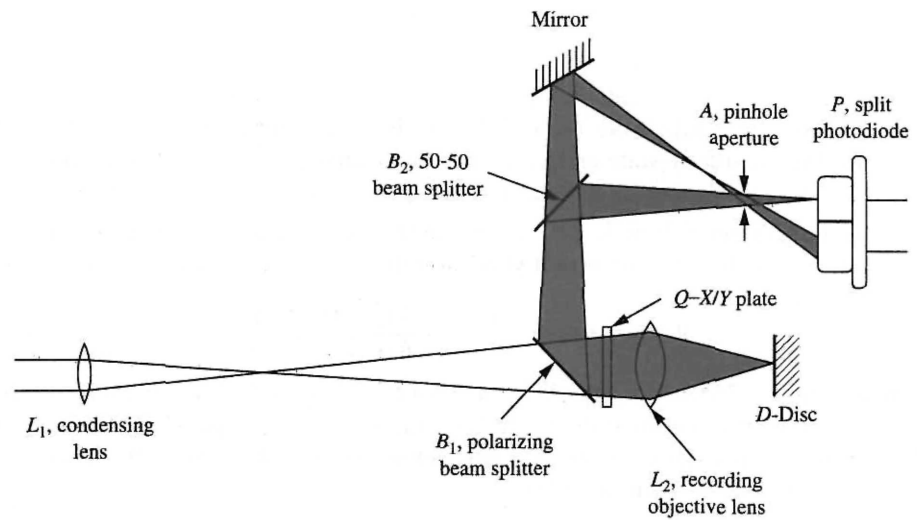
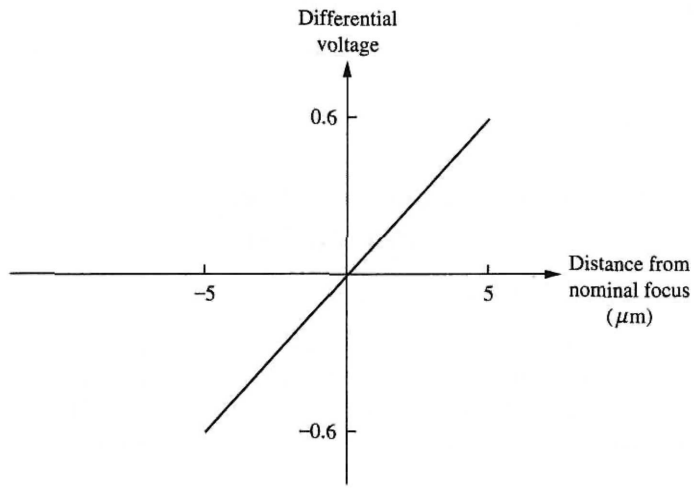

FIGURE 7.22 Video laser disc recording: control system for focusing write beam



(a)



(b)

FIGURE 7.23 Video disc laser recording: **a.** focus detector optics; **b.** linearized transfer function for focus detector

objective lens changes, so does the focal point of each beam. As a result, the relative voltage detected by each part of the split photodiode changes. When the beam is out of focus, one side of the photodiode outputs a larger voltage. When the beam is in focus, the voltage outputs from both sides of the photodiode are equal.

A simplified model for the detector is a straight line relating the differential voltage output from the two elements to the distance of the laser disc from nominal focus. A linearized plot of the detector input-output relationship is shown in Figure 7.23(b) (Isailović, 1985). Assume that a warp on the disc yields a worst-case disturbance in the focus of $10\tau^2 \mu\text{m}$. Find the value of $K_1K_2K_3$ in order to meet the focusing accuracy required by the system.

SOLUTION: Since the system is Type 2, it can respond to parabolic inputs with finite error. We can assume that the disturbance has the same effect as an input of $10t^2 \mu\text{m}$. The Laplace transform of $10t^2$ is $20/s^3$, or 20 units greater than the unit acceleration used to derive the general equation of the error for a parabolic input. Thus, $e(\infty) = 20/K_a$. But $K_a = \lim_{s \rightarrow 0} s^2 G(s)$.

From Figure 7.22, $K_a = 0.0024K_1K_2K_3$. Also, from the problem statement, the error must be no greater than $0.1 \mu\text{m}$. Hence, $e(\infty) = 8333.33/K_1K_2K_3 = 0.1$. Thus, $K_1K_2K_3 \geq 83333.3$, and the system is stable.

CHALLENGE: You are now given a problem to test your knowledge of this chapter's objectives: Given the video laser disc recording system whose block diagram is shown in Figure 7.24, do the following:

- If the focusing lens needs to be positioned to an accuracy of $\pm 0.005 \mu\text{m}$, find the value of $K_1K_2K_3$ if the warp on the disc yields a worst-case disturbance in the focus of $15t^2 \mu\text{m}$.
- Use the Routh-Hurwitz criterion to show that the system is stable when the conditions of **a.** are met.
- Use MATLAB to show that the system is stable when the conditions of **a.** are met.

MATLAB
ML

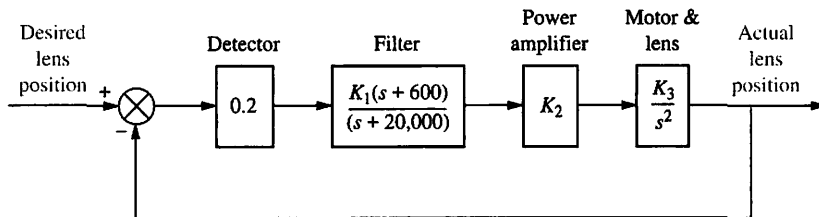

FIGURE 7.24 Video laser disc recording focusing system

Summary

This chapter covered the analysis and design of feedback control systems for steady-state errors. The steady-state errors studied resulted strictly from the system configuration. On the basis of a system configuration and a group of selected test signals, namely steps, ramps, and parabolas, we can analyze or design for the system's steady-state error performance. The greater the number of pure integrations a system has in the forward path, the higher the degree of accuracy, assuming the system is stable.

The steady-state errors depend upon the type of test input. Applying the final value theorem to stable systems, the steady-state error for unit step inputs is

$$e(\infty) = \frac{1}{1 + \lim_{s \rightarrow 0} G(s)} \quad (7.110)$$

The steady-state error for ramp inputs of unit velocity is

$$e(\infty) = \frac{1}{\lim_{s \rightarrow 0} sG(s)} \quad (7.111)$$

and for parabolic inputs of unit acceleration, it is

$$e(\infty) = \frac{1}{\lim_{s \rightarrow 0} s^2 G(s)} \quad (7.112)$$

The terms taken to the limit in Eqs. (7.110) through (7.112) are called *static error constants*. Beginning with Eq. (7.110), the terms in the denominator taken to the limit are called the *position constant*, *velocity constant*, and *acceleration constant*, respectively. The static error constants are the steady-state error specifications for control systems. By specifying a static error constant, one is stating the number of pure integrations in the forward path, the test signal used, and the expected steady-state error.

Another definition covered in this chapter was that of *system type*. The system type is the number of pure integrations in the forward path, assuming a unity feedback system. Increasing the system type decreases the steady-state error as long as the system remains stable.

Since the steady-state error is, for the most part, inversely proportional to the static error constant, the larger the static error constant, the smaller the steady-state error. Increasing system gain increases the static error constant. Thus, in general, increasing system gain decreases the steady-state error as long as the system remains stable.

Nonunity feedback systems were handled by deriving an equivalent unity feedback system whose steady-state error characteristics followed all previous development. The method was restricted to systems where input and output units are the same.

We also saw how feedback decreases a system's steady-state error caused by disturbances. With feedback, the effect of a disturbance can be reduced by system gain adjustments.

Finally, for systems represented in state space, we calculated the steady-state error using the final value theorem and input substitution methods.

In the next chapter, we will examine the root locus, a powerful tool for the analysis and design of control systems.

Review Questions

1. Name two sources of steady-state errors.
2. A position control, tracking with a constant difference in velocity, would yield how much position error in the steady state?
3. Name the test inputs used to evaluate steady-state error.
4. How many integrations in the forward path are required in order for there to be zero steady-state error for each of the test inputs listed in Question 3?
5. Increasing system gain has what effect upon the steady-state error?
6. For a step input, the steady-state error is approximately the reciprocal of the static error constant if what condition holds true?
7. What is the exact relationship between the static error constants and the steady-state errors for ramp and parabolic inputs?
8. What information is contained in the specification $K_p = 10,000$?
9. Define *system type*.

10. The forward transfer function of a control system has three poles at -1 , -2 , and -3 . What is the system type?
11. What effect does feedback have upon disturbances?
12. For a step input disturbance at the input to the plant, describe the effect of controller and plant gain upon minimizing the effect of the disturbance.
13. Is the forward-path actuating signal the system error if the system has nonunity feedback?
14. How are nonunity feedback systems analyzed and designed for steady-state errors?
15. Define, in words, *sensitivity* and describe the goal of feedback-control-system engineering as it applies to sensitivity.
16. Name two methods for calculating the steady-state error for systems represented in state space.

Problems

1. For the unity feedback system shown in Figure P7.1, where

$$G(s) = \frac{450(s+8)(s+12)(s+15)}{s(s+38)(s^2+2s+28)}$$

find the steady-state errors for the following test inputs: $25u(t)$, $37tu(t)$, $47t^2u(t)$. [Section: 7.2]

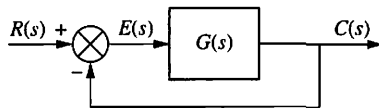

FIGURE P7.1

2. Figure P7.2 shows the ramp input $r(t)$ and the output $c(t)$ of a system. Assuming the output's steady state can be approximated by a ramp, find [Section: 7.1]
 - a. the steady-state error;
 - b. the steady-state error if the input becomes $r(t) = tu(t)$.

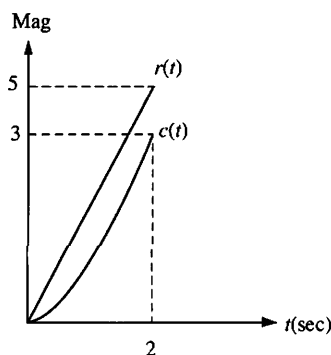

FIGURE P7.2

3. For the unity feedback system shown in Figure P7.1, where

$$G(s) = \frac{60(s+3)(s+4)(s+8)}{s^2(s+6)(s+17)}$$

find the steady-state error if the input is $80t^2u(t)$. [Section: 7.2]

4. For the system shown in Figure P7.3, what steady-state error can be expected for the following test inputs: $15u(t)$, $15tu(t)$, $15t^2u(t)$. [Section: 7.2]

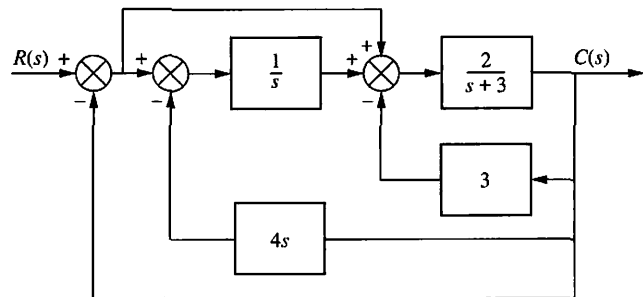

FIGURE P7.3

5. For the unity feedback system shown in Figure P7.1, where

$$G(s) = \frac{500}{(s+24)(s^2+8s+14)}$$

find the steady-state error for inputs of $30u(t)$, $70tu(t)$, and $81t^2u(t)$. [Section: 7.3]

6. An input of $25t^3u(t)$ is applied to the input of a Type 3 unity feedback system, as shown in Figure P7.1,

where

$$G(s) = \frac{210(s+4)(s+6)(s+11)(s+13)}{s^3(s+7)(s+14)(s+19)}$$

Find the steady-state error in position. [Section: 7.3]

7. The steady-state error in velocity of a system is defined to be

WileyPLUS
WPCS
 Control Solutions

$$\left(\frac{dr}{dt} - \frac{dc}{dt} \right) \Big|_{t \rightarrow \infty}$$

where r is the system input, and c is the system output. Find the steady-state error in velocity for an input of $t^3u(t)$ to a unity feedback system with a forward transfer function of [Section: 7.2]

$$G(s) = \frac{100(s+1)(s+2)}{s^2(s+3)(s+10)}$$

8. What is the steady-state error for a step input of 15 units applied to the unity feedback system of Figure P7.1, where [Section: 7.3]

$$G(s) = \frac{1020(s+13)(s+26)(s+33)}{(s+65)(s+75)(s+91)}$$

9. A system has $K_p = 4$. What steady-state error can be expected for inputs of $70u(t)$ and $70tu(t)$? [Section 7.3]

10. For the unity feedback system shown in Figure P7.1, where [Section: 7.3]

$$G(s) = \frac{5000}{s(s+75)}$$

- What is the expected percent overshoot for a unit step input?
 - What is the settling time for a unit step input?
 - What is the steady-state error for an input of $5u(t)$?
 - What is the steady-state error for an input of $5tu(t)$?
- c. What is the steady-state error for an input of $5t^2u(t)$?

11. Given the unity feedback system shown in Figure P7.1, where

$$G(s) = \frac{100500(s+5)(s+14)(s+23)}{s(s+27)(s+\alpha)(s+33)}$$

find the value of α to yield a $K_v = 25000$. [Section: 7.4]

12. For the unity feedback system of Figure P7.1, where

$$G(s) = \frac{K(s+2)(s+4)(s+6)}{s^2(s+5)(s+7)}$$

find the value of K to yield a static error constant of 10,000. [Section: 7.4]

WileyPLUS
WPCS
 Control Solutions

13. For the system shown in Figure P7.4, [Section: 7.3]
- Find K_p , K_v , and K_a .
 - Find the steady-state error for an input of $50u(t)$, $50tu(t)$, and $50t^2u(t)$.
 - State the system type.

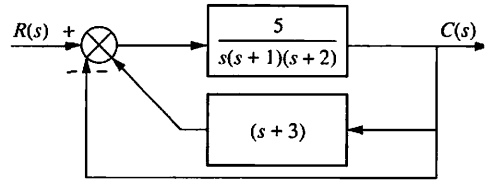

FIGURE P7.4

14. A Type 3 unity feedback system has $r(t) = 10t^3$ applied to its input. Find the steady-state position error for this input if the forward transfer function is [Section: 7.3]

$$G(s) = \frac{1030(s^2 + 8s + 23)(s^2 + 21s + 1.3)}{s^3(s+6)(s+13)}$$

15. Find the system type for the system of Figure P7.5. [Section: 7.3]

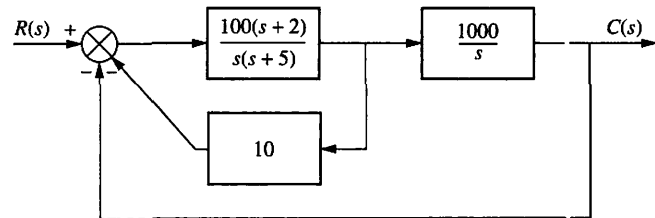

FIGURE P7.5

16. What are the restrictions on the feedforward transfer function $G_2(s)$ in the system of Figure P7.6 to obtain zero steady-state error for step inputs if: [Section: 7.3]

- $G_1(s)$ is a Type 0 transfer function;
- $G_1(s)$ is a Type 1 transfer function;
- $G_1(s)$ is a Type 2 transfer function?

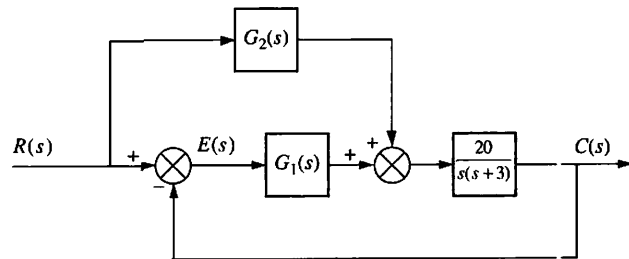

FIGURE P7.6

17. The steady-state error is defined to be the difference in position between input and output as time approaches infinity. Let us define a steady-state velocity error, which is the difference in velocity between input and output. Derive an expression for the error in velocity, $\dot{e}(\infty) = \dot{r}(\infty) - \dot{c}(\infty)$, and complete Table P7.1 for the error in velocity. [Sections: 7.2, 7.3]

TABLE P7.1

		Type		
		0	1	2
Input	Step			
	Ramp			
	Parabola			

18. For the system shown in Figure P7.7, [Section: 7.4]

WileyPLUS
WPCS
 Control Solutions

- What value of K will yield a steady-state error in position of 0.01 for an input of $(1/10)t$?
- What is the K_v for the value of K found in Part a?
- What is the minimum possible steady-state position error for the input given in Part a?

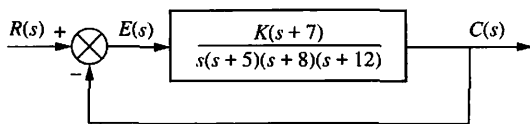

FIGURE P7.7

19. Given the unity feedback system of Figure P7.1, where

$$G(s) = \frac{K(s+a)}{s(s+2)(s+13)}$$

find the value of Ka so that a ramp input of slope 40 will yield an error of 0.006 in the steady state when compared to the output. [Section: 7.4]

20. Given the system of Figure P7.8, design the value of K so that for an input of $100tu(t)$, there will be a 0.01 error in the steady state. [Section: 7.4]

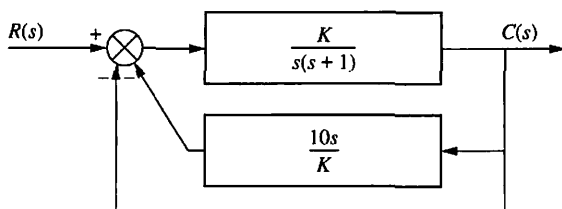

FIGURE P7.8

21. Find the value of K for the unity feedback system shown in Figure P7.1, where

$$G(s) = \frac{K(s+3)}{s^2(s+7)}$$

if the input is $10t^2u(t)$, and the desired steady-state error is 0.061 for this input. [Section: 7.4]

22. The unity feedback system of Figure P7.1, where

$$G(s) = \frac{K(s^2 + 3s + 30)}{s^n(s+5)}$$

WileyPLUS
WPCS
 Control Solutions

is to have 1/6000 error between an input of $10tu(t)$ and the output in the steady state. [Section: 7.4]

- Find K and n to meet the specification.
 - What are K_p , K_v , and K_a ?
23. For the unity feedback system of Figure P7.1, where [Section: 7.3]

$$G(s) = \frac{K(s^2 + 6s + 6)}{(s+5)^2(s+3)}$$

- Find the system type.
 - What error can be expected for an input of $12u(t)$?
 - What error can be expected for an input of $12tu(t)$?
24. For the unity feedback system of Figure P7.1, where

$$G(s) = \frac{K(s+13)(s+19)}{s(s+6)(s+9)(s+22)}$$

find the value of K to yield a steady-state error of 0.4 for a ramp input of $27tu(t)$. [Section: 7.4]

25. Given the unity feedback system of Figure P7.1, where

$$G(s) = \frac{K(s+6)}{(s+2)(s^2+10s+29)}$$

find the value of K to yield a steady-state error of 8%. [Section: 7.4]

26. For the unity feedback system of Figure P7.1, where

$$G(s) = \frac{K}{s(s+4)(s+8)(s+10)}$$

find the minimum possible steady-state position error if a unit ramp is applied. What places the constraint upon the error?

27. The unity feedback system of Figure P7.1, where

$$G(s) = \frac{K(s + \alpha)}{(s + \beta)^2}$$

is to be designed to meet the following specifications: steady-state error for a unit step input = 0.1; damping ratio = 0.5; natural frequency = $\sqrt{10}$. Find K , α , and β . [Section: 7.4]

28. A second-order, unity feedback system is to follow a ramp input with the following specifications: the steady-state output position shall differ from the input position by 0.01 of the input velocity; the natural frequency of the closed-loop system shall be 10 rad/s. Find the following:
- The system type
 - The exact expression for the forward-path transfer function
 - The closed-loop system's damping ratio
29. The unity feedback system of Figure P7.1, where

$$G(s) = \frac{K(s + \alpha)}{s(s + \beta)}$$

is to be designed to meet the following requirements: The steady-state position error for a unit ramp input equals 1/10; the closed-loop poles will be located at $-1 \pm j1$. Find K , α , and β in order to meet the specifications. [Section: 7.4]

30. Given the unity feedback control system of Figure P7.1, where

$$G(s) = \frac{K}{s^n(s + a)}$$

find the values of n , K , and a in order to meet specifications of 12% overshoot and $K_v = 110$. [Section: 7.4]

31. Given the unity feedback control system of Figure P7.1, where

$$G(s) = \frac{K}{s(s + a)}$$

find the following: [Section: 7.4]

- K and a to yield $K_v = 1000$ and a 20% overshoot
 - K and a to yield a 1% error in the steady state and a 10% overshoot
32. Given the system in Figure P7.9, find the following: [Section: 7.3]

- The closed-loop transfer function
- The system type
- The steady-state error for an input of $5u(t)$
- The steady-state error for an input of $5tu(t)$
- Discuss the validity of your answers to Parts c and d.

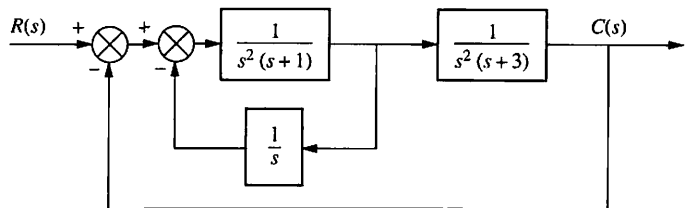

FIGURE P7.9

33. Repeat Problem 32 for the system shown in Figure P7.10. [Section: 7.3]

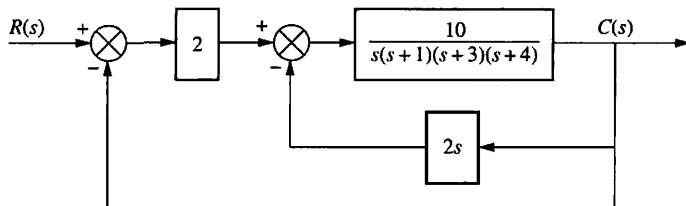

FIGURE P7.10

34. For the system shown in Figure P7.11, use MATLAB to find the following: [Section: 7.3]

MATLAB
ML

- The system type
- K_p , K_v , and K_a
- The steady-state error for inputs of $100u(t)$, $100tu(t)$, and $100t^2u(t)$

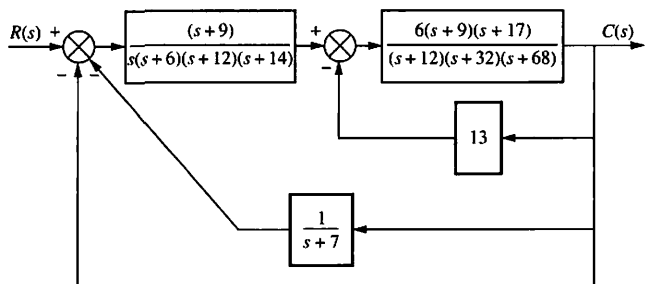

FIGURE P7.11

35. The system of Figure P7.12 is to have the following specifications: $K_v = 10$; $\zeta = 0.5$. Find the values of K_1 and K_f required for the specifications of the system to be met. [Section: 7.4]

WileyPLUS
WPCS
Control Solutions

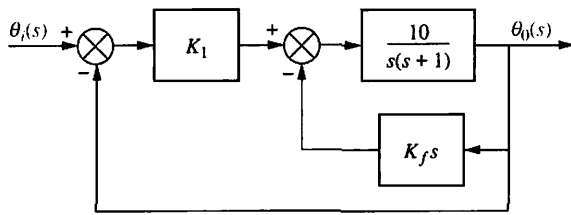

FIGURE P7.12

36. The transfer function from elevator deflection to altitude change in a Tower Trainer 60 Unmanned Aerial Vehicle is

$$P(s) = \frac{h(s)}{\delta(s)_e} = \frac{-34.16s^3 - 144.4s^2 + 7047s + 557.2}{s^5 + 13.18s^4 + 95.93s^3 + 14.61s^2 + 31.94s}$$

An autopilot is built around the aircraft as shown in Figure P7.13, with $F(s) = H(s) = 1$ and

$$G(s) = \frac{0.00842(s + 7.895)(s^2 + 0.108s + 0.3393)}{(s + 0.07895)(s^2 + 4s + 8)}$$

(Barkana, 2005). The steady-state error for a ramp input in this system is $e_{ss} = 25$. Find the slope of the ramp input.

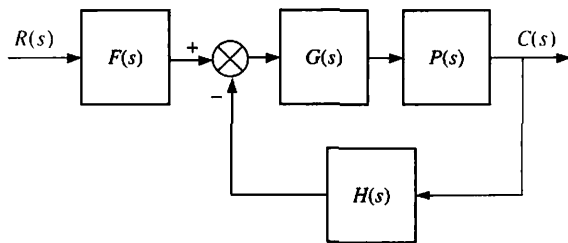

FIGURE P7.13

37. A block diagram representing the Ktesibios' water clock discussed in Section 1.2 is shown in Chapter 5, Problem 58, Figure P5.38(b) (Lepschy, 1992).
- Find the system's type.
 - For $h_r(t) = u(t)$, find the steady-state value of $e(t) = h_r(t) - h_f(t)$.
38. Find the total steady-state error due to a unit step input and a unit step disturbance in the system of Figure P7.14. [Section: 7.5]

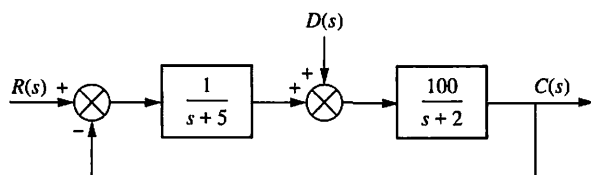

FIGURE P7.14

39. Design the values of K_1 and K_2 in the system of Figure P7.15 to meet the following specifications: Steady-state error component due to a unit step disturbance is -0.000012 ; steady-state error component due to a unit ramp input is 0.003 . [Section: 7.5]

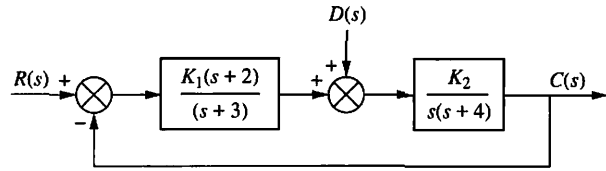

FIGURE P7.15

40. In Figure P7.16, let $G(s) = 5$ and $P(s) = \frac{7}{s+2}$.
- Calculate the steady-state error due to a command input $R(s) = \frac{3}{s}$ with $D(s) = 0$.
 - Verify the result of Part a using Simulink. Simulink
SL
 - Calculate the steady-state error due to a disturbance input $D(s) = -\frac{1}{s}$ with $R(s) = 0$.
 - Verify the result of Part c using Simulink. Simulink
SL
 - Calculate the total steady-state error due to a command input $R(s) = \frac{3}{s}$ and a disturbance $D(s) = -\frac{1}{s}$ applied simultaneously.
 - Verify the result of Part e using Simulink. Simulink
SL

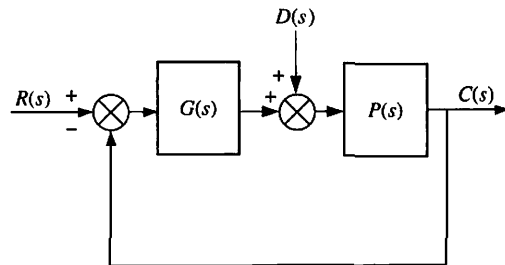

FIGURE P7.16

41. Derive Eq. (7.72) in the text, the final value of the actuating signal for nonunity feedback systems. [Section: 7.6]
42. For each of the systems shown in Figure P7.17, find the following: [Section: 7.6]
- The system type
 - The appropriate static error constant
 - The input waveform to yield a constant error

- d. The steady-state error for a unit input of the waveform found in Part c
- e. The steady-state value of the actuating signal

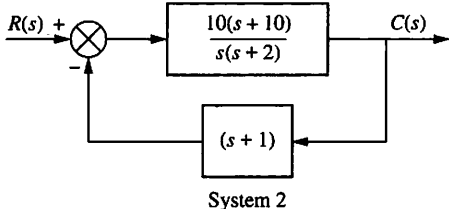
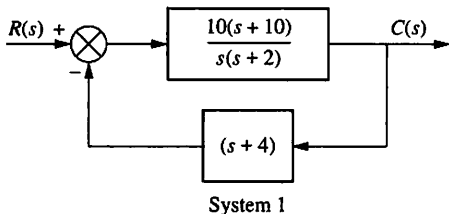

FIGURE P7.17 Closed-loop systems with nonunity feedback

43. For each of the systems shown in Figure P7.18, find the appropriate static error constant as well as the steady-state error, $r(\infty) - c(\infty)$, for unit step, ramp, and parabolic inputs. [Section: 7.6]

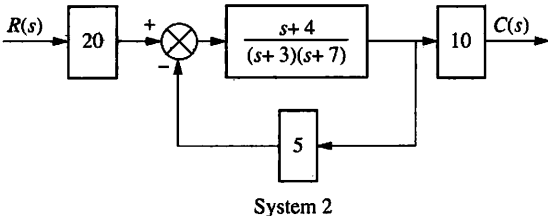
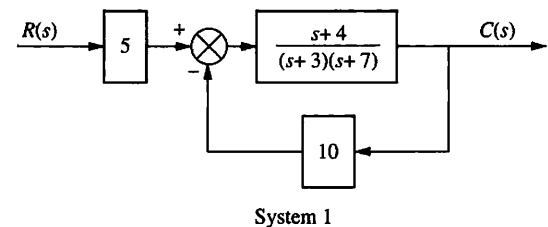

FIGURE P7.18

44. Given the system shown in Figure P7.19, find the following: [Section: 7.6]
- a. The system type
 - b. The value of K to yield 0.1% error in the steady state

WileyPLUS
WPCS
Control Solutions

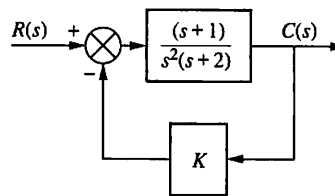

FIGURE P7.19

45. For the system shown in Figure P7.20, [Section: 7.6]
- a. What is the system type?
 - b. What is the appropriate static error constant?
 - c. What is the value of the appropriate static error constant?
 - d. What is the steady-state error for a unit step input?

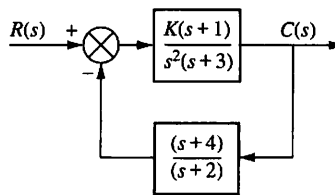

FIGURE P7.20

46. For the system shown in Figure P7.21, use MATLAB to find the following for $K = 10$, and $K = 10^6$: [Section: 7.6]
- a. The system type
 - b. K_p , K_v , and K_a
 - c. The steady-state error for inputs of $30u(t)$, $30tu(t)$, and $30t^2u(t)$

MATLAB
ML

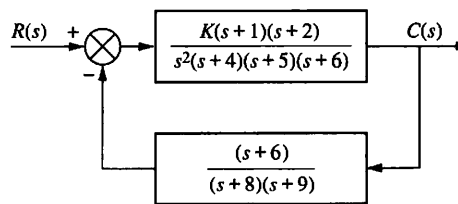

FIGURE P7.21

47. A dynamic voltage restorer (DVR) is a device that is connected in series to a power supply. It continuously monitors the voltage delivered to the load, and compensates voltage sags by applying the necessary extra voltage to maintain the load voltage constant.

In the model shown in Figure P7.22, u_r represents the desired reference voltage, u_o is the output

voltage, and Z_L is the load impedance. All other parameters are internal to the DVR (*Lam, 2004*).

- Assuming $Z_L = \frac{1}{sC_L}$, and $\beta \neq 1$, find the system's type.
- Find the steady-state error to a unit step input as a function of β .

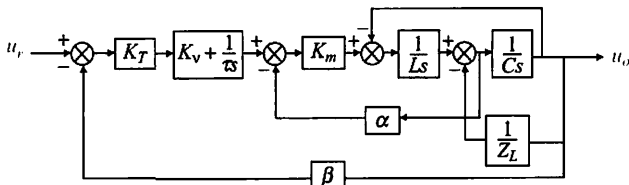

FIGURE P7.22 DVR Model

- Derive Eq. (7.69) in the text. [Section: 7.6]
- Given the system shown in Figure P7.23, do the following: [Section: 7.6]
 - Derive the expression for the error, $E(s) = R(s) - C(s)$, in terms of $R(s)$ and $D(s)$.
 - Derive the steady-state error, $e(\infty)$, if $R(s)$ and $D(s)$ are unit step functions.
 - Determine the attributes of $G_1(s)$, $G_2(s)$, and $H(s)$ necessary for the steady-state error to become zero.

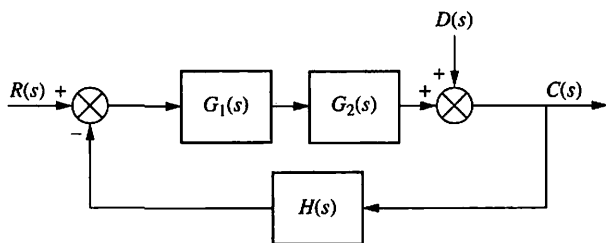

FIGURE P7.23 System with input and disturbance

- Given the system shown in Figure P7.24, find the sensitivity of the steady-state error to parameter a . Assume a step input. Plot the sensitivity as a function of parameter a . [Section: 7.7]

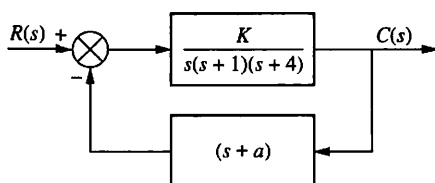

FIGURE P7.24

- Show that the sensitivity to plant changes in the system of Figure P7.13 is

$$S_{T:P} = \frac{P \delta T}{T \delta P} = \frac{1}{1 + L(s)}$$
 where $L(s) = G(s)P(s)H(s)$ and

$$T(s) = \frac{C(s)}{R(s)} = \frac{F(s)L(s)}{1 + R(s)}$$
 - Show that $S_{T:P}(s) + \frac{T(s)}{F(s)} = 1$ for all values of s .

- In Figure P7.13, $P(s) = \frac{2}{s}$,

$$T(s) = \frac{C(s)}{R(s)} = \frac{14K}{(s+1)(s+2)(s^2+5s+14)}$$

and

$$S_{T:P} = \frac{P \delta T}{T \delta P} = \frac{s^2 + 5s}{s^2 + 5s + 14}$$

- Find $F(s)$ and $G(s)$.
 - Find the value of K that will result in zero steady-state error for a unit step input.
- For the system shown in Figure P7.25, find the sensitivity of the steady-state error for changes in K_1 and in K_2 , when $K_1 = 100$ and $K_2 = 0.1$. Assume step inputs for both the input and the disturbance. [Section: 7.7]

WileyPLUS
WPCS
 Control Solutions

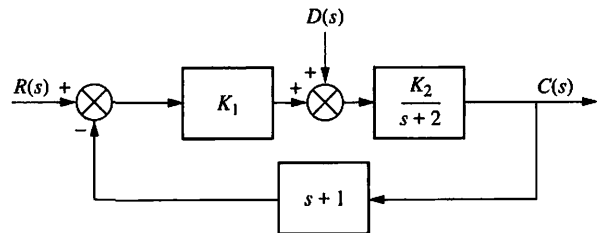

FIGURE P7.25 System with input and disturbance

- Given the block diagram of the active suspension system shown in Figure P5.43 (*Lin, 1997*):
 - Find the transfer function from a road disturbance r to the error signal e .
 - Use the transfer function in Part a to find the steady-state value of e for a unit step road disturbance.
 - Use the transfer function in Part a to find the steady-state value of e for a unit ramp road disturbance.
 - From your results in Parts b and c, what is the system's type for e ?
- For each of the following closed-loop systems, find the steady-state error for unit step and unit ramp

inputs. Use both the final value theorem and input substitution methods. [Section: 7.8]

a. $\dot{\mathbf{x}} = \begin{bmatrix} -5 & -4 & -2 \\ -3 & -10 & 0 \\ -1 & 1 & -5 \end{bmatrix} \mathbf{x} + \begin{bmatrix} 1 \\ 1 \\ 0 \end{bmatrix} r; y = [-1 \ 2 \ 1] \mathbf{x}$

b. $\dot{\mathbf{x}} = \begin{bmatrix} 0 & 1 & 0 \\ -5 & -9 & 7 \\ -1 & 0 & 0 \end{bmatrix} \mathbf{x} + \begin{bmatrix} 0 \\ 0 \\ 1 \end{bmatrix} r; y = [1 \ 0 \ 0] \mathbf{x}$

c. $\dot{\mathbf{x}} = \begin{bmatrix} -9 & -5 & -1 \\ 1 & 0 & -2 \\ -3 & -2 & -5 \end{bmatrix} \mathbf{x} + \begin{bmatrix} 2 \\ 3 \\ 5 \end{bmatrix} r; y = [1 \ -2 \ 4] \mathbf{x}$

56. An automobile guidance system yields an actual output distance, $X(s)$, for a desired input distance, $X_c(s)$, as shown in Figure P7.26(a). Any difference, $X_e(s)$, between the commanded distance and the actual distance is converted into a velocity command, $V_c(s)$, by the controller and applied to the vehicle accelerator. The vehicle responds to the velocity command with a velocity, $V(s)$, and a displacement, $X(s)$, is realized. The velocity control, $G_2(s)$, is itself a closed-loop system, as shown in Figure P7.26(b). Here the difference, $V_e(s)$, between the commanded velocity, $V_c(s)$, and the actual vehicle velocity, $V(s)$, drives a motor that displaces the automobile's accelerator by $Y_c(s)$ (Stefani, 1978). Find the steady-state error for the velocity control loop if the motor and amplifier transfer function $G_3(s) = K/[s(s+1)]$. Assume $G_4(s)$ to be a first-order system, where a maximum possible 1-foot displacement of the accelerator linkage yields a steady-state velocity of 100 miles/hour, with the automobile reaching 60 miles/hour in 10 seconds.

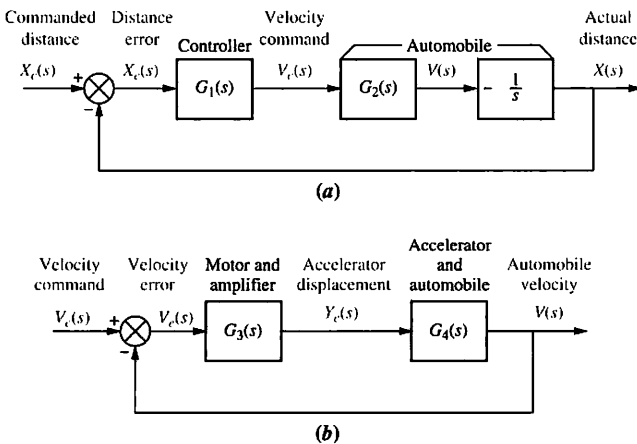

FIGURE P7.26 Automobile guidance system: a. displacement control system; b. velocity control loop

57. A simplified block diagram of a meter used to measure oxygen concentration is shown in Figure P7.27. The meter uses the paramagnetic properties of a stream of

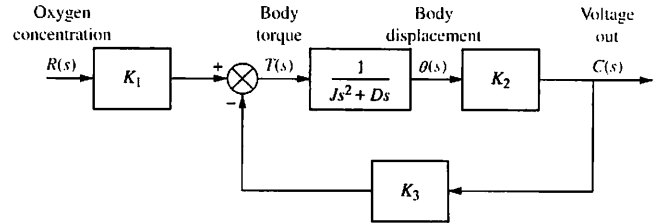

FIGURE P7.27 Block diagram of a paramagnetic oxygen analyzer

oxygen. A small body is placed in a stream of oxygen whose concentration is $R(s)$, and it is subjected to a magnetic field. The torque on the body, $K_1R(s)$, due to the magnetic field is a function of the concentration of the oxygen. The displacement of the body, $\theta(s)$, is detected, and a voltage, $C(s)$, is developed proportional to the displacement. This voltage is used to develop an electrostatic field that places a torque, $K_3C(s)$, on the body opposite to that developed by the magnetic field. When the body comes to rest, the output voltage represents the strength of the magnetic torque, which in turn is related to the concentration of the oxygen (Chesmond, 1982). Find the steady-state error between the output voltage, representing oxygen concentration, and the input oxygen concentration. How would you reduce the error to zero?

58. A space station, shown in Figure P7.28(a), will keep its solar arrays facing the Sun. If we assume that the simplified block diagram of Figure P7.28(b) represents the solar tracking control system that will be used to rotate the array via rotary joints called *solar alpha rotary joints* (Figure P7.28(c)). Find (Kumar, 1992)

- a. The steady-state error for step commands
- b. The steady-state error for ramp commands
- c. The steady-state error for parabolic commands
- d. The range of K_c/J to make the system stable

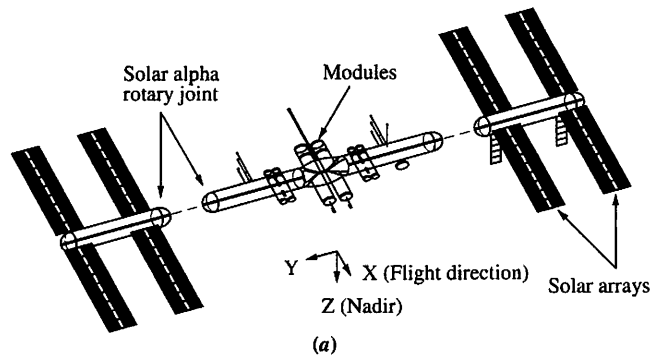
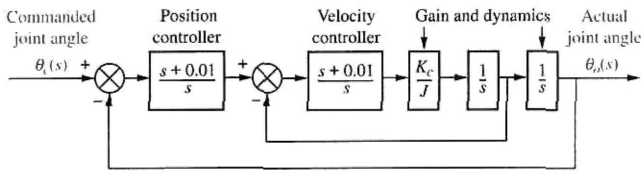
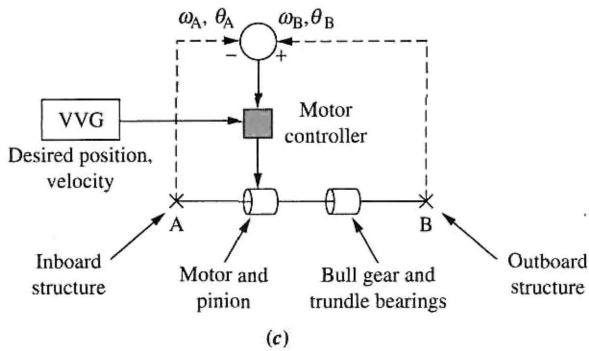
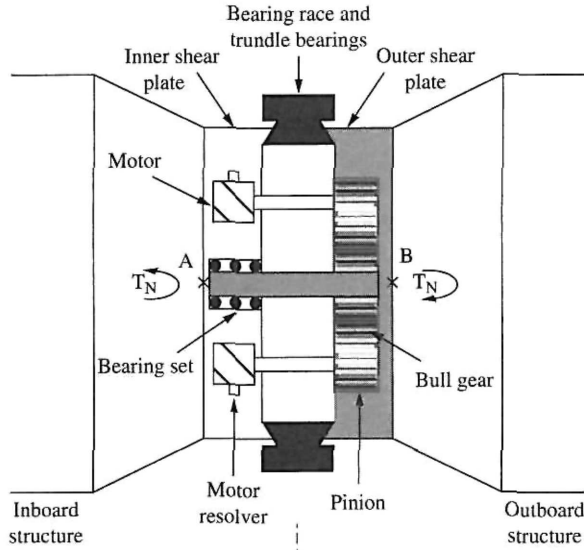

FIGURE P7.28 A space station: a. configuration (© 1992 AIAA); (figure continues)



(b)



(c)

FIGURE P7.28 (Continued) b. simplified block diagram; c. alpha joint drive train and control system (© 1992 AIAA)

59. A simplified model of the steering of a four-wheel drive vehicle is shown in Figure P7.29.

In this block diagram, the output r is the vehicle's yaw rate, while δ_f and δ_r are the steering angles of the front and rear tires respectively. In this model,

$$r^*(s) = \frac{s}{\frac{s}{300} + 0.8} + 0.8, \quad G_f(s) = \frac{h_1 s + h_2}{s^2 + a_1 s + a_2},$$

$$G_r(s) = \frac{h_3 s + b_1}{s^2 + a_1 s + a_2}$$

and $K(s)$ is a controller to be designed. (Yin, 2007).

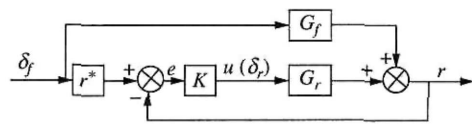

FIGURE P7.29 Steering model for a four-wheel drive vehicle (© 2007 IEEE)

- Assuming a step input for δ_f , find the minimum system type of the controller $K(s)$ necessary so that in steady-state the error as defined by the signal e in Figure P7.29 is zero if at all possible.
- Assuming a step input for δ_f , find the system type of the controller $K(s)$ necessary so that in steady state the error as defined by $\delta_f(\infty) - r(\infty)$ is zero if at all possible.

DESIGN PROBLEMS

60. The following specification applies to a position control: $K_v = 10$. On hand is an amplifier with a variable gain, K_2 , with which to drive a motor. Two one-turn pots to convert shaft position into voltage are also available, where $\pm 3\pi$ volts are placed across the pots. A motor is available whose transfer function is

$$\frac{\theta_m(s)}{E_a(s)} = \frac{K}{s(s + \alpha)}$$

where $\theta_m(s)$ is the motor armature position and $E_a(s)$ is the armature voltage. The components are interconnected as shown in Figure P7.30.

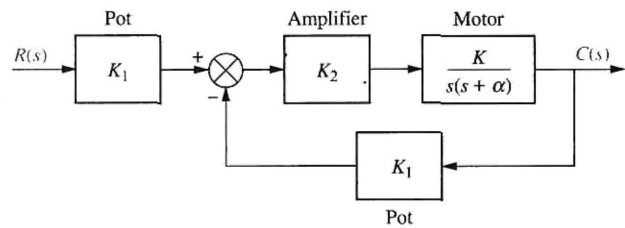

FIGURE P7.30 Position control system

The transfer function of the motor is found experimentally as follows. The motor and load are driven separately by applying a large, short square wave (a unit impulse) to the armature. An oscillograph of the response shows that the motor reached 63% of its final output value 0.5 second after application of the impulse. Furthermore, with 10 volts dc applied to the armature, the constant output speed was 100 rad/s. Draw the completed block diagram of the system, specifying the transfer function of each component of the block diagram.

61. A boat is circling a ship that is using a tracking radar. The speed of the boat is 20 knots, and it is circling

the ship at a distance of 1 nautical mile, as shown in Figure P7.31(a). A simplified model of the tracking system is shown in Figure P7.31(b). Find the value of K so that the boat is kept in the center of the radar beam with no more than 0.1 degree error.

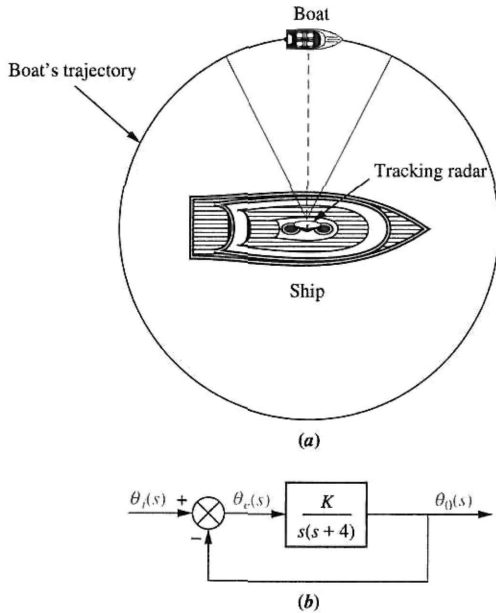

FIGURE P7.31 Boat tracked by ship's radar: a. physical arrangement; b. block diagram of tracking system

62. Figure P7.32 shows a simplified block diagram of a pilot in a loop to control the roll attitude of an Army UH-60A Black Hawk twin-engine helicopter with a single main rotor (Hess, 1993).

- Find the system type.
- The pilot's response determines K_1 . Find the value of K_1 if an appropriate static error constant value of 700 is required.

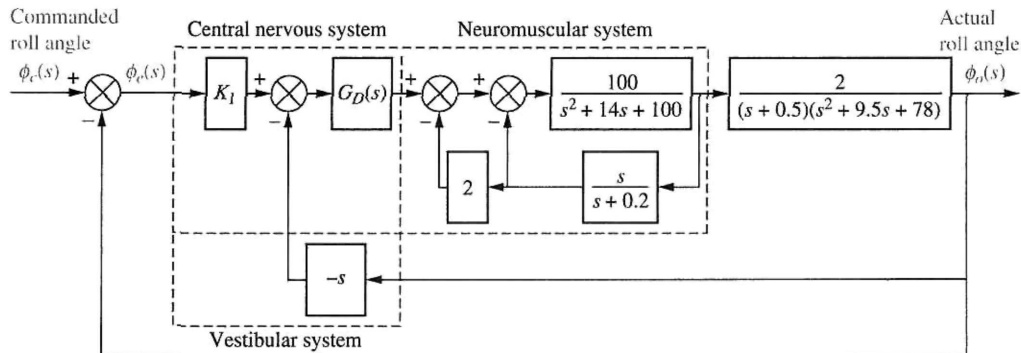

FIGURE P7.32 Simplified block diagram of a pilot in a loop (© 1992 AIAA)

- Would a pilot whose K_1 is the value found in Part b be hired to fly the helicopter?

Note: In the block diagram $G_D(s)$ is a delay of about 0.154 second and can be represented by a Pade approximation of $G_D(s) = -(s - 13)/(s + 13)$.

63. Motion control, which includes position or force control, is used in robotics and machining. Force control requires the designer to consider two phases: contact and non-contact motions. Figure P7.33(a) is a diagram of a mechanical system for force control under contact motion. A force command, $F_{cmd}(s)$, is the input to the system, while the output, $F(s)$, is the controlled contact force.

In the figure a motor is used as the force actuator. The force output from the actuator is applied to the

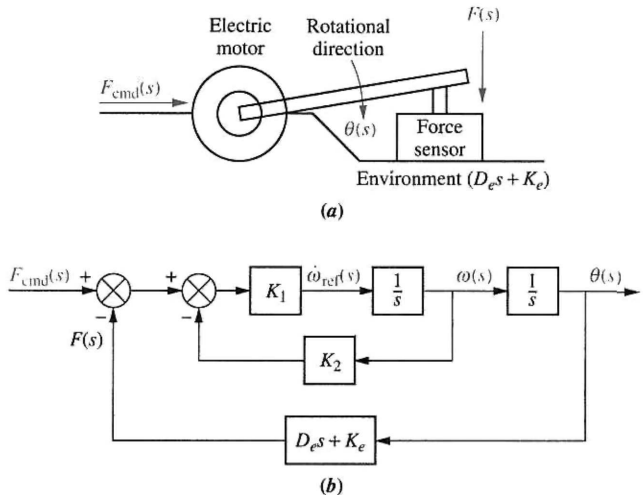

FIGURE P7.33 a. Force control mechanical loop under contact motion (© 1996 IEEE); b. block diagram (© 1996 IEEE)

WileyPLUS
WPCS

Control Solutions

object through a force sensor. A block diagram representation of the system is shown in Figure P7.33(b). K_2 is velocity feedback used to improve the transient response. The loop is actually implemented by an electrical loop (not shown) that controls the armature current of the motor to yield the desired torque at the output. Recall that $T_m = K_t i_a$ (Ohmishi, 1996). Find an expression for the range of K_2 to keep the steady-state force error below 10% for ramp inputs of commanded force.

64. Problem 50 in Chapter 4 describes an open-loop swivel controller and plant for an industrial robot. The transfer function for the controller and plant is

$$G_e(s) = \frac{\omega_o(s)}{V_i(s)} = \frac{K}{(s+10)(s^2+4s+10)}$$

where $\omega_o(s)$ is the Laplace transform of the robot's angular swivel velocity and $V_i(s)$ is the input voltage to the controller. Assume $G_e(s)$ is the forward transfer function of a velocity control loop with an input transducer and sensor, each represented by a constant gain of 3 (Schneider, 1992).

- Find the value of gain, K , to minimize the steady-state error between the input commanded angular swivel velocity and the output actual angular swivel velocity.
 - What is the steady-state error for the value of K found in Part a?
 - For what kind of input does the design in Part a apply?
65. Packet information flow in a router working under TCP/IP can be modeled using the linearized transfer function

$$P(s) = \frac{Q(s)}{f(s)} = \frac{\frac{C^2}{2N} e^{-sR}}{\left(s + \frac{2N}{R^2 C}\right) \left(s + \frac{1}{R}\right)}$$

where

C = link capacity (packets/second).

N = load factor (number of TCP sessions)

Q = expected queue length

R = round trip time (second)

p = probability of a packet drop

The objective of an active queue management (AQM) algorithm is to automatically choose a packet-drop probability, p , so that the queue length is maintained at a desired level. This system can be represented by the block diagram of Figure P7.13 with the plant model in the $P(s)$ block, the AQM algorithm in the $G(s)$ block, and $F(s) = H(s) = 1$.

Several AQM algorithms are available, but one that has received special attention in the literature is the random early detection (RED) algorithm. This algorithm can be approximated with $G(s) = \frac{LK}{s+K}$, where L and K are constants (Hollot, 2001). Find the value of L required to obtain a 10% steady-state error for a unit step input when $C = 3750$ packets/s, $N = 50$ TCP sessions, $R = 0.1$ s, and $K = 0.005$.

66. In Figure P7.16, the plant, $P(s) = \frac{48,500}{s^2 + 2.89s}$, represents the dynamics of a robotic manipulator joint. The system's output, $C(s)$, is the joint's angular position (Low, 2005). The system is controlled in a closed-loop configuration as shown with $G(s) = K_P + \frac{K_I}{s}$, a proportional-plus-integral (PI) controller to be discussed in Chapter 9. $R(s)$ is the joint's desired angular position. $D(s)$ is an external disturbance, possibly caused by improper dynamics modeling, Coulomb friction, or other external forces acting on the joint.
- Find the system's type.
 - Show that for a step disturbance input, $e_{ss} = 0$ when $K_I \neq 0$.
 - Find the value of K_I that will result in $e_{ss} = 5\%$ for a parabolic input.
 - Using the value of K_I found in Part c, find the range of K_P for closed-loop stability.

PROGRESSIVE ANALYSIS AND DESIGN PROBLEMS

67. **High-speed rail pantograph.** Problem 21 in Chapter 1 discusses the active control of a pantograph mechanism for high-speed rail systems. In Problem 79(a), Chapter 5, you found the block diagram for the active pantograph control system. Use your solution for Problem 79(a) in Chapter 5 to perform steady-state error analysis and design as follows (O'Connor, 1997):
- Find the system type.
 - Find the value of controller gain, K , that minimizes the steady-state force error.
 - What is the minimum steady-state force error?
68. **Control of HIV/AIDS.** Consider the HIV infection model of Problem 68 in Chapter 6 and its block diagram in Figure P6.20 (Craig, 2004).
- Find the system's type if $G(s)$ is a constant.
 - It was shown in Problem 68, Chapter 6, that when $G(s) = K$ the system will be stable when $K < 2.04 \times 10^{-4}$. What value of K will result in a unit step input steady-state error of 10%?

- c. It is suggested that to reduce the steady-state error the system's type should be augmented by making $G(s) = \frac{K}{s}$. Is this a wise choice? What is the resulting stability range for K ?

69. **Hybrid vehicle.** Figure P7.34 shows the block diagram of the speed control of an HEV taken from Figure P5.54, and rearranged as a unity feedback system (Preitl, 2007). Here the system output is, $C(s) = K_{SS} V(s)$, the output voltage of the speed sensor/transducer.

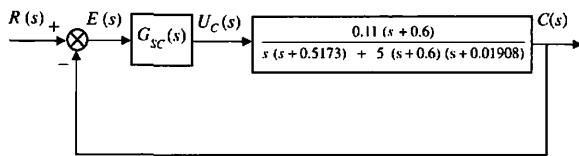

FIGURE P7.34

- a. Assume the speed controller is given as $G_{sc}(s) = K_{P_{sc}}$. Find the gain, $K_{P_{sc}}$, that yields a steady-state error, $e_{step}(\infty) = 1\%$.
- b. Now assume that in order to reduce the steady-state error for step inputs, integration is added to the controller yielding $G_{sc}(s) = K_{P_{sc}} + (K_{I_{sc}}/s) = 100 + (K_{I_{sc}}/s)$. Find the value of the integral gain, $K_{I_{sc}}$, that results in a steady-state error, $e_{ramp}(\infty) = 2.5\%$.
- c. In Parts a and b, the HEV was assumed to be driven on level ground. Consider the case when, after reaching a steady-state speed with a controller

given by $G_{sc}(s) = 100 + \frac{40}{s}$, the car starts climbing up a hill with a gradient angle, $\alpha = 5^\circ$. For small angles $\sin \alpha = \alpha$ (in radians) and, hence, when reflected to the motor shaft the climbing torque is:

$$T_{st} = \frac{F_{st}r}{i_{tot}} = \frac{mgr}{i_{tot}} \sin \alpha = \frac{mgr\alpha}{i_{tot}} = \frac{1590 \times 9.8 \times 0.3 \times 5}{4.875 \times 57.3} = 83.7 \text{ Nm.}$$

The block diagram in Figure P7.35 represents the control system of the HEV rearranged for Part c.

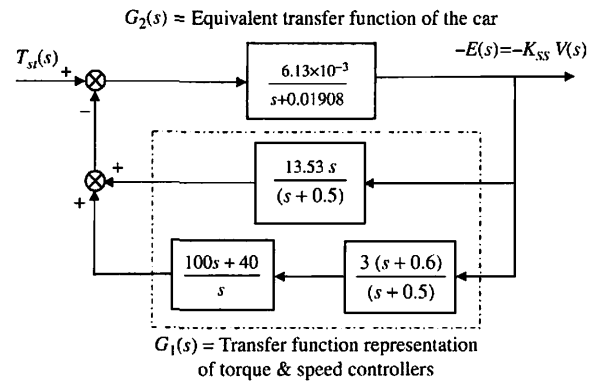

FIGURE P7.35

In this diagram, the input is $T_{st}(t) = 83.7 u(t)$, corresponding to $\alpha = 5^\circ$, and the output is the negative error, $-e(t) = -c(t) = -K_{SS} v(t)$, proportional to the change in car speed, $v(t)$. Find the steady-state error $e(\infty)$ due to a step change in the disturbance; e.g., the climbing torque, $T_{st}(t) = 83.7 u(t)$.

Cyber Exploration Laboratory

Experiment 7.1

Objective To verify the effect of input waveform, loop gain, and system type upon steady-state errors.

Minimum Required Software Packages MATLAB, Simulink, and the Control System Toolbox

Prelab

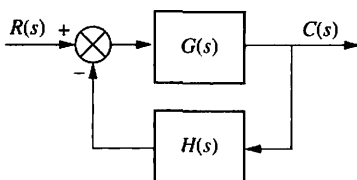

FIGURE P7.36

1. What system types will yield zero steady-state error for step inputs?
2. What system types will yield zero steady-state error for ramp inputs?
3. What system types will yield infinite steady-state error for ramp inputs?
4. What system types will yield zero steady-state error for parabolic inputs?
5. What system types will yield infinite steady-state error for parabolic inputs?
6. For the negative feedback system of Figure P7.36, where $G(s) = \frac{K(s+6)}{(s+4)(s+7)(s+9)(s+12)}$ and $H(s) = 1$, calculate the steady-state error in terms of K for the following inputs: $5u(t)$, $5tu(t)$, and $5t^2u(t)$.

7. Repeat Prelab 6 for $G(s) = \frac{K(s+6)(s+8)}{s(s+4)(s+7)(s+9)(s+12)}$ and $H(s) = 1$.

8. Repeat Prelab 6 for $G(s) = \frac{K(s+1)(s+6)(s+8)}{s^2(s+4)(s+7)(s+9)(s+12)}$ and $H(s) = 1$.

Lab

- Using Simulink, set up the negative feedback system of Prelab 6. Plot on one graph the error signal of the system for an input of $5u(t)$ and $K = 50, 500, 1000,$ and 5000 . Repeat for inputs of $5tu(t)$ and $5t^2u(t)$.
- Using Simulink, set up the negative feedback system of Prelab 7. Plot on one graph the error signal of the system for an input of $5u(t)$ and $K = 50, 500, 1000,$ and 5000 . Repeat for inputs of $5tu(t)$ and $5t^2u(t)$.
- Using Simulink, set up the negative feedback system of Prelab 8. Plot on one graph the error signal of the system for an input of $5u(t)$ and $K = 200, 400, 800,$ and 1000 . Repeat for inputs of $5tu(t)$ and $5t^2u(t)$.

Postlab

- Use your plots from Lab 1 and compare the expected steady-state errors to those calculated in the Prelab. Explain the reasons for any discrepancies.
- Use your plots from Lab 2 and compare the expected steady-state errors to those calculated in the Prelab. Explain the reasons for any discrepancies.
- Use your plots from Lab 3 and compare the expected steady-state errors to those calculated in the Prelab. Explain the reasons for any discrepancies.

Experiment 7.2

Objective To use the LabVIEW Control Design and Simulation Module for analysis of steady-state performance for step and ramp inputs.

Minimum Required Software Package LabVIEW with the Control Design and Simulation Module

Prelab You are given the model of a single joint of a robotic manipulator shown in Figure P7.37 (Spong, 2005), where B is the coefficient of viscous friction, $\theta_d(s)$ is the desired angle, $\theta(s)$ is the output angle, and $D(s)$ is the disturbance. We want to track the joint angle using a PD controller, which we will study in Chapter 9.

Assume $J = B = 1$. Find the step and ramp responses of this system for the following combinations of PD gains (K_P, K_D) : (16, 7), (64, 15), and (144, 23).

Lab

- Create a LabVIEW VI to simulate the response of this system to a step and a ramp inputs, under no-disturbance conditions. Use the functions available in the **Control Design and Simulation/Control Design** palette.
- Create a LabVIEW VI using the functions available in the **Control Design and Simulation/Simulation** palette, to track an input set-point of 10 under a disturbance of $D = 40$.

Postlab Compare your results with those of the Prelab. What conclusions can you draw from the various responses of this system to different inputs and different PD parameters? What is the system type? Does the steady-state behavior corroborate the theory you learned regarding system type and the steady-state error for various inputs? Explain your answer.

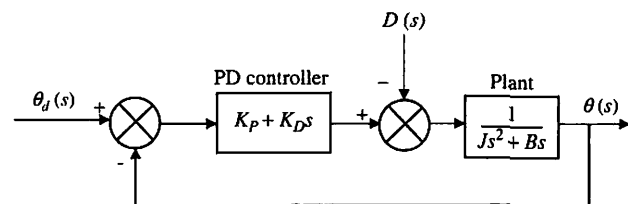

FIGURE P7.37

(Bibliography)

- Barkana, I. Classical and Simple Adaptive Control of Nonminimum Phase Autopilot Design. *Journal of Guidance, Control, and Dynamics*, vol. 28, 2005, pp. 631–638.
- Chesmond, C. J., *Control System Technology*. E. Arnold, London, 1982.
- Craig, I. K., Xia, X., and Venter, J. W., Introducing HIV/AIDS Education into the Electrical Engineering Curriculum at the University of Pretoria. *IEEE Transactions on Education*, vol. 47, no. 1, February 2004, pp. 65–73.
- D’Azzo, J. J., and Houpis, C. H., *Feedback Control System Analysis and Design Conventional and Modern*, 3d ed. McGraw-Hill, New York, 1988.
- Hess, R. A., Malsbury, T., and Atencio, A., Jr. Flight Simulator Fidelity Assessment in a Rotorcraft Lateral Translation Maneuver. *Journal of Guidance, Control, and Dynamics*, vol. 16, no. 1, January–February 1993, pp. 79–85.
- Hollot, C. V., Misra, V., Towsley, D., and Gong, W., A Control Theoretic Analysis of RED. *Proceedings of IEEE INFOCOM*, 2001, pp. 1510–1519.
- Hostetter, G. H., Savant, C. J., Jr., and Stefani, R. T. *Design of Feedback Control Systems*, 2d ed. Saunders College Publishing, New York, 1989.
- Isailović, J. *Videodisc and Optical Memory Systems*. Prentice Hall, Upper Saddle River, NJ, 1985.
- Kumar, R. R., Cooper, P. A., and Lim, T. W. Sensitivity of Space Station Alpha Joint Robust Controller to Structural Modal Parameter Variations. *Journal of Guidance, Control, and Dynamics*, vol. 15, no. 6, November–December 1992, pp. 1427–1433.
- Lam, C. S., Wong, M. C., and Han, Y. D. Stability Study on Dynamic Voltage Restorer (DVR). *Power Electronics Systems and Applications, 2004; Proceedings First International Conference on Power Electronics*, 2004, pp. 66–71.
- Lepschy, A. M., Mian, G. A., and Viaro, U. Feedback Control in Ancient Water and Mechanical Clocks. *IEEE Transactions on Education*, vol. 35, 1992, pp. 3–10.
- Lin, J.-S., and Kanellakopoulos, I. Nonlinear Design of Active Suspensions. *IEEE Control Systems*, vol. 17, issue 3, June 1997, pp. 45–59.
- Low, K. H., Wang, H., Liew, K. M., and Cai, Y. Modeling and Motion Control of Robotic Hand for Telemanipulation Application. *International Journal of Software Engineering and Knowledge Engineering*, vol. 15, 2005, pp. 147–152.
- O’Connor, D. N., Eppinger, S. D., Seering, W. P., and Wormly, D. N. Active Control of a High-Speed Pantograph. *Journal of Dynamic Systems, Measurements, and Control*, vol. 119, March 1997, pp. 1–4.
- Ohnishi, K., Shibata, M., and Murakami, T. Motion Control for Advanced Mechatronics. *IEEE/ASME Transactions on Mechatronics*, vol. 1, no. 1, March 1996, pp. 56–67.
- Preitl, Z., Bauer, P., and Bokor, J. A Simple Control Solution for Traction Motor Used in Hybrid Vehicles. *Fourth International Symposium on Applied Computational Intelligence and Informatics*. IEEE, 2007.
- Schneider, R. T. Pneumatic Robots Continue to Improve. *Hydraulics & Pneumatics*, October 1992, pp. 38–39.
- Spong, M., Hutchinson, S., and Vidyasagar, M. *Robot Modeling and Control*. John Wiley & Sons. Hoboken, NJ, 2006.
- Stefani, R. T. Design and Simulation of an Automobile Guidance and Control System. *Transactions, Computers in Education Division of ASEE*, January 1978, pp. 1–9.
- Yin, G., Chen, N., and Li, P. Improving Handling Stability Performance of Four-Wheel Steering Vehicle via μ -Synthesis Robust Control. *Ieee Transactions on Vehicular Technology*, vol. 56, no. 5, 2007, pp. 2432–2439.